



CERTIFICATION TEST REPORT

Report Number. : 12678282-E1V3

Applicant : Samsung Electronics Co., Ltd.
129 Samsung-Ro, Yeongtong-Gu,
Suwon-Si, Gyeonggi-Do, 16677, Korea

Model : SM-A305F/DS and SM-A305F

FCC ID : A3LSMA305F

EUT Description : GSM/WCDMA/LTE Phone with BT, DTS/UNII a/b/g/n/ac and ANT+

Test Standard(s) : FCC CFR47 PART 15 SUBPART B
FCC CFR47 PART 22 SUBPART H
FCC CFR47 PART 24 SUBPART E
FCC CFR47 PART 27 SUBPART F, H, L, and M

Date Of Issue:
FEBRUARY 13, 2019

Prepared by:
UL Verification Services Inc.
47173 Benicia Street
Fremont, CA 94538 U.S.A.
TEL: (510) 771-1000
FAX: (510) 661-0888



NVLAP Lab code: 200065-0

Revision History

<u>Rev.</u>	<u>Issue Date</u>	<u>Revisions</u>	<u>Revised By</u>
V1	2/4/2019	Initial Review	--
V2	2/7/2019	Updated Section 7.1	Steven Tran
V3	2/13/2019	Included FCC 47 CFR PART 15 SUBPART B applicable standards in Sections 1 and 2	Steven Tran

TABLE OF CONTENTS

TABLE OF CONTENTS	3
1. ATTESTATION OF TEST RESULTS	6
2. TEST METHODOLOGY	7
3. FACILITIES AND ACCREDITATION	7
4. CALIBRATION AND UNCERTAINTY	8
4.1. MEASURING INSTRUMENT CALIBRATION.....	8
4.2. SAMPLE CALCULATION.....	8
4.3. MEASUREMENT UNCERTAINTY.....	8
5. EQUIPMENT UNDER TEST	9
5.1. DESCRIPTION OF EUT.....	9
5.2. MAXIMUM OUTPUT POWER.....	9
5.3. SOFTWARE AND FIRMWARE.....	11
5.4. MAXIMUM ANTENNA GAIN.....	12
5.5. WORST-CASE CONFIGURATION AND MODE.....	13
5.6. DESCRIPTION OF TEST SETUP.....	14
6. TEST AND MEASUREMENT EQUIPMENT	17
7. RF OUTPUT POWER VERIFICATION	18
7.1. GSM.....	18
7.1.1. GSM850.....	19
7.1.2. GSM1900.....	19
7.2. WCDMA.....	20
7.2.1. WCDMA BAND5.....	24
7.2.2. WCDMA BAND2.....	25
7.3. LTE.....	26
7.3.1. LTE 5.....	28
7.3.2. LTE 41 (FCC).....	30
8. CONDUCTED TEST RESULTS	32
8.1. OCCUPIED BANDWIDTH.....	32
8.1.1. GSM.....	34
8.1.2. WCDMA.....	35
8.1.3. LTE BAND 5.....	36

8.1.4.	LTE BAND 41	38
8.2.	BAND EDGE AND EMISSION MASK	40
8.2.1.	GSM850	41
8.2.2.	GSM1900	42
8.2.3.	WCDMA BAND5	43
8.2.4.	WCDMA BAND2	44
8.2.5.	LTE BAND 5 BANDEDGE	45
8.2.6.	LTE BAND 41 ADJACENT CHANNEL POWER	53
8.3.	OUT OF BAND EMISSIONS	61
8.3.1.	GSM850	62
8.3.2.	GSM1900	64
8.3.3.	WCDMA BAND5	66
8.3.4.	WCDMA BAND2	68
8.3.5.	LTE BAND 5.....	70
8.3.6.	LTE BAND 41.....	74
8.4.	FREQUENCY STABILITY	78
8.4.1.	GSM.....	79
8.4.2.	WCDMA	81
8.4.3.	LTE BAND 5.....	83
8.4.4.	LTE BAND 41.....	84
8.5.	PEAK TO AVERAGE RATIO.....	85
8.5.1.	GSM.....	86
8.5.2.	WCDMA	87
8.5.3.	LTE BAND 5.....	88
8.5.4.	LTE BAND 41.....	90
9.	RADIATED TEST RESULTS	92
9.1.1.	GSM.....	95
9.1.2.	WCDMA	96
9.1.3.	LTE Band 5	97
9.1.4.	LTE Band 41	98
10.	APPENDIX A: PRE-SCAN DATA FOR 15B RECEIVER MODE	112
10.1.	GSM850	112
10.1.1.	BELOW 1GHz.....	112
10.1.2.	ABOVE 1GHz	118

11. SETUP PHOTOS..... 124



1. ATTESTATION OF TEST RESULTS

Applicant Name and Address	SAMSUNG ELECTRONICS CO., LTD. 129 SAMSUNG-RO, YEONGTONG-GU, SUWON-SI, GYEONGGI-DO, 16677, KOREA
Model	SM-A305F/DS AND SM-A305F
FCC ID	A3LSMA305F
EUT Description	GSM/WCDMA/LTE PHONE WITH BT, DTS/UNII A/B/G/N/AC AND ANT+
Serial Number	R38KC08WKCB(CONDUCTED) R38KC08WJSN(RADIATED)
Date Tested	JANUARY 14, 2019 to FEBRUARY 07, 2019
Applicable Standards	FCC CFR 47 PART 15B, 22H, 24E, 27F
Test Results	Complies

UL Verification Services Inc. tested the above equipment in accordance with the requirements set forth in the above standards. The test results show that the equipment tested is capable of demonstrating compliance with the requirements as documented in this report.

The results documented in this report apply only to the tested sample, under the conditions and modes of operation as described herein. It is the manufacturer's responsibility to assure that additional production units of this model are manufactured with identical electrical and mechanical components. All samples tested were in good operating condition throughout the entire test program. Measurement Uncertainties are published for informational purposes only and were not taken into account unless noted otherwise.

This document may not be altered or revised in any way unless done so by UL Verification Services Inc. and all revisions are duly noted in the revisions section. Any alteration of this document not carried out by UL Verification Services Inc. will constitute fraud and shall nullify the document. This report must not be used by the client to claim product certification, approval, or endorsement by NVLAP, NIST, any agency of the Federal Government, or any agency of the U.S. government.

Approved & Released For UL Verification Services Inc. By: 	Reviewed By: 
Dan Corona Operations Leader Consumer Technology Division UL Verification Services Inc.	Steven Tran Project Engineer Consumer Technology Division UL Verification Services Inc.

2. TEST METHODOLOGY

The tests documented in this report were performed in accordance with ANSI C63.26:2015, ANSI C63.4:2014, TIA-603-E, FCC CFR 47 Part 2, Part 15, Part 22, Part 24, Part 27, FCC KDB 971168 D01 v3r1.

3. FACILITIES AND ACCREDITATION

The test sites and measurement facilities used to collect data are located at 47173 and 47266 Benicia Street, and 47658 Kato Road, Fremont, California, USA. Line conducted emissions are measured only at the 47173 address. The following table identifies which facilities were utilized for radiated emission measurements documented in this report. Specific facilities are also identified in the test results sections.

47173 Benicia Street	47266 Benicia Street	47658 Kato Rd
<input type="checkbox"/> Chamber A (ISED:2324B-1)	<input type="checkbox"/> Chamber D (ISED:22541-1)	<input checked="" type="checkbox"/> Chamber I (ISED:2324A-5)
<input checked="" type="checkbox"/> Chamber B (ISED:2324B-2)	<input type="checkbox"/> Chamber E (ISED:22541-2)	<input checked="" type="checkbox"/> Chamber J (ISED:2324A-6)
<input type="checkbox"/> Chamber C (ISED:2324B-3)	<input type="checkbox"/> Chamber F (ISED:22541-3)	<input checked="" type="checkbox"/> Chamber K (ISED:2324A-1)
	<input type="checkbox"/> Chamber G (ISED:22541-4)	<input type="checkbox"/> Chamber L (ISED:2324A-3)
	<input type="checkbox"/> Chamber H (ISED:22541-5)	

The above test sites and facilities are covered under FCC Test Firm Registration # 208313. Chambers above are covered under Industry Canada company address and respective code

UL Verification Services Inc. is accredited by NVLAP, Laboratory Code 200065-0

4. CALIBRATION AND UNCERTAINTY

4.1. MEASURING INSTRUMENT CALIBRATION

The measuring equipment utilized to perform the tests documented in this report has been calibrated in accordance with the manufacturer's recommendations, and is traceable to recognized national standards.

4.2. SAMPLE CALCULATION

RADIATED EMISSIONS

Where relevant, the following sample calculation is provided:

$$\text{Field Strength (dBuV/m)} = \text{Measured Voltage (dBuV)} + \text{Antenna Factor (dB/m)} + \text{Cable Loss (dB)} - \text{Preamp Gain (dB)}$$
$$36.5 \text{ dBuV} + 18.7 \text{ dB/m} + 0.6 \text{ dB} - 26.9 \text{ dB} = 28.9 \text{ dBuV/m}$$

MAINS CONDUCTED EMISSIONS

Where relevant, the following sample calculation is provided:

$$\text{Final Voltage (dBuV)} = \text{Measured Voltage (dBuV)} + \text{Cable Loss (dB)} + \text{Limiter Factor (dB)} + \text{LISN Insertion Loss.}$$
$$36.5 \text{ dBuV} + 0 \text{ dB} + 10.1 \text{ dB} + 0 \text{ dB} = 46.6 \text{ dBuV}$$

4.3. MEASUREMENT UNCERTAINTY

Where relevant, the following measurement uncertainty levels have been estimated for tests performed on the apparatus:

PARAMETER	UNCERTAINTY
Worst Case Conducted Disturbance, 9KHz to 0.15 MHz	3.84 dB
Worst Case Conducted Disturbance, 0.15 to 30 MHz	3.65 dB
Worst Case Radiated Disturbance, 9KHz to 30 MHz	3.15 dB
Worst Case Radiated Disturbance, 30 to 1000 MHz	5.36 dB
Worst Case Radiated Disturbance, 1000 to 18000 MHz	4.32 dB
Worst Case Radiated Disturbance, 18000 to 26000 MHz	4.45 dB
Worst Case Radiated Disturbance, 26000 to 40000 MHz	5.24 dB

Uncertainty figures are valid to a confidence level of 95%.

5. EQUIPMENT UNDER TEST

5.1. DESCRIPTION OF EUT

The EUT is a GSM/WCDMA/LTE phone with BT, DTS/UNII a/b/g/n/ac and ANT+. The model SM-A305F/DS was used for final testing and is representative of the test results in this report.

5.2. MAXIMUM OUTPUT POWER

ERP/EIRP LIMIT

FCC: §2.1046, §22.913, §24.232, §27.50

EIRP/ERP TEST PROCEDURE

ANSI C63.26:2015/ TIA-603-E Clause 2.2.17

KDB 971168 D01 Section 5.6

KDB 412172 D01

$$\text{ERP/EIRP} = \text{PMeas} + \text{GT} - \text{LC}$$

where: ERP/EIRP = effective or equivalent radiated power, respectively (expressed in the same units as PMeas, typically dBW or dBm);

PMeas = measured transmitter output power or PSD, in dBm or dBW;

GT = gain of the transmitting antenna, in dBd (ERP) or dBi (EIRP);

LC = signal attenuation in the connecting cable between the transmitter and antenna, in dB.

For devices utilizing multiple antennas, KDB 662911 provides guidance for determining the effective array transmit antenna gain term to be used in the above equation.

The transmitter has a maximum average conducted and ERP / EIRP output powers as follows:

GSM MODES

Part 22 850MHz								
Frequency range (MHz)	Modulation	Conducted (Average) (dBm)	Antenna Gain (dBi)	Limit (W)	ERP		99% BW (kHz)	Emission Designator
					(dBm)	(W)		
824.2-848.8	GPRS	32.7	-2.20	7.0	28.35	0.684	237.05	237KGXW
	EGPRS	26.5			22.15	0.164	238.78	239KG7W

Part 24 1900MHz								
Frequency range (MHz)	Modulation	Conducted (Average) (dBm)	Antenna Gain (dBi)	Limit (W)	EIRP		99% BW (kHz)	Emission Designator
					(dBm)	(W)		
1850.2-1909.8	GPRS	29.9	1.30	2.0	31.20	1.318	238.44	238KGXW
	EGPRS	26.3			27.60	0.575	242.01	242KG7W

WCDMA MODE

Part 22 Band 5								
Frequency range (MHz)	Modulation	Conducted (Average) (dBm)	Antenna Gain (dBi)	Limit (W)	ERP		99% BW (kHz)	Emission Designator
					(dBm)	(W)		
826.4-846.6	REL 99	24.7	-2.20	7.0	20.35	0.108	4170	4M17F9W
	HSDPA	23.4			19.05	0.080	4140	4M14F9W

Part 24 Band 2								
Frequency range (MHz)	Modulation	Conducted (Average) (dBm)	Antenna Gain (dBi)	Limit (W)	ERP		99% BW (kHz)	Emission Designator
					(dBm)	(W)		
1852.4-1907.6	REL 99	25.2	1.30	2.0	26.50	0.447	4140	4M14F9W
	HSDPA	25.3			26.60	0.457	4140	4M14F9W

LTE BAND 5

Part 22H								
ERP Limit (W)		7.00						
Antenna Gain (dBi)		-2.20						
Bandwidth (MHz)	Modulation	Low Frequency (MHz)	Upper Frequency (MHz)	Conducted Average (dBm)	ERP Average (dBm)	ERP Average (W)	99% BW (kHz)	Emission Designator
1.4	QPSK	824.7	848.3	23.8	19.45	0.088	1090	1M09G7W
	16QAM			22.6	18.25	0.067	1080	1M08D7W
3.0	QPSK	825.5	847.5	23.9	19.55	0.090	2690	2M69G7W
	16QAM			23.0	18.65	0.073	2700	2M70D7W
5.0	QPSK	826.5	846.5	23.8	19.45	0.088	4510	4M51G7W
	16QAM			22.8	18.45	0.070	4510	4M51D7W
10.0	QPSK	829.0	844.0	24.5	20.15	0.104	8960	8M96G7W
	16QAM			23.5	19.15	0.082	8970	8M97D7W

LTE BAND 41

Part 27								
EIRP Limit (W)		2.00						
Antenna Gain (dBi)		-1.40						
Bandwidth (MHz)	Modulation	Low Frequency (MHz)	Upper Frequency (MHz)	Conducted Average (dBm)	EIRP Average (dBm)	EIRP Average (W)	99% BW (kHz)	Emission Designator
5.0	QPSK	2498.5	2687.5	23.5	22.10	0.162	4530	4M53G7W
	16QAM			22.8	21.40	0.138	4490	4M49D7W
10.0	QPSK	2501.0	2685.0	23.5	22.10	0.162	8970	8M97G7W
	16QAM			22.6	21.20	0.132	8960	8M96D7W
15.0	QPSK	2503.5	2682.5	23.5	22.10	0.162	13440	13M4G7W
	16QAM			22.7	21.30	0.135	13440	13M4D7W
20.0	QPSK	2506.0	2680.0	23.5	22.10	0.162	17820	17M8G7W
	16QAM			22.9	21.50	0.141	17850	17M9D7W

5.3. SOFTWARE AND FIRMWARE

The test utility software used during testing was A305F.001

5.4. MAXIMUM ANTENNA GAIN

Please see table below:

LTE Bands	Antenna Gain (dBi)
GSM850, 824-849MHz	-2.2
GSM1900, 1850-1910MHz	1.3
WCDMA Band 2, 1850-1910 MHz	1.3
WCDMA Band 5, 824-849 MHz	-2.2
LTE BAND 5, 824 - 849 MHz	-2.2
LTE BAND 41 (FCC), 2496 - 2690 MHz	-1.4

5.5. WORST-CASE CONFIGURATION AND MODE

The EUT supports LTE Bands of:
Band 5 and Band 41

The worst-case scenario for all measurements is based on the average conducted output power measurement investigation results. Output power measurements were measured on QPSK and 16QAM modulations. All testing was performed using QPSK, and 16QAM modulations to represent the worst case.

The fundamental of the EUT was investigated in three orthogonal orientations X, Y, & Z, and it was determined that X position for 850/1900MHz was worst-case orientation. And Y position for 2500MHz.

All radios that can be transmitted simultaneously have been evaluated for radiated for all possible combinations of transmission and found to be in compliance.

For check the Part15B receiver mode (Appendix A):

GSM850 (Frequency range: 869-894 MHz) cover WCDMA B5 and LTE Band 5 due to overlapping frequency range. The low, middle, and high channel were set to test and spurious emissions was investigated in three orthogonal orientations X, Y and Z it was determined that X orientation was worst-case orientation.

5.6. DESCRIPTION OF TEST SETUP

SUPPORT EQUIPMENT

Support Equipment List				
Description	Manufacturer	Model	Serial Number	FCC ID
AC Adapter	Samsung	EP-TA50EWE	DW3J719AS/A-E	N/A
Earphone	Samsung	N/A	N/A	N/A

I/O CABLES (RF Conducted Test)

I/O Cable List						
Cable No	Port	# of identical ports	Connector Type	Cable Type	Cable Length (m)	Remarks
1	RF Out	1	Spectrum Analyzer	Shielded	None	NA
2	Antenna Port	1	EUT	Shielded	0.1m	NA
3	RF In/Out	1	Communication Test Set	Shielded	1m	NA

I/O CABLES (RF Radiated Test)

I/O Cable List						
Cable No	Port	# of identic	Connector Type	Cable Type	Cable Length	Remarks
1	USB	1	AC Adapter	Un-shielded	1.2m	No
2	Earphone	1	USB	Un-shielded	1m	No
3	RF In/out	1	Communication Test Set	Un-shielded	2m	No

TEST SETUP

The EUT is continuously communicated to the call box during the tests

CONDUCTED TEST SETUP DIAGRAM

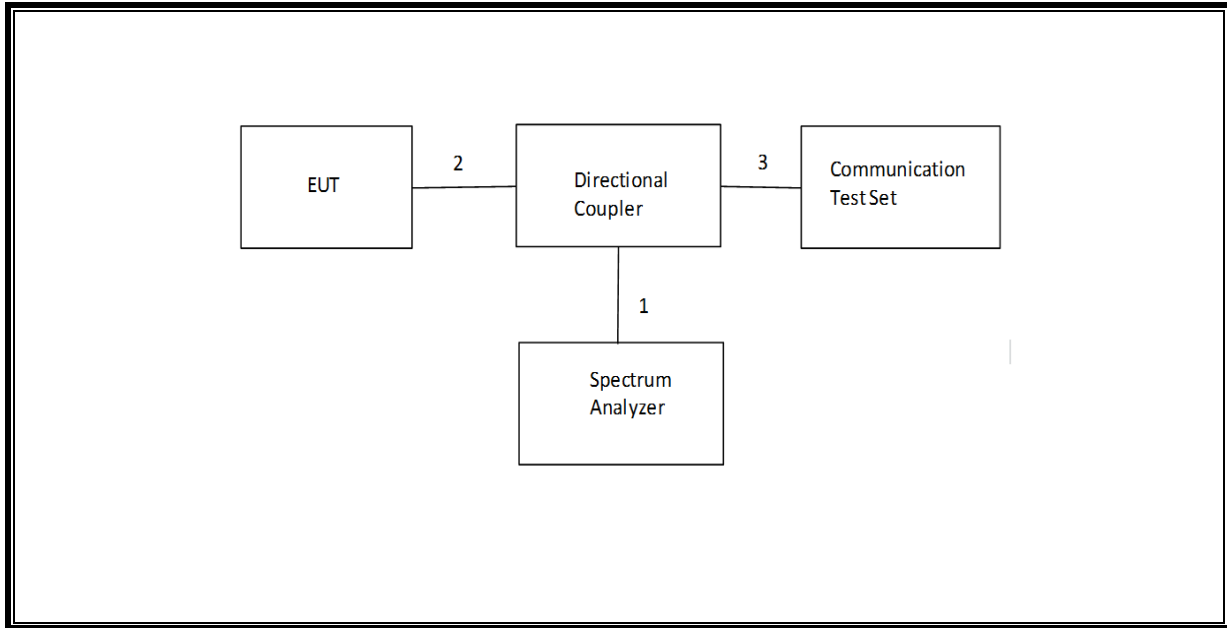

RADIATED TEST SETUP DIAGRAM

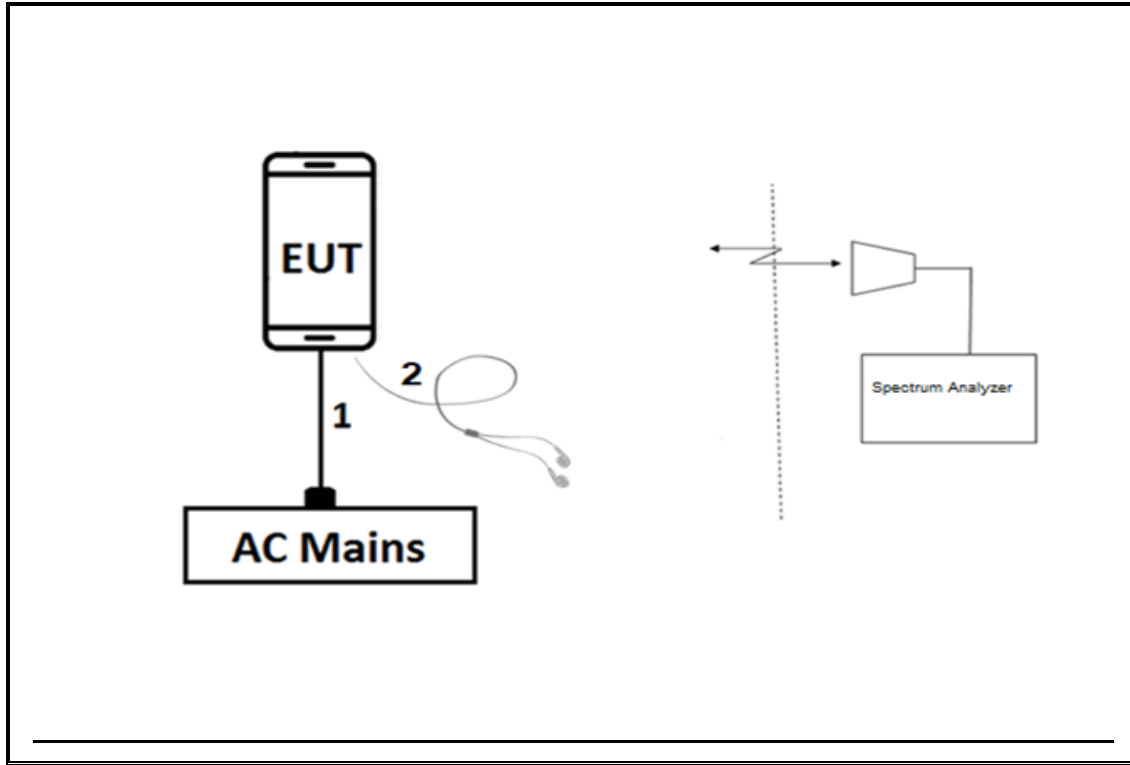

6. TEST AND MEASUREMENT EQUIPMENT

The following test and measurement equipment was utilized for the tests documented in this report:

TEST EQUIPMENT LIST					
Description	Manufacturer	Model	ID Num	Cal Due	Last Cal
Highpass Filter, 2.7 GHz	Micro-Circuits	H2G518G6	T772	07/05/19	07/05/18
Highpass Filter, 1 GHz	Micro-Tronics	HPM18129	T889	02/21/19	02/21/18
Highpass Filter, 1.5 GHz	Micro-Tronics	HPM50114	T1852	07/16/19	07/16/18
Highpass Filter, 4GHz	Micro-Tronics	HPM13351	T1241	07/19/19	07/19/18
Antenna, Horn 1-18GHz	ETS-Lindgren	3117	T344	04/30/19	04/30/18
Antenna, Horn 1-18GHz	ETS-Lindgren	3117	T862	05/24/19	05/24/18
Antenna, Horn 1-18GHz	ETS-Lindgren	3117	T863	06/21/19	06/21/18
Antenna, Horn 1-18GHz	ETS-Lindgren	3117	AT0067	03/26/19	03/26/18
Antenna, Horn 18 - 26.5 GHz	ARA	MWH-1826/B	T477	06/16/2019	06/16/2018
Hybrid Antenna	Sunol Sciences Corp.	JB3	T407	05/10/19	05/10/18
Hybrid Antenna	SunAR rf motion	JB3	PRE0184971	11/13/19	11/13/18
Hybrid Antenna	SunAR rf motion	JB3	PRE0181575	08/01/19	08/01/18
RF Amplifier	MITEQ	AFS42-00101800-25-S-42	174060	08/01/19	08/01/18
RF Amplifier	MITEQ	AFS42-00101800-25-S-42	T493	10/13/19	10/13/18
RF Amplifier	AMPLICAL	AMP1G18-35	T1571	07/30/19	07/30/18
RF Amplifier	AMPLICAL	AMP1G18-35	T1569	06/03/19	06/03/18
Directional Coupler	Mini-Circuits	ZUDC10-183+	T1136	06/18/19	06/18/18
Wideband Communication Test Set, Call Box	R&S	CMW500	T972	05/29/19	05/29/18
Wideband Communication Test Set, Call Box	R&S	CMW500	T1872	02/15/19	02/15/18
Wideband Communication Test Set, Call Box	R&S	CMW500	T949	02/21/19	02/21/18
Chamber, Environmental	Thermotron	SE-600-10-10	T80	02/22/19	02/22/18
Spectrum Analyzer	Agilent (Keysight) Technologies	E4446A	T146	07/18/19	07/18/18
EMI TEST RECEIVER	Rohde & Schwarz	ESW44	PRE0179375	05/08/19	05/08/18
EMI TEST RECEIVER	Rohde & Schwarz	ESW44	PRE0179372	05/04/19	05/04/18
EMI TEST RECEIVER	Rohde & Schwarz	ESW44	PRE0179367	04/25/19	04/25/18
Spectrum Analyzer, PXA, 3Hz to 44GHz	Agilent (Keysight) Technologies	N9030A	T1454	01/25/20	01/25/19
Spectrum Analyzer, PXA, 3Hz to 44GHz	Agilent (Keysight) Technologies	N9030A	T1466	04/16/19	04/16/18
DC power supply, 8 V @ 3 A or 15 V @ 2 A	Agilent / HP	E3610A	None	CNR	CNR
DC power supply 15V	Sprensen	XT15-4	T463	CNR	CNR
Power Meter	Keysight	N1911A	T1268	06/25/2019	06/25/2018
Power Sensor	Keysight	N1921A	T1228	07/10/2019	07/10/2018

UL AUTOMATION SOFTWARE			
CLT Software	UL	UL RF	Ver 7.6, November 11, 2017
Power Measurement Software	UL	UL RF	Ver 2.2, June 2017

NOTES:

- Equipment listed above that calibrated during the testing period was set for test after the calibration.
- Equipment listed above that has a calibration due date during the testing period, the testing is completed before equipment expiration date.