



**FCC CFR47 PART 22 SUBPART H
FCC CFR47 PART 24 SUBPART E**

CERTIFICATION TEST REPORT

For

GSM/WCDMA/LTE Phone + Bluetooth, WLAN 2.4GHz b/g/n, ANT+ & NFC

MODEL NUMBER: SM-A300FU

FCC ID: A3LSMA300FU

REPORT NUMBER: 14119248-E1 REVISION C

ISSUE DATE: DECEMBER 2, 2014

Prepared for

**SAMSUNG ELECTRONICS CO., LTD.
416, MAETAN 3-DONG, YEONGTONG-GU
SUWON-CITY, GYEONGGI-DO 443-742, SOUTH KOREA**

Prepared by

**UL VERIFICATION SERVICES
47173 BENICIA STREET
FREMONT, CA 94538, U.S.A.
TEL: (510) 771-1000
FAX: (510) 661-0888**



NVLAP LAB CODE 200065-0

Revision History

Rev.	Date	Revisions	Revised By
--	11/3/14	Initial Issue	P. Zhang
A	11/21/14	Updated antenna information	P. Zhang
B	11/24/14	Updated antenna information page 10	D. Corona
C	12/2/14	Updated page 13 and page 3	P. Zhang

TABLE OF CONTENTS

1.	ATTESTATION OF TEST RESULTS	5
2.	TEST METHODOLOGY	6
3.	FACILITIES AND ACCREDITATION	6
4.	CALIBRATION AND UNCERTAINTY	6
4.1.	MEASURING INSTRUMENT CALIBRATION	6
4.2.	SAMPLE CALCULATION	6
4.3.	MEASUREMENT UNCERTAINTY	7
5.	EQUIPMENT UNDER TEST	8
5.1.	DESCRIPTION OF EUT	8
5.2.	MAXIMUM OUTPUT POWER	8
5.3.	MAXIMUM OUTPUT POWER (LTE)	9
5.4.	DESCRIPTION OF AVAILABLE ANTENNAS	10
5.5.	DESCRIPTION OF TEST SETUP	11
6.	TEST AND MEASUREMENT EQUIPMENT	14
7.	Summary Table	15
8.	RF POWER OUTPUT VERIFICATION	16
8.1.	GSM/GPRS/EDGE	16
8.1.1.	GSM OUTPUT POWER RESULT	17
8.2.	UMTS REL 99	19
8.2.1.	UMTS REL 99 OUTPUT POWER RESULT	19
8.3.	UMTS HSDPA	20
8.3.1.	UMTS HSDPA OUTPUT POWER RESULT	21
8.4.	UMTS HSUPA	22
8.4.1.	UMTS HSUPA OUTPUT POWER RESULT	23
8.5.	LTE OUTPUT VERIFICATION	27
8.5.1.	LTE OUTPUT RESULT	27
9.	PEAK TO AVERAGE RATIO	29
9.1.	CONDUCTED PEAK TO AVERAGE RESULT	29
9.1.1.	WCDMA	29
9.1.2.	LTE Band 5	31
9.1.3.	GSM	33
10.	LIMITS AND CONDUCTED RESULTS	34

10.1. OCCUPIED BANDWIDTH 34
 10.1.1. OCCUPIED BANDWIDTH RESULTS 35
 10.1.2. LTE OCCUPIED BANDWIDTH RESULTS 37
 10.1.1. OCCUPIED BANDWIDTH PLOTS 39
10.2. BAND EDGE EMISSIONS 44
 10.2.1. BAND EDGE PLOTS 45
10.3. OUT OF BAND EMISSIONS 57
 10.3.1. OUT OF BAND EMISSIONS RESULT 58
 10.3.2. OUT OF BAND EMISSIONS PLOTS 61
10.4. FREQUENCY STABILITY 65
 10.4.1. FREQUENCY STABILITY RESULTS 66
11. RADIATED TEST RESULTS 68
 11.1. RADIATED POWER (ERP & EIRP) 68
 11.1.1. ERP/EIRP Results 69
 11.1.2. LTE ERP/EIRP Results 70
 11.1.3. ERP/EIRP DATA 72
 11.2. FIELD STRENGTH OF SPURIOUS RADIATION 88
 11.2.1. SPURIOUS RADIATION DATA 89
12. SETUP PHOTOS 105

1. ATTESTATION OF TEST RESULTS

COMPANY NAME: SAMSUNG ELECTRONICS CO., LTD.
EUT DESCRIPTION: GSM/WCDMA/LTE Phone + Bluetooth, WLAN DTS b/g/n, ANT+ & NFC
MODEL: SM-A300FU
SERIAL NUMBER: 1951552 (Conducted); 1987515, 1987514 (Radiated)
DATE TESTED: September 4 – November 3, 2014

APPLICABLE STANDARDS	
STANDARD	TEST RESULTS
FCC PART 22H and 24E	PASS

UL Verification Services Inc. tested the above equipment in accordance with the requirements set forth in the above standards. All indications of Pass/Fail in this report are opinions expressed by UL Verification Services Inc. based on interpretations and/or observations of test results. Measurement Uncertainties were not taken into account and are published for informational purposes only. The test results show that the equipment tested is capable of demonstrating compliance with the requirements as documented in this report.

Note: The results documented in this report apply only to the tested sample, under the conditions and modes of operation as described herein. This document may not be altered or revised in any way unless done so by UL Verification Services Inc. and all revisions are duly noted in the revisions section. Any alteration of this document not carried out by UL Verification Services Inc. will constitute fraud and shall nullify the document. This report must not be used by the client to claim product certification, approval, or endorsement by NVLAP, NIST, any agency of the Federal Government, or any agency of any government.

Approved & Released For
UL Verification Services Inc. By:

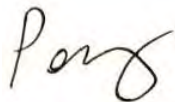

PENG ZHANG
CONSUMER TECHNOLOGY DIVISION
PROJECT LEAD
UL Verification Services Inc.

Tested By:



R. ALEGRE
CONSUMER TECHNOLOGY DIVISION
LAB TECHNICIAN
UL Verification Services Inc.

2. TEST METHODOLOGY

The tests documented in this report were performed in accordance with TIA-603-C, FCC CFR 47 Part 22 and FCC CFR Part 24.

3. FACILITIES AND ACCREDITATION

The test sites and measurement facilities used to collect data are located at 47173 and 47266 Benicia Street, Fremont, California, USA. Line conducted emissions are measured only at the 47173 address. The following table identifies which facilities were utilized for radiated emission measurements documented in this report. Specific facilities are also identified in the test results sections.

47173 Benicia Street	47266 Benicia Street
<input type="checkbox"/> Chamber A(IC: 2324B-1)	<input type="checkbox"/> Chamber D(IC: 2324B-4)
<input checked="" type="checkbox"/> Chamber B(IC: 2324B-2)	<input type="checkbox"/> Chamber E(IC: 2324B-5)
<input checked="" type="checkbox"/> Chamber C(IC: 2324B-3)	<input type="checkbox"/> Chamber F(IC: 2324B-6)
	<input type="checkbox"/> Chamber G(IC: 2324B-7)
	<input type="checkbox"/> Chamber H(IC: 2324B-8)

UL Verification Services Inc. is accredited by NVLAP, Laboratory Code 200065-0. The full scope of accreditation can be viewed at <http://ts.nist.gov/standards/scopes/2000650.htm>.

4. CALIBRATION AND UNCERTAINTY

4.1. MEASURING INSTRUMENT CALIBRATION

The measuring equipment utilized to perform the tests documented in this report has been calibrated in accordance with the manufacturer's recommendations, and is traceable to recognized national standards

4.2. SAMPLE CALCULATION

Where relevant, the following sample calculation is provided:

$$\text{EIRP} = \text{PSA reading with EUT worst orientation (dBm)} + \text{Path loss (dB)} - \text{cable loss (between the SG and substitution antenna)} + \text{Substitution Antenna Factor (dBi)}$$

$$\text{ERP} = \text{PSA reading with EUT worst orientation (dBm)} + \text{Path loss (dB)} - \text{cable loss (between the SG and substitution antenna)}$$

(Path loss = Signal generator output – PSA reading with substitution antenna)

4.3. MEASUREMENT UNCERTAINTY

Where relevant, the following measurement uncertainty levels have been estimated for tests performed on the apparatus:

PARAMETER	UNCERTAINTY
Conducted Disturbance, 0.15 to 30 MHz	3.52 dB
Radiated Disturbance, 30 to 27000 MHz	4.94 dB

Uncertainty figures are valid to a confidence level of 95%.

5. EQUIPMENT UNDER TEST

5.1. DESCRIPTION OF EUT

The EUT is a GSM/WCDMA/LTE Phone + Bluetooth, WLAN 2.4GHz b/g/n, ANT+ & NFC.

5.2. MAXIMUM OUTPUT POWER

The transmitter has a maximum peak conducted and radiated ERP / EIRP output powers as follows:

FCC Part 22/24						
Band	Frequency Range(MHz)	Modulation	Conducted		Radiated	
			AVG(dBm)	AVG (mW)	AVG(dBm)	AVG (mW)
GSM850	824~849	GMSK	33.2	2089.30		
	824~849	GPRS	33.2	2089.30	25.70	371.5
	824~849	EGPRS	27.2	524.81	22.00	158.5
GSM1900	1850~1910	GMSK	29.7	933.25		
	1850~1910	GPRS	29.7	933.25	26.77	475.3
	1850~1910	EGPRS	25.8	380.19	23.57	227.5
Band 5	824~849	REL99	23.1	204.17	15.60	36.3
	824~849	HSDPA	22.2	165.96	14.15	26.0
	824~849	HSUPA	22.2	165.96		
	824~849	DC-HSDPA	22.2	165.96		
Band 2	1850~1910	REL99	23.3	213.80	21.05	127.4
	1850~1910	HSDPA	21.4	138.04	20.16	103.8
	1850~1910	HSUPA	21.3	134.90		
	1850~1910	DC-HSDPA	21.3	134.90		

5.3. MAXIMUM OUTPUT POWER (LTE)

The transmitter has a maximum peak conducted and radiated ERP/EIRP output powers as follows:

FCC Part 22/24							
Band	Frequency Range(MHz)	BandWidth (MHz)	Modulation	Conducted		Radiated	
				dBm	mW	dBm	mW
LTE5	824~849	10MHz	QPSK	23.0	199.53	15.85	38.46
	824~849	10MHz	16QAM	22.0	158.49	14.78	30.06

FCC Part 22/24							
Band	Frequency Range(MHz)	BandWidth (MHz)	Modulation	Conducted		Radiated	
				dBm	mW	dBm	mW
LTE5	824~849	5MHz	QPSK	23.0	199.53	15.27	33.65
	824~849	5MHz	16QAM	22.0	158.49	14.47	27.99

FCC Part 22/24							
Band	Frequency Range(MHz)	BandWidth (MHz)	Modulation	Conducted		Radiated	
				dBm	mW	dBm	mW
LTE5	824~849	3MHz	QPSK	23.0	199.53	15.21	33.19
	824~849	3MHz	16QAM	22.0	158.49	14.44	27.80

FCC Part 22/24							
Band	Frequency Range(MHz)	BandWidth (MHz)	Modulation	Conducted		Radiated	
				dBm	mW	dBm	mW
LTE5	824~849	1.4MHz	QPSK	23.0	199.53	15.79	37.93
	824~849	1.4MHz	16QAM	22.0	158.49	14.31	26.98

5.4. DESCRIPTION OF AVAILABLE ANTENNAS

The radio utilizes a PIFA antenna for the [List the bands supported] with a maximum peak gain as follow:

Frequency (MHz)	Peak Gain (dBi)
Band 5, 824~849MHz	-2.2
Band 2, 1850~1910MHz	-2.8

5.5. DESCRIPTION OF TEST SETUP

SUPPORT EQUIPMENT

Support Equipment List				
Description	Manufacturer	Model	Serial Number	FCC ID
AC Adapter	Samsung	ETA0U83EWE	N/A	N/A
Earphone	Samsung	EHS64AVFWE	N/A	N/A

I/O CABLES (CONDUCTED SETUP)

I/O Cable List						
Cable No	Port	# of identical ports	Connector Type	Cable Type	Cable Length (m)	Remarks
1	RF Out	1	Spectrum Analyzer	Shielded	None	NA
2	Antenna Port	1	EUT	Shielded	0.1m	NA
3	RF In/Out	1	Communication Test Set	Shielded	1m	NA

I/O CABLES (RADIATED SETUP)

I/O CABLE LIST						
Cable No.	Port	# of Identical Ports	Connector Type	Cable Type	Cable Length	Remarks
1	USB	1	AC Adapter	Un-shielded	1.2m	No
2	Jack	1	Headset	Shielded	1m	No
3	RF In/out	1	Communication Test Set	Un-shielded	2m	Yes

TEST SETUP

The EUT is continuously communicated to the call box during the tests.

SETUP DIAGRAM FOR TESTS (CONDUCTED TEST SETUP)

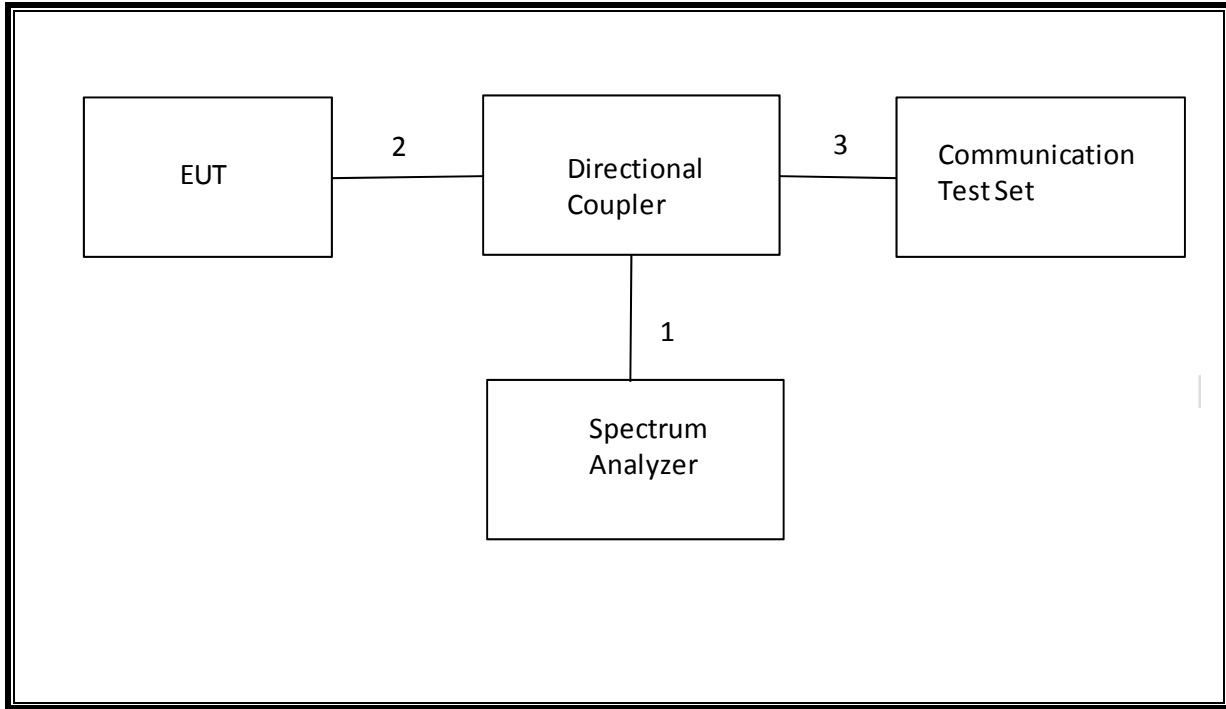

SETUP DIAGRAM FOR TESTS (RADIATED TEST SETUP)

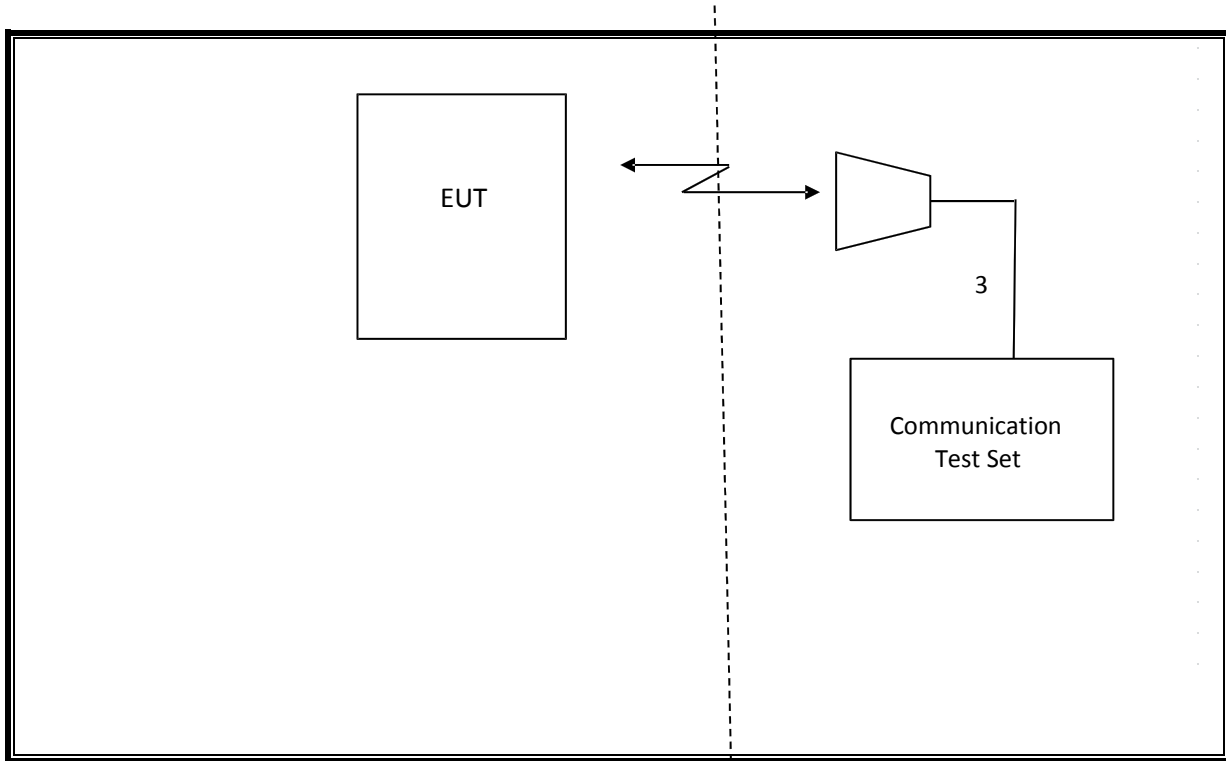

6. TEST AND MEASUREMENT EQUIPMENT

The following test and measurement equipment was utilized for the tests documented in this report:

TEST EQUIPMENT LIST				
Description	Manufacturer	Model	Asset	Cal Due
Spectrum Analyzer, 44 GHz	Agilent / HP	E4446A	C01179	02/26/15
Antenna, Bilog, 2 GHz	Sunol Sciences	JB1	C01011	08/14/15
Antenna, Horn, 18 GHz	EMCO	3115	C00783	10/25/15
Antenna, Horn, 18 GHz	EMCO	3115	C00784	10/25/15
Highpass Filter, 2.7 GHz	Micro-Tronics	HPM13194	N02687	CNR
Highpass Filter, 1.5 GHz	Micro-Tronics	HPM13193	N02688	CNR
Temperature / Humidity Chamber	Thermotron	SE 600-10-10	C00930	01/09/15
Communications Test Set	R&S	CMW500	T159	07/02/15
DC power supply, 8 V @ 3 A or 15 V	Agilent / HP	E3610A	None	CNR
Vector signal generator, 6 GHz	Agilent / HP	E4438C	None	07/06/15
Antenna, Tuned Dipole 400~1000	ETS	3121C DB4	C00993	02/14/15
Directional Coupler	RF-Lambda	RFDC5M06G15	None	CNR
Antenna, Horn, 26.5 GHz	ARA	MWH-1826/B	C00589	12/17/14

7. Summary Table

FCC Part Section	RSS Section(s)	Test Description	Test Limit	Test Condition	Test Result	Worst Case
2.1049	N/A	Occupied Band width (99%)	N/A	Conducted	Pass	8.983MHz
22.917(a) 24.238(a) 27.53(g) 90.691	RSS-132(4.5.1) RSS-133(6.5.1) RSS-139(6.5.1)	Band Edge / Conducted Spurious Emission	-13dBm		Pass	-18.62dBm
2.1046	N/A	Conducted output power	N/A		Pass	33.5dBm
22.355 24.235 27.54 90.213	RSS-132(4.3) RSS-133(6.3) RSS-139(6.3) RSS-199(4.3)	Frequency Stability	2.5PPM		Pass	0.07PPM
22.913(a)(2)	RSS-132(4.4)	Effective Radiated Power	38 dBm	Radiated	Pass	25.70dBm
24.232(c) 27.50(h)(2)	RSS-133(6.4) RSS-199(4.4)	Equivalent Isotropic Radiated Power	33dBm		Pass	26.77dBm
22.917(a) 24.238(a) 27.53(g)	RSS-132(4.5.1) RSS-133(6.5.1) RSS-139(6.5.1)	Radiated Spurious Emission	-13dBm		Pass	-43.3dBm

8. RF POWER OUTPUT VERIFICATION

8.1. GSM/GPRS/EDGE

Function: Menu select > GSM Mobile Station > GSM 850/900/1800/1900
Press Connection control to choose the different menus
Press RESET > choose all to reset all settings
Connection Press Signal Off to turn off the signal and change settings
Network Support > GSM+GPRS or GSM+EGPRS
Main Service > Packet Data
Service selection > Test Mode A – Auto Slot Config. off
MS Signal Press Slot Config bottom on the right twice to select and change the number of time slots and power setting
 > Slot configuration > Uplink/Gamma
 > 33 dBm for GPRS 850/900
 > 30 dBm for GPRS1800/1900
BS Signal Enter the same channel number for TCH channel (test channel) and BCCH channel
Frequency Offset > + 0 Hz
Mode > BCCH and TCH
BCCH Level > -85 dBm (May need to adjust if link is not stable)
BCCH Channel > choose desire test channel [Enter the same channel number for TCH channel (test channel) and BCCH channel]
Channel Type > Off
P0> 4 dB
Slot Config > Unchanged (if already set under MS Signal)
TCH > choose desired test channel
Hopping > Off
Main Timeslot > 3 (Default)
Network Coding Scheme > CS4 (GPRS) and MCS5 ~ MCS9 (EGPRS)
 Bit Stream > 2E9-1PSR Bit Pattern
AF/RF Enter appropriate offsets for Ext. Att. Output and Ext. Att. Input
Connection Press Signal On to turn on the signal and change settings

8.1.1. GSM OUTPUT POWER RESULT

Band	Mode	Coding Scheme	Time Slots	Ch No.	Freq. (MHz)	Burst Pw r (dBm)	Frame Pw r (dBm)	
850	GSM (Voice)	CS1	1	128	824.2	33.1	24.1	
				190	836.6	33.2	24.2	
				251	848.8	32.8	23.8	
	GPRS (GMSK)	CS1	1	1	128	824.2	33.1	24.1
					190	836.6	33.2	24.2
					251	848.8	32.8	23.8
				2	128	824.2	29.7	23.7
					190	836.6	29.7	23.7
					251	848.8	29.8	23.8
			3	128	824.2	29.0	24.7	
				190	836.6	29.0	24.7	
				251	848.8	29.0	24.7	
			4	128	824.2	27.0	24.0	
				190	836.6	27.0	24.0	
				251	848.8	27.0	24.0	
	EGPRS (8PSK)	MCS5	1	1	128	824.2	27.1	18.1
					190	836.6	27.1	18.1
					251	848.8	27.2	18.2
			2	1	128	824.2	26.8	20.8
					190	836.6	26.8	20.8
					251	848.8	26.8	20.8
			3	1	128	824.2	26.5	22.2
					190	836.6	26.4	22.1
					251	848.8	26.4	22.1
4			1	128	824.2	26.0	23.0	
				190	836.6	25.9	22.9	
				251	848.8	25.9	22.9	

Band	Mode	Coding Scheme	Time Slots	Ch No.	Freq. (MHz)	Burst Pwr (dBm)	Frame Pwr (dBm)			
1900	GSM (Voice)	CS1	1	512	1850.2	29.7	20.7			
				661	1880.0	29.7	20.7			
				810	1909.8	29.7	20.7			
	GPRS (GMSK)	CS1	1	1	512	1850.2	29.7	20.7		
					661	1880.0	29.7	20.7		
					810	1909.8	29.7	20.7		
			2	1	512	1850.2	26.7	20.7		
					661	1880.0	26.9	20.9		
					810	1909.8	26.8	20.8		
			3	1	512	1850.2	25.6	21.3		
					661	1880.0	25.7	21.4		
					810	1909.8	25.6	21.3		
			4	1	512	1850.2	23.3	20.3		
					661	1880.0	23.1	20.1		
					810	1909.8	23.1	20.1		
			EGPRS (8PSK)	MCS5	1	1	512	1850.2	25.6	16.6
							661	1880.0	25.8	16.8
							810	1909.8	25.6	16.6
	2	1			512	1850.2	25.4	19.4		
					661	1880.0	25.5	19.5		
					810	1909.8	25.2	19.2		
	3	1			512	1850.2	24.5	20.2		
					661	1880.0	24.5	20.2		
					810	1909.8	24.5	20.2		
	4	1			512	1850.2	23.3	20.3		
					661	1880.0	23.3	20.3		
					810	1909.8	23.1	20.1		

8.2. UMTS REL 99

TEST PROCEDURE

The following summary of these settings are illustrated below:

	Mode	Rel99
	Subtest	-
WCDMA General Settings	Loopback Mode	Test Mode 1
	Rel99 RMC	12.2kbps RMC
	HSDPA FRC	Not Applicable
	HSUPA Test	Not Applicable
	Power Control Algorithm	Algorithm2
	β_c	Not Applicable
	β_d	Not Applicable
	β_{ec}	Not Applicable
	β_c/β_d	8/15
	β_{hs}	Not Applicable
	β_{ed}	Not Applicable

8.2.1. UMTS REL 99 OUTPUT POWER RESULT

Band	Mode	UL Ch No.	Freq. (MHz)	Avg Pwr (dBm)
WCDMA Band V	Rel 99 (RMC, 12.2 kbps)	4132	826.4	23.1
		4183	836.6	23.0
		4233	846.6	23.0
WCDMA Band II	Rel 99 (RMC, 12.2 kbps)	9262	1852.4	23.0
		9400	1880.0	23.3
		9538	1907.6	23.3

8.3. UMTS HSDPA

The following 4 Sub-tests were completed according to Release 5 procedures in section 5.2 of 3GPP TS34.121. A summary of these settings are illustrated below:

	Mode	Rel5 HSDPA			
	Subtest	1	2	3	4
WCDMA General Settings	Loopback Mode	Test Mode 1			
	Rel99 RMC	12.2kbps RMC			
	HSDPA FRC	H-Set1			
	Power Control Algorithm	Algorithm 2			
	β_c	2/15	12/15	15/15	15/15
	β_d	15/15	15/15	8/15	4/15
	Bd (SF)	64			
	β_c/β_d	2/15	12/15	15/8	15/4
	β_{hs}	4/15	24/15	30/15	30/15
	MPR (dB)	0	0	0.5	0.5
HSDPA Specific Settings	D_{ACK}	8			
	D_{NAK}	8			
	DCQI	8			
	Ack-Nack repetition factor	3			
	CQI Feedback (Table 5.2B.4)	4ms			
	CQI Repetition Factor (Table 5.2B.4)	2			
	$A_{hs} = \beta_{hs}/\beta_c$	30/15			

8.3.1. UMTS HSDPA OUTPUT POWER RESULT

Band	Mode	UL Ch No.	Freq. (MHz)	MPR	Avg Pwr (dBm)
WCDMA Band V	Subtest 1	4132	826.4	0	22.1
		4183	836.6	0	22.2
		4233	846.6	0	22.2
	Subtest 2	4132	826.4	0	22.2
		4183	836.6	0	22.1
		4233	846.6	0	22.0
	Subtest 3	4132	826.4	0.5	21.5
		4183	836.6	0.5	21.5
		4233	846.6	0.5	21.5
	Subtest 4	4132	826.4	0.5	21.5
		4183	836.6	0.5	21.5
		4233	846.6	0.5	21.5
WCDMA Band II	Subtest 1	9262	1852.4	0	21.0
		9400	1880.0	0	21.4
		9538	1907.6	0	21.2
	Subtest 2	9262	1852.4	0	21.1
		9400	1880.0	0	21.3
		9538	1907.6	0	21.3
	Subtest 3	9262	1852.4	0.5	21.2
		9400	1880.0	0.5	21.4
		9538	1907.6	0.5	21.2
	Subtest 4	9262	1852.4	0.5	21.2
		9400	1880.0	0.5	21.4
		9538	1907.6	0.5	21.2

8.4. UMTS HSUPA

TEST PROCEDURE

The following summary of these settings are illustrated below: (ETSI TS 134.121-1 Table C.11.1)

	Mode	Rel6 HSUPA	Rel6 HSUPA	Rel6 HSUPA	Rel6 HSUPA	Rel6 HSUPA
	Subtest	1	2	3	4	5
WCDMA General Settings	Loopback Mode	Test Mode 1				
	P-CPICH (dB)	-10				
	P-CCPCH (dB)	-12				
	SCH (dB)	-12				
	PICH(dB)	-15				
	DPCH (dB)	-9				
	HS-SCCH 1 (dB)	-8				
	HS-PDSCH (dB)	-3				
	Rel99 RMC	12.2kbps RMC				
	HSDPA FRC	H-Set1				
	HSUPA Test	HSUPA Loopback				
	Power Control Algorithm	Algorithm2				
	Bc	11/15	6/15	15/15	2/15	15/15
	Bd	15/15	15/15	9/15	15/15	15/15
	Bec	209/225	12/15	30/15	2/15	5/15
	β_c/β_d	11/15	6/15	15/9	2/15	15/15
	Bhs	22/15	12/15	30/15	4/15	30/15
β_{ed} (note1)	1309/225	94/75	47/15	56/75	134/15	
MPR	0	2	1	2	0	
HSDPA Specific Settings	DACK	8				
	DNAK	8				
	DCQI	8				
	Ack-Nack repetition factor	3				
	CQI Feedback (Table 5.2B.4)	4ms				
	CQI Repetition Factor (Table 5.2B.4)	2				
	$A_{hs} = \beta_{hs}/\beta_c$	30/15				
HSUPA Specific Settings	D E-DPCCH	6	8	8	5	7
	DHARQ	0	0	0	0	0
	AG Index	20	12	15	17	21
	Reference E-TFCIs	5	5	2	5	5
	ETFCI (from 34.121 Table C.11.1.3)	75	67	92	71	81
	Associated Max UL Data Rate kbps	242.1	174.9	482.8	205.8	308.9
	Reference E_TFCIs	E-TFCI 11 E-TFCI PO 4 E-TFCI 67 E-TFCI PO 18 E-TFCI 71 E-TFCI PO 23 E-TFCI 75 E-TFCI PO 26 E-TFCI 81 E-TFCI PO 27		E-TFCI 11 E-TFCI PO 4 E-TFCI 92 E-TFCI PO 18		E-TFCI 11 E-TFCI PO 4 E-TFCI 67 E-TFCI PO 18 E-TFCI 71 E-TFCI PO 23 E-TFCI 75 E-TFCI PO 26 E-TFCI 81 E-TFCI PO 27

Note1: β_{ed} cannot be set directly, it is set by Absolute Grant Value.

8.4.1. UMTS HSUPA OUTPUT POWER RESULT

Band	Mode	UL Ch No.	Freq. (MHz)	MPR	Avg Pwr (dBm)
WCDMA Band V	Subtest 1	4132	826.4	0	21.8
		4183	836.6	0	22.0
		4233	846.6	0	21.9
	Subtest 2	4132	826.4	2	20.8
		4183	836.6	2	20.9
		4233	846.6	2	21.0
	Subtest 3	4132	826.4	1	20.1
		4183	836.6	1	20.8
		4233	846.6	1	21.1
	Subtest 4	4132	826.4	2	20.9
		4183	836.6	2	21.0
		4233	846.6	2	21.0
	Subtest 5	4132	826.4	0	22.2
		4183	836.6	0	22.1
		4233	846.6	0	22.0
WCDMA Band II	Subtest 1	9262	1852.4	0	20.5
		9400	1880.0	0	21.1
		9538	1907.6	0	21.1
	Subtest 2	9262	1852.4	2	20.0
		9400	1880.0	2	20.5
		9538	1907.6	2	20.3
	Subtest 3	9262	1852.4	1	20.8
		9400	1880.0	1	21.2
		9538	1907.6	1	20.9
	Subtest 4	9262	1852.4	2	20.2
		9400	1880.0	2	20.5
		9538	1907.6	2	20.5
	Subtest 5	9262	1852.4	0	21.1
		9400	1880.0	0	21.3
		9538	1907.6	0	21.2

DC-HSDPA

The following tests were completed according to procedures in section 7.3.13 of 3GPP TS34.108 v9.5.0. A summary of these settings are illustrated below:

Downlink Physical Channels are set as per 3GPP TS34.121-1 v9.0.0 E.5.0

Table E.5.0: Levels for HSDPA connection setup

Parameter During Connection setup	Unit	Value
P-CPICH_Ec/Ior	dB	-10
P-CCPCH and SCH_Ec/Ior	dB	-12
PICH_Ec/Ior	dB	-15
HS-PDSCH	dB	off
HS-SCCH_1	dB	off
DPCH_Ec/Ior	dB	-5
OCNS_Ec/Ior	dB	-3.1

Call is set up as per 3GPP TS34.108 v9.5.0 sub clause 7.3.13

The configurations of the fixed reference channels for HSDPA RF tests are described in 3GPP TS 34.121, annex C for FDD and 3GPP TS 34.122.

Table C.8.1.12: Fixed Reference Channel H-Set 12

Parameter	Unit	Value
Nominal Avg. Inf. Bit Rate	kbps	60
Inter-TTI Distance	TTI's	1
Number of HARQ Processes	Processes	6
Information Bit Payload (N_{INF})	Bits	120
Number Code Blocks	Blocks	1
Binary Channel Bits Per TTI	Bits	960
Total Available SML's in UE	SML's	19200
Number of SML's per HARQ Proc.	SML's	3200
Coding Rate		0.15
Number of Physical Channel Codes	Codes	1
Modulation		QPSK
Note 1: The RMC is intended to be used for DC-HSDPA mode and both cells shall transmit with identical parameters as listed in the table. Note 2: Maximum number of transmission is limited to 1, i.e., retransmission is not allowed. The redundancy and constellation version 0 shall be used.		

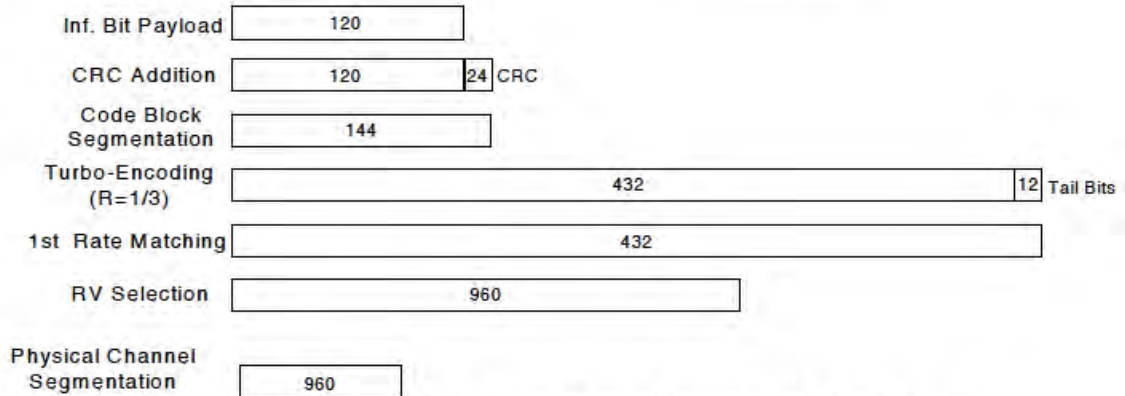

Figure C.8.19: Coding rate for Fixed reference Channel H-Set 12 (QPSK)

The following 4 Sub-tests for HSDPA were completed according to Release 8 procedures in section 5.2 of 3GPP TS34.121. A summary of subtest settings are illustrated below:

	Mode	HSDPA	HSDPA	HSDPA	HSDPA
	Subtest	1	2	3	4
WCDMA General Settings	Loopback Mode	Test Mode 1			
	Rel99 RMC	12.2kbps RMC			
	HSDPA FRC	H-Set 1			
	Power Control Algorithm	Algorithm2			
	β_c	2/15	11/15	15/15	15/15
	β_d	15/15	15/15	8/15	4/15
	β_d (SF)	64			
	β_c/β_d	2/15	12/15	15/8	15/4
	β_{hs}	4/15	24/15	30/15	30/15
MPR (dB)	0	0	0.5	0.5	
HSDPA Specific Settings	DACK	8			
	DNAK	8			
	DCQI	8			
	Ack-Nack Repetition factor	3			
	CQI Feedback	4ms			
	CQI Repetition Factor	2			
	$A_{hs} = \beta_{hs} / \beta_c$	30/15			

Up commands are set continuously to set the UE to Max power.

Measured Results

Band	Mode	UL Ch No.	Freq. (MHz)	MPR	Avg Pwr (dBm)
WCDMA Band V	Subtest 1	4132	826.4	0	22.1
		4183	836.6	0	22.2
		4233	846.6	0	22.2
	Subtest 2	4132	826.4	0	22.2
		4183	836.6	0	22.1
		4233	846.6	0	22.0
	Subtest 3	4132	826.4	0.5	21.5
		4183	836.6	0.5	21.5
		4233	846.6	0.5	21.5
	Subtest 4	4132	826.4	0.5	21.5
		4183	836.6	0.5	21.5
		4233	846.6	0.5	21.5
WCDMA Band II	Subtest 1	9262	1852.4	0	21.1
		9400	1880.0	0	21.3
		9538	1907.6	0	21.3
	Subtest 2	9262	1852.4	0	21.1
		9400	1880.0	0	21.3
		9538	1907.6	0	21.3
	Subtest 3	9262	1852.4	0.5	20.7
		9400	1880.0	0.5	20.8
		9538	1907.6	0.5	20.8
	Subtest 4	9262	1852.4	0.5	20.7
		9400	1880.0	0.5	20.8
		9538	1907.6	0.5	20.8

8.5. LTE OUTPUT VERIFICATION

8.5.1. LTE OUTPUT RESULT

Band	BW (MHz)	Mode	RB Allocation	RB offset	Target MPR	Meas. MPR	Avg Pwr (dBm)		
							829 MHz	836.5 MHz	844 MHz
LTE Band 5	10	QPSK	1	0	0	0	22.8	23.0	22.7
			1	25	0	0	22.8	22.9	22.6
			1	49	0	0	22.5	22.8	22.8
			25	0	1	1	22.0	22.0	21.9
			25	12	1	1	21.8	21.8	21.8
			25	25	1	1	21.9	21.8	21.8
		16QAM	50	0	1	1	22.0	21.9	21.8
			1	0	1	1	22.0	21.7	22.0
			1	25	1	1	22.0	21.8	22.0
			1	49	1	1	22.0	21.7	22.0
			25	0	2	2	21.0	21.0	21.0
			25	12	2	2	21.0	20.9	20.9
			25	25	2	2	20.8	20.9	20.9
			50	0	2	2	21.0	21.0	20.9
Band	BW (MHz)	Mode	RB Allocation	RB offset	Target MPR	Meas. MPR	Avg Pwr (dBm)		
							826.5 MHz	836.5 MHz	846.5 MHz
LTE Band 5	5	QPSK	1	0	0	0	22.8	22.8	22.8
			1	12	0	0	22.8	23.0	23.0
			1	24	0	0	22.8	22.8	22.8
			12	0	1	1	21.8	21.9	21.8
			12	6	1	1	21.9	21.9	21.9
			12	11	1	1	21.9	21.9	22.0
		16QAM	25	0	1	1	21.9	21.9	22.0
			1	0	1	1	21.8	21.8	21.9
			1	12	1	1	21.9	21.8	22.0
			1	24	1	1	21.8	21.8	21.9
			12	0	2	2	21.0	21.0	20.9
			12	6	2	2	21.0	21.0	20.8
			12	11	2	2	21.0	21.0	21.0
			25	0	2	2	21.0	20.9	21.0
Band	BW (MHz)	Mode	RB Allocation	RB offset	Target MPR	Meas. MPR	Avg Pwr (dBm)		
							825.5 MHz	836.5 MHz	847.5 MHz
LTE Band 5	3	QPSK	1	0	0	0	22.7	22.9	23.0
			1	7	0	0	22.8	22.9	22.9
			1	14	0	0	22.7	23.0	22.7
			8	0	1	1	21.8	21.9	22.0
			8	4	1	1	21.7	21.9	21.9
			8	7	1	1	21.7	21.8	21.8
		16QAM	15	0	1	1	21.8	21.9	21.9
			1	0	1	1	22.0	22.0	22.0
			1	7	1	1	22.0	22.0	22.0
			1	14	1	1	22.0	22.0	21.9
			8	0	2	2	20.9	20.9	21.0
			8	4	2	2	20.9	20.6	21.0
			8	7	2	2	20.8	20.7	20.9
			15	0	2	2	20.8	20.9	20.8

Band	BW (MHz)	Mode	RB Allocation	RB offset	Target MPR	Meas. MPR	Avg Pwr (dBm)		
							824.7 MHz	836.5 MHz	848.3 MHz
LTE Band 5	1.4	QPSK	1	0	0	0	22.8	23.0	22.8
			1	2	0	0	22.9	22.8	22.8
			1	5	0	0	22.7	22.8	22.7
			3	0	0	0	22.8	22.8	22.9
			3	1	0	0	22.8	22.8	22.8
			3	2	0	0	22.8	22.9	22.9
			6	0	1	1	21.7	21.8	21.7
		16QAM	1	0	1	1	22.0	22.0	21.8
			1	2	1	1	22.0	21.9	22.0
			1	5	1	1	22.0	22.0	22.0
			3	0	1	1	21.8	22.0	22.0
			3	1	1	1	21.8	21.9	21.9
			3	2	1	1	22.0	21.9	21.8
			6	0	2	2	21.0	21.0	20.9

9. PEAK TO AVERAGE RATIO

Test Procedure

Per KDB 971168 D01 Power Meas License Digital Systems v02r01

Test Spec

In addition, when the transmitter power is measured in terms of average value, the peak-to-average ratio of the power shall not exceed 13 dB.

9.1. CONDUCTED PEAK TO AVERAGE RESULT

9.1.1. WCDMA

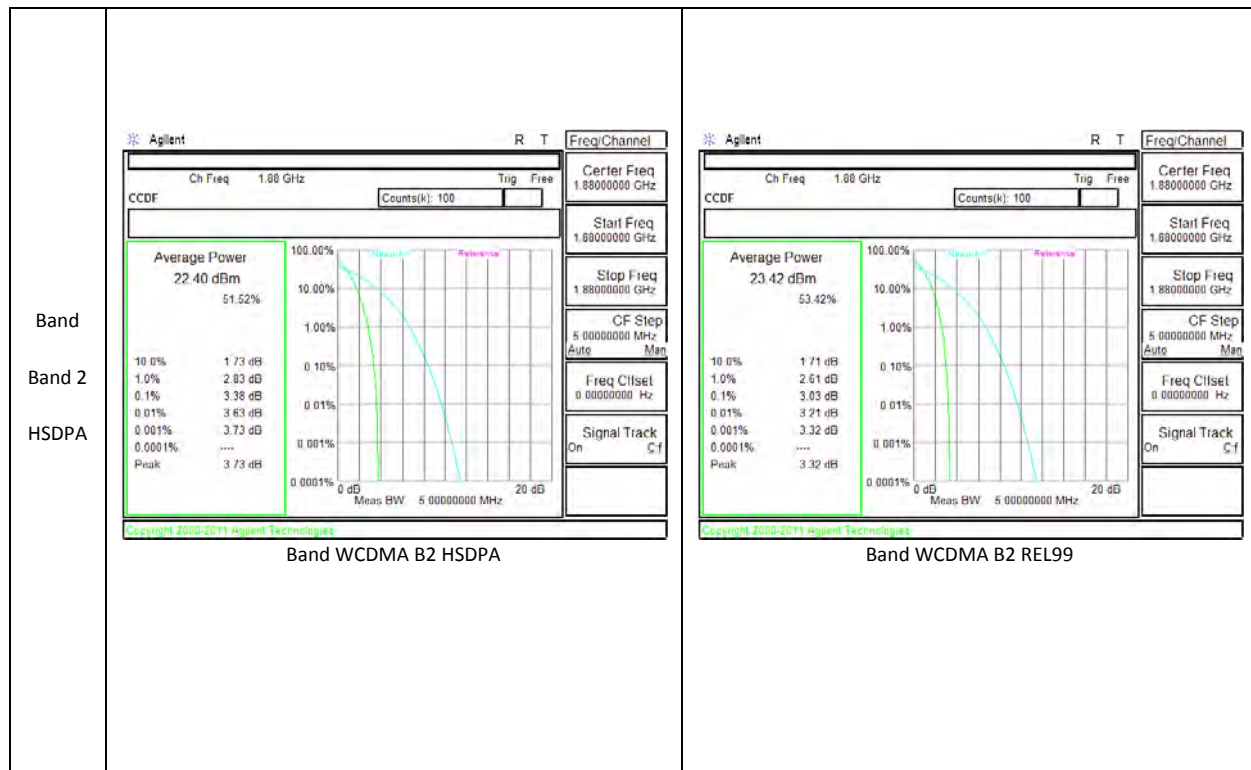

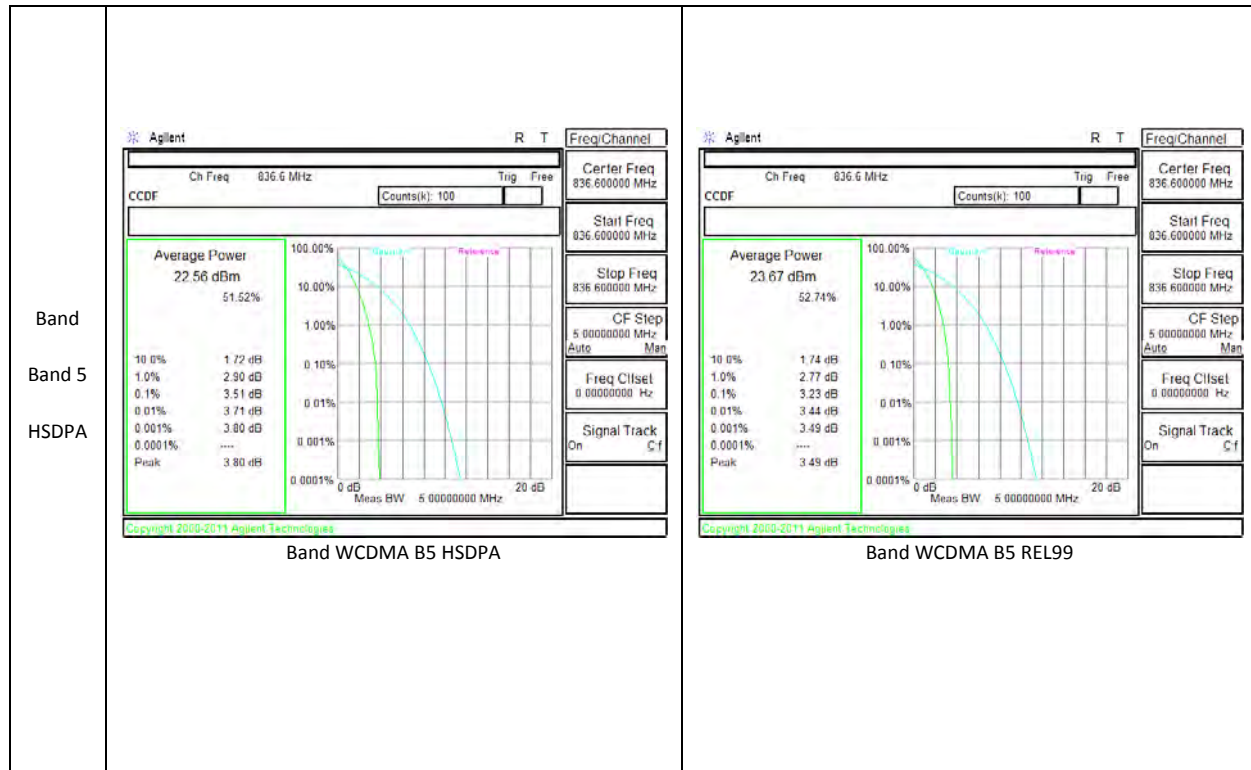

9.1.2. LTE Band 5

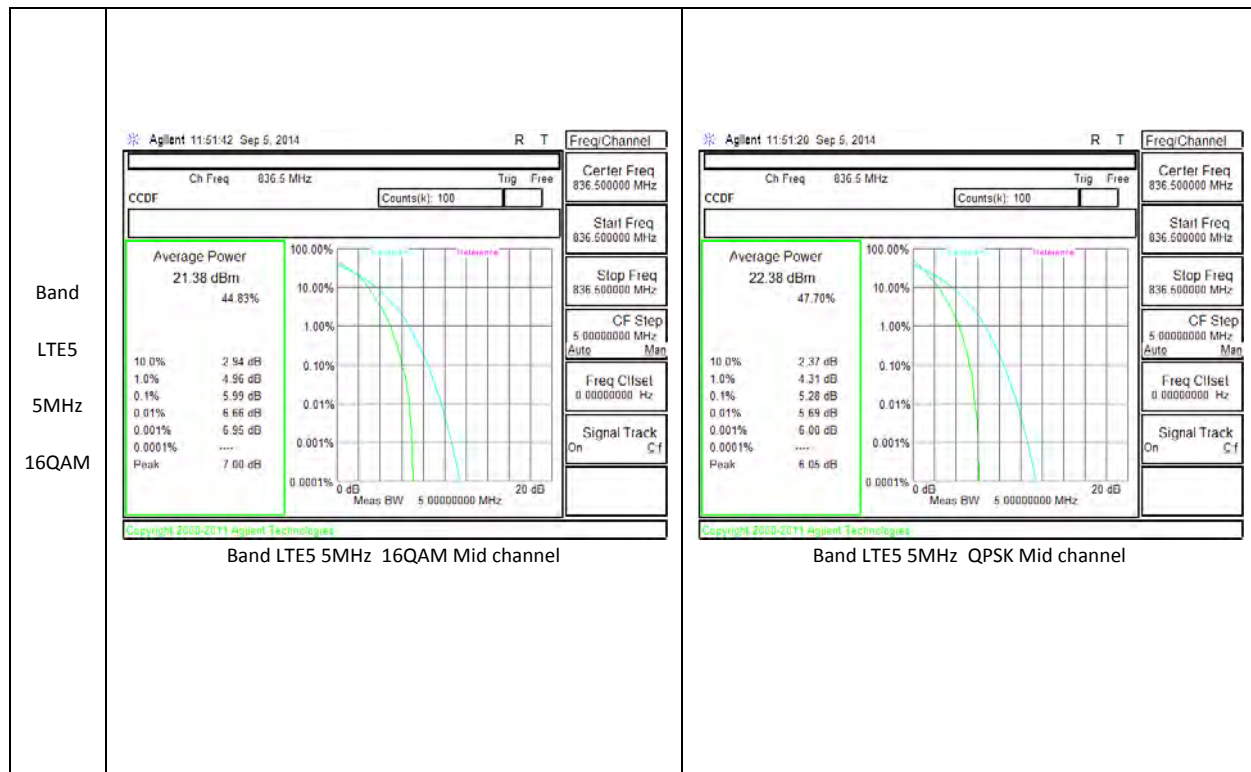
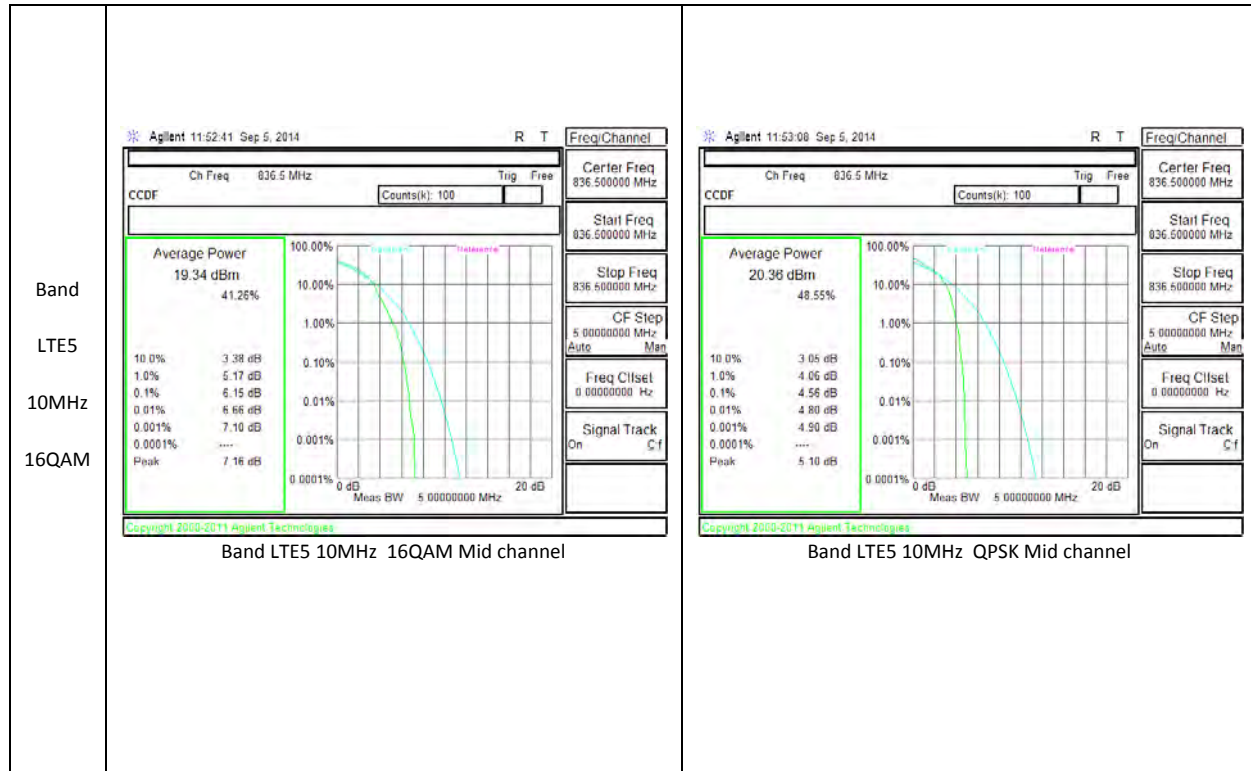

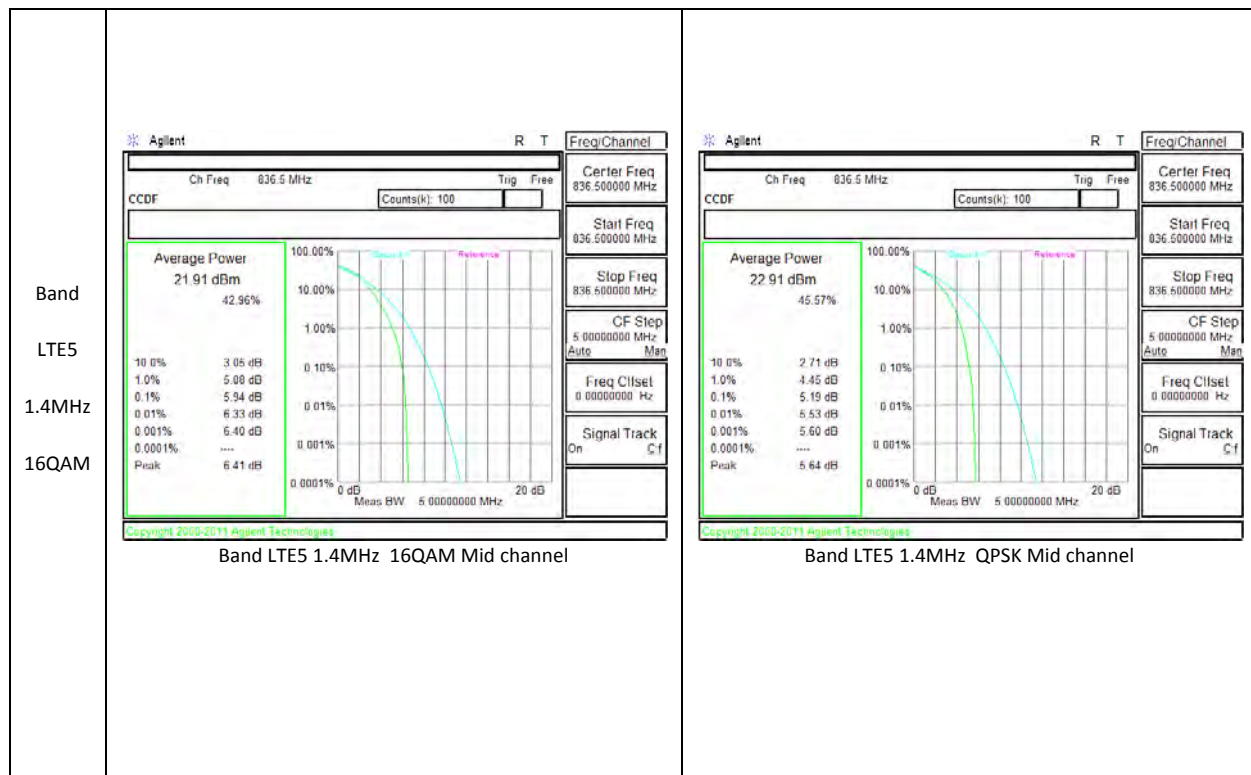
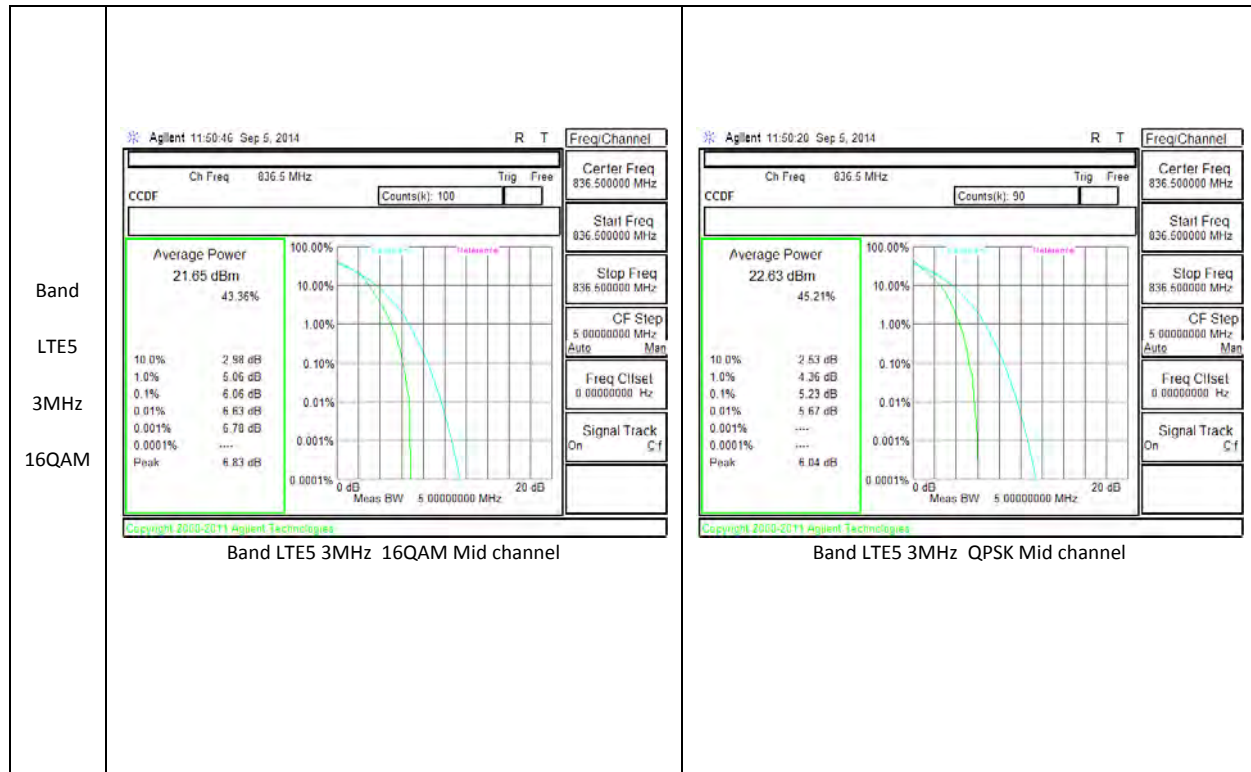

9.1.3. GSM

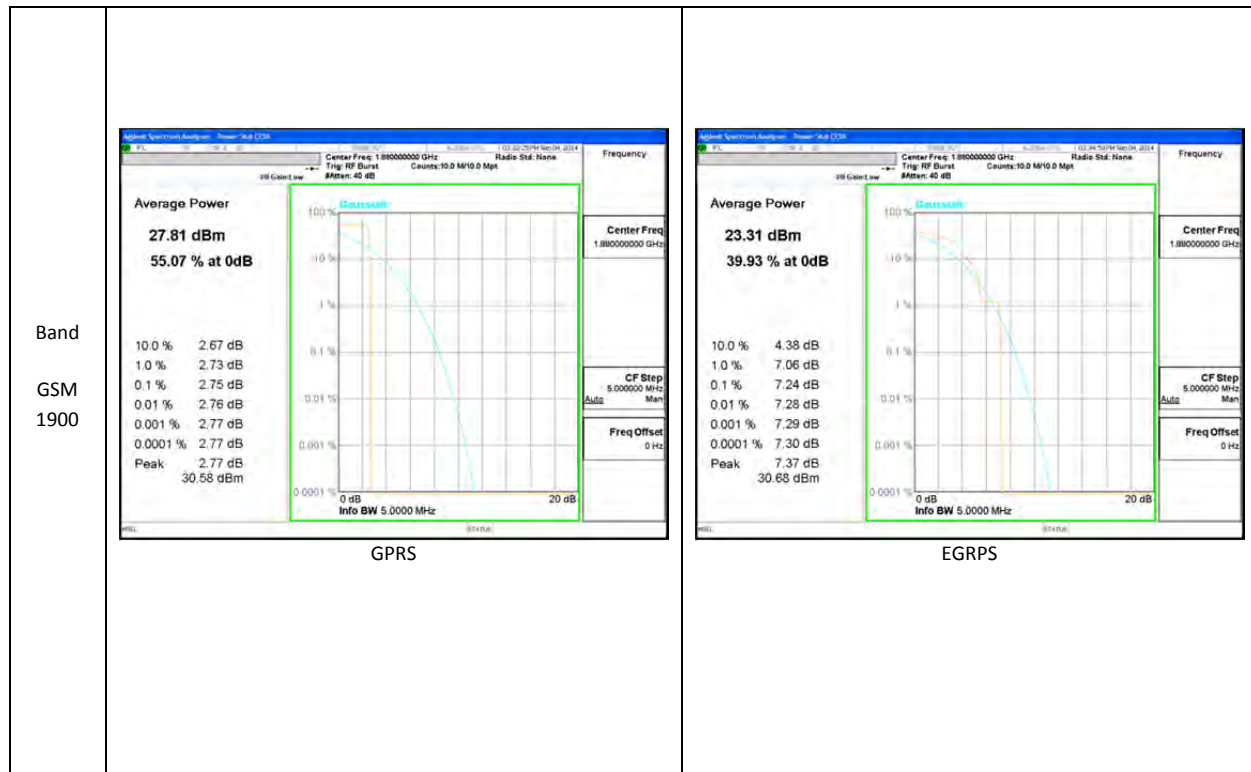
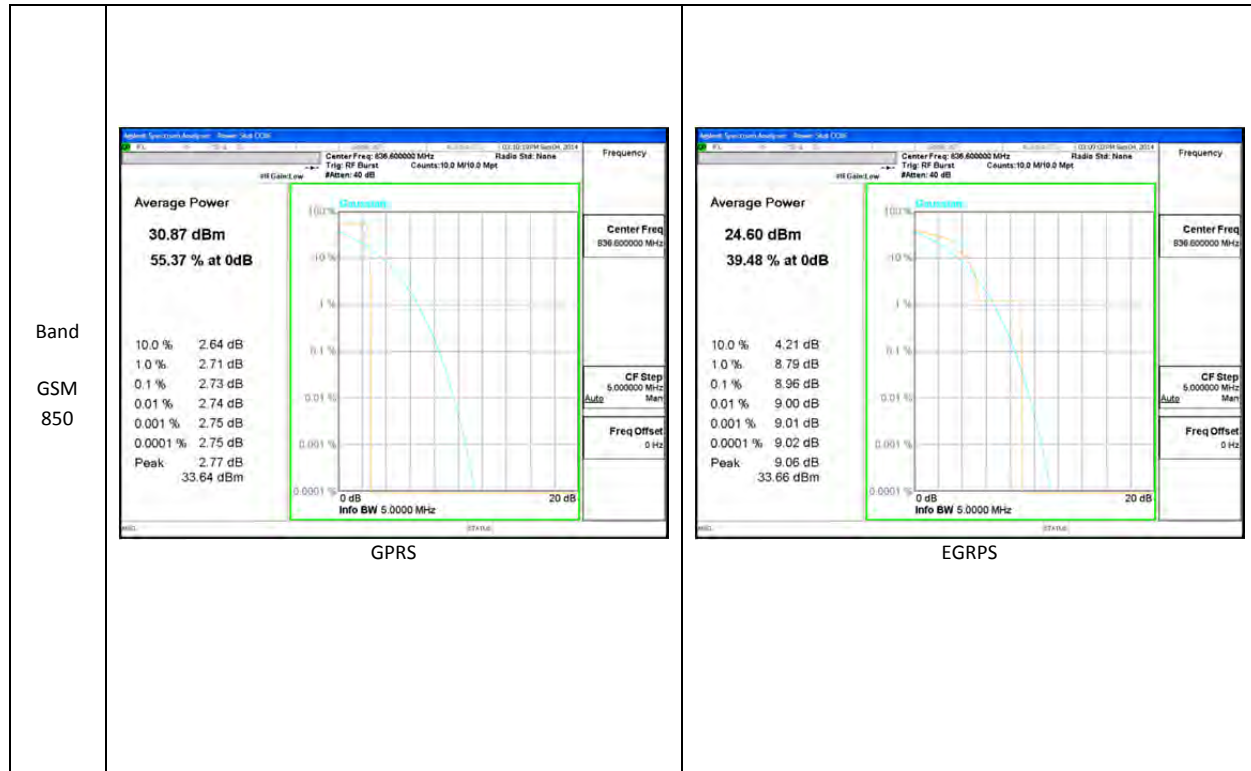

10. LIMITS AND CONDUCTED RESULTS

10.1. OCCUPIED BANDWIDTH

RULE PART(S)

FCC: §2.1049

IC: RSS-132, 4.5; RSS-133, 6.5

LIMITS

For reporting purposes only

TEST PROCEDURE

The transmitter output was connected to a calibrated coaxial cable and coupler, the other end of which was connected to a spectrum analyzer. The occupied bandwidth was measured with the spectrum analyzer at the low, middle and high channel in each band. The -26dB bandwidth was also measured and recorded.

(KDB 971168 D01 Power Meas License Digital Systems v02r01 - 06/07/2013)

10.1.1. OCCUPIED BANDWIDTH RESULTS

Band	Mode	Channel	f (MHz)	99% BW (KHz)	-26dB BW (KHz)
GSM850	GMSK	128	824.2		
		190	836.6		
		251	848.8		
	GPRS	128	824.2	242.52	321.7
		190	836.6	245.2	319.7
		251	848.8	246.27	315.9
	EGPRS	128	824.2	246.05	316.3
		190	836.6	241.85	312.9
		251	848.8	240.52	311.1
GSM1900	GMSK	512	1850.2		
		661	1880		
		810	1909.8		
	GPRS	512	1850.2	246.37	330.6
		661	1880	243.69	328.4
		810	1909.8	246.3	329.6
	EGPRS	512	1850.2	249.77	330.7
		661	1880	247.8	328.6
		810	1909.8	246.82	326.9

Band	Mode	Channel	f (MHz)	99% BW (MHz)	-26dB BW (MHz)
Band 5	REL99	4132	826.4	4.1704	4.604
		4183	836.6	4.168	4.621
		4233	846.6	4.139	4.603
	HSDPA	4132	826.4	4.158	4.58
		4183	836.6	4.154	4.608
		4233	846.6	4.152	4.604
	HSUPA	4132	826.4		
		4183	836.6		
		4233	846.6		
Band 2	REL99	9262	1852.4	4.149	4.607
		9400	1880	4.158	4.625
		9538	1907.6	4.168	4.635
	HSDPA	9262	1852.4	4.135	4.614
		9400	1880	4.163	4.609
		9538	1907.6	4.138	4.599
	HSUPA	9262	1852.4		
		9400	1880		
		9538	1907.6		

10.1.2. LTE OCCUPIED BANDWIDTH RESULTS

Band	BW(MHz)	Mode	RB/RB Size	f (MHz)	99% BW (MHz)	-26dB BW (MHz)
LTE5	10	QPSK	50/0	829	8.983	9.269
			50/0	836.5	8.883	9.146
			50/0	844	8.791	9.184
		16QAM	50/0	829	8.898	9.161
			50/0	836.5	8.76	9.338
			50/0	844	8.85	9.14

Band	BW(MHz)	Mode	RB/RB Size	f (MHz)	99% BW (MHz)	-26dB BW (MHz)
LTE5	5	QPSK	25/0	826.5	4.446	4.723
			25/0	836.5	4.409	4.563
			25/0	846.5	4.425	4.425
		16QAM	25/0	826.5	4.409	4.652
			25/0	836.5	4.472	4.634
			25/0	846.5	4.425	4.571

Band	BW(MHz)	Mode	RB/RB Size	f (MHz)	99% BW (MHz)	-26dB BW (MHz)
LTE5	3	QPSK	15/0	825.5	2.511	2.822
			15/0	836.5	2.656	2.834
			15/0	847.5	2.64	2.827
		16QAM	15/0	825.5	2.633	2.826
			15/0	836.5	2.687	2.779
			15/0	847.5	2.662	2.894

Band	BW(MHz)	Mode	RB/RB Size	f (MHz)	99% BW (KHz)	-26dB BW (KHz)
LTE5	1.4	QPSK	6/0	824.7	1.099	1.282
			6/0	836.5	1.082	1.268
			6/0	848.3	1.081	1.244
		16QAM	6/0	824.7	1.086	1.262
			6/0	836.5	1.081	1.261
			6/0	848.3	1.085	1.27

10.1.1. OCCUPIED BANDWIDTH PLOTS

OCCUPIED BANDWIDTH PLOTS

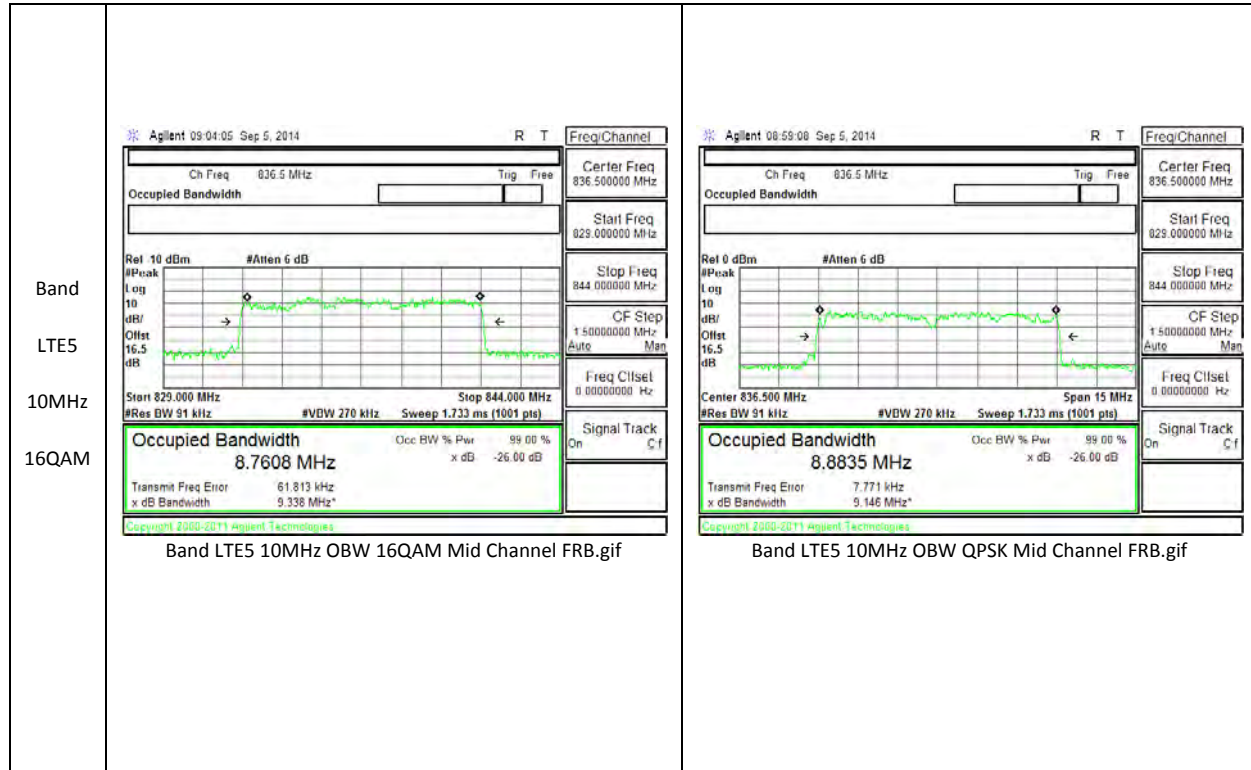

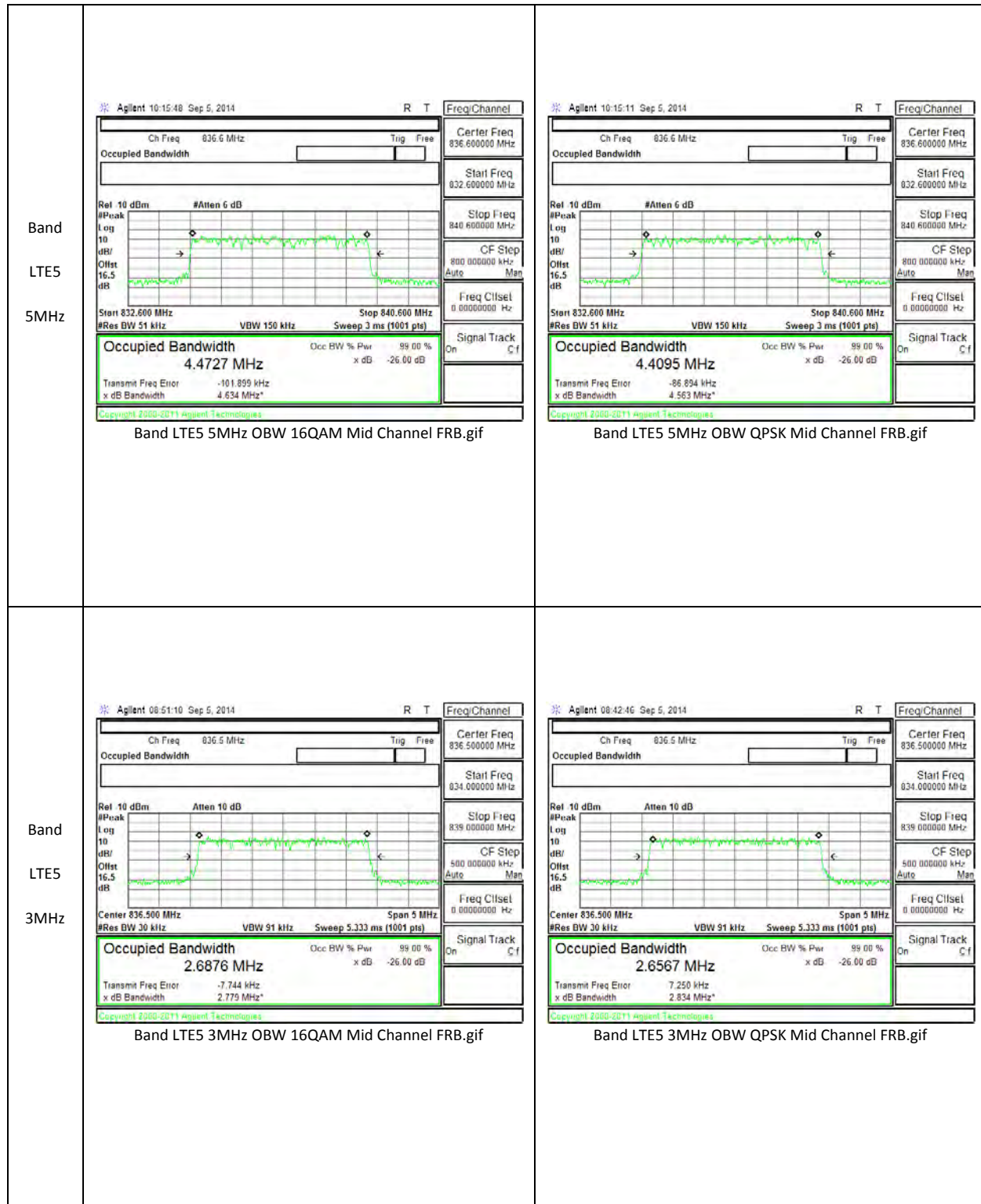

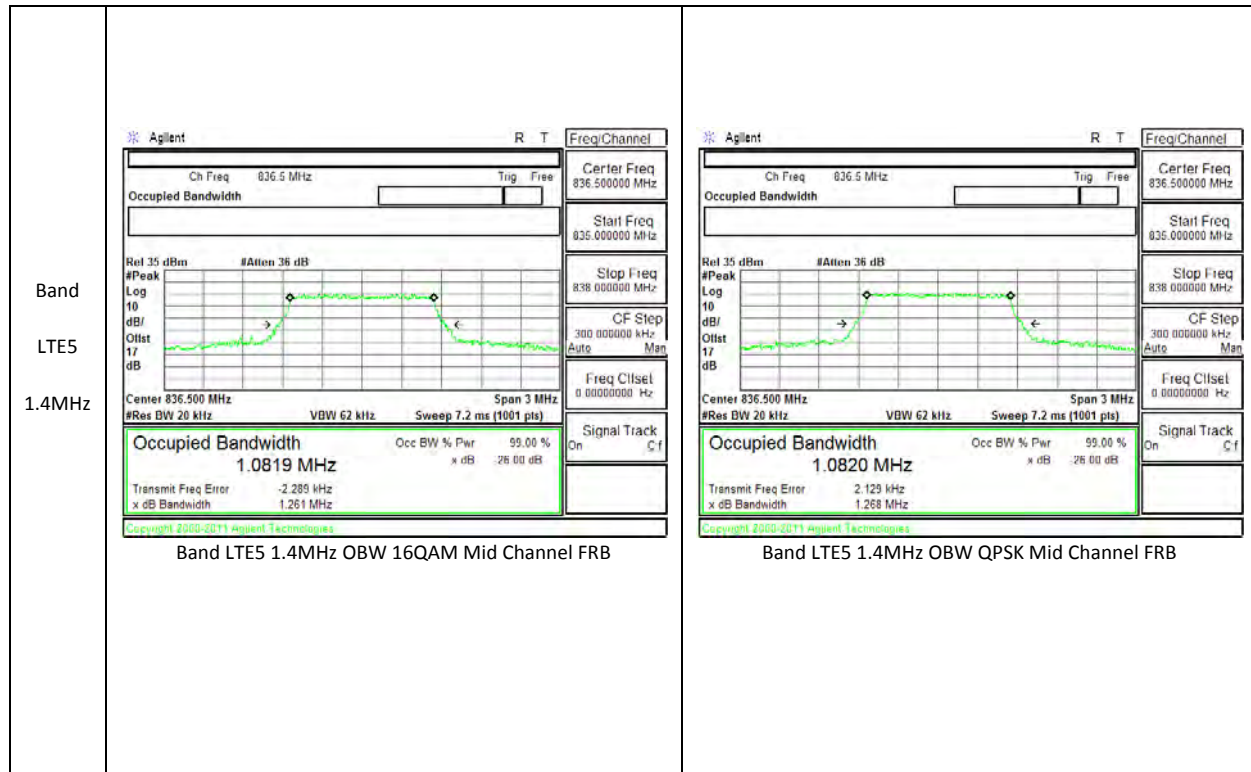

<p>Band Band 5 HSDPA</p>	<p>Agilent R T Freq/Channel</p> <p>Ch Freq 836.6 MHz Trig Free Center Freq 836.600000 MHz</p> <p>Occupied Bandwidth</p> <p>Start Freq 831.600000 MHz</p> <p>Stop Freq 841.600000 MHz</p> <p>CF Step 1.00000000 MHz</p> <p>Freq Clsset 0.00000000 Hz</p> <p>Signal Track On Cf</p> <p>Center 836.60 MHz Span 10 MHz</p> <p>Res BW 35 kHz VBW 120 kHz Sweep 6.333 ms (1001 pts)</p> <p>Occupied Bandwidth 4.1537 MHz</p> <p>Occ BW % Pwr 99.00 %</p> <p>Transmit Freq Error -13.320 kHz</p> <p>x dB Bandwidth 4.608 MHz</p> <p>Copyright 2002-2011 Agilent Technologies</p> <p>Band WCDMA B5 HSDPA OBW</p>	<p>Agilent R T Freq/Channel</p> <p>Ch Freq 836.6 MHz Trig Free Center Freq 836.600000 MHz</p> <p>Occupied Bandwidth</p> <p>Start Freq 831.600000 MHz</p> <p>Stop Freq 841.600000 MHz</p> <p>CF Step 1.00000000 MHz</p> <p>Freq Clsset 0.00000000 Hz</p> <p>Signal Track On Cf</p> <p>Center 836.60 MHz Span 10 MHz</p> <p>Res BW 35 kHz VBW 120 kHz Sweep 6.333 ms (1001 pts)</p> <p>Occupied Bandwidth 4.1681 MHz</p> <p>Occ BW % Pwr 99.00 %</p> <p>Transmit Freq Error 1.218 kHz</p> <p>x dB Bandwidth 4.621 MHz</p> <p>Copyright 2002-2011 Agilent Technologies</p> <p>Band WCDMA B5 REL99 OBW</p>
<p>Band GSM 1900 EGPRS</p>	<p>Agilent Spectrum Analyzer - Occupied BW</p> <p>Center Freq: 1.880000000 GHz Radio Std: None</p> <p>Ref Offset 16 dB Ref 40.00 dBm</p> <p>Occupied Bandwidth 247.80 kHz</p> <p>Total Power 36.0 dBm</p> <p>Transmit Freq Error 440 Hz</p> <p>x dB Bandwidth 328.6 kHz</p> <p>OBW Power 99.00 %</p> <p>x dB -26.00 dB</p> <p>Center Freq 1.88000000 GHz</p> <p>CF Step 100.000 kHz</p> <p>Center 1.88 GHz Span 1 MHz</p> <p>Res BW 24 kHz #VBW 75 kHz Sweep 1.667 ms</p> <p>Radio Device: BTS</p> <p>Band GSM1900 EGPRS OBW Mid channel</p>	<p>Agilent Spectrum Analyzer - Occupied BW</p> <p>Center Freq: 1.880000000 GHz Radio Std: None</p> <p>Ref Offset 16 dB Ref 40.00 dBm</p> <p>Occupied Bandwidth 243.69 kHz</p> <p>Total Power 38.0 dBm</p> <p>Transmit Freq Error 1.297 kHz</p> <p>x dB Bandwidth 328.4 kHz</p> <p>OBW Power 99.00 %</p> <p>x dB -26.00 dB</p> <p>Center Freq 1.88000000 GHz</p> <p>CF Step 100.000 kHz</p> <p>Center 1.88 GHz Span 1 MHz</p> <p>Res BW 24 kHz #VBW 75 kHz Sweep 1.667 ms</p> <p>Radio Device: BTS</p> <p>Band GSM1900 GPRS OBW Mid channel</p>



10.2. BAND EDGE EMISSIONS

RULE PART(S)

FCC: §22.359, §24.238, §27.53

LIMITS

The power of any emission outside of the authorized operating frequency ranges must be attenuated below the transmitting power (P) by a factor of at least $43 + 10 \log (P)$ dB.

TEST PROCEDURE

Per KDB 971168 D01 Power Meas License Digital Systems v02r01

The transmitter output was connected to an Agilent 8960 or a CMW500 Test Set and configured to operate at maximum power. The band edge emissions were measured at the required operating frequencies in each band on the Spectrum Analyzer.

MODES TESTED

GSM, WCDMA, and LTE Band 5

RESULTS

10.2.1. BAND EDGE PLOTS

WCDMA

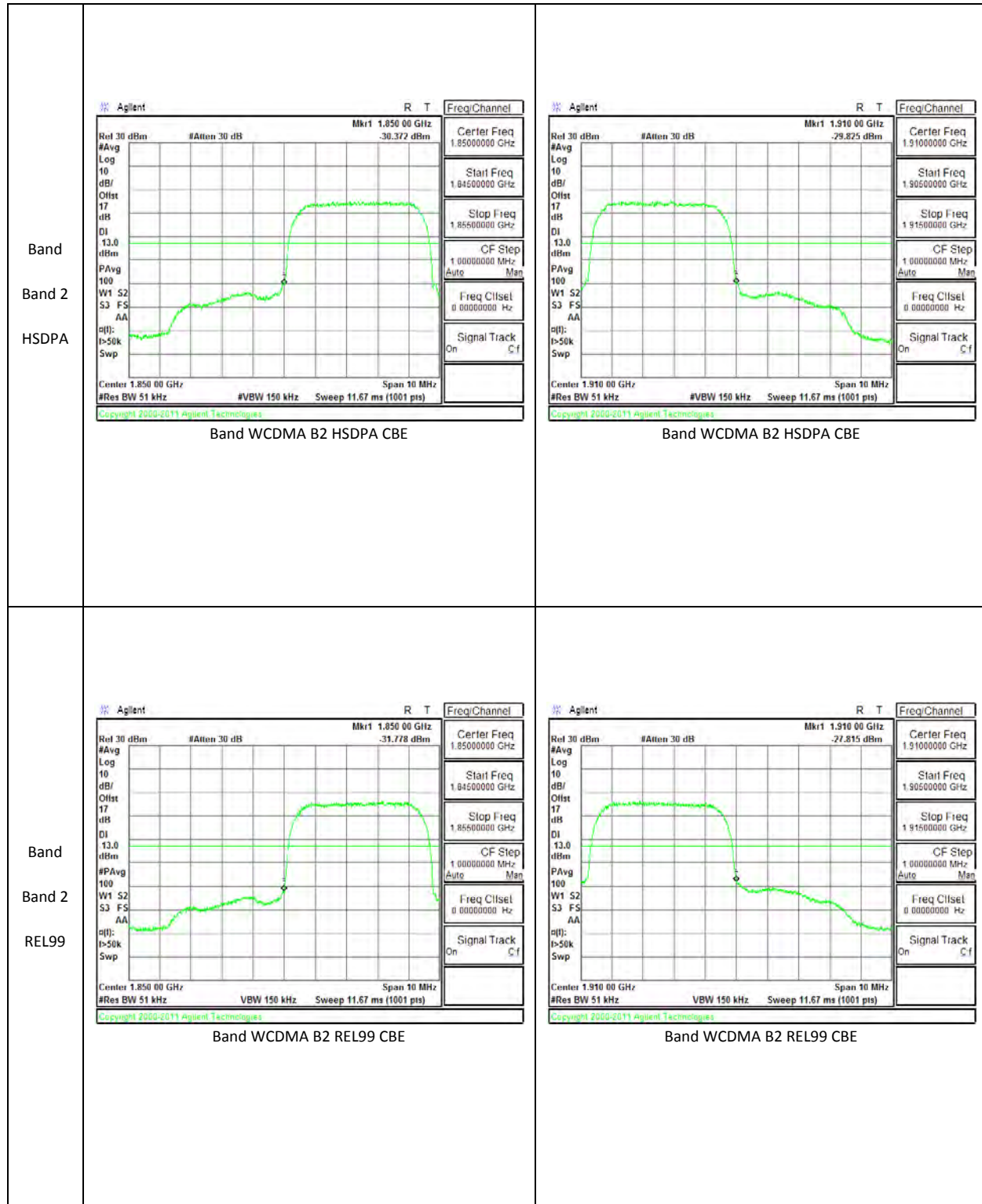

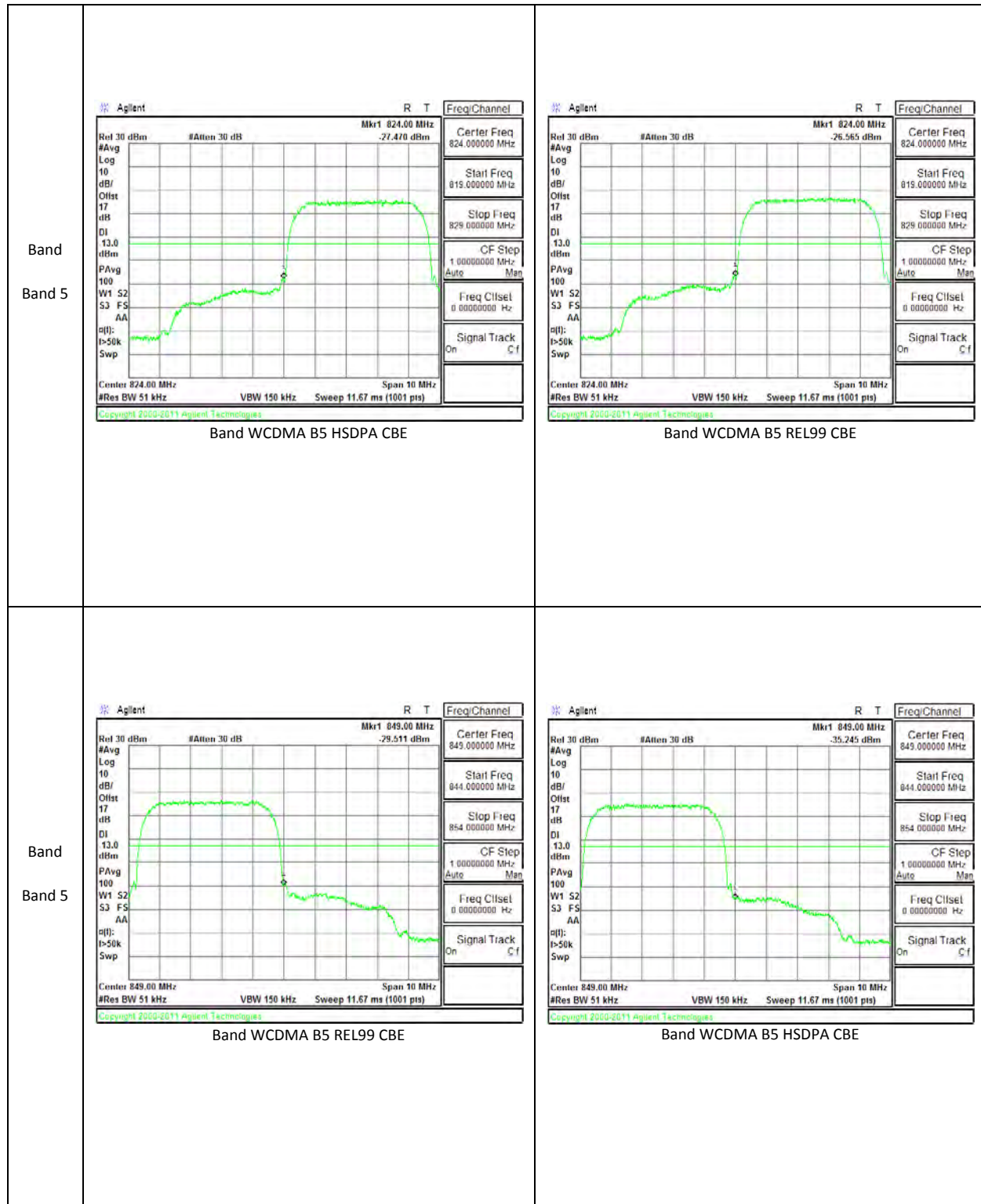

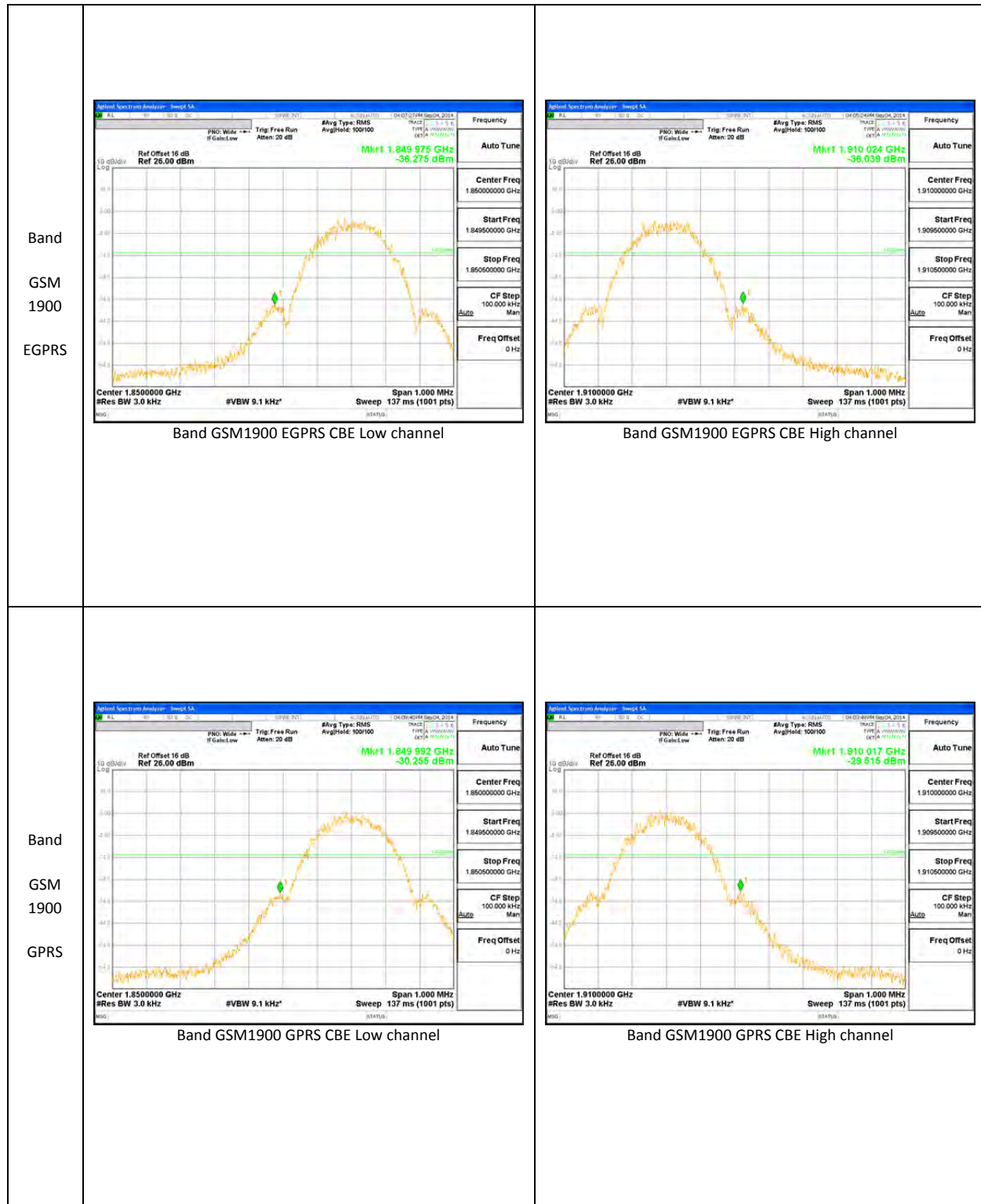

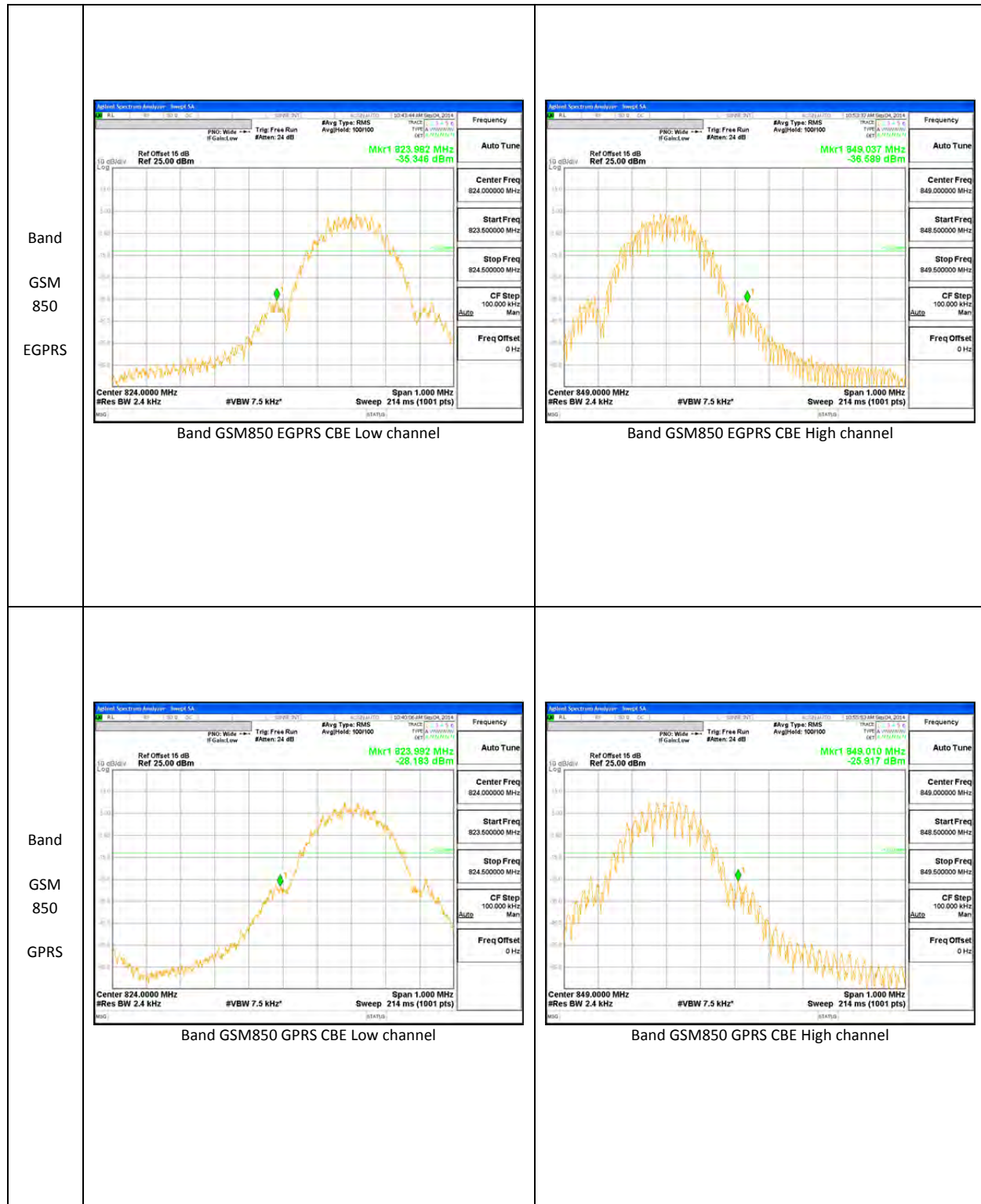

LTE Band 5

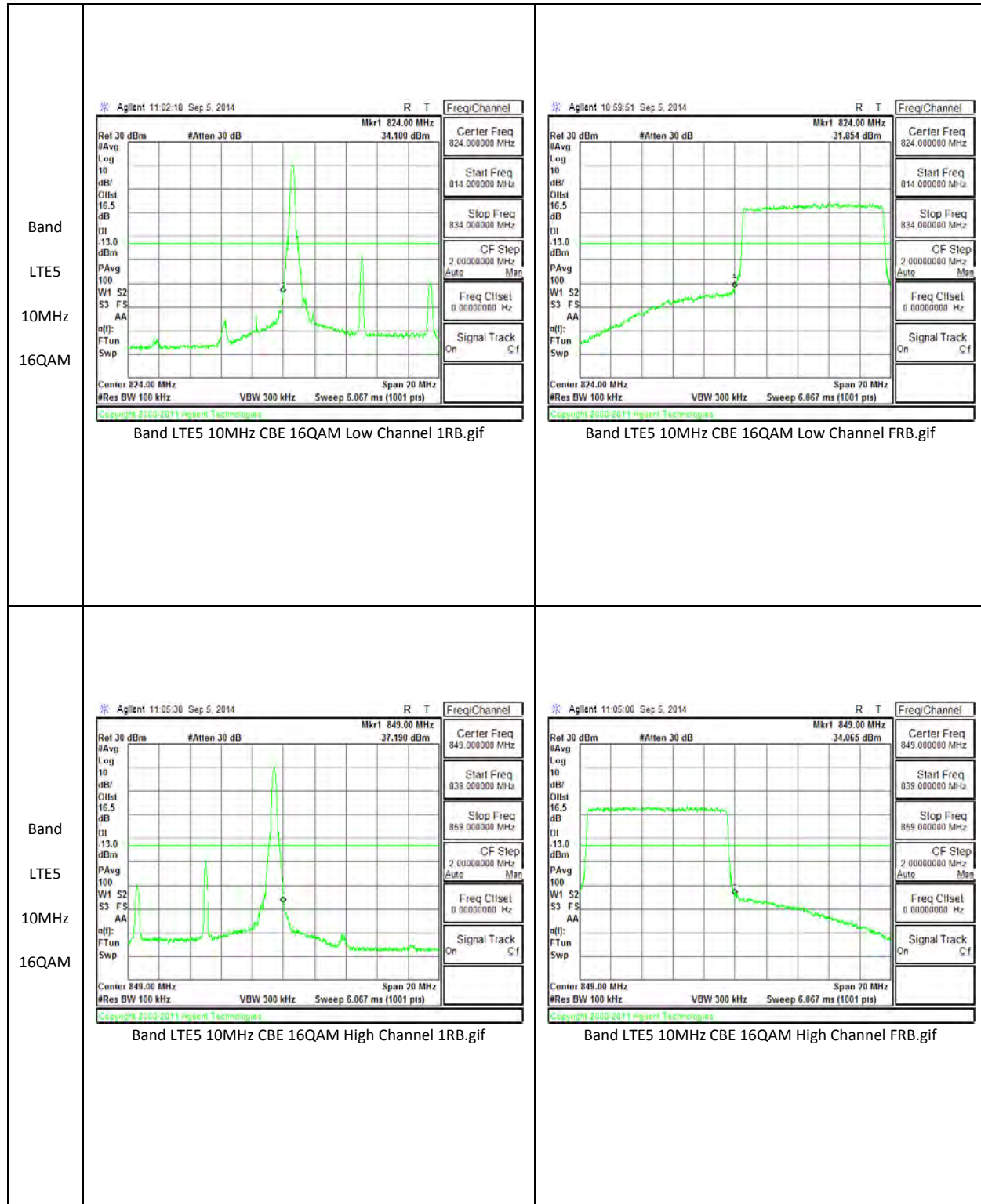

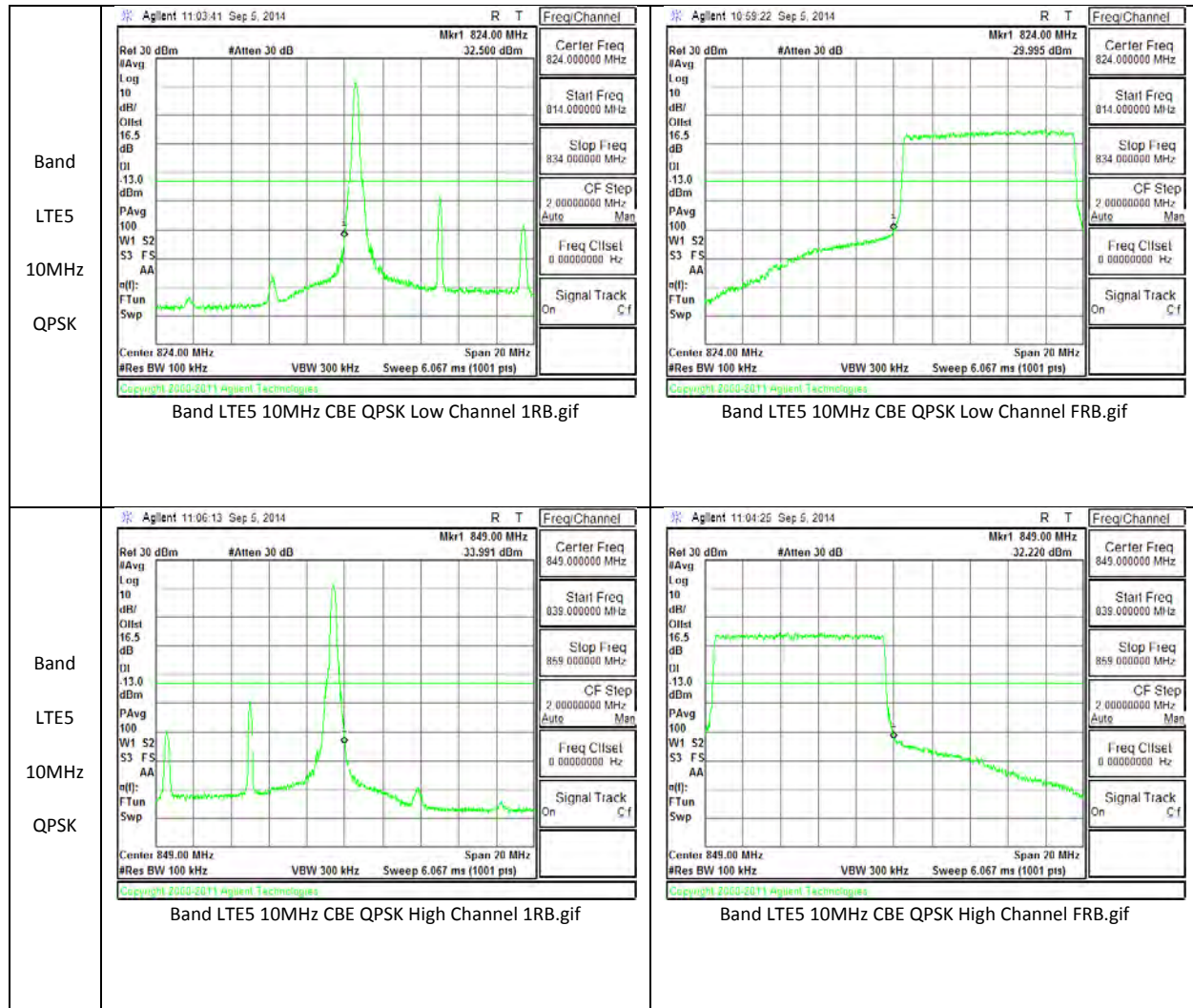

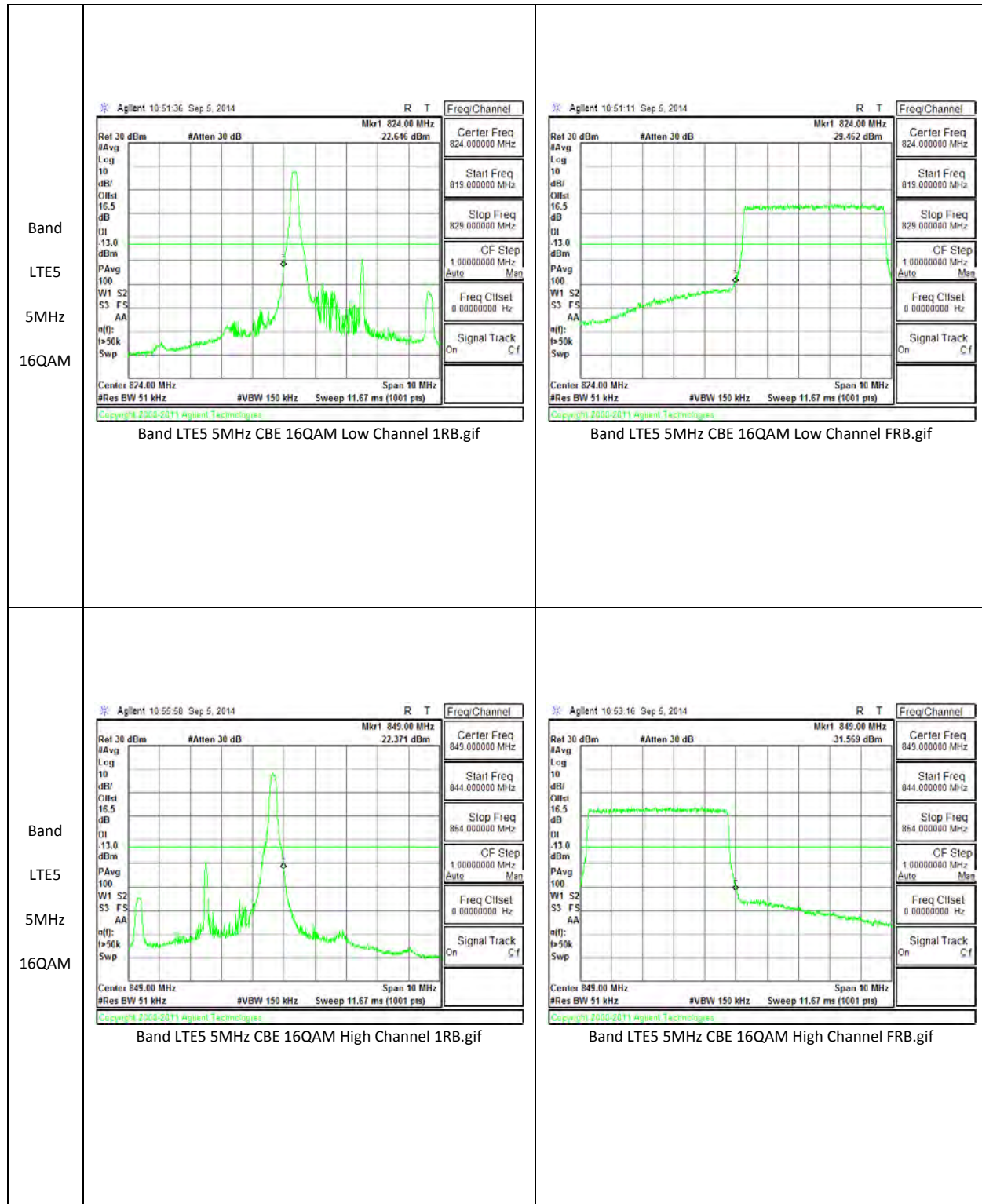

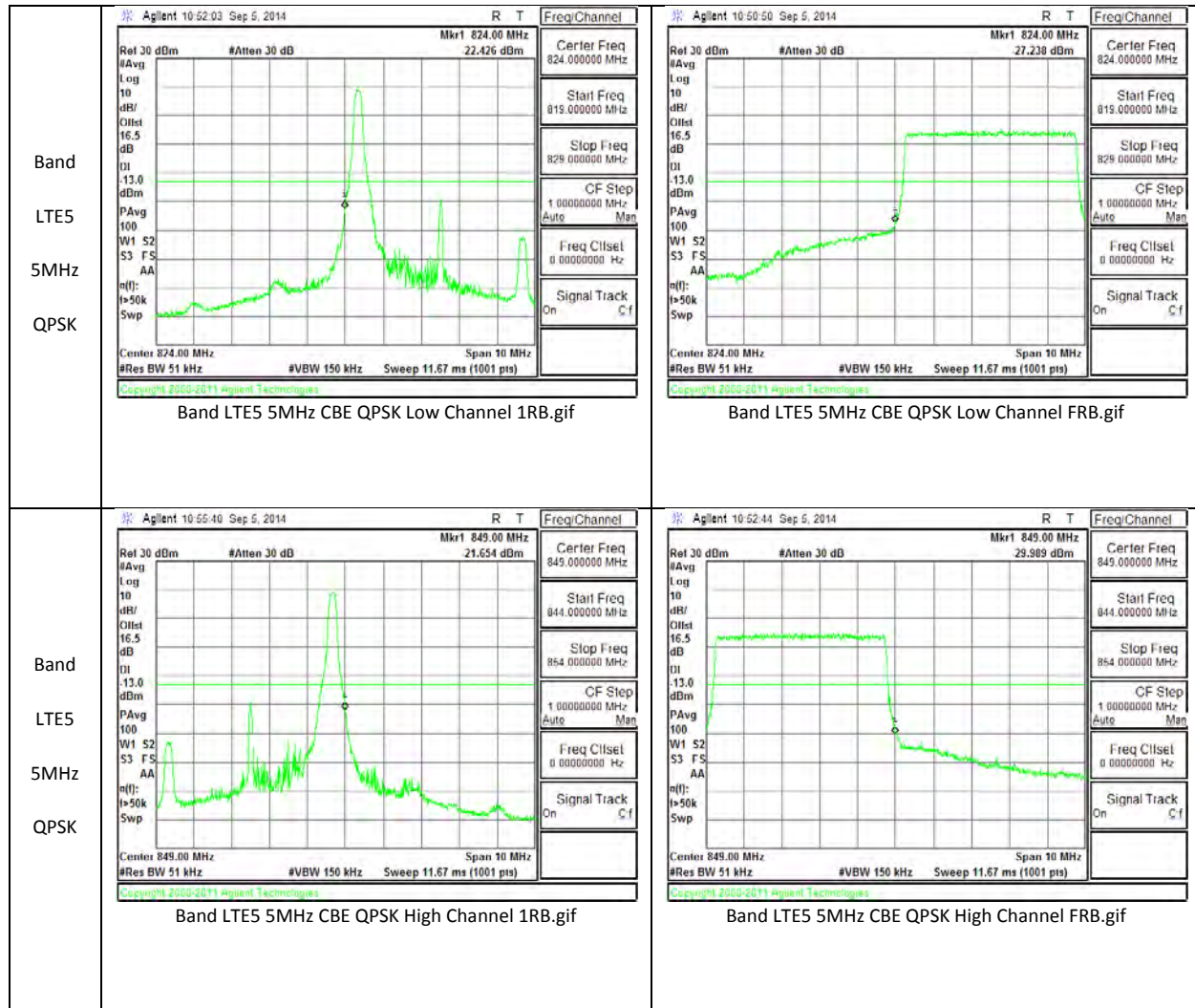

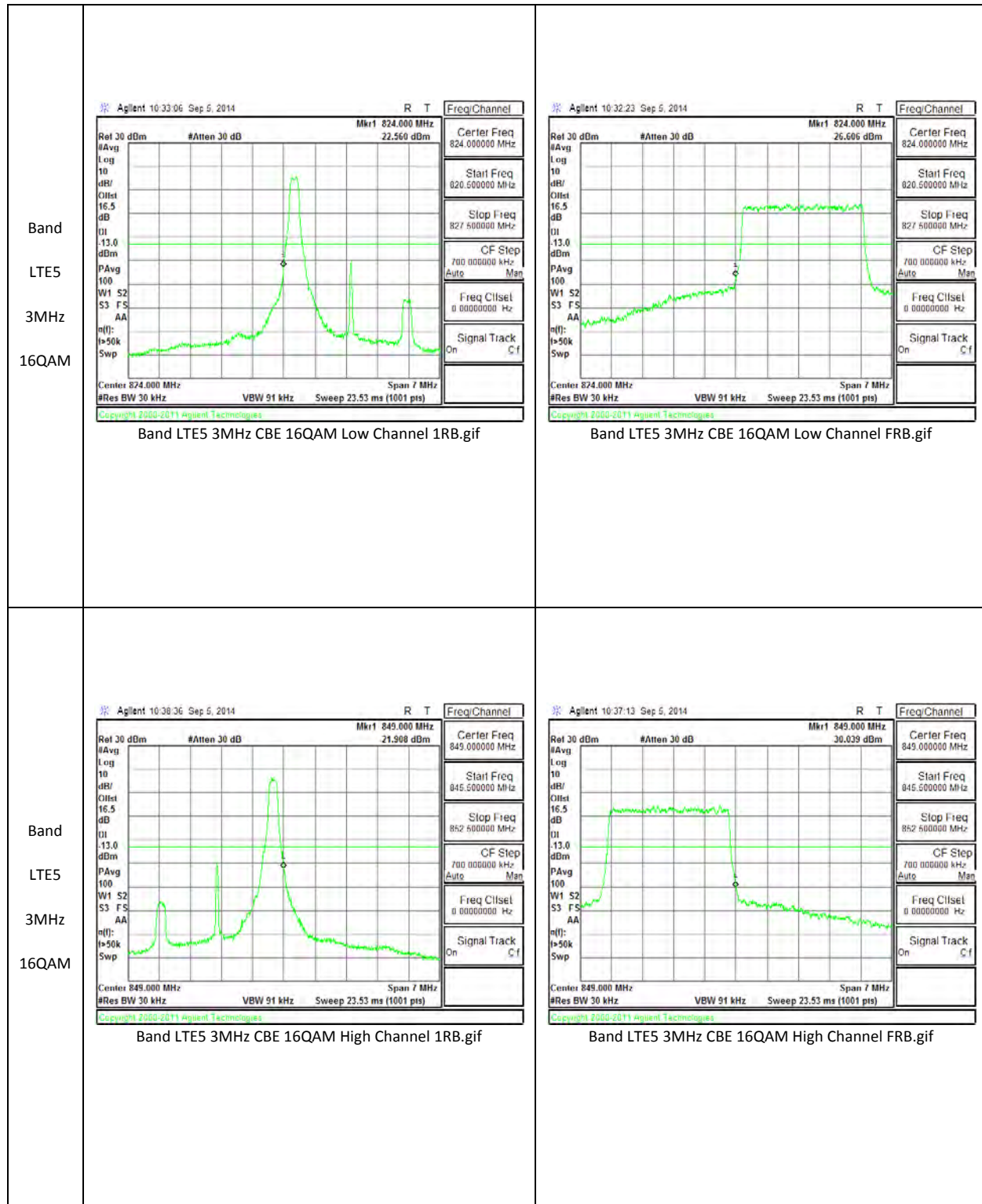

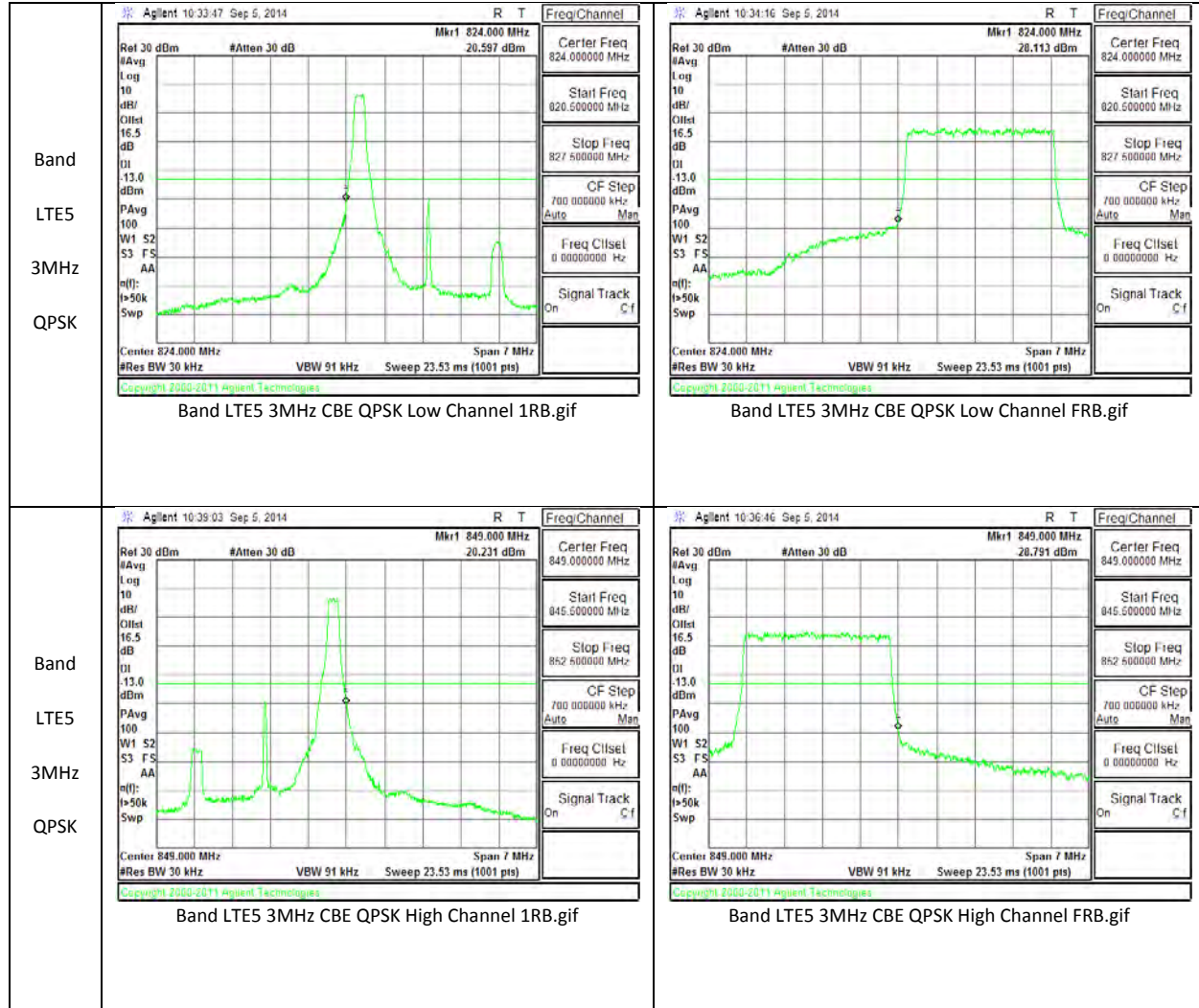

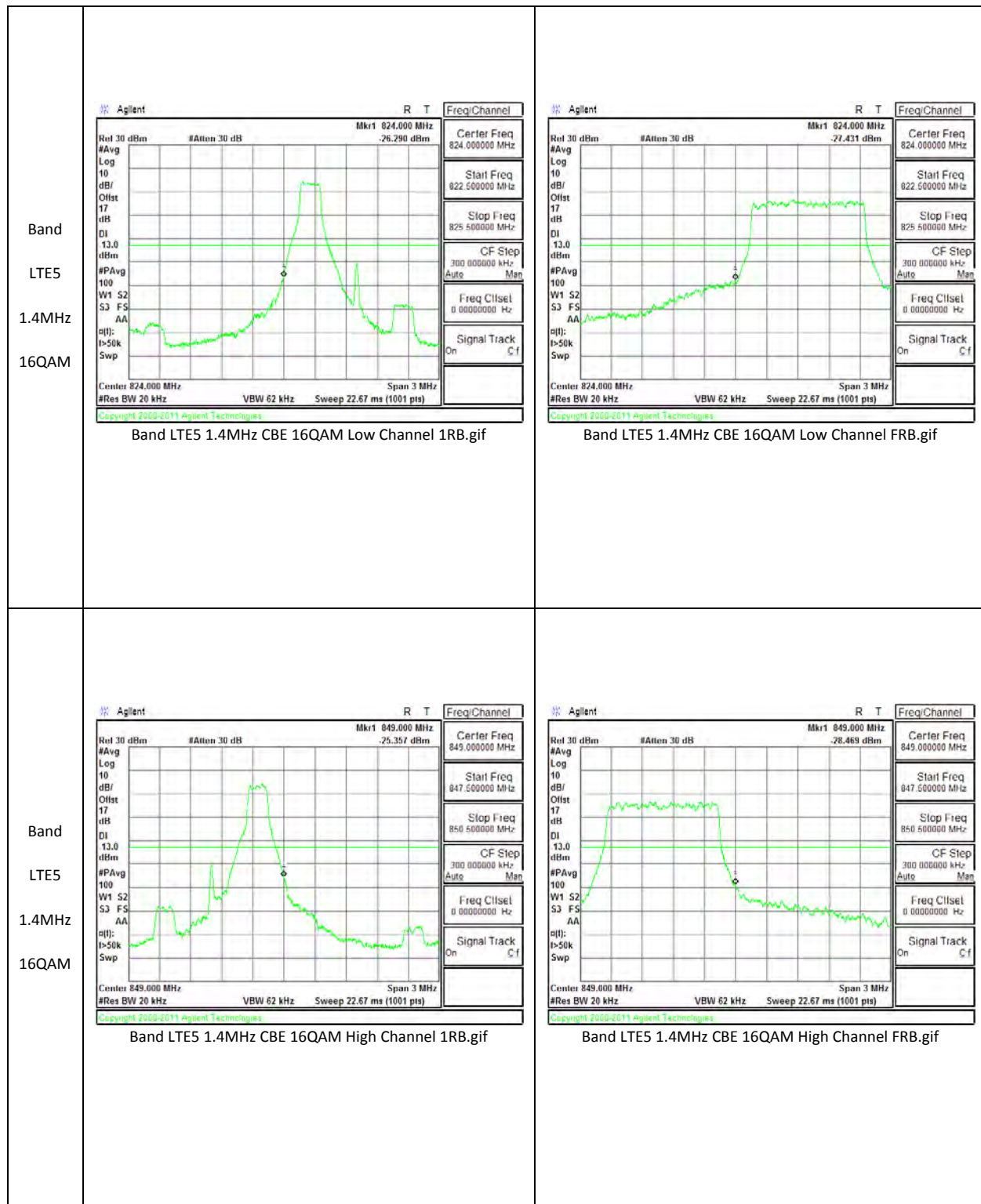

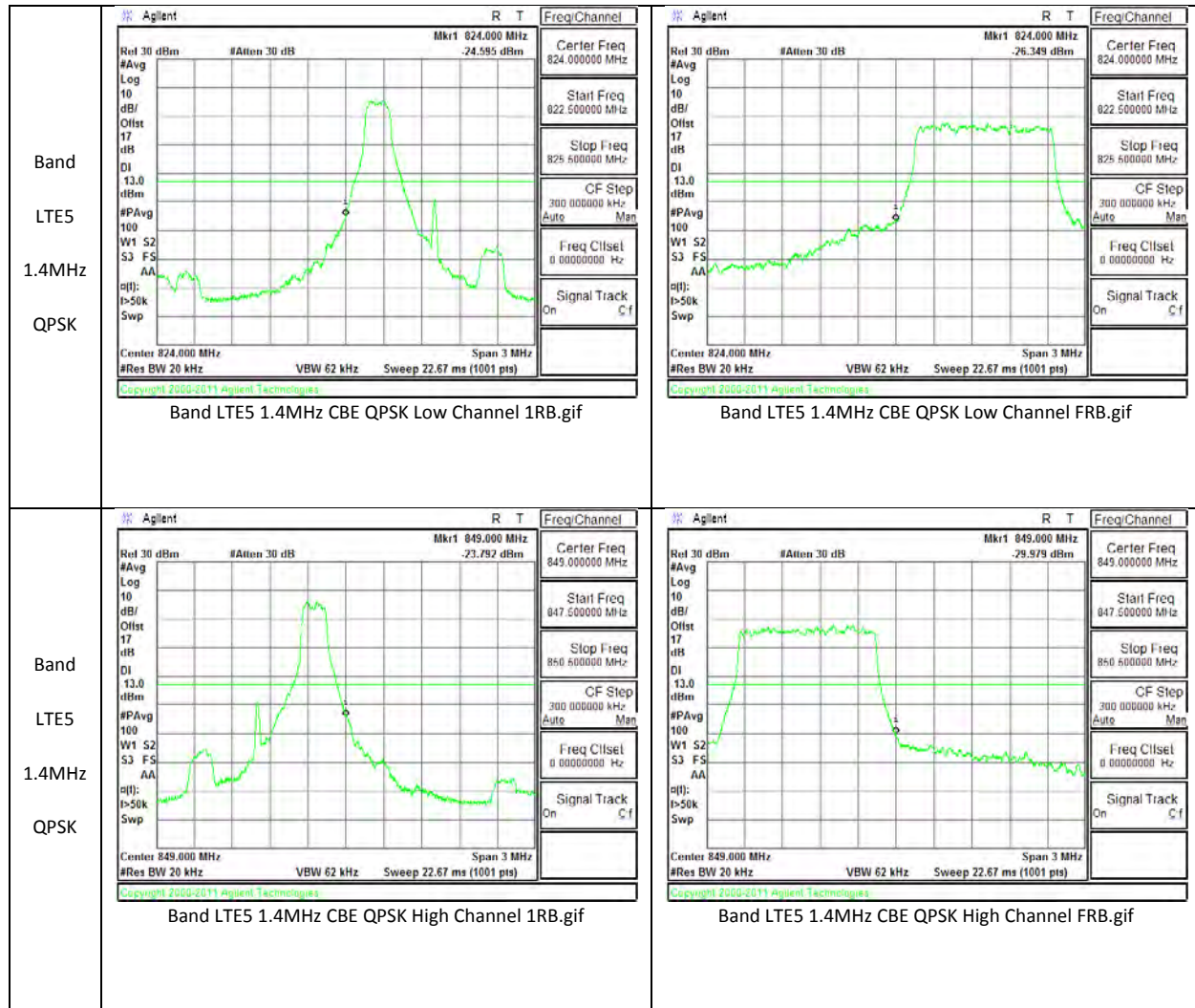

10.3. OUT OF BAND EMISSIONS

RULE PART(S)

FCC: §2.1051, §22.901, §22.917, and §24.238

LIMITS

The power of any emission outside of the authorized operating frequency ranges must be attenuated below the transmitting power (P) by a factor of at least $43 + 10 \log (P)$ dB.

TEST PROCEDURE

Per KDB 971168 D01 Power Meas License Digital Systems v02r01

The RF output of the transmitter was connected to a spectrum analyzer through a calibrated coaxial cable. Sufficient scans were taken to show the out-of-band Emissions, if any, up to 10th harmonic. Multiple sweeps were recorded in maximum hold mode using a peak detector to ensure that the worst-case emissions were caught.

MODES TESTED

GSM, WCDMA, and LTE Band 5

RESULTS

10.3.1. OUT OF BAND EMISSIONS RESULT

Band	BW (MHz)	Mode	f (MHz)	Spur (dBm)	Spec (dBm)	Delta (dB)
LTE5	10	QPSK	829	-28.55	-13	-15.55
			836.5	-27.93	-13	-14.93
			844	-28.69	-13	-15.69
		16QAM	829	-28.62	-13	-15.62
			836.5	-29.97	-13	-16.97
			844	-28.6	-13	-15.6

Band	BW (MHz)	Mode	f (MHz)	Spur (dBm)	Spec (dBm)	Delta (dB)
LTE5	5	QPSK	826.5	-28.28	-13	-15.28
			836.5	-28.28	-13	-15.28
			846.5	-28.57	-13	-15.57
		16QAM	826.5	-28.83	-13	-15.83
			836.5	-28.78	-13	-15.78
			846.5	-29.62	-13	-16.62

Band	BW (MHz)	Mode	f (MHz)	Spur (dBm)	Spec (dBm)	Delta (dB)
LTE5	3	QPSK	825.5	-28	-13	-15
			836.5	-28.15	-13	-15.15
			847.5	-28.94	-13	-15.94
		16QAM	825.5	-29.38	-13	-16.38
			836.5	-28.67	-13	-15.67
			847.5	-28.56	-13	-15.56

Band	BW (MHz)	Mode	f (MHz)	Spur (dBm)	Spec (dBm)	Delta (dB)
LTE5	1.4	QPSK	824.7	-21.19	-13	-8.19
			836.5	-21.82	-13	-8.82
			848.3	-20.7	-13	-7.7
		16QAM	824.7	-20.63	-13	-7.63
			836.5	-20.89	-13	-7.89
			848.3	-20.52	-13	-7.52

Band	Mode	f (MHz)	Spur (dBm)	Spec (dBm)	Delta (dB)
GSM850	GMSK	824.2			
		836.6			
		848.8			
	GPRS	824.2	-29.65	-13	-16.65
		836.6	-29.54	-13	-16.54
		848.8	-30.15	-13	-17.15
	EGPRS	824.2	-29.31	-13	-16.31
		836.6	-28.68	-13	-15.68
		848.8	-28.97	-13	-15.97
GSM1900	GMSK	1850.2			
		1880			
		1909.8			
	GPRS	1850.2	-19.05	-13	-6.05
		1880	-19.96	-13	-6.96
		1909.8	-18.62	-13	-5.62
	EGPRS	1850.2	-19.29	-13	-6.29
		1880	-19	-13	-6
		1909.8	-19.12	-13	-6.12

Band	Mode	f (MHz)	Spur (dBm)	Spec (dBm)	Delta (dB)
Band 5	REL99	826.4	-27.03	-13	-14.03
		836.6	-28	-13	-15
		846.6	-27.75	-13	-14.75
	HSDPA	826.4	-27.1	-13	-14.1
		836.6	-28.01	-13	-15.01
		846.6	-26.95	-13	-13.95
Band 2	REL99	1852.4	-26.11	-13	-13.11
		1880	-27.72	-13	-14.72
		1907.6	-27	-13	-14
	HSDPA	1852.4	-27.16	-13	-14.16
		1880	-28.19	-13	-15.19
		1907.6	-26.78	-13	-13.78

10.3.2. OUT OF BAND EMISSIONS PLOTS

WCDMA

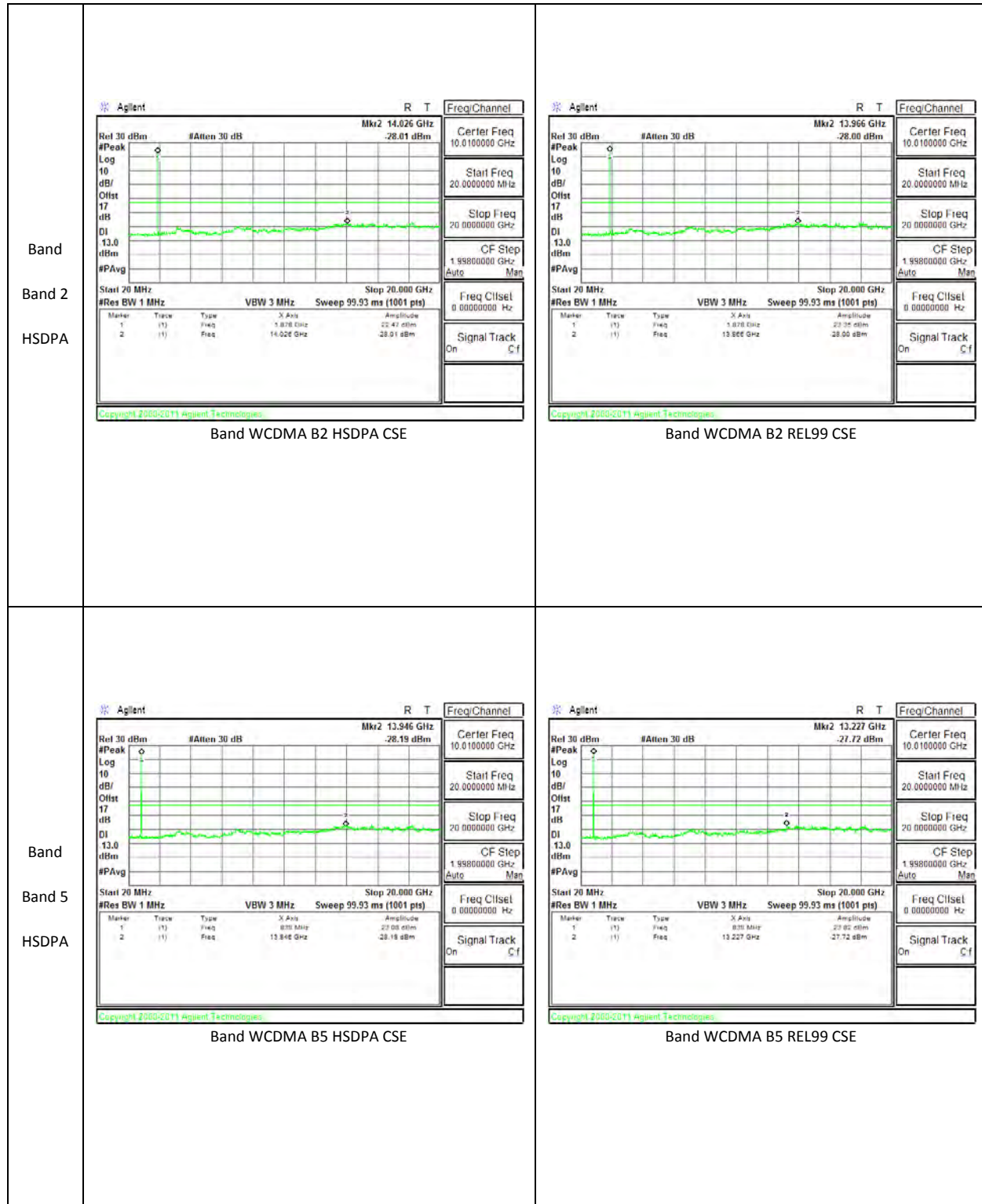

GSM

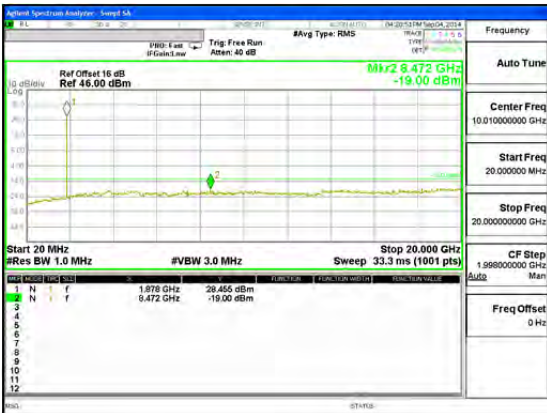
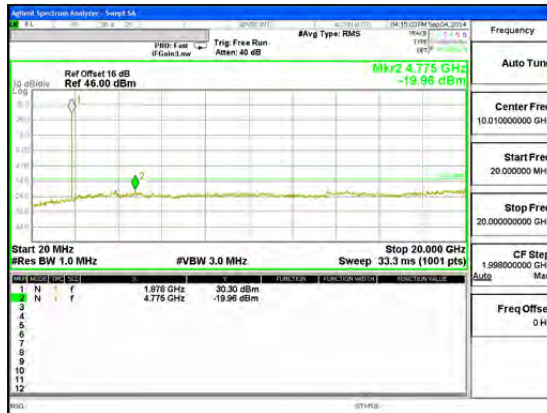
<p>Band GSM 1900 EGPRS</p>	 <p>Band GSM1900 EGPRS CSE Mid channel</p>	 <p>Band GSM1900 GPRS CSE Mid channel</p>
<p>Band GSM 850 EGPRS</p>	 <p>Band GSM850 EGPRS CSE Mid channel</p>	 <p>Band GSM850 GPRS CSE Mid channel</p>

LTE Band 5

<p>Band LTE5 10MHz 16QAM</p>	<p>Agilent 11:22:02 Sep 6, 2014</p> <p>Mkr1 839 MHz 27.974 dBm</p> <p>Center Freq 10.0100000 GHz</p> <p>Start Freq 20.0000000 MHz</p> <p>Stop Freq 20.0000000 GHz</p> <p>CF Step 1.99800000 GHz</p> <p>Start 20 MHz #Res BW 1 MHz VBW 3 MHz Sweep 99.93 ms (1001 pts)</p> <table border="1"> <thead> <tr> <th>Marker</th> <th>Trace</th> <th>Type</th> <th>Freq</th> <th>Amplitude</th> </tr> </thead> <tbody> <tr> <td>1</td> <td>1(1)</td> <td>Freq</td> <td>839 MHz</td> <td>27.97 dBm</td> </tr> <tr> <td>2</td> <td>1(1)</td> <td>Freq</td> <td>14.040 GHz</td> <td>-28.08 dBm</td> </tr> </tbody> </table> <p>Band LTE5 10MHz CSE 16QAM Mid channel</p>	Marker	Trace	Type	Freq	Amplitude	1	1(1)	Freq	839 MHz	27.97 dBm	2	1(1)	Freq	14.040 GHz	-28.08 dBm	<p>Agilent 11:23:52 Sep 6, 2014</p> <p>Mkr1 839 MHz 27.174 dBm</p> <p>Center Freq 10.0100000 GHz</p> <p>Start Freq 20.0000000 MHz</p> <p>Stop Freq 20.0000000 GHz</p> <p>CF Step 1.99800000 GHz</p> <p>Start 20 MHz #Res BW 1 MHz VBW 3 MHz Sweep 99.93 ms (1001 pts)</p> <table border="1"> <thead> <tr> <th>Marker</th> <th>Trace</th> <th>Type</th> <th>Freq</th> <th>Amplitude</th> </tr> </thead> <tbody> <tr> <td>1</td> <td>1(1)</td> <td>Freq</td> <td>839 MHz</td> <td>27.17 dBm</td> </tr> <tr> <td>2</td> <td>1(1)</td> <td>Freq</td> <td>14.020 GHz</td> <td>-27.93 dBm</td> </tr> </tbody> </table> <p>Band LTE5 10MHz CSE QPSK Mid channel</p>	Marker	Trace	Type	Freq	Amplitude	1	1(1)	Freq	839 MHz	27.17 dBm	2	1(1)	Freq	14.020 GHz	-27.93 dBm
Marker	Trace	Type	Freq	Amplitude																												
1	1(1)	Freq	839 MHz	27.97 dBm																												
2	1(1)	Freq	14.040 GHz	-28.08 dBm																												
Marker	Trace	Type	Freq	Amplitude																												
1	1(1)	Freq	839 MHz	27.17 dBm																												
2	1(1)	Freq	14.020 GHz	-27.93 dBm																												
<p>Band LTE5 5MHz 16QAM</p>	<p>Agilent 11:31:20 Sep 6, 2014</p> <p>Mkr1 839 MHz 27.403 dBm</p> <p>Center Freq 10.0100000 GHz</p> <p>Start Freq 20.0000000 MHz</p> <p>Stop Freq 20.0000000 GHz</p> <p>CF Step 1.99800000 GHz</p> <p>Start 20 MHz #Res BW 1 MHz VBW 3 MHz Sweep 99.93 ms (1001 pts)</p> <table border="1"> <thead> <tr> <th>Marker</th> <th>Trace</th> <th>Type</th> <th>Freq</th> <th>Amplitude</th> </tr> </thead> <tbody> <tr> <td>1</td> <td>1(1)</td> <td>Freq</td> <td>839 MHz</td> <td>27.40 dBm</td> </tr> <tr> <td>2</td> <td>1(1)</td> <td>Freq</td> <td>14.020 GHz</td> <td>-28.78 dBm</td> </tr> </tbody> </table> <p>Band LTE5 5MHz CSE 16QAM Mid channel</p>	Marker	Trace	Type	Freq	Amplitude	1	1(1)	Freq	839 MHz	27.40 dBm	2	1(1)	Freq	14.020 GHz	-28.78 dBm	<p>Agilent 11:33:40 Sep 6, 2014</p> <p>Mkr2 14.026 GHz 28.284 dBm</p> <p>Center Freq 10.0100000 GHz</p> <p>Start Freq 20.0000000 MHz</p> <p>Stop Freq 20.0000000 GHz</p> <p>CF Step 1.99800000 GHz</p> <p>Start 20 MHz #Res BW 1 MHz VBW 3 MHz Sweep 99.93 ms (1001 pts)</p> <table border="1"> <thead> <tr> <th>Marker</th> <th>Trace</th> <th>Type</th> <th>Freq</th> <th>Amplitude</th> </tr> </thead> <tbody> <tr> <td>1</td> <td>1(1)</td> <td>Freq</td> <td>14.026 GHz</td> <td>28.28 dBm</td> </tr> <tr> <td>2</td> <td>1(1)</td> <td>Freq</td> <td>14.020 GHz</td> <td>-28.28 dBm</td> </tr> </tbody> </table> <p>Band LTE5 5MHz CSE QPSK Mid channel</p>	Marker	Trace	Type	Freq	Amplitude	1	1(1)	Freq	14.026 GHz	28.28 dBm	2	1(1)	Freq	14.020 GHz	-28.28 dBm
Marker	Trace	Type	Freq	Amplitude																												
1	1(1)	Freq	839 MHz	27.40 dBm																												
2	1(1)	Freq	14.020 GHz	-28.78 dBm																												
Marker	Trace	Type	Freq	Amplitude																												
1	1(1)	Freq	14.026 GHz	28.28 dBm																												
2	1(1)	Freq	14.020 GHz	-28.28 dBm																												

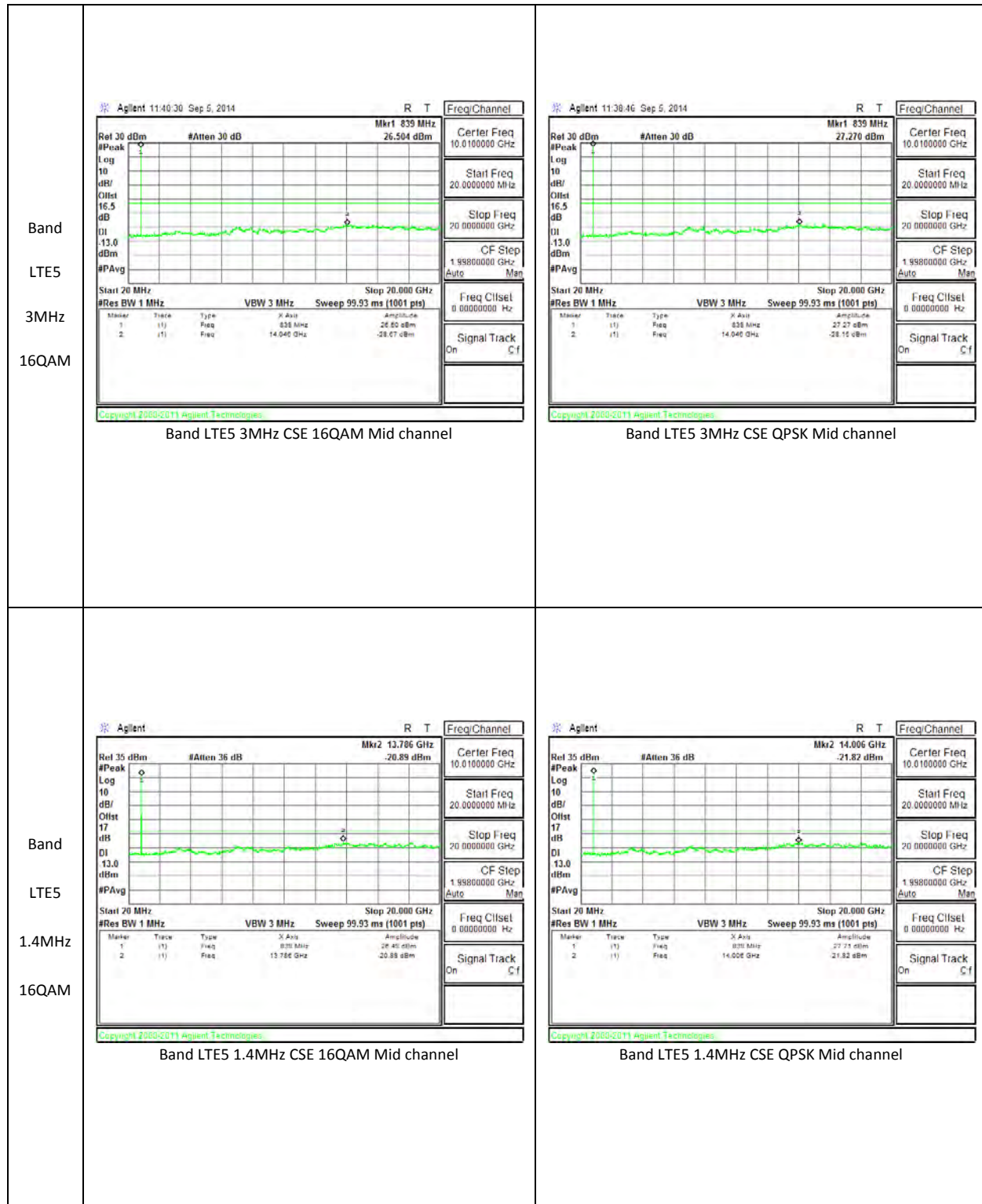

10.4. FREQUENCY STABILITY

RULE PART(S)

FCC: §2.1055, §22.355, §24.235

LIMITS

§22.355 - The carrier frequency shall not depart from the reference frequency in excess of ± 2.5 ppm for mobile stations.

§24.235 - The frequency stability shall be sufficient to ensure that the fundamental emission stays within the authorized frequency block.

TEST PROCEDURE

Per KDB 971168 D01 Power Meas License Digital Systems v02r01

MODES TESTED

GSM 850 and GSM1900

RESULTS

See the following pages.

10.4.1. FREQUENCY STABILITY RESULTS

GPRS 850 CELL BAND, MID CHANNEL190, Frequency 836.6MHz

Reference Frequency: PCS Mid Channel 836.6 MHz @ 20°C Limit: to stay +/- 2.5 ppm = 2091.500 Hz				
Power Supply (Vdc)	Environment Temperature (°C)	Frequency Deviation Measured with Time Elapse		
		(MHz)	Delta (ppm)	Limit (ppm)
3.80	50	836.599992	0.022	2.5
3.80	40	836.600009	0.002	2.5
3.80	30	836.600009	0.002	2.5
3.80	20	836.600011	0	2.5
3.80	10	836.600026	-0.018	2.5
3.80	0	836.600009	0.002	2.5
3.80	-10	836.599988	0.027	2.5
3.80	-20	836.599992	0.023	2.5
3.80	-30	836.599978	0.040	2.5

Reference Frequency: PCS Mid Channel 836.6 MHz @ 20°C Limit: to stay +/- 2.5 ppm = 2091.500 Hz				
Power Supply (Vdc)	Environment Temperature (°C)	Frequency Deviation Measured with Time Elapse		
		(MHz)	Delta (ppm)	Limit (ppm)
3.80	20	836.600011	0	2.5
4.30	20	836.5999832	0.033	2.5
3.20	20	836.5999745	0.043	2.5

GPRS 1900 CELL BAND, MID CHANNEL 661, Frequency 1880 MHz

Reference Frequency: PCS Mid Channel 1880 MHz @ 20°C Limit: to stay +/- 2.5 ppm = 4700.000 Hz				
Power Supply (Vdc)	Environment Temperature (°C)	Frequency Deviation Measured with Time Elapse		
		(MHz)	Delta (ppm)	Limit (ppm)
3.80	50	1879.999985	0.047	2.5
3.80	40	1879.999942	0.070	2.5
3.80	30	1880.000019	0.029	2.5
3.80	20	1880.000073	0	2.5
3.80	10	1880.000020	0.028	2.5
3.80	0	1879.999970	0.055	2.5
3.80	-10	1880.000025	0.026	2.5
3.80	-20	1879.999960	0.060	2.5
3.80	-30	1879.999950	0.065	2.5

Reference Frequency: PCS Mid Channel 1880 MHz @ 20°C Limit: to stay +/- 2.5 ppm = 4700.000 Hz				
Power Supply (Vdc)	Environment Temperature (°C)	Frequency Deviation Measured with Time Elapse		
		(MHz)	Delta (ppm)	Limit (ppm)
3.80	20	1880.000073	0	2.5
4.30	20	1880.000013	0.032	2.5
3.20	20	1880.000019	0.029	2.5

11. RADIATED TEST RESULTS

11.1. RADIATED POWER (ERP & EIRP)

RULE PART(S)

FCC: §2.1046, §22.913, §24.232.

LIMITS

22.913(a) - The ERP of mobile transmitters and auxiliary test transmitters must not exceed 7 Watts.

24.232(c) - Mobile/portable stations are limited to 2 watts e.i.r.p. peak power and the equipment must employ means to limit the power to the minimum necessary for successful communications.

In addition, when the transmitter power is measured in terms of average value, the peak-to-average ratio of the power shall not exceed 13dB.

TEST PROCEDURE

ANSI / TIA / EIA 603C Clause 2.2.17; PSA setting reference to 971168 D01 v02r01

For peak power measurement with a PSA:

a) Set the RBW \geq OBW; b) Set VBW $\geq 3 \times$ RBW; c) Set span $\geq 2 \times$ RBW; d) Sweep time = auto couple; e) Detector = peak; f) Ensure that the number of measurement points \geq span/RBW; g) Trace mode = max hold;

For average power measurement with a PSA:

a) Set span to at least 1.5 times the OBW; b) Set RBW = 1-5% of the OBW, not to exceed 1 MHz; c) Set VBW $\geq 3 \times$ RBW; d) Set number of points in sweep $\geq 2 \times$ span / RBW; e) Sweep time = auto-couple; f) Detector = RMS (power averaging); g) Use free run trigger If burst duty cycle ≥ 98 ; h) Use trigger to capture bursts If burst duty cycle < 98 ; i) Trace average at least 100 traces in power averaging (*i.e.*, RMS) mode. j) Compute the power by integrating the spectrum across the OBW of the signal using the instrument's band power measurement function.

TEST RESULTS

11.1.1. ERP/EIRP Results

Band	Mode	Channel	f(MHz)	ERP / EIRP	
				dBm	mW
Band 2	REL99	9262	1852.4	19.23	83.8
		9400	1880	20.40	109.6
		9538	1907.6	21.05	127.4
	HSDPA	9262	1852.4	18.92	78.0
		9400	1880	20.14	103.3
		9538	1907.6	20.16	103.8

Band	Mode	Channel	f(MHz)	ERP / EIRP	
				dBm	mW
Band 5	REL99	4132	826.4	15.60	36.3
		4183	836.6	15.21	33.2
		4233	846.6	15.17	32.9
	HSDPA	4132	826.4	14.11	25.8
		4183	836.6	14.01	25.2
		4233	846.6	14.15	26.0

Band	Mode	Channel	f(MHz)	ERP / EIRP	
				dBm	mW
GSM1900	GPRS	512	1850.2	25.21	331.9
		661	1880	26.77	475.3
		810	1909.8	25.96	394.5
	EGPRS	512	1850.2	21.86	153.5
		661	1880	23.57	227.5
		810	1909.8	22.95	197.2

Band	Mode	Channel	f(MHz)	ERP / EIRP	
				dBm	mW
GSM850	GPRS	128	824.2	23.40	218.8
		190	836.6	24.73	297.2
		251	848.8	25.70	371.5
	EGPRS	128	824.2	20.57	114.0
		190	836.6	21.29	134.6
		251	848.8	22.00	158.5

11.1.2. LTE ERP/EIRP Results

Band	BW (MHz)	Mode	RB/RB Size	f (MHz)	ERP / EIRP	
					dBm	mW
LTE5	10	QPSK	1/0	829	14.85	30.55
			1/0	836.5	15.38	34.51
			1/0	844	15.85	38.46
		16QAM	1/0	829	14.40	27.54
			1/0	836.5	14.25	26.61
			1/0	844	14.78	30.06

Band	BW (MHz)	Mode	RB/RB Size	f (MHz)	ERP / EIRP	
					dBm	mW
LTE5	5	QPSK	1/0	826.5	15.16	32.81
			1/0	836.5	15.27	33.65
			1/0	846.5	14.80	30.20
		16QAM	1/0	826.5	14.26	26.67
			1/0	836.5	14.47	27.99
			1/0	846.5	14.24	26.55

Band	BW (MHz)	Mode	RB/RB Size	f (MHz)	ERP / EIRP	
					dBm	mW
LTE5	3	QPSK	1/0	825.5	14.77	29.99
			1/0	836.5	15.21	33.19
			1/0	847.5	14.91	30.97
		16QAM	1/0	825.5	13.92	24.66
			1/0	836.5	14.32	27.04
			1/0	847.5	14.44	27.80

Band	BW (MHz)	Mode	RB/RB Size	f (MHz)	ERP / EIRP	
					dBm	mW
LTE5	1.4	QPSK	1/0	824.7	14.56	28.58
			1/0	836.5	15.55	35.89
			1/0	848.3	15.79	37.93
		16QAM	1/0	824.7	14.06	25.47
			1/0	836.5	14.05	25.41
			1/0	848.3	14.31	26.98

11.1.3. ERP/EIRP DATA

WCDMA

Band Band 2 HSDPA	UL Verification Services, Inc. Chamber B								
	Company:		Samsung						
	Project #:		14I19248						
	Date:		10/30/14						
	Test Engineer:		R. Alegre						
	Configuration:		EUT only(1987514)						
	Mode:		HSDPA B2						
	Test Equipment:								
	Receiving: Horn T345, and Chamber B SMA Cables								
	Substitution: Horn T59, 8ft SMA Cable (SN # 245185 003) Warehouse.								
	f	SG reading	Ant. Pol.	Cable Loss	Antenna Gain	EIRP	Limit	Margin	Notes
	MHz	(dBm)	(H/V)	(dB)	(dBi)	(dBm)	(dBm)	(dB)	
	Low Ch								
	1852.40	7.97	V	0.90	7.90	14.97	33.0	-18.0	
	1852.40	11.92	H	0.90	7.90	18.92	33.0	-14.1	
	Mid Ch								
	1880.00	10.07	V	0.90	7.90	17.07	33.0	-15.9	
	1880.00	13.14	H	0.90	7.90	20.14	33.0	-12.9	
	High Ch								
	1907.60	8.68	V	0.90	7.90	15.68	33.0	-17.3	
	1907.60	13.16	H	0.90	7.90	20.16	33.0	-12.8	
	Rev. 3.17.11								
	Note: For Band 4 EIRP limit is 30dBm								

Band Band 2 REL99	High Frequency Substitution Measurement UL Verification Services, Inc. Chamber B																																																																																																					
	Company:		Samsung																																																																																																			
	Project #:		14I19248																																																																																																			
	Date:		10/30/14																																																																																																			
	Test Engineer:		R. Alegre																																																																																																			
	Configuration:		EUT only(1987514)																																																																																																			
	Mode:		WCDMA_1900 MHz_Rel 99																																																																																																			
	Test Equipment:																																																																																																					
	Receiving:		Horn T345, and Chamber B SMA Cables																																																																																																			
	Substitution:		Horn T59, 8ft SMA Cable (SN # 245185 003) Warehouse.																																																																																																			
<table border="1"> <thead> <tr> <th>f MHz</th> <th>SG reading (dBm)</th> <th>Ant. Pol. (H/V)</th> <th>Cable Loss (dB)</th> <th>Antenna Gain (dBi)</th> <th>EIRP (dBm)</th> <th>Limit (dBm)</th> <th>Margin (dB)</th> <th>Notes</th> </tr> </thead> <tbody> <tr> <td colspan="10">Low Ch</td> </tr> <tr> <td>1852.40</td> <td>8.41</td> <td>V</td> <td>0.90</td> <td>7.90</td> <td>15.41</td> <td>33.0</td> <td>-17.6</td> <td></td> </tr> <tr> <td>1852.40</td> <td>12.23</td> <td>H</td> <td>0.90</td> <td>7.90</td> <td>19.23</td> <td>33.0</td> <td>-13.8</td> <td></td> </tr> <tr> <td colspan="10">Mid Ch</td> </tr> <tr> <td>1880.00</td> <td>10.70</td> <td>V</td> <td>0.90</td> <td>7.90</td> <td>17.70</td> <td>33.0</td> <td>-15.3</td> <td></td> </tr> <tr> <td>1880.00</td> <td>13.40</td> <td>H</td> <td>0.90</td> <td>7.90</td> <td>20.40</td> <td>33.0</td> <td>-12.6</td> <td></td> </tr> <tr> <td colspan="10">High Ch</td> </tr> <tr> <td>1907.60</td> <td>9.11</td> <td>V</td> <td>0.90</td> <td>7.90</td> <td>16.11</td> <td>33.0</td> <td>-16.9</td> <td></td> </tr> <tr> <td>1907.60</td> <td>14.05</td> <td>H</td> <td>0.90</td> <td>7.90</td> <td>21.05</td> <td>33.0</td> <td>-12.0</td> <td></td> </tr> </tbody> </table>										f MHz	SG reading (dBm)	Ant. Pol. (H/V)	Cable Loss (dB)	Antenna Gain (dBi)	EIRP (dBm)	Limit (dBm)	Margin (dB)	Notes	Low Ch										1852.40	8.41	V	0.90	7.90	15.41	33.0	-17.6		1852.40	12.23	H	0.90	7.90	19.23	33.0	-13.8		Mid Ch										1880.00	10.70	V	0.90	7.90	17.70	33.0	-15.3		1880.00	13.40	H	0.90	7.90	20.40	33.0	-12.6		High Ch										1907.60	9.11	V	0.90	7.90	16.11	33.0	-16.9		1907.60	14.05	H	0.90	7.90	21.05	33.0	-12.0	
f MHz	SG reading (dBm)	Ant. Pol. (H/V)	Cable Loss (dB)	Antenna Gain (dBi)	EIRP (dBm)	Limit (dBm)	Margin (dB)	Notes																																																																																														
Low Ch																																																																																																						
1852.40	8.41	V	0.90	7.90	15.41	33.0	-17.6																																																																																															
1852.40	12.23	H	0.90	7.90	19.23	33.0	-13.8																																																																																															
Mid Ch																																																																																																						
1880.00	10.70	V	0.90	7.90	17.70	33.0	-15.3																																																																																															
1880.00	13.40	H	0.90	7.90	20.40	33.0	-12.6																																																																																															
High Ch																																																																																																						
1907.60	9.11	V	0.90	7.90	16.11	33.0	-16.9																																																																																															
1907.60	14.05	H	0.90	7.90	21.05	33.0	-12.0																																																																																															
Rev. 3.17.11																																																																																																						
Note: For Band 4 EIRP limit is 30dBm																																																																																																						

Band Band 5 REL99	High Frequency Substitution Measurement UL Verification Services, Inc. Chamber C																																																																																																	
	Company:		Samsung																																																																																															
	Project #:		14I19248																																																																																															
	Date:		11/03/14																																																																																															
	Test Engineer:		Jude Semana																																																																																															
	Configuration:		X-pos EUT Only (1987515)																																																																																															
	Mode:		WCDMA_Rel99_850																																																																																															
	Test Equipment:																																																																																																	
	Receiving: Sunol T185, and Chamber C N-type Cable																																																																																																	
	Substitution: Dipole T273, 4ft SMA Cable Warehouse.																																																																																																	
<table border="1"> <thead> <tr> <th>f MHz</th> <th>SG reading (dBm)</th> <th>Ant. Pol. (H/V)</th> <th>Cable Loss (dB)</th> <th>Antenna Gain (dBd)</th> <th>ERP (dBm)</th> <th>Limit (dBm)</th> <th>Margin (dB)</th> <th>Notes</th> </tr> </thead> <tbody> <tr> <td colspan="9">Low Ch</td> </tr> <tr> <td>826.40</td> <td>9.10</td> <td>V</td> <td>0.9</td> <td>0.0</td> <td>8.20</td> <td>38.5</td> <td>-30.2</td> <td></td> </tr> <tr> <td>826.40</td> <td>16.50</td> <td>H</td> <td>0.9</td> <td>0.0</td> <td>15.60</td> <td>38.5</td> <td>-22.8</td> <td></td> </tr> <tr> <td colspan="9">Mid Ch</td> </tr> <tr> <td>836.60</td> <td>8.94</td> <td>V</td> <td>0.9</td> <td>0.0</td> <td>8.04</td> <td>38.5</td> <td>-30.4</td> <td></td> </tr> <tr> <td>836.60</td> <td>16.11</td> <td>H</td> <td>0.9</td> <td>0.0</td> <td>15.21</td> <td>38.5</td> <td>-23.2</td> <td></td> </tr> <tr> <td colspan="9">High Ch</td> </tr> <tr> <td>846.60</td> <td>8.76</td> <td>V</td> <td>0.9</td> <td>0.0</td> <td>7.86</td> <td>38.5</td> <td>-30.6</td> <td></td> </tr> <tr> <td>846.60</td> <td>16.07</td> <td>H</td> <td>0.9</td> <td>0.0</td> <td>15.17</td> <td>38.5</td> <td>-23.3</td> <td></td> </tr> </tbody> </table>									f MHz	SG reading (dBm)	Ant. Pol. (H/V)	Cable Loss (dB)	Antenna Gain (dBd)	ERP (dBm)	Limit (dBm)	Margin (dB)	Notes	Low Ch									826.40	9.10	V	0.9	0.0	8.20	38.5	-30.2		826.40	16.50	H	0.9	0.0	15.60	38.5	-22.8		Mid Ch									836.60	8.94	V	0.9	0.0	8.04	38.5	-30.4		836.60	16.11	H	0.9	0.0	15.21	38.5	-23.2		High Ch									846.60	8.76	V	0.9	0.0	7.86	38.5	-30.6		846.60	16.07	H	0.9	0.0	15.17	38.5	-23.3	
f MHz	SG reading (dBm)	Ant. Pol. (H/V)	Cable Loss (dB)	Antenna Gain (dBd)	ERP (dBm)	Limit (dBm)	Margin (dB)	Notes																																																																																										
Low Ch																																																																																																		
826.40	9.10	V	0.9	0.0	8.20	38.5	-30.2																																																																																											
826.40	16.50	H	0.9	0.0	15.60	38.5	-22.8																																																																																											
Mid Ch																																																																																																		
836.60	8.94	V	0.9	0.0	8.04	38.5	-30.4																																																																																											
836.60	16.11	H	0.9	0.0	15.21	38.5	-23.2																																																																																											
High Ch																																																																																																		
846.60	8.76	V	0.9	0.0	7.86	38.5	-30.6																																																																																											
846.60	16.07	H	0.9	0.0	15.17	38.5	-23.3																																																																																											
Rev. 3.17.11																																																																																																		
Note: For Band 13/17 ERP limit is 34.77dBm; For Band 26 limit is 50dBm																																																																																																		

GSM

High Frequency Substitution Measurement UL Verification Services, Inc. Chamber B									
Company:		Samsung							
Project #:		14119248							
Date:		10/30/14							
Test Engineer:		R. Alegre							
Configuration:		EUT only(1987514)							
Mode:		GPRS 1900							
Test Equipment:									
Receiving: Horn T345, and Chamber B SMA Cables									
Substitution: Horn T59 Substitution, 4ft SMA Cable Warehouse									
Band	f	SG reading	Ant. Pol.	Cable Loss	Antenna Gain	EIRP	Limit	Margin	Notes
GSM	MHz	(dBm)	(H/V)	(dB)	(dBi)	(dBm)	(dBm)	(dB)	
1900	Low								
	1850.20	9.92	V	0.90	7.90	16.92	33.0	-16.1	
	1850.20	14.86	H	0.90	7.90	21.86	33.0	-11.1	
	Mid								
	1880.00	10.30	V	0.90	7.90	17.30	33.0	-15.7	
	1880.00	16.57	H	0.90	7.90	23.57	33.0	-9.4	
	High								
	1909.80	9.36	V	0.90	7.90	16.36	33.0	-16.6	
	1909.80	15.95	H	0.90	7.90	22.95	33.0	-10.1	
EGPRS	Rev. 3.17.11 Note: For Band 4 EIRP limit is 30dBm								

Band GSM 850 EGPRS	High Frequency Substitution Measurement UL Verification Services, Inc. Chamber B																																																																																																						
	Company:		Samsung																																																																																																				
	Project #:		14I19248																																																																																																				
	Date:		10/30/14																																																																																																				
	Test Engineer:		L. Lara																																																																																																				
	Configuration:		X-pos EUT Only (1987515)																																																																																																				
	Mode:		EGPRS850																																																																																																				
	Test Equipment:		Receiving: Sunol T243, and Chamber B N-type Cable Substitution: Dipole T273, 4ft SMA Cable Warehouse.																																																																																																				
	<table border="1"> <thead> <tr> <th>f MHz</th> <th>SG reading (dBm)</th> <th>Ant. Pol. (H/V)</th> <th>Cable Loss (dB)</th> <th>Antenna Gain (dBd)</th> <th>ERP (dBm)</th> <th>Limit (dBm)</th> <th>Margin (dB)</th> <th>Notes</th> </tr> </thead> <tbody> <tr> <td colspan="10">Low Ch</td> </tr> <tr> <td>824.20</td> <td>9.05</td> <td>V</td> <td>0.8</td> <td>0.0</td> <td>8.25</td> <td>38.5</td> <td>-30.2</td> <td></td> </tr> <tr> <td>824.20</td> <td>21.37</td> <td>H</td> <td>0.8</td> <td>0.0</td> <td>20.57</td> <td>38.5</td> <td>-17.9</td> <td></td> </tr> <tr> <td colspan="10">Mid Ch</td> </tr> <tr> <td>836.60</td> <td>10.90</td> <td>V</td> <td>0.8</td> <td>0.0</td> <td>10.10</td> <td>38.5</td> <td>-28.3</td> <td></td> </tr> <tr> <td>836.60</td> <td>22.09</td> <td>H</td> <td>0.8</td> <td>0.0</td> <td>21.29</td> <td>38.5</td> <td>-17.2</td> <td></td> </tr> <tr> <td colspan="10">High Ch</td> </tr> <tr> <td>848.80</td> <td>11.06</td> <td>V</td> <td>0.8</td> <td>0.0</td> <td>10.26</td> <td>38.5</td> <td>-28.2</td> <td></td> </tr> <tr> <td>848.80</td> <td>22.80</td> <td>H</td> <td>0.8</td> <td>0.0</td> <td>22.00</td> <td>38.5</td> <td>-16.4</td> <td></td> </tr> </tbody> </table>										f MHz	SG reading (dBm)	Ant. Pol. (H/V)	Cable Loss (dB)	Antenna Gain (dBd)	ERP (dBm)	Limit (dBm)	Margin (dB)	Notes	Low Ch										824.20	9.05	V	0.8	0.0	8.25	38.5	-30.2		824.20	21.37	H	0.8	0.0	20.57	38.5	-17.9		Mid Ch										836.60	10.90	V	0.8	0.0	10.10	38.5	-28.3		836.60	22.09	H	0.8	0.0	21.29	38.5	-17.2		High Ch										848.80	11.06	V	0.8	0.0	10.26	38.5	-28.2		848.80	22.80	H	0.8	0.0	22.00	38.5	-16.4	
	f MHz	SG reading (dBm)	Ant. Pol. (H/V)	Cable Loss (dB)	Antenna Gain (dBd)	ERP (dBm)	Limit (dBm)	Margin (dB)	Notes																																																																																														
Low Ch																																																																																																							
824.20	9.05	V	0.8	0.0	8.25	38.5	-30.2																																																																																																
824.20	21.37	H	0.8	0.0	20.57	38.5	-17.9																																																																																																
Mid Ch																																																																																																							
836.60	10.90	V	0.8	0.0	10.10	38.5	-28.3																																																																																																
836.60	22.09	H	0.8	0.0	21.29	38.5	-17.2																																																																																																
High Ch																																																																																																							
848.80	11.06	V	0.8	0.0	10.26	38.5	-28.2																																																																																																
848.80	22.80	H	0.8	0.0	22.00	38.5	-16.4																																																																																																
Rev. 3.17.11 Note: For Band 13/17 ERP limit is 34.77dBm; For Band 26 limit is 50dBm																																																																																																							

Band GSM 850 GPRS	High Frequency Substitution Measurement UL Verification Services, Inc. Chamber B																																																																																																					
	Company:		Samsung																																																																																																			
	Project #:		14I19248																																																																																																			
	Date:		10/30/14																																																																																																			
	Test Engineer:		O. Stoelting, L. Lara																																																																																																			
	Configuration:		X-pos EUT Only (1987515)																																																																																																			
	Mode:		GPRS850																																																																																																			
	Test Equipment:																																																																																																					
	Receiving: Sunol T243, and Chamber B N-type Cable																																																																																																					
	Substitution: Dipole T273, 4ft SMA Cable Warehouse.																																																																																																					
<table border="1"> <thead> <tr> <th>f MHz</th> <th>SG reading (dBm)</th> <th>Ant. Pol. (H/V)</th> <th>Cable Loss (dB)</th> <th>Antenna Gain (dBd)</th> <th>ERP (dBm)</th> <th>Limit (dBm)</th> <th>Margin (dB)</th> <th>Notes</th> </tr> </thead> <tbody> <tr> <td colspan="10">Low Ch</td> </tr> <tr> <td>824.20</td> <td>11.34</td> <td>V</td> <td>0.9</td> <td>0.0</td> <td>10.45</td> <td>38.5</td> <td>-28.0</td> <td></td> </tr> <tr> <td>824.20</td> <td>24.29</td> <td>H</td> <td>0.9</td> <td>0.0</td> <td>23.40</td> <td>38.5</td> <td>-15.1</td> <td></td> </tr> <tr> <td colspan="10">Mid Ch</td> </tr> <tr> <td>836.60</td> <td>14.51</td> <td>V</td> <td>0.9</td> <td>0.0</td> <td>13.62</td> <td>38.5</td> <td>-24.8</td> <td></td> </tr> <tr> <td>836.60</td> <td>25.63</td> <td>H</td> <td>0.9</td> <td>0.0</td> <td>24.73</td> <td>38.5</td> <td>-13.7</td> <td></td> </tr> <tr> <td colspan="10">High Ch</td> </tr> <tr> <td>848.80</td> <td>12.82</td> <td>V</td> <td>0.9</td> <td>0.0</td> <td>11.92</td> <td>38.5</td> <td>-26.5</td> <td></td> </tr> <tr> <td>848.80</td> <td>26.60</td> <td>H</td> <td>0.9</td> <td>0.0</td> <td>25.70</td> <td>38.5</td> <td>-12.8</td> <td></td> </tr> </tbody> </table>										f MHz	SG reading (dBm)	Ant. Pol. (H/V)	Cable Loss (dB)	Antenna Gain (dBd)	ERP (dBm)	Limit (dBm)	Margin (dB)	Notes	Low Ch										824.20	11.34	V	0.9	0.0	10.45	38.5	-28.0		824.20	24.29	H	0.9	0.0	23.40	38.5	-15.1		Mid Ch										836.60	14.51	V	0.9	0.0	13.62	38.5	-24.8		836.60	25.63	H	0.9	0.0	24.73	38.5	-13.7		High Ch										848.80	12.82	V	0.9	0.0	11.92	38.5	-26.5		848.80	26.60	H	0.9	0.0	25.70	38.5	-12.8	
f MHz	SG reading (dBm)	Ant. Pol. (H/V)	Cable Loss (dB)	Antenna Gain (dBd)	ERP (dBm)	Limit (dBm)	Margin (dB)	Notes																																																																																														
Low Ch																																																																																																						
824.20	11.34	V	0.9	0.0	10.45	38.5	-28.0																																																																																															
824.20	24.29	H	0.9	0.0	23.40	38.5	-15.1																																																																																															
Mid Ch																																																																																																						
836.60	14.51	V	0.9	0.0	13.62	38.5	-24.8																																																																																															
836.60	25.63	H	0.9	0.0	24.73	38.5	-13.7																																																																																															
High Ch																																																																																																						
848.80	12.82	V	0.9	0.0	11.92	38.5	-26.5																																																																																															
848.80	26.60	H	0.9	0.0	25.70	38.5	-12.8																																																																																															
Rev. 3.17.11																																																																																																						
Note: For Band 13/17 ERP limit is 34.77dBm; For Band 26 limit is 50dBm																																																																																																						

LTE Band 5

Band LTE5 10MHz 16QAM	High Frequency Substitution Measurement UL Verification Services, Inc. Chamber C																																																																																																
	Company:		Samsung																																																																																														
	Project #:		14I19248																																																																																														
	Date:		11/03/14																																																																																														
	Test Engineer:		R. Alegre																																																																																														
	Configuration:		X-pos EUT Only (1987514)																																																																																														
	Mode:		LTE5 10MHz 16QAM																																																																																														
	Test Equipment:																																																																																																
	Receiving: Sunol T185, and Chamber C N-type Cable																																																																																																
	Substitution: Dipole T273, 4ft SMA Cable Warehouse.																																																																																																
<table border="1"> <thead> <tr> <th>f MHz</th> <th>SG reading (dBm)</th> <th>Ant. Pol. (H/V)</th> <th>Cable Loss (dB)</th> <th>Antenna Gain (dBd)</th> <th>ERP (dBm)</th> <th>Limit (dBm)</th> <th>Margin (dB)</th> <th>Notes</th> </tr> </thead> <tbody> <tr> <td colspan="9">Low Ch</td> </tr> <tr> <td>829.00</td> <td>5.17</td> <td>V</td> <td>0.9</td> <td>0.0</td> <td>4.27</td> <td>38.5</td> <td>-34.2</td> <td></td> </tr> <tr> <td>829.00</td> <td>15.30</td> <td>H</td> <td>0.9</td> <td>0.0</td> <td>14.40</td> <td>38.5</td> <td>-24.0</td> <td></td> </tr> <tr> <td colspan="9">Mid Ch</td> </tr> <tr> <td>836.50</td> <td>6.08</td> <td>V</td> <td>0.9</td> <td>0.0</td> <td>5.19</td> <td>38.5</td> <td>-33.3</td> <td></td> </tr> <tr> <td>836.50</td> <td>15.15</td> <td>H</td> <td>0.9</td> <td>0.0</td> <td>14.25</td> <td>38.5</td> <td>-24.2</td> <td></td> </tr> <tr> <td colspan="9">High Ch</td> </tr> <tr> <td>844.00</td> <td>5.89</td> <td>V</td> <td>0.9</td> <td>0.0</td> <td>4.99</td> <td>38.5</td> <td>-33.5</td> <td></td> </tr> <tr> <td>844.00</td> <td>15.67</td> <td>H</td> <td>0.9</td> <td>0.0</td> <td>14.78</td> <td>38.5</td> <td>-23.7</td> <td></td> </tr> </tbody> </table>								f MHz	SG reading (dBm)	Ant. Pol. (H/V)	Cable Loss (dB)	Antenna Gain (dBd)	ERP (dBm)	Limit (dBm)	Margin (dB)	Notes	Low Ch									829.00	5.17	V	0.9	0.0	4.27	38.5	-34.2		829.00	15.30	H	0.9	0.0	14.40	38.5	-24.0		Mid Ch									836.50	6.08	V	0.9	0.0	5.19	38.5	-33.3		836.50	15.15	H	0.9	0.0	14.25	38.5	-24.2		High Ch									844.00	5.89	V	0.9	0.0	4.99	38.5	-33.5		844.00	15.67	H	0.9	0.0	14.78	38.5	-23.7	
f MHz	SG reading (dBm)	Ant. Pol. (H/V)	Cable Loss (dB)	Antenna Gain (dBd)	ERP (dBm)	Limit (dBm)	Margin (dB)	Notes																																																																																									
Low Ch																																																																																																	
829.00	5.17	V	0.9	0.0	4.27	38.5	-34.2																																																																																										
829.00	15.30	H	0.9	0.0	14.40	38.5	-24.0																																																																																										
Mid Ch																																																																																																	
836.50	6.08	V	0.9	0.0	5.19	38.5	-33.3																																																																																										
836.50	15.15	H	0.9	0.0	14.25	38.5	-24.2																																																																																										
High Ch																																																																																																	
844.00	5.89	V	0.9	0.0	4.99	38.5	-33.5																																																																																										
844.00	15.67	H	0.9	0.0	14.78	38.5	-23.7																																																																																										
Rev. 3.17.11																																																																																																	
Note: For Band 13/17 ERP limit is 34.77dBm; For Band 26 limit is 50dBm																																																																																																	

Band LTE5 10MHz QPSK	High Frequency Substitution Measurement UL Verification Services, Inc. Chamber C																																																																																																						
	Company:		Samsung																																																																																																				
	Project #:		14I19248																																																																																																				
	Date:		11/03/14																																																																																																				
	Test Engineer:		R. Alegre																																																																																																				
	Configuration:		X-pos EUT Only (1987514)																																																																																																				
	Mode:		LTE5 10MHz QPSK																																																																																																				
	Test Equipment:		Receiving: Sunol T185, and Chamber C N-type Cable Substitution: Dipole T273, 4ft SMA Cable Warehouse.																																																																																																				
	<table border="1"> <thead> <tr> <th>f MHz</th> <th>SG reading (dBm)</th> <th>Ant. Pol. (H/V)</th> <th>Cable Loss (dB)</th> <th>Antenna Gain (dBd)</th> <th>ERP (dBm)</th> <th>Limit (dBm)</th> <th>Margin (dB)</th> <th>Notes</th> </tr> </thead> <tbody> <tr> <td colspan="10">Low Ch</td> </tr> <tr> <td>829.00</td> <td>6.30</td> <td>V</td> <td>0.9</td> <td>0.0</td> <td>5.40</td> <td>38.5</td> <td>-33.0</td> <td></td> </tr> <tr> <td>829.00</td> <td>15.75</td> <td>H</td> <td>0.9</td> <td>0.0</td> <td>14.85</td> <td>38.5</td> <td>-23.6</td> <td></td> </tr> <tr> <td colspan="10">Mid Ch</td> </tr> <tr> <td>836.50</td> <td>6.77</td> <td>V</td> <td>0.9</td> <td>0.0</td> <td>5.88</td> <td>38.5</td> <td>-32.6</td> <td></td> </tr> <tr> <td>836.50</td> <td>16.28</td> <td>H</td> <td>0.9</td> <td>0.0</td> <td>15.38</td> <td>38.5</td> <td>-23.1</td> <td></td> </tr> <tr> <td colspan="10">High Ch</td> </tr> <tr> <td>844.00</td> <td>6.84</td> <td>V</td> <td>0.9</td> <td>0.0</td> <td>5.94</td> <td>38.5</td> <td>-32.5</td> <td></td> </tr> <tr> <td>844.00</td> <td>16.74</td> <td>H</td> <td>0.9</td> <td>0.0</td> <td>15.85</td> <td>38.5</td> <td>-22.6</td> <td></td> </tr> </tbody> </table>										f MHz	SG reading (dBm)	Ant. Pol. (H/V)	Cable Loss (dB)	Antenna Gain (dBd)	ERP (dBm)	Limit (dBm)	Margin (dB)	Notes	Low Ch										829.00	6.30	V	0.9	0.0	5.40	38.5	-33.0		829.00	15.75	H	0.9	0.0	14.85	38.5	-23.6		Mid Ch										836.50	6.77	V	0.9	0.0	5.88	38.5	-32.6		836.50	16.28	H	0.9	0.0	15.38	38.5	-23.1		High Ch										844.00	6.84	V	0.9	0.0	5.94	38.5	-32.5		844.00	16.74	H	0.9	0.0	15.85	38.5	-22.6	
	f MHz	SG reading (dBm)	Ant. Pol. (H/V)	Cable Loss (dB)	Antenna Gain (dBd)	ERP (dBm)	Limit (dBm)	Margin (dB)	Notes																																																																																														
Low Ch																																																																																																							
829.00	6.30	V	0.9	0.0	5.40	38.5	-33.0																																																																																																
829.00	15.75	H	0.9	0.0	14.85	38.5	-23.6																																																																																																
Mid Ch																																																																																																							
836.50	6.77	V	0.9	0.0	5.88	38.5	-32.6																																																																																																
836.50	16.28	H	0.9	0.0	15.38	38.5	-23.1																																																																																																
High Ch																																																																																																							
844.00	6.84	V	0.9	0.0	5.94	38.5	-32.5																																																																																																
844.00	16.74	H	0.9	0.0	15.85	38.5	-22.6																																																																																																
Rev. 3.17.11 Note: For Band 13/17 ERP limit is 34.77dBm; For Band 26 limit is 50dBm																																																																																																							

Band LTE5 5MHz QPSK	High Frequency Substitution Measurement UL Verification Services, Inc. Chamber C								
	Company:		Samsung						
	Project #:		14I19248						
	Date:		11/03/14						
	Test Engineer:		R. Alegre						
	Configuration:		X-pos EUT Only (1987514)						
	Mode:		LTE5 5MHz QPSK						
	Test Equipment:		Receiving: Sunol T185, and Chamber C N-type Cable Substitution: Dipole T273, 4ft SMA Cable Warehouse.						
	f MHz	SG reading (dBm)	Ant. Pol. (H/V)	Cable Loss (dB)	Antenna Gain (dBd)	ERP (dBm)	Limit (dBm)	Margin (dB)	Notes
	Low Ch								
826.50	6.69	V	0.9	0.0	5.79	38.5	-32.7		
826.50	16.06	H	0.9	0.0	15.16	38.5	-23.3		
Mid Ch									
836.50	6.54	V	0.9	0.0	5.65	38.5	-32.8		
836.50	16.17	H	0.9	0.0	15.27	38.5	-23.2		
High Ch									
846.50	5.70	V	0.9	0.0	4.80	38.5	-33.6		
846.50	15.69	H	0.9	0.0	14.80	38.5	-23.7		
Rev. 3.17.11 Note: For Band 13/17 ERP limit is 34.77dBm; For Band 26 limit is 50dBm									

Band LTE5 3MHz 16QAM	High Frequency Substitution Measurement UL Verification Services, Inc. Chamber C																																																																																																						
	Company:		Samsung																																																																																																				
	Project #:		14I19248																																																																																																				
	Date:		11/03/14																																																																																																				
	Test Engineer:		R. Alegre																																																																																																				
	Configuration:		X-pos EUT Only (1987514)																																																																																																				
	Mode:		LTE5 3MHz 16QAM																																																																																																				
	Test Equipment:		Receiving: Sunol T185, and Chamber C N-type Cable Substitution: Dipole T273, 4ft SMA Cable Warehouse.																																																																																																				
	<table border="1"> <thead> <tr> <th>f MHz</th> <th>SG reading (dBm)</th> <th>Ant. Pol. (H/V)</th> <th>Cable Loss (dB)</th> <th>Antenna Gain (dBd)</th> <th>ERP (dBm)</th> <th>Limit (dBm)</th> <th>Margin (dB)</th> <th>Notes</th> </tr> </thead> <tbody> <tr> <td colspan="10">Low Ch</td> </tr> <tr> <td>825.50</td> <td>5.97</td> <td>V</td> <td>0.9</td> <td>0.0</td> <td>5.07</td> <td>38.5</td> <td>-33.4</td> <td></td> </tr> <tr> <td>825.50</td> <td>14.82</td> <td>H</td> <td>0.9</td> <td>0.0</td> <td>13.92</td> <td>38.5</td> <td>-24.5</td> <td></td> </tr> <tr> <td colspan="10">Mid Ch</td> </tr> <tr> <td>836.50</td> <td>5.90</td> <td>V</td> <td>0.9</td> <td>0.0</td> <td>5.01</td> <td>38.5</td> <td>-33.4</td> <td></td> </tr> <tr> <td>836.50</td> <td>15.22</td> <td>H</td> <td>0.9</td> <td>0.0</td> <td>14.32</td> <td>38.5</td> <td>-24.1</td> <td></td> </tr> <tr> <td colspan="10">High Ch</td> </tr> <tr> <td>847.50</td> <td>6.15</td> <td>V</td> <td>0.9</td> <td>0.0</td> <td>5.25</td> <td>38.5</td> <td>-33.2</td> <td></td> </tr> <tr> <td>847.50</td> <td>15.33</td> <td>H</td> <td>0.9</td> <td>0.0</td> <td>14.44</td> <td>38.5</td> <td>-24.0</td> <td></td> </tr> </tbody> </table>										f MHz	SG reading (dBm)	Ant. Pol. (H/V)	Cable Loss (dB)	Antenna Gain (dBd)	ERP (dBm)	Limit (dBm)	Margin (dB)	Notes	Low Ch										825.50	5.97	V	0.9	0.0	5.07	38.5	-33.4		825.50	14.82	H	0.9	0.0	13.92	38.5	-24.5		Mid Ch										836.50	5.90	V	0.9	0.0	5.01	38.5	-33.4		836.50	15.22	H	0.9	0.0	14.32	38.5	-24.1		High Ch										847.50	6.15	V	0.9	0.0	5.25	38.5	-33.2		847.50	15.33	H	0.9	0.0	14.44	38.5	-24.0	
	f MHz	SG reading (dBm)	Ant. Pol. (H/V)	Cable Loss (dB)	Antenna Gain (dBd)	ERP (dBm)	Limit (dBm)	Margin (dB)	Notes																																																																																														
Low Ch																																																																																																							
825.50	5.97	V	0.9	0.0	5.07	38.5	-33.4																																																																																																
825.50	14.82	H	0.9	0.0	13.92	38.5	-24.5																																																																																																
Mid Ch																																																																																																							
836.50	5.90	V	0.9	0.0	5.01	38.5	-33.4																																																																																																
836.50	15.22	H	0.9	0.0	14.32	38.5	-24.1																																																																																																
High Ch																																																																																																							
847.50	6.15	V	0.9	0.0	5.25	38.5	-33.2																																																																																																
847.50	15.33	H	0.9	0.0	14.44	38.5	-24.0																																																																																																
Rev. 3.17.11 Note: For Band 13/17 ERP limit is 34.77dBm; For Band 26 limit is 50dBm																																																																																																							

Band LTE5 3MHz QPSK	High Frequency Substitution Measurement UL Verification Services, Inc. Chamber C																																																																																																						
	Company:		Samsung																																																																																																				
	Project #:		14I19248																																																																																																				
	Date:		11/03/14																																																																																																				
	Test Engineer:		R. Alegre																																																																																																				
	Configuration:		X-pos EUT Only (1987514)																																																																																																				
	Mode:		LTE5 3MHz QPSK																																																																																																				
	Test Equipment:		Receiving: Sunol T185, and Chamber C N-type Cable Substitution: Dipole T273, 4ft SMA Cable Warehouse.																																																																																																				
	<table border="1"> <thead> <tr> <th>f MHz</th> <th>SG reading (dBm)</th> <th>Ant. Pol. (H/V)</th> <th>Cable Loss (dB)</th> <th>Antenna Gain (dBd)</th> <th>ERP (dBm)</th> <th>Limit (dBm)</th> <th>Margin (dB)</th> <th>Notes</th> </tr> </thead> <tbody> <tr> <td colspan="10">Low Ch</td> </tr> <tr> <td>825.50</td> <td>7.13</td> <td>V</td> <td>0.9</td> <td>0.0</td> <td>6.23</td> <td>38.5</td> <td>-32.2</td> <td></td> </tr> <tr> <td>825.50</td> <td>15.67</td> <td>H</td> <td>0.9</td> <td>0.0</td> <td>14.77</td> <td>38.5</td> <td>-23.7</td> <td></td> </tr> <tr> <td colspan="10">Mid Ch</td> </tr> <tr> <td>836.50</td> <td>7.18</td> <td>V</td> <td>0.9</td> <td>0.0</td> <td>6.29</td> <td>38.5</td> <td>-32.2</td> <td></td> </tr> <tr> <td>836.50</td> <td>16.11</td> <td>H</td> <td>0.9</td> <td>0.0</td> <td>15.21</td> <td>38.5</td> <td>-23.2</td> <td></td> </tr> <tr> <td colspan="10">High Ch</td> </tr> <tr> <td>847.50</td> <td>6.97</td> <td>V</td> <td>0.9</td> <td>0.0</td> <td>6.07</td> <td>38.5</td> <td>-32.4</td> <td></td> </tr> <tr> <td>847.50</td> <td>15.80</td> <td>H</td> <td>0.9</td> <td>0.0</td> <td>14.91</td> <td>38.5</td> <td>-23.5</td> <td></td> </tr> </tbody> </table>										f MHz	SG reading (dBm)	Ant. Pol. (H/V)	Cable Loss (dB)	Antenna Gain (dBd)	ERP (dBm)	Limit (dBm)	Margin (dB)	Notes	Low Ch										825.50	7.13	V	0.9	0.0	6.23	38.5	-32.2		825.50	15.67	H	0.9	0.0	14.77	38.5	-23.7		Mid Ch										836.50	7.18	V	0.9	0.0	6.29	38.5	-32.2		836.50	16.11	H	0.9	0.0	15.21	38.5	-23.2		High Ch										847.50	6.97	V	0.9	0.0	6.07	38.5	-32.4		847.50	15.80	H	0.9	0.0	14.91	38.5	-23.5	
	f MHz	SG reading (dBm)	Ant. Pol. (H/V)	Cable Loss (dB)	Antenna Gain (dBd)	ERP (dBm)	Limit (dBm)	Margin (dB)	Notes																																																																																														
Low Ch																																																																																																							
825.50	7.13	V	0.9	0.0	6.23	38.5	-32.2																																																																																																
825.50	15.67	H	0.9	0.0	14.77	38.5	-23.7																																																																																																
Mid Ch																																																																																																							
836.50	7.18	V	0.9	0.0	6.29	38.5	-32.2																																																																																																
836.50	16.11	H	0.9	0.0	15.21	38.5	-23.2																																																																																																
High Ch																																																																																																							
847.50	6.97	V	0.9	0.0	6.07	38.5	-32.4																																																																																																
847.50	15.80	H	0.9	0.0	14.91	38.5	-23.5																																																																																																
Rev. 3.17.11 Note: For Band 13/17 ERP limit is 34.77dBm; For Band 26 limit is 50dBm																																																																																																							

Band LTE5 1.4MHz 16QAM	High Frequency Substitution Measurement UL Verification Services, Inc. Chamber C																																																																																																						
	Company:		Samsung																																																																																																				
	Project #:		14I19248																																																																																																				
	Date:		11/03/14																																																																																																				
	Test Engineer:		R. Alegre																																																																																																				
	Configuration:		X-pos EUT Only (1987514)																																																																																																				
	Mode:		LTE5 1.4MHz 16QAM																																																																																																				
	Test Equipment:		Receiving: Sunol T185, and Chamber C N-type Cable Substitution: Dipole T273, 4ft SMA Cable Warehouse.																																																																																																				
	<table border="1"> <thead> <tr> <th>f MHz</th> <th>SG reading (dBm)</th> <th>Ant. Pol. (H/V)</th> <th>Cable Loss (dB)</th> <th>Antenna Gain (dBd)</th> <th>ERP (dBm)</th> <th>Limit (dBm)</th> <th>Margin (dB)</th> <th>Notes</th> </tr> </thead> <tbody> <tr> <td colspan="10">Low Ch</td> </tr> <tr> <td>824.70</td> <td>7.27</td> <td>V</td> <td>0.9</td> <td>0.0</td> <td>6.37</td> <td>38.5</td> <td>-32.1</td> <td></td> </tr> <tr> <td>824.70</td> <td>14.96</td> <td>H</td> <td>0.9</td> <td>0.0</td> <td>14.06</td> <td>38.5</td> <td>-24.4</td> <td></td> </tr> <tr> <td colspan="10">Mid Ch</td> </tr> <tr> <td>836.50</td> <td>7.09</td> <td>V</td> <td>0.9</td> <td>0.0</td> <td>6.20</td> <td>38.5</td> <td>-32.3</td> <td></td> </tr> <tr> <td>836.50</td> <td>14.95</td> <td>H</td> <td>0.9</td> <td>0.0</td> <td>14.05</td> <td>38.5</td> <td>-24.4</td> <td></td> </tr> <tr> <td colspan="10">High Ch</td> </tr> <tr> <td>848.30</td> <td>6.94</td> <td>V</td> <td>0.9</td> <td>0.0</td> <td>6.04</td> <td>38.5</td> <td>-32.4</td> <td></td> </tr> <tr> <td>848.30</td> <td>15.20</td> <td>H</td> <td>0.9</td> <td>0.0</td> <td>14.31</td> <td>38.5</td> <td>-24.1</td> <td></td> </tr> </tbody> </table>										f MHz	SG reading (dBm)	Ant. Pol. (H/V)	Cable Loss (dB)	Antenna Gain (dBd)	ERP (dBm)	Limit (dBm)	Margin (dB)	Notes	Low Ch										824.70	7.27	V	0.9	0.0	6.37	38.5	-32.1		824.70	14.96	H	0.9	0.0	14.06	38.5	-24.4		Mid Ch										836.50	7.09	V	0.9	0.0	6.20	38.5	-32.3		836.50	14.95	H	0.9	0.0	14.05	38.5	-24.4		High Ch										848.30	6.94	V	0.9	0.0	6.04	38.5	-32.4		848.30	15.20	H	0.9	0.0	14.31	38.5	-24.1	
	f MHz	SG reading (dBm)	Ant. Pol. (H/V)	Cable Loss (dB)	Antenna Gain (dBd)	ERP (dBm)	Limit (dBm)	Margin (dB)	Notes																																																																																														
Low Ch																																																																																																							
824.70	7.27	V	0.9	0.0	6.37	38.5	-32.1																																																																																																
824.70	14.96	H	0.9	0.0	14.06	38.5	-24.4																																																																																																
Mid Ch																																																																																																							
836.50	7.09	V	0.9	0.0	6.20	38.5	-32.3																																																																																																
836.50	14.95	H	0.9	0.0	14.05	38.5	-24.4																																																																																																
High Ch																																																																																																							
848.30	6.94	V	0.9	0.0	6.04	38.5	-32.4																																																																																																
848.30	15.20	H	0.9	0.0	14.31	38.5	-24.1																																																																																																
Rev. 3.17.11 Note: For Band 13/17 ERP limit is 34.77dBm; For Band 26 limit is 50dBm																																																																																																							

Band LTE5 1.4MHz QPSK	High Frequency Substitution Measurement UL Verification Services, Inc. Chamber C																																																																																																						
	Company:		Samsung																																																																																																				
	Project #:		14I19248																																																																																																				
	Date:		11/03/14																																																																																																				
	Test Engineer:		R. Alegre																																																																																																				
	Configuration:		X-pos EUT Only (1987514)																																																																																																				
	Mode:		LTE5 1.4MHz QPSK																																																																																																				
	Test Equipment:		Receiving: Sunol T185, and Chamber C N-type Cable Substitution: Dipole T273, 4ft SMA Cable Warehouse.																																																																																																				
	<table border="1"> <thead> <tr> <th>f MHz</th> <th>SG reading (dBm)</th> <th>Ant. Pol. (H/V)</th> <th>Cable Loss (dB)</th> <th>Antenna Gain (dBd)</th> <th>ERP (dBm)</th> <th>Limit (dBm)</th> <th>Margin (dB)</th> <th>Notes</th> </tr> </thead> <tbody> <tr> <td colspan="10">Low Ch</td> </tr> <tr> <td>824.70</td> <td>7.85</td> <td>V</td> <td>0.9</td> <td>0.0</td> <td>6.95</td> <td>38.5</td> <td>-31.5</td> <td></td> </tr> <tr> <td>824.70</td> <td>15.46</td> <td>H</td> <td>0.9</td> <td>0.0</td> <td>14.56</td> <td>38.5</td> <td>-23.9</td> <td></td> </tr> <tr> <td colspan="10">Mid Ch</td> </tr> <tr> <td>836.50</td> <td>7.82</td> <td>V</td> <td>0.9</td> <td>0.0</td> <td>6.93</td> <td>38.5</td> <td>-31.5</td> <td></td> </tr> <tr> <td>836.50</td> <td>16.45</td> <td>H</td> <td>0.9</td> <td>0.0</td> <td>15.55</td> <td>38.5</td> <td>-22.9</td> <td></td> </tr> <tr> <td colspan="10">High Ch</td> </tr> <tr> <td>848.30</td> <td>7.32</td> <td>V</td> <td>0.9</td> <td>0.0</td> <td>6.42</td> <td>38.5</td> <td>-32.0</td> <td></td> </tr> <tr> <td>848.30</td> <td>16.68</td> <td>H</td> <td>0.9</td> <td>0.0</td> <td>15.79</td> <td>38.5</td> <td>-22.7</td> <td></td> </tr> </tbody> </table>										f MHz	SG reading (dBm)	Ant. Pol. (H/V)	Cable Loss (dB)	Antenna Gain (dBd)	ERP (dBm)	Limit (dBm)	Margin (dB)	Notes	Low Ch										824.70	7.85	V	0.9	0.0	6.95	38.5	-31.5		824.70	15.46	H	0.9	0.0	14.56	38.5	-23.9		Mid Ch										836.50	7.82	V	0.9	0.0	6.93	38.5	-31.5		836.50	16.45	H	0.9	0.0	15.55	38.5	-22.9		High Ch										848.30	7.32	V	0.9	0.0	6.42	38.5	-32.0		848.30	16.68	H	0.9	0.0	15.79	38.5	-22.7	
	f MHz	SG reading (dBm)	Ant. Pol. (H/V)	Cable Loss (dB)	Antenna Gain (dBd)	ERP (dBm)	Limit (dBm)	Margin (dB)	Notes																																																																																														
Low Ch																																																																																																							
824.70	7.85	V	0.9	0.0	6.95	38.5	-31.5																																																																																																
824.70	15.46	H	0.9	0.0	14.56	38.5	-23.9																																																																																																
Mid Ch																																																																																																							
836.50	7.82	V	0.9	0.0	6.93	38.5	-31.5																																																																																																
836.50	16.45	H	0.9	0.0	15.55	38.5	-22.9																																																																																																
High Ch																																																																																																							
848.30	7.32	V	0.9	0.0	6.42	38.5	-32.0																																																																																																
848.30	16.68	H	0.9	0.0	15.79	38.5	-22.7																																																																																																
Rev. 3.17.11 Note: For Band 13/17 ERP limit is 34.77dBm; For Band 26 limit is 50dBm																																																																																																							

11.2. FIELD STRENGTH OF SPURIOUS RADIATION

RULE PART(S)

FCC: §2.1053, §22.917 and §24.238

LIMIT

The power of any emission outside of the authorized operating frequency ranges must be attenuated below the transmitting power (P) by a factor of at least $43 + 10 \log (P)$ dB.

TEST PROCEDURE

For Cellular equipment - Compliance with these rules is based on the use of measurement instrumentation employing a resolution bandwidth of 100 kHz or greater. In the 1 MHz bands immediately outside and adjacent to the frequency block a resolution bandwidth of at least one percent of the emission bandwidth of the fundamental emission of the transmitter may be employed. A narrower resolution bandwidth is permitted in all cases to improve measurement accuracy provided the measured power is integrated over the full required measurement bandwidth (i.e. 100 kHz or 1 percent of emission bandwidth, as specified). The emission bandwidth is defined as the width of the signal between two points, one below the carrier center frequency and one above the carrier center frequency, outside of which all emissions are attenuated at least 26 dB below the transmitter power.

For PCS equipment - Compliance with these rules is based on the use of measurement instrumentation employing a resolution bandwidth of 1 MHz or greater. However, in the 1 MHz bands immediately outside and adjacent to the frequency block a resolution bandwidth of at least one percent of the emission bandwidth of the fundamental emission of the transmitter may be employed. A narrower resolution bandwidth is permitted in all cases to improve measurement accuracy provided the measured power is integrated over the full required measurement bandwidth (i.e. 1 MHz or 1 percent of emission bandwidth, as specified). The emission bandwidth is defined as the width of the signal between two points, one below the carrier center frequency and one above the carrier center frequency, outside of which all emissions are attenuated at least 26 dB below the transmitter power.

MODES TESTED

GSM, WCDMA, and LTE Band 5

RESULTS

11.2.1. SPURIOUS RADIATION DATA

WCDMA

UL Verification Services, Inc. Above 1GHz High Frequency Substitution Measurement										
Company:		Samsung								
Project #:		14I19248								
Date:		10/30/14								
Test Engineer:		D. Sblendorio/ O. Stoelting								
Configuration:		EUT Z-pos w/ AC charger, headset (Sample 1987514)								
Mode:		HSDPA_B2								
Chamber		Pre-amplifier			Filter		Limit			
3m Chamber		T492			Filter 1		Part 24			
f GHz	SG reading (dBm)	Ant. Pol. (H/V)	Distance (m)	Preamp (dB)	Filter (dB)	EIRP (dBm)	Limit (dBm)	Delta (dB)	Notes	
Band										
Low Ch, 1852.4MHz										
3.705	-24.8	V	3.0	35.4	1.0	-59.2	-13.0	-46.2		
5.557	-21.4	V	3.0	34.7	1.0	-55.1	-13.0	-42.1		
7.410	-18.4	V	3.0	34.9	1.0	-52.3	-13.0	-39.3		
Band 2										
3.705	-23.9	H	3.0	35.4	1.0	-58.2	-13.0	-45.2		
5.557	-20.7	H	3.0	34.7	1.0	-54.5	-13.0	-41.5		
7.410	-16.2	H	3.0	34.9	1.0	-50.1	-13.0	-37.1		
HSDPA										
Mid Ch, 1880MHz										
3.760	-24.4	V	3.0	35.3	1.0	-58.7	-13.0	-45.7		
5.640	-21.5	V	3.0	34.7	1.0	-55.3	-13.0	-42.3		
7.520	-18.4	V	3.0	34.9	1.0	-52.3	-13.0	-39.3		
3.760	-25.0	H	3.0	35.3	1.0	-59.4	-13.0	-46.4		
5.640	-21.3	H	3.0	34.7	1.0	-55.0	-13.0	-42.0		
7.520	-16.8	H	3.0	34.9	1.0	-50.7	-13.0	-37.7		
High Ch, 1907.6MHz										
3.815	-24.6	V	3.0	35.3	1.0	-58.8	-13.0	-45.8		
5.723	-18.6	V	3.0	34.7	1.0	-52.4	-13.0	-39.4		
7.630	-17.5	V	3.0	34.9	1.0	-51.4	-13.0	-38.4		
3.815	-22.3	H	3.0	35.3	1.0	-56.6	-13.0	-43.6		
5.723	-18.3	H	3.0	34.7	1.0	-52.1	-13.0	-39.1		
7.630	-16.2	H	3.0	34.9	1.0	-50.2	-13.0	-37.2		
Rev. 03.03.09										
Note: No other emissions were detected above the system noise floor.										

UL Verification Services, Inc. Above 1GHz High Frequency Substitution Measurement									
Company:		Samsung							
Project #:		14119248							
Date:		10/30/14							
Test Engineer:		D. Sblendorio/ O. Stoelting							
Configuration:		EUT Z-pos w/ AC charger, headset (Sample 1987514)							
Mode:		Rel99_B2							
Chamber		Pre-amplifier			Filter		Limit		
3m Chamber		T34 8449B			Filter 1		Part 24		
f GHz	SG reading (dBm)	Ant. Pol. (H/V)	Distance (m)	Preamp (dB)	Filter (dB)	EIRP (dBm)	Limit (dBm)	Delta (dB)	Notes
Band									
Band 2									
REL99									
Low Ch, 1852.4MHz									
3.705	-22.6	V	3.0	35.4	1.0	-57.0	-13.0	-44.0	
5.557	-20.3	V	3.0	34.7	1.0	-54.0	-13.0	-41.0	
7.410	-16.7	V	3.0	34.9	1.0	-50.6	-13.0	-37.6	
3.705	-24.7	H	3.0	35.4	1.0	-59.1	-13.0	-46.1	
5.557	-20.4	H	3.0	34.7	1.0	-54.2	-13.0	-41.2	
7.410	-16.0	H	3.0	34.9	1.0	-50.0	-13.0	-37.0	
Mid Ch, 1880MHz									
3.760	-24.7	V	3.0	35.3	1.0	-59.1	-13.0	-46.1	
5.640	-20.6	V	3.0	34.7	1.0	-54.3	-13.0	-41.3	
7.520	-18.0	V	3.0	34.9	1.0	-52.0	-13.0	-39.0	
3.760	-23.8	H	3.0	35.3	1.0	-58.2	-13.0	-45.2	
5.640	-20.4	H	3.0	34.7	1.0	-54.1	-13.0	-41.1	
7.520	-16.4	H	3.0	34.9	1.0	-50.4	-13.0	-37.4	
High Ch, 1907.6MHz									
3.815	-25.3	V	3.0	35.3	1.0	-59.6	-13.0	-46.6	
5.723	-20.7	V	3.0	34.7	1.0	-54.4	-13.0	-41.4	
7.630	-18.1	V	3.0	34.9	1.0	-52.1	-13.0	-39.1	
3.815	-24.8	H	3.0	35.3	1.0	-59.1	-13.0	-46.1	
5.723	-18.5	H	3.0	34.7	1.0	-52.2	-13.0	-39.2	
7.630	-16.6	H	3.0	34.9	1.0	-50.5	-13.0	-37.5	
Rev. 03.03.09									
Note: No other emissions were detected above the system noise floor.									

UL Verification Services, Inc. Above 1GHz High Frequency Substitution Measurement										
Company:		Samsung								
Project #:		14119248								
Date:		10/30/14								
Test Engineer:		D. Sblendorio/ O. Stoelting								
Configuration:		EUT X-pos w/ AC charger, headset (Sample 1987514)								
Mode:		HSDPA B5								
Chamber		Pre-amplifier			Filter		Limit			
5m Chamber G		T34 8449B			Filter 1		Part 22			
Band	f GHz	SG reading (dBm)	Ant. Pol. (H/V)	Distance (m)	Preamp (dB)	Filter (dB)	EIRP (dBm)	Limit (dBm)	Delta (dB)	Notes
	Low Ch, 826.4MHz									
Band 5	1.653	-32.0	V	3.0	37.4	1.0	-68.4	-13.0	-55.4	
	2.479	-27.4	V	3.0	36.4	1.0	-62.7	-13.0	-49.7	
	3.306	-24.8	V	3.0	35.8	1.0	-59.6	-13.0	-46.6	
HSDPA	1.653	-30.0	H	3.0	37.4	1.0	-66.4	-13.0	-53.4	
	2.479	-29.2	H	3.0	36.4	1.0	-64.6	-13.0	-51.6	
	3.306	-25.0	H	3.0	35.8	1.0	-59.7	-13.0	-46.7	
	Mid Ch, 836.6MHz									
	1.673	-31.2	V	3.0	37.3	1.0	-67.6	-13.0	-54.6	
	2.510	-27.3	V	3.0	36.4	1.0	-62.7	-13.0	-49.7	
	3.346	-24.8	V	3.0	35.8	1.0	-59.6	-13.0	-46.6	
	1.673	-28.2	H	3.0	37.3	1.0	-64.6	-13.0	-51.6	
	2.510	-29.6	H	3.0	36.4	1.0	-65.0	-13.0	-52.0	
	3.346	-25.0	H	3.0	35.8	1.0	-59.8	-13.0	-46.8	
	High Ch, 846.6MHz									
	1.693	-31.5	V	3.0	37.3	1.0	-67.8	-13.0	-54.8	
	2.540	-27.5	V	3.0	36.3	1.0	-62.8	-13.0	-49.8	
	3.386	-25.0	V	3.0	35.7	1.0	-59.7	-13.0	-46.7	
	1.693	-31.3	H	3.0	37.3	1.0	-67.6	-13.0	-54.6	
	2.540	-29.3	H	3.0	36.3	1.0	-64.6	-13.0	-51.6	
	3.386	-25.2	H	3.0	35.7	1.0	-59.9	-13.0	-46.9	
Rev. 03.03.09										
Note: No other emissions were detected above the system noise floor.										

UL Verification Services, Inc.
Above 1GHz High Frequency Substitution Measurement

Company: Samsung
Project #: 14119248
Date: 10/30/14
Test Engineer: D. Sblendorio/ O. Stoelting
Configuration: EUT X-pos w/ AC charger, headset (Sample 1987514)
Mode: REL99 B5

Chamber

5m Chamber G

Pre-amplifier

T34 8449B

Filter

Filter 1

Limit

Part 22

	f GHz	SG reading (dBm)	Ant. Pol. (H/V)	Distance (m)	Preamp (dB)	Filter (dB)	EIRP (dBm)	Limit (dBm)	Delta (dB)	Notes		
Band 5 REL99	Low Ch, 826.4MHz											
		1.653	-30.8	V	3.0	37.4	1.0	-67.1	-13.0	-54.1		
		2.479	-26.3	V	3.0	36.4	1.0	-61.6	-13.0	-48.6		
		3.306	-24.0	V	3.0	35.8	1.0	-58.8	-13.0	-45.8		
		1.653	-29.8	H	3.0	37.4	1.0	-66.2	-13.0	-53.2		
		2.479	-27.9	H	3.0	36.4	1.0	-63.3	-13.0	-50.3		
		3.306	-24.0	H	3.0	35.8	1.0	-58.7	-13.0	-45.7		
		Mid Ch, 836.6MHz										
		1.673	-30.1	V	3.0	37.3	1.0	-66.5	-13.0	-53.5		
		2.510	-26.5	V	3.0	36.4	1.0	-61.8	-13.0	-48.8		
		3.346	-23.6	V	3.0	35.8	1.0	-58.3	-13.0	-45.3		
		1.673	-30.6	H	3.0	37.3	1.0	-66.9	-13.0	-53.9		
	2.510	-29.7	H	3.0	36.4	1.0	-65.0	-13.0	-52.0			
	3.346	-25.0	H	3.0	35.8	1.0	-59.7	-13.0	-46.7			
	High Ch, 846.6MHz											
	1.693	-30.7	V	3.0	37.3	1.0	-67.0	-13.0	-54.0			
	2.540	-26.3	V	3.0	36.3	1.0	-61.7	-13.0	-48.7			
	3.386	-23.9	V	3.0	35.7	1.0	-58.6	-13.0	-45.6			
	1.693	-30.1	H	3.0	37.3	1.0	-66.4	-13.0	-53.4			
	2.540	-29.1	H	3.0	36.3	1.0	-64.5	-13.0	-51.5			
	3.386	-24.2	H	3.0	35.7	1.0	-58.9	-13.0	-45.9			

Rev. 03.03.09
 Note: No other emissions were detected above the system noise floor.

GSM

UL Verification Services, Inc.
Above 1GHz High Frequency Substitution Measurement

Company: Samsung
Project #: 14119248
Date: 10/30/14
Test Engineer: D. Sblendorio/ O. Stoelting
Configuration: EUT Z-pos w/ AC charger, headset (Sample 1987514)
Mode: EGPRS1900

Chamber
3m Chamber

Pre-amplifier
T34 8449B

Filter
Filter 1

Limit
Part 24

Band	f GHz	SG reading (dBm)	Ant. Pol. (H/V)	Distance (m)	Preamp (dB)	Filter (dB)	EIRP (dBm)	Limit (dBm)	Delta (dB)	Notes
	Low Ch, 1850.2MHz									
GSM 1900	3.700	-26.7	V	3.0	35.4	1.0	-61.1	-13.0	-48.1	
	5.551	-15.1	V	3.0	34.7	1.0	-48.8	-13.0	-35.8	
	7.401	-19.1	V	3.0	34.9	1.0	-53.1	-13.0	-40.1	
EGPRS	3.700	-25.9	H	3.0	35.4	1.0	-60.3	-13.0	-47.3	
	5.551	-16.0	H	3.0	34.7	1.0	-49.8	-13.0	-36.8	
	7.401	-17.2	H	3.0	34.9	1.0	-51.1	-13.0	-38.1	
	Mid Ch, 1880.0MHz									
	3.760	-26.1	V	3.0	35.3	1.0	-60.4	-13.0	-47.4	
	5.640	-20.3	V	3.0	34.7	1.0	-54.0	-13.0	-41.0	
	7.520	-19.4	V	3.0	34.9	1.0	-53.3	-13.0	-40.3	
	3.760	-26.7	H	3.0	35.3	1.0	-61.1	-13.0	-48.1	
	5.640	-18.0	H	3.0	34.7	1.0	-51.7	-13.0	-38.7	
	7.520	-18.4	H	3.0	34.9	1.0	-52.3	-13.0	-39.3	
	High Ch, 1909.8MHz									
	3.820	-25.0	V	3.0	35.3	1.0	-59.3	-13.0	-46.3	
	5.729	-21.6	V	3.0	34.7	1.0	-55.4	-13.0	-42.4	
	7.639	-19.2	V	3.0	35.0	1.0	-53.2	-13.0	-40.2	
	3.820	-20.8	H	3.0	35.3	1.0	-55.0	-13.0	-42.0	
	5.729	-17.6	H	3.0	34.7	1.0	-51.4	-13.0	-38.4	
	7.639	-16.9	H	3.0	35.0	1.0	-50.9	-13.0	-37.9	

Rev. 03.03.09
 Note: No other emissions were detected above the system noise floor.

UL Verification Services, Inc. Above 1GHz High Frequency Substitution Measurement										
Company:		Samsung								
Project #:		14119248								
Date:		10/30/14								
Test Engineer:		D. Sblendorio/ O. Stoelting								
Configuration:		EUT Z-pos w/ AC charger, headset (Sample 1987514)								
Mode:		GPRS1900								
Chamber		Pre-amplifier			Filter		Limit			
3m Chamber		T34 8449B			Filter 1		Part 24			
Band	f GHz	SG reading (dBm)	Ant. Pol. (H/V)	Distance (m)	Preamp (dB)	Filter (dB)	EIRP (dBm)	Limit (dBm)	Delta (dB)	Notes
Low Ch, 1850.2MHz										
GSM	3.700	-26.5	V	3.0	35.4	1.0	-60.9	-13.0	-47.9	
	5.551	-10.3	V	3.0	34.7	1.0	-44.1	-13.0	-31.1	
	7.401	-19.5	V	3.0	34.9	1.0	-53.4	-13.0	-40.4	
1900	3.700	-23.8	H	3.0	35.4	1.0	-58.2	-13.0	-45.2	
	5.551	-12.6	H	3.0	34.7	1.0	-46.3	-13.0	-33.3	
	7.401	-18.2	H	3.0	34.9	1.0	-52.1	-13.0	-39.1	
Mid Ch, 1880.0MHz										
GPRS	3.760	-26.2	V	3.0	35.3	1.0	-60.6	-13.0	-47.6	
	5.640	-9.6	V	3.0	34.7	1.0	-43.3	-13.0	-30.3	
	7.520	-16.6	V	3.0	34.9	1.0	-50.5	-13.0	-37.5	
	3.760	-26.5	H	3.0	35.3	1.0	-60.9	-13.0	-47.9	
	5.640	-19.5	H	3.0	34.7	1.0	-53.2	-13.0	-40.2	
	7.520	-17.5	H	3.0	34.9	1.0	-51.5	-13.0	-38.5	
High Ch, 1909.8MHz										
	3.820	-26.1	V	3.0	35.3	1.0	-60.4	-13.0	-47.4	
	5.729	-18.2	V	3.0	34.7	1.0	-52.0	-13.0	-39.0	
	7.639	-19.1	V	3.0	35.0	1.0	-53.0	-13.0	-40.0	
	3.820	-22.3	H	3.0	35.3	1.0	-56.6	-13.0	-43.6	
	5.729	-9.6	H	3.0	34.7	1.0	-43.4	-13.0	-30.4	
	7.639	-16.4	H	3.0	35.0	1.0	-50.4	-13.0	-37.4	
Rev. 03.03.09										
Note: No other emissions were detected above the system noise floor.										

UL Verification Services, Inc. Above 1GHz High Frequency Substitution Measurement										
Company:		Samsung								
Project #:		14119248								
Date:		10/30/14								
Test Engineer:		D. Sblendorio/ O. Stoelting								
Configuration:		EUT X-pos w/ AC charger, headset (Sample 1987514)								
Mode:		EGPRS850								
Chamber		Pre-amplifier		Filter		Limit				
3m Chamber		T34 8449B		Filter 1		Part 22				
Band	f GHz	SG reading (dBm)	Ant. Pol. (H/V)	Distance (m)	Preamp (dB)	Filter (dB)	EIRP (dBm)	Limit (dBm)	Delta (dB)	Notes
	Low Ch, 824.2MHz									
	1.648	-22.7	V	3.0	37.4	1.0	-59.1	-13.0	-46.1	
GSM	2.473	-18.2	V	3.0	36.4	1.0	-53.6	-13.0	-40.6	
850	3.297	-16.1	V	3.0	35.8	1.0	-50.9	-13.0	-37.9	
	1.648	-19.2	H	3.0	37.4	1.0	-55.6	-13.0	-42.6	
	2.473	-18.3	H	3.0	36.4	1.0	-53.7	-13.0	-40.7	
EGPRS	3.297	-16.1	H	3.0	35.8	1.0	-50.9	-13.0	-37.9	
	Mid Ch, 836.6MHz									
	1.673	-21.0	V	3.0	37.3	1.0	-57.3	-13.0	-44.3	
	2.510	-18.4	V	3.0	36.4	1.0	-53.8	-13.0	-40.8	
	3.346	-15.7	V	3.0	35.8	1.0	-50.4	-13.0	-37.4	
	1.673	-18.9	H	3.0	37.3	1.0	-55.3	-13.0	-42.3	
	2.510	-18.2	H	3.0	36.4	1.0	-53.6	-13.0	-40.6	
	3.346	-16.2	H	3.0	35.8	1.0	-51.0	-13.0	-38.0	
	High Ch, 848.8MHz									
	1.698	-20.1	V	3.0	37.3	1.0	-56.4	-13.0	-43.4	
	2.546	-18.2	V	3.0	36.3	1.0	-53.5	-13.0	-40.5	
	3.395	-15.8	V	3.0	35.7	1.0	-50.5	-13.0	-37.5	
	1.698	-24.1	H	3.0	37.3	1.0	-60.4	-13.0	-47.4	
	2.546	-18.3	H	3.0	36.3	1.0	-53.6	-13.0	-40.6	
	3.395	-15.7	H	3.0	35.7	1.0	-50.4	-13.0	-37.4	
Rev. 03.03.09										
Note: No other emissions were detected above the system noise floor.										

UL Verification Services, Inc. Above 1GHz High Frequency Substitution Measurement										
Company:		Samsung								
Project #:		14119248								
Date:		10/30/14								
Test Engineer:		D. Sblendorio/ O. Stoelting								
Configuration:		EUT X-pos w/ AC charger, headset (Sample 1987514)								
Mode:		GPRS850								
Chamber		Pre-amplifier		Filter		Limit				
3m Chamber		T34 8449B		Filter 1		Part 22				
Band	f GHz	SG reading (dBm)	Ant. Pol. (H/V)	Distance (m)	Preamp (dB)	Filter (dB)	EIRP (dBm)	Limit (dBm)	Delta (dB)	Notes
	Low Ch, 824.2MHz									
	1.648	-11.6	V	3.0	37.4	1.0	-48.0	-13.0	-35.0	
GSM	2.473	-11.0	V	3.0	36.4	1.0	-46.4	-13.0	-33.4	
850	3.297	-16.4	V	3.0	35.8	1.0	-51.2	-13.0	-38.2	
	1.648	-9.2	H	3.0	37.4	1.0	-45.6	-13.0	-32.6	
	2.473	-15.9	H	3.0	36.4	1.0	-51.3	-13.0	-38.3	
GPRS	3.297	-16.6	H	3.0	35.8	1.0	-51.4	-13.0	-38.4	
	Mid Ch, 836.6MHz									
	1.673	-11.5	V	3.0	37.3	1.0	-47.8	-13.0	-34.8	
	2.510	-16.2	V	3.0	36.4	1.0	-51.6	-13.0	-38.6	
	3.346	-16.0	V	3.0	35.8	1.0	-50.7	-13.0	-37.7	
	1.673	-12.9	H	3.0	37.3	1.0	-49.3	-13.0	-36.3	
	2.510	-17.7	H	3.0	36.4	1.0	-53.1	-13.0	-40.1	
	3.346	-16.4	H	3.0	35.8	1.0	-51.1	-13.0	-38.1	
	High Ch, 848.8MHz									
	1.698	-20.5	V	3.0	37.3	1.0	-56.8	-13.0	-43.8	
	2.546	-17.7	V	3.0	36.3	1.0	-53.0	-13.0	-40.0	
	3.395	-15.4	V	3.0	35.7	1.0	-50.1	-13.0	-37.1	
	1.698	-8.1	H	3.0	37.3	1.0	-44.4	-13.0	-31.4	
	2.546	-18.4	H	3.0	36.3	1.0	-53.8	-13.0	-40.8	
	3.395	-16.4	H	3.0	35.7	1.0	-51.1	-13.0	-38.1	
Rev. 03.03.09										
Note: No other emissions were detected above the system noise floor.										

LTE Band 5

UL Verification Services, Inc. Above 1GHz High Frequency Substitution Measurement										
Company:		Samsung								
Project #:		14I19248								
Date:		10/31/14								
Test Engineer:		J. Hsu								
Configuration:		EUT/ AC Charger/ Headset								
Mode:		TX, LTE band 5, 10MHz BW, 16QAM								
Chamber		Pre-amplifier		Filter		Limit				
5m Chamber B		T34 8449B		Filter 1		Part 22				
Band	f GHz	SG reading (dBm)	Ant. Pol. (H/V)	Distance (m)	Preamp (dB)	Filter (dB)	EIRP (dBm)	Limit (dBm)	Delta (dB)	Notes
LTE5 10MHz 16QAM	Low Ch, 829MHz									
	1.658	-26.3	V	3.0	37.4	1.0	-62.7	-13.0	-49.7	
	2.487	-22.4	V	3.0	36.4	1.0	-57.7	-13.0	-44.7	
	3.316	-21.1	V	3.0	35.8	1.0	-55.9	-13.0	-42.9	
	1.658	-25.9	H	3.0	37.4	1.0	-62.3	-13.0	-49.3	
	2.487	-22.1	H	3.0	36.4	1.0	-57.4	-13.0	-44.4	
	3.316	-21.1	H	3.0	35.8	1.0	-55.8	-13.0	-42.8	
	Mid Ch, 836.5MHz									
	1.673	-26.4	V	3.0	37.3	1.0	-62.8	-13.0	-49.8	
	2.510	-20.8	V	3.0	36.4	1.0	-56.2	-13.0	-43.2	
	3.346	-21.1	V	3.0	35.8	1.0	-55.9	-13.0	-42.9	
	1.673	-23.6	H	3.0	37.3	1.0	-60.0	-13.0	-47.0	
2.510	-23.4	H	3.0	36.4	1.0	-58.8	-13.0	-45.8		
3.346	-22.1	H	3.0	35.8	1.0	-56.8	-13.0	-43.8		
High Ch, 844MHz										
1.688	-25.8	V	3.0	37.3	1.0	-62.1	-13.0	-49.1		
2.532	-23.0	V	3.0	36.3	1.0	-58.3	-13.0	-45.3		
3.376	-20.7	V	3.0	35.7	1.0	-55.4	-13.0	-42.4		
1.688	-26.9	H	3.0	37.3	1.0	-63.3	-13.0	-50.3		
2.532	-24.2	H	3.0	36.3	1.0	-59.5	-13.0	-46.5		
3.376	-21.2	H	3.0	35.7	1.0	-55.9	-13.0	-42.9		
Rev. 03.03.09										
Note: No other emissions were detected above the system noise floor.										

UL Verification Services, Inc.
Above 1GHz High Frequency Substitution Measurement

Company: Samsung
Project #: 14119248
Date: 10/31/14
Test Engineer: J. Hsu
Configuration: EUT/ AC Charger/ Headset
Mode: TX, LTE band 5, 10MHz BW, QPSK

Chamber	Pre-amplifier	Filter	Limit
5m Chamber B	T34 8449B	Filter 1	Part 22

Band

f GHz	SG reading (dBm)	Ant. Pol. (H/V)	Distance (m)	Preamp (dB)	Filter (dB)	EIRP (dBm)	Limit (dBm)	Delta (dB)	Notes
Low Ch, 829MHz									
1.658	-26.2	V	3.0	37.4	1.0	-62.6	-13.0	-49.6	
2.487	-22.1	V	3.0	36.4	1.0	-57.5	-13.0	-44.5	
10MHz									
3.316	-21.6	V	3.0	35.8	1.0	-56.3	-13.0	-43.3	
1.658	-25.9	H	3.0	37.4	1.0	-62.2	-13.0	-49.2	
QPSK									
2.487	-23.6	H	3.0	36.4	1.0	-59.0	-13.0	-46.0	
3.316	-21.5	H	3.0	35.8	1.0	-56.3	-13.0	-43.3	
Mid Ch, 836.5MHz									
1.673	-25.8	V	3.0	37.3	1.0	-62.1	-13.0	-49.1	
2.510	-21.5	V	3.0	36.4	1.0	-56.9	-13.0	-43.9	
3.346	-21.2	V	3.0	35.8	1.0	-55.9	-13.0	-42.9	
1.673	-23.8	H	3.0	37.3	1.0	-60.1	-13.0	-47.1	
2.510	-24.2	H	3.0	36.4	1.0	-59.5	-13.0	-46.5	
3.346	-20.6	H	3.0	35.8	1.0	-55.3	-13.0	-42.3	
High Ch, 844MHz									
1.688	-25.4	V	3.0	37.3	1.0	-61.7	-13.0	-48.7	
2.532	-22.6	V	3.0	36.3	1.0	-57.9	-13.0	-44.9	
3.376	-20.3	V	3.0	35.7	1.0	-55.0	-13.0	-42.0	
1.688	-26.9	H	3.0	37.3	1.0	-63.2	-13.0	-50.2	
2.532	-24.0	H	3.0	36.3	1.0	-59.3	-13.0	-46.3	
3.376	-20.3	H	3.0	35.7	1.0	-55.0	-13.0	-42.0	

Rev. 03.03.09

Note: No other emissions were detected above the system noise floor.

UL Verification Services, Inc. Above 1GHz High Frequency Substitution Measurement																	
Company:		Samsung															
Project #:		14I19248															
Date:		10/31/14															
Test Engineer:		J. Hsu															
Configuration:		EUT/ AC Charger/ Headset															
Mode:		TX, LTE band 5, 5MHz BW, 16QAM															
<table border="1" style="width: 100%; border-collapse: collapse; margin: 10px 0;"> <tr> <td style="width: 25%; text-align: center;">Chamber</td> <td style="width: 25%; text-align: center;">Pre-amplifier</td> <td style="width: 25%; text-align: center;">Filter</td> <td style="width: 25%; text-align: center;">Limit</td> </tr> <tr> <td style="text-align: center;">5m Chamber B</td> <td style="text-align: center;">T34 8449B</td> <td style="text-align: center;">Filter 1</td> <td style="text-align: center;">Part 22</td> </tr> </table>										Chamber	Pre-amplifier	Filter	Limit	5m Chamber B	T34 8449B	Filter 1	Part 22
Chamber	Pre-amplifier	Filter	Limit														
5m Chamber B	T34 8449B	Filter 1	Part 22														
Band	f GHz	SG reading (dBm)	Ant. Pol. (H/V)	Distance (m)	Preamp (dB)	Filter (dB)	EIRP (dBm)	Limit (dBm)	Delta (dB)	Notes							
Low Ch, 826.5MHz																	
LTE5	1.653	-28.6	V	3.0	37.4	1.0	-65.0	-13.0	-52.0								
	2.480	-23.4	V	3.0	36.4	1.0	-58.8	-13.0	-45.8								
5MHz	3.306	-22.5	V	3.0	35.8	1.0	-57.3	-13.0	-44.3								
	1.653	-26.8	H	3.0	37.4	1.0	-63.2	-13.0	-50.2								
16QAM	2.480	-25.7	H	3.0	36.4	1.0	-61.0	-13.0	-48.0								
	3.306	-22.6	H	3.0	35.8	1.0	-57.4	-13.0	-44.4								
Mid Ch, 836.5MHz																	
	1.673	-27.1	V	3.0	37.3	1.0	-63.4	-13.0	-50.4								
	2.510	-23.8	V	3.0	36.4	1.0	-59.2	-13.0	-46.2								
	3.346	-22.3	V	3.0	35.8	1.0	-57.0	-13.0	-44.0								
	1.673	-23.6	H	3.0	37.3	1.0	-60.0	-13.0	-47.0								
	2.510	-23.4	H	3.0	36.4	1.0	-58.8	-13.0	-45.8								
	3.346	-20.0	H	3.0	35.8	1.0	-54.7	-13.0	-41.7								
High Ch, 846.5MHz																	
	1.693	-28.4	V	3.0	37.3	1.0	-64.7	-13.0	-51.7								
	2.540	-24.1	V	3.0	36.3	1.0	-59.5	-13.0	-46.5								
	3.386	-22.2	V	3.0	35.7	1.0	-56.9	-13.0	-43.9								
	1.693	-27.0	H	3.0	37.3	1.0	-63.3	-13.0	-50.3								
	2.540	-25.7	H	3.0	36.3	1.0	-61.0	-13.0	-48.0								
	3.386	-22.0	H	3.0	35.7	1.0	-56.7	-13.0	-43.7								
Rev. 03.03.09																	
Note: No other emissions were detected above the system noise floor.																	

UL Verification Services, Inc. Above 1GHz High Frequency Substitution Measurement										
Company:		Samsung								
Project #:		14I19248								
Date:		10/31/14								
Test Engineer:		J. Hsu								
Configuration:		EUT/ AC Charger/ Headset								
Mode:		TX, LTE band 5, 5MHz BW, QPSK								
<div style="display: flex; justify-content: space-around; margin-top: 10px;"> <div style="border: 1px solid black; padding: 2px; background-color: #e0f2f1;">Chamber</div> <div style="border: 1px solid black; padding: 2px; background-color: #e0f2f1;">Pre-amplifier</div> <div style="border: 1px solid black; padding: 2px; background-color: #e0f2f1;">Filter</div> <div style="border: 1px solid black; padding: 2px; background-color: #e0f2f1;">Limit</div> </div> <div style="display: flex; justify-content: space-around; margin-top: 5px;"> <div style="border: 1px solid black; padding: 2px; background-color: #e0f2f1;">5m Chamber B</div> <div style="border: 1px solid black; padding: 2px; background-color: #e0f2f1;">T34 8449B</div> <div style="border: 1px solid black; padding: 2px; background-color: #e0f2f1;">Filter 1</div> <div style="border: 1px solid black; padding: 2px; background-color: #e0f2f1;">Part 22</div> </div>										
Band	f GHz	SG reading (dBm)	Ant. Pol. (H/V)	Distance (m)	Preamp (dB)	Filter (dB)	EIRP (dBm)	Limit (dBm)	Delta (dB)	Notes
	Low Ch, 826.5MHz									
	1.653	-28.4	V	3.0	37.4	1.0	-64.8	-13.0	-51.8	
	2.480	-24.5	V	3.0	36.4	1.0	-59.9	-13.0	-46.9	
5MHz	3.306	-22.5	V	3.0	35.8	1.0	-57.3	-13.0	-44.3	
	1.653	-26.5	H	3.0	37.4	1.0	-62.8	-13.0	-49.8	
	2.480	-24.5	H	3.0	36.4	1.0	-59.9	-13.0	-46.9	
QPSK	3.306	-22.4	H	3.0	35.8	1.0	-57.2	-13.0	-44.2	
	Mid Ch, 836.5MHz									
	1.673	-27.0	V	3.0	37.3	1.0	-63.4	-13.0	-50.4	
	2.510	-24.6	V	3.0	36.4	1.0	-59.9	-13.0	-46.9	
	3.346	-22.4	V	3.0	35.8	1.0	-57.1	-13.0	-44.1	
	1.673	-23.1	H	3.0	37.3	1.0	-59.4	-13.0	-46.4	
	2.510	-23.3	H	3.0	36.4	1.0	-58.7	-13.0	-45.7	
	3.346	-20.2	H	3.0	35.8	1.0	-55.0	-13.0	-42.0	
	High Ch, 846.5MHz									
	1.693	-28.1	V	3.0	37.3	1.0	-64.4	-13.0	-51.4	
	2.540	-24.5	V	3.0	36.3	1.0	-59.9	-13.0	-46.9	
	3.386	-22.0	V	3.0	35.7	1.0	-56.7	-13.0	-43.7	
	1.693	-27.5	H	3.0	37.3	1.0	-63.8	-13.0	-50.8	
	2.540	-26.1	H	3.0	36.3	1.0	-61.5	-13.0	-48.5	
	3.386	-22.4	H	3.0	35.7	1.0	-57.1	-13.0	-44.1	
Rev. 03.03.09										
Note: No other emissions were detected above the system noise floor.										

UL Verification Services, Inc. Above 1GHz High Frequency Substitution Measurement										
Company:		Samsung								
Project #:		14I19248								
Date:		10/31/14								
Test Engineer:		J. Hsu								
Configuration:		EUT/ AC Charger/ Headset								
Mode:		TX, LTE band 5, 3MHz BW, 16QAM								
Chamber		Pre-amplifier			Filter		Limit			
5m Chamber B		T34 8449B			Filter 1		Part 22			
Band	f GHz	SG reading (dBm)	Ant. Pol. (H/V)	Distance (m)	Preamp (dB)	Filter (dB)	EIRP (dBm)	Limit (dBm)	Delta (dB)	Notes
	Low Ch, 825.5MHz									
	1.651	-26.8	V	3.0	37.4	1.0	-63.2	-13.0	-50.2	
	2.477	-23.7	V	3.0	36.4	1.0	-59.0	-13.0	-46.0	
3MHz	3.302	-21.7	V	3.0	35.8	1.0	-56.5	-13.0	-43.5	
	1.651	-27.5	H	3.0	37.4	1.0	-63.9	-13.0	-50.9	
16QAM	2.477	-26.3	H	3.0	36.4	1.0	-61.7	-13.0	-48.7	
	3.302	-22.0	H	3.0	35.8	1.0	-56.8	-13.0	-43.8	
	Mid Ch, 836.5MHz									
	1.673	-25.7	V	3.0	37.3	1.0	-62.1	-13.0	-49.1	
	2.510	-23.5	V	3.0	36.4	1.0	-58.8	-13.0	-45.8	
	3.346	-22.0	V	3.0	35.8	1.0	-56.8	-13.0	-43.8	
	1.673	-26.7	H	3.0	37.3	1.0	-63.1	-13.0	-50.1	
	2.510	-25.7	H	3.0	36.4	1.0	-61.0	-13.0	-48.0	
	3.346	-21.9	H	3.0	35.8	1.0	-56.7	-13.0	-43.7	
	High Ch, 847.5MHz									
	1.695	-27.2	V	3.0	37.3	1.0	-63.5	-13.0	-50.5	
	2.543	-24.0	V	3.0	36.3	1.0	-59.4	-13.0	-46.4	
	3.390	-21.6	V	3.0	35.7	1.0	-56.3	-13.0	-43.3	
	1.695	-27.0	H	3.0	37.3	1.0	-63.3	-13.0	-50.3	
	2.543	-25.1	H	3.0	36.3	1.0	-60.4	-13.0	-47.4	
	3.390	-21.9	H	3.0	35.7	1.0	-56.6	-13.0	-43.6	
Rev. 03.03.09										
Note: No other emissions were detected above the system noise floor.										

UL Verification Services, Inc. Above 1GHz High Frequency Substitution Measurement																	
Company:		Samsung															
Project #:		14119248															
Date:		10/31/14															
Test Engineer:		J. Hsu															
Configuration:		EUT/ AC Charger/ Headset															
Mode:		TX, LTE band 5, 3MHz BW, QPSK															
<table border="1" style="width: 100%; border-collapse: collapse; margin: 10px 0;"> <tr> <td style="width: 25%; text-align: center;">Chamber</td> <td style="width: 25%; text-align: center;">Pre-amplifier</td> <td style="width: 25%; text-align: center;">Filter</td> <td style="width: 25%; text-align: center;">Limit</td> </tr> <tr> <td style="text-align: center;">5m Chamber B</td> <td style="text-align: center;">T34 8449B</td> <td style="text-align: center;">Filter 1</td> <td style="text-align: center;">Part 22</td> </tr> </table>										Chamber	Pre-amplifier	Filter	Limit	5m Chamber B	T34 8449B	Filter 1	Part 22
Chamber	Pre-amplifier	Filter	Limit														
5m Chamber B	T34 8449B	Filter 1	Part 22														
Band	f GHz	SG reading (dBm)	Ant. Pol. (H/V)	Distance (m)	Preamp (dB)	Filter (dB)	EIRP (dBm)	Limit (dBm)	Delta (dB)	Notes							
Low Ch, 825.5MHz																	
	1.651	-27.3	V	3.0	37.4	1.0	-63.7	-13.0	-50.7								
	2.477	-24.0	V	3.0	36.4	1.0	-59.4	-13.0	-46.4								
3MHz	3.302	-21.9	V	3.0	35.8	1.0	-56.7	-13.0	-43.7								
	1.651	-26.8	H	3.0	37.4	1.0	-63.2	-13.0	-50.2								
QPSK	2.477	-25.4	H	3.0	36.4	1.0	-60.8	-13.0	-47.8								
	3.302	-21.9	H	3.0	35.8	1.0	-56.7	-13.0	-43.7								
Mid Ch, 836.5MHz																	
	1.673	-26.3	V	3.0	37.3	1.0	-62.7	-13.0	-49.7								
	2.510	-23.6	V	3.0	36.4	1.0	-59.0	-13.0	-46.0								
	3.346	-22.5	V	3.0	35.8	1.0	-57.2	-13.0	-44.2								
	1.673	-26.2	H	3.0	37.3	1.0	-62.6	-13.0	-49.6								
	2.510	-25.1	H	3.0	36.4	1.0	-60.4	-13.0	-47.4								
	3.346	-22.1	H	3.0	35.8	1.0	-56.8	-13.0	-43.8								
High Ch, 847.5MHz																	
	1.695	-27.1	V	3.0	37.3	1.0	-63.4	-13.0	-50.4								
	2.543	-22.8	V	3.0	36.3	1.0	-58.2	-13.0	-45.2								
	3.390	-21.3	V	3.0	35.7	1.0	-56.0	-13.0	-43.0								
	1.695	-26.7	H	3.0	37.3	1.0	-63.0	-13.0	-50.0								
	2.543	-24.9	H	3.0	36.3	1.0	-60.3	-13.0	-47.3								
	3.390	-20.6	H	3.0	35.7	1.0	-55.3	-13.0	-42.3								
Rev. 03.03.09																	
Note: No other emissions were detected above the system noise floor.																	

UL Verification Services, Inc. Above 1GHz High Frequency Substitution Measurement										
Company:		Samsung								
Project #:		14I19248								
Date:		10/31/14								
Test Engineer:		J. Hsu								
Configuration:		EUT/ AC Charger/ Headset								
Mode:		TX, LTE band 5, 1.4MHz BW, 16QAM								
Chamber		Pre-amplifier		Filter		Limit				
5m Chamber B		T34 8449B		Filter 1		Part 22				
Band	f GHz	SG reading (dBm)	Ant. Pol. (H/V)	Distance (m)	Preamp (dB)	Filter (dB)	EIRP (dBm)	Limit (dBm)	Delta (dB)	Notes
LTE5 1.4MHz 16QAM	Low Ch, 824.7MHz									
	1.649	-24.2	V	3.0	37.4	1.0	-60.6	-13.0	-47.6	
	2.474	-19.6	V	3.0	36.4	1.0	-55.0	-13.0	-42.0	
	3.299	-21.6	V	3.0	35.8	1.0	-56.4	-13.0	-43.4	
	1.649	-22.7	H	3.0	37.4	1.0	-59.0	-13.0	-46.0	
	2.474	-19.6	H	3.0	36.4	1.0	-55.0	-13.0	-42.0	
	3.299	-21.7	H	3.0	35.8	1.0	-56.5	-13.0	-43.5	
	Mid Ch, 836.5MHz									
	1.673	-25.2	V	3.0	37.3	1.0	-61.5	-13.0	-48.5	
	2.510	-17.9	V	3.0	36.4	1.0	-53.3	-13.0	-40.3	
	3.346	-21.1	V	3.0	35.8	1.0	-55.8	-13.0	-42.8	
	1.673	-20.8	H	3.0	37.3	1.0	-57.1	-13.0	-44.1	
	2.510	-25.4	H	3.0	36.4	1.0	-60.8	-13.0	-47.8	
	3.346	-21.8	H	3.0	35.8	1.0	-56.6	-13.0	-43.6	
	High Ch, 848.3MHz									
	1.697	-25.7	V	3.0	37.3	1.0	-62.1	-13.0	-49.1	
	2.545	-18.1	V	3.0	36.3	1.0	-53.5	-13.0	-40.5	
	3.393	-21.1	V	3.0	35.7	1.0	-55.8	-13.0	-42.8	
1.697	-26.5	H	3.0	37.3	1.0	-62.8	-13.0	-49.8		
2.545	-25.6	H	3.0	36.3	1.0	-60.9	-13.0	-47.9		
3.393	-21.7	H	3.0	35.7	1.0	-56.4	-13.0	-43.4		
Rev. 03.03.09										
Note: No other emissions were detected above the system noise floor.										

UL Verification Services, Inc. Above 1GHz High Frequency Substitution Measurement										
Company:		Samsung								
Project #:		14I19248								
Date:		10/31/14								
Test Engineer:		J. Hsu								
Configuration:		EUT/ AC Charger/ Headset								
Mode:		TX, LTE band 5, 1.4MHz BW, QPSK								
Chamber		Pre-amplifier			Filter		Limit			
5m Chamber B		T34 8449B			Filter 1		Part 22			
Band	f GHz	SG reading (dBm)	Ant. Pol. (H/V)	Distance (m)	Preamp (dB)	Filter (dB)	EIRP (dBm)	Limit (dBm)	Delta (dB)	Notes
	Low Ch, 824.7MHz									
	1.649	-24.2	V	3.0	37.4	1.0	-60.6	-13.0	-47.6	
	2.474	-19.5	V	3.0	36.4	1.0	-54.9	-13.0	-41.9	
1.4MHz	3.299	-21.4	V	3.0	35.8	1.0	-56.2	-13.0	-43.2	
	1.649	-22.4	H	3.0	37.4	1.0	-58.8	-13.0	-45.8	
	2.474	-19.1	H	3.0	36.4	1.0	-54.5	-13.0	-41.5	
QPSK	3.299	-21.9	H	3.0	35.8	1.0	-56.7	-13.0	-43.7	
	Mid Ch, 836.5MHz									
	1.673	-24.9	V	3.0	37.3	1.0	-61.3	-13.0	-48.3	
	2.510	-17.7	V	3.0	36.4	1.0	-53.0	-13.0	-40.0	
	3.346	-21.5	V	3.0	35.8	1.0	-56.2	-13.0	-43.2	
	1.673	-20.5	H	3.0	37.3	1.0	-56.8	-13.0	-43.8	
	2.510	-25.4	H	3.0	36.4	1.0	-60.8	-13.0	-47.8	
	3.346	-21.9	H	3.0	35.8	1.0	-56.7	-13.0	-43.7	
	High Ch, 848.3MHz									
	1.697	-25.7	V	3.0	37.3	1.0	-62.0	-13.0	-49.0	
	2.545	-19.2	V	3.0	36.3	1.0	-54.6	-13.0	-41.6	
	3.393	-21.5	V	3.0	35.7	1.0	-56.2	-13.0	-43.2	
	1.697	-25.6	H	3.0	37.3	1.0	-61.9	-13.0	-48.9	
	2.545	-22.0	H	3.0	36.3	1.0	-57.4	-13.0	-44.4	
	3.393	-21.2	H	3.0	35.7	1.0	-56.0	-13.0	-43.0	
Rev. 03.03.09										
Note: No other emissions were detected above the system noise floor.										