

TEST REPORT

Report Number: 14938215 - E1V3

Applicant : SAMSUNG ELECTRONICS CO., LTD.
129, SAMSUNG-RO, YEONGTONG-GU
SUWON-SI, GYEONGGI-DO, 16677, KOREA

Model : SM-A256E/DSN

FCC ID : A3LSMA256E

EUT Description : GSM/WCDMA/LTE Phone with BT/BLE, DTS/UNII a/b/g/n/ac

Test Standard(s) : FCC CFR47 PART 22 SUBPART H
FCC CFR47 PART 24 SUBPART E
FCC CFR47 PART 27 SUBPART F, H, L, and M
FCC CFR47 PART 90 SUBPART S

Date Of Issue:

2023-11-09

Prepared by:

UL VERIFICATION SERVICES

47173 Benicia Street

Fremont, CA 94538 U.S.A.

TEL: (510) 319-4000

FAX: (510) 661-0888



Revision History

<u>Rev.</u>	<u>Issue Date</u>	<u>Revisions</u>	<u>Revised By</u>
V1	2023-10-27	Initial Issue	
V2	2023-11-08	Updated Selection 1,2,3,6,8	Eric Ting
V3	2023-11-09	Updated Selection 6.2	Eric Ting

TABLE OF CONTENTS

1. ATTESTATION OF TEST RESULTS	7
2. SUMMARY OF TEST RESULTS	8
3. TEST METHODOLOGY	9
4. FACILITIES AND ACCREDITATION	9
5. CALIBRATION AND UNCERTAINTY	10
5.1. MEASURING INSTRUMENT CALIBRATION	10
5.2. SAMPLE CALCULATION	10
5.3. MEASUREMENT UNCERTAINTY	10
6. EQUIPMENT UNDER TEST	11
6.1. DESCRIPTION OF EUT	11
6.2. MAXIMUM OUTPUT POWER	12
6.3. SOFTWARE AND FIRMWARE	18
6.4. MAXIMUM ANTENNA GAIN	18
6.5. WORST-CASE CONFIGURATION AND MODE	19
6.6. DESCRIPTION OF TEST SETUP	20
7. TEST AND MEASUREMENT EQUIPMENT	22
8. RF OUTPUT POWER VERIFICATION	23
8.1. GSM	23
8.1.1. GSM 850	24
8.1.2. GSM 1900	25
8.2. WCDMA	26
8.2.1. WCDMA BAND 5	28
8.2.2. WCDMA BAND 2	29
8.2.3. WCDMA BAND 4	30
8.3. LTE CONDUCTED OUTPUT POWER MEASUREMENT PROCEDURE	31
8.3.1. LTE BAND 2	32
8.3.2. LTE BAND 12	35
8.3.3. LTE BAND 13	37
8.3.4. LTE BAND 26 (FCC Part 90S)	38
8.3.5. LTE BAND 26 (FCC Part 22)	41
8.3.6. LTE BAND 41	44
8.3.7. LTE BAND 66	46

9. CONDUCTED TEST RESULTS 49

9.1. OCCUPIED BANDWIDTH 49

9.1.1. GSM 54

9.1.2. WCDMA 55

9.1.3. LTE BAND 2 56

9.1.4. LTE BAND 12 56

9.1.5. LTE BAND 13 56

9.1.6. LTE BAND 26 (FCC PART 90S) 57

9.1.7. LTE BAND 26 (FCC PART 22) 57

9.1.8. LTE BAND 41 57

9.1.9. LTE BAND 66 58

9.2. BAND EDGE AND EMISSION MASK 59

9.2.1. GSM 850 60

9.2.2. GSM 1900 61

9.2.3. WCDMA BAND 5 62

9.2.4. WCDMA BAND 2 63

9.2.5. WCDMA BAND 4 64

9.2.6. LTE BAND 2 BANDEDGE 65

9.2.7. LTE BAND 12 ADJACENT CHANNEL POWER 74

9.2.8. LTE BAND 13 ADJACENT CHANNEL POWER 87

9.2.9. LTE BAND 26 EMISSION MASK (FCC PART 90S) 91

9.2.10. LTE BAND 26 BANDEDGE (FCC PART 22) 98

9.2.11. LTE BAND 41 ADJACENT CHANNEL POWER 105

9.2.12. LTE BAND 66 BANDEDGE 118

9.3. OUT OF BAND EMISSIONS 127

9.3.1. GSM 850 128

9.3.2. GSM 1900 130

9.3.3. WCDMA BAND 5 132

9.3.4. WCDMA BAND 2 134

9.3.5. WCDMA BAND 4 136

9.3.6. LTE BAND 2 138

9.3.7. LTE BAND 12 145

9.3.8. LTE BAND 13 150

9.3.9. LTE BAND 26 (FCC PART 90S) 152

9.3.10. LTE BAND 26 (FCC PART 22) 156

9.3.11.	LTE BAND 41	162
9.3.12.	LTE BAND 66	167
9.4.	FREQUENCY STABILITY	174
9.4.1.	GSM	175
9.4.2.	WCDMA	177
9.4.3.	LTE BAND 2.....	180
9.4.4.	LTE BAND 12.....	181
9.4.5.	LTE BAND 13.....	182
9.4.6.	LTE BAND 26.....	183
9.4.7.	LTE BAND 41.....	184
9.4.8.	LTE BAND 66.....	185
9.5.	PEAK-TO-AVERAGE POWER RATIO	186
9.5.1.	GSM.....	187
9.5.2.	WCDMA	188
9.5.3.	LTE BAND 2.....	189
9.5.4.	LTE BAND 12.....	191
9.5.5.	LTE BAND 13.....	193
9.5.6.	LTE BAND 26 (FCC PART 90S)	194
9.5.7.	LTE BAND 26 (FCC PART 22).....	196
9.5.8.	LTE BAND 41.....	198
9.5.9.	LTE BAND 66.....	200
10.	RADIATED TEST RESULTS.....	203
10.1.	EFFECTIVE RADIATED POWER ERP/EIRP.....	203
10.1.1.	GSM	212
10.1.2.	WCDMA.....	213
10.1.3.	LTE Band 2.....	215
10.1.4.	LTE Band 12.....	217
10.1.5.	LTE Band 13.....	219
10.1.6.	LTE Band 26 (FCC PART 90S)	220
10.1.7.	LTE Band 26 (FCC PART 22).....	222
10.1.8.	LTE Band 41.....	224
10.1.9.	LTE Band 66.....	226
10.2.	FIELD STRENGTH OF SPURIOUS RADIATION	229
10.2.1.	GSM 850	230
10.2.2.	GSM 1900	239

10.2.3.	WCDMA BAND 5	248
10.2.4.	WCDMA BAND 2	257
10.2.5.	WCDMA BAND 4	266
10.2.6.	LTE BAND 2	275
10.2.7.	LTE BAND 12	284
10.2.8.	LTE BAND 13	293
10.2.9.	LTE BAND 26 (FCC PART 90S)	298
10.2.10.	LTE BAND 26 (FCC PART 22)	303
10.2.11.	LTE BAND 41	312
10.2.12.	LTE BAND 66	321
11.	SETUP PHOTOS	330



1. ATTESTATION OF TEST RESULTS

Applicant Name and Address	SAMSUNG ELECTRONICS CO., LTD. 129, SAMSUNG-RO, YEONGTONG-GU SUWON-SI, GYEONGGI-DO, 16677, KOREA
Model	SM-A256E/DSN
FCC ID	A3LSMA256E
EUT Description	GSM/WCDMA/LTE PHONE WITH BT/BLE, DTS/UNII A/B/G/N/AC
Serial Number	Conducted: R3CW50B7JLN Radiated: R3CW70X5MRF, R3CW70X5MQD
Date Tested	9/13/2023 – 10/20/2023
Applicable Standards	FCC 47 CFR PART 22H, 24E, 27F,H,L, M and PART 90S
Test Results	COMPLIES

UL Verification Services Inc. tested the above equipment in accordance with the requirements set forth in the above standards. The test results show that the equipment tested is capable of demonstrating compliance with the requirements as documented in this report.

The results documented in this report apply only to the tested sample, under the conditions and modes of operation as described herein. It is the manufacturer's responsibility to assure that additional production units of this model are manufactured with identical electrical and mechanical components. All samples tested were in good operating condition throughout the entire test program. Measurement Uncertainties are published for informational purposes only and were not taken into account unless noted otherwise.

This document may not be altered or revised in any way unless done so by UL Verification Services Inc and all revisions are duly noted in the revisions section. Any alteration of this document not carried out by UL Verification Services Inc will constitute fraud and shall nullify the document. This report must not be used by the client to claim product certification, approval, or endorsement by A2LA, NIST, any agency of the Federal Government, or any agency of the U.S. government.

Approved & Released By: 	Reviewed By: 	Prepared By: 
Dan Corona Operations Leader UL Verification Services Inc.	Kiya Kedida Senior Project Engineer UL Verification Services Inc.	Eric Ting Senior Test Engineer UL Verification Services Inc.

2. SUMMARY OF TEST RESULTS

This report contains data provided by the customer which can impact the validity of results. UL Verification Services Inc is only responsible for the validity of results after the integration of the data provided by the customer.

Requirement Description	Requirement Clause Number (FCC)	Result	Remarks
RF Conducted Output Power	2.1046 , 90.635 (b)	Complies	
Effective Radiated Power	22.913 (a)(5)	Complies	
	27.50 (c) (10)	Complies	
	27.50 (b) (10)	Complies	
Equivalent Isotropic Radiated Power	24.232 (c)	Complies	
	27.50 (d) (4)	Complies	
	27.50 (d) (4)	Complies	
	-	Complies	
	27.50 (a) (3)	Complies	
	27.50 (h) (2)	Complies	
	27.50 (c) (10)	Complies	
Occupied Bandwidth	2.1049	Complies	
Band Edge and Emission Mask	2.1051, 22.917 (a), 24.238 (a), 27.53 (h), 27.53 (m)(4) & (m) (6), 27.53 (g), 27.53 (c) (f), 27.53(a), 27.53(l), 90.543 (e)(f), 90.691 (a),	Complies	
Out of Band Emissions	2.1051, 22.917 (a), 24.238 (a), 27.53 (h), 27.53 (m)(4) & (m) (6), 27.53 (g), 27.53 (c) (f), 27.53(a), 27.53(l), 90.543 (e)(f), 90.691 (a)	Complies	
Frequency Stability	2.1055, 22.355, 24.235, 27.54, 90.539, 90.213	Complies	
Peak-to-Average Ratio	22.913 (d), 24.232 (d), 27.50 (d) (5), 27.50 (j) (4)	Complies	
Field Strength of Spurious Radiation	2.1053, 22.917 (a), 24.238 (a), 27.53 (h), 27.53 (m)(4) & (m) (6), 27.53 (g), 27.53 (c) (f), 27.53(a), 27.53(l), 90.543 (e)(f), 90.691 (a)	Complies	

3. TEST METHODOLOGY

The tests documented in this report were performed in accordance with the following:

- ANSI C63.26:2015
- TIA-603-E
- FCC 47 CFR Part 2, Part 22, Part 24, Part 27 and Part 90S
- [FCC KDB 971168 D01 v03r01](#): Power Meas License Digital Systems
- [FCC KDB 971168 D02 v02r02](#): Misc Rev Approv License Devices
- [FCC KDB 412172 D01 v01r01](#): Determining ERP and EIRP

4. FACILITIES AND ACCREDITATION

UL Verification Services Inc. is accredited by A2LA, Certificate Number 0751.05, for all testing performed within the scope of this report. Testing was performed at the locations noted below.

	Address	ISED CABID	ISED Company Number	FCC Registration
<input type="checkbox"/>	Building 1: 47173 Benicia Street, Fremont, CA 94538 USA	US0104	2324A	550739
<input checked="" type="checkbox"/>	Building 2: 47266 Benicia Street, Fremont, CA 94538 USA			
<input checked="" type="checkbox"/>	Building 3: 843 Auburn Court, Fremont, CA 94538 USA			
<input checked="" type="checkbox"/>	Building 4: 47658 Kato Rd, Fremont, CA 94538 USA			
<input type="checkbox"/>	Building 5: 47670 Kato Rd, Fremont, CA 94538 USA			

5. CALIBRATION AND UNCERTAINTY

5.1. MEASURING INSTRUMENT CALIBRATION

The measuring equipment utilized to perform the tests documented in this report has been calibrated in accordance with the manufacturer's recommendations, and is traceable to recognized national standards.

5.2. SAMPLE CALCULATION

RADIATED EMISSIONS

Where relevant, the following sample calculation is provided:

- a) $E \text{ (dB}\mu\text{V/m)} = \text{Measured amplitude level (dB}\mu\text{V)} + \text{Cable Loss (dB)} + \text{Antenna Factor (dB/m)}$.
- b) $E \text{ (dB}\mu\text{V/m)} = \text{Measured amplitude level (dBm)} + 107 + \text{Cable Loss (dB)} + \text{Antenna Factor (dB/m)}$.
- c) $E \text{ (dB}\mu\text{V/m)} = \text{EIRP (dBm)} - 20\log(D) + 104.8$; where D is the measurement distance (in the far field region) in m.
- d) $\text{EIRP (dBm)} = E \text{ (dB}\mu\text{V/m)} + 20\log(D) - 104.8$; where D is the measurement distance (in the far field region) in m.

So, from d), The measuring distance is usually at 3m, then $20 * \log(3) = 9.5424$
 Then, $\text{EIRP (dBm)} = E \text{ (dB}\mu\text{V/m)} + 9.5424 - 104.8 = E \text{ (dB}\mu\text{V/m)} - 95.2576$

5.3. MEASUREMENT UNCERTAINTY

Where relevant, the following measurement uncertainty levels have been estimated for tests performed on the apparatus:

PARAMETER	U _{LAB}
Conducted Antenna Port Emission Measurement	1.94 dB
Power Spectral Density	2.466 dB
Time Domain Measurements Using SA	3.39 dB
RF Power Measurement Direct Method Using Power Meter	0.450 dB (Peak) 1.3 dB (Average)
Radio Frequency (Spectrum Analyzer)	141.16 Hz
Occupied Bandwidth	1.2%
Worst Case Conducted Disturbance, 9KHz to 0.15 MHz	3.78 dB
Worst Case Conducted Disturbance, 0.15 to 30 MHz	3.40 dB
Worst Case Radiated Disturbance, 9KHz to 30 MHz	2.87 dB
Worst Case Radiated Disturbance, 30 to 1000 MHz	6.01 dB
Worst Case Radiated Disturbance, 1000 to 18000 MHz	4.73 dB
Worst Case Radiated Disturbance, 18000 to 26000 MHz	4.51 dB
Worst Case Radiated Disturbance, 26000 to 40000 MHz	5.29 dB
Temperature	±0.57 %
Relative Humidity	3.39 %

Uncertainty figures are valid to a confidence level of 95%.

6. EQUIPMENT UNDER TEST

6.1. DESCRIPTION OF EUT

The EUT is a GSM/WCDMA/LTE Phone with BT/BLE, DTS/UNII a/b/g/n/ac.

The model SM-A256E/DSN was used for final testing and is representative of the test results in this report.

6.2. MAXIMUM OUTPUT POWER

ERP/EIRP LIMIT

FCC: §2.1046, §22.913, §24.232, §27.50, §90.635, §90.541

EIRP/ERP TEST PROCEDURE

ANSI C63.26:2015
KDB 971168 D01 Section 5.8
KDB 412172 D01

$ERP/EIRP = P_{Meas} + GT - LC$

where: ERP/EIRP = effective or equivalent radiated power, respectively (expressed in the same units as P_{Meas} , typically dBW or dBm);

P_{Meas} = measured transmitter output power or PSD, in dBm or dBW;

GT = gain of the transmitting antenna, in dBd (ERP) or dBi (EIRP);

LC = signal attenuation in the connecting cable between the transmitter and antenna, in dB.

For devices utilizing multiple antennas, KDB 662911 provides guidance for determining the effective array transmit antenna gain term to be used in the above equation.

The transmitter has a maximum average radiated ERP / EIRP output powers as follows:

GSM MODES

Part 22 850MHz					
Frequency range (MHz)	Modulation	Radiated ERP		99% BW (kHz)	Emission Designator
		Average (dBm)	Average (W)		
824.2-848.8	GPRS	28.10	0.6457	247.27	247KGXW
	EGPRS	28.00	0.6310	248.28	248KG7W
Part 24 1900MHz					
Frequency range (MHz)	Modulation	Radiated EIRP		99% BW (kHz)	Emission Designator
		Average (dBm)	Average (W)		
1850.2-1909.8	GPRS	24.12	0.2582	245.87	246KGXW
	EGPRS	23.56	0.2270	241.83	242KG7W

WCDMA MODES

Part 22 Band 5					
Frequency range (MHz)	Modulation	Radiated ERP		99% BW (kHz)	Emission Designator
		Average (dBm)	Average (W)		
826.4-846.6	REL 99	17.33	0.0541	4180	4M18F9W
	HSDPA	14.68	0.0294	4182	4M18F9W
Part 24 Band 2					
Frequency range (MHz)	Modulation	Radiated EIRP		99% BW (kHz)	Emission Designator
		Average (dBm)	Average (W)		
1852.4-1907.6	REL 99	16.90	0.0490	4175	4M17F9W
	HSDPA	14.20	0.0263	4177	4M18F9W
Part 27 Band 4					
Frequency range (MHz)	Modulation	Radiated EIRP		99% BW (kHz)	Emission Designator
		Average (dBm)	Average (W)		
1712.4-1752.6	REL 99	17.07	0.0509	4179	4M18F9W
	HSDPA	16.41	0.0438	4190	4M19F9W

LTE BAND 2

Part 24							
Bandwidth (MHz)	Modulation	Low Frequency (MHz)	Upper Frequency (MHz)	Radiated EIRP		99% BW (kHz)	Emission Designator
				Average (dBm)	Average (W)		
1.4	QPSK	1850.7	1909.3	24.76	0.2992	1090	1M09G7W
	16QAM			24.15	0.2600	1094	1M09D7W
3.0	QPSK	1851.5	1908.5	26.13	0.4102	2709	2M71G7W
	16QAM			25.28	0.3373	2702	2M70D7W
5.0	QPSK	1852.5	1907.5	24.45	0.2786	4512	4M51G7W
	16QAM			23.42	0.2198	4513	4M51D7W
10.0	QPSK	1855.0	1905.0	23.47	0.2223	9012	9M01G7W
	16QAM			23.19	0.2084	8997	9M00D7W
15.0	QPSK	1857.5	1902.5	25.57	0.3606	13447	13M4G7W
	16QAM			24.68	0.2938	13444	13M4D7W
20.0	QPSK	1860.0	1900.0	23.47	0.2223	17902	17M9G7W
	16QAM			23.24	0.2109	17911	17M9D7W

LTE BAND 12

Part 27							
Bandwidth (MHz)	Modulation	Low Frequency (MHz)	Upper Frequency (MHz)	Radiated ERP		99% BW (kHz)	Emission Designator
				Average (dBm)	Average (W)		
1.4	QPSK	699.7	715.3	20.92	0.1236	1090	1M09G7W
	16QAM			19.79	0.0953	1094	1M09D7W
3.0	QPSK	700.5	714.5	20.55	0.1135	2707	2M71G7W
	16QAM			19.55	0.0902	2707	2M71D7W
5.0	QPSK	701.5	713.5	20.48	0.1117	4498	4M50G7W
	16QAM			19.48	0.0887	4503	4M50D7W
10.0	QPSK	704.0	711.0	20.69	0.1172	8948	8M95G7W
	16QAM			19.03	0.0800	8943	8M94D7W

LTE BAND 13

Part 27							
Bandwidth (MHz)	Modulation	Low Frequency (MHz)	Upper Frequency (MHz)	Radiated ERP		99% BW (kHz)	Emission Designator
				Average (dBm)	Average (W)		
5.0	QPSK	779.5	784.5	20.62	0.1153	4518	4M52G7W
	16QAM			19.65	0.0923	4518	4M52D7W
10.0	QPSK	782.0	782.0	19.99	0.0998	9052	9M05G7W
	16QAM			19.65	0.0923	9025	9M03D7W

LTE BAND 26 (FCC Part 90S)

Part 90S							
Bandwidth (MHz)	Modulation	Low Frequency (MHz)	Upper Frequency (MHz)	Conducted Average (dBm)	Conducted Average (W)	99% BW (kHz)	Emission Designator
				1.4	QPSK		
	16QAM	23.50	0.2239	1089	1M09D7W		
3.0	QPSK	815.5	822.5	23.80	0.2399	2707	2M71G7W
				16QAM	23.40	0.2188	2707
5.0	QPSK	816.5	821.5	23.70	0.2344	4518	4M52G7W
				16QAM	23.20	0.2089	4515
10.0	QPSK	819.0	819.0	23.60	0.2291	9020	9M02G7W
				16QAM	23.40	0.2188	9020
15.0	QPSK	821.5	821.5	23.60	0.2291	13485	13M5G7W
				16QAM	22.80	0.1905	13393

LTE BAND 26 (FCC Part 22)

Part 22							
Bandwidth (MHz)	Modulation	Low Frequency (MHz)	Upper Frequency (MHz)	Radiated ERP		99% BW (kHz)	Emission Designator
				Average (dBm)	Average (W)		
1.4	QPSK	824.7	848.3	17.77	0.0598	1096	1M10G7W
	16QAM			17.36	0.0545	1090	1M09D7W
3.0	QPSK	825.5	847.5	17.84	0.0608	2702	2M70G7W
	16QAM			17.44	0.0555	2698	2M70D7W
5.0	QPSK	826.5	846.5	17.83	0.0607	4528	4M53G7W
	16QAM			17.42	0.0552	4512	4M51D7W
10.0	QPSK	829.0	844.0	16.39	0.0436	9041	9M04G7W
	16QAM			15.96	0.0394	9025	9M02D7W
15.0	QPSK	831.5	841.5	16.42	0.0439	13516	13M5G7W
	16QAM			15.96	0.0394	13499	13M5D7W

LTE BAND 41

Part 27							
Bandwidth (MHz)	Modulation	Low Frequency (MHz)	Upper Frequency (MHz)	Radiated EIRP		99% BW (kHz)	Emission Designator
				Average (dBm)	Average (W)		
5.0	QPSK	2498.5	2687.5	20.93	0.1239	4502	4M50G7W
	16QAM			19.59	0.0910	4519	4M52D7W
10.0	QPSK	2501.0	2685.0	21.11	0.1291	8998	9M00G7W
	16QAM			19.14	0.0820	8973	8M97D7W
15.0	QPSK	2503.5	2682.5	20.37	0.1089	13417	13M4G7W
	16QAM			19.66	0.0925	13418	13M4D7W
20.0	QPSK	2506.0	2680.0	19.41	0.0873	17914	17M9G7W
	16QAM			19.36	0.0863	17899	17M9D7W

LTE BAND 66

Part 27							
Bandwidth (MHz)	Modulation	Low Frequency (MHz)	Upper Frequency (MHz)	Radiated EIRP		99% BW (kHz)	Emission Designator
				Average (dBm)	Average (W)		
1.4	QPSK	1710.7	1779.3	20.19	0.1045	1090	1M09G7W
	16QAM			20.08	0.1019	1091	1M09D7W
3.0	QPSK	1711.5	1778.5	20.63	0.1156	2701	2M70G7W
	16QAM			20.32	0.1076	2693	2M69D7W
5.0	QPSK	1712.5	1777.5	20.85	0.1216	4504	4M50G7W
	16QAM			20.39	0.1094	4508	4M51D7W
10.0	QPSK	1715.0	1775.0	21.35	0.1365	8983	8M98G7W
	16QAM			21.05	0.1274	8977	8M98D7W
15.0	QPSK	1717.5	1772.5	21.78	0.1507	13422	13M4G7W
	16QAM			21.32	0.1355	13449	13M4D7W
20.0	QPSK	1720.0	1770.0	22.19	0.1656	17914	17M9G7W
	16QAM			22.08	0.1614	17915	17M9D7W

6.3. SOFTWARE AND FIRMWARE

The test utility software used during testing was A145M.001.

6.4. MAXIMUM ANTENNA GAIN

The antenna(s) gain and type, as provided by the manufacturer' are as follows:

The radio utilizes a MFA antenna, with a maximum gain as follows:

Bands	Antenna	Antenna Gain (dBi)
GSM850, 824-849MHz	A	-4.42
GSM1900, 1850-1910MHz	B	0.30
WCDMA Band 2, 1850-1910 MHz	B	0.30
WCDMA Band 4, 1710-1755 MHz	B	-0.77
WCDMA Band 5, 824-849 MHz	A	-4.42
LTE Band 2, 1850 – 1910 MHz	B	0.30
LTE Band 2, 1850 – 1910 MHz	E	-2.14
LTE Band 12, 699 – 716 MHz	A	-4.16
LTE Band 13, 777 – 787 MHz	A	-5.05
LTE Band 26 PT90, 814 – 824 MHz	A	-4.36
LTE Band 26 PT22 , 824 – 849 MHz	A	-4.36
LTE Band 41, 2496 – 2690 MHz	B	1.31
LTE Band 66, 1710 – 1780 MHz	B	-0.58
LTE Band 66, 1710 – 1780 MHz	E	-3.74

6.5. WORST-CASE CONFIGURATION AND MODE

The EUT supports LTE:

Band 2, Band 4, Band 5, Band 12, Band 13, Band 17, Band 26, Band 41 and Band 66.

For LTE Bands the worst-case scenario for all measurements is based on the average conducted output power measurement investigation results. Output power measurements were measured on QPSK and 16QAM modulations. All testing was performed using QPSK, and 16QAM modulations to represent the worst case.

The fundamental of the EUT was investigated in three orthogonal orientations X, Y, & Z. It was determined that X-Axis for 2500 MHz And X-Axis for 700, 850, and Y-Axis for 1700 and 1900 MHz with AC/DC Adapter was worst-case orientation.

All radios that can be transmitted simultaneously have been evaluated for radiated for all possible combinations of transmission and found to be in compliance.

Radiated spurious emissions were investigated below 30MHz, 30MHz-1GHz, and above 1GHz. There were no emissions found below 30MHz and 30MHz-1GHz.

LTE Band 4 (1710-1755MHz, 1.4/3/5/10/15/20MHz bandwidth) is covered by LTE Band 66 (1710 -1780 MHz). Because it is a subset of LTE band 66 and they have same output power and channel bandwidth.

LTE Band 5 (824-849MHz, 1.4/3/5/10/15MHz bandwidth) are covered by LTE Band 26 (814-849MHz).). Because it is a subset of LTE band 26 and they have same output power and channel bandwidth.

LTE Band 17 (704 - 716 MHz, 5/10 MHz bandwidth) is covered by LTE Band 12 (699 - 716 MHz). Because it is a subset of LTE band 12 and they have same output power and channel bandwidth.

Antenna E LTE Band 2 (1850-1910MHz, 1.4/3/5/10/15/20MHz bandwidth) is covered by the Antenna B because Antenna E has the same or lower output power, same channel bandwidth, and lower peak antenna gain than that of Antenna B.

Antenna E LTE Band 4 (1710-1755MHz, 1.4/3/5/10/15/20MHz bandwidth) and Antenna B LTE Band 4 (1710 - 1755 MHz) is covered by the Antenna B because Antenna E has the same or lower output power, channel bandwidth, and lower peak antenna gain than that of Antenna B.

Antenna E LTE Band 66 (1710-1780MHz, 1.4/3/5/10/15/20MHz bandwidth) and Antenna B LTE Band 66 (1710 -1780 MHz) is covered by the Antenna B because Antenna E has the same or lower output power, channel bandwidth, and lower peak antenna gain than that of Antenna B.

6.6. DESCRIPTION OF TEST SETUP

SUPPORT TEST EQUIPMENT						
Description	Manufacturer	Model	Serial Number	FCC ID		
AC Adapter	Samsung	EP-TA800	R37MAMT21J2SE3	N/A		
I/O CABLES (RF CONDUCTED TEST)						
Cable No.	Port	# of Identical Ports	Connector Type	Cable Type	Cable Length (m)	Remarks
1	RF Out	1	Spectrum Analyzer	Shielded	None	N/A
2	Antenna Port	1	EUT	Shielded	0.1m	N/A
3	RF In/Out	1	Communication Test Set	Shielded	1m	N/A
I/O CABLES (RF RADIATED TEST)						
Cable No.	Port	# of Identical Ports	Connector Type	Cable Type	Cable Length (m)	Remarks
1	USB	1	USB	Shielded	1	N/A

CONDUCTED SETUP

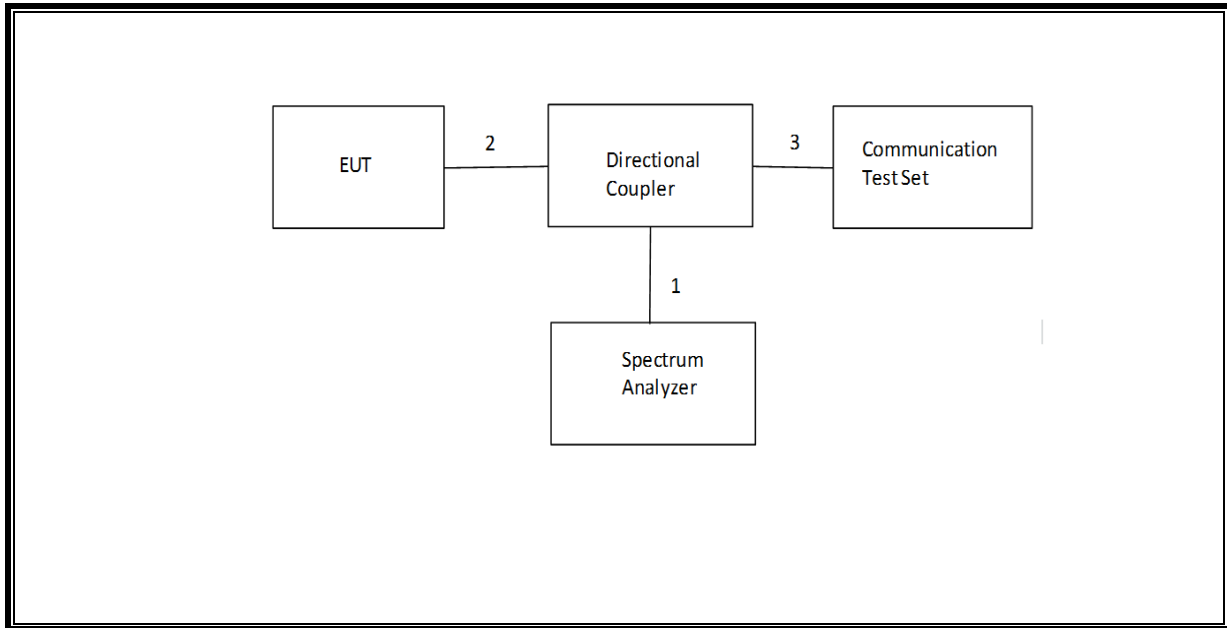

RADIATED SETUP

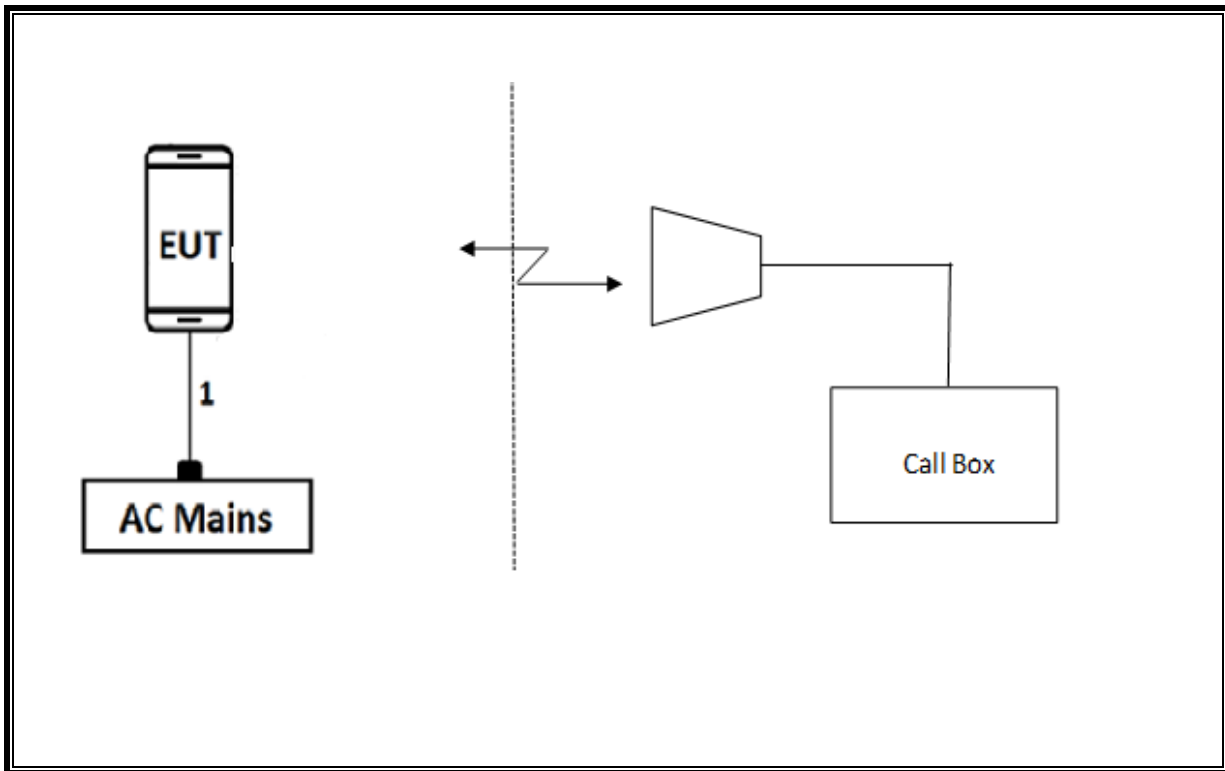

7. TEST AND MEASUREMENT EQUIPMENT

The following test and measurement equipment was utilized for the tests documented in this report:

TEST EQUIPMENT LIST					
Description	Manufacturer	Model	ID Num	Cal Due	Last Cal
Spectrum Analyzer, PXA, 3Hz to 44GHz	Keysight Technologies Inc	N9030A	85313	7/31/2024	7/31/2023
Wideband Communication Test Set, Call Box	Rohde & Schwarz	CMW500	222797	5/31/2024	5/9/2023
Antenna, Horn 1-18GHz	ETS-Lindgren (Cedar Park, Texas)	3117	200897	3/31/2024	3/7/2023
RF Filter Box, 1-18GHz, 12 Port.	UL-FR1	Frankenstein	231874	8/30/2024	8/23/2023
EMI TEST RECEIVER	Rohde & Schwarz	ESW44	PRE0179372	2/29/2024	2/17/2023
Antenna, Horn 1-18GHz	ETS-Lindgren (Cedar Park, Texas)	3117	230300	1/12/2024	1/12/2023
RF Filter Box, 1-18GHz, 12 Port.	UL-FR1	Frankenstein	231875	9/30/2024	9/18/2023
EMI TEST RECEIVER	Rohde & Schwarz	ESW44	170063	2/29/2024	2/27/2023
Antenna, Horn 1-18GHz	ETS-Lindgren (Cedar Park, Texas)	3117	226672	1/9/2024	1/9/2023
RF Filter Box, 1-18GHz, 17 Ports	UL-FR1	RATS 2	225079	4/30/2024	4/21/2023
EMI TEST RECEIVER	Rohde & Schwarz	ESW44	235670	4/30/2024	4/6/2023
Antenna, Horn 1-18GHz	ETS-Lindgren	3117	223084	10/25/2023	10/25/2022
Antenna, Horn 1-18GHz	ETS-Lindgren	3117	200785	10/25/2023	10/25/2022
Wideband Communication Test Set, Call Box	Rohde & Schwarz (Koeln) GmbH & Co. KG	CMW500	80105	2/29/2024	2/17/2023
Wideband Communication Test Set, Call Box	Rohde & Schwarz (Koeln) GmbH & Co. KG	CMW500	80581	2/29/2024	2/16/2023
ANTENNA, DIPOLE	ETS-Lindgren (Cedar Park, Texas)	3121C DB4	80805	5/31/2024	5/4/2023
ANTENNA, DIPOLE	ETS-Lindgren	3121C DB4	89477	4/30/2024	4/10/2023
Signal Generator, 8KHz-40GHz	Rohde & Schwarz	SMA100B	195765	2/29/2024	2/21/2023
Directional Coupler	KRYTAR	152610	231742	02/29/2024	2/24/2023
Rf coaxial cable, DC to 40GHz, 2.92mm	Pasternack Enterprises	PE360-36	231381	11/01/2023	11/01/2022
Rf coaxial cable, DC to 40GHz, 2.92mm	Pasternack Enterprises	PE360-36	231379	11/01/2023	11/01/2022
AC Line Conducted					
Description	Manufacturer	Model	ID Num	Cal Due	Last Cal
EMI Test Receiver 9kHz-7GHz	Rohde & Schwarz	ESR	93091	2/29/2024	3/29/2023
LISN for Conducted Emissions CISPR-16	FISCHER CUSTOM COMMUNICATIONS	FCC-LISN-50/250-25-2-01-480V	175764	1/31/2024	1/31/2023
Transient Limiter	TE	TBFL1	207996	8/31/2024	8/10/2023
UL AUTOMATION SOFTWARE					
Radiated Software	UL	UL EMC		Ver 9.5, May 1, 2023	
Conducted Software	UL	Antenna Port		Ver 2020.8.16	
Conducted Software	UL	PV		Ver 2023.08.14	
Conducted Software	UL	CLT		Ver 2023.06.21	
AC Line Conducted Software	UL	UL EMC		Ver 9.5, Mar 3, 2023	

NOTES:

*Equipment listed above that has a calibration due date during the testing period, the testing is completed before equipment expiration date.

8. RF OUTPUT POWER VERIFICATION

EUT includes different power levels for head use configuration and body use configuration and the below tables contain the highest of all configurations average conducted output powers as follows:

8.1. GSM

Using CMW500 Communication Test Set

Function: Menu select > GSM Mobile Station > GSM 850/900/1800/1900

Press **Connection control** to choose the different menus

Press **RESET** > choose all to reset all settings

Connection	Press Signal Off to turn off the signal and change settings Network Support > GSM+GPRS or GSM+EGPRS Main Service > Packet Data Service selection > Test Mode A – Auto Slot Config. off
MS Signal	Press Slot Config bottom on the right twice to select and change the number of time slots and power setting > Slot configuration > Uplink/Gamma > 33 dBm for GPRS 850/900 > 27 dBm for EGPRS 850/900 > 30 dBm for GPRS1800/1900 > 26 dBm for EGPRS1800/1900
BS Signal	Enter the same channel number for TCH channel (test channel) and BCCH channel Frequency Offset > + 0 Hz Mode > BCCH and TCH BCCH Level > -85 dBm (May need to adjust if link is not stable) BCCH Channel > choose desire test channel [Enter the same channel number for TCH channel (test channel) and BCCH channel] Channel Type > Off P0> 4 dB Slot Config > Unchanged (if already set under MS Signal) TCH > choose desired test channel Hopping > Off Main Timeslot > 3 (Default)
Network	Coding Scheme > CS 4 (GPRS) and MCS5 (EGPRS) Bit Stream > 2E9-1PSR Bit Pattern
AF/RF	Enter appropriate offsets for Ext. Att. Output and Ext. Att. Input
Connection	Press Signal On to turn on the signal and change settings

RESULT

8.1.1. GSM 850

Test Engineer ID:	27342	Test Date:	10/3/2023
--------------------------	-------	-------------------	-----------

Mode	Coding Scheme	Time Slots	Ch No.	Freq. (MHz)	Conducted Average Power (dBm)
GPRS (GMSK)	CS1	1	128	824.2	33.10
			190	836.6	33.24
			251	848.8	32.78
		2	128	824.2	30.89
			190	836.6	30.68
			251	848.8	30.57
		3	128	824.2	29.22
			190	836.6	29.28
			251	848.8	28.93
		4	128	824.2	28.03
			190	836.6	28.08
			251	848.8	27.96
EGPRS (8PSK)	MCS5	1	128	824.2	26.81
			190	836.6	26.83
			251	848.8	26.60
		2	128	824.2	25.20
			190	836.6	25.26
			251	848.8	25.03
		3	128	824.2	23.84
			190	836.6	23.85
			251	848.8	23.66
		4	128	824.2	22.53
			190	836.6	22.55
			251	848.8	22.37

8.1.2. GSM 1900

Test Engineer ID:	27342	Test Date:	10/3/2023
--------------------------	-------	-------------------	-----------

Mode	Coding Scheme	Time Slots	Ch No.	Freq. (MHz)	Conducted Average Power (dBm)
GPRS (GMSK)	CS1	1	512	1850.2	29.2
			661	1880	29.3
			810	1909.8	29.2
		2	512	1850.2	26.9
			661	1880	26.8
			810	1909.8	26.7
		3	512	1850.2	25.0
			661	1880	25.3
			810	1909.8	25.2
		4	512	1850.2	23.7
			661	1880	23.8
			810	1909.8	23.6
EGPRS (8PSK)	MCS5	1	512	1850.2	25.3
			661	1880	25.3
			810	1909.8	25.4
		2	512	1850.2	23.4
			661	1880	23.7
			810	1909.8	23.5
		3	512	1850.2	22.0
			661	1880	22.4
			810	1909.8	22.1
		4	512	1850.2	21.1
			661	1880	21.2
			810	1909.8	20.9

8.2. WCDMA

TEST PROCEDURE

The transmitter output was connected to the input terminal of Directional Coupler via calibrated coaxial cable. The output coupling terminal of the Directional Coupler was directly connected to a spectrum analyzer while the output through terminal connected to the communication test set via calibrated coaxial cable.

The output power was measured with the spectrum analyzer at the low, middle and high channel in each band.

- Set the spectrum analyzer span wide enough or greater than the modulated signal BW.
- Set a spectrum analyzer at peak detection mode with VBW \geq RBW \geq 26dB BW, typically 5MHz.
- Set a marker to point the corresponding peak value.

REL 99

The following tests were completed according to the test requirements outlined in section 5.2 of the 3GPP TS34.121-1 specification. The DUT supports power Class 3, which has a nominal maximum output power of 24 dBm (+1.7/-3.7).

Mode	Subtest	Rel99
WCDMA General Settings	Loopback Mode	Test Mode 2
	Rel99 RMC	12.2kbps RMC
	Power Control Algorithm	Algorithm2
	β_c/β_d	8/15

HSDPA REL 5

The following 4 Sub-tests were completed according to Release 5 procedures in table C.10.1.4 of 3GPP TS 34.121-1

A summary of these settings are illustrated below:

Table C.10.1.4: β values for transmitter characteristics tests with HS-DPCCH

Sub-test	β_c	β_d	β_d (SF)	β_c/β_d	β_{HS} (Note 1, Note 2)	CM (dB) (Note 3)	MPR (dB) (Note 3)
1	2/15	15/15	64	2/15	4/15	0.0	0.0
2	12/15 (Note 4)	15/15 (Note 4)	64	12/15 (Note 4)	24/15	1.0	0.0
3	15/15	8/15	64	15/8	30/15	1.5	0.5
4	15/15	4/15	64	15/4	30/15	1.5	0.5

Note 1: Δ_{ACK} , Δ_{NACK} and $\Delta_{CQI} = 30/15$ with $\beta_{HS} = 30/15 * \beta_c$.

Note 2: For the HS-DPCCH power mask requirement test in clause 5.2C, 5.7A, and the Error Vector Magnitude (EVM) with HS-DPCCH test in clause 5.13.1A, and HSDPA EVM with phase discontinuity in clause 5.13.1AA, Δ_{ACK} and $\Delta_{NACK} = 30/15$ with $\beta_{HS} = 30/15 * \beta_c$, and $\Delta_{CQI} = 24/15$ with $\beta_{HS} = 24/15 * \beta_c$.

Note 3: CM = 1 for $\beta_c/\beta_d = 12/15$, $\beta_{HS}/\beta_c = 24/15$. For all other combinations of DPDCH, DPCCH and HS-DPCCH the MPR is based on the relative CM difference. This is applicable for only UEs that support HSDPA in release 6 and later releases.

Note 4: For subtest 2 the β_c/β_d ratio of 12/15 for the TFC during the measurement period (TF1, TF0) is achieved by setting the signalled gain factors for the reference TFC (TF1, TF1) to $\beta_c = 11/15$ and $\beta_d = 15/15$.

HSPA REL 6 (HSDPA & HSUPA)

The following 5 Sub-tests were completed according to Release 6 procedures in table C.11.1.3 of 3GPP TS 34.121-1. A summary of these settings are illustrated below:

Table C.11.1.3: β values for transmitter characteristics tests with HS-DPCCH and E-DCH

Sub-test	β_c	β_d	β_d (SF)	β_c/β_d	β_{HS} (Note 1)	β_{ec}	β_{ed} (Note 4) (Note 5)	β_{ed} (SF)	β_{ed} (Codes)	CM (dB) (Note 2)	MPR (dB) (Note 2) (Note 6)	AG Index (Note 5)	E-TFCI
1	11/15 (Note 3)	15/15 (Note 3)	64	11/15 (Note 3)	22/15	209/25	1309/225	4	1	1.0	0.0	20	75
2	6/15	15/15	64	6/15	12/15	12/15	94/75	4	1	3.0	2.0	12	67
3	15/15	9/15	64	15/9	30/15	30/15	β_{ed1} : 47/15 β_{ed2} : 47/15	4 4	2	2.0	1.0	15	92
4	2/15	15/15	64	2/15	4/15	2/15	56/75	4	1	3.0	2.0	17	71
5	15/15	0	-	-	5/15	5/15	47/15	4	1	1.0	0.0	12	67

Note 1: For sub-test 1 to 4, Δ_{ACK} , Δ_{NACK} and $\Delta_{CQI} = 30/15$ with $\beta_{HS} = 30/15 * \beta_c$. For sub-test 5, Δ_{ACK} , Δ_{NACK} and $\Delta_{CQI} = 5/15$ with $\beta_{HS} = 5/15 * \beta_c$.

Note 2: CM = 1 for $\beta_c/\beta_d = 12/15$, $\beta_{HS}/\beta_c = 24/15$. For all other combinations of DPDCH, DPCCH, HS-DPCCH, E-DPDCH and E-DPCCH the MPR is based on the relative CM difference.

Note 3: For subtest 1 the β_c/β_d ratio of 11/15 for the TFC during the measurement period (TF1, TF0) is achieved by setting the signalled gain factors for the reference TFC (TF1, TF1) to $\beta_c = 10/15$ and $\beta_d = 15/15$.

Note 4: In case of testing by UE using E-DPDCH Physical Layer category 1, Sub-test 3 is omitted according to TS25.306 Table 5.1g.

Note 5: β_{ed} can not be set directly; it is set by Absolute Grant Value.

Note 6: For subtests 2, 3 and 4, UE may perform E-DPDCH power scaling at max power which could result in slightly smaller MPR values.

DUAL CARRIER HSDPA (DC-HSDPA (REL 8, CAT 24))

The following 4 Sub-tests for DC-HSDPA were completed according to Release 8 procedures in table C08.1.12 of 3GPP TS 34.121-1. A summary of subtest settings are illustrated below:

Table C.8.1.12: Fixed Reference Channel H-Set 12

Parameter	Unit	Value
Nominal Avg. Inf. Bit Rate	kbps	60
Inter-TTI Distance	TTI's	1
Number of HARQ Processes	Processes	6
Information Bit Payload (N_{INF})	Bits	120
Number Code Blocks	Blocks	1
Binary Channel Bits Per TTI	Bits	960
Total Available SML's in UE	SML's	19200
Number of SML's per HARQ Proc.	SML's	3200
Coding Rate		0.15
Number of Physical Channel Codes	Codes	1
Modulation		QPSK
<p>Note 1: The RMC is intended to be used for DC-HSDPA mode and both cells shall transmit with identical parameters as listed in the table.</p> <p>Note 2: Maximum number of transmission is limited to 1, i.e., retransmission is not allowed. The redundancy and constellation version 0 shall be used.</p>		

RESULT

8.2.1. WCDMA BAND 5

Test Engineer ID:	27342	Test Date:	9/15/2023
-------------------	-------	------------	-----------

Band	Mode		UL Ch No.	Freq. (MHz)	MPR (dB)	Conducted Average Power (dBm)
W-CDMA Band 5 (850MHz)	Rel 99	RMC, 12.2 kbps	4132	826.4	N/A	24.0
			4183	836.6	N/A	23.8
			4233	846.6	N/A	23.8
	HSDPA	Subtest 1	4132	826.4	0	23.9
			4183	836.6	0	23.8
			4233	846.6	0	23.8
		Subtest 2	4132	826.4	0	23.9
			4183	836.6	0	23.9
			4233	846.6	0	23.9
		Subtest 3	4132	826.4	0.5	23.9
			4183	836.6	0.5	23.8
			4233	846.6	0.5	23.9
		Subtest 4	4132	826.4	0.5	23.9
			4183	836.6	0.5	23.9
			4233	846.6	0.5	23.9
	HSPA (HSDPA & HSUPA)	Subtest 1	4132	826.4	0	23.0
			4183	836.6	0	22.9
			4233	846.6	0	22.9
		Subtest 2	4132	826.4	2	22.9
			4183	836.6	2	22.8
			4233	846.6	2	22.9
		Subtest 3	4132	826.4	1	22.9
			4183	836.6	1	22.8
			4233	846.6	1	22.9
		Subtest 4	4132	826.4	2	22.9
			4183	836.6	2	22.9
			4233	846.6	2	22.9
		Subtest 5	4132	826.4	0	23.8
			4183	836.6	0	23.9
			4233	846.6	0	23.9
	DC-HSDPA	Subtest 1	4132	826.4	0	23.8
			4183	836.6	0	23.9
			4233	846.6	0	23.9
		Subtest 2	4132	826.4	0	23.5
			4183	836.6	0	23.9
			4233	846.6	0	23.8
		Subtest 3	4132	826.4	0.5	23.5
			4183	836.6	0.5	23.9
			4233	846.6	0.5	23.8
		Subtest 4	4132	826.4	0.5	23.5
			4183	836.6	0.5	23.9
			4233	846.6	0.5	23.8

8.2.2. WCDMA BAND 2

Test Engineer ID:	27342	Test Date:	10/3/2023
-------------------	-------	------------	-----------

Band	Mode		UL Ch No.	Freq. (MHz)	MPR (dB)	Conducted Average Power (dBm)	
W-CDMA Band 2 (1900MHz)	Rel 99	RMC, 12.2 kbps	9262	1852.4	N/A	22.7	
			9400	1880.0	N/A	22.9	
			9538	1907.6	N/A	22.9	
	HSDPA	Subtest 1	9262	1852.4	0	22.8	
			9400	1880.0	0	22.9	
			9538	1907.6	0	23.0	
		Subtest 2	9262	1852.4	0	22.8	
			9400	1880.0	0	22.9	
			9538	1907.6	0	23.0	
		Subtest 3	9262	1852.4	0.5	22.8	
			9400	1880.0	0.5	23.0	
			9538	1907.6	0.5	23.0	
		Subtest 4	9262	1852.4	0.5	22.8	
			9400	1880.0	0.5	23.0	
			9538	1907.6	0.5	23.0	
		HSPA (HSDPA & HSUPA)	Subtest 1	9262	1852.4	0	21.8
				9400	1880.0	0	22.0
				9538	1907.6	0	22.0
	Subtest 2		9262	1852.4	2	21.8	
			9400	1880.0	2	22.0	
			9538	1907.6	2	22.0	
	Subtest 3		9262	1852.4	1	21.8	
			9400	1880.0	1	21.9	
			9538	1907.6	1	21.9	
	Subtest 4		9262	1852.4	2	21.8	
			9400	1880.0	2	21.9	
			9538	1907.6	2	21.9	
	Subtest 5		9262	1852.4	0	22.8	
			9400	1880.0	0	23.0	
			9538	1907.6	0	23.0	
	DC-HSDPA	Subtest 1	9262	1852.4	0	22.8	
			9400	1880.0	0	23.0	
			9538	1907.6	0	22.9	
		Subtest 2	9262	1852.4	0	22.8	
			9400	1880.0	0	23.0	
			9538	1907.6	0	22.9	
		Subtest 3	9262	1852.4	0.5	22.8	
			9400	1880.0	0.5	23.0	
			9538	1907.6	0.5	22.9	
		Subtest 4	9262	1852.4	0.5	22.8	
			9400	1880.0	0.5	23.0	
			9538	1907.6	0.5	23.0	

8.2.3. WCDMA BAND 4

Test Engineer ID:	27342	Test Date:	10/3/2023
-------------------	-------	------------	-----------

Band	Mode		UL Ch No.	Freq. (MHz)	MPR (dB)	Conducted Average Power (dBm)	
W-CDMA Band 4 (1700MHz)	Rel 99	RMC, 12.2 kbps	1312	1712.4	N/A	22.7	
			1413	1732.6	N/A	22.7	
			1513	1752.6	N/A	23.0	
	HSDPA	Subtest 1	1312	1712.4	0	22.6	
			1413	1732.6	0	22.8	
			1513	1752.6	0	23.0	
		Subtest 2	1312	1712.4	0	22.7	
			1413	1732.6	0	22.8	
			1513	1752.6	0	23.0	
		Subtest 3	1312	1712.4	0.5	22.7	
			1413	1732.6	0.5	22.8	
			1513	1752.6	0.5	23.0	
		Subtest 4	1312	1712.4	0.5	22.7	
			1413	1732.6	0.5	22.8	
			1513	1752.6	0.5	23.1	
		HSPA (HSDPA & HSUPA)	Subtest 1	1312	1712.4	0	21.7
				1413	1732.6	0	21.8
				1513	1752.6	0	22.0
	Subtest 2		1312	1712.4	2	21.7	
			1413	1732.6	2	21.8	
			1513	1752.6	2	22.0	
	Subtest 3		1312	1712.4	1	21.7	
			1413	1732.6	1	21.7	
			1513	1752.6	1	22.0	
	Subtest 4		1312	1712.4	2	21.7	
			1413	1732.6	2	21.8	
			1513	1752.6	2	22.0	
	Subtest 5		1312	1712.4	0	22.8	
			1413	1732.6	0	22.8	
			1513	1752.6	0	23.0	
	DC-HSDPA	Subtest 1	1312	1712.4	0	22.7	
			1413	1732.6	0	22.8	
			1513	1752.6	0	22.9	
		Subtest 2	1312	1712.4	0	22.7	
			1413	1732.6	0	22.8	
			1513	1752.6	0	22.1	
		Subtest 3	1312	1712.4	0.5	22.7	
			1413	1732.6	0.5	22.8	
			1513	1752.6	0.5	22.5	
		Subtest 4	1312	1712.4	0.5	22.8	
			1413	1732.6	0.5	22.9	
			1513	1752.6	0.5	22.8	

8.3. LTE CONDUCTED OUTPUT POWER MEASUREMENT PROCEDURE

All LTE bands conducted average power is obtained from the CMW500 telecommunication test set.

The following tests were conducted according to the test requirements outlined in section 6.2 of the 3GPP TS36.101 specification.

UE Power Class: 3 (23 +/- 2dBm). The allowed Maximum Power Reduction (MPR) for the maximum output power due to higher order modulation and transmit bandwidth configuration (resource blocks) is specified in Table 6.2.3-1 of the 3GPP TS36.101.

Table 6.2.3-1: Maximum Power Reduction (MPR) for Power Class 1, 2 and 3

Modulation	Channel bandwidth / Transmission bandwidth (N_{RB})						MPR (dB)
	1.4 MHz	3.0 MHz	5 MHz	10 MHz	15 MHz	20 MHz	
QPSK	> 5	> 4	> 8	> 12	> 16	> 18	≤ 1
16 QAM	≤ 5	≤ 4	≤ 8	≤ 12	≤ 16	≤ 18	≤ 1
16 QAM	> 5	> 4	> 8	> 12	> 16	> 18	≤ 2
64 QAM	≤ 5	≤ 4	≤ 8	≤ 12	≤ 16	≤ 18	≤ 2
64 QAM	> 5	> 4	> 8	> 12	> 16	> 18	≤ 3
256 QAM	≥ 1						≤ 5

The allowed A-MPR values specified below in Table 6.2.4.-1 of 3GPP TS36.101 are in addition to the allowed MPR requirements. All the measurements below were performed with A-MPR disabled, by using Network Signaling Value of "NS_01".

Table 6.2.4-1: Additional Maximum Power Reduction (A-MPR)

Network Signalling value	Requirements (subclause)	E-UTRA Band	Channel bandwidth (MHz)	Resources Blocks (N_{RB})	A-MPR (dB)
NS_01	6.6.2.1.1	Table 5.5-1	1.4, 3, 5, 10, 15, 20	Table 5.6-1	N/A

RESULTS

EUT includes different power levels for head use configuration and body use configuration and the below tables contain the highest of all configurations average conducted output powers as follows:

8.3.1. LTE BAND 2

Test Engineer ID:	43576	Test Date:	9/14/2023
--------------------------	-------	-------------------	-----------

OUTPUT POWER FOR LTE BAND 2 (1.4 MHz)

Bandwidth (MHz)	Modulation	RB Allocation	RB Offset	Power		
				Conducted Average (dBm)		
				18607 1850.7 MHz	18900 1880.0 MHz	19193 1909.3 MHz
1.4	QPSK	1	0	23.8	23.9	23.8
		1	3	23.7	23.6	23.7
		1	5	23.8	23.9	23.8
		3	0	23.8	24.0	23.8
		3	1	23.7	23.9	23.8
		3	3	23.8	23.8	23.7
		6	0	22.7	22.9	22.8
	16QAM	1	0	22.5	22.8	22.5
		1	3	22.6	22.9	22.8
		1	5	22.5	22.9	22.6
		3	0	22.8	22.9	22.8
		3	1	22.8	22.9	22.7
		3	3	22.8	22.8	22.7
		6	0	21.7	21.9	21.7

OUTPUT POWER FOR LTE BAND 2 (3.0 MHz)

Bandwidth (MHz)	Modulation	RB Allocation	RB Offset	Power		
				Conducted Average (dBm)		
				18615 1851.5 MHz	18900 1880.0 MHz	19185 1908.5 MHz
3.0	QPSK	1	0	23.6	23.7	23.5
		1	8	23.4	23.8	23.6
		1	14	23.7	23.7	23.7
		8	0	22.8	23.0	22.9
		8	4	22.8	22.9	22.9
		8	7	22.8	22.9	23.0
		15	0	22.7	22.9	22.8
	16QAM	1	0	22.4	23.1	22.6
		1	8	22.3	23.0	22.5
		1	14	22.3	23.1	22.5
		8	0	21.8	22.0	21.8
		8	4	21.8	21.9	21.8
		8	7	21.8	21.9	21.8
		15	0	21.7	21.9	21.8

OUTPUT POWER FOR LTE BAND 2 (5.0 MHz)

Bandwidth (MHz)	Modulation	RB Allocation	RB Offset	Power		
				Conducted Average (dBm)		
				18625	18900	19175
				1852.5 MHz	1880.0 MHz	1907.5 MHz
5.0	QPSK	1	0	23.3	23.7	23.5
		1	12	23.4	23.7	23.5
		1	24	23.4	23.7	23.6
		12	0	22.5	22.7	22.7
		12	7	22.5	22.7	22.7
		12	13	22.5	22.7	22.7
		25	0	22.5	22.8	22.7
	16QAM	1	0	22.3	22.6	22.6
		1	12	22.4	22.6	22.5
		1	24	22.4	22.6	22.5
		12	0	21.4	21.7	21.7
		12	7	21.4	21.7	21.7
		12	13	21.4	21.7	21.7
		25	0	21.5	21.7	21.6

OUTPUT POWER FOR LTE BAND 2 (10.0 MHz)

Bandwidth (MHz)	Modulation	RB Allocation	RB Offset	Power		
				Conducted Average (dBm)		
				18650	18900	19150
				1855.0 MHz	1880.0 MHz	1905.0 MHz
10.0	QPSK	1	0	23.2	23.6	23.3
		1	25	23.3	23.7	23.2
		1	49	23.4	23.6	23.5
		25	0	22.5	22.8	22.7
		25	12	22.5	22.8	22.7
		25	25	22.5	22.7	22.7
		50	0	22.5	22.8	22.7
	16QAM	1	0	22.2	22.8	22.4
		1	25	22.3	22.7	22.3
		1	49	22.2	22.8	22.4
		25	0	21.5	21.7	21.7
		25	12	21.5	21.7	21.7
		25	25	21.5	21.7	21.7
		50	0	21.5	21.7	21.7

OUTPUT POWER FOR LTE BAND 2 (15.0 MHz)

Bandwidth (MHz)	Modulation	RB Allocation	RB Offset	Power		
				Conducted Average (dBm)		
				18675	18900	19125
				1857.5 MHz	1880.0 MHz	1902.5 MHz
15.0	QPSK	1	0	23.2	23.6	23.3
		1	37	23.1	23.7	23.4
		1	74	23.2	23.7	23.4
		36	0	22.6	22.8	22.8
		36	20	22.6	22.8	22.8
		36	39	22.6	22.8	22.8
		75	0	22.6	22.8	22.8
	16QAM	1	0	22.3	22.6	22.3
		1	37	22.4	22.6	22.4
		1	74	22.3	22.7	22.4
		36	0	21.5	21.8	21.8
		36	20	21.6	21.8	21.8
		36	39	21.6	21.8	21.8
		75	0	21.5	21.8	21.8

OUTPUT POWER FOR LTE BAND 2 (20.0 MHz)

Bandwidth (MHz)	Modulation	RB Allocation	RB Offset	Power		
				Conducted Average (dBm)		
				18700	18900	19100
				1860.0 MHz	1880.0 MHz	1900.0 MHz
20.0	QPSK	1	0	22.9	23.0	22.8
		1	49	22.9	23.0	23.1
		1	99	23.0	23.0	22.7
		50	0	22.1	22.4	22.3
		50	24	22.1	22.4	22.3
		50	50	22.1	22.4	22.3
		100	0	22.1	22.4	22.3
	16QAM	1	0	22.1	22.7	22.3
		1	49	22.3	23.0	22.4
		1	99	22.2	22.8	22.5
		50	0	21.5	21.7	21.6
		50	24	21.6	21.7	21.7
		50	50	21.6	21.7	21.7
		100	0	21.6	21.7	21.7

8.3.2. LTE BAND 12

Test Engineer ID:	32061	Test Date:	9/15/2023
--------------------------	-------	-------------------	-----------

OUTPUT POWER FOR LTE BAND 12 (1.4 MHz)

Bandwidth (MHz)	Modulation	RB Allocation	RB Offset	Power		
				Conducted Average (dBm)		
				23017 699.7 MHz	23095 707.5 MHz	23173 715.3 MHz
1.4	QPSK	1	0	23.1	23.2	23.3
		1	2	22.9	23.1	23.0
		1	5	23.0	23.2	23.2
		3	0	23.1	23.2	23.3
		3	1	23.1	23.2	23.3
		3	2	23.0	23.3	23.1
		6	0	22.0	22.2	22.3
	16QAM	1	0	21.9	22.2	22.2
		1	2	21.9	22.2	22.1
		1	5	22.0	22.3	22.3
		3	0	22.1	22.4	22.3
		3	1	22.0	22.3	22.4
		3	2	22.0	22.3	22.3
		6	0	21.0	21.2	21.2

OUTPUT POWER FOR LTE BAND 12 (3.0 MHz)

Bandwidth (MHz)	Modulation	RB Allocation	RB Offset	Power		
				Conducted Average (dBm)		
				23025 700.5 MHz	23095 707.5 MHz	23165 714.5 MHz
3.0	QPSK	1	0	23.1	23.1	22.9
		1	7	22.9	22.8	22.7
		1	14	23.0	22.9	22.9
		8	0	22.2	22.2	22.2
		8	4	22.1	22.2	22.2
		8	7	22.1	22.2	22.2
		15	0	22.2	22.2	22.2
	16QAM	1	0	22.6	22.4	21.9
		1	7	22.0	22.2	21.7
		1	14	22.2	22.4	21.9
		8	0	21.2	21.3	21.3
		8	4	21.1	21.2	21.2
		8	7	21.2	21.2	21.2
		15	0	21.2	21.2	21.1

OUTPUT POWER FOR LTE BAND 12 (5.0 MHz)

Bandwidth (MHz)	Modulation	RB Allocation	RB Offset	Power		
				Conducted Average (dBm)		
				23035	23095	23155
				701.5 MHz	707.5 MHz	713.5 MHz
5.0	QPSK	1	0	23.1	23.1	23.0
		1	12	23.0	22.9	23.0
		1	24	23.1	23.1	23.0
		12	0	22.2	22.1	22.2
		12	6	22.1	22.1	22.2
		12	11	22.1	22.1	22.1
		25	0	22.2	22.1	22.1
	16QAM	1	0	22.1	22.1	22.1
		1	12	21.9	22.0	22.0
		1	24	22.1	22.1	22.1
		12	0	21.1	21.1	21.1
		12	6	21.2	21.1	21.1
		12	11	21.1	21.1	21.1
		25	0	21.1	21.1	21.2

OUTPUT POWER FOR LTE BAND 12 (10.0 MHz)

Bandwidth (MHz)	Modulation	RB Allocation	RB Offset	Power		
				Conducted Average (dBm)		
				23060	23095	23130
				704.0 MHz	707.5 MHz	711.0 MHz
10.0	QPSK	1	0	22.9	22.8	22.9
		1	24	22.8	22.7	22.8
		1	49	22.9	22.8	22.9
		25	0	22.1	22.1	22.2
		25	12	22.1	22.1	22.2
		25	24	22.1	22.1	22.2
		50	0	22.1	22.1	22.2
	16QAM	1	0	21.7	22.0	22.1
		1	24	21.7	22.0	22.1
		1	49	21.6	21.9	22.0
		25	0	21.1	21.1	21.2
		25	12	21.1	21.1	21.2
		25	24	21.0	21.0	21.2
		50	0	21.1	21.1	21.2

8.3.3. LTE BAND 13

Test Engineer ID:	32061	Test Date:	9/15/2023
--------------------------	-------	-------------------	-----------

OUTPUT POWER FOR LTE BAND 13 (5.0 MHz)

Bandwidth (MHz)	Modulation	RB Allocation	RB Offset	Power		
				Conducted Average (dBm)		
				23205 779.5 MHz	23230 782.0 MHz	23255 784.5 MHz
5.0	QPSK	1	0	23.3	23.1	23.0
		1	12	23.2	23.0	23.0
		1	24	23.3	23.1	23.1
		12	0	22.3	22.2	22.1
		12	6	22.3	22.2	22.1
		12	11	22.3	22.2	22.1
		25	0	22.3	22.2	22.2
	16QAM	1	0	22.2	22.0	21.9
		1	12	22.0	21.9	21.8
		1	24	22.2	22.1	21.9
		12	0	21.3	21.3	21.2
		12	6	21.3	21.2	21.2
		12	11	21.3	21.3	21.2
		25	0	21.3	21.2	21.2

OUTPUT POWER FOR LTE BAND 13 (10.0 MHz)

Bandwidth (MHz)	Modulation	RB Allocation	RB Offset	Power		
				Conducted Average (dBm)		
				N/A	23230 782.0 MHz	N/A
10.0	QPSK	1	0		22.9	
		1	24		22.9	
		1	49		23.0	
		25	0		22.2	
		25	12		22.3	
		25	24		22.2	
		50	0		22.3	
	16QAM	1	0		22.2	
		1	24		22.3	
		1	49		22.1	
		25	0		21.3	
		25	12		21.3	
		25	24		21.3	
		50	0		21.3	

8.3.4. LTE BAND 26 (FCC Part 90S)

Test Engineer ID:	32061	Test Date:	9/15/2023
-------------------	-------	------------	-----------

OUTPUT POWER FOR LTE BAND 26 (1.4 MHz)

Bandwidth (MHz)	Modulation	RB Allocation	RB Offset	Power		
				Conducted Average (dBm)		
				26697 814.7 MHz	26740 819 MHz	26783 823.3 MHz
1.4	QPSK	1	0	24.0	24.0	24.0
		1	2	23.8	23.7	23.8
		1	5	23.9	23.9	24.0
		3	0	24.0	24.0	24.0
		3	1	24.0	24.1	24.0
		3	2	23.9	23.9	24.0
		6	0	22.9	23.0	22.9
	16QAM	1	0	22.8	23.3	23.0
		1	2	22.9	23.5	23.2
		1	5	22.9	23.4	23.1
		3	0	23.0	23.0	23.1
		3	1	22.9	23.1	23.0
		3	2	23.0	23.1	23.0
		6	0	22.1	22.0	22.1

OUTPUT POWER FOR LTE BAND 26 (3.0 MHz)

Bandwidth (MHz)	Modulation	RB Allocation	RB Offset	Power		
				Conducted Average (dBm)		
				26705 815.5 MHz	26740 819 MHz	26775 822.5 MHz
3.0	QPSK	1	0	23.7	23.8	23.7
		1	7	23.5	23.6	23.6
		1	14	23.8	23.7	23.8
		8	0	23.0	22.9	23.0
		8	4	22.9	23.0	23.0
		8	7	23.0	22.9	23.0
		15	0	22.9	23.0	22.9
	16QAM	1	0	22.7	23.3	23.4
		1	7	22.6	23.2	23.3
		1	14	22.6	23.3	23.3
		8	0	21.9	22.1	22.0
		8	4	22.0	22.1	22.0
		8	7	21.8	22.1	21.9
		15	0	21.9	22.0	22.0

OUTPUT POWER FOR LTE BAND 26 (5.0 MHz)

Bandwidth (MHz)	Modulation	RB Allocation	RB Offset	Power		
				Conducted Average (dBm)		
				26715	26740	26765
				816.5 MHz	819 MHz	821.5 MHz
5.0	QPSK	1	0	23.7	23.6	23.6
		1	12	23.5	23.5	23.5
		1	24	23.7	23.7	23.6
		12	0	22.9	22.8	22.7
		12	6	22.9	22.8	22.7
		12	11	22.9	22.8	22.7
		25	0	23.0	22.8	22.7
	16QAM	1	0	23.2	23.2	23.1
		1	12	23.0	22.9	23.0
		1	24	23.1	23.2	23.1
		12	0	22.1	22.0	21.7
		12	6	22.1	22.0	21.6
		12	11	22.1	22.0	21.6
		25	0	22.1	21.9	21.7

OUTPUT POWER FOR LTE BAND 26 (10.0 MHz)

Bandwidth (MHz)	Modulation	RB Allocation	RB Offset	Power		
				Conducted Average (dBm)		
				N/A	26740	N/A
				N/A	819 MHz	N/A
10.0	QPSK	1	0		23.5	
		1	24		23.4	
		1	49		23.6	
		25	0		23.0	
		25	12		22.9	
		25	24		23.0	
		50	0		23.0	
	16QAM	1	0		23.4	
		1	24		23.4	
		1	49		23.3	
		25	0		22.0	
		25	12		22.0	
		25	24		22.0	
		50	0		21.9	

OUTPUT POWER FOR LTE BAND 26 (15.0 MHz)

Bandwidth (MHz)	Modulation	RB Allocation	RB Offset	Power		
				Conducted Average (dBm)		
				N/A	26765	N/A
				N/A	821.5 MHz	N/A
15.0	QPSK	1	0		23.6	
		1	24		23.5	
		1	49		23.6	
		25	0		23.0	
		25	12		22.9	
		25	24		22.9	
		50	0		22.9	
	16QAM	1	0		22.8	
		1	24		22.7	
		1	49		22.7	
		25	0		22.0	
		25	12		22.0	
		25	24		22.0	
		50	0		21.9	

8.3.5. LTE BAND 26 (FCC Part 22)

Test Engineer ID:	32061	Test Date:	9/15/2023
-------------------	-------	------------	-----------

OUTPUT POWER FOR LTE BAND 26 (1.4 MHz)

Bandwidth (MHz)	Modulation	RB Allocation	RB Offset	Power		
				Conducted Average (dBm)		
				26797 824.7 MHz	26915 836.5 MHz	27033 848.3 MHz
1.4	QPSK	1	0	23.9	24.0	23.6
		1	2	23.7	23.8	23.6
		1	5	23.9	23.9	23.7
		3	0	23.9	23.9	23.9
		3	1	24.0	23.9	23.9
		3	2	24.0	23.8	23.8
		6	0	22.9	22.8	22.9
	16QAM	1	0	22.5	22.1	22.3
		1	2	22.8	22.2	22.5
		1	5	22.6	22.2	22.3
		3	0	22.7	22.3	22.0
		3	1	22.4	22.2	22.1
		3	2	22.4	22.3	22.0
		6	0	21.4	21.3	21.0

OUTPUT POWER FOR LTE BAND 26 (3.0 MHz)

Bandwidth (MHz)	Modulation	RB Allocation	RB Offset	Power		
				Conducted Average (dBm)		
				26805 825.5 MHz	26915 836.5 MHz	27025 847.5 MHz
3.0	QPSK	1	0	23.9	23.6	23.7
		1	7	23.7	23.4	23.4
		1	14	23.9	23.7	23.7
		8	0	23.0	22.9	23.8
		8	4	22.9	22.9	22.7
		8	7	23.0	22.8	22.8
		15	0	22.9	22.9	22.8
	16QAM	1	0	22.1	22.7	22.6
		1	7	21.9	22.5	22.5
		1	14	21.9	22.7	22.6
		8	0	21.1	21.4	21.3
		8	4	21.2	21.4	21.3
		8	7	21.1	21.4	21.3
		15	0	21.2	21.3	21.4

OUTPUT POWER FOR LTE BAND 26 (5.0 MHz)

Bandwidth (MHz)	Modulation	RB Allocation	RB Offset	Power		
				Conducted Average (dBm)		
				26815	26915	27015
				826.5 MHz	836.5 MHz	846.5 MHz
5.0	QPSK	1	0	23.8	23.7	23.8
		1	12	23.8	23.7	23.6
		1	24	24.0	23.6	23.8
		12	0	22.9	22.9	22.8
		12	6	22.9	22.8	22.8
		12	11	22.9	22.8	22.8
		25	0	23.0	22.9	22.8
	16QAM	1	0	22.6	22.6	22.3
		1	12	22.4	22.4	22.2
		1	24	22.5	22.6	22.4
		12	0	21.5	21.5	21.2
		12	6	21.4	21.5	21.2
		12	11	21.4	21.5	21.2
		25	0	21.5	21.5	21.2

OUTPUT POWER FOR LTE BAND 26 (10.0 MHz)

Bandwidth (MHz)	Modulation	RB Allocation	RB Offset	Power		
				Conducted Average (dBm)		
				26840	26915	26990
				829.0 MHz	836.5 MHz	844.0 MHz
10.0	QPSK	1	0	23.9	23.5	23.6
		1	24	23.8	23.5	23.6
		1	49	23.8	23.7	23.6
		25	0	23.0	22.9	22.8
		25	12	22.9	22.9	22.8
		25	24	22.9	22.9	22.7
		50	0	22.9	22.9	22.8
	16QAM	1	0	22.4	22.6	22.7
		1	24	22.4	22.7	22.8
		1	49	22.3	22.7	22.7
		25	0	21.4	21.5	21.4
		25	12	21.4	21.4	21.3
		25	24	21.4	21.4	21.3
		50	0	21.4	21.3	21.3

OUTPUT POWER FOR LTE BAND 26 (15.0 MHz)

Bandwidth (MHz)	Modulation	RB Allocation	RB Offset	Power		
				Conducted Average (dBm)		
				26865	26915	26965
				831.5 MHz	836.5 MHz	841.5 MHz
15.0	QPSK	1	0	23.3	23.6	23.7
		1	37	23.4	23.5	23.7
		1	74	23.2	23.5	23.6
		36	0	22.9	22.9	22.8
		36	16	22.9	22.9	22.9
		36	35	23.0	22.8	22.9
		75	0	22.9	22.8	22.8
	16QAM	1	0	22.5	22.5	22.7
		1	37	22.4	22.5	22.7
		1	74	22.5	22.5	22.6
		36	0	21.5	21.5	21.4
		36	16	21.5	21.5	21.4
		36	35	21.5	21.5	21.4
		75	0	21.4	21.4	21.4

8.3.6. LTE BAND 41

Test Engineer ID:	32061	Test Date:	9/18/2023
-------------------	-------	------------	-----------

OUTPUT POWER FOR LTE BAND 41 (5.0 MHz)

Bandwidth (MHz)	Modulation	RB Allocation	RB Offset	Power		
				Conducted Average (dBm)		
				39675 2498.5 MHz	40620 2593.0 MHz	41565 2687.5 MHz
5.0	QPSK	1	0	22.17	23.26	23.21
		1	12	22.22	23.14	23.27
		1	24	22.12	21.98	23.16
		12	0	21.31	21.96	22.19
		12	6	21.33	21.97	22.21
		12	11	21.30	21.95	22.22
		25	0	21.37	21.82	22.25
	16QAM	1	0	21.59	21.48	21.89
		1	12	21.23	21.67	21.75
		1	24	21.58	21.09	21.98
		12	0	20.35	21.10	21.24
		12	6	20.32	21.09	21.21
		12	11	20.34	20.98	21.28
		25	0	20.41	21.38	21.28

OUTPUT POWER FOR LTE BAND 41 (10.0 MHz)

Bandwidth (MHz)	Modulation	RB Allocation	RB Offset	Power		
				Conducted Average (dBm)		
				39700 2501.0 MHz	40620 2593.0 MHz	41540 2685.0 MHz
10.0	QPSK	1	0	22.2	22.9	22.6
		1	24	22.0	22.7	22.6
		1	49	22.1	22.8	22.7
		25	0	21.4	22.1	21.9
		25	12	21.3	22.1	21.9
		25	24	21.3	22.1	21.9
		50	0	21.4	22.1	21.9
	16QAM	1	0	21.4	22.1	22.2
		1	24	21.4	22.2	22.2
		1	49	21.4	21.9	22.2
		25	0	20.4	21.2	20.9
		25	12	20.4	21.2	20.9
		25	24	20.4	21.1	20.9
		50	0	20.4	21.2	20.9

OUTPUT POWER FOR LTE BAND 41 (15.0 MHz)

Bandwidth (MHz)	Modulation	RB Allocation	RB Offset	Power		
				Conducted Average (dBm)		
				39725	40620	41515
				2503.5 MHz	2593.0 MHz	2682.5 MHz
15.0	QPSK	1	0	22.5	23.0	22.7
		1	37	22.6	22.9	22.6
		1	74	22.4	22.8	22.7
		36	0	21.4	22.1	21.9
		36	16	21.4	22.0	21.9
		36	35	21.4	22.0	21.9
		75	0	21.4	22.0	21.9
	16QAM	1	0	21.8	22.3	22.4
		1	37	21.5	22.0	22.2
		1	74	21.7	22.2	22.4
		36	0	20.4	21.1	20.9
		36	16	20.4	21.1	20.9
		36	35	20.4	21.0	20.9
		75	0	20.4	21.0	20.8

OUTPUT POWER FOR LTE BAND 41 (20.0 MHz)

Bandwidth (MHz)	Modulation	RB Allocation	RB Offset	Power		
				Conducted Average (dBm)		
				39750	40620	41490
				2506.0 MHz	2593.0 MHz	2680.0 MHz
20.0	QPSK	1	0	22.5	23.1	23.3
		1	49	22.5	23.1	23.1
		1	99	22.5	22.9	23.2
		50	0	21.2	22.0	22.3
		50	24	21.3	22.0	22.2
		50	49	21.3	21.9	22.2
		100	0	21.2	21.9	22.3
	16QAM	1	0	21.4	22.0	22.0
		1	49	21.6	22.1	22.0
		1	99	21.4	21.8	21.9
		50	0	20.4	21.0	21.3
		50	24	20.4	21.0	21.2
		50	49	20.4	20.9	21.2
		100	0	20.3	20.9	21.2

8.3.7. LTE BAND 66

Test Engineer ID:	32061	Test Date:	9/18/2023
--------------------------	-------	-------------------	-----------

OUTPUT POWER FOR LTE BAND 66 (1.4 MHz)

Bandwidth (MHz)	Modulation	RB Allocation	RB Offset	Power		
				Conducted Average (dBm)		
				131979 1710.7 MHz	132322 1745.0 MHz	132665 1779.3 MHz
1.4	QPSK	1	0	21.4	21.6	21.5
		1	2	21.5	21.5	21.3
		1	5	21.5	21.6	21.5
		3	0	21.5	21.6	21.4
		3	1	21.4	21.6	21.4
		3	2	21.5	21.5	21.4
		6	0	21.5	21.6	21.5
	16QAM	1	0	21.6	21.6	21.5
		1	2	21.5	21.8	21.4
		1	5	21.6	21.8	21.5
		3	0	21.6	21.6	21.4
		3	1	21.6	21.6	21.5
		3	2	21.5	21.6	21.4
		6	0	21.1	21.1	21.0

OUTPUT POWER FOR LTE BAND 66 (3.0 MHz)

Bandwidth (MHz)	Modulation	RB Allocation	RB Offset	Power		
				Conducted Average (dBm)		
				131987 1711.5 MHz	132322 1745.0 MHz	132657 1778.5 MHz
3.0	QPSK	1	0	21.2	22.1	21.5
		1	7	21.1	21.8	21.2
		1	14	21.2	22.1	21.4
		8	0	21.1	22.1	21.4
		8	4	21.1	22.1	21.4
		8	7	21.2	22.1	21.5
		15	0	21.2	22.1	21.5
	16QAM	1	0	21.3	22.4	21.8
		1	7	21.2	22.0	21.3
		1	14	21.1	22.2	21.8
		8	0	20.7	21.6	21.0
		8	4	20.7	21.6	21.0
		8	7	20.7	21.6	20.9
		15	0	20.7	21.6	21.0

OUTPUT POWER FOR LTE BAND 66 (5.0 MHz)

Bandwidth (MHz)	Modulation	RB Allocation	RB Offset	Power		
				Conducted Average (dBm)		
				131997	132322	132647
				1712.5 MHz	1745.0 MHz	1777.5 MHz
5.0	QPSK	1	0	21.1	21.5	21.4
		1	12	21.1	21.6	21.4
		1	24	21.2	21.6	21.5
		12	0	21.2	21.6	21.5
		12	6	21.2	21.6	21.5
		12	11	21.2	21.6	21.5
		25	0	21.2	21.6	21.5
	16QAM	1	0	21.2	21.8	21.5
		1	12	21.2	21.8	21.4
		1	24	21.3	21.9	21.5
		12	0	20.7	21.2	21.0
		12	6	20.6	21.2	20.9
		12	11	20.6	21.2	21.0
		25	0	20.7	21.2	21.0

OUTPUT POWER FOR LTE BAND 66 (10.0 MHz)

Bandwidth (MHz)	Modulation	RB Allocation	RB Offset	Power		
				Conducted Average (dBm)		
				132022	132322	132622
				1715.0 MHz	1745.0 MHz	1775.0 MHz
10.0	QPSK	1	0	21.6	21.5	21.4
		1	24	21.6	21.5	21.4
		1	49	21.7	21.5	21.4
		25	0	21.7	21.5	21.4
		25	12	21.6	21.5	21.4
		25	24	21.7	21.5	21.4
		50	0	21.6	21.5	21.4
	16QAM	1	0	21.8	21.6	21.5
		1	24	21.9	21.7	21.5
		1	49	21.9	21.7	21.5
		25	0	21.2	21.1	20.9
		25	12	21.2	21.2	20.9
		25	24	21.2	21.2	20.9
		50	0	21.2	21.2	20.9

OUTPUT POWER FOR LTE BAND 66 (15.0 MHz)

Bandwidth (MHz)	Modulation	RB Allocation	RB Offset	Power		
				Conducted Average (dBm)		
				132047	132322	132597
				1717.5 MHz	1745.0 MHz	1772.5 MHz
15.0	QPSK	1	0	21.3	21.5	21.3
		1	37	21.2	21.4	21.2
		1	74	21.3	21.6	21.4
		36	0	21.3	21.6	21.4
		36	16	21.3	21.6	21.4
		36	35	21.3	21.6	21.4
		75	0	21.3	21.6	21.4
	16QAM	1	0	21.2	21.6	21.3
		1	37	21.2	21.5	21.3
		1	74	21.2	21.6	21.3
		36	0	20.8	21.0	20.8
		36	16	20.8	21.1	20.8
		36	35	20.8	21.1	20.9
		75	0	20.8	21.1	20.9

OUTPUT POWER FOR LTE BAND 66 (20.0 MHz)

Bandwidth (MHz)	Modulation	RB Allocation	RB Offset	Power		
				Conducted Average (dBm)		
				132072	132322	132572
				1720.0 MHz	1745.0 MHz	1770.0 MHz
20.0	QPSK	1	0	21.5	22.0	21.9
		1	49	21.5	22.0	22.0
		1	99	21.7	22.1	21.9
		50	0	21.7	22.1	21.9
		50	24	21.7	22.1	21.9
		50	49	21.7	22.1	21.9
		100	0	21.7	22.1	21.9
	16QAM	1	0	21.8	22.3	22.2
		1	49	21.9	22.5	22.2
		1	99	21.9	22.3	22.1
		50	0	21.2	21.6	21.4
		50	24	21.2	21.6	21.4
		50	49	21.2	21.5	21.4
		100	0	21.2	21.6	21.4

9. CONDUCTED TEST RESULTS

9.1. OCCUPIED BANDWIDTH

RULE PART(S)

FCC: §2.1049

LIMITS

For reporting purposes only.

TEST PROCEDURE

The transmitter output was connected to a calibrated coaxial cable and coupler, the other end of which was connected to a spectrum analyzer. The occupied bandwidth was measured with the spectrum analyzer at the middle channel in each band. The 99% and -26dB bandwidths was also measured and recorded.

RESULTS

There is no limit required and power is the same for low, middle and high channel; therefore, only middle channel was tested. Worst-case plots (highest bandwidth) are reported only.

GSM

Band	Modulation	Channel	f(MHz)	99% BW (KHz)	-26dB BW (KHz)
850	GPRS	190	836.6	247.27	314.60
	EGPRS			248.28	311.20
1900	GPRS	661	1880.0	245.87	320.20
	EGPRS			241.83	305.20

WCDMA

Band	Modulation	Channel	f(MHz)	99% BW (MHz)	-26dB BW (MHz)
BAND 5	REL 99	4408	836.6	4.1802	4.738
	HSDPA			4.1823	4.719
BAND 2	REL 99	9800	1880.0	4.1748	4.731
	HSDPA			4.1767	4.725
BAND 4	REL 99	1638	1732.6	4.1788	4.744
	HSDPA			4.1902	4.759

LTE BAND 2

Band	Mode	RB Allocation/RB Offset	f(MHz)	99% BW (MHz)	-26dB BW (MHz)
LTE BAND 2	1.4MHz, QPSK	6/0	1880.0	1.0904	1.319
	1.4MHz, 16QAM			1.0943	1.344
	3MHz, QPSK	15/0		2.7089	3.097
	3MHz, 16QAM			2.7022	3.090
	5MHz, QPSK	25/0		4.5120	5.255
	5MHz, 16QAM			4.5126	5.280
	10MHz, QPSK	50/0		9.0118	10.200
	10MHz, 16QAM			8.9973	10.280
	15MHz, QPSK	75/0		13.447	15.040
	15MHz, 16QAM			13.444	14.980
	20MHz, QPSK	100/0		17.902	19.720
	20MHz, 16QAM			17.911	19.580

LTE BAND 12

Band	Mode	RB Allocation/RB Offset	f(MHz)	99% BW (MHz)	-26dB BW (MHz)
LTE BAND 12	1.4 MHz, QPSK	6/0	707.5	1.0904	1.297
	1.4 MHz, 16QAM			1.0940	1.328
	3 MHz, QPSK	15/0		2.7070	3.072
	3 MHz, 16QAM			2.7069	3.121
	5 MHz, QPSK	25/0		4.4976	5.160
	5 MHz, 16QAM			4.5027	5.250
	10 MHz, QPSK	50/0		8.9476	10.200
	10 MHz, 16QAM			8.9426	10.070

LTE BAND 13

Band	Mode	RB Allocation/RB Offset	f(MHz)	99% BW (MHz)	-26dB BW (MHz)
LTE BAND 13	5 MHz, QPSK	25/0	782.0	4.5175	5.390
	5 MHz, 16QAM			4.5179	5.369
	10 MHz, QPSK	50/0		9.0524	10.320
	10 MHz, 16QAM			9.0251	10.53

LTE BAND 26(FCC PART 90S)

Band	Mode	RB Allocation/RB Offset	f(MHz)	99% BW (MHz)	-26dB BW (MHz)
LTE BAND 26	1.4 MHz, QPSK	6/0	819.0	1.0951	1.317
	1.4 MHz, 16QAM			1.0885	1.311
	3 MHz, QPSK	15/0		2.7072	3.071
	3 MHz, 16QAM			2.7066	3.080
	5 MHz, QPSK	25/0		4.5179	5.264
	5 MHz, 16QAM			4.5147	5.234
	10 MHz, QPSK	50/0		9.0197	10.280
	10 MHz, 16QAM			9.0202	10.330
	15 MHz, QPSK	75/0		13.485	15.200
	15 MHz, 16QAM			13.393	13.820

LTE BAND 26 (FCC PART 22)

Band	Mode	RB Allocation/RB Offset	f(MHz)	99% BW (MHz)	-26dB BW (MHz)
LTE BAND 26	1.4 MHz, QPSK	6/0	836.5	1.0957	1.337
	1.4 MHz, 16QAM			1.0898	1.293
	3 MHz, QPSK	15/0		2.7023	3.072
	3 MHz, 16QAM			2.6983	3.012
	5 MHz, QPSK	25/0		4.5276	5.241
	5 MHz, 16QAM			4.512	5.249
	10 MHz, QPSK	50/0		9.0412	10.450
	10 MHz, 16QAM			9.0248	10.360
	15 MHz, QPSK	75/0		13.516	15.160
	15 MHz, 16QAM			13.499	15.060

LTE BAND 41

Band	Mode	RB Allocation/RB Offset	f(MHz)	99% BW (MHz)	-26dB BW (MHz)
LTE BAND 41	5MHz, QPSK	25/0	2593.0	4.5020	5.325
	5MHz, 16QAM			4.5190	5.245
	10MHz, QPSK	50/0		8.9978	10.120
	10MHz, 16QAM			8.9731	10.140
	15MHz, QPSK	75/0		13.417	15.220
	15MHz, 16QAM			13.418	14.810
	20MHz, QPSK	100/0		17.914	19.710
	20MHz, 16QAM			17.899	19.500

LTE BAND 66

Band	Mode	RB Allocation/RB Offset	f(MHz)	99% BW (MHz)	-26dB BW (MHz)
LTE BAND 66	1.4MHz, QPSK	6/0	1745.0	1.0899	1.308
	1.4MHz, 16QAM			1.0911	1.283
	3MHz, QPSK	15/0		2.7006	3.105
	3MHz, 16QAM			2.6926	3.046
	5MHz, QPSK	25/0		4.5041	5.327
	5MHz, 16QAM			4.5077	5.364
	10MHz, QPSK	50/0		8.9826	10.390
	10MHz, 16QAM			8.9773	10.130
	15MHz, QPSK	75/0		13.422	15.120
	15MHz, 16QAM			13.449	15.060
	20MHz, QPSK	100/0		17.914	19.870
	20MHz, 16QAM			17.915	19.900

9.1.1. GSM

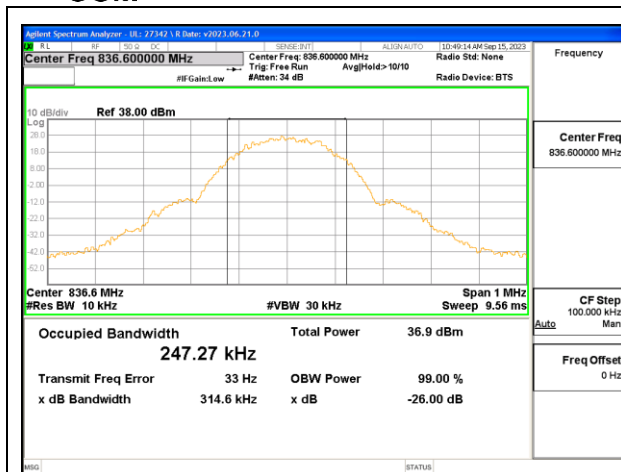

GSM 850 GPRS Middle Channel

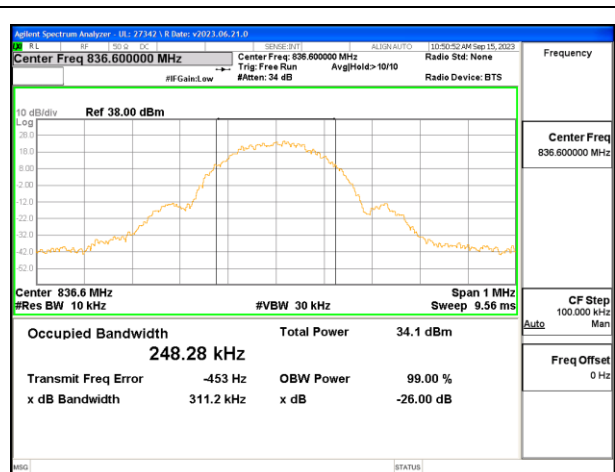

GSM 850 EGPRS Middle Channel

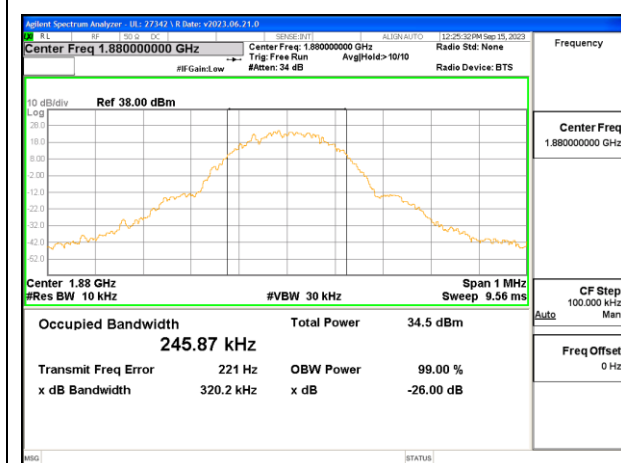

GSM 1900 GPRS Middle Channel

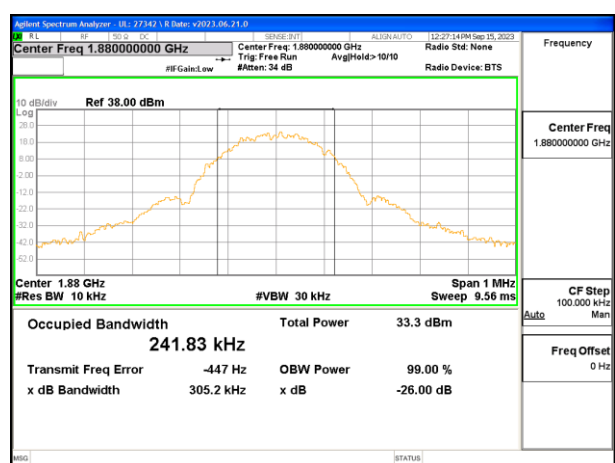

GSM 1900 EGPRS Middle Channel

9.1.2. WCDMA

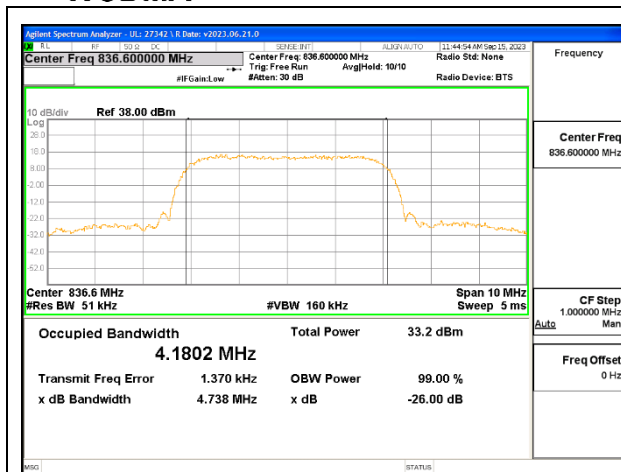

WCDMA Band 5 Rel 99 Middle Channel

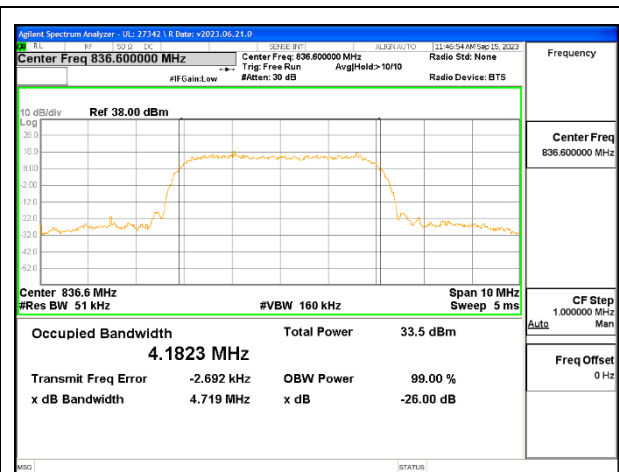

WCDMA Band 5 HSDPA Middle Channel

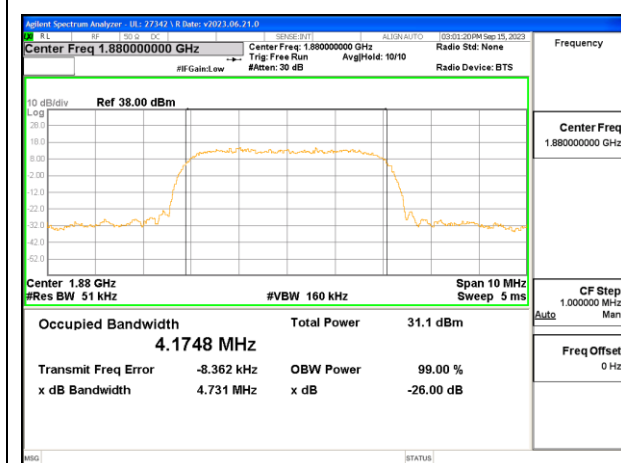

WCDMA Band 2 Rel 99 Middle Channel

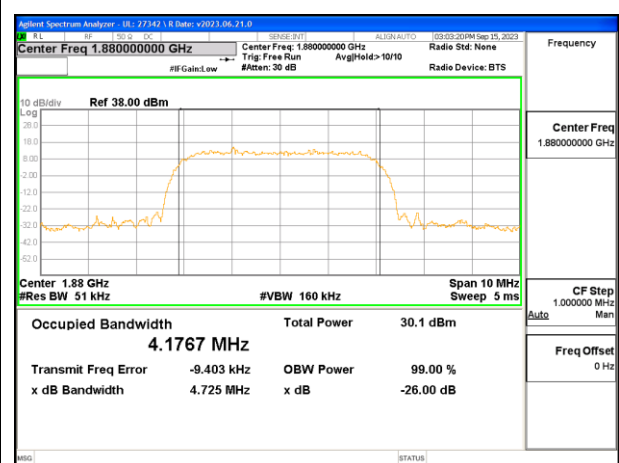

WCDMA Band 2 HSDPA Middle Channel

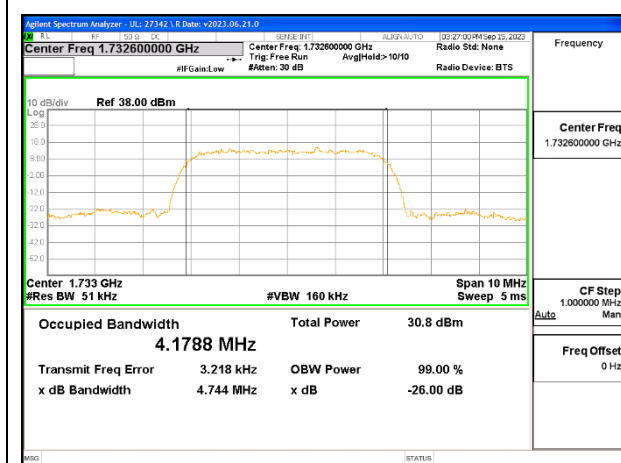

WCDMA Band 4 Rel 99 Middle Channel

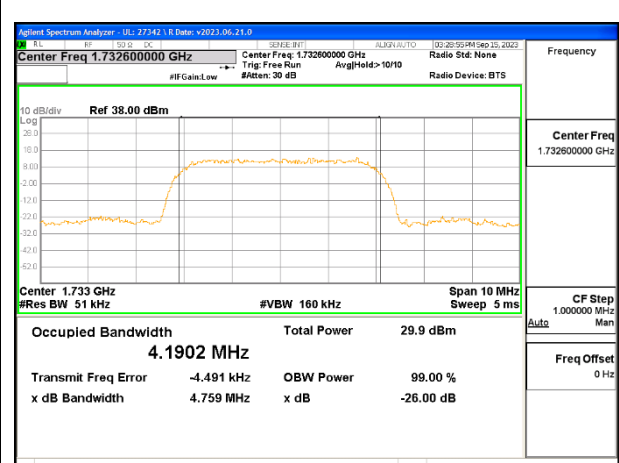

WCDMA Band 4 HSDPA Middle Channel

9.1.3. LTE BAND 2

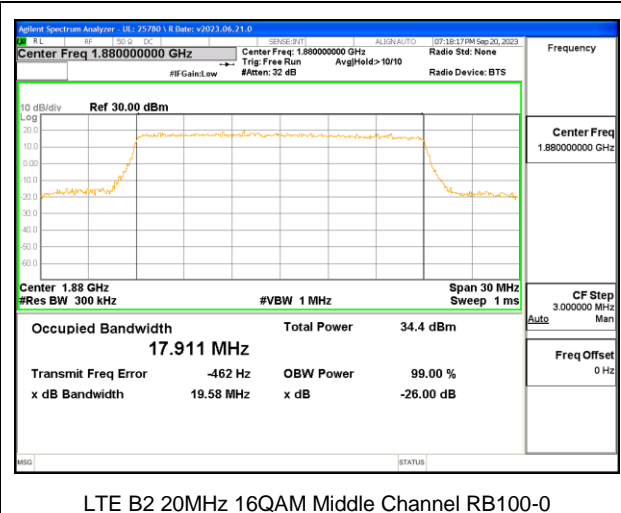
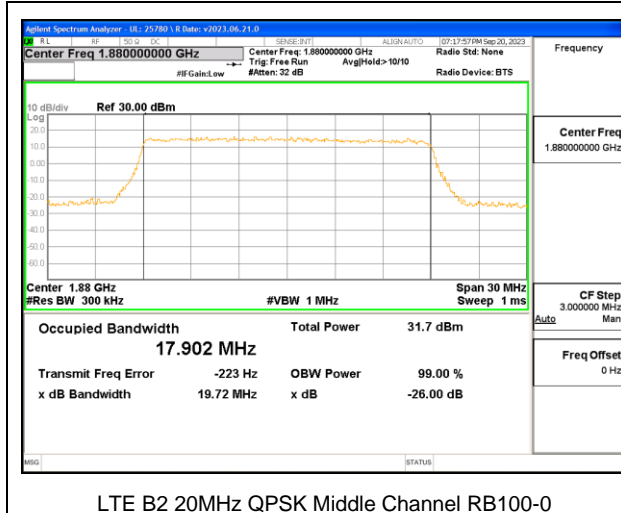

9.1.4. LTE BAND 12

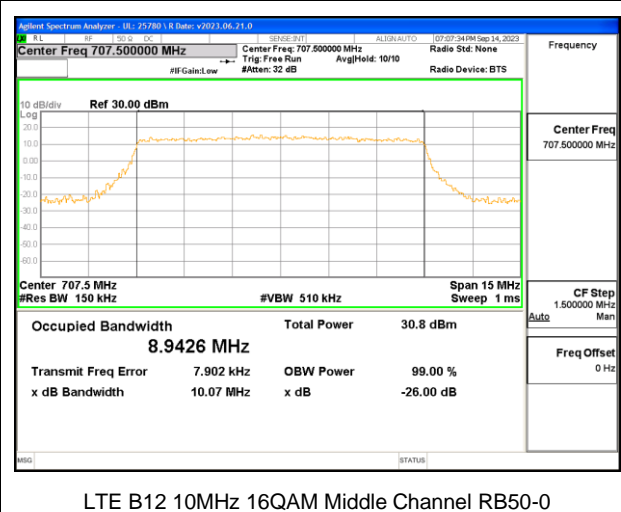
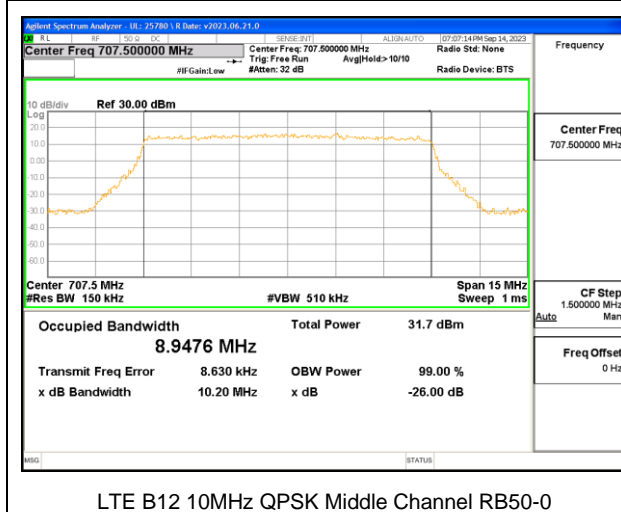

9.1.5. LTE BAND 13

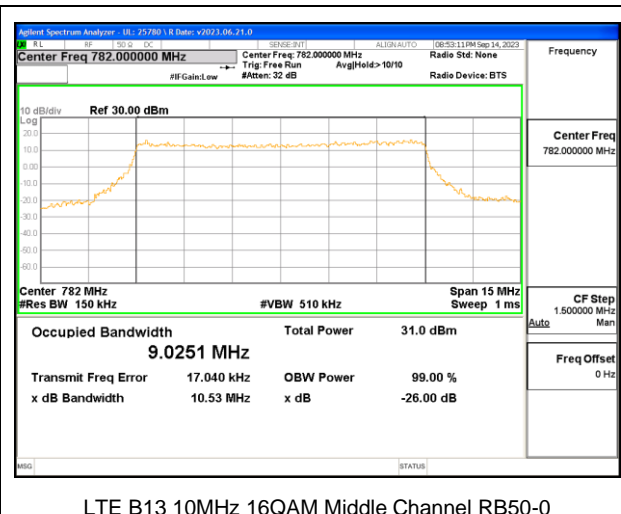
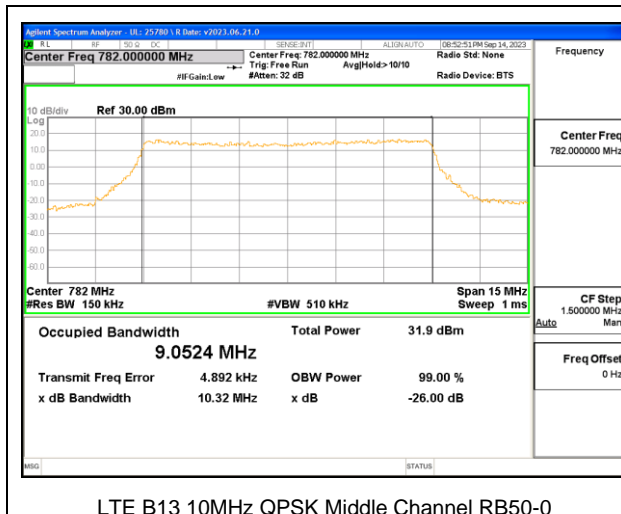

9.1.6. LTE BAND 26 (FCC PART 90S)

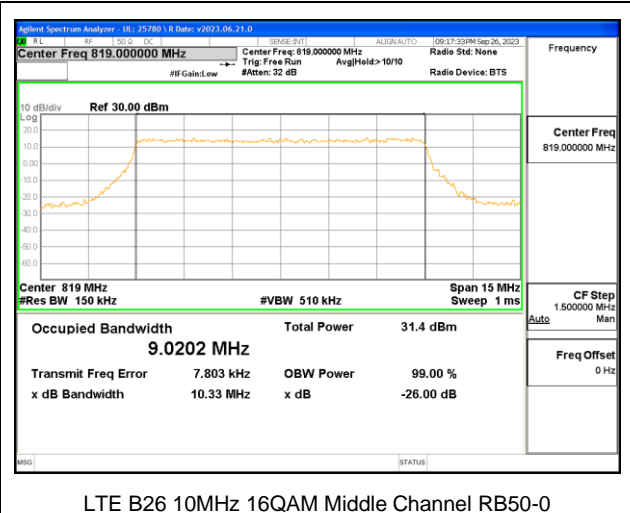
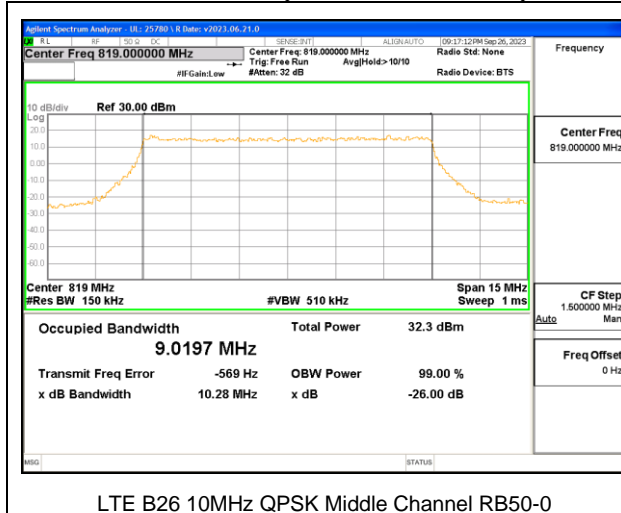

9.1.7. LTE BAND 26 (FCC PART 22)

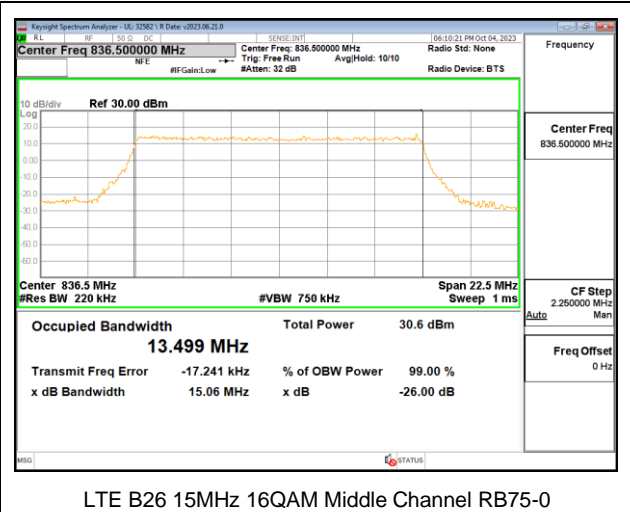
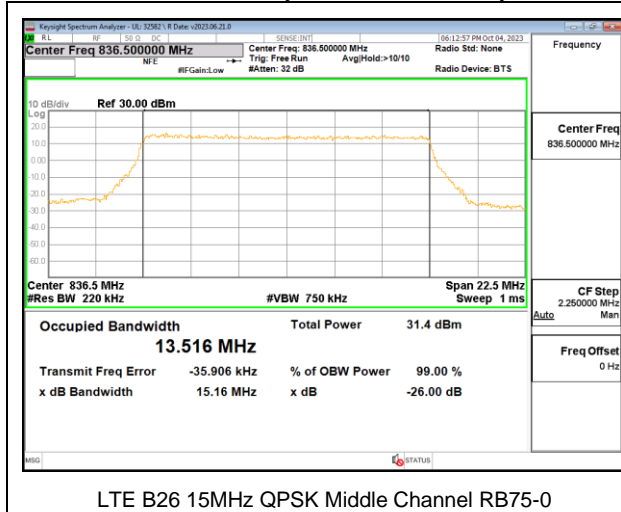

9.1.8. LTE BAND 41

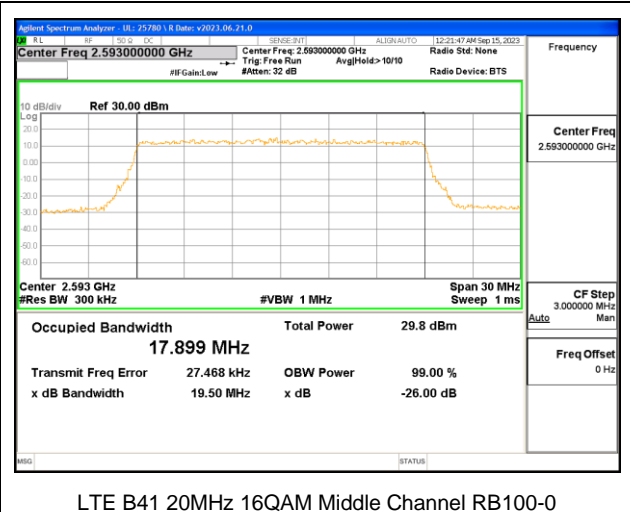
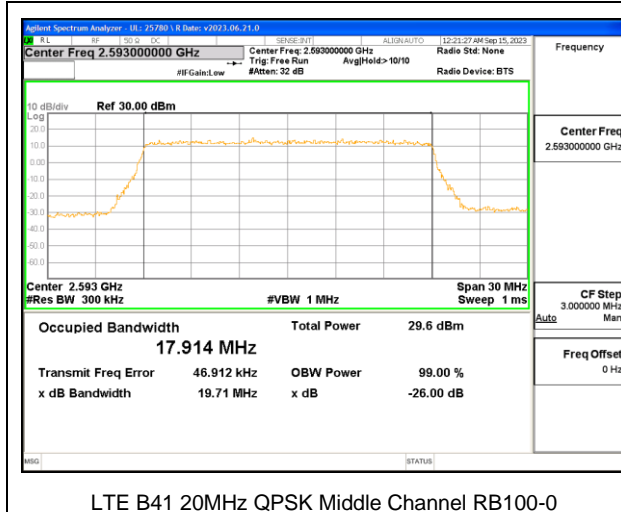

9.1.9. LTE BAND 66

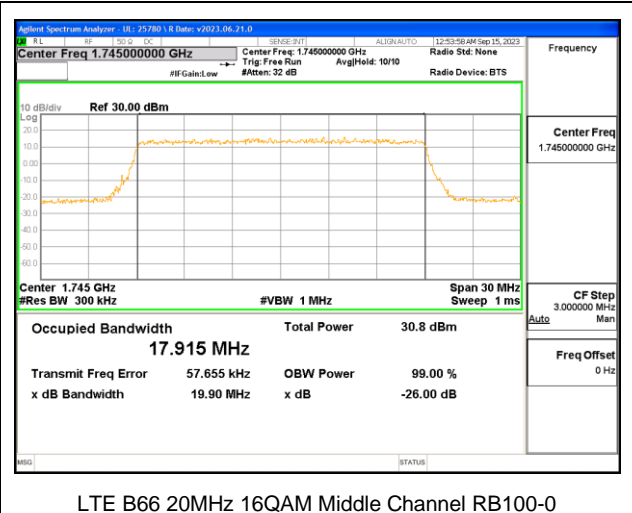
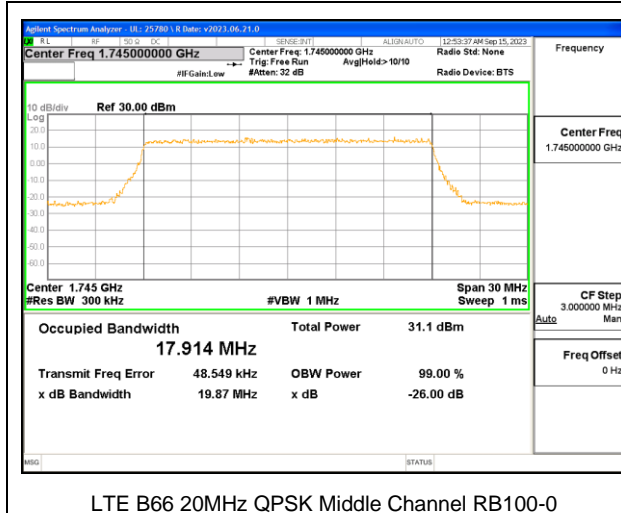

9.2. BAND EDGE AND EMISSION MASK

For Spectrum Emission Mask plots, the Keysight PXA N9030A is configured to sweep with a moving integration window, the width of which can be adjusted to different sizes across the sweep. The window width is configured to be greater than or equal to the required reference bandwidth. The center frequencies of the integration window for the different integration windows was set such that the upper and lower edges of the windows are aligned with the transition points in the reference bandwidths. This is achieved by setting the start / stop frequencies of the window with an offset equal to the reference bandwidth / 2 from the transition point.

TEST PROCEDURE

The transmitter output was connected to a CMW500Test Set and configured to operate at maximum power. The band edge emissions were measured at the required operating frequencies in each band on the Spectrum Analyzer.

For each band edge measurement:

1. Set the spectrum analyzer span to include the block edge frequency.
2. Set a marker to point the corresponding band edge frequency in each test case.
3. Set display line at -13 dBm
4. Set resolution bandwidth to at least 1% of emission bandwidth.

TEST PROCEDURE (FCC LTE BAND 41)

(m)(6) Measurement procedure. Compliance with these rules is based on the use of measurement instrumentation employing a resolution bandwidth of 1 megahertz or greater. However, in the 1 MHz bands immediately outside and adjacent to the frequency block a resolution bandwidth of at least one percent of the emission bandwidth of the fundamental emission of the transmitter may be employed; for mobile digital stations, in the 1 megahertz bands immediately outside and adjacent to the frequency block a resolution bandwidth of at least two percent may be employed, except when the 1 megahertz band is 2495-2496 MHz, in which case a resolution bandwidth of at least one percent may be employed. A narrower resolution bandwidth is permitted in all cases to improve measurement accuracy provided the measured power is integrated over the full required measurement bandwidth (i.e. 1 megahertz or 1 percent of emission bandwidth, as specified; or 1 megahertz or 2 percent for mobile digital stations, except in the band 2495-2496 MHz). The emission bandwidth is defined as the width of the signal between two points, one below the carrier center frequency and one above the carrier center frequency, outside of which all emissions are attenuated at least 26 dB below the transmitter power. With respect to television operations, measurements must be made of the separate visual and aural operating powers at sufficiently frequent intervals to ensure compliance with the rules.

RESULTS

9.2.1. GSM 850

LIMITS

FCC: §22.917

The power of any emission outside of the authorized operating frequency ranges must be attenuated below the transmitting power (P) by a factor of at least $43 + 10 \log (P)$ dB.

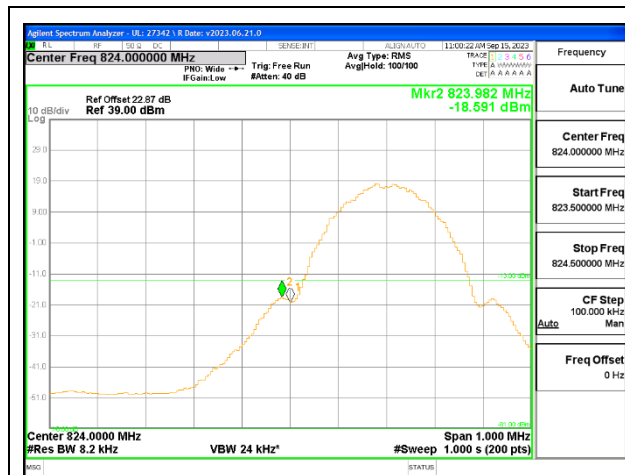

GSM 850 GPRS Low Channel

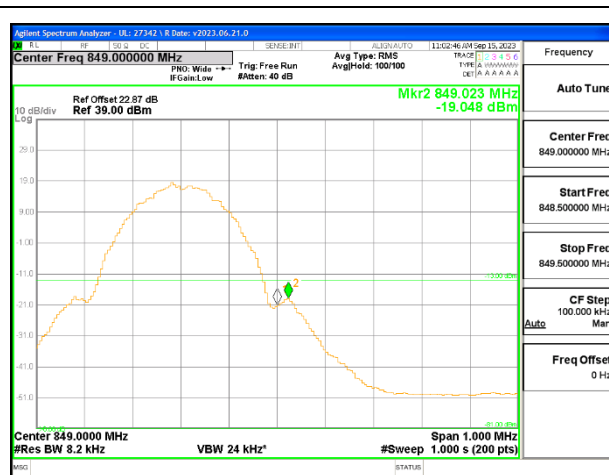

GSM 850 GPRS High Channel

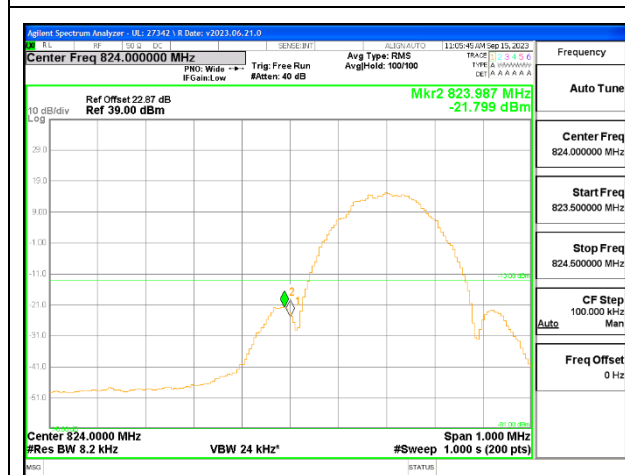

GSM 850 EGPRS Low Channel

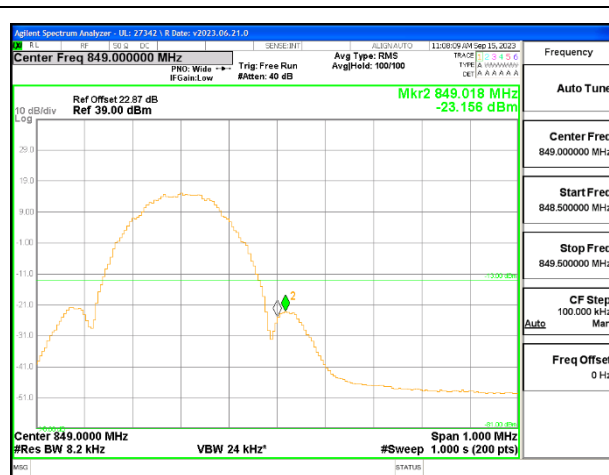

GSM 850 EGPRS High Channel

9.2.2. GSM 1900

LIMITS

FCC: §24.238

The power of any emission outside of the authorized operating frequency ranges must be attenuated below the transmitting power (P) by a factor of at least $43 + 10 \log (P)$ dB.

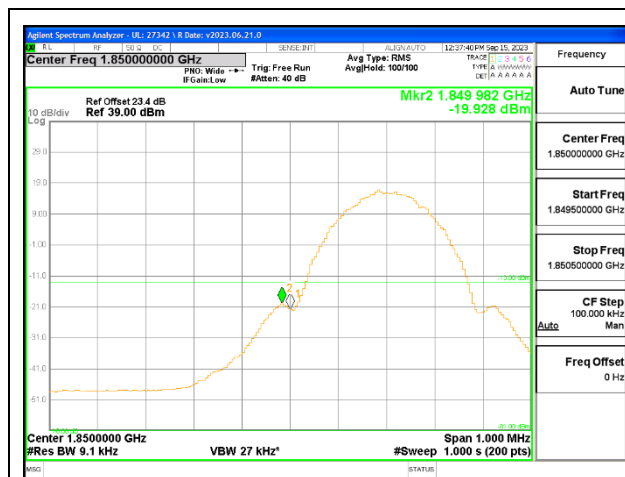

GSM 1900 GPRS Low Channel

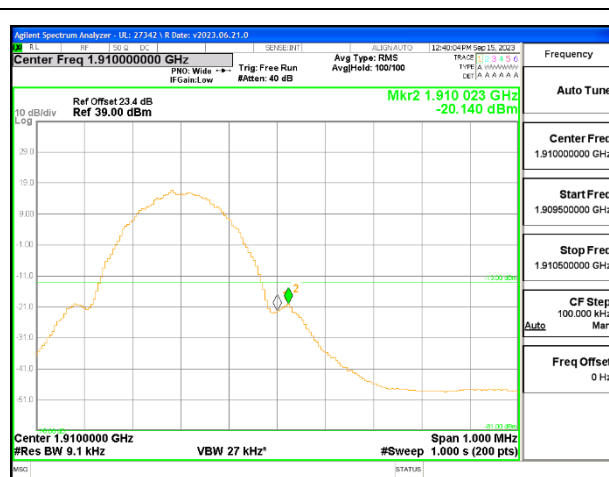

GSM 1900 GPRS High Channel

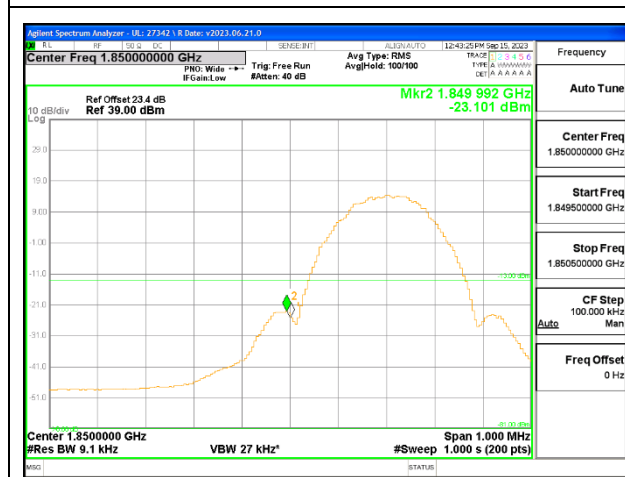

GSM 1900 EGPRS Low Channel

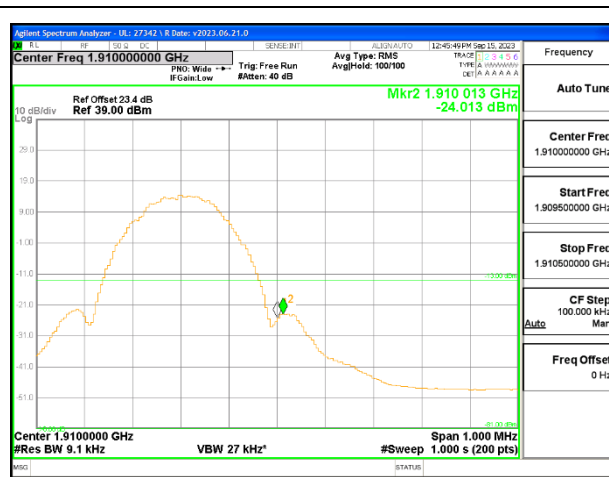

GSM 1900 EGPRS High Channel

9.2.3. WCDMA BAND 5

LIMITS

FCC: §22.917

The power of any emission outside of the authorized operating frequency ranges must be attenuated below the transmitting power (P) by a factor of at least 43 + 10 log (P) dB.

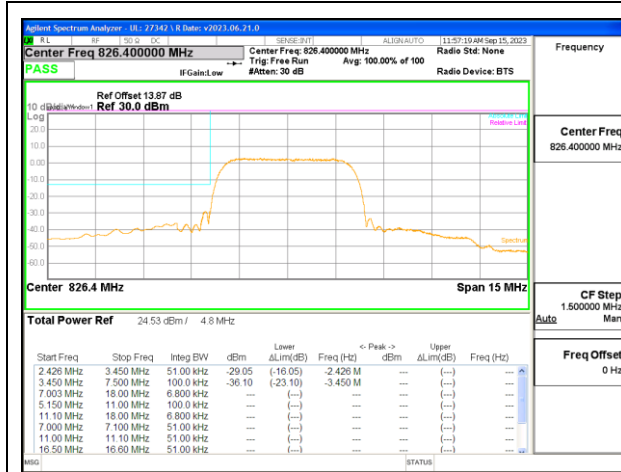

WCDMA Band 5 Rel 99 Low Channel

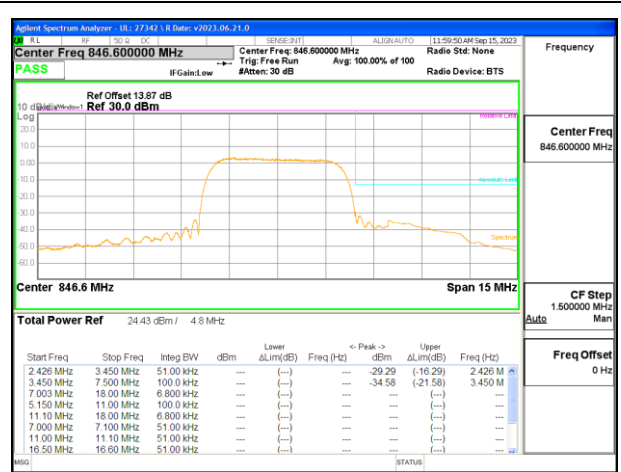

WCDMA Band 5 Rel 99 High Channel

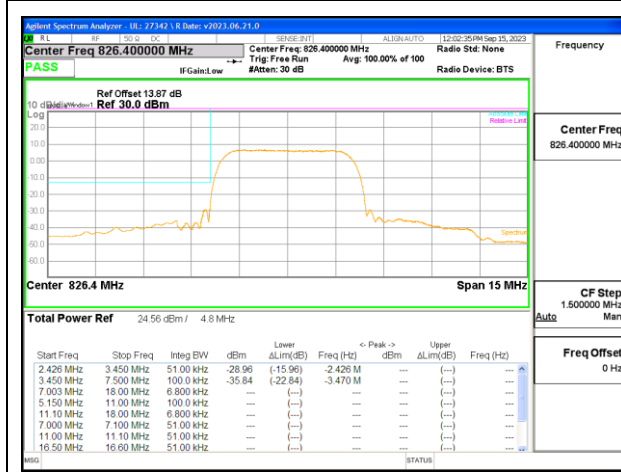

WCDMA Band 5 HSDPA Low Channel

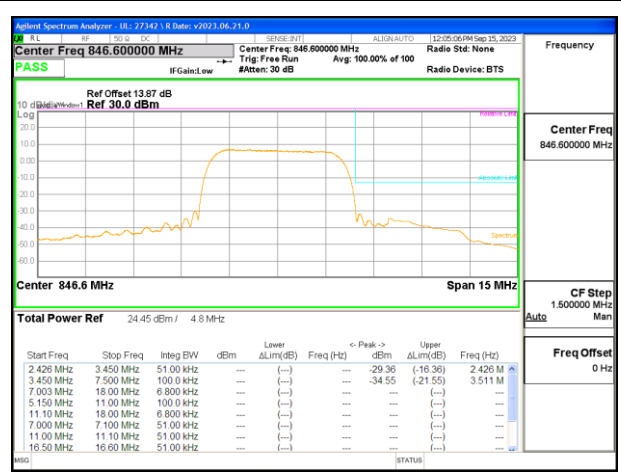

WCDMA Band 5 HSDPA High Channel

9.2.4. WCDMA BAND 2

LIMITS

FCC: §24.238

The power of any emission outside of the authorized operating frequency ranges must be attenuated below the transmitting power (P) by a factor of at least $43 + 10 \log (P)$ dB.



WCDMA Band 2 Rel 99 Low Channel



WCDMA Band 2 Rel 99 High Channel

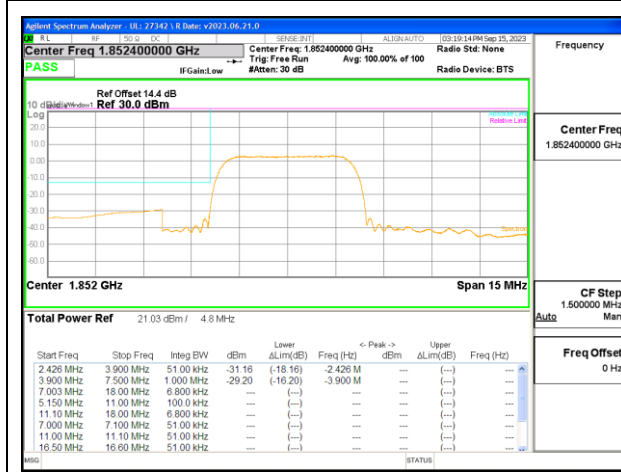

WCDMA Band 2 HSDPA Low Channel

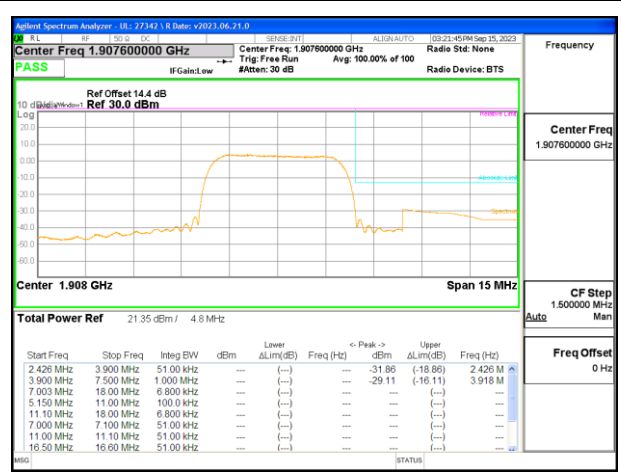

WCDMA Band 2 HSDPA High Channel

9.2.5. WCDMA BAND 4

LIMITS

FCC: §27.53(h)

The power of any emission outside the authorized operating frequency ranges must be attenuated below the transmitting power (P) by a factor of at least 43 + 10 log (P) dB.

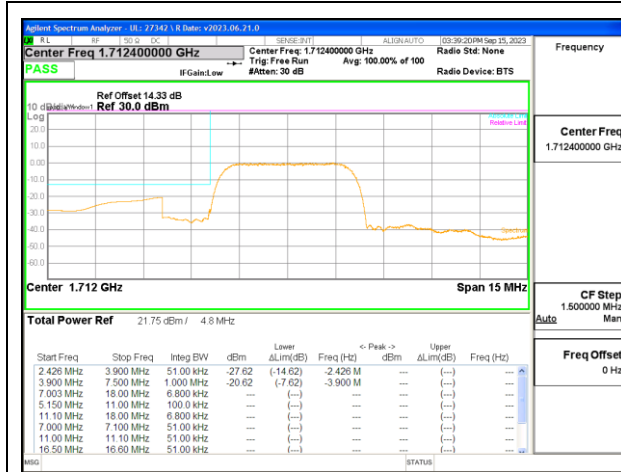

WCDMA Band 4 Rel 99 Low Channel

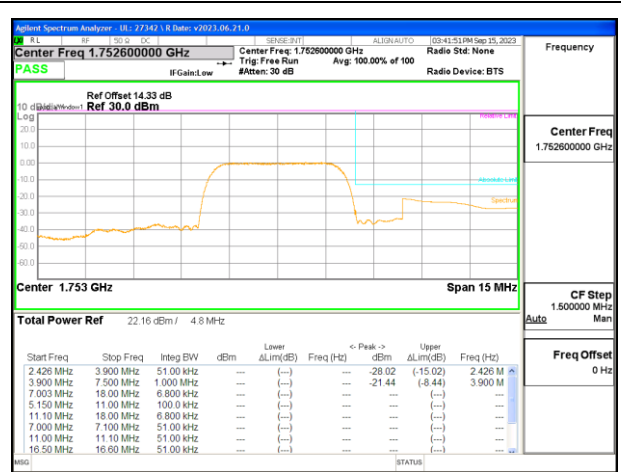

WCDMA Band 4 Rel 99 High Channel

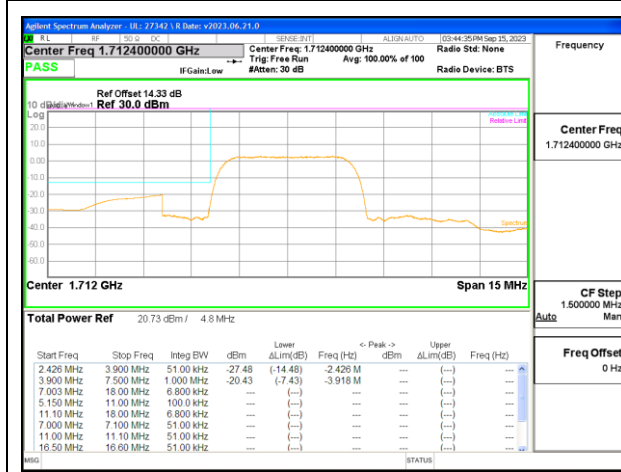

WCDMA Band 4 HSDPA Low Channel

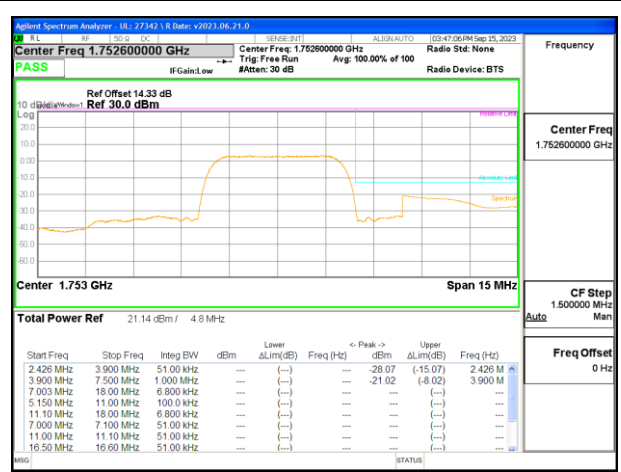

WCDMA Band 4 HSDPA High Channel

9.2.6. LTE BAND 2 BANDEDGE

LIMITS

FCC: §24.238

The power of any emission outside the authorized operating frequency ranges must be attenuated below the transmitting power (P) by a factor of at least 43 + 10 log (P) dB.

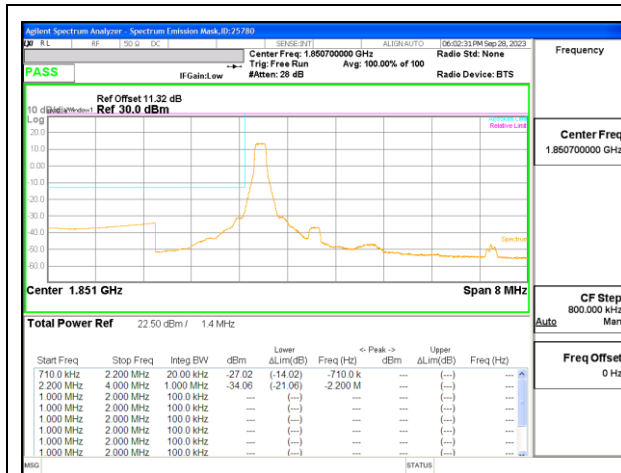

LTE B2 1.4MHz QPSK Low Channel RB1-0

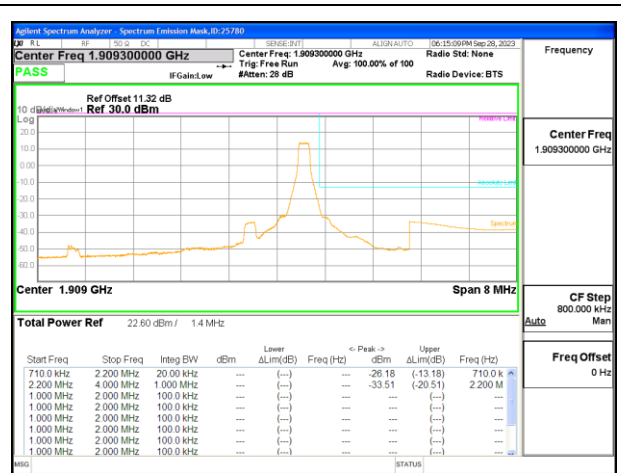

LTE B2 1.4MHz QPSK High Channel RB1-5

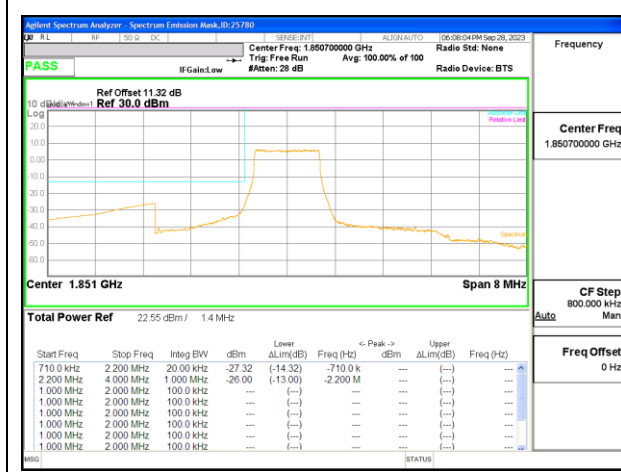

LTE B2 1.4MHz QPSK Low Channel RB6-0

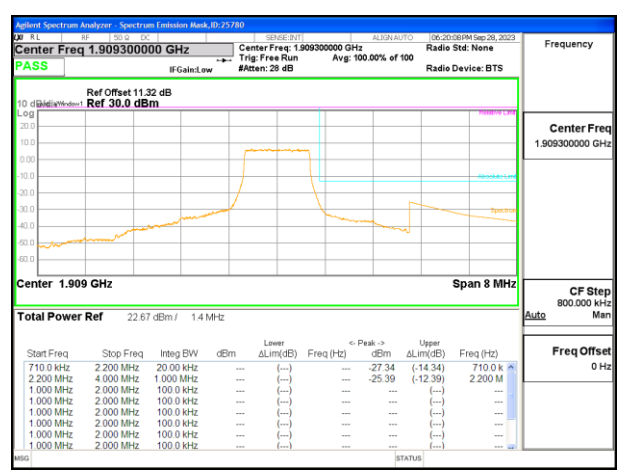

LTE B2 1.4MHz QPSK High Channel RB6-0

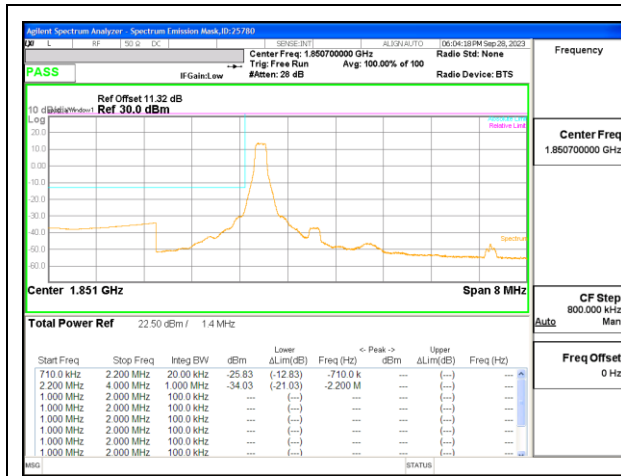

LTE B2 1.4MHz 16QAM Low Channel RB1-0

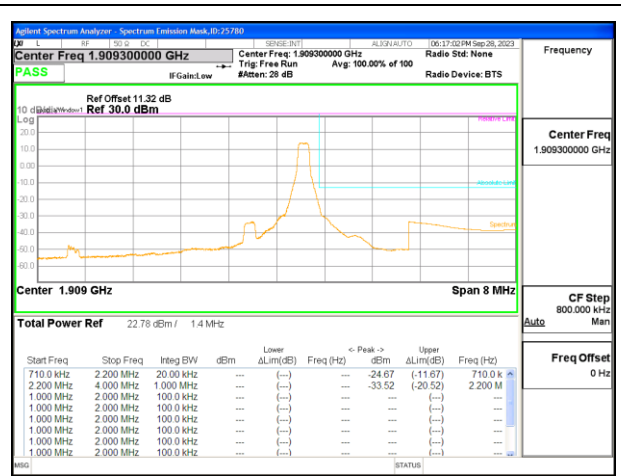

LTE B2 1.4MHz 16QAM High Channel RB1-5

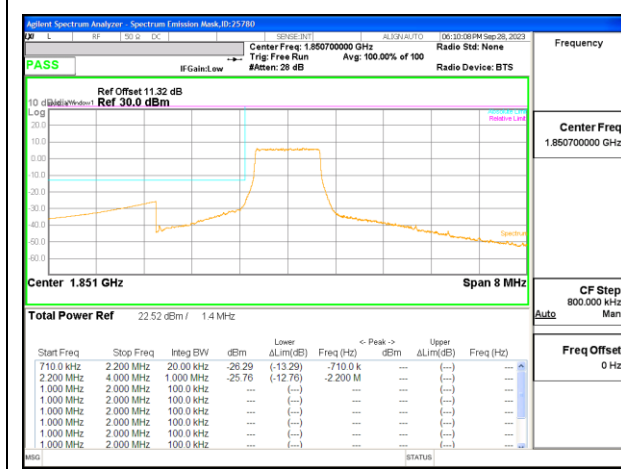

LTE B2 1.4MHz 16QAM Low Channel RB6-0

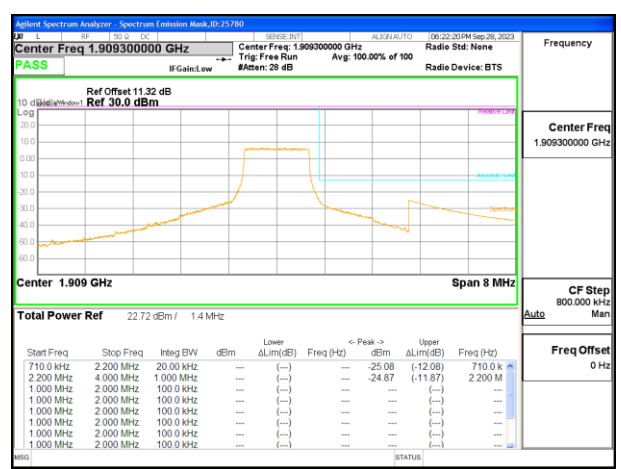

LTE B2 1.4MHz 16QAM High Channel RB6-0

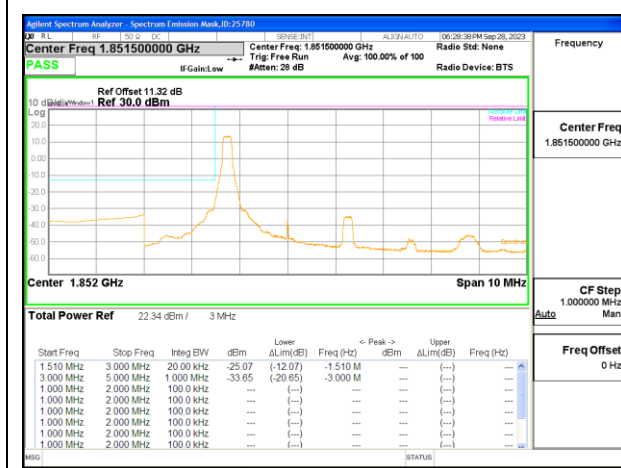

LTE B2 3MHz QPSK Low Channel RB1-0

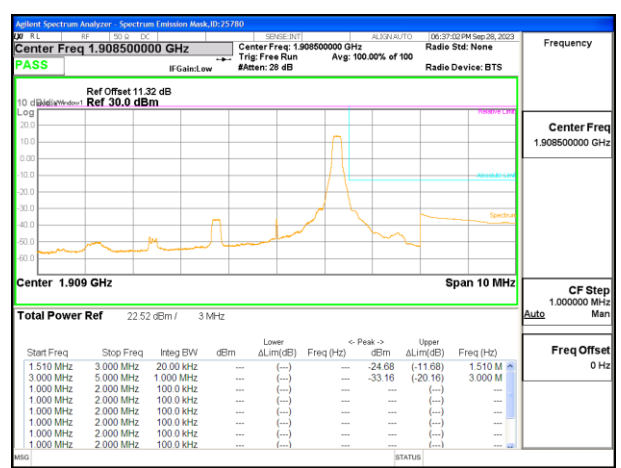

LTE B2 3MHz QPSK High Channel RB1-14

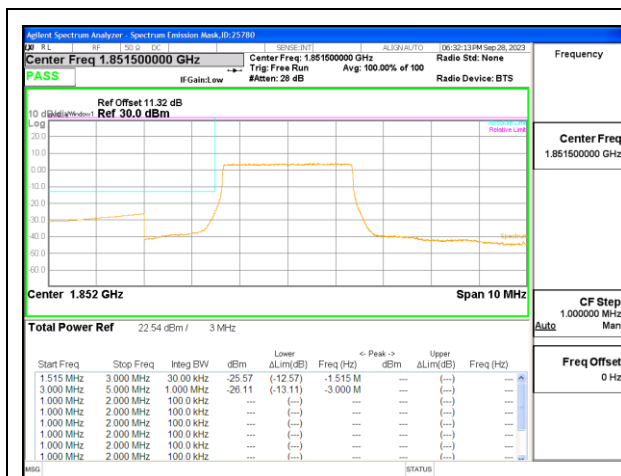

LTE B2 3MHz QPSK Low Channel RB15-0



LTE B2 3MHz QPSK High Channel RB15-0

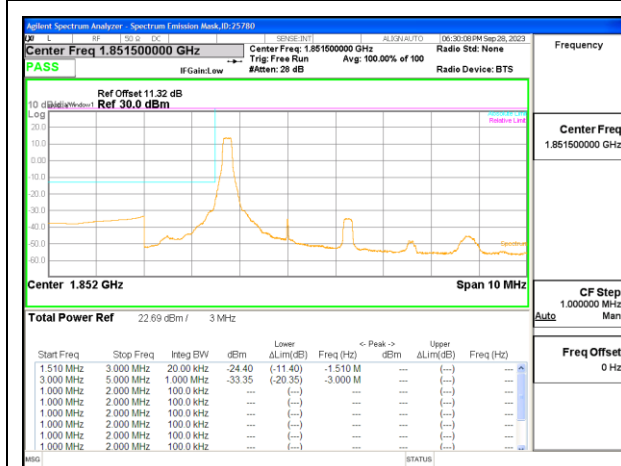

LTE B2 3MHz 16QAM Low Channel RB1-0

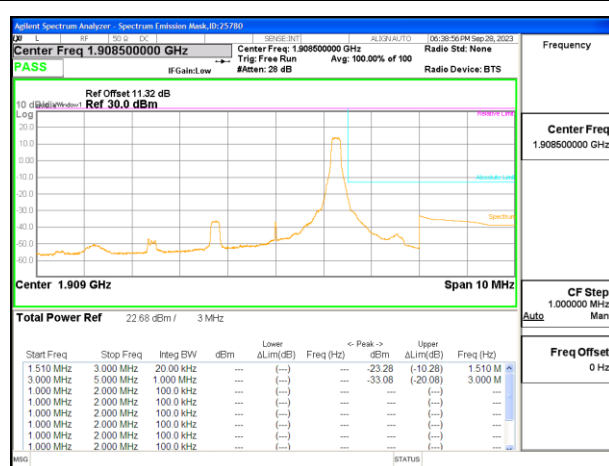

LTE B2 3MHz 16QAM High Channel RB1-14

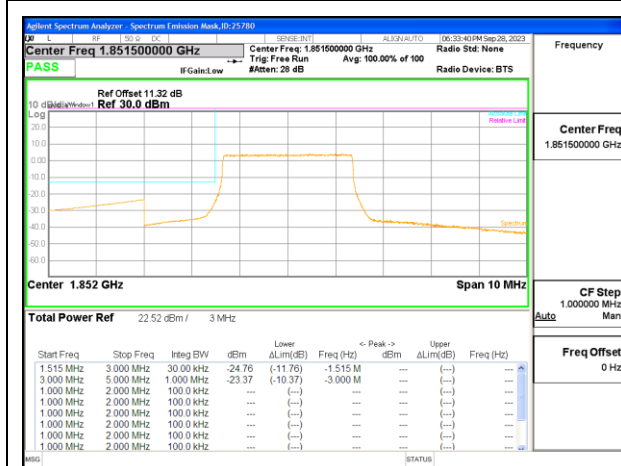

LTE B2 3MHz 16QAM Low Channel RB15-0

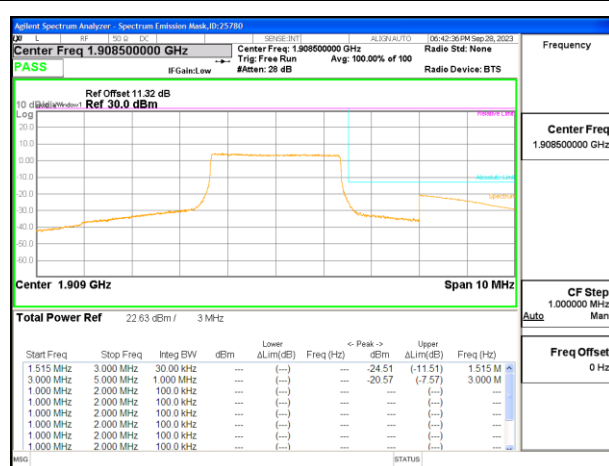

LTE B2 3MHz 16QAM High Channel RB15-0

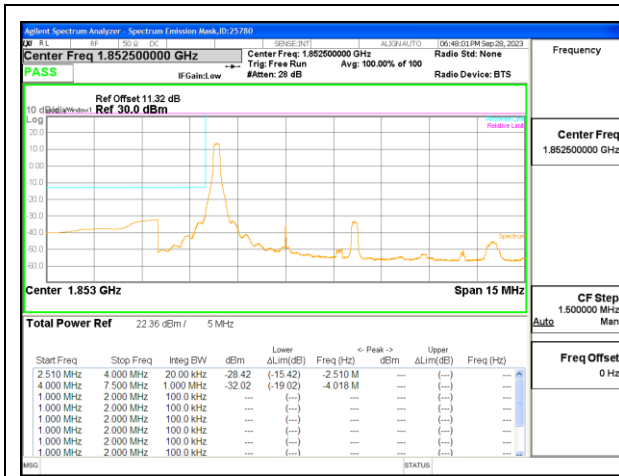

LTE B2 5MHz QPSK Low Channel RB1-0

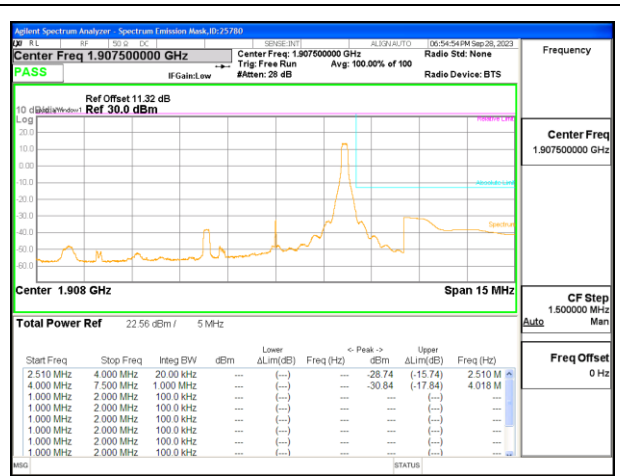

LTE B2 5MHz QPSK High Channel RB1-24

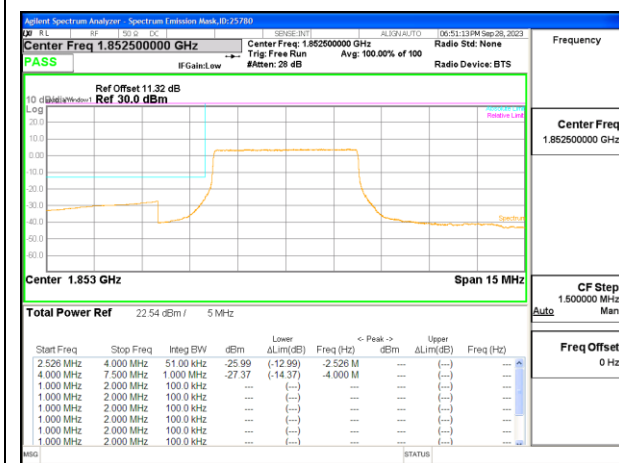

LTE B2 5MHz QPSK Low Channel RB25-0

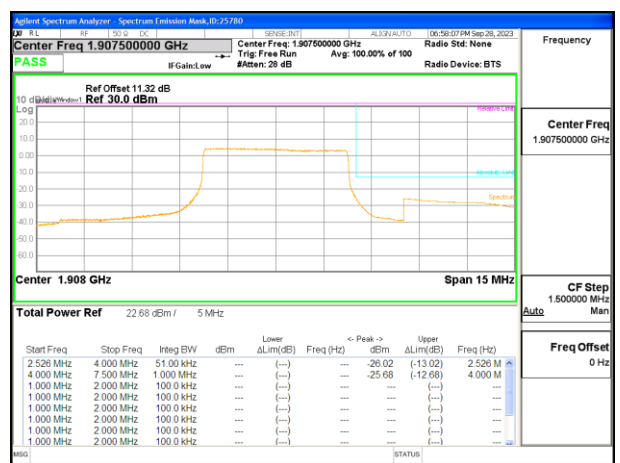

LTE B2 5MHz QPSK High Channel RB25-0

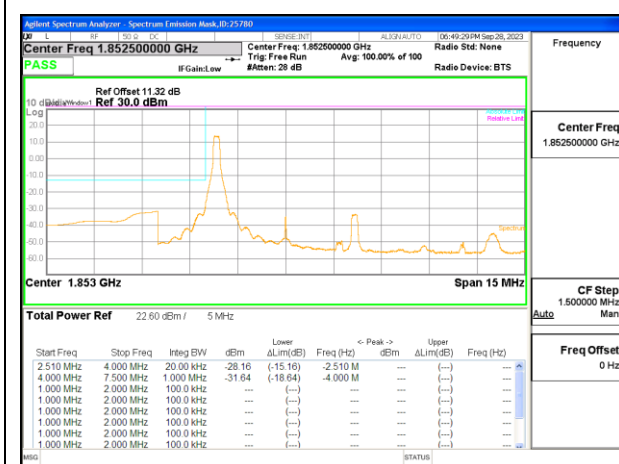

LTE B2 5MHz 16QAM Low Channel RB1-0

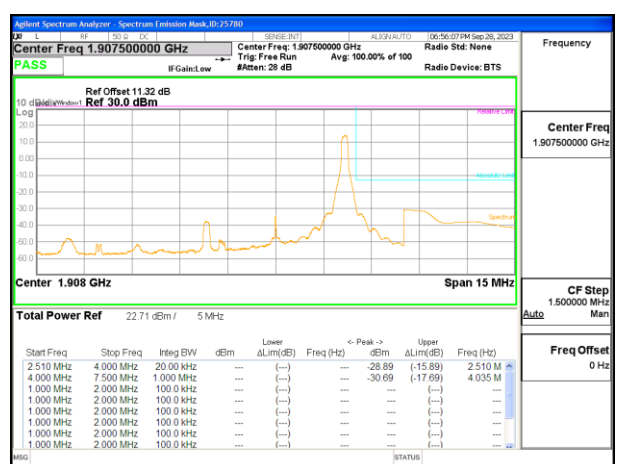

LTE B2 5MHz 16QAM High Channel RB1-24

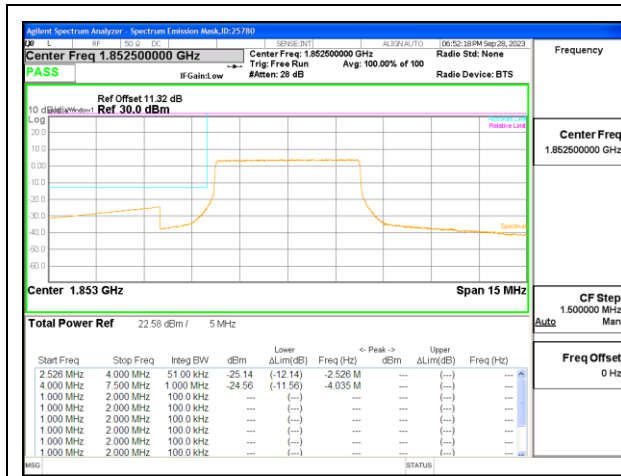

LTE B2 5MHz 16QAM Low Channel RB25-0

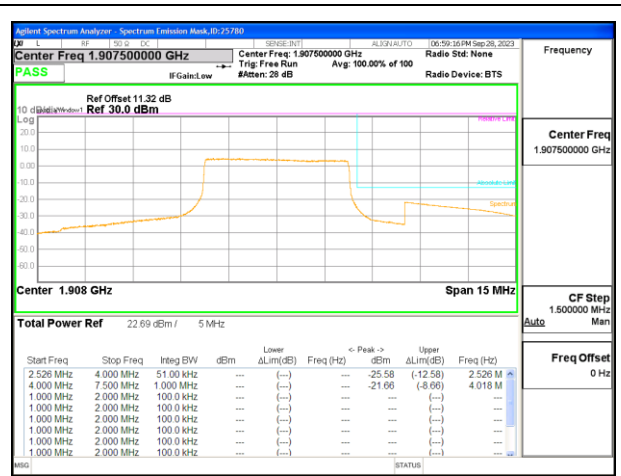

LTE B2 5MHz 16QAM High Channel RB25-0

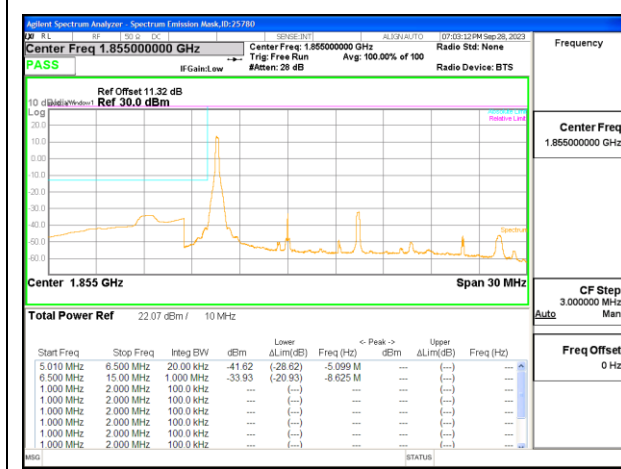

LTE B2 10MHz QPSK Low Channel RB1-0

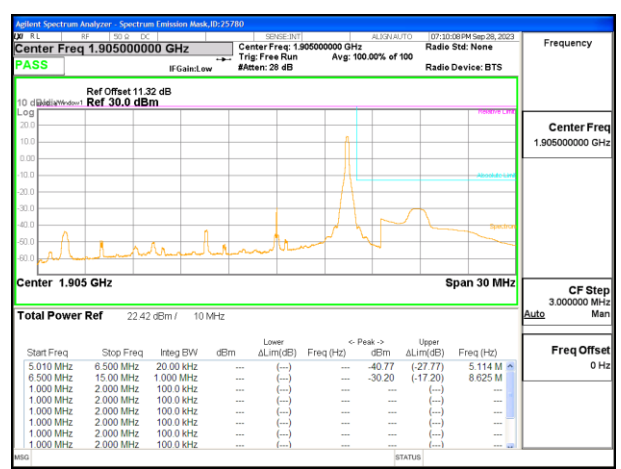

LTE B2 10MHz QPSK High Channel RB1-49

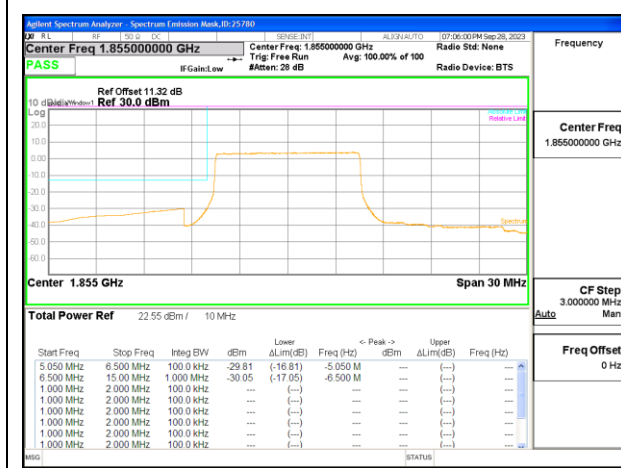

LTE B2 10MHz QPSK Low Channel RB50-0

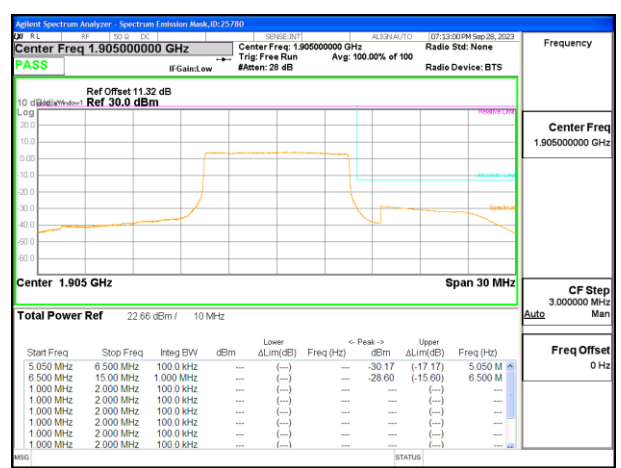

LTE B2 10MHz QPSK High Channel RB50-0