



FCC CFR47 PART 15 SUBPART C

Bluetooth

CERTIFICATION TEST REPORT

FOR

GSM/WCDMA/LTE Phone + BT/BLE, DTS b/g/n and NFC

MODEL NUMBER : SM-A205GN/DS, SM-A205GN

FCC ID: A3LSMA205GN

REPORT NUMBER: 4788869685-E4V2

ISSUE DATE: FEB 26, 2019

Prepared for
SAMSUNG ELECTRONICS CO., LTD.
129 SAMSUNG-RO, YEONGTONG-GU, SUWON-SI,
GYEONGGI-DO, 16677, KOREA

Prepared by
UL Korea, Ltd.
26th floor, 152, Teheran-ro, Gangnam-gu Seoul, 06236, Korea

Suwon Test Site: UL Korea, Ltd. Suwon Laboratory
218 Maeyeong-ro, Yeongtong-gu,
Suwon-si, Gyeonggi-do, 16675, Korea
TEL: (031) 337-9902
FAX: (031) 213-5433



ACCREDITED*

Testing
Laboratory

TL-637

Revision History

<u>Rev.</u>	<u>Issue Date</u>	<u>Revisions</u>	<u>Revised By</u>
V1	02/21/19	Initial issue	Hoonpyo Lee
V2	02/26/19	Updated to address about the TCB's question	Hoonpyo Lee

TABLE OF CONTENTS

1. ATTESTATION OF TEST RESULTS	5
2. TEST METHODOLOGY	6
3. FACILITIES AND ACCREDITATION	6
4. CALIBRATION AND UNCERTAINTY	6
4.1. MEASURING INSTRUMENT CALIBRATION.....	6
4.2. SAMPLE CALCULATION.....	6
4.3. MEASUREMENT UNCERTAINTY	7
5. EQUIPMENT UNDER TEST	8
5.1. DESCRIPTION OF EUT.....	8
5.1. MAXIMUM OUTPUT POWER.....	8
5.2. DESCRIPTION OF AVAILABLE ANTENNAS	8
5.3. WORST-CASE CONFIGURATION AND MODE	8
5.4. DESCRIPTION OF TEST SETUP	9
6. MEASUREMENT METHODS	11
7. TEST AND MEASUREMENT EQUIPMENT	12
8. REFERENCE MEASUREMENT RESULTS.....	13
8.1. ON TIME AND DUTY CYCLE RESULTS.....	13
8.2. 20 dB AND 99% BANDWIDTH.....	14
8.2.1. BASIC DATA RATE GFSK MODULATION.....	14
8.2.2. ENHANCED DATA RATE Pi/4-DQPSK MODULATION.....	14
8.2.3. ENHANCED DATA RATE 8PSK MODULATION	14
8.2.4. 20 dB AND 99% BANDWIDTH PLOTS.....	15
9. SUMMARY TABLE	18
10. ANTENNA PORT TEST RESULTS	19
10.1. HOPPING FREQUENCY SEPARATION	19
10.2. NUMBER OF HOPPING CHANNELS.....	20
10.3. AVERAGE TIME OF OCCUPANCY.....	24
10.4. OUTPUT POWER.....	32
10.4.1. BASIC DATA RATE GFSK MODULATION.....	32
10.4.2. ENHANCED DATA RATE Pi/4-DPSK MODULATION	32
10.4.3. ENHANCED DATA RATE 8PSK MODULATION	32
10.4.4. OUTPUT POWER PLOTS.....	33
10.5. AVERAGE POWER.....	36

10.5.1.	BASIC DATA RATE GFSK MODULATION.....	36
10.5.2.	ENHANCED DATA RATE PI/4-DQPSK MODULATION	36
10.5.3.	ENHANCED DATA RATE 8PSK MODULATION	36
10.6.	CONDUCTED SPURIOUS EMISSIONS.....	37
10.6.1.	BASIC DATA RATE GFSK MODULATION.....	38
10.6.2.	ENHANCED DATA RATE PI/4-DQPSK MODULATION	42
10.6.3.	ENHANCED DATA RATE 8PSK MODULATION	46
11.	RADIATED TEST RESULTS	50
11.1.	LIMITS AND PROCEDURE	50
11.2.	TRANSMITTER ABOVE 1 GHz	52
11.2.1.	BASIC DATA RATE GFSK MODULATION.....	52
11.2.2.	ENHANCED DATA RATE 8PSK MODULATION	62
11.3.	WORST-CASE BELOW 1 GHz.....	72
12.	AC POWER LINE CONDUCTED EMISSIONS	74
13.	SETUP PHOTOS	79

1. ATTESTATION OF TEST RESULTS

COMPANY NAME: SAMSUNG ELECTRONICS CO., LTD.
EUT DESCRIPTION: GSM/WCDMA/LTE Phone + BT/BLE, DTS b/g/n and NFC
MODEL NUMBER: SM-A205GN/DS, SM-A205GN
SERIAL NUMBER: R38K909WK7M, R38M10DAJ7K (RADIATED);
5200499a529db5c1 (CONDUCTED)
DATE TESTED: JAN 21, 2018 – FEB 26, 2019

APPLICABLE STANDARDS	
STANDARD	TEST RESULTS
CFR 47 Part 15 Subpart C	Pass

UL Korea, Ltd. tested the above equipment in accordance with the requirements set forth in the above standards. All indications of Pass/Fail in this report are opinions expressed by UL Korea, Ltd. based on interpretations and/or observations of test results. Measurement Uncertainties were not taken into account and are published for informational purposes only. The test results show that the equipment tested is capable of demonstrating compliance with the requirements as documented in this report.

Note: The results documented in this report apply only to the tested sample, under the conditions and modes of operation as described herein. This document JUN not be altered or revised in any way unless done so by UL Korea, Ltd. and all revisions are duly noted in the revisions section. Any alteration of this document not carried out by UL Korea, Ltd. will constitute fraud and shall nullify the document. This report must not be used by the client to claim product certification, approval, or endorsement by IAS, any agency of the Federal Government, or any agency of any government.

Approved & Released For
UL Korea, Ltd. By:

Tested By:



SungGil Park
Suwon Lab Engineer
UL Korea, Ltd.

Hoonpyo Lee
Suwon Lab Engineer
UL Korea, Ltd.

2. TEST METHODOLOGY

The tests documented in this report were performed in accordance with following methods.

1. FCC CFR 47 Part 2.
2. FCC CFR 47 Part 15.
3. 558074 D01 15.247 Meas Guidance v05r01
4. ANSI C63.10-2013.

3. FACILITIES AND ACCREDITATION

The test sites and measurement facilities used to collect data are located at 218 Maeyeong-ro, Yeongtong-gu, Suwon-si, Gyeonggi-do, 16675, Korea. Line conducted emissions are measured only at the 218 address. The following table identifies which facilities were utilized for radiated emission measurements documented in this report. Specific facilities are also identified in the test results sections.

218 Maeyeong-ro	
<input checked="" type="checkbox"/>	Chamber 1
<input checked="" type="checkbox"/>	Chamber 2
<input type="checkbox"/>	Chamber 3

UL Korea, Ltd. is accredited by IAS, Laboratory Code TL-637. The full scope of accreditation can be viewed at <http://www.iasonline.org/PDF/TL/TL-637.pdf>.

4. CALIBRATION AND UNCERTAINTY

4.1. MEASURING INSTRUMENT CALIBRATION

The measuring equipment utilized to perform the tests documented in this report has been calibrated in accordance with the manufacturer's recommendations, and is traceable to recognized national standards.

4.2. SAMPLE CALCULATION

Where relevant, the following sample calculation is provided:

$$\begin{aligned} \text{Field Strength (dBuV/m)} &= \text{Measured Voltage (dBuV)} + \text{Antenna Factor (dB/m)} + \\ &\text{Cable Loss (dB)} - \text{Preamplifier Gain (dB)} \\ 36.5 \text{ dBuV} + 18.7 \text{ dB/m} + 0.6 \text{ dB} - 26.9 \text{ dB} &= 28.9 \text{ dBuV/m} \end{aligned}$$

4.3. MEASUREMENT UNCERTAINTY

Where relevant, the following measurement uncertainty levels have been estimated for tests performed on the apparatus:

PARAMETER	UNCERTAINTY
Conducted Disturbance, 0.15 to 30 MHz	2.32 dB
Radiated Disturbance, Below 1GHz	3.86 dB
Radiated Disturbance, Above 1 GHz	5.97 dB

Uncertainty figures are valid to a confidence level of 95%.

5. EQUIPMENT UNDER TEST

5.1.DESCRPTION OF EUT

The EUT is a GSM/WCDMA/LTE Phone + BT/BLE, DTS b/g/n and NFC.
 This test report addresses the DSS (BT) operational mode.

5.1.MAXIMUM OUTPUT POWER

The transmitter has a maximum conducted output power as follows:

Frequency Range [MHz]	Mode	Power Mode	Output Power [dBm]	Output Power [mW]
2402 - 2480	Basic GFSK	Average	8.851	7.675
		Peak	9.620	9.162
	Enhanced Pi/4-DPSK	Average	7.336	5.415
		Peak	9.870	9.705
	Enhanced 8PSK	Average	7.363	5.449
		Peak	10.843	12.142

5.2.DESCRPTION OF AVAILABLE ANTENNAS

The radio utilizes an internal antenna, with a maximum gain of -0.53 dBi.

5.3.WORST-CASE CONFIGURATION AND MODE

Radiated emission below 1GHz and power line conducted emission were performed with the EUT set to transmit at the channel with highest output power as worst-case scenario.

Radiated emission above 1GHz was performed with the EUT set to transmit low/mid/high channels.

The fundamental of the EUT was investigated in three orthogonal orientations X, Y and Z it was determined that Y orientation was worst-case orientation; therefore, all final radiated testing was performed with the EUT in Y orientation.

Note: GFSK, Pi/4-DQPSK, 8PSK average Power are all investigated, The GFSK & 8PSK Power are the worst case. Testing is based on this mode to showing compliance. For average power data please refer to section 9.5. All radiated and power line conducted tests were performed connected with earphone and charger for evaluation of worst case mode.

5.4.DESCRPTION OF TEST SETUP

SUPPORT EQUIPMENT

Support Equipment List				
Description	Manufacturer	Model	Serial Number	FCC ID
Charger	SAMSUNG	EP-TA200	R37M15H5WM1SE3	N/A
Data Cable	SAMSUNG	EP-DR140AWE	N/A	N/A
Earphone	SAMSUNG	EHS61ASFWE	N/A	N/A

I/O CABLE

I/O Cable List						
Cable No	Port	# of identical ports	Connector Type	Cable Type	Cable Length (m)	Remarks
1	DC Power	1	C Type	Shielded	1.1m	N/A
2	Audio	2	Mini-Jack	Unshielded	1.2m	N/A

TEST SETUP

The EUT is continuously communicating to the Bluetooth tester during the tests.
 Test software enable BT communications.

SETUP DIAGRAM FOR TESTS (CONDUCTED TEST SETUP)

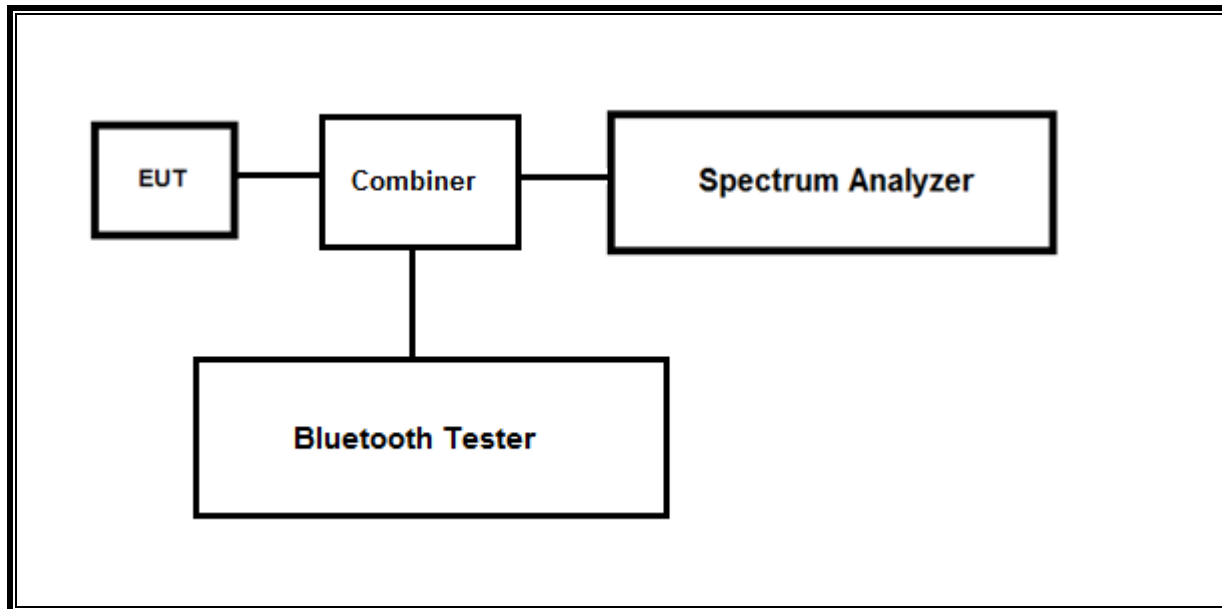

SETUP DIAGRAM FOR TESTS (RADIATED TEST SETUP)

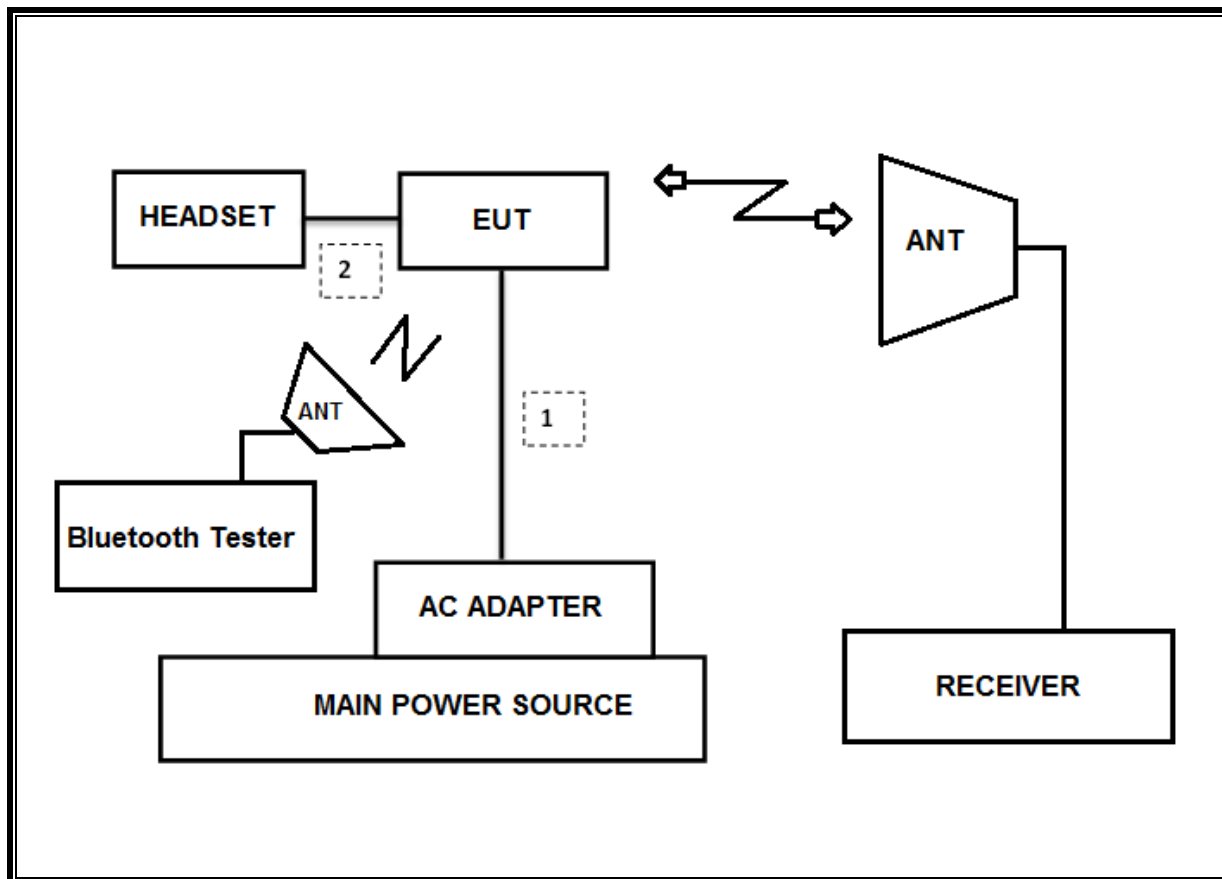

6. MEASUREMENT METHODS

20dB BW : ANSI C63.10, Section 6.9.2

99% BW : ANSI C63.10, Section 6.9.3

HOPPING FREQUENCY SEPARATION : ANSI C63.10, Section 7.8.2

NUMBER OF HOPPING CHANNELS : ANSI C63.10, Section 7.8.3

AVERAGE TIME OF OCCUPANCY : ANSI C63.10, Section 7.8.4

OUTPUT POWER : ANSI C63.10, Section 7.8.5.

Out-of-band EMISSIONS (Conducted) : ANSI C63.10, Section 7.8.6, 7.8.8

Out-of-band EMISSIONS IN NON-RESTRICTED BANDS: ANSI C63.10, Section 6.

Out-of-band EMISSIONS IN RESTRICTED BANDS : ANSI C63.10, Section 6.

AC Power Line Conducted Emission : ANSI C63.10-2013, Section 6.2.

7. TEST AND MEASUREMENT EQUIPMENT

The following test and measurement equipment was utilized for the tests documented in this report:

Test Equipment List				
Description	Manufacturer	Model	S/N	Cal Due
Antenna, Bilog, 30MHz-1GHz	SCHWARZBECK	VULB9163	750	08-04-20
Antenna, Bilog, 30MHz-1GHz	SCHWARZBECK	VULB9163	749	08-04-20
Antenna, Bilog, 30MHz-1GHz	SCHWARZBECK	VULB9163	845	08-04-20
Antenna, Loop, 9kHz-30MHz	R&S	HFH2-Z2	100418	10-26-19
Antenna, Horn, 18 GHz	ETS	3115	00167211	08-04-20
Antenna, Horn, 18 GHz	ETS	3115	00161451	08-04-20
Antenna, Horn, 18 GHz	ETS	3117	00168724	08-04-20
Antenna, Horn, 18 GHz	ETS	3117	00168717	08-04-20
Antenna, Horn, 18 GHz	ETS	3117	00205959	08-04-20
Antenna, Horn, 40 GHz	ETS	3116C	00166155	12-04-19
Antenna, Horn, 40 GHz	ETS	3116C	00168645	12-04-19
Antenna, Horn, 40 GHz	ETS	3116C-PA	00168841	08-09-19
Preamplifier, 1000 MHz	Sonoma	310N	341282	08-07-19
Preamplifier, 1000 MHz	Sonoma	310N	351741	08-07-19
Preamplifier, 1000 MHz	Sonoma	310N	370599	08-06-19
Preamplifier, 18 GHz	Miteq	AFS42-00101800-25-S-42	1876511	08-07-19
Preamplifier, 18 GHz	Miteq	AFS42-00101800-25-S-42	1896138	08-07-19
Preamplifier, 18 GHz	Miteq	AFS42-00101800-25-S-42	2029169	08-07-19
Spectrum Analyzer, 44 GHz	Agilent / HP	N9030A	MY54170614	08-07-19
Spectrum Analyzer, 44 GHz	Agilent / HP	N9030A	MY54490312	08-06-19
Average Power Sensor	Agilent / HP	U2000	MY54270007	08-07-19
Bluetooth Tester	TESCOM	TC-3000C	3000C000546	08-07-19
Combiner	WEINCHEL	1575	2152	08-08-19
Attenuator	PASTERNAK	PE7087-10	A001	08-08-19
Attenuator	PASTERNAK	PE7087-10	A008	08-08-19
Attenuator	PASTERNAK	PE7087-10	2	08-07-19
EMI Test Receive, 40 GHz	R&S	ESU40	100439	08-06-19
EMI Test Receive, 40 GHz	R&S	ESU40	100457	08-06-19
EMI Test Receive, 44 GHz	R&S	ESW44	101590	08-06-19
EMI Test Receive, 3 GHz	R&S	ESR3	101832	08-06-19
Low Pass Filter 5GHz	Micro-Tronics	LPS17541	009	08-07-19
Low Pass Filter 5GHz	Micro-Tronics	LPS17541	015	08-07-19
Low Pass Filter 5GHz	Micro-Tronics	LPS17541	020	08-06-19
High Pass Filter 3GHz	Micro-Tronics	HPM17543	010	08-07-19
High Pass Filter 3GHz	Micro-Tronics	HPM17543	015	08-07-19
High Pass Filter 3GHz	Micro-Tronics	HPM17543	020	08-06-19
High Pass Filter 6GHz	Micro-Tronics	HPS17542	009	08-07-19
High Pass Filter 6GHz	Micro-Tronics	HPS17542	016	08-07-19
High Pass Filter 6GHz	Micro-Tronics	HPS17542	021	08-06-19
LISN	R&S	ENV-216	101837	08-09-19
UL Software				
Description	Manufacturer	Model	Version	
Radiated software	UL	UL EMC	Ver 9.5	

8. REFERENCE MEASUREMENT RESULTS

8.1.ON TIME AND DUTY CYCLE RESULTS

LIMITS

None: for reporting purposes only.

Mode	ON Time B [msec]	Period [msec]	Duty Cycle x [linear]	Duty Cycle [%]	Duty Cycle Correction Factor [dB]	1/T Minimum VBW [kHz]
2400MHz Bands						
BT	2.879	3.751	0.768	76.8%	1.15	0.347



8.2.20 dB AND 99% BANDWIDTH

LIMITS

None; for reporting purposes only.

TEST PROCEDURE

The transmitter output is connected to a spectrum analyzer. The RBW is set to $\geq 1\%$ of the 20 dB bandwidth. The VBW is set to \geq RBW. The sweep time is coupled.

RESULTS

8.2.1. BASIC DATA RATE GFSK MODULATION

Channel	Frequency [MHz]	20 dB Bandwidth [MHz]	99% Bandwidth [kHz]
Low	2402	1.041	938.06
Mid	2441	1.037	904.84
High	2480	1.041	903.98
Worst		1.041	938.06

8.2.2. ENHANCED DATA RATE Pi/4-DQPSK MODULATION

Channel	Frequency [MHz]	20 dB Bandwidth [MHz]	99% Bandwidth [MHz]
Low	2402	1.334	1.163
Mid	2441	1.339	1.165
High	2480	1.344	1.167
Worst		1.344	1.167

8.2.3. ENHANCED DATA RATE 8PSK MODULATION

Channel	Frequency [MHz]	20 dB Bandwidth [MHz]	99% Bandwidth [MHz]
Low	2402	1.303	1.164
Mid	2441	1.275	1.163
High	2480	1.274	1.166
Worst		1.303	1.166

8.2.4. 20 dB AND 99% BANDWIDTH PLOTS

GFSK BANDWIDTH

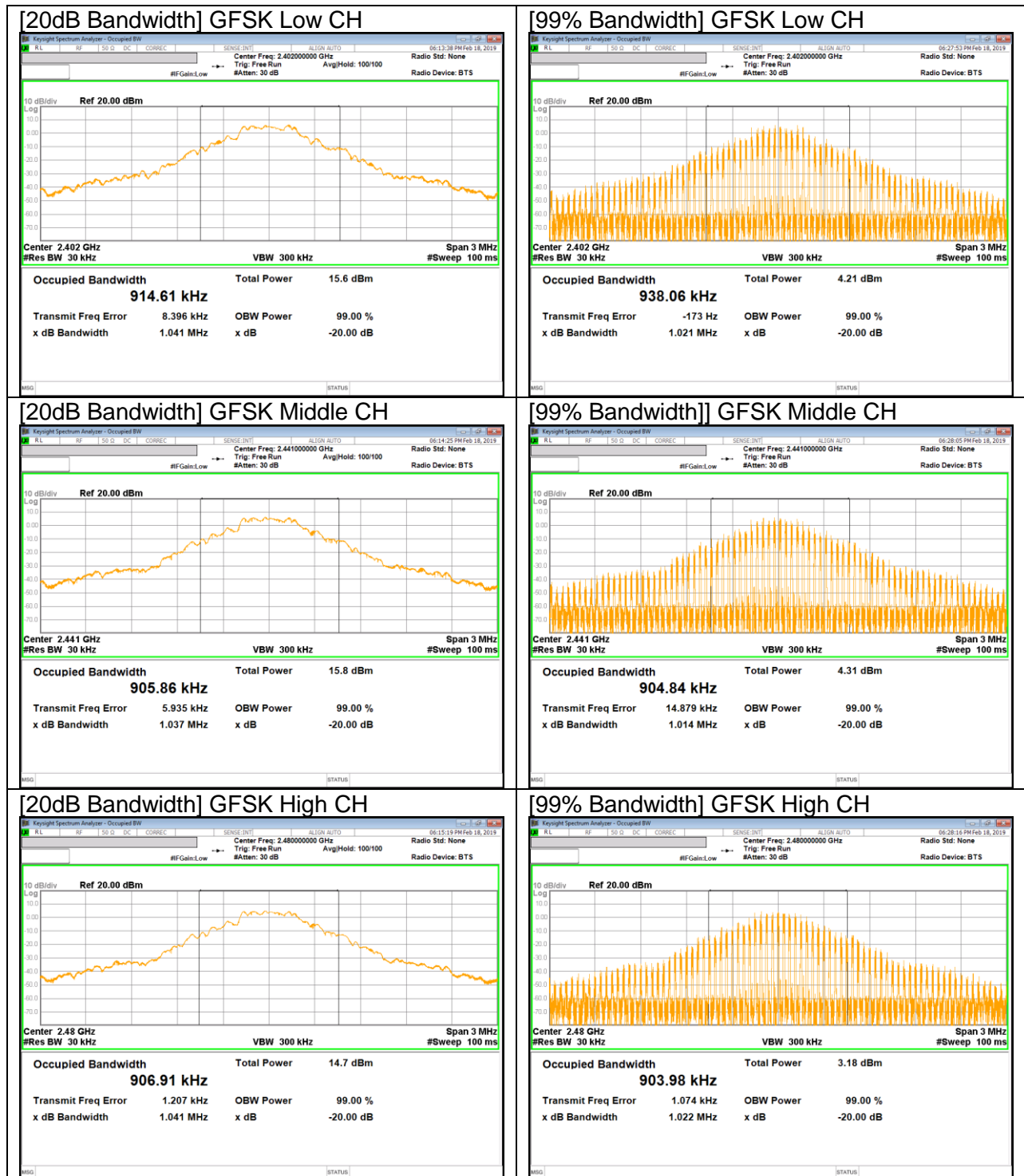

Pi/4-DQPSK BANDWIDTH

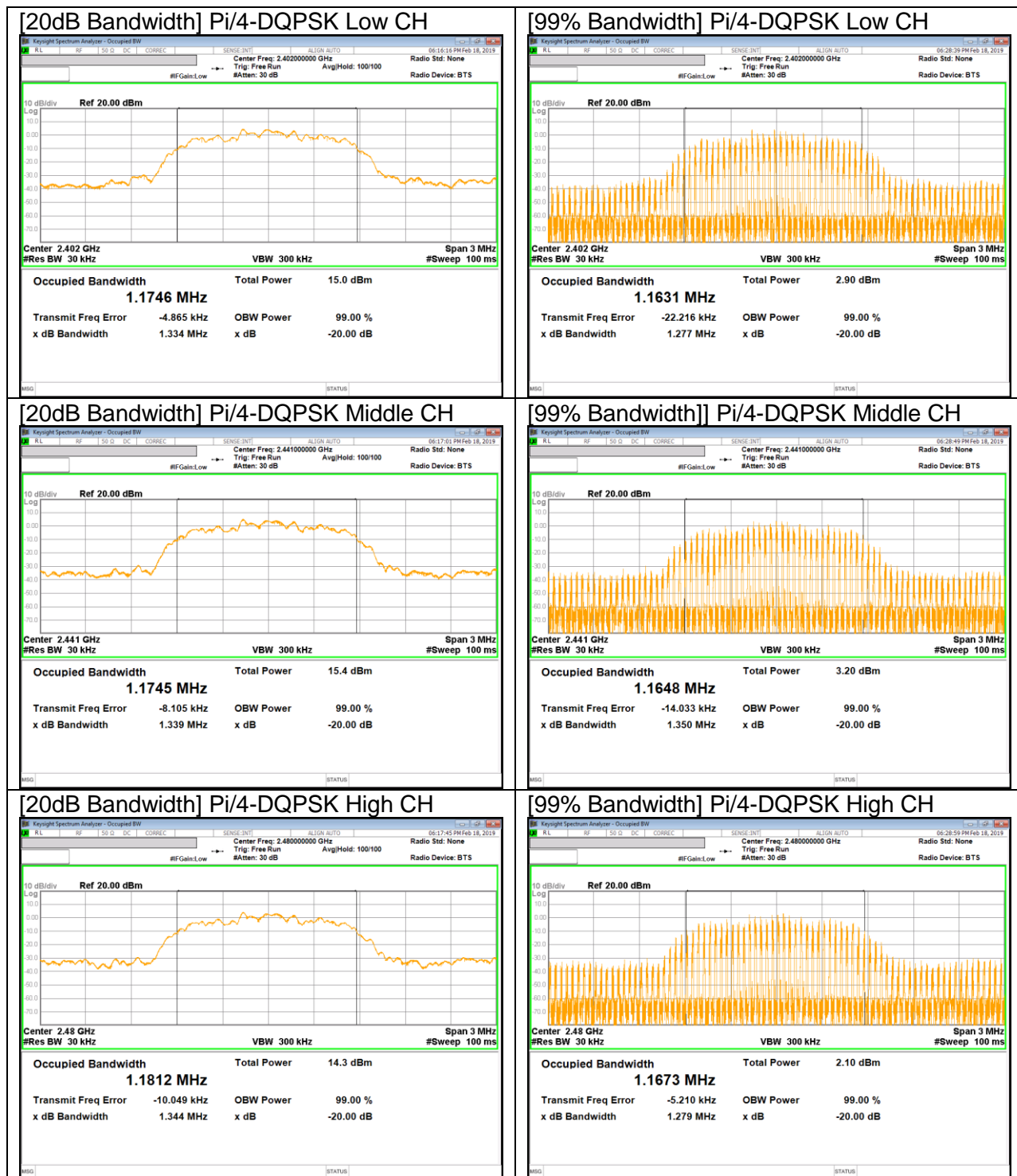

8PSK BANDWIDTH

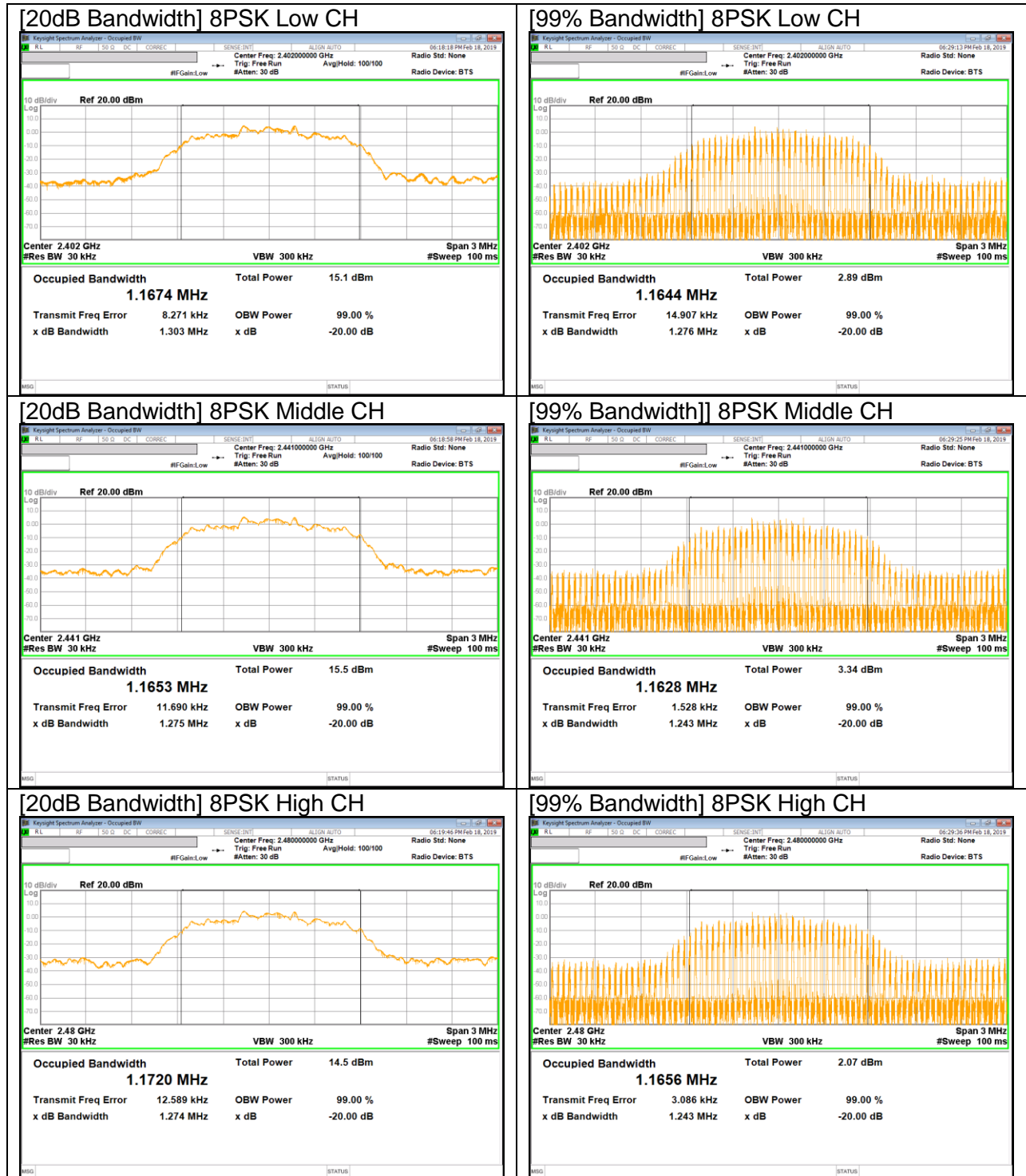

9. SUMMARY TABLE

FCC Part Section	Test Description	Test Limit	Test Condition	Test Result
2.1051, 15.247 (d)	Band Edge / Conducted Spurious Emission	-20dBc	Conducted	Pass
15.247 (b)(1)	TX conducted output power	<30dBm		Pass
15.247 (a)(1)	Hopping frequency separation	> two-thirds of the 20 dB bandwidth		Pass
15.247 (a)(1)(iii)	Number of Hopping channels	More than 15 non-overlapping channels		Pass
15.247 (a)(1)(iii)	Avg Time of Occupancy	< 0.4sec		Pass
15.207 (a)	AC Power Line conducted emissions	Section 10	Power Line conducted	Pass
15.205, 15.209	Radiated Spurious Emission	< 54dBuV/m	Radiated	Pass

10. ANTENNA PORT TEST RESULTS

10.1. HOPPING FREQUENCY SEPARATION

LIMIT

FCC §15.247 (a) (1)

Frequency hopping systems shall have hopping channel carrier frequencies separated by a minimum of 25 kHz or the 20 dB bandwidth of the hopping channel, whichever is greater.

Alternatively, frequency hopping systems operating in the 2400-2483.5 MHz band JUN have hopping channel carrier frequencies that are separated by 25 kHz or two-thirds of the 20 dB bandwidth of the hopping channel, whichever is greater, provided the systems operate with an output power no greater than 125 mW.

TEST PROCEDURE

The transmitter output is connected to a spectrum analyzer. The RBW is set to 300 kHz and the VBW is set to 300 kHz. The sweep time is coupled.

RESULTS

HOPPING FREQUENCY SEPARATION PLOT

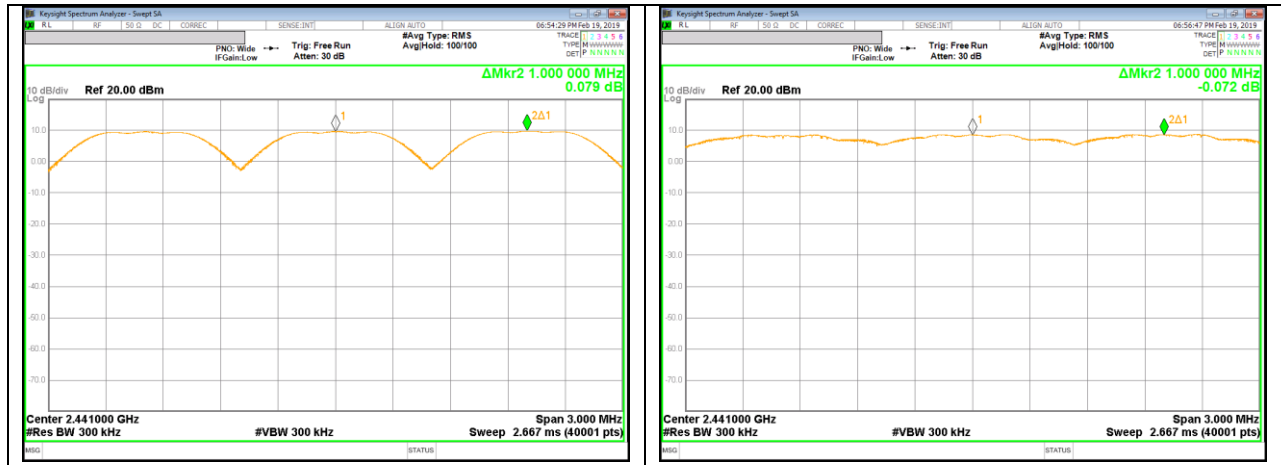

[GFSK]

[8PSK]

10.2. NUMBER OF HOPPING CHANNELS

LIMIT

FCC §15.247 (a) (1) (iii)

Frequency hopping systems in the 2400 – 2483.5 MHz band shall use at least 15 non-overlapping channels.

TEST PROCEDURE

The transmitter output is connected to a spectrum analyzer. The span is set to cover the entire authorized band, in either a single sweep or in multiple contiguous sweeps. The RBW is set to a maximum of 1 % of the span. The analyzer is set to Max Hold.

RESULTS

Normal Mode: 79 Channels observed.

NUMBER OF HOPPING CHANNELS (100 MHz SPAN)

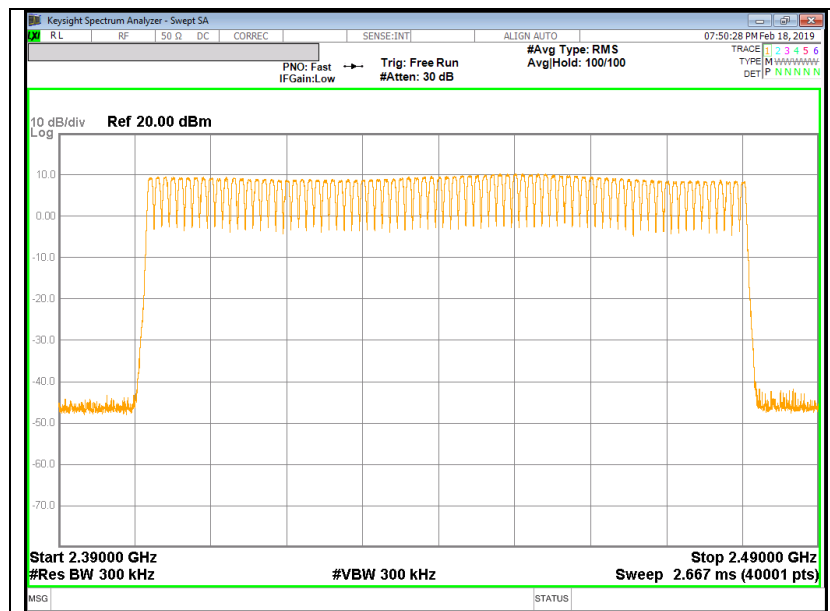

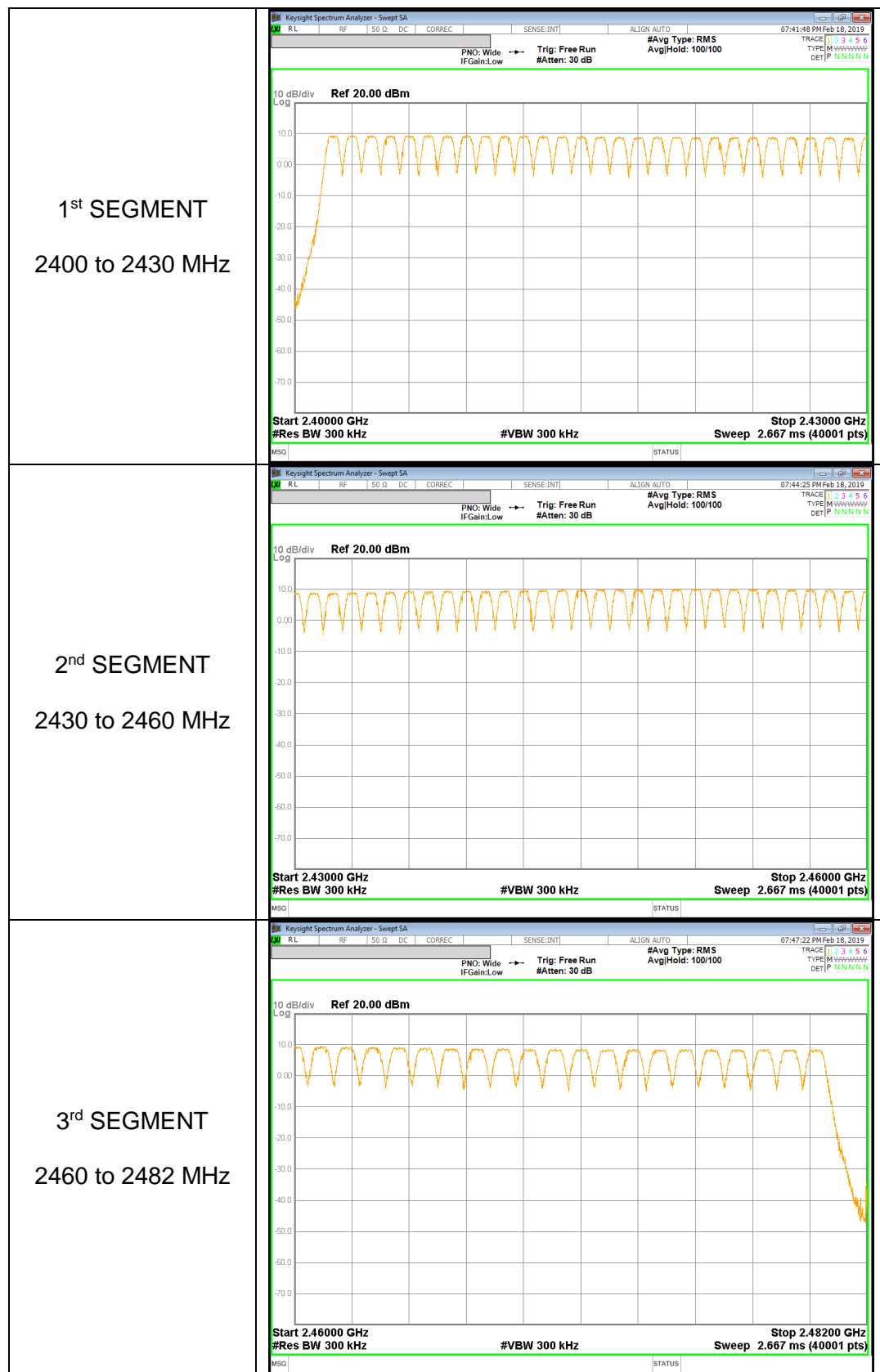

NUMBER OF HOPPING CHANNELS PLOTS[8PSK]

NUMBER OF HOPPING CHANNELS (100 MHZ SPAN)

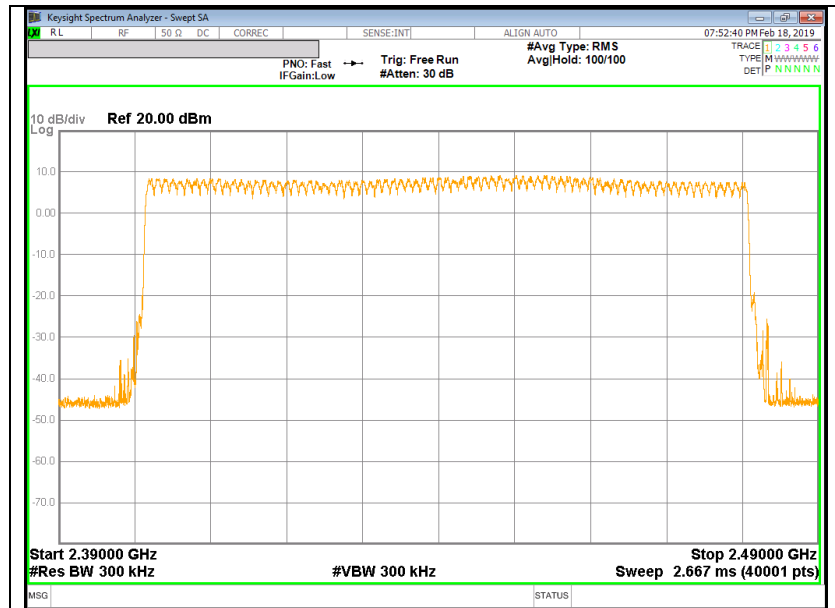

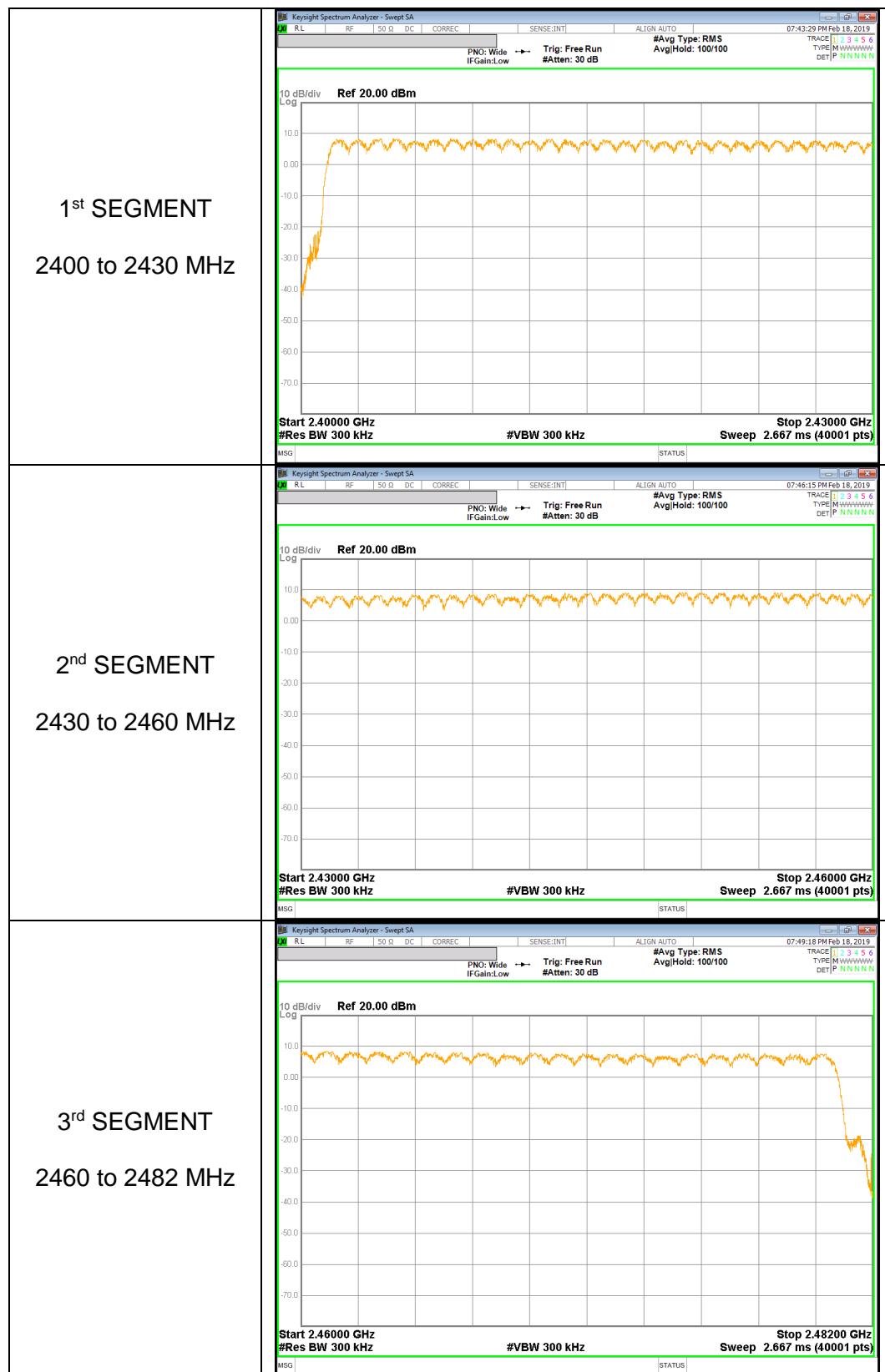

10.3. AVERAGE TIME OF OCCUPANCY

LIMIT

FCC §15.247 (a) (1) (iii)

The average time of occupancy on any channel shall not be greater than 0.4 seconds within a period of 0.4 seconds multiplied by the number of hopping channels employed.

TEST PROCEDURE

The transmitter output is connected to a spectrum analyzer. The span is set to 0 Hz, centered on a single, selected hopping channel. The width of a single pulse is measured in a fast scan. The number of pulses is measured in a 3.16 second scan, to enable resolution of each occurrence.

The average time of occupancy in the specified 31.6 second period (79 channels * 0.4 s) is equal to 10 * (# of pulses in 3.16 s) * pulse width.

For AFH mode, the average time of occupancy in the specified 8 second period (20 channels * 0.4 seconds) is equal to 10 * (# of pulses in 0.8 s) * pulse width.

RESULTS[GFSK]

DH Packet	Pulse Width [msec]	Number of Pulses in 3.16 seconds	Average Time of Occupancy [sec]	Limit [sec]	Margin [sec]
GFSK Normal					
DH1	0.374	32	0.119648	0.4	-0.2804
DH3	1.630	16	0.260800	0.4	-0.1392
DH5	2.877	12	0.345240	0.4	-0.0548
GFSK AFH					
DH Packet	Pulse Width [msec]	Number of Pulses in 0.8 seconds	Average Time of Occupancy [sec]	Limit [sec]	Margin [sec]
DH1	0.374	8	0.029912	0.4	-0.3701
DH3	1.630	4	0.065200	0.4	-0.3348
DH5	2.877	3	0.086310	0.4	-0.3137

DH1

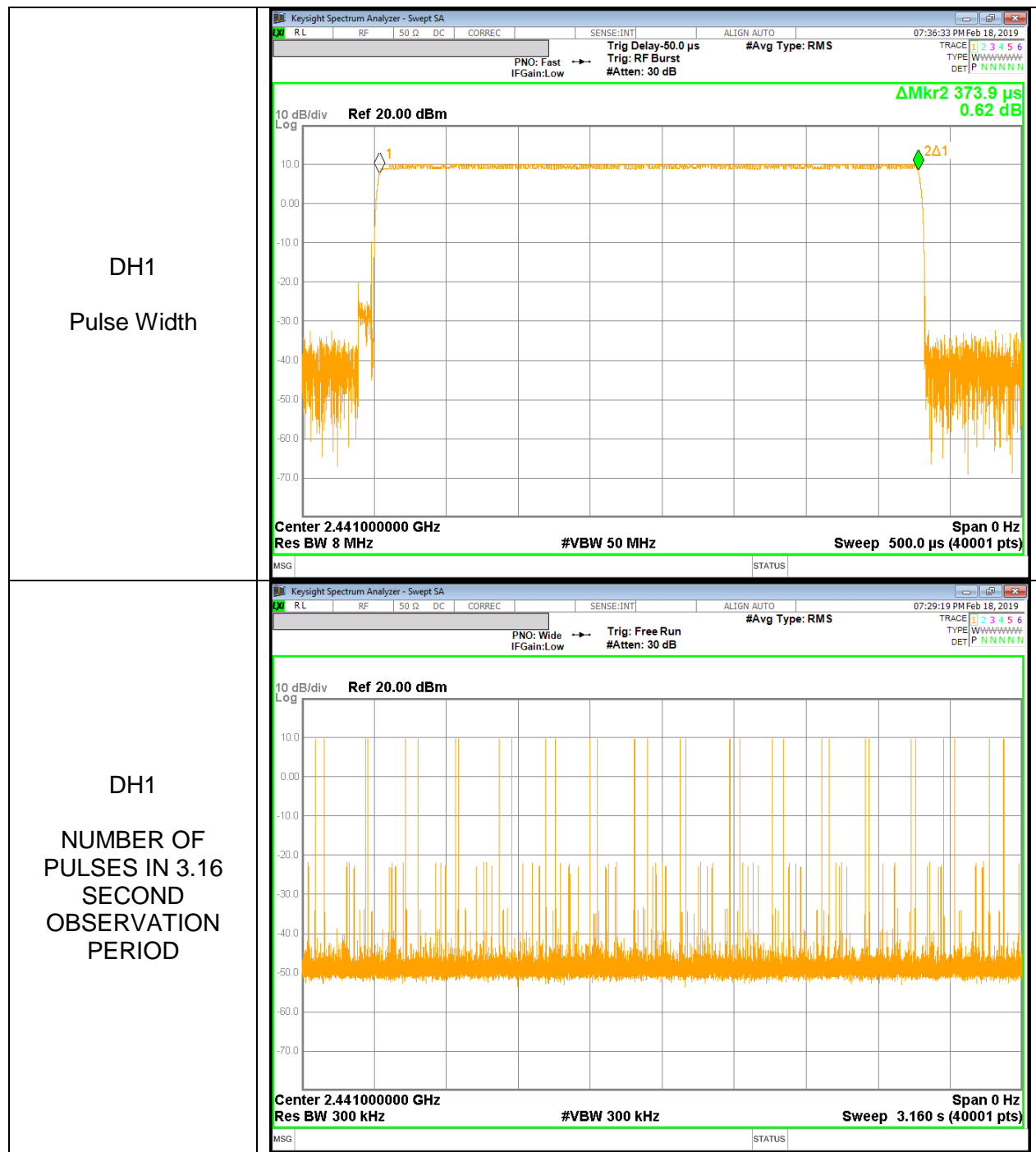

DH3

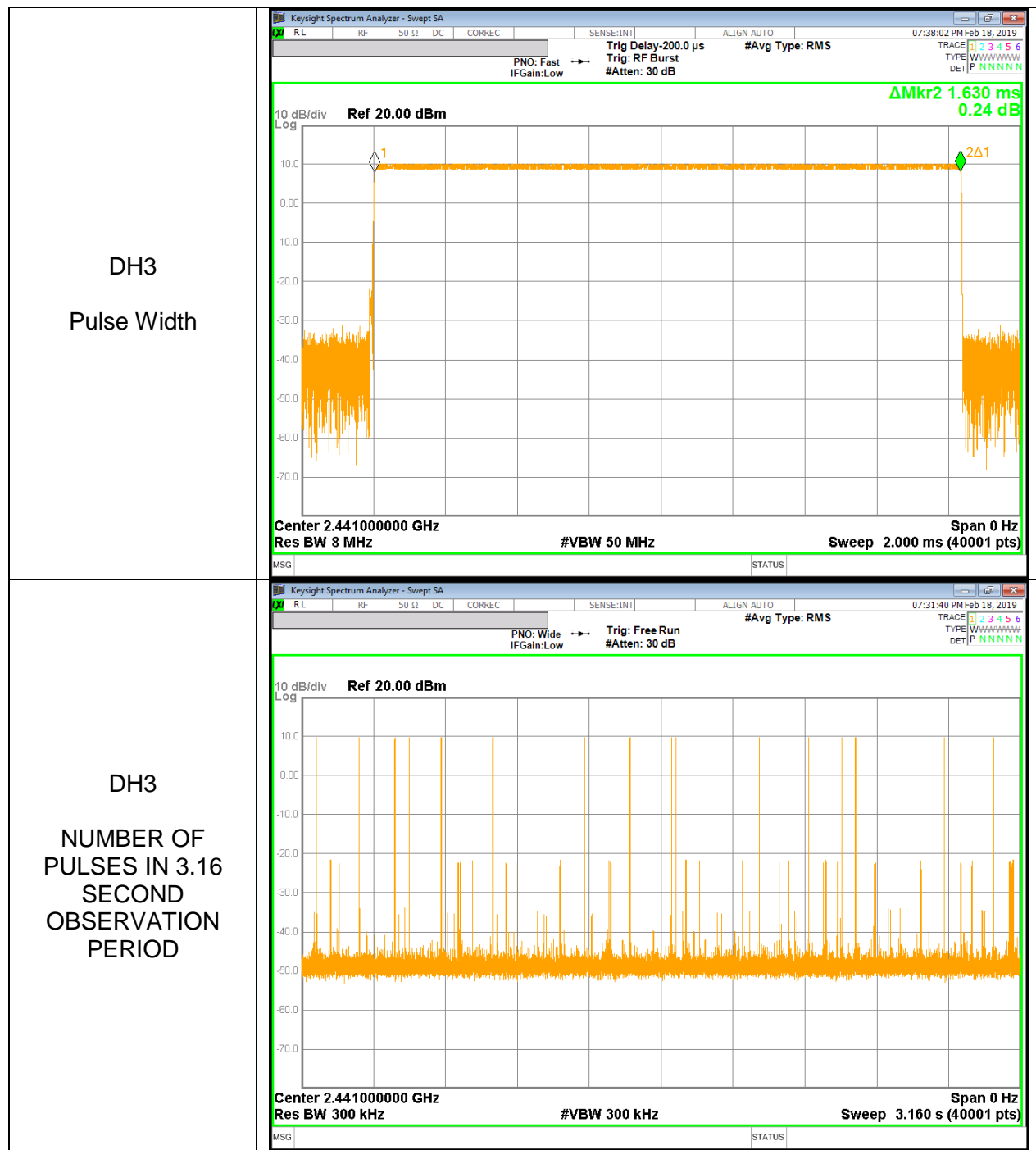

DH5

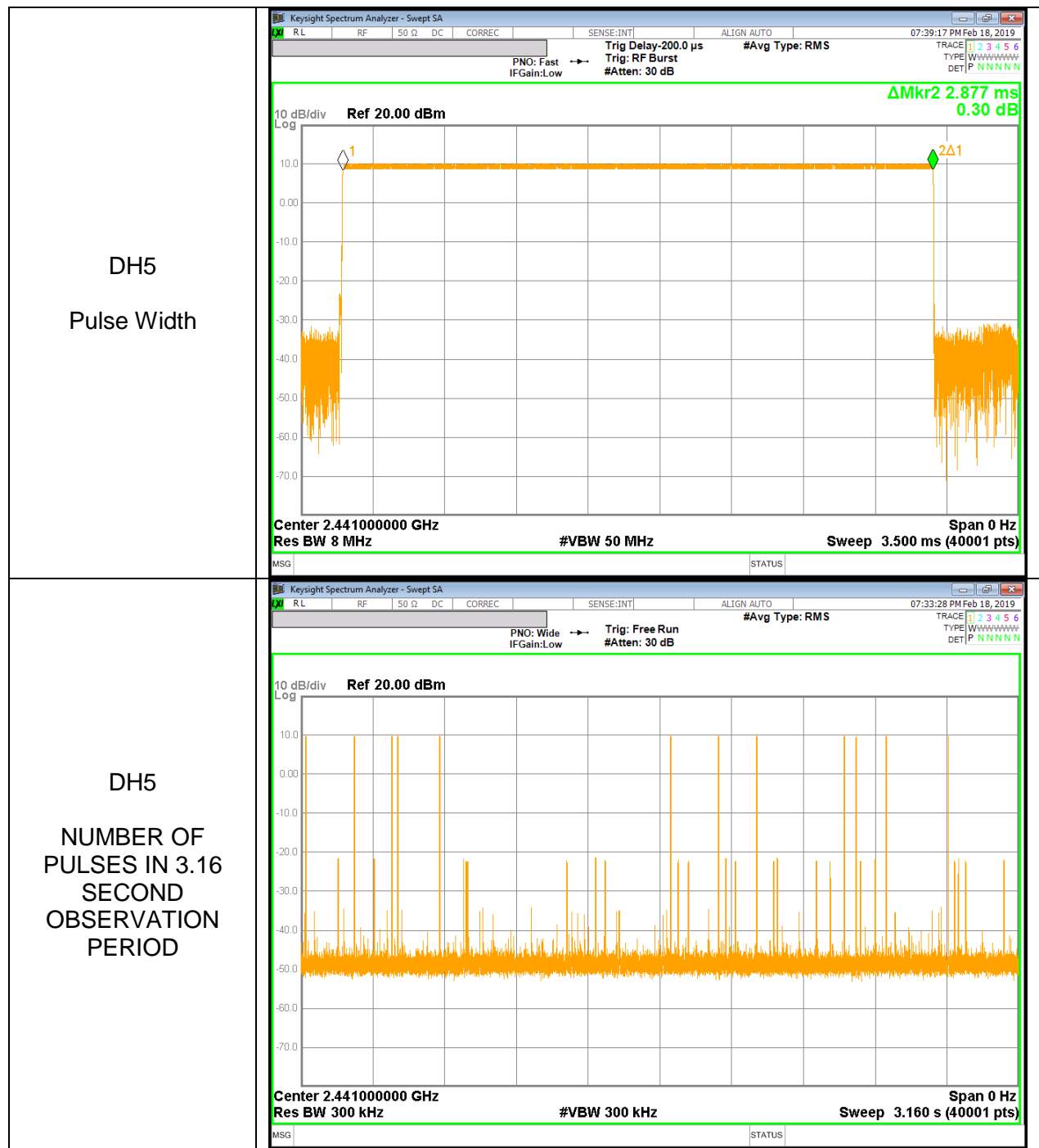

RESULTS[8PSK]

DH Packet	Pulse Width [msec]	Number of Pulses in 3.16 seconds	Average Time of Occupancy [sec]	Limit [sec]	Margin [sec]
GFSK Normal					
DH1	0.386	32	0.123552	0.4	-0.2764
DH3	1.634	16	0.261440	0.4	-0.1386
DH5	2.885	12	0.346200	0.4	-0.0538
GFSK AFH					
DH Packet	Pulse Width [msec]	Number of Pulses in 0.8 seconds	Average Time of Occupancy [sec]	Limit [sec]	Margin [sec]
GFSK AFH					
DH1	0.386	8	0.030888	0.4	-0.3691
DH3	1.634	4	0.065360	0.4	-0.3346
DH5	2.885	3	0.086550	0.4	-0.3135

DH1

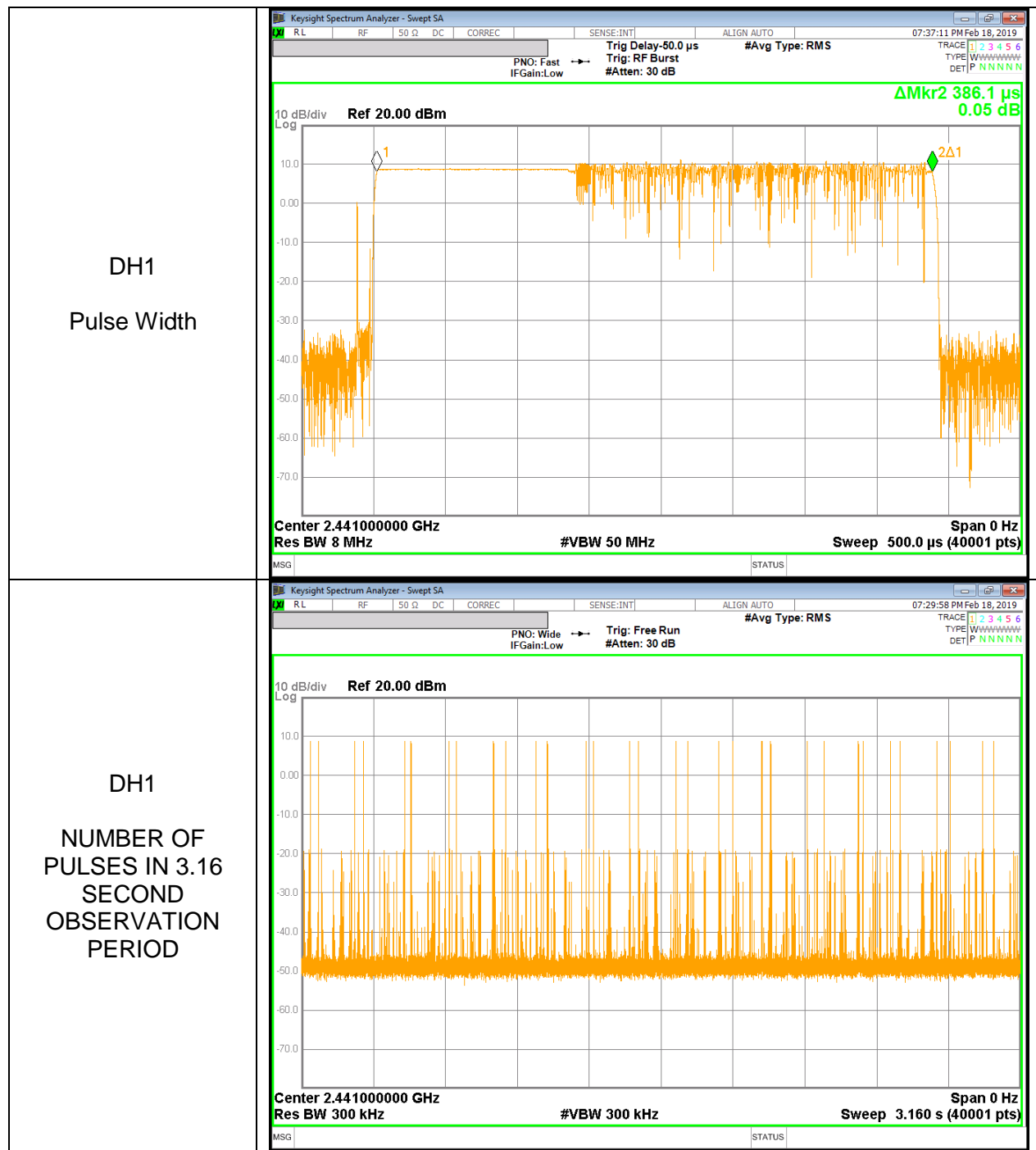

DH3

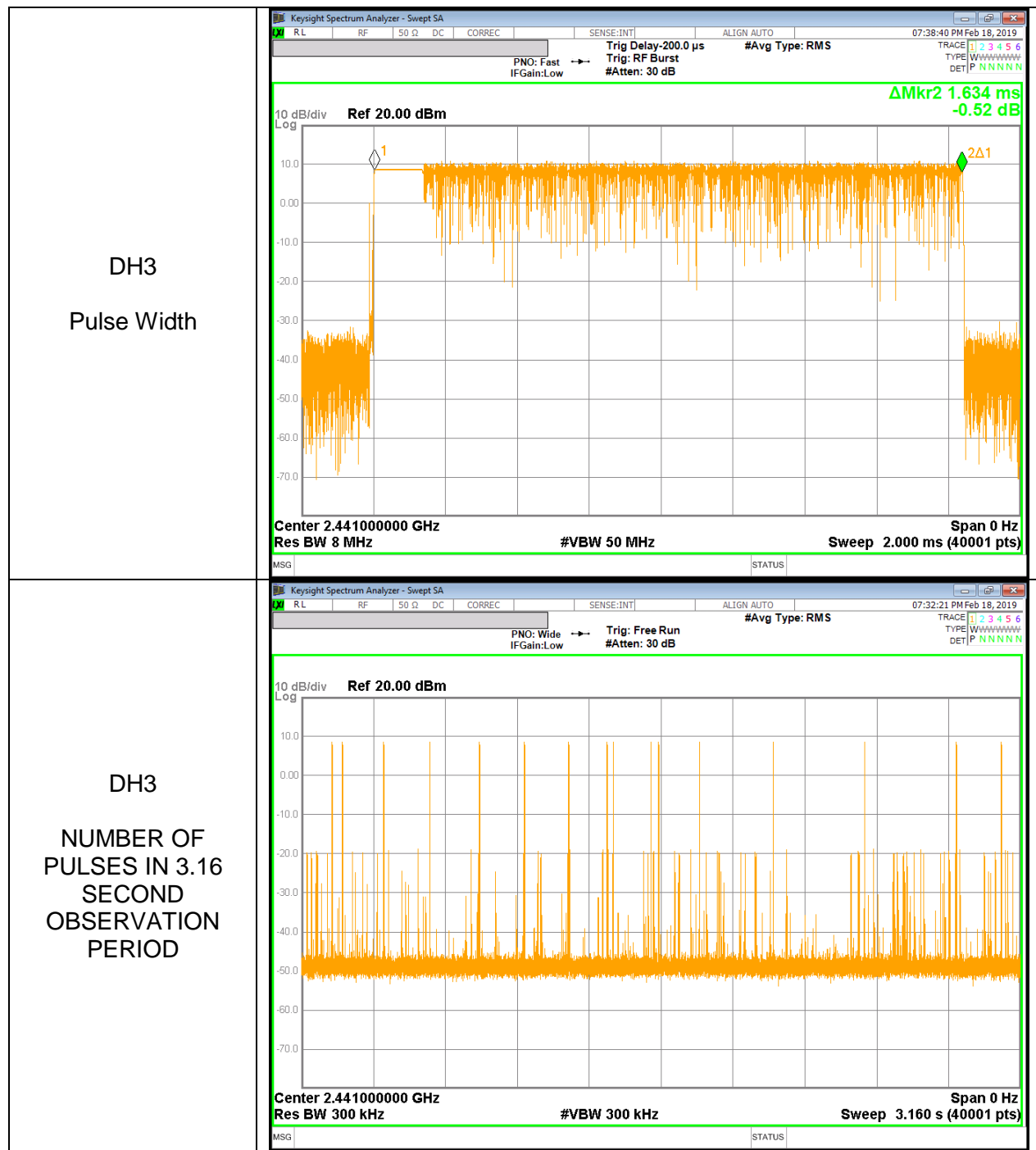

DH5

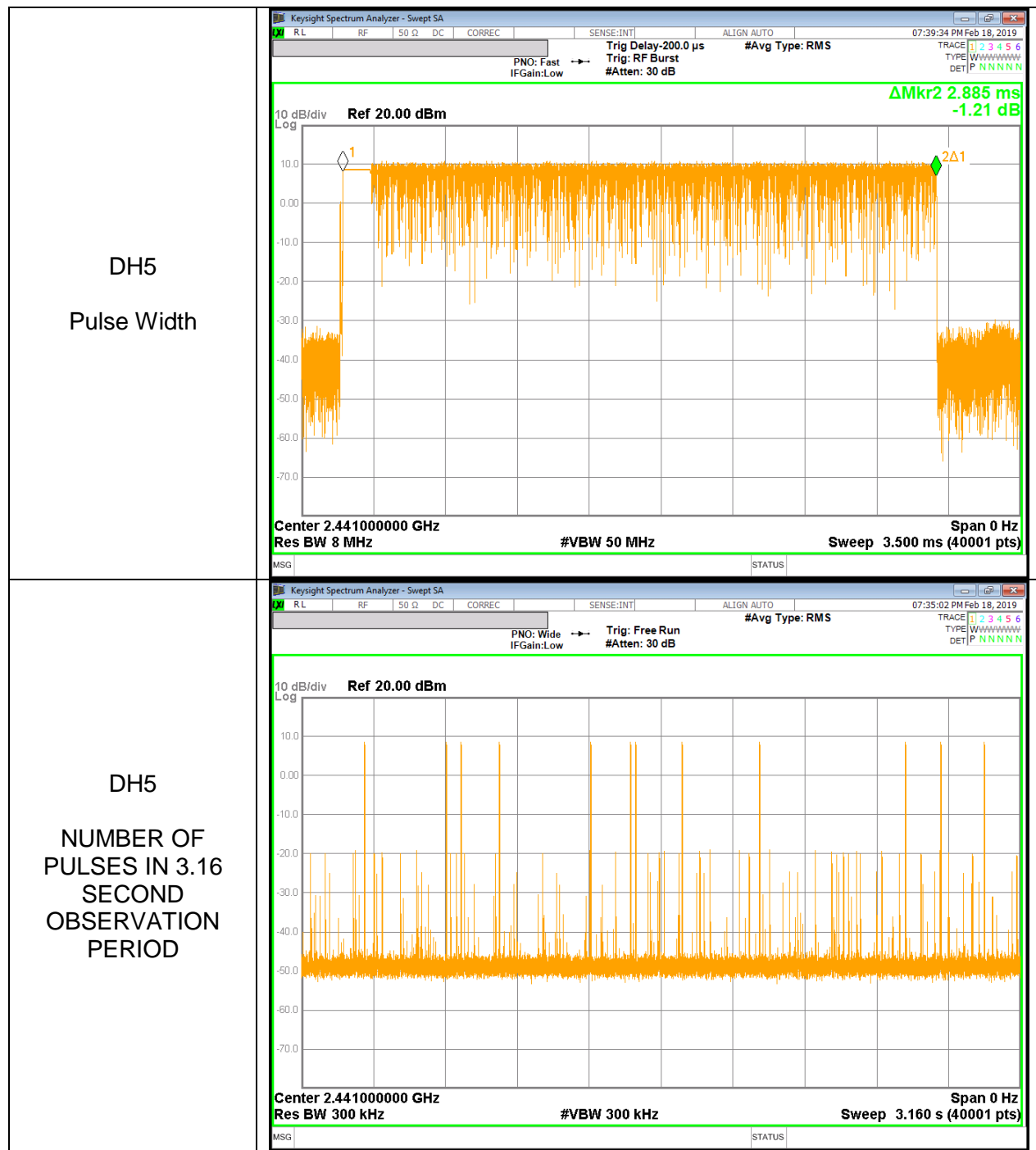

10.4. OUTPUT POWER

LIMIT

§15.247 (b) (1)

The maximum antenna gain is less than 6 dBi, therefore the limit is 21 dBm.

TEST PROCEDURE

The transmitter output is connected to a spectrum analyzer the analyzer bandwidth is set to a value greater than the 20 dB bandwidth of the EUT.

RESULTS

10.4.1. BASIC DATA RATE GFSK MODULATION

Channel	Frequency [MHz]	Output Power [dBm]	Limit [dBm]	Margin [dB]
Low	2402	9.433	21	-11.567
Middle	2441	9.620	21	-11.38
High	2480	8.543	21	-12.457
Worst		9.620	21	-11.38

10.4.2. ENHANCED DATA RATE Pi/4-DPSK MODULATION

Channel	Frequency [MHz]	Output Power [dBm]	Limit [dBm]	Margin [dB]
Low	2402	9.715	21	-11.285
Middle	2441	9.870	21	-11.130
High	2480	8.723	21	-12.277
Worst		9.870	21	-11.130

10.4.3. ENHANCED DATA RATE 8PSK MODULATION

Channel	Frequency [MHz]	Output Power [dBm]	Limit [dBm]	Margin [dB]
Low	2402	10.647	21	-10.353
Middle	2441	10.843	21	-10.157
High	2480	9.670	21	-11.330
Worst		10.843	21	-10.157

10.4.4. OUTPUT POWER PLOTS

GFSK OUTPUT POWER

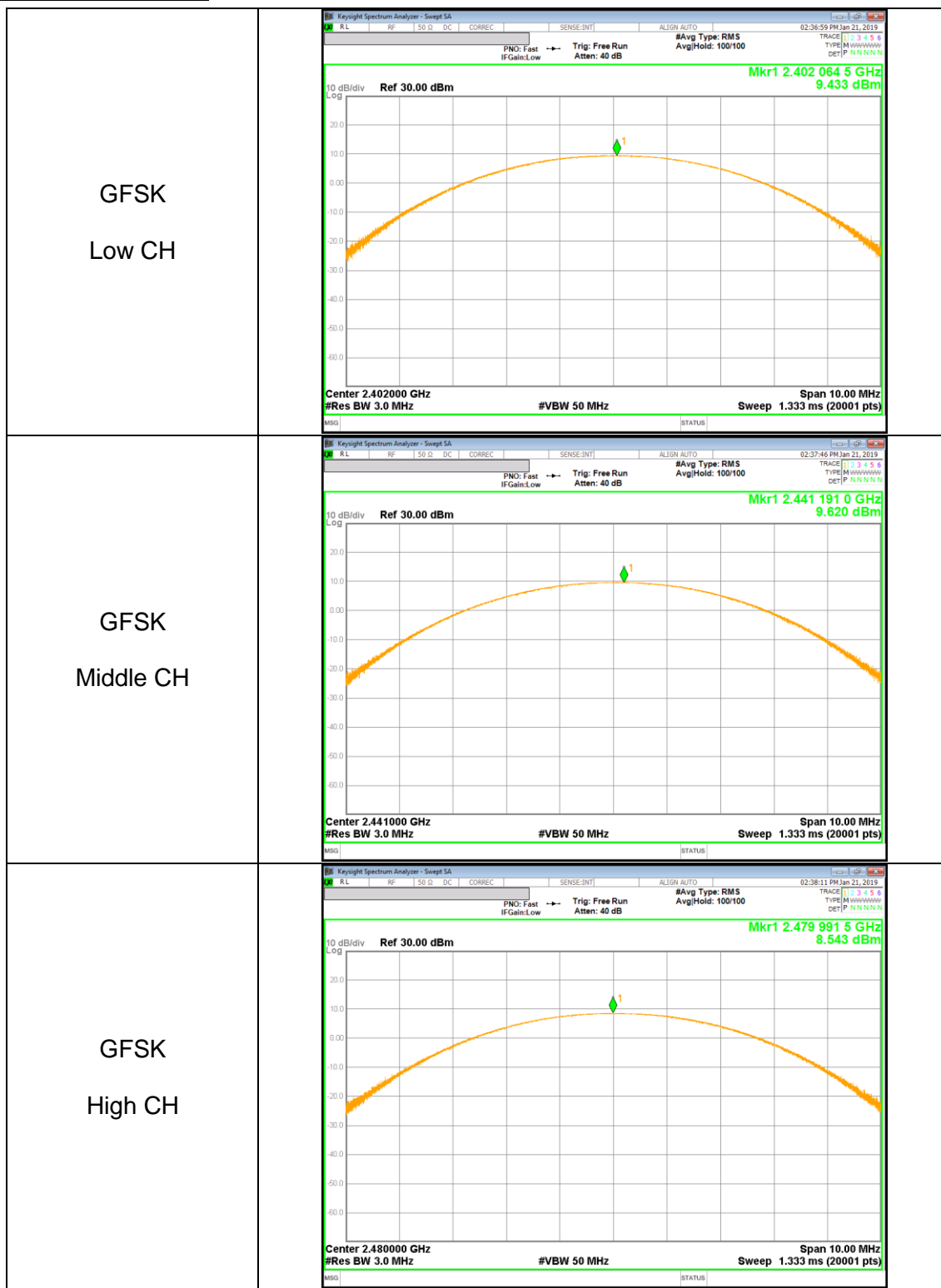

Pi/4-DPSK OUTPUT POWER

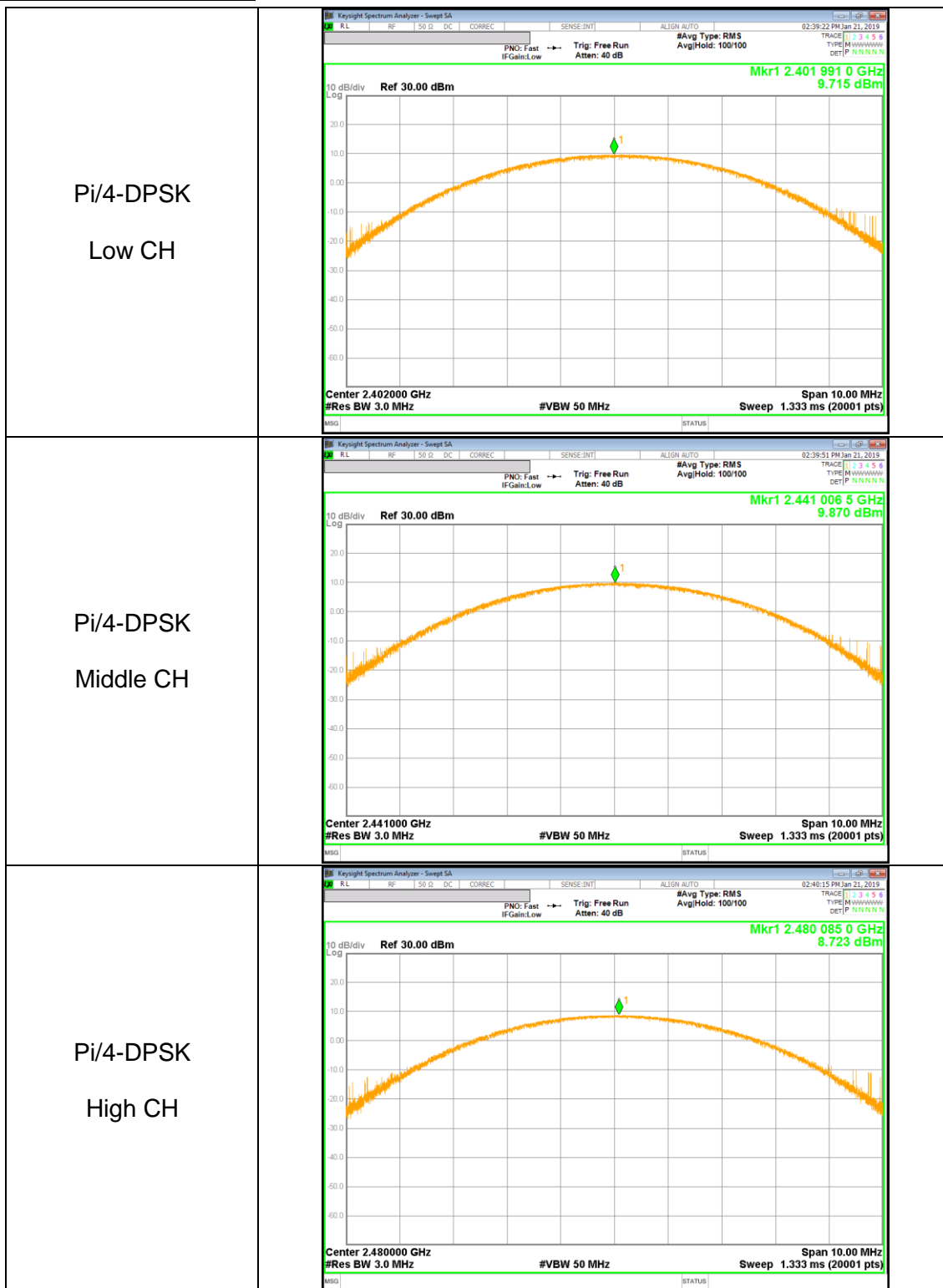

8PSK OUTPUT POWER

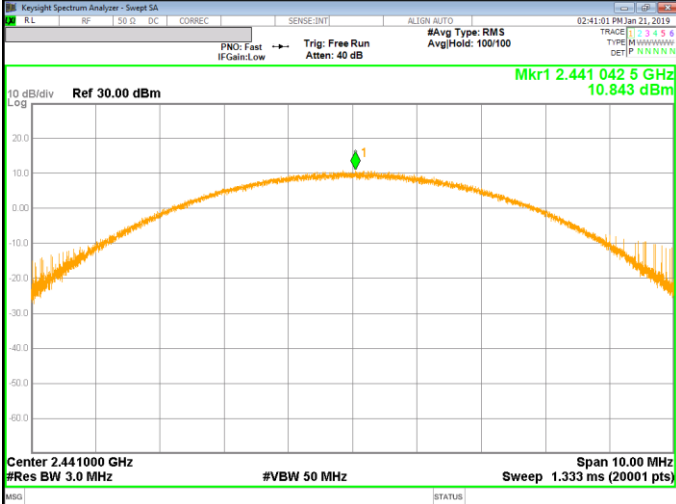
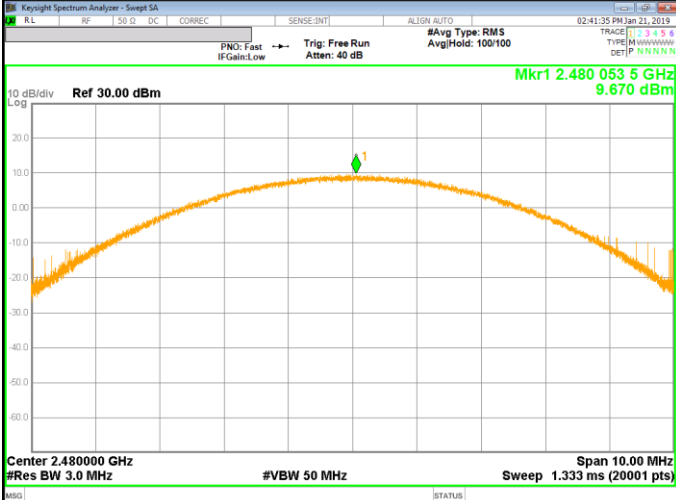
<p>8PSK Low CH</p>	 <p>KeySight Spectrum Analyzer - Swept SA Ref 30.00 dBm Mkr1 2.401 972 5 GHz 10.647 dBm Center 2.402000 GHz #Res BW 3.0 MHz #VBW 50 MHz Span 10.00 MHz Sweep 1.333 ms (20001 pts)</p>
<p>8PSK Middle CH</p>	 <p>KeySight Spectrum Analyzer - Swept SA Ref 30.00 dBm Mkr1 2.441 042 5 GHz 10.843 dBm Center 2.441000 GHz #Res BW 3.0 MHz #VBW 50 MHz Span 10.00 MHz Sweep 1.333 ms (20001 pts)</p>
<p>8PSK High CH</p>	 <p>KeySight Spectrum Analyzer - Swept SA Ref 30.00 dBm Mkr1 2.480 053 5 GHz 9.670 dBm Center 2.480000 GHz #Res BW 3.0 MHz #VBW 50 MHz Span 10.00 MHz Sweep 1.333 ms (20001 pts)</p>

10.5. AVERAGE POWER

LIMIT

None; for reporting purposes only.

TEST PROCEDURE

The transmitter output is connected to a power meter.

RESULTS

The cable assembly insertion loss was entered as an offset in the power meter to allow for direct reading of power.

10.5.1. BASIC DATA RATE GFSK MODULATION

Channel	Frequency [MHz]	AV power [dBm]	AV power [mW]
Low	2402	8.638	7.31
Middle	2441	8.851	7.67
High	2480	7.778	6.00

10.5.2. ENHANCED DATA RATE PI/4-DQPSK MODULATION

Channel	Frequency [MHz]	AV power [dBm]	AV power [mW]
Low	2402	7.057	5.08
Middle	2441	7.336	5.42
High	2480	6.362	4.33

10.5.3. ENHANCED DATA RATE 8PSK MODULATION

Channel	Frequency [MHz]	AV power [dBm]	AV power [mW]
Low	2402	7.090	5.12
Middle	2441	7.363	5.45
High	2480	6.427	4.39

10.6. CONDUCTED SPURIOUS EMISSIONS

LIMITS

FCC §15.247 (d)

Limit = -20 dBc

TEST PROCEDURE

The transmitter output is connected to a spectrum analyzer. The resolution bandwidth is set to 100 kHz. The video bandwidth is set to 300 kHz.

The spectrum from 30 MHz to 26 GHz is investigated with the transmitter set to the lowest, middle, and highest channels.

The bandedges at 2.4 and 2.4835 GHz are investigated with the transmitter set to the normal hopping mode.

RESULTS

10.6.1. BASIC DATA RATE GFSK MODULATION

GFSK Mode

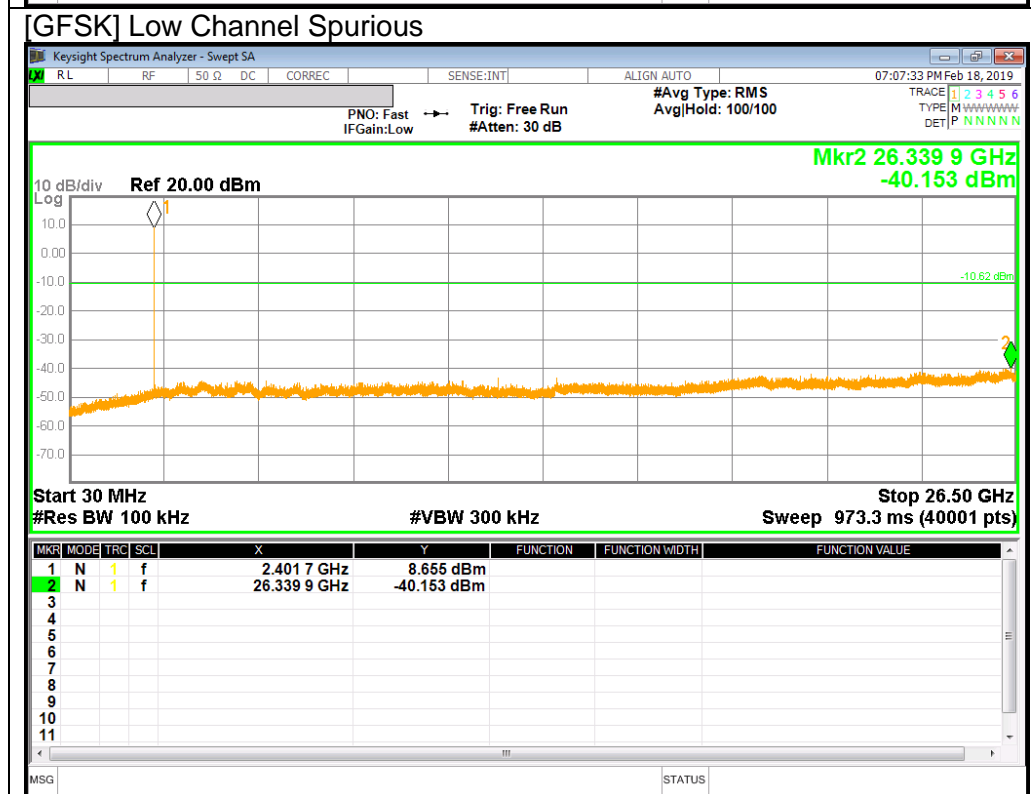
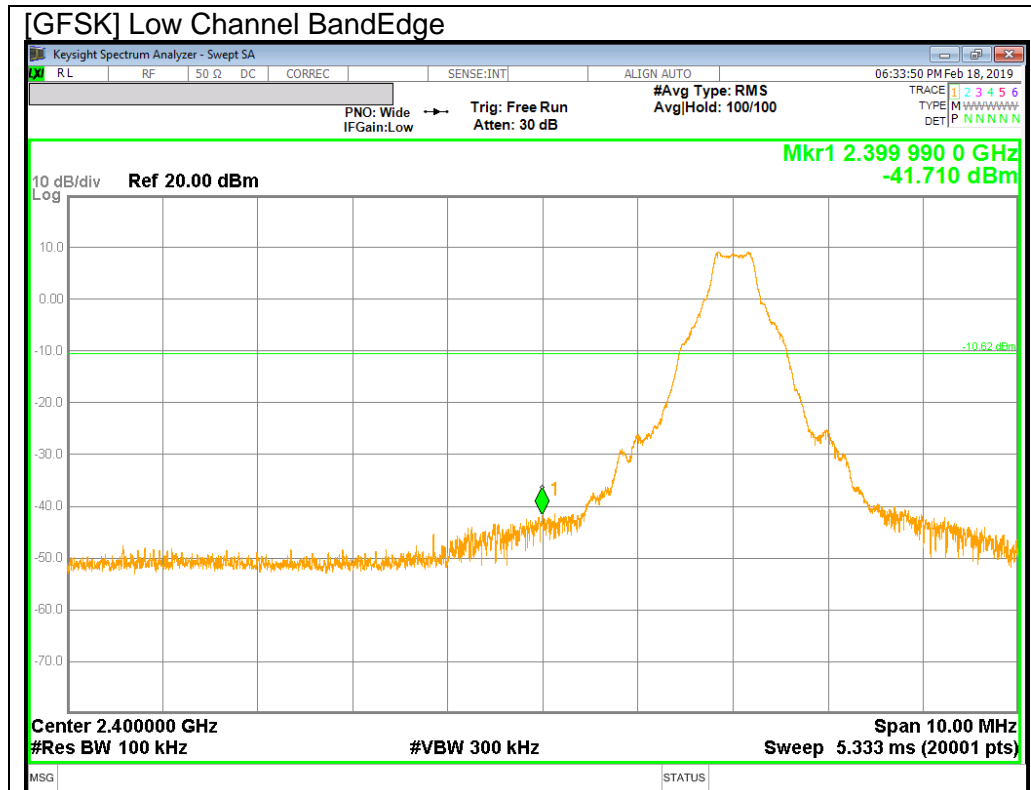

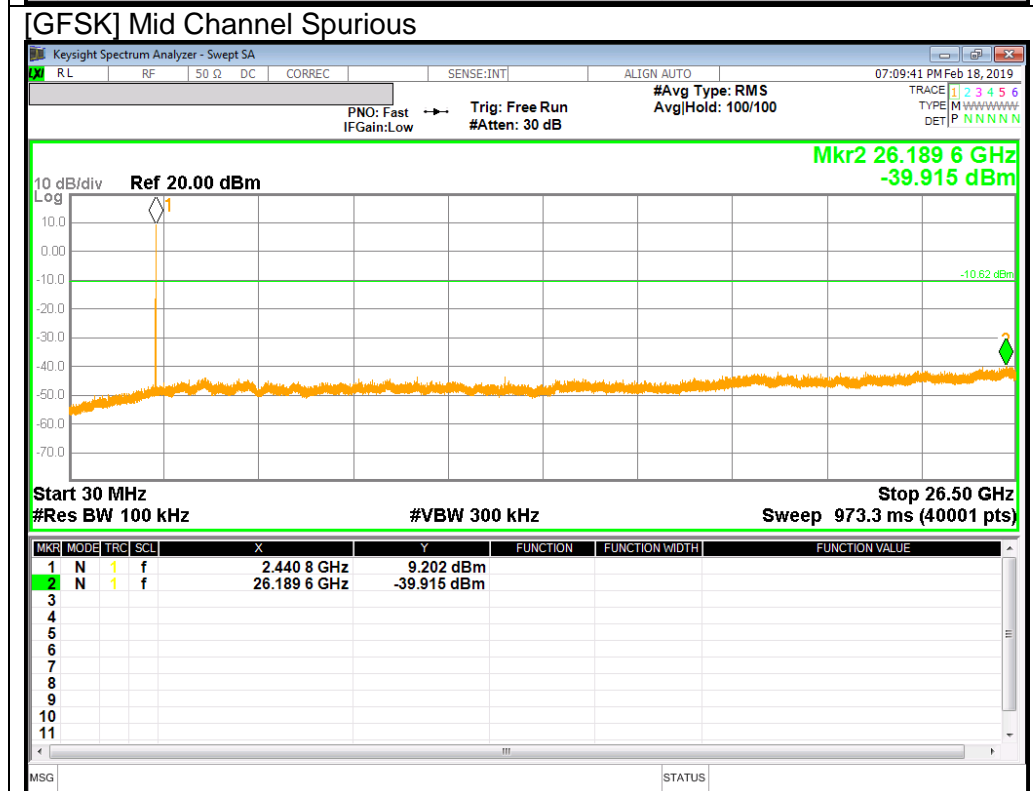
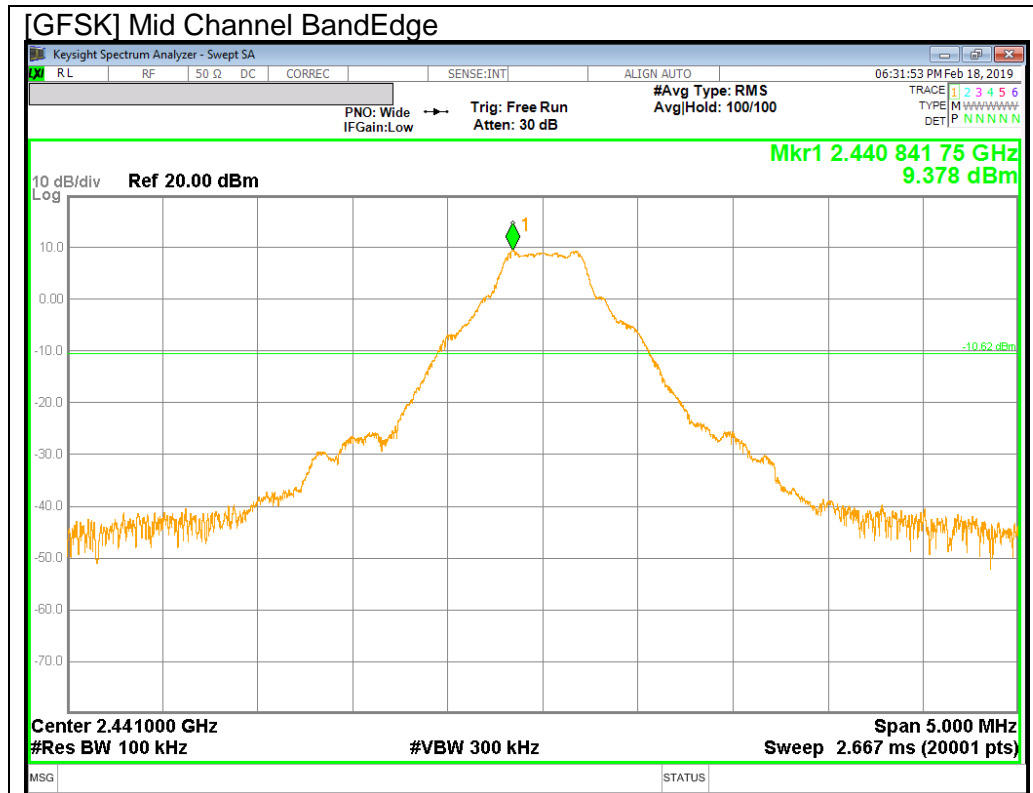

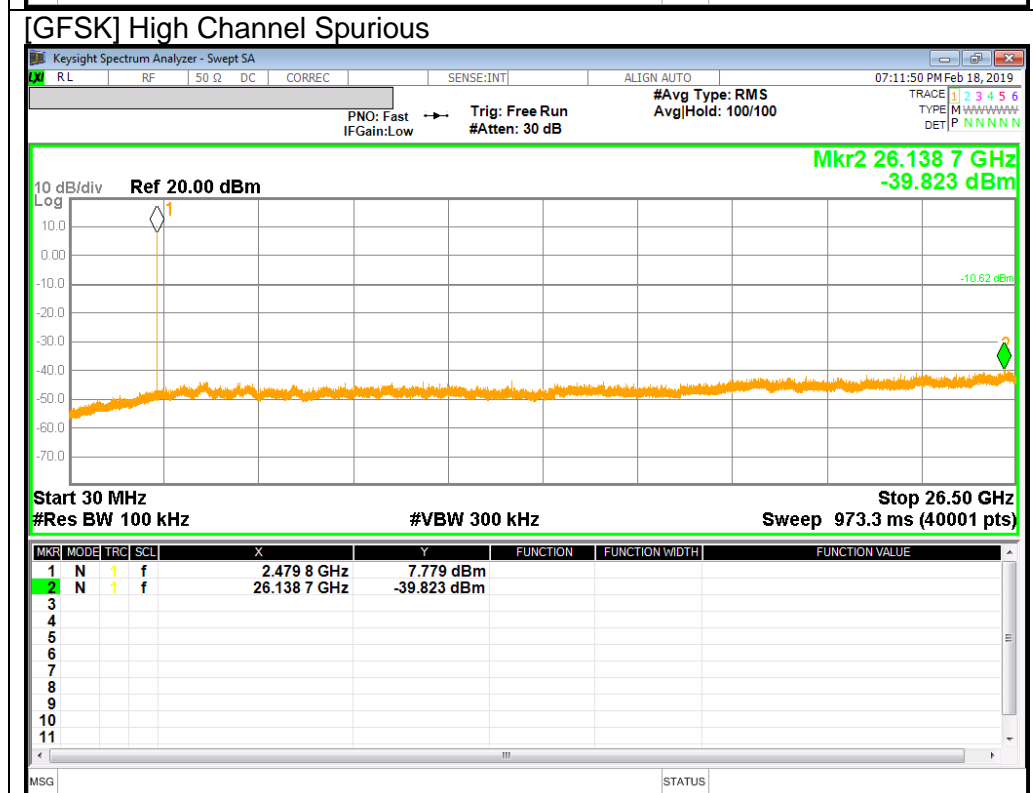
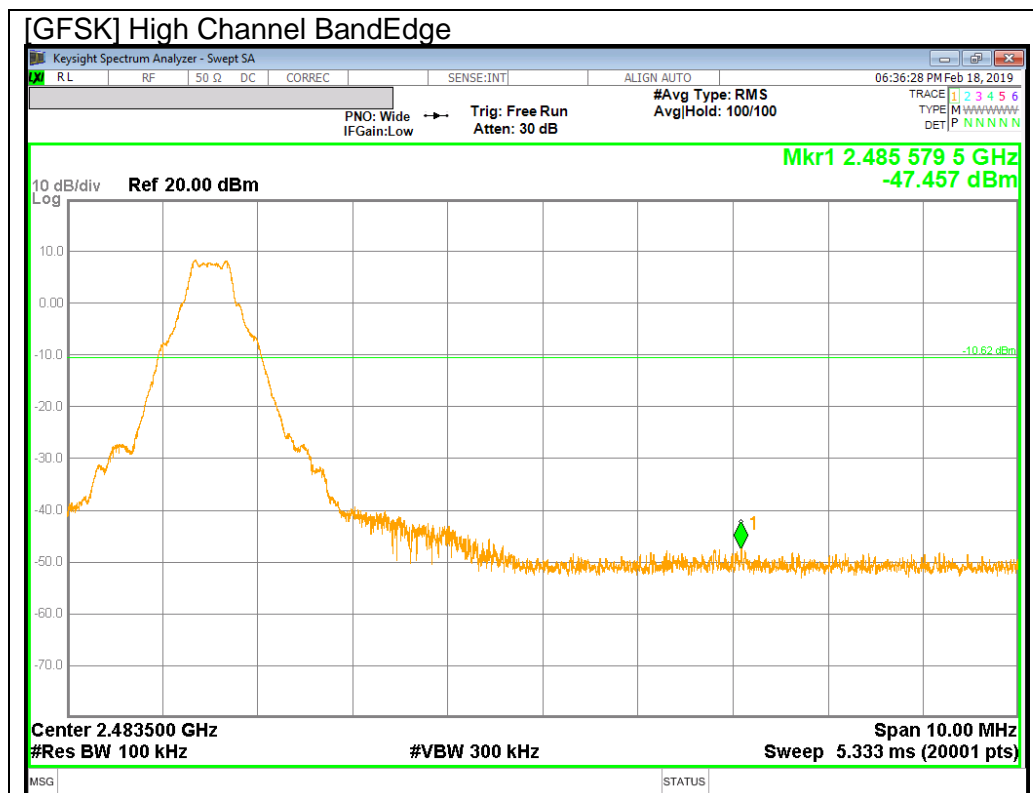

BandEdge Emission at GFSK Hopping Mode

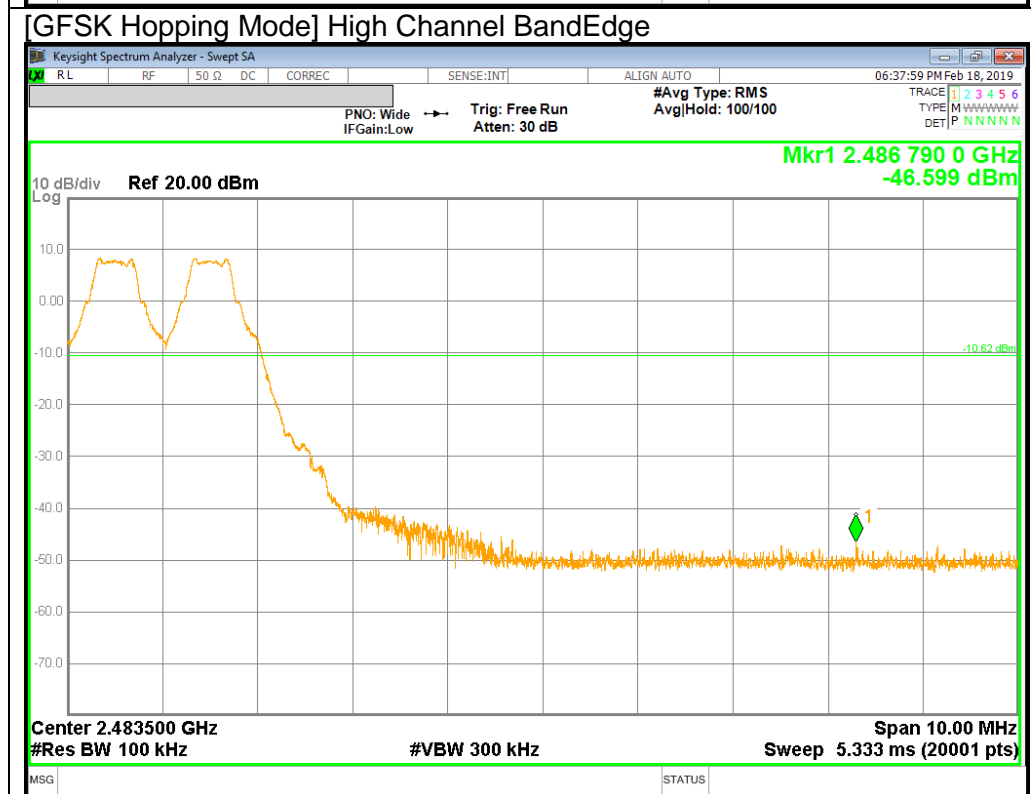
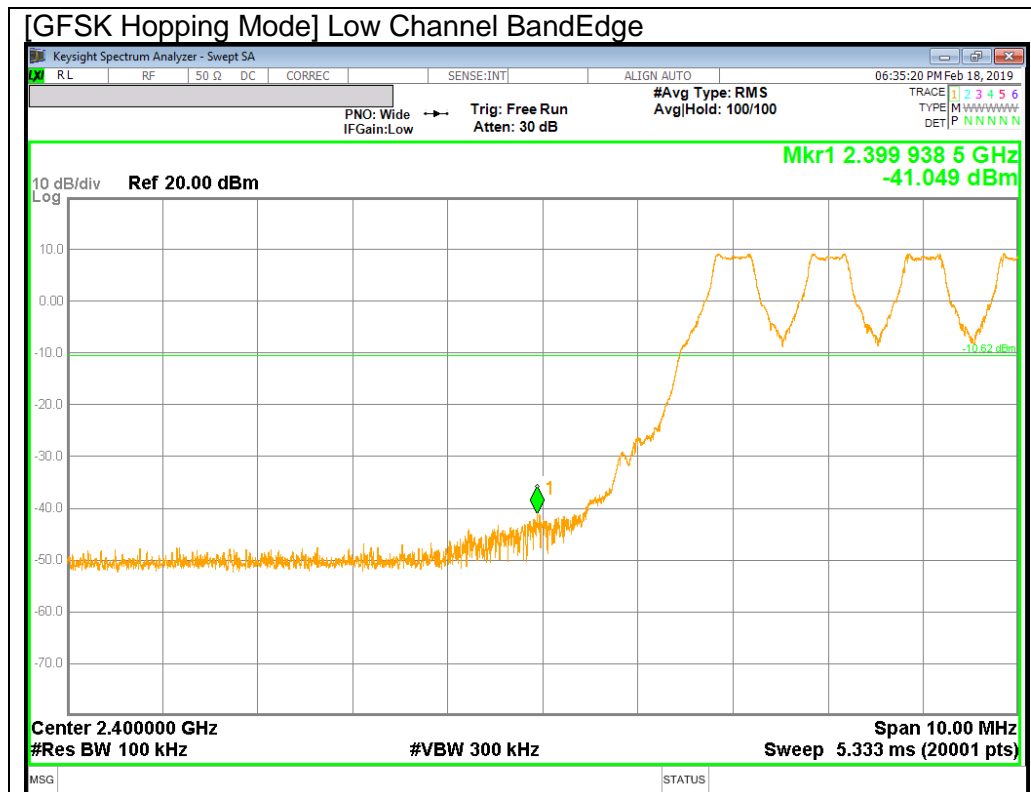

10.6.2. ENHANCED DATA RATE PI/4-DQPSK MODULATION

PI/4-DQPSK Mode

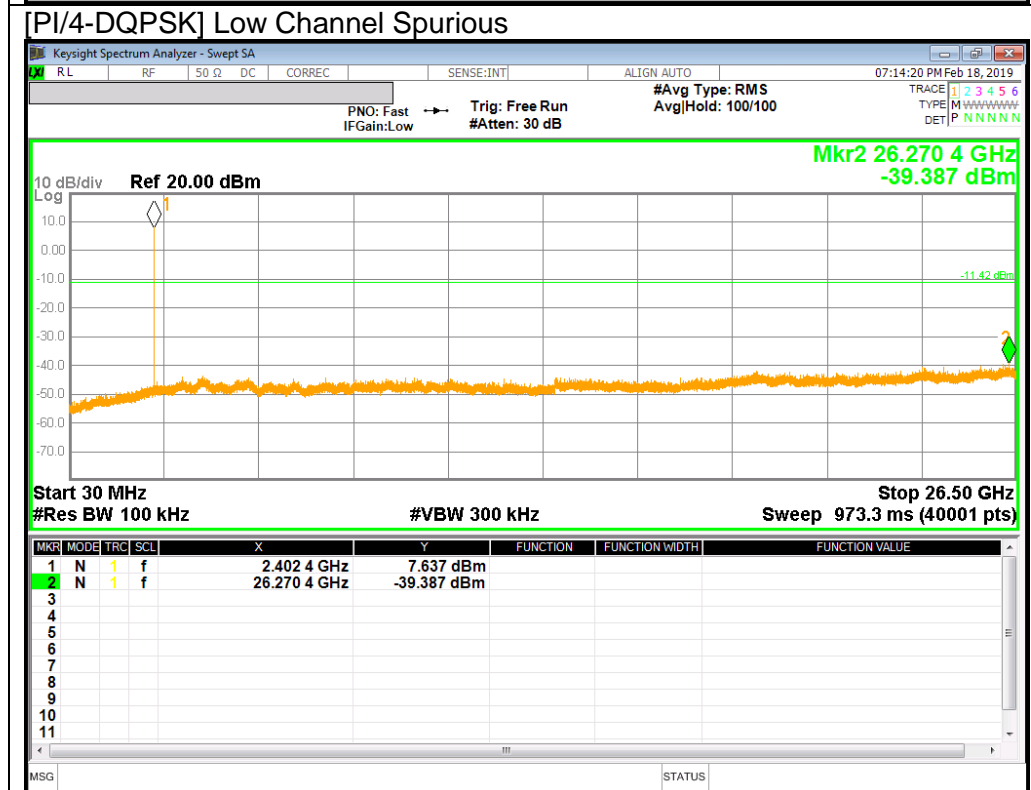
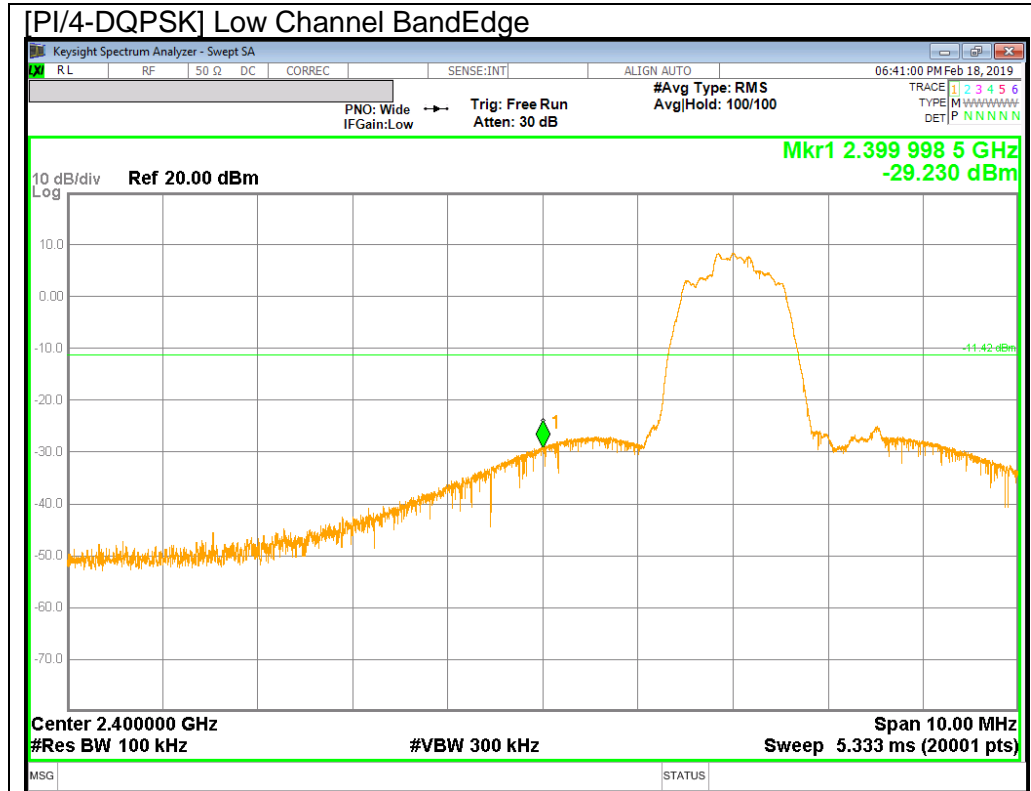

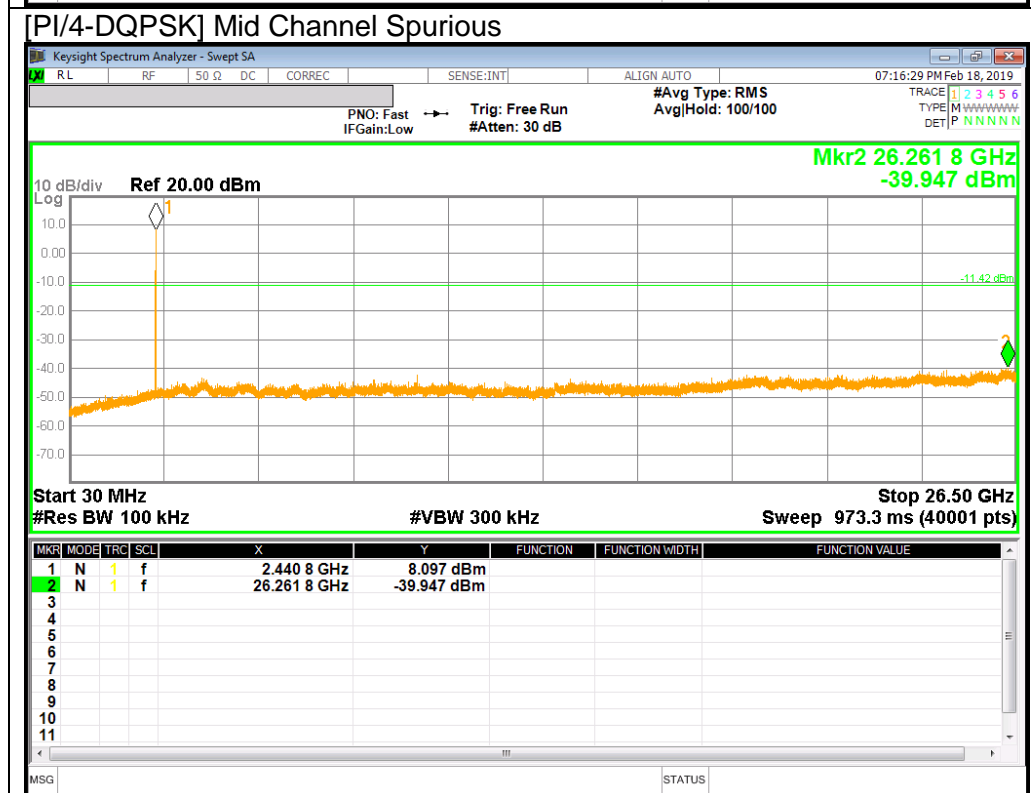
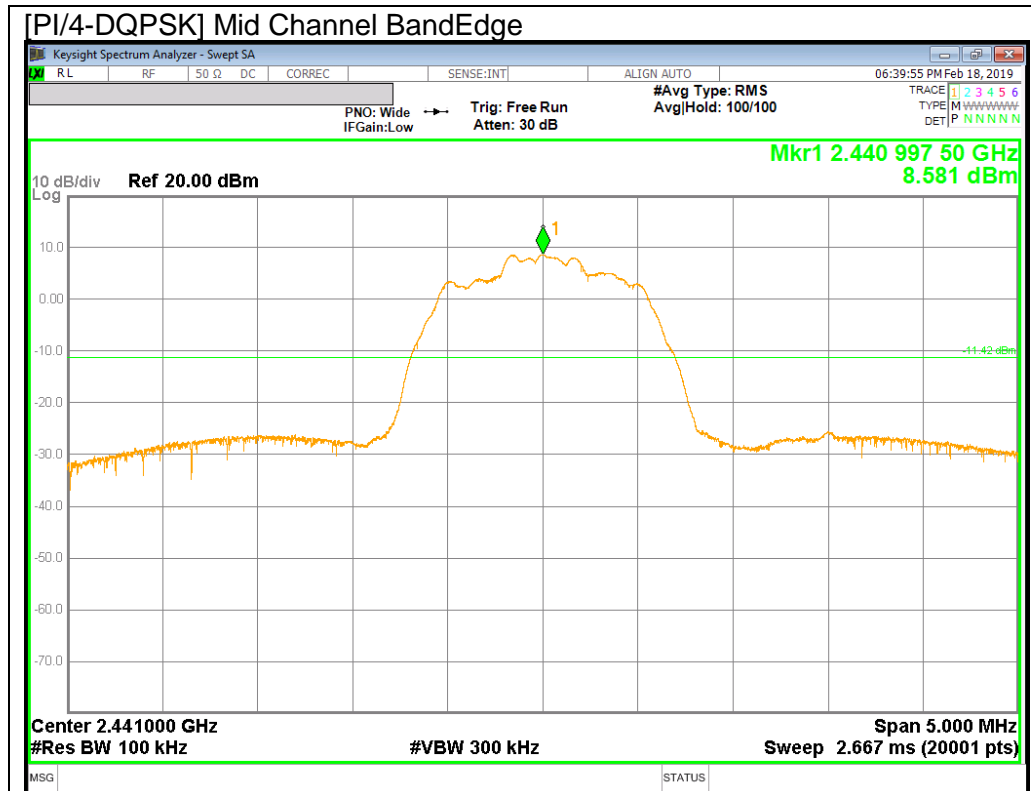

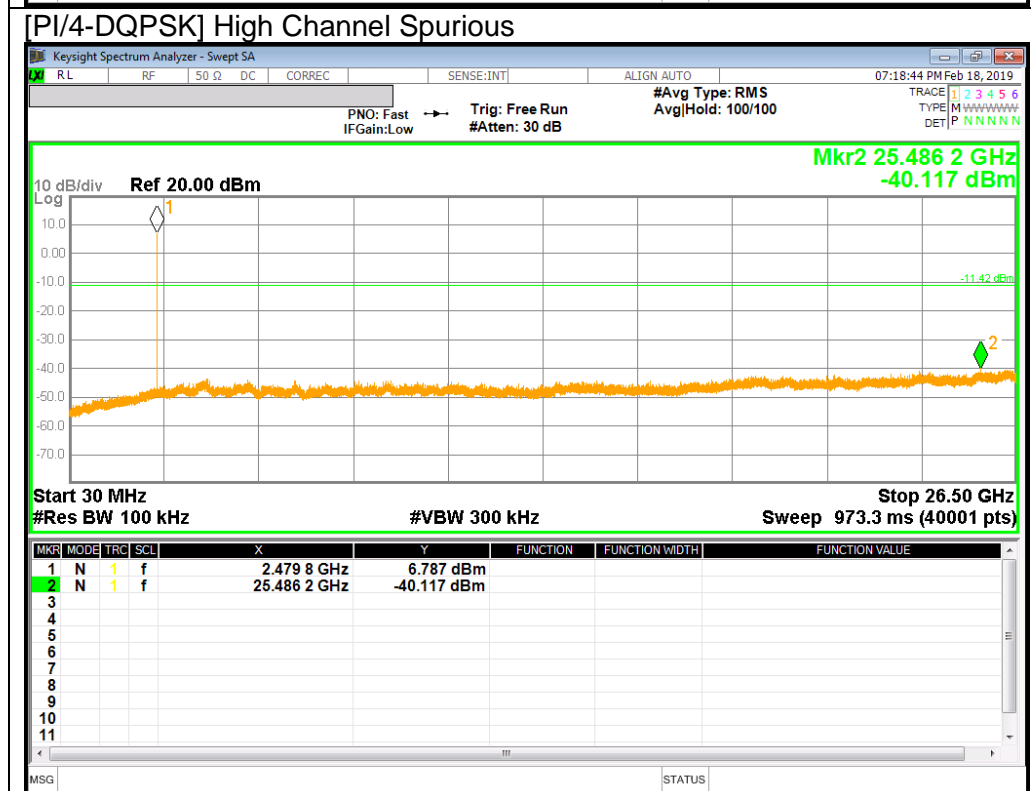
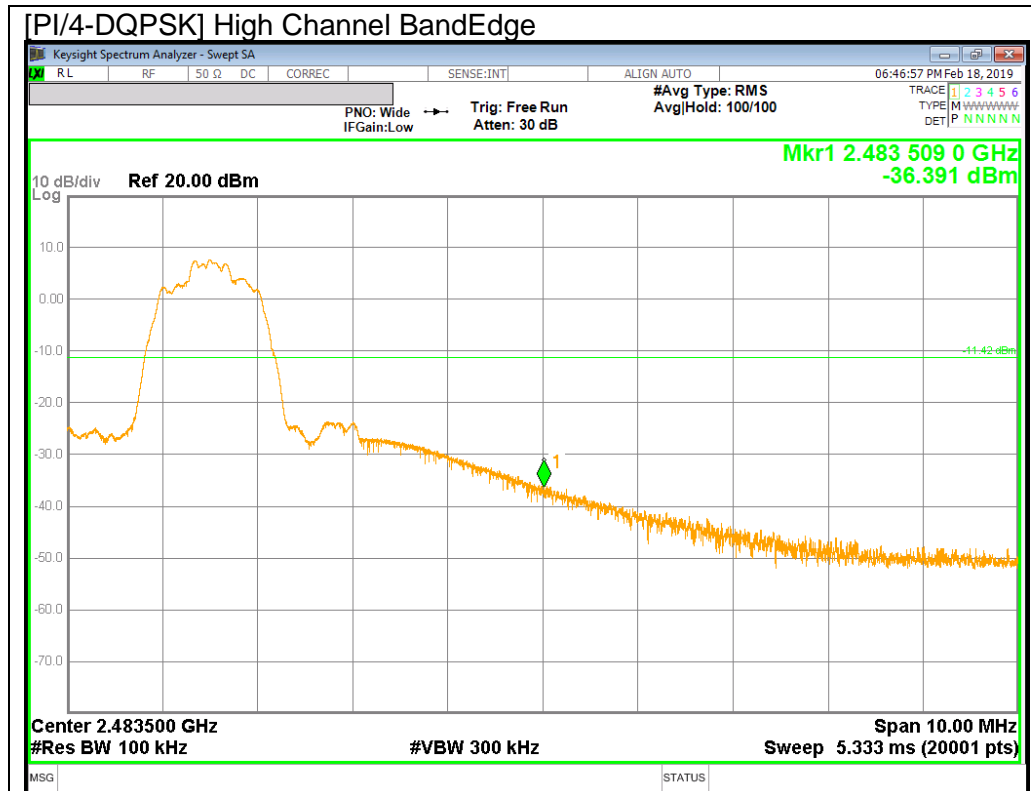

BandEdge Emission at PI/4-DQPSK Hopping Mode

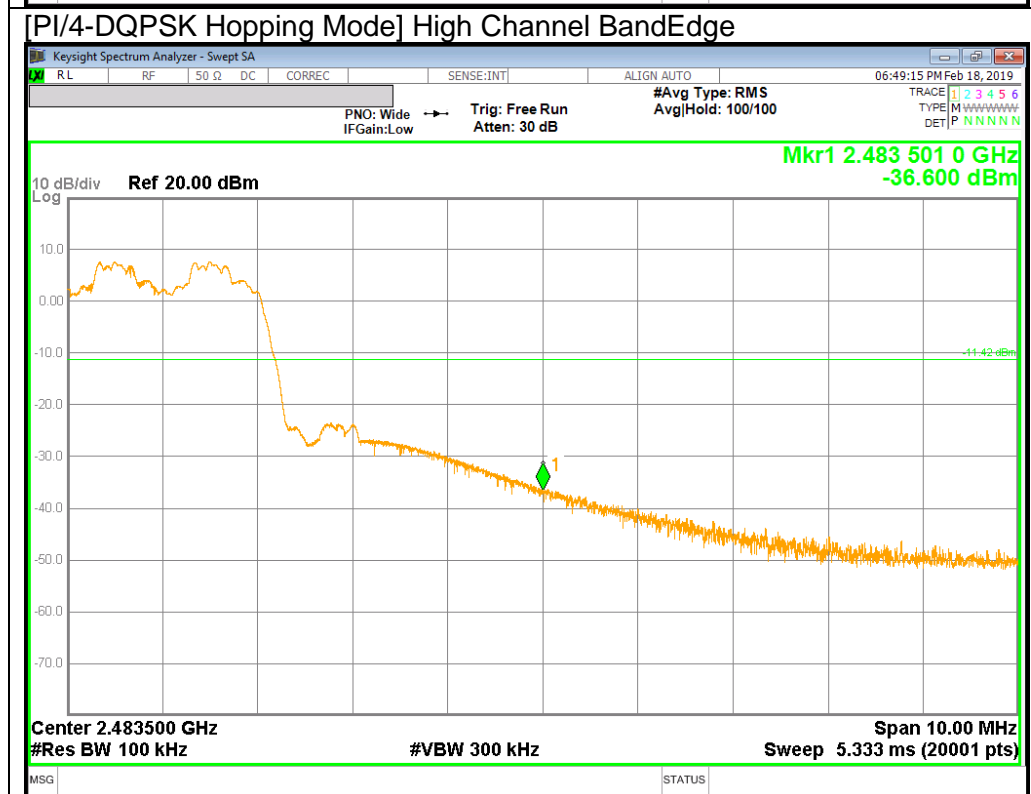
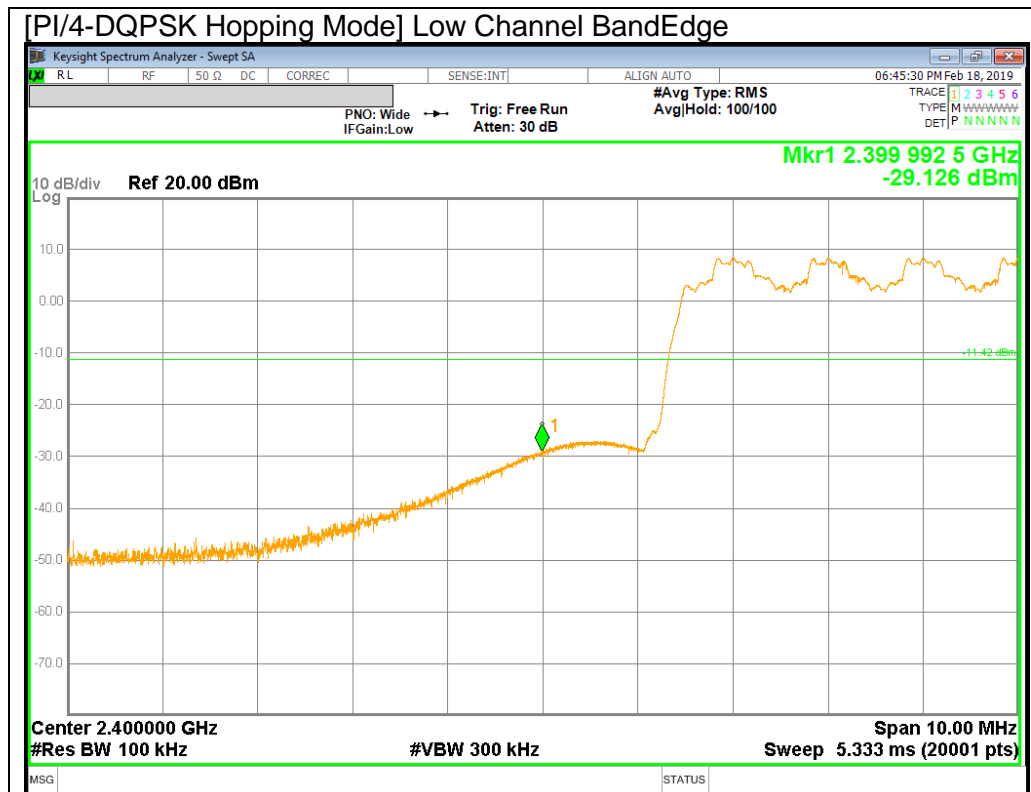

10.6.3. ENHANCED DATA RATE 8PSK MODULATION

8PSK Mode

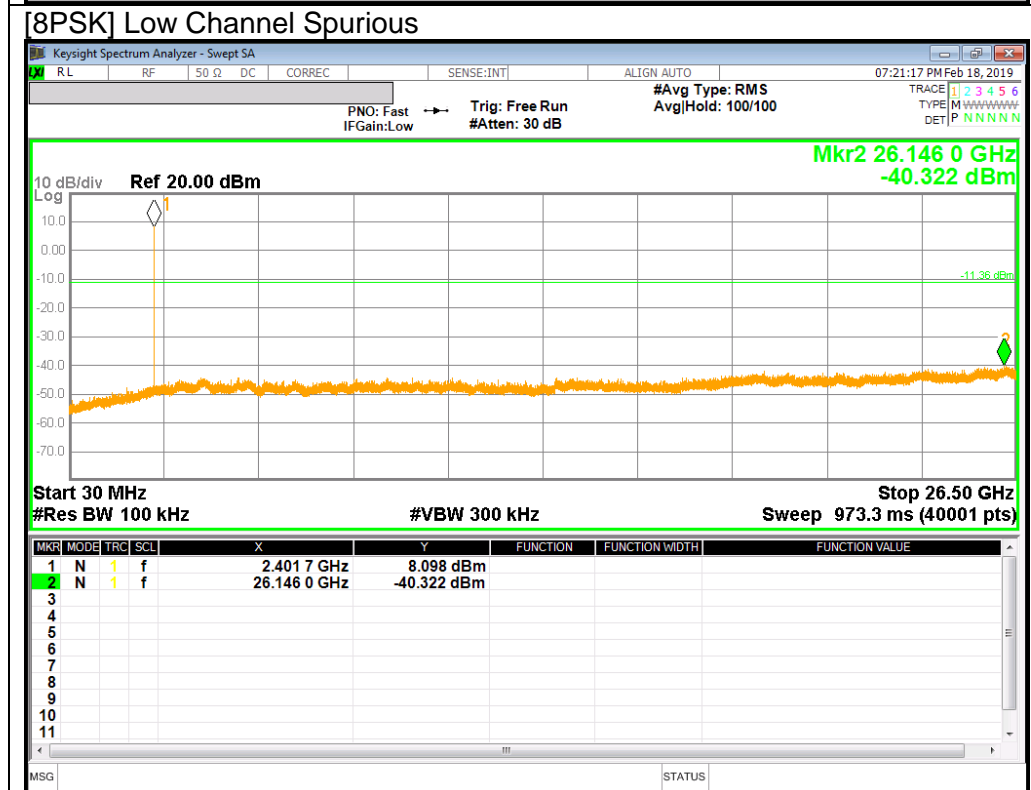
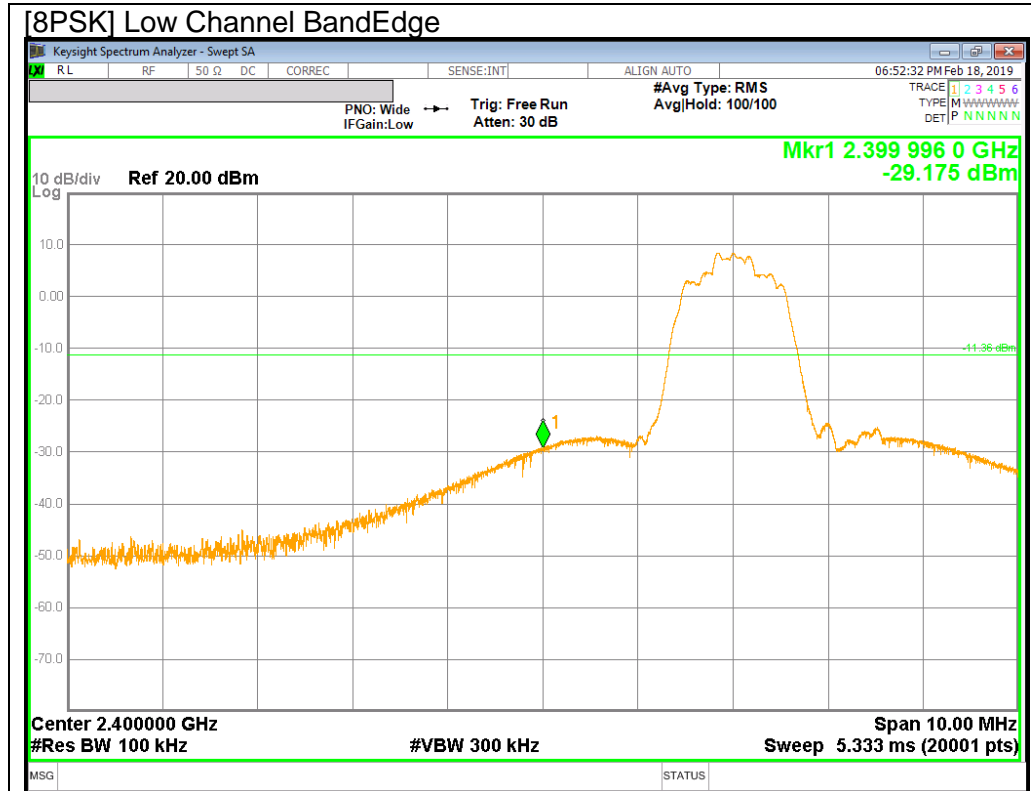

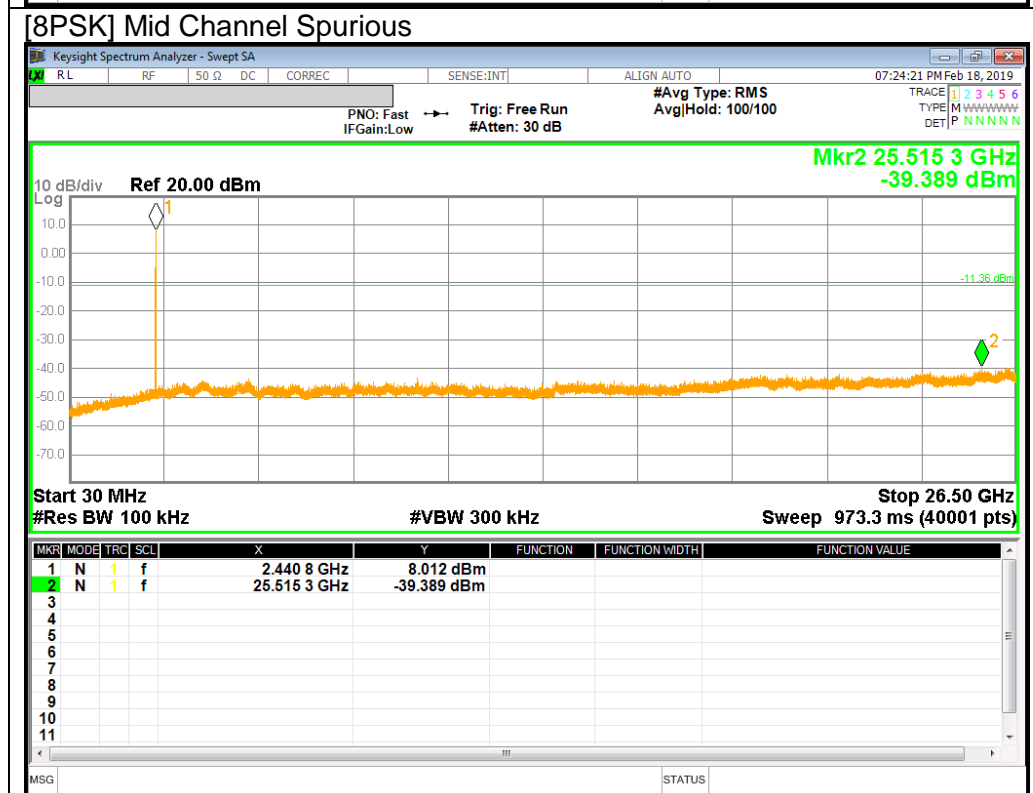
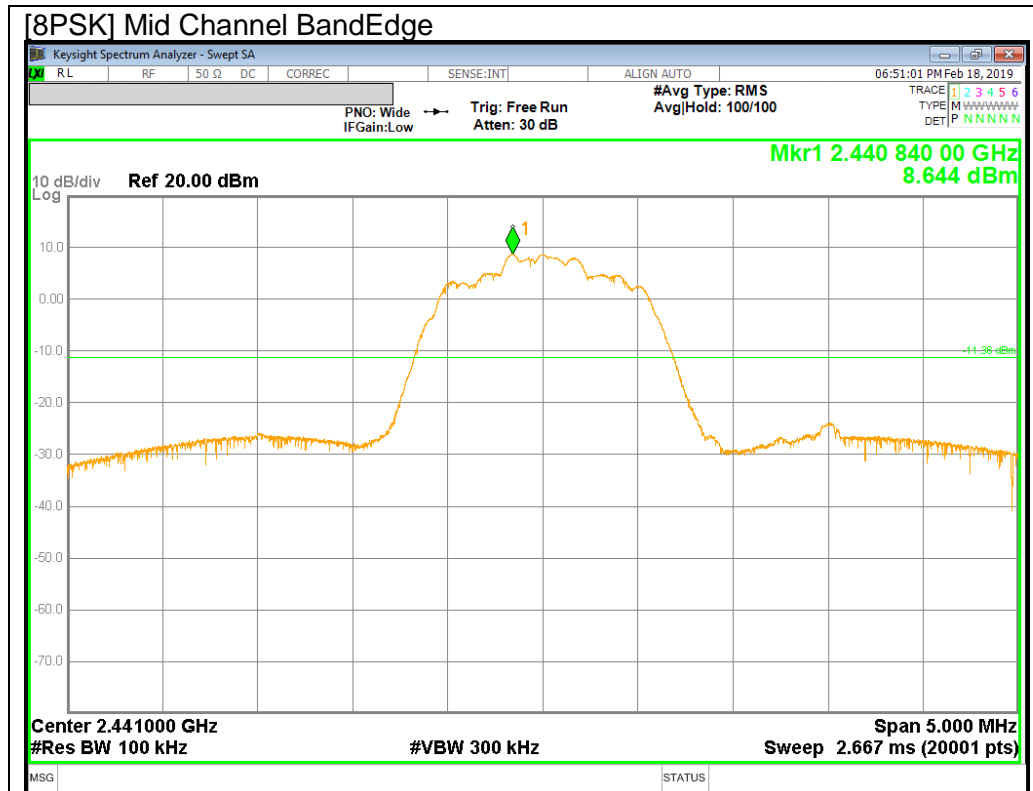

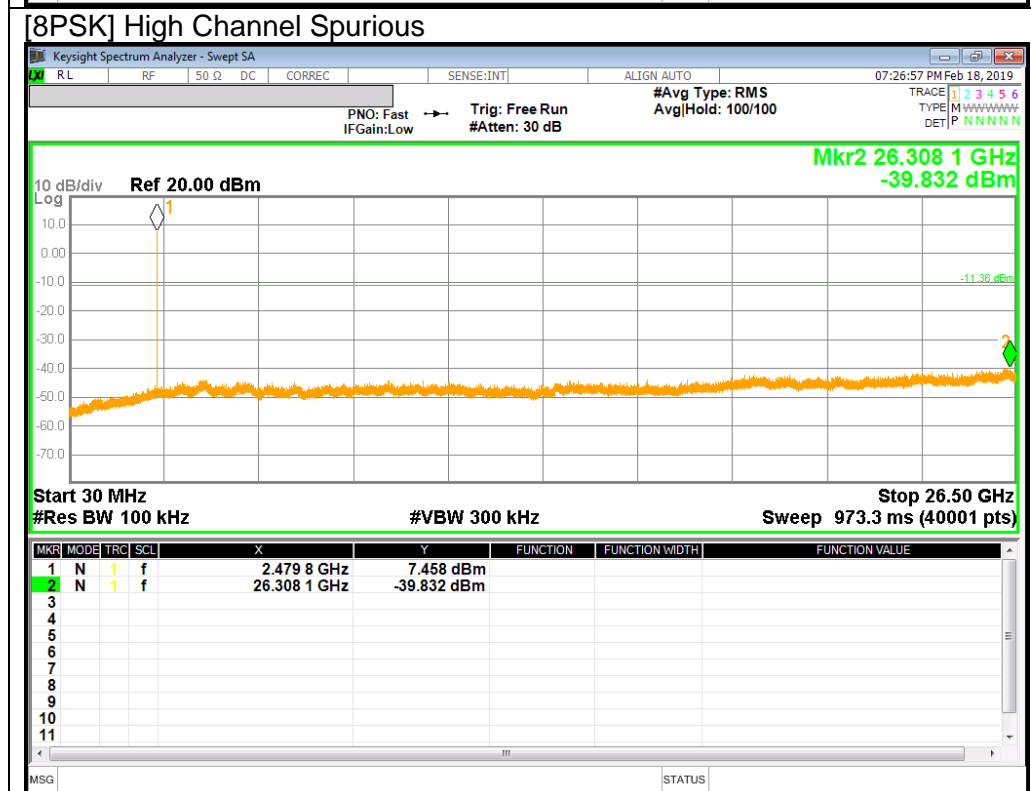
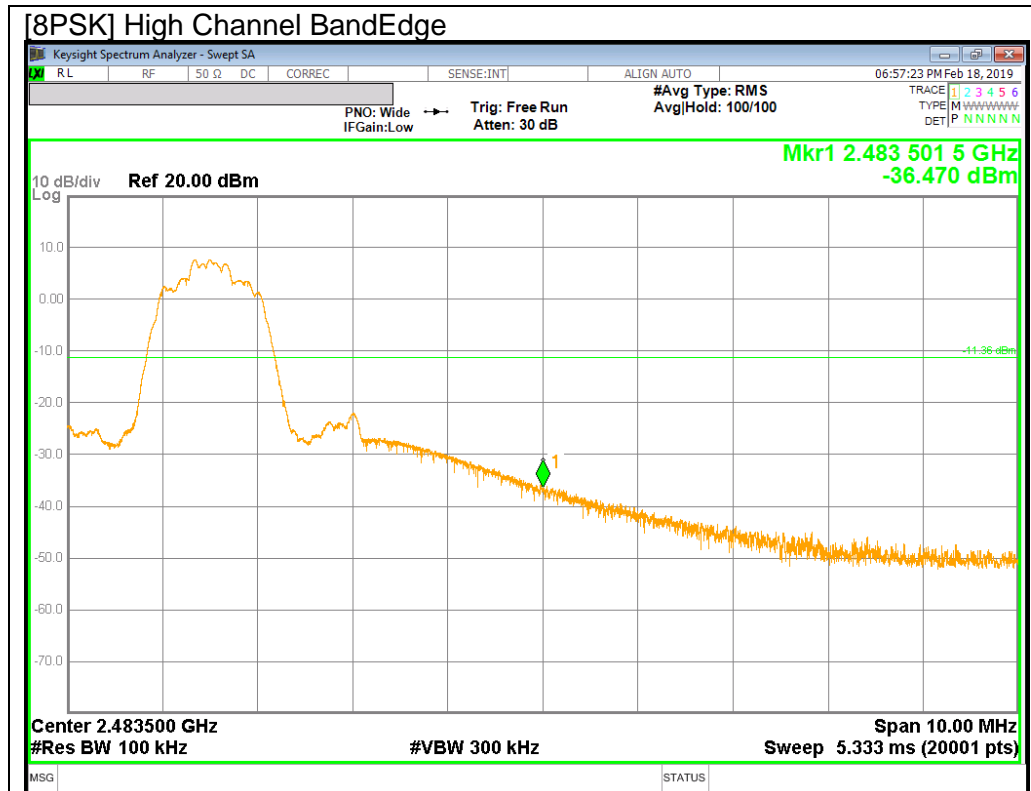

BandEdge Emission at 8PSK Hopping Mode

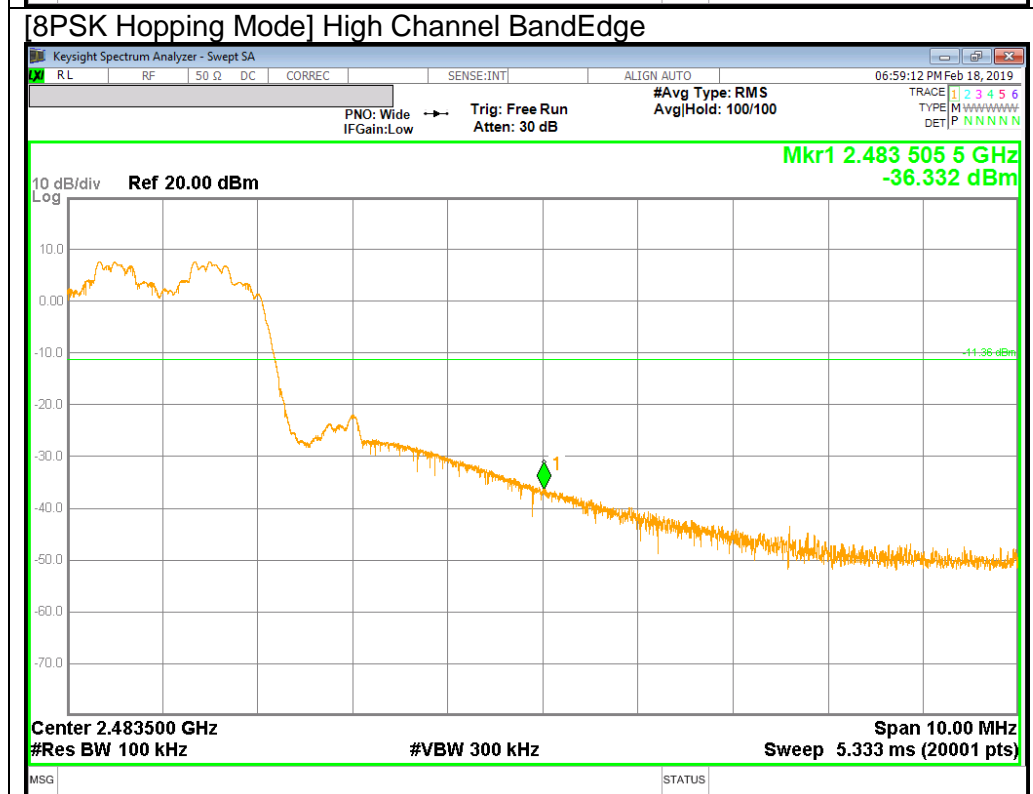
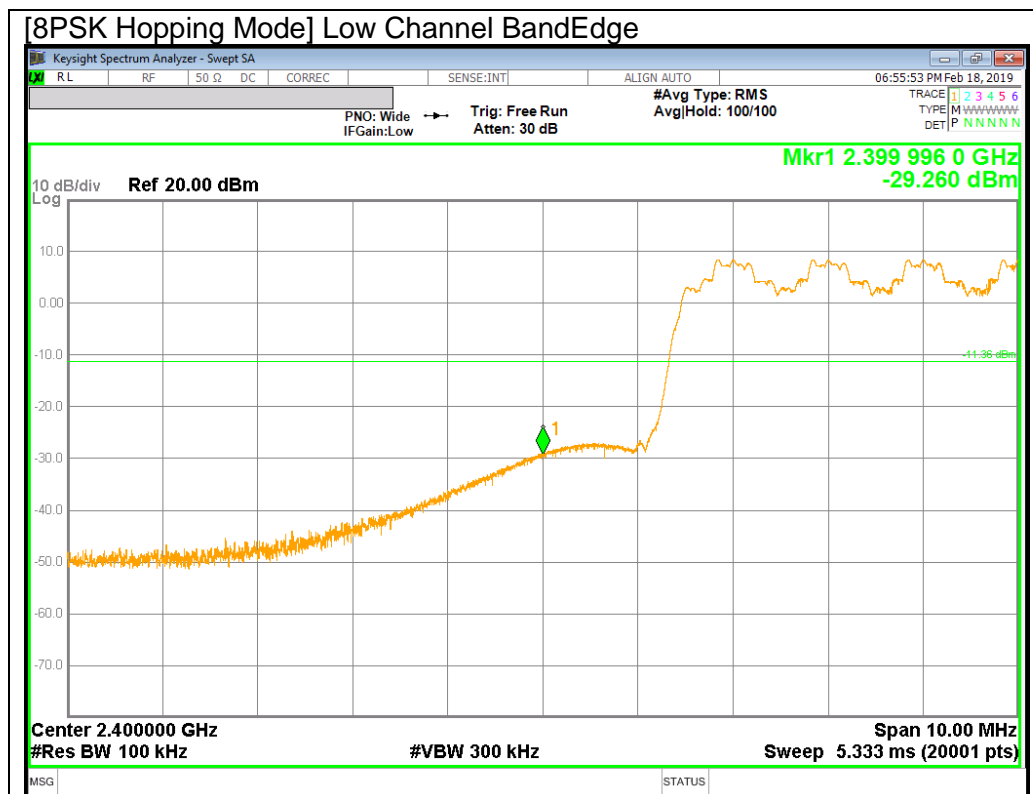

11. RADIATED TEST RESULTS

11.1. LIMITS AND PROCEDURE

LIMITS

FCC §15.205 and §15.209

Limits for radiated disturbance of an intentional radiator		
Frequency range (MHz)	Limits (µV/m)	Measurement Distance (m)
0.009 – 0.490	2400 / F (kHz)	300
0.490 – 1.705	24000 / F (kHz)	30
1.705 – 30.0	30	30
30 – 88	100**	3
88 - 216	150**	3
216 – 960	200**	3
Above 960	500	3

** Except as provided in paragraph (g), fundamental emissions from intentional radiators operating under this section shall not be located in the frequency bands 54-72 MHz, 76-88 MHz, 174-216 MHz or 470-806 MHz. However, operation within these frequency bands is permitted under other sections of this part, e.g. §§ 15.231 and 15.241.

TEST PROCEDURE

The EUT is placed on a non-conducting table 80 cm above the ground plane for below 1GHz and 150 cm for above 1GHz. The EUT is configured in accordance with ANSI C63.10. The EUT is set to transmit in a continuous mode.

For measurements below 1 GHz the resolution bandwidth is set to 100 kHz for peak detection measurements or 120 kHz for quasi-peak detection measurements. Peak detection is used unless otherwise noted as quasi-peak.

For measurements above 1 GHz the resolution bandwidth is set to 1 MHz; the video bandwidth is set to 3 MHz for peak measurements.(Pre-scans to detect harmonic and spurious emissions, the resolution bandwidth is set to 1 MHz; the video bandwidth is set to 30 KHz for peak measurements.)

For band edge measurements above 1 GHz the resolution bandwidth is set to 1 MHz, then the video bandwidth is set to 3 MHz for peak measurements and 1/T (on time) for average measurement.

$$\text{GFSK} = 1/T = 1 / 0.002879\text{S} = 347\text{Hz}.$$

The minimum VBW was 347Hz, but test receiver(ESU40) couldn't set value 347Hz. Due to this reason, testing VBW was set to 500Hz(Worst cases).

The spectrum from 1GHz to 26 GHz is investigated with the transmitter set to the lowest, middle, and highest channels in the 2.4 GHz band.
(From 30MHz to 1GHz, test was performed with the EUT set to transmit at the channel with highest output power)

The frequency range of interest is monitored at a fixed antenna height and EUT azimuth. The EUT is rotated through 360 degrees to maximize emissions received. The antenna is scanned from 1 to 4 meters above the ground plane to further maximize the emission. Measurements are made with the antenna polarized in both the vertical and the horizontal positions.

Note : Emission was pre-scanned from 9KHz to 30MHz; No emissions were detected which was at least 20dB below the specification limit (consider distance correction factor).
Per FCC part 15.31(o), test results were not reported.

Although these tests were performed other than open field test site, adequate comparison measurements were confirmed against 30 m open are test site.
Therefore sufficient tests were made to demonstrate that the alternative site produces results that correlate with the one of tests made in an open field based on KDB 414788.

11.2. TRANSMITTER ABOVE 1 GHz

11.2.1. BASIC DATA RATE GFSK MODULATION

RESTRICTED BANDEDGE (LOW CHANNEL)

HORIZONTAL PEAK AND AVERAGE PLOT

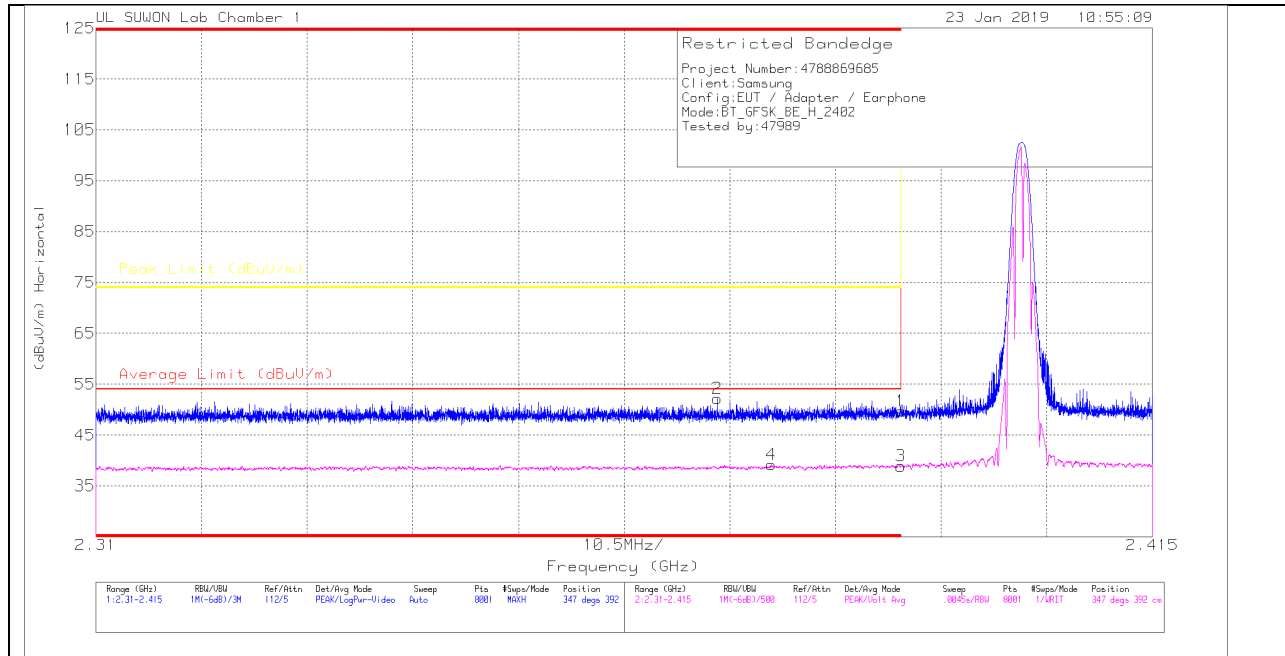

HORIZONTAL DATA

Trace Markers

Marker	Frequency (GHz)	Meter Reading (dBuV)	Det	3117_00168717	10dB[dB]	Corrected Reading (dBuV/m)	Average Limit (dBuV/m)	Margin (dB)	Peak Limit (dBuV/m)	PK Margin (dB)	Azimuth (Degs)	Height (cm)	Polarity
1	* 2.39	43.51	Pk	31.7	-25.5	49.71	-	-	74	-24.29	347	392	H
2	* 2.372	46.14	Pk	31.6	-25.6	52.14	-	-	74	-21.86	347	392	H
3	* 2.39	32.69	VA1T	31.7	-25.5	38.89	54	-15.11	-	-	347	392	H
4	* 2.377	33.15	VA1T	31.6	-25.6	39.15	54	-14.85	-	-	347	392	H

* - indicates frequency in CFR47 Pt 15 / IC RSS-Restricted Band

Pk - Peak detector

VA1T - FHSS: Linear Voltage Average VB=1/Ton where: Ton is transmit duration

VERTICAL PEAK AND AVERAGE PLOT

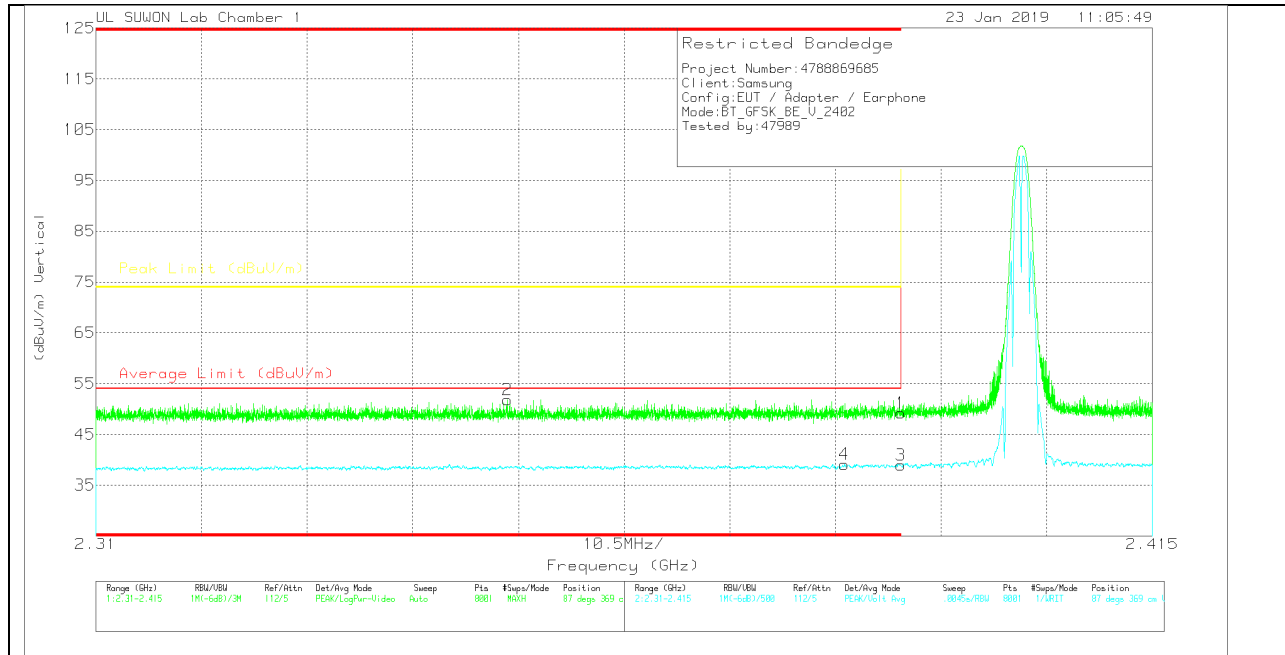

VERTICAL DATA

Trace Markers

Marker	Frequency (GHz)	Meter Reading (dBuV)	Det	3117_00168717	10dB[dB]	Corrected Reading (dBuV/m)	Average Limit (dBuV/m)	Margin (dB)	Peak Limit (dBuV/m)	PK Margin (dB)	Azimuth (Degs)	Height (cm)	Polarity
1	* 2.39	43.04	Pk	31.7	-25.5	49.24	-	-	74	-24.76	87	369	V
2	* 2.351	45.94	Pk	31.6	-25.7	51.84	-	-	74	-22.16	87	369	V
3	* 2.39	32.78	VA1T	31.7	-25.5	38.98	54	-15.02	-	-	87	369	V
4	* 2.384	32.93	VA1T	31.7	-25.5	39.13	54	-14.87	-	-	87	369	V

* - indicates frequency in CFR47 Pt 15 / IC RSS-Restricted Band

Pk - Peak detector

VA1T - FHSS: Linear Voltage Average $V_B=1/T_{on}$ where: T_{on} is transmit duration

AUTHORIZED BANDEDGE (HIGH CHANNEL)

HORIZONTAL PEAK AND AVERAGE PLOT

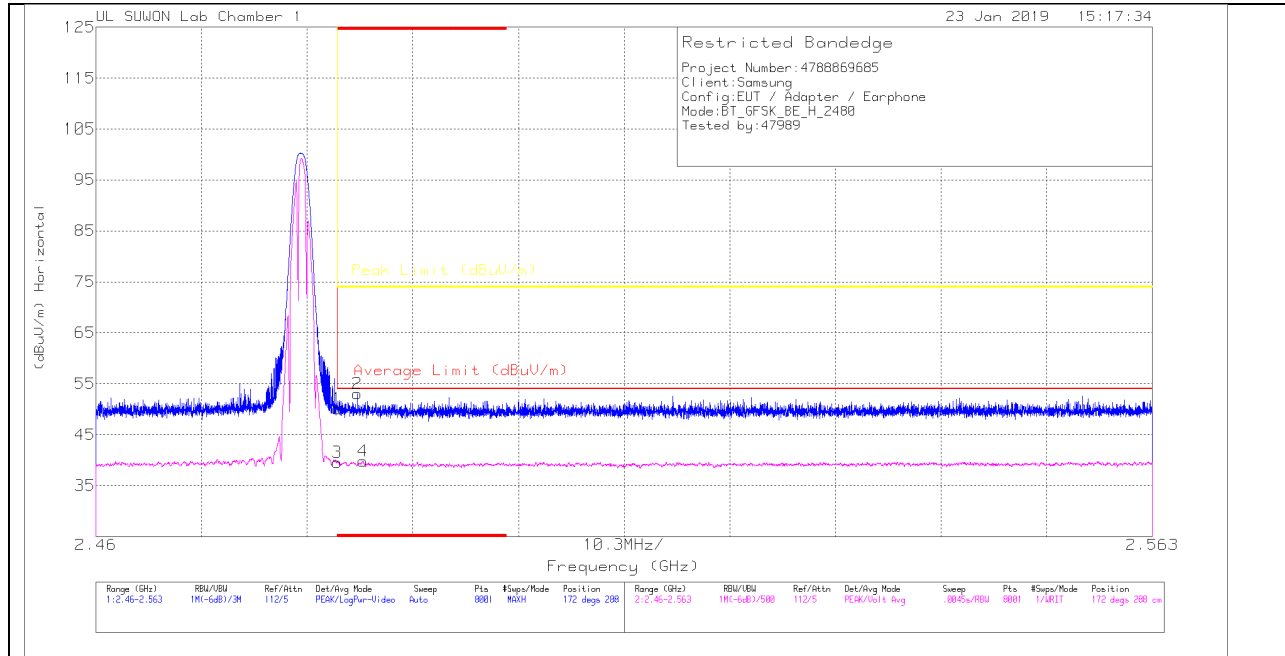

HORIZONTAL DATA

Trace Markers

Marker	Frequency (GHz)	Meter Reading (dBuV)	Det	3117_00168717	10dB[dB]	Corrected Reading (dBuV/m)	Average Limit (dBuV/m)	Margin (dB)	Peak Limit (dBuV/m)	PK Margin (dB)	Azimuth (Degs)	Height (cm)	Polarity
1	* 2.484	43.43	Pk	31.9	-25.3	50.03	-	-	74	-23.97	172	288	H
2	* 2.485	46.42	Pk	31.9	-25.3	53.02	-	-	74	-20.98	172	288	H
3	* 2.484	33	VA1T	31.9	-25.3	39.6	54	-14.4	-	-	172	288	H
4	* 2.486	33.08	VA1T	31.9	-25.2	39.78	54	-14.22	-	-	172	288	H

* - indicates frequency in CFR47 Pt 15 / IC RSS-Restricted Band

Pk - Peak detector

VA1T - FHSS: Linear Voltage Average $VB=1/Ton$ where: Ton is transmit duration

VERTICAL PEAK AND AVERAGE PLOT

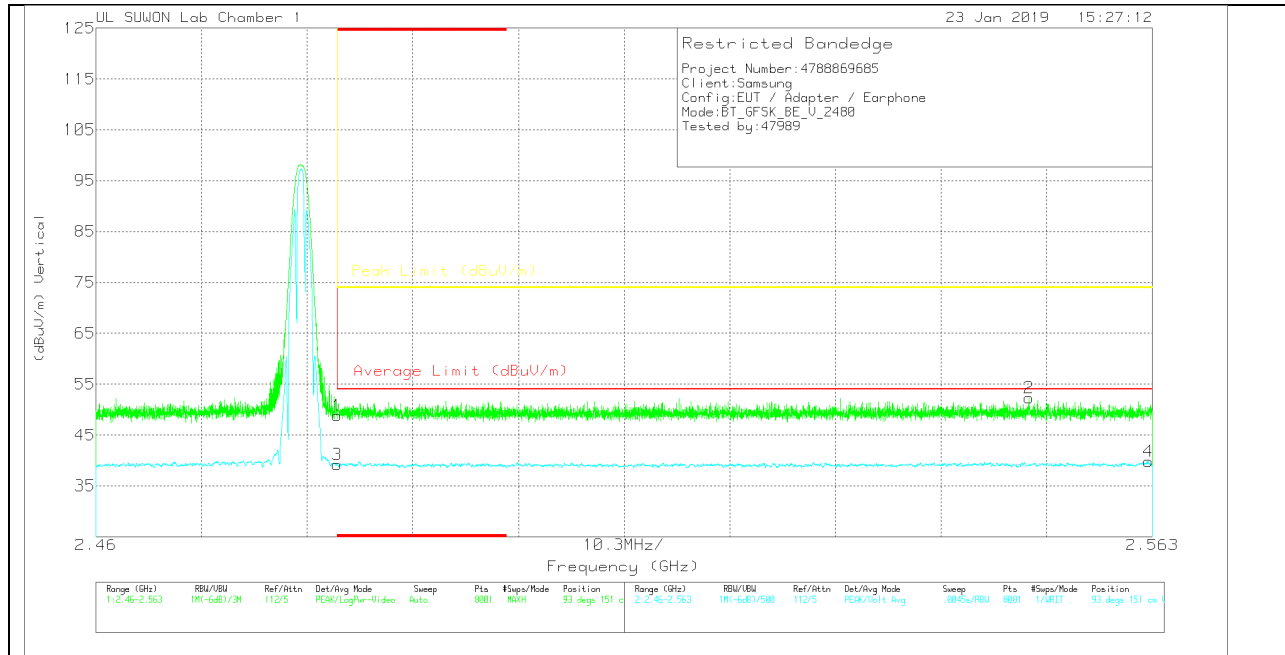

VERTICAL DATA

Trace Markers

Marker	Frequency (GHz)	Meter Reading (dBuV)	Det	3117_00168717	10dB[dB]	Corrected Reading (dBuV/m)	Average Limit (dBuV/m)	Margin (dB)	Peak Limit (dBuV/m)	PK Margin (dB)	Azimuth (Degs)	Height (cm)	Polarity
1	* 2.484	42.21	Pk	31.9	-25.3	48.81	-	-	74	-25.19	93	151	V
2	2.551	45.35	Pk	32	-25.1	52.25	-	-	74	-21.75	93	151	V
3	* 2.484	32.62	VA1T	31.9	-25.3	39.22	54	-14.78	-	-	93	151	V
4	2.563	32.91	VA1T	32	-25.1	39.81	54	-14.19	-	-	93	151	V

* - indicates frequency in CFR47 Pt 15 / IC RSS-Restricted Band

Pk - Peak detector

VA1T - FHSS: Linear Voltage Average VB=1/Ton where: Ton is transmit duration

HARMONICS AND SPURIOUS EMISSIONS

LOW CHANNEL HORIZONTAL

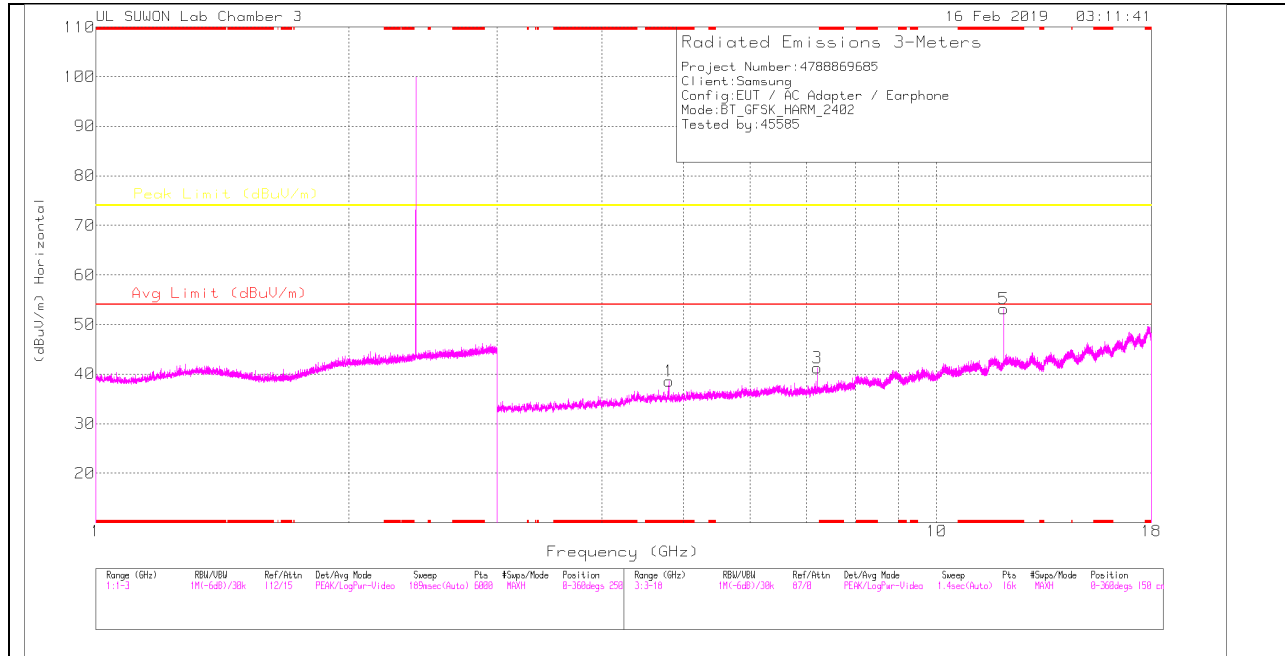

LOW CHANNEL VERTICAL

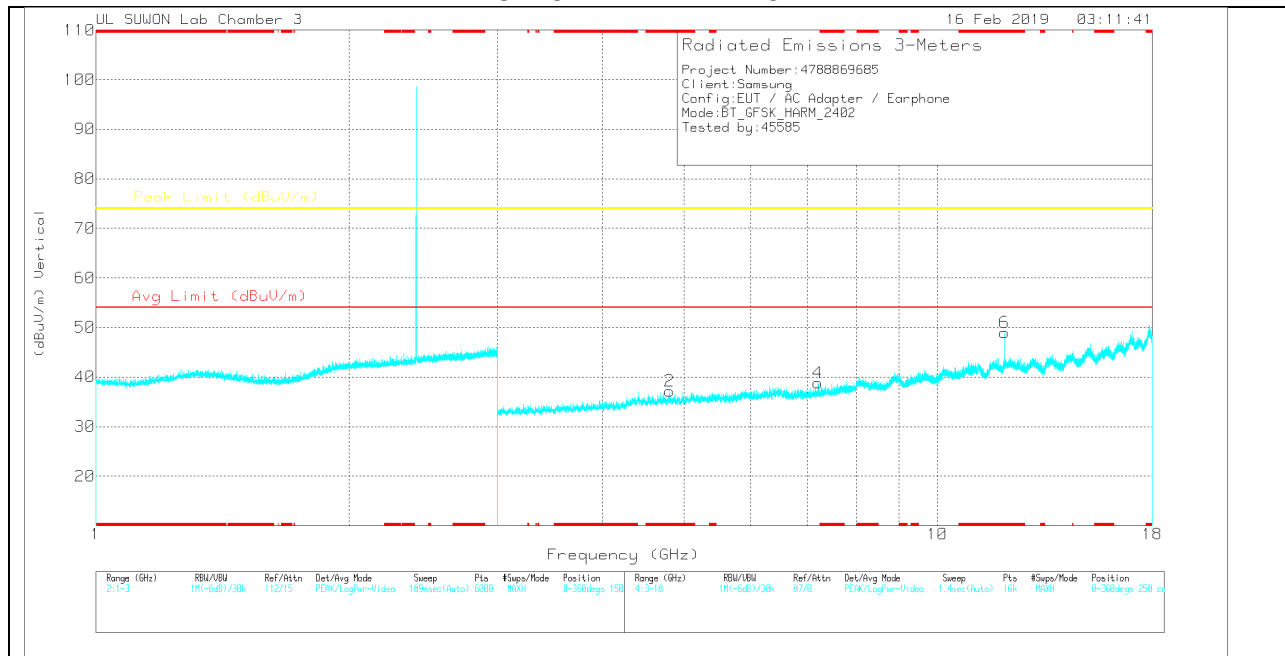

Note: Emission was scanned up to 26GHz; No emissions were detected above the noise floor which was at least 20dB below the specification limit.

LOW CHANNEL DATA

Trace Markers

Marker	Frequency (GHz)	Meter Reading (dBuV)	Det	3117_00205959	3GHz_HP[dB]	Corrected Reading (dBuV/m)	Avg Limit (dBuV/m)	Margin (dB)	Peak Limit (dBuV/m)	Margin (dB)	Azimuth (Degs)	Height (cm)	Polarity
1	* 4.804	32.72	PK	34.2	-28.4	38.52	-	-	74	-35.48	0-360	250	H
3	7.206	29.61	PK	35.8	-24.2	41.21	-	-	74	-32.79	0-360	150	H
5	* 12.011	34.26	PK	39	-20.1	53.16	-	-	74	-20.84	0-360	250	H
2	* 4.804	31.36	PK	34.2	-28.4	37.16	-	-	74	-36.84	0-360	150	V
4	7.206	27.21	PK	35.8	-24.2	38.81	-	-	74	-35.19	0-360	250	V
6	* 12.009	30.03	PK	39	-20	49.03	-	-	74	-24.97	0-360	150	V

* - indicates frequency in CFR47 Pt 15 / IC RSS-Restricted Band
 PK – Peak Detector

Radiated Emissions

Frequency (GHz)	Meter Reading (dBuV)	Det	3117_00205959	3GHz_HP[dB]	Corrected Reading (dBuV/m)	Avg Limit (dBuV/m)	Margin (dB)	Peak Limit (dBuV/m)	Margin (dB)	Azimuth (Degs)	Height (cm)	Polarity
* 4.804	39.28	PKFH	34.2	-28.4	45.08	-	-	74	-28.92	197	385	H
* 4.804	28.3	VA1T	34.2	-28.4	34.1	54	-19.9	-	-	197	385	H
* 4.804	40.49	PKFH	34.2	-28.4	46.29	-	-	74	-27.71	210	301	V
* 4.804	29.48	VA1T	34.2	-28.4	35.28	54	-18.72	-	-	210	301	V
7.206	37.36	PKFH	35.8	-24.2	48.96	-	-	74	-25.04	141	179	H
7.206	24.73	VA1T	35.8	-24.2	36.33	-	-	-	-	141	179	H
7.206	36.95	PKFH	35.8	-24.2	48.55	-	-	74	-25.45	142	126	V
7.206	25.93	VA1T	35.8	-24.2	37.53	-	-	-	-	142	126	V
* 12.01	39.39	PKFH	39	-20.1	58.29	-	-	74	-15.71	177	228	V
* 12.011	29.94	VA1T	39	-20.1	48.84	54	-5.16	-	-	177	228	V
* 12.01	37.4	PKFH	39	-20.1	56.3	-	-	74	-17.7	275	135	H
* 12.011	27.19	VA1T	39	-20.1	46.09	54	-7.91	-	-	275	135	H

* - indicates frequency in CFR47 Pt 15 / IC RSS-Restricted Band
 PKFH - FHSS: RB=100k/1MHz VB=3 x RB, Peak
 VA1T - FHSS: Linear Voltage Average VB=1/Ton where: Ton is transmit duration

MID CHANNEL HORIZONTAL

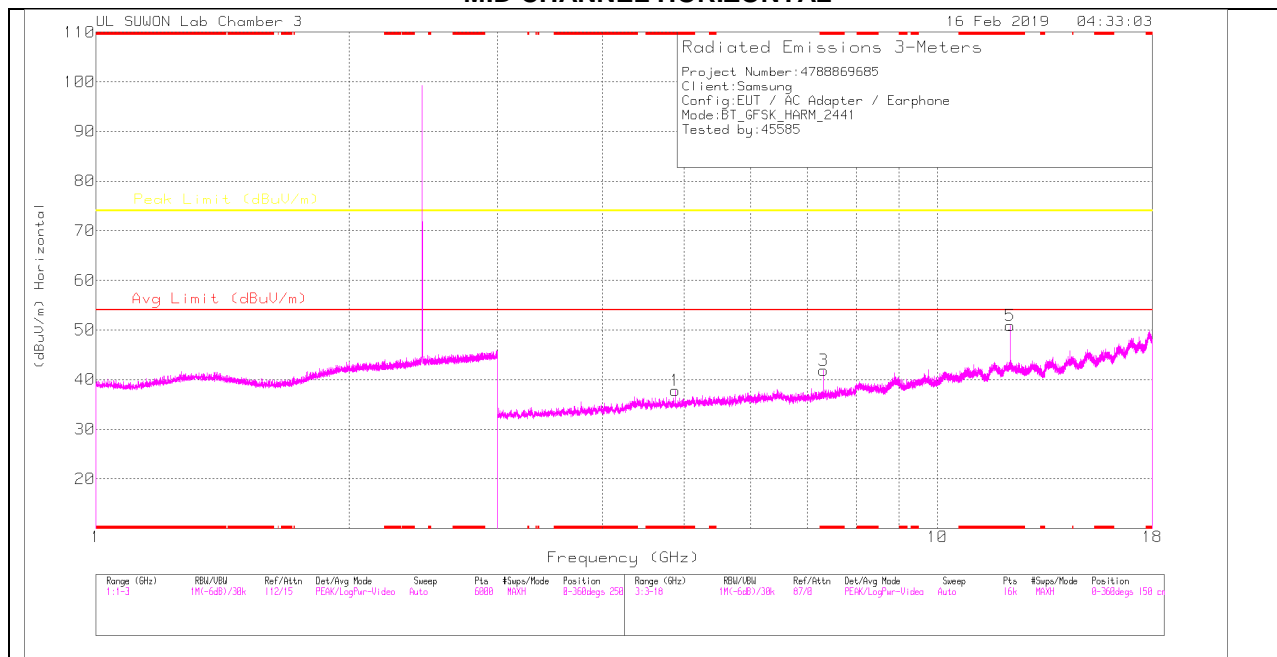

MID CHANNEL VERTICAL

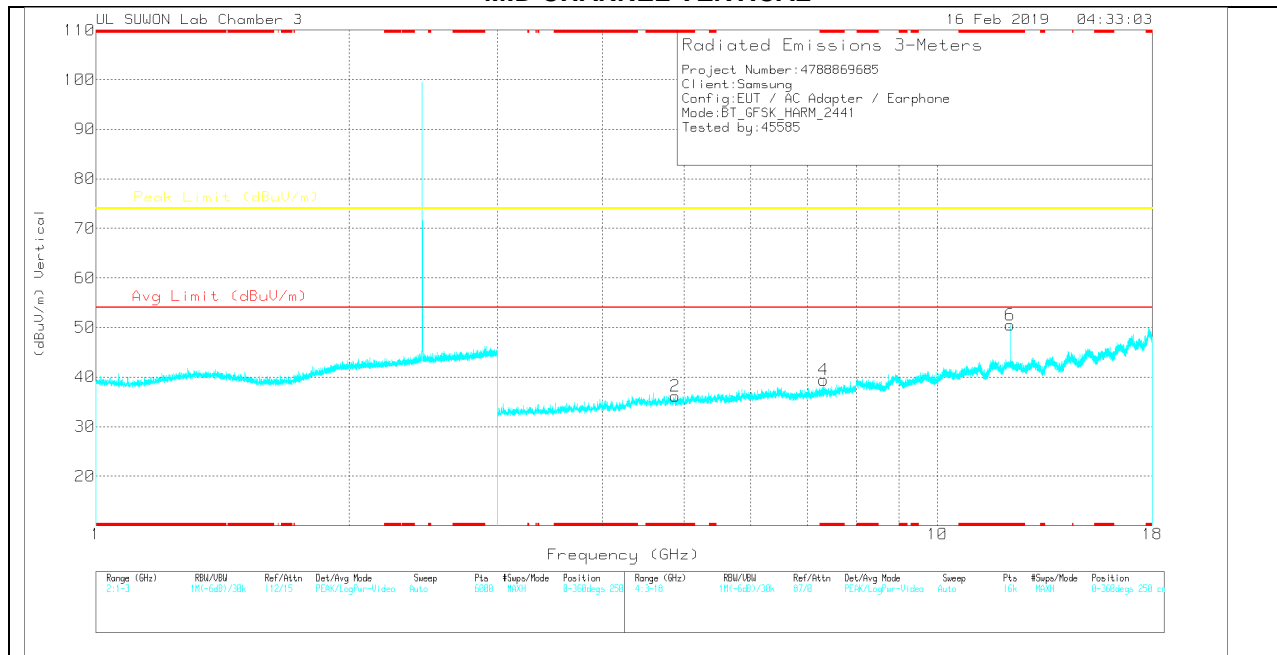

Note: Emission was scanned up to 26GHz; No emissions were detected above the noise floor which was at least 20dB below the specification limit.

MID CHANNEL DATA

Trace Markers

Marker	Frequency (GHz)	Meter Reading (dBuV)	Det	3117_00205959	3GHz_HP[dB]	Corrected Reading (dBuV/m)	Avg Limit (dBuV/m)	Margin (dB)	Peak Limit (dBuV/m)	Margin (dB)	Azimuth (Degs)	Height (cm)	Polarity
1	* 4.882	32.77	PK	34.2	-29.2	37.77	-	-	74	-36.23	0-360	250	H
3	* 7.323	29.65	PK	35.8	-23.6	41.85	-	-	74	-32.15	0-360	150	H
5	* 12.206	31.56	PK	39	-19.7	50.86	-	-	74	-23.14	0-360	250	H
2	* 4.882	31.15	PK	34.2	-29.2	36.15	-	-	74	-37.85	0-360	150	V
4	* 7.322	27.2	PK	35.8	-23.6	39.4	-	-	74	-34.6	0-360	250	V
6	* 12.205	31.26	PK	39	-19.8	50.46	-	-	74	-23.54	0-360	150	V

* - indicates frequency in CFR47 Pt 15 / IC RSS-Restricted Band
 PK – Peak Detector

Radiated Emissions

Frequency (GHz)	Meter Reading (dBuV)	Det	3117_00205959	3GHz_HP[dB]	Corrected Reading (dBuV/m)	Avg Limit (dBuV/m)	Margin (dB)	Peak Limit (dBuV/m)	Margin (dB)	Azimuth (Degs)	Height (cm)	Polarity
* 4.882	31.15	VA1T	34.2	-29.2	36.15	54	-17.85	-	-	136	257	H
* 4.882	41.06	PKFH	34.2	-29.2	46.06	-	-	74	-27.94	136	257	H
* 4.882	41.27	PKFH	34.2	-29.2	46.27	-	-	74	-27.73	197	116	V
* 4.882	30.69	VA1T	34.2	-29.2	35.69	54	-18.31	-	-	197	116	V
* 7.323	33.13	PKFH	35.8	-23.6	45.33	-	-	74	-28.67	31	197	V
* 7.323	21.43	VA1T	35.8	-23.6	33.63	54	-20.37	-	-	31	197	V
* 7.323	39.86	PKFH	35.8	-23.6	52.06	-	-	74	-21.94	175	104	H
* 7.323	30.43	VA1T	35.8	-23.6	42.63	54	-11.37	-	-	175	104	H
* 12.205	37.25	PKFH	39	-19.8	56.45	-	-	74	-17.55	306	400	H
* 12.205	26.41	VA1T	39	-19.8	45.61	54	-8.39	-	-	306	400	H
* 12.205	39.09	PKFH	39	-19.8	58.29	-	-	74	-15.71	178	226	V
* 12.205	28.61	VA1T	39	-19.8	47.81	54	-6.19	-	-	178	226	V

* - indicates frequency in CFR47 Pt 15 / IC RSS-Restricted Band
 PKFH - FHSS: RB=100k/1MHz VB=3 x RB, Peak
 VA1T - FHSS: Linear Voltage Average VB=1/Ton where: Ton is transmit duration

HIGH CHANNEL HORIZONTAL

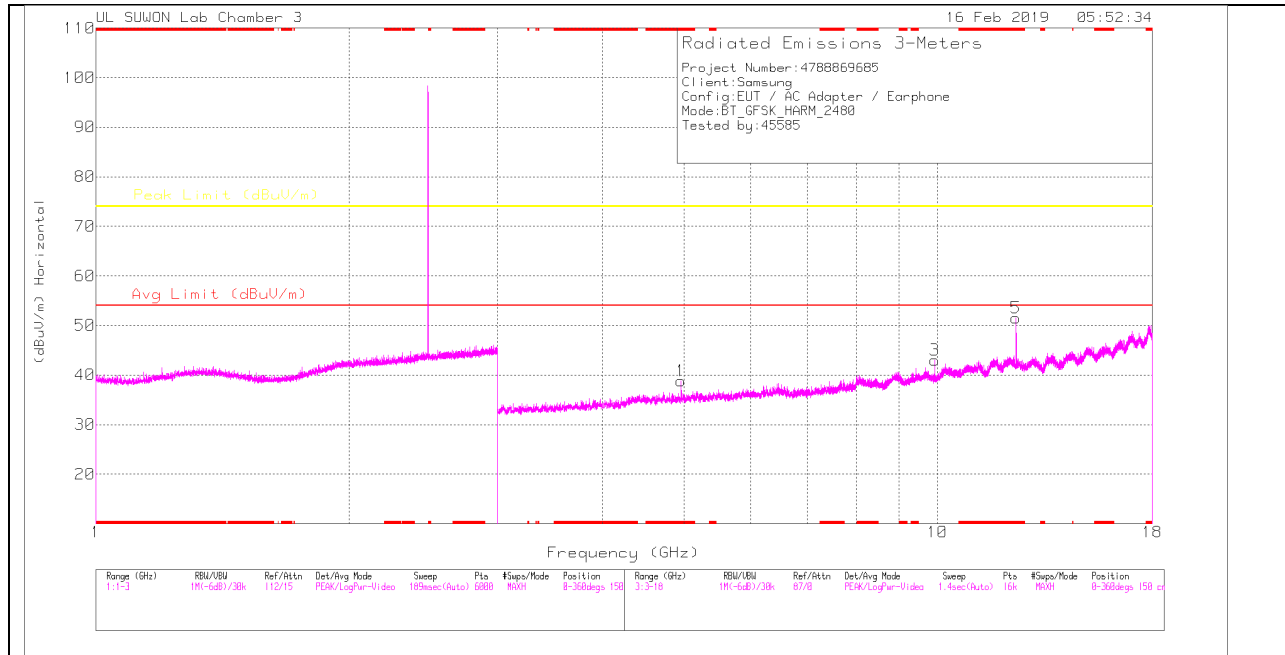

HIGH CHANNEL VERTICAL

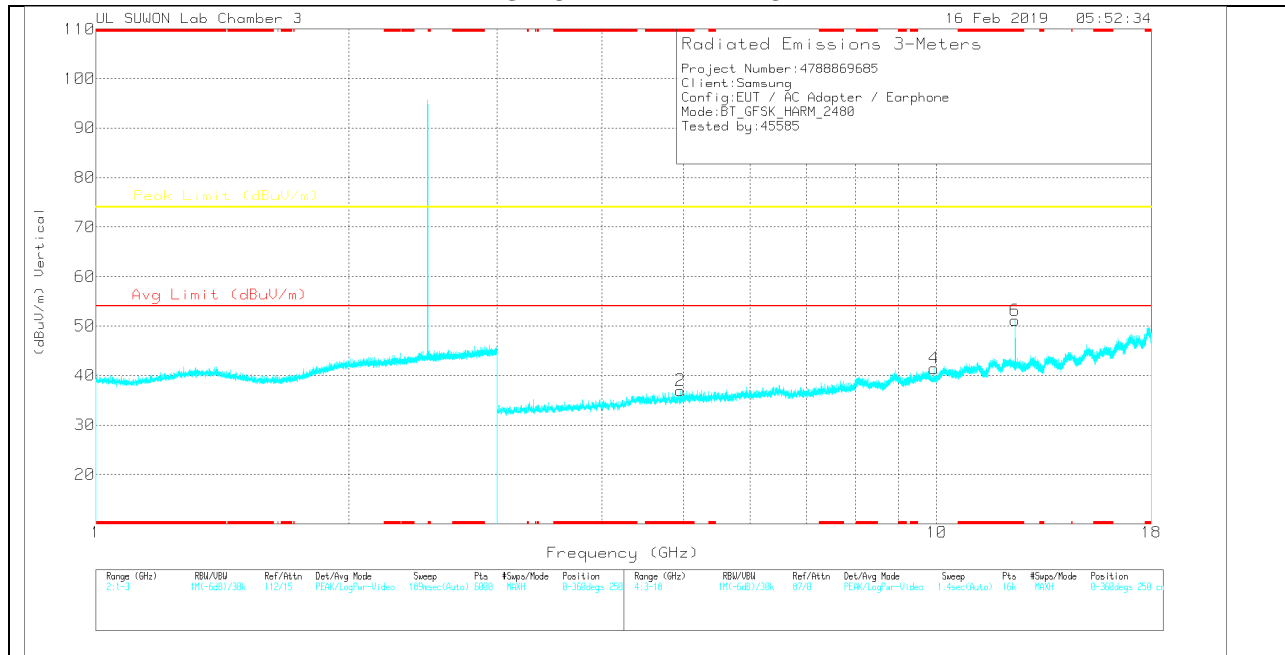

Note: Emission was scanned up to 26GHz; No emissions were detected above the noise floor which was at least 20dB below the specification limit.

HIGH CHANNEL DATA

Trace Markers

Marker	Frequency (GHz)	Meter Reading (dBuV)	Det	3117_00205959	3GHz_HP[dB]	Corrected Reading (dBuV/m)	Avg Limit (dBuV/m)	Margin (dB)	Peak Limit (dBuV/m)	Margin (dB)	Azimuth (Degs)	Height (cm)	Polarity
1	* 4.959	33.5	PK	34.2	-28.9	38.8	-	-	74	-35.2	0-360	250	H
3	9.92	25.26	PK	37.5	-19.7	43.06	-	-	74	-30.94	0-360	250	H
5	* 12.401	32.91	PK	38.8	-20.2	51.51	-	-	74	-22.49	0-360	150	H
2	* 4.959	31.68	PK	34.2	-28.9	36.98	-	-	74	-37.02	0-360	150	V
4	9.92	23.63	PK	37.5	-19.7	41.43	-	-	74	-32.57	0-360	150	V
6	* 12.399	32.49	PK	38.9	-20.2	51.19	-	-	74	-22.81	0-360	250	V

* - indicates frequency in CFR47 Pt 15 / IC RSS-Restricted Band
 PK – Peak Detector

Radiated Emissions

Frequency (GHz)	Meter Reading (dBuV)	Det	3117_00205959	3GHz_HP[dB]	Corrected Reading (dBuV/m)	Avg Limit (dBuV/m)	Margin (dB)	Peak Limit (dBuV/m)	Margin (dB)	Azimuth (Degs)	Height (cm)	Polarity
* 4.96	41.37	PKFH	34.2	-28.9	46.67	-	-	74	-27.33	140	278	H
* 4.96	31.25	VA1T	34.2	-28.9	36.55	54	-17.45	-	-	140	278	H
* 4.96	41.18	PKFH	34.2	-28.9	46.48	-	-	74	-27.52	210	122	V
* 4.96	30.63	VA1T	34.2	-28.9	35.93	54	-18.07	-	-	210	122	V
9.92	33.09	PKFH	37.5	-19.7	50.89	-	-	74	-23.11	156	135	V
9.92	21.79	VA1T	37.5	-19.7	39.59	-	-	-	-	156	135	V
9.92	33.44	PKFH	37.5	-19.7	51.24	-	-	74	-22.76	23	105	H
9.92	22.07	VA1T	37.5	-19.7	39.87	-	-	-	-	23	105	H
* 12.4	41.44	PKFH	38.8	-20.2	60.04	-	-	74	-13.96	186	100	H
* 12.401	32.55	VA1T	38.8	-20.2	51.15	54	-2.85	-	-	186	100	H
* 12.401	40.25	PKFH	38.8	-20.2	58.85	-	-	74	-15.15	130	100	V
* 12.401	31.41	VA1T	38.8	-20.2	50.01	54	-3.99	-	-	130	100	V

* - indicates frequency in CFR47 Pt 15 / IC RSS-Restricted Band
 PKFH - FHSS: RB=100k/1MHz VB=3 x RB, Peak
 VA1T - FHSS: Linear Voltage Average VB=1/Ton where: Ton is transmit duration

11.2.2. ENHANCED DATA RATE 8PSK MODULATION RESTRICTED BANDEDGE (LOW CHANNEL)

HORIZONTAL PEAK AND AVERAGE PLOT

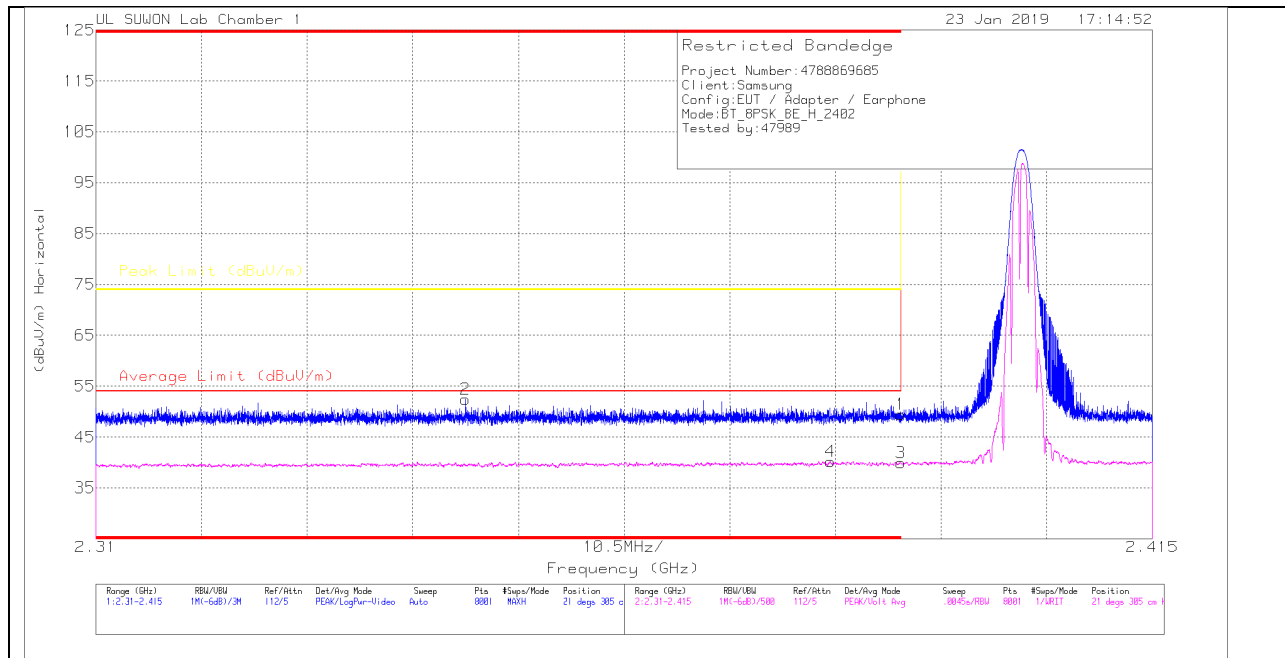

HORIZONTAL DATA

Trace Markers

Marker	Frequency (GHz)	Meter Reading (dBuV)	Det	3117_00168717	10dB(dB)	DC Corr (dB)	Corrected Reading (dBuV/m)	Average Limit (dBuV/m)	Margin (dB)	Peak Limit (dBuV/m)	PK Margin (dB)	Azimuth (Degs)	Height (cm)	Polarity
1	* 2.39	43.24	Pk	31.7	-25.5	0	49.44	-	-	74	-24.56	21	305	H
2	* 2.347	46.49	Pk	31.6	-25.7	0	52.39	-	-	74	-21.61	21	305	H
3	* 2.39	32.59	VA1T	31.7	-25.5	0	38.79	54	-15.21	-	-	21	305	H
4	* 2.383	32.97	VA1T	31.7	-25.6	0	39.07	54	-14.93	-	-	21	305	H

* - indicates frequency in CFR47 Pt 15 / IC RSS-Restricted Band

Pk - Peak detector

VA1T - FHSS: Linear Voltage Average $VB=1/T_{on}$ where: T_{on} is transmit duration

VERTICAL PEAK AND AVERAGE PLOT

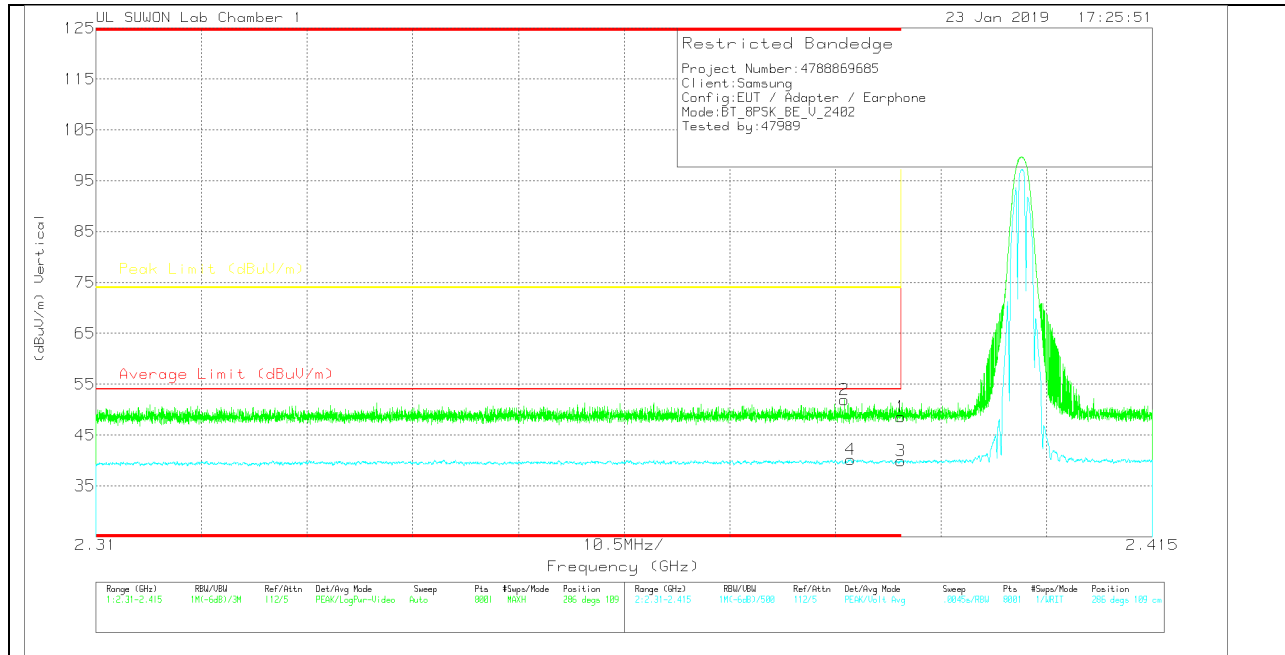

VERTICAL DATA

Trace Markers

Marker	Frequency (GHz)	Meter Reading (dBu)	Det	3117_00168717	10dB[dB]	DC Corr (dB)	Corrected Reading (dBu/m)	Average Limit (dBu/m)	Margin (dB)	Peak Limit (dBu/m)	PK Margin (dB)	Azimuth (Degs)	Height (cm)	Polarity
1	* 2.39	42.45	Pk	31.7	-25.5	0	48.65	-	-	74	-25.35	286	109	V
2	* 2.384	45.72	Pk	31.7	-25.5	0	51.92	-	-	74	-22.08	286	109	V
3	* 2.39	32.59	VA1T	31.7	-25.5	0	38.79	54	-15.21	-	-	286	109	V
4	* 2.385	32.87	VA1T	31.7	-25.5	0	39.07	54	-14.93	-	-	286	109	V

* - indicates frequency in CFR47 Pt 15 / IC RSS-Restricted Band

Pk - Peak detector

VA1T - FHSS: Linear Voltage Average VB=1/Ton where: Ton is transmit duration

AUTHORIZED BANDEDGE (HIGH CHANNEL)

HORIZONTAL PEAK AND AVERAGE PLOT

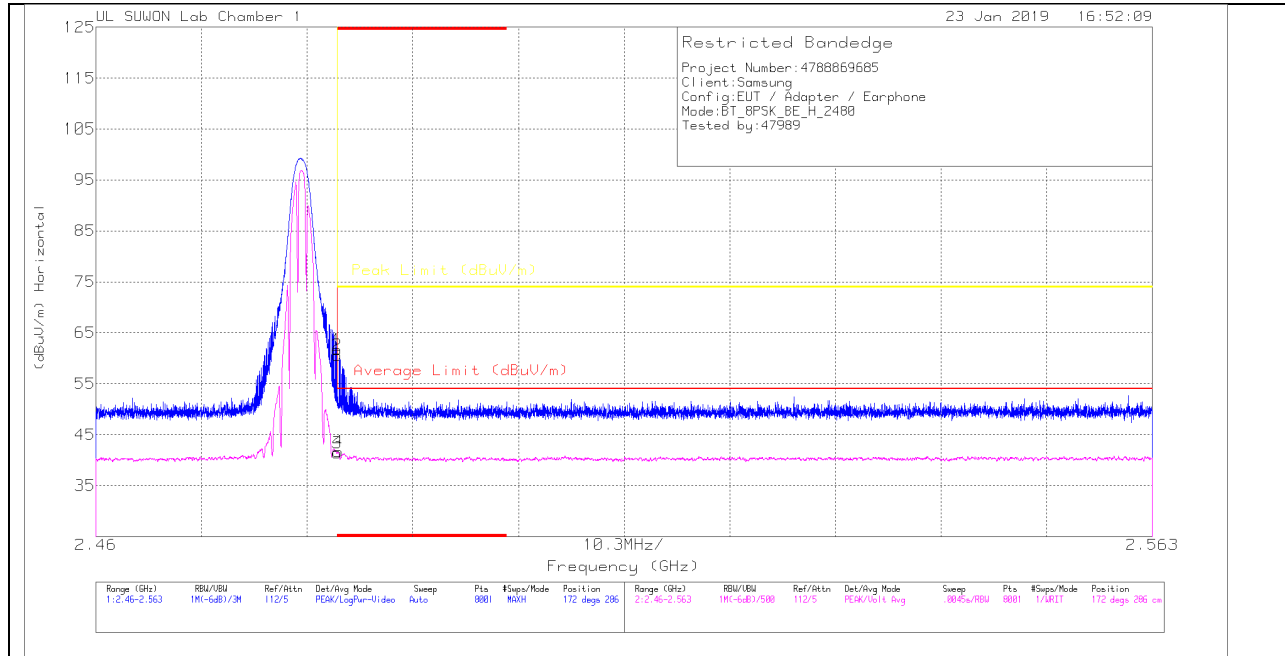

HORIZONTAL DATA

Trace Markers

Marker	Frequency (GHz)	Meter Reading (dBuV)	Det	3117_00168717	10dB(dB)	DC Corr (dB)	Corrected Reading (dBuV/m)	Average Limit (dBuV/m)	Margin (dB)	Peak Limit (dBuV/m)	PK Margin (dB)	Azimuth (Degs)	Height (cm)	Polarity
1	* 2.484	55.06	Pk	31.9	-25.3	0	61.66	-	-	74	-12.34	172	286	H
2	* 2.484	53.96	Pk	31.9	-25.3	0	60.56	-	-	74	-13.44	172	286	H
3	* 2.484	33.69	VA1T	31.9	-25.3	0	40.29	54	-	-	-	172	286	H
4	* 2.484	33.94	VA1T	31.9	-25.3	0	40.54	54	-13.46	-	-	172	286	H

* - indicates frequency in CFR47 Pt 15 / IC RSS-Restricted Band

Pk - Peak detector

VA1T - FHSS: Linear Voltage Average VB=1/Ton where: Ton is transmit duration

VERTICAL PEAK AND AVERAGE PLOT

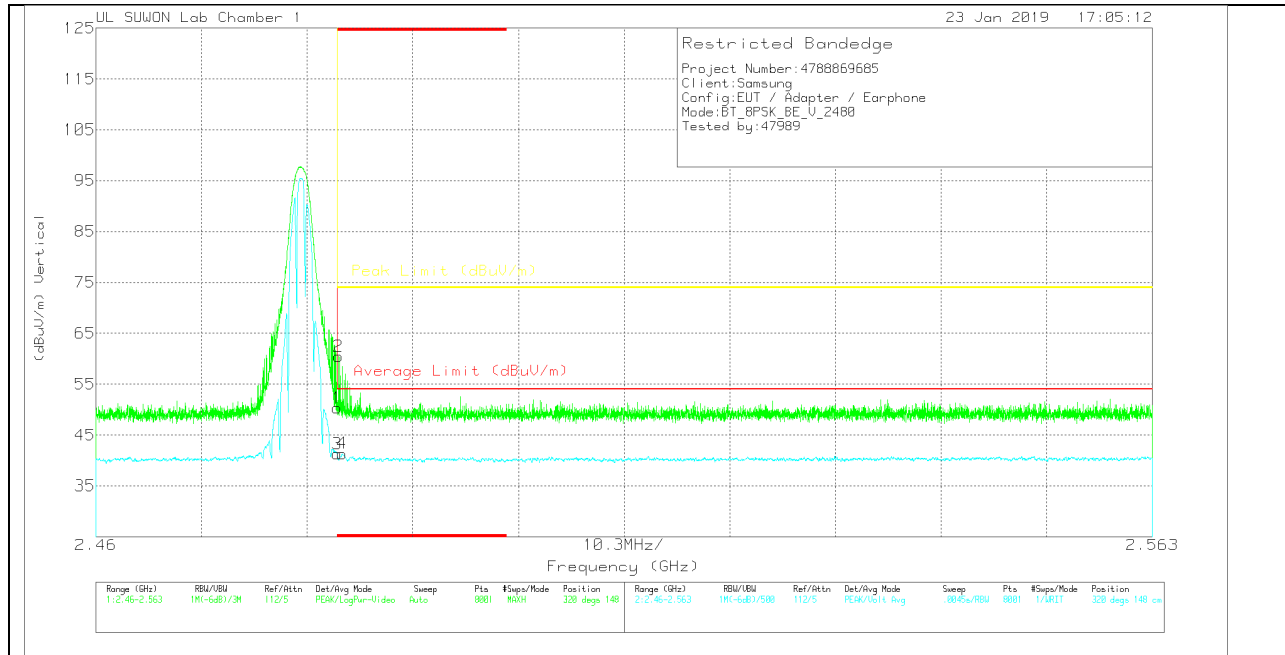

VERTICAL DATA

Trace Markers

Marker	Frequency (GHz)	Meter Reading (dBuV)	Det	3117_00168717	10dB(dB)	DC Corr (dB)	Corrected Reading (dBuV/m)	Average Limit (dBuV/m)	Margin (dB)	Peak Limit (dBuV/m)	PK Margin (dB)	Azimuth (Degs)	Height (cm)	Polarity
1	* 2.484	43.68	Pk	31.9	-25.3	0	50.28	-	-	74	-23.72	320	148	V
2	* 2.484	53.92	Pk	31.9	-25.3	0	60.52	-	-	74	-13.48	320	148	V
3	* 2.484	33.56	VA1T	31.9	-25.3	0	40.16	54	-13.84	-	-	320	148	V
4	* 2.484	33.61	VA1T	31.9	-25.3	0	40.21	54	-13.79	-	-	320	148	V

* - indicates frequency in CFR47 Pt 15 / IC RSS-Restricted Band

Pk - Peak detector

VA1T - FHSS: Linear Voltage Average $V_B=1/T_{on}$ where: T_{on} is transmit duration

HARMONICS AND SPURIOUS EMISSIONS

LOW CHANNEL HORIZONTAL

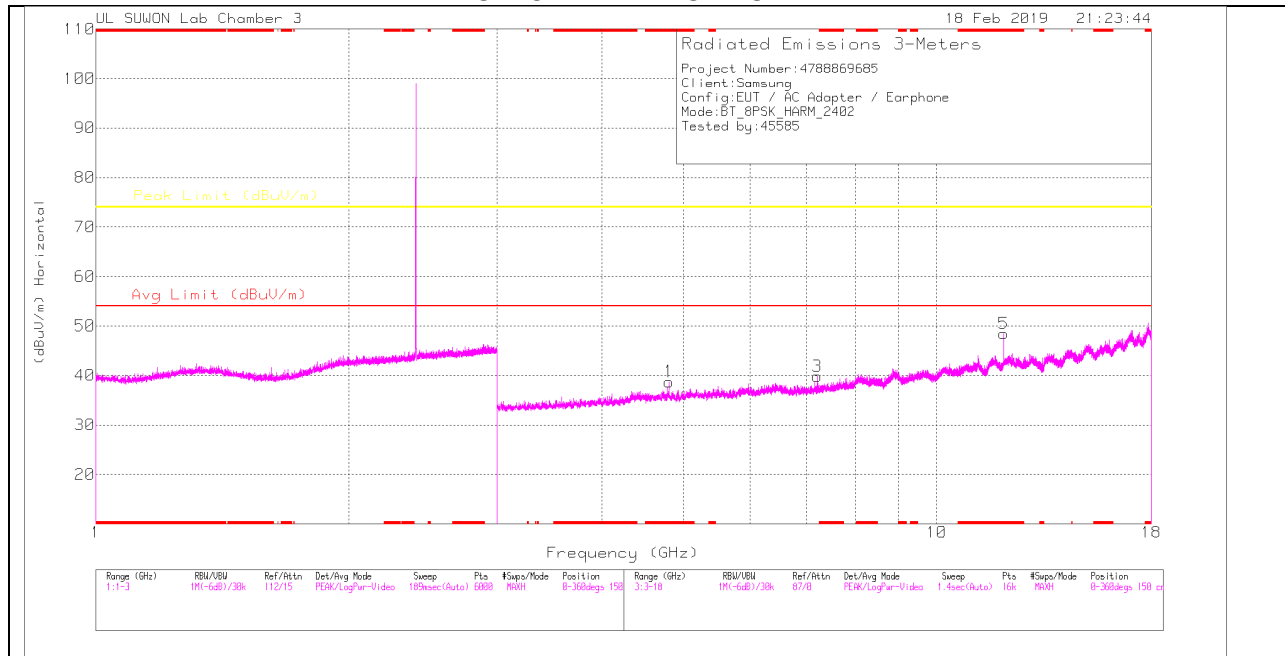

LOW CHANNEL VERTICAL

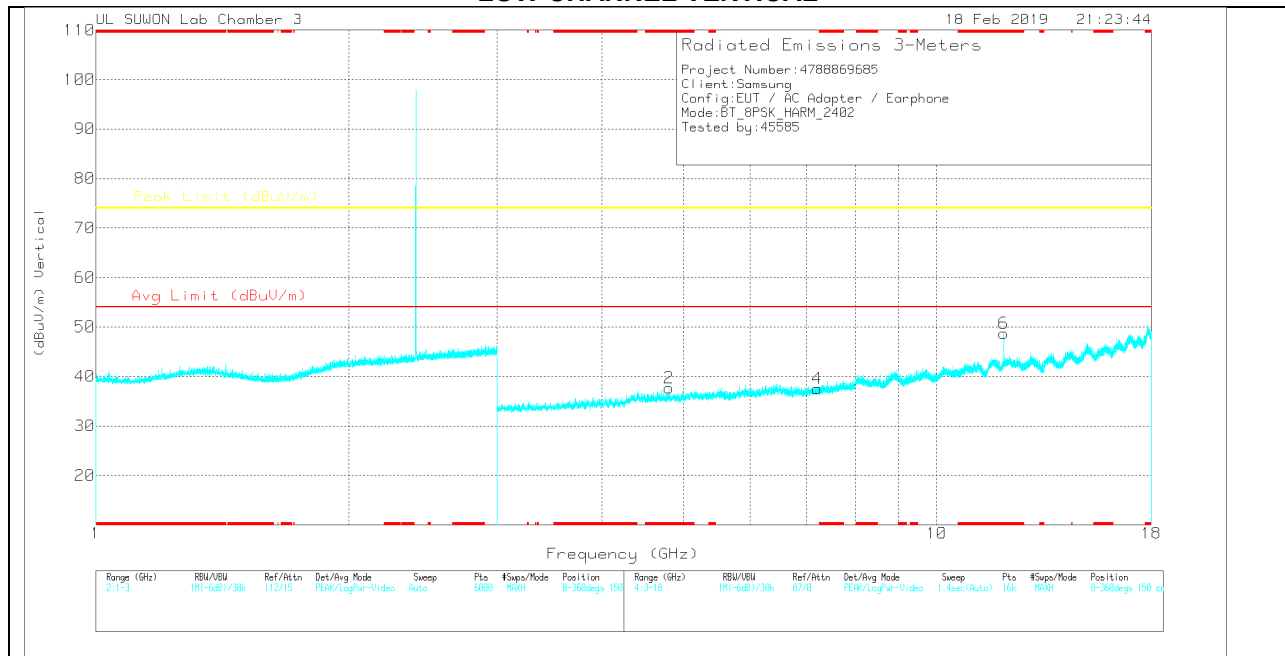

Note: Emission was scanned up to 26GHz; No emissions were detected above the noise floor which was at least 20dB below the specification limit.

LOW CHANNEL DATA

Trace Markers

Marker	Frequency (GHz)	Meter Reading (dBuV)	Det	3117_00205959	3GHz_HP[dB]	Corrected Reading (dBuV/m)	Avg Limit (dBuV/m)	Margin (dB)	Peak Limit (dBuV/m)	Margin (dB)	Azimuth (Degs)	Height (cm)	Polarity
1	* 4.804	32.96	PK	34.2	-28.4	38.76	-	-	74	-35.24	0-360	250	H
3	7.205	28.26	PK	35.8	-24.2	39.86	-	-	74	-34.14	0-360	150	H
5	* 12.01	29.54	PK	39	-20.1	48.44	-	-	74	-25.56	0-360	250	H
2	* 4.804	31.85	PK	34.2	-28.4	37.65	-	-	74	-36.35	0-360	150	V
4	7.205	25.91	PK	35.8	-24.2	37.51	-	-	74	-36.49	0-360	250	V
6	* 12.01	29.83	PK	39	-20.1	48.73	-	-	74	-25.27	0-360	250	V

* - indicates frequency in CFR47 Pt 15 / IC RSS-Restricted Band
 Peak - Peak Detector

Radiated Emissions

Frequency (GHz)	Meter Reading (dBuV)	Det	3117_00205959	3GHz_HP[dB]	Corrected Reading (dBuV/m)	Avg Limit (dBuV/m)	Margin (dB)	Peak Limit (dBuV/m)	Margin (dB)	Azimuth (Degs)	Height (cm)	Polarity
* 4.804	41.78	PKFH	34.2	-28.4	47.58	-	-	74	-26.42	196	149	H
* 4.804	30.86	VA1T	34.2	-28.4	36.66	54	-17.34	-	-	196	149	H
* 4.804	40.66	PKFH	34.2	-28.4	46.46	-	-	74	-27.54	218	170	V
* 4.804	30.14	VA1T	34.2	-28.4	35.94	54	-18.06	-	-	218	170	V
7.206	38.5	PKFH	35.8	-24.2	50.1	-	-	74	-23.9	122	100	V
7.206	21.06	VA1T	35.8	-24.2	32.66	-	-	-	-	122	100	V
7.206	38.42	PKFH	35.8	-24.2	50.02	-	-	74	-23.98	182	105	H
7.206	21.16	VA1T	35.8	-24.2	32.76	-	-	-	-	182	104	H
* 12.011	39.57	PKFH	39	-20.1	58.47	-	-	74	-15.53	251	244	H
* 12.01	27.3	VA1T	39	-20.1	46.2	54	-7.8	-	-	251	244	H
* 12.009	37.03	PKFH	39	-20.1	55.93	-	-	74	-18.07	89	149	V
* 12.01	24.38	VA1T	39	-20.1	43.28	54	-10.72	-	-	89	149	V

* - indicates frequency in CFR47 Pt 15 / IC RSS-Restricted Band
 PKFH - FHSS: RB=100k/1MHz VB=3 x RB, Peak
 VA1T - FHSS: Linear Voltage Average VB=1/Ton where: Ton is transmit duration

MID CHANNEL HORIZONTAL

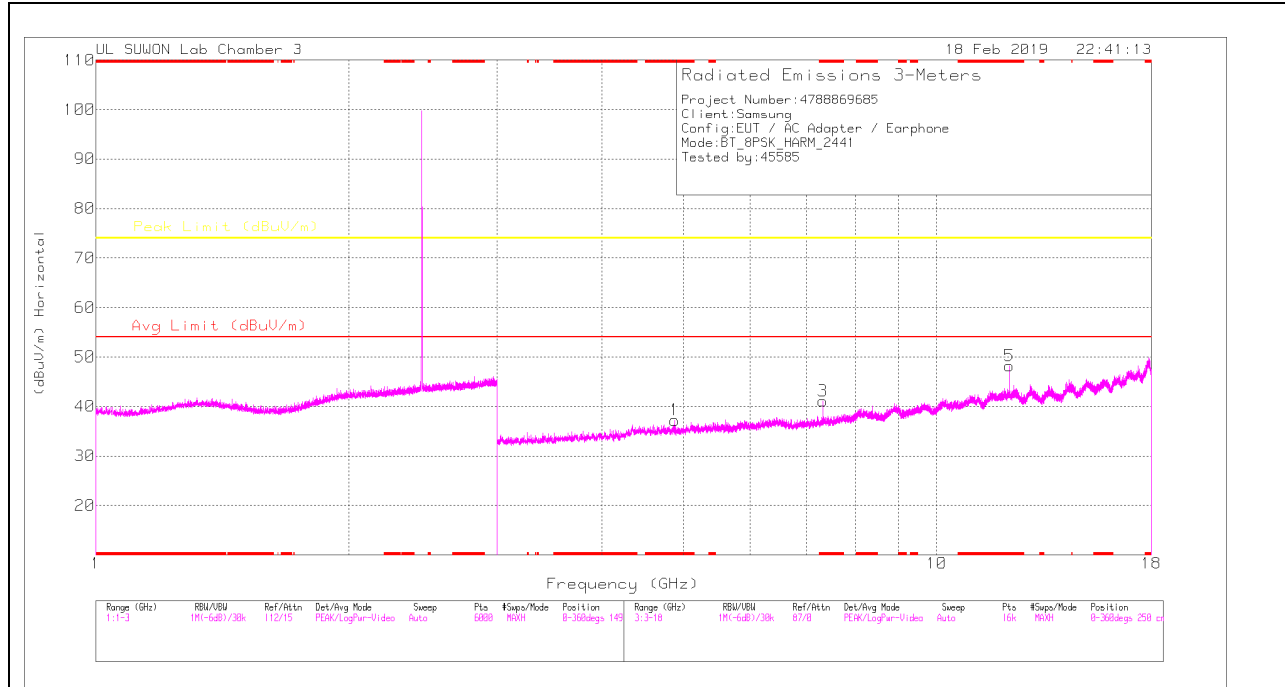

MID CHANNEL VERTICAL

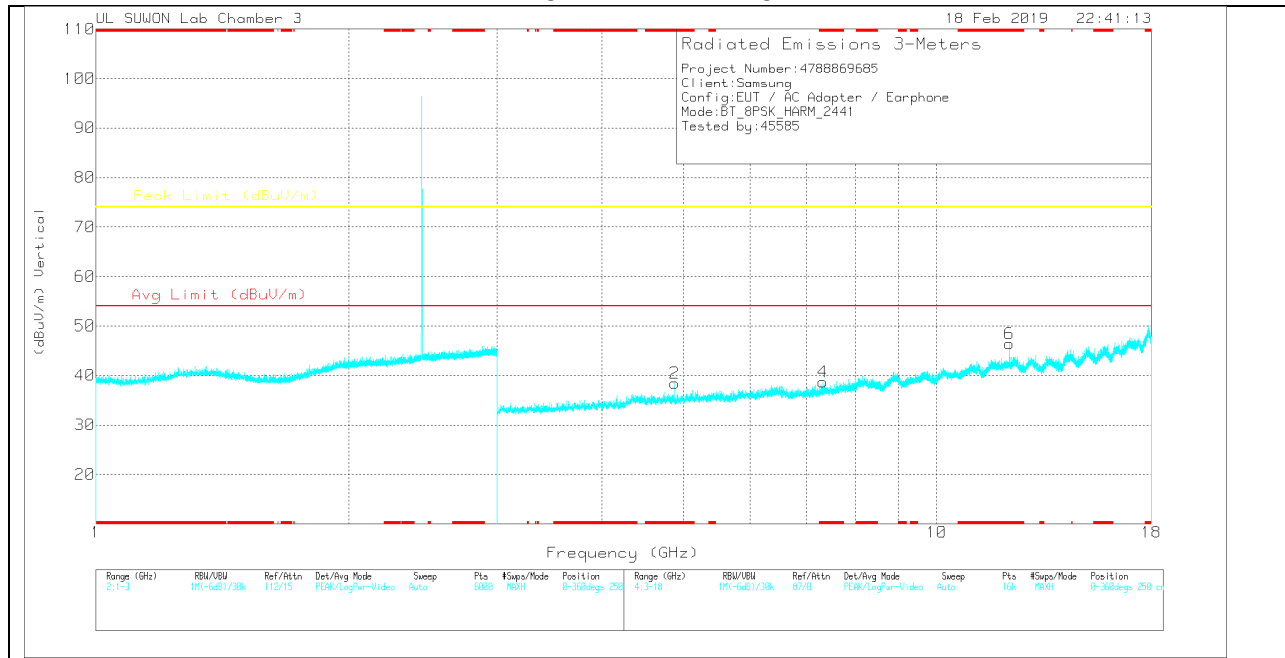

Note: Emission was scanned up to 26GHz; No emissions were detected above the noise floor which was at least 20dB below the specification limit.

MID CHANNEL DATA

Trace Markers

Marker	Frequency (GHz)	Meter Reading (dBuV)	Det	3117_00205959	3GHz_HP[dB]	Corrected Reading (dBuV/m)	Avg Limit (dBuV/m)	Margin (dB)	Peak Limit (dBuV/m)	Margin (dB)	Azimuth (Degs)	Height (cm)	Polarity
1	* 4.882	32.24	PK	34.2	-29.2	37.24	-	-	74	-36.76	0-360	150	H
3	* 7.323	28.87	PK	35.8	-23.6	41.07	-	-	74	-32.93	0-360	150	H
5	* 12.206	28.96	PK	39	-19.7	48.26	-	-	74	-25.74	0-360	150	H
2	* 4.882	33.43	PK	34.2	-29.2	38.43	-	-	74	-35.57	0-360	150	V
4	* 7.323	26.5	PK	35.8	-23.6	38.7	-	-	74	-35.3	0-360	150	V
6	* 12.205	27.29	PK	39	-19.8	46.49	-	-	74	-27.51	0-360	250	V

* - indicates frequency in CFR47 Pt 15 / IC RSS-Restricted Band
 PK – Peak Detector

Radiated Emissions

Frequency (GHz)	Meter Reading (dBuV)	Det	3117_00205959	3GHz_HP[dB]	Corrected Reading (dBuV/m)	Avg Limit (dBuV/m)	Margin (dB)	Peak Limit (dBuV/m)	Margin (dB)	Azimuth (Degs)	Height (cm)	Polarity
* 4.882	41.6	PKFH	34.2	-29.2	46.6	-	-	74	-27.4	132	100	H
* 4.882	31.02	VA1T	34.2	-29.2	36.02	54	-17.98	-	-	132	100	H
* 4.882	40.95	PKFH	34.2	-29.2	45.95	-	-	74	-28.05	216	148	V
* 4.882	30.56	VA1T	34.2	-29.2	35.56	54	-18.44	-	-	216	148	V
* 7.323	36.39	PKFH	35.8	-23.6	48.59	-	-	74	-25.41	143	386	V
* 7.323	24.46	VA1T	35.8	-23.6	36.66	54	-17.34	-	-	143	386	V
* 7.323	38.73	PKFH	35.8	-23.6	50.93	-	-	74	-23.07	187	104	H
* 7.323	28.57	VA1T	35.8	-23.6	40.77	54	-13.23	-	-	187	104	H
* 12.206	40.95	PKFH	39	-19.8	60.15	-	-	74	-13.85	193	100	H
* 12.205	27.96	VA1T	39	-19.8	47.16	54	-6.84	-	-	193	100	H
* 12.206	38.23	PKFH	39	-19.8	57.43	-	-	74	-16.57	191	241	V
* 12.205	25.09	VA1T	39	-19.8	44.29	54	-9.71	-	-	191	241	V

* - indicates frequency in CFR47 Pt 15 / IC RSS-Restricted Band
 PKFH - FHSS: RB=100k/1MHz VB=3 x RB, Peak
 VA1T - FHSS: Linear Voltage Average VB=1/Ton where: Ton is transmit duration

HIGH CHANNEL HORIZONTAL

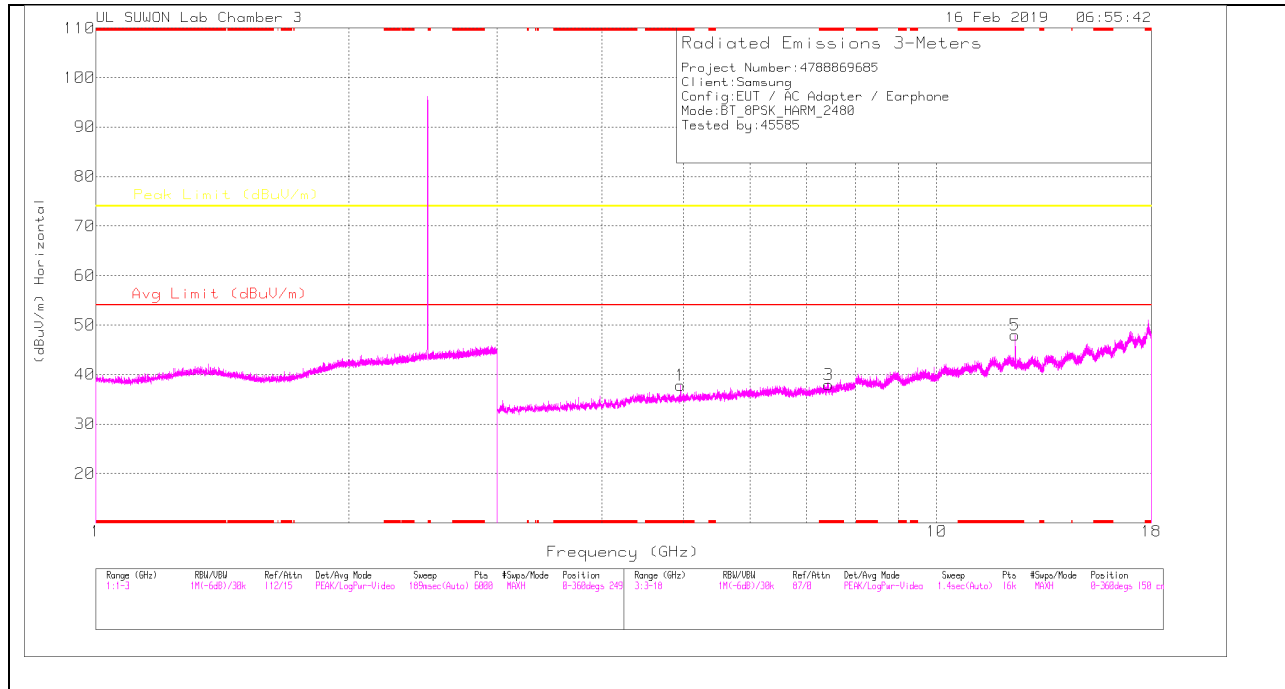

HIGH CHANNEL VERTICAL

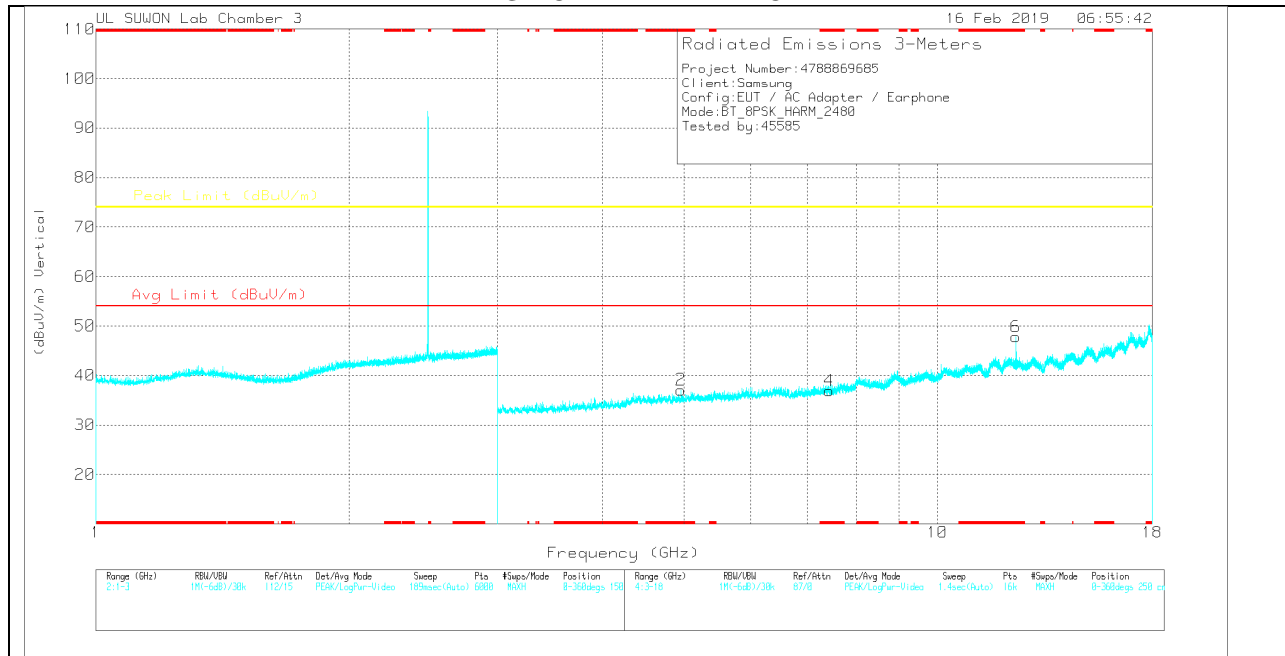

Note: Emission was scanned up to 26GHz; No emissions were detected above the noise floor which was at least 20dB below the specification limit.

HIGH CHANNEL DATA

Trace Markers

Marker	Frequency (GHz)	Meter Reading (dBuV)	Det	3117_00205959	3GHz_HP[dB]	Corrected Reading (dBuV/m)	Avg Limit (dBuV/m)	Margin (dB)	Peak Limit (dBuV/m)	Margin (dB)	Azimuth (Degs)	Height (cm)	Polarity
1	* 4.959	32.56	PK	34.2	-28.9	37.86	-	-	74	-36.14	0-360	150	H
3	* 7.439	25.53	PK	35.8	-23.4	37.93	-	-	74	-36.07	0-360	150	H
5	* 12.401	29.31	PK	38.8	-20.2	47.91	-	-	74	-26.09	0-360	150	H
2	* 4.959	31.81	PK	34.2	-28.9	37.11	-	-	74	-36.89	0-360	150	V
4	* 7.441	24.56	PK	35.8	-23.4	36.96	-	-	74	-37.04	0-360	150	V
6	* 12.4	29.12	PK	38.9	-20.2	47.82	-	-	74	-26.18	0-360	250	V

* - indicates frequency in CFR47 Pt 15 / IC RSS-Restricted Band
 PK – Peak Detector

Radiated Emissions

Frequency (GHz)	Meter Reading (dBuV)	Det	3117_00205959	3GHz_HP[dB]	Corrected Reading (dBuV/m)	Avg Limit (dBuV/m)	Margin (dB)	Peak Limit (dBuV/m)	Margin (dB)	Azimuth (Degs)	Height (cm)	Polarity
* 4.96	40.99	PKFH	34.2	-28.9	46.29	-	-	74	-27.71	199	128	H
* 4.96	30.4	VA1T	34.2	-28.9	35.7	54	-18.3	-	-	199	128	H
* 4.96	40.54	PKFH	34.2	-28.9	45.84	-	-	74	-28.16	200	142	V
* 4.96	31.23	VA1T	34.2	-28.9	36.53	54	-17.47	-	-	200	142	V
* 12.4	38.98	PKFH	38.8	-20.2	57.58	-	-	74	-16.42	94	100	V
* 12.4	27.49	VA1T	38.8	-20.2	46.09	54	-7.91	-	-	94	100	V
* 12.4	43.66	PKFH	38.9	-20.2	62.36	-	-	74	-11.64	182	100	H
* 12.4	32.97	VA1T	38.8	-20.2	51.57	54	-2.43	-	-	182	100	H

* - indicates frequency in CFR47 Pt 15 / IC RSS-Restricted Band
 PKFH - FHSS: RB=100k/1MHz VB=3 x RB, Peak
 VA1T - FHSS: Linear Voltage Average VB=1/Ton where: Ton is transmit duration

11.3. WORST-CASE BELOW 1 GHz

GFSK SPURIOUS EMISSIONS 30 TO 1000 MHz

HORIZONTAL PLOT

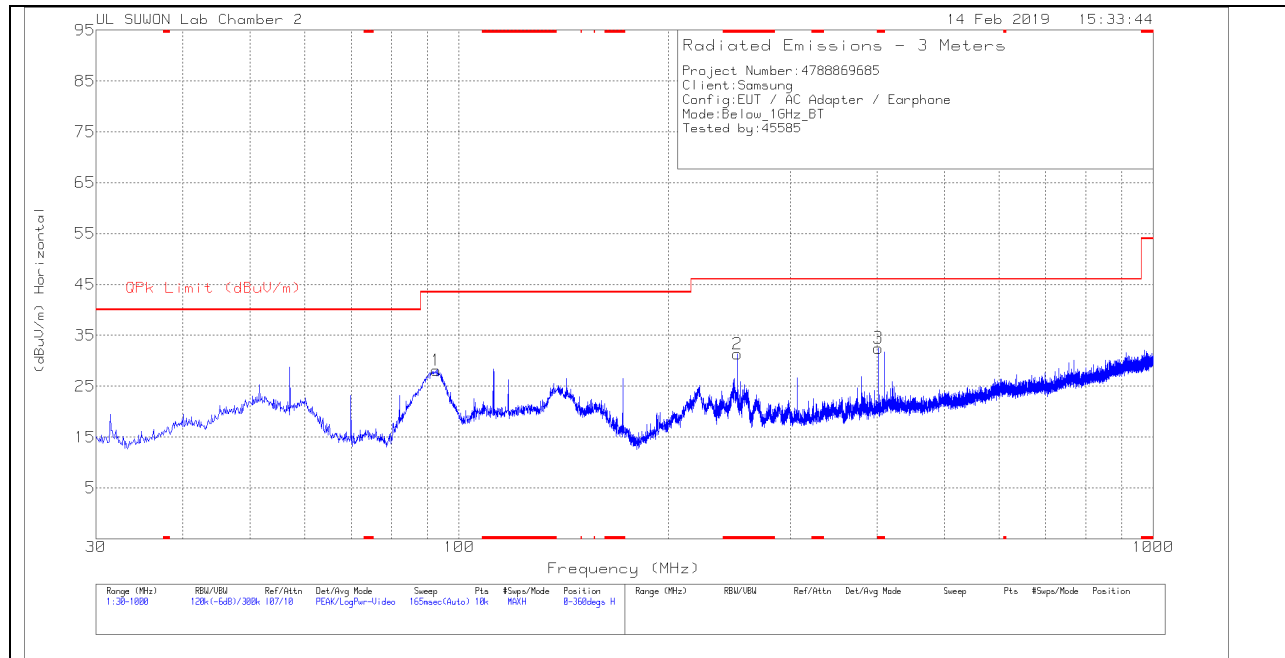

VERTICAL PLOT

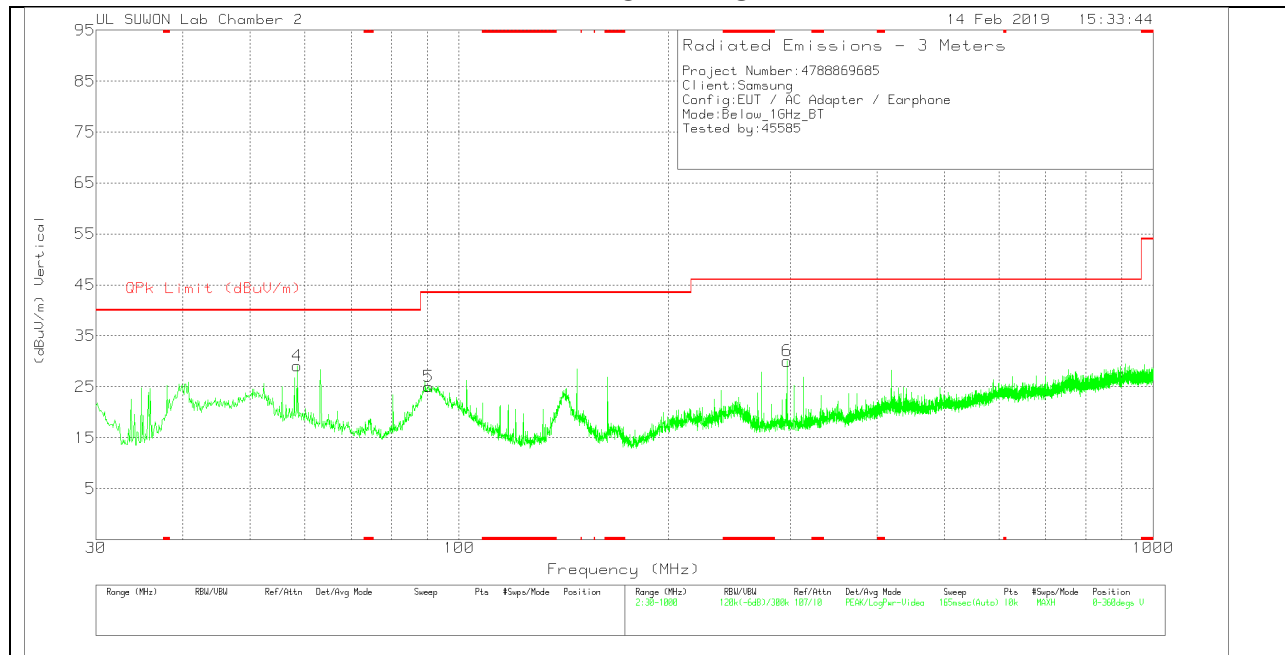

BELOW 1 GHz TABLE

Trace Markers

Marker	Frequency (MHz)	Meter Reading (dBuV)	Det	VULB9163_749	Below_1G[dB]	Corrected Reading (dBuV/m)	QPk Limit (dBuV/m)	Margin (dB)	Azimuth (Degs)	Height (cm)	Polarity
1	92.662	43.07	Pk	16.6	-31.5	28.17	43.52	-15.35	0-360	200	H
2	* 251.645	42.8	Pk	19.1	-30.6	31.3	46.02	-14.72	0-360	100	H
3	* 401.801	41.41	Pk	21.3	-30.2	32.51	46.02	-13.51	0-360	300	H
4	58.421	42	Pk	18.8	-31.7	29.1	40	-10.9	0-360	100	V
5	90.431	40.78	Pk	15.8	-31.5	25.08	43.52	-18.44	0-360	100	V
6	296.653	41.34	Pk	19.2	-30.5	30.04	46.02	-15.98	0-360	100	V

* - indicates frequency in CFR47 Pt 15 / IC RSS-Restricted Band

Pk - Peak detector

12. AC POWER LINE CONDUCTED EMISSIONS

LIMITS

FCC §15.207 (a)

Frequency of Emission (MHz)	Conducted Limit (dBuV)	
	Quasi-peak	Average
0.15-0.5	66 to 56	56 to 46
0.5-5	56	46
5-30	60	50

*Decreases with the logarithm of the frequency.

TEST PROCEDURE

The EUT is placed on a non-conducting table 40 cm from the vertical ground plane and 80 cm above the horizontal ground plane. The EUT is configured in accordance with ANSI C63.10.

The receiver is set to a resolution bandwidth of 9 kHz. Peak detection is used unless otherwise noted as quasi-peak or average.

Line conducted data is recorded for both NEUTRAL and HOT lines.

RESULTS

WORST EMISSIONS

LINE 1 PLOT

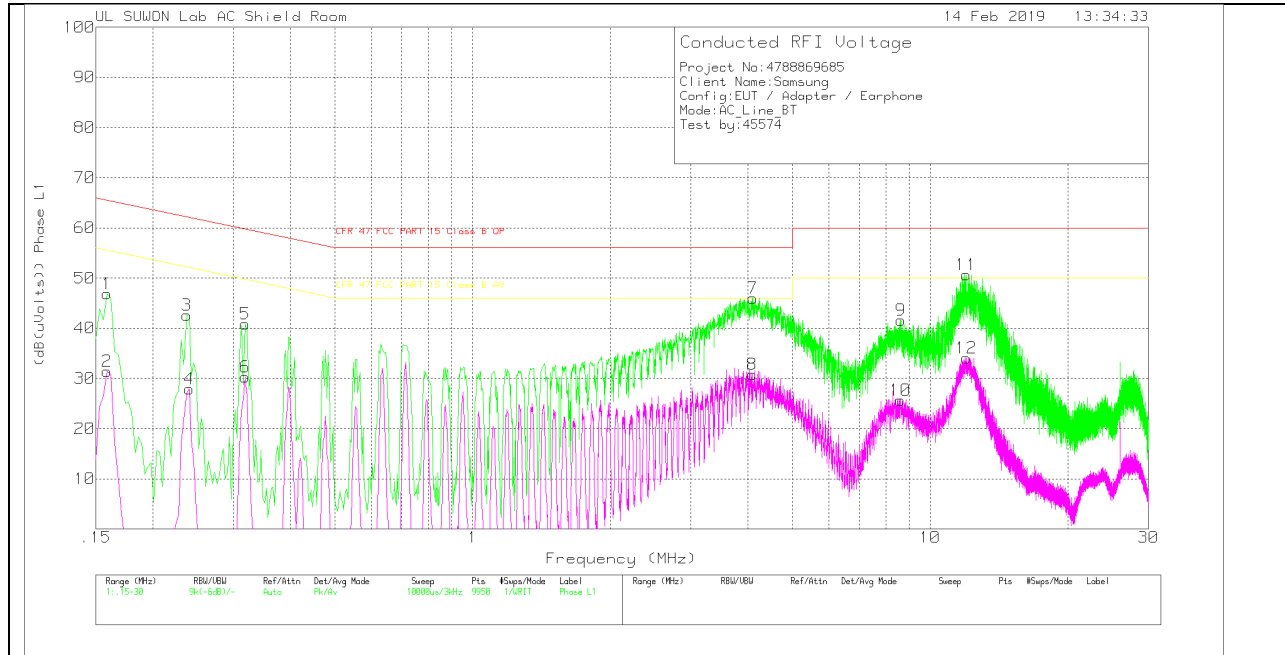

LINE 1 RESULTS

Trace Markers

Range 1: Phase L1 .15 - 30MHz

Marker	Frequency (MHz)	Meter Reading (dBuV)	Det	ENV216_101836_With ex-cord_L1	CABLELOSS(dB)	Corrected Reading (dB(uVolts))	CFR 47 FCC PART 15 Class B QP	Margin (dB)	CFR 47 FCC PART 15 Class B AV	Margin (dB)
1	.159	36.93	Pk	9.9	.1	46.93	65.52	-18.59	-	-
2	.159	21.41	Av	9.9	.1	31.41	-	-	55.52	-24.11
3	.237	32.68	Pk	9.7	.2	42.58	62.2	-19.62	-	-
4	.24	17.99	Av	9.7	.2	27.89	-	-	52.1	-24.21
5	.318	30.83	Pk	9.8	.2	40.83	59.76	-18.93	-	-
6	.318	20.26	Av	9.8	.2	30.26	-	-	49.76	-19.5
7	4.098	35.87	Pk	9.8	.3	45.97	56	-10.03	-	-
8	4.089	20.73	Av	9.8	.3	30.83	-	-	46	-15.17
9	8.628	31.45	Pk	9.9	.3	41.65	60	-18.35	-	-
10	8.607	15.5	Av	9.9	.3	25.7	-	-	50	-24.3
11	11.988	40.2	Pk	10.1	.3	50.6	60	-9.4	-	-
12	11.988	23.65	Av	10.1	.3	34.05	-	-	50	-15.95

Pk - Peak detector

Av - Average detection

Quasi-Peak Emissions

Range 1: Phase L1 .15 - 30MHz

Frequency (MHz)	Meter Reading (dBuV)	Det	ENV216_101836_With ex-cord_L1	CABLELOSS(dB)	Corrected Reading (dB(uVolts))	CFR 47 FCC PART 15 Class B QP	Margin (dB)	CFR 47 FCC PART 15 Class B AV	Margin (dB)
4.09725	30.9	Qp	9.8	.3	41	56	-15	-	-
11.9888	32.55	Qp	10.1	.3	42.95	60	-17.05	-	-

Qp - Quasi-Peak detector

LINE 2 PLOT

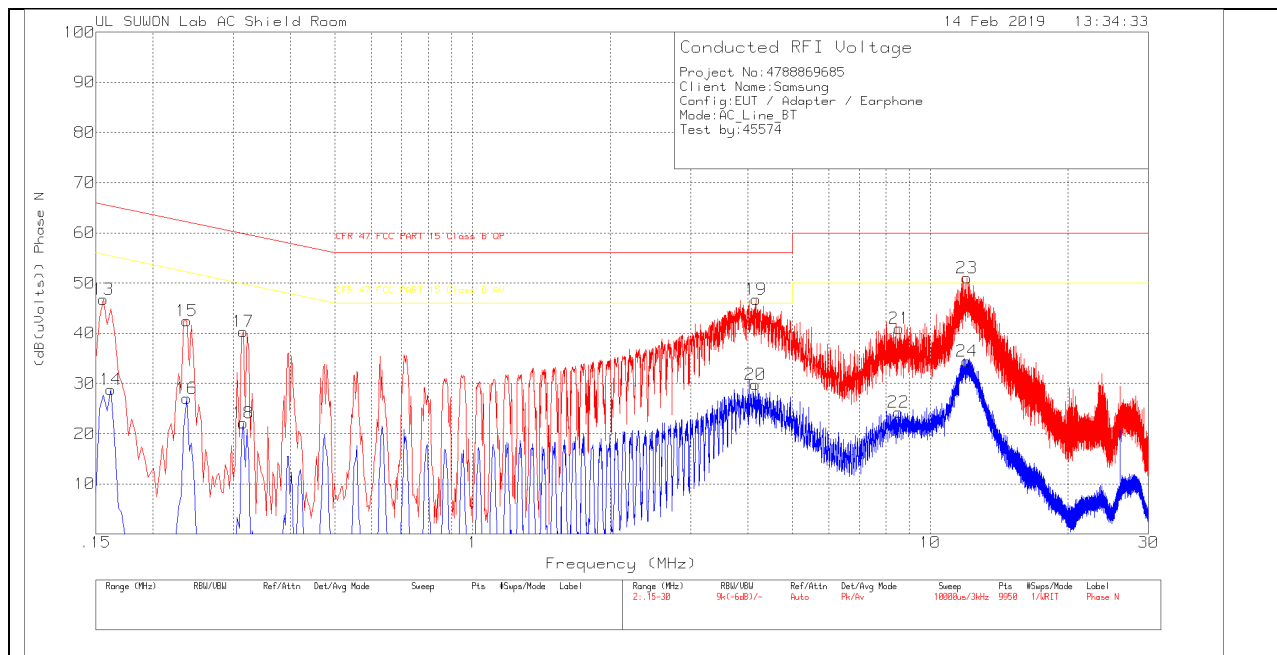

LINE 2 RESULTS

Trace Markers

Range 2: Phase N .15 - 30MHz

Marker	Frequency (MHz)	Meter Reading (dBuV)	Det	ENV216_10183 6_With ex-cord_N	CABLELOSS(dB)	Corrected Reading (dB(uVolts))	CFR 47 FCC PART 15 Class B QP	Margin (dB)	CFR 47 FCC PART 15 Class B AV	Margin (dB)
13	.156	36.81	Pk	9.8	.1	46.71	65.67	-18.96	-	-
14	.162	18.75	Av	9.9	.1	28.75	-	-	55.36	-26.61
15	.237	32.61	Pk	9.7	.2	42.51	62.2	-19.69	-	-
16	.237	17.18	Av	9.7	.2	27.08	-	-	52.2	-25.12
17	.315	30.32	Pk	9.8	.2	40.32	59.84	-19.52	-	-
18	.315	12.14	Av	9.8	.2	22.14	-	-	49.84	-27.7
19	4.161	36.68	Pk	9.8	.3	46.78	56	-9.22	-	-
20	4.143	19.72	Av	9.8	.3	29.82	-	-	46	-16.18
21	8.565	30.73	Pk	9.9	.3	40.93	60	-19.07	-	-
22	8.523	14.05	Av	9.9	.3	24.25	-	-	50	-25.75
23	12.03	40.59	Pk	10.1	.3	50.99	60	-9.01	-	-
24	12.036	24.05	Av	10.1	.3	34.45	-	-	50	-15.55

Pk - Peak detector

Av - Average detection

Quasi-Peak Emissions

Range 2: Phase N .15 - 30MHz

Frequency (MHz)	Meter Reading (dBuV)	Det	ENV216_101836 _With ex-cord_N	CABLELOSS(dB)	Corrected Reading (dB(uVolts))	CFR 47 FCC PART 15 Class B QP	Margin (dB)	CFR 47 FCC PART 15 Class B AV	Margin (dB)
4.16175	30.42	Qp	9.8	.3	40.52	56	-15.48	-	-
12.0308	32.16	Qp	10.1	.3	42.56	60	-17.44	-	-

Qp - Quasi-Peak detector