



HAC VOLUME CONTROL TEST REPORT

**FCC 47 CFR § 20.19
ANSI C63.19-2019
ANSI/TIA-5050 2018**

For

GSM/WCDMA/LTE/5G NR Phone + BT/BLE, DTS/UNII a/b/g/n/ac and NFC

MODEL NUMBER : SM-A166U, SM-A166U1, SM-S166V

FCC ID: A3LSMA166U

REPORT NUMBER: S-4791440365-S4V1

ISSUE DATE: 2024-10-07

Prepared for

**SAMSUNG ELECTRONICS CO., LTD.
129 SAMSUNG-RO, YEONGTONG-GU, SUWON-SI,
GYEONGGI-DO, 16677, KOREA**

Prepared by

UL Korea, Ltd.

26th floor, 152, Teheran-ro, Gangnam-gu Seoul, 06236, Korea

**Suwon Test Site: UL Korea, Ltd. Suwon Laboratory
218 Maeyeong-ro, Yeongtong-gu,
Suwon-si, Gyeonggi-do, 16675, Korea
TEL: (031) 337-9902
FAX: (031) 213-5433**



Testing Laboratory

TL-637

Revision History

Rev.	Date	Revisions	Revised By
V1	2024-10-07	Initial Issue	-

Table of Contents



1. Attestation of Test Results	4
2. Test Methodology	5
3. Facilities and Accreditation	5
4. Calibration and Uncertainty	5
4.1. <i>Measuring Instrument Calibration</i>	5
4.2. <i>Measurement Uncertainty</i>	6
4.3. <i>Decision Rule</i>	6
5. Test Procedures for all Technologies	7
5.1. <i>General Procedures ANSI/TIA-5050 2018, Section 5</i>	7
5.2. <i>Receive Volume Control Performance</i>	7
5.3. <i>Receive Distortion and Noise Performance (PN-SDNR)</i>	8
5.4. <i>Receive Acoustic Frequency Response Performance</i>	8
6. Base Station Simulator – software/firmware	9
6.1. <i>VoLTE</i>	9
6.2. <i>VoNR</i>	9
6.3. <i>VoWi-Fi</i>	9
7. Receive Volume Control Requirements	10
7.1. <i>Receive Volume Control</i>	10
7.2. <i>Receive Distortion and Noise</i>	10
7.3. <i>Receive Acoustic Frequency Response</i>	10
7.4. <i>HAC Compliance under Waiver DA 23-914</i>	12
8. Device Under Test	13
8.1. <i>Air Interfaces and Operating Mode</i>	13
9. HAC (Volume Control) Test Results	14
9.1. <i>CMRS Narrow-band/Wide-band Codec Investigation</i>	14
9.2. <i>Antenna and Air Interface Investigation for VoLTE/VoNR/VoWiFi</i>	15
9.3. <i>Other Voice Codecs Investigation for GSM/WCDMA/VoLTE/VoNR/VoWiFi</i>	25
9.4. <i>HAC (Volume Control) Test Results</i>	29
9.5. <i>Worst Case Volume Control Test Plot</i>	31
Appendix	33
4791440365-S4 Appendix A_Setup Photo	33
4791440365-S4 Appendix B_Test Plots	33

1. Attestation of Test Results

Applicant Name	SAMSUNG ELECTRONICS CO.,LTD.
FCC ID	A3LSMA166U
Model Name	SM-A166U, SM-A166U1, SM-S166V
Applicable Standards	FCC 47 CFR § 20.19 ANSI C63.19-2019 ANSI/TIA-5050 2018
Conversational Gain	12.17 dB with hearing aid and 16.42 dB without hearing aid
Date Tested	2024-09-19 to 2024-10-02
Test Results	Pass

UL Korea, Ltd. tested the above equipment in accordance with the requirements set forth in the above standards. All indications of Pass/Fail in this report are opinions expressed by UL Korea, Ltd. based on interpretations and/or observations of test results. Measurement Uncertainties were not taken into account and are published for informational purposes only. The test results show that the equipment tested is capable of demonstrating compliance with the requirements as documented in this report.

Note: The results documented in this report apply only to the tested sample, under the conditions and modes of operation as described herein. This document may not be altered or revised in any way unless done so by UL Korea, Ltd. and all revisions are duly noted in the revisions section. Any alteration of this document not carried out by UL Korea, Ltd. will constitute fraud and shall nullify the document. This report must not be used by the client to claim product certification, approval, or endorsement by IAS, any agency of the Federal Government, or any agency of any government.

Approved & Released By: 	Prepared By: 
Justin Park Operations Leader UL Korea, Ltd. Suwon Laboratory	Gyurim Lee Laboratory Engineer UL Korea, Ltd. Suwon Laboratory

2. Test Methodology

The tests documented in this report were performed in accordance with FCC 47 CFR § 20.19, ANSI C63.19-2019 and ANSI/TIA-5050 2018 Communications Products – Receive Volume Control Requirements for Wireless (Mobile) Devices and FCC published KDB procedures.

KDB 285076 D01 HAC Guidance v06r04
 KDB 285076 D03 HAC FAQ v01r06
 KDB 285076 D04 Volume Control v02
 KDB 285076 D05 CG Interim Waiver DA 23-914 v01
 TCB workshop updates

3. Facilities and Accreditation

The test sites and measurement facilities used to collect data are located at

Suwon
Volume Control Room

UL Korea, Ltd. is accredited by IAS, Laboratory Code TL-637.

The full scope of accreditation can be viewed at <https://www.iasonline.org/wp-content/uploads/2017/05/TL-637-cert-New.pdf>

4. Calibration and Uncertainty

4.1. Measuring Instrument Calibration

The measuring equipment used to perform the tests documented in this report has been calibrated in accordance with the manufacturers' recommendations and is traceable to recognized national standards.

Name of Equipment	Manufacturer	Type/Model	Serial No.	Cal. Due Date
Head and Torso Simulator incl Right Ear Simulator and Handset Positioner	Brüel&Kjaer	-4128-C-001-	3285404	2025-06-19
Single Channel, Universal Microphone Conditioning Amplifier	Brüel&Kjaer	-1708---	100426	2025-06-14
Sound Calibrator, Class 1 and LS, 94 and 114 dB, 1 kHz.	Brüel&Kjaer	-4231---	3026386	2025-06-14
Production Test USB-DAQ 8/2-ch.	Brüel&Kjaer	-3670-A-082-	3670-000120	2025-07-21
Sound Level Meter	Brüel&Kjaer	2250 Light	3031250	2025-06-14
Communications Tester	R & S	CMW500	150314	2025-07-24
Wireless Test Platform	Keysight	E7515B	MY57510596	2025-07-30
Audio Analyzer	AGILENT	U8903A	MY61170007	2025-07-30
Thermometer	LUTRON	MHB-382SD	AK.12121	2025-07-26

4.2. Measurement Uncertainty

Measurement Uncertainty for Volume Control Measurement

a	c	d	e f(d,k)	f	k	h = cxf/e
Uncertainty component	Tol.(±%)	Prob. Dist.	Div.	ci	vi	ui (± %)
Measurement System - Input channels of Audio Interface (Production Test USB DAQ Type 3670)						
Overall Frequency Response (re. 1 kHz)	0.02	Rectangular	1.732	1	∞	0.01
Measurement System - Output channels of Audio Interface (Production Test USB DAQ Type 3670)						
Measurement System - Pre-Amplifier (Signal Conditioner Type 1708)						
Gain Tolerance 10 Hz 100 kHz	0.01	Rectangular	1.732	1	∞	0.01
Measurement System - Ear-Simulator (Right Ear Simulator Type 4158-C)						
Typical Sensitivity	0.19	Rectangular	1.732	1	∞	0.11
Test Sample Related						
Repeatability Test(Conversational Gain)	5.76	Normal	1	1	40	5.76
Repeatability Test(Acoustic Frequency Response)	1.54	Normal	1	1	40	1.54
Repeatability Test(Distortion)	11.85	Normal	1	1	40	11.85
Combined Standard Uncertainty U_c(y) =			Expanded Uncertainty			
Conversational Gain	5.76	Conversational Gain				11.53
Acoustic Frequency Response	1.55	Acoustic Frequency Response				3.09
Distortion	11.85	Distortion				23.71
Notes for table						
1. Ci - is te sensitivity coefficient						
2. Expanded Std. Uncertainty on Pow er, Coverage Factor = 2, > 95% Confidence						

4.3. Decision Rule

Decision rule for statement(s) of conformity is based on Procedure 2, Clause 4.4.3 in IEC Guide 115:2021.

5. Test Procedures for all Technologies

5.1. General Procedures ANSI/TIA-5050 2018, Section 5

The following requirements shall be met for at least one volume control setting for the narrowband transmission mode (if supported) and the wideband transmission mode (if supported).

Quiet room is a room with background noise no greater than 40 dBA.

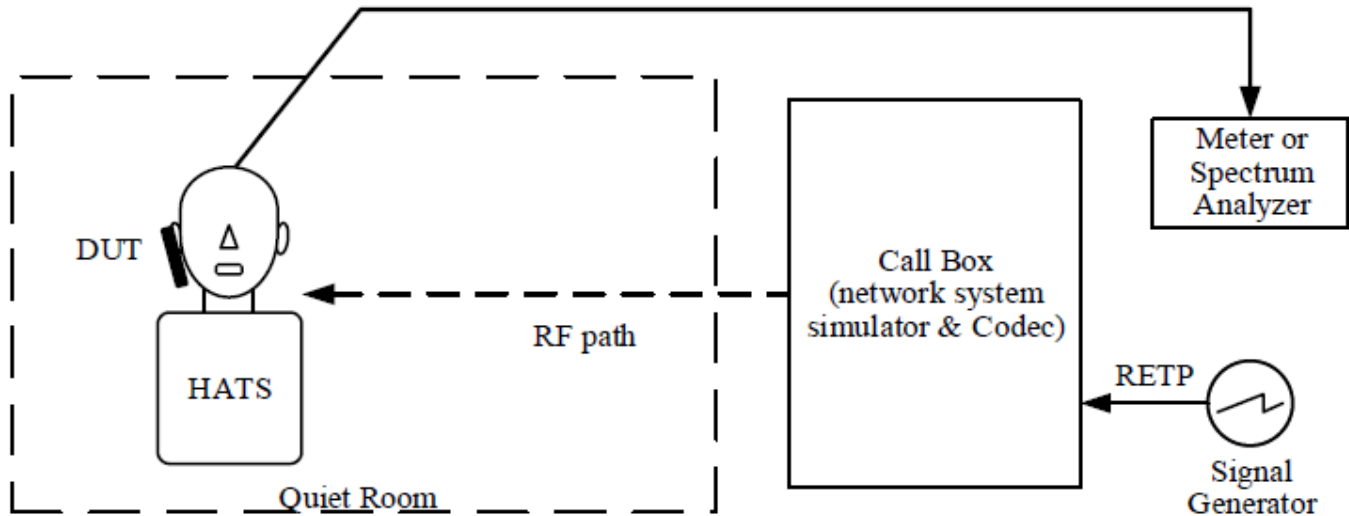

Figure 1. Test Arrangement

5.2. Receive Volume Control Performance

Method of Measurement

- 1) Configure the DUT with a mounting force of 8N and test equipment as shown in Figure 1 in an active call state with the applicable codec for the transmission mode under test.
- 2) Set the DUT volume control to the maximum setting.
- 3) If the DUT has an adjustable tone control feature, a tone control setting that meets the frequency response requirements in section 5.3.1 shall be used.
- 4) Apply the real speech test signal at a level of -20 dBm0 at the RETP and measure the acoustic output at the Drum Reference Point (DRP) over one complete sequence of the test signal.
- 5) Translate the measurement made at the DRP to the Free Field (FF) using the translation data in Annex B.
- 6) Over the applicable frequency band, determine the ASL in dBSPL for the resulting sound pressure level in accordance with Method B of ITU-T Recommendation P.56:
 - a. Narrowband 100 Hz through 4000 Hz.
 - b. Wideband 100 Hz through 7720 Hz.
- 7) Calculate the Conversational Gain by subtracting 70 dB from the measured dBSPL.
[Conversational Gain = (Measured dBSPL Level – 70 dBSPL) dB]
- 8) Measure the output distortion per clause 5.2. If a distortion failure occurs at the maximum volume control setting, reduce the volume control setting and repeat the measurement to determine if a setting can be found for which the conversational gain requirement is met without a distortion failure.
- 9) Repeat steps 2-8 with a mounting force of 2N.

5.3. Receive Distortion and Noise Performance (PN-SDNR)

Receive distortion is specified in terms of Signal-to-Distortion-and-Noise Ratio (SDNR) using a Pulsed Noise (PN) test signal. PN-SDNR is the ratio of the signal power to the total A-weighted distortion and noise power of the signal output expressed in dB. It is measured using a pulsed 1/3 octave pink noise input signal as described in TIA-5050 2018 Annex A.

Method of Measurement

- 1) Configure the DUT with a mounting force of 8N and test equipment as shown in Figure 1 in an active call state with the applicable codec for the transmission mode under test with the volume control at the setting determined in 5.1.1.
- 2) Receive distortion and noise is measured using the PN-SDNR procedure as described in Annex A.
- 3) To ensure DUT activation, apply the real speech test signal at a level of -20 dBm0 followed immediately by the initial 1/3 octave center frequency PN test signal in Table A.1 based on the narrowband or wideband operating mode. Measure the acoustic output at the DRP over the complete sequence of the PN test signal.
- 4) Translate the measurement made at the DRP to the FF using the translation data in Annex B.
- 5) Calculate the acoustic output unweighted total signal power of the stimulus measurement band as described in A.2.
- 6) Calculate the notched A-weighting distortion and noise components as described in A.3.
- 7) Calculate the ratio of the signal power to the total A-weighted distortion and noise power using Eq A-1.
- 8) Repeat for each of the remaining 1/3 octave center frequencies in Table A.1 based on the narrowband or wideband operating mode.

Repeat steps 2-8 with a mounting force of 2N.

5.4. Receive Acoustic Frequency Response Performance

For the volume control settings determined in 5.1.1 with a mounting force of 8N and 2N, the receive frequency response shall be measured at the DRP in 1/12 octave bands. After translation to the FF or DF, it shall fall between the applicable upper and lower limits.

The exact limit values at any 1/12 octave band center frequency falling between two consecutive points specified in the table may be calculated using the formula given in equation below:

$$X_f = X_1 + (X_2 - X_1) * \left(\frac{\log_{10} f - \log_{10} f_1}{\log_{10} f_2 - \log_{10} f_1} \right)$$

Method of Measurement

- 1) Configure the DUT with a mounting force of 8N and test equipment as shown in Figure 1 in an active call state with the applicable codec for the transmission mode under test with the volume control at the setting determined in 5.1.1.
- 2) If the DUT has an adjustable tone control feature the initial measurement is to be performed with the default tone control setting.
- 3) Apply the real speech test signal with a level of -20 dBm0 at the RETP.
- 4) Capture the frequency spectrum at the DRP of the HATS using real-time analysis with 1/12 octave bands over the frequency range from 100 Hz to 4000 Hz for narrowband measurements, or over the frequency range from 100 Hz to 8000 Hz for wideband measurements, averaged over the entire duration of the test signal.
- 5) Transform the DRP frequency spectrum measurement to the FF or DF (see Annex B).
- 6) Divide the 1/12 octave measurement data by the 1/12 octave frequency spectrum of the test signal at the RETP and present the measurement in terms of dB(Pa/V).
- 7) Apply the applicable frequency response limits to determine compliance.
- 8) If the default tone control setting does not meet the requirement, repeat the above steps for other tone control settings to determine a tone control setting that meets the requirements.
- 9) Repeat with a mounting force of 2N.

6. Base Station Simulator – software/firmware

6.1. VoLTE

Refer to the below software/firmware License list for measurement VoLTE.

Firmware	License Keys	Software Name (CMW500)
V3.7.70 for LTE	KS500	LTE FDD R8 SIG BASIC
	KS550	LTE TDD R8 SIG BASIC
V3.7.20 for Audio	KA100	IP APPL ENABLING IPv4
	KA150	IP APPL ENABLING IPv4
	KAA20	IP APPL IMS BASIC
	KM050	DATA APPL MEAS
	KS104	EVS SPEECH CODEC

6.2. VoNR

Refer to the below software/firmware License list for measurement VoNR.

License Option	Software Name (Keysight E7515B)
C8700201A	IMS-SIP Emulation
C87350P1A	5G NR IP data

6.3. VoWi-Fi

Refer to the below software/firmware License list for measurement VoWi-Fi.

Firmware	License Keys	Software Name (CMW500)
V3.7.50 for WLAN	KS650	WLAN A/B/G SIG BASIC
	KS651	WLAN N SIG BASIC
	KS656	WLAN IEEE 802.11ac
	KS657	WLAN IEEE 802.11ax
V3.7.20 for Audio	KA100	IP APPL ENABLING IPv4
	KA150	IP APPL ENABLING IPv6
	KAA20	IP APPL IMS BASIC
	KM050	DATA APPL MEAS
	KS104	EVS SPEECH CODEC

7. Receive Volume Control Requirements

7.1. Receive Volume Control

1. With a mounting force of 8N, the DUT shall have at least one volume control setting that will produce a conversational gain of ≥ 18 dB with the output distortion and the frequency response meeting the requirements in clause 5.2.1 & 5.3.1 respectively.

2. With a mounting force of 2N, the DUT shall have at least one volume control setting that will produce a conversational gain of ≥ 6 dB with the output distortion and the frequency response meeting the requirements in clause 5.2.1 & 5.3.1 respectively.

7.2. Receive Distortion and Noise

With a mounting force of 8N and 2N, the ratio of the stimulus signal power to the 100 Hz to 8000 Hz total A-weighted distortion and noise power shall be ≥ 20 dB when tested over the range of 1/3 octave band center frequencies.

7.3. Receive Acoustic Frequency Response

The results for each 1/12 octave band measurement are to be evaluated against the upper and lower limit values only at the center frequency point for that band (i.e., not the entire width of the band). For graphical purposes, the individual 1/12 octave band measurement results are plotted as points on a linear dB scale (y-axis) versus the band's center frequency on a logarithmic frequency scale (x-axis). The frequency response limits are floating or "best fit" (i.e., the maximum and minimum deviations from the upper and lower limits should be equidistant from those limits).

1. Narrowband: The 1/12 octave band frequency response after translation to the FF or DF shall fall between the upper and lower limits given in Table 1 and shown in Figure 2.

Table 1 – Narrowband Receive Frequency Response Limits

Lower Limit Frequency (Hz)	Lower Limit (dB)	Upper Limit Frequency (Hz)	Upper Limit (dB)
300	-6	100	+6
3400	-6	4000	+6

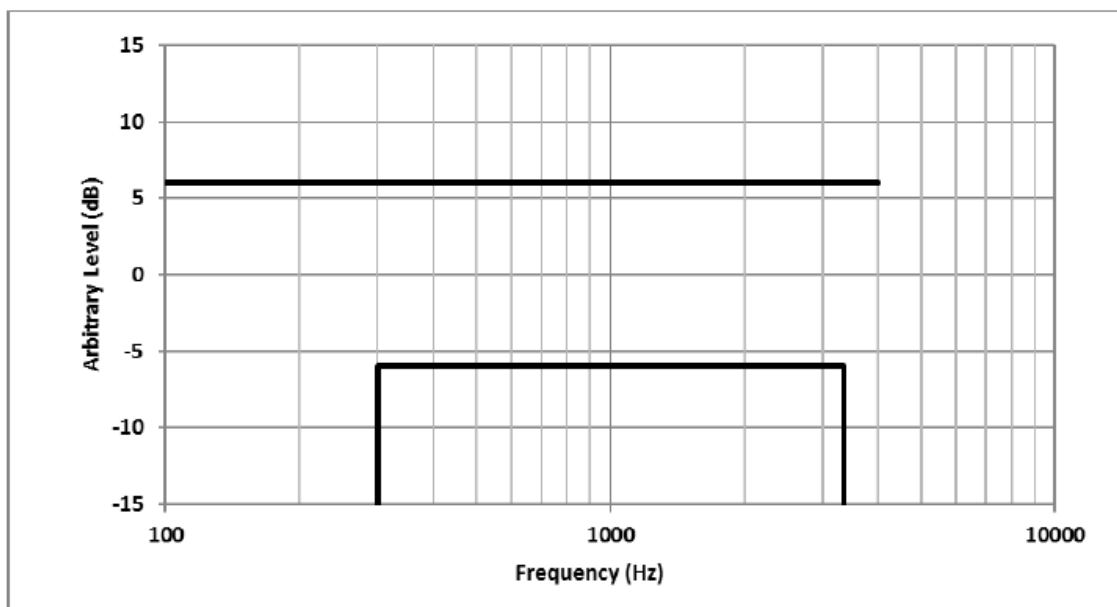

Figure 2 – Narrowband Receive Frequency Response Limits

- 2. Wideband: The 1/12 octave band frequency response after translation to the FF or DF shall fall between the upper and lower limits given in Table 2 and shown in Figure 3.

Table 2 – Wideband Receive Frequency Response Limits

Lower Limit Frequency (Hz)	Lower Limit (dB)	Upper Limit Frequency (Hz)	Upper Limit (dB)
200	-10	100	+6
300	-6	1000	+6
5000	-6	2000	+8
6300	-12	8000	+8

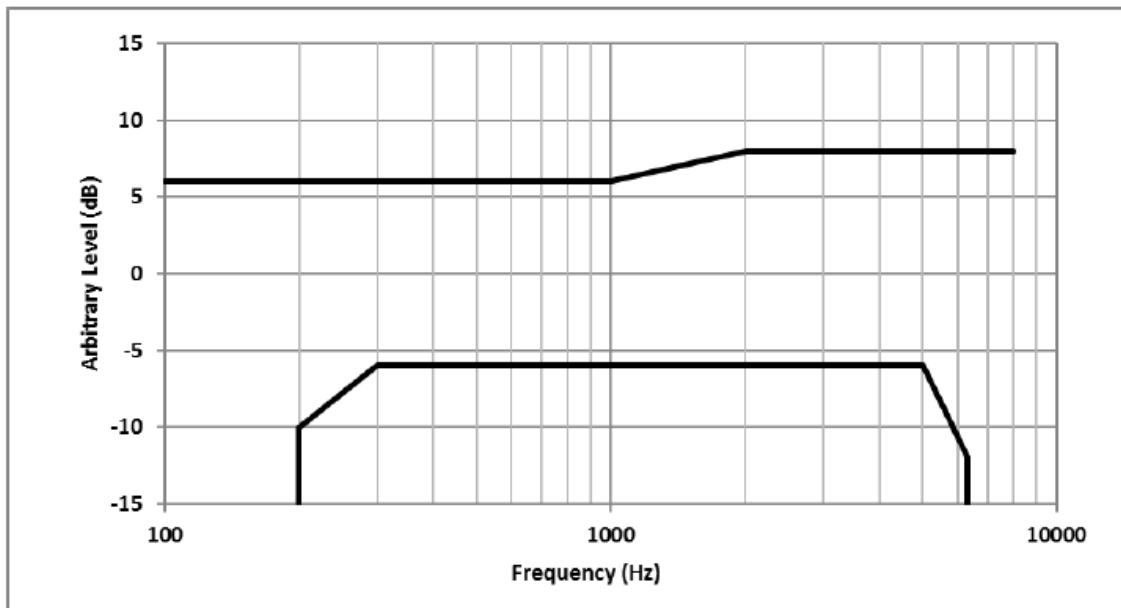

Figure 3 – Wideband Receive Frequency Response Limits

7.4. HAC Compliance under Waiver DA 23-914

The following technical testing requirements for the conversational gain, distortion, and frequency response tests that amends KDB 285076 D04 Volume Control under the conditions of the limited-term waiver DA 23-914.

- a. Under the waiver, only CMRS narrowband and CMRS wideband voice codecs are required to comply with the volume control requirements of the TIA 5050-2018 Volume Control Standard as amended as follows:
 1. For the 2N mounting force test, one narrowband and one wideband voice codec embedded with the handset must pass with at least one volume control setting with a conversational gain of ≥ 6 dB for all voice services, bands of operation and air interfaces over which it operates using one codec bit rate of the applicant's choosing.
 2. For the 8N mounting force test, one narrowband and one wideband voice codec embedded with the handset must pass with at least one volume control setting with a conversational gain of ≥ 6 dB for all voice services, bands of operation and air interfaces over which they operate but is not required to meet or exceed the full 18 dB of conversational gain specified in section 5.1.1 of the TIA 5050 Volume Control Standard using one codec bit rate of the applicant's choosing.
- b. For all other narrowband and wideband codecs not evaluated in **a.** above, TIA 5050-2018 Receive Distortion and Noise Performance and Receive Acoustic Frequency Response Performance evaluations are not required; however, these codecs shall be assessed for conversational gain and documented in the test report at the 2N and 8N levels with a gain of ≥ 6 dB for all voice services, bands of operation and air interfaces over which they operate. The handset volume setting used to comply with **a.** shall be used for these other CMRS codec evaluations.
- c. Any other codec for voice services embedded in the handset, not identified in **a.** and **b.** above, is not required to comply or demonstrate in the test reports for conversational gain.

8. Device Under Test

Normal operation	Held to head
Back Cover	The Back Cover is not removable
Test sample information	<p style="text-align: center;">S/N R3CX808NE0E</p> <p style="text-align: center;">Notes Volume Control Test</p>

8.1. Air Interfaces and Operating Mode

Air Interface	Bands (MHz)	Type	Volume Control Tested	Simultaneous Transmitter	OTT Testing Required? Name of Voice Service	Audio Codecs Evaluated
GSM	850	VO	Yes ² FR V1, FR V2, HR V1	Wi-Fi and BT	CMRS	FR V1, FR V2, HR V1
	1900					
	GPRS/EDGE	VD	No ³	Wi-Fi and BT	No ³ Google Meet	OPUS
W-CDMA (UMTS)	850 (V)	VO	Yes ² AMR-NB, AMR-WB	Wi-Fi and BT	CMRS	AMR-NB & AMR-WB
	1750 (IV)					
	1900 (II)					
	HSPA	VD	No ³	Wi-Fi and BT	No ³ Google Meet	OPUS
LTE - FDD	680 (B71)	VD	Yes ¹ EVS-nb 24.4 kbps EVS-w b 24.4 kbps	NR, Wi-Fi and BT	VoLTE No ³ Google Meet	AMR-NB, AMR-WB, EVS and OPUS
	700 (B12)					
	780 (B13)					
	790 (B14)					
	850 (B5/26)					
	1700 (B4/66)					
	1900 (B2/25)					
	2300 (B30)					
	2600 (B7)					
LTE - TDD	2600 (B38/41)	VD	No ³ EVS-sw b, OPUS	NR, Wi-Fi and BT	VoLTE No ³ Google Meet	AMR-NB, AMR-WB, EVS and OPUS
	3600 (B48)					
NR - FDD	680 (n71)	VD	Yes ¹ EVS-nb 24.4 kbps EVS-w b 24.4 kbps	LTE, Wi-Fi and BT	VoNR No ³ Google Meet	AMR-NB, AMR-WB, EVS and OPUS
	850 (n5)					
	1700 (n66)					
	1700 (n70)					
	1900 (n2/25)					
	2300 (n30)					
NR - TDD	2600 (n41)	VD	No ³ EVS-sw b, OPUS	LTE, Wi-Fi and BT	VoNR No ³ Google Meet	AMR-NB, AMR-WB, EVS and OPUS
	3600 (n48)					
	3500 (n77 DoD/n78 DoD)					
	3700 (n77/n78)					
Wi-Fi	2450	VD	Yes ¹ EVS-nb 24.4 kbps EVS-w b 24.4 kbps	WWAN	VoWiFi No ³ Google Meet	AMR-NB, AMR-WB, EVS and OPUS
	5200 (U-NII-1)					
	5300 (U-NII-2A)					
	5500 (U-NII-2C)					
	5800 (U-NII-3)					
	5800 (U-NII-3)	No ³ EVS-sw b, OPUS	WWAN and BT			
BT	2450	DT	N/A	WWAN and U-NII	N/A	N/A

Type	Note:
VO: Legacy Cellular Voice Service	1. Tested Conversational Gain, Frequency Response, PN-SDNR.
DT: Digital Transport only (no voice)	2. Tested only Conversational Gain. (Waiver DA 23-914)
VD: IP Voice Service over Digital Transport	3. Not required to comply with Volume Control standard. (Waiver DA 23-914)
CMRS: Commercial Mobile Radio Service	
BT: Bluetooth	

9. HAC (Volume Control) Test Results

CMRS NB/WB Codex and bitrate; EVS-nb 24.4 kbps and EVS-wb 24.4 kbps were chosen by applicant. All Volume Control measurements were performed with volume max-1 level.

9.1. CMRS Narrow-band/Wide-band Codec Investigation

An investigation was performed to determine the worst-case CMRS NB/WB Codec per technology. All subsequent measurements were determined by this investigation.

2N Mounting Force

Codec (NB or WB)	Volume Control Level	Mode / Band	Antenna	Voice Codec / Codec bitrate (kbps)	Channel and Frequency	Bandwidth	Waveform / Modulation	RB (Allocation/ Offset)	Volume Control Results				
									2N				
									Noise (LAF_MAX) (dBA)	Conversational Gain (dB)	Frequency Response Margin (dB)		FN-SDNR margin (dB)
		FF	DF										
WB	Max - 1	LTE Band 66	Ant.A	EVS-WB 24.4 kbit/s	132322 1745 MHz	20 MHz	QPSK	1/0	26.1	12.46	3.25	2.30	5.98
NB	Max - 1	LTE Band 66	Ant.A	EVS-NB 24.4 kbit/s	132322 1745 MHz	20 MHz	QPSK	1/0	26.1	15.48	2.52	1.56	9.01
WB	Max - 1	LTE Band 41 PC2	Ant.A	EVS-WB 24.4 kbit/s	40620 2593 MHz	20 MHz	QPSK	1/0	26.4	12.17	3.17	2.10	5.47
NB	Max - 1	LTE Band 41 PC2	Ant.A	EVS-NB 24.4 kbit/s	40620 2593 MHz	20 MHz	QPSK	1/0	26.4	15.21	2.28	1.45	7.52
WB	Max - 1	NR Band n66	Ant.A	EVS-WB 24.4 kbit/s	349000 1745.00 MHz	40 MHz	DFT-s-OFDM QPSK	1/1	27.1	12.64	3.42	3.10	8.31
NB	Max - 1	NR Band n66	Ant.A	EVS-NB 24.4 kbit/s	349000 1745.00 MHz	40 MHz	DFT-s-OFDM QPSK	1/1	27.1	15.14	2.71	1.93	9.72
WB	Max - 1	NR Band n77 HPUE	Ant.E	EVS-WB 24.4 kbit/s	650000 3750 MHz	100 MHz	DFT-s-OFDM QPSK	1/1	26.9	12.94	3.55	2.60	6.61
NB	Max - 1	NR Band n77 HPUE	Ant.E	EVS-NB 24.4 kbit/s	650000 3750 MHz	100 MHz	DFT-s-OFDM QPSK	1/1	26.9	15.69	2.09	1.34	8.95
WB	Max - 1	WiFi 2.4GHz 802.11b	Ant.D	EVS-WB 24.4 kbit/s	CH.6 2437 MHz	20 MHz	DSSS 1 Mbps	N/A	26.5	12.50	2.19	1.80	8.37
NB	Max - 1	WiFi 2.4GHz 802.11b	Ant.D	EVS-NB 24.4 kbit/s	CH.6 2437 MHz	20 MHz	DSSS 1 Mbps	N/A	26.5	15.80	2.01	1.06	8.39
WB	Max - 1	WiFi 5GHz 802.11a	Ant.D	EVS-WB 24.4 kbit/s	CH.40 5200 MHz	20 MHz	BPSK 6 Mbps	N/A	26.2	12.21	1.93	1.20	7.73
NB	Max - 1	WiFi 5GHz 802.11a	Ant.D	EVS-NB 24.4 kbit/s	CH.40 5200 MHz	20 MHz	BPSK 6 Mbps	N/A	26.5	15.90	2.17	1.33	8.86

8N Mounting Force

Codec (NB or WB)	Volume Control Level	Mode / Band	Antenna	Voice Codec / Codec bitrate (kbps)	Channel and Frequency	Bandwidth	Waveform / Modulation	RB (Allocation/ Offset)	Volume Control Results				
									8N				
									Noise (LAF_MAX) (dBA)	Conversational Gain (dB)	Frequency Response Margin (dB)		FN-SDNR margin (dB)
		FF	DF										
WB	Max - 1	LTE Band 66	Ant.A	EVS-WB 24.4 kbit/s	132322 1745 MHz	20 MHz	QPSK	1/0	26.1	16.78	3.36	3.10	8.20
NB	Max - 1	LTE Band 66	Ant.A	EVS-NB 24.4 kbit/s	132322 1745 MHz	20 MHz	QPSK	1/0	26.1	19.78	2.93	2.42	9.90
WB	Max - 1	LTE Band 41 PC2	Ant.A	EVS-WB 24.4 kbit/s	40620 2593 MHz	20 MHz	QPSK	1/0	26.4	16.69	3.39	3.10	5.20
NB	Max - 1	LTE Band 41 PC2	Ant.A	EVS-NB 24.4 kbit/s	40620 2593 MHz	20 MHz	QPSK	1/0	26.4	19.73	2.66	2.23	8.60
WB	Max - 1	NR Band n66	Ant.A	EVS-WB 24.4 kbit/s	349000 1745.00 MHz	40 MHz	DFT-s-OFDM QPSK	1/1	27.5	16.88	3.48	2.90	6.20
NB	Max - 1	NR Band n66	Ant.A	EVS-NB 24.4 kbit/s	349000 1745.00 MHz	40 MHz	DFT-s-OFDM QPSK	1/1	27.1	19.32	2.70	2.38	9.50
WB	Max - 1	NR Band n77 HPUE	Ant.E	EVS-WB 24.4 kbit/s	650000 3750 MHz	100 MHz	DFT-s-OFDM QPSK	1/1	26.5	16.85	3.47	3.10	8.10
NB	Max - 1	NR Band n77 HPUE	Ant.E	EVS-NB 24.4 kbit/s	650000 3750 MHz	100 MHz	DFT-s-OFDM QPSK	1/1	26.5	19.57	2.34	1.99	7.90
WB	Max - 1	WiFi 2.4GHz 802.11b	Ant.D	EVS-WB 24.4 kbit/s	CH.6 2437 MHz	20 MHz	DSSS 1 Mbps	N/A	26.5	16.70	2.95	2.40	8.00
NB	Max - 1	WiFi 2.4GHz 802.11b	Ant.D	EVS-NB 24.4 kbit/s	CH.6 2437 MHz	20 MHz	DSSS 1 Mbps	N/A	26.5	19.98	2.17	1.76	9.60
WB	Max - 1	WiFi 5GHz 802.11a	Ant.D	EVS-WB 24.4 kbit/s	CH.40 5200 MHz	20 MHz	BPSK 6 Mbps	N/A	26.2	16.83	3.26	2.60	4.70
NB	Max - 1	WiFi 5GHz 802.11a	Ant.D	EVS-NB 24.4 kbit/s	CH.40 5200 MHz	20 MHz	BPSK 6 Mbps	N/A	26.2	20.71	2.14	1.54	10.10

Note(s):

- For all technologies, it is observed that EVS-WB 24.4 kbps is the worst-case.

9.2. Antenna and Air Interface Investigation for VoLTE/VoNR/VoWiFi

Using the worst-case codec found in sec.9.1, a limited set of RBs/modulations/bandwidths/channels/bands/data rates were tested to confirm that there is no effect to compliance when changing the air interface.

2N Mounting Force – VoLTE FDD

Codec (NB or WB)	Volume Control Level	Mode / Band	Antenna	Voice Codec / Codec bitrate (kbps)	Channel and Frequency	Bandwidth	Waveform / Modulation	RB (Allocation/ Offset)	Volume Control Results				
									2N				FN-SDNR margin (dB)
									Noise (LAF_MAX) (dBA)	Conversational Gain (dB)	Frequency Response Margin (dB)		
FF	DF												
WB	Max - 1	LTE Band 66	Ant.A	EVS-WB 24.4 kbit/s	132322 1745 MHz	20 MHz	QPSK	1/0	26.1	12.46	3.25	2.30	5.98
WB	Max - 1		Ant.B	EVS-WB 24.4 kbit/s	132322 1745 MHz	20 MHz	QPSK	1/0	26.1	12.62	3.44	2.50	7.33
WB	Max - 1		Ant.A	EVS-WB 24.4 kbit/s	132322 1745 MHz	20 MHz	QPSK	1/49	26.7	12.64	2.93	1.80	8.04
WB	Max - 1		Ant.A	EVS-WB 24.4 kbit/s	132322 1745 MHz	20 MHz	QPSK	1/99	26.7	12.64	3.19	2.10	7.04
WB	Max - 1		Ant.A	EVS-WB 24.4 kbit/s	132322 1745 MHz	20 MHz	QPSK	50/0	26.7	12.63	2.89	1.90	7.64
WB	Max - 1		Ant.A	EVS-WB 24.4 kbit/s	132322 1745 MHz	20 MHz	QPSK	50/24	26.7	12.61	3.08	1.90	7.21
WB	Max - 1		Ant.A	EVS-WB 24.4 kbit/s	132322 1745 MHz	20 MHz	QPSK	50/50	26.7	12.58	2.90	2.20	6.77
WB	Max - 1		Ant.A	EVS-WB 24.4 kbit/s	132322 1745 MHz	20 MHz	QPSK	100/0	26.7	12.59	3.12	2.10	6.40
WB	Max - 1		Ant.A	EVS-WB 24.4 kbit/s	132322 1745 MHz	20 MHz	16QAM	1/0	26.7	12.56	3.12	2.00	6.08
WB	Max - 1		Ant.A	EVS-WB 24.4 kbit/s	132322 1745 MHz	20 MHz	64QAM	1/0	26.7	12.58	3.24	2.20	5.89
WB	Max - 1		Ant.A	EVS-WB 24.4 kbit/s	132322 1745 MHz	20 MHz	256QAM	1/0	26.7	12.54	3.02	2.00	5.70
WB	Max - 1		Ant.A	EVS-WB 24.4 kbit/s	132322 1745 MHz	15 MHz	QPSK	1/0	26.7	12.53	3.18	2.20	7.43
WB	Max - 1		Ant.A	EVS-WB 24.4 kbit/s	132322 1745 MHz	10 MHz	QPSK	1/0	26.7	12.56	3.02	1.90	5.50
WB	Max - 1		Ant.A	EVS-WB 24.4 kbit/s	132322 1745 MHz	5 MHz	QPSK	1/0	26.7	12.56	2.95	2.00	5.61
WB	Max - 1		Ant.A	EVS-WB 24.4 kbit/s	132322 1745 MHz	3 MHz	QPSK	1/0	26.7	12.54	3.14	2.20	5.56
WB	Max - 1		Ant.A	EVS-WB 24.4 kbit/s	132322 1745 MHz	1.4 MHz	QPSK	1/0	26.7	12.52	3.16	2.00	7.23
WB	Max - 1		Ant.A	EVS-WB 24.4 kbit/s	132072 1720 MHz	20 MHz	QPSK	1/0	26.7	12.56	3.24	2.10	7.76
WB	Max - 1		Ant.A	EVS-WB 24.4 kbit/s	132572 1770 MHz	20 MHz	QPSK	1/0	26.7	12.57	3.31	2.30	6.75
WB	Max - 1	LTE Band 2	Ant.A	EVS-WB 24.4 kbit/s	18900 1880 MHz	20 MHz	QPSK	1/0	26.7	12.52	3.23	2.40	5.86
NB	Max - 1		Ant.A	EVS-NB 24.4 kbit/s	18900 1880 MHz	20 MHz	QPSK	1/0	26.7	15.55	2.32	1.49	9.31
WB	Max - 1	LTE Band 4	Ant.A	EVS-WB 24.4 kbit/s	20175 1732.5 MHz	20 MHz	QPSK	1/0	26.7	12.53	3.34	2.20	7.87
NB	Max - 1		Ant.A	EVS-NB 24.4 kbit/s	20175 1732.5 MHz	20 MHz	QPSK	1/0	26.7	15.55	2.48	1.40	9.35
WB	Max - 1	LTE Band 5	Ant.A	EVS-WB 24.4 kbit/s	20525 836.5 MHz	10 MHz	QPSK	1/0	26.7	12.51	3.37	2.60	6.92
NB	Max - 1		Ant.A	EVS-NB 24.4 kbit/s	20525 836.5 MHz	10 MHz	QPSK	1/0	26.7	15.66	2.23	1.38	9.84
WB	Max - 1	LTE Band 7	Ant.A	EVS-WB 24.4 kbit/s	21100 2535 MHz	20 MHz	QPSK	1/0	26.7	12.57	3.21	2.20	5.97
NB	Max - 1		Ant.A	EVS-NB 24.4 kbit/s	21100 2535 MHz	20 MHz	QPSK	1/0	26.7	15.67	2.15	1.29	9.47
WB	Max - 1	LTE Band 12	Ant.A	EVS-WB 24.4 kbit/s	23095 707.5 MHz	10 MHz	QPSK	1/0	26.7	12.60	2.29	1.60	7.08
NB	Max - 1		Ant.A	EVS-NB 24.4 kbit/s	23095 707.5 MHz	10 MHz	QPSK	1/0	26.7	15.78	2.00	1.05	7.27
WB	Max - 1	LTE Band 13	Ant.A	EVS-WB 24.4 kbit/s	23230 782 MHz	10 MHz	QPSK	1/0	26.7	12.55	3.27	2.20	4.14
NB	Max - 1		Ant.A	EVS-NB 24.4 kbit/s	23230 782 MHz	10 MHz	QPSK	1/0	26.7	15.71	2.16	1.34	8.41
WB	Max - 1	LTE Band 14	Ant.A	EVS-WB 24.4 kbit/s	23330 793 MHz	10 MHz	QPSK	1/0	26.7	12.56	3.27	2.20	6.38
NB	Max - 1		Ant.A	EVS-NB 24.4 kbit/s	23330 793 MHz	10 MHz	QPSK	1/0	26.7	15.58	2.30	1.51	8.97
WB	Max - 1	LTE Band 25	Ant.A	EVS-WB 24.4 kbit/s	26365 1882.5 MHz	20 MHz	QPSK	1/0	26.7	12.55	3.32	2.20	5.86
NB	Max - 1		Ant.A	EVS-NB 24.4 kbit/s	26365 1882.5 MHz	20 MHz	QPSK	1/0	26.7	15.59	2.51	1.55	6.67
WB	Max - 1	LTE Band 26	Ant.A	EVS-WB 24.4 kbit/s	26865 831.5 MHz	15 MHz	QPSK	1/0	26.7	12.54	3.20	2.10	6.74
NB	Max - 1		Ant.A	EVS-NB 24.4 kbit/s	26865 831.5 MHz	15 MHz	QPSK	1/0	26.7	15.53	2.38	1.43	5.21
WB	Max - 1	LTE Band 30	Ant.A	EVS-WB 24.4 kbit/s	27710 2310 MHz	10 MHz	QPSK	1/0	26.7	12.49	3.26	2.30	6.39
NB	Max - 1		Ant.A	EVS-NB 24.4 kbit/s	27710 2310 MHz	10 MHz	QPSK	1/0	26.7	15.67	2.14	1.19	9.19
WB	Max - 1	LTE Band 71	Ant.A	EVS-WB 24.4 kbit/s	133297 680.5 MHz	20 MHz	QPSK	1/0	26.7	12.52	3.13	2.00	7.23
NB	Max - 1		Ant.A	EVS-NB 24.4 kbit/s	133297 680.5 MHz	20 MHz	QPSK	1/0	26.7	15.58	2.46	1.56	9.56

2N Mounting Force – VoLTE TDD

Codec (NB or WB)	Volume Control Level	Mode / Band	Antenna	Voice Codec / Codec bitrate (kbps)	Channel and Frequency	Bandwidth	Waveform / Modulation	RB (Allocation/ Offset)	Volume Control Results				
									2N				PN-SDNR margin (dB)
									Noise (LAF_MAX) (dBA)	Conversational Gain (dB)	Frequency Response Margin (dB)		
FF	DF												
WB	Max - 1	LTE Band 41 PC2	Ant.A	EVS-WB 24.4 kbit/s	40620 2593 MHz	20 MHz	QPSK	1/0	26.4	12.17	3.17	2.10	5.47
WB	Max - 1		Ant.A	EVS-WB 24.4 kbit/s	40620 2593 MHz	20 MHz	QPSK	1/49	26.7	12.30	3.29	2.30	7.10
WB	Max - 1		Ant.A	EVS-WB 24.4 kbit/s	40620 2593 MHz	20 MHz	QPSK	1/99	26.7	12.32	3.22	2.10	5.24
WB	Max - 1		Ant.A	EVS-WB 24.4 kbit/s	40620 2593 MHz	20 MHz	QPSK	50/0	26.7	12.30	3.31	2.30	5.82
WB	Max - 1		Ant.A	EVS-WB 24.4 kbit/s	40620 2593 MHz	20 MHz	QPSK	50/24	26.7	12.35	3.21	2.10	6.02
WB	Max - 1		Ant.A	EVS-WB 24.4 kbit/s	40620 2593 MHz	20 MHz	QPSK	50/50	26.7	12.34	3.00	2.00	6.65
WB	Max - 1		Ant.A	EVS-WB 24.4 kbit/s	40620 2593 MHz	20 MHz	QPSK	100/0	26.7	12.32	3.17	2.20	5.77
WB	Max - 1		Ant.A	EVS-WB 24.4 kbit/s	40620 2593 MHz	20 MHz	16QAM	1/0	26.7	12.32	3.08	2.00	5.88
WB	Max - 1		Ant.A	EVS-WB 24.4 kbit/s	40620 2593 MHz	20 MHz	64QAM	1/0	26.7	12.32	3.21	2.20	5.94
WB	Max - 1		Ant.A	EVS-WB 24.4 kbit/s	40620 2593 MHz	20 MHz	256QAM	1/0	26.7	12.34	2.99	1.90	7.30
WB	Max - 1		Ant.A	EVS-WB 24.4 kbit/s	40620 2593 MHz	15 MHz	QPSK	1/0	26.7	12.36	2.65	2.00	5.64
WB	Max - 1		Ant.A	EVS-WB 24.4 kbit/s	40620 2593 MHz	10 MHz	QPSK	1/0	26.7	12.36	2.95	1.80	5.31
WB	Max - 1		Ant.A	EVS-WB 24.4 kbit/s	40620 2593 MHz	5 MHz	QPSK	1/0	26.7	12.35	2.71	2.00	4.64
WB	Max - 1		Ant.A	EVS-WB 24.4 kbit/s	39750 2506 MHz	20 MHz	QPSK	1/0	26.7	12.34	3.18	2.00	5.44
WB	Max - 1		Ant.A	EVS-WB 24.4 kbit/s	40185 2549.5 MHz	20 MHz	QPSK	1/0	26.7	12.35	3.05	1.90	5.63
WB	Max - 1		Ant.A	EVS-WB 24.4 kbit/s	41055 2636.5 MHz	20 MHz	QPSK	1/0	26.7	12.31	3.15	2.10	7.92
WB	Max - 1		Ant.A	EVS-WB 24.4 kbit/s	41490 2680 MHz	20 MHz	QPSK	1/0	26.7	12.33	3.13	2.00	6.84
WB	Max - 1		LTE Band 38	Ant.A	EVS-WB 24.4 kbit/s	40620 2593 MHz	20 MHz	QPSK	1/0	26.4	12.55	3.24	2.20
NB	Max - 1	Ant.A		EVS-NB 24.4 kbit/s	40620 2593 MHz	20 MHz	QPSK	1/0	26.4	15.65	2.17	1.34	4.46
WB	Max - 1	LTE Band 41 PC3	Ant.A	EVS-WB 24.4 kbit/s	38000 2595 MHz	20 MHz	QPSK	1/0	26.7	12.30	3.29	2.20	5.28
NB	Max - 1		Ant.A	EVS-NB 24.4 kbit/s	38000 2595 MHz	20 MHz	QPSK	1/0	26.7	15.41	2.32	1.33	9.13
WB	Max - 1	LTE Band 48	Ant.E	EVS-WB 24.4 kbit/s	55773 3603.3 MHz	20 MHz	QPSK	1/0	26.4	12.54	3.16	2.10	5.69
NB	Max - 1		Ant.E	EVS-NB 24.4 kbit/s	55773 3603.3 MHz	20 MHz	QPSK	1/0	26.4	15.67	1.95	1.12	5.60

2N Mounting Force – VoNR FDD

Codec (NB or WB)	Volume Control Level	Mode / Band	Antenna	Voice Codec / Codec bitrate (kbps)	Channel and Frequency	Bandwidth	Waveform/ Modulation	RB (Allocation/ Offset)	Volume Control Results				
									2N				
									Noise (LAF_MAX) (dBA)	Conversational Gain (dB)	Frequency Response Margin (dB)		FN-SDNR margin (dB)
FF	DF												
WB	Max - 1	NR Band n66	AntA	EVS-WB 24.4 kbit/s	349000 1745.00 MHz	40 MHz	DFT-s-OFDM QPSK	1/1	27.1	12.64	3.42	3.10	8.31
WB	Max - 1		AntB	EVS-WB 24.4 kbit/s	349000 1745.00 MHz	40 MHz	DFT-s-OFDM QPSK	1/1	27.1	12.70	3.51	3.10	7.71
WB	Max - 1		AntA	EVS-WB 24.4 kbit/s	349000 1745.00 MHz	40 MHz	DFT-s-OFDM QPSK	1/107	27.1	12.75	3.51	3.10	7.75
WB	Max - 1		AntA	EVS-WB 24.4 kbit/s	349000 1745.00 MHz	40 MHz	DFT-s-OFDM QPSK	1/214	27.1	12.70	3.55	3.20	7.36
WB	Max - 1		AntA	EVS-WB 24.4 kbit/s	349000 1745.00 MHz	40 MHz	DFT-s-OFDM QPSK	108/0	27.1	12.72	3.50	3.20	7.05
WB	Max - 1		AntA	EVS-WB 24.4 kbit/s	349000 1745.00 MHz	40 MHz	DFT-s-OFDM QPSK	108/54	27.1	12.70	3.53	3.30	7.92
WB	Max - 1		AntA	EVS-WB 24.4 kbit/s	349000 1745.00 MHz	40 MHz	DFT-s-OFDM QPSK	108/108	27.1	12.74	3.58	3.00	6.22
WB	Max - 1		AntA	EVS-WB 24.4 kbit/s	349000 1745.00 MHz	40 MHz	DFT-s-OFDM QPSK	216/0	27.1	12.72	3.59	3.20	7.71
WB	Max - 1		AntA	EVS-WB 24.4 kbit/s	349000 1745.00 MHz	40 MHz	DFT-s-OFDM pi/2 BPSK	1/1	27.1	12.72	3.55	3.30	7.86
WB	Max - 1		AntA	EVS-WB 24.4 kbit/s	349000 1745.00 MHz	40 MHz	DFT-s-OFDM 16QAM	1/1	27.1	12.72	3.60	3.30	7.82
WB	Max - 1		AntA	EVS-WB 24.4 kbit/s	349000 1745.00 MHz	40 MHz	DFT-s-OFDM 64QAM	1/1	27.1	12.71	3.47	3.10	7.02
WB	Max - 1		AntA	EVS-WB 24.4 kbit/s	349000 1745.00 MHz	40 MHz	DFT-s-OFDM 256QAM	1/1	27.1	12.76	3.49	3.00	7.99
WB	Max - 1		AntA	EVS-WB 24.4 kbit/s	349000 1745.00 MHz	40 MHz	CP-OFDM QPSK	1/1	27.1	12.69	3.48	3.10	8.05
WB	Max - 1		AntA	EVS-WB 24.4 kbit/s	349000 1745.00 MHz	40 MHz	CP-OFDM QPSK	1/107	27.1	12.74	3.52	3.00	7.08
WB	Max - 1		AntA	EVS-WB 24.4 kbit/s	349000 1745.00 MHz	40 MHz	CP-OFDM QPSK	1/214	27.1	12.80	3.53	3.10	7.18
WB	Max - 1		AntA	EVS-WB 24.4 kbit/s	349000 1745.00 MHz	40 MHz	CP-OFDM QPSK	108/0	27.1	12.76	3.52	3.10	7.52
WB	Max - 1		AntA	EVS-WB 24.4 kbit/s	349000 1745.00 MHz	40 MHz	CP-OFDM QPSK	108/54	27.1	12.77	3.50	3.20	7.70
WB	Max - 1		AntA	EVS-WB 24.4 kbit/s	349000 1745.00 MHz	40 MHz	CP-OFDM QPSK	108/108	27.1	12.76	3.50	3.10	5.49
WB	Max - 1		AntA	EVS-WB 24.4 kbit/s	349000 1745.00 MHz	40 MHz	CP-OFDM QPSK	216/0	27.1	12.77	3.49	2.90	7.93
WB	Max - 1		AntA	EVS-WB 24.4 kbit/s	349000 1745.00 MHz	40 MHz	CP-OFDM 16QAM	1/1	27.1	12.79	3.57	3.00	7.13
WB	Max - 1		AntA	EVS-WB 24.4 kbit/s	349000 1745.00 MHz	40 MHz	CP-OFDM 64QAM	1/1	27.1	12.76	3.50	3.10	7.87
WB	Max - 1		AntA	EVS-WB 24.4 kbit/s	349000 1745.00 MHz	40 MHz	CP-OFDM 256QAM	1/1	27.1	12.78	3.59	3.20	7.28
WB	Max - 1		AntA	EVS-WB 24.4 kbit/s	349000 1745.00 MHz	30 MHz	DFT-s-OFDM QPSK	1/1	27.1	12.75	3.59	3.10	7.62
WB	Max - 1		AntA	EVS-WB 24.4 kbit/s	349000 1745.00 MHz	25 MHz	DFT-s-OFDM QPSK	1/1	27.1	12.75	3.60	3.20	7.58
WB	Max - 1		AntA	EVS-WB 24.4 kbit/s	349000 1745.00 MHz	20 MHz	DFT-s-OFDM QPSK	1/1	27.1	12.74	3.57	3.20	7.02
WB	Max - 1		AntA	EVS-WB 24.4 kbit/s	349000 1745.00 MHz	15 MHz	DFT-s-OFDM QPSK	1/1	27.1	12.68	3.56	3.20	7.45
WB	Max - 1		AntA	EVS-WB 24.4 kbit/s	349000 1745.00 MHz	10 MHz	DFT-s-OFDM QPSK	1/1	27.1	12.73	3.48	3.00	7.94
WB	Max - 1		AntA	EVS-WB 24.4 kbit/s	349000 1745.00 MHz	5 MHz	DFT-s-OFDM QPSK	1/1	27.1	12.73	3.53	3.10	6.47
WB	Max - 1		AntA	EVS-WB 24.4 kbit/s	346000 1730.00 MHz	40 MHz	DFT-s-OFDM QPSK	1/1	27.1	12.72	3.40	3.00	7.68
WB	Max - 1		AntA	EVS-WB 24.4 kbit/s	352000 1760.00 MHz	40 MHz	DFT-s-OFDM QPSK	1/1	27.1	12.69	3.54	3.30	7.70
WB	Max - 1	NR Band n2	AntA	EVS-WB 24.4 kbit/s	376000 1880.00 MHz	40 MHz	DFT-s-OFDM QPSK	1/1	27.1	12.74	3.61	3.00	7.34
NB	Max - 1		AntA	EVS-NB 24.4 kbit/s	376000 1880.00 MHz	40 MHz	DFT-s-OFDM QPSK	1/1	27.1	15.11	2.78	1.76	5.63
WB	Max - 1	NR Band n5	AntA	EVS-WB 24.4 kbit/s	167300 836.50 MHz	20 MHz	DFT-s-OFDM QPSK	1/1	27.1	12.77	3.50	2.80	7.67
NB	Max - 1		AntA	EVS-NB 24.4 kbit/s	167300 836.50 MHz	20 MHz	DFT-s-OFDM QPSK	1/1	27.1	15.24	2.42	1.39	10.32
WB	Max - 1	NR Band n25	AntA	EVS-WB 24.4 kbit/s	376500 1882.5 MHz	40 MHz	DFT-s-OFDM QPSK	1/1	27.1	12.71	3.59	3.20	7.97
NB	Max - 1		AntA	EVS-NB 24.4 kbit/s	376500 1882.5 MHz	40 MHz	DFT-s-OFDM QPSK	1/1	27.1	15.09	2.75	1.80	8.68
WB	Max - 1	NR Band n30	AntA	EVS-WB 24.4 kbit/s	462000 2310 MHz	10 MHz	DFT-s-OFDM QPSK	1/1	27.1	12.77	3.48	3.00	7.99
NB	Max - 1		AntA	EVS-NB 24.4 kbit/s	462000 2310 MHz	10 MHz	DFT-s-OFDM QPSK	1/1	27.1	15.19	2.72	1.88	8.99
WB	Max - 1	NR Band n70	AntA	EVS-WB 24.4 kbit/s	340500 1702.5 MHz	15 MHz	DFT-s-OFDM QPSK	1/1	27.1	12.74	3.48	3.10	6.62
NB	Max - 1		AntA	EVS-NB 24.4 kbit/s	340500 1702.5 MHz	15 MHz	DFT-s-OFDM QPSK	1/1	27.1	15.29	2.31	1.46	8.52
WB	Max - 1	NR Band n71	AntA	EVS-WB 24.4 kbit/s	136100 680.5 MHz	20 MHz	DFT-s-OFDM QPSK	1/1	27.1	12.73	3.62	2.90	6.83
NB	Max - 1		AntA	EVS-NB 24.4 kbit/s	136100 680.5 MHz	20 MHz	DFT-s-OFDM QPSK	1/1	27.1	15.23	2.51	1.72	8.22

2N Mounting Force – VoNR TDD

Codec (NB or WB)	Volume Control Level	Mode / Band	Antenna	Voice Codec / Codec bitrate (kbps)	Channel and Frequency	Bandwidth	Waveform/ Modulation	RB (Allocation/ Offset)	Volume Control Results				
									2N				
									Noise (LAF_MAX) (dBA)	Conversational Gain (dB)	Frequency Response Margin (dB)		FN-SDNR margin (dB)
FF	DF												
WB	Max - 1	NR Band n77 HPUE	Ant.E	EVS-WB 24.4 kbit/s	650000 3750 MHz	100 MHz	DFT-s-OFDM QPSK	1/1	26.9	12.94	3.55	2.60	6.61
WB	Max - 1		Ant.E	EVS-WB 24.4 kbit/s	650000 3750 MHz	100 MHz	DFT-s-OFDM QPSK	1/136	26.9	12.95	3.34	2.30	7.49
WB	Max - 1		Ant.E	EVS-WB 24.4 kbit/s	650000 3750 MHz	100 MHz	DFT-s-OFDM QPSK	1/271	26.9	13.04	3.46	2.50	7.93
WB	Max - 1		Ant.E	EVS-WB 24.4 kbit/s	650000 3750 MHz	100 MHz	DFT-s-OFDM QPSK	135/0	26.9	13.08	3.49	2.40	6.88
WB	Max - 1		Ant.E	EVS-WB 24.4 kbit/s	650000 3750 MHz	100 MHz	DFT-s-OFDM QPSK	135/69	26.9	13.04	3.47	2.70	7.72
WB	Max - 1		Ant.E	EVS-WB 24.4 kbit/s	650000 3750 MHz	100 MHz	DFT-s-OFDM QPSK	135/138	26.9	13.02	3.45	2.80	7.58
WB	Max - 1		Ant.E	EVS-WB 24.4 kbit/s	650000 3750 MHz	100 MHz	DFT-s-OFDM QPSK	270/0	26.9	13.04	3.42	2.60	6.37
WB	Max - 1		Ant.E	EVS-WB 24.4 kbit/s	650000 3750 MHz	100 MHz	DFT-s-OFDM pi/2 BPSK	1/1	26.9	13.05	3.54	2.80	7.80
WB	Max - 1		Ant.E	EVS-WB 24.4 kbit/s	650000 3750 MHz	100 MHz	DFT-s-OFDM 16QAM	1/1	26.9	13.03	3.49	2.40	7.89
WB	Max - 1		Ant.E	EVS-WB 24.4 kbit/s	650000 3750 MHz	100 MHz	DFT-s-OFDM 64QAM	1/1	26.9	13.01	3.43	2.60	7.48
WB	Max - 1		Ant.E	EVS-WB 24.4 kbit/s	650000 3750 MHz	100 MHz	DFT-s-OFDM 256QAM	1/1	26.9	13.03	3.40	2.40	7.89
WB	Max - 1		Ant.E	EVS-WB 24.4 kbit/s	650000 3750 MHz	100 MHz	CP-OFDM QPSK	1/1	26.9	12.97	3.39	2.40	8.22
WB	Max - 1		Ant.E	EVS-WB 24.4 kbit/s	650000 3750 MHz	100 MHz	CP-OFDM QPSK	1/136	26.9	13.03	3.40	2.30	4.34
WB	Max - 1		Ant.E	EVS-WB 24.4 kbit/s	650000 3750 MHz	100 MHz	CP-OFDM QPSK	1/271	26.9	13.00	3.47	2.60	6.95
WB	Max - 1		Ant.E	EVS-WB 24.4 kbit/s	650000 3750 MHz	100 MHz	CP-OFDM QPSK	135/0	26.9	13.04	3.41	2.40	7.70
WB	Max - 1		Ant.E	EVS-WB 24.4 kbit/s	650000 3750 MHz	100 MHz	CP-OFDM QPSK	135/69	26.9	13.00	3.47	2.80	6.93
WB	Max - 1		Ant.E	EVS-WB 24.4 kbit/s	650000 3750 MHz	100 MHz	CP-OFDM QPSK	135/138	26.9	13.01	3.51	2.50	7.72
WB	Max - 1		Ant.E	EVS-WB 24.4 kbit/s	650000 3750 MHz	100 MHz	CP-OFDM QPSK	270/0	26.9	13.04	3.47	2.40	7.72
WB	Max - 1		Ant.E	EVS-WB 24.4 kbit/s	650000 3750 MHz	100 MHz	CP-OFDM 16QAM	1/1	26.9	13.01	3.50	2.70	8.13
WB	Max - 1		Ant.E	EVS-WB 24.4 kbit/s	650000 3750 MHz	100 MHz	CP-OFDM 64QAM	1/1	26.9	13.01	3.48	2.30	7.60
WB	Max - 1		Ant.E	EVS-WB 24.4 kbit/s	650000 3750 MHz	100 MHz	CP-OFDM 256QAM	1/1	26.9	13.05	3.48	2.40	7.84
WB	Max - 1		Ant.E	EVS-WB 24.4 kbit/s	650000 3750 MHz	90 MHz	DFT-s-OFDM QPSK	1/1	26.9	13.02	3.48	2.50	8.29
WB	Max - 1		Ant.E	EVS-WB 24.4 kbit/s	650000 3750 MHz	80 MHz	DFT-s-OFDM QPSK	1/1	26.9	13.00	3.52	2.60	7.01
WB	Max - 1		Ant.E	EVS-WB 24.4 kbit/s	650000 3750 MHz	70 MHz	DFT-s-OFDM QPSK	1/1	26.9	13.00	3.49	2.60	7.74
WB	Max - 1		Ant.E	EVS-WB 24.4 kbit/s	650000 3750 MHz	60 MHz	DFT-s-OFDM QPSK	1/1	26.9	12.99	3.55	2.60	7.94
WB	Max - 1		Ant.E	EVS-WB 24.4 kbit/s	650000 3750 MHz	50 MHz	DFT-s-OFDM QPSK	1/1	26.9	13.00	3.52	2.50	8.36
WB	Max - 1		Ant.E	EVS-WB 24.4 kbit/s	650000 3750 MHz	40 MHz	DFT-s-OFDM QPSK	1/1	26.9	13.01	3.46	2.60	8.14
WB	Max - 1		Ant.E	EVS-WB 24.4 kbit/s	650000 3750 MHz	30 MHz	DFT-s-OFDM QPSK	1/1	26.9	13.03	3.48	2.50	8.04
WB	Max - 1		Ant.E	EVS-WB 24.4 kbit/s	650000 3750 MHz	25 MHz	DFT-s-OFDM QPSK	1/1	26.9	13.00	3.53	2.60	8.09
WB	Max - 1		Ant.E	EVS-WB 24.4 kbit/s	650000 3750 MHz	20 MHz	DFT-s-OFDM QPSK	1/1	26.9	13.00	3.48	2.60	7.60
WB	Max - 1		Ant.E	EVS-WB 24.4 kbit/s	650000 3750 MHz	15 MHz	DFT-s-OFDM QPSK	1/1	26.9	13.01	3.52	2.40	7.90
WB	Max - 1		Ant.E	EVS-WB 24.4 kbit/s	650000 3750 MHz	10 MHz	DFT-s-OFDM QPSK	1/1	26.9	13.00	3.47	2.60	6.37
WB	Max - 1	Ant.E	EVS-WB 24.4 kbit/s	633334 3500.01 MHz	100 MHz	DFT-s-OFDM QPSK	1/1	26.9	13.00	3.49	2.60	8.24	
WB	Max - 1	Ant.E	EVS-WB 24.4 kbit/s	662000 3930 MHz	100 MHz	DFT-s-OFDM QPSK	1/1	26.9	13.04	3.49	2.70	7.73	
WB	Max - 1	NR Band n41 HPUE	Ant.A	EVS-WB 24.4 kbit/s	518598 2592.99 MHz	100 MHz	DFT-s-OFDM QPSK	1/1	26.9	13.02	3.49	2.50	7.15
NB	Max - 1		Ant.A	EVS-NB 24.4 kbit/s	518598 2592.99 MHz	100 MHz	DFT-s-OFDM QPSK	1/1	26.9	15.68	2.15	1.22	8.86
WB	Max - 1	NR Band n48	Ant.E	EVS-WB 24.4 kbit/s	641666 3624.99 MHz	40 MHz	DFT-s-OFDM QPSK	1/1	26.9	13.03	3.47	2.40	5.55
NB	Max - 1		Ant.E	EVS-NB 24.4 kbit/s	641666 3624.99 MHz	40 MHz	DFT-s-OFDM QPSK	1/1	26.9	15.67	1.95	1.09	4.28
WB	Max - 1	NR Band n78 HPUE	Ant.E	EVS-WB 24.4 kbit/s	650000 3750 MHz	100 MHz	DFT-s-OFDM QPSK	1/1	26.9	13.02	3.48	2.60	7.65
NB	Max - 1		Ant.E	EVS-NB 24.4 kbit/s	650000 3750 MHz	100 MHz	DFT-s-OFDM QPSK	1/1	26.9	15.66	2.06	1.25	10.72

2N Mounting Force – VoWiFi 2.4GHz

Codec (NB or WB)	Volume Control Level	Mode / Band	Antenna	Voice Codec / Codec bitrate (kbps)	Channel and Frequency	Bandwidth	Waveform / Modulation	RB (Allocation/ Offset)	Volume Control Results				
									2N				PN-SDNR margin (dB)
									Noise (LAF_MAX) (dBA)	Conversational Gain (dB)	Frequency Response Margin (dB)		
FF	DF												
WB	Max - 1	WiFi 2.4GHz 802.11b	Ant.D	EVS-WB 24.4 kbit/s	CH6 2437 MHz	20 MHz	DSSS 1 Mbps	N/A	26.5	12.50	2.19	1.80	8.37
WB	Max - 1		Ant.D	EVS-WB 24.4 kbit/s	CH6 2437 MHz	20 MHz	CCK 5.5 Mbps	N/A	26.5	12.70	2.49	2.20	7.99
WB	Max - 1		Ant.D	EVS-WB 24.4 kbit/s	CH6 2437 MHz	20 MHz	CCK 11 Mbps	N/A	26.5	12.73	2.51	1.90	6.10
WB	Max - 1		Ant.D	EVS-WB 24.4 kbit/s	CH1 2412 MHz	20 MHz	DSSS 1 Mbps	N/A	26.5	12.52	2.46	1.90	6.31
WB	Max - 1		Ant.D	EVS-WB 24.4 kbit/s	CH11 2462 MHz	20 MHz	DSSS 1 Mbps	N/A	26.5	12.52	2.14	1.70	6.97
WB	Max - 1	WiFi 2.4GHz 802.11g	Ant.D	EVS-WB 24.4 kbit/s	CH6 2437 MHz	20 MHz	BPSK 6 Mbps	N/A	26.5	12.75	2.67	2.20	7.84
NB	Max - 1		Ant.D	EVS-NB 24.4 kbit/s	CH6 2437 MHz	20 MHz	BPSK 6 Mbps	N/A	26.5	15.81	1.99	1.04	9.74
WB	Max - 1	WiFi 2.4GHz 802.11n HT20	Ant.D	EVS-WB 24.4 kbit/s	CH6 2437 MHz	20 MHz	MCS 0 6.5 Mbps	N/A	26.5	12.74	2.89	2.00	7.82
NB	Max - 1		Ant.D	EVS-NB 24.4 kbit/s	CH6 2437 MHz	20 MHz	MCS 0 6.5 Mbps	N/A	26.5	15.84	1.96	1.01	10.60

2N Mounting Force – VoWiFi U-NII

Codec (NB or WB)	Volume Control Level	Mode / Band	Antenna	Voice Codec / Codec bitrate (kbps)	Channel and Frequency	Bandwidth	Waveform / Modulation	RB (Allocation/ Offset)	Volume Control Results				
									2N				PN-SDNR margin (dB)
									Noise (LAF_MAX) (dBA)	Conversational Gain (dB)	Frequency Response Margin (dB)		
FF	DF												
WB	Max - 1	WiFi 5GHz 802.11a U-NII-1	Ant.D	EVS-WB 24.4 kbit/s	CH40 5200 MHz	20 MHz	BPSK 6 Mbps	N/A	26.2	12.21	1.93	1.20	7.73
WB	Max - 1		Ant.D	EVS-WB 24.4 kbit/s	CH40 5200 MHz	20 MHz	QPSK 18 Mbps	N/A	26.2	12.25	2.47	2.20	7.21
WB	Max - 1		Ant.D	EVS-WB 24.4 kbit/s	CH40 5200 MHz	20 MHz	64QAM 54 Mbps	N/A	26.2	12.81	2.49	1.70	7.26
WB	Max - 1		Ant.D	EVS-WB 24.4 kbit/s	CH36 5180 MHz	20 MHz	BPSK 6 Mbps	N/A	26.2	12.22	2.27	1.60	6.44
WB	Max - 1		Ant.D	EVS-WB 24.4 kbit/s	CH48 5240 MHz	20 MHz	BPSK 6 Mbps	N/A	26.2	12.25	2.35	1.60	7.25
WB	Max - 1	WiFi 5GHz 802.11n HT20 U-NII-1	Ant.D	EVS-WB 24.4 kbit/s	CH40 5200 MHz	20 MHz	MCS 0 6.5 Mbps	N/A	26.2	12.18	2.32	1.70	7.52
WB	Max - 1		Ant.D	EVS-WB 24.4 kbit/s	CH40 5200 MHz	20 MHz	MCS 3 26 Mbps	N/A	26.2	12.82	2.20	1.50	6.42
WB	Max - 1		Ant.D	EVS-WB 24.4 kbit/s	CH40 5200 MHz	20 MHz	MCS 7 65 Mbps	N/A	26.2	12.80	2.46	1.60	6.60
NB	Max - 1		Ant.D	EVS-NB 24.4 kbit/s	CH40 5200 MHz	20 MHz	MCS 0 6.5 Mbps	N/A	26.2	15.71	1.94	1.00	8.89
WB	Max - 1	WiFi 5GHz 802.11n HT40 U-NII-1	Ant.D	EVS-WB 24.4 kbit/s	CH38 5190 MHz	40 MHz	MCS 0 6.5 Mbps	N/A	26.2	12.26	2.37	1.80	8.12
WB	Max - 1		Ant.D	EVS-WB 24.4 kbit/s	CH38 5190 MHz	40 MHz	MCS 3 54 Mbps	N/A	26.2	12.82	2.18	1.70	7.83
WB	Max - 1		Ant.D	EVS-WB 24.4 kbit/s	CH38 5190 MHz	40 MHz	MCS 7 135 Mbps	N/A	26.2	12.83	2.11	1.70	7.00
NB	Max - 1		Ant.D	EVS-NB 24.4 kbit/s	CH38 5190 MHz	40 MHz	MCS 0 13.5 Mbps	N/A	26.2	15.70	2.00	1.05	9.37
WB	Max - 1	WiFi 5GHz 802.11ac VHT20 U-NII-1	Ant.D	EVS-WB 24.4 kbit/s	CH40 5200 MHz	20 MHz	MCS 0 6.5 Mbps	N/A	26.2	12.51	2.30	1.80	8.03
WB	Max - 1		Ant.D	EVS-WB 24.4 kbit/s	CH40 5200 MHz	20 MHz	MCS 4 39 Mbps	N/A	26.2	12.75	2.62	2.10	8.05
WB	Max - 1		Ant.D	EVS-WB 24.4 kbit/s	CH40 5200 MHz	20 MHz	MCS 8 78 Mbps	N/A	26.2	12.72	2.60	1.80	7.46
NB	Max - 1		Ant.D	EVS-NB 24.4 kbit/s	CH40 5200 MHz	20 MHz	MCS 0 6.5 Mbps	N/A	26.5	16.08	1.83	1.00	8.98
WB	Max - 1	WiFi 5GHz 802.11ac VHT40 U-NII-1	Ant.D	EVS-WB 24.4 kbit/s	CH38 5190 MHz	40 MHz	MCS 0 13.5 Mbps	N/A	26.2	12.58	2.26	1.60	8.45
WB	Max - 1		Ant.D	EVS-WB 24.4 kbit/s	CH38 5190 MHz	40 MHz	MCS 4 108 Mbps	N/A	26.2	12.71	2.66	1.90	7.58
WB	Max - 1		Ant.D	EVS-WB 24.4 kbit/s	CH38 5190 MHz	40 MHz	MCS 9 180 Mbps	N/A	26.2	12.70	2.45	1.80	8.36
NB	Max - 1		Ant.D	EVS-NB 24.4 kbit/s	CH38 5190 MHz	40 MHz	MCS 0 13.5 Mbps	N/A	26.5	15.92	2.20	1.17	9.68
WB	Max - 1	WiFi 5GHz 802.11ac VHT80 U-NII-1	Ant.D	EVS-WB 24.4 kbit/s	CH42 5210 MHz	80 MHz	MCS 0 29.3 Mbps	N/A	26.2	12.55	2.45	1.70	6.30
WB	Max - 1		Ant.D	EVS-WB 24.4 kbit/s	CH42 5210 MHz	80 MHz	MCS 4 175.5 Mbps	N/A	26.2	12.69	2.62	1.80	6.81
WB	Max - 1		Ant.D	EVS-WB 24.4 kbit/s	CH42 5210 MHz	80 MHz	MCS 9 390 Mbps	N/A	26.2	12.76	2.40	1.70	8.32
NB	Max - 1		Ant.D	EVS-NB 24.4 kbit/s	CH42 5210 MHz	80 MHz	MCS 0 29.3 Mbps	N/A	26.5	15.91	2.03	1.09	8.99
WB	Max - 1	WiFi 5GHz 802.11n HT20 U-NII-2C	Ant.D	EVS-WB 24.4 kbit/s	CH56 5280 MHz	20 MHz	MCS 0 6.5 Mbps	N/A	26.2	12.20	1.93	1.70	5.73
NB	Max - 1		Ant.D	EVS-NB 24.4 kbit/s	CH56 5280 MHz	20 MHz	MCS 0 6.5 Mbps	N/A	26.5	15.95	2.12	1.17	8.03
WB	Max - 1	WiFi 5GHz 802.11n HT20 U-NII-2C	Ant.D	EVS-WB 24.4 kbit/s	CH120 5600 MHz	20 MHz	MCS 0 6.5 Mbps	N/A	26.2	12.76	2.12	1.60	8.33
NB	Max - 1		Ant.D	EVS-NB 24.4 kbit/s	CH120 5600 MHz	20 MHz	MCS 0 6.5 Mbps	N/A	26.5	15.88	2.12	1.14	9.08
WB	Max - 1	WiFi 5GHz 802.11n HT20 U-NII-3	Ant.D	EVS-WB 24.4 kbit/s	CH157 5785 MHz	20 MHz	MCS 0 6.5 Mbps	N/A	26.2	12.67	2.84	1.80	6.65
NB	Max - 1		Ant.D	EVS-NB 24.4 kbit/s	CH157 5785 MHz	20 MHz	MCS 0 6.5 Mbps	N/A	26.5	15.91	2.15	1.26	8.88

8N Mounting Force – VoLTE FDD

Codec (NB or WB)	Volume Control Level	Mode / Band	Antenna	Voice Codec / Codec bitrate (kbps)	Channel and Frequency	Bandwidth	Waveform/ Modulation	RB (Allocation/ Offset)	Volume Control Results					
									8N					
									Noise (LAF_MAX) (dBA)	Conversational Gain (dB)	Frequency Response Margin (dB)		FN-SDNR margin (dB)	
FF	DF													
WB	Max - 1	LTE Band 66	Ant.A	EVS-WB 24.4 kbit/s	132322 1745 MHz	20 MHz	QPSK	1/0	26.1	16.78	3.36	3.10	8.20	
WB	Max - 1		Ant.B	EVS-WB 24.4 kbit/s	132322 1745 MHz	20 MHz	QPSK	1/0	26.1	16.93	3.39	2.90	6.50	
WB	Max - 1		Ant.A	EVS-WB 24.4 kbit/s	132322 1745 MHz	20 MHz	QPSK	1/49	26.3	16.90	3.38	3.00	6.90	
WB	Max - 1		Ant.A	EVS-WB 24.4 kbit/s	132322 1745 MHz	20 MHz	QPSK	1/99	26.3	16.91	3.43	3.10	6.60	
WB	Max - 1		Ant.A	EVS-WB 24.4 kbit/s	132322 1745 MHz	20 MHz	QPSK	50/0	26.3	16.88	3.44	3.00	7.80	
WB	Max - 1		Ant.A	EVS-WB 24.4 kbit/s	132322 1745 MHz	20 MHz	QPSK	50/24	26.3	16.93	3.36	3.10	6.10	
WB	Max - 1		Ant.A	EVS-WB 24.4 kbit/s	132322 1745 MHz	20 MHz	QPSK	50/50	26.3	16.87	3.41	3.00	7.10	
WB	Max - 1		Ant.A	EVS-WB 24.4 kbit/s	132322 1745 MHz	20 MHz	QPSK	100/0	26.3	16.89	3.36	3.10	6.70	
WB	Max - 1		Ant.A	EVS-WB 24.4 kbit/s	132322 1745 MHz	20 MHz	16QAM	1/0	26.3	16.86	3.36	3.00	6.90	
WB	Max - 1		Ant.A	EVS-WB 24.4 kbit/s	132322 1745 MHz	20 MHz	64QAM	1/0	26.3	16.88	3.32	2.90	6.00	
WB	Max - 1		Ant.A	EVS-WB 24.4 kbit/s	132322 1745 MHz	20 MHz	256QAM	1/0	26.3	16.84	3.43	3.10	8.00	
WB	Max - 1		Ant.A	EVS-WB 24.4 kbit/s	132322 1745 MHz	15 MHz	QPSK	1/0	26.3	16.89	3.36	2.90	6.30	
WB	Max - 1		Ant.A	EVS-WB 24.4 kbit/s	132322 1745 MHz	10 MHz	QPSK	1/0	26.3	16.87	3.43	3.00	6.70	
WB	Max - 1		Ant.A	EVS-WB 24.4 kbit/s	132322 1745 MHz	5 MHz	QPSK	1/0	26.3	16.87	3.37	3.10	7.80	
WB	Max - 1		Ant.A	EVS-WB 24.4 kbit/s	132322 1745 MHz	3 MHz	QPSK	1/0	26.3	16.82	3.39	2.80	6.20	
WB	Max - 1		Ant.A	EVS-WB 24.4 kbit/s	132322 1745 MHz	1.4 MHz	QPSK	1/0	26.3	16.98	3.29	2.80	6.40	
WB	Max - 1		Ant.A	EVS-WB 24.4 kbit/s	132072 1720 MHz	20 MHz	QPSK	1/0	26.3	17.00	3.29	2.80	6.50	
WB	Max - 1		Ant.A	EVS-WB 24.4 kbit/s	132572 1770 MHz	20 MHz	QPSK	1/0	26.3	16.92	3.39	2.90	5.20	
WB	Max - 1		LTE Band 2	Ant.A	EVS-WB 24.4 kbit/s	18900 1880 MHz	20 MHz	QPSK	1/0	26.1	16.87	3.36	3.10	6.70
NB	Max - 1			Ant.A	EVS-NB 24.4 kbit/s	18900 1880 MHz	20 MHz	QPSK	1/0	26.1	19.92	2.86	2.31	9.00
WB	Max - 1	LTE Band 4	Ant.A	EVS-WB 24.4 kbit/s	20175 1732.5 MHz	20 MHz	QPSK	1/0	26.1	16.85	3.39	3.10	7.10	
NB	Max - 1		Ant.A	EVS-NB 24.4 kbit/s	20175 1732.5 MHz	20 MHz	QPSK	1/0	26.1	19.82	2.97	2.39	9.50	
WB	Max - 1	LTE Band 5	Ant.A	EVS-WB 24.4 kbit/s	20525 836.5 MHz	10 MHz	QPSK	1/0	26.1	16.83	3.42	2.90	5.70	
NB	Max - 1		Ant.A	EVS-NB 24.4 kbit/s	20525 836.5 MHz	10 MHz	QPSK	1/0	26.1	19.85	2.76	2.31	9.60	
WB	Max - 1	LTE Band 7	Ant.A	EVS-WB 24.4 kbit/s	21100 2535 MHz	20 MHz	QPSK	1/0	26.1	16.98	2.98	2.20	6.50	
NB	Max - 1		Ant.A	EVS-NB 24.4 kbit/s	21100 2535 MHz	20 MHz	QPSK	1/0	26.1	20.11	2.57	1.82	8.80	
WB	Max - 1	LTE Band 12	Ant.A	EVS-WB 24.4 kbit/s	23095 707.5 MHz	10 MHz	QPSK	1/0	26.1	16.96	3.22	2.60	6.00	
NB	Max - 1		Ant.A	EVS-NB 24.4 kbit/s	23095 707.5 MHz	10 MHz	QPSK	1/0	26.1	20.07	2.54	2.04	9.00	
WB	Max - 1	LTE Band 13	Ant.A	EVS-WB 24.4 kbit/s	23230 782 MHz	10 MHz	QPSK	1/0	26.1	16.93	3.33	2.70	7.30	
NB	Max - 1		Ant.A	EVS-NB 24.4 kbit/s	23230 782 MHz	10 MHz	QPSK	1/0	26.1	19.96	2.74	2.22	9.20	
WB	Max - 1	LTE Band 14	Ant.A	EVS-WB 24.4 kbit/s	23330 793 MHz	10 MHz	QPSK	1/0	26.1	16.92	3.34	2.90	7.00	
NB	Max - 1		Ant.A	EVS-NB 24.4 kbit/s	23330 793 MHz	10 MHz	QPSK	1/0	26.1	19.99	2.66	2.11	9.50	
WB	Max - 1	LTE Band 25	Ant.A	EVS-WB 24.4 kbit/s	26365 1882.5 MHz	20 MHz	QPSK	1/0	26.1	16.90	3.34	2.80	7.20	
NB	Max - 1		Ant.A	EVS-NB 24.4 kbit/s	26365 1882.5 MHz	20 MHz	QPSK	1/0	26.1	20.01	2.63	2.14	8.30	
WB	Max - 1	LTE Band 26	Ant.A	EVS-WB 24.4 kbit/s	26865 831.5 MHz	15 MHz	QPSK	1/0	26.1	16.87	3.34	2.90	6.60	
NB	Max - 1		Ant.A	EVS-NB 24.4 kbit/s	26865 831.5 MHz	15 MHz	QPSK	1/0	26.1	19.95	2.70	2.32	9.50	
WB	Max - 1	LTE Band 30	Ant.A	EVS-WB 24.4 kbit/s	27710 2310 MHz	10 MHz	QPSK	1/0	26.1	16.91	3.43	3.10	5.40	
NB	Max - 1		Ant.A	EVS-NB 24.4 kbit/s	27710 2310 MHz	10 MHz	QPSK	1/0	26.1	20.00	2.66	2.04	8.70	
WB	Max - 1	LTE Band 71	Ant.A	EVS-WB 24.4 kbit/s	133297 680.5 MHz	20 MHz	QPSK	1/0	26.1	16.88	3.37	3.00	5.90	
NB	Max - 1		Ant.A	EVS-NB 24.4 kbit/s	133297 680.5 MHz	20 MHz	QPSK	1/0	26.1	19.95	2.87	2.30	9.30	

8N Mounting Force – VoLTE TDD

Codec (NB or WB)	Volume Control Level	Mode / Band	Antenna	Voice Codec / Codec bitrate (kpbs)	Channel and Frequency	Bandwidth	Waveform / Modulation	RB (Allocation/ Offset)	Volume Control Results				
									8N				
									Noise (LAF_MAX) (dBA)	Conversational Gain (dB)	Frequency Response Margin (dB)		PN-SDNR margin (dB)
FF	DF												
WB	Max - 1	LTE Band 41 PC2	Ant.A	EVS-WB 24.4 kbit/s	40620 2593 MHz	20 MHz	QPSK	1/0	26.4	16.69	3.39	3.10	5.20
WB	Max - 1		Ant.A	EVS-WB 24.4 kbit/s	40620 2593 MHz	20 MHz	QPSK	1/49	26.4	16.86	3.25	2.90	5.40
WB	Max - 1		Ant.A	EVS-WB 24.4 kbit/s	40620 2593 MHz	20 MHz	QPSK	1/99	26.4	16.89	3.26	3.00	5.70
WB	Max - 1		Ant.A	EVS-WB 24.4 kbit/s	40620 2593 MHz	20 MHz	QPSK	50/0	26.4	16.83	3.30	2.80	7.60
WB	Max - 1		Ant.A	EVS-WB 24.4 kbit/s	40620 2593 MHz	20 MHz	QPSK	50/24	26.4	16.87	3.26	2.80	5.20
WB	Max - 1		Ant.A	EVS-WB 24.4 kbit/s	40620 2593 MHz	20 MHz	QPSK	50/50	26.4	16.85	3.32	2.90	7.90
WB	Max - 1		Ant.A	EVS-WB 24.4 kbit/s	40620 2593 MHz	20 MHz	QPSK	100/0	26.4	16.86	3.36	3.00	5.90
WB	Max - 1		Ant.A	EVS-WB 24.4 kbit/s	40620 2593 MHz	20 MHz	16QAM	1/0	26.4	16.84	3.30	3.00	5.10
WB	Max - 1		Ant.A	EVS-WB 24.4 kbit/s	40620 2593 MHz	20 MHz	64QAM	1/0	26.4	16.84	3.27	3.00	5.50
WB	Max - 1		Ant.A	EVS-WB 24.4 kbit/s	40620 2593 MHz	20 MHz	256QAM	1/0	26.4	16.90	3.25	2.70	4.90
WB	Max - 1		Ant.A	EVS-WB 24.4 kbit/s	40620 2593 MHz	15 MHz	QPSK	1/0	26.4	16.90	3.36	2.80	6.00
WB	Max - 1		Ant.A	EVS-WB 24.4 kbit/s	40620 2593 MHz	10 MHz	QPSK	1/0	26.4	16.85	3.33	3.10	6.00
WB	Max - 1		Ant.A	EVS-WB 24.4 kbit/s	40620 2593 MHz	5 MHz	QPSK	1/0	26.4	16.83	3.34	3.10	5.00
WB	Max - 1		Ant.A	EVS-WB 24.4 kbit/s	39750 2506 MHz	20 MHz	QPSK	1/0	26.4	16.86	3.34	3.00	5.20
WB	Max - 1		Ant.A	EVS-WB 24.4 kbit/s	40185 2549.5 MHz	20 MHz	QPSK	1/0	26.4	16.87	3.36	3.10	6.90
WB	Max - 1		Ant.A	EVS-WB 24.4 kbit/s	41055 2636.5 MHz	20 MHz	QPSK	1/0	26.4	16.82	3.39	3.10	4.80
WB	Max - 1		Ant.A	EVS-WB 24.4 kbit/s	41490 2680 MHz	20 MHz	QPSK	1/0	26.4	16.84	3.31	3.00	4.70
WB	Max - 1		LTE Band 38	Ant.A	EVS-WB 24.4 kbit/s	38000 2595 MHz	20 MHz	QPSK	1/0	26.4	16.82	3.36	3.10
NB	Max - 1	Ant.A		EVS-NB 24.4 kbit/s	38000 2595 MHz	20 MHz	QPSK	1/0	26.4	19.92	2.55	2.11	8.50
WB	Max - 1	LTE Band 41 PC3	Ant.A	EVS-WB 24.4 kbit/s	40620 2593 MHz	20 MHz	QPSK	1/0	26.4	16.83	3.37	3.10	4.40
NB	Max - 1		Ant.A	EVS-NB 24.4 kbit/s	40620 2593 MHz	20 MHz	QPSK	1/0	26.4	19.89	2.54	2.04	8.30
WB	Max - 1	LTE Band 48	Ant.E	EVS-WB 24.4 kbit/s	55773 3603.3 MHz	20 MHz	QPSK	1/0	26.4	16.86	3.43	2.90	7.30
NB	Max - 1		Ant.E	EVS-NB 24.4 kbit/s	55773 3603.3 MHz	20 MHz	QPSK	1/0	26.4	19.87	2.64	2.21	8.80

8N Mounting Force – VoNR FDD

Codec (NB or WB)	Volume Control Level	Mode / Band	Antenna	Voice Codec / Codec bitrate (kbps)	Channel and Frequency	Bandwidth	Waveform / Modulation	RB (Allocation/ Offset)	Volume Control Results					
									8N					
									Noise (LAF_MAX) (dBA)	Conversational Gain (dB)	Frequency Response Margin (dB)		PN-SDNR margin (dB)	
FF	DF													
WB	Max - 1	NR Band n66	Ant.A	EVS-WB 24.4 kbit/s	349000 1745.00 MHz	40 MHz	DFT-s-OFDM QPSK	1/1	27.5	16.88	3.48	2.90	6.20	
WB	Max - 1		Ant.B	EVS-WB 24.4 kbit/s	349000 1745.00 MHz	40 MHz	DFT-s-OFDM QPSK	1/1	27.5	16.95	3.56	3.30	5.20	
WB	Max - 1		Ant.A	EVS-WB 24.4 kbit/s	349000 1745.00 MHz	40 MHz	DFT-s-OFDM QPSK	1/107	27.5	16.97	3.43	3.10	7.00	
WB	Max - 1		Ant.A	EVS-WB 24.4 kbit/s	349000 1745.00 MHz	40 MHz	DFT-s-OFDM QPSK	1/214	27.5	16.98	3.47	3.20	4.90	
WB	Max - 1		Ant.A	EVS-WB 24.4 kbit/s	349000 1745.00 MHz	40 MHz	DFT-s-OFDM QPSK	108/0	27.5	16.95	3.49	3.20	4.40	
WB	Max - 1		Ant.A	EVS-WB 24.4 kbit/s	349000 1745.00 MHz	40 MHz	DFT-s-OFDM QPSK	108/54	27.5	16.93	3.50	3.20	2.80	
WB	Max - 1		Ant.A	EVS-WB 24.4 kbit/s	349000 1745.00 MHz	40 MHz	DFT-s-OFDM QPSK	108/108	27.5	16.97	3.53	3.30	2.90	
WB	Max - 1		Ant.A	EVS-WB 24.4 kbit/s	349000 1745.00 MHz	40 MHz	DFT-s-OFDM QPSK	216/0	27.5	16.92	3.51	3.20	7.00	
WB	Max - 1		Ant.A	EVS-WB 24.4 kbit/s	349000 1745.00 MHz	40 MHz	DFT-s-OFDM plv2 BPSK	1/1	27.5	16.96	3.46	3.20	8.10	
WB	Max - 1		Ant.A	EVS-WB 24.4 kbit/s	349000 1745.00 MHz	40 MHz	DFT-s-OFDM 16QAM	1/1	27.5	16.92	3.45	3.20	5.40	
WB	Max - 1		Ant.A	EVS-WB 24.4 kbit/s	349000 1745.00 MHz	40 MHz	DFT-s-OFDM 64QAM	1/1	27.5	16.96	3.52	3.30	5.80	
WB	Max - 1		Ant.A	EVS-WB 24.4 kbit/s	349000 1745.00 MHz	40 MHz	DFT-s-OFDM 256QAM	1/1	27.5	16.9	3.53	3.20	6.50	
WB	Max - 1		Ant.A	EVS-WB 24.4 kbit/s	349000 1745.00 MHz	40 MHz	CP-OFDM QPSK	1/1	27.1	16.9	3.42	3.10	8.20	
WB	Max - 1		Ant.A	EVS-WB 24.4 kbit/s	349000 1745.00 MHz	40 MHz	CP-OFDM QPSK	1/107	27.1	16.91	3.45	3.20	8.20	
WB	Max - 1		Ant.A	EVS-WB 24.4 kbit/s	349000 1745.00 MHz	40 MHz	CP-OFDM QPSK	1/214	27.1	16.91	3.50	3.30	8.20	
WB	Max - 1		Ant.A	EVS-WB 24.4 kbit/s	349000 1745.00 MHz	40 MHz	CP-OFDM QPSK	108/0	27.1	16.94	3.54	3.30	8.10	
WB	Max - 1		Ant.A	EVS-WB 24.4 kbit/s	349000 1745.00 MHz	40 MHz	CP-OFDM QPSK	108/54	27.1	16.92	3.50	3.20	7.70	
WB	Max - 1		Ant.A	EVS-WB 24.4 kbit/s	349000 1745.00 MHz	40 MHz	CP-OFDM QPSK	108/108	27.1	16.93	3.48	3.20	7.90	
WB	Max - 1		Ant.A	EVS-WB 24.4 kbit/s	349000 1745.00 MHz	40 MHz	CP-OFDM QPSK	216/0	27.1	16.92	3.46	3.20	7.60	
WB	Max - 1		Ant.A	EVS-WB 24.4 kbit/s	349000 1745.00 MHz	40 MHz	CP-OFDM 16QAM	1/1	27.1	16.93	3.48	3.20	8.20	
WB	Max - 1		Ant.A	EVS-WB 24.4 kbit/s	349000 1745.00 MHz	40 MHz	CP-OFDM 64QAM	1/1	27.1	16.95	3.58	3.30	8.20	
WB	Max - 1		Ant.A	EVS-WB 24.4 kbit/s	349000 1745.00 MHz	40 MHz	CP-OFDM 256QAM	1/1	27.1	16.91	3.61	3.30	7.60	
WB	Max - 1		Ant.A	EVS-WB 24.4 kbit/s	349000 1745.00 MHz	30 MHz	DFT-s-OFDM QPSK	1/1	27.1	16.94	3.54	3.30	8.50	
WB	Max - 1		Ant.A	EVS-WB 24.4 kbit/s	349000 1745.00 MHz	25 MHz	DFT-s-OFDM QPSK	1/1	27.1	16.93	3.55	3.30	8.20	
WB	Max - 1		Ant.A	EVS-WB 24.4 kbit/s	349000 1745.00 MHz	20 MHz	DFT-s-OFDM QPSK	1/1	27.1	16.92	3.61	3.30	6.40	
WB	Max - 1		Ant.A	EVS-WB 24.4 kbit/s	349000 1745.00 MHz	15 MHz	DFT-s-OFDM QPSK	1/1	27.1	16.91	3.56	3.30	6.70	
WB	Max - 1		Ant.A	EVS-WB 24.4 kbit/s	349000 1745.00 MHz	10 MHz	DFT-s-OFDM QPSK	1/1	27.1	16.93	3.55	3.30	6.90	
WB	Max - 1		Ant.A	EVS-WB 24.4 kbit/s	349000 1745.00 MHz	5 MHz	DFT-s-OFDM QPSK	1/1	27.1	16.91	3.57	3.30	7.20	
WB	Max - 1		Ant.A	EVS-WB 24.4 kbit/s	346000 1730.00 MHz	40 MHz	DFT-s-OFDM QPSK	1/1	27.5	16.92	3.41	3.10	5.30	
WB	Max - 1		Ant.A	EVS-WB 24.4 kbit/s	352000 1760.00 MHz	40 MHz	DFT-s-OFDM QPSK	1/1	27.5	16.9	3.45	3.20	5.80	
WB	Max - 1		NR Band n2	Ant.A	EVS-WB 24.4 kbit/s	376000 1880.00 MHz	40 MHz	DFT-s-OFDM QPSK	1/1	27.1	16.89	3.56	3.30	8.30
NB	Max - 1			Ant.A	EVS-NB 24.4 kbit/s	376000 1880.00 MHz	40 MHz	DFT-s-OFDM QPSK	1/1	27.1	19.29	2.81	2.46	10.30
WB	Max - 1	NR Band n5	Ant.A	EVS-WB 24.4 kbit/s	167300 836.50 MHz	20 MHz	DFT-s-OFDM QPSK	1/1	27.1	16.95	3.53	3.20	7.90	
NB	Max - 1		Ant.A	EVS-NB 24.4 kbit/s	167300 836.50 MHz	20 MHz	DFT-s-OFDM QPSK	1/1	27.1	19.31	2.86	2.41	9.40	
WB	Max - 1	NR Band n25	Ant.A	EVS-WB 24.4 kbit/s	376500 1882.5 MHz	40 MHz	DFT-s-OFDM QPSK	1/1	27.1	16.92	3.54	3.30	7.00	
NB	Max - 1		Ant.A	EVS-NB 24.4 kbit/s	376500 1882.5 MHz	40 MHz	DFT-s-OFDM QPSK	1/1	27.1	19.29	2.85	2.53	10.60	
WB	Max - 1	NR Band n30	Ant.A	EVS-WB 24.4 kbit/s	462000 2310 MHz	10 MHz	DFT-s-OFDM QPSK	1/1	27.1	16.92	3.60	3.30	8.20	
NB	Max - 1		Ant.A	EVS-NB 24.4 kbit/s	462000 2310 MHz	10 MHz	DFT-s-OFDM QPSK	1/1	27.1	19.27	2.88	2.52	9.30	
WB	Max - 1	NR Band n70	Ant.A	EVS-WB 24.4 kbit/s	340500 1702.5 MHz	15 MHz	DFT-s-OFDM QPSK	1/1	27.1	16.93	3.51	3.20	8.40	
NB	Max - 1		Ant.A	EVS-NB 24.4 kbit/s	340500 1702.5 MHz	15 MHz	DFT-s-OFDM QPSK	1/1	27.1	19.23	2.90	2.47	9.40	
WB	Max - 1	NR Band n71	Ant.A	EVS-WB 24.4 kbit/s	136100 680.5 MHz	20 MHz	DFT-s-OFDM QPSK	1/1	27.1	16.91	3.52	3.30	8.50	
NB	Max - 1		Ant.A	EVS-NB 24.4 kbit/s	136100 680.5 MHz	20 MHz	DFT-s-OFDM QPSK	1/1	27.1	19.27	2.81	2.33	9.90	

8N Mounting Force – VoNR TDD

Codec (NB or WB)	Volume Control Level	Mode / Band	Antenna	Voice Codec / Codec bitrate (kpbs)	Channel and Frequency	Bandwidth	Waveform / Modulation	RB (Allocation/ Offset)	Volume Control Results				
									8N				PN-SDNR margin (dB)
									Noise (LAF_MAX) (dBA)	Conversational Gain (dB)	Frequency Response Margin (dB)		
FF	DF												
WB	Max - 1	NR Band n77 HPUE	Ant.E	EVS-WB 24.4 kbit/s	65000 3750 MHz	100 MHz	DFT-s-OFDM QPSK	1/1	26.5	16.85	3.47	3.10	8.10
WB	Max - 1		Ant.E	EVS-WB 24.4 kbit/s	65000 3750 MHz	100 MHz	DFT-s-OFDM QPSK	1/136	26.5	16.94	3.49	3.10	8.00
WB	Max - 1		Ant.E	EVS-WB 24.4 kbit/s	65000 3750 MHz	100 MHz	DFT-s-OFDM QPSK	1/271	26.5	16.94	3.50	3.10	8.20
WB	Max - 1		Ant.E	EVS-WB 24.4 kbit/s	65000 3750 MHz	100 MHz	DFT-s-OFDM QPSK	135/0	26.5	16.93	3.45	3.10	7.40
WB	Max - 1		Ant.E	EVS-WB 24.4 kbit/s	65000 3750 MHz	100 MHz	DFT-s-OFDM QPSK	135/69	26.5	16.96	3.47	2.90	8.10
WB	Max - 1		Ant.E	EVS-WB 24.4 kbit/s	65000 3750 MHz	100 MHz	DFT-s-OFDM QPSK	135/138	26.5	16.91	3.58	3.00	8.00
WB	Max - 1		Ant.E	EVS-WB 24.4 kbit/s	65000 3750 MHz	100 MHz	DFT-s-OFDM QPSK	270/0	26.5	16.95	3.46	2.90	8.40
WB	Max - 1		Ant.E	EVS-WB 24.4 kbit/s	65000 3750 MHz	100 MHz	DFT-s-OFDM pi/2 BPSK	1/1	26.5	16.92	3.45	3.10	8.20
WB	Max - 1		Ant.E	EVS-WB 24.4 kbit/s	65000 3750 MHz	100 MHz	DFT-s-OFDM 16QAM	1/1	26.5	16.94	3.51	3.30	7.90
WB	Max - 1		Ant.E	EVS-WB 24.4 kbit/s	65000 3750 MHz	100 MHz	DFT-s-OFDM 64QAM	1/1	26.5	16.95	3.54	3.30	8.00
WB	Max - 1		Ant.E	EVS-WB 24.4 kbit/s	65000 3750 MHz	100 MHz	DFT-s-OFDM 256QAM	1/1	26.5	16.92	3.38	3.00	4.80
WB	Max - 1		Ant.E	EVS-WB 24.4 kbit/s	65000 3750 MHz	100 MHz	CP-OFDM QPSK	1/1	26.5	16.89	3.52	3.30	8.30
WB	Max - 1		Ant.E	EVS-WB 24.4 kbit/s	65000 3750 MHz	100 MHz	CP-OFDM QPSK	1/136	26.5	16.91	3.53	3.20	8.00
WB	Max - 1		Ant.E	EVS-WB 24.4 kbit/s	65000 3750 MHz	100 MHz	CP-OFDM QPSK	1/271	26.5	16.95	3.47	3.20	7.60
WB	Max - 1		Ant.E	EVS-WB 24.4 kbit/s	65000 3750 MHz	100 MHz	CP-OFDM QPSK	135/0	26.5	16.91	3.49	3.20	8.10
WB	Max - 1		Ant.E	EVS-WB 24.4 kbit/s	65000 3750 MHz	100 MHz	CP-OFDM QPSK	135/69	26.5	16.92	3.48	3.20	6.50
WB	Max - 1		Ant.E	EVS-WB 24.4 kbit/s	65000 3750 MHz	100 MHz	CP-OFDM QPSK	135/138	26.5	16.89	3.52	3.10	5.00
WB	Max - 1		Ant.E	EVS-WB 24.4 kbit/s	65000 3750 MHz	100 MHz	CP-OFDM QPSK	270/0	26.5	16.91	3.49	3.20	8.30
WB	Max - 1		Ant.E	EVS-WB 24.4 kbit/s	65000 3750 MHz	100 MHz	CP-OFDM 16QAM	1/1	26.5	16.93	3.49	3.20	7.30
WB	Max - 1		Ant.E	EVS-WB 24.4 kbit/s	65000 3750 MHz	100 MHz	CP-OFDM 64QAM	1/1	26.5	16.92	3.46	3.20	8.30
WB	Max - 1		Ant.E	EVS-WB 24.4 kbit/s	65000 3750 MHz	100 MHz	CP-OFDM 256QAM	1/1	26.5	16.94	3.53	3.30	6.80
WB	Max - 1		Ant.E	EVS-WB 24.4 kbit/s	65000 3750 MHz	90 MHz	DFT-s-OFDM QPSK	1/1	26.5	16.93	3.55	3.10	5.20
WB	Max - 1		Ant.E	EVS-WB 24.4 kbit/s	65000 3750 MHz	80 MHz	DFT-s-OFDM QPSK	1/1	26.5	16.90	3.50	3.20	7.10
WB	Max - 1		Ant.E	EVS-WB 24.4 kbit/s	65000 3750 MHz	70 MHz	DFT-s-OFDM QPSK	1/1	26.5	16.90	3.47	3.20	7.40
WB	Max - 1		Ant.E	EVS-WB 24.4 kbit/s	65000 3750 MHz	60 MHz	DFT-s-OFDM QPSK	1/1	26.5	16.93	3.49	3.20	6.80
WB	Max - 1		Ant.E	EVS-WB 24.4 kbit/s	65000 3750 MHz	50 MHz	DFT-s-OFDM QPSK	1/1	26.5	16.93	3.45	3.10	6.20
WB	Max - 1		Ant.E	EVS-WB 24.4 kbit/s	65000 3750 MHz	40 MHz	DFT-s-OFDM QPSK	1/1	26.5	16.94	3.45	3.10	5.20
WB	Max - 1		Ant.E	EVS-WB 24.4 kbit/s	65000 3750 MHz	30 MHz	DFT-s-OFDM QPSK	1/1	26.5	16.87	3.50	3.30	6.30
WB	Max - 1		Ant.E	EVS-WB 24.4 kbit/s	65000 3750 MHz	25 MHz	DFT-s-OFDM QPSK	1/1	26.5	16.90	3.47	3.10	8.30
WB	Max - 1		Ant.E	EVS-WB 24.4 kbit/s	65000 3750 MHz	20 MHz	DFT-s-OFDM QPSK	1/1	26.5	16.94	3.53	3.20	5.90
WB	Max - 1	Ant.E	EVS-WB 24.4 kbit/s	65000 3750 MHz	15 MHz	DFT-s-OFDM QPSK	1/1	26.5	16.91	3.58	3.20	6.70	
WB	Max - 1	Ant.E	EVS-WB 24.4 kbit/s	65000 3750 MHz	10 MHz	DFT-s-OFDM QPSK	1/1	26.5	16.90	3.50	3.20	5.90	
WB	Max - 1	Ant.E	EVS-WB 24.4 kbit/s	633334 3500.01 MHz	100 MHz	DFT-s-OFDM QPSK	1/1	26.5	16.91	3.46	3.10	7.00	
WB	Max - 1	Ant.E	EVS-WB 24.4 kbit/s	662000 3930 MHz	100 MHz	DFT-s-OFDM QPSK	1/1	26.5	16.90	3.44	3.20	8.10	
WB	Max - 1	NR Band n41 HPUE	Ant.LA	EVS-WB 24.4 kbit/s	518598 2592.99 MHz	100 MHz	DFT-s-OFDM QPSK	1/1	26.5	16.88	3.51	3.20	8.20
NB	Max - 1		Ant.LA	EVS-NB 24.4 kbit/s	518598 2592.99 MHz	100 MHz	DFT-s-OFDM QPSK	1/1	26.5	19.60	2.30	1.91	8.80
WB	Max - 1	NR Band n48	Ant.E	EVS-WB 24.4 kbit/s	641666 3624.99 MHz	40 MHz	DFT-s-OFDM QPSK	1/1	26.5	16.89	3.58	3.10	6.70
NB	Max - 1		Ant.E	EVS-NB 24.4 kbit/s	641666 3624.99 MHz	40 MHz	DFT-s-OFDM QPSK	1/1	26.5	19.58	2.15	1.91	9.50
WB	Max - 1	NR Band n78 HPUE	Ant.E	EVS-WB 24.4 kbit/s	650000 3750 MHz	100 MHz	DFT-s-OFDM QPSK	1/1	26.5	16.94	3.52	3.20	8.30
NB	Max - 1		Ant.E	EVS-WB 24.4 kbit/s	650000 3750 MHz	100 MHz	DFT-s-OFDM QPSK	1/1	26.5	19.58	2.31	2.06	9.80

8N Mounting Force – VoWiFi 2.4GHz

Codec (NB or WB)	Volume Control Level	Mode / Band	Antenna	Voice Codec / Codec bitrate (kbps)	Channel and Frequency	Bandwidth	Waveform / Modulation	RB (Allocation/ Offset)	Volume Control Results				
									8N				
									Noise (LAF_MAX) (dBA)	Conversational Gain (dB)	Frequency Response Margin (dB)		PN-SDNR margin (dB)
FF	DF												
WB	Max - 1	WiFi 2.4GHz 802.11b	Ant.D	EVS-WB 24.4 kbit/s	CH.6 2437 MHz	20 MHz	DSSS 1 Mbps	N/A	26.5	16.70	2.95	2.40	8.00
WB	Max - 1		Ant.D	EVS-WB 24.4 kbit/s	CH.6 2437 MHz	20 MHz	CCK 5.5 Mbps	N/A	26.5	16.79	3.11	2.30	6.50
WB	Max - 1		Ant.D	EVS-WB 24.4 kbit/s	CH.6 2437 MHz	20 MHz	CCK 11 Mbps	N/A	26.5	16.81	3.19	2.40	7.90
WB	Max - 1		Ant.D	EVS-WB 24.4 kbit/s	CH.1 2412 MHz	20 MHz	DSSS 1 Mbps	N/A	26.5	16.77	3.01	2.80	7.30
WB	Max - 1		Ant.D	EVS-WB 24.4 kbit/s	CH.11 2462 MHz	20 MHz	DSSS 1 Mbps	N/A	26.5	16.79	2.55	2.30	5.60
WB	Max - 1	WiFi 2.4GHz 802.11g	Ant.D	EVS-WB 24.4 kbit/s	CH.6 2437 MHz	20 MHz	BPSK 6 Mbps	N/A	26.5	16.76	3.06	2.50	8.00
NB	Max - 1		Ant.D	EVS-NB 24.4 kbit/s	CH.6 2437 MHz	20 MHz	BPSK 6 Mbps	N/A	26.5	19.98	2.19	1.67	9.70
WB	Max - 1	WiFi 2.4GHz 802.11n HT20	Ant.D	EVS-WB 24.4 kbit/s	CH.6 2437 MHz	20 MHz	MCS 0 6.5 Mbps	N/A	26.5	16.75	3.22	2.30	8.00
NB	Max - 1		Ant.D	EVS-NB 24.4 kbit/s	CH.6 2437 MHz	20 MHz	MCS 0 6.5 Mbps	N/A	26.5	20.01	2.26	1.78	9.40

8N Mounting Force – VoWiFi U-NII

Codec (NB or WB)	Volume Control Level	Mode / Band	Antenna	Voice Codec / Codec bitrate (kbps)	Channel and Frequency	Bandwidth	Waveform / Modulation	RB (Allocation/ Offset)	Volume Control Results				
									8N				
									Noise (LAF_MAX) (dBA)	Conversational Gain (dB)	Frequency Response Margin (dB)		PN-SDNR margin (dB)
FF	DF												
WB	Max - 1	WiFi 5GHz 802.11a U-NII-1	Ant.D	EVS-WB 24.4 kbit/s	CH.40 5200 MHz	20 MHz	BPSK 6 Mbps	N/A	26.2	16.83	3.26	2.60	4.70
WB	Max - 1		Ant.D	EVS-WB 24.4 kbit/s	CH.40 5200 MHz	20 MHz	QPSK 18 Mbps	N/A	26.2	16.84	3.20	2.60	5.30
WB	Max - 1		Ant.D	EVS-WB 24.4 kbit/s	CH.40 5200 MHz	20 MHz	64QAM 54 Mbps	N/A	26.2	16.85	3.18	2.30	5.00
WB	Max - 1		Ant.D	EVS-WB 24.4 kbit/s	CH.36 5180 MHz	20 MHz	BPSK 6 Mbps	N/A	26.2	16.85	2.82	2.20	7.50
WB	Max - 1		Ant.D	EVS-WB 24.4 kbit/s	CH.48 5240 MHz	20 MHz	BPSK 6 Mbps	N/A	26.2	16.85	3.09	2.40	4.30
WB	Max - 1	WiFi 5GHz 802.11n HT20 U-NII-1	Ant.D	EVS-WB 24.4 kbit/s	CH.40 5200 MHz	20 MHz	MCS 0 6.5 Mbps	N/A	26.2	16.81	3.13	2.30	5.60
WB	Max - 1		Ant.D	EVS-WB 24.4 kbit/s	CH.40 5200 MHz	20 MHz	MCS 3 26 Mbps	N/A	26.2	16.84	3.06	2.60	6.30
WB	Max - 1		Ant.D	EVS-WB 24.4 kbit/s	CH.40 5200 MHz	20 MHz	MCS 7 65 Mbps	N/A	26.2	16.86	2.73	2.30	7.50
NB	Max - 1		Ant.D	EVS-NB 24.4 kbit/s	CH.40 5200 MHz	20 MHz	MCS 0 6.5 Mbps	N/A	26.2	20.06	2.19	1.62	8.60
WB	Max - 1	WiFi 5GHz 802.11n HT40 U-NII-1	Ant.D	EVS-WB 24.4 kbit/s	CH.38 5190 MHz	40 MHz	MCS 0 6.5 Mbps	N/A	26.2	16.83	3.05	2.50	7.80
WB	Max - 1		Ant.D	EVS-WB 24.4 kbit/s	CH.38 5190 MHz	40 MHz	MCS 3 54 Mbps	N/A	26.2	16.86	3.00	2.50	5.80
WB	Max - 1		Ant.D	EVS-WB 24.4 kbit/s	CH.38 5190 MHz	40 MHz	MCS 7 135 Mbps	N/A	26.2	16.86	2.94	2.50	5.10
NB	Max - 1		Ant.D	EVS-NB 24.4 kbit/s	CH.38 5190 MHz	40 MHz	MCS 0 13.5 Mbps	N/A	26.2	20.07	2.17	1.72	10.00
WB	Max - 1	WiFi 5GHz 802.11ac VHT20 U-NII-1	Ant.D	EVS-WB 24.4 kbit/s	CH.40 5200 MHz	20 MHz	MCS 0 6.5 Mbps	N/A	26.2	16.78	2.95	2.30	7.40
WB	Max - 1		Ant.D	EVS-WB 24.4 kbit/s	CH.40 5200 MHz	20 MHz	MCS 4 39 Mbps	N/A	26.2	16.83	3.21	2.50	6.70
WB	Max - 1		Ant.D	EVS-WB 24.4 kbit/s	CH.40 5200 MHz	20 MHz	MCS 8 78 Mbps	N/A	26.2	16.85	2.90	2.40	6.90
NB	Max - 1		Ant.D	EVS-NB 24.4 kbit/s	CH.40 5200 MHz	20 MHz	MCS 0 6.5 Mbps	N/A	26.2	20.06	2.20	1.53	8.80
WB	Max - 1	WiFi 5GHz 802.11ac VHT40 U-NII-1	Ant.D	EVS-WB 24.4 kbit/s	CH.38 5190 MHz	40 MHz	MCS 0 13.5 Mbps	N/A	26.2	16.81	2.97	2.60	7.00
WB	Max - 1		Ant.D	EVS-WB 24.4 kbit/s	CH.38 5190 MHz	40 MHz	MCS 4 108 Mbps	N/A	26.2	16.85	3.21	2.40	8.30
WB	Max - 1		Ant.D	EVS-WB 24.4 kbit/s	CH.38 5190 MHz	40 MHz	MCS 9 180 Mbps	N/A	26.2	16.88	3.25	2.40	6.20
NB	Max - 1		Ant.D	EVS-NB 24.4 kbit/s	CH.38 5190 MHz	40 MHz	MCS 0 13.5 Mbps	N/A	26.2	20.03	2.15	1.54	8.50
WB	Max - 1	WiFi 5GHz 802.11ac VHT80 U-NII-1	Ant.D	EVS-WB 24.4 kbit/s	CH.42 5210 MHz	80 MHz	MCS 0 29.3 Mbps	N/A	26.2	16.79	3.22	2.40	8.10
WB	Max - 1		Ant.D	EVS-WB 24.4 kbit/s	CH.42 5210 MHz	80 MHz	MCS 4 175.5 Mbps	N/A	26.2	16.85	3.12	2.30	7.60
WB	Max - 1		Ant.D	EVS-WB 24.4 kbit/s	CH.42 5210 MHz	80 MHz	MCS 9 390 Mbps	N/A	26.2	16.85	2.91	2.50	7.10
NB	Max - 1		Ant.D	EVS-NB 24.4 kbit/s	CH.42 5210 MHz	80 MHz	MCS 9 390 Mbps	N/A	26.2	20.05	2.15	1.60	9.10
WB	Max - 1	WiFi 5GHz 802.11ac VHT20 U-NII-2A	Ant.D	EVS-WB 24.4 kbit/s	CH.56 5280 MHz	20 MHz	MCS 0 6.5 Mbps	N/A	26.2	16.80	2.86	2.30	7.20
NB	Max - 1		Ant.D	EVS-NB 24.4 kbit/s	CH.56 5280 MHz	20 MHz	MCS 0 6.5 Mbps	N/A	26.2	20.04	2.06	1.45	7.70
WB	Max - 1	WiFi 5GHz 802.11ac VHT20 U-NII-2C	Ant.D	EVS-WB 24.4 kbit/s	CH.120 5600 MHz	20 MHz	MCS 0 6.5 Mbps	N/A	26.2	16.82	2.97	2.40	7.90
NB	Max - 1		Ant.D	EVS-NB 24.4 kbit/s	CH.120 5600 MHz	20 MHz	MCS 0 6.5 Mbps	N/A	26.2	20.05	2.12	1.56	8.80
WB	Max - 1	WiFi 5GHz 802.11ac VHT20 U-NII-3	Ant.D	EVS-WB 24.4 kbit/s	CH.157 5785 MHz	20 MHz	MCS 0 6.5 Mbps	N/A	26.2	16.81	3.03	2.50	7.50
NB	Max - 1		Ant.D	EVS-NB 24.4 kbit/s	CH.157 5785 MHz	20 MHz	MCS 0 6.5 Mbps	N/A	26.2	20.10	2.04	1.42	9.30

9.3. Other Voice Codecs Investigation for GSM/WCDMA/VoLTE/VoNR/VoWiFi

An investigation between the various other voice codecs configurations (Low/Mid/High bit rates for Narrowband and Wideband) and conversational gain is documented to evaluate conversational gain for each voice service type. The table below compares the varying codec configurations.

A codec investigation was performed of each GSM, W-CDMA, LTE FDD/TDD, NR FDD/TDD and VoWiFi.

2N Mounting Force

Codec (NB or WB)	Volume Control Level	Mode / Band	Antenna	Voice Codec / Codec bitrate (kbps)	Channel and Frequency	Bandwidth	Waveform / Modulation	RB (Allocation/ Offset)	Volume Control Results					
									2N					
									Noise (LAF_MAX) (dBA)	Conversational Gain (dB)	Frequency Response Margin (dB)		PN-SDNR margin (dB)	
FF	DF													
NB	Max - 1	GSM 850	AntA	FR V1	190 836.6 MHz	N/A	N/A	N/A	22.6	16.57	N/A	N/A	N/A	
NB	Max - 1		AntA	FR V2	190 836.6 MHz	N/A	N/A	N/A	22.6	16.97	N/A	N/A	N/A	
NB	Max - 1		AntA	HR V1	190 836.6 MHz	N/A	N/A	N/A	22.6	17.12	N/A	N/A	N/A	
NB	Max - 1	GSM 1900	AntA	FR V1	661 1880 MHz	N/A	N/A	N/A	22.6	16.41	N/A	N/A	N/A	
NB	Max - 1	WCDMA Band V	AntA	AMR-NB 4.75 kbps	4183 836.6 MHz	N/A	N/A	N/A	22.6	16.10	N/A	N/A	N/A	
NB	Max - 1		AntA	AMR-NB 7.4 kbps	4183 836.6 MHz	N/A	N/A	N/A	22.6	16.71	N/A	N/A	N/A	
NB	Max - 1		AntA	AMR-NB 12.2 kbps	4183 836.6 MHz	N/A	N/A	N/A	22.6	16.92	N/A	N/A	N/A	
WB	Max - 1		AntA	AMR-WB 6.6 kbps	4183 836.6 MHz	N/A	N/A	N/A	22.6	13.29	N/A	N/A	N/A	
WB	Max - 1		AntA	AMR-WB 12.65 kbps	4183 836.6 MHz	N/A	N/A	N/A	22.6	13.42	N/A	N/A	N/A	
WB	Max - 1		AntA	AMR-WB 23.85 kbps	4183 836.6 MHz	N/A	N/A	N/A	22.6	13.46	N/A	N/A	N/A	
WB	Max - 1		AntA	AMR-WB 6.6 kbps	9400 1880.0 MHz	N/A	N/A	N/A	22.6	13.24	N/A	N/A	N/A	
WB	Max - 1	WCDMA Band IV	AntA	AMR-WB 6.6 kbps	1413 1732.6 MHz	N/A	N/A	N/A	22.6	13.28	N/A	N/A	N/A	
NB	Max - 1	LTE Band 66	AntA	AMR-NB 4.75 kbps	132322 1745 MHz	20 MHz	QPSK	1/0	22.6	16.00	N/A	N/A	N/A	
NB	Max - 1		AntA	AMR-NB 7.4 kbps	132322 1745 MHz	20 MHz	QPSK	1/0	22.6	16.56	N/A	N/A	N/A	
NB	Max - 1		AntA	AMR-NB 12.2 kbps	132322 1745 MHz	20 MHz	QPSK	1/0	22.6	16.85	N/A	N/A	N/A	
WB	Max - 1		AntA	AMR-WB 6.6 kbps	132322 1745 MHz	20 MHz	QPSK	1/0	22.6	13.30	N/A	N/A	N/A	
WB	Max - 1		AntA	AMR-WB 12.65 kbps	132322 1745 MHz	20 MHz	QPSK	1/0	22.6	13.38	N/A	N/A	N/A	
WB	Max - 1		AntA	AMR-WB 23.85 kbps	132322 1745 MHz	20 MHz	QPSK	1/0	22.6	13.50	N/A	N/A	N/A	
NB	Max - 1		AntA	EVS-NB 5.9 kbps	132322 1745 MHz	20 MHz	QPSK	1/0	22.6	16.11	N/A	N/A	N/A	
NB	Max - 1		AntA	EVS-NB 13.2 kbps	132322 1745 MHz	20 MHz	QPSK	1/0	22.6	16.22	N/A	N/A	N/A	
WB	Max - 1		AntA	EVS-WB 5.9 kbps	132322 1745 MHz	20 MHz	QPSK	1/0	22.6	13.21	N/A	N/A	N/A	
WB	Max - 1		AntA	EVS-WB 16.4 kbps	132322 1745 MHz	20 MHz	QPSK	1/0	22.6	13.42	N/A	N/A	N/A	
NB	Max - 1		LTE Band 41 PC2	AntA	AMR-NB 4.75 kbps	40620 2593 MHz	20 MHz	QPSK	1/0	22.6	16.05	N/A	N/A	N/A
NB	Max - 1			AntA	AMR-NB 7.4 kbps	40620 2593 MHz	20 MHz	QPSK	1/0	22.6	16.54	N/A	N/A	N/A
NB	Max - 1			AntA	AMR-NB 12.2 kbps	40620 2593 MHz	20 MHz	QPSK	1/0	22.6	16.79	N/A	N/A	N/A
WB	Max - 1			AntA	AMR-WB 6.6 kbps	40620 2593 MHz	20 MHz	QPSK	1/0	22.6	13.24	N/A	N/A	N/A
WB	Max - 1	AntA		AMR-WB 12.65 kbps	40620 2593 MHz	20 MHz	QPSK	1/0	22.6	13.39	N/A	N/A	N/A	
WB	Max - 1	AntA		AMR-WB 23.85 kbps	40620 2593 MHz	20 MHz	QPSK	1/0	22.6	13.48	N/A	N/A	N/A	
NB	Max - 1	AntA		EVS-NB 5.9 kbps	40620 2593 MHz	20 MHz	QPSK	1/0	22.6	16.10	N/A	N/A	N/A	
NB	Max - 1	AntA		EVS-NB 13.2 kbps	40620 2593 MHz	20 MHz	QPSK	1/0	22.6	16.30	N/A	N/A	N/A	
WB	Max - 1	AntA		EVS-WB 5.9 kbps	40620 2593 MHz	20 MHz	QPSK	1/0	22.6	13.30	N/A	N/A	N/A	
WB	Max - 1	AntA		EVS-WB 16.4 kbps	40620 2593 MHz	20 MHz	QPSK	1/0	22.6	13.43	N/A	N/A	N/A	

2N Mounting Force (Continued)

Codec (NB or WB)	Volume Control Level	Mode / Band	Antenna	Voice Codec / Codec bitrate (kbps)	Channel and Frequency	Bandwidth	Waveform/ Modulation	RB (Allocation/ Offset)	Volume Control Results				
									2N				
									Noise (LAF_MAX) (dBA)	Conversational Gain (dB)	Frequency Response Margin (dB)		PN-SDNR margin (dB)
											FF	DF	
NB	Max - 1	NR Band n66	Ant.A	AMR-NB 4.75 kbps	349000 1745.00 MHz	40 MHz	DFT-s-OFDM QPSK	1/1	27.1	14.54	N/A	N/A	N/A
NB	Max - 1		Ant.A	AMR-NB 7.4 kbps	349000 1745.00 MHz	40 MHz	DFT-s-OFDM QPSK	1/1	27.1	15.04	N/A	N/A	N/A
NB	Max - 1		Ant.A	AMR-NB 12.2 kbps	349000 1745.00 MHz	40 MHz	DFT-s-OFDM QPSK	1/1	27.1	15.23	N/A	N/A	N/A
WB	Max - 1		Ant.A	AMR-WB 6.6 kbps	349000 1745.00 MHz	40 MHz	DFT-s-OFDM QPSK	1/1	27.1	12.63	N/A	N/A	N/A
WB	Max - 1		Ant.A	AMR-WB 12.65 kbps	349000 1745.00 MHz	40 MHz	DFT-s-OFDM QPSK	1/1	27.1	12.81	N/A	N/A	N/A
WB	Max - 1		Ant.A	AMR-WB 23.85 kbps	349000 1745.00 MHz	40 MHz	DFT-s-OFDM QPSK	1/1	27.1	12.83	N/A	N/A	N/A
NB	Max - 1		Ant.A	EVS-NB 5.9 kbps	349000 1745.00 MHz	40 MHz	DFT-s-OFDM QPSK	1/1	27.1	14.71	N/A	N/A	N/A
NB	Max - 1		Ant.A	EVS-NB 13.2 kbps	349000 1745.00 MHz	40 MHz	DFT-s-OFDM QPSK	1/1	27.1	15.24	N/A	N/A	N/A
WB	Max - 1		Ant.A	EVS-WB 5.9 kbps	349000 1745.00 MHz	40 MHz	DFT-s-OFDM QPSK	1/1	27.1	12.53	N/A	N/A	N/A
WB	Max - 1		Ant.A	EVS-WB 16.4 kbps	349000 1745.00 MHz	40 MHz	DFT-s-OFDM QPSK	1/1	27.1	12.75	N/A	N/A	N/A
NB	Max - 1	NR Band n77 HPUE	Ant.E	AMR-NB 4.75 kbps	650000 3750 MHz	100 MHz	DFT-s-OFDM QPSK	1/1	26.9	14.87	N/A	N/A	N/A
NB	Max - 1		Ant.E	AMR-NB 7.4 kbps	650000 3750 MHz	100 MHz	DFT-s-OFDM QPSK	1/1	26.9	15.45	N/A	N/A	N/A
NB	Max - 1		Ant.E	AMR-NB 12.2 kbps	650000 3750 MHz	100 MHz	DFT-s-OFDM QPSK	1/1	26.9	15.67	N/A	N/A	N/A
WB	Max - 1		Ant.E	AMR-WB 6.6 kbps	650000 3750 MHz	100 MHz	DFT-s-OFDM QPSK	1/1	26.9	12.73	N/A	N/A	N/A
WB	Max - 1		Ant.E	AMR-WB 12.65 kbps	650000 3750 MHz	100 MHz	DFT-s-OFDM QPSK	1/1	26.9	12.99	N/A	N/A	N/A
WB	Max - 1		Ant.E	AMR-WB 23.85 kbps	650000 3750 MHz	100 MHz	DFT-s-OFDM QPSK	1/1	26.9	13.07	N/A	N/A	N/A
NB	Max - 1		Ant.E	EVS-NB 5.9 kbps	650000 3750 MHz	100 MHz	DFT-s-OFDM QPSK	1/1	26.9	15.15	N/A	N/A	N/A
NB	Max - 1		Ant.E	EVS-NB 13.2 kbps	650000 3750 MHz	100 MHz	DFT-s-OFDM QPSK	1/1	26.9	15.44	N/A	N/A	N/A
WB	Max - 1		Ant.E	EVS-WB 5.9 kbps	650000 3750 MHz	100 MHz	DFT-s-OFDM QPSK	1/1	26.9	12.82	N/A	N/A	N/A
WB	Max - 1		Ant.E	EVS-WB 16.4 kbps	650000 3750 MHz	100 MHz	DFT-s-OFDM QPSK	1/1	26.9	12.71	N/A	N/A	N/A
NB	Max - 1	WiFi 2.4GHz 802.11b	Ant.D	AMR-NB 4.75 kbps	CH6 2437 MHz	20 MHz	DSSS 1 Mbps	N/A	22.6	16.10	N/A	N/A	N/A
NB	Max - 1		Ant.D	AMR-NB 7.4 kbps	CH6 2437 MHz	20 MHz	DSSS 1 Mbps	N/A	22.6	16.65	N/A	N/A	N/A
NB	Max - 1		Ant.D	AMR-NB 12.2 kbps	CH6 2437 MHz	20 MHz	DSSS 1 Mbps	N/A	22.6	16.96	N/A	N/A	N/A
WB	Max - 1		Ant.D	AMR-WB 6.6 kbps	CH6 2437 MHz	20 MHz	DSSS 1 Mbps	N/A	22.6	13.25	N/A	N/A	N/A
WB	Max - 1		Ant.D	AMR-WB 12.65 kbps	CH6 2437 MHz	20 MHz	DSSS 1 Mbps	N/A	22.6	13.39	N/A	N/A	N/A
WB	Max - 1		Ant.D	AMR-WB 23.85 kbps	CH6 2437 MHz	20 MHz	DSSS 1 Mbps	N/A	22.6	13.49	N/A	N/A	N/A
NB	Max - 1		Ant.D	EVS-NB 5.9 kbps	CH6 2437 MHz	20 MHz	DSSS 1 Mbps	N/A	22.6	16.20	N/A	N/A	N/A
NB	Max - 1		Ant.D	EVS-NB 13.2 kbps	CH6 2437 MHz	20 MHz	DSSS 1 Mbps	N/A	22.6	16.39	N/A	N/A	N/A
WB	Max - 1		Ant.D	EVS-WB 5.9 kbps	CH6 2437 MHz	20 MHz	DSSS 1 Mbps	N/A	22.6	13.24	N/A	N/A	N/A
WB	Max - 1		Ant.D	EVS-WB 16.4 kbps	CH6 2437 MHz	20 MHz	DSSS 1 Mbps	N/A	22.6	13.34	N/A	N/A	N/A
NB	Max - 1	WiFi 5GHz 802.11a U-NII-1	Ant.D	AMR-NB 4.75 kbps	CH40 5200 MHz	20 MHz	BPSK 6 Mbps	N/A	22.6	16.09	N/A	N/A	N/A
NB	Max - 1		Ant.D	AMR-NB 7.4 kbps	CH40 5200 MHz	20 MHz	BPSK 6 Mbps	N/A	22.6	16.69	N/A	N/A	N/A
NB	Max - 1		Ant.D	AMR-NB 12.2 kbps	CH40 5200 MHz	20 MHz	BPSK 6 Mbps	N/A	22.6	16.95	N/A	N/A	N/A
WB	Max - 1		Ant.D	AMR-WB 6.6 kbps	CH40 5200 MHz	20 MHz	BPSK 6 Mbps	N/A	22.6	13.30	N/A	N/A	N/A
WB	Max - 1		Ant.D	AMR-WB 12.65 kbps	CH40 5200 MHz	20 MHz	BPSK 6 Mbps	N/A	22.6	13.44	N/A	N/A	N/A
WB	Max - 1		Ant.D	AMR-WB 23.85 kbps	CH40 5200 MHz	20 MHz	BPSK 6 Mbps	N/A	22.6	13.49	N/A	N/A	N/A
NB	Max - 1		Ant.D	EVS-NB 5.9 kbps	CH40 5200 MHz	20 MHz	BPSK 6 Mbps	N/A	22.6	16.16	N/A	N/A	N/A
NB	Max - 1		Ant.D	EVS-NB 13.2 kbps	CH40 5200 MHz	20 MHz	BPSK 6 Mbps	N/A	22.6	16.38	N/A	N/A	N/A
WB	Max - 1		Ant.D	EVS-WB 5.9 kbps	CH40 5200 MHz	20 MHz	BPSK 6 Mbps	N/A	22.6	13.31	N/A	N/A	N/A
WB	Max - 1		Ant.D	EVS-WB 16.4 kbps	CH40 5200 MHz	20 MHz	BPSK 6 Mbps	N/A	22.6	13.47	N/A	N/A	N/A

8N Mounting Force

Codec (NB or WB)	Volume Control Level	Mode / Band	Antenna	Voice Codec / Codec bitrate (kbps)	Channel and Frequency	Bandwidth	Waveform/ Modulation	RB (Allocation/ Offset)	Volume Control Results				
									8N				
									Noise (LAF_MAX) (dBA)	Conversational Gain (dB)	Frequency Response Margin (dB)		PN-SDNR margin (dB)
											FF	DF	
NB	Max - 1	GSM 850	Ant.A	FR V1	190 836.6 MHz	N/A	N/A	N/A	22.6	19.63	N/A	N/A	N/A
NB	Max - 1		Ant.A	FR V2	190 836.6 MHz	N/A	N/A	N/A	22.6	20.18	N/A	N/A	N/A
NB	Max - 1		Ant.A	HR V1	190 836.6 MHz	N/A	N/A	N/A	22.6	20.31	N/A	N/A	N/A
NB	Max - 1	GSM 1900	Ant.A	FR V1	661 1880 MHz	N/A	N/A	N/A	22.6	19.75	N/A	N/A	N/A
NB	Max - 1	WCDMA Band V	Ant.A	AMR-NB 4.75 kbps	4183 836.6 MHz	N/A	N/A	N/A	22.6	19.39	N/A	N/A	N/A
NB	Max - 1		Ant.A	AMR-NB 7.4 kbps	4183 836.6 MHz	N/A	N/A	N/A	22.6	19.90	N/A	N/A	N/A
NB	Max - 1		Ant.A	AMR-NB 12.2 kbps	4183 836.6 MHz	N/A	N/A	N/A	22.6	20.24	N/A	N/A	N/A
WB	Max - 1		Ant.A	AMR-WB 6.6 kbps	4183 836.6 MHz	N/A	N/A	N/A	22.6	16.64	N/A	N/A	N/A
WB	Max - 1		Ant.A	AMR-WB 12.65 kbps	4183 836.6 MHz	N/A	N/A	N/A	22.6	16.67	N/A	N/A	N/A
WB	Max - 1		Ant.A	AMR-WB 23.85 kbps	4183 836.6 MHz	N/A	N/A	N/A	22.6	16.76	N/A	N/A	N/A
WB	Max - 1		WCDMA Band II	Ant.A	AMR-WB 6.6 kbps	9400 1880.0 MHz	N/A	N/A	N/A	22.6	16.58	N/A	N/A
WB	Max - 1	WCDMA Band IV	Ant.A	AMR-WB 6.6 kbps	1413 1732.6 MHz	N/A	N/A	N/A	22.6	16.60	N/A	N/A	N/A
NB	Max - 1	LTE Band 66	Ant.A	AMR-NB 4.75 kbps	132322 1745 MHz	20 MHz	QPSK	1/0	22.6	19.26	N/A	N/A	N/A
NB	Max - 1		Ant.A	AMR-NB 7.4 kbps	132322 1745 MHz	20 MHz	QPSK	1/0	22.6	19.83	N/A	N/A	N/A
NB	Max - 1		Ant.A	AMR-NB 12.2 kbps	132322 1745 MHz	20 MHz	QPSK	1/0	22.6	20.09	N/A	N/A	N/A
WB	Max - 1		Ant.A	AMR-WB 6.6 kbps	132322 1745 MHz	20 MHz	QPSK	1/0	22.6	16.55	N/A	N/A	N/A
WB	Max - 1		Ant.A	AMR-WB 12.65 kbps	132322 1745 MHz	20 MHz	QPSK	1/0	22.6	16.70	N/A	N/A	N/A
WB	Max - 1		Ant.A	AMR-WB 23.85 kbps	132322 1745 MHz	20 MHz	QPSK	1/0	22.6	16.78	N/A	N/A	N/A
NB	Max - 1		Ant.A	EVS-NB 5.9 kbps	132322 1745 MHz	20 MHz	QPSK	1/0	22.6	19.37	N/A	N/A	N/A
NB	Max - 1		Ant.A	EVS-NB 13.2 kbps	132322 1745 MHz	20 MHz	QPSK	1/0	22.6	19.49	N/A	N/A	N/A
WB	Max - 1		Ant.A	EVS-WB 5.9 kbps	132322 1745 MHz	20 MHz	QPSK	1/0	22.6	16.51	N/A	N/A	N/A
WB	Max - 1		Ant.A	EVS-WB 16.4 kbps	132322 1745 MHz	20 MHz	QPSK	1/0	22.6	16.70	N/A	N/A	N/A
NB	Max - 1	LTE Band 41 PC2	Ant.A	AMR-NB 4.75 kbps	40620 2593 MHz	20 MHz	QPSK	1/0	22.6	19.29	N/A	N/A	N/A
NB	Max - 1		Ant.A	AMR-NB 7.4 kbps	40620 2593 MHz	20 MHz	QPSK	1/0	22.6	19.83	N/A	N/A	N/A
NB	Max - 1		Ant.A	AMR-NB 12.2 kbps	40620 2593 MHz	20 MHz	QPSK	1/0	22.6	20.09	N/A	N/A	N/A
WB	Max - 1		Ant.A	AMR-WB 6.6 kbps	40620 2593 MHz	20 MHz	QPSK	1/0	22.6	16.58	N/A	N/A	N/A
WB	Max - 1		Ant.A	AMR-WB 12.65 kbps	40620 2593 MHz	20 MHz	QPSK	1/0	22.6	16.69	N/A	N/A	N/A
WB	Max - 1		Ant.A	AMR-WB 23.85 kbps	40620 2593 MHz	20 MHz	QPSK	1/0	22.6	16.75	N/A	N/A	N/A
NB	Max - 1		Ant.A	EVS-NB 5.9 kbps	40620 2593 MHz	20 MHz	QPSK	1/0	22.6	19.37	N/A	N/A	N/A
NB	Max - 1		Ant.A	EVS-NB 13.2 kbps	40620 2593 MHz	20 MHz	QPSK	1/0	22.6	19.53	N/A	N/A	N/A
WB	Max - 1		Ant.A	EVS-WB 5.9 kbps	40620 2593 MHz	20 MHz	QPSK	1/0	22.6	16.52	N/A	N/A	N/A
WB	Max - 1		Ant.A	EVS-WB 16.4 kbps	40620 2593 MHz	20 MHz	QPSK	1/0	22.6	16.72	N/A	N/A	N/A

8N Mounting Force (Continued)

Codec (NB or WB)	Volume Control Level	Mode / Band	Antenna	Voice Codec / Codec bitrate (kbps)	Channel and Frequency	Bandwidth	Waveform/ Modulation	RB (Allocation/ Offset)	Volume Control Results				
									8N				
									Noise (LAF_MAX) (dBA)	Conversational Gain (dB)	Frequency Response Margin (dB)		PN-SDNR margin (dB)
											FF	DF	
NB	Max - 1	NR Band n66	Ant.A	AMR-NB 4.75 kbps	349000 1745.00 MHz	40 MHz	DFT-s-OFDM QPSK	1/1	27.1	18.68	N/A	N/A	N/A
NB	Max - 1		Ant.A	AMR-NB 7.4 kbps	349000 1745.00 MHz	40 MHz	DFT-s-OFDM QPSK	1/1	27.1	19.11	N/A	N/A	N/A
NB	Max - 1		Ant.A	AMR-NB 12.2 kbps	349000 1745.00 MHz	40 MHz	DFT-s-OFDM QPSK	1/1	27.1	19.37	N/A	N/A	N/A
WB	Max - 1		Ant.A	AMR-WB 6.6 kbps	349000 1745.00 MHz	40 MHz	DFT-s-OFDM QPSK	1/1	27.1	16.63	N/A	N/A	N/A
WB	Max - 1		Ant.A	AMR-WB 12.65 kbps	349000 1745.00 MHz	40 MHz	DFT-s-OFDM QPSK	1/1	27.1	16.87	N/A	N/A	N/A
WB	Max - 1		Ant.A	AMR-WB 23.85 kbps	349000 1745.00 MHz	40 MHz	DFT-s-OFDM QPSK	1/1	27.1	16.93	N/A	N/A	N/A
NB	Max - 1		Ant.A	EVS-NB 5.9 kbps	349000 1745.00 MHz	40 MHz	DFT-s-OFDM QPSK	1/1	27.1	18.78	N/A	N/A	N/A
NB	Max - 1		Ant.A	EVS-NB 13.2 kbps	349000 1745.00 MHz	40 MHz	DFT-s-OFDM QPSK	1/1	27.1	19.10	N/A	N/A	N/A
WB	Max - 1		Ant.A	EVS-WB 5.9 kbps	349000 1745.00 MHz	40 MHz	DFT-s-OFDM QPSK	1/1	27.1	16.60	N/A	N/A	N/A
WB	Max - 1		Ant.A	EVS-WB 16.4 kbps	349000 1745.00 MHz	40 MHz	DFT-s-OFDM QPSK	1/1	27.1	16.83	N/A	N/A	N/A
NB	Max - 1	NR Band n77 HPUE	Ant.E	AMR-NB 4.75 kbps	650000 3750 MHz	100 MHz	DFT-s-OFDM QPSK	1/1	26.9	18.94	N/A	N/A	N/A
NB	Max - 1		Ant.E	AMR-NB 7.4 kbps	650000 3750 MHz	100 MHz	DFT-s-OFDM QPSK	1/1	26.9	19.41	N/A	N/A	N/A
NB	Max - 1		Ant.E	AMR-NB 12.2 kbps	650000 3750 MHz	100 MHz	DFT-s-OFDM QPSK	1/1	26.9	19.74	N/A	N/A	N/A
WB	Max - 1		Ant.E	AMR-WB 6.6 kbps	650000 3750 MHz	100 MHz	DFT-s-OFDM QPSK	1/1	26.9	16.85	N/A	N/A	N/A
WB	Max - 1		Ant.E	AMR-WB 12.65 kbps	650000 3750 MHz	100 MHz	DFT-s-OFDM QPSK	1/1	26.9	17.03	N/A	N/A	N/A
WB	Max - 1		Ant.E	AMR-WB 23.85 kbps	650000 3750 MHz	100 MHz	DFT-s-OFDM QPSK	1/1	26.9	17.06	N/A	N/A	N/A
NB	Max - 1		Ant.E	EVS-NB 5.9 kbps	650000 3750 MHz	100 MHz	DFT-s-OFDM QPSK	1/1	26.9	19.10	N/A	N/A	N/A
NB	Max - 1		Ant.E	EVS-NB 13.2 kbps	650000 3750 MHz	100 MHz	DFT-s-OFDM QPSK	1/1	26.9	19.37	N/A	N/A	N/A
WB	Max - 1		Ant.E	EVS-WB 5.9 kbps	650000 3750 MHz	100 MHz	DFT-s-OFDM QPSK	1/1	26.9	16.80	N/A	N/A	N/A
WB	Max - 1		Ant.E	EVS-WB 16.4 kbps	650000 3750 MHz	100 MHz	DFT-s-OFDM QPSK	1/1	26.9	17.06	N/A	N/A	N/A
NB	Max - 1	WiFi 2.4GHz 802.11b	Ant.D	AMR-NB 4.75 kbps	CH6 2437 MHz	20 MHz	DSSS 1 Mbps	N/A	22.6	19.36	N/A	N/A	N/A
NB	Max - 1		Ant.D	AMR-NB 7.4 kbps	CH6 2437 MHz	20 MHz	DSSS 1 Mbps	N/A	22.6	19.88	N/A	N/A	N/A
NB	Max - 1		Ant.D	AMR-NB 12.2 kbps	CH6 2437 MHz	20 MHz	DSSS 1 Mbps	N/A	22.6	20.10	N/A	N/A	N/A
WB	Max - 1		Ant.D	AMR-WB 6.6 kbps	CH6 2437 MHz	20 MHz	DSSS 1 Mbps	N/A	22.6	16.60	N/A	N/A	N/A
WB	Max - 1		Ant.D	AMR-WB 12.65 kbps	CH6 2437 MHz	20 MHz	DSSS 1 Mbps	N/A	22.6	16.63	N/A	N/A	N/A
WB	Max - 1		Ant.D	AMR-WB 23.85 kbps	CH6 2437 MHz	20 MHz	DSSS 1 Mbps	N/A	22.6	16.68	N/A	N/A	N/A
NB	Max - 1		Ant.D	EVS-NB 5.9 kbps	CH6 2437 MHz	20 MHz	DSSS 1 Mbps	N/A	22.6	19.44	N/A	N/A	N/A
NB	Max - 1		Ant.D	EVS-NB 13.2 kbps	CH6 2437 MHz	20 MHz	DSSS 1 Mbps	N/A	22.6	19.58	N/A	N/A	N/A
WB	Max - 1		Ant.D	EVS-WB 5.9 kbps	CH6 2437 MHz	20 MHz	DSSS 1 Mbps	N/A	22.6	16.48	N/A	N/A	N/A
WB	Max - 1		Ant.D	EVS-WB 16.4 kbps	CH6 2437 MHz	20 MHz	DSSS 1 Mbps	N/A	22.6	16.65	N/A	N/A	N/A
NB	Max - 1	WiFi 5GHz 802.11a U-NII-1	Ant.D	AMR-NB 4.75 kbps	CH40 5200 MHz	20 MHz	BPSK 6 Mbps	N/A	22.6	19.23	N/A	N/A	N/A
NB	Max - 1		Ant.D	AMR-NB 7.4 kbps	CH40 5200 MHz	20 MHz	BPSK 6 Mbps	N/A	22.6	19.91	N/A	N/A	N/A
NB	Max - 1		Ant.D	AMR-NB 12.2 kbps	CH40 5200 MHz	20 MHz	BPSK 6 Mbps	N/A	22.6	20.11	N/A	N/A	N/A
WB	Max - 1		Ant.D	AMR-WB 6.6 kbps	CH40 5200 MHz	20 MHz	BPSK 6 Mbps	N/A	22.6	16.51	N/A	N/A	N/A
WB	Max - 1		Ant.D	AMR-WB 12.65 kbps	CH40 5200 MHz	20 MHz	BPSK 6 Mbps	N/A	22.6	16.59	N/A	N/A	N/A
WB	Max - 1		Ant.D	AMR-WB 23.85 kbps	CH40 5200 MHz	20 MHz	BPSK 6 Mbps	N/A	22.6	16.66	N/A	N/A	N/A
NB	Max - 1		Ant.D	EVS-NB 5.9 kbps	CH40 5200 MHz	20 MHz	BPSK 6 Mbps	N/A	22.6	19.28	N/A	N/A	N/A
NB	Max - 1		Ant.D	EVS-NB 13.2 kbps	CH40 5200 MHz	20 MHz	BPSK 6 Mbps	N/A	22.6	19.52	N/A	N/A	N/A
WB	Max - 1		Ant.D	EVS-WB 5.9 kbps	CH40 5200 MHz	20 MHz	BPSK 6 Mbps	N/A	22.6	16.42	N/A	N/A	N/A
WB	Max - 1		Ant.D	EVS-WB 16.4 kbps	CH40 5200 MHz	20 MHz	BPSK 6 Mbps	N/A	22.6	16.64	N/A	N/A	N/A

9.4. HAC (Volume Control) Test Results

2N Mounting Force – Summary

Codec (NB or WB)	Volume Control Level	Mode / Band	Antenna	Voice Codec / Codec bitrate (kbps)	Channel and Frequency	Bandwidth	Waveform / Modulation	RB (Allocation / Offset)	Volume Control Results					Plot No.
									Noise (LAF_MAX) (dBA)	Conversational Gain (dB)	2N		PN-SDNR margin (dB)	
											FF	DF		
NB	Max - 1	GSM 850	Ant.A	FR V1	190 836.8 MHz	N/A	N/A	N/A	22.6	16.57	N/A	N/A	N/A	
NB	Max - 1	GSM 1900	Ant.A	FR V1	661 1880 MHz	N/A	N/A	N/A	22.6	16.41	N/A	N/A	N/A	
NB	Max - 1	WCDMA Band V	Ant.A	AMR-WB 6.6 kbps	4183 836.5 MHz	N/A	N/A	N/A	22.6	13.29	N/A	N/A	N/A	
NB	Max - 1	WCDMA Band II	Ant.A	AMR-WB 6.6 kbps	9400 1880.0 MHz	N/A	N/A	N/A	22.6	13.24	N/A	N/A	N/A	
NB	Max - 1	WCDMA Band IV	Ant.A	AMR-WB 6.6 kbps	1413 1732.6 MHz	N/A	N/A	N/A	22.6	13.28	N/A	N/A	N/A	
WB	Max - 1	LTE Band 2	Ant.A	EVS-WB 24.4 kbit/s	18900 1880 MHz	20 MHz	QPSK	1/0	26.7	12.52	3.23	2.40	5.86	1
WB	Max - 1	LTE Band 4	Ant.A	EVS-WB 24.4 kbit/s	20175 1732.5 MHz	20 MHz	QPSK	1/0	26.7	12.53	3.34	2.20	7.87	2
WB	Max - 1	LTE Band 5	Ant.A	EVS-WB 24.4 kbit/s	20525 836.5 MHz	10 MHz	QPSK	1/0	26.7	12.51	3.37	2.60	6.92	3
WB	Max - 1	LTE Band 7	Ant.A	EVS-WB 24.4 kbit/s	21100 2535 MHz	20 MHz	QPSK	1/0	26.7	12.57	3.21	2.20	5.97	4
WB	Max - 1	LTE Band 12	Ant.A	EVS-WB 24.4 kbit/s	23095 707.5 MHz	10 MHz	QPSK	1/0	26.7	12.60	2.29	1.60	7.08	5
WB	Max - 1	LTE Band 13	Ant.A	EVS-WB 24.4 kbit/s	23230 782 MHz	10 MHz	QPSK	1/0	26.7	12.55	3.27	2.20	4.14	6
WB	Max - 1	LTE Band 14	Ant.A	EVS-WB 24.4 kbit/s	23330 793 MHz	10 MHz	QPSK	1/0	26.7	12.56	3.27	2.20	6.38	7
WB	Max - 1	LTE Band 25	Ant.A	EVS-WB 24.4 kbit/s	26365 1882.5 MHz	20 MHz	QPSK	1/0	26.7	12.55	3.32	2.20	5.86	8
WB	Max - 1	LTE Band 26	Ant.A	EVS-WB 24.4 kbit/s	26865 831.5 MHz	15 MHz	QPSK	1/0	26.7	12.54	3.20	2.10	6.74	9
WB	Max - 1	LTE Band 30	Ant.A	EVS-WB 24.4 kbit/s	27710 2310 MHz	10 MHz	QPSK	1/0	26.7	12.49	3.26	2.30	6.39	10
WB	Max - 1	LTE Band 66	Ant.A	EVS-WB 5.9 kbps	132322 1745 MHz	20 MHz	QPSK	1/0	22.6	13.21	N/A	N/A	N/A	
WB	Max - 1	LTE Band 66	Ant.A	EVS-WB 24.4 kbit/s	132322 1745 MHz	20 MHz	QPSK	1/0	26.1	12.46	3.25	2.30	5.98	11
WB	Max - 1	LTE Band 71	Ant.A	EVS-WB 24.4 kbit/s	132977 680.5 MHz	20 MHz	QPSK	1/0	26.7	12.52	3.13	2.00	7.23	12
WB	Max - 1	LTE Band 38	Ant.A	EVS-WB 24.4 kbit/s	38000 2595 MHz	20 MHz	QPSK	1/0	26.4	12.55	3.24	2.20	5.70	13
WB	Max - 1	LTE Band 41 PC2	Ant.A	AMR-WB 6.6 kbps	40620 2593 MHz	20 MHz	QPSK	1/0	22.6	13.24	N/A	N/A	N/A	
WB	Max - 1	LTE Band 41 PC2	Ant.A	EVS-WB 24.4 kbit/s	40620 2593 MHz	20 MHz	QPSK	1/0	26.4	12.17	3.17	2.10	5.47	14
WB	Max - 1	LTE Band 41 PC3	Ant.A	EVS-WB 24.4 kbit/s	40620 2593 MHz	20 MHz	QPSK	1/0	26.7	12.30	3.29	2.20	5.28	15
WB	Max - 1	LTE Band 48	Ant.A	EVS-WB 24.4 kbit/s	55773 3603.3 MHz	20 MHz	QPSK	1/0	26.4	12.54	3.16	2.10	5.69	16
WB	Max - 1	NR Band n2	Ant.A	EVS-WB 24.4 kbit/s	376000 1880.00 MHz	40 MHz	DFT-s-OFDM QPSK	1/1	27.1	12.74	3.61	3.00	7.34	17
WB	Max - 1	NR Band n5	Ant.A	EVS-WB 24.4 kbit/s	167300 836.50 MHz	20 MHz	DFT-s-OFDM QPSK	1/1	27.1	12.77	3.50	2.80	7.67	18
WB	Max - 1	NR Band n25	Ant.A	EVS-WB 24.4 kbit/s	376500 1882.5 MHz	40 MHz	DFT-s-OFDM QPSK	1/1	27.1	12.71	3.59	3.20	7.97	19
WB	Max - 1	NR Band n30	Ant.A	EVS-WB 24.4 kbit/s	462000 2310 MHz	10 MHz	DFT-s-OFDM QPSK	1/1	27.1	12.77	3.48	3.00	7.99	20
WB	Max - 1	NR Band n66	Ant.A	EVS-WB 5.9 kbps	349000 1745 MHz	40 MHz	DFT-s-OFDM QPSK	1/1	27.1	12.53	N/A	N/A	N/A	
WB	Max - 1	NR Band n66	Ant.A	EVS-WB 24.4 kbit/s	349000 1745 MHz	40 MHz	DFT-s-OFDM QPSK	1/1	27.1	12.64	3.42	3.10	8.31	21
WB	Max - 1	NR Band n70	Ant.A	EVS-WB 24.4 kbit/s	340500 1702.5 MHz	15 MHz	DFT-s-OFDM QPSK	1/1	27.1	12.74	3.48	3.10	6.62	22
WB	Max - 1	NR Band n71	Ant.A	EVS-WB 24.4 kbit/s	136100 680.5 MHz	20 MHz	DFT-s-OFDM QPSK	1/1	27.1	12.73	3.62	2.90	6.83	23
WB	Max - 1	NR Band n41 HPUE	Ant.A	EVS-WB 24.4 kbit/s	518598 2592.99 MHz	100 MHz	DFT-s-OFDM QPSK	1/1	26.9	13.02	3.49	2.50	7.15	24
WB	Max - 1	NR Band n48	Ant.E	EVS-WB 24.4 kbit/s	641666 3624.99 MHz	40 MHz	DFT-s-OFDM QPSK	1/1	26.9	13.03	3.47	2.40	5.55	25
WB	Max - 1	NR Band n77 HPUE	Ant.E	EVS-WB 16.4 kbps	650000 3750 MHz	100 MHz	DFT-s-OFDM QPSK	1/1	26.9	12.71	N/A	N/A	N/A	
WB	Max - 1	NR Band n77 HPUE	Ant.E	EVS-WB 24.4 kbit/s	650000 3750 MHz	100 MHz	DFT-s-OFDM QPSK	1/1	26.9	12.94	3.55	2.60	6.61	26
WB	Max - 1	NR Band n78	Ant.E	EVS-WB 24.4 kbit/s	650000 3750 MHz	100 MHz	DFT-s-OFDM QPSK	1/1	26.9	13.02	3.48	2.60	7.65	27
WB	Max - 1	WiFi 2.4GHz 802.11b	Ant.D	EVS-WB 5.9 kbps	CH.6 2437 MHz	20 MHz	DSSS 1 Mbps	N/A	22.6	13.24	N/A	N/A	N/A	
WB	Max - 1	WiFi 2.4GHz 802.11b	Ant.D	EVS-WB 24.4 kbit/s	CH.6 2437 MHz	20 MHz	DSSS 1 Mbps	N/A	26.5	12.50	2.19	1.80	8.37	28
WB	Max - 1	WiFi 5GHz 802.11a U-NII-1	Ant.D	AMR-WB 6.6 kbps	CH.40 5200 MHz	20 MHz	BPSK 6 Mbps	N/A	22.6	13.30	N/A	N/A	N/A	
WB	Max - 1	WiFi 5GHz 802.11n HT20 U-NII-1	Ant.D	EVS-WB 24.4 kbit/s	CH.40 5200 MHz	20 MHz	MCS 0 6.5 Mbps	N/A	26.2	12.18	2.32	1.70	7.52	29
WB	Max - 1	WiFi 5GHz 802.11n HT20 U-NII-2A	Ant.D	EVS-WB 24.4 kbit/s	CH.56 5280 MHz	20 MHz	MCS 0 6.5 Mbps	N/A	26.2	12.20	1.93	1.70	5.73	30
WB	Max - 1	WiFi 5GHz 802.11n HT20 U-NII-2C	Ant.D	EVS-WB 24.4 kbit/s	CH.120 5600 MHz	20 MHz	MCS 0 6.5 Mbps	N/A	26.2	12.76	2.12	1.60	8.33	31
WB	Max - 1	WiFi 5GHz 802.11n HT20 U-NII-3	Ant.D	EVS-WB 24.4 kbit/s	CH.157 5785 MHz	20 MHz	MCS 0 6.5 Mbps	N/A	26.2	12.67	2.84	1.80	6.65	32

Note:

- Under the waiver, at least one of the device's narrowband and one of the device's wideband codecs need to be chosen for the distortion and frequency response testing. Testing of the chosen narrowband and wideband codecs for the distortion/noise and frequency response is limited to one bit rate and only those air interfaces associated with the chosen codecs-EVS NB 24.4 kbps & EVS WB 24.4 kbps. The other narrowband and wideband codecs used for the 2N and 8N force level conversational gain tests are not required to undergo distortion/noise and frequency response testing. This codec is therefore not subjected to the distortion and frequency response testing.
- Worst conversational gain for 2N mounting force is 12.17 dB.

8N Mounting Force – Summary

Codec (NB or WB)	Volume Control Level	Mode / Band	Antenna	Voice Codec / Codec bitrate (kbps)	Channel and Frequency	Bandwidth	Waveform / Modulation	RB (Allocation/ Offset)	Volume Control Results					Plot No.
									8N					
									Noise (LAF_MAX) (dBA)	Conversational Gain (dB)	Frequency Response Margin (dB)		PN-SDNR margin (dB)	
		FF	DF											
NB	Max - 1	GSM 850	Ant.A	FR V1	190 836.6 MHz	N/A	N/A	N/A	22.6	19.63	N/A	N/A	N/A	
NB	Max - 1	GSM 1900	Ant.A	FR V1	661 1880 MHz	N/A	N/A	N/A	22.6	19.75	N/A	N/A	N/A	
NB	Max - 1	WCDMA Band V	Ant.A	AMR-WB 6.6 kbps	4183 836.6 MHz	N/A	N/A	N/A	22.6	16.64	N/A	N/A	N/A	
NB	Max - 1	WCDMA Band II	Ant.A	AMR-WB 6.6 kbps	9400 1880.0 MHz	N/A	N/A	N/A	22.6	16.58	N/A	N/A	N/A	
NB	Max - 1	WCDMA Band IV	Ant.A	AMR-WB 6.6 kbps	1413 1732.6 MHz	N/A	N/A	N/A	22.6	16.60	N/A	N/A	N/A	
WB	Max - 1	LTE Band 2	Ant.A	EVS-WB 24.4 kbit/s	18900 1880 MHz	20 MHz	QPSK	1/0	26.1	16.87	3.36	3.10	6.70	33
WB	Max - 1	LTE Band 4	Ant.A	EVS-WB 24.4 kbit/s	20175 1732.5 MHz	20 MHz	QPSK	1/0	26.1	16.85	3.39	3.10	7.10	34
WB	Max - 1	LTE Band 5	Ant.A	EVS-WB 24.4 kbit/s	20625 836.5 MHz	10 MHz	QPSK	1/0	26.1	16.83	3.42	2.90	5.70	35
WB	Max - 1	LTE Band 7	Ant.A	EVS-WB 24.4 kbit/s	21100 2535 MHz	20 MHz	QPSK	1/0	26.1	16.98	2.98	2.20	6.50	36
WB	Max - 1	LTE Band 12	Ant.A	EVS-WB 24.4 kbit/s	23095 707.5 MHz	10 MHz	QPSK	1/0	26.1	16.96	3.22	2.60	6.00	37
WB	Max - 1	LTE Band 13	Ant.A	EVS-WB 24.4 kbit/s	23230 782 MHz	10 MHz	QPSK	1/0	26.1	16.93	3.33	2.70	7.30	38
WB	Max - 1	LTE Band 14	Ant.A	EVS-WB 24.4 kbit/s	23330 793 MHz	10 MHz	QPSK	1/0	26.1	16.92	3.34	2.90	7.00	39
WB	Max - 1	LTE Band 25	Ant.A	EVS-WB 24.4 kbit/s	26365 1882.5 MHz	20 MHz	QPSK	1/0	26.1	16.90	3.34	2.80	7.20	40
WB	Max - 1	LTE Band 26	Ant.A	EVS-WB 24.4 kbit/s	26865 831.5 MHz	15 MHz	QPSK	1/0	26.1	16.87	3.34	2.90	6.60	41
WB	Max - 1	LTE Band 30	Ant.A	EVS-WB 24.4 kbit/s	27710 2310 MHz	10 MHz	QPSK	1/0	26.1	16.91	3.43	3.10	5.40	42
WB	Max - 1	LTE Band 66	Ant.A	EVS-WB 5.9 kbps	132322 1745 MHz	20 MHz	QPSK	1/0	22.6	16.51	N/A	N/A	N/A	
WB	Max - 1	LTE Band 66	Ant.A	EVS-WB 24.4 kbit/s	132322 1745 MHz	20 MHz	QPSK	1/0	26.1	16.78	3.36	3.10	8.20	43
WB	Max - 1	LTE Band 71	Ant.A	EVS-WB 24.4 kbit/s	133297 680.5 MHz	20 MHz	QPSK	1/0	26.1	16.88	3.37	3.00	5.90	44
WB	Max - 1	LTE Band 38	Ant.A	EVS-WB 24.4 kbit/s	38000 2595 MHz	20 MHz	QPSK	1/0	26.4	16.82	3.36	3.10	7.90	45
WB	Max - 1	LTE Band 41 PC2	Ant.A	EVS-WB 5.9 kbps	40620 2593 MHz	20 MHz	QPSK	1/0	22.6	16.52	N/A	N/A	N/A	
WB	Max - 1	LTE Band 41 PC2	Ant.A	EVS-WB 24.4 kbit/s	40620 2593 MHz	20 MHz	QPSK	1/0	26.4	16.69	3.39	3.10	5.20	46
WB	Max - 1	LTE Band 41 PC3	Ant.A	EVS-WB 24.4 kbit/s	40620 2593 MHz	20 MHz	QPSK	1/0	26.4	16.83	3.37	3.10	4.40	47
WB	Max - 1	LTE Band 48	Ant.A	EVS-WB 24.4 kbit/s	55773 3603.3 MHz	20 MHz	QPSK	1/0	26.4	16.86	3.43	2.90	7.30	48
WB	Max - 1	NR Band n2	Ant.A	EVS-WB 24.4 kbit/s	376000 1880.00 MHz	40 MHz	DFT-s-OFDM QPSK	1/1	27.1	16.89	3.56	3.30	8.30	49
WB	Max - 1	NR Band n5	Ant.A	EVS-WB 24.4 kbit/s	167300 836.50 MHz	20 MHz	DFT-s-OFDM QPSK	1/1	27.1	16.95	3.53	3.20	7.90	50
WB	Max - 1	NR Band n25	Ant.A	EVS-WB 24.4 kbit/s	376500 1882.5 MHz	40 MHz	DFT-s-OFDM QPSK	1/1	27.1	16.92	3.54	3.30	7.00	51
WB	Max - 1	NR Band n30	Ant.A	EVS-WB 24.4 kbit/s	462000 2310 MHz	10 MHz	DFT-s-OFDM QPSK	1/1	27.1	16.92	3.60	3.30	8.20	52
WB	Max - 1	NR Band n66	Ant.A	EVS-WB 5.9 kbps	349000 1745 MHz	40 MHz	DFT-s-OFDM QPSK	1/1	27.1	16.60	N/A	N/A	N/A	
WB	Max - 1	NR Band n66	Ant.A	EVS-WB 24.4 kbit/s	349000 1745 MHz	40 MHz	DFT-s-OFDM QPSK	1/1	27.5	16.88	3.48	2.90	6.20	53
WB	Max - 1	NR Band n70	Ant.A	EVS-WB 24.4 kbit/s	340500 1702.5 MHz	15 MHz	DFT-s-OFDM QPSK	1/1	27.1	16.93	3.51	3.20	8.40	54
WB	Max - 1	NR Band n71	Ant.A	EVS-WB 24.4 kbit/s	136100 680.5 MHz	20 MHz	DFT-s-OFDM QPSK	1/1	27.1	16.91	3.52	3.30	8.50	55
WB	Max - 1	NR Band n41 HPUE	Ant.A	EVS-WB 24.4 kbit/s	518598 2592.99 MHz	100 MHz	DFT-s-OFDM QPSK	1/1	26.5	16.88	3.51	3.20	8.20	56
WB	Max - 1	NR Band n48	Ant.E	EVS-WB 24.4 kbit/s	641666 3624.99 MHz	40 MHz	DFT-s-OFDM QPSK	1/1	26.5	16.89	3.58	3.10	6.70	57
WB	Max - 1	NR Band n77 HPUE	Ant.E	EVS-WB 5.9 kbps	650000 3750 MHz	100 MHz	DFT-s-OFDM QPSK	1/1	26.9	16.80	N/A	N/A	N/A	
WB	Max - 1	NR Band n77 HPUE	Ant.E	EVS-WB 24.4 kbit/s	650000 3750 MHz	100 MHz	DFT-s-OFDM QPSK	1/1	26.5	16.85	3.47	3.10	8.10	58
WB	Max - 1	NR Band n78	Ant.E	EVS-WB 24.4 kbit/s	650000 3750 MHz	100 MHz	DFT-s-OFDM QPSK	1/1	26.5	16.94	3.52	3.20	8.30	59
WB	Max - 1	WiFi 2.4GHz 802.11b	Ant.D	EVS-WB 5.9 kbps	CH.6 2437 MHz	20 MHz	SSSS 1 Mbps	N/A	22.6	16.48	N/A	N/A	N/A	
WB	Max - 1	WiFi 2.4GHz 802.11b	Ant.D	EVS-WB 24.4 kbit/s	CH.6 2437 MHz	20 MHz	SSSS 1 Mbps	N/A	26.5	16.70	2.95	2.40	8.00	60
WB	Max - 1	WiFi 5GHz 802.11a U-NII-1	Ant.D	EVS-WB 5.9 kbps	CH.40 5200 MHz	20 MHz	BPSK 6 Mbps	N/A	22.6	16.42	N/A	N/A	N/A	
WB	Max - 1	WiFi 5GHz 802.11ac VHT20 U-NII-1	Ant.D	EVS-WB 24.4 kbit/s	CH.40 5200 MHz	20 MHz	MCS 0 6.5 Mbps	N/A	26.2	16.78	2.95	2.30	7.40	61
WB	Max - 1	WiFi 5GHz 802.11ac VHT20 U-NII-2A	Ant.D	EVS-WB 24.4 kbit/s	CH.56 5280 MHz	20 MHz	MCS 0 6.5 Mbps	N/A	26.2	16.80	2.86	2.30	7.20	62
WB	Max - 1	WiFi 5GHz 802.11ac VHT20 U-NII-2C	Ant.D	EVS-WB 24.4 kbit/s	CH.120 5600 MHz	20 MHz	MCS 0 6.5 Mbps	N/A	26.2	16.82	2.97	2.40	7.90	63
WB	Max - 1	WiFi 5GHz 802.11ac VHT20 U-NII-3	Ant.D	EVS-WB 24.4 kbit/s	CH.157 5785 MHz	20 MHz	MCS 0 6.5 Mbps	N/A	26.2	16.81	3.03	2.50	7.50	64

Note:

- Under the waiver, at least one of the device's narrowband and one of the device's wideband codecs need to be chosen for the distortion and frequency response testing. Testing of the chosen narrowband and wideband codecs for the distortion/noise and frequency response is limited to one bit rate and only those air interfaces associated with the chosen codecs-EVS NB 24.4 kbps & EVS WB 24.4 kbps. The other narrowband and wideband codecs used for the 2N and 8N force level conversational gain tests are not required to undergo distortion/noise and frequency response testing. This codec is therefore not subjected to the distortion and frequency response testing.
- Worst conversational gain for 8N mounting force is 16.42 dB.

9.5. Worst Case Volume Control Test Plot

2N Mounting Force – VoLTE Band 41 PC2_ Ant.A_EVS-WB 24.4 kbps_ch.40620

Conversational Gain 12.17 dB



TIA-5050 Receive Volume Control Measurements - 2N

Device Under Test:	20240924_L41_WB_2N
Bandwidth	Wideband
Test Date:	2024-09-24

Receive Volume Control Performance

TIA-5050	Test	Measured	Limits	Result	Reference
Clause 5.1	Recv output level dBSPL 2N	82.17 dB	info only		
	Recv conversational gain 2N	12.17 dB	6.00	PASS	

Receive Distortion and Noise Performance

TIA-5050	Test	Margin	Limits	Result	Reference
Clause 5.2	Recv PN-SDNR 2N	5.47 dB	Absolute Limits	PASS	

Note: SDNR includes noise and distortion products.

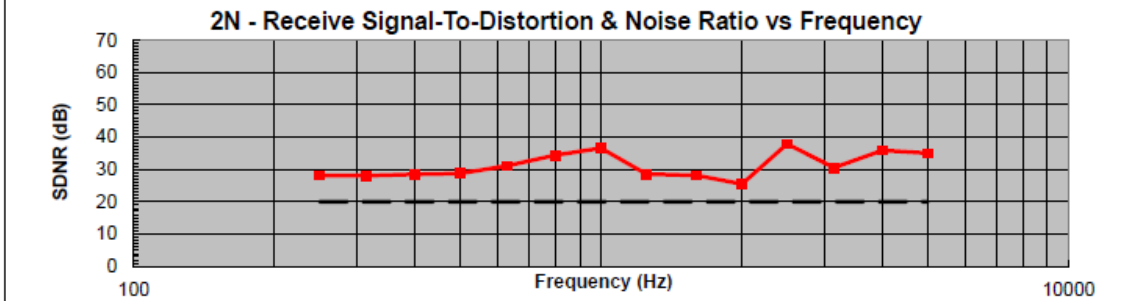

Receive Acoustic Frequency Response Performance

TIA-5050	Test	Margin	Limits	Result	Reference
Clause 5.3	Recv resp FF 2N	3.17 dB	Floating Limits	PASS	
	Recv resp DF 2N	2.1 dB	Floating Limits	PASS	

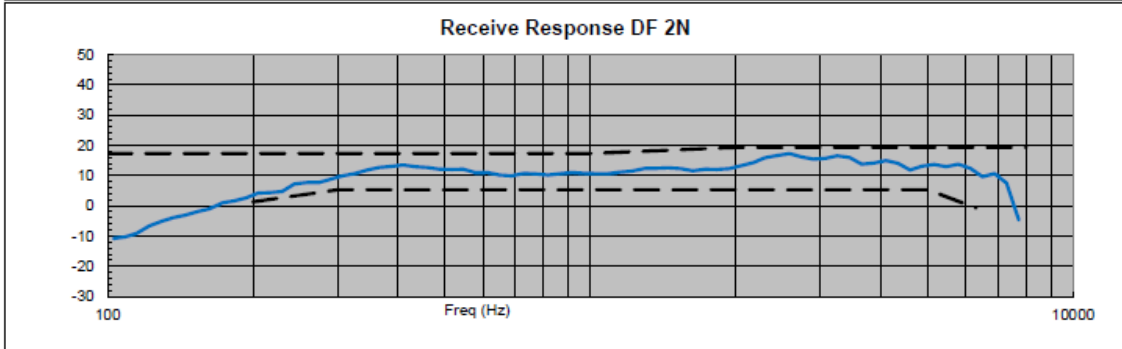
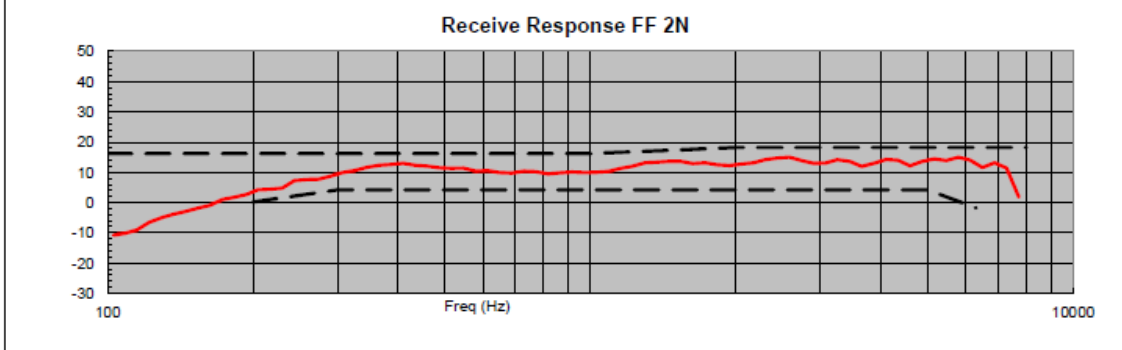

8N Mounting Force – VoWiFi 5GHz 802.11a_Ant.D_EVS-WB 5.9 kbps_ch.40

Conversational Gain 16.42 dB (tested conversational gain only)

8N Mounting Force – VoLTE Band 41 PC2_Ant.A_EVS-WB 24.4 kbps_ch.40620

Conversational Gain 16.69 dB



TIA-5050 Receive Volume Control Measurements - 8N

Device Under Test:	20240924_L41_WB
Bandwidth:	Wideband
Test Date:	2024-09-24

Receive Volume Control Performance

TIA-5050	Test	Measured	Limits	Result	Reference
Clause 5.1	Recv output level dB SPL 8N	86.69 dB	info only		
	Recv conversational gain 8N	16.69 dB	6.00	PASS	

Receive Distortion and Noise Performance

TIA-5050	Test	Margin	Limits	Result	Reference
Clause 5.2	Recv PN-SDNR 8N	5.2 dB	Absolute Limits	PASS	

Note: SDNR includes noise and distortion products.

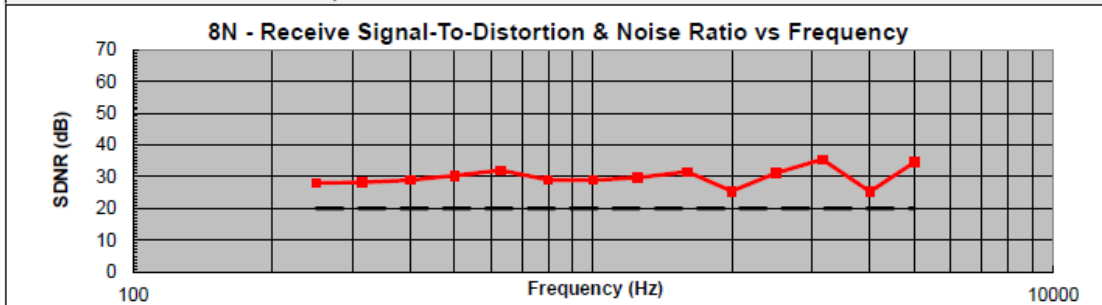

Receive Acoustic Frequency Response Performance

TIA-5050	Test	Margin	Limits	Result	Reference
Clause 5.3	Recv resp FF 8N	3.39 dB	Floating Limits	PASS	
	Recv resp DF 8N	3.1 dB	Floating Limits	PASS	

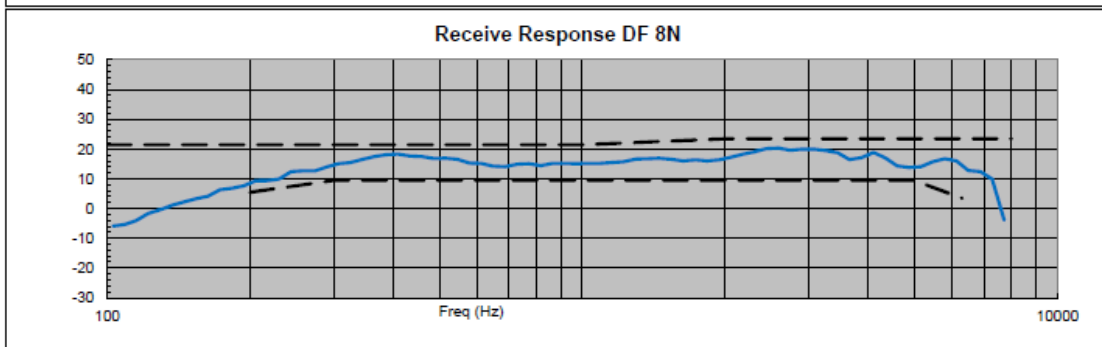
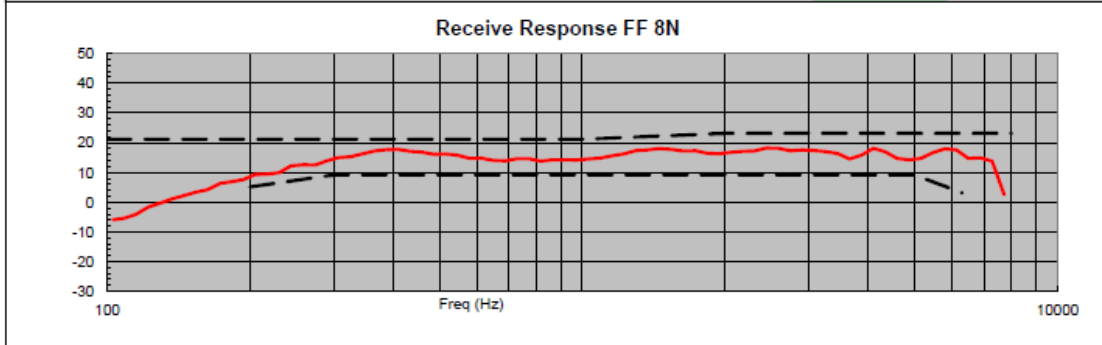

Appendix

Refer to separated files for the following appendixes

4791440365-S4 Appendix A_Setup Photo

4791440365-S4 Appendix B_Test Plots

END OF REPORT