

APPENDIX I: LTE DOWNLINK ONLY CARRIER AGGREGATION TEST REDUCTION METHODOLOGY

SAR test exclusion for LTE downlink Carrier Aggregation is determined by power measurements according to the number of component carriers (CCs) supported by the product implementation. Per April 2018 TCBC Workshop Notes, the following test reduction methodology was applied to determine the combinations required for conducted power measurements.

LTE DLCA Test Reduction Methodology:

- The supported combinations were arranged by the number of component carriers in columns.
- Any limitations on the PCC or SCC for each combination were identified alongside the combination (e.g. CA_2A-2A-4A-12A, but B12 can only be configured as a SCC).
- Power measurements were performed for "supersets" (LTE CA combinations with multiple components carriers) and any "subsets" (LTE CA combinations with fewer component carriers) that were not completely covered by the supersets.
- Only subsets that have the exact same components as a superset were excluded for measurement.
- When there were certain restrictions on component carriers that existed in the superset that were not applied for the subset, the subset configuration was additionally evaluated.
- Both inter-band and intra-band downlink carrier aggregation scenarios were considered.
- Downlink CA combinations for SISO and 4x4 Downlink MIMO operations were measured independently, per May 2017 TCBC Workshop notes.

Table I-1 – Example of Exclusion Table for SISO Configurations

Index	CC	Supported Channel Bandwidth (MHz)				Restriction	Completely Covered by Measurement Superset	Index	CC	Supported Channel Bandwidth (MHz)				Restriction	Completely Covered by Measurement Superset	Index	CC	Supported Channel Bandwidth (MHz)				Restriction	Completely Covered by Measurement Superset
		CC1	CC2	CC3	CC4					CC1	CC2	CC3	CC4					CC1	CC2	CC3	CC4		
RCC#1	CA_2A	5, 10, 15, 20	5, 10, 15, 20				RCC#1	CA_2A	5, 10, 15, 20					RCC#1	CA_2A	5, 10, 15, 20							
RCC#2	CA_2A-2A	5, 10, 15, 20	5, 10, 15, 20				RCC#2	CA_2A-2A	5, 10, 15, 20	5, 10, 15, 20				RCC#2	CA_2A-2A	5, 10, 15, 20	5, 10, 15, 20						
RCC#3	CA_2A-2A-4A	5, 10, 15, 20	5, 10, 15, 20	5, 10, 15, 20			RCC#3	CA_2A-2A-4A	5, 10, 15, 20	5, 10, 15, 20	5, 10, 15, 20			RCC#3	CA_2A-2A-4A	5, 10, 15, 20	5, 10, 15, 20	5, 10, 15, 20					
RCC#4	CA_2A-2A-4A-12A	5, 10, 15, 20	5, 10, 15, 20	5, 10, 15, 20	5, 10, 15, 20		RCC#4	CA_2A-2A-4A-12A	5, 10, 15, 20	5, 10, 15, 20	5, 10, 15, 20	5, 10, 15, 20		RCC#4	CA_2A-2A-4A-12A	5, 10, 15, 20	5, 10, 15, 20	5, 10, 15, 20	5, 10, 15, 20				

Table I-2 – Example of Exclusion Table for 4x4 Downlink MIMO Configurations

Index	CC	Supported Channel Bandwidth (MHz)				Restriction	Completely Covered by Measurement Superset	Index	CC	Supported Channel Bandwidth (MHz)				Restriction	Completely Covered by Measurement Superset	Index	CC	Supported Channel Bandwidth (MHz)				Restriction	Completely Covered by Measurement Superset
		CC1	CC2	CC3	CC4					CC1	CC2	CC3	CC4					CC1	CC2	CC3	CC4		
RCC#M1	CA_12C	5, 10, 15, 20	5, 10, 15, 20				RCC#M1	CA_12C	5, 10, 15, 20	5, 10, 15, 20				RCC#M1	CA_12C	5, 10, 15, 20	5, 10, 15, 20						
RCC#M2	CA_12A-2A	5, 10, 15, 20	5, 10, 15, 20				RCC#M2	CA_12A-2A	5, 10, 15, 20	5, 10, 15, 20				RCC#M2	CA_12A-2A	5, 10, 15, 20	5, 10, 15, 20						
RCC#M3	CA_12A-12A	5, 10, 15, 20	5, 10, 15, 20				RCC#M3	CA_12A-12A	5, 10, 15, 20	5, 10, 15, 20				RCC#M3	CA_12A-12A	5, 10, 15, 20	5, 10, 15, 20						
RCC#M4	CA_12A-12A-12A	5, 10, 15, 20	5, 10, 15, 20	5, 10, 15, 20			RCC#M4	CA_12A-12A-12A	5, 10, 15, 20	5, 10, 15, 20	5, 10, 15, 20			RCC#M4	CA_12A-12A-12A	5, 10, 15, 20	5, 10, 15, 20	5, 10, 15, 20					
RCC#M5	CA_12A-12A-12A	5, 10, 15, 20	5, 10, 15, 20	5, 10, 15, 20	5, 10, 15, 20		RCC#M5	CA_12A-12A-12A	5, 10, 15, 20	5, 10, 15, 20	5, 10, 15, 20	5, 10, 15, 20		RCC#M5	CA_12A-12A-12A	5, 10, 15, 20	5, 10, 15, 20	5, 10, 15, 20	5, 10, 15, 20				

Note: [CC] indicates component carrier with 4x4 DL MIMO antenna configuration

I.1 LTE Downlink Only Carrier Aggregation Test Selection and Setup

SAR test exclusion for LTE downlink Carrier Aggregation is determined by power measurements according to the number component carriers (CCs) supported by the product implementation. For those

FCC ID: A3LSMA156U	SAR EVALUATION REPORT	Approved by: Technical Manager
DUT Type: Portable Handset		APPENDIX I: Page 1 of 6

configurations required by April 2018 TCBC Workshop Notes, conducted power measurements with LTE Carrier Aggregation (CA) (downlink only) active are made in accordance to KDB Publication 941225 D05Av01r02. The RRC connection is only handled by one cell, the primary component carrier (PCC) for downlink and uplink communications. After making a data connection to the PCC, the UE device adds secondary component carrier(s) (SCC) on the downlink only. All uplink communications and acknowledgements remain identical to specifications when downlink carrier aggregation is inactive on the PCC. Additional conducted output powers are measured with the downlink carrier aggregation active for the configuration with highest measured maximum conducted power with downlink carrier aggregation inactive measured among the channel bandwidth, modulation, and RB combinations in each frequency band.

Per FCC KDB Publication 941225 D05Av01r02, no SAR measurements are required for carrier aggregation configurations when the maximum average output power with downlink only carrier aggregation active is not more than 0.25 dB higher than the average output power with downlink only carrier aggregation inactive. All bands required for SAR testing per FCC KDB procedures were considered. Based on the measured maximum powers below, no additional SAR tests were required for DLCA SAR configurations.

General PCC and SCC configuration selection procedure

- PCC uplink channel, channel bandwidth, modulation and RB configurations were selected based on section C)3)b)ii) of KDB 941225 D05 V01r02. All LTE bandwidth conducted powers needed for PCC uplink configuration selection can be found in the RF Conducted Powers Section and LTE/NR Lower Bandwidth RF Conducted Power Appendix. The downlink PCC channel was paired with the selected PCC uplink channel according to normal configurations without carrier aggregation.
- To maximize aggregated bandwidth, highest channel bandwidth available for that CA combination was selected for SCC. For inter-band CA, the SCC downlink channels were selected near the middle of their transmission bands. For contiguous intra-band CA, the downlink channel spacing between the component carriers was set to multiple of 300 kHz less than the nominal channel spacing defined in section 5.4.1A of 3GPP TS 36.521. For non-contiguous intra-band CA, the downlink channel spacing between the component carriers was set to be larger than the nominal channel spacing and provided maximum separation between the component carriers.
- All selected PCC and SCC(s) remained fully within the uplink/downlink transmission band of the respective component carrier.

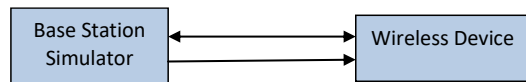

Figure I-1
DL CA Power Measurement Setup

FCC ID: A3LSMA156U	SAR EVALUATION REPORT	Approved by: Technical Manager
DUT Type: Portable Handset		APPENDIX I: Page 2 of 6

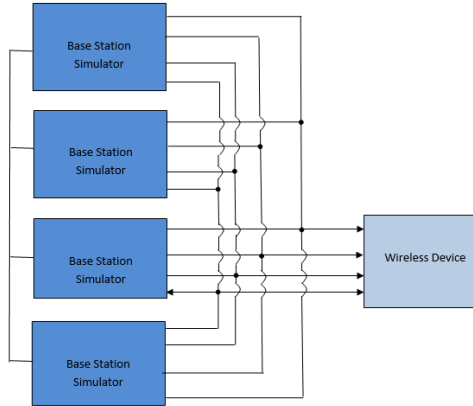

Figure I-2
DL CA with DL 4x4 MIMO Power Measurement Setup

I.2 Downlink Carrier Aggregation RF Conducted Powers

I.2.1 LTE Band 71 as PCC

Table I-3
Maximum Output Powers

Combination	PCC								SCC 1				Power		
	PCC Band	PCC BW [MHz]	PCC (UL) Ch.	PCC (UL) Freq. [MHz]	Mod.	PCC UL# RB	PCC UL RB Offset	PCC (DL) Channel	PCC (DL) Freq. [MHz]	SCC Band	SCC BW [MHz]	SCC (DL) Channel	SCC (DL) Freq. [MHz]	LTE Tx.Power with DL CA Enabled (dBm)	LTE Single Carrier Tx Power (dBm)
CA_2A-71A	LTE B71	10	133422	693	QPSK	1	49	68886	647	LTE B2	20	900	1960	24.54	24.39
CA_4A-71A	LTE B71	10	133422	693	QPSK	1	49	68886	647	LTE B4	20	2175	2132.5	24.52	24.39
CA_66A-71A	LTE B71	10	133422	693	QPSK	1	49	68886	647	LTE B66	20	66786	2145	24.55	24.39

I.2.2 LTE Band 12 as PCC

Table I-4
Maximum Output Powers

Combination	PCC								SCC 1				Power		
	PCC Band	PCC BW [MHz]	PCC (UL) Ch.	PCC (UL) Freq. [MHz]	Mod.	PCC UL# RB	PCC UL RB Offset	PCC (DL) Channel	PCC (DL) Freq. [MHz]	SCC Band	SCC BW [MHz]	SCC (DL) Channel	SCC (DL) Freq. [MHz]	LTE Tx.Power with DL CA Enabled (dBm)	LTE Single Carrier Tx Power (dBm)
CA_2A-12A (1)	LTE B12	5	23155	713.5	QPSK	1	24	5155	743.5	LTE B2	20	900	1960	24.61	24.68
CA_4A-12A (1)	LTE B12	5	23155	713.5	QPSK	1	24	5155	743.5	LTE B4	20	2175	2132.5	24.62	24.68
CA_4A-12A (2)	LTE B12	5	23155	713.5	QPSK	1	24	5155	743.5	LTE B4	20	2175	2132.5	24.62	24.68
CA_12B	LTE B12	5	23155	713.5	QPSK	1	24	5155	743.5	LTE B12	5	5107	738.7	24.64	24.68
CA_12A-25A	LTE B12	5	23155	713.5	QPSK	1	24	5155	743.5	LTE B25	20	8365	1962.5	24.69	24.68
CA_12A-30A	LTE B12	5	23155	713.5	QPSK	1	24	5155	743.5	LTE B30	10	9820	2355	24.68	24.68
CA_12A-48A	LTE B12	5	23155	713.5	QPSK	1	24	5155	743.5	LTE B48	20	55990	3625	24.71	24.68
CA_12A-66A (1)	LTE B12	5	23155	713.5	QPSK	1	24	5155	743.5	LTE B66	20	66786	2145	24.65	24.68
CA_12A-66A (2)	LTE B12	5	23155	713.5	QPSK	1	24	5155	743.5	LTE B66	20	66786	2145	24.65	24.68

I.2.3 LTE Band 13 as PCC

Table I-5
Maximum Output Powers

Combination	PCC								SCC 1				Power		
	PCC Band	PCC BW [MHz]	PCC (UL) Ch.	PCC (UL) Freq. [MHz]	Mod.	PCC UL# RB	PCC UL RB Offset	PCC (DL) Channel	PCC (DL) Freq. [MHz]	SCC Band	SCC BW [MHz]	SCC (DL) Channel	SCC (DL) Freq. [MHz]	LTE Tx.Power with DL CA Enabled (dBm)	LTE Single Carrier Tx Power (dBm)
CA_2A-13A (2)	LTE B13	10	23230	782	QPSK	1	49	5230	751	LTE B2	20	900	1960	23.62	23.48
CA_4A-13A	LTE B13	10	23230	782	QPSK	1	49	5230	751	LTE B4	20	2175	2132.5	23.62	23.48
CA_7A-13A	LTE B13	10	23230	782	QPSK	1	49	5230	751	LTE B7	20	3100	2655	23.63	23.48
CA_13A-48A	LTE B13	10	23230	782	QPSK	1	49	5230	751	LTE B48	20	55990	3625	23.47	23.48
CA_13A-66A	LTE B13	10	23230	782	QPSK	1	49	5230	751	LTE B66	20	66786	2145	23.61	23.48

FCC ID: A3LSMA156U	SAR EVALUATION REPORT	Approved by: Technical Manager
DUT Type: Portable Handset		APPENDIX I: Page 3 of 6

I.2.4 LTE Band 14 as PCC

Table I-6
Maximum Output Powers

Combination	PCC									SCC 1				Power	
	PCC Band	PCC BW [MHz]	PCC (UL) Ch.	PCC (UL) Freq. [MHz]	Mod.	PCC UL# RB	PCC UL RB Offset	PCC (DL) Channel	PCC (DL) Freq. [MHz]	SCC Band	SCC BW [MHz]	SCC (DL) Channel	SCC (DL) Freq. [MHz]	LTE Tx.Power with DL CA Enabled (dBm)	LTE Single Carrier Tx Power (dBm)
CA_2A-14A	LTE B14	10	23330	793	QPSK	1	0	5330	763	LTE B2	20	900	1960	23.66	23.53
CA_14A-30A	LTE B14	10	23330	793	QPSK	1	0	5330	763	LTE B30	10	9820	2355	23.67	23.53
CA_14A-66A	LTE B14	10	23330	793	QPSK	1	0	5330	763	LTE B66	20	66786	2145	23.66	23.53

I.2.5 LTE Band 26 as PCC

Table I-7
Maximum Output Powers

Combination	PCC									SCC 1				Power	
	PCC Band	PCC BW [MHz]	PCC (UL) Ch.	PCC (UL) Freq. [MHz]	Mod.	PCC UL# RB	PCC UL RB Offset	PCC (DL) Channel	PCC (DL) Freq. [MHz]	SCC Band	SCC BW [MHz]	SCC (DL) Channel	SCC (DL) Freq. [MHz]	LTE Tx.Power with DL CA Enabled (dBm)	LTE Single Carrier Tx Power (dBm)
CA_25A-26A	LTE B26	5	26865	831.5	QPSK	1	12	8865	876.5	LTE B25	20	8365	1962.5	24.73	24.61
CA_26A-41A	LTE B26	5	26865	831.5	QPSK	1	12	8865	876.5	LTE B41	20	40620	2593	24.76	24.61

I.2.6 LTE Band 66 as PCC

Table I-8
Maximum Output Powers

Combination	PCC									SCC 1				Power	
	PCC Band	PCC BW [MHz]	PCC (UL) Ch.	PCC (UL) Freq. [MHz]	Mod.	PCC UL# RB	PCC UL RB Offset	PCC (DL) Channel	PCC (DL) Freq. [MHz]	SCC Band	SCC BW [MHz]	SCC (DL) Channel	SCC (DL) Freq. [MHz]	LTE Tx.Power with DL CA Enabled (dBm)	LTE Single Carrier Tx Power (dBm)
CA_2A-66A	LTE B66	5	131997	1712.5	QPSK	1	12	66461	2112.5	LTE B2	20	900	1960	25.40	25.36
CA_5A-66A	LTE B66	5	131997	1712.5	QPSK	1	12	66461	2112.5	LTE B5	10	2525	881.5	25.30	25.36
CA_7A-66A	LTE B66	5	131997	1712.5	QPSK	1	12	66461	2112.5	LTE B7	20	3100	2655	25.32	25.36
CA_12A-66A (1)	LTE B66	5	131997	1712.5	QPSK	1	12	66461	2112.5	LTE B12	10	5095	737.5	25.43	25.36
CA_12A-66A (2)	LTE B66	5	131997	1712.5	QPSK	1	12	66461	2112.5	LTE B12	10	5095	737.5	25.43	25.36
CA_13A-66A	LTE B66	5	131997	1712.5	QPSK	1	12	66461	2112.5	LTE B13	10	5230	751	25.40	25.36
CA_14A-66A	LTE B66	5	131997	1712.5	QPSK	1	12	66461	2112.5	LTE B14	10	5330	763	25.38	25.36
CA_29A-66A	LTE B66	5	131997	1712.5	QPSK	1	12	66461	2112.5	LTE B29	10	9715	722.5	25.39	25.36
CA_30A-66A	LTE B66	5	131997	1712.5	QPSK	1	12	66461	2112.5	LTE B30	10	9820	2355	25.35	25.36
CA_66A-66A	LTE B66	5	131997	1712.5	QPSK	1	12	66461	2112.5	LTE B66	20	67236	2190	25.38	25.36
CA_66B	LTE B66	5	131997	1712.5	QPSK	1	12	66461	2112.5	LTE B66	15	66554	2121.8	25.42	25.36
CA_66C	LTE B66	5	131997	1712.5	QPSK	1	12	66461	2112.5	LTE B66	20	66578	2124.2	25.37	25.36
CA_66A-71A	LTE B66	5	131997	1712.5	QPSK	1	12	66461	2112.5	LTE B71	20	68761	634.5	25.39	25.36

I.2.7 LTE Band 25 as PCC

Table I-9
Maximum Output Powers

Combination	PCC									SCC 1				Power	
	PCC Band	PCC BW [MHz]	PCC (UL) Ch.	PCC (UL) Freq. [MHz]	Mod.	PCC UL# RB	PCC UL RB Offset	PCC (DL) Channel	PCC (DL) Freq. [MHz]	SCC Band	SCC BW [MHz]	SCC (DL) Channel	SCC (DL) Freq. [MHz]	LTE Tx.Power with DL CA Enabled (dBm)	LTE Single Carrier Tx Power (dBm)
CA_5A-25A	LTE B25	20	26365	1882.5	QPSK	1	0	8365	1962.5	LTE B5	10	2525	881.5	24.44	24.56
CA_12A-25A	LTE B25	20	26365	1882.5	QPSK	1	0	8365	1962.5	LTE B12	10	5095	737.5	24.59	24.56
CA_25A-25A (1)	LTE B25	20	26365	1882.5	QPSK	1	0	8365	1962.5	LTE B25	20	8140	1940	24.55	24.56
CA_25A-26A	LTE B25	3	26365	1882.5	QPSK	1	0	8365	1962.5	LTE B26	15	8865	876.5	24.86	24.82
CA_25A-41A	LTE B25	20	26365	1882.5	QPSK	1	0	8365	1962.5	LTE B41	20	40620	2593	24.42	24.56

FCC ID: A3LSMA156U	SAR EVALUATION REPORT	Approved by: Technical Manager
DUT Type: Portable Handset		APPENDIX I: Page 4 of 6

I.2.8 LTE Band 30 as PCC

Table I-10
Maximum Output Powers

Combination	PCC									SCC 1				Power	
	PCC Band	PCC BW [MHz]	PCC (UL) Ch.	PCC (UL) Freq. [MHz]	Mod.	PCC UL# RB	PCC UL RB Offset	PCC (DL) Channel	PCC (DL) Freq. [MHz]	SCC Band	SCC BW [MHz]	SCC (DL) Channel	SCC (DL) Freq. [MHz]	LTE Tx.Power with DL CA Enabled (dBm)	LTE Single Carrier Tx Power (dBm)
CA_2A-30A	LTE B30	5	27710	2310	QPSK	1	12	9820	2355	LTE B2	20	900	1960	22.62	22.53
CA_5A-30A	LTE B30	5	27710	2310	QPSK	1	12	9820	2355	LTE B5	10	2525	881.5	22.71	22.53
CA_12A-30A	LTE B30	5	27710	2310	QPSK	1	12	9820	2355	LTE B12	10	5095	737.5	22.73	22.53
CA_14A-30A	LTE B30	5	27710	2310	QPSK	1	12	9820	2355	LTE B14	10	5075	763	22.70	22.53
CA_29A-30A	LTE B30	5	27710	2310	QPSK	1	12	9820	2355	LTE B29	10	9715	722.5	22.69	22.53
CA_30A-66A	LTE B30	5	27710	2310	QPSK	1	12	9820	2355	LTE B66	20	66786	2145	22.68	22.53

I.2.1 LTE Band 7 as PCC

Table I-11
Maximum Output Powers

Combination	PCC									SCC 1				Power	
	PCC Band	PCC BW [MHz]	PCC (UL) Ch.	PCC (UL) Freq. [MHz]	Mod.	PCC UL# RB	PCC UL RB Offset	PCC (DL) Channel	PCC (DL) Freq. [MHz]	SCC Band	SCC BW [MHz]	SCC (DL) Channel	SCC (DL) Freq. [MHz]	LTE Tx.Power with DL CA Enabled (dBm)	LTE Single Carrier Tx Power (dBm)
CA_2A-7A	LTE B7	10	20800	2505	QPSK	1	0	2800	2625	LTE B2	20	900	1960	23.27	23.20
CA_7A-7A (1)	LTE B7	10	20800	2505	QPSK	1	0	2800	2625	LTE B7	20	3350	2680	23.39	23.20
CA_7C (1)	LTE B7	10	20800	2505	QPSK	1	0	2800	2625	LTE B7	20	2944	2639.4	23.37	23.20
CA_7A-13A	LTE B7	10	20800	2505	QPSK	1	0	2800	2625	LTE B13	10	5230	751	23.35	23.20
CA_7A-66A	LTE B7	10	20800	2505	QPSK	1	0	2800	2625	LTE B66	20	66786	2145	23.30	23.20

I.2.2 LTE Band 41 as PCC

Table I-12
Maximum Output Powers

Combination	PCC									SCC 1				Power	
	PCC Band	PCC BW [MHz]	PCC (UL) Ch.	PCC (UL) Freq. [MHz]	Mod.	PCC UL# RB	PCC UL RB Offset	PCC (DL) Channel	PCC (DL) Freq. [MHz]	SCC Band	SCC BW [MHz]	SCC (DL) Channel	SCC (DL) Freq. [MHz]	LTE Tx.Power with DL CA Enabled (dBm)	LTE Single Carrier Tx Power (dBm)
CA_41A-41A (1)	LTE B41	20	41490	2680	QPSK	1	50	41490	2680	LTE B41	20	39750	2506	24.56	24.70
CA_41C (1)	LTE B41	20	41490	2680	QPSK	1	50	41490	2680	LTE B41	20	41292	2660.2	24.73	24.70

I.2.3 LTE Band 48 as PCC

Table I-13
Maximum Output Powers

Combination	PCC									SCC 1				Power	
	PCC Band	PCC BW [MHz]	PCC (UL) Ch.	PCC (UL) Freq. [MHz]	Mod.	PCC UL# RB	PCC UL RB Offset	PCC (DL) Channel	PCC (DL) Freq. [MHz]	SCC Band	SCC BW [MHz]	SCC (DL) Channel	SCC (DL) Freq. [MHz]	LTE Tx.Power with DL CA Enabled (dBm)	LTE Single Carrier Tx Power (dBm)
CA_48A-48A	LTE B48	15	55765	3602.5	QPSK	1	0	55765	3602.5	LTE B48	20	56640	3690	22.80	22.83
CA_48B	LTE B48	15	55765	3602.5	QPSK	1	0	55765	3602.5	LTE B48	5	55858	3611.8	22.79	22.83
CA_48C	LTE B48	15	55765	3602.5	QPSK	1	0	55765	3602.5	LTE B48	20	55936	3619.6	22.76	22.83

FCC ID: A3LSMA156U	SAR EVALUATION REPORT	Approved by: Technical Manager
DUT Type: Portable Handset		APPENDIX I: Page 5 of 6

I.3 DL CA with DL 4x4 MIMO RF Conduction Powers

This device supports downlink 4x4 MIMO operations for some LTE bands. Uplink transmission is limited to a single output stream. When carrier aggregation was applicable, the general test selection and setup procedures described in Section I.1 were applied.

Per May 2017 TCB Workshop Notes, SAR for 4x4 DL MIMO was not needed since the maximum average output power in 4x4 DL MIMO mode was not more than 0.25 dB higher than the maximum output power with 4x4 DL MIMO inactive. Additionally, SAR for 4x4 MIMO Downlink Carrier Aggregation was not needed since the maximum average output power in 4x4 MIMO Downlink Carrier Aggregation mode was not more than 0.25 dB higher than the maximum output power with 4x4 MIMO Downlink and downlink carrier aggregation inactive.

I.3.1 LTE 4x4 MIMO DL Standalone Powers

Table I-14
Maximum Output Powers

LTE Band	Bandwidth [MHz]	Channel	Frequency [MHz]	Modulation	RB Size	RB Offset	4x4 DL MIMO Tx. Power [dBm]	Single Antenna Tx. Power [dBm]	Target Power [dBm]
66	5	131997	1712.5	QPSK	1	12	25.38	25.36	24.5
25	3	26365	1882.5	QPSK	1	0	24.79	24.82	24.5
41	20	41490	2680	QPSK	1	50	24.65	24.70	24.0
48	15	55765	3602.5	QPSK	1	0	22.77	22.83	23.0

FCC ID: A3LSMA156U	SAR EVALUATION REPORT	Approved by: Technical Manager
DUT Type: Portable Handset		APPENDIX I: Page 6 of 6