

EMI TEST REPORT FCC CERTIFICATION

Applicant:

SAMSUNG Electronics Co., Ltd.
129, Samsung-ro, Yeongtong-gu, Suwon-si,
Gyeonggi-do, 16677, Korea

Date of Issue: October 20, 2021

Test Report No. HCT-EM-2110-FC002

Test Site: HCT CO., LTD.

FCC ID :

A3LSMA136U

Rule Part(s) / Standard(s) : 47 CFR PART 15 Subpart B Class B
ANSI C63.4-2014
Product Name : Mobile phone
Model Name : SM-A136U
Series Model Name : SM-A136U1, SM-S136DL
Date of Test : October 13, 2021 to October 19, 2021

The device bearing the trade name and model specified above, has been shown to comply with the applicable technical standards as indicated in the measurement report and was tested in accordance with the measurement procedures specified in ANSI C63.4-2014. (See Test Report if any modifications were made for compliance)

I attest to the accuracy of data. All measurements reported herein were performed by me or were made under my supervision and are correct to the best of my knowledge and belief. I assume full responsibility for the completeness of these measurements and vouch for the qualifications of all persons taking them.

Tested By



Geon-Hee Jeon
Test Engineer
EMC Team
Certification Division

Reviewed



Jeong-Hyun Choi
Technical Manager
EMC Team
Certification Division

This report only responds to the tested sample and may not be reproduced, except in full, without written approval of the HCT Co., Ltd.



REVISION HISTORY

The revision history for this document is shown in table.

Rev No.	Issue Date	Information About Changes
0	October 20, 2021	Initial Release

The above Test Report is not related to the accredited test result by (KS Q) ISO/IEC 17025 and KOLAS (Korea Laboratory Accreditation Scheme), which signed the ILAC-MRA.

If this report is required to confirmation of authenticity, please contact to www.hct.co.kr



TABLE OF CONTENTS

	PAGE
1. GENERAL INFORMATION.....	4
1.1 Description of EUT.....	4
1.2 Tested System Details	4
1.3 Cable Description.....	5
1.4 Noise Suppression Parts on Cable. (I/O Cable)	5
1.5 Test Facility.....	6
1.6 Calibration of Measuring Instrument	6
1.7 Measurement Uncertainty	6
2. LIST OF TEST EQUIPMENT.....	7
3. DESCRIPTION OF TEST	8
3.1 Measurement of Conducted Emission.....	8
3.2 Measurement of Radiated Emission.....	9
3.3 Configuration of Tested System	10
4. OPERATION OF THE EUT	11
4.1 Conducted Emission (Not Applicable).....	11
4.2 Radiated Emission	11
5. CONDUCTED AND RADIATED EMISSION TEST SUMMARY	13
5.1 Conducted Emission (Not Applicable).....	13
5.2 Radiated Emission	14
6. CONCLUSION.....	23
7. APPENDIX A. TEST SETUP PHOTO.....	24



1. GENERAL INFORMATION

1.1 Description of EUT

FCC ID	A3LSMA136U
Model Name	SM-A136U
Series Model Name	SM-A136U1, SM-S136DL
Product Name	Mobile phone
Frequency Band	GSM 850/1900, WCDMA B2/4/5, LTE B2/4/5/7/12/13/14/25/26/29(Rx only)/30/38/40/41(PC3, PC2)/48/66/71, NR n2/5/25/41(PC3, PC2)/66/71/77(PC3, PC2(SA)), BT, WLAN a/b/g/n/ac, NFC
Power Supply	Travel adaptor: Input: AC 100 to 240 V, 50 to 60 Hz, 0.7 A Output: (PDO) 5.0 V, 3.0 A or 9.0 V, 2.77 A (PPS) 3.3 to 5.9 V, 3.0 A or 3.3 to 11.0 V, 2.25 A

1.2 Tested System Details

All equipment descriptions used in the tested system (including inserted cards) are:

Device Type	Model Name	Serial Number	Manufacturer
Mobile phone	SM-A136U	-	SAMSUNG
TA	EP-TA800	-	RF TECH
Data Cable	EP-DN980	-	RF TECH
Earphone	EHS64AV	-	ALMUS
Micro SD Card	-	-	SAMSUNG



1.3 Cable Description

Product Name	Port	Power Cord Shielded (Y/N)	I/O Cable Shielded (Y/N)	Length (m)
EUT	Data Cable (USB Type C)	Y	N/A	(P) 1.0
	Earphone	N/A	N	(D) 1.3

"(D)" Data Cable and "(P)" Power Cable.

1.4 Noise Suppression Parts on Cable. (I/O Cable)

Product Name	Port	Ferrite Bead (Y/N)	Location	Metal Hood (Y/N)	Location
EUT	Data Cable (USB Type C)	N	N/A	Y	Both End
	Earphone	N	N/A	Y	EUT End



1.5 Test Facility

Test site is located at 74, Seoicheon-ro 578beon-gil, Majang-myeon, Icheon-si, Gyeonggi-do, Korea. Those measurement facilities are constructed in conformance with the requirements of ANSI C63.4-2014. The Normalized site attenuations (30 MHz to 1 GHz) and Site validation (1 GHz to 18 GHz) were performed in accordance with the standard in ANSI C63.4a-2017.

Our laboratories are accredited and designated in accordance with the provisions of Radio Waves ACT and International Standard ISO/IEC 17025:2017. (National Radio Research Agency, Designation No. KR0032)

1.6 Calibration of Measuring Instrument

The measuring equipment, which was utilized in performing the tests documented herein, has been calibrated in accordance with the manufacturers recommendations for utilizing calibration equipment, which is traceable to recognized national standards.

Especially, all antenna for measurement is calibrated in accordance with the requirements of C63.5:2017.

1.7 Measurement Uncertainty

The measurement uncertainties shown below were calculated in accordance with the requirements of ANSI C63.4-2014.

All measurement uncertainty values are shown with a coverage factor of $k = 2$ to indicate a 95 % level of confidence. The measurement data shown herein meets or exceeds the U_{CISPR} measurement uncertainty values specified in CISPR 16-4-2 and, thus, can be compared directly to specified limits to determine compliance.

Test Item	Test Site (Chamber)	Expanded Uncertainty
Radiated Emission (30 MHz to 1 GHz)	3 m Semi Anechoic Chamber #1	5.8 dB
Radiated Emission (1 GHz to 18 GHz)	3 m Semi Anechoic Chamber #1	4.8 dB
Radiated Emission (18 GHz to 40 GHz)	3 m Semi Anechoic Chamber #1	5.8 dB



2. LIST OF TEST EQUIPMENT

<u>Type</u>	<u>Model Name</u>	<u>Manufacturer</u>	<u>Serial Number</u>	<u>Calibration Cycle</u>	<u>Calibration Date</u>
<u>Conducted Emission</u>					
<input type="checkbox"/> EMI Test Receiver	ESR7	Rohde & Schwarz	101910	1 year	06.17.2021
<input type="checkbox"/> LISN	ENV216	Rohde & Schwarz	102245	1 year	08.23.2021
<input type="checkbox"/> Radio communication analyzer	MT8821C	ANRITSU	6262192376	1 year	12.24.2020
<input type="checkbox"/> Antenna (for Communication)	USLP9142	Schwarzbeck	USLP 9142-200	N/A	-
<input type="checkbox"/> Radio communication analyzer	MT8000A	ANRITSU	6262208294	1 year	12.24.2020
<input type="checkbox"/> Antenna (for Communication)	USLP9142	Schwarzbeck	USLP 9142-201	N/A	-
<input type="checkbox"/> Software	EMC32	Rohde & Schwarz	-	-	-
<u>Radiated Emission</u>					
-For measurement below 1 GHz					
<input checked="" type="checkbox"/> EMI Test Receiver	ESU40	Rohde & Schwarz	100524	1 year	05.10.2021
<input checked="" type="checkbox"/> Bi-Log Antenna	VULB9168	Schwarzbeck	255	2 year	03.15.2021
<input checked="" type="checkbox"/> Antenna master	MA4640-XP-ET	INNCO SYSTEM	-	N/A	-
<input checked="" type="checkbox"/> Antenna master controller	CO3000	INNCO SYSTEM	CO3000/870/ 35990515/L	N/A	-
<input checked="" type="checkbox"/> Turn Table	1060	INNCO SYSTEM	-	N/A	-
<input checked="" type="checkbox"/> Turn Table controller	CO2000	INNCO SYSTEM	CO2000/095/ 7590304/L	N/A	-
<input checked="" type="checkbox"/> UNIVERSAL RADIO COMMUNICATION TESTER	CMU200	Rohde & Schwarz	106479	1 year	08.12.2021
<input checked="" type="checkbox"/> Radio communication analyzer	MT8821C	ANRITSU	6261991084	1 year	06.04.2021
<input checked="" type="checkbox"/> Antenna (for Communication)	HyperLOG7060	Aaronia	66450	-	-
<input checked="" type="checkbox"/> Radio communication analyzer	MT8000A	ANRITSU	6262208294	1 year	12.24.2020
<input checked="" type="checkbox"/> Antenna (for Communication)	HyperLOG7060	Aaronia	66451	-	-
<input checked="" type="checkbox"/> Software	EMC32	Rohde & Schwarz	-	-	-
-For measurement above 1 GHz					
<input checked="" type="checkbox"/> EMI Test Receiver	ESU40	Rohde & Schwarz	100524	1 year	05.10.2021
<input checked="" type="checkbox"/> Antenna master	MA4640-XP-ET	INNCO SYSTEM	-	N/A	-
<input checked="" type="checkbox"/> Antenna master controller	CO3000	INNCO SYSTEM	CO3000/870/ 35990515/L	N/A	-
<input checked="" type="checkbox"/> Turn Table	1060	INNCO SYSTEM	-	N/A	-
<input checked="" type="checkbox"/> Turn Table controller	CO2000	INNCO SYSTEM	CO2000/095/ 7590304/L	N/A	-
<input checked="" type="checkbox"/> Low Noise Amplifier	TK-PA18H	TESTEK	170034-L	1 year	03.02.2021
<input checked="" type="checkbox"/> Low Noise Amplifier	TK-PA1840H	TESTEK	170030-L	1 year	03.09.2021
<input checked="" type="checkbox"/> Horn Antenna	BBHA 9120D	Schwarzbeck	01836	1 year	07.20.2021
<input checked="" type="checkbox"/> Horn Antenna	BBHA 9170	Schwarzbeck	BBHA 9170 #786	1 year	11.18.2020
<input checked="" type="checkbox"/> Radio communication analyzer	MT8821C	ANRITSU	6261991084	1 year	06.04.2021
<input checked="" type="checkbox"/> Antenna (for Communication)	HyperLOG7060	Aaronia	66450	-	-
<input checked="" type="checkbox"/> Radio communication analyzer	MT8000A	ANRITSU	6262208294	1 year	12.24.2020
<input checked="" type="checkbox"/> Antenna (for Communication)	HyperLOG7060	Aaronia	66451	-	-
<input checked="" type="checkbox"/> Software	EMC32	Rohde & Schwarz	-	-	-



3. DESCRIPTION OF TEST

3.1 Measurement of Conducted Emission

The test procedure was in accordance with ANSI C63.4-2014, Clause 7.3

- a. The EUT was placed 0.4 meters from the conducting wall of the shielded room with EUT being connected to the power mains through a line impedance stabilization network (LISN).
If the EUT is connected to the PC through USB, the AC power-line adapter of the PC is directly connected to a line impedance stabilization network (LISN).
Other support units were connected to the power mains through another LISN. The two LISNs provide 50 Ohm/50uH of coupling impedance for the measuring instrument.
- b. Both conducted lines are measured in Quasi-Peak and Average mode, including the worst-case data points for each tested configuration.
- c. The frequency ranges from 150 kHz to 30 MHz was searched.

[Conducted Emission Limits]

Frequency (MHz)	Resolution Bandwidth (kHz)	Quasi-Peak (dB(μ V))	Average (dB(μ V))
0.15 to 0.5	9	66 to 56*	56 to 46*
0.5 to 5	9	56	46
5 to 30	9	60	50

**Decreases with the logarithm of the frequency.*



3.2 Measurement of Radiated Emission

The test procedure was in accordance with ANSI C63.4-2014, Clause 8.3

- a. The EUT was placed on the top of a turn table 0.8 meters above the ground at a semi-anechoic chamber. The table was rotated 360 degrees to determine the position of the highest radiation.
- b. The EUT was set 3 m away from the interference-receiving antenna, which was mounted on the top of a variable-height antenna tower.
- c. The antenna height is varied from 1 m to 4 m above the ground to determine the maximum value of the field strength. Both horizontal and vertical polarizations of the antenna are set to make the measurement.
- d. For each suspected emission, the EUT was arranged to its worst case and then the antenna was tuned to heights from 1 m to 4 m and the turn table was turned from 0 degrees to 360 degrees to find the maximum reading.
- e. The test-receiver system was set to Quasi-Peak detect function and specified bandwidth with maximum hold mode when the test frequency is below 1 GHz.
- f. The test-receiver system was set to Peak and Average detect function and specified bandwidth with maximum hold mode when the test frequency is above 1 GHz.
- g. Place the measurement antenna away from each area of the EUT determined to be a source of emissions at the specified measurement distance, while keeping the measurement antenna aimed at the source of emissions at each frequency of significant emissions, with polarization oriented for maximum response. (1 GHz to 40 GHz)

[Radiated Emission Limits]

Frequency (MHz)	Antenna Distance (m)	Field Strength ($\mu\text{V}/\text{m}$)	Quasi-Peak (dB $\mu\text{V}/\text{m}$)
30 to 88	3	100	40.0
88 to 216	3	150	43.5
216 to 960	3	200	46.0
Above 960	3	500	54.0
Frequency (MHz)	Antenna Distance (m)	Peak (dB $\mu\text{V}/\text{m}$)	Average (dB $\mu\text{V}/\text{m}$)
Above 1 000	3	74	54



3.2.1 Frequency Range of Radiated Measurements

An unintentional radiator, including a digital device, the spectrum shall be investigated from the lowest radio frequency signal generated or used in the device, without going below the lowest frequency for which a Radiated Emission limit is specified, up to the frequency shown in the following table.

Highest frequency generated or used in the device or on which the device operates or tunes (MHz)	Upper frequency of measurement range (MHz)
Below 1.705	30
1.705 to 108	1 000
108 to 500	2 000
500 to 1 000	5 000
Above 1 000	5 th harmonic of the highest frequency or 40 GHz, whichever is lower

3.3 Configuration of Tested System

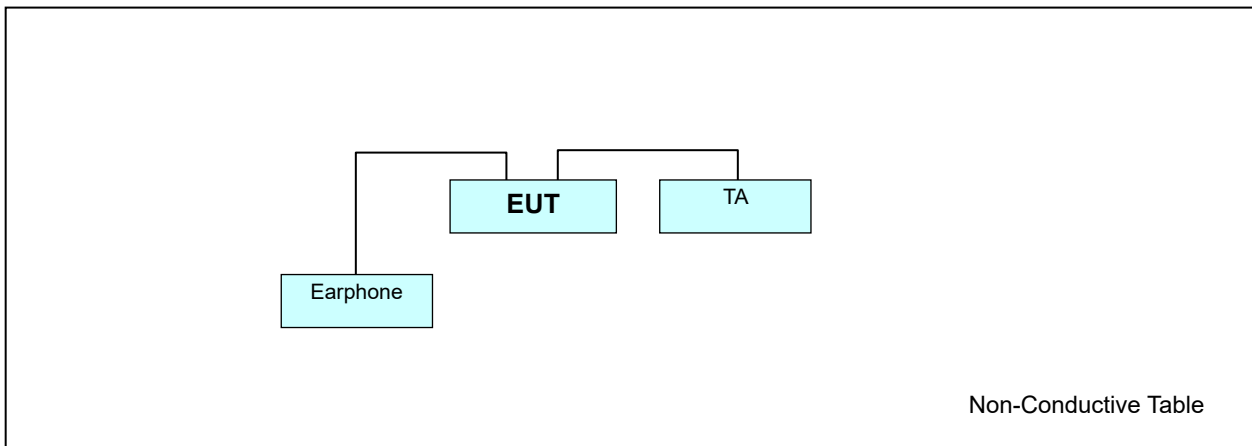



4. OPERATION OF THE EUT

During preliminary tests, the following operating mode was investigated.

Receiver mode(GSM 850 Low/Middle/High ch Idle)
 Receiver mode(WCDMA B5 Low/Middle/High ch Idle)
 Receiver mode(LTE B5_Low/Middle/High ch)
 Receiver mode(LTE B12_Low/Middle/High ch)
 Receiver mode(LTE B13_Low/Middle/High ch)
 Receiver mode(LTE B14_Low/Middle/High ch)
 Receiver mode(LTE B26_Low/Middle/High ch)
 Receiver mode(LTE B29_Low/Middle/High ch)
 Receiver mode(LTE B71_Low/Middle/High ch)
 Receiver mode(5G NR SA/NSA n5_Low/Middle/High ch)
 Receiver mode(5G NR SA/NSA n71_Low/Middle/High ch)

NOTE. The worst band is tested.

4.1 Conducted Emission (Not Applicable)

It was final tested the following operating mode, after connecting all peripheral devices.

Operating Mode: Not Applicable

4.2 Radiated Emission

It was final tested the following operating mode, after connecting all peripheral devices.

Operating Mode:

Radiated Emission below 1 GHz : LTE B26+B5+5G NR n5 Low ch Idle
 LTE B26+B5+5G NR n5 Middle ch Idle*
 LTE B26+B5+5G NR n5 High ch Idle
 LTE B12+B13 Low ch Idle
 LTE B12+B13 Middle ch Idle*
 LTE B12+B13 High ch Idle
 LTE B14 Low ch Idle
 LTE B14 Middle ch Idle*
 LTE B14 High ch Idle
 LTE B29 Low ch Idle
 LTE B29 Middle ch Idle*
 LTE B29 High ch Idle
 LTE B71+5G NR n71 Low ch Idle
 LTE B71+5G NR n71 Middle ch Idle*
 LTE B71+5G NR n71 High ch Idle



Radiated Emission above 1 GHz : LTE B26+B5+5G NR n5 Middle ch Idle
LTE B12+B13 Middle ch Idle*
LTE B14 Middle ch Idle
LTE B29 Middle ch Idle
LTE B71+5G NR n71 Middle ch Idle

NOTE.

1. Three orientations have been investigated and the worst case orientation (x-axis: The display of EUT placed on the table is facing upwards) is reported.
2. The worst case of operating mode is reported. [*].



5. CONDUCTED AND RADIATED EMISSION TEST SUMMARY

5.1 Conducted Emission (Not Applicable)

The test results of conducted emission at mains ports provide the following information:

Used Test Standard	47 CFR PART 15 Subpart B Class B ANSI C63.4-2014
Frequency Range	150 kHz to 30 MHz
Detector	Quasi-Peak, CISPR-Average
Bandwidth	9 kHz (6 dB)
Operating Mode	Not applicable
Test Site	EMI Shield Room
Temperature	- °C
Relative Humidity	- %
Test Date	-

- Calculation Formula:

1. Conductor L1 = Hot, Conductor N = Neutral
2. Corr. = LISN Factor + Cable Loss
3. QuasiPeak or CAverage= Receiver Reading + Corr.
4. Margin = Limit – QuasiPeak or CAverage



5.2 Radiated Emission

5.2.1 For Measurement Below 1 GHz

The test results of radiated emission provide the following information:

Used Test Standard	47 CFR PART 15 Subpart B Class B ANSI C63.4-2014
Frequency Range	30 MHz to 1 000 MHz
Detector	Quasi-Peak
Bandwidth	120 kHz (6 dB)
Worst Case of Operating Mode	LTE B26+B5+5G NR n5 Middle ch Idle LTE B12+B13 Middle ch Idle LTE B14 Middle ch Idle LTE B29 Middle ch Idle LTE B71+5G NR n71 Middle ch Idle
Measurement Distance	3 m
Test Site	3 m Semi Anechoic Chamber #1
Temperature	min. 23.2 °C, max. 25.6 °C
Humidity	min. 48.5 % R.H., max. 58.3 % R.H.
Test Date	October 13 to October 19, 2021

- Calculation Formula:

1. POL. H = Horizontal, POL. V = Vertical
2. QuasiPeak = Reading (Receiver Reading) + Corr.
3. Corr. (Correction Factor) = Antenna Factor + Cable Loss
4. Margin = Limit - QuasiPeak



Figure 1: Radiated Emission (30 MHz to 1 GHz), LTE B26+B5+5G NR n5 Middle ch Idle

FCC PART 15 CLASS B

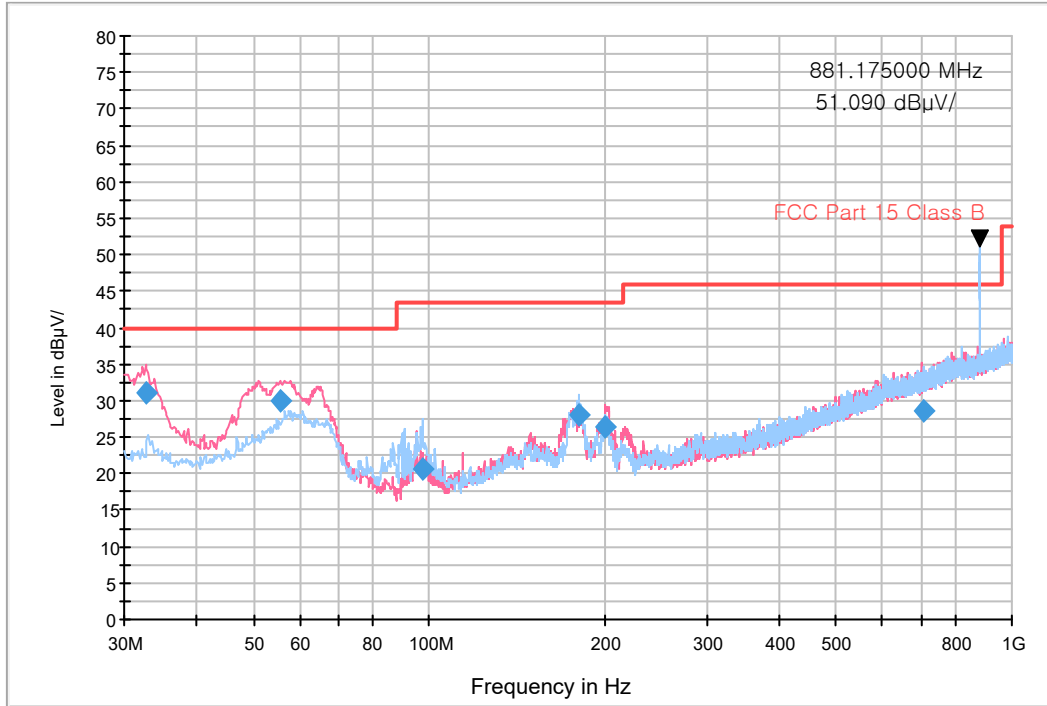

- NOTE. 1. Carrier Frequency: RX 881.175 MHz
 2. These are signals for fundamental frequency from the base station

Frequency (MHz)	Quasi Peak (dBµV/m)	Antenna Height (cm)	POL. (H/V)	Azimuth (deg)	Corr. (dB)	Margin (dB)	Limit (dBµV/m)
32.6275	31.0	100.0	V	212.0	18.7	9.0	40.0
55.4061	30.0	100.0	V	84.0	19.8	10.0	40.0
97.7219	20.5	225.1	H	348.0	14.9	23.0	43.5
180.8552	28.0	174.8	H	16.0	18.2	15.5	43.5
200.9502	26.3	100.0	V	120.0	16.8	17.2	43.5
708.1593	28.5	100.0	H	240.0	28.8	17.5	46.0



Figure 2: Radiated Emission (30 MHz to 1 GHz), LTE B12+B13 Middle ch Idle

FCC PART 15 CLASS B

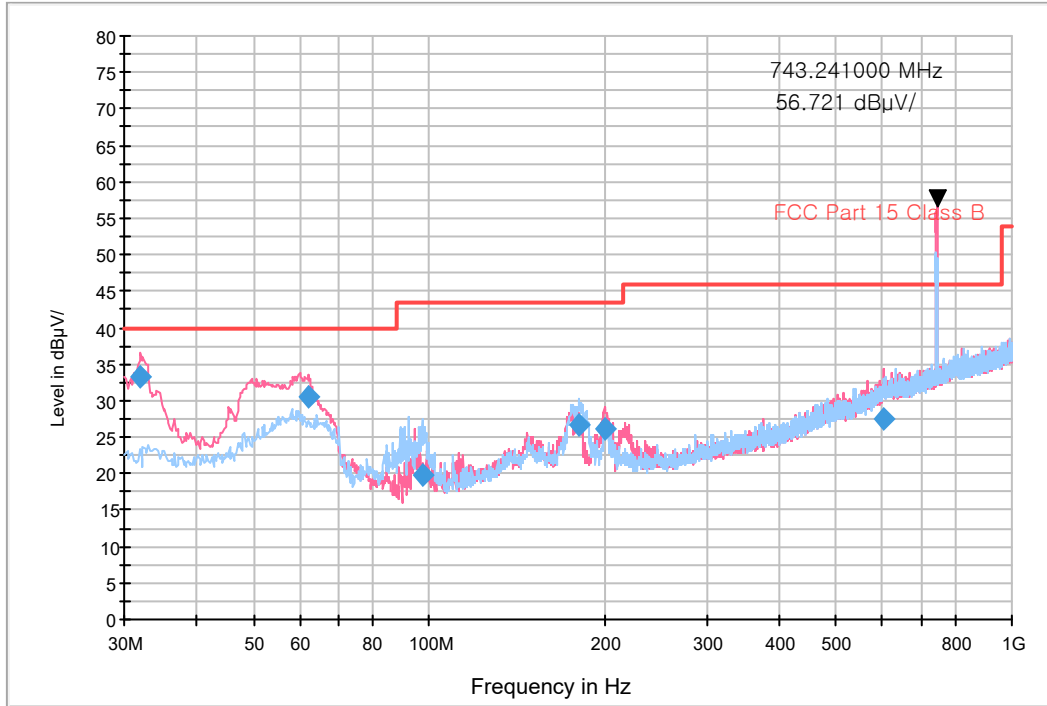

- NOTE. 1. Carrier Frequency: RX 743.241 MHz
 2. These are signals for fundamental frequency from the base station

Frequency (MHz)	Quasi Peak (dBµV/m)	Antenna Height (cm)	POL. (H/V)	Azimuth (deg)	Corr. (dB)	Margin (dB)	Limit (dBµV/m)
32.0788	33.2	100.0	V	214.0	18.6	6.8	40.0
62.0950	30.4	100.0	V	237.0	19.3	9.6	40.0
97.2335	19.8	225.3	H	344.0	14.8	23.7	43.5
180.6922	26.7	100.0	H	1.0	18.2	16.8	43.5
200.8390	26.0	100.0	V	79.0	16.8	17.5	43.5
603.9064	27.5	100.0	V	276.0	27.5	18.5	46.0



Figure 3: Radiated Emission (30 MHz to 1 GHz), LTE B14 Middle ch Idle

FCC PART 15 CLASS B

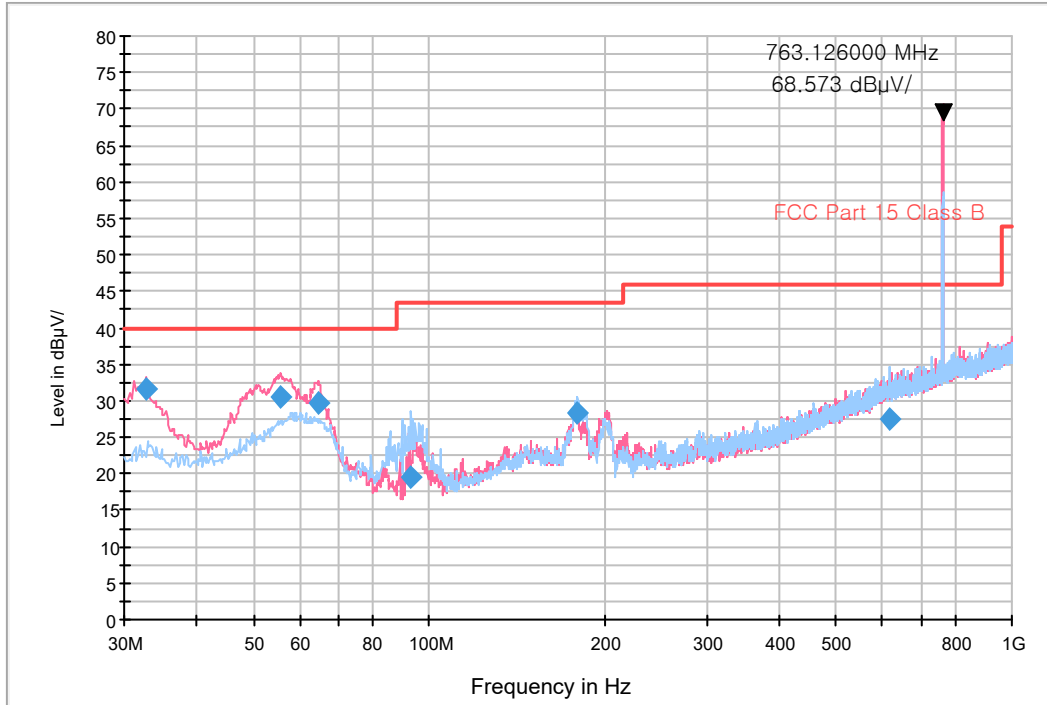

- NOTE. 1. Carrier Frequency: RX 763.126 MHz
 2. These are signals for fundamental frequency from the base station

Frequency (MHz)	Quasi Peak (dBµV/m)	Antenna Height (cm)	POL. (H/V)	Azimuth (deg)	Corr. (dB)	Margin (dB)	Limit (dBµV/m)
32.6646	31.6	100.0	V	223.0	18.7	8.4	40.0
55.6787	30.6	100.0	V	80.0	19.8	9.4	40.0
64.7183	29.8	100.0	V	232.0	18.9	10.2	40.0
93.2057	19.5	209.7	H	117.0	14.5	24.0	43.5
180.1689	28.4	125.0	H	16.0	18.3	15.1	43.5
615.9974	27.6	275.0	H	270.0	27.6	18.4	46.0



Figure 4: Radiated Emission (30 MHz to 1 GHz), LTE B29 Middle ch Idle

FCC PART 15 CLASS B

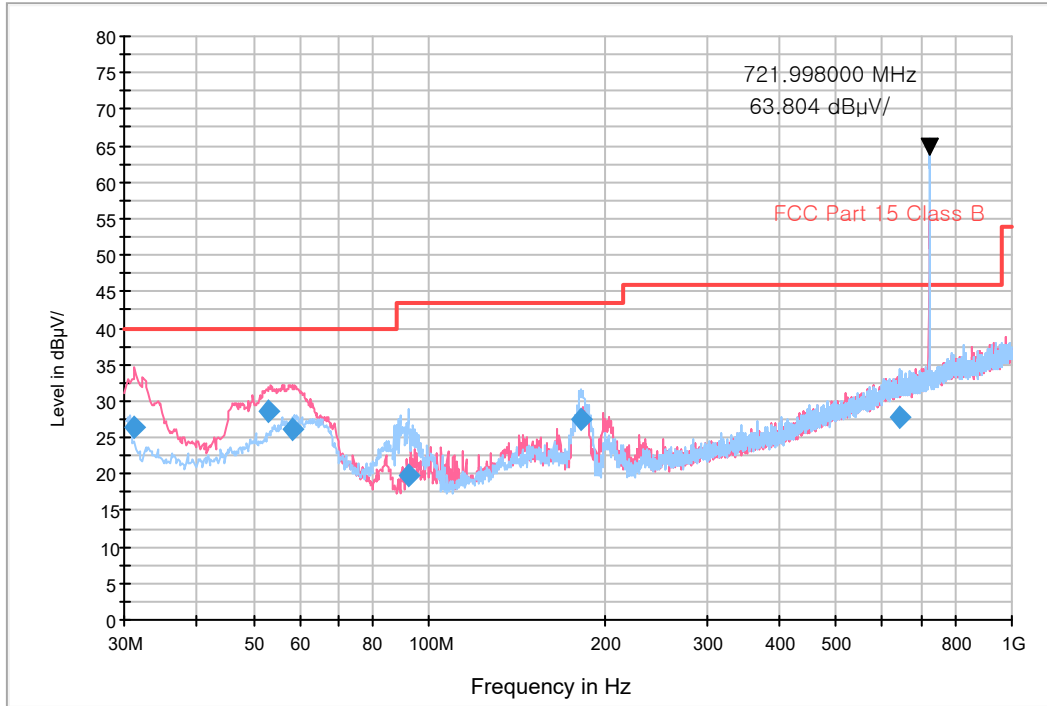

- NOTE. 1. Carrier Frequency: RX 721.998 MHz
 2. These are signals for fundamental frequency from the base station

Frequency (MHz)	Quasi Peak (dB μ V/m)	Antenna Height (cm)	POL. (H/V)	Azimuth (deg)	Corr. (dB)	Margin (dB)	Limit (dB μ V/m)
31.2508	26.3	100.0	V	31.0	18.6	13.7	40.0
53.2120	28.5	100.0	V	70.0	19.9	11.5	40.0
58.1860	26.2	100.0	V	48.0	19.7	13.8	40.0
92.3205	19.8	174.8	H	0.0	14.4	23.7	43.5
181.8414	27.4	117.7	H	17.0	18.2	16.1	43.5
641.1286	27.7	274.8	H	7.0	27.9	18.3	46.0



Figure 5: Radiated Emission (30 MHz to 1 GHz), LTE B71+5G NR n71 Middle ch Idle

FCC PART 15 CLASS B

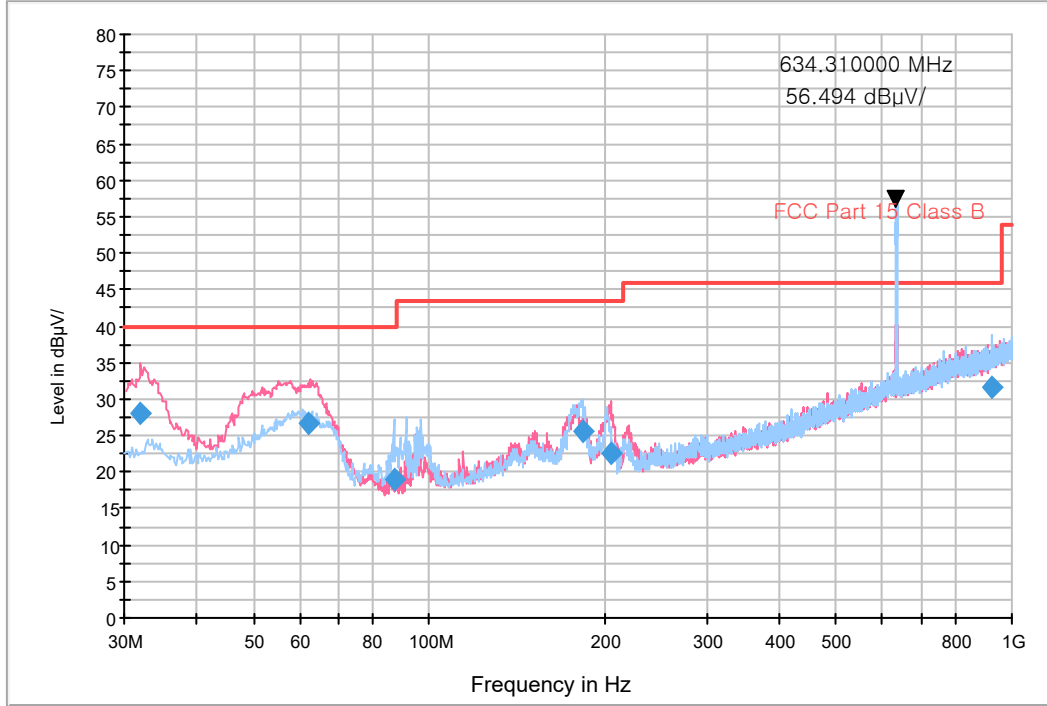

- NOTE. 1. Carrier Frequency: RX 634.310 MHz
 2. These are signals for fundamental frequency from the base station

Frequency (MHz)	Quasi Peak (dBµV/m)	Antenna Height (cm)	POL. (H/V)	Azimuth (deg)	Corr. (dB)	Margin (dB)	Limit (dBµV/m)
32.0168	28.0	100.0	V	85.0	18.6	12.0	40.0
62.3524	26.6	116.8	V	225.0	19.3	13.4	40.0
87.2395	19.1	191.7	H	126.0	14.6	20.9	40.0
184.1135	25.6	174.8	H	7.0	18.0	17.9	43.5
204.9619	22.6	100.0	V	144.0	17.0	20.9	43.5
925.6378	31.5	100.0	H	316.0	31.7	14.5	46.0



5.2.2 For Measurement Above 1 GHz

The test results of radiated emission provide the following information:

Used Test Standard	47 CFR PART 15 Subpart B Class B ANSI C63.4-2014
Detector	Peak mode: Peak (RBW: 1 MHz, VBW: 3 MHz) CISPR-Average mode: Peak (RBW: 1 MHz, VBW: 10 Hz)
Highest Frequency	5 825 MHz
Tested Frequency Range	1 GHz to 30 GHz
Worst Case of Operating Mode	LTE B12+B13 Middle ch Idle
Measurement Distance	3 m
Test Site	3 m Semi Anechoic Chamber #1
Temperature	min. 23.4 °C, max. 25.1 °C
Humidity	min. 48.5 % R.H., max. 54.3 % R.H.
Test Date	October 18 / October 19, 2021

- Calculation Formula:

1. POL. H = Horizontal, POL. V = Vertical
2. Peak or CAverage = Reading (Receiver Reading) + Corr.
3. Corr. (Correction Factor) = Antenna Factor+ Cable Loss –Amplifier Gain
4. Margin = Limit - Peak or CAverage



Figure 6: Radiated Emission (1 GHz to 30 GHz), LTE B12+B13 Middle ch Idle

Tilting of GHz FCC PART 15 CLASS B

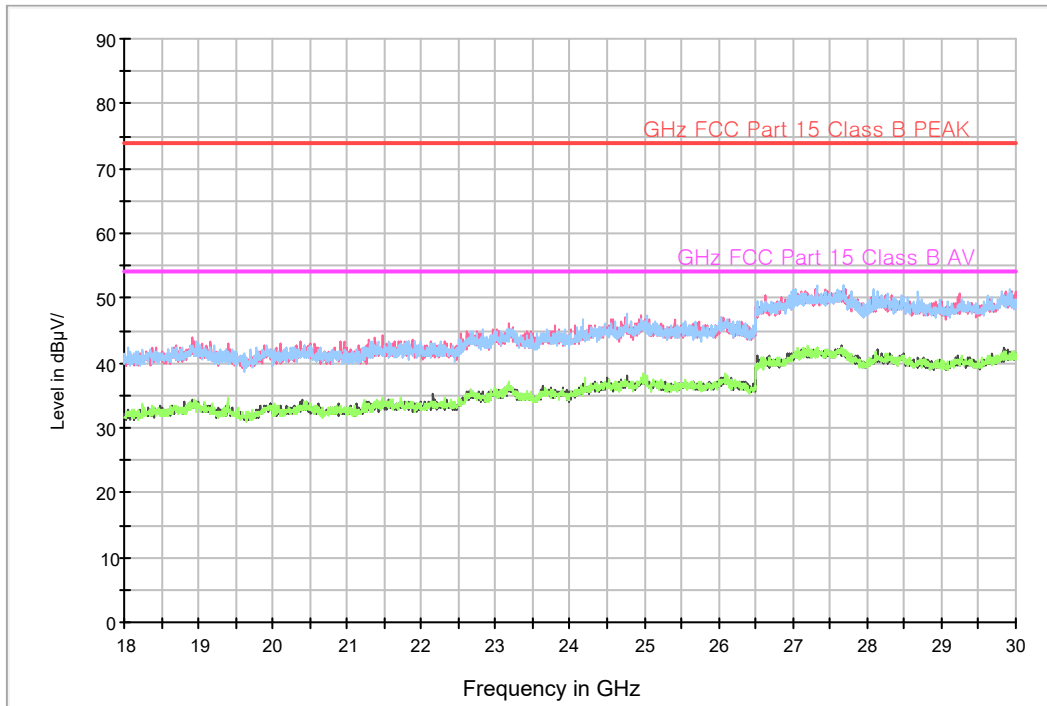
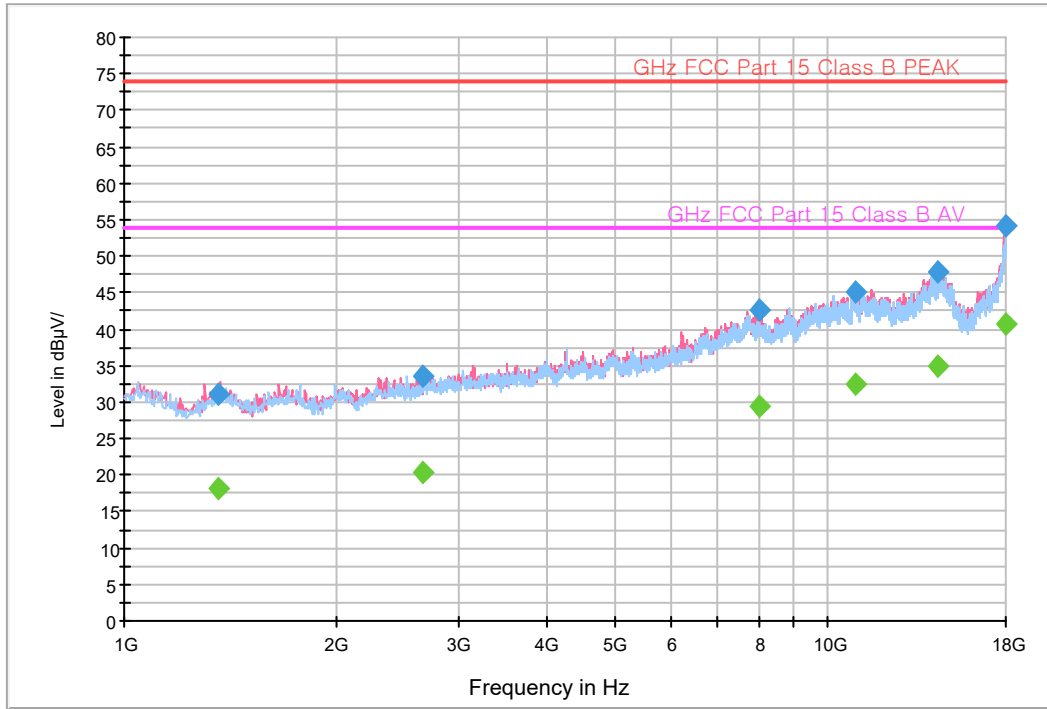



Frequency (MHz)	Peak (dB μ V/m)	Antenna Height (cm)	POL. (H/V)	Azimuth (deg)	Corr. (dB)	Margin (dB)	Limit (dB μ V/m)
1358.4250	31.1	349.8	V	70.0	-27.2	42.9	74.0
2669.7650	33.5	137.8	V	209.0	-22.7	40.5	74.0
8027.2100	42.6	100.0	V	4.0	-10.4	31.4	74.0
1 1030.6300	45.0	150.0	V	95.0	-4.4	29.0	74.0
1 4425.4750	47.9	161.6	V	310.0	0.3	26.1	74.0
1 7979.1825	54.2	160.7	V	338.0	9.2	19.8	74.0

Frequency (MHz)	CAverage (dB μ V/m)	Antenna Height (cm)	POL. (H/V)	Azimuth (deg)	Corr. (dB)	Margin (dB)	Limit (dB μ V/m)
1358.4250	18.1	349.8	V	70.0	-27.2	35.9	54.0
2669.7650	20.4	137.8	V	209.0	-22.7	33.6	54.0
8027.2100	29.5	100.0	V	4.0	-10.4	24.5	54.0
1 1030.6300	32.5	150.0	V	95.0	-4.4	21.5	54.0
1 4425.4750	35.0	161.6	V	310.0	0.3	19.0	54.0
1 7979.1825	40.8	160.7	V	338.0	9.2	13.2	54.0



6. CONCLUSION

The data collected shows that the **Product Name: Mobile phone and Model Name: SM-A136U** complies with §15.107 and §15.109 of the FCC rules.



7. APPENDIX A. TEST SETUP PHOTO

Please refer to EMI Test Setup Photo and test setup photo file no. as follows;

Rev. No.	Issue Date	File No.
0	October 20, 2021	HCT-EM-2110-FC002-P

End of report