



CERTIFICATION TEST REPORT

Report Number. : 4790215265-E6V3

Applicant : SAMSUNG ELECTRONICS CO., LTD.
129 SAMSUNG-RO, YEONGTONG-GU, SUWON-SI,
GYEONGGI-DO, 16677, KOREA

Model : SM-A135M/DS, SM-A135M

FCC ID : A3LSMA135M

EUT Description : GSM/WCDMA/LTE Phone + BT/BLE and DTS/UNII a/b/g/n/ac

Test Standard(s) : FCC 47 CFR PART 15 SUBPART E

Date Of Issue:

2022-02-21

Prepared by:

UL Korea, Ltd.

26th floor, 152, Teheran-ro, Gangnam-gu Seoul, 06236, Korea

Suwon Test Site: UL Korea, Ltd. Suwon Laboratory

218 Maeyeong-ro, Yeongtong-gu,
Suwon-si, Gyeonggi-do, 16675, Korea
TEL: (031) 337-9902
FAX: (031) 213-5433



Testing Laboratory

TL-637

Revision History

<u>Rev.</u>	<u>Issue Date</u>	<u>Revisions</u>	<u>Revised By</u>
V1	2022-02-08	Initial issue	Sungeun Lee
V2	2022-02-16	Updated to address TCB's question	Sungeun Lee
V3	2022-02-21	Updated to address TCB's question	Sungeun Lee

TABLE OF CONTENTS

1. ATTESTATION OF TEST RESULTS	5
1.1. INTRODUCTION OF TEST DATA REUSE.....	6
1.2. DIFFERENCE.....	6
1.3. SPOT CHECK VERIFICATION DATA SUMMARY	6
1.4. REFERENCE DETAIL	6
2. TEST METHODOLOGY	7
3. FACILITIES AND ACCREDITATION	7
4. CALIBRATION AND UNCERTAINTY	7
4.1. MEASURING INSTRUMENT CALIBRATION	7
4.2. SAMPLE CALCULATION	7
4.3. MEASUREMENT UNCERTAINTY.....	8
4.4. DECISION RULE.....	8
5. EQUIPMENT UNDER TEST	9
5.1. DESCRIPTION OF EUT	9
5.2. DESCRIPTION OF AVAILABLE ANTENNAS	10
5.3. List of test reduction and modes covering other modes:	10
5.4. WORST-CASE CONFIGURATION AND MODE.....	11
5.5. DESCRIPTION OF TEST SETUP.....	13
6. TEST AND MEASUREMENT EQUIPMENT	15
7. SUMMARY TABLE	16
8. MEASUREMENT METHODS	17
9. REFERENCE MEASUREMENTS RESULTS	18
9.1. ON TIME AND DUTY CYCLE RESULTS.....	18
9.2. DUTY CYCLE PLOTS	18
9.3. 26 dB BANDWIDTH.....	19
9.3.1. 802.11a.....	20
9.3.2. 802.11n HT20.....	20
9.3.3. 802.11n HT40.....	20
9.3.4. 802.11ac VHT80.....	21
9.3.5. STRADDLE CHANNEL.....	21
10. ANTENNA PORT TEST RESULTS	22

10.1.	6 dB BANDWIDTH	22
10.1.1.	UNII-3 & 4 BAND	23
10.2.	OUTPUT POWER AND PPSD	24
10.2.1.	802.11a MODE	26
10.2.2.	802.11n HT20 MODE	27
10.2.3.	802.11n HT40 MODE	28
10.2.4.	802.11ac VHT80 MODE	29
10.2.5.	STRADDLE CHANNEL.....	30
10.2.6.	OUTPUT POWER AND PPSD PLOTS (WORST CASE).....	31
11.	TRANSMITTER ABOVE 1 GHz.....	36
11.1.	TX ABOVE 1GHz 1Tx MODE IN THE 5.2GHz BAND.....	39
11.2.	TX ABOVE 1GHz 1Tx MODE IN THE 5.3GHz BAND.....	43
11.3.	TX ABOVE 1GHz 1Tx MODE IN THE 5.5 GHz BAND.....	47
11.4.	TX ABOVE 1GHz 1Tx MODE IN THE 5.8 GHz BAND.....	51
12.	WORST-CASE BELOW 1 GHz	55
13.	AC POWER LINE CONDUCTED EMISSIONS.....	56
14.	DYNAMIC FREQUENCY SELECTION.....	59
14.1.	OVERVIEW.....	59
14.1.1.	LIMITS.....	59
14.1.2.	TEST AND MEASUREMENT SYSTEM.....	62
14.1.3.	SETUP OF EUT.....	65
14.1.4.	DESCRIPTION OF EUT	66
14.2.	RESULTS FOR 80 MHz BANDWIDTH (UNII-2A BAND).....	67
14.2.1.	TEST CHANNEL	67
14.2.2.	RADAR WAVEFORM AND TRAFFIC.....	67
14.2.3.	OVERLAPPING CHANNEL TESTS.....	68
14.2.4.	MOVE AND CLOSING TIME	68
14.3.	RESULTS FOR 80 MHz BANDWIDTH (UNII-2C BAND).....	71
14.3.1.	TEST CHANNEL	71
14.3.2.	RADAR WAVEFORM AND TRAFFIC.....	71
14.3.3.	OVERLAPPING CHANNEL TESTS.....	72
14.3.4.	MOVE AND CLOSING TIME	72
15.	SPOT-CHECK TEST RESULT	75

1. ATTESTATION OF TEST RESULTS

COMPANY NAME: SAMSUNG ELECTRONICS CO., LTD.
EUT DESCRIPTION: GSM/WCDMA/LTE Phone + BT/BLE and DTS/UNII a/b/g/n/ac
MODEL NUMBER: SM-A135M/DS, SM-A135M
SERIAL NUMBER: R38RA00PTXK, R38RA00PTBK (CONDUCTED, Original);
R38RA00PTNW, R38RB01SVER (RADIATED, Original);
R38RB00DXFZ, R38RB00DVEE (RADIATED, Spot-check);
DATE TESTED: 2021-12-23 ~ 2022-01-21(Original);
2022-01-13 ~ 2022-01-27(Spot-Check);

APPLICABLE STANDARDS	
STANDARD	TEST RESULTS
CFR 47 Part 15 Subpart E	Complies

UL Korea, Ltd. tested the above equipment in accordance with the requirements set forth in the above standards. All indications of Pass/Fail in this report are opinions expressed by UL Korea, Ltd. based on interpretations and/or observations of test results. Measurement Uncertainties were not taken into account and are published for informational purposes only. The test results show that the equipment tested is capable of demonstrating compliance with the requirements as documented in this report.

Note: The results documented in this report apply only to the tested sample, under the conditions and modes of operation as described herein. This document may not be altered or revised in any way unless done so by UL Korea, Ltd. and all revisions are duly noted in the revisions section. Any alteration of this document not carried out by UL Korea, Ltd. will constitute fraud and shall nullify the document. This report must not be used by the client to claim product certification, approval, or endorsement by IAS, any agency of the Federal Government, or any agency of any government.

Approved & Released For
UL Korea, Ltd. By:



Seokhwan Hong
Suwon Lab Engineer
UL Korea, Ltd.

Tested By:



Sungeun Lee
Suwon Lab Engineer
UL Korea, Ltd.

1.1. INTRODUCTION OF TEST DATA REUSE

This report referenced from the FCC ID: A3LSMA135M NII WLAN(FCC CFR 47 Part 15E). And the applicant takes full responsibility that the test data as referenced in this report represent compliance for this FCC ID.

1.2. DIFFERENCE

The FCC ID: A3LSMA135M shares the same enclosure and circuit board as FCC ID: A3LSMA135FDSN. The WLAN antennas and surrounding circuitry and layout are identical between these two units.

After confirming through preliminary radiated emissions that the performance of the FCC ID: A3LSMA135FDSN remains representative of FCC ID: A3LSMA135M. The test data of FCC ID: A3LSMA135FDSN being submitted for this application to cover WLAN features.

1.3. SPOT CHECK VERIFICATION SUMMARY DATA

(Worst case of the radiated band-edge and radiated spurious emissions)

Band	Test Item	Mode	Frequency	Test Limit	Original model	Spot check model	Deviation	Remark
					SM-A135F/DSN Results	SM-A135M/DS Results		
					FCC ID : A3LSMA135FDSN	FCC ID : A3LSMA135M		
NII WLAN (5GHz)	Band Edge	802.11n HT40 5190	5190 MHz	54.0 dBuV/m	51.85 dBuV/m	51.85 dBuV/m	0.00 dB	
	RSE	802.11a 5180	10360 MHz	68.2 dBuV/m	51.51 dBuV/m	51.72 dBuV/m	0.21 dB	Noise floor
	Band Edge	802.11n HT40 5310	5310 MHz	54.0 dBuV/m	51.89 dBuV/m	51.40 dBuV/m	-0.49 dB	
	RSE	802.11a 5300	10600 MHz	68.2 dBuV/m	50.75 dBuV/m	51.36 dBuV/m	0.61 dB	Noise floor
	Band Edge	802.11ac VHT80 5530	5530 MHz	54.0 dBuV/m	51.96 dBuV/m	51.85 dBuV/m	-0.11 dB	
	RSE	802.11a 5720	17160 MHz	68.2 dBuV/m	57.60 dBuV/m	56.74 dBuV/m	-0.86 dB	Noise floor
	Band Edge	802.11ac VHT80 5775	5775 MHz	-27.0 dBm	-31.70 dBm	-30.61 dBm	1.09 dB	
	RSE	802.11a 5745	17235 MHz	68.2 dBuV/m	57.64 dBuV/m	55.97 dBuV/m	-1.67 dB	Noise floor

Comparison of two models, upper deviation is within 3 dB range and all test results are under FCC Technical Limits. Please refer to the spot-check test result in section 15.

1.4. REFERENCE DETAIL

Reference application that contains the reused reference data in the individual test reports:

Equipment Class	Reference FCC ID (Parent)	Application Type	Reference Test report number	Exhibit Type	Variant Test Report Number	Data Re-used
DTS	A3LSMA135FDSN	Original Grant	4790215260-E3 (802.11b/g/n)	Test Report	4790215265-E3 (802.11b/g/n)	All
			4790215260-E4 Bluetooth LE	Test Report	4790215265-E4 Bluetooth LE	All
DSS	A3LSMA135FDSN	Original Grant	4790215260-E5 (Bluetooth)	Test Report	4790215265-E5 (Bluetooth)	All
NII	A3LSMA135FDSN	Original Grant	4790215260-E6 (802.11a/n/ac)	Test Report	4790215265-E6 (802.11a/n/ac)	All

2. TEST METHODOLOGY

The tests documented in this report were performed in accordance with following methods.

1. FCC CFR 47 Part 2.
2. FCC CFR 47 Part 15.
3. KDB 789033 D02 General UNII Test Procedures New Rules v02r01
4. KDB 905462 D02 UNII DFS Compliance Procedures New Rules v02
5. KDB 905462 D03 UNII Clients Without Radar Detection New Rules v01r02
6. KDB 291071 DR01-44460(Sept 21, 2021)
7. ANSI C63.10-2013.

3. FACILITIES AND ACCREDITATION

The test sites and measurement facilities used to collect data are located at 218 Maeyeong-ro, Yeongtong-gu, Suwon-si, Gyeonggi-do, 16675, Korea. Line conducted emissions are measured only at the 218 address. The following table identifies which facilities were utilized for radiated emission measurements documented in this report. Specific facilities are also identified in the test results sections.

218 Maeyeong-ro	
<input checked="" type="checkbox"/>	Chamber 1
<input checked="" type="checkbox"/>	Chamber 2
<input checked="" type="checkbox"/>	Chamber 3

UL Korea, Ltd. is accredited by IAS, Laboratory Code TL-637. The full scope of accreditation can be viewed at <https://www.iasonline.org/wp-content/uploads/2017/05/TL-637-cert-New.pdf>.

4. CALIBRATION AND UNCERTAINTY

4.1. MEASURING INSTRUMENT CALIBRATION

The measuring equipment utilized to perform the tests documented in this report has been calibrated in accordance with the manufacturer's recommendations, and is traceable to recognized national standards.

4.2. SAMPLE CALCULATION

Where relevant, the following sample calculation is provided:

$$\begin{aligned} \text{Field Strength (dBuV/m)} &= \text{Measured Voltage (dBuV)} + \text{Antenna Factor (dB/m)} + \\ &\text{Cable Loss (dB)} - \text{Preamp Gain (dB)} \\ 36.5 \text{ dBuV} + 18.7 \text{ dB/m} + 0.6 \text{ dB} - 26.9 \text{ dB} &= 28.9 \text{ dBuV/m} \end{aligned}$$

4.3. MEASUREMENT UNCERTAINTY

Where relevant, the following measurement uncertainty levels have been estimated for tests performed on the apparatus:

PARAMETER	UNCERTAINTY
Conducted Disturbance, 0.15 to 30 MHz	3.02 dB
Radiated Disturbance, 30 MHz to 1 GHz	4.05 dB
Radiated Disturbance, 1 GHz to 18 GHz	5.78 dB
Radiated Disturbance, 18 GHz to 40 GHz	5.58 dB

Uncertainty figures are valid to a confidence level of 95%.

4.4. DECISION RULE

Decision rule for statement(s) of conformity is based on Procedure 2, Clause 4.4.3 in IEC Guide 115:2007.

5. EQUIPMENT UNDER TEST

5.1. DESCRIPTION OF EUT

The EUT is a GSM/WCDMA/LTE Phone + BT/BLE, DTS/UNII a/b/g/n/ac and NFC.
 This test report addresses the NII (WLAN) operational mode.

This report covers the Samsung models SM-A135M/DS and SM-A135M.
 These models are identical in hardware except SM-A135M has single SIM tray.
 With some pre-scan, model SM-A135M/DS was set for final test.

WiFi operating mode

Frequency rage	Mode	Ant.
5GHz (5180 MHz ~ 5825 MHz)	802.11a SISO	TX/RX
	802.11n SISO	TX/RX
	802.11ac SISO	TX/RX

MAXIMUM OUTPUT POWER

The transmitter has a maximum total conducted average output power as follows:

Band	Frequency Range [MHz]	Mode	Output Power [dBm]	Output Power [mW]
UNII-1	5180 - 5240	802.11a	12.97	19.82
		802.11n(HT20)	12.85	19.28
	5190 - 5230	802.11n(HT40)	11.36	13.68
	5210	802.11ac(VHT80)	9.68	9.29
UNII-2A	5260 - 5320	802.11a	12.81	19.10
		802.11n(HT20)	12.93	19.63
	5190 - 5230	802.11n(HT40)	11.89	15.45
	5270 - 5310	802.11ac(VHT80)	10.25	10.59
UNII-2C	5500 - 5720	802.11a	12.85	19.28
		802.11n(HT20)	12.84	19.23
	5510 - 5710	802.11n(HT40)	11.68	14.72
	5530 - 5690	802.11ac(VHT80)	10.83	12.11
UNII-3	5745 - 5825	802.11a	12.65	18.41
		802.11n(HT20)	12.78	18.97
	5755 - 5795	802.11n(HT40)	11.75	14.96
	5775	802.11ac(VHT80)	10.71	11.78

5.2. DESCRIPTION OF AVAILABLE ANTENNAS

An intentional radiator antenna shall be designed to ensure that no antenna other than that furnished by the responsible party can be used with the device. The use of a permanently attached antenna or of an antenna that uses a unique coupling to the intentional radiator shall be considered sufficient to comply with the provisions of this section.

**The internal antenna was Permanently attached.
 Therefore this E.U.T Complies with the requirement of §15.203.**

The radio utilizes a internal antenna, with a maximum gain of:

Frequency Band [MHz]	ANT Gain [dBi]
UNII 1 5150 - 5250	-5.24
UNII 2A 5250 - 5350	-4.92
UNII 2C 5470 - 5725	-4.88
UNII 3 5725 - 5850	-5.24

5.3. List of test reduction and modes covering other modes:

The output power on covered modes is equal to or less than one referenced.

Authorized Frequency Band			
Mode	Antenna Stream	Mode	Covered by
802.11a	SISO	802.11a 1TX	
802.11n HT20		802.11n HT20 1TX	
802.11ac VHT20		802.11ac VHT20 1TX	802.11n HT20 1TX
802.11n HT40		802.11n HT40 1TX	
802.11ac VHT40		802.11ac VHT40 1TX	802.11n HT40 1TX
802.11ac VHT80		802.11ac VHT80 1TX	

Note. The target power is the same, and there is no difference in 11ac(VHT20,40) mode and 11n(HT20,40) spot-check data. Test data was reported in 11n(HT20, 40) modes.

Test case configuration for 802.11a, 802.11n HT20 & 40, 802.11ac VHT20 & 40 & 80 modes :

Mode	Band	SISO Target[dBm]		
		802.11a	802.11n	802.11ac
5GHz (20 MHz)	UNII-1	12	12	12
	UNII-2A	12	12	12
	UNII-2C	12	12	12
	UNII-3	12	12	12
5GHz (40 MHz)	UNII-1		11	11
	UNII-2A		11	11
	UNII-2C		11	11
	UNII-3		11	11
5GHz (80 MHz)	UNII-1			10
	UNII-2A			10
	UNII-2C			10
	UNII-3			10

Note. Compared to the 802.11a mode, target power is the same or lower and the density is low, so only the spot-check test was performed in the 802.11n & 802.11ac mode. Spot check test was performed in the worst tested band of 802.11a mode.

5.5. DESCRIPTION OF TEST SETUP

SUPPORT EQUIPMENT

Support Equipment List				
Description	Manufacturer	Model	Serial Number	FCC ID
Charger	SAMSUNG	EP-TA800	R37N9Q14289RT3	N/A
Data Cable	SAMSUNG	EP-DN980BWE (GH39-02115A, C to C)	N/A	N/A

I/O CABLE

I/O Cable List						
Cable No.	Port	# of identical ports	Connector Type	Cable Type	Cable Length (m)	Remarks
1	DC Power	1	C Type	Shielded	1.0 m	N/A

TEST SETUP

The EUT is a stand-alone unit during the tests.
 Test software exercised the EUT to enable NII mode.

SETUP DIAGRAM FOR TESTS (CONDUCTED TEST SETUP)

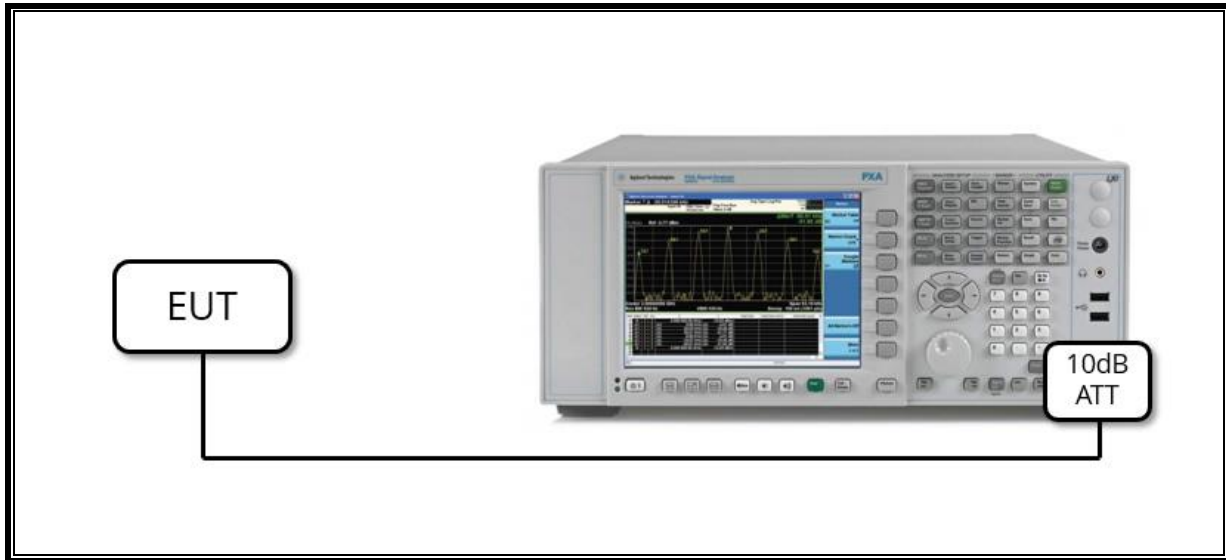

SETUP DIAGRAM FOR TESTS (RADIATED TEST SETUP)

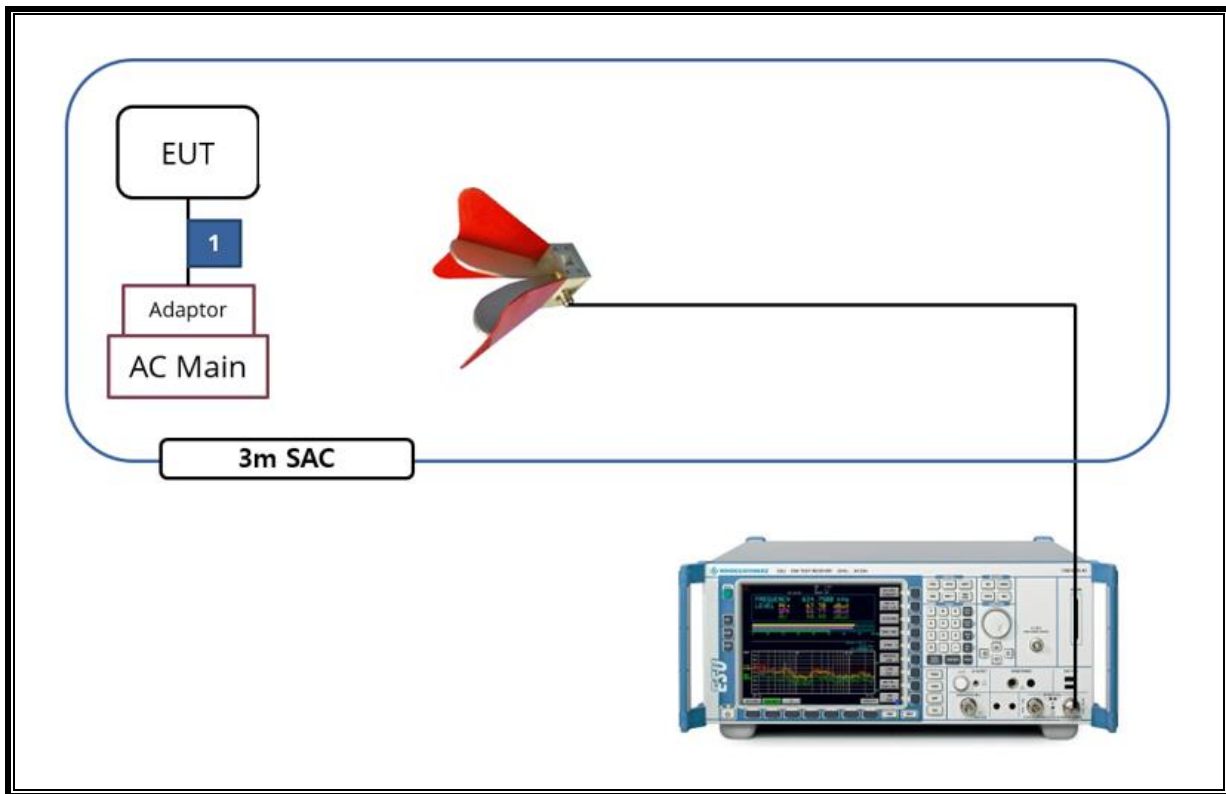

6. TEST AND MEASUREMENT EQUIPMENT

The following test and measurement equipment was utilized for the tests documented in this report:

Test Equipment List				
Description	Manufacturer	Model	S/N	Cal Due
Antenna, Bilog, 30MHz-1GHz	SCHWARZBECK	VULB9163	750	2022-08-19
Antenna, Bilog, 30MHz-1GHz	SCHWARZBECK	VULB9163	749	2022-08-13
Antenna, Bilog, 30MHz-1GHz	SCHWARZBECK	VULB9163	845	2022-08-13
Antenna, Horn, 18 GHz	ETS	3115	00167211	2022-07-27
Antenna, Horn, 18 GHz	ETS	3115	00161451	2022-08-15
Antenna, Horn, 18 GHz	ETS	3117	00168724	2022-07-27
Antenna, Horn, 18 GHz	ETS	3117	00168717	2022-08-15
Antenna, Horn, 18 GHz	ETS	3117	00218957	2023-01-15
Antenna, Horn, 40 GHz	ETS	3116C	00166155	2023-01-15
Antenna, Horn, 40 GHz	ETS	3116C	00168645	2023-10-13
Preamplifier	ETS	3116C-PA	00168841	2022-08-04
Preamplifier, 1000 MHz	Sonoma	310N	341282	2022-08-02
Preamplifier, 1000 MHz	Sonoma	310N	351741	2022-08-02
Preamplifier, 1000 MHz	Sonoma	310N	370599	2022-08-02
Preamplifier, 18 GHz	Miteq	AFS42-00101800-25-S-42	1876511	2022-08-02
Preamplifier, 18 GHz	Miteq	AFS42-00101800-25-S-42	1896138	2022-08-02
Preamplifier, 18 GHz	Miteq	AFS42-00101800-25-S-42	2029168	2022-08-02
Spectrum Analyzer, 44 GHz	Agilent / HP	N9030A	MY54170614	2022-08-04
Spectrum Analyzer, 44 GHz	Agilent / HP	N9030A	MY54490312	2022-08-04
Average Power Sensor	Agilent / HP	U2000	MY54270007	2022-08-04
Average Power Sensor	Agilent / HP	U2000	MY54260010	2022-08-04
Attenuator	PASTERNAK	PE7087-10	A001	2022-08-03
Attenuator	PASTERNAK	PE7087-10	A008	2022-08-03
Attenuator	PASTERNAK	PE7004-10	2	2022-08-02
Attenuator	PASTERNAK	PE7087-10	A009	2022-08-03
EMI Test Receive, 40 GHz	R&S	ESU40	100439	2022-08-02
EMI Test Receive, 40 GHz	R&S	ESU40	100457	2022-08-02
EMI Test Receive, 3 GHz	R&S	ESR3	101832	2022-08-02
Notch Filter	Micro-Tronics	BRM50702-02	G037	2022-08-03
Notch Filter	Micro-Tronics	BRM50716-2	006	2022-08-02
Low Pass Filter 5GHz	Micro-Tronics	LPS17541	009	2022-08-02
Low Pass Filter 5GHz	Micro-Tronics	LPS17541	015	2022-08-02
Low Pass Filter 5GHz	Micro-Tronics	LPS17541	019	2022-08-02
High Pass Filter 3GHz	Micro-Tronics	HPM17543	010	2022-08-02
High Pass Filter 3GHz	Micro-Tronics	HPM17543	015	2022-08-02
High Pass Filter 3GHz	Micro-Tronics	HPM17543	020	2022-08-02
High Pass Filter 6GHz	Micro-Tronics	HPS17542	009	2022-08-02
High Pass Filter 6GHz	Micro-Tronics	HPS17542	016	2022-08-02
High Pass Filter 6GHz	Micro-Tronics	HPS17542	020	2022-08-02
LISN	R&S	ENV-216	101837	2022-08-05
Antenna, Loop, 9kHz-30MHz	R&S	HFH2-Z2	100418	2023-10-06
Termination	WEINSCHHEL	M1406A	T09	2022-08-03
Attenuator	WEINSCHHEL	WA76-30-21	A015	2022-08-03
UL Software				
Description	Manufacturer	Model	Version	
Radiated software	UL	UL EMC	Ver 9.5	
AC Line Conducted software	UL	UL EMC	Ver 9.5	

7. SUMMARY TABLE

FCC Part Section	Test Description	Test Limit	Test Condition	Test Result
15.407(e)	6dB Band width (5.8GHz)	> 500kHz	Conducted	Complies
15.407 (a)(1)(iv)	TX Cond. Power (5.150-5.250)	< 24dBm		Complies
15.407 (a)(2)	TX Cond. Power (5.250-5.350 & 5.470-5.725)	< 24dBm or 11+10Log(26dB BW)		Complies
15.407 (a)(3)(i)	TX Cond. Power (5.725-5.850)	< 30dBm		Complies
15.407 (a)(1)(iv) & (a)(2)	PSD (5.150-5.250 5.250-5.350 & 5.470-5.725)	< 11dBm/MHz		Complies
15.407 (a)(3)	PSD (5.725-5.850)	< 30dBm/500kHz		Complies
15.207 (a)	AC Power Line conducted emissions	Section 13	Radiated	Complies
15.407 (b) & 15.209	Radiated Spurious Emission	< 74dBuV/m PK < 54dBuV/m AV		Complies
15.407 (h)(2)	Dynamic Frequency Selection	N/A	Condcuted	Complies ^{Note}

Note. This EUT does not support channel puncturing.

8. MEASUREMENT METHODS

On-Time and Duty Cycle : KDB 789033 D02 v02r01, Section II.B.

6dB Emission BW : KDB 789033 D02 v02r01, Section II.C.2.

26dB Emission BW : KDB 789033 D02 v02r01, Section II.C.1.

99% Occupied BW : KDB 789033 D02 v02r01, Section II.D.

Conducted Output Power : KDB 789033 D02 v02r01, Section II.E.3.b(Method PM-G)

Conducted Output Power for Straddle Channel (ch144/142/138 for 20/40/80MHz BW):

KDB 789033 D02 v02r01, Section II.E.2.b(Method SA-1)

Power Spectral Density : KDB 789033 D02 v02r01, Section II.F.

Unwanted emissions in restricted bands : KDB 789033 D02 v02r01, Section II.G.3 – II.G.6.

Unwanted emissions in non-restricted bands : KDB 789033 D02 v02r01, Section II.G.3 – II.G.6.

AC Power Line Conducted Emission : ANSI C63.10-2013, Section 6.2.

9. REFERENCE MEASUREMENTS RESULTS

9.1. ON TIME AND DUTY CYCLE RESULTS

Mode	On Time [ms]	Period [ms]	Duty Cycle X [Linear]	Duty Cycle X [%]	Duty Cycle Correction Factor[dB]
802.11a	3.127	3.215	0.973	97.263	0.12
802.11n(HT20)	2.908	3.013	0.965	96.515	0.15
802.11n(HT40)	2.483	2.589	0.959	95.906	0.18
802.11ac(VHT80)	1.968	2.083	0.945	94.479	0.25

Note. If the duty cycle is over 98%, compensation is not included in average measurement.

LIMITS

None; for reporting purposes only.

PROCEDURE

KDB 789033 D02 v02r01 Zero-Span Spectrum Analyzer Method.

9.2. DUTY CYCLE PLOTS



9.3. 26 dB BANDWIDTH

LIMITS

None; for reporting purposes only.

TEST PROCEDURE

Reference to 789033 D02 General UNII Test Procedures New Rules v02r01: The transmitter output is connected to a spectrum analyzer with the RBW set to approximately 1% of EBW, the VBW > RBW, peak detector and max hold.

RESULTS

- Please refer to the next page

WORST CASE TEST PLOTS

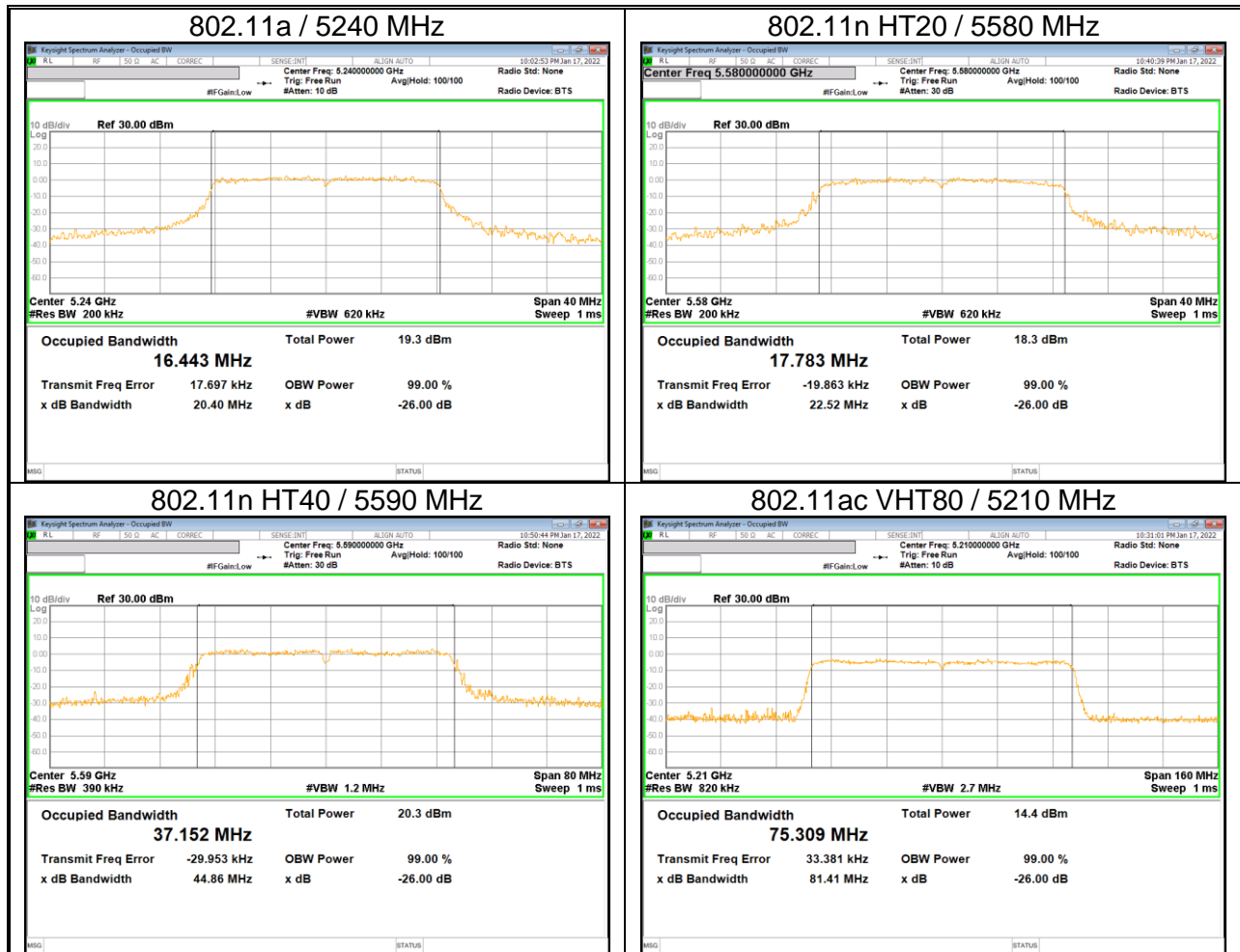

9.3.1. 802.11a

Band	Channel	Center Freq. [MHz]	26 dB BW [MHz]	Worst	99% BW [MHz]
UNII-1 <small>Note</small>	36	5180	20.070	20.400	16.485
	40	5200	20.320		16.447
	48	5240	20.400		16.443
UNII-2A <small>Note</small>	52	5260	20.280	20.280	16.462
	60	5300	19.960		16.491
	64	5320	19.980		16.489
UNII-2C	100	5500	20.380	20.380	
	116	5580	20.270		
	140	5700	19.930		

Note. As a result of 99% bandwidth test, the bandwidth of UNII-1 does not interfere with UNII-2A.

9.3.2. 802.11n HT20

Band	Channel	Center Freq. [MHz]	26 dB BW [MHz]	Worst	99% BW [MHz]
UNII-1 <small>Note</small>	36	5180	21.860	22.240	17.683
	40	5200	22.240		17.634
	48	5240	21.340		17.699
UNII-2A <small>Note</small>	52	5260	21.820	22.160	17.628
	60	5300	22.110		17.669
	64	5320	22.260		17.829
UNII-2C	100	5500	21.010	22.520	
	116	5580	22.520		
	140	5700	21.020		

Note. As a result of 99% bandwidth test, the bandwidth of UNII-1 does not interfere with UNII-2A.

9.3.3. 802.11n HT40

Band	Channel	Center Freq. [MHz]	26 dB BW [MHz]	Worst	99% BW [MHz]
UNII-1 <small>Note</small>	38	5190	41.970	43.210	36.770
	46	5230	43.210		37.338
UNII-2A <small>Note</small>	54	5270	43.180	43.180	37.541
	62	5310	42.150		36.709
UNII-2C	102	5510	42.000	44.860	
	118	5590	44.860		
	134	5670	41.690		

Note. As a result of 99% bandwidth test, the bandwidth of UNII-1 does not interfere with UNII-2A.

9.3.4. 802.11ac VHT80

Band	Channel	Center Freq. [MHz]	26 dB BW [MHz]	Worst	99% BW [MHz]
UNII-1 ^{Note}	42	5210	81.410	81.410	75.309
UNII-2A ^{Note}	58	5290	81.310	81.310	75.111
UNII-2C	106	5530	81.140	81.140	
	122	5610	80.750		

Note. As a result of 99% bandwidth test, the bandwidth of UNII-1 does not interfere with UNII-2A.

9.3.5. STRADDLE CHANNEL

Mode	Channel	Center Freq. [MHz]	26 dB BW [MHz]	
			UNII-2C	UNII-3
802.11a	Straddle	5720	15.524	5.528
802.11n HT20	Straddle	5720	15.728	7.536
802.11n HT40	Straddle	5710	38.768	17.600
802.11ac VHT80	Straddle	5690	84.224	5.472

10. ANTENNA PORT TEST RESULTS

10.1. 6 dB BANDWIDTH

LIMITS

FCC §15.407

The minimum 6 dB bandwidth shall be at least 500 kHz.

TEST PROCEDURE

Reference to 789033 D02 General UNII Test Procedures New Rules v02r01: The transmitter output is connected to a spectrum analyzer with the RBW set to 100kHz, the VBW $\geq 3 \times$ RBW, peak detector and max hold.

RESULTS

- Please refer to the next page

WORST CASE TEST PLOTS

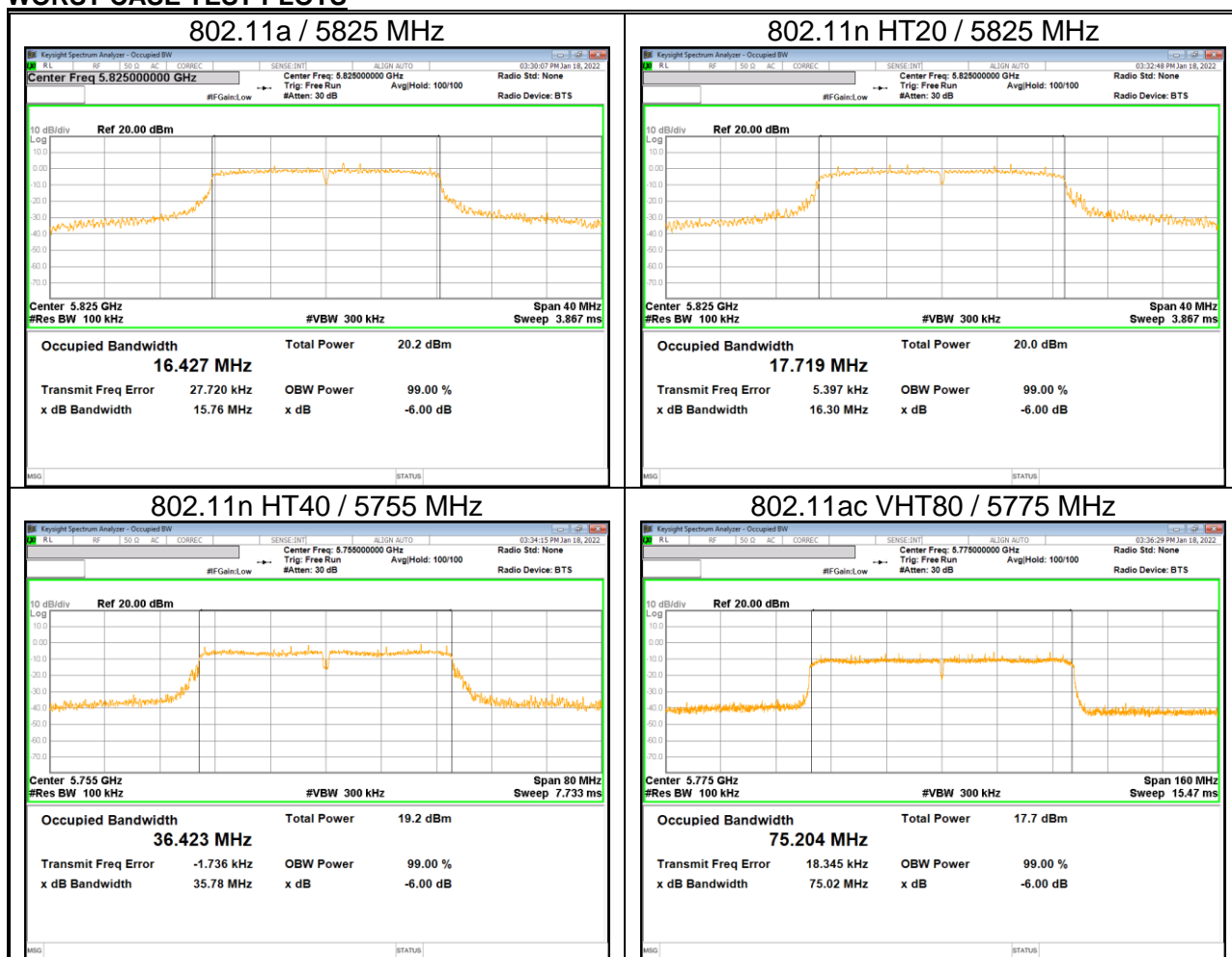

10.1.1. UNII-3 & 4 BAND

Mode	Channel	Center Freq. [MHz]	6 dB BW [MHz]	Worst	Minimum Limit [MHz]
802.11a	149	5745	16.380	15.760	0.5
	157	5785	15.990		
	165	5825	15.760		
802.11n HT20	149	5745	16.320	16.300	
	157	5785	16.510		
	165	5825	16.300		
802.11n HT40	151	5755	35.780	35.780	
	159	5795	36.340		
802.11ac VHT80	155	5775	75.020	75.020	

10.2. OUTPUT POWER AND PPSD

LIMITS

FCC §15.407 (a)(1)(iv), (a)(2), (a)(3)(i), (a)(3)(iii)

FCC

For client devices in the 5.15-5.25 GHz band, the maximum conducted output power over the frequency band of operation shall not exceed 250 mW provided the maximum antenna gain does not exceed 6 dBi. In addition, the maximum power spectral density shall not exceed 11 dBm in any 1 megahertz band. If transmitting antennas of directional gain greater than 6 dBi are used, both the maximum conducted output power and the maximum power spectral density shall be reduced by the amount in dB that the directional gain of the antenna exceeds 6 dBi.

For the 5.25-5.35 GHz and 5.47-5.725 GHz bands, the maximum conducted output power over the frequency bands of operation shall not exceed the lesser of 250 mW or $11 \text{ dBm} + 10 \log B$, where B is the 26 dB emission bandwidth in megahertz. In addition, the maximum power spectral density shall not exceed 11 dBm in any 1 megahertz band. If transmitting antennas of directional gain greater than 6 dBi are used, both the maximum conducted output power and the maximum power spectral density shall be reduced by the amount in dB that the directional gain of the antenna exceeds 6 dBi.

For the band 5.725-5.850 GHz, the maximum conducted output power over the frequency band of operation shall not exceed 1 W. In addition, the maximum power spectral density shall not exceed 30 dBm in any 500-kHz band. If transmitting antennas of directional gain greater than 6 dBi are used, both the maximum conducted output power and the maximum power spectral density shall be reduced by the amount in dB that the directional gain of the antenna exceeds 6 dBi.

TEST PROCEDURE

KDB 789033 Method PM is used for output power.

KDB 789033 Method SA-2 is used for only power of straddle Ch. and PPSD. RBW set to 1MHz(500kHz for the band 5.725-5.85 GHz, the VBW $\geq 3 \times$ RBW, RMS detector and trace averaging). Band power function used for power and peak marker value of the spectrum is used for PSD. For the band 5.850-5.895 GHz, The correlated gain is added to the result to convert e.i.r.p.

DIRECTIONAL ANTENNA GAIN

For OUTPUT POWER and PSD: The TX chains are correlated and the antenna gains are unequal among the chains. The directional gain is:

Frequency Band [MHz]	ANT Gain [dBi]
UNII 1 5150 - 5250	-5.24
UNII 2A 5250 - 5350	-4.92
UNII 2C 5470 - 5725	-4.88
UNII 3 5725 - 5850	-5.24

Note. Since the correlated gain does not exceed 6dBi, bands except for UNII-4 do not consider the antenna gain.

10.2.1. 802.11a MODE

Output Power Results

Band	Channel	Center Freq. [MHz]	Average Power [dBm]	Corr'd Power [dBm]	Limit [dBm]
UNII-1	36	5180	12.64	12.64	23.98
	40	5200	12.75	12.75	
	48	5240	12.97	12.97	
UNII-2A	52	5260	12.80	12.80	23.98
	60	5300	12.81	12.81	
	64	5320	12.53	12.53	
UNII-2C	100	5500	12.56	12.56	23.98
	116	5580	12.85	12.85	
	140	5700	12.03	12.03	
UNII-3	149	5745	12.41	12.41	30.00
	157	5785	12.44	12.44	
	165	5825	12.65	12.65	

* Calculation of Output Power : Average Power = Meas Power + Duty CF[dB]

PSD Results

Band	Channel	Center Freq. [MHz]	Meas PSD [dBm/MHz]	DCCF.	Corr'd PSD [dBm]	Limit [dBm/MHz]
UNII-1	36	5180	0.621	0.12	0.741	11.00
	40	5200	0.456	0.12	0.576	
	48	5240	0.821	0.12	0.941	
UNII-2A	52	5260	0.728	0.12	0.848	11.00
	60	5300	0.861	0.12	0.981	
	64	5320	0.943	0.12	1.063	
UNII-2C	100	5500	0.297	0.12	0.417	11.00
	116	5580	0.896	0.12	1.016	
	140	5700	0.520	0.12	0.640	
UNII-3	149	5745	-2.210	0.12	-2.090	30.00/500kHz
	157	5785	-3.105	0.12	-2.985	
	165	5825	-2.185	0.12	-2.065	

* Calculation of PSD: Corr'd PSD = Meas PSD + Duty CF [dB]

10.2.2. 802.11n HT20 MODE

Output Power Results

Band	Channel	Center Freq. [MHz]	Average Power [dBm]	Corr'd Power [dBm]	Limit [dBm]
UNII-1	36	5180	12.53	12.53	23.98
	40	5200	12.81	12.81	
	48	5240	12.85	12.85	
UNII-2A	52	5260	12.83	12.83	23.98
	60	5300	12.74	12.74	
	64	5320	12.42	12.42	
UNII-2C	100	5500	11.57	11.57	23.98
	116	5580	12.84	12.84	
	140	5700	12.50	12.50	
UNII-3	149	5745	12.51	12.51	30.00
	157	5785	12.33	12.33	
	165	5825	12.78	12.78	

* Calculation of Output Power : Average Power = Meas Power + Duty CF[dB]

PSD Results

Band	Channel	Center Freq. [MHz]	Meas PSD [dBm/MHz]	DCCF.	Corr'd PSD [dBm]	Limit [dBm/MHz]
UNII-1	36	5180	0.716	0.15	0.866	11.00
	40	5200	0.431	0.15	0.581	
	48	5240	1.189	0.15	1.339	
UNII-2A	52	5260	0.633	0.15	0.783	11.00
	60	5300	0.378	0.15	0.528	
	64	5320	0.356	0.15	0.506	
UNII-2C	100	5500	0.480	0.15	0.630	11.00
	116	5580	0.680	0.15	0.830	
	140	5700	0.029	0.15	0.179	
UNII-3	149	5745	-2.844	0.15	-2.694	30.00/500kHz
	157	5785	-3.003	0.15	-2.853	
	165	5825	-3.875	0.15	-3.725	

* Calculation of PSD: Corr'd PSD = Meas PSD + Duty CF [dB]

10.2.3. 802.11n HT40 MODE

Output Power Results

Band	Channel	Center Freq. [MHz]	Average Power [dBm]	Corr'd Power [dBm]	Limit [dBm]
UNII-1	38	5190	10.91	10.91	23.98
	46	5230	11.36	11.36	
UNII-2A	54	5270	11.89	11.89	23.98
	62	5310	11.80	11.80	
UNII-2C	102	5510	11.07	11.07	23.98
	118	5590	11.68	11.68	
	134	5670	11.55	11.55	
UNII-3	151	5755	11.75	11.75	30.00
	159	5795	11.73	11.73	

* Calculation of Output Power : Average Power = Meas Power + Duty CF[dB]

PSD Results

Band	Channel	Center Freq. [MHz]	Meas PSD [dBm/MHz]	DCCF.	Corr'd PSD [dBm]	Limit [dBm/MHz]
UNII-1	38	5190	-4.596	0.18	-4.416	11.00
	46	5230	-4.209	0.18	-4.029	
UNII-2A	54	5270	-4.151	0.18	-3.971	11.00
	62	5310	-5.338	0.18	-5.158	
UNII-2C	102	5510	-4.401	0.18	-4.221	11.00
	118	5590	-3.990	0.18	-3.810	
	134	5670	-4.202	0.18	-4.022	
UNII-3	151	5755	-6.956	0.18	-6.776	30.00/500kHz
	159	5795	-6.478	0.18	-6.298	

* Calculation of PSD: Corr'd PSD = Meas PSD + Duty CF [dB]

10.2.4. 802.11ac VHT80 MODE

Output Power Results

Band	Channel	Center Freq. [MHz]	Average Power [dBm]	Corr'd Power [dBm]	Limit [dBm]
UNII-1	42	5210	9.68	9.68	23.98
UNII-2A	58	5290	10.25	10.25	23.98
UNII-2C	106	5530	10.23	10.23	23.98
	122	5610	10.50	10.50	
UNII-3	155	5775	10.71	10.71	30.00

* Calculation of Output Power : Average Power = Meas Power + Duty CF[dB]

PSD Results

Band	Channel	Center Freq. [MHz]	Meas PSD [dBm/MHz]	DCCF.	Corr'd PSD [dBm]	Limit [dBm/MHz]
UNII-1	42	5210	-9.250	0.25	-9.000	11.00
UNII-2A	58	5290	-7.855	0.25	-7.605	11.00
UNII-2C	106	5530	-7.875	0.25	-7.625	11.00
	122	5610	-8.612	0.25	-8.362	
UNII-3	155	5775	-11.143	0.25	-10.893	30.00/500kHz

* Calculation of PSD: Corr'd PSD = Meas PSD + Duty CF [dB]

10.2.5. STRADDLE CHANNEL

Output Power Results

Mode	Band	Center Freq. [MHz]	Meas Power [dBm]	DCCF.	Corr'd Power [dBm]	Limit [dBm]
802.11a	UNII-2C	5720	11.205	0.12	11.325	22.86
	UNII-3		4.542	0.12	4.662	30.00
802.11n HT20	UNII-2C	5720	10.552	0.15	10.702	23.09
	UNII-3		4.248	0.15	4.398	30.00
802.11n HT40	UNII-2C	5710	9.883	0.18	10.063	23.98
	UNII-3		0.111	0.18	0.291	30.00
802.11ac VHT80	UNII-2C	5690	9.311	0.25	9.561	23.98
	UNII-3		-5.054	0.25	-4.804	30.00

* Calculation of Output Power : Corr'd Power = Meas. Power + Duty CF [dB]

PSD Results

Mode	Band	Center Freq. [MHz]	Meas PSD [dBm/MHz]	DCCF.	Corr'd PSD [dBm]	Limit [dBm/MHz]
802.11a	UNII-2C	5720	0.908	0.12	1.028	11.00
	UNII-3		-1.808	0.12	-1.688	30.00/500kHz
802.11n HT20	UNII-2C	5720	1.008	0.15	1.158	11.00
	UNII-3		-2.646	0.15	-2.496	30.00/500kHz
802.11n HT40	UNII-2C	5710	-3.683	0.18	-3.503	11.00
	UNII-3		-6.712	0.18	-6.532	30.00/500kHz
802.11ac VHT80	UNII-2C	5690	-7.723	0.25	-7.473	11.00
	UNII-3		-11.562	0.25	-11.312	30.00/500kHz

* Calculation of PSD: Corr'd PSD = Meas PSD + Duty CF [dB]

10.2.6. OUTPUT POWER AND PPSD PLOTS (WORST CASE)

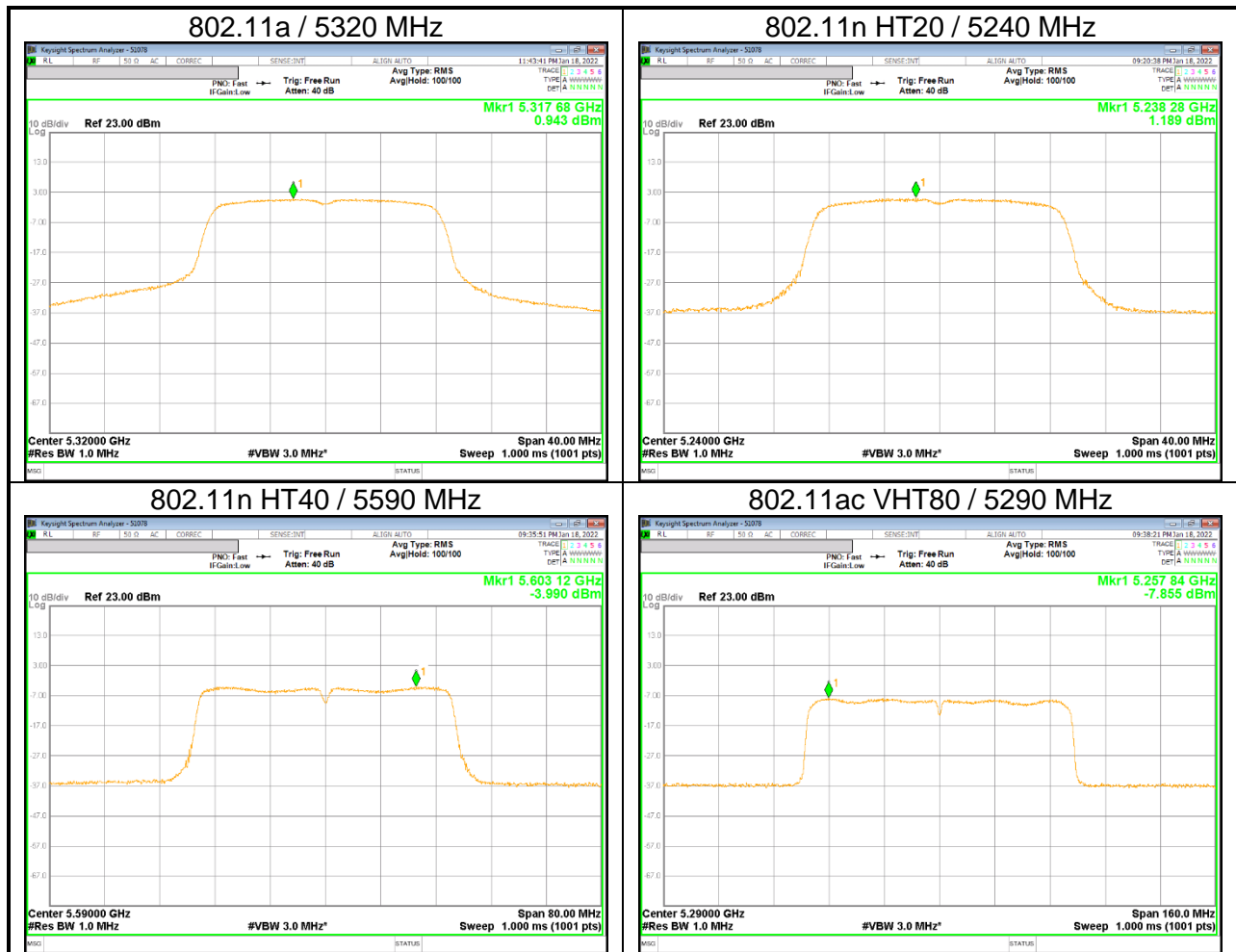

UNII Straddle Ch. IEEE 802.11a mode Output Power and PSD

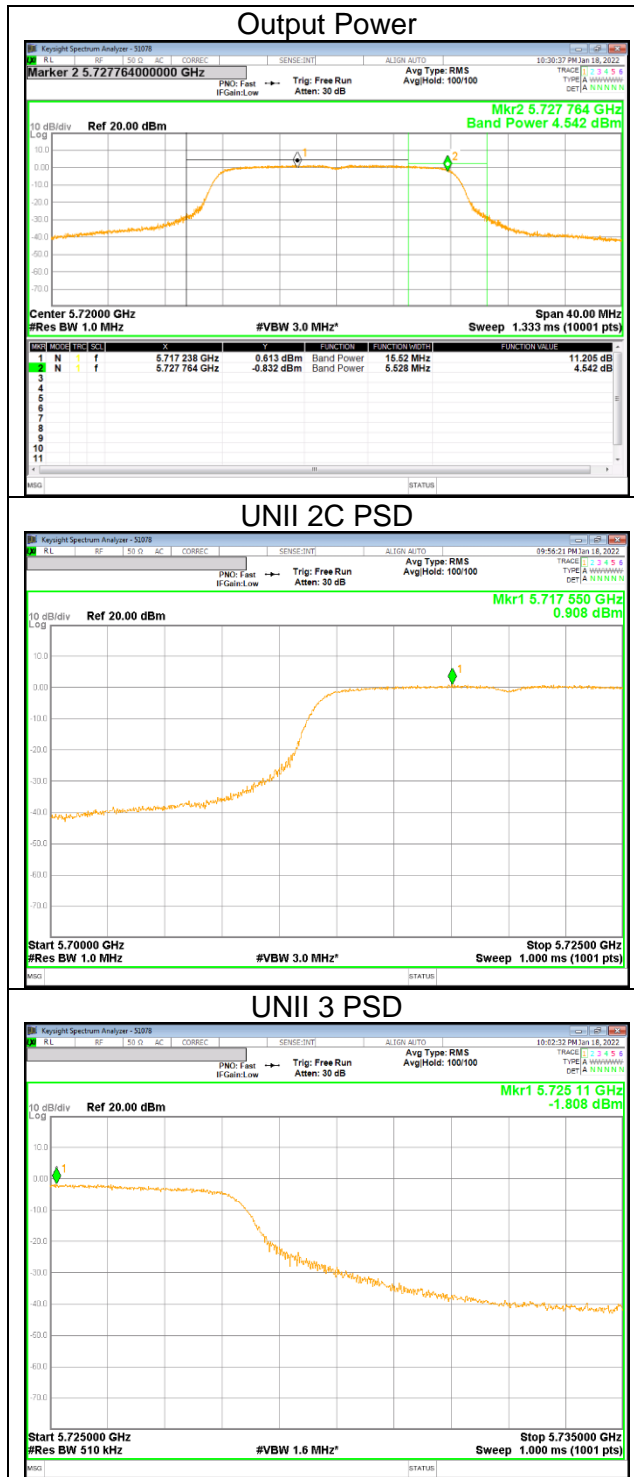

UNII Straddle Ch. IEEE 802.11n HT20 mode Output Power and PSD

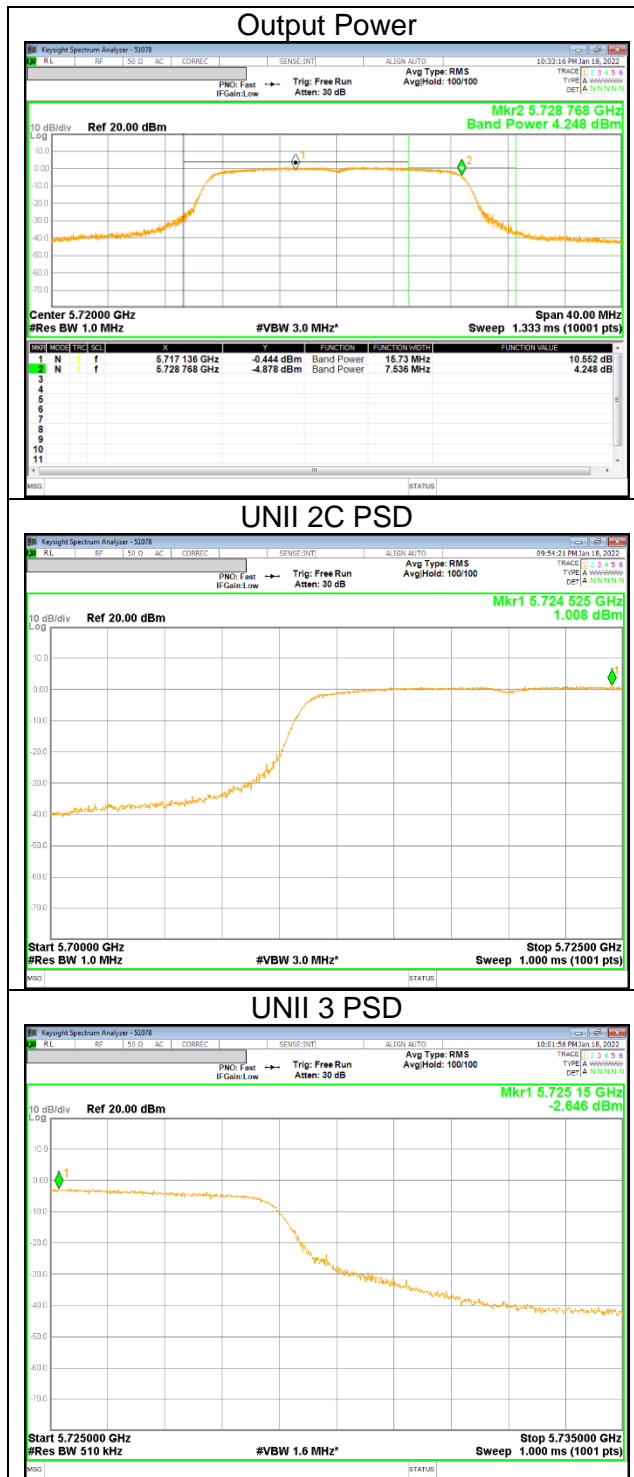

UNII Straddle Ch. IEEE 802.11n HT40 mode Output Power and PSD

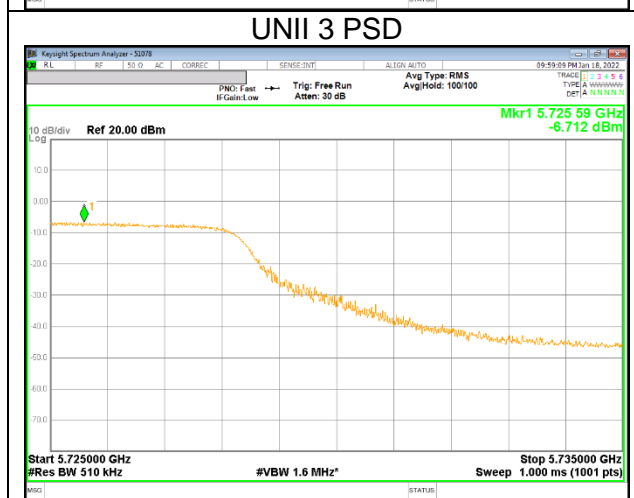
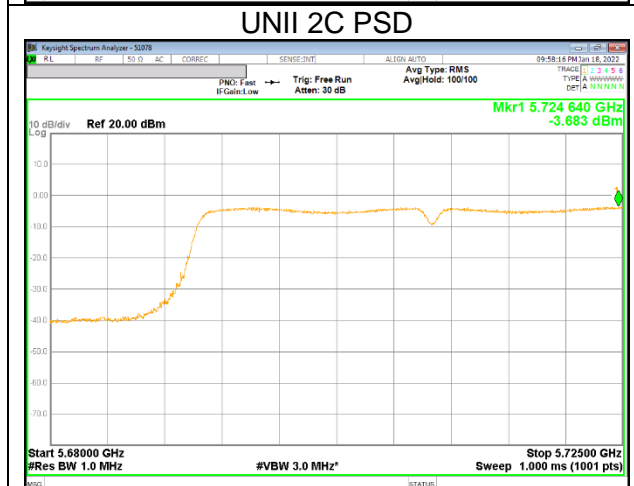
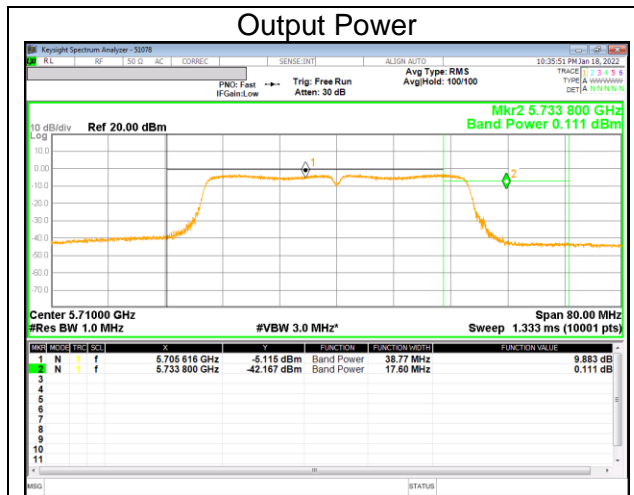

UNII Straddle Ch. IEEE 802.11ac VHT80 mode Output Power and PSD

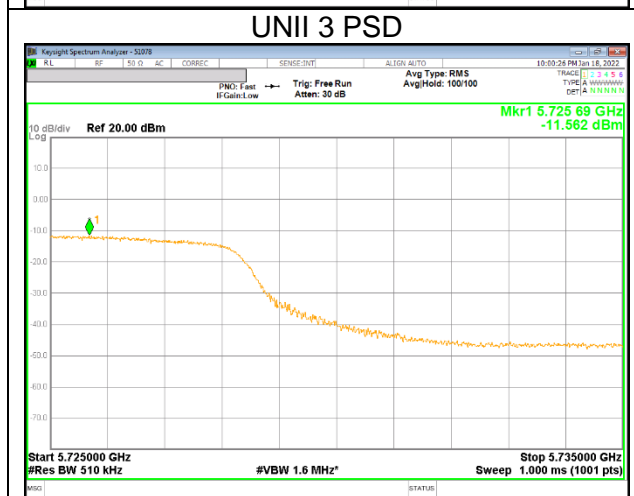
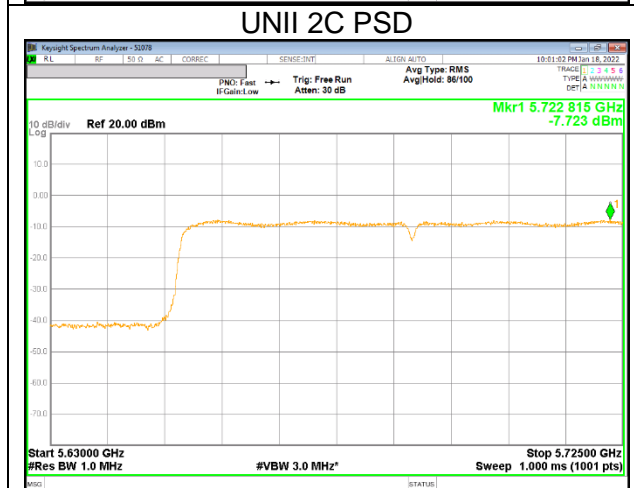
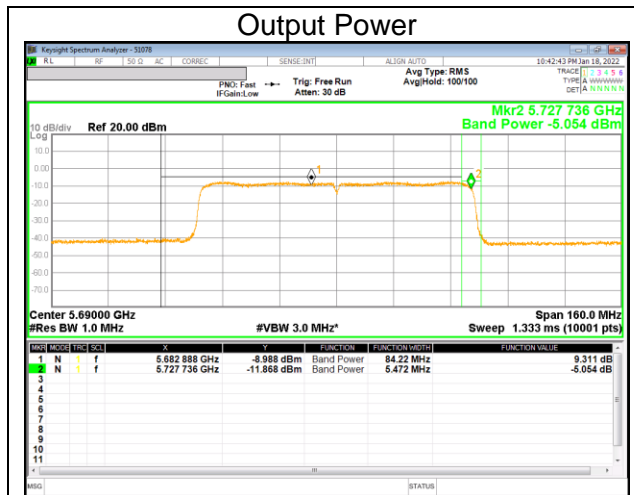

11. TRANSMITTER ABOVE 1 GHz

LIMITS

FCC §15.205 and §15.209

Limits for radiated disturbance of an intentional radiator		
Frequency range (MHz)	Limits (µV/m)	Measurement Distance (m)
0.009 – 0.490	2400 / F (kHz)	300
0.490 – 1.705	24000 / F (kHz)	30
1.705 – 30.0	30	30
30 – 88	100**	3
88 - 216	150**	3
216 – 960	200**	3
Above 960	500	3

** Except as provided in paragraph (g), fundamental emissions from intentional radiators operating under this section shall not be located in the frequency bands 54-72 MHz, 76-88 MHz, 174-216 MHz or 470-806 MHz. However, operation within these frequency bands is permitted under other sections of this part, e.g. §§ 15.231 and 15.241.

FCC Part 15.205 (a) : Only spurious emissions are permitted in any of the frequency bands listed below :

MHz	MHz	MHz	MHz	GHz	GHz
0.009 ~ 0.110	8.41425 ~ 8.41475	108 ~ 121.94	1300 ~ 1427	4.5 ~ 5.15	14.47 ~ 14.5
0.495 ~ 0.505	12.29 ~ 12.293	123 ~ 138	1435 ~ 1626.5	5.35 ~ 5.46	15.35 ~ 16.2
2.1735 ~ 2.1905	12.51975 ~ 12.52025	149.9 ~ 150.05	1645.5 ~ 1646.5	7.25 ~ 7.75	17.7 ~ 21.4
4.125 ~ 4.128	12.57675 ~ 12.57725	156.52475 ~ 156.52525	1660 ~ 1710	8.025 ~ 8.5	22.01 ~ 23.12
4.17725 ~ 4.17775	13.36 ~ 13.41	156.7 ~ 156.9	1718.8 ~ 1722.2	9.0 ~ 9.2	23.6 ~ 24.0
4.20725 ~ 4.20775	16.42 ~ 16.423	162.0125 ~ 167.17	2200 ~ 2300	9.3 ~ 9.5	31.2 ~ 31.8
6.215 ~ 6.218	16.69475 ~ 16.69525	167.72 ~ 173.2	2310 ~ 2390	10.6 ~ 12.7	36.43 ~ 36.5
6.26775 ~ 6.26825	16.80425 ~ 16.80475	240 ~ 285	2483.5 ~ 2500	13.25 ~ 13.4	Above 38.6
6.31175 ~ 6.31225	25.5 ~ 25.67	322 ~ 335.4	2655 ~ 2900		
8.291 ~ 8.294	37.5 ~ 38.25	399.90 ~ 410	3260 ~ 3267		
8.362 ~ 8.366	73 ~ 74.6	608 ~ 614	3332 ~ 3339		
8.37625 ~ 8.38675	74.8 ~ 75.2	960 ~ 1240	3345.8 ~ 3358 3600 ~ 4400		

▪ FCC Part 15.205(b) : The field strength of emissions appearing within these frequency bands shall not exceed the limits shown in §15.209. At frequencies equal to or less than 1000 MHz, compliance with the limits in §15.209 shall be demonstrated using measurement instrumentation employing a CISPR quasi-peak detector. Above 1000 MHz, compliance with the emission limits in §15.209 shall be demonstrated based on the average value of the measured emissions. The provisions in §15.35 apply to these measurements.

FCC §15.407 (b)

(b) Undesirable emission limits. Except as shown in paragraph (b)(7) of this section, the maximum emissions outside of the frequency bands of operation shall be attenuated in accordance with the following limits:

- (1) For transmitters operating in the 5.15-5.25 GHz band: All emissions outside of the 5.15-5.35 GHz band shall not exceed an e.i.r.p. of -27 dBm/MHz.
- (2) For transmitters operating in the 5.25-5.35 GHz band: All emissions outside of the 5.15-5.35 GHz band shall not exceed an e.i.r.p. of -27 dBm/MHz.
- (3) For transmitters operating in the 5.47-5.725 GHz band: All emissions outside of the 5.47-5.725 GHz band shall not exceed an e.i.r.p. of -27 dBm/MHz.
 - (iii) For a client device or indoor access point or subordinate device, all emissions below 5.725 GHz shall not exceed an e.i.r.p. of -27 dBm/MHz at 5.65 GHz increasing linearly to 10 dBm/MHz at 5.7 GHz, and from 5.7 GHz increasing linearly to a level of 15.6 dBm/MHz at 5.72 GHz, and from 5.72 GHz increasing linearly to a level of 27 dBm/MHz at 5.725 GHz
- (5) The emission measurements shall be performed using a minimum resolution bandwidth of 1 MHz. A lower resolution bandwidth may be employed near the band edge, when necessary, provided the measured energy is integrated to show the total power over 1 MHz.
- (6) Unwanted emissions below 1 GHz must comply with the general field strength limits set forth in §15.209. Further, any U-NII devices using an AC power line are required to comply also with the conducted limits set forth in §15.207.
- (7) The provisions of §15.205 apply to intentional radiators operating under this section.
- (8) When measuring the emission limits, the nominal carrier frequency shall be adjusted as close to the upper and lower frequency band edges as the design of the equipment permits.

Note

- Limit translation to field strength level (FCC §15.407)

$$E[\text{dBuV/m}] = \text{EIRP}[\text{dBm}] + 95.2 = -27\text{dBm} + 95.2 = 68.2\text{dBuV/m}$$

$$E[\text{dBuV/m}] = \text{EIRP}[\text{dBm}] + 95.2 = -17\text{dBm} + 95.2 = 78.2\text{dBuV/m}$$

TEST PROCEDURE

The EUT is placed on a non-conducting table 80 cm above the ground plane for below 1GHz and 100 cm for above 1GHz. The antenna to EUT distance is 3 meters. The EUT is configured in accordance with ANSI C63.10. The EUT is set to transmit in a continuous mode.

For measurements below 1 GHz the resolution bandwidth is set to 100 kHz for peak detection measurements or 120 kHz for quasi-peak detection measurements. Peak detection is used unless otherwise noted as quasi-peak.

Reference to KDB 789033 D02 v02r01 UNII part G) 6) c) Method AD:

For measurements above 1 GHz the resolution bandwidth is set to 1 MHz; the video bandwidth is set to 3 MHz for peak measurements and add duty cycle factor to the reading offset for average measurements. In UNII-4, unwanted emissions outside of restricted bands are measured with an RMS detector.

Pre-scans to detect harmonic and spurious emissions, the resolution bandwidth is set to 1 MHz; the video bandwidth is set to 30 kHz for peak measurements.

The spectrum from 1GHz to 40 GHz is investigated with the transmitter set to the lowest, middle, and highest channels in each applicable band.
(From 30MHz to 1GHz, test was performed with the EUT set to transmit at the channel with highest output power)

The frequency range of interest is monitored at a fixed antenna height and EUT azimuth. The EUT is rotated through 360 degrees to maximize emissions received. The antenna is scanned from 1 to 4 meters above the ground plane to further maximize the emission. Measurements are made with the antenna polarized in both the vertical and the horizontal positions.

Note : Emission was pre-scanned from 9kHz to 30MHz; No emissions were detected which was at least 20dB below the specification limit (consider distance correction factor).
Per FCC part 15.31(o), test results were not reported.

Although these tests were performed other than open field test site, adequate comparison measurements were confirmed against 30 m open area test site.
Therefore sufficient tests were made to demonstrate that the alternative site produces results that correlate with the one of tests made in an open field based on KDB 414788.

11.1. TX ABOVE 1GHz 1Tx MODE IN THE 5.2GHz BAND

BANDEDGE (WORST CASE: 802.11n HT40 / 5190 MHz)

HORIZONTAL PEAK AND AVERAGE DATA

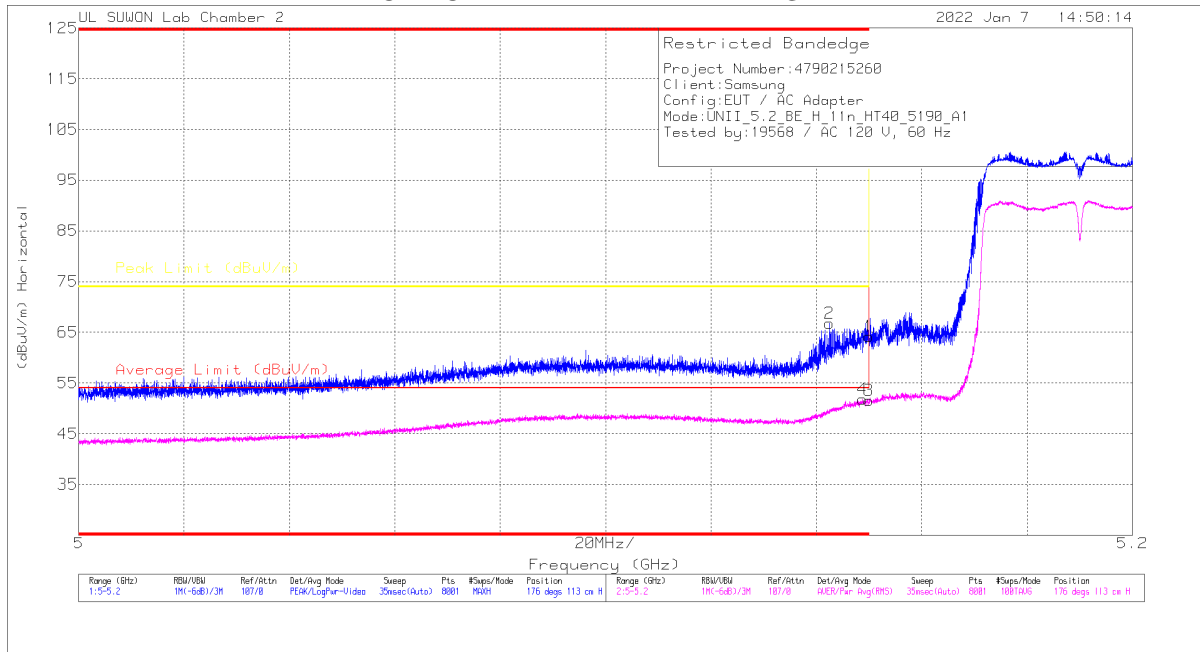

Trace Markers

Marker	Frequency (GHz)	Meter Reading (dBuV)	Det	3117_00168724	10dB_ATT[dB]	DC Corr (dB)	Corrected Reading (dBuV/m)	Average Limit (dBuV/m)	Margin (dB)	Peak Limit (dBuV/m)	PK Margin (dB)	Acimath (Degs)	Height (cm)	Polarity
1	* 5.15	47.73	Pk	34.4	-18	0	64.13	-	-	74	-9.87	176	113	H
2	* 5.14253	50.41	Pk	34.4	-18	0	66.81	-	-	74	-7.19	176	113	H
3	* 5.15	35.03	RMS	34.4	-18	.18	51.61	54	-2.39	-	-	176	113	H
4	* 5.14878	35.27	RMS	34.4	-18	.18	51.85	54	-2.15	-	-	176	113	H

* - indicates frequency in CFR47 Pt 15 / IC RSS-Restricted Band
 PK - Peak detector
 RMS - RMS detection

BANDEDGE TEST DATA

Mode	Freq. [MHz]	Antenna	Frequency [GHz]	Reading [dBuV]	Detector Mode	ANT Factor	Loss [dB]	DC Corr [dB]	Result [dBuV/m]	AV Limit [dBuV/m]	AV Margin [dB]	PK Limit [dBuV/m]	PK Margin [dB]	Azimuth [Degs]	Height [cm]	Polarity
802.11a	5180	ANT1	* 5.15	43.08	Pk	34.40	-18.00	0.00	59.48	-	-	74.00	-14.52	179	100	H
			* 5.14918	46.46	Pk	34.40	-18.00	0.00	62.86	-	-	74.00	-11.14	179	100	H
			* 5.15	33.12	RMS	34.40	-18.00	0.12	49.64	54.00	-4.36	-	-	179	100	H
			* 5.1498	33.62	RMS	34.40	-18.00	0.12	50.14	54.00	-3.86	-	-	179	100	H
			* 5.15	39.20	Pk	34.40	-18.00	0.00	56.60	-	-	74.00	-18.40	151	100	V
			* 5.14893	41.48	Pk	34.40	-18.00	0.00	57.88	-	-	74.00	-16.12	151	100	V
802.11n (HT20)	5180	ANT1	* 5.15	28.81	RMS	34.40	-18.00	0.12	45.33	54.00	-8.67	-	-	151	100	V
			* 5.1496	29.33	RMS	34.40	-18.00	0.12	45.85	54.00	-8.15	-	-	151	100	V
			* 5.15	45.74	Pk	34.40	-18.00	0.00	62.14	-	-	74.00	-11.86	179	100	H
			* 5.14648	50.23	Pk	34.40	-18.10	0.00	66.53	-	-	74.00	-7.47	179	100	H
			* 5.15	33.65	RMS	34.40	-18.00	0.15	50.20	54.00	-3.80	-	-	179	100	H
			* 5.14995	33.87	RMS	34.40	-18.00	0.15	50.42	54.00	-3.58	-	-	179	100	H
802.11n (HT40)	5190	ANT1	* 5.15	40.76	Pk	34.40	-18.00	0.00	57.16	-	-	74.00	-16.84	136	100	V
			* 5.14975	43.83	Pk	34.40	-18.00	0.00	60.23	-	-	74.00	-13.77	136	100	V
			* 5.15	29.80	RMS	34.40	-18.00	0.15	46.35	54.00	-7.65	-	-	136	100	V
			* 5.1493	30.05	RMS	34.40	-18.00	0.15	46.60	54.00	-7.40	-	-	136	100	V
			* 5.15	47.73	Pk	34.40	-18.00	0.00	64.13	-	-	74.00	-9.87	176	113	H
			* 5.14253	50.41	Pk	34.40	-18.00	0.00	66.81	-	-	74.00	-7.19	176	113	H
802.11ac (VHT80)	5210	ANT1	* 5.15	35.03	RMS	34.40	-18.00	0.18	51.61	54.00	-2.39	-	-	176	113	H
			* 5.14878	35.27	RMS	34.40	-18.00	0.18	51.85	54.00	-2.15	-	-	176	113	H
			* 5.15	42.01	Pk	34.40	-18.00	0.00	58.41	-	-	74.00	-15.59	151	100	V
			* 5.14923	44.24	Pk	34.40	-18.00	0.00	60.64	-	-	74.00	-13.36	151	100	V
			* 5.15	29.98	RMS	34.40	-18.00	0.18	46.56	54.00	-7.44	-	-	151	100	V
			* 5.14865	30.61	RMS	34.40	-18.00	0.18	47.19	54.00	-6.81	-	-	151	100	V

Note1. Pk - Peak detector, RMS - RMS detector

Note2. * - indicates frequency in CFR47 Pt 15 / IC RSS-Restricted Band

HARMONICS AND SPURIOUS EMISSIONS(WORST CASE: 802.11a / 5180 MHz)
5180 MHz HORIZONTAL

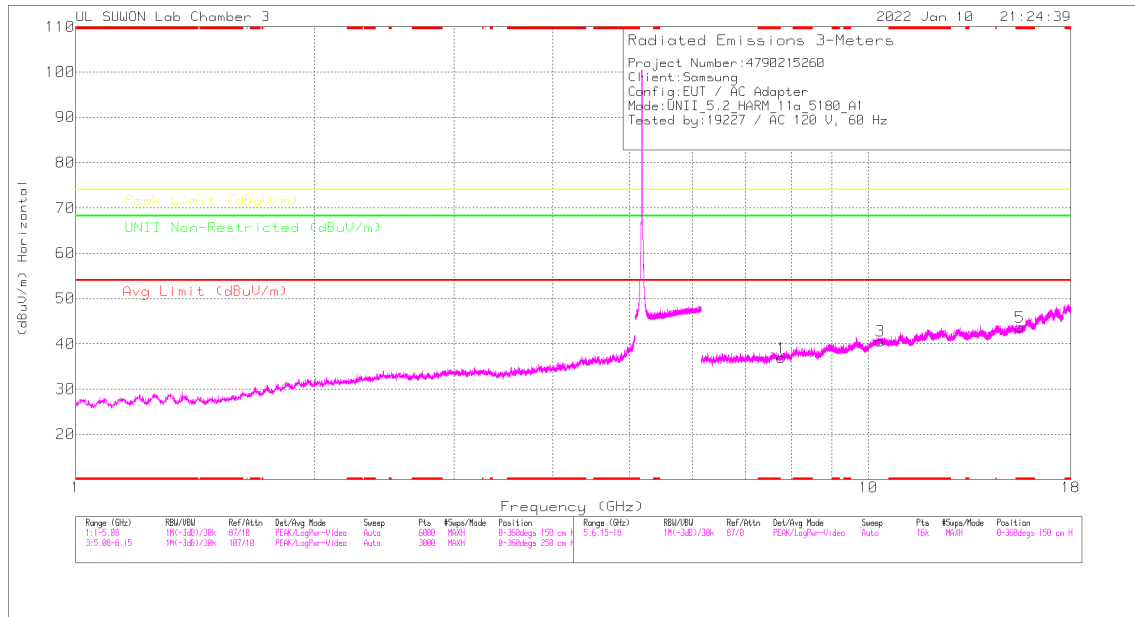

5180 MHz VERTICAL

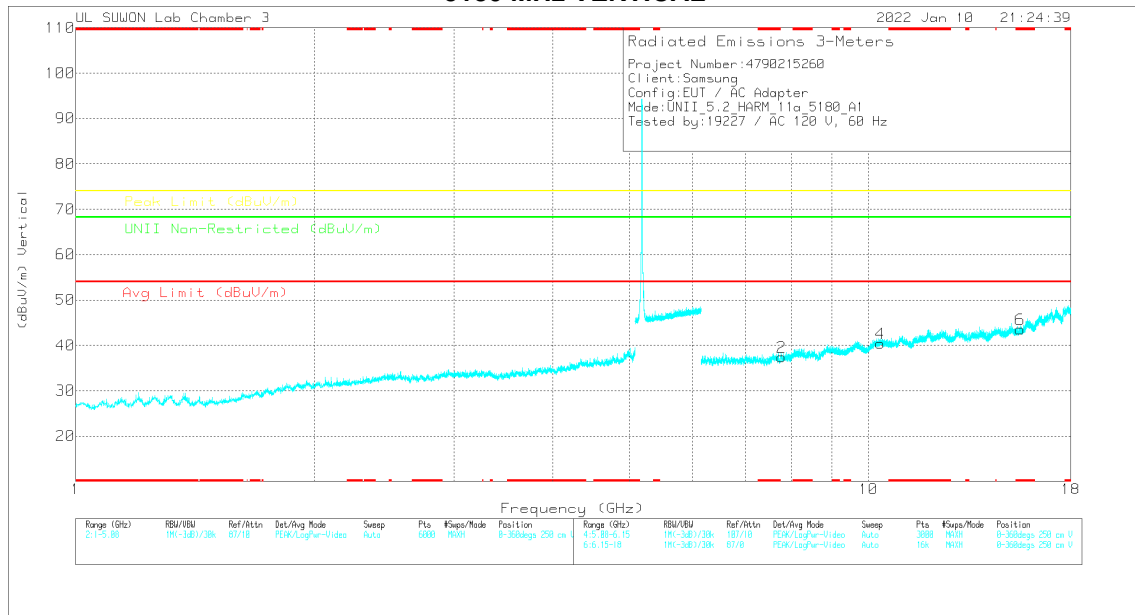

Note: Emission was scanned up to 40GHz; No emissions were detected above the noise floor which was at least 20dB below the specification limit.

Radiated Emissions

Frequency (GHz)	User Reading (dBuV/m)	Det	317_00218967	6GHz_HPSB	DC Corr (dB)	Corrected Reading (dBuV/m)	Avg Limit (dBuV/m)	Margin (dB)	Peak Limit (dBuV/m)	Margin (dB)	UNII Non-Restricted (dBuV/m)	Margin (dB)	Altitude (ft/m)	Height (cm)	Polarity
7.77173	36.38	PK-U	36.3	-25	0	47.68	-	-	-	-	68.2	-20.52	360	100	H
7.76334	36.37	PK-U	36.3	-25	0	47.67	-	-	-	-	68.2	-20.53	360	100	V
10.35742	34.28	PK-U	38.1	-21.4	0	50.98	-	-	-	-	68.2	-17.22	360	100	H
10.35636	34.71	PK-U	38.1	-21.3	0	51.51	-	-	-	-	68.2	-16.69	360	100	V
* 15.54814	35.06	PK-U	40.2	-21.9	0	53.36	-	-	74	-20.64	-	-	360	100	H
* 15.53143	34.83	PK-U	40.2	-22	0	53.03	-	-	74	-20.97	-	-	360	100	V

* - indicates frequency in CFR47 Pt 15 / IC RSS-Restricted Band
 PK-U - U-NII: Maximum Peak

HARMONICS AND SPURIOUS EMISSIONS TEST DATA

Mode	Freq. [MHz]	Antenna	Frequency [GHz]	Reading [dBuV]	Detector Mode	ANT Factor	Loss [dB]	DC Corr [dB]	Result [dBuV/m]	AV Limit [dBuV/m]	AV Margin [dB]	PK Limit [dBuV/m]	PK Margin [dB]	Non-Restricted [dBuV/m]	Margin [dB]	Azimuth [Degs]	Height [cm]	Polarity		
802.11a	5180	ANT1	7.772	36.38	PK-U	36.30	-25.00	0.00	47.68	-	-	-	-	68.20	-20.52	360	100	H		
			7.763	36.37	PK-U	36.30	-25.00	0.00	47.67	-	-	-	-	68.20	-20.53	360	100	V		
			10.357	34.28	PK-U	38.10	-21.40	0.00	50.98	-	-	-	-	-	68.20	-17.22	360	100	H	
			10.356	34.71	PK-U	38.10	-21.30	0.00	51.51	-	-	-	-	-	68.20	-16.69	360	100	V	
			* 15.54814	35.06	PK-U	40.20	-21.90	0.00	53.36	-	-	74.00	-20.64	-	-	-	-	360	100	H
			* 15.53143	34.83	PK-U	40.20	-22.00	0.00	53.03	-	-	74.00	-20.97	-	-	-	-	360	100	V
	5200	ANT1	7.796	36.00	PK-U	36.30	-24.70	0.00	47.60	-	-	-	-	68.20	-20.60	360	100	H		
			7.792	36.04	PK-U	36.30	-24.80	0.00	47.54	-	-	-	-	68.20	-20.66	360	100	V		
			10.400	34.68	PK-U	38.10	-21.40	0.00	51.38	-	-	-	-	-	68.20	-16.82	360	100	H	
			10.406	34.38	PK-U	38.10	-21.40	0.00	51.08	-	-	-	-	-	68.20	-17.12	360	100	V	
			* 15.60477	34.26	PK-U	40.30	-21.70	0.00	52.86	-	-	74.00	-21.14	-	-	-	-	360	100	H
			* 15.59668	34.78	PK-U	40.30	-21.90	0.00	53.18	-	-	74.00	-20.82	-	-	-	-	360	100	V
	5240	ANT1	7.856	35.48	PK-U	36.30	-24.30	0.00	47.48	-	-	-	-	68.20	-20.72	360	100	H		
			7.857	35.85	PK-U	36.30	-24.30	0.00	47.85	-	-	-	-	68.20	-20.35	360	100	V		
			10.476	34.37	PK-U	38.20	-21.50	0.00	51.07	-	-	-	-	-	68.20	-17.13	360	100	H	
			10.486	33.71	PK-U	38.20	-21.50	0.00	50.41	-	-	-	-	-	68.20	-17.79	360	100	V	
			* 15.72969	34.76	PK-U	40.50	-21.50	0.00	53.76	-	-	74.00	-20.24	-	-	-	-	360	100	H
			* 15.72324	34.61	PK-U	40.50	-21.50	0.00	53.61	-	-	74.00	-20.39	-	-	-	-	360	100	V

Note1. PK-U - U-NII: Maximum Peak

Note2. * - indicates frequency in CFR47 Pt 15 / IC RSS-Restricted Band

11.2. TX ABOVE 1GHz 1Tx MODE IN THE 5.3GHz BAND

BANDEDGE (WORST CASE: 802.11n HT40 / 5310 MHz)

HORIZONTAL PEAK AND AVERAGE DATA

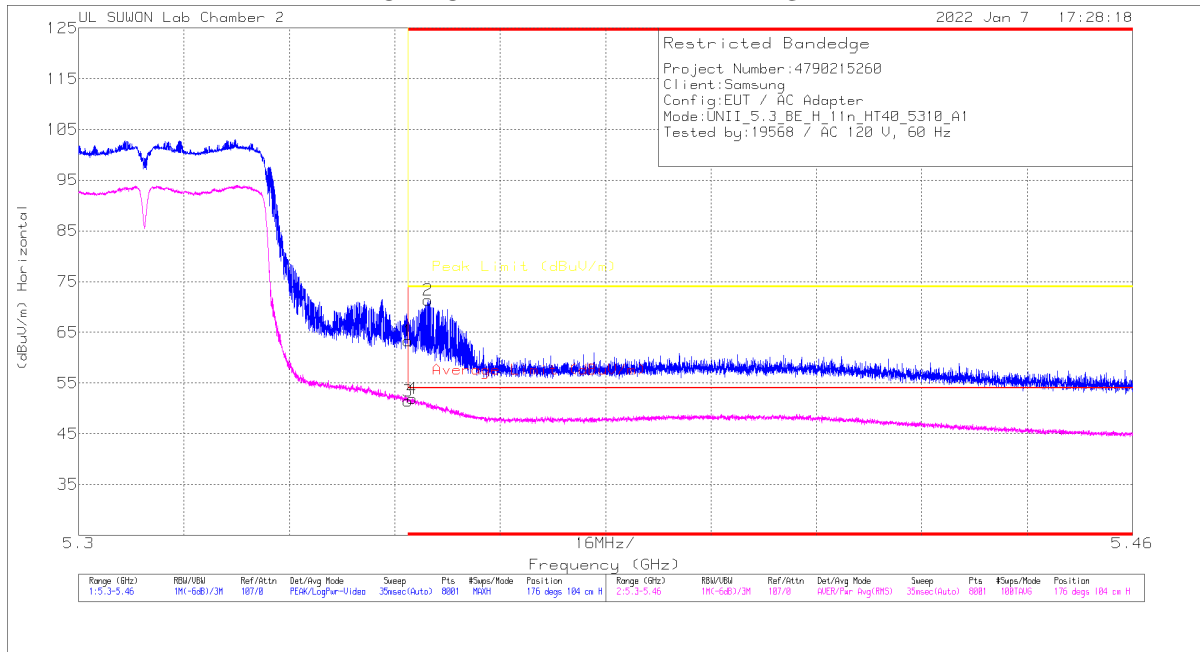

Trace Markers

Marker	Frequency (GHz)	Meter Reading (dBuV)	Det	3117_00168724	10dB_ATT[dB]	DC Corr (dB)	Corrected Reading (dBuV/m)	Average Limit (dBuV/m)	Margin (dB)	Peak Limit (dBuV/m)	PK Margin (dB)	Azimuth (Degs)	Height (cm)	Polarity
1	* 5.35002	46.76	Pk	34.5	-18	0	63.26	-	-	74	-10.74	176	104	H
2	* 5.353	54.89	Pk	34.5	-18	0	71.39	-	-	74	-2.61	176	104	H
3	* 5.35002	34.76	RMS	34.5	-18	-18	51.44	54	-2.56	-	-	176	104	H
4	* 5.35064	35.21	RMS	34.5	-18	-18	51.89	54	-2.11	-	-	176	104	H

* - indicates frequency in CFR47 Pt 15 / IC RSS-Restricted Band
 Pk - Peak detector
 RMS - RMS detection

BANDEDGE TEST DATA

Mode	Freq. [MHz]	Antenna	Frequency [GHz]	Reading [dBuV]	Detector Mode	ANT Factor	Loss [dB]	DC Corr [dB]	Result [dBuV/m]	AV Limit [dBuV/m]	AV Margin [dB]	PK Limit [dBuV/m]	PK Margin [dB]	Azimuth [Degs]	Height [cm]	Polarity	
802.11a	5320	ANT1	* 5.35002	43.67	Pk	34.50	-18.00	0.00	60.17	-	-	74.00	-13.83	176	104	H	
			* 5.35016	45.22	Pk	34.50	-18.00	0.00	61.72	-	-	74.00	-12.28	176	104	H	
			* 5.35002	31.97	RMS	34.50	-18.00	0.12	48.59	54.00	-5.41	-	-	-	176	104	H
			* 5.35052	32.65	RMS	34.50	-18.00	0.12	49.27	54.00	-4.73	-	-	-	176	104	H
			* 5.35002	40.45	Pk	34.50	-18.00	0.00	56.95	-	-	-	74.00	-17.05	137	100	V
			* 5.35094	42.41	Pk	34.50	-18.00	0.00	58.91	-	-	-	74.00	-15.09	137	100	V
			* 5.35002	29.13	RMS	34.50	-18.00	0.12	45.75	54.00	-8.25	-	-	-	137	100	V
			* 5.35116	29.74	RMS	34.50	-18.00	0.12	46.36	54.00	-7.64	-	-	-	137	100	V
			* 5.35002	42.96	Pk	34.50	-18.00	0.00	59.46	-	-	-	74.00	-14.54	174	166	H
			* 5.35004	45.81	Pk	34.50	-18.00	0.00	62.31	-	-	-	74.00	-11.69	174	166	H
802.11n (HT20)	5320	ANT1	* 5.35002	31.98	RMS	34.50	-18.00	0.15	48.63	54.00	-5.37	-	-	174	166	H	
			* 5.35024	32.26	RMS	34.50	-18.00	0.15	48.91	54.00	-5.09	-	-	174	166	H	
			* 5.35002	41.70	Pk	34.50	-18.00	0.00	58.20	-	-	-	74.00	-15.80	136	100	V
			* 5.35278	42.62	Pk	34.50	-18.00	0.00	59.12	-	-	-	74.00	-14.88	136	100	V
			* 5.35002	29.72	RMS	34.50	-18.00	0.15	46.37	54.00	-7.63	-	-	-	136	100	V
			* 5.35096	30.17	RMS	34.50	-18.00	0.15	46.82	54.00	-7.18	-	-	-	136	100	V
			* 5.35002	46.76	Pk	34.50	-18.00	0.00	63.26	-	-	-	74.00	-10.74	176	104	H
			* 5.353	54.89	Pk	34.50	-18.00	0.00	71.39	-	-	-	74.00	-2.61	176	104	H
			* 5.35002	34.76	RMS	34.50	-18.00	0.18	51.44	54.00	-2.56	-	-	-	176	104	H
			* 5.35064	35.21	RMS	34.50	-18.00	0.18	51.89	54.00	-2.11	-	-	-	176	104	H
802.11n (HT40)	5310	ANT1	* 5.35001	41.89	Pk	35.10	-20.70	0.00	56.29	-	-	74.00	-17.71	124	100	V	
			* 5.35173	45.08	Pk	35.10	-20.80	0.00	59.38	-	-	-	74.00	-14.62	124	100	V
			* 5.35001	31.11	RMS	35.10	-20.70	0.18	45.69	54.00	-8.31	-	-	-	124	100	V
			* 5.39829	32.15	RMS	35.20	-20.60	0.18	46.93	54.00	-7.07	-	-	-	124	100	V
			* 5.35002	43.97	Pk	34.50	-18.00	0.00	60.47	-	-	-	74.00	-13.53	176	137	H
			* 5.37312	47.03	Pk	34.50	-18.00	0.00	63.53	-	-	-	74.00	-10.47	176	137	H
			* 5.35002	33.30	RMS	34.50	-18.00	0.25	50.05	54.00	-3.95	-	-	-	176	137	H
			* 5.37638	34.60	RMS	34.50	-18.10	0.25	51.25	54.00	-2.75	-	-	-	176	137	H
			* 5.35002	40.50	Pk	34.50	-18.00	0.00	57.00	-	-	-	74.00	-17.00	161	108	V
			* 5.38366	44.78	Pk	34.50	-18.10	0.00	61.18	-	-	-	74.00	-12.82	161	108	V
802.11ac (VHT80)	5290	ANT1	* 5.35002	30.44	RMS	34.50	-18.00	0.25	47.19	54.00	-6.81	-	-	161	108	V	
			* 5.35666	31.09	RMS	34.50	-18.00	0.25	47.84	54.00	-6.16	-	-	-	161	108	V

Note1. Pk - Peak detector, RMS - RMS detector

Note2. * - indicates frequency in CFR47 Pt 15 / IC RSS-Restricted Band

HARMONICS AND SPURIOUS EMISSIONS(WORST CASE: 802.11n HT20 / 5260 MHz)
5260 MHz HORIZONTAL

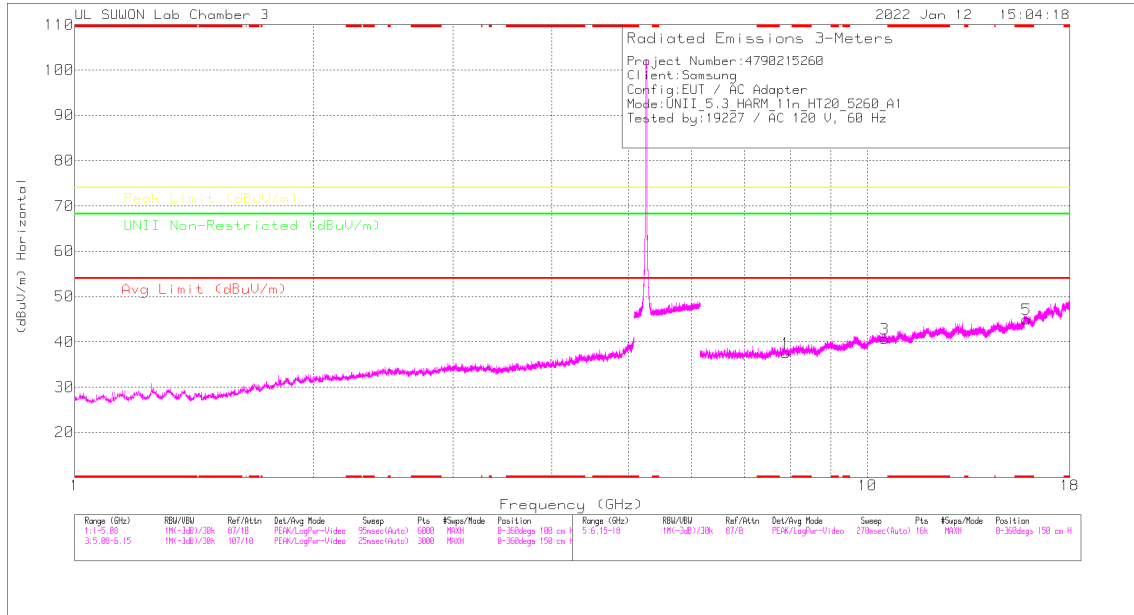

5260 MHz VERTICAL

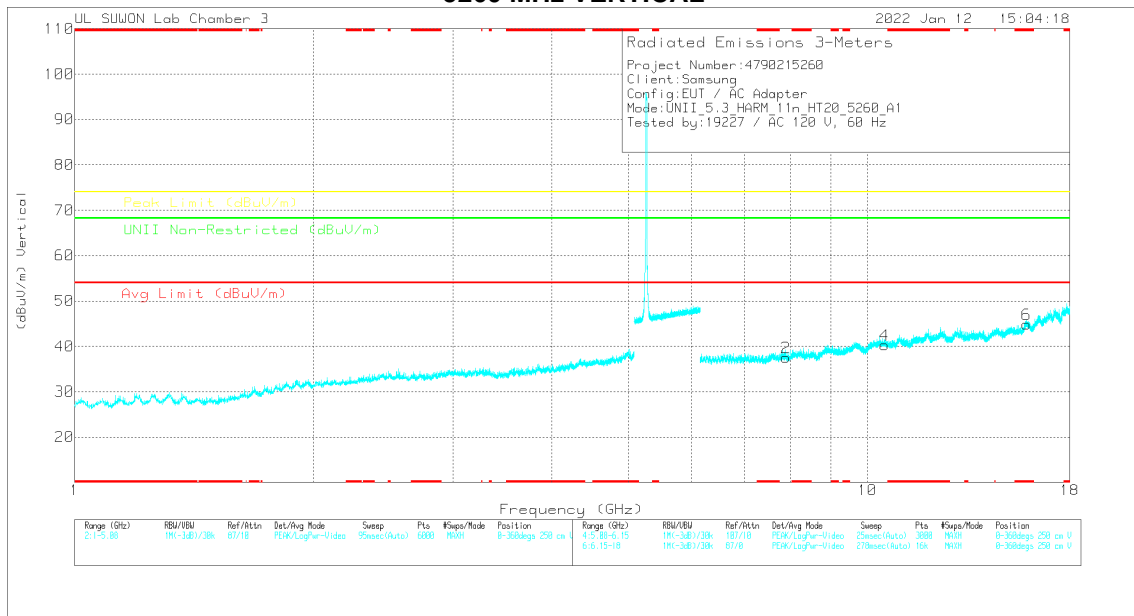

Note: Emission was scanned up to 40GHz; No emissions were detected above the noise floor which was at least 20dB below the specification limit.

Radiated Emissions

Frequency (GHz)	Max. Reading (dBu)	Det.	317_00218567	6GHz_HPS(S)	DC Corr (dB)	Corrected Reading (dBu)	Avg Limit (dBu/m)	Margin (dB)	Peak Limit (dBu/m)	Margin (dB)	UNII Non-Restricted (dBu/m)	Margin (dB)	Azimuth (Deg)	Height (cm)	Polarity
7.88946	36.72	PK-U	36.3	-24.3	0	48.72	-	-	-	-	68.2	-19.48	0	100	H
7.89254	36.34	PK-U	36.3	-24.4	0	48.24	-	-	-	-	68.2	-19.96	0	100	V
10.52912	33.4	PK-U	38.2	-21.4	0	50.2	-	-	-	-	68.2	-18	0	100	H
10.52955	34.26	PK-U	38.2	-21.3	0	51.16	-	-	-	-	68.2	-17.04	0	100	V
* 15.87673	34.47	PK-U	40.8	-20.8	0	54.47	-	-	74	-19.53	-	-	0	100	H
* 15.86091	33.9	PK-U	40.7	-20.8	0	53.8	-	-	74	-20.2	-	-	0	100	V

* - indicates frequency in CFR47 Pt 15 / IC RSS-Restricted Band
 PK-U - U-NII: Maximum Peak

HARMONICS AND SPURIOUS EMISSIONS TEST DATA

Mode	Freq. [MHz]	Antenna	Frequency [GHz]	Reading [dBuV]	Detector Mode	ANT Factor	Loss [dB]	DC Corr [dB]	Result [dBuV/m]	AV Limit [dBuV/m]	AV Margin [dB]	PK Limit [dBuV/m]	PK Margin [dB]	Non-Restricted [dBuV/m]	Margin [dB]	Azimuth [Degs]	Height [cm]	Polarity	
802.11a	5260	ANT1	7.888	36.05	PK-U	36.30	-24.30	0.00	48.05	-	-	-	-	68.20	-20.15	360	100	H	
			10.523	33.68	PK-U	38.20	-21.50	0.00	50.38	-	-	-	-	68.20	-17.82	360	100	H	
			* 15.78987	34.64	PK-U	40.60	-21.30	0.00	53.94	-	-	74.00	-20.06	-	-	360	100	H	
			* 15.78198	34.65	PK-U	40.60	-21.30	0.00	53.95	-	-	74.00	-20.05	-	-	360	100	V	
			7.891	35.95	PK-U	36.30	-24.30	0.00	47.95	-	-	-	-	-	68.20	-20.25	360	100	V
			10.517	33.92	PK-U	38.20	-21.40	0.00	50.72	-	-	-	-	-	68.20	-17.48	360	100	V
	5300	ANT1	7.959	35.80	PK-U	36.30	-24.60	0.00	47.50	-	-	-	-	68.20	-20.70	360	100	H	
			7.947	36.66	PK-U	36.30	-24.60	0.00	48.36	-	-	-	-	68.20	-19.84	360	100	V	
			10.597	33.95	PK-U	38.30	-21.50	0.00	50.75	-	-	-	-	68.20	-17.45	360	100	H	
			10.595	32.90	PK-U	38.30	-21.50	0.00	49.70	-	-	-	-	68.20	-18.50	360	100	V	
			* 15.89115	34.36	PK-U	40.80	-20.90	0.00	54.26	-	-	74.00	-19.74	-	-	360	100	H	
			* 15.90477	34.42	PK-U	40.80	-21.00	0.00	54.22	-	-	74.00	-19.78	-	-	360	100	V	
	5320	ANT1	7.985	36.25	PK-U	36.30	-24.60	0.00	47.95	-	-	-	-	68.20	-20.25	360	100	H	
			7.987	36.05	PK-U	36.30	-24.70	0.00	47.65	-	-	-	-	68.20	-20.55	360	100	V	
			* 10.64479	33.66	PK-U	38.30	-21.50	0.00	50.46	-	-	74.00	-23.54	-	-	360	100	H	
			* 10.63418	33.25	PK-U	38.30	-21.50	0.00	50.05	-	-	74.00	-23.95	-	-	360	100	V	
			* 15.9674	34.33	PK-U	40.90	-20.90	0.00	54.33	-	-	74.00	-19.67	-	-	360	100	H	
			* 15.96525	34.28	PK-U	40.90	-20.90	0.00	54.28	-	-	74.00	-19.72	-	-	360	100	V	
802.11n (HT20) Spot-Check	5260	ANT1	7.889	36.72	PK-U	36.30	-24.30	0.00	48.72	-	-	-	-	68.20	-19.48	0	100	H	
			7.893	36.34	PK-U	36.30	-24.40	0.00	48.24	-	-	-	-	68.20	-19.96	0	100	V	
			10.529	33.40	PK-U	38.20	-21.40	0.00	50.20	-	-	-	-	68.20	-18.00	0	100	H	
			10.530	34.26	PK-U	38.20	-21.30	0.00	51.16	-	-	-	-	68.20	-17.04	0	100	V	
			* 15.87673	34.47	PK-U	40.80	-20.80	0.00	54.47	-	-	74.00	-19.53	-	-	0	100	H	
			* 15.86091	33.90	PK-U	40.70	-20.80	0.00	53.80	-	-	74.00	-20.20	-	-	0	100	V	
802.11n (HT40) Spot-Check	5270	ANT1	7.907	37.09	PK-U	36.30	-24.40	0.00	48.99	-	-	-	-	68.20	-19.21	0	100	H	
			7.906	35.92	PK-U	36.30	-24.40	0.00	47.82	-	-	-	-	68.20	-20.38	0	100	V	
			10.547	33.54	PK-U	38.20	-21.50	0.00	50.24	-	-	-	-	68.20	-17.96	0	100	H	
			10.542	33.60	PK-U	38.20	-21.50	0.00	50.30	-	-	-	-	68.20	-17.90	0	100	V	
			* 15.81281	34.26	PK-U	40.80	-21.20	0.00	53.96	-	-	74.00	-20.34	-	-	0	100	H	
			* 15.81081	34.34	PK-U	40.60	-21.20	0.00	53.74	-	-	74.00	-20.26	-	-	0	100	V	
802.11ac (VHT80) Spot-Check	5290	ANT1	7.939	36.34	PK-U	36.30	-24.50	0.00	48.14	-	-	-	-	68.20	-20.06	0	100	H	
			7.933	36.56	PK-U	36.30	-24.40	0.00	48.46	-	-	-	-	68.20	-19.74	0	100	V	
			10.586	33.09	PK-U	38.30	-21.50	0.00	49.89	-	-	-	-	68.20	-18.51	0	100	H	
			10.579	33.23	PK-U	38.30	-21.50	0.00	50.03	-	-	-	-	68.20	-18.17	0	100	V	
			* 15.8767	34.56	PK-U	40.80	-20.80	0.00	54.56	-	-	74.00	-19.44	-	-	0	100	H	
			* 15.86502	34.90	PK-U	40.70	-20.90	0.00	54.70	-	-	74.00	-19.30	-	-	0	100	V	

Note1. PK-U - U-NII: Maximum Peak / ADR - U-NII AD primary method, RMS average
 Note2. * - indicates frequency in CFR47 Pt 15 / IC RSS-Restricted Band

11.3. TX ABOVE 1GHz 1Tx MODE IN THE 5.5 GHz BAND

BANDEDGE (WORST CASE: 802.11ac VHT80 / 5530 MHz)

HORIZONTAL PEAK AND AVERAGE DATA

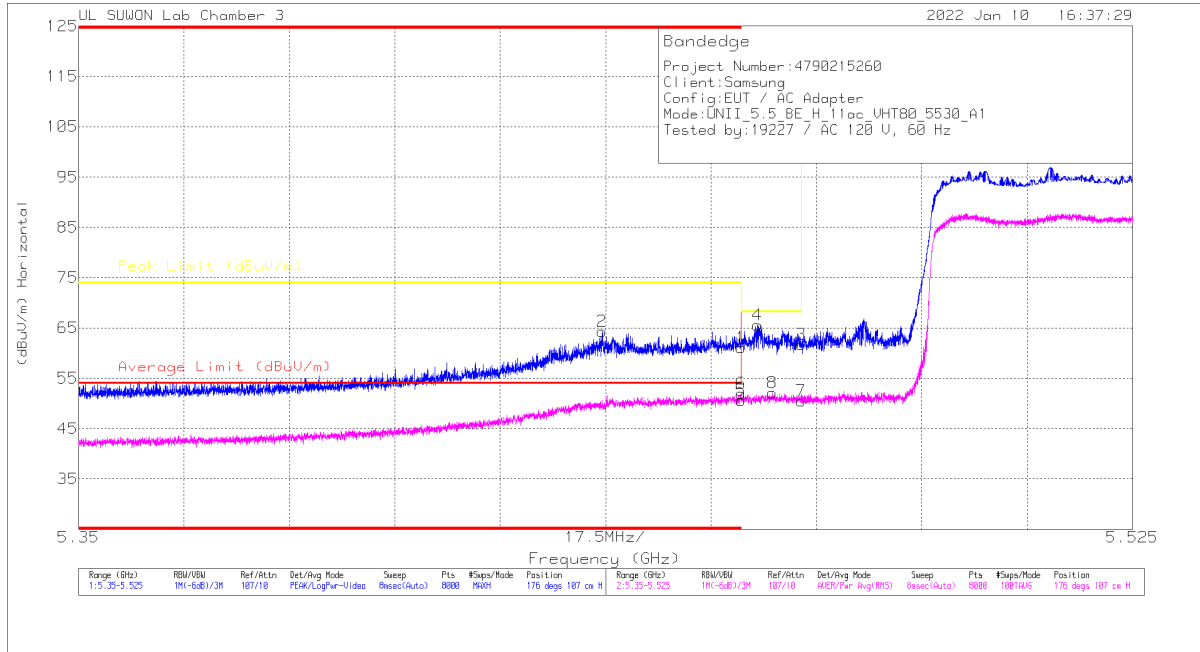

Trace Markers

Marker	Frequency (GHz)	Meter Reading (dBuV)	Det	3117_00218957	10dB_ATT[dB]	DC Corr (dB)	Corrected Reading (dBuV/m)	Average Limit (dBuV/m)	Margin (dB)	Peak Limit (dBuV/m)	PK Margin (dB)	Azimuth (Degs)	Height (cm)	Polarity
1	* 5.45998	46.43	Pk		-20.6	0	61.13	-	-	74	-12.87	176	107	H
2	* 5.45994	49.73	Pk		-20.7	0	64.33	-	-	74	-9.67	176	107	H
3	5.46998	46.98	Pk		-20.6	0	61.68	-	-	68.2	-6.52	176	107	H
4	5.46276	50.86	Pk		-20.6	0	65.56	-	-	68.2	-2.64	176	107	H
5	* 5.45998	35.65	RMS		-20.6	25	50.6	54	-3.4	-	-	176	107	H
6	* 5.45996	37.01	RMS		-20.6	25	51.96	54	-2.04	-	-	176	107	H
7	5.46998	35.5	RMS		-20.6	25	50.45	-	-	-	-	176	107	H
8	5.46525	37.2	RMS		-20.6	25	52.15	-	-	-	-	176	107	H

* - indicates frequency in CFR47 Pt 15 / IC RSS-Restricted Band
 Pk - Peak detector
 RMS - RMS detection

BANDEDGE TEST DATA

Mode	Freq. [MHz]	Antenna	Frequency [GHz]	Reading [dBuV]	Detector Mode	ANT Factor	Loss [dB]	DC Corr [dB]	Result [dBuV/m]	AV Limit [dBuV/m]	AV Margin [dB]	PK Limit [dBuV/m]	PK Margin [dB]	Azimuth [Degs]	Height [cm]	Polarity	
802.11a	5500	ANT1	* 5.45999	40.62	Pk	34.60	-18.00	0.00	57.22	-	-	74.00	-16.78	177	107	H	
			* 5.45911	42.60	Pk	34.60	-18.10	0.00	59.10	-	-	74.00	-14.90	177	107	H	
			5.46998	44.99	Pk	34.60	-18.00	0.00	61.59	-	-	68.20	-6.61	177	107	H	
			5.46854	47.76	Pk	34.60	-18.00	0.00	64.36	-	-	68.20	-3.84	177	107	H	
			* 5.45999	31.15	RMS	34.60	-18.00	0.12	47.87	54.00	-6.13	-	-	-	177	107	H
			* 5.45994	31.45	RMS	34.60	-18.00	0.12	48.17	54.00	-5.83	-	-	-	177	107	H
			5.46998	34.04	RMS	34.60	-18.00	0.12	50.76	-	-	-	-	-	177	107	H
			5.46918	34.31	RMS	34.60	-18.00	0.12	51.03	-	-	-	-	-	177	107	H
			* 5.45999	38.79	Pk	34.60	-18.00	0.00	55.39	-	-	74.00	-18.61	144	134	V	
			* 5.45314	40.91	Pk	34.60	-18.10	0.00	57.41	-	-	74.00	-16.59	144	134	V	
	5.46998	39.84	Pk	34.60	-18.00	0.00	56.44	-	-	68.20	-11.76	144	134	V			
	5.46898	42.73	Pk	34.60	-18.00	0.00	59.33	-	-	68.20	-8.87	144	134	V			
	* 5.45999	28.12	RMS	34.60	-18.00	0.12	44.84	54.00	-9.16	-	-	-	144	134	V		
	* 5.45835	28.60	RMS	34.60	-18.10	0.12	45.22	54.00	-8.78	-	-	-	144	134	V		
	5.46998	29.54	RMS	34.60	-18.00	0.12	46.26	-	-	-	-	-	144	134	V		
	5.46893	29.84	RMS	34.60	-18.00	0.12	46.56	-	-	-	-	-	144	134	V		
	5.72502	43.72	Pk	34.70	-17.40	0.00	61.02	-	-	68.20	-7.18	180	100	H			
	5.72541	46.42	Pk	34.70	-17.40	0.00	63.72	-	-	68.20	-4.48	180	100	H			
	5.72502	38.72	Pk	34.70	-17.40	0.00	56.02	-	-	68.20	-12.18	161	106	V			
	5.72544	41.01	Pk	34.70	-17.40	0.00	58.31	-	-	68.20	-9.89	161	106	V			
802.11n (HT20)	5500	ANT1	* 5.45999	40.54	Pk	34.60	-18.00	0.00	57.14	-	-	74.00	-16.86	176	113	H	
			* 5.45918	43.28	Pk	34.60	-18.10	0.00	59.78	-	-	74.00	-14.22	176	113	H	
			5.46998	43.89	Pk	34.60	-18.00	0.00	60.49	-	-	68.20	-7.71	176	113	H	
			5.46874	48.84	Pk	34.60	-18.00	0.00	65.44	-	-	68.20	-2.76	176	113	H	
			* 5.45999	30.75	RMS	34.60	-18.00	0.15	47.50	54.00	-6.50	-	-	-	176	113	H
			* 5.45959	31.03	RMS	34.60	-18.10	0.15	47.68	54.00	-6.32	-	-	-	176	113	H
			5.46998	32.34	RMS	34.60	-18.00	0.15	49.09	-	-	-	-	-	176	113	H
			5.46963	33.25	RMS	34.60	-18.00	0.15	50.00	-	-	-	-	-	176	113	H
			* 5.45999	38.23	Pk	34.60	-18.00	0.00	54.83	-	-	74.00	-19.17	137	113	V	
			* 5.45894	40.46	Pk	34.60	-18.10	0.00	56.96	-	-	74.00	-17.04	137	113	V	
	5.46998	39.13	Pk	34.60	-18.00	0.00	55.73	-	-	68.20	-12.47	137	113	V			
	5.46633	43.71	Pk	34.60	-18.10	0.00	60.21	-	-	68.20	-7.99	137	113	V			
	* 5.45999	28.52	RMS	34.60	-18.00	0.15	45.27	54.00	-8.73	-	-	-	137	113	V		
	* 5.45988	28.75	RMS	34.60	-18.00	0.15	45.50	54.00	-8.50	-	-	-	137	113	V		
	5.46998	29.84	RMS	34.60	-18.00	0.15	46.59	-	-	-	-	-	137	113	V		
	5.46946	30.24	RMS	34.60	-18.00	0.15	46.99	-	-	-	-	-	137	113	V		
	5.72500	47.38	Pk	35.70	-20.00	0.00	63.08	-	-	68.20	-5.12	182	100	H			
	5.72503	49.52	Pk	35.70	-20.00	0.00	65.22	-	-	68.20	-2.98	182	100	H			
	5.72500	41.76	Pk	35.70	-20.00	0.00	57.46	-	-	68.20	-10.74	166	234	V			
	5.72530	43.96	Pk	35.70	-20.00	0.00	59.66	-	-	68.20	-8.54	166	234	V			
802.11n (HT40)	5510	ANT1	* 5.45998	45.22	Pk	35.30	-20.60	0.00	59.92	-	-	74.00	-14.08	183	117	H	
			* 5.45996	47.13	Pk	35.30	-20.60	0.00	61.83	-	-	74.00	-12.17	183	117	H	
			5.46998	49.40	Pk	35.30	-20.60	0.00	64.10	-	-	68.20	-4.10	183	117	H	
			5.46611	50.86	Pk	35.30	-20.60	0.00	65.56	-	-	68.20	-2.64	183	117	H	
			* 5.45998	32.85	RMS	35.30	-20.60	0.18	47.73	54.00	-6.27	-	-	-	183	117	H
			* 5.41102	33.51	RMS	35.20	-20.60	0.18	48.29	54.00	-5.71	-	-	-	183	117	H
			5.46998	35.54	RMS	35.30	-20.60	0.18	50.42	-	-	-	-	-	183	117	H
			5.46932	36.78	RMS	35.30	-20.60	0.18	51.66	-	-	-	-	-	183	117	H
			* 5.45998	41.41	Pk	35.30	-20.60	0.00	56.11	-	-	74.00	-17.89	133	108	V	
			* 5.45976	43.82	Pk	35.30	-20.60	0.00	58.52	-	-	74.00	-15.48	133	108	V	
	5.46998	44.98	Pk	35.30	-20.60	0.00	59.68	-	-	68.20	-8.52	133	108	V			
	5.46129	45.81	Pk	35.30	-20.60	0.00	60.51	-	-	68.20	-7.69	133	108	V			
	* 5.45998	29.42	RMS	35.30	-20.60	0.18	44.30	54.00	-9.70	-	-	-	133	108	V		
	* 5.45943	30.37	RMS	35.30	-20.60	0.18	45.25	54.00	-8.75	-	-	-	133	108	V		
	5.46998	31.13	RMS	35.30	-20.60	0.18	46.01	-	-	-	-	-	133	108	V		
	5.46864	32.45	RMS	35.30	-20.60	0.18	47.33	-	-	-	-	-	133	108	V		
	5.72500	47.03	Pk	35.70	-20.00	0.00	62.73	-	-	68.20	-5.47	186	100	H			
	5.72511	49.05	Pk	35.70	-20.00	0.00	64.75	-	-	68.20	-3.45	186	100	H			
	5.72500	39.45	Pk	35.70	-20.00	0.00	55.15	-	-	68.20	-13.05	163	104	V			
	5.73635	42.26	Pk	35.70	-19.90	0.00	58.06	-	-	68.20	-10.14	163	104	V			
802.11ac (VHT80)	5530	ANT1	* 5.45998	46.43	Pk	35.30	-20.60	0.00	61.13	-	-	74.00	-12.87	176	107	H	
			* 5.43694	49.73	Pk	35.30	-20.70	0.00	64.33	-	-	74.00	-9.67	176	107	H	
			5.46998	46.98	Pk	35.30	-20.60	0.00	61.68	-	-	68.20	-6.52	176	107	H	
			5.46276	50.86	Pk	35.30	-20.60	0.00	65.56	-	-	68.20	-2.64	176	107	H	
			* 5.45998	35.65	RMS	35.30	-20.60	0.25	50.60	54.00	-3.40	-	-	-	176	107	H
			* 5.45996	37.01	RMS	35.30	-20.60	0.25	51.96	54.00	-2.04	-	-	-	176	107	H
			5.46998	35.50	RMS	35.30	-20.60	0.25	50.45	-	-	-	-	-	176	107	H
			5.46525	37.20	RMS	35.30	-20.60	0.25	52.15	-	-	-	-	-	176	107	H
			* 5.45998	42.41	Pk	35.30	-20.60	0.00	57.11	-	-	74.00	-16.89	134	108	V	
			* 5.43683	44.49	Pk	35.30	-20.70	0.00	59.09	-	-	74.00	-14.91	134	108	V	
	5.46998	41.11	Pk	35.30	-20.60	0.00	55.81	-	-	68.20	-12.39	134	108	V			
	5.46280	44.63	Pk	35.30	-20.60	0.00	59.33	-	-	68.20	-8.87	134	108	V			
	* 5.45998	29.92	RMS	35.30	-20.60	0.25	44.87	54.00	-9.13	-	-	-	134	108	V		
	* 5.45631	32.05	RMS	35.30	-20.60	0.25	47.00	54.00	-7.00	-	-	-	134	108	V		
	5.46998	30.46	RMS	35.30	-20.60	0.25	45.41	-	-	-	-	-	134	108	V		
	5.46794	31.66	RMS	35.30	-20.60	0.25	46.61	-	-	-	-	-	134	108	V		
	5.72500	44.35	Pk	35.70	-20.00	0.00	60.05	-	-	68.20	-8.15	184	109	H			
	5.72713	45.20	Pk	35.70	-20.00	0.00	60.90	-	-	68.20	-7.30	184	109	H			
	5.72500	36.34	Pk	35.70	-20.00	0.00	52.04	-	-	68.20	-16.16	157	356	V			
	5.82186	39.41	Pk	35.80	-19.80	0.00	55.41	-	-	68.20	-12.79	157	356	V			

Note1. Pk - Peak detector, RMS - RMS detector
 Note2. * - indicates frequency in CFR47 Pt 15 / IC RSS-Restricted Band

HARMONICS AND SPURIOUS EMISSIONS(WORST CASE: 802.11a / 5720 MHz)
5720 MHz HORIZONTAL

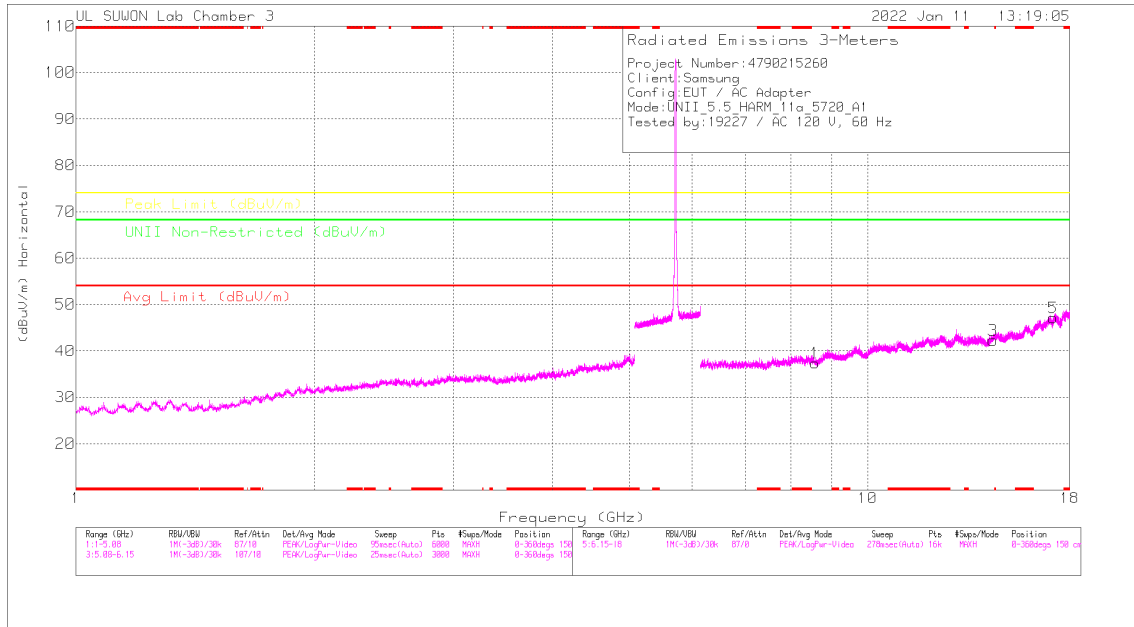

5720 MHz VERTICAL

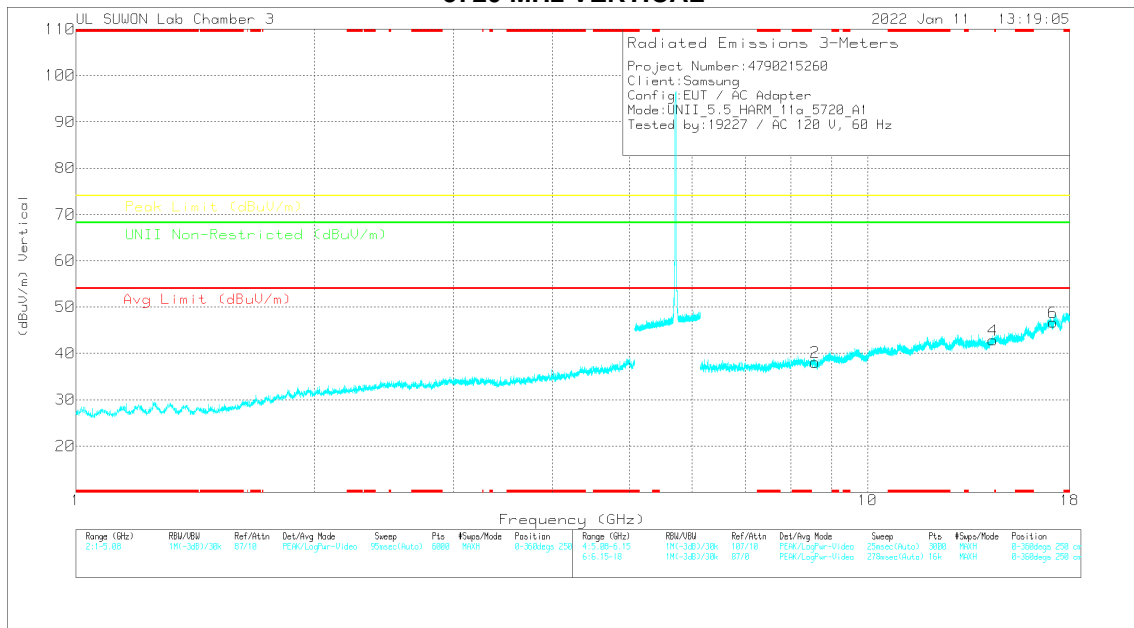

Note. Emission was scanned up to 40GHz; No emissions were detected above the noise floor which was at least 20dB below the specification limit.

Radiated Emissions

Frequency (GHz)	Meas Reading (dBuV)	Det	3117_00219807	60Hz_HPS(dB)	DC Corr (dB)	Corrected Reading (dBuV/m)	Avg Limit (dBuV/m)	Margin (dB)	Peak Limit (dBuV/m)	Margin (dB)	UNII Non-Restricted (dBuV/m)	Margin (dB)	Altitud (Degs)	Height (cm)	Polarity
8.584911	35.35	PK-U	38.5	-23.4	0	48.45	-	-	-	-	68.2	-19.75	360	100	H
8.57723	34.78	PK-U	38.5	-23.3	0	47.98	-	-	-	-	68.2	-20.22	360	100	V
14.39206	35.62	PK-U	39.8	-23.1	0	52.32	-	-	-	-	68.2	-15.88	360	100	H
14.4102	35.47	PK-U	39.8	-23	0	52.27	-	-	-	-	68.2	-15.93	360	100	V
17.16768	33.7	PK-U	42.2	-18.3	0	57.6	-	-	-	-	68.2	-10.6	360	100	H
17.15906	33.22	PK-U	42.2	-18.4	0	57.02	-	-	-	-	68.2	-11.18	360	100	V

PK-U - U-NII: Maximum Peak

HARMONICS AND SPURIOUS EMISSIONS TEST DATA

Mode	Freq. [MHz]	Antenna	Frequency [GHz]	Reading [dBuV]	Detector Mode	ANT Factor	Loss [dB]	DC Corr [dB]	Result [dBuV/m]	AV Limit [dBuV/m]	AV Margin [dB]	PK Limit [dBuV/m]	PK Margin [dB]	Non-Restricted [dBuV/m]	Margin [dB]	Azimuth [Degs]	Height [cm]	Polarity	
802.11a	5500	ANT1	* 8.23993	36.16	PK-U	36.20	-24.00	0.00	48.36	-	-	74.00	-25.64	-	-	360	100	H	
			* 8.24105	36.08	PK-U	36.20	-23.90	0.00	48.38	-	-	74.00	-25.62	-	-	360	100	V	
			* 11.0065	34.00	PK-U	38.50	-21.70	0.00	50.80	-	-	74.00	-23.20	-	-	360	100	H	
			* 10.99805	33.96	PK-U	38.50	-21.70	0.00	50.76	-	-	74.00	-23.24	-	-	360	100	V	
			16.491	33.39	PK-U	42.00	-19.80	0.00	55.59	-	-	-	-	-	68.20	-12.61	360	100	H
			16.510	33.74	PK-U	42.00	-19.60	0.00	56.14	-	-	-	-	-	68.20	-12.06	360	100	V
	5580	ANT1	* 8.36925	36.26	PK-U	36.20	-23.80	0.00	48.66	-	-	74.00	-25.34	-	-	360	100	H	
			* 8.36659	36.57	PK-U	36.20	-23.90	0.00	48.87	-	-	74.00	-25.13	-	-	360	100	V	
			* 11.16194	34.49	PK-U	38.60	-21.90	0.00	51.19	-	-	74.00	-22.81	-	-	360	100	H	
			* 11.15506	34.75	PK-U	38.60	-21.80	0.00	51.55	-	-	74.00	-22.45	-	-	360	100	V	
			16.740	32.19	PK-U	42.30	-19.10	0.00	55.39	-	-	-	-	-	68.20	-12.81	360	100	H
			16.736	32.42	PK-U	42.30	-19.20	0.00	55.52	-	-	-	-	-	68.20	-12.68	360	100	V
	5700	ANT1	8.555	35.07	PK-U	36.50	-23.20	0.00	48.37	-	-	-	-	68.20	-19.83	0	100	H	
			8.547	34.94	PK-U	36.50	-23.20	0.00	48.24	-	-	-	-	68.20	-19.96	0	100	V	
			* 11.39396	32.96	PK-U	38.60	-21.70	0.00	49.86	-	-	74.00	-24.14	-	-	0	100	H	
			* 11.39639	32.93	PK-U	38.60	-21.80	0.00	49.73	-	-	74.00	-24.27	-	-	0	100	V	
			17.111	32.69	PK-U	42.30	-18.60	0.00	56.39	-	-	-	-	-	68.20	-11.81	0	100	H
			17.107	33.12	PK-U	42.30	-18.50	0.00	56.92	-	-	-	-	-	68.20	-11.28	0	100	V
	5720	ANT1	8.585	35.35	PK-U	36.50	-23.40	0.00	48.45	-	-	-	-	68.20	-19.75	360	100	H	
			8.577	34.78	PK-U	36.50	-23.30	0.00	47.98	-	-	-	-	68.20	-20.22	360	100	V	
			14.392	35.62	PK-U	39.80	-23.10	0.00	52.32	-	-	-	-	68.20	-15.88	360	100	H	
			14.410	35.47	PK-U	39.80	-23.00	0.00	52.27	-	-	-	-	68.20	-15.93	360	100	V	
			17.168	33.70	PK-U	42.20	-18.30	0.00	57.60	-	-	-	-	68.20	-10.60	360	100	H	
			17.159	33.22	PK-U	42.20	-18.40	0.00	57.02	-	-	-	-	68.20	-11.18	360	100	V	

Note1. PK-U - U-NII: Maximum Peak / ADR - U-NII AD primary method, RMS average

Note2. * - indicates frequency in CFR47 Pt 15 / IC RSS-Restricted Band

11.4. TX ABOVE 1GHz 1Tx MODE IN THE 5.8 GHz BAND

BANDEDGE (WORST CASE: 802.11ac VHT80 LOWER SIDE / 5775 MHz)

HORIZONTAL PEAK DATA

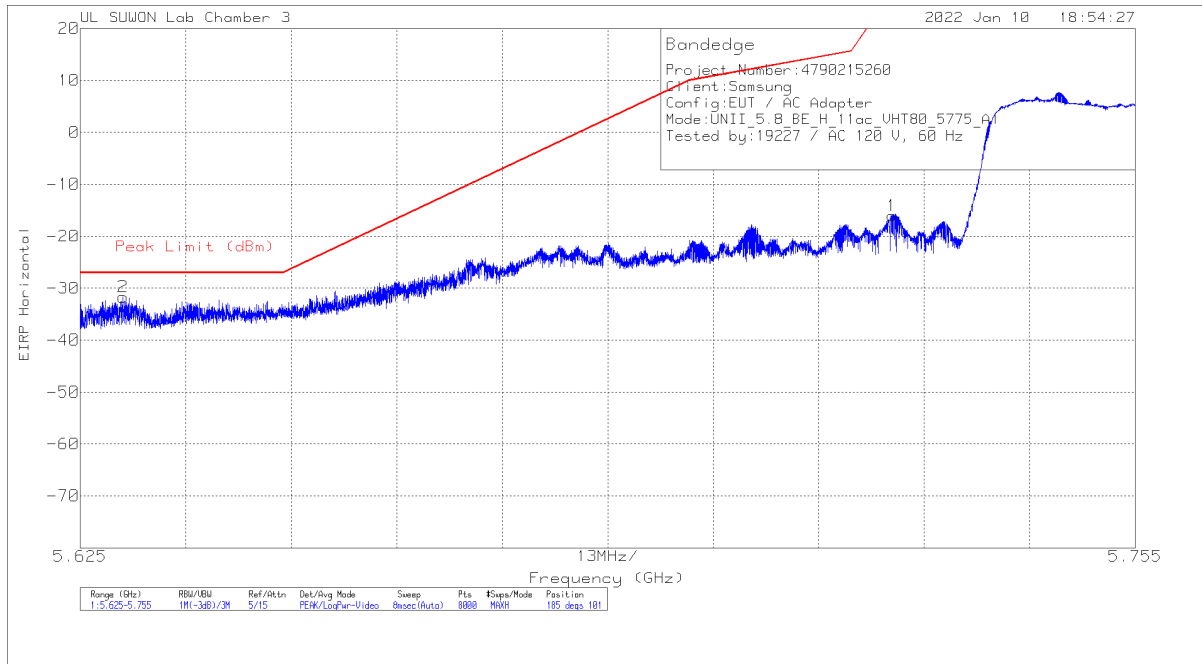

Trace Markers

Marker	Frequency (GHz)	Meter Reading (dBm)	Det	3117_00218957	10dB_ATT[dB]	Conversion Factor (dB)	DC Corr (dB)	Corrected Reading EIRP	Peak Limit (dBm)	PK Margin (dB)	Azimuth (Degs)	Height (cm)	Polarity
1	5.725	-43.48	Pk	35.6	-20	11.8	0	-16.08	27	-43.08	185	101	H
2	5.63028	-58.6	Pk	35.5	-20.4	11.8	0	-31.7	-27	-4.7	185	101	H

Pk - Peak detector

BANDEDGE TEST DATA

Mode	Freq. [MHz]	Antenna	Frequency [GHz]	Reading [dBm]	Detector Mode	ANT Factor	Loss [dB]	Conv. F [dB]	DC Corr [dB]	Result [dBm]	PK Limit [dBm]	PK Margin [dB]	Azimuth [Degs]	Height [cm]	Polarity
802.11a	5745	ANT1	5.72500	-46.05	Pk	35.60	-20.00	11.80	0.00	-18.65	27.00	-45.65	184	100	H
			5.63350	-63.19	Pk	35.50	-20.40	11.80	0.00	-36.29	-27.00	-9.29	184	100	H
			5.72500	-54.76	Pk	35.60	-20.00	11.80	0.00	-27.36	27.00	-54.36	169	230	V
			5.64021	-63.55	Pk	35.50	-20.30	11.80	0.00	-36.55	-27.00	-9.55	169	230	V
			5.85003	-60.18	Pk	35.10	-20.80	11.80	0.00	-34.08	26.94	-61.02	173	367	H
	5825	ANT1	5.93645	-64.75	Pk	35.20	-20.50	11.80	0.00	-38.25	-27.00	-11.25	173	367	H
			5.85003	-61.68	Pk	35.10	-20.80	11.80	0.00	-35.58	26.94	-62.52	127	132	V
			5.92963	-64.61	Pk	35.10	-20.50	11.80	0.00	-38.21	-27.00	-11.21	127	132	V
			5.72500	-41.66	Pk	35.60	-20.00	11.80	0.00	-14.26	27.00	-41.26	183	100	H
			5.63010	-63.46	Pk	35.50	-20.40	11.80	0.00	-36.56	-27.00	-9.56	183	100	H
802.11n (HT20)	5745	ANT1	5.72500	-50.43	Pk	35.60	-20.00	11.80	0.00	-23.03	27.00	-50.03	166	110	V
			5.64172	-63.26	Pk	35.50	-20.40	11.80	0.00	-36.36	-27.00	-9.36	166	110	V
			5.85003	-55.70	Pk	35.10	-20.80	11.80	0.00	-29.60	26.94	-56.54	175	100	H
			5.95315	-64.27	Pk	35.20	-20.50	11.80	0.00	-37.77	-27.00	-10.77	175	100	H
			5.85003	-62.49	Pk	35.10	-20.80	11.80	0.00	-36.39	26.94	-63.33	127	132	V
	5825	ANT1	5.96280	-65.28	Pk	35.20	-20.50	11.80	0.00	-38.78	-27.00	-11.78	127	132	V
			5.72500	-45.09	Pk	35.60	-20.00	11.80	0.00	-17.69	27.00	-44.69	182	100	H
			5.65004	-60.11	Pk	35.50	-20.20	11.80	0.00	-33.01	-26.97	-6.04	182	100	H
			5.72500	-53.44	Pk	35.60	-20.00	11.80	0.00	-26.04	27.00	-53.04	168	232	V
			5.64733	-63.45	Pk	35.50	-20.30	11.80	0.00	-36.45	-27.00	-9.45	168	232	V
802.11n (HT40)	5755	ANT1	5.85003	-60.58	Pk	35.10	-20.80	11.80	0.00	-34.48	26.94	-61.42	173	100	H
			5.92915	-62.93	Pk	35.10	-20.50	11.80	0.00	-36.53	-27.00	-9.53	173	100	H
			5.85003	-65.29	Pk	35.10	-20.80	11.80	0.00	-39.19	26.94	-66.13	126	122	V
			5.92943	-64.44	Pk	35.10	-20.50	11.80	0.00	-38.04	-27.00	-11.04	126	122	V
			5.72500	-43.48	Pk	35.60	-20.00	11.80	0.00	-16.08	27.00	-43.08	185	101	H
	5775 (Lower side)	ANT1	5.63028	-58.60	Pk	35.50	-20.40	11.80	0.00	-31.70	-27.00	-4.70	185	101	H
			5.72500	-55.51	Pk	35.60	-20.00	11.80	0.00	-28.11	27.00	-55.11	169	231	V
			5.64848	-62.83	Pk	35.50	-20.30	11.80	0.00	-35.83	-27.00	-8.83	169	231	V
			5.85003	-56.27	Pk	35.10	-20.80	11.80	0.00	-30.17	26.94	-57.11	179	101	H
			5.92855	-63.21	Pk	35.10	-20.50	11.80	0.00	-36.81	-27.00	-9.81	179	101	H
5775 (Upper Side)	ANT1	5.85003	-62.41	Pk	35.10	-20.80	11.80	0.00	-36.31	26.94	-63.25	123	137	V	
		5.98045	-64.81	Pk	35.20	-20.40	11.80	0.00	-38.21	-27.00	-11.21	123	137	V	
		5.85003	-62.41	Pk	35.10	-20.80	11.80	0.00	-36.31	26.94	-63.25	123	137	V	

Note. Pk - Peak detector

HARMONICS AND SPURIOUS EMISSIONS(WORST CASE: 802.11a / 5745 MHz)
5745 MHz HORIZONTAL

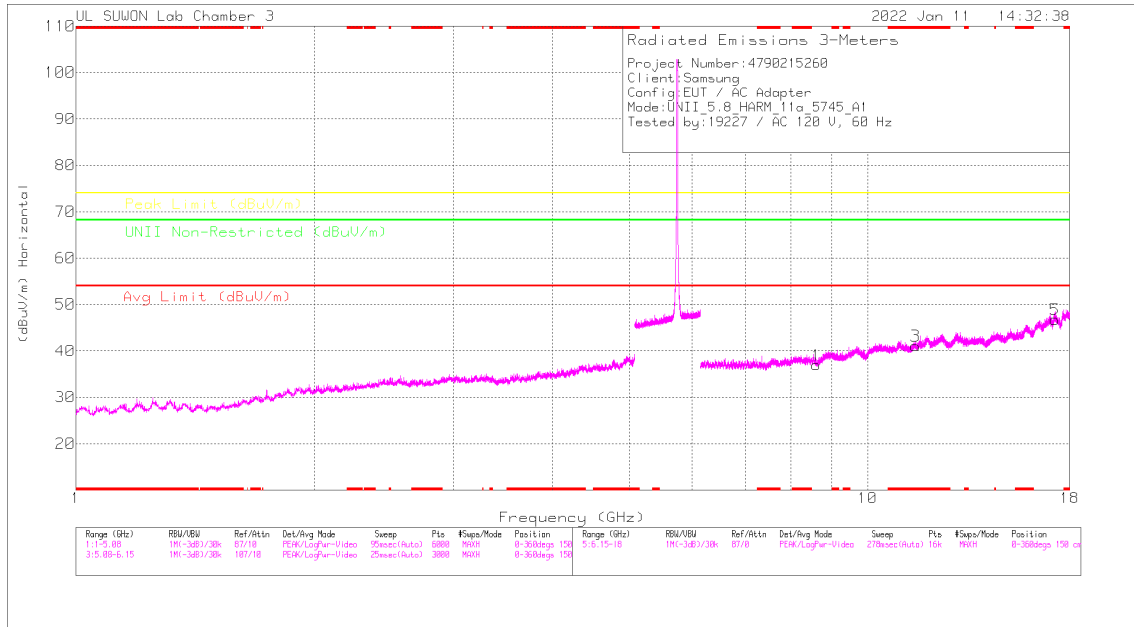

5745 MHz VERTICAL

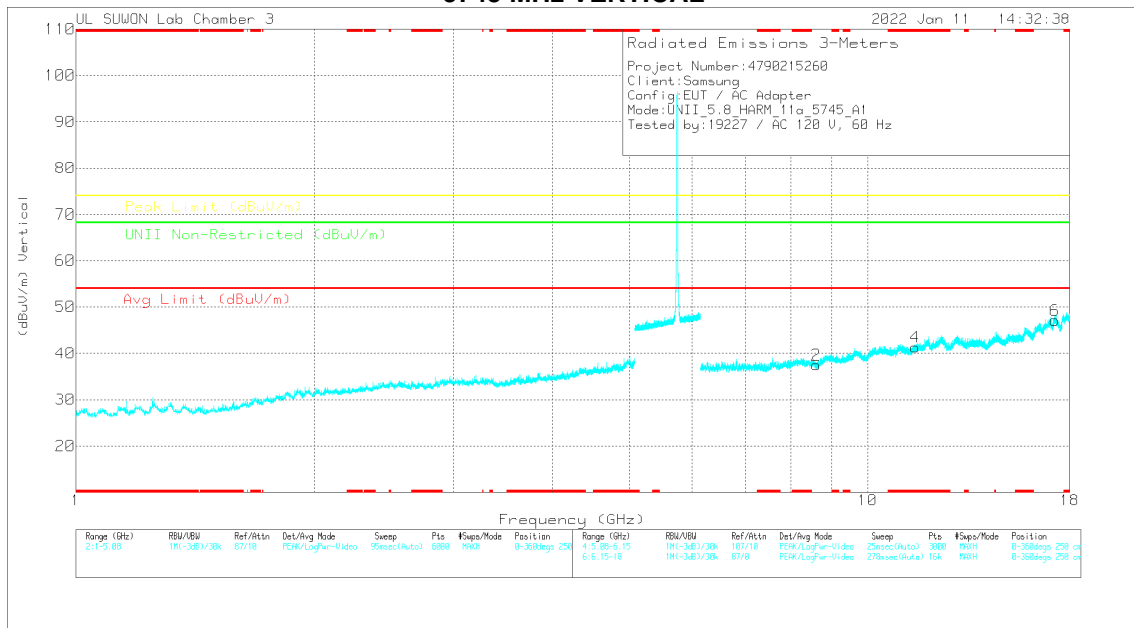

Note: Emission was scanned up to 40GHz; No emissions were detected above the noise floor which was at least 20dB below the specification limit.

Radiated Emissions

Frequency (GHz)	Meas Reading (dBuV)	Det	3117_00218667	6GHz_HF(SB)	DC Corr (dB)	Corrected Reading (dBuV/m)	Avg Limit (dBuV/m)	Margin (dB)	Peak Limit (dBuV/m)	Margin (dB)	UNII Non-Restricted (dBuV/m)	Margin (dB)	Altitud (Degs)	Height (cm)	Polarity
8.61229	34.8	PK-U	38.5	-23.4	0	47.9	-	-	-	-	68.2	-20.3	0	100	H
8.60867	34.97	PK-U	38.5	-23.4	0	48.07	-	-	-	-	68.2	-20.13	0	100	V
* 11.49536	33.5	PK-U	38.7	-21.7	0	50.5	-	-	74	-23.5	-	-	0	100	H
* 11.496	33.59	PK-U	38.7	-21.7	0	50.59	-	-	74	-23.41	-	-	0	100	V
17.23882	33.14	PK-U	42.1	-17.6	0	57.64	-	-	-	-	68.2	-10.56	0	100	H
17.24282	32.88	PK-U	42.1	-17.5	0	57.48	-	-	-	-	68.2	-10.72	0	100	V

* - indicates frequency in CFR47 Pt 15 / IC RSS-Restricted Band
 PK-U - U-NII: Maximum Peak

HARMONICS AND SPURIOUS EMISSIONS TEST DATA

Mode	Freq. [MHz]	Antenna	Frequency [GHz]	Reading [dBuV]	Detector Mode	ANT Factor	Loss [dB]	DC Corr [dB]	Result [dBuV/m]	AV Limit [dBuV/m]	AV Margin [dB]	PK Limit [dBuV/m]	PK Margin [dB]	Non-Restricted [dBuV/m]	Margin [dB]	Azimuth [Degs]	Height [cm]	Polarity	
802.11a	5745	ANT1	8.612	34.80	PK-U	36.50	-23.40	0.00	47.90	-	-	-	-	68.20	-20.30	0	100	H	
			8.610	34.97	PK-U	36.50	-23.40	0.00	48.07	-	-	-	-	68.20	-20.13	0	100	V	
			* 11.49536	33.50	PK-U	38.70	-21.70	0.00	50.50	-	-	74.00	-23.50	-	-	0	100	H	
			* 11.496	33.59	PK-U	38.70	-21.70	0.00	50.59	-	-	74.00	-23.41	-	-	0	100	V	
			17.240	33.14	PK-U	42.10	-17.60	0.00	57.64	-	-	-	-	-	68.20	-10.56	0	100	H
			17.243	32.88	PK-U	42.10	-17.50	0.00	57.48	-	-	-	-	-	68.20	-10.72	0	100	V
	5785	ANT1	8.679	35.31	PK-U	36.50	-23.30	0.00	48.51	-	-	-	-	68.20	-19.69	0	100	H	
			8.682	34.71	PK-U	36.50	-23.30	0.00	47.91	-	-	-	-	68.20	-20.29	0	100	V	
			* 11.57232	34.35	PK-U	38.80	-21.90	0.00	51.25	-	-	74.00	-22.75	-	-	0	100	H	
			* 11.57435	35.18	PK-U	38.80	-21.90	0.00	52.08	-	-	74.00	-21.92	-	-	0	100	V	
			17.365	32.50	PK-U	42.00	-17.70	0.00	56.80	-	-	-	-	-	68.20	-11.40	0	100	H
			17.363	32.31	PK-U	42.00	-17.70	0.00	56.61	-	-	-	-	-	68.20	-11.59	0	100	V
	5825	ANT1	8.735	35.33	PK-U	36.50	-23.10	0.00	48.73	-	-	-	-	68.20	-19.47	0	100	H	
			8.731	35.80	PK-U	36.50	-23.10	0.00	49.20	-	-	-	-	68.20	-19.00	0	100	V	
			* 11.65339	35.51	PK-U	38.90	-21.70	0.00	52.71	-	-	74.00	-21.29	-	-	0	100	H	
			* 11.64074	35.15	PK-U	38.80	-21.80	0.00	52.15	-	-	74.00	-21.85	-	-	0	100	V	
			17.478	31.52	PK-U	42.00	-17.40	0.00	56.12	-	-	-	-	-	68.20	-12.08	0	100	H
			17.483	31.54	PK-U	42.00	-17.50	0.00	56.04	-	-	-	-	-	68.20	-12.16	0	100	V

Note1. PK-U - U-NII: Maximum Peak / ADR - U-NII AD primary method, RMS average
 Note2. * - indicates frequency in CFR47 Pt 15 / IC RSS-Restricted Band

12. WORST-CASE BELOW 1 GHz

SPURIOUS EMISSIONS 30 TO 1000 MHz (WORST-CASE CONFIGURATION, HORIZONTAL)

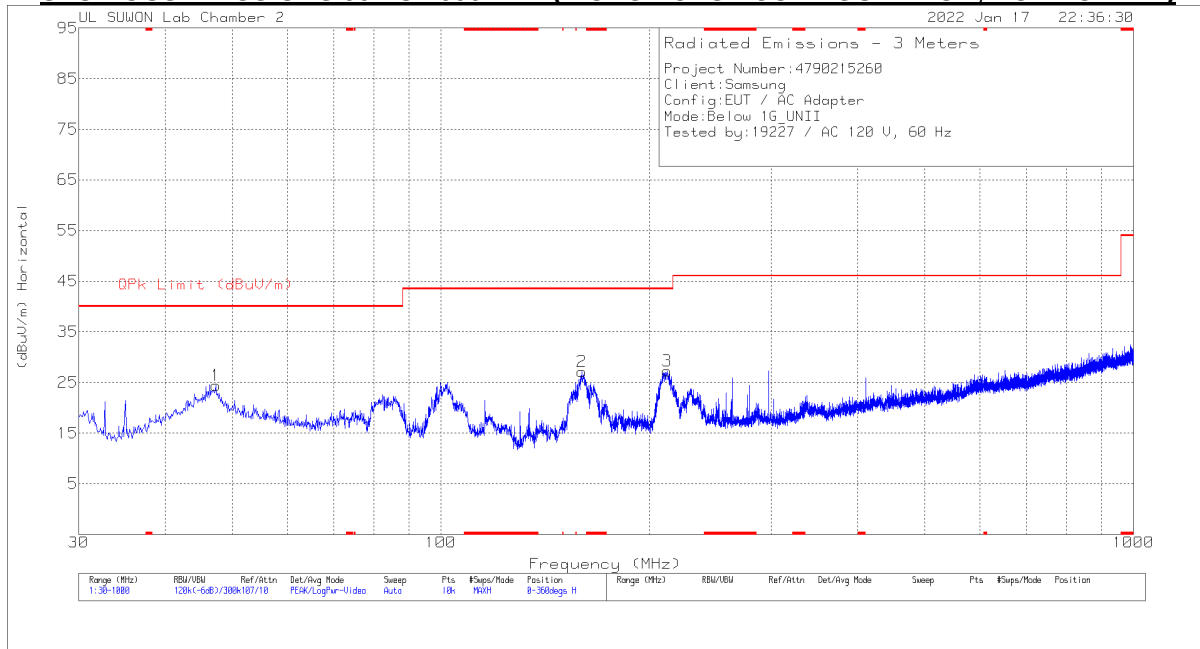

SPURIOUS EMISSIONS 30 TO 1000 MHz (WORST-CASE CONFIGURATION, VERTICAL)



Trace Markers

Marker	Frequency (MHz)	Meter Reading (dBuV)	Det	VULB9163_749	Below 1G[dB]	DC Corr (dB)	Corrected Reading (dBuV/m)	OPK Limit (dBuV/m)	Margin (dB)	Azimuth (Degs)	Height (cm)	Polarity
1	47.363	36.28	Pk	19.8	-31.7	0	24.38	40	-15.62	0-360	200	H
2	159.883	43.78	Pk	14.2	-30.9	0	27.08	43.52	-16.44	0-360	100	H
3	212.263	41.28	Pk	16.7	-30.7	0	27.28	43.52	-16.24	0-360	100	H
4	52.601	42.9	Pk	19.6	-31.6	0	30.9	40	-9.1	0-360	100	V
5	* 133.596	45.38	Pk	13.9	-31.1	0	28.18	43.52	-15.34	0-360	100	V
6	210.614	40.52	Pk	16.6	-30.7	0	26.42	43.52	-17.1	0-360	100	V

* - indicates frequency in CFR47 Pt 15 / IC RSS-Restricted Band
 Pk - Peak detector

13. AC POWER LINE CONDUCTED EMISSIONS

LIMITS

FCC §15.207 (a)
IC RSS-GEN Clause 8.8

Frequency of Emission (MHz)	Conducted Limit (dBuV)	
	Quasi-peak	Average
0.15-0.5	66 to 56 [*]	56 to 46 [*]
0.5-5	56	46
5-30	60	50

^{*}Decreases with the logarithm of the frequency.

TEST PROCEDURE

The EUT is placed on a non-conducting table 40 cm from the vertical ground plane and 80 cm above the horizontal ground plane. The EUT is configured in accordance with ANSI C63.10.

The receiver is set to a resolution bandwidth of 9 kHz. Peak detection is used unless otherwise noted as quasi-peak or average.

Line conducted data is recorded for both NEUTRAL and HOT lines.

RESULTS

WORST EMISSIONS

LINE 1 DATA

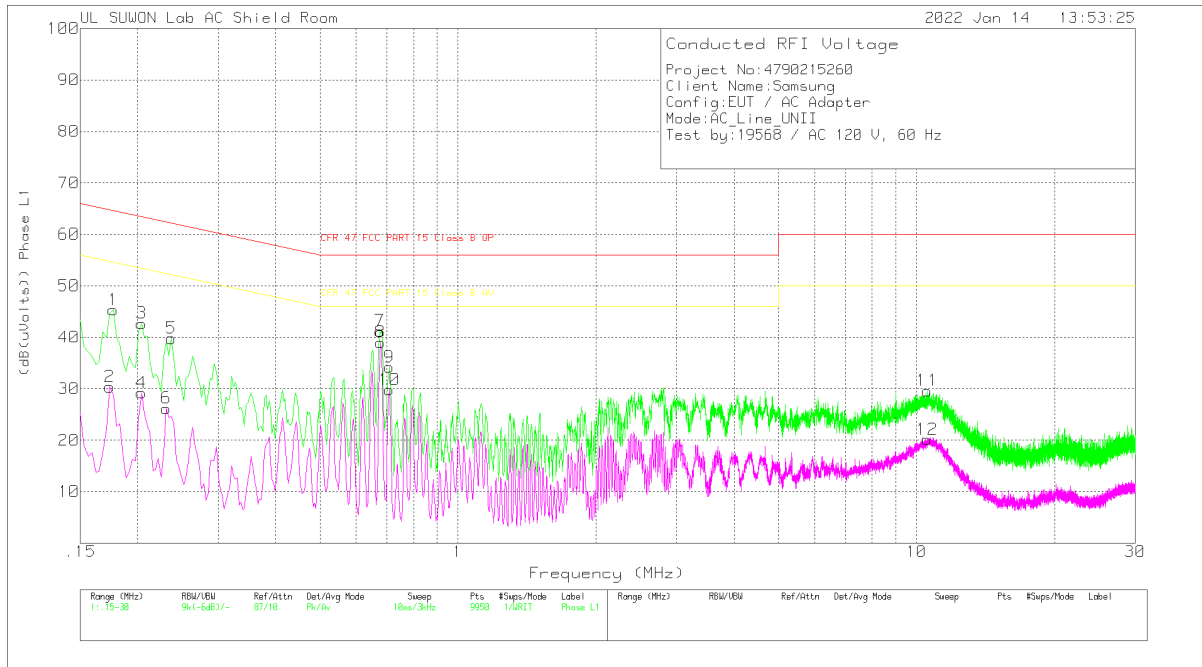

Trace Markers

Range 1: Phase L1 .15 - 30MHz

Marker	Frequency (MHz)	Meter Reading (dBuV)	Det	101836_With EX_L1[dB]	CABLELOS S(dB)	Corrected Reading (dB(uVolts))	CFR 47 FCC PART 15 Class B QP	Margin (dB)	CFR 47 FCC PART 15 Class B AV	Margin (dB)
1	.177	35.23	Pk	9.9	.2	45.33	64.63	-19.3	-	-
2	.174	20.18	Av	10	.2	30.38	-	-	54.77	-24.39
3	.204	32.7	Pk	9.8	.2	42.7	63.45	-20.75	-	-
4	.204	19.18	Av	9.8	.2	29.18	-	-	53.45	-24.27
5	.237	29.89	Pk	9.7	.2	39.79	62.2	-22.41	-	-
6	.231	16.3	Av	9.7	.2	26.2	-	-	52.41	-26.21
7	.675	31.22	Pk	9.8	.2	41.22	56	-14.78	-	-
8	.678	29.04	Av	9.8	.2	39.04	-	-	46	-6.96
9	.708	24.19	Pk	9.8	.2	34.19	56	-21.81	-	-
10	.708	19.8	Av	9.8	.2	29.8	-	-	46	-16.2
11	10.563	19.32	Pk	9.9	.4	29.62	60	-30.38	-	-
12	10.557	9.82	Av	9.9	.4	20.12	-	-	50	-29.88

Pk - Peak detector

Av - Average detection

Quasi-Peak Emissions

Range 1: Phase L1 .15 - 30MHz

Frequency (MHz)	Meter Reading (dBuV)	Det	101836_With EX_L1[dB]	CABLELOS S(dB)	Corrected Reading (dB(uVolts))	CFR 47 FCC PART 15 Class B QP	Margin (dB)	CFR 47 FCC PART 15 Class B AV	Margin (dB)
.67875	28.13	Qp	9.8	.2	38.13	56	-17.87	-	-

LINE 2 DATA

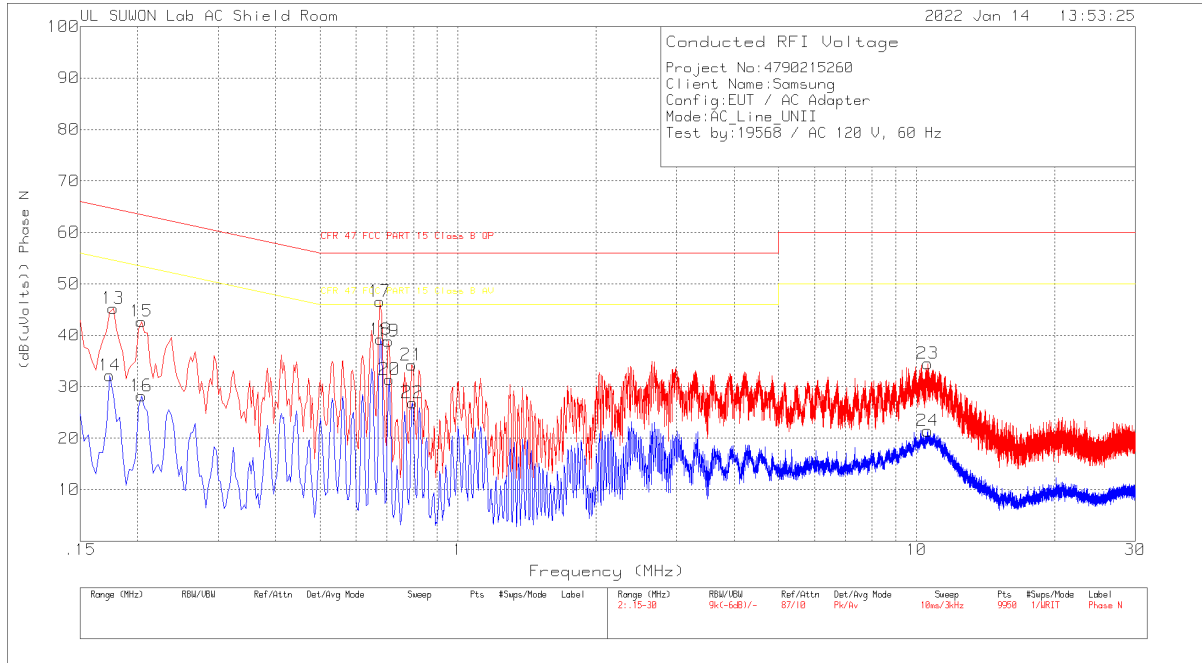

Trace Markers

Range 2: Phase N .15 - 30MHz

Marker	Frequency (MHz)	Meter Reading (dBuV)	Det	101836_With EX_N[dB]	CABLELOS S(dB)	Corrected Reading (dB(uVolts))	CFR 47 FCC PART 15 Class B QP	Margin (dB)	CFR 47 FCC PART 15 Class B AV	Margin (dB)
13	.177	35.14	Pk	9.9	.2	45.24	64.63	-19.39	-	-
14	.174	22	Av	10	.2	32.2	-	-	54.77	-22.57
15	.204	32.7	Pk	9.8	.2	42.7	63.45	-20.75	-	-
16	.204	18.24	Av	9.8	.2	28.24	-	-	53.45	-25.21
17	.675	36.59	Pk	9.8	.2	46.59	56	-9.41	-	-
18	.678	29.21	Av	9.8	.2	39.21	-	-	46	-6.79
19	.705	28.89	Pk	9.8	.2	38.89	56	-17.11	-	-
20	.708	21.43	Av	9.8	.2	31.43	-	-	46	-14.57
21	.792	24.24	Pk	9.8	.2	34.24	56	-21.76	-	-
22	.795	16.91	Av	9.8	.2	26.91	-	-	46	-19.09
23	10.572	24.22	Pk	9.9	.4	34.52	60	-25.48	-	-
24	10.572	11.15	Av	9.9	.4	21.45	-	-	50	-28.55

Pk - Peak detector

Av - Average detection

Quasi-Peak Emissions

Range 2: Phase N .15 - 30MHz

Frequency (MHz)	Meter Reading (dBuV)	Det	101836_With EX_N[dB]	CABLELOS S(dB)	Corrected Reading (dB(uVolts))	CFR 47 FCC PART 15 Class B QP	Margin (dB)	CFR 47 FCC PART 15 Class B AV	Margin (dB)
.67575	25.56	Qp	9.8	.2	35.56	56	-20.44	-	-
.67875	33.06	Qp	9.8	.2	43.06	56	-12.94	-	-

Qp - Quasi-Peak detector

14. DYNAMIC FREQUENCY SELECTION

14.1. OVERVIEW

14.1.1. LIMITS

FCC

§15.407 (h), FCC KDB 905462 D02 “COMPLIANCE MEASUREMENT PROCEDURES FOR UNLICENSED-NATIONAL INFORMATION INFRASTRUCTURE DEVICES OPERATING IN THE 5250-5350 MHz AND 5470-5725 MHz BANDS INCORPORATING DYNAMIC FREQUENCY SELECTION” and KDB 905462 D03 “U-NII CLIENT DEVICES WITHOUT RADAR DETECTION CAPABILITY”.

Table 1: Applicability of DFS requirements prior to use of a channel

Requirement	Operational Mode		
	Master	Client (without radar detection)	Client (with radar detection)
Non-Occupancy Period	Yes	Not required	Yes
DFS Detection Threshold	Yes	Not required	Yes
Channel Availability Check Time	Yes	Not required	Not required
U-NII Detection Bandwidth	Yes	Not required	Yes

Table 2: Applicability of DFS requirements during normal operation

Requirement	Operational Mode		
	Master	Client (without DFS)	Client (with DFS)
DFS Detection Threshold	Yes	Not required	Yes
Channel Closing Transmission Time	Yes	Yes	Yes
Channel Move Time	Yes	Yes	Yes
U-NII Detection Bandwidth	Yes	Not required	Yes

Additional requirements for devices with multiple bandwidth modes	Master Device or Client with Radar DFS	Client (without DFS)
U-NII Detection Bandwidth and Statistical Performance Check	All BW modes must be tested	Not required
Channel Move Time and Channel Closing Transmission Time	Test using widest BW mode available	Test using the widest BW mode available for the link
All other tests	Any single BW mode	Not required

Note: Frequencies selected for statistical performance check (Section 7.8.4) should include several frequencies within the radar detection bandwidth and frequencies near the edge of the radar detection bandwidth. For 802.11 devices it is suggested to select frequencies in all 20 MHz channel blocks and a null frequency between the bonded 20 MHz channel blocks.

Table 3: Interference Threshold values, Master or Client incorporating In-Service Monitoring

Maximum Transmit Power	Value (see notes)
E.I.R.P. \geq 200 mill watt	-64 dBm
E.I.R.P. < 200 mill watt and power spectral density < 10 dBm/MHz	-62 dBm
E.I.R.P. < 200 mill watt that do not meet power spectral density requirement	-64 dBm
<p>Note 1: This is the level at the input of the receiver assuming a 0 dBi receive antenna Note 2: Throughout these test procedures an additional 1 dB has been added to the amplitude of the test transmission waveforms to account for variations in measurement equipment. This will ensure that the test signal is at or above the detection threshold level to trigger a DFS response. Note 3: E.I.R.P. is based on the highest antenna gain. For MIMO devices refer to KDB publication 662911 D01.</p>	

Table 4: DFS Response requirement values

Parameter	Value
<i>Non-occupancy period</i>	30 minutes
<i>Channel Availability Check Time</i>	60 seconds
<i>Channel Move Time</i>	10 seconds (See Note 1)
<i>Channel Closing Transmission Time</i>	200 milliseconds + approx. 60 milliseconds over remaining 10 second period. (See Notes 1 and 2)
<i>U-NII Detection Bandwidth</i>	Minimum 100% of the U- NII 99% transmission power bandwidth. (See Note 3)
<p>Note 1: <i>Channel Move Time</i> and the <i>Channel Closing Transmission Time</i> should be performed with Radar Type 0. The measurement timing begins at the end of the Radar Type 0 burst. Note 2: The <i>Channel Closing Transmission Time</i> is comprised of 200 milliseconds starting at the beginning of the <i>Channel Move Time</i> plus any additional intermittent control signals required to facilitate a <i>Channel</i> move (an aggregate of 60 milliseconds) during the remainder of the 10 second period. The aggregate duration of control signals will not count quiet periods in between transmissions. Note 3: During the <i>U-NII Detection Bandwidth</i> detection test, radar type 0 should be used. For each frequency step the minimum percentage of detection is 90 percent. Measurements are performed with no data traffic.</p>	

Table 5 – Short Pulse Radar Test Waveforms

Radar Type	Pulse Width (usec)	PRI (usec)	Pulses	Minimum Percentage of Successful Detection	Minimum Trials
0	1	1428	18	See Note 1	See Note 1
1	1	Test A: 15 unique PRI values randomly selected from the list of 23 PRI values in table 5a	Roundup: $\{(1/360) \times (19 \times 10^6 \text{ PRI}_{\text{usec}})\}$	60%	30
		Test B: 15 unique PRI values randomly selected within the range of 518-3066 usec. With a minimum increment of 1 usec, excluding PRI values selected in Test A			
2	1-5	150-230	23-29	60%	30
3	6-10	200-500	16-18	60%	30
4	11-20	200-500	12-16	60%	30
Aggregate (Radar Types 1-4)				80%	120
Note 1: Short Pulse Radar Type 0 should be used for the <i>Detection Bandwidth</i> test, <i>Channel Move Time</i> , and <i>Channel Closing Time</i> tests.					

Table 6 – Long Pulse Radar Test Signal

Radar Waveform Type	Pulse Width (μsec)	Chirp Width (MHz)	PRI (μsec)	Pulses per Burst	Number of Bursts	Minimum Percentage of Successful Detection	Minimum Trials
5	50-100	5-20	1000-2000	1-3	8-20	80%	30

Table 7 – Frequency Hopping Radar Test Signal

Radar Waveform Type	Pulse Width (μsec)	PRI (μsec)	Pulses per Hop	Hopping Rate (kHz)	Hopping Sequence Length (msec)	Minimum Percentage of Successful Detection	Minimum Trials
6	1	333	9	0.333	300	70%	30

14.1.2. TEST AND MEASUREMENT SYSTEM

CONDUCTED METHOD SYSTEM BLOCK DIAGRAM

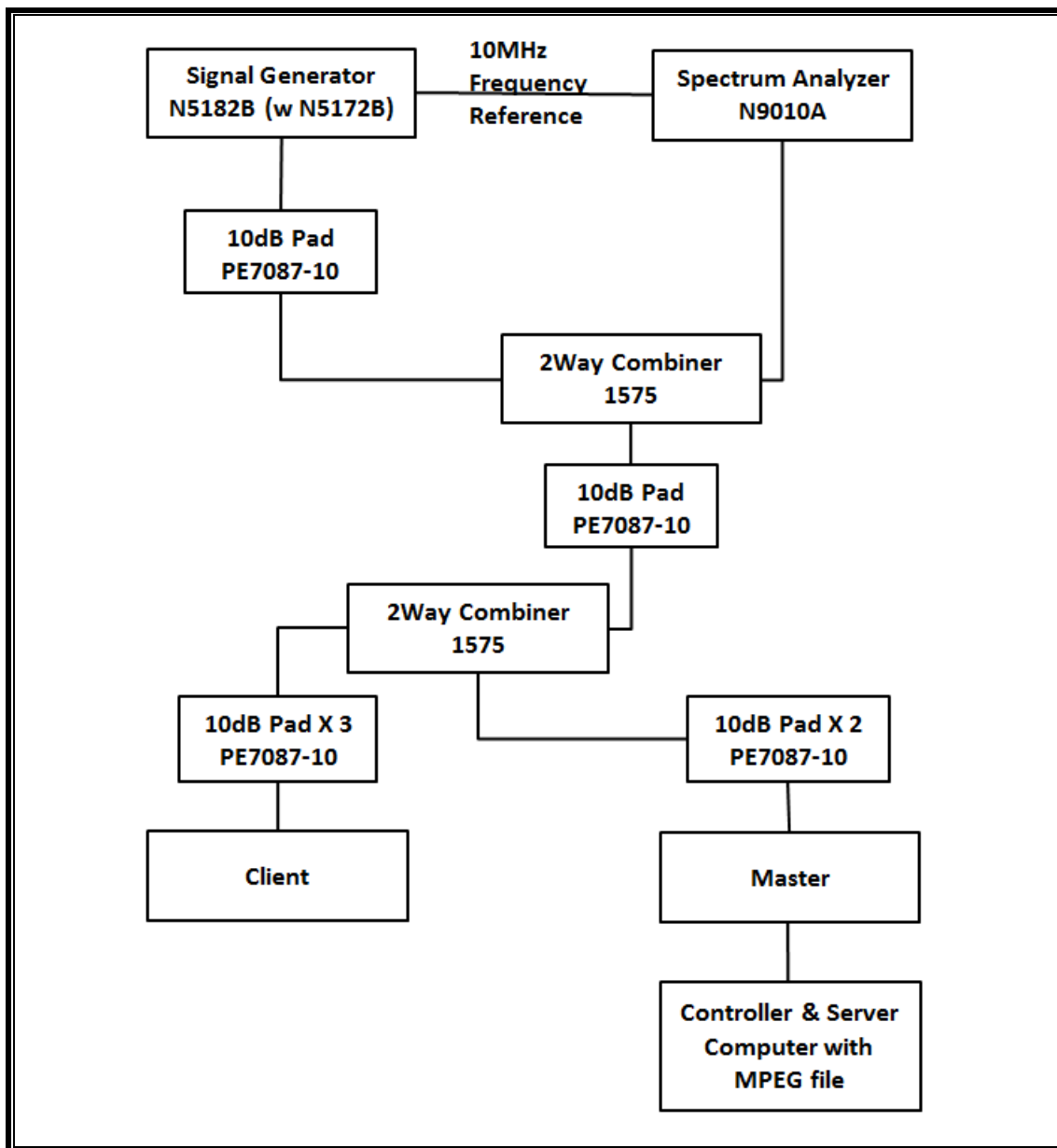

SYSTEM OVERVIEW

The short pulse and long pulse signal generating system utilizes the Keysite Signal Studio for Pulse Building as N5172B. The Vector Signal Generator has been validated by the NTIA. The hopping signal generating system utilizes the CCS simulated hopping method and system, which has been validated by the DoD, FCC and NTIA. The software selects waveform parameters from within the bounds of the signal type on a random basis using uniform distribution.

The short pulse types 1, 2, 3 and 4, and the long pulse type 5 parameters are randomized at run-time.

The hopping type 6 pulse parameters are fixed while the hopping sequence is based on the August 2005 NTIA Hopping Frequency List. The initial starting point randomized at run-time and each subsequent starting point is incremented by 475. Each frequency in the 100-length segment is compared to the boundaries of the EUT Detection Bandwidth and the software creates a hopping burst pattern in accordance with Section 7.4.1.3 Method #2 Simulated Frequency Hopping Radar Waveform Generating Subsystem of KDB 905462 D02. The frequency of the signal generator is incremented in 1 MHz steps from F_L to F_H for each successive trial. This incremental sequence is repeated as required to generate a minimum of 30 total trials and to maintain a uniform frequency distribution over the entire Detection Bandwidth.

The signal monitoring equipment consists of a spectrum analyzer. The aggregate ON time is calculated by multiplying the number of bins above a threshold during a particular observation period by the dwell time per bin, with the analyzer set to peak detection and max hold.

SYSTEM CALIBRATION

A 50-ohm load is connected in place of the spectrum analyzer, and the spectrum analyzer is connected to a horn antenna via a coaxial cable, with the reference level offset set to (horn antenna gain – coaxial cable loss). The signal generator is set to CW mode. The amplitude of the signal generator is adjusted to yield a level of –64 dBm as measured on the spectrum analyzer.

Without changing any of the instrument settings, the spectrum analyzer is reconnected to the Common port of the Spectrum Analyzer Combiner/Divider. The Reference Level Offset of the spectrum analyzer is adjusted so that the displayed amplitude of the signal is –64 dBm.

The spectrum analyzer displays the level of the signal generator as received at the antenna ports of the Master Device. The interference detection threshold may be varied from the calibrated value of –64 dBm and the spectrum analyzer will still indicate the level as received by the Master Device.

ADJUSTMENT OF DISPLAYED TRAFFIC LEVEL

A link is established between the Master and Slave and the distance between the units is adjusted as needed to provide a suitable received level at the Master and Slave devices. The video test file is streamed to generate WLAN traffic. The monitoring antenna is adjusted so that the WLAN traffic level, as displayed on the spectrum analyzer, is at lower amplitude than the radar detection threshold.

TEST AND MEASUREMENT EQUIPMENT

The following test and measurement equipment was utilized for the DFS tests documented in this report:

TEST EQUIPMENT LIST				
Description	Manufacturer	Model	S/N	Next Cal Due
Spectrum Analyzer, 7 GHz	Agilent / HP	N9010A	MY54200580	08-02-22
Vector Signal Generator, 6GHz	Agilent / HP	N5182B	MY53051241	08-02-22
Combiner	WEINSCHTEL	WA1534	UL003	01-11-23
Combiner	WEINSCHTEL	WA1535	UL004	01-11-23

14.1.3. SETUP OF EUT

CONDUCTED METHOD EUT TEST SETUP

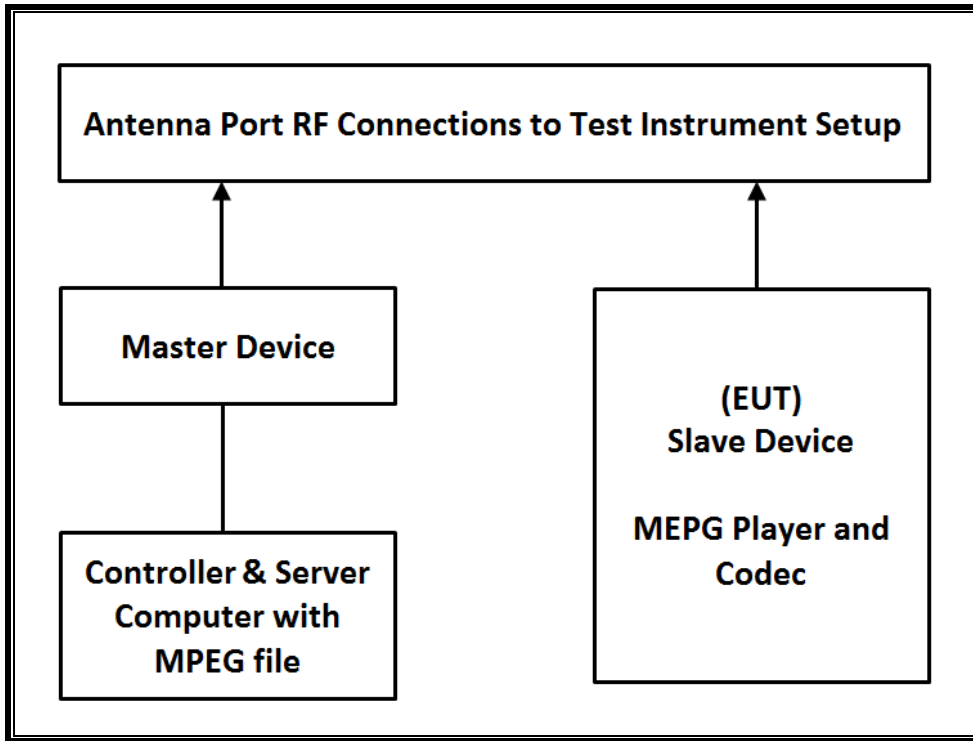

SUPPORT EQUIPMENT

The following support equipment was utilized for the DFS tests documented in this report:

PERIPHERAL SUPPORT EQUIPMENT LIST				
Description	Manufacturer	Model	Serial Number	FCC ID
Wireless Access Point	Cisco	AIR-CAP3702E-A-K9	FTX182276QX	LDK102087
Notebook PC (Controller/Server)	HP	HP EliteDesk 800 G1 TWR	CZC4125J25	DoC

14.1.4. DESCRIPTION OF EUT

The EUT operates over the 5250-5350 MHz and 5470-5725 MHz ranges.

The EUT is a Slave Device without Radar Detection.

The highest power level of the widest bandwidth (802.11ac VHT80) within these bands is 10.25 dBm in the 5250-5350 MHz band and 10.83 dBm in the 5470-5725 MHz band.

The antenna assembly utilized two antenna.

Gain of ANT: -4.92 dBi for UNII 2A and -4.88 dBi for UNII 2C.

The rated output power of the Master unit is > 23dBm (EIRP). Therefore the required interference threshold level is -64 dBm. After correction for procedural adjustments, the required conducted threshold at the antenna port is $-64 + 1 = -63$ dBm.

The calibrated radiated DFS Detection Threshold level is set to -64 dBm. The tested level is lower than the required level hence it provides a margin to the limit.

The EUT uses one transmitter/receiver chain connected to an antenna to perform radiated tests. WLAN traffic that meets or exceeds the minimum required loading was generated by transferring a data stream from the controller/server PC to the EUT using iPerf version 2.0.5 software package.

TPC is not required since the maximum EIRP is less than 500 mW (27 dBm).

The EUT utilizes the 802.11 architecture. Three nominal channel bandwidths are implemented: 20 MHz, 40 MHz and 80 MHz.

The software installed in the access point is 12.4(25d)JA1.

UNIFORM CHANNEL SPREADING

This requirement is not applicable to Slave radio devices.

OVERVIEW OF MASTER DEVICE WITH RESPECT TO §15.407 (h) REQUIREMENTS

The Master Device is a Cisco Access Point, FCC ID: LDK102087. The minimum antenna gain for the Master Device is 6 dBi.

The rated output power of the Master unit is > 23dBm (EIRP). Therefore the required interference threshold level is -64 dBm. After correction for procedural adjustments, the required radiated threshold at the antenna port is $-64 + 1 = -63$ dBm.

The calibrated radiated DFS Detection Threshold level is set to -64 dBm. The tested level is lower than the required level hence it provides a margin to the limit.

14.2. RESULTS FOR 80 MHz BANDWIDTH (UNII-2A BAND)

14.2.1. TEST CHANNEL

All tests were performed at a channel center frequency of 5290 MHz.

14.2.2. RADAR WAVEFORM AND TRAFFIC

RADAR WAVEFORM

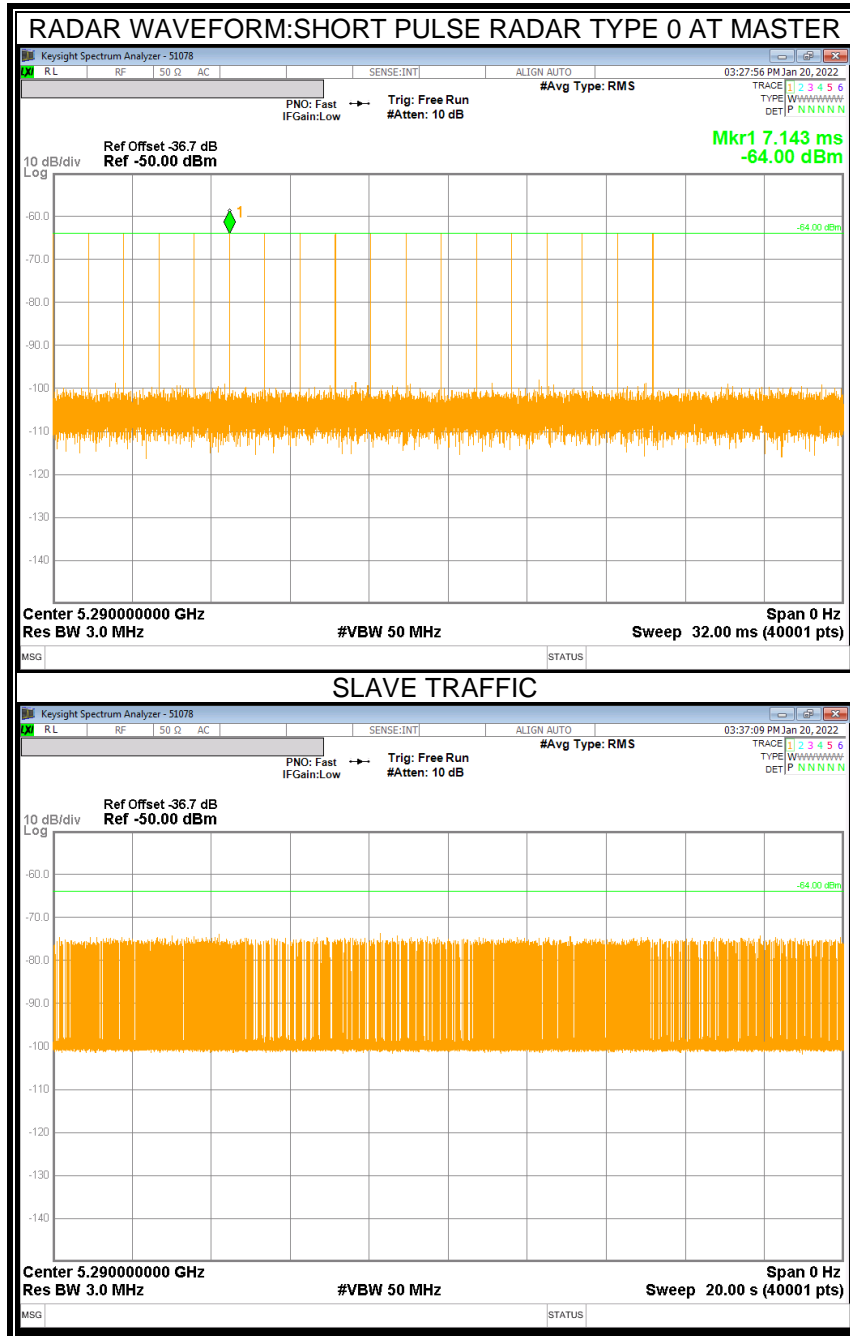

14.2.3. OVERLAPPING CHANNEL TESTS

RESULTS

These tests are not applicable.

14.2.4. MOVE AND CLOSING TIME

REPORTING NOTES

The reference marker is set at the end of last radar pulse.

The delta marker is set at the end of the last WLAN transmission following the radar pulse. This delta is the channel move time.

The aggregate channel closing transmission time is calculated as follows:

Aggregate Transmission Time =
(Number of analyzer bins showing transmission) * (dwell time per bin)

The observation period over which the aggregate time is calculated begins at (Reference Marker + 200 msec) and ends no earlier than (Reference Marker + 10 sec).

RESULTS

Channel Move Time (sec)	Limit (sec)
0.746	10

Aggregate Channel Closing Transmission Time (msec)	Limit (msec)
4.125	60

MOVE TIME & CHANNEL CLOSING TIME

AGGREGATE CHANNEL CLOSING TRANSMISSION TIME

No transmissions are observed during the aggregate monitoring period.

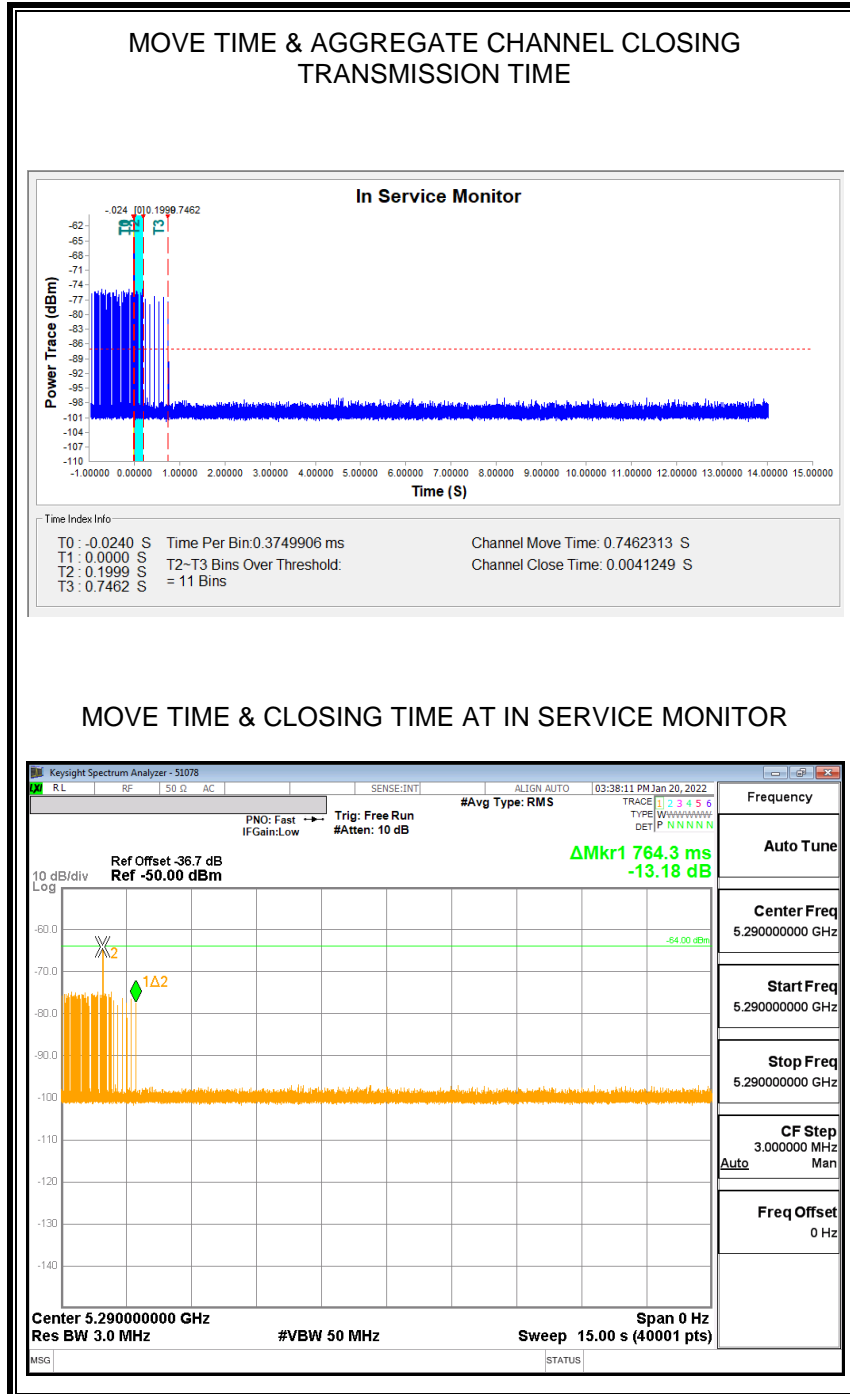

NON-OCCUPANCY PERIOD

RESULTS

No EUT transmissions were observed on the test channel during the 10-minute observation time.

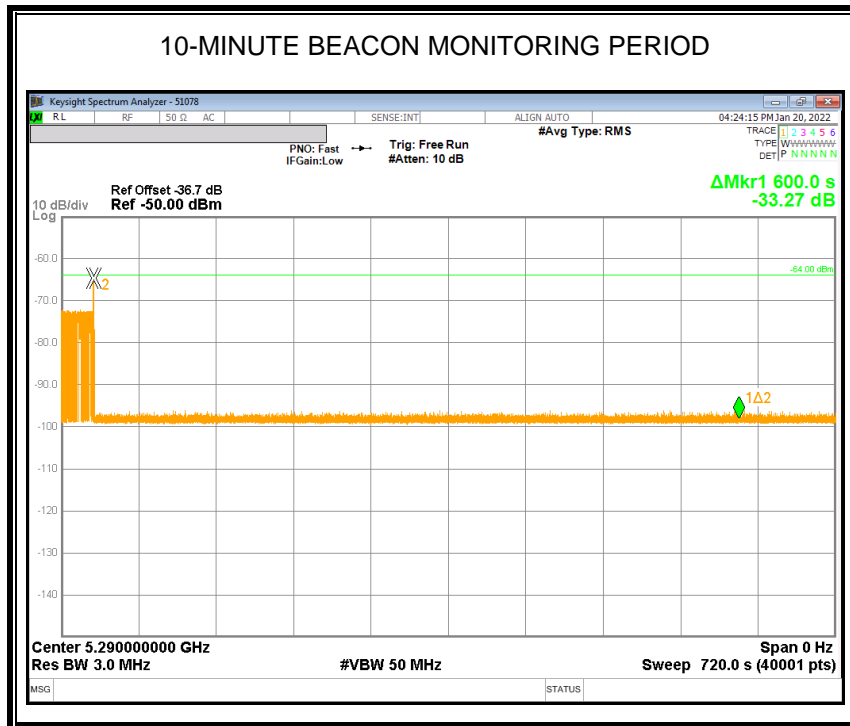

14.3. RESULTS FOR 80 MHz BANDWIDTH (UNII-2C BAND)

14.3.1. TEST CHANNEL

All tests were performed at a channel center frequency of 5530 MHz.

14.3.2. RADAR WAVEFORM AND TRAFFIC

RADAR WAVEFORM

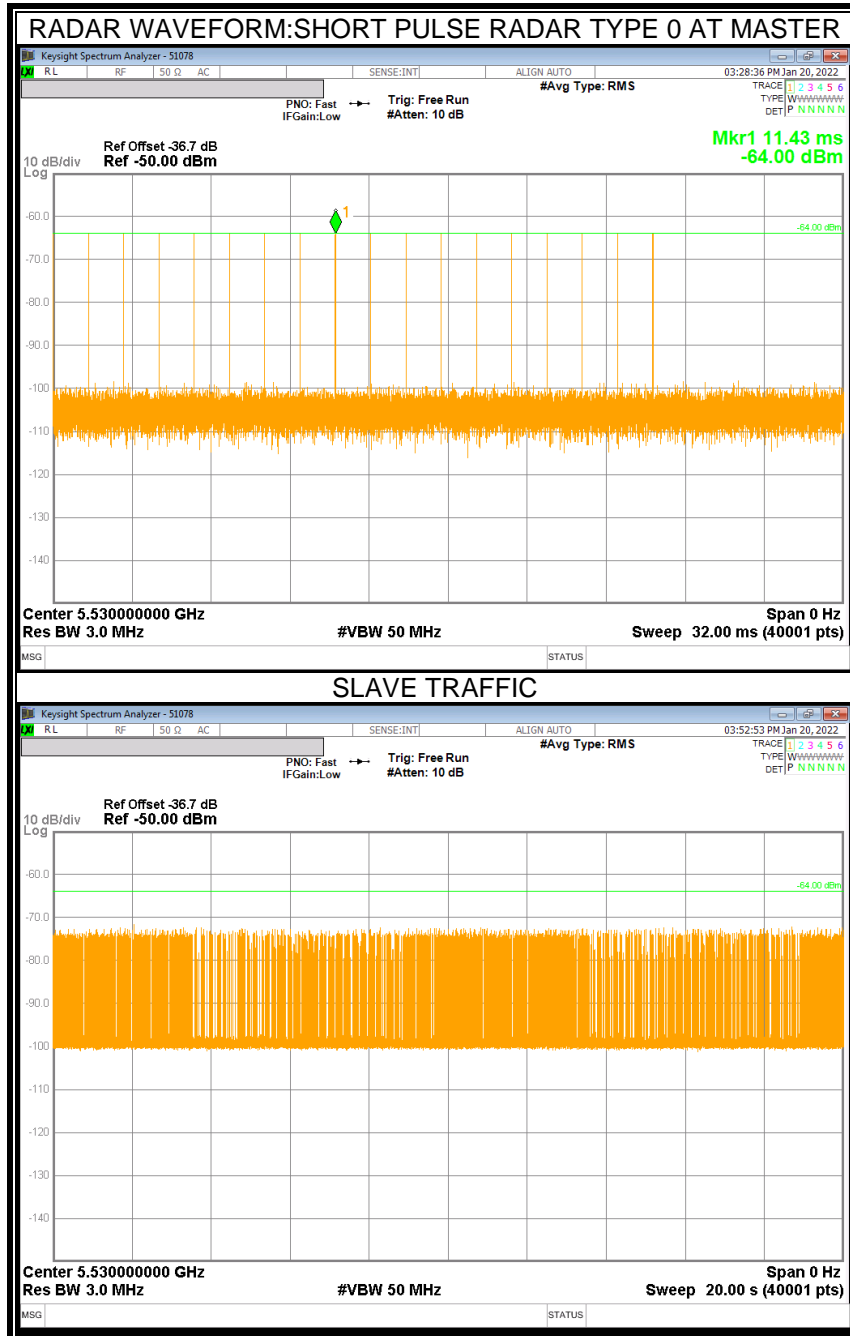

14.3.3. OVERLAPPING CHANNEL TESTS

RESULTS

These tests are not applicable.

14.3.4. MOVE AND CLOSING TIME

REPORTING NOTES

The reference marker is set at the end of last radar pulse.

The delta marker is set at the end of the last WLAN transmission following the radar pulse. This delta is the channel move time.

The aggregate channel closing transmission time is calculated as follows:

Aggregate Transmission Time =
(Number of analyzer bins showing transmission) * (dwell time per bin)

The observation period over which the aggregate time is calculated begins at (Reference Marker + 200 msec) and ends no earlier than (Reference Marker + 10 sec).

RESULTS

Channel Move Time (sec)	Limit (sec)
0.799	10

Aggregate Channel Closing Transmission Time (msec)	Limit (msec)
4.875	60

MOVE TIME & CHANNEL CLOSING TIME

AGGREGATE CHANNEL CLOSING TRANSMISSION TIME

No transmissions are observed during the aggregate monitoring period.

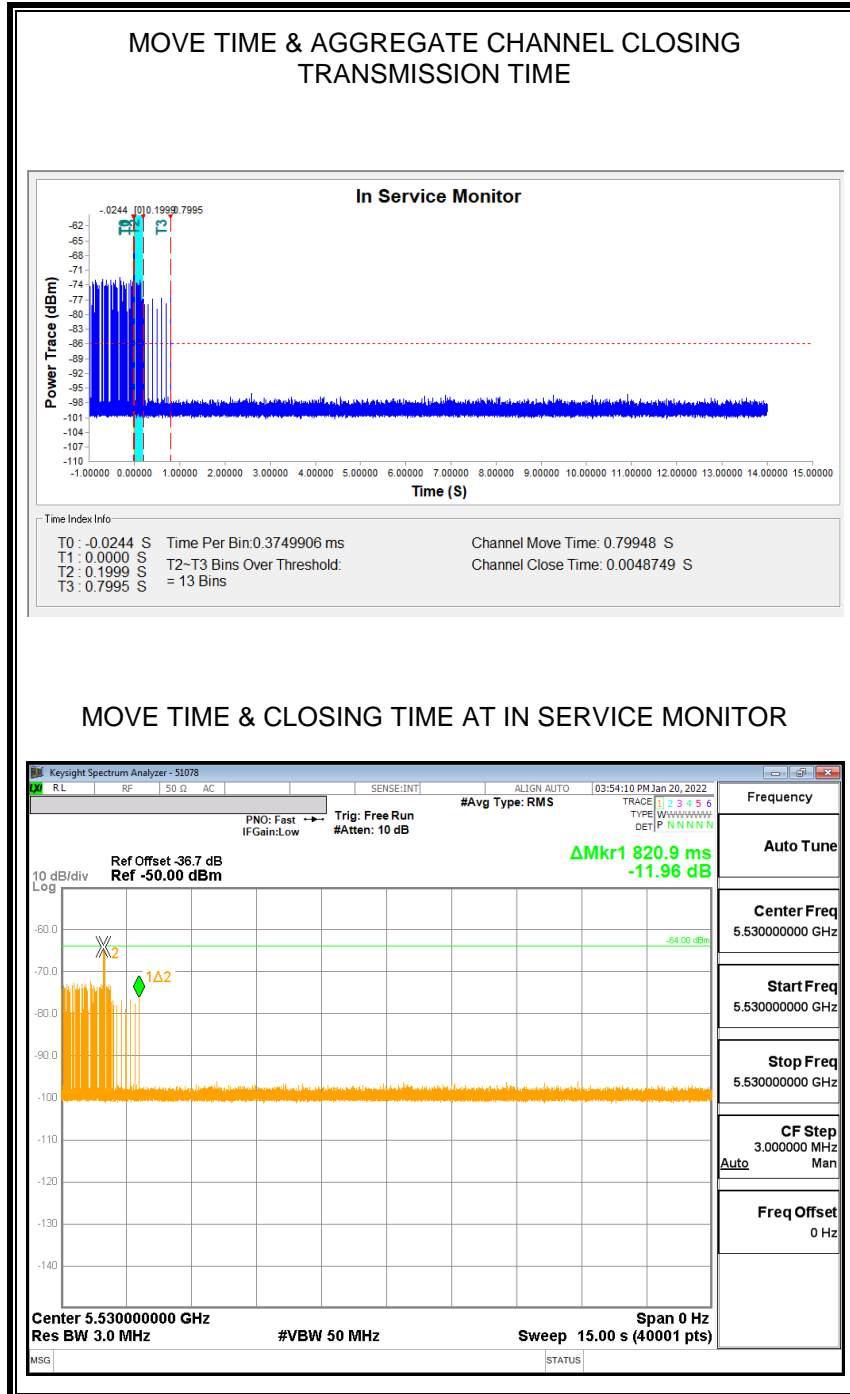

NON-OCCUPANCY PERIOD

RESULTS

No EUT transmissions were observed on the test channel during the 10-minute observation time.

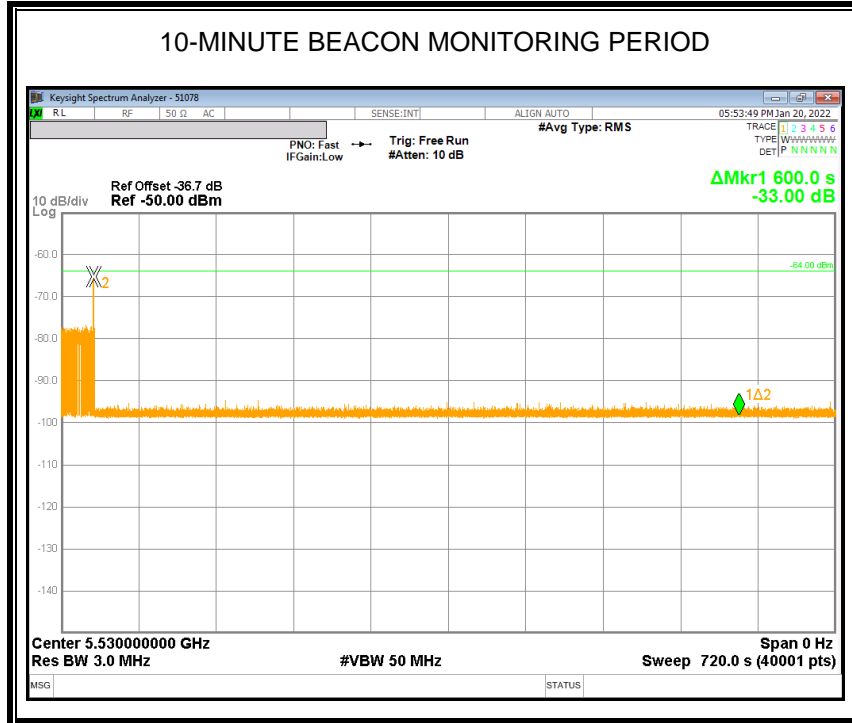

15. SPOT-CHECK TEST RESULT

BANDEDGE (WORST CASE: 802.11n HT40 / 5190 MHz)

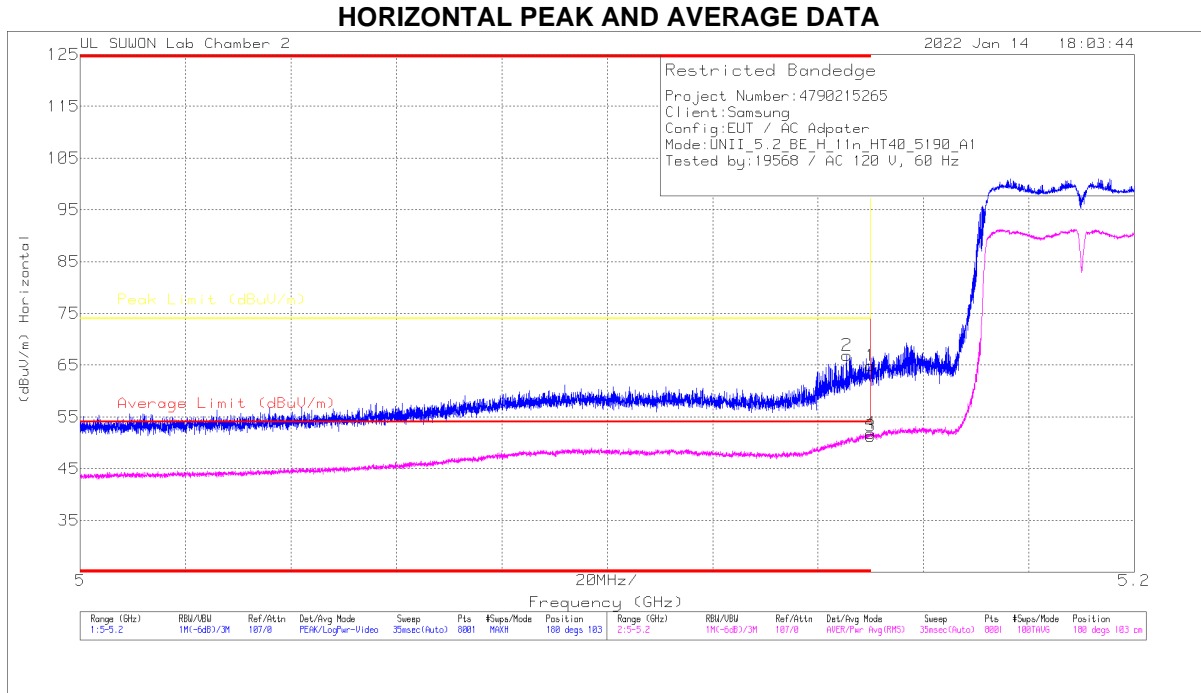

Trace Markers

Marker	Frequency (GHz)	Meter Reading (dBuV)	Det	3117_00168724	10dB_ATT[dB]	DC Corr (dB)	Corrected Reading (dBuV/m)	Average Limit (dBuV/m)	Margin (dB)	Peak Limit (dBuV/m)	PK Margin (dB)	Azimuth (Degs)	Height (cm)	Polarity
1	* 5.15	49.5	Pk	34.4	-18	0	54.9	-	-	74	-9.1	180	103	H
2	* 5.14548	50.49	Pk	34.4	-18	0	66.89	-	-	74	-7.11	180	103	H
3	* 5.15	34.71	RMS	34.4	-18	.18	51.29	54	-2.71	-	-	180	103	H
4	* 5.14993	35.27	RMS	34.4	-18	.18	51.85	54	-2.15	-	-	180	103	H

* - indicates frequency in CFR47 Pt 15 / IC RSS-Restricted Band
 PK - Peak detector
 RMS - RMS detection

HARMONICS AND SPURIOUS EMISSIONS(WORST CASE: 802.11a / 5180 MHz)
5180 MHz HORIZONTAL

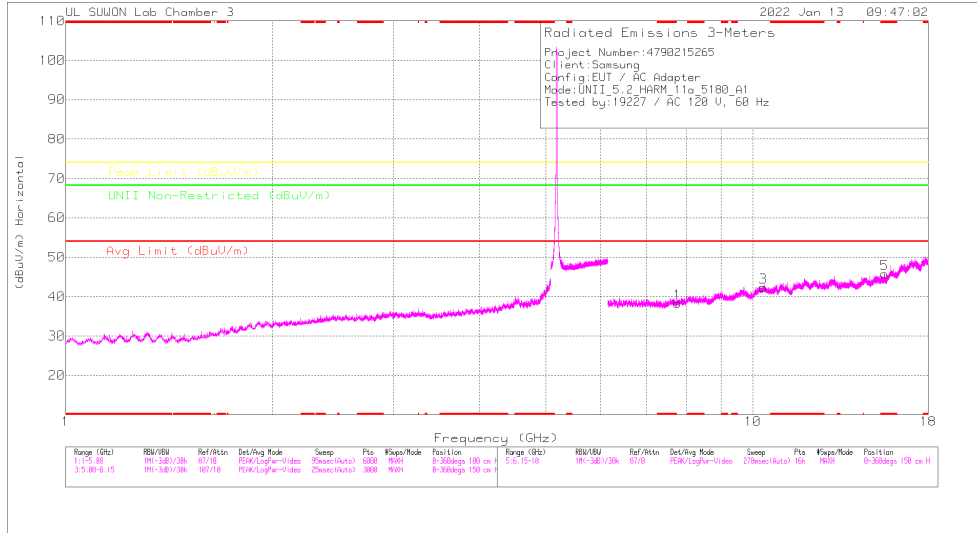

5180 MHz VERTICAL

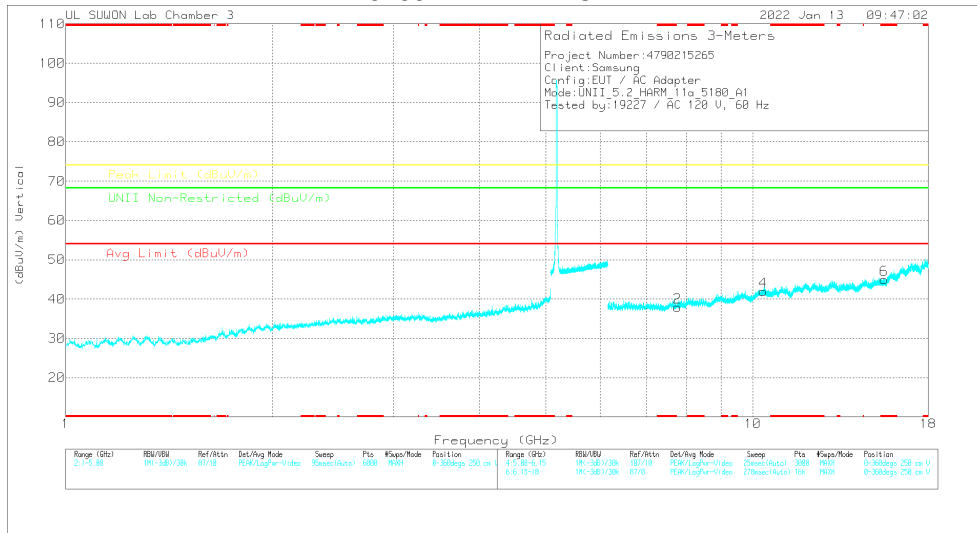

Note: Emission was scanned up to 40GHz; No emissions were detected above the noise floor which was at least 20dB below the specification limit.

Radiated Emissions

Frequency (GHz)	Meter Reading (dBuV)	Det	317...0021867	6GHz_HPSdB	DC Corr (dB)	Corrected Reading (dBuV/m)	Avg Line (dBuV/m)	Margin (dB)	Peak Limit (dBuV/m)	Margin (dB)	UNII Non-Restricted (dBuV/m)	Margin (dB)	Asimuth (Degs)	Height (cm)	Polarity
7.76398	37.64	PK-U	36.3	-25	0	48.94	-	-	-	-	68.2	-19.26	360	100	H
7.77579	37.08	PK-U	36.3	-24.9	0	48.48	-	-	-	-	68.2	-19.72	360	100	V
10.35028	35.57	PK-U	38.1	-21.3	0	52.37	-	-	-	-	68.2	-15.83	360	100	H
10.36038	34.92	PK-U	38.1	-21.3	0	51.72	-	-	-	-	68.2	-16.48	360	100	V
* 15.54119	36.22	PK-U	40.2	-21.9	0	54.52	-	-	74	-19.48	-	-	360	100	H
* 15.53322	35.61	PK-U	40.2	-22	0	53.81	-	-	74	-20.19	-	-	360	100	V

* - indicates frequency in CFR47 Pt 15 / IC RSS-Restricted Band
 PK-U - U-NII: Maximum Peak

BANDEDGE (WORST CASE: 802.11n HT40 / 5310 MHz)

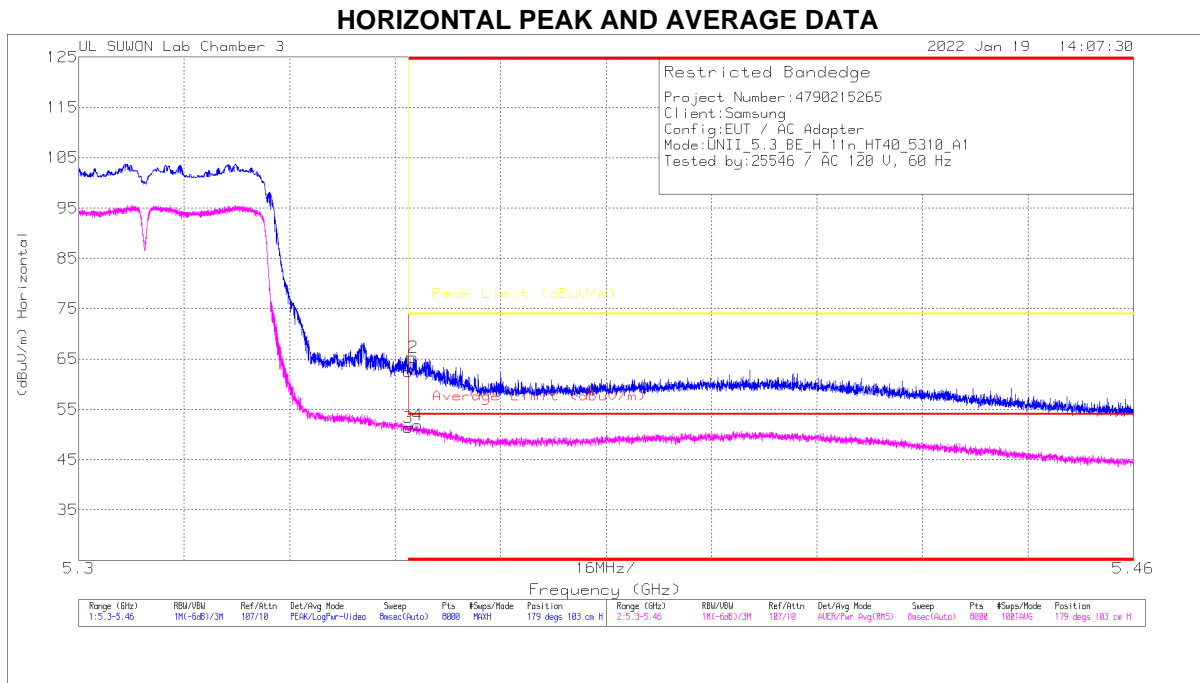

Trace Markers

Marker	Frequency (GHz)	Meter Reading (dBuV)	Det	3117_00218957	10dB_ATT[dB]	DC Cor (dB)	Corrected Reading (dBuV/m)	Average Limit (dBuV/m)	Margin (dB)	Peak Limit (dBuV/m)	PK Margin (dB)	Azimuth (Degs)	Height (cm)	Polarity
1	* 5.35001	48.1	Pk	35.1	-20.7	0	62.5	-	-	74	-11.5	179	103	H
2	* 5.35073	50.94	Pk	35.1	-20.7	0	65.34	-	-	74	-8.66	179	103	H
3	* 5.35001	36.82	RMS	35.1	-20.7	.18	51.4	54	-2.6	-	-	179	103	H
4	* 5.35145	37.43	RMS	35.1	-20.8	.18	51.91	54	-2.09	-	-	179	103	H

* - indicates frequency in CFR47 Pt 15 / IC RSS-Restricted Band
 Pk - Peak detector
 RMS - RMS detection

HARMONICS AND SPURIOUS EMISSIONS(WORST CASE: 802.11a / 5300 MHz)
5300 MHz HORIZONTAL

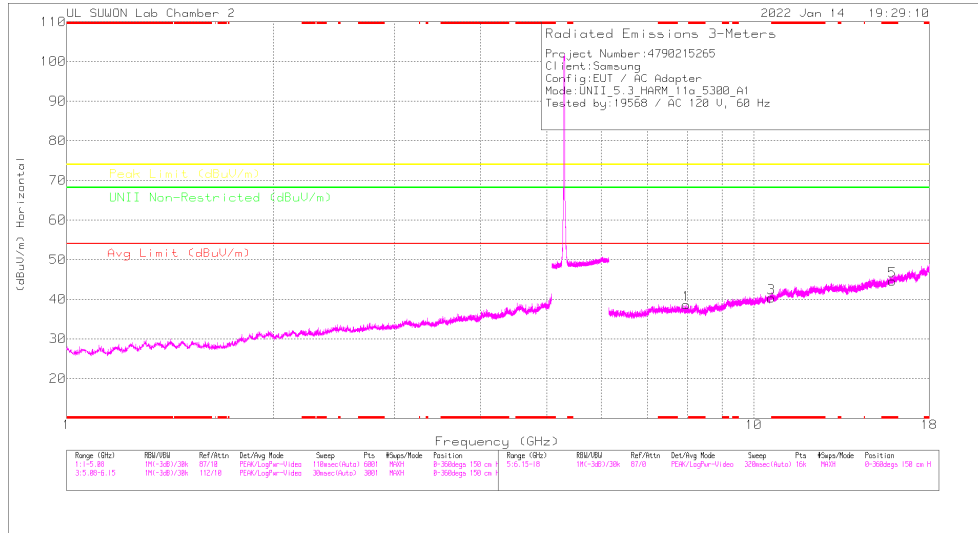

5300 MHz VERTICAL

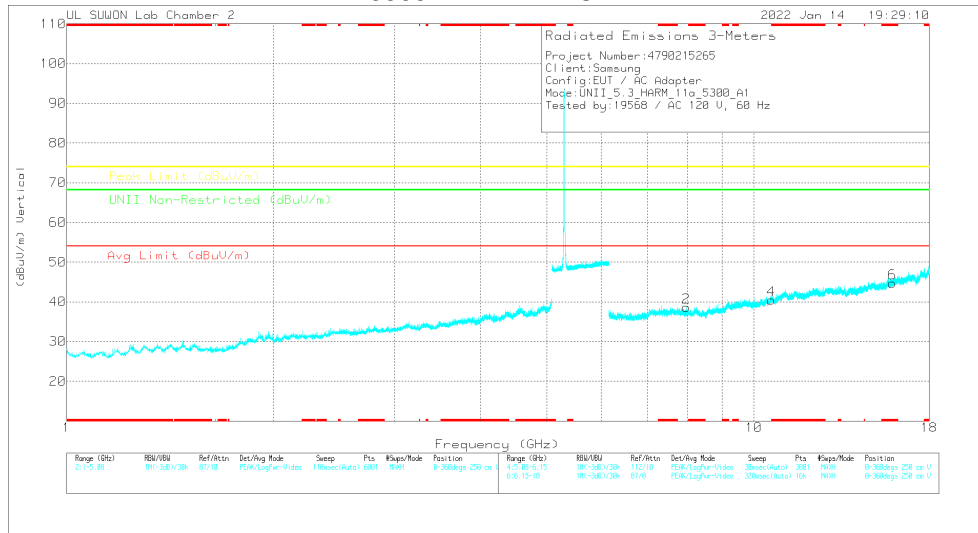

Note: Emission was scanned up to 40GHz; No emissions were detected above the noise floor which was at least 20dB below the specification limit.

Radiated Emissions

Frequency (GHz)	Mask Reading (dBµV)	Det	3117_00168724	(GHz_HF)(dB)	DC Corr (dB)	Corrected Reading (dBµV/m)	Avg Limit (dBµV/m)	Margin (dB)	Peak Limit (dBµV/m)	Margin (dB)	UNII Non-Restricted (dBµV/m)	Margin (dB)	Altitude (Degs)	Height (cm)	Polarity
10.59979	32.96	PK-U		37.9	-19.5	0	51.36	-	-	-	68.2	-16.84	0	100	H

* - indicates frequency in CFR47 Pt 15 / IC RSS-Restricted Band
 PK-U - U-NII: Maximum Peak

BANDEDGE (WORST CASE: 802.11ac VHT80 / 5530 MHz)

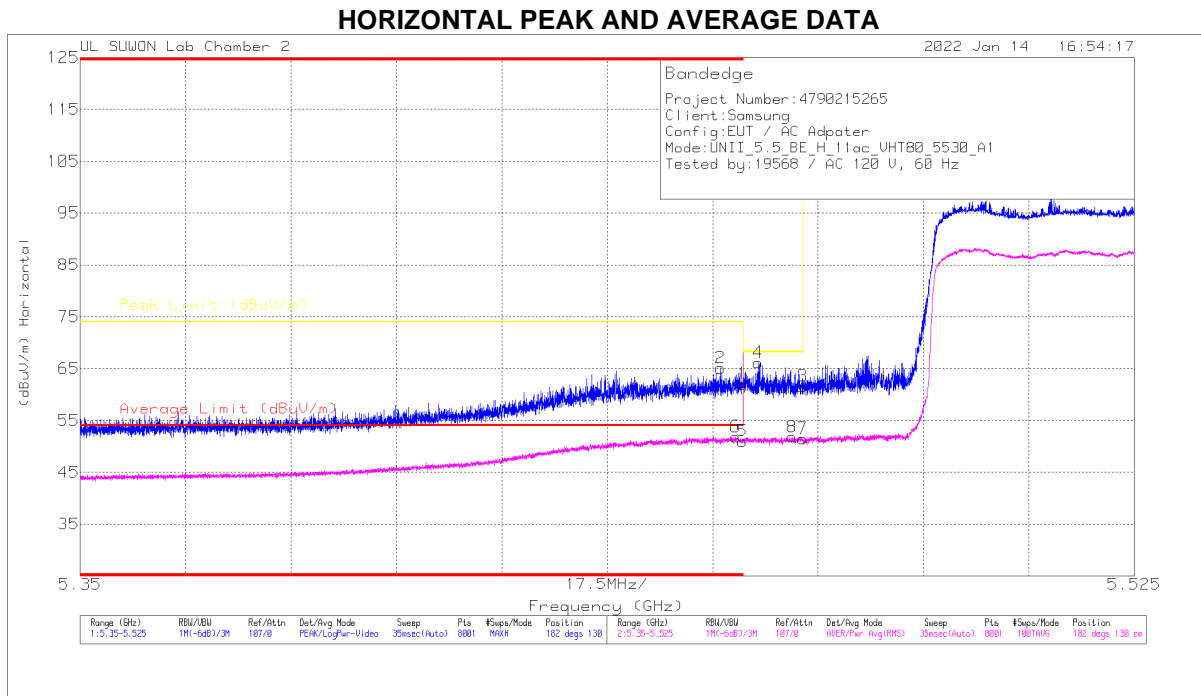

Trace Markers

Marker	Frequency (GHz)	Meter Reading (dBuV)	Det	3117_00168724	10dB_ATT[dB]	DC Cor (dB)	Corrected Reading (dBuV/m)	Average Limit (dBuV/m)	Margin (dB)	Peak Limit (dBuV/m)	PK Margin (dB)	Azimuth (Degs)	Height (cm)	Polarity
1	* 5.45999	45.41	PK		-18	0	62.01	-	-	74	-11.99	182	130	H
2	* 5.45831	48.62	PK		-18.1	0	65.12	-	-	74	-8.88	182	130	H
3	5.46998	44.97	PK		-18	0	61.57	-	-	68.2	-6.63	182	130	H
4	5.46255	49.65	PK		-18.1	0	66.15	-	-	68.2	-2.05	182	130	H
5	* 5.45999	34.17	RMS		-18	25	51.02	54	-2.98	-	-	182	130	H
6	* 5.45878	35.1	RMS		-18.1	25	51.85	54	-2.15	-	-	182	130	H
7	5.46998	34.61	RMS		-18	25	51.46	-	-	-	-	182	130	H
8	5.46817	34.95	RMS		-18	25	51.8	-	-	-	-	182	130	H

* - indicates frequency in CFR47 Pt 15 / IC RSS-Restricted Band
 PK - Peak detector
 RMS - RMS detection

HARMONICS AND SPURIOUS EMISSIONS(WORST CASE: 802.11a / 5720 MHz)
5720 MHz HORIZONTAL

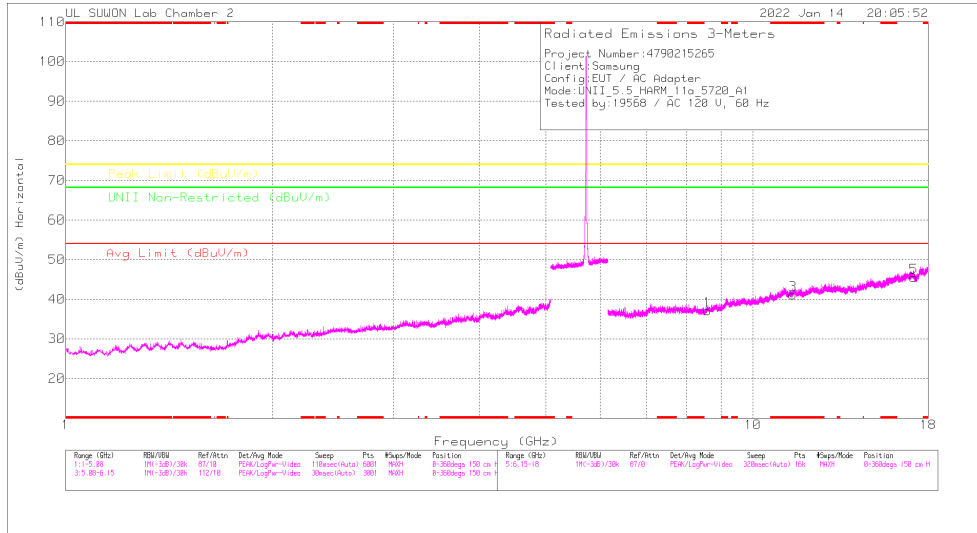

5720 MHz VERTICAL

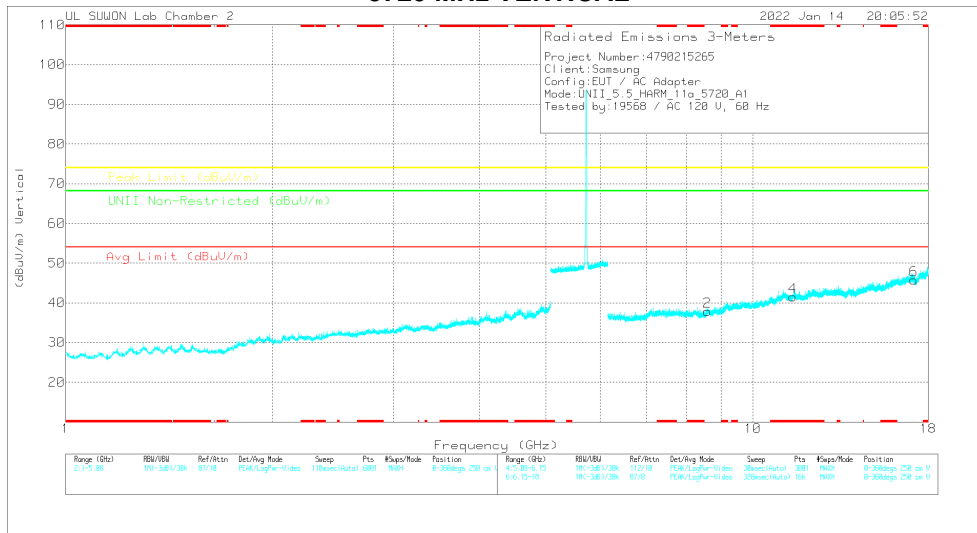

Note: Emission was scanned up to 40GHz; No emissions were detected above the noise floor which was at least 20dB below the specification limit.

Radiated Emissions

Frequency (GHz)	Meas Reading (dBuV)	Det	3117_00168724	6GHz_HPB(B)	DC Corr (dB)	Corrected Reading (dBuV)	Avg Limit (dBV/m)	Margin (dB)	Peak Limit (dBV/m)	Margin (dB)	UNII Non-Restricted (dBV/m)	Margin (dB)	Azimuth (Degs)	Height (m)	Polarity
17.1600	34.04	PK-U	40.9	-18.2	0	56.74	-	-	-	-	68.2	-11.46	0	100	H

* - indicates frequency in CFR47 Pt 15 / IC RSS-Restricted Band
 PK-U - U-NII: Maximum Peak

BANDEDGE (WORST CASE: 802.11ac VHT80 / 5775 MHz)

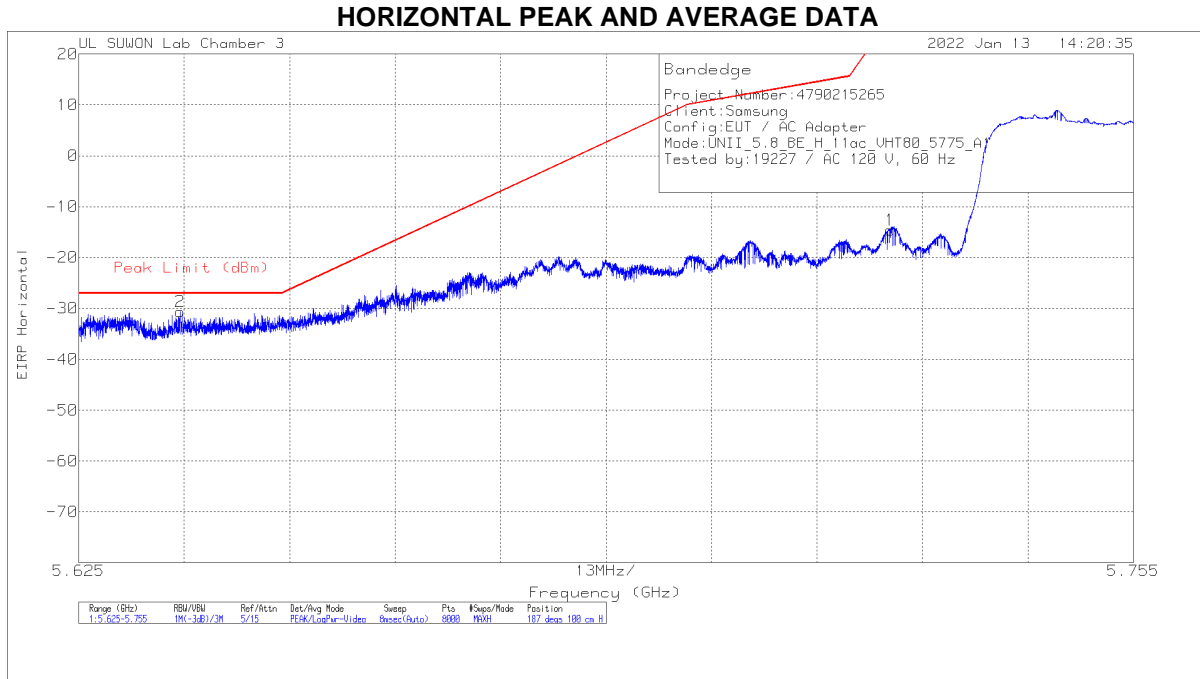

Trace Markers

Marker	Frequency (GHz)	Meter Reading (dBm)	Det	3117_00218957	10dB_ATT[dB]	Conversion Factor (dB)	DC Corr (dB)	Corrected Reading EIRP	Peak Limit (dBm)	PK Margin (dB)	Azimuth (Degs)	Height (cm)	Polarity
1	5.725	-41.96	Pk	35.6	-20	11.8	0	-14.56	27	-41.56	187	100	H
2	5.63748	-57.61	Pk	35.5	-20.3	11.8	0	-30.61	-27	-3.61	187	100	H

Pk - Peak detector

HARMONICS AND SPURIOUS EMISSIONS(WORST CASE: 802.11a / 5745 MHz)
5745 MHz HORIZONTAL

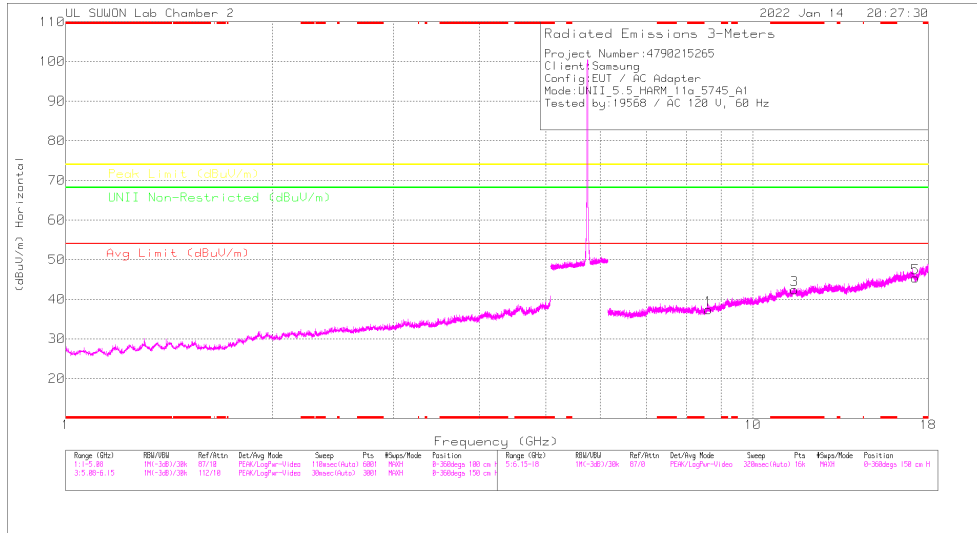

5745 MHz VERTICAL

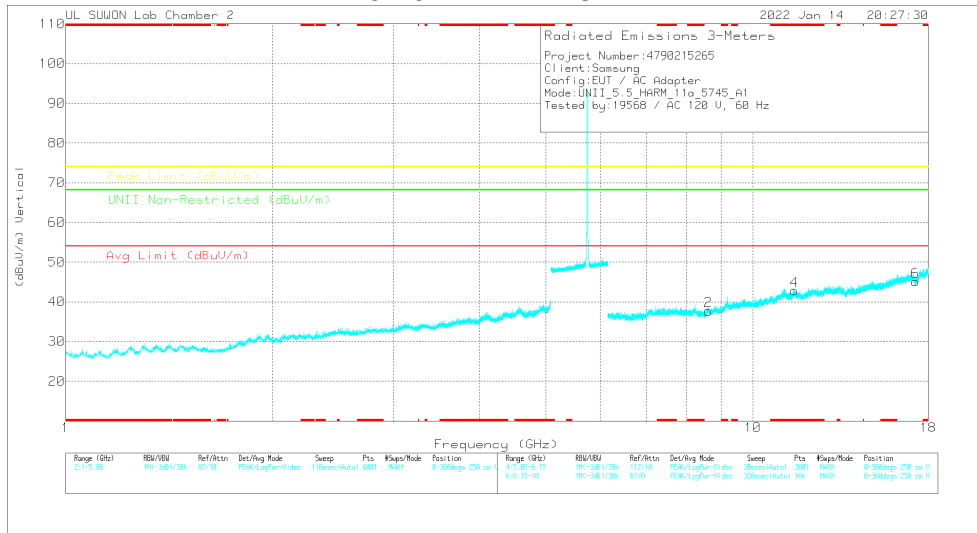

Note: Emission was scanned up to 40GHz; No emissions were detected above the noise floor which was at least 20dB below the specification limit.

Radiated Emissions

Frequency (GHz)	Mask Reading (dBuV)	Det	3117_00168724	(GHz_HF)(dB)	DC Corr (dB)	Corrected Reading (dBuV/m)	Avg Limit (dBV/m)	Margin (dB)	Peak Limit (dBuV/m)	Margin (dB)	UNII Non-Restricted (dBuV/m)	Margin (dB)	Altitude (Degs)	Height (cm)	Polarity
17.23425	33.77	PK-U	40.9	-18.7	0	55.97	-	-	-	-	68.2	-12.23	0	100	H

* - indicates frequency in CFR47 Pt 15 / IC RSS-Restricted Band
 PK-U - U-NII: Maximum Peak

END OF TEST REPORT