

EMC TEST REPORT

Project No.	LBE20210912	Issue No.	0
Applicant	Name of organization	Samsung Electronics Co., Ltd.	
	Address	(Maetan-dong) 129, Samsung-ro, Yeongtong-gu, Suwon-si, Gyeonggi-do, 16677, Korea	
	Date of receipt	December 27, 2021	
EUT	Type of device	<input checked="" type="checkbox"/> All other receivers subject to Part 15 <input checked="" type="checkbox"/> Class B personal computers and peripherals <input checked="" type="checkbox"/> Other Class B digital devices and peripherals <input checked="" type="checkbox"/> FM Broadcast Receiver	
	Equipment authorization	<input checked="" type="checkbox"/> Certification <input type="checkbox"/> Supplier's Declaration of Conformity	
	FCC ID	A3LSMA135M	
	Kind of product	Mobile Phone	
	Model No.	SM-A135M/DS	
	Variant Model No.	Refer to clause 4.6	
	Manufacturer	Samsung Electronics Vietnam Thai Nguyen Co., Ltd. Yen Binh Industrial Zone Pho Ten Dist., Thai Nguyen Province, Vietnam	
Applied Standards		47 CFR Part 15, Subpart B, Class B / ANSI C63.4-2014	
Test Period		January 12, 2022 ~ January 27, 2022	
Issue date		January 28, 2022	

Test result : Complied

The equipment under test has found to be compliant with the applied standards.
(Refer to the attached test result for more detail.)

Tested by : Eun-Kyung Oh



Reviewed by : Chang-Eun Park



The test results in this report only apply to the tested sample. This report must not be reproduced, except in full, without written permission from Global CS center. * Not KOLAS report

Samsung Electronics Co., Ltd., Global CS Center
(Maetan dong) 129, Samsung-ro, Yeongtong-Gu, Suwon-Si, Gyeonggi-Do 16677, Korea

Table of Contents

1. Report Information	3
1.1 Revision history	3
2. Summary of test results	3
2.1 Emission.....	3
3. General Information	3
3.1 Test facility	3
4. Test Setup configuration	4
4.1 Test Peripherals	4
4.2 EUT operating mode	5
4.3 Details of Sampling.....	5
4.4 Used cable description	6
4.5 Test arrangement	7
4.6 EUT Description.....	10
4.7 EUT Frequencies	10
4.8 Test configuration and condition	11
4.9 Measurement uncertainty	11
5. Results of individual test	12
5.1 Conducted Emission	12
5.2 Radiated Emission.....	18

1. Report Information

1.1 Revision history

No.	Date of Issue	Revised detailed information
Issue 0	January 28, 2022	There are no revisions and this version is basic test report.

※ Remark

Only compliance with Part 15B (Section 15.107 Conducted limits) requirements for the receiver part of the licensed transmitter (equipment code CXX) is covered by this report.

2. Summary of test results

2.1 Emission

The EUT has been tested according to the following specifications:

Applied	Test type	Applied standard	Result
■	Conducted Emission (Mains port)	47 CFR Part 15 Subpart B / ANSI C63.4-2014 (Class B)	Complied
■	Radiated Emission		Complied

3. General Information

3.1 Test facility

The Global CS Center is located on Samsung Electronics Co., Ltd. at (Maetan-dong) 129, Samsung-ro, Yeongtong-gu, Suwon-si, Gyeonggi-do, 16677, Korea.

All testing are performed in Semi-anechoic chambers conforming to the site attenuation characteristics defined by ANSI C63.4, CISPR 32, CISPR 16-1-4 and Shielded rooms.

And all antennas are properly calibrated using ANSI C63.5:2017.

The Global CS Center is an ISO/IEC 17025 accredited testing laboratory by the National Radio Research Agency with designation No. KR0004. for EMC testing.

4. Test Setup configuration

4.1 Test Peripherals

The cables used for these peripherals are either permanently attached by the peripheral manufacturer or coupled with an assigned cable as defined below.

The following is a listing of the EUT and peripherals utilized during the performance of EMC test:

Description	Model No.	Serial No.	Manufacturer / Trademark	FCC ID
Mobile Phone	SM-A135M/DS	-	SAMSUNG	A3LSMA135M
Battery	EB-BA217ABY	-	SDI	-
Headset	EHS61ASFWE	-	FOSTER	-
Data Cable	EP-DR140	-	RFTECH	-
Laptop Computer	Latitude5580	1WYRYM2	Dell	DoC
Laptop Computer	Latitude5580	D3HRYM2	Dell	DoC
Laptop AC Adapter	LA65NM130	5DEA	Dell	DoC
Laptop AC Adapter	LA65NM130	5B3C	Dell	DoC
Mouse	AA-SM7PCPB	CN57BA5903634AD V8JJCD4371	SAMSUNG	DoC
Mouse	SMH-210UB	TAKGA05788 Z	SAMSUNG	DoC
Router	DIR-806A	RF0F1D8018454	D-Link	DoC
Router	DIR-806A	RF0F1D8011504	D-Link	DoC
Travel Adapter	EP-TA200	R37RC7V0934HM3	HAEM	-
Micro SD Card	64GB	-	SAMSUNG	-

4.2 EUT operating mode

To achieve compliance applied standard specification including CXX, JAB and JBP requirement, the following mode(s) were made during compliance testing:

4.2.1 Conducted Emission

No.	Operating mode
1	Camera (Rear) + Charging (w/TA) + Cellular receiver (LTE FDD26 Center Frequency) + FM(low ch.)
2	Camera (Front) + Charging (w/TA) + FM(mid ch.)
3	Charging (w/TA) + FM(high ch.)
4	Video + Audio playback from internal memory + Charging (w/TA)
5	USB data communication with PC (from external memory)

4.2.2 Radiated Emission

No.	Operating mode
1	Camera (Rear) + Charging (w/TA) + FM(low ch.)
2	Camera (Front) + FM(mid ch.)
3	FM(high ch.)
4	Video + Audio playback from internal memory
5	USB data communication with PC (from external memory)

4.3 Details of Sampling

Customer selected, single unit.

4.4 Used cable description

The EUT is configured, installed, arranged and operated in a manner consistent with typical applications. Interface cables/loads/devices are connected to at least one of each type of interface port of the EUT, and where practical, each cable shall be terminated in a device typical of actual usage. The type(s) of interconnecting cables to be used and the interface port (of the EUT) to which these were connected:

Connected cable	Length [m]	Shielded [Y/N]	Note
Data Cable	0.8	Y	From EUT to Laptop Computer or Travel Adapter
Headset	1.6	N	For EUT
Power	1.8	N	From Laptop Computer to AC Adapter
Power	1.5	N	For Laptop AC Adapter
LAN	1.5	N	From Laptop Computer to Router
USB	0.8	Y	From Laptop Computer to Router for DC Power
USB	1.8	Y	From Laptop Computer to Mouse

4.5 Test arrangement

4.5.1 Conducted Emission

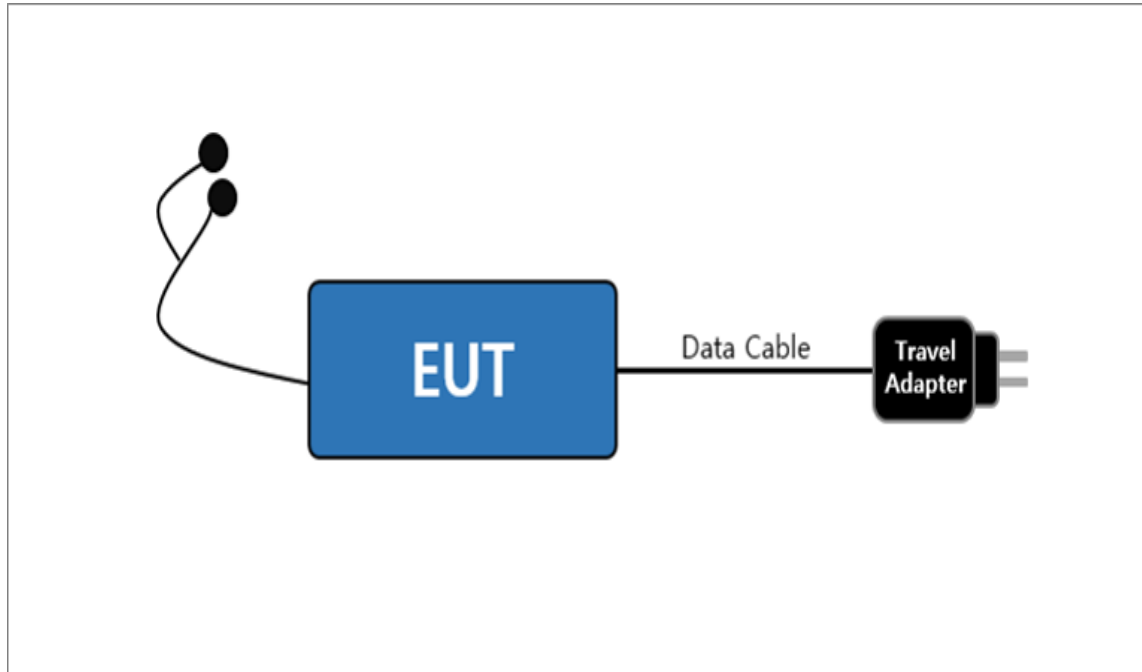

[Mode 1 – 4]

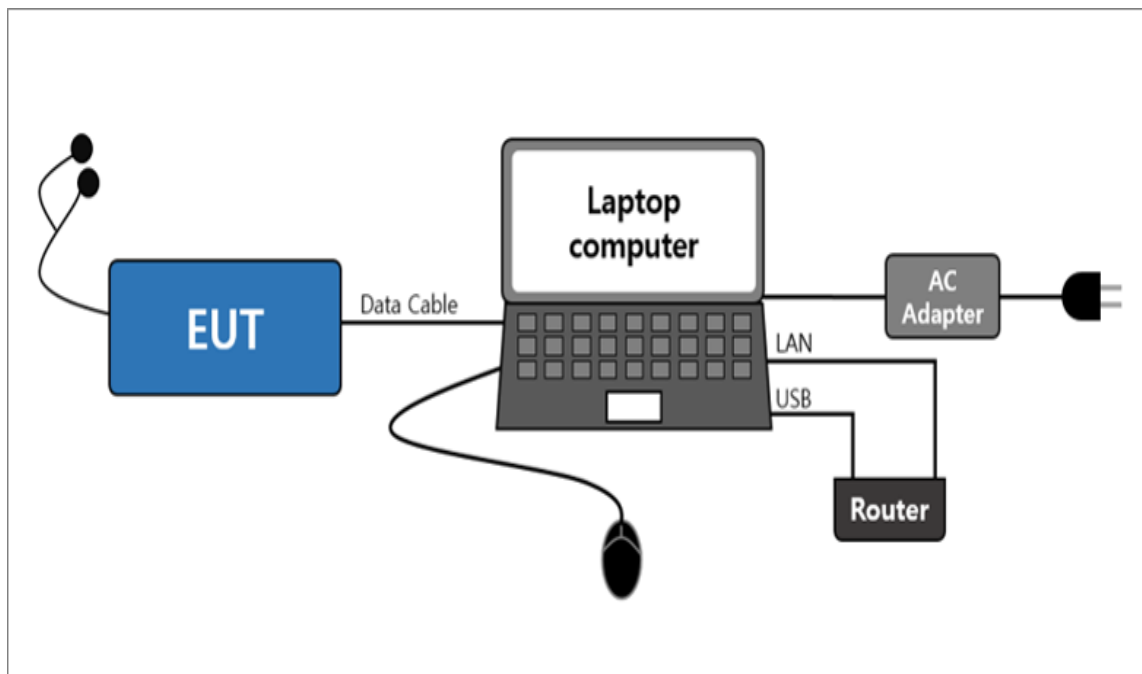

[Mode 5]

4.5.2 Radiated Emission

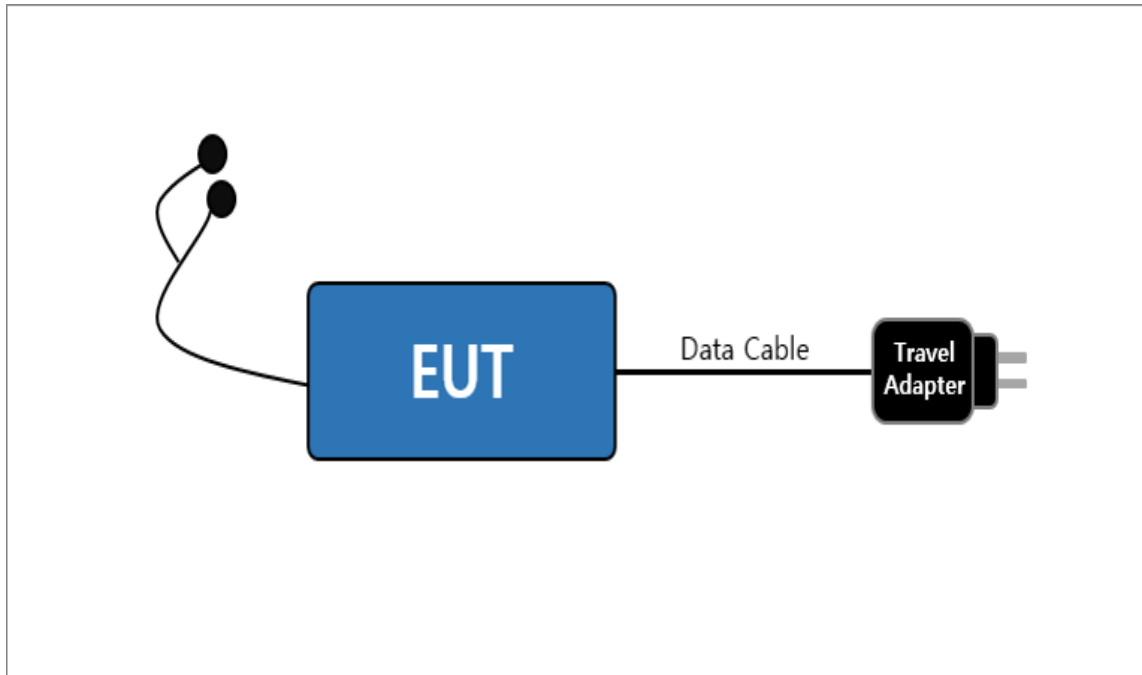

[Mode 1]

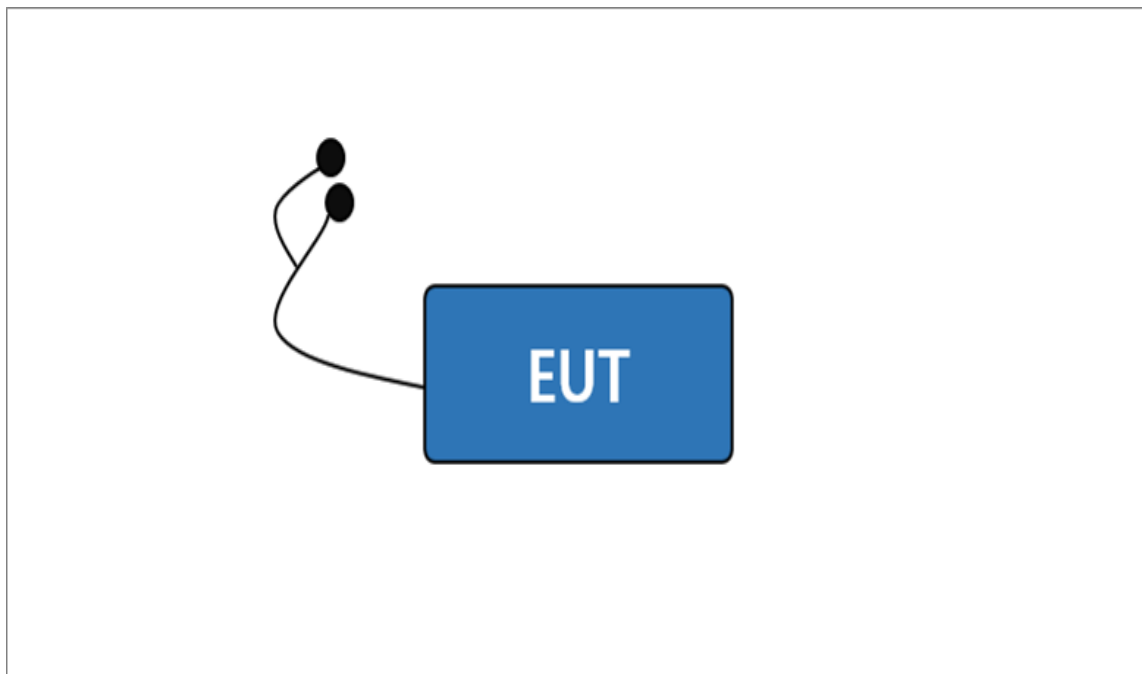

[Mode 2 – 4]

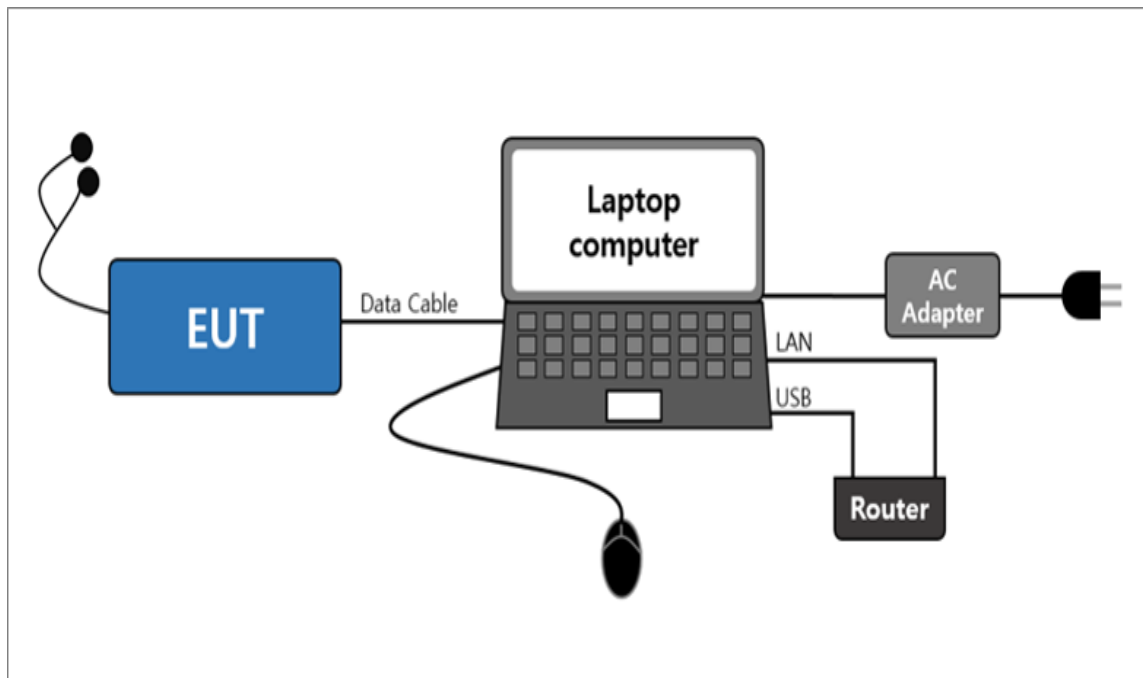

[Mode 5]

4.6 EUT Description

The EUT is a bar type mobile phone which can operate on GSM850/900/1800/1900, WCDMA FDD 1/2/4/5/8, LTE FDD 1/2/3/4/5/7/8/12/13/17/26/28/66, LTE TDD38/40/41 and incorporates a Bluetooth, Wi-Fi (802.11 b/g/n/a/ac), Camera, Audio, Video, FM Radio and GNSS.

4.6.1 The variant models

- SM-A135M

4.7 EUT Frequencies

The highest frequencies (Generated and used)	Frequency [MHz]
Wi-Fi	5 825

4.8 Test configuration and condition

The system was configured for testing in a typical fashion that a customer would normally use. Cables were attached to each of the available I/O Ports. Where applicable, peripherals were attached to the I/O cables.

All the external I/O ports are exercised, as well as internal and the external SD card(if available), by writing and reading arbitrary data or charging with TA.

The EUT was investigated in three orientations and the worst case orientation is reported.

RX mode(850MHz) testing for AC conducted emission test was performed with the LTE FDD26 RX Test mode at center frequency. All licensed communication (850MHz) RX mode, GSM/WCDMA /LTE, test results are not significantly different.

The FM radio mode radiated testing was performed with the Low/Mid/High channel.

The video and audio were repetitively played with the earphone connected.

The camera of the EUT was operated continuously.

Power source for the EUT operating was supplied by CVCF made by the Pacific Corp.

- Test Voltage : AC 120 V, 60 Hz

4.9 Measurement uncertainty

Where relevant, the following measurement uncertainty levels have been estimated for tests performed on the apparatus : (According to CISPR 16-4-2 and UKAS M3003)

Test type		Measurement uncertainty (C.L. approximately 95 %, $k = 2$)
Conducted Emission	AC Mains	2.83 dB
Radiated Emission (Below 1 GHz)	Horizontal	5.03 dB
	Vertical	6.13 dB
Radiated Emission (Above 1 GHz)	Horizontal	4.99 dB
	Vertical	4.99 dB

* Remark

- 1) The values for uncertainty of conducted and radiated emissions are less than the Corresponding values of Ucispr given in CISPR 16-4-2. Therefore no adjustment of measurement results is necessary when comparing them with the relevant limits.

5. Results of individual test

5.1 Conducted Emission

The EUT is connected to a LISN via travel adapter. If the EUT is connected to the Laptop Computer USB port, the Laptop AC adapter is connected to a LISN.

Both conducted lines are measured in Quasi-Peak and CISPR-Average mode, including the worst-case data points for each tested configuration. The EUT measured in accordance with the methods described in standards.

Limits for Conducted emission at the mains ports of Class B

Frequency range Limits [MHz]	Resolution Bandwidth [kHz]	Limits [dB(μ V)]	
		Quasi-peak	Average
0.15 to 0.50	9	66 to 56	56 to 46
0.50 to 5	9	56	46
5 to 30	9	60	50

NOTE 1 The lower limit shall apply at the transition frequency.
NOTE 2 The limit decreases linearly with the logarithm of the frequency in the range 0.15 MHz to 0.50 MHz.

5.1.1 Test instrumentation

EMC No.	Test Instrument	Model name	Manufacturer	Serial No.	Next Calibration	
					Date	Interval (Month)
E5I-006	LTE Communicator	CMW500	R&S	132728	2022-04-06	12
E5I-002	Universal Radio Communicator	CMU200	R&S	100612	2022-08-12	12
E5I-127	Two-Line V-Network	ENV216	R&S	102061	2023-01-17	12
E5I-016	EMI Test Receiver	ESU8	R&S	100482	2022-06-03	12
-	Test software	EMC32	R&S	Ver 10.60.20	-	-

5.1.2 Temperature and humidity condition

Test date	2022-01-27	Test engineer	Eun-Kyung Oh
Climate condition	Ambient temperature	(26.6 \pm 0.5) °C	Limit (15.0 to 35.0) °C
	Relative humidity	(34.6 \pm 0.5) % R.H.	Limit (25.0 to 75.0) % R.H.
	Atmospheric pressure	(101.4 \pm 0.5) kPa	Limit (86.0 to 106.0) kPa
Test place	Shield Room (SR8)		

5.1.3 Test Results

□ Operating Mode 1: AC Mains

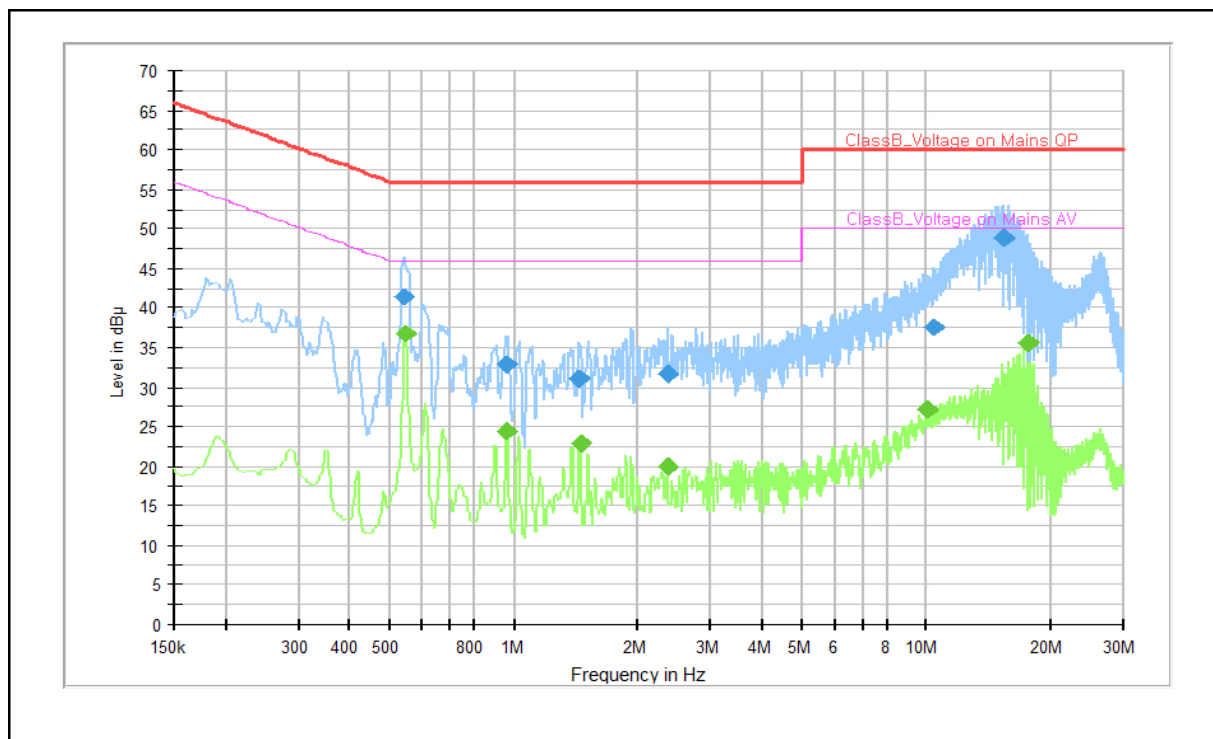

Note 1) Two graphs measured for both Live(L1) and Neutral(N) of the LISN are combined into one graph.

QP / CAV final measurement results table:

Frequency (MHz)	QP (dBμV)	CAV (dBμV)	Limit (dBμV)	Margin (dB)	Line	Corr. (dB)
0.539	41.4	---	56.0	14.6	N	10.1
0.546	---	36.7	46.0	9.3	L1	10.2
0.962	32.9	---	56.0	23.1	L1	10.0
0.965	---	24.4	46.0	21.6	L1	10.0
1.446	31.0	---	56.0	25.0	N	9.9
1.451	---	22.9	46.0	23.1	N	9.9
2.353	---	19.9	46.0	26.1	N	9.9
2.357	31.6	---	56.0	24.4	N	9.9
10.088	---	27.2	50.0	22.8	N	10.2
10.379	37.5	---	60.0	22.5	N	10.2
15.401	48.9	---	60.0	11.1	N	10.4
17.752	---	35.6	50.0	14.4	N	10.5

Note 2) Level (QP and/or CAV) = Meter Reading (QP and/or CAV) + Corr. (LISN Insertion Loss + Cable Loss)
 Margin (QP and/or CAV) = Limit – Level (QP and/or CAV)
 QP = Quasi-Peak, CAV = CISPR-Average, Corr. = Correction Factor

□ **Operating Mode 2: AC Mains**

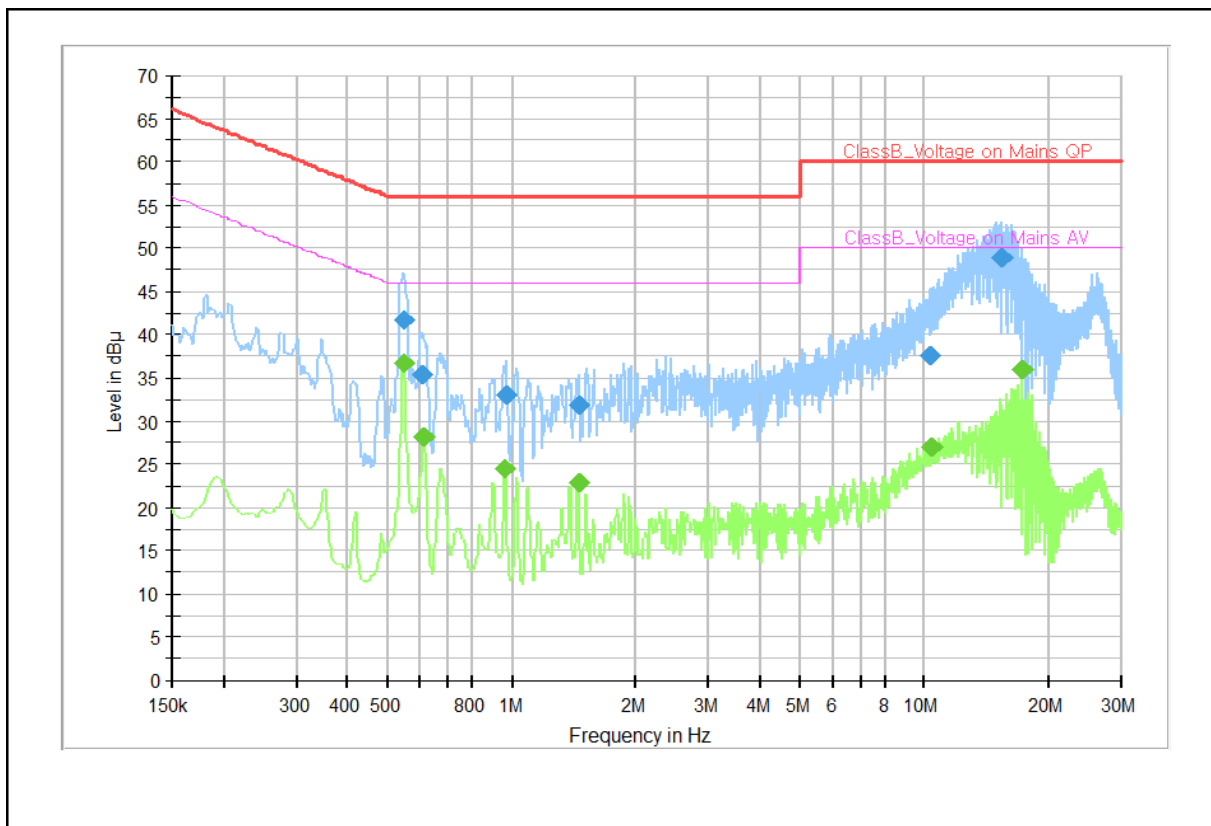

Note 1) Two graphs measured for both Live(L1) and Neutral(N) of the LISN are combined into one graph.

QP / CAV final measurement results table:

Frequency (MHz)	QP (dBµV)	CAV (dBµV)	Limit (dBµV)	Margin (dB)	Line	Corr. (dB)
0.546	---	36.7	46.0	9.3	L1	10.2
0.548	41.7	---	56.0	14.3	N	10.1
0.602	35.5	---	56.0	20.5	N	10.1
0.611	---	28.1	46.0	17.9	N	10.1
0.965	---	24.4	46.0	21.6	L1	10.0
0.971	32.9	---	56.0	23.1	L1	10.0
1.451	31.8	---	56.0	24.2	N	9.9
1.451	---	22.9	46.0	23.1	N	9.9
10.322	37.5	---	60.0	22.5	N	10.2
10.383	---	27.0	50.0	23.0	N	10.2
15.405	48.8	---	60.0	11.2	N	10.4
17.273	---	35.9	50.0	14.1	N	10.5

Note 2) Level (QP and/or CAV) = Meter Reading (QP and/or CAV) + Corr. (LISN Insertion Loss + Cable Loss)
 Margin (QP and/or CAV) = Limit – Level (QP and/or CAV)
 QP = Quasi-Peak, CAV = CISPR-Average, Corr. = Correction Factor

□ **Operating Mode 3: AC Mains**

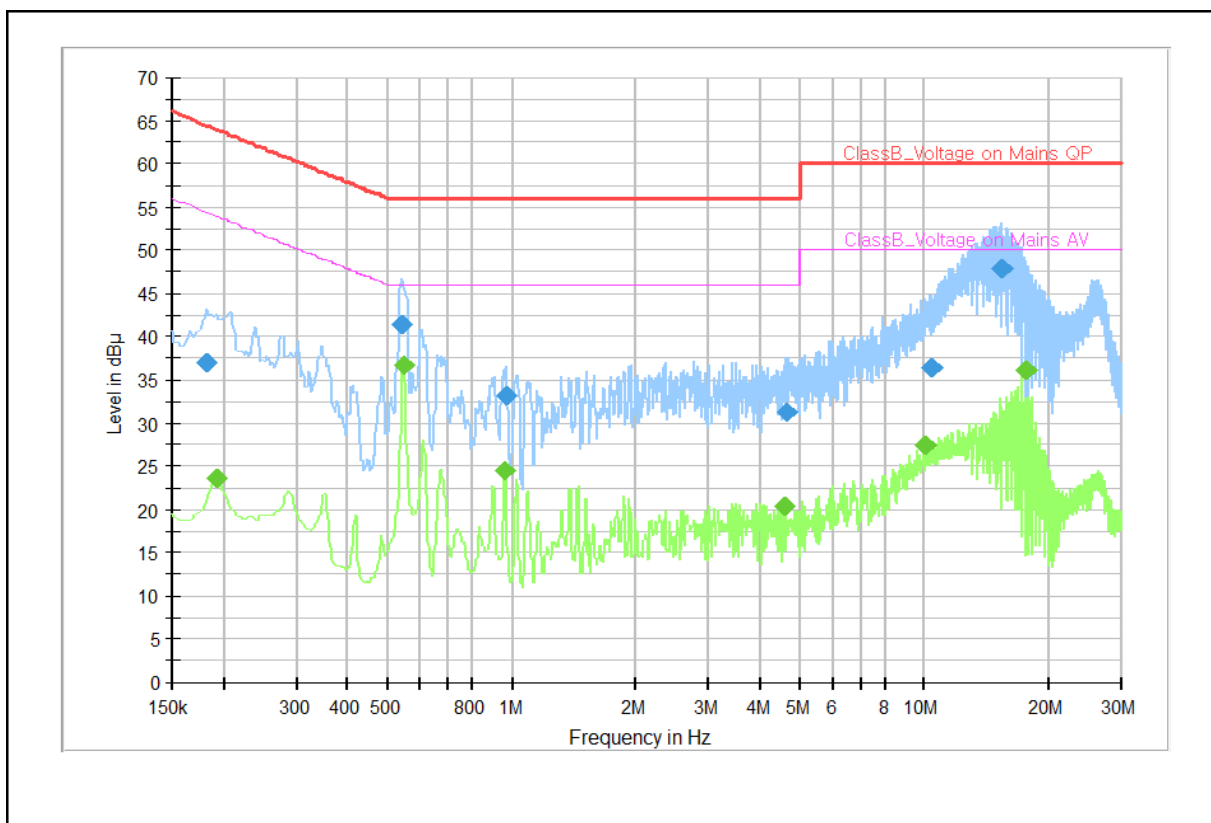

Note 1) Two graphs measured for both Live(L1) and Neutral(N) of the LISN are combined into one graph.

QP / CAV final measurement results table:

Frequency (MHz)	QP (dBµV)	CAV (dBµV)	Limit (dBµV)	Margin (dB)	Line	Corr. (dB)
0.182	36.9	---	64.4	27.5	L1	10.0
0.193	---	23.6	53.9	30.3	L1	10.0
0.539	41.5	---	56.0	14.5	N	10.1
0.546	---	36.7	46.0	9.3	L1	10.2
0.965	---	24.5	46.0	21.5	L1	10.0
0.967	33.3	---	56.0	22.7	L1	10.0
4.571	---	20.4	46.0	25.6	N	9.9
4.661	31.3	---	56.0	24.7	N	9.9
10.086	---	27.3	50.0	22.7	N	10.2
10.374	36.5	---	60.0	23.5	N	10.2
15.464	48.0	---	60.0	12.0	N	10.4
17.750	---	36.2	50.0	13.8	N	10.5

Note 2) Level (QP and/or CAV) = Meter Reading (QP and/or CAV) + Corr. (LISN Insertion Loss + Cable Loss)
 Margin (QP and/or CAV) = Limit – Level (QP and/or CAV)
 QP = Quasi-Peak, CAV = CISPR-Average, Corr. = Correction Factor

□ **Operating Mode 4: AC Mains**

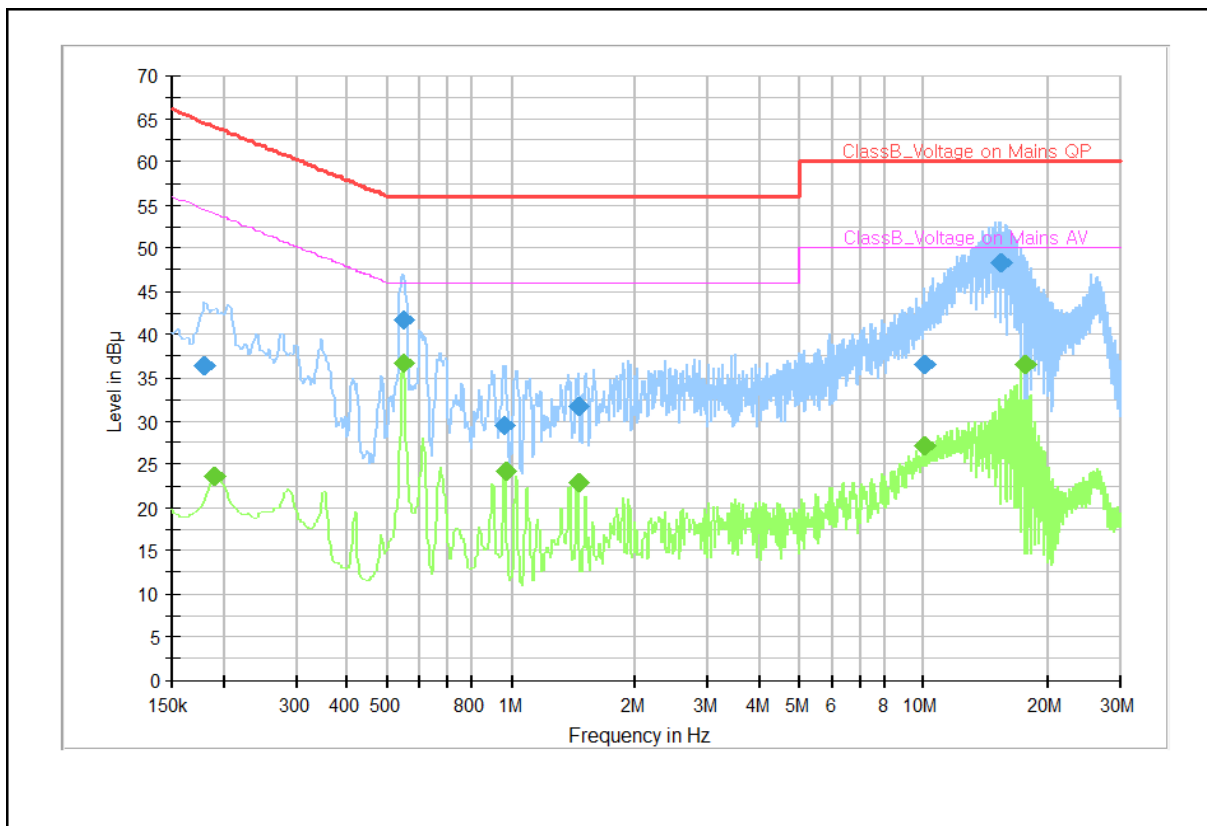

Note 1) Two graphs measured for both Live(L1) and Neutral(N) of the LISN are combined into one graph.

QP / CAV final measurement results table:

Frequency (MHz)	QP (dBμV)	CAV (dBμV)	Limit (dBμV)	Margin (dB)	Line	Corr. (dB)
0.179	36.5	---	64.5	28.1	L1	10.0
0.191	---	23.6	54.0	30.4	L1	10.0
0.546	---	36.7	46.0	9.3	L1	10.2
0.548	41.7	---	56.0	14.3	N	10.1
0.960	29.6	---	56.0	26.4	N	9.9
0.967	---	24.3	46.0	21.7	L1	10.0
1.451	31.7	---	56.0	24.3	N	9.9
1.451	---	22.8	46.0	23.2	N	9.9
10.091	---	27.2	50.0	22.8	N	10.2
10.118	36.6	---	60.0	23.4	N	10.2
15.401	48.3	---	60.0	11.7	N	10.4
17.754	---	36.5	50.0	13.5	N	10.5

Note 2) Level (QP and/or CAV) = Meter Reading (QP and/or CAV) + Corr. (LISN Insertion Loss + Cable Loss)
 Margin (QP and/or CAV) = Limit – Level (QP and/or CAV)
 QP = Quasi-Peak, CAV = CISPR-Average, Corr. = Correction Factor

□ **Operating Mode 5: AC Mains**

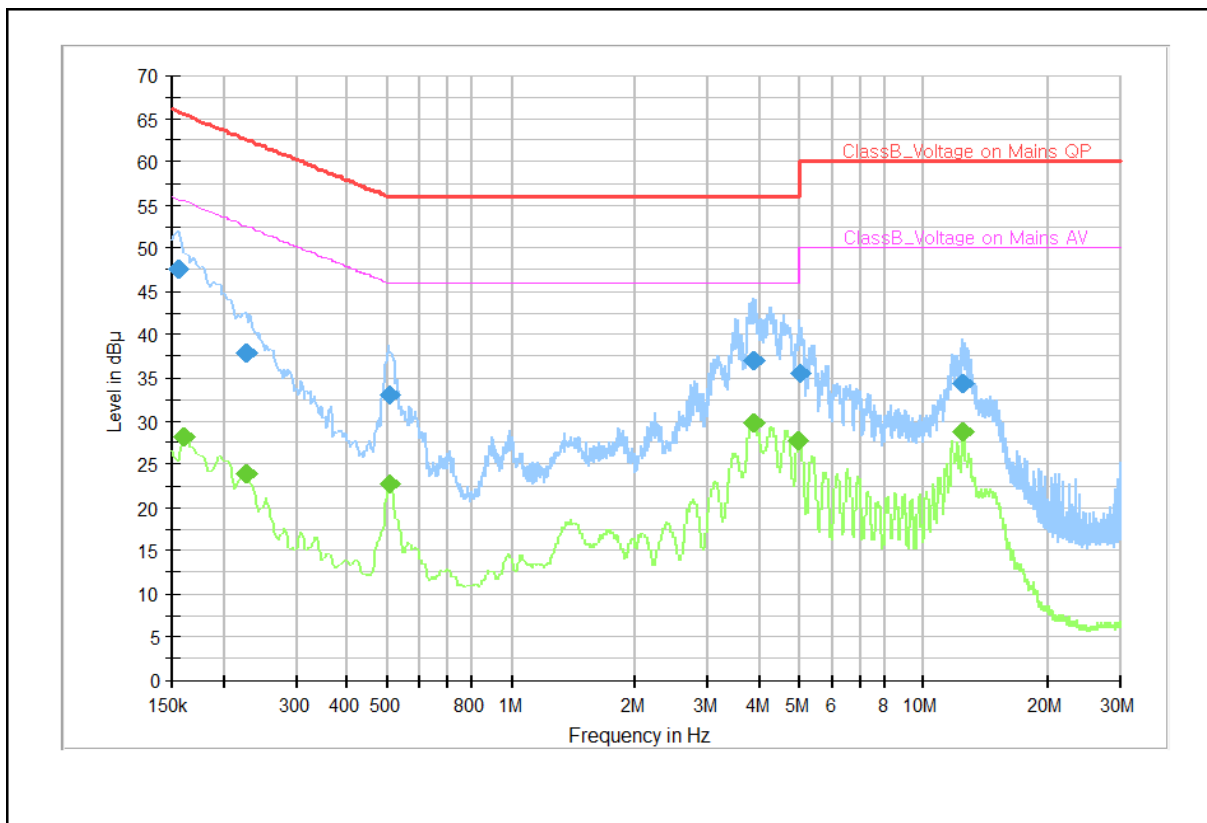

Note 1) Two graphs measured for both Live(L1) and Neutral(N) of the LISN are combined into one graph.

QP / CAV final measurement results table:

Frequency (MHz)	QP (dBµV)	CAV (dBµV)	Limit (dBµV)	Margin (dB)	Line	Corr. (dB)
0.155	47.5	---	65.8	18.2	L1	9.8
0.161	---	28.2	55.4	27.2	N	9.8
0.227	---	23.9	52.6	28.6	L1	9.8
0.227	37.8	---	62.6	24.7	L1	9.8
0.506	33.0	---	56.0	23.0	L1	10.1
0.508	---	22.6	46.0	23.4	L1	10.1
3.854	37.0	---	56.0	19.0	N	9.7
3.869	---	29.7	46.0	16.3	N	9.7
4.979	---	27.8	46.0	18.2	L1	9.8
5.028	35.5	---	60.0	24.5	N	9.7
12.485	34.4	---	60.0	25.6	L1	9.9
12.534	---	28.8	50.0	21.2	L1	9.9

Note 2) Level (QP and/or CAV) = Meter Reading (QP and/or CAV) + Corr. (LISN Insertion Loss + Cable Loss)
 Margin (QP and/or CAV) = Limit – Level (QP and/or CAV)
 QP = Quasi-Peak, CAV = CISPR-Average, Corr. = Correction Factor

5.2 Radiated Emission

The following data lists the significant emission frequencies, measured levels, correction factors (for antenna and cables), orientation of table, polarization and height of antenna, the corrected reading, the limit, and the amount of margin.

Peak measurements were made over the changeable frequency range 30 MHz to 1 GHz at a measurement distance of 3 m for the following antenna and turntable arrangements:

Antenna Height [cm]	Antenna Polarization	Resolution Bandwidth [kHz]	Video Bandwidth [kHz]	Turntable position [degrees]
100 ~ 400	Horizontal, Vertical	120	300	Continuous

Measurements within 6 dB of the limit were then maximized by adjusting turntable position.

Final measurements were made using quasi-peak detector.

Peak/CISPR-Average measurements were made over the changeable frequency range 1 GHz to 40 GHz or 5th harmonics of the highest frequency generated or used in the device or on which the device operates or tunes at a measurement distance of 3 m for the following antenna and turntable arrangements. The measurements above 1 GHz were performed with the bore-sighting antenna aimed at the EUT.

Antenna Height [cm]	Antenna Polarization	Resolution Bandwidth [MHz]	Video Bandwidth [MHz]	Turntable position [degrees]
100 ~ 400	Horizontal, Vertical	1	3	Continuous

Measurements within 6 dB of the limit were then maximized by adjusting turntable position.

Final measurements were made using peak and CISPR-average detectors.

Limits for Radiated emission of Class B at a measuring distance of 3 m and 10 m

Frequency range Limits [MHz]	Field Strength		
	3 m [$\mu\text{V/m}$]	3 m [dB($\mu\text{V/m}$)]	10 m [dB($\mu\text{V/m}$)]
30 to 88	100	40.0	29.5
88 to 216	150	43.5	33.0
216 to 960	200	46.0	35.5
Above 960	500	54.0	43.5

Note) Distance correction formula from D1(3m) to D2(10m)

: Limit at D2 = Limit at D1 + 20Log(D1 /D2)

Results checked manually; and points close to the limit line were re-measured.

5.2.1 Test instrumentation

EMC No.	Test Instrument	Model name	Manufacturer	Serial No.	Next Calibration	
					Date	Interval (Month)
E5I-021	EMI Test Receiver	ESU40	R&S	100376	2022-02-04	12
E5I-020	EMI Test Receiver	ESU40	R&S	100375	2022-09-23	12
E5I-072	BiLog Antenna	CBL6112D	TESEQ	36009	2022-05-15	24
E5I-223	6 dB Fixed Attenuator	8491B-006	Agilent	58359	2022-05-15	24
E5I-093	Preamplifier	310N	SONOMA	273122	2022-01-21	12
E5I-149	Horn Antenna	HF907	R&S	102525	2022-07-10	24
E5I-040	Signal Conditioning Unit	SCU-18	R&S	10210	2022-04-06	12
E5I-037	WideBand Horn Antenna	WBH 18-40K	R&S	11201	2023-02-15	24
E5I-042	Signal Conditioning Unit	SCU-40A	R&S	10004	2022-09-10	12
E5I-023	Signal Generator	SMB100A	R&S	175857	2022-02-03	12
-	Test software	EP7RE	TOYO	Ver 8.0.20	-	-
-	Test software	EMC32	R&S	Ver 9.25.00	-	-

5.2.1 Temperature and humidity condition

Test date	2022-01-12 / 2022-01-17	Test engineer	Eun-Kyung Oh
Climate condition	Ambient temperature	(23.1 ± 0.5) °C	Limit (15.0 to 35.0) °C
	Relative humidity	(39.7 ± 0.5) % R.H.	Limit (25.0 to 75.0) % R.H.
	Atmospheric pressure	(101.8 ± 0.5) kPa	Limit (86.0 to 106.0) kPa
Test place	Semi-Anechoic Chamber (SAC5)		

5.2.3 Test Results

□ Operating Mode 1

- Frequencies below 1 GHz

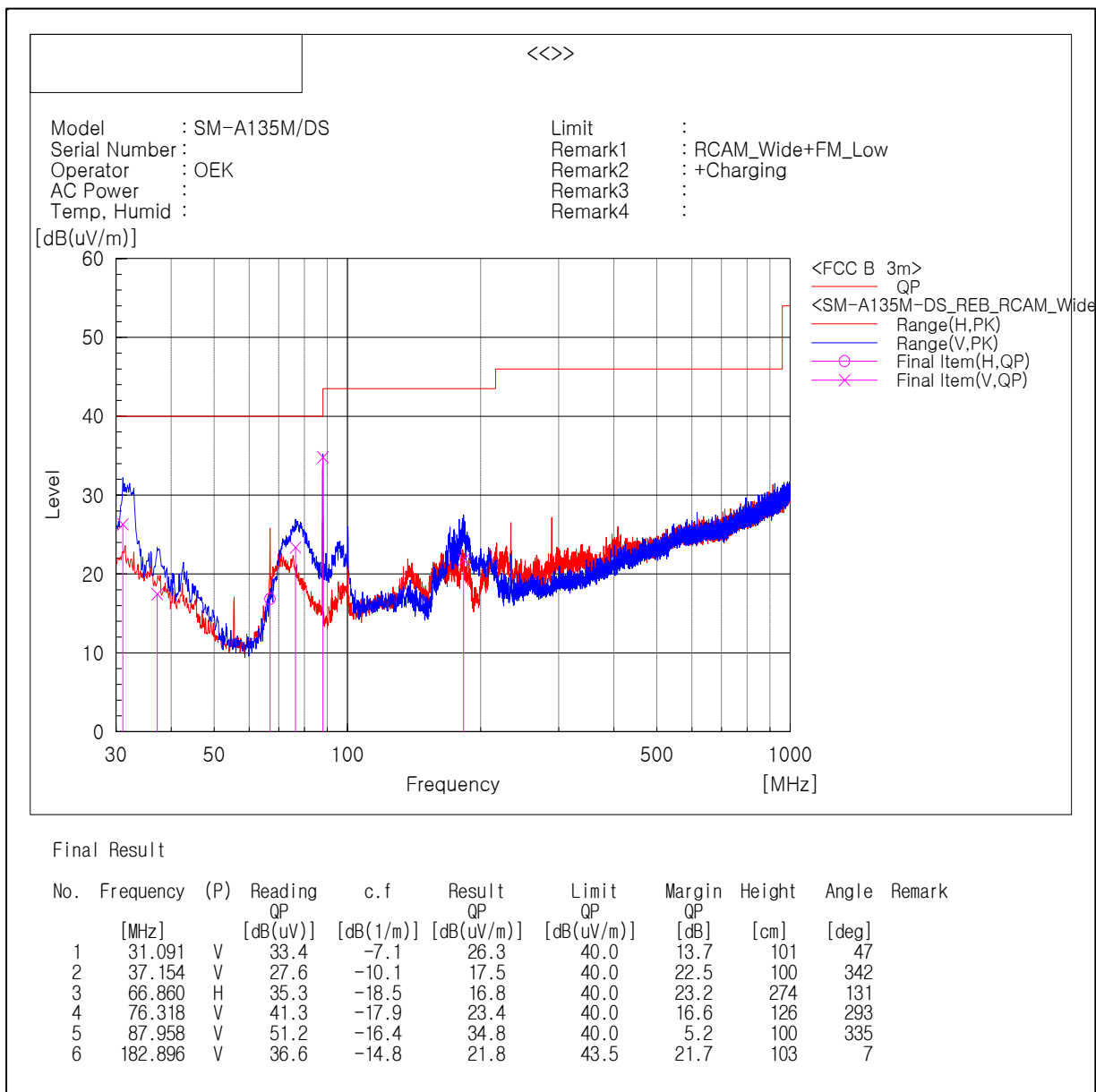

Remark : Radiated emission (Rx frequency - 87.958 MHz) from the transceiver shall be ignored.

Note1) Receiving antenna polarization : Horizontal, Vertical

Test Distance : 3 m, Antenna Height : 1 to 4 meters

Result (QP) = Reading (QP) + c.f (Antenna Factor + Cable Loss - Amp. Gain)

Margin (QP) = Limit - Level (QP)

QP = Quasi-Peak, c.f = Correction Factor

- Frequencies above 1 GHz

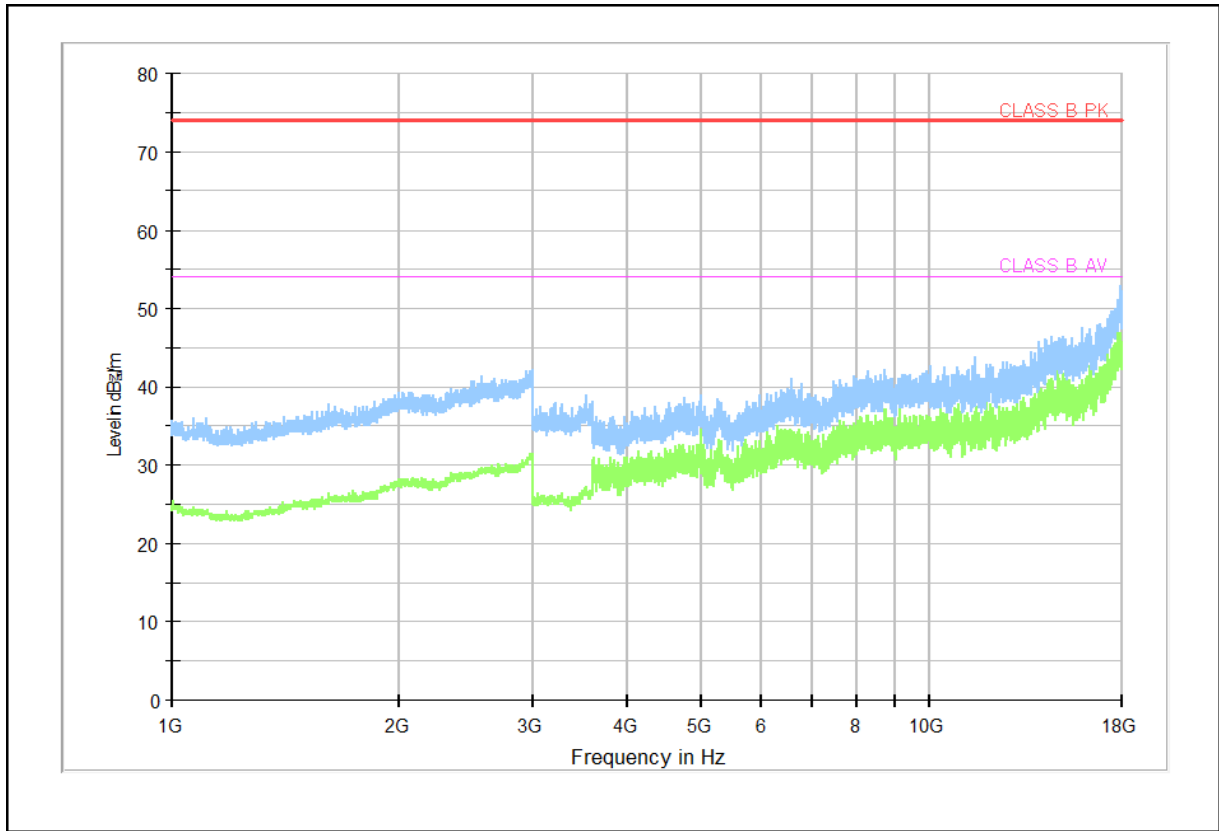

Note 1) We have also tested from 18 GHz to 30 GHz and found no emissions.

Note 2) Receiving antenna polarization : Horizontal, Vertical

Test Distance : 3 m, Antenna Height : 1 to 4 meters

Level (PK and/or CAV) = Reading (PK and/or CAV) + Corr. (Antenna Factor + Cable Loss - Amp. Gain)

Margin (PK and/or CAV) = Limit – Level (PK and/or CAV)

PK = Peak, CAV = CISPR-Average, Corr. = Correction Factor

□ Operating Mode 2

- Frequencies below 1 GHz

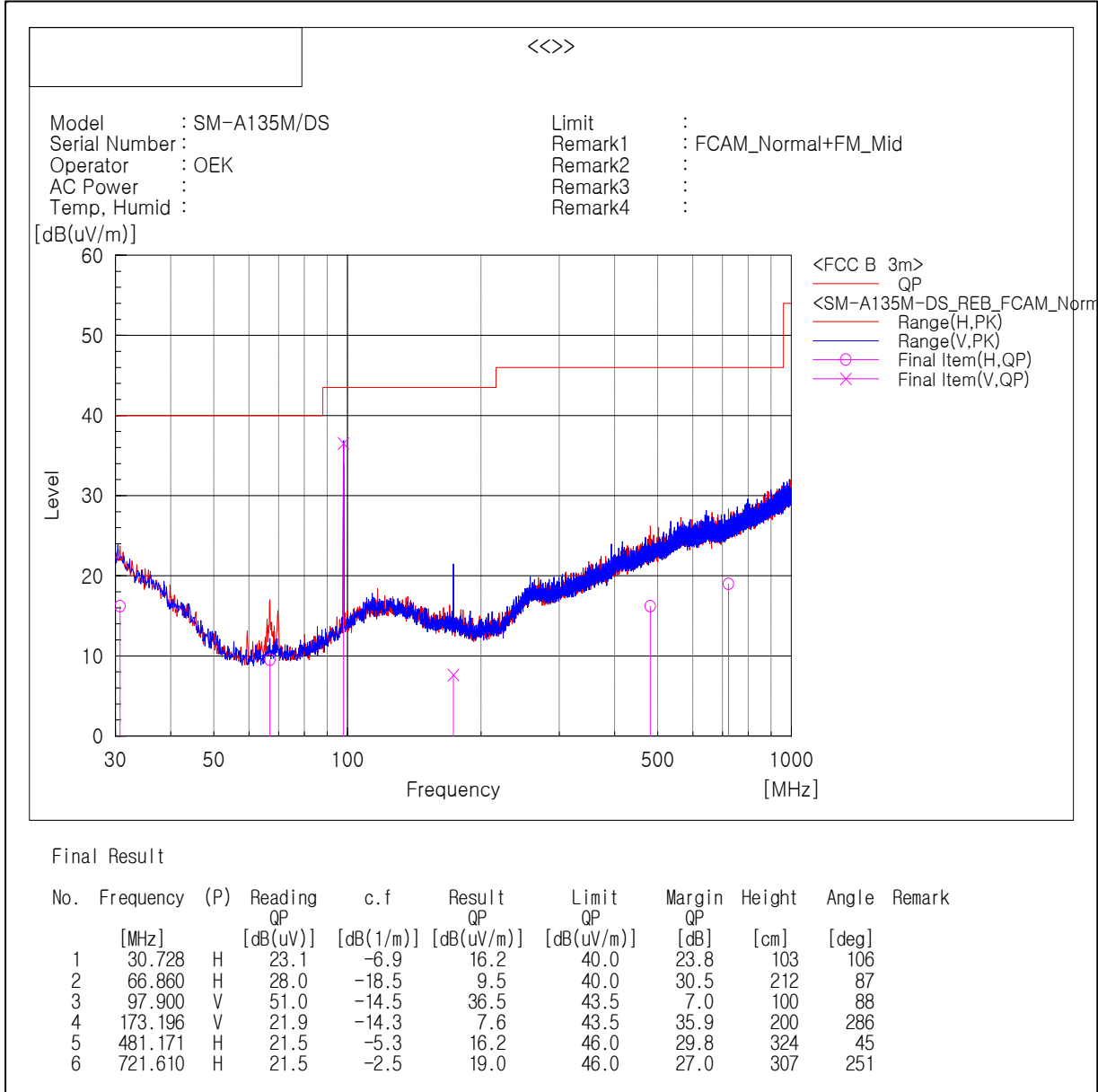

Remark : Radiated emission (Rx frequency – 97.900 MHz) from the transceiver shall be ignored.

Note1) Receiving antenna polarization : Horizontal, Vertical

Test Distance : 3 m, Antenna Height : 1 to 4 meters

Result (QP) = Reading (QP) + c.f (Antenna Factor + Cable Loss - Amp. Gain)

Margin (QP) = Limit – Level (QP)

QP = Quasi-Peak, c.f = Correction Factor

- Frequencies above 1 GHz

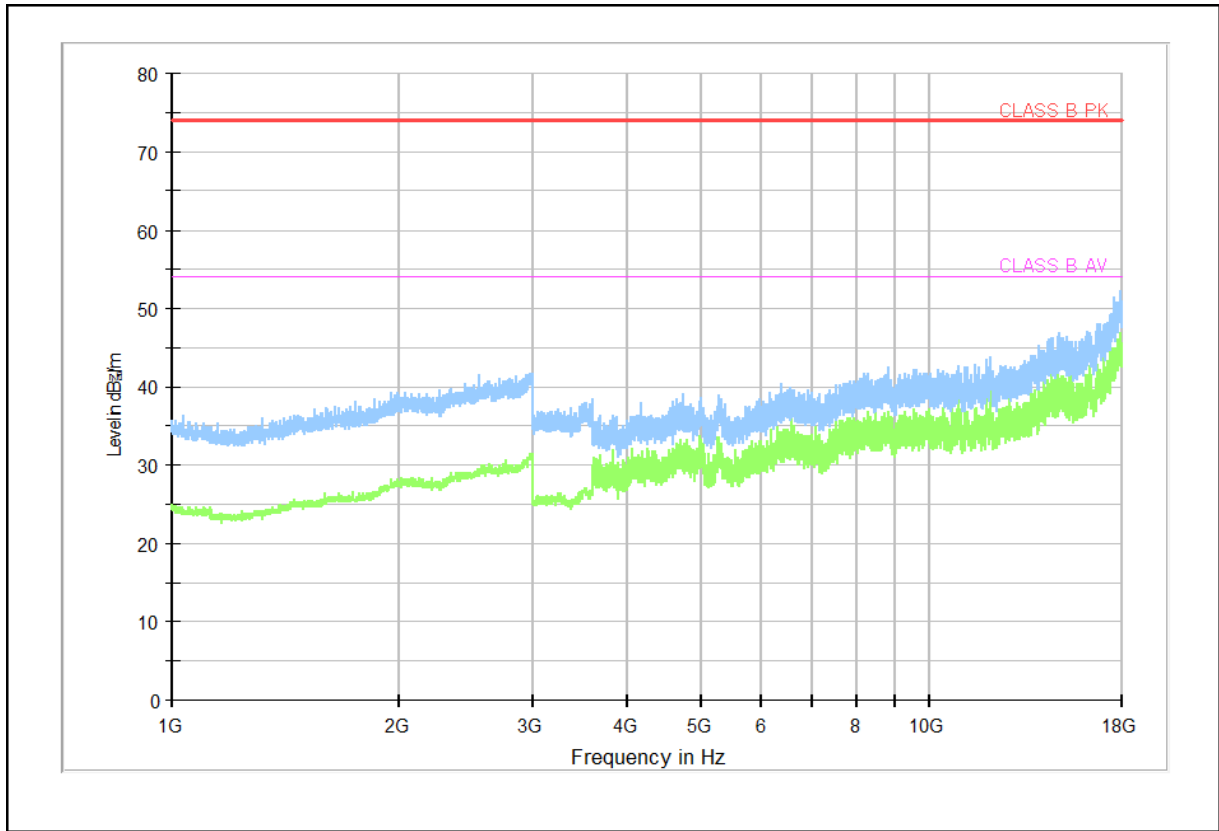

Note 1) We have also tested from 18 GHz to 30 GHz and found no emissions.

Note 2) Receiving antenna polarization : Horizontal, Vertical

Test Distance : 3 m, Antenna Height : 1 to 4 meters

Level (PK and/or CAV) = Reading (PK and/or CAV) + Corr. (Antenna Factor + Cable Loss - Amp. Gain)

Margin (PK and/or CAV) = Limit – Level (PK and/or CAV)

PK = Peak, CAV = CISPR-Average, Corr. = Correction Factor

□ Operating Mode 3

- Frequencies below 1 GHz

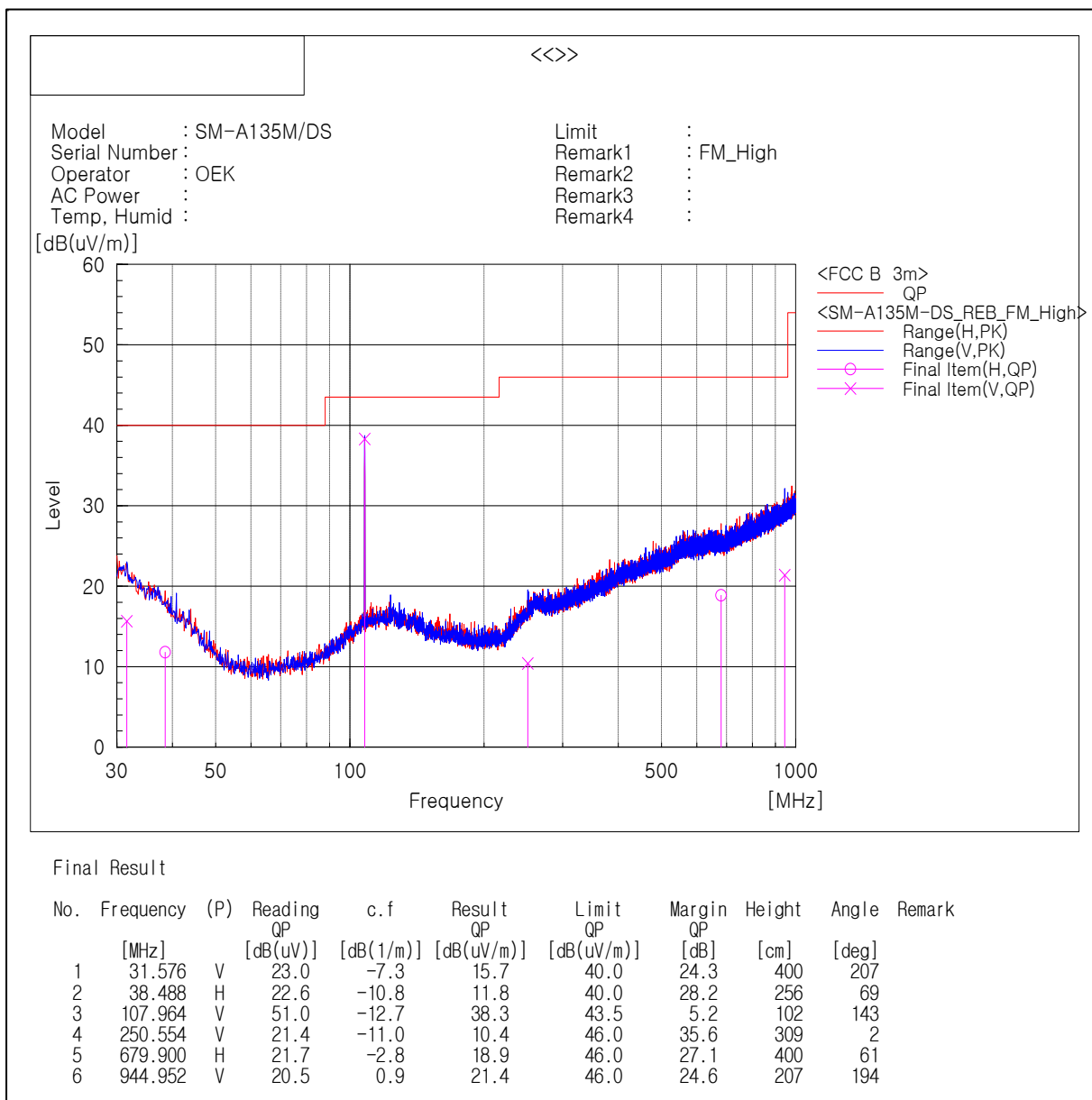

Remark : Radiated emission (Rx frequency - 107.964 MHz) from the transceiver shall be ignored.

Note1) Receiving antenna polarization : Horizontal, Vertical

Test Distance : 3 m, Antenna Height : 1 to 4 meters

Result (QP) = Reading (QP) + c.f (Antenna Factor + Cable Loss - Amp. Gain)

Margin (QP) = Limit - Level (QP)

QP = Quasi-Peak, c.f = Correction Factor

- Frequencies above 1 GHz

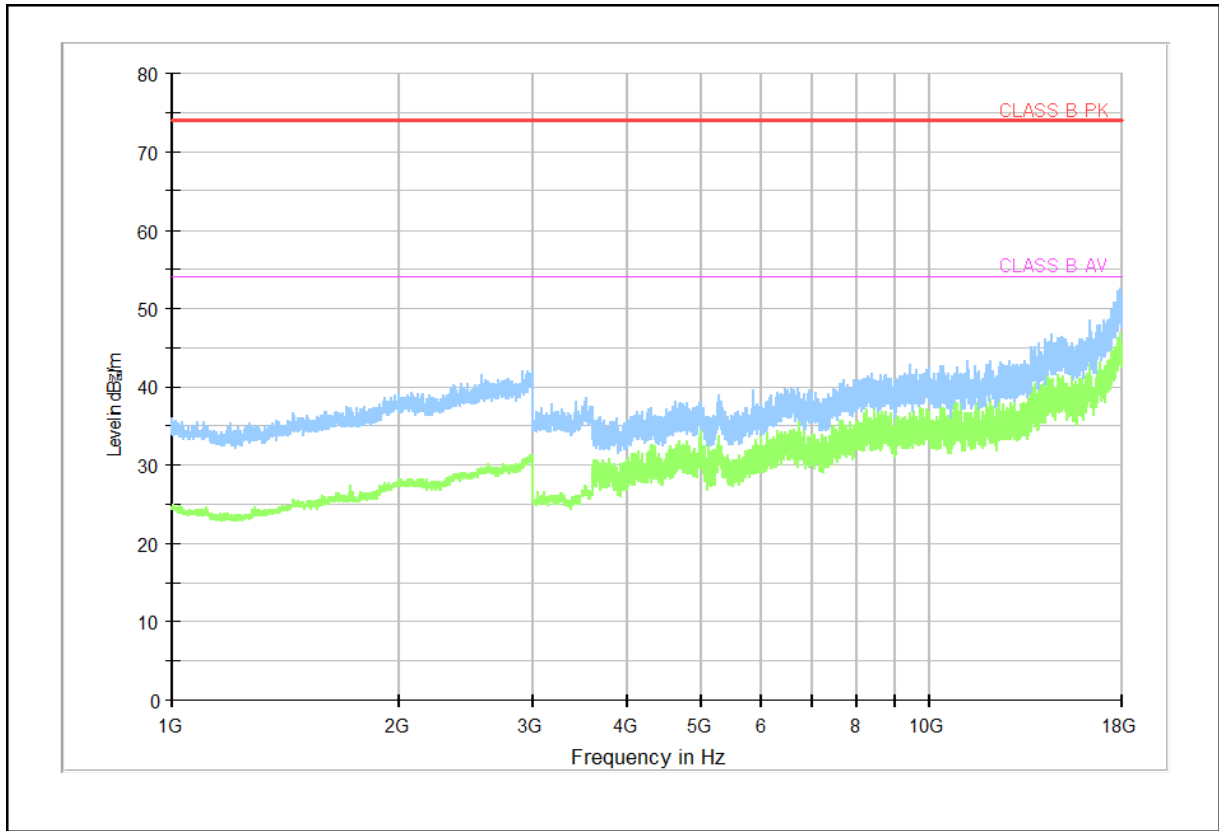

Note 1) We have also tested from 18 GHz to 30 GHz and found no emissions.

Note 2) Receiving antenna polarization : Horizontal, Vertical

Test Distance : 3 m, Antenna Height : 1 to 4 meters

Level (PK and/or CAV) = Reading (PK and/or CAV) + Corr. (Antenna Factor + Cable Loss - Amp. Gain)

Margin (PK and/or CAV) = Limit – Level (PK and/or CAV)

PK = Peak, CAV = CISPR-Average, Corr. = Correction Factor

□ Operating Mode 4

- Frequencies below 1 GHz

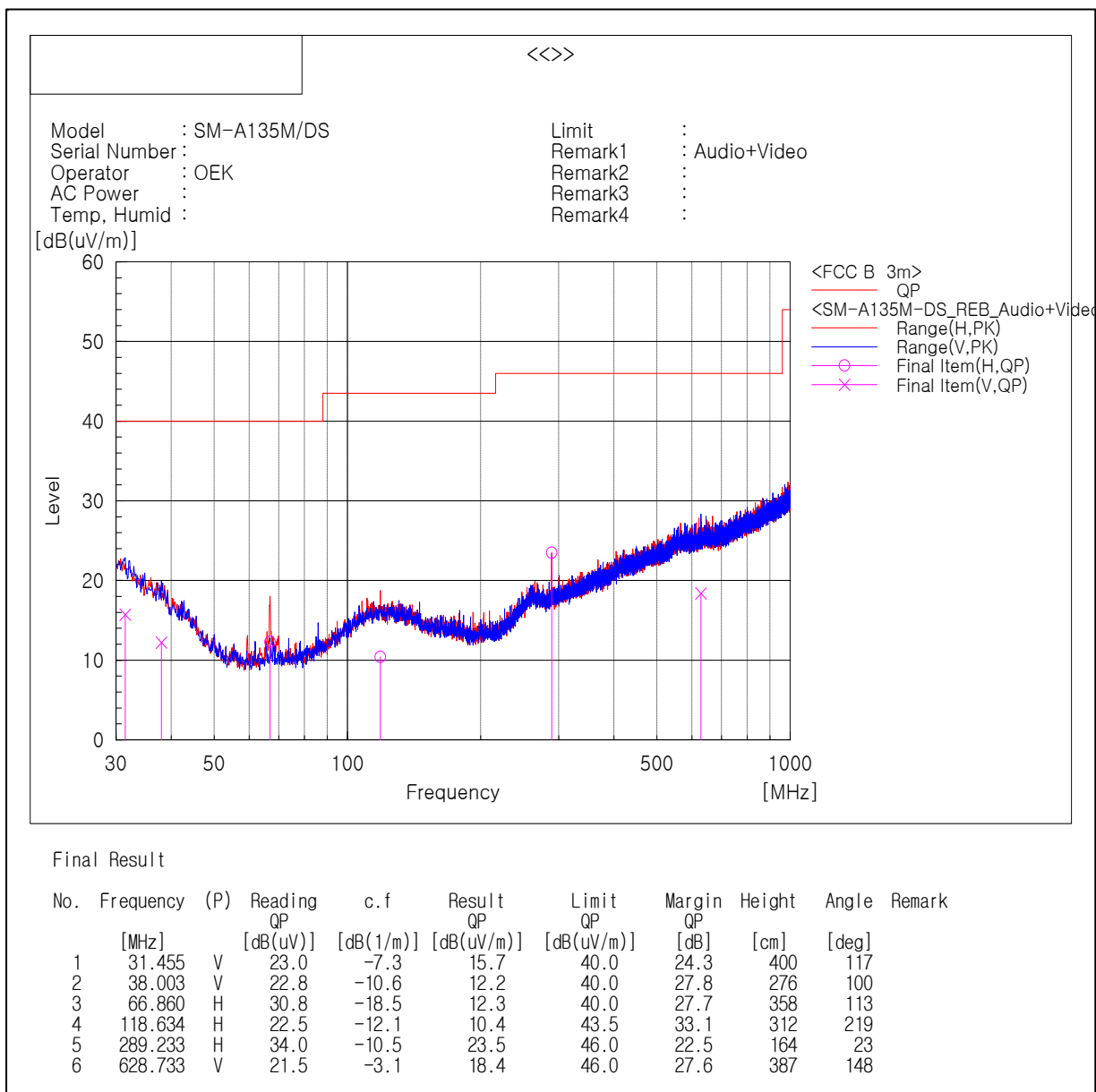

Note1) Receiving antenna polarization : Horizontal, Vertical

Test Distance : 3 m, Antenna Height : 1 to 4 meters

Result (QP) = Reading (QP) + c.f (Antenna Factor + Cable Loss - Amp. Gain)

Margin (QP) = Limit - Level (QP)

QP = Quasi-Peak, c.f = Correction Factor

- Frequencies above 1 GHz

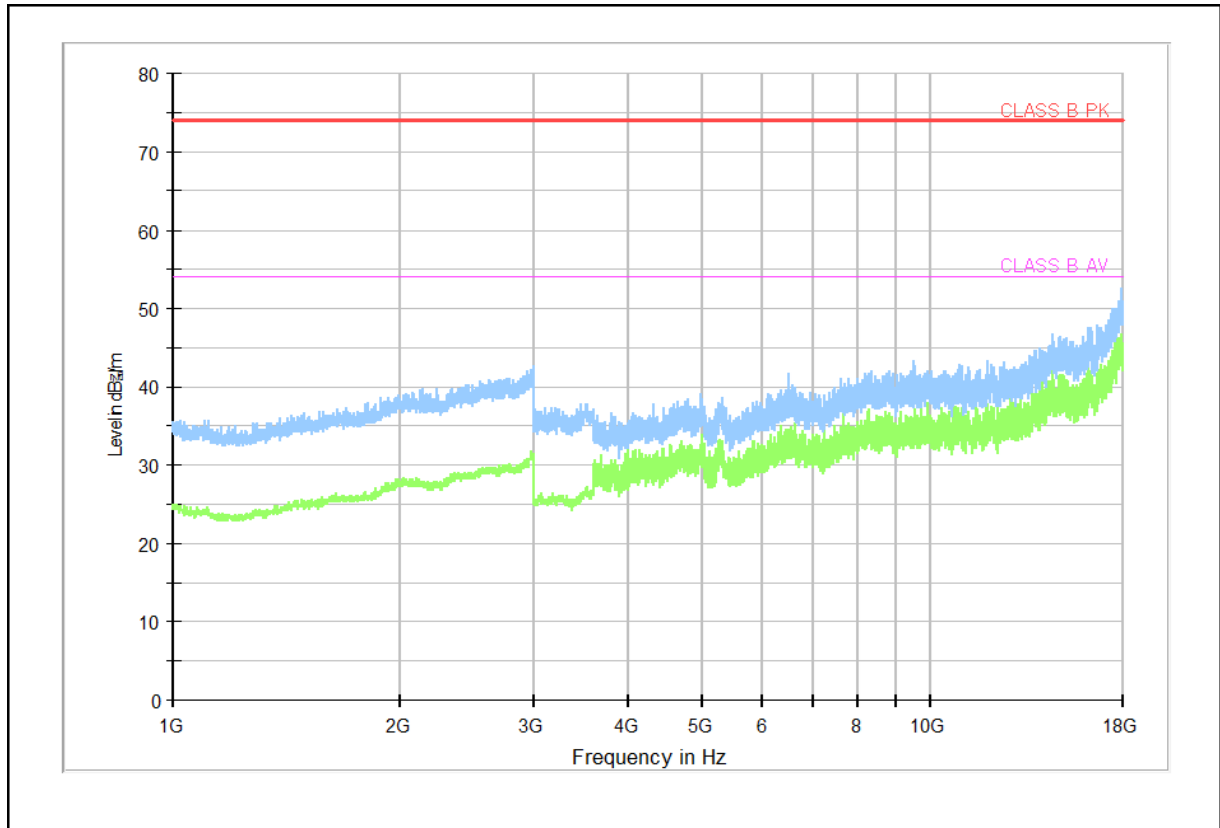

Note 1) We have also tested from 18 GHz to 30 GHz and found no emissions.

Note 2) Receiving antenna polarization : Horizontal, Vertical

Test Distance : 3 m, Antenna Height : 1 to 4 meters

Level (PK and/or CAV) = Reading (PK and/or CAV) + Corr. (Antenna Factor + Cable Loss - Amp. Gain)

Margin (PK and/or CAV) = Limit – Level (PK and/or CAV)

PK = Peak, CAV = CISPR-Average, Corr. = Correction Factor

□ Operating Mode 5

- Frequencies below 1 GHz

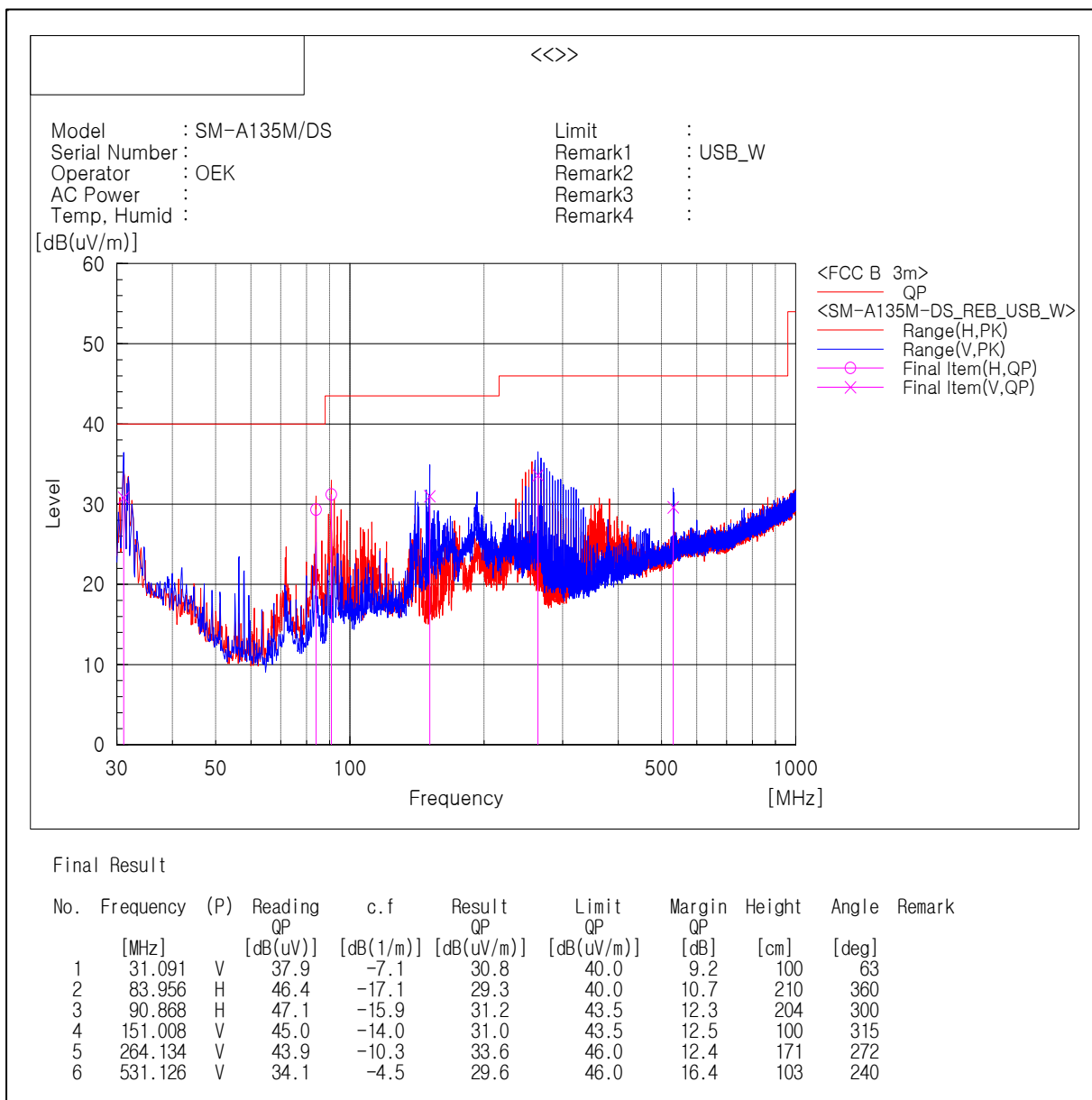

Note1) Receiving antenna polarization : Horizontal, Vertical

Test Distance : 3 m, Antenna Height : 1 to 4 meters

Result (QP) = Reading (QP) + c.f (Antenna Factor + Cable Loss - Amp. Gain)

Margin (QP) = Limit - Level (QP)

QP = Quasi-Peak, c.f = Correction Factor

- Frequencies above 1 GHz

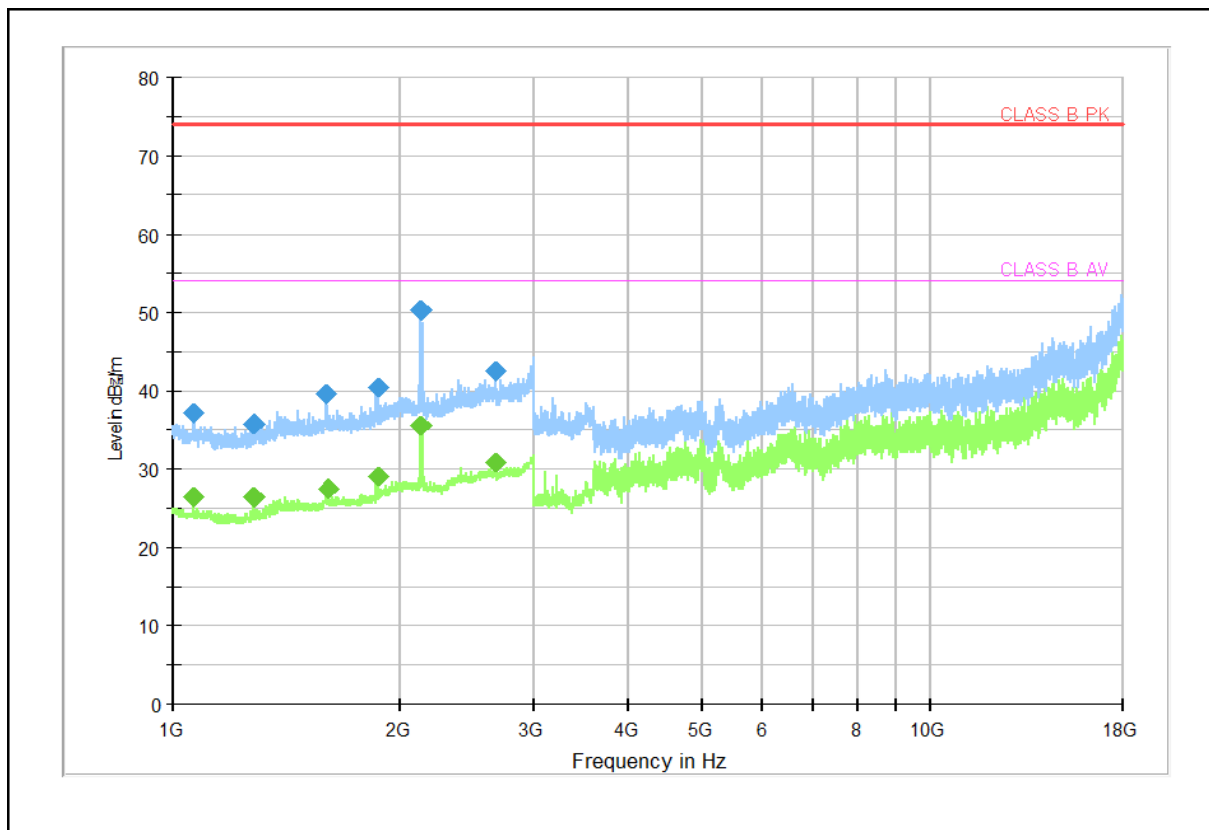

Frequency (MHz)	PK (dBµV/m)	CAV (dBµV/m)	Limit (dBµV/m)	Margin (dB)	Height (cm)	Pol	Azimuth (deg)	Corr. (dB)
1 062.500	---	26.33	54.00	27.67	100.70	V	350.00	6.15
1 065.000	37.08	---	74.00	36.92	100.80	H	0.00	6.16
1 276.000	---	26.40	54.00	27.60	101.20	H	83.00	6.62
1 276.500	35.80	---	74.00	38.20	101.40	H	186.00	6.62
1 593.500	39.53	---	74.00	34.47	100.50	V	130.00	9.27
1 598.000	---	27.47	54.00	26.53	100.40	V	73.00	9.32
1 863.000	40.48	---	74.00	33.52	101.90	V	100.00	10.40
1 865.500	---	29.13	54.00	24.87	101.70	V	71.00	10.44
2 128.500	---	35.60	54.00	18.40	100.80	V	338.00	11.90
2 129.000	50.34	---	74.00	23.66	100.50	V	341.00	11.90
2 658.000	---	30.81	54.00	23.19	101.20	V	341.00	13.97
2 660.000	42.38	---	74.00	31.62	101.10	V	328.00	13.97

Note 1) We have also tested from 18 GHz to 30 GHz and found no emissions.

Note 2) Receiving antenna polarization : Horizontal, Vertical

Test Distance : 3 m, Antenna Height : 1 to 4 meters

Level (PK and/or CAV) = Reading (PK and/or CAV) + Corr. (Antenna Factor + Cable Loss - Amp. Gain)

Margin (PK and/or CAV) = Limit – Level (PK and/or CAV)

PK = Peak, CAV = CISPR-Average, Corr. = Correction Factor