



FCC RF Test Report

APPLICANT : SAMSUNG Electronics Co., LTD.
EQUIPMENT : Mobile Phone
BRAND NAME : Samsung
MODEL NAME : SHV-E270L
MARKETING NAME : BAFFIN
FCC ID : A3LSHVE270L
STANDARD : FCC 47 CFR Part 2, 24(E)
CLASSIFICATION : PCS Licensed Transmitter Held to Ear (PCE)

The product was received on Oct. 09, 2012 and completely tested on Oct. 25, 2012. We, SPORTON INTERNATIONAL INC., would like to declare that the tested sample has been evaluated in accordance with the procedures given in ANSI / TIA / EIA-603-C-2004 and shown compliance with the applicable technical standards.

The test results in this report apply exclusively to the tested model / sample. Without written approval of SPORTON INTERNATIONAL INC., the test report shall not be reproduced except in full.

Reviewed by:

Jones Tsai / Manager



SPORTON INTERNATIONAL INC.

No. 52, Hwa Ya 1st Rd., Hwa Ya Technology Park, Kwei-Shan Hsiang, Tao Yuan Hsien, Taiwan, R.O.C.



TABLE OF CONTENTS

REVISION HISTORY.....3

SUMMARY OF TEST RESULT4

1 GENERAL DESCRIPTION.....5

 1.1 Applicant.....5

 1.2 Manufacturer5

 1.3 Feature of Equipment Under Test.....5

 1.4 Maximum ERP/EIRP Power, Frequency Tolerance, and Emission Designator6

 1.5 Testing Site6

 1.6 Applied Standards7

 1.7 Ancillary Equipment List.....7

2 TEST CONFIGURATION OF EQUIPMENT UNDER TEST.....8

 2.1 Test Mode.....8

 2.2 Connection Diagram of Test System9

3 TEST RESULT.....10

 3.1 Conducted Output Power Measurement.....10

 3.2 Peak-to-Average Ratio12

 3.3 Effective Radiated Power and Effective Isotropic Radiated Power Measurement20

 3.4 Occupied Bandwidth and 26dB Bandwidth Measurement.....23

 3.5 Band Edge Measurement.....37

 3.6 Conducted Spurious Emission Measurement.....42

 3.7 Field Strength of Spurious Radiation Measurement53

 3.8 Frequency Stability Measurement.....60

4 LIST OF MEASURING EQUIPMENT64

5 UNCERTAINTY OF EVALUATION65



SUMMARY OF TEST RESULT

Report Section	FCC Rule	IC Rule	Description	Limit	Result	Remark
3.1	§2.1046	N/A	Conducted Output Power	N/A	PASS	-
3.2	§24.232(d)	N/A	Peak-to-Average Ratio	< 13 dB	PASS	-
3.3	§24.232(c)	RSS-133 (6.4) SRSP-510(5.1.2)	Equivalent Isotropic Radiated Power	< 2 Watts	PASS	-
3.4	§2.1049 §24.238(a)	N/A	Occupied Bandwidth	N/A	PASS	-
3.5	§2.1051 §24.238(a)	RSS-133 (6.5.1)	Band Edge Measurement	< 43+10log ₁₀ (P[Watts])	PASS	-
3.6	§2.1051 §24.238(a)	RSS-133 (6.5.1)	Conducted Spurious Emission	< 43+10log ₁₀ (P[Watts])	PASS	-
3.7	§2.1053 §24.238(a)	RSS-133 (6.5.1)	Field Strength of Spurious Radiation	< 43+10log ₁₀ (P[Watts])	PASS	Under limit 9.70 dB at 13160.000 MHz
3.8	§2.1055 §24.235	RSS-133(6.3)	Frequency Stability for Temperature & Voltage	< 2.5 ppm	PASS	-

1 General Description

1.1 Applicant

SAMSUNG Electronics Co., LTD.

IT center, 416, Maetan-3dong, Yeongtong-gu, Suwon-city, Gyeonggi-do, Korea

1.2 Manufacturer

SAMSUNG Electronics Co., LTD.

IT center, 416, Maetan-3dong, Yeongtong-gu, Suwon-city, Gyeonggi-do, Korea

1.3 Feature of Equipment Under Test

Product Feature	
Equipment	Mobile Phone
Brand Name	Samsung
Model Name	SHV-E270L
Marketing Name	BAFFIN
FCC ID	A3LSHVE270L
EUT supports Radios application	GSM/GPRS/WCDMA/HSPA WLAN 11abgn / Bluetooth
HW Version	REV0.1
SW Version	E270L.001
EUT Stage	Identical Prototype

Remark: The above EUT's information was declared by manufacturer. Please refer to the specifications or user's manual for more detailed description.

Product Specification subjective to this standard	
Tx Frequency	GSM1900: 1850.2 MHz ~ 1909.8MHz WCDMA Band II: 1852.4 MHz ~ 1907.6 MHz
Rx Frequency	GSM1900: 1930.2 MHz ~ 1989.8 MHz WCDMA Band II: 1932.4 MHz ~ 1987.6 MHz
Maximum Output Power to Antenna	GSM1900 : 30.50 dBm WCDMA Band II : 23.05 dBm
Antenna Type	PIFA Antenna
Type of Modulation	GSM: GMSK GPRS: GMSK WCDMA: QPSK (Uplink) HSDPA: QPSK (Uplink) HSUPA: QPSK (Uplink)

1.4 Maximum ERP/EIRP Power, Frequency Tolerance, and Emission Designator

FCC Rule	System	Type of Modulation	Maximum ERP/EIRP (W)	Frequency Tolerance (% , Hz, ppm)	Emission Designator
Part 24	GSM1900 GSM	GMSK	0.5781	0.05 ppm	244KGXW
Part 24	WCDMA Band II RMC 12.2Kbps	QPSK	0.0989	0.01 ppm	4M24F9W

1.5 Testing Site

Test Site	SPORTON INTERNATIONAL INC.		
Test Site Location	No. 52, Hwa Ya 1 st Rd., Hwa Ya Technology Park, Kwei-Shan Hsiang, Tao Yuan Hsien, Taiwan, R.O.C. TEL: +886-3-327-3456 FAX: +886-3-328-4978		
Test Site No.	Sporton Site No.		FCC/IC Registration No.
	TH02-HY	03CH07-HY	722060/4086B-1



1.6 Applied Standards

According to the specifications of the manufacturer, the EUT must comply with the requirements of the following standards:

- Preliminary Guidance for Receiving Applications for Certification of 3G Device. May 9, 2006.
- FCC 47 CFR Part 2, 24(E)
- ANSI / TIA / EIA-603-C-2004
- FCC KDB 971168 D01 Power Meas. License Digital Systems v01
- IC RSS-133 Issue 5

Remark:

1. All test items were verified and recorded according to the standards and without any deviation during the test.
2. This EUT has also been tested and complied with the requirements of FCC Part 15, Subpart B, recorded in a separate test report.

1.7 Ancillary Equipment List

Item	Equipment	Trade Name	Model No.	FCC ID	Data Cable	Power Cord
1.	System Simulator	Agilent	8960	N/A	N/A	Unshielded, 1.8 m

2 Test Configuration of Equipment Under Test

2.1 Test Mode

During all testing, EUT is in link mode with base station emulator at maximum power level. The spurious emission measurements were carried out in semi-anechoic chamber with 3-meter test range, and EUT is rotated on three test planes to find out the worst emission.

Frequency range investigated for radiated emission is as follows:

1. 30 MHz to 19000 MHz for GSM1900 and WCDMA Band II.

Test Modes		
Band	Radiated TCs	Conducted TCs
GSM 1900	■ GSM Link	■ GSM Link
WCDMA Band II	■ RMC 12.2Kbps Link	■ RMC 12.2Kbps Link

Note:

1. The maximum power levels are GSM mode for GMSK link, and RMC 12.2Kbps mode for WCDMA band II, only these modes were used for all tests.
2. Because there are individual antennas for each WWAN, WLAN, and Bluetooth, the co-location test modes are not required.

The conducted power tables are as follows:

Conducted Power (*Unit: dBm)			
Band	GSM1900		
Channel	512	661	810
Frequency	1850.2	1880.0	1909.8
GSM	29.82	30.38	30.50
GPRS 8	29.81	30.37	30.49
GPRS 10	27.51	28.05	28.13

Conducted Power (*Unit: dBm)			
Band	WCDMA Band II		
Channel	9262	9400	9538
Frequency	1852.4	1880.0	1907.6
RMC 12.2K	23.04	23.05	23.02
HSDPA Subtest-1	20.42	20.55	20.44
HSDPA Subtest-2	20.32	20.51	20.32
HSDPA Subtest-3	20.38	20.45	20.35
HSDPA Subtest-4	19.55	19.86	19.58
HSUPA Subtest-1	19.74	19.96	19.93
HSUPA Subtest-2	18.57	18.92	18.74
HSUPA Subtest-3	19.38	19.88	19.72
HSUPA Subtest-4	18.53	18.95	18.81
HSUPA Subtest-5	19.78	20.27	20.24

2.2 Connection Diagram of Test System

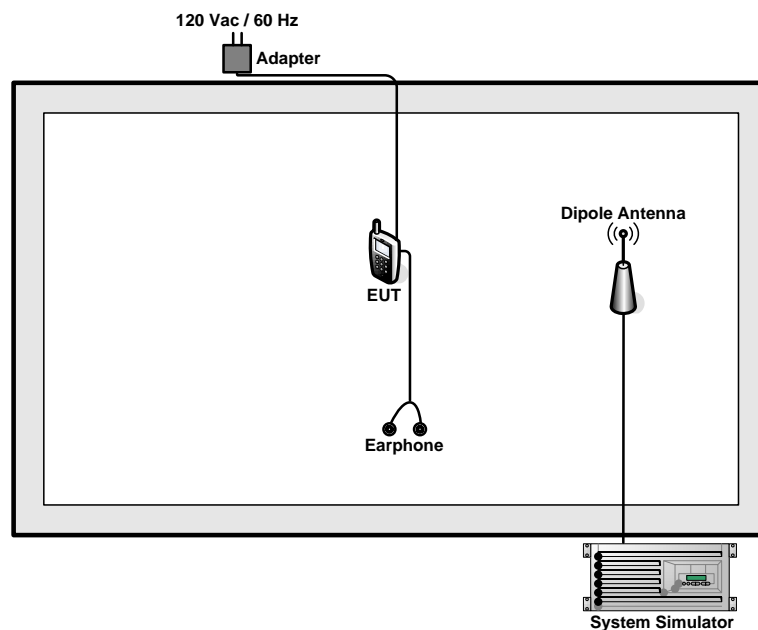

3 Test Result

3.1 Conducted Output Power Measurement

3.1.1 Description of the Conducted Output Power Measurement

A base station simulator was used to establish communication with the EUT. Its parameters were set to transmit the maximum power on the EUT. The measured power in the radio frequency on the transmitter output terminals shall be reported.

3.1.2 Measuring Instruments

See list of measuring instruments of this test report.

3.1.3 Test Procedures

1. The transmitter output port was connected to base station.
2. Set EUT at maximum power through base station.
3. Select lowest, middle, and highest channels for each band and different modulation.
4. Measure the maximum burst average power for GSM and maximum average power for other modulation signal.

3.1.4 Test Setup

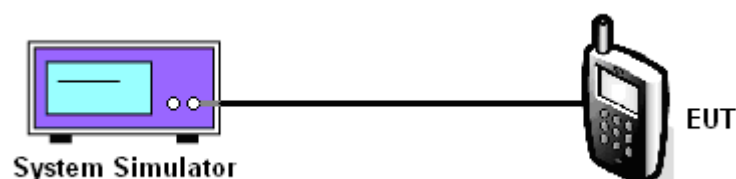



3.1.5 Test Result of Conducted Output Power

PCS Band						
Modes	GSM1900 (GSM)			WCDMA Band II (RMC 12.2Kbps)		
Channel	512 (Low)	661 (Mid)	810 (High)	9262 (Low)	9400 (Mid)	9538 (High)
Frequency (MHz)	1850.2	1880	1909.8	1852.4	1880	1907.6
Conducted Power (dBm)	29.82	30.38	30.50	23.04	23.05	23.02
Conducted Power (Watts)	0.96	1.09	1.12	0.20	0.20	0.20

Note: maximum burst average power for GSM, and maximum average power for WCDMA.

3.2 Peak-to-Average Ratio

3.2.1 Description of the PAR Measurement

Power Complementary Cumulative Distribution Function (CCDF) curves provide a means for characterizing the power peaks of a digitally modulated signal on a statistical basis. A CCDF curve depicts the probability of the peak signal amplitude exceeding the average power level. Most contemporary measurement instrumentation include the capability to produce CCDF curves for an input signal provided that the instrument's resolution bandwidth can be set wide enough to accommodate the entire input signal bandwidth. In measuring transmissions in this band using an average power technique, the peak-to-average ratio (PAR) of the transmission may not exceed 13 dB.

3.2.2 Measuring Instruments

See list of measuring instruments of this test report.

3.2.3 Test Procedures

1. The EUT was connected to Spectrum Analyzer and Base Station via power divider.
2. For GSM/EGPRS operating modes:
 - a. Set the RBW = 1MHz, VBW = 1MHz, Peak detector in spectrum analyzer.
 - b. Set EUT in maximum power output, and triggered the burst signal.
 - c. Measured respectively the Peak level and Mean level, and the deviation was recorded as Peak to Average Ratio.
3. For UMTS operating modes:
 - a. Set the CCDF (Complementary Cumulative Distribution Function) option in spectrum analyzer.
 - b. The highest RF powers were measured and recorded the maximum PAPR level associated with a probability of 0.1 %.

3.2.4 Test Setup

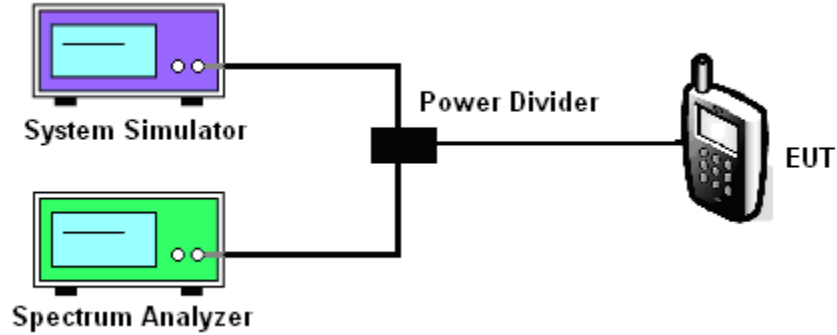

3.2.5 Test Result of Peak-to-Average Ratio

PCS Band						
Modes	GSM1900 (GSM)			WCDMA Band II (RMC 12.2Kbps)		
Channel	512 (Low)	661 (Mid)	810 (High)	9262 (Low)	9400 (Mid)	9538 (High)
Frequency (MHz)	1850.2	1880	1909.8	1852.4	1880	1907.6
Peak-to-Average Ratio (dB)	0.08	0.07	0.07	2.68	2.88	2.64

3.2.6 Test Result (Plots) of Peak-to-Average Ratio

Band :	GSM 1900	Test Mode :	GSM Link
--------	----------	-------------	----------

Peak-to-Average Ratio on Channel 512 (1850.2 MHz)

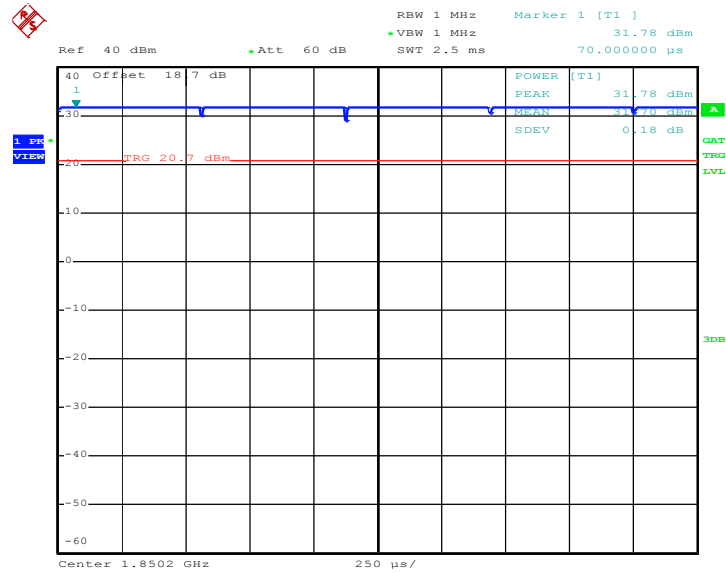

Date: 16.OCT.2012 14:15:48

Note:

The total loss is 18.7dB of the RF cable and attenuator, and has been compensated to the spectrum analyzer by setting into the amplitude level offset. That means the measured result shown on the spectrum analyzer has added the total loss and been compliance with the limit line.

Example: the Peak-to-Average Ratio test item, the peak point of fundamental signal is 31.78dBm, has added (offset) with the total loss = attenuator factor + cable loss = 18.7dB, where, cable loss = 8.7dB and 10dB attenuator, and then the Peak-to-Average Ratio is measured and compliance with the limit line. Hereafter, each plot of spectrum analyzer has been added the total loss respectively and to demonstrate in compliance with the limit line.



Peak-to-Average Ratio on Channel 661 (1880.0 MHz)

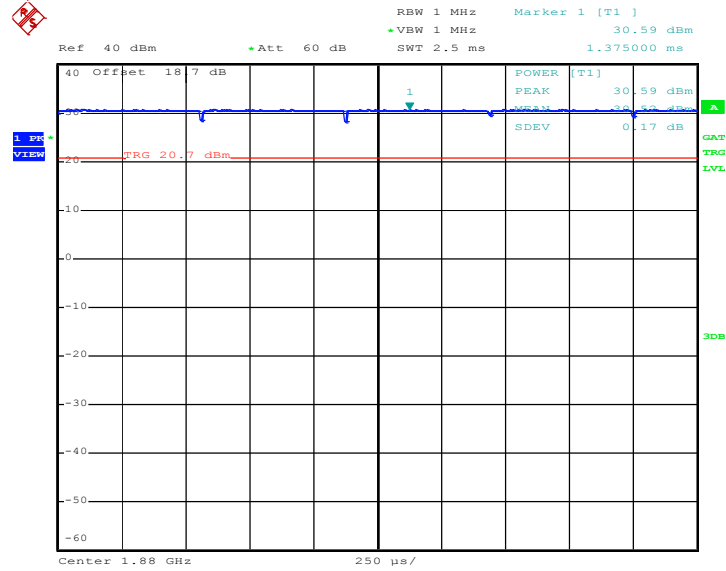

Date: 16.OCT.2012 14:15:03

Note:

The total loss is 18.7dB of the RF cable and attenuator, and has been compensated to the spectrum analyzer by setting into the amplitude level offset. That means the measured result shown on the spectrum analyzer has added the total loss and been compliance with the limit line.



Peak-to-Average Ratio on Channel 810 (1909.8 MHz)

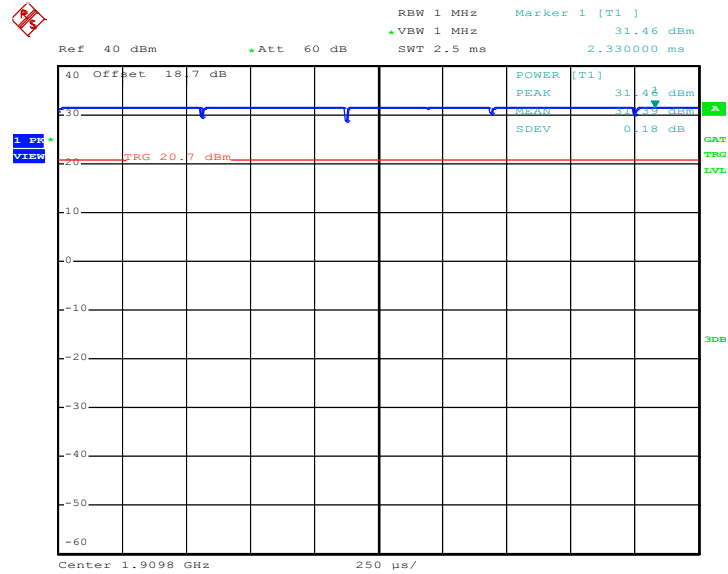

Date: 16.OCT.2012 14:14:11

Note:

The total loss is 18.7dB of the RF cable and attenuator, and has been compensated to the spectrum analyzer by setting into the amplitude level offset. That means the measured result shown on the spectrum analyzer has added the total loss and been compliance with the limit line.



Band :	WCDMA Band II	Test Mode :	RMC 12.2Kbps Link
---------------	---------------	--------------------	-------------------

Peak-to-Average Ratio on Channel 9262 (1852.4 MHz)

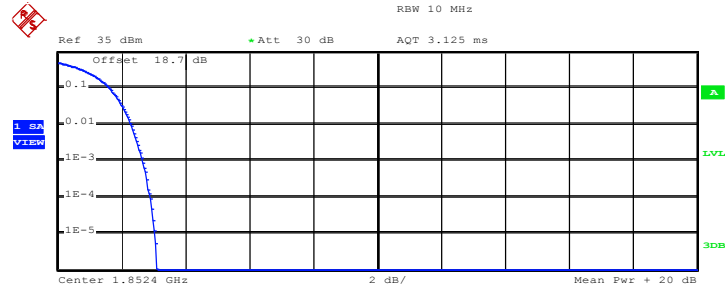

Complementary Cumulative Distribution Function (100000 samples)

Trace 1

Mean	23.53 dBm
Peak	26.65 dBm
Crest	3.11 dB
10 %	1.64 dB
1 %	2.32 dB
.1 %	2.68 dB
.01 %	2.92 dB

Date: 16.OCT.2012 14:42:46

Note:

The total loss is 18.7dB of the RF cable and attenuator, and has been compensated to the spectrum analyzer by setting into the amplitude level offset. That means the measured result shown on the spectrum analyzer has added the total loss and been compliance with the limit line.



Peak-to-Average Ratio on Channel 9400 (1880.0 MHz)

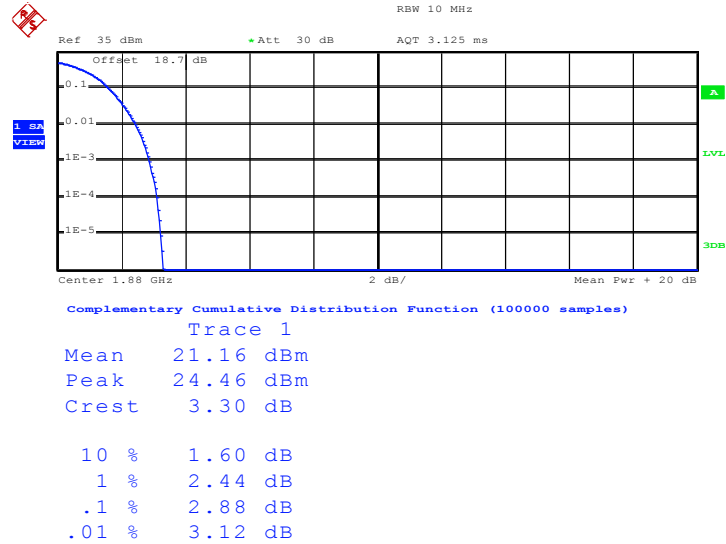

Date: 16.OCT.2012 14:40:52

Note:

The total loss is 18.7dB of the RF cable and attenuator, and has been compensated to the spectrum analyzer by setting into the amplitude level offset. That means the measured result shown on the spectrum analyzer has added the total loss and been compliance with the limit line.



Peak-to-Average Ratio on Channel 9538 (1907.6 MHz)

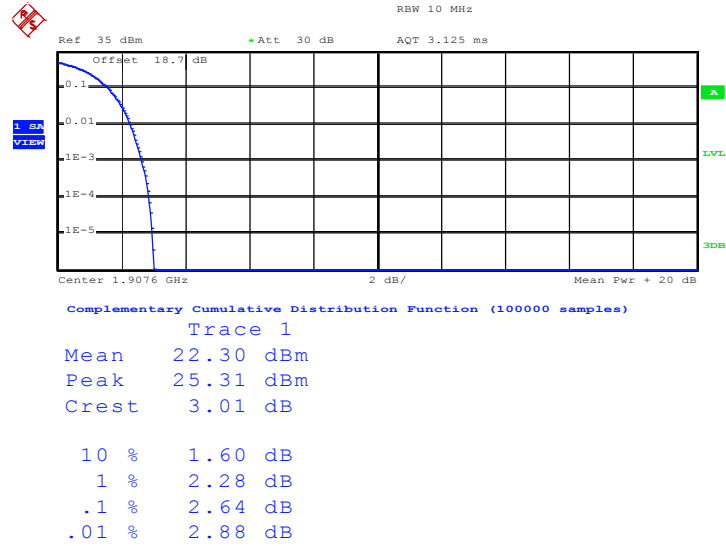

Date: 16.OCT.2012 14:42:00

Note:

The total loss is 18.7dB of the RF cable and attenuator, and has been compensated to the spectrum analyzer by setting into the amplitude level offset. That means the measured result shown on the spectrum analyzer has added the total loss and been compliance with the limit line.



3.3 Effective Radiated Power and Effective Isotropic Radiated Power Measurement

3.3.1 Description of the ERP/EIRP Measurement

The substitution method, in ANSI / TIA / EIA-603-C-2004, was used for ERP/EIRP measurement, and the spectrum analyzer configuration follows KDB 971168 D01 Power Meas. License Digital Systems v01. The ERP of mobile transmitters must not exceed 7 Watts and the EIRP of mobile transmitters are limited to 2 Watts.

3.3.2 Measuring Instruments

See list of measuring instruments of this test report.

3.3.3 Test Procedures

1. The EUT was placed on a non-conductive rotating platform with 0.8 meter height in a semi-anechoic chamber. The radiated emission at the fundamental frequency was measured at 3 m with a test antenna and a spectrum analyzer with RBW= 1MHz, VBW= 3MHz for GSM, RBW= 300KHz, VBW= 1MHz for WCDMA, and RMS detector settings per section 4.0 of KDB 971168 D01.
2. During the measurement, the EUT was enforced in maximum power and linked with a base station. The highest emission was recorded from analyzer power level (LVL) from the 360 degrees rotation of the turntable and the test antenna raised and lowered over a range from 1 to 4 meters in both horizontally and vertically polarized orientations.
3. Effective Isotropic Radiated Power (EIRP) was measured by substitution method according to TIA/EIA-603-C. The EUT was replaced by dipole antenna (substitution antenna) at same location, and then a known power from S.G. was applied into the dipole antenna through a Tx cable, and then recorded the maximum Analyzer reading through raised and lowered the test antenna. The correction factor (in dB) = S.G. - Tx Cable loss + Substitution antenna gain - Analyzer reading. Then the EUT's EIRP was calculated with the correction factor, $EIRP = LVL + \text{Correction factor}$ and $ERP = EIRP - 2.15$.

3.3.4 Test Setup

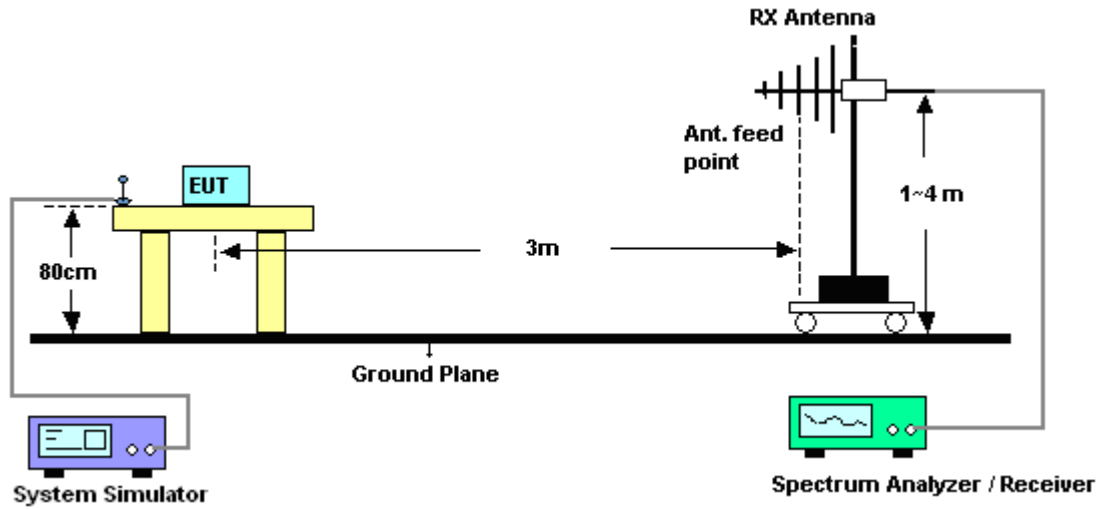

3.3.5 Test Result of EIRP

GSM1900 (GSM) Radiated Power EIRP				
Horizontal Polarization				
Frequency (MHz)	LVL (dBm)	Correction Factor (dB)	EIRP (dBm)	EIRP (W)
1850.2	-14.11	40.70	26.59	0.4560
1880.0	-14.29	41.91	27.62	0.5781
1909.8	-14.53	41.73	27.20	0.5248
Vertical Polarization				
Frequency (MHz)	LVL (dBm)	Correction Factor (dB)	EIRP (dBm)	EIRP (W)
1850.2	-19.24	42.78	23.54	0.2259
1880.0	-19.26	43.75	24.49	0.2812
1909.8	-18.76	43.06	24.30	0.2692

* EIRP = LVL (dBm) + Correction Factor (dB)

WCDMA Band II (RMC 12.2Kbps) Radiated Power EIRP				
Horizontal Polarization				
Frequency (MHz)	LVL (dBm)	Correction Factor (dB)	EIRP (dBm)	EIRP (W)
1852.40	-21.50	40.40	18.90	0.0776
1880.00	-21.96	41.91	19.95	0.0989
1907.60	-22.14	41.59	19.45	0.0881
Vertical Polarization				
Frequency (MHz)	LVL (dBm)	Correction Factor (dB)	EIRP (dBm)	EIRP (W)
1852.40	-27.23	42.69	15.46	0.0352
1880.00	-27.32	43.75	16.43	0.0440
1907.60	-26.98	43.02	16.04	0.0402

* EIRP = LVL (dBm) + Correction Factor (dB)

3.4 Occupied Bandwidth and 26dB Bandwidth Measurement

3.4.1 Description of Occupied Bandwidth and 26dB Bandwidth Measurement

The occupied bandwidth is the width of a frequency band such that, below the lower and above the upper frequency limits, the mean powers emitted are each equal to a specified percentage 0.5% of the total mean transmitted power.

The emission bandwidth is defined as the width of the signal between two points, located at the 2 sides of the carrier frequency, outside of which all emissions are attenuated at least 26 dB below the transmitter power.

3.4.2 Measuring Instruments

See list of measuring instruments of this test report.

3.4.3 Test Procedures

1. The EUT was connected to Spectrum Analyzer and Base Station via power divider.
2. The 99% occupied bandwidth and 26 dB bandwidth of the middle channel for the highest RF powers were measured.

3.4.4 Test Setup

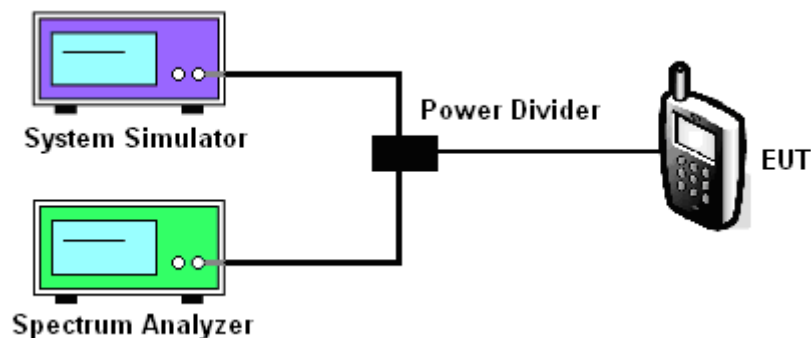



3.4.5 Test Result of Occupied Bandwidth and 26dB Bandwidth

PCS Band			
Modes	GSM1900 (GSM)		
Channel	512 (Low)	661 (Mid)	810 (High)
Frequency (MHz)	1850.2	1880	1909.8
99% OBW (KHz)	244.00	240.00	242.00
26dB BW (KHz)	296.00	302.00	300.00

PCS Band			
Modes	WCDMA Band II (RMC 12.2Kbps)		
Channel	9262 (Low)	9400 (Mid)	9538 (High)
Frequency (MHz)	1852.4	1880	1907.6
99% OBW (MHz)	4.22	4.22	4.24
26dB BW (MHz)	4.96	4.92	4.94

3.4.6 Test Result (Plots) of Occupied Bandwidth and 26dB Bandwidth

Band :	GSM 1900	Test Mode :	GSM Link
--------	----------	-------------	----------

99% Occupied Bandwidth Plot on Channel 512 (1850.2 MHz)

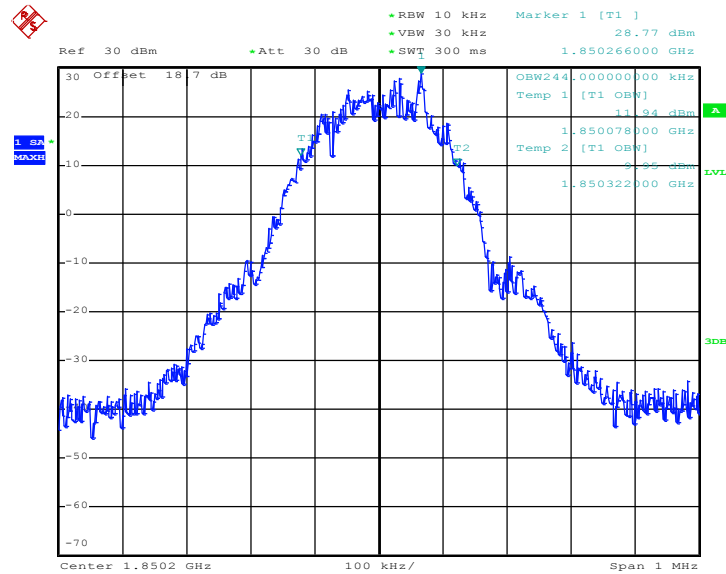

Date: 16.OCT.2012 14:05:47

Note:

The total loss is 18.7dB of the RF cable and attenuator, and has been compensated to the spectrum analyzer by setting into the amplitude level offset. That means the measured result shown on the spectrum analyzer has added the total loss and been compliance with the limit line.



26dB Bandwidth Plot on Channel 512 (1850.2 MHz)

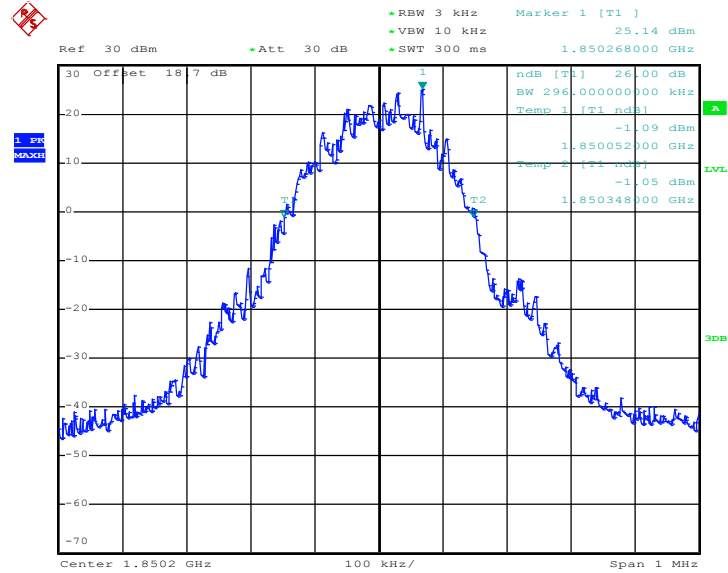

Date: 16.OCT.2012 14:04:29

Note:

The total loss is 18.7dB of the RF cable and attenuator, and has been compensated to the spectrum analyzer by setting into the amplitude level offset. That means the measured result shown on the spectrum analyzer has added the total loss and been compliance with the limit line.



99% Occupied Bandwidth Plot on Channel 661 (1880.0 MHz)

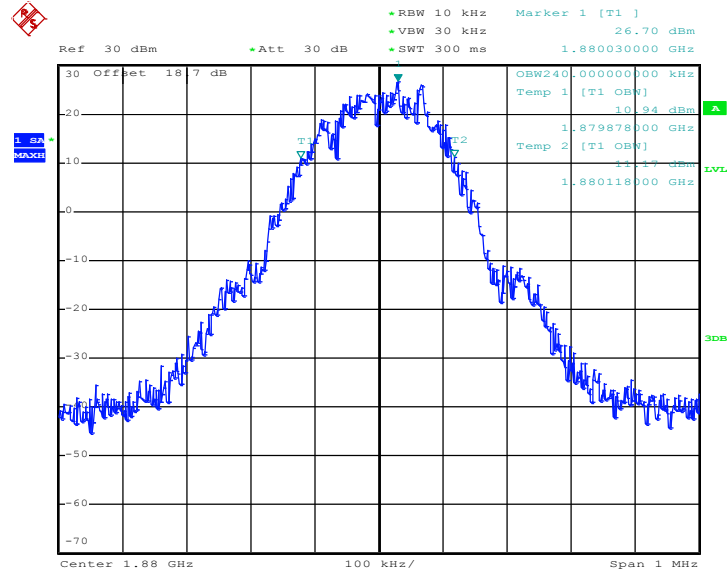

Date: 16.OCT.2012 14:06:13

Note:

The total loss is 18.7dB of the RF cable and attenuator, and has been compensated to the spectrum analyzer by setting into the amplitude level offset. That means the measured result shown on the spectrum analyzer has added the total loss and been compliance with the limit line.



26dB Bandwidth Plot on Channel 661 (1880.0 MHz)

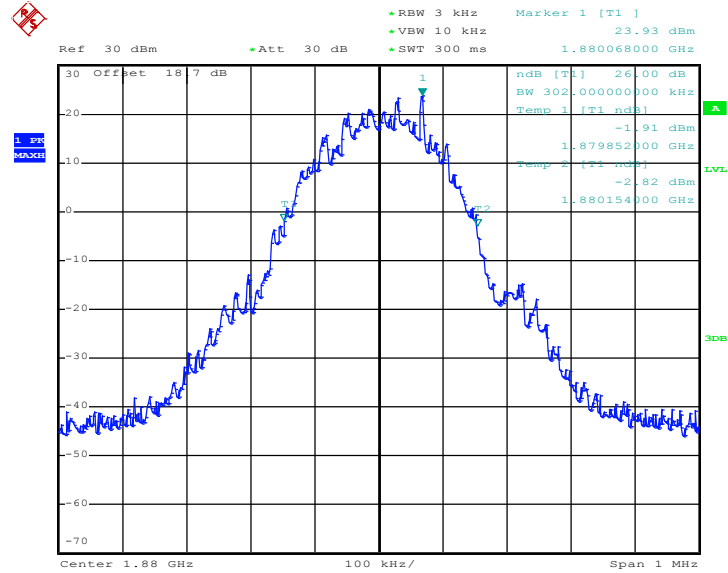

Date: 16.OCT.2012 14:04:55

Note:

The total loss is 18.7dB of the RF cable and attenuator, and has been compensated to the spectrum analyzer by setting into the amplitude level offset. That means the measured result shown on the spectrum analyzer has added the total loss and been compliance with the limit line.



99% Occupied Bandwidth Plot on Channel 810 (1909.8 MHz)

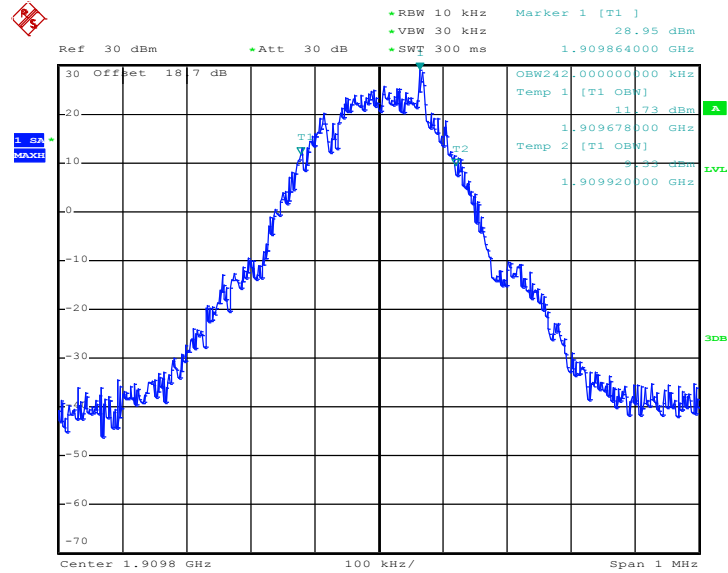

Date: 16.OCT.2012 14:06:39

Note:

The total loss is 18.7dB of the RF cable and attenuator, and has been compensated to the spectrum analyzer by setting into the amplitude level offset. That means the measured result shown on the spectrum analyzer has added the total loss and been compliance with the limit line.



Band :	WCDMA Band II	Test Mode :	RMC 12.2Kbps Link
--------	---------------	-------------	-------------------

99% Occupied Bandwidth Plot on Channel 9262 (1852.4 MHz)

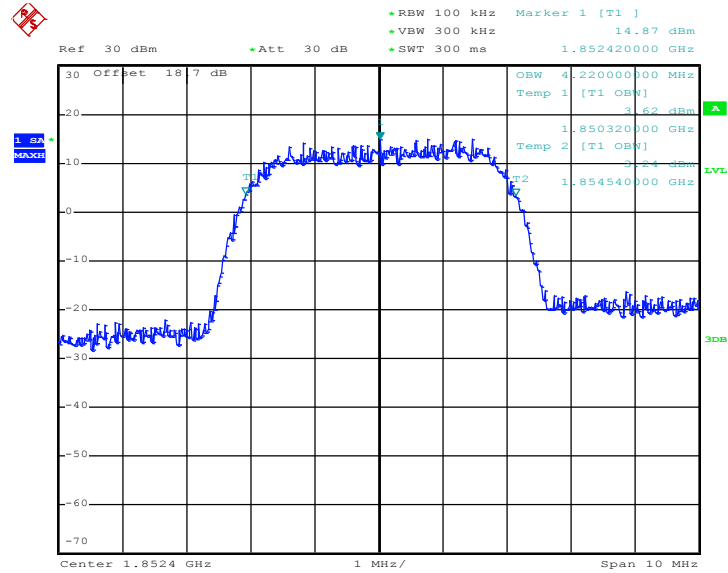

Date: 16.OCT.2012 14:28:46

Note:

The total loss is 18.7dB of the RF cable and attenuator, and has been compensated to the spectrum analyzer by setting into the amplitude level offset. That means the measured result shown on the spectrum analyzer has added the total loss and been compliance with the limit line.



26dB Bandwidth Plot on Channel 9400 (1880.0 MHz)

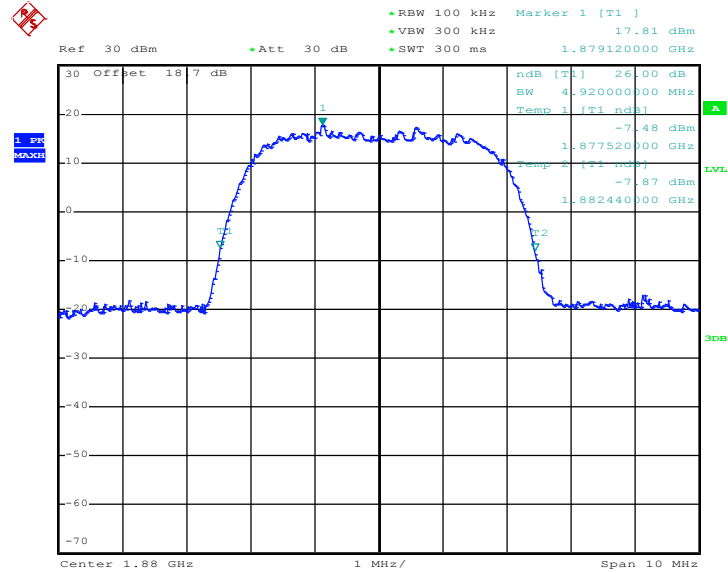

Date: 16.OCT.2012 14:46:20

Note:

The total loss is 18.7dB of the RF cable and attenuator, and has been compensated to the spectrum analyzer by setting into the amplitude level offset. That means the measured result shown on the spectrum analyzer has added the total loss and been compliance with the limit line.



99% Occupied Bandwidth Plot on Channel 9538 (1907.6 MHz)

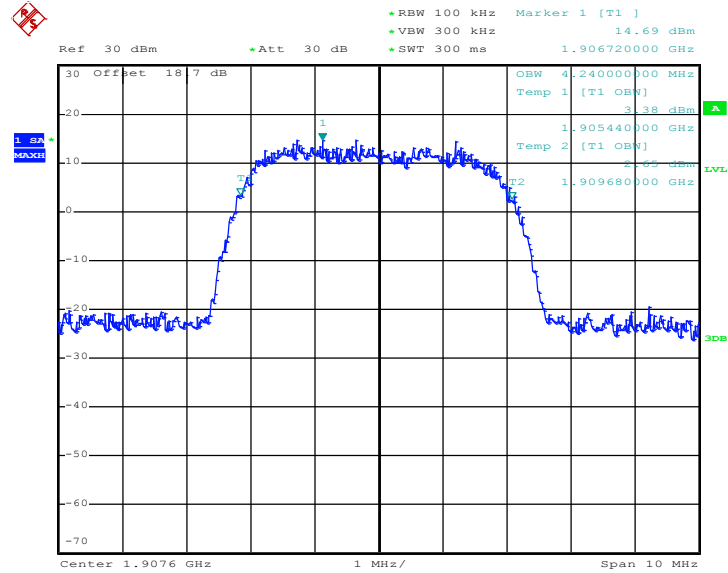

Date: 16.OCT.2012 14:29:38

Note:

The total loss is 18.7dB of the RF cable and attenuator, and has been compensated to the spectrum analyzer by setting into the amplitude level offset. That means the measured result shown on the spectrum analyzer has added the total loss and been compliance with the limit line.



26dB Bandwidth Plot on Channel 9538 (1907.6 MHz)

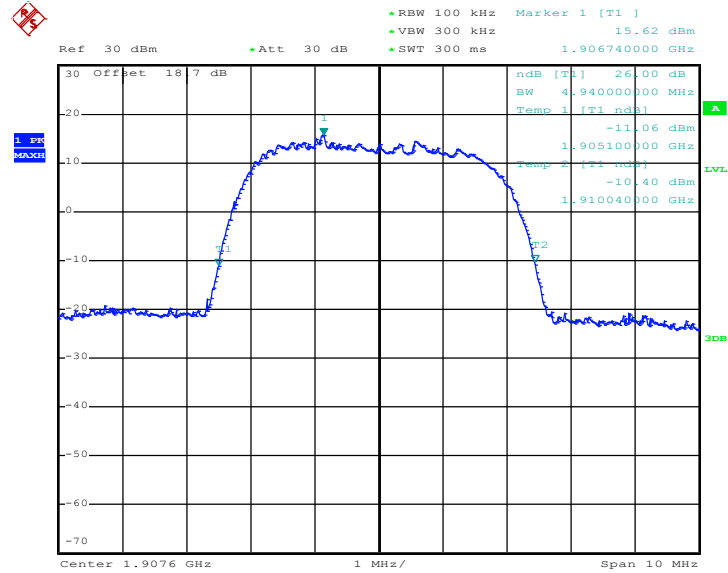

Date: 16.OCT.2012 14:46:47

Note:

The total loss is 18.7dB of the RF cable and attenuator, and has been compensated to the spectrum analyzer by setting into the amplitude level offset. That means the measured result shown on the spectrum analyzer has added the total loss and been compliance with the limit line.

3.5 Band Edge Measurement

3.5.1 Description of Band Edge Measurement

The power of any emission outside of the authorized operating frequency ranges must be lower than the transmitter power (P) by a factor of at least $43 + 10 \log (P)$ dB.

3.5.2 Measuring Instruments

See list of measuring instruments of this test report.

3.5.3 Test Procedures

1. The EUT was connected to Spectrum Analyzer and Base Station via power divider.
2. The band edges of low and high channels for the highest RF powers were measured. Setting RBW as roughly $BW/100$.

3.5.4 Test Setup

<Conducted Band Edge >

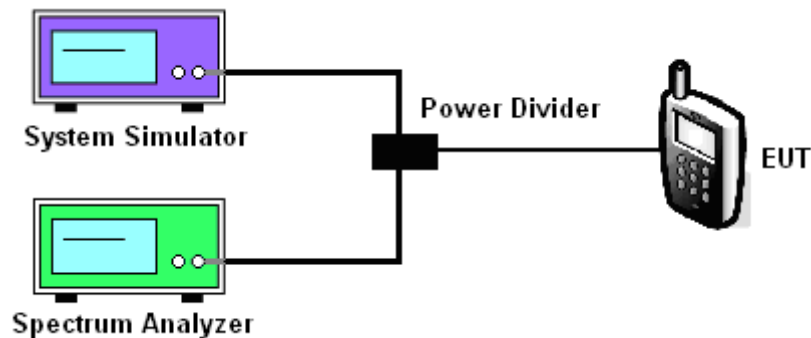

3.5.5 Test Result (Plots) of Conducted Band Edge

Band :	GSM1900	Test Mode :	GSM Link
Correction Factor :	0.03dB	Maximum 26dB Bandwidth :	0.302MHz
Band Edge :	-15.60dBm	Measurement Value :	-15.63dBm

Lower Band Edge Plot on Channel 512 (1850.2 MHz)

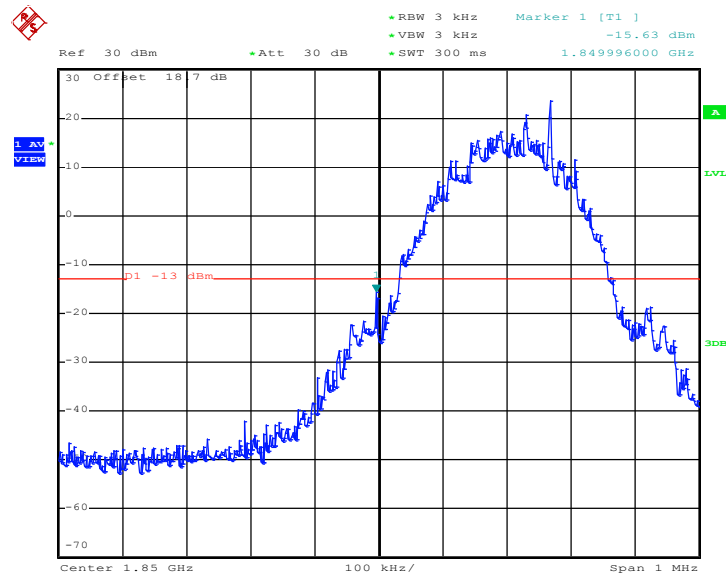

Date: 16.OCT.2012 14:18:30

1. Correction Factor(dB)= $10\log(1\% \text{ Emission BW/RBW})$
2. Band Edge= Measurement Value + Correction Factor(dB)
3. The total loss is 18.7dB of the RF cable and attenuator, and has been compensated to the spectrum analyzer by setting into the amplitude level offset. That means the measured result shown on the spectrum analyzer has added the total loss and been compliance with the limit line.

Band :	GSM1900	Test Mode :	GSM Link
Correction Factor :	0.03dB	Maximum 26dB Bandwidth :	0.302MHz
Band Edge :	-18.26dBm	Measurement Value :	-18.29dBm

Higher Band Edge Plot on Channel 810 (1909.8 MHz)

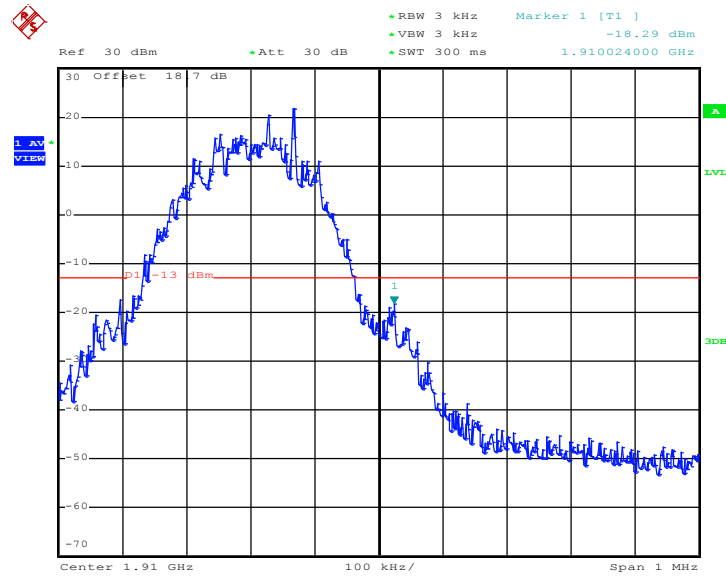

Date: 16.OCT.2012 14:18:56

1. Correction Factor(dB)= $10\log(1\% \text{ Emission BW/RBW})$
2. Band Edge= Measurement Value + Correction Factor(dB)
3. The total loss is 18.7dB of the RF cable and attenuator, and has been compensated to the spectrum analyzer by setting into the amplitude level offset. That means the measured result shown on the spectrum analyzer has added the total loss and been compliance with the limit line.



Band :	WCDMA Band II	Test Mode :	RMC 12.2Kbps Link
Correction Factor :	-3.05dB	Maximum 26dB Bandwidth :	4.96MHz
Band Edge :	-18.37dBm	Measurement Value :	-15.32dBm

Lower Band Edge Plot on Channel 9262 (1852.4 MHz)

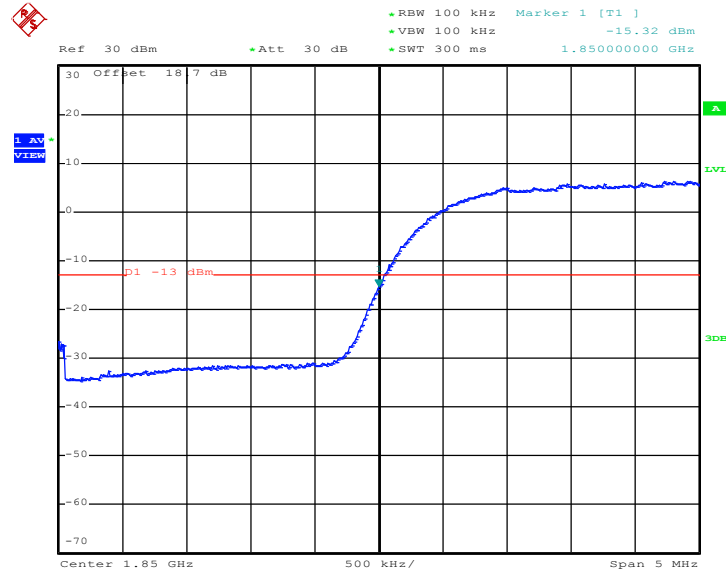

Date: 16.OCT.2012 14:48:32

1. Correction Factor(dB)= $10\log(1\% \text{ Emission BW/RBW})$
2. Band Edge= Measurement Value + Correction Factor(dB)
3. The total loss is 18.7dB of the RF cable and attenuator, and has been compensated to the spectrum analyzer by setting into the amplitude level offset. That means the measured result shown on the spectrum analyzer has added the total loss and been compliance with the limit line.



Band :	WCDMA Band II	Test Mode :	RMC 12.2Kbps Link
Correction Factor :	-3.05dB	Maximum 26dB Bandwidth :	4.96MHz
Band Edge :	-20.57dBm	Measurement Value :	-17.52dBm

Higher Band Edge Plot on Channel 9538 (1907.6 MHz)

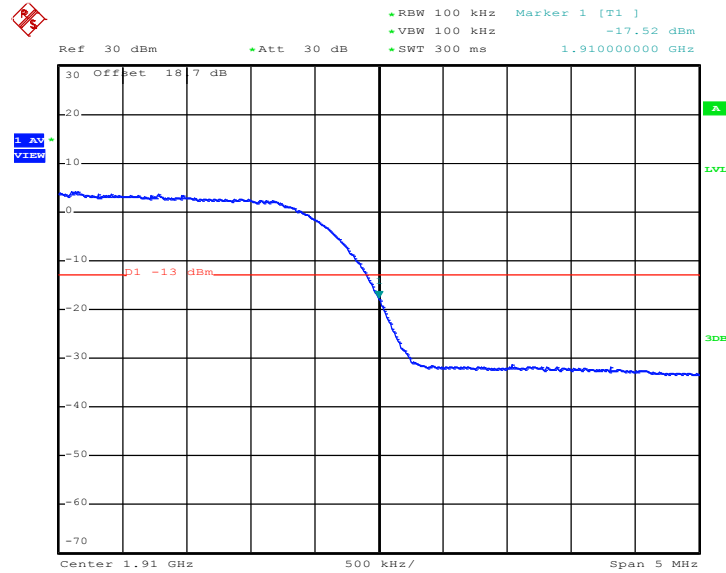

Date: 16.OCT.2012 14:48:59

1. Correction Factor(dB)= $10\log(1\% \text{ Emission BW/RBW})$
2. Band Edge= Measurement Value + Correction Factor(dB)
3. The total loss is 18.7dB of the RF cable and attenuator, and has been compensated to the spectrum analyzer by setting into the amplitude level offset. That means the measured result shown on the spectrum analyzer has added the total loss and been compliance with the limit line.

3.6 Conducted Spurious Emission Measurement

3.6.1 Description of Conducted Spurious Emission Measurement

The power of any emission outside of the authorized operating frequency ranges must be lower than the transmitter power (P) by a factor of at least $43 + 10 \log (P)$ dB.

It is measured by means of a calibrated spectrum analyzer and scanned from 30 MHz up to a frequency including its 10th harmonic.

3.6.2 Measuring Instruments

See list of measuring instruments of this test report.

3.6.3 Test Procedures

1. The EUT was connected to spectrum analyzer and base station via power divider.
2. The middle channel for the highest RF power within the transmitting frequency was measured.
3. The conducted spurious emission for the whole frequency range was taken.

3.6.4 Test Setup

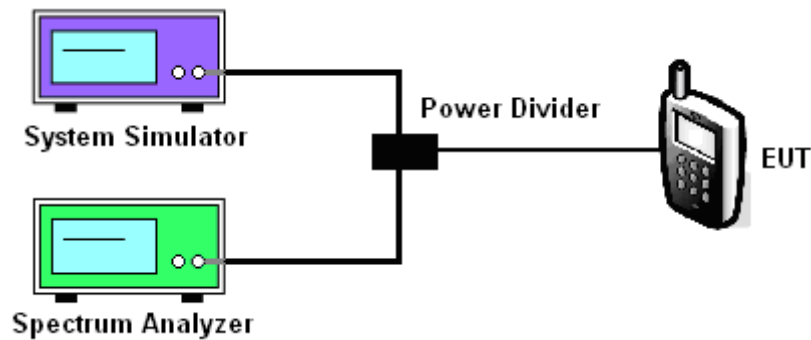

3.6.5 Test Result (Plots) of Conducted Spurious Emission

Band :	GSM1900	Channel :	CH661
Test Mode :	GSM Link	Frequency :	1880.0 MHz

Conducted Spurious Emission Plot between 30MHz ~ 1GHz

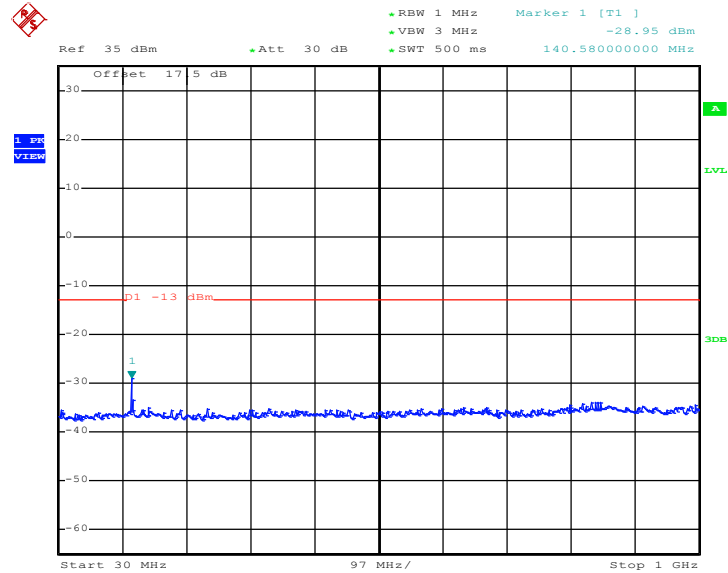

Date: 16.OCT.2012 14:01:44

Note:

The total loss is 17.5dB of the RF cable and attenuator, and has been compensated to the spectrum analyzer by setting into the amplitude level offset. That means the measured result shown on the spectrum analyzer has added the total loss and been compliance with the limit line.



Conducted Spurious Emission Plot between 1GHz ~ 3GHz

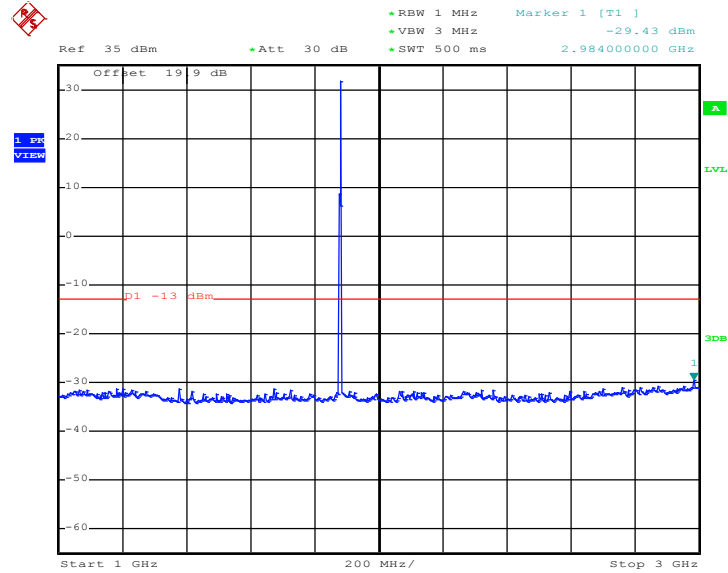

Date: 16.OCT.2012 14:01:57

Note:

The total loss is 19.9dB of the RF cable and attenuator, and has been compensated to the spectrum analyzer by setting into the amplitude level offset. That means the measured result shown on the spectrum analyzer has added the total loss and been compliance with the limit line.



Conducted Spurious Emission Plot between 3GHz ~ 7GHz

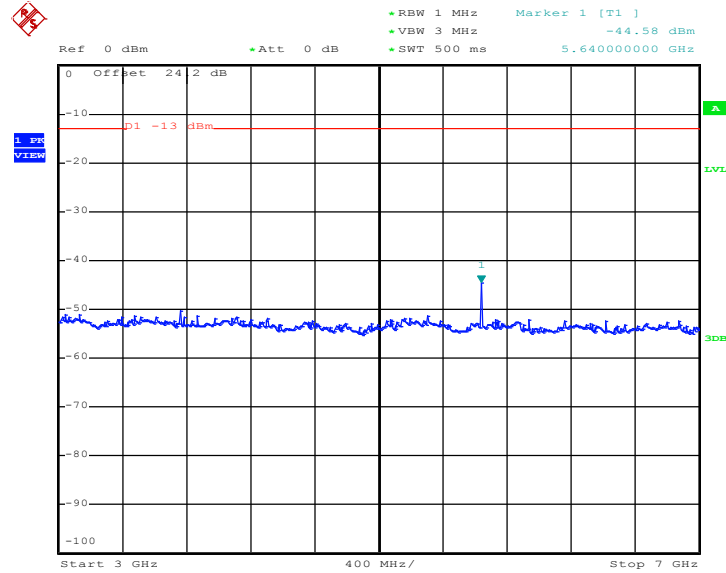

Date: 16.OCT.2012 14:02:22

Note:

The total loss is 24.2dB of the RF cable and attenuator, and has been compensated to the spectrum analyzer by setting into the amplitude level offset. That means the measured result shown on the spectrum analyzer has added the total loss and been compliance with the limit line.



Conducted Emission Plot between 7GHz ~ 13.6GHz

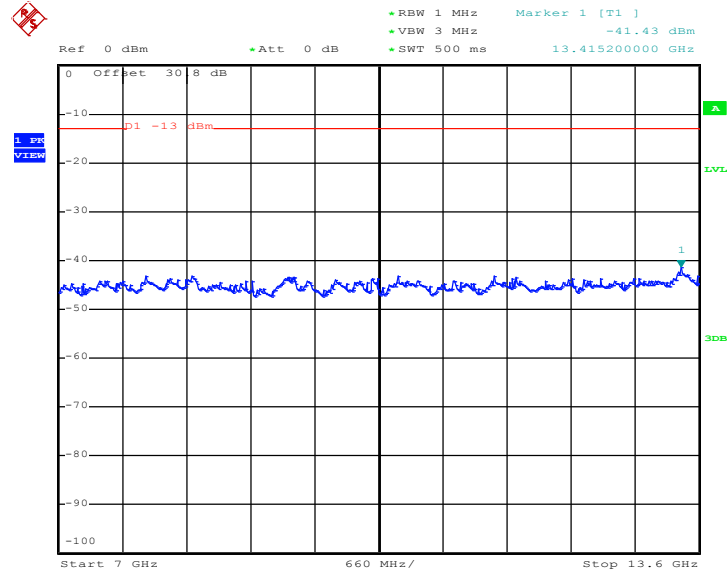

Date: 16.OCT.2012 14:02:35

Note:

The total loss is 30.8dB of the RF cable and attenuator, and has been compensated to the spectrum analyzer by setting into the amplitude level offset. That means the measured result shown on the spectrum analyzer has added the total loss and been compliance with the limit line.



Conducted Spurious Emission Plot between 13.6GHz ~ 19.1GHz

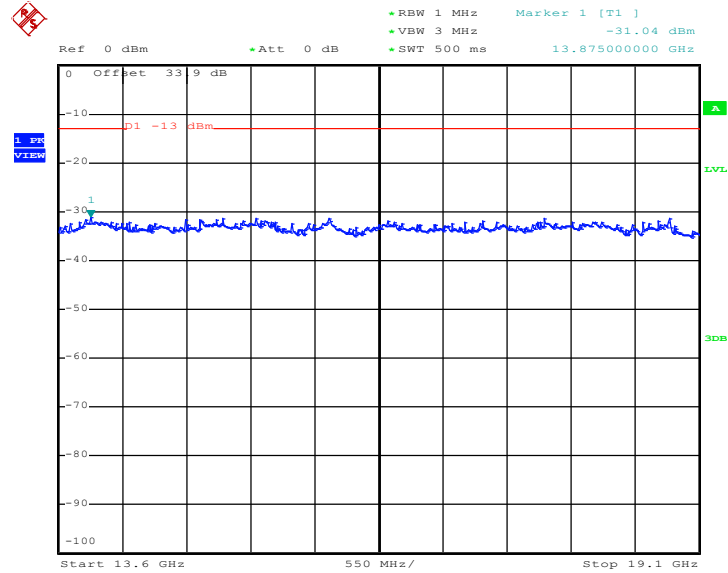

Date: 16.OCT.2012 14:02:47

Note:

The total loss is 33.9dB of the RF cable and attenuator, and has been compensated to the spectrum analyzer by setting into the amplitude level offset. That means the measured result shown on the spectrum analyzer has added the total loss and been compliance with the limit line.



Band :	WCDMA Band II	Channel :	CH9400
Test Mode :	RMC 12.2Kbps Link	Frequency :	1880.0 MHz

Conducted Spurious Emission Plot between 30MHz ~ 1GHz

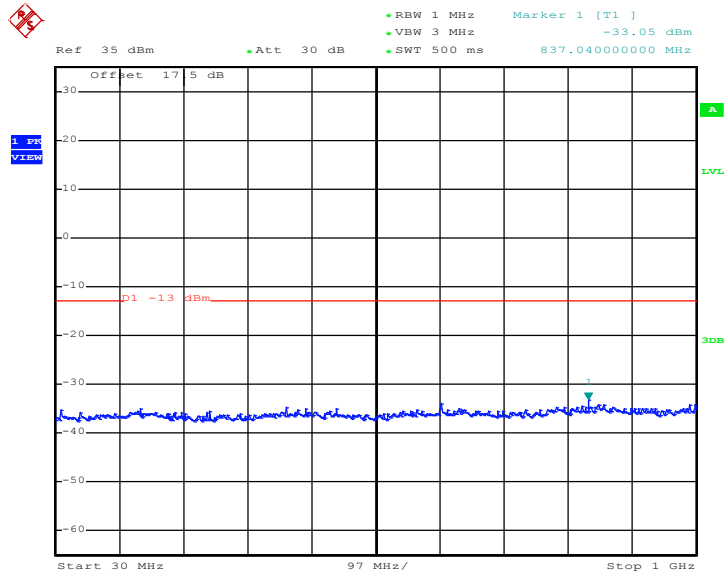

Date: 16.OCT.2012 14:35:15

Note:

The total loss is 17.5dB of the RF cable and attenuator, and has been compensated to the spectrum analyzer by setting into the amplitude level offset. That means the measured result shown on the spectrum analyzer has added the total loss and been compliance with the limit line.



Conducted Spurious Emission Plot between 1GHz ~ 3GHz

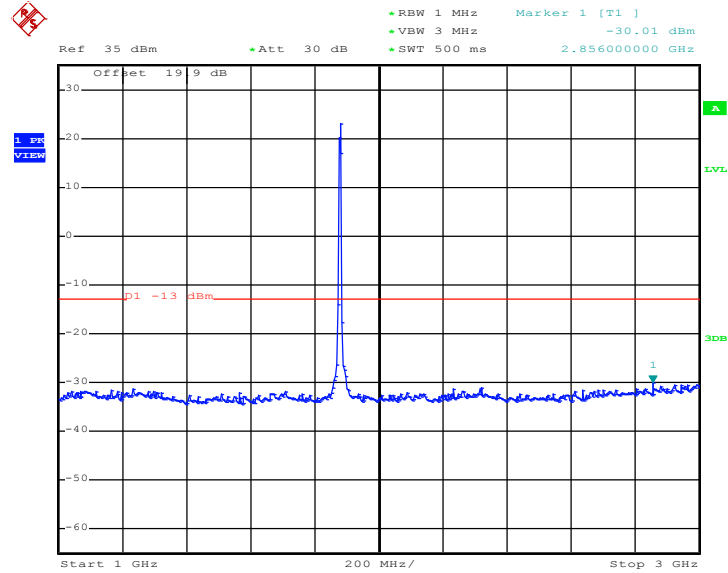

Date: 16.OCT.2012 14:35:28

Note:

The total loss is 19.9dB of the RF cable and attenuator, and has been compensated to the spectrum analyzer by setting into the amplitude level offset. That means the measured result shown on the spectrum analyzer has added the total loss and been compliance with the limit line.



Conducted Spurious Emission Plot between 3GHz ~ 7GHz

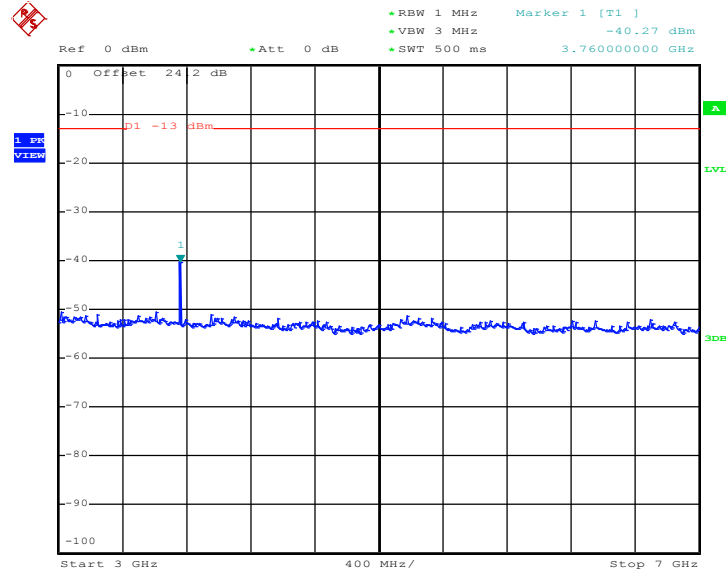

Date: 16.OCT.2012 14:35:45

Note:

The total loss is 24.2dB of the RF cable and attenuator, and has been compensated to the spectrum analyzer by setting into the amplitude level offset. That means the measured result shown on the spectrum analyzer has added the total loss and been compliance with the limit line.



Conducted Spurious Emission Plot between 7GHz ~ 13.6GHz

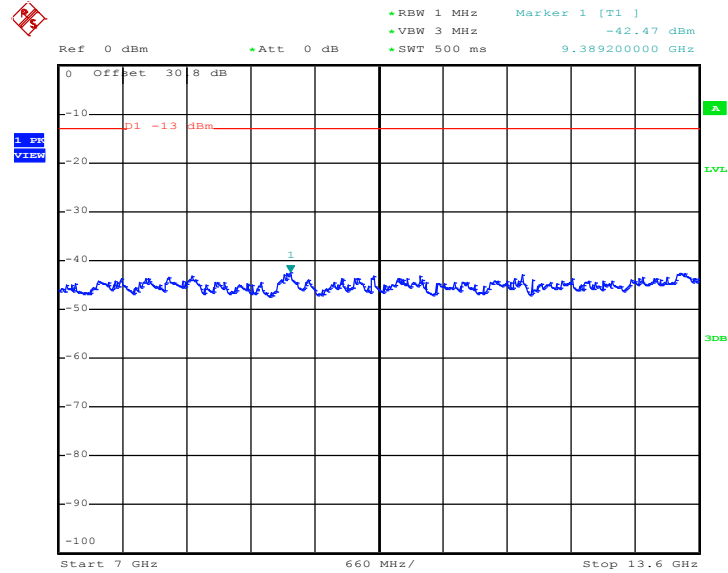

Date: 16.OCT.2012 14:35:57

Note:

The total loss is 30.8dB of the RF cable and attenuator, and has been compensated to the spectrum analyzer by setting into the amplitude level offset. That means the measured result shown on the spectrum analyzer has added the total loss and been compliance with the limit line.



Conducted Spurious Emission Plot between 13.6GHz ~ 19.1GHz

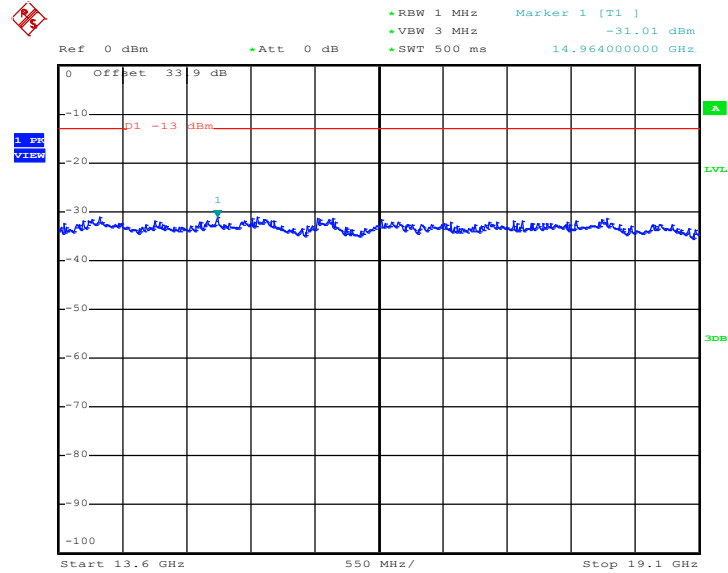

Date: 16.OCT.2012 14:36:10

Note:

The total loss is 33.9dB of the RF cable and attenuator, and has been compensated to the spectrum analyzer by setting into the amplitude level offset. That means the measured result shown on the spectrum analyzer has added the total loss and been compliance with the limit line.

3.7 Field Strength of Spurious Radiation Measurement

3.7.1 Description of Field Strength of Spurious Radiated Measurement

The power of any emission outside of the authorized operating frequency ranges must be attenuated below the transmitter power (P) by a factor of at least $43 + 10 \log (P)$ dB. The spectrum is scanned from 30 MHz up to a frequency including its 10th harmonic.

3.7.2 Measuring Instruments

See list of measuring instruments of this test report.

3.7.3 Test Procedures

1. The EUT was placed on a rotatable wooden table with 0.8 meter above ground.
2. The EUT was set 3 meters from the receiving antenna, which was mounted on the antenna tower.
3. The table was rotated 360 degrees to determine the position of the highest spurious emission.
4. The height of the receiving antenna is varied between one meter and four meters to search the maximum spurious emission for both horizontal and vertical polarizations.
5. Make the measurement with the spectrum analyzer's RBW = 1MHz, VBW = 3MHz, taking the record of maximum spurious emission.
6. A horn antenna was substituted in place of the EUT and was driven by a signal generator.
7. Tune the output power of signal generator to the same emission level with EUT maximum spurious emission.
8. Taking the record of output power at antenna port.
9. Repeat step 7 to step 8 for another polarization.
10. $EIRP \text{ (dBm)} = S.G. \text{ Power} - Tx \text{ Cable Loss} + Tx \text{ Antenna Gain}$
11. $ERP \text{ (dBm)} = EIRP - 2.15$

3.7.4 Test Setup

For radiated emissions below 30MHz

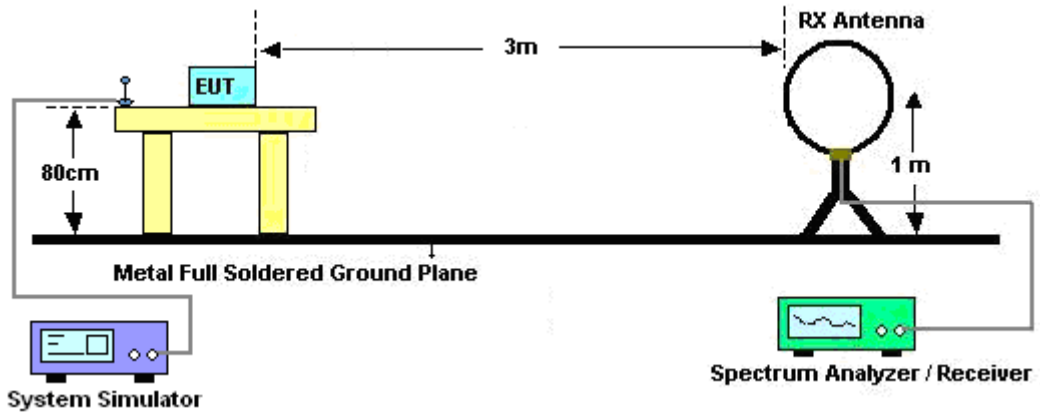

For radiated emissions from 30MHz to 1GHz

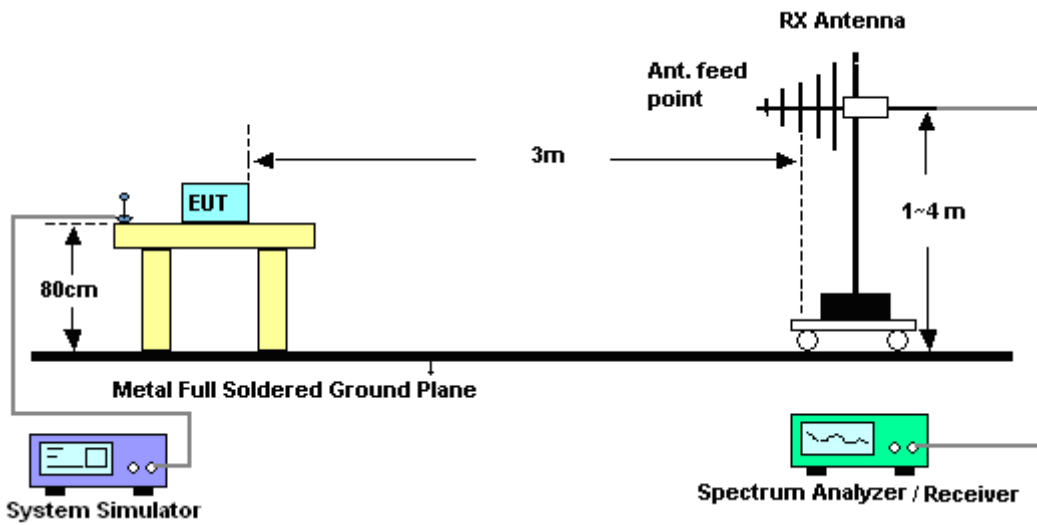

For radiated emissions above 1GHz

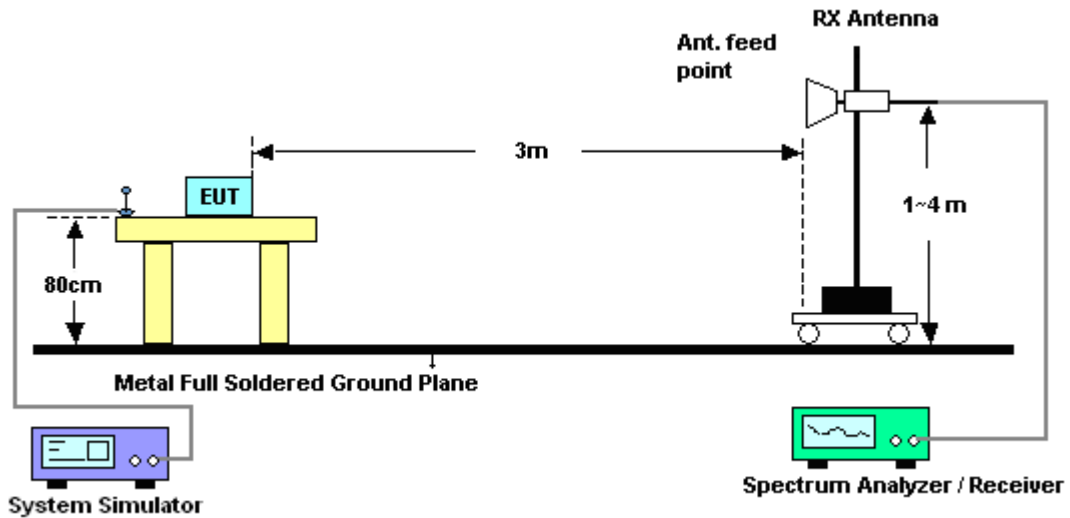

3.7.5 Test Results of Radiated Emissions (9 KHz ~ 30 MHz)

The low frequency, which started from 9 KHz to 30MHz, was pre-scanned and the result which was 20dB lower than the limit line was not reported.



3.7.6 Test Result of Field Strength of Spurious Radiated

Band :	GSM1900	Temperature :	25~26°C
Test Mode :	GSM Link	Relative Humidity :	50~51%
Test Engineer :	Gavin Wu	Polarization :	Horizontal
Remark :	Spurious emissions within 30-1000MHz were found more than 20dB below limit line.		

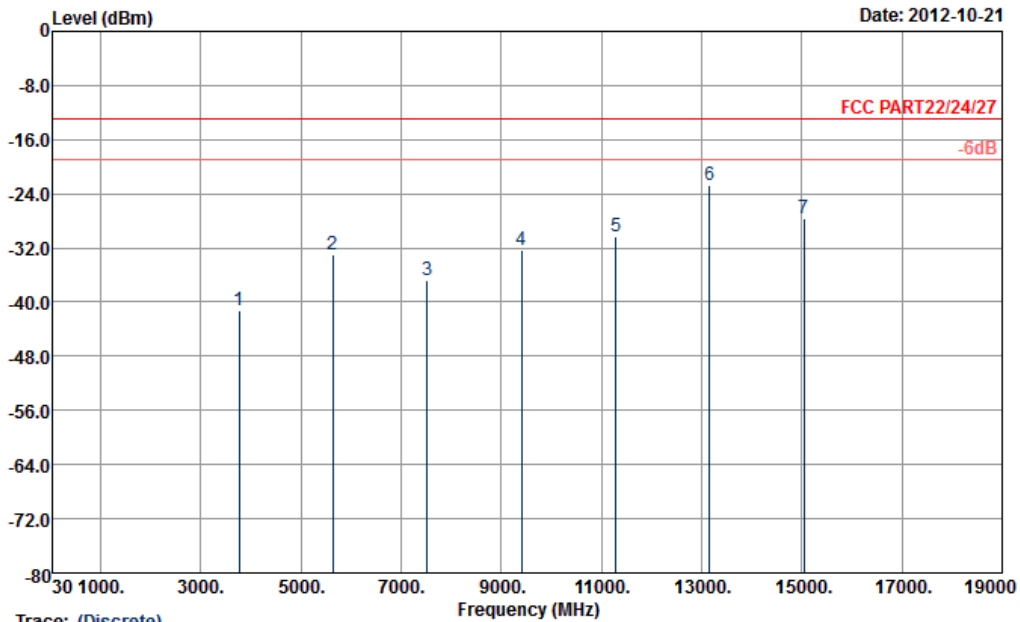

Trace: (Discrete)
 Site : 03CH07-HY
 Condition : FCC PART22/24/27 HF-EIRP(080306) HORIZONTAL
 Project : FG 200922

Frequency (MHz)	EIRP (dBm)	Limit (dBm)	Over Limit (dB)	SPA Reading (dBm)	S.G. Power (dBm)	TX Cable loss (dB)	TX Antenna Gain (dBi)	Polarization (H/V)	Result
3760	-41.15	-13	-28.15	-57.45	-47.45	2.51	8.81	H	Pass
5636	-33.06	-13	-20.06	-55.25	-40.77	2.99	10.70	H	Pass
7520	-36.72	-13	-23.72	-64.89	-45.25	3.59	12.12	H	Pass
9400	-32.34	-13	-19.34	-60.16	-41.44	4.1	13.20	H	Pass
11280	-30.21	-13	-17.21	-60.46	-39.25	4.27	13.31	H	Pass
13160	-22.70	-13	-9.70	-56.49	-32.22	4.27	13.79	H	Pass
15040	-27.59	-13	-14.59	-62.5	-36.56	4.75	13.72	H	Pass



Band :	GSM1900	Temperature :	25~26°C
Test Mode :	GSM Link	Relative Humidity :	50~51%
Test Engineer :	Gavin Wu	Polarization :	Vertical
Remark :	Spurious emissions within 30-1000MHz were found more than 20dB below limit line.		

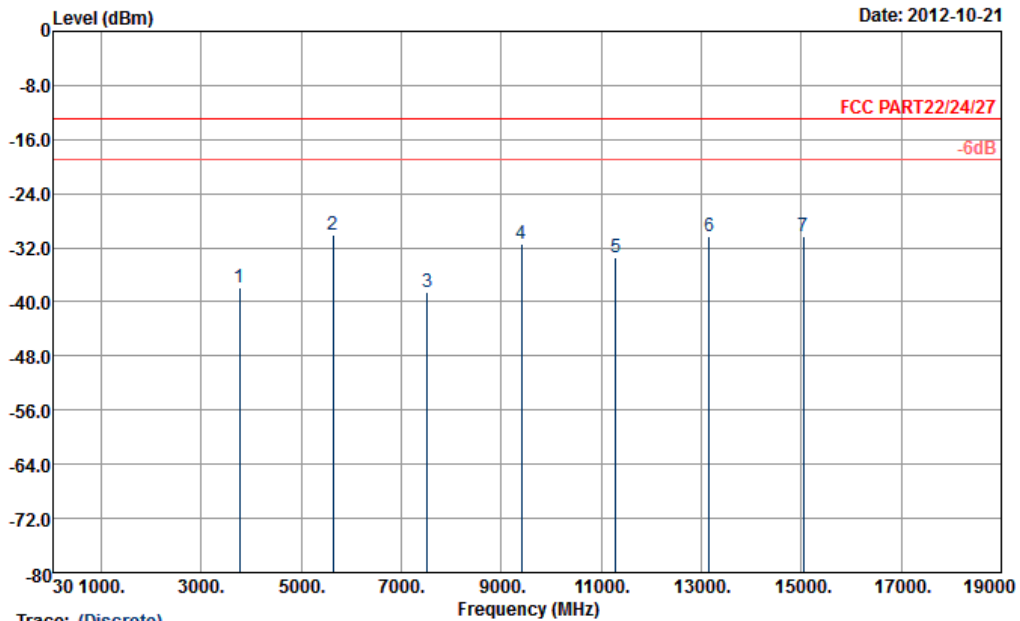

Trace: (Discrete)
 Site : 03CH07-HY
 Condition : FCC PART22/24/27 HF-EIRP(080306) VERTICAL
 Project : FG 200922

Frequency (MHz)	EIRP (dBm)	Limit (dBm)	Over Limit (dB)	SPA Reading (dBm)	S.G. Power (dBm)	TX Cable loss (dB)	TX Antenna Gain (dBi)	Polarization (H/V)	Result
3760	-37.95	-13	-24.95	-54.88	-44.25	2.51	8.81	V	Pass
5636	-30.06	-13	-17.06	-51.89	-37.77	2.99	10.70	V	Pass
7520	-38.61	-13	-25.61	-66.53	-47.14	3.59	12.12	V	Pass
9396	-31.45	-13	-18.45	-58.6	-40.55	4.1	13.20	V	Pass
11280	-33.52	-13	-20.52	-64.46	-42.56	4.27	13.31	V	Pass
13160	-30.26	-13	-17.26	-62.88	-39.78	4.27	13.79	V	Pass
15040	-30.25	-13	-17.25	-63.61	-39.22	4.75	13.72	V	Pass



Band :	WCDMA Band II	Temperature :	25~26°C
Test Mode :	RMC 12.2Kbps Link	Relative Humidity :	50~51%
Test Engineer :	Gavin Wu	Polarization :	Horizontal
Remark :	Spurious emissions within 30-1000MHz were found more than 20dB below limit line.		

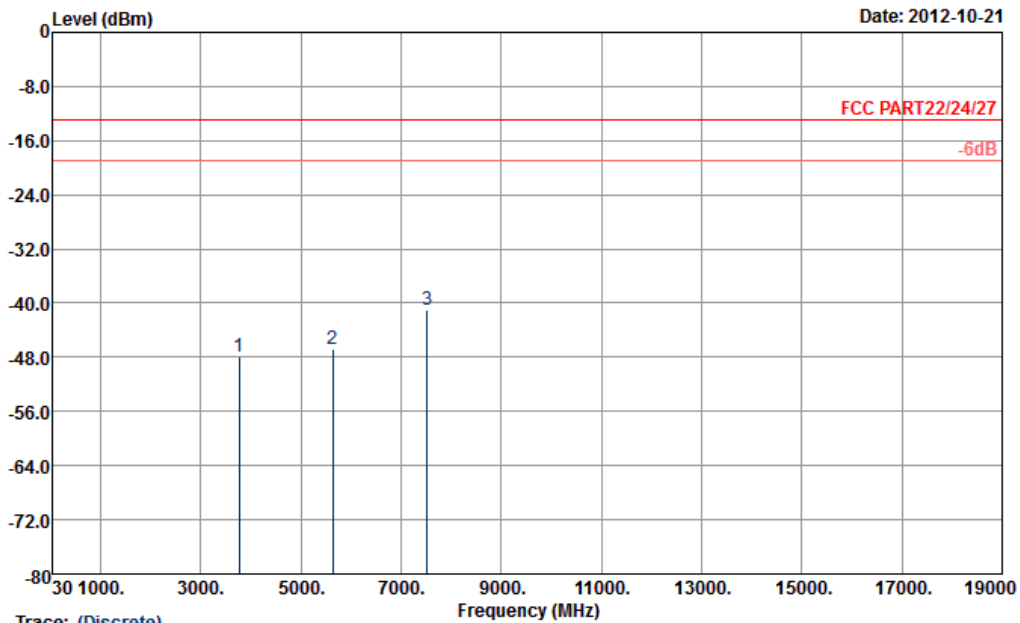

Trace: (Discrete)
 Site : 03CH07-HY
 Condition : FCC PART22/24/27 HF-EIRP(080306) HORIZONTAL
 Project : FG 200922

Frequency (MHz)	EIRP (dBm)	Limit (dBm)	Over Limit (dB)	SPA Reading (dBm)	S.G. Power (dBm)	TX Cable loss (dB)	TX Antenna Gain (dBi)	Polarization (H/V)	Result
3760	-47.95	-13	-34.95	-63.91	-54.25	2.51	8.81	H	Pass
5636	-46.76	-13	-33.76	-68.44	-54.47	2.99	10.70	H	Pass
7520	-40.94	-13	-27.94	-68.39	-49.47	3.59	12.12	H	Pass



Band :	WCDMA Band II	Temperature :	25~26°C
Test Mode :	RMC 12.2Kbps Link	Relative Humidity :	50~51%
Test Engineer :	Gavin Wu	Polarization :	Vertical
Remark :	Spurious emissions within 30-1000MHz were found more than 20dB below limit line.		

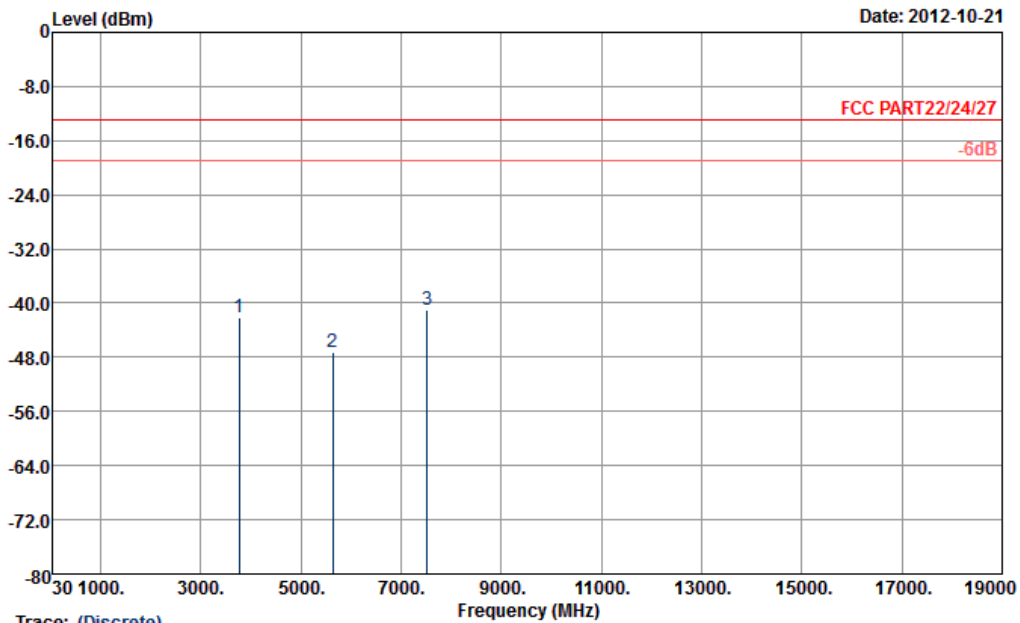

Trace: (Discrete)
 Site : 03CH07-HY
 Condition : FCC PART22/24/27 HF-EIRP(080306) VERTICAL
 Project : FG 200922

Frequency (MHz)	EIRP (dBm)	Limit (dBm)	Over Limit (dB)	SPA Reading (dBm)	S.G. Power (dBm)	TX Cable loss (dB)	TX Antenna Gain (dBi)	Polarization (H/V)	Result
3760	-42.15	-13	-29.15	-59.6	-48.45	2.51	8.81	V	Pass
5636	-47.14	-13	-34.14	-69.28	-54.85	2.99	10.70	V	Pass
7520	-40.92	-13	-27.92	-68.46	-49.45	3.59	12.12	V	Pass

3.8 Frequency Stability Measurement

3.8.1 Description of Frequency Stability Measurement

The frequency stability shall be measured by variation of ambient temperature and variation of primary supply voltage to ensure that the fundamental emission stays within the authorized frequency block. The frequency stability of the transmitter shall be maintained within $\pm 0.00025\%$ ($\pm 2.5\text{ppm}$) of the center frequency.

3.8.2 Measuring Instruments

See list of measuring instruments of this test report.

3.8.3 Test Procedures for Temperature Variation

1. The EUT was set up in the thermal chamber and connected with the base station.
2. With power OFF, the temperature was decreased to -30°C and the EUT was stabilized before testing. Power was applied and the maximum change in frequency was recorded within one minute.
3. With power OFF, the temperature was raised in 10°C step up to 50°C . The EUT was stabilized at each step for at least half an hour. Power was applied and the maximum frequency change was recorded within one minute.
4. If the EUT cannot be turned on at -30°C , the testing lowest temperature will be raised in 10°C step until the EUT can be turned on.

3.8.4 Test Procedures for Voltage Variation

1. The EUT was placed in a temperature chamber at $25\pm 5^{\circ}\text{C}$ and connected with the base station.
2. The power supply voltage to the EUT was varied from BEP to 115% of the nominal value measured at the input to the EUT.
3. The variation in frequency was measured for the worst case.

3.8.5 Test Setup

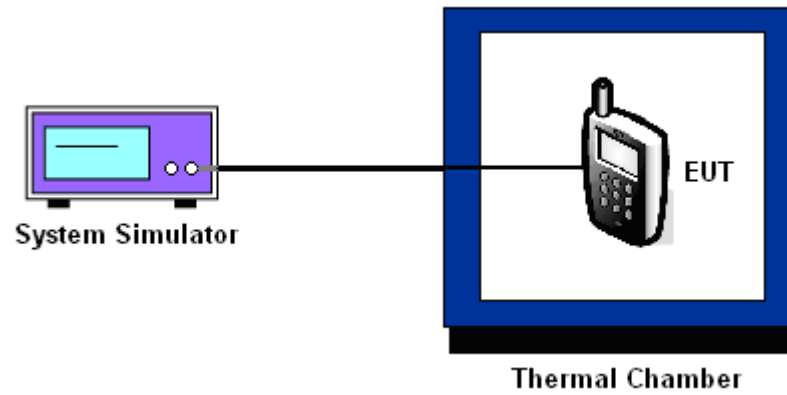



3.8.6 Test Result of Temperature Variation

Band :	GSM 1900	Channel :	661
Limit (ppm) :	2.5	Frequency :	1880.0 MHz

Temperature (°C)	GSM		Result
	Freq. Dev. (Hz)	Deviation (ppm)	
-30	-73	-0.04	PASS
-20	-63	-0.03	
-10	-62	-0.03	
0	-88	-0.05	
10	-62	-0.03	
20	-75	-0.04	
30	-76	-0.04	
40	-65	-0.03	
50	-74	-0.04	

Band :	WCDMA Band II	Channel :	9400
Limit (ppm) :	2.5	Frequency :	1880.0 MHz

Temperature (°C)	RMC 12.2Kbps		Result
	Freq. Dev. (Hz)	Deviation (ppm)	
-30	13	0.01	PASS
-20	15	0.01	
-10	12	0.01	
0	10	0.01	
10	13	0.01	
20	14	0.01	
30	11	0.01	
40	11	0.01	
50	-13	-0.01	



3.8.7 Test Result of Voltage Variation

Band & Channel	Mode	Voltage (Volt)	Freq. Dev. (Hz)	Deviation (ppm)	Limit (ppm)	Result
GSM 1900 CH661	GSM	3.8	-90	-0.05	2.5	PASS
		BEP	-91	-0.05		
		4.35	-88	-0.05		
WCDMA Band II CH9400	RMC 12.2Kbps	3.8	-9	0.00		
		BEP	10	0.01		
		4.35	12	0.01		

Note:

- 1. Normal Voltage = 3.8V.
- 2. Battery End Point (BEP) = 3.6 V.



4 List of Measuring Equipment

Instrument	Manufacturer	Model No.	Serial No.	Characteristics	Calibration Date	Test Date	Due Date	Remark
System Simulator	R&S	CMU200	117995	N/A	Jul. 30, 2012	Oct. 16, 2012	Jul. 29, 2013	Conducted (TH02-HY)
Spectrum Analyzer	R&S	FSP40	100055	9kHz~40GHz	Jun. 06, 2012	Oct. 16, 2012	Jun. 05, 2013	Conducted (TH02-HY)
Thermal Chamber	Ten Billion	TTH-D3SP	TBN-930701	N/A	Jul. 23, 2012	Oct. 16, 2012	Jul. 22, 2013	Conducted (TH02-HY)
Bilog Antenna	SCHAFFNER	CBL6111C	2726	30MHz ~ 1GHz	Oct. 06, 2012	Oct. 21, 2012~ Oct. 25, 2012	Oct. 05, 2013	Radiation (03CH07-HY)
Spectrum Analyzer	R&S	FSP30	101067	9KHz ~ 30GHz	Dec. 06, 2011	Oct. 21, 2012~ Oct. 25, 2012	Dec. 05, 2012	Radiation (03CH07-HY)
Double Ridge Horn Antenna	EMCO	3117	00066583	1GHz ~ 18GHz	Aug. 01, 2012	Oct. 21, 2012~ Oct. 25, 2012	Jul. 31, 2013	Radiation (03CH07-HY)
Pre Amplifier	Agilent	8449B	3008A02362	1GHz ~ 26.5GHz	Dec. 05, 2011	Oct. 21, 2012~ Oct. 25, 2012	Dec. 04, 2012	Radiation (03CH07-HY)
Pre Amplifier	COM-POWER	PA-103A	161241	10-1000MHz.32dB. GAIN	Feb. 27, 2012	Oct. 21, 2012~ Oct. 25, 2012	Feb. 26, 2013	Radiation (03CH07-HY)
Signal Analyzer	Rohde & Schwarz	FSQ	200578/026	20Hz~26.5GHz	Feb. 06, 2012	Oct. 21, 2012~ Oct. 25, 2012	Feb. 05, 2013	Radiation (03CH07-HY)
Pre Amplifier	MITEQ	AMF-7D-00 101800-30-1	159088	1GHz ~ 18GHz	Mar. 10, 2012	Oct. 21, 2012~ Oct. 25, 2012	Mar. 09, 2013	Radiation (03CH07-HY)
SHF-EHF Horn Antenna	SCHWARZBECK	BBHA 9170	BBHA917025 1	15GHz ~ 40GHz	Sep. 28, 2012	Oct. 21, 2012~ Oct. 25, 2012	Sep. 27, 2013	Radiation (03CH07-HY)
Loop Antenna	R&S	HFH2-Z2	100315	9KHz ~ 30MHz	May 14, 2012	Oct. 21, 2012~ Oct. 25, 2012	May 13, 2013	Radiation (03CH07-HY)
System Simulator	R&S	CMU200	117591	N/A	Oct. 21, 2011	Oct. 21, 2012~ Oct. 25, 2012	Oct. 20, 2013	Radiation (03CH07-HY)



5 Uncertainty of Evaluation

Uncertainty of Radiated Emission Measurement (30 MHz ~ 1000 MHz)

Measuring Uncertainty for a Level of Confidence of 95% (U = 2Uc(y))	2.54
---	------

Uncertainty of Radiated Emission Measurement (1 GHz ~ 40 GHz)

Measuring Uncertainty for a Level of Confidence of 95% (U = 2Uc(y))	4.72
---	------