



# PCTEST ENGINEERING LABORATORY, INC.

6660-B Dobbin Road, Columbia, MD 21045 USA  
Tel. +1.410.290.6652 / Fax +1.410.290.6554  
<http://www.pctestlab.com>



## SAR COMPLIANCE EVALUATION REPORT

**Applicant Name:**  
Samsung Electronics, Co. Ltd.  
18600 Broadwick St.  
Rancho Dominguez, CA 90220  
United States

**Date of Testing:**  
02/28/11 - 03/09/11  
**Test Site/Location:**  
PCTEST Lab, Columbia, MD, USA  
**Test Report Serial No.:**  
0Y1102250383.A3L

**FCC ID:** A3LSGHT839

**APPLICANT:** SAMSUNG ELECTRONICS, CO. LTD.

**EUT Type:** 850/1900 GSM/GPRS/EDGE and 1700 WCDMA/HSPA Phone with Bluetooth and WLAN  
**Application Type:** Certification  
**FCC Rule Part(s):** CFR §2.1093; FCC/OET Bulletin 65 Supplement C [June 2001]  
**Model(s):** SGH-T839  
**Tx Frequency:** 824.20 - 848.80 MHz (GSM 850) / 1850.20 - 1909.80 MHz (GSM 1900)  
1712.4 - 1752.5 MHz (AWS WCDMA)  
2412 - 2462 MHz (WLAN)  
2402 - 2480 MHz (Bluetooth)  
**Conducted Power:** 32.34 dBm GSM 850 / 29.43 dBm GSM 1900  
23.03 dBm UMTS IV  
17.64 dBm 2.4 GHz WLAN  
12.52 dBm Bluetooth  
**Max. SAR Measurement:** 0.14 W/kg GSM 850 Head SAR / 0.96 W/kg GSM 850 Body SAR  
0.18 W/kg GSM 1900 Head SAR / 0.68 W/kg GSM 1900 Body SAR  
0.34 W/kg UMTS IV Head SAR / 0.81 W/kg UMTS IV Body SAR  
0.32 W/kg 2.4 GHz WLAN Head SAR / 0.54 W/kg 2.4 GHz WLAN Body SAR  
0.023 W/kg Bluetooth Body SAR  
**Test Device Serial No.:** Pre-Production [S/N: FI 035 A]

This wireless portable device has been shown to be capable of compliance for localized specific absorption rate (SAR) for uncontrolled environment/general population exposure limits specified in ANSI/IEEE C95.1-1992 and has been tested in accordance with the measurement procedures specified in FCC/OET Bulletin 65 Supplement C (2001), IEEE 1528-2003 and in applicable Industry Canada Radio Standards Specifications (RSS); for North American frequency bands only.

I attest to the accuracy of data. All measurements reported herein were performed by me or were made under my supervision and are correct to the best of my knowledge and belief. I assume full responsibility for the completeness of these measurements and vouch for the qualifications of all persons taking them. Test results reported herein relate only to the item(s) tested.

*PCTEST certifies that no party to this application has been subject to a denial of Federal benefits that includes FCC benefits pursuant to Section 5301 of the Anti-Drug Abuse Act of 1988, 21 U.S.C. 862.*

Randy Ortanez  
President



FCC ID: A3LSGHT839		SAR COMPLIANCE REPORT		Reviewed by: Quality Manager
Filename: 0Y1102250383.A3L	Test Dates: 02/28/11 - 03/09/11	EUT Type: 850/1900 GSM/GPRS/EDGE and 1700 WCDMA/HSPA Phone with Bluetooth and WLAN		Page 1 of 45

# T A B L E O F C O N T E N T S

---

1	INTRODUCTION .....	3
2	TEST SITE LOCATION .....	4
3	SAR MEASUREMENT SETUP .....	5
4	DASY E-FIELD PROBE SYSTEM .....	7
5	PROBE CALIBRATION PROCESS .....	8
6	PHANTOM AND EQUIVALENT TISSUES.....	9
7	DOSIMETRIC ASSESSMENT & PHANTOM SPECS.....	10
8	DEFINITION OF REFERENCE POINTS .....	11
9	TEST CONFIGURATION POSITIONS .....	12
10	FCC RF EXPOSURE LIMITS.....	15
11	FCC 3G MEASUREMENT PROCEDURES.....	16
12	SAR TESTING WITH IEEE 802.11 TRANSMITTERS.....	19
13	SINGLE TX SAR CONSIDERATIONS.....	22
14	SYSTEM VERIFICATION.....	23
15	SAR DATA SUMMARY .....	26
16	FCC MULTI-TX AND ANTENNA SAR CONSIDERATIONS.....	33
17	EQUIPMENT LIST.....	35
18	MEASUREMENT UNCERTAINTIES .....	36
19	CONCLUSION.....	37
20	REFERENCES .....	38
21	SAR TEST SETUP PHOTOGRAPHS.....	40

# 1 INTRODUCTION

The FCC has adopted the guidelines for evaluating the environmental effects of radio frequency (RF) radiation in ET Docket 93-62 on Aug. 6, 1996 to protect the public and workers from the potential hazards of RF emissions due to FCC-regulated portable devices. [1]

The safety limits used for the environmental evaluation measurements are based on the criteria published by the American National Standards Institute (ANSI) for localized specific absorption rate (SAR) in IEEE/ANSI C95.1-1992 Standard for Safety Levels with Respect to Human Exposure to Radio Frequency Electromagnetic Fields, 3 kHz to 300 GHz [3] and Health Canada RF Exposure Guidelines Safety Code 6 [24]. The measurement procedure described in IEEE/ANSI C95.3-2002 Recommended Practice for the Measurement of Potentially Hazardous Electromagnetic Fields - RF and Microwave [4] is used for guidance in measuring the Specific Absorption Rate (SAR) due to the RF radiation exposure from the Equipment Under Test (EUT). These criteria for SAR evaluation are similar to those recommended by the International Committee for Non-Ionizing Radiation Protection (ICNIRP) in Biological Effects and Exposure Criteria for Radiofrequency Electromagnetic Fields,” Report No. Vol 74. SAR is a measure of the rate of energy absorption due to exposure to an RF transmitting source. SAR values have been related to threshold levels for potential biological hazards.

## 1.1 SAR Definition

Specific Absorption Rate is defined as the time derivative (rate) of the incremental energy (dU) absorbed by (dissipated in) an incremental mass (dm) contained in a volume element (dV) of a given density ( $\rho$ ). It is also defined as the rate of RF energy absorption per unit mass at a point in an absorbing body (see Fig. 1-1).

$$SAR = \frac{d}{dt} \left( \frac{dU}{dm} \right) = \frac{d}{dt} \left( \frac{dU}{\rho dV} \right)$$

Figure 1-1  
SAR Mathematical Equation

SAR is expressed in units of Watts per Kilogram (W/kg).

$$SAR = \frac{\sigma \cdot E^2}{\rho}$$

where:

- $\sigma$  = conductivity of the tissue-simulating material (S/m)
- $\rho$  = mass density of the tissue-simulating material ( $\text{kg/m}^3$ )
- E = Total RMS electric field strength (V/m)

NOTE: The primary factors that control rate of energy absorption were found to be the wavelength of the incident field in relation to the dimensions and geometry of the irradiated organism, the orientation of the organism in relation to the polarity of field vectors, the presence of reflecting surfaces, and whether conductive contact is made by the organism with a ground plane.[6]

FCC ID: A3LSGHT839		 PCTEST ENGINEERING LABORATORY, INC.		SAR COMPLIANCE REPORT		Reviewed by: Quality Manager	
Filename:	Test Dates:	EUT Type:		Page 3 of 45			
0Y1102250383.A3L	02/28/11 - 03/09/11	850/1900 GSM/GPRS/EDGE and 1700 WCDMA/HSPA Phone with Bluetooth and WLAN					

## 2 TEST SITE LOCATION

### 2.1 INTRODUCTION

The map at the right shows the location of the PCTEST LABORATORY in Columbia, Maryland. It is in proximity to the FCC Laboratory, the Baltimore-Washington International (BWI) airport, the city of Baltimore and Washington, DC.

These measurement tests were conducted at the PCTEST Engineering Laboratory, Inc. facility in New Concept Business Park, Guilford Industrial Park, Columbia, Maryland. The site address is 6660-B Dobbin Road, Columbia, MD 21045. The test site is one of the highest points in the Columbia area with an elevation of 390 feet above mean sea level. The site coordinates are 39° 11'15" N latitude and 76° 49' 38" W longitude. The facility is 1.5 miles north of the FCC laboratory, and the ambient signal and ambient signal strength are approximately equal to those of the FCC laboratory. There are no FM or TV transmitters within 15 miles of the site. The detailed description of the measurement facility was found to be in compliance with the requirements of § 2.948 according to ANSI C63.4 on January 27, 2006 and Industry Canada.

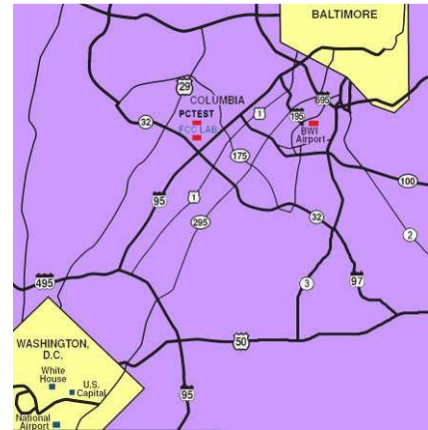

**Figure 2-1**

Map of the Greater Baltimore and Metropolitan Washington, D.C. area

### 2.2 Test Facility / Accreditations:

Measurements were performed at an independent accredited PCTEST Engineering Lab located in Columbia, MD 21045, U.S.A.



- PCTEST Lab is accredited to ISO 17025-2005 by the American Association for Laboratory Accreditation (A2LA) in Specific Absorption Rate (SAR) testing, Hearing-Aid Compatibility (HAC), Battery Safety, CTIA Test Plans, and wireless testing for FCC and Industry Canada Rules.
- PCTEST Lab is accredited to ISO 17025 by U.S. National Institute of Standards and Technology (NIST) under the National Voluntary Laboratory Accreditation Program (NVLAP Lab code: 100431-0) in EMC, FCC and Telecommunications.
- PCTEST facility is an FCC registered (PCTEST Reg. No. 90864) test facility with the site description report on file and has met all the requirements specified in Section 2.948 of the FCC Rules and Industry Canada (IC-2451).
- PCTEST Lab is a recognized U.S. Conformity Assessment Body (CAB) in EMC and R&TTE (n.b. 0982) under the U.S.-EU Mutual Recognition Agreement (MRA).
- PCTEST TCB is a Telecommunication Certification Body (TCB) accredited to ISO/IEC Guide 65 by the American National Standards Institute (ANSI) in all scopes of FCC Rules and all Industry Canada Standards (RSS).
- PCTEST facility is an IC registered (IC-2451) test laboratory with the site description on file at Industry Canada.
- PCTEST is a CTIA Authorized Test Laboratory (CATL) for AMPS and CDMA, and EvDO mobile phones.
- PCTEST is a CTIA Authorized Test Laboratory (CATL) for Over-the-Air (OTA) Antenna Performance testing for AMPS, CDMA, GSM, GPRS, EGPRS, UMTS (W-CDMA), CDMA 1xEVDO Data, CDMA 1xRTT Data

FCC ID: A3LSGHT839		 <b>SAR COMPLIANCE REPORT</b>		Reviewed by: Quality Manager
Filename: 0Y1102250383.A3L	Test Dates: 02/28/11 - 03/09/11	EUT Type: 850/1900 GSM/GPRS/EDGE and 1700 WCDMA/HSPA Phone with Bluetooth and WLAN		Page 4 of 45

## 3 SAR MEASUREMENT SETUP

### 3.1 Robotic System

Measurements are performed using the DASY4 automated dosimetric assessment system. The DASY4 is made by Schmid & Partner Engineering AG (SPEAG) in Zurich, Switzerland and consists of a high precision robotics system (Staubli), robot controller, desktop computer, near-field probe, probe alignment sensor, and the SAM phantom containing the head or body equivalent material. The robot is a six-axis industrial robot, performing precise movements to position the probe to the location (points) of maximum electromagnetic field (EMF) (see Figure 3-1).

### 3.2 System Hardware

A cell controller system contains the power supply, robot controller, teach pendant (Joystick), and a remote control used to drive the robot motors. The PC consists of the SAR Measurement Software DASY4, A/D interface card, monitor, mouse, and keyboard. The Staubli Robot is connected to the cell controller to allow software manipulation of the robot. A data acquisition electronic (DAE) circuit that performs the signal amplification, signal multiplexing, A/D conversion, offset measurements, mechanical surface detection, collision detection, etc. is connected to the Electro-optical coupler (EOC). The EOC performs the conversion from the optical into digital electric signal from the DAE and transfers data to the PC card.

### 3.3 System Electronics

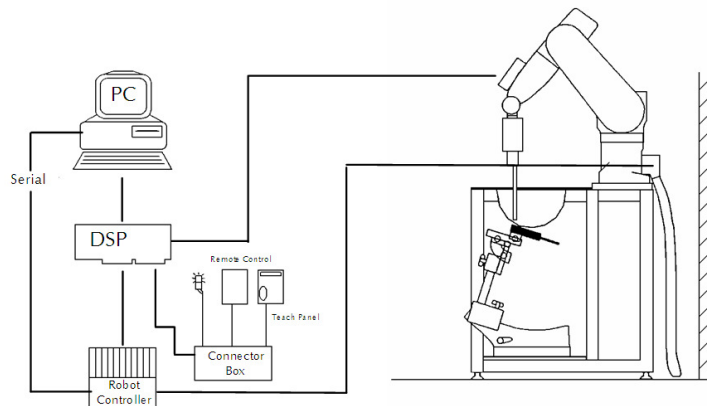

**Figure 3-1**  
**SAR Measurement System Setup**

The DAE consists of a highly sensitive electrometer-grade auto-zeroing preamplifier, a channel and gain-switching multiplexer, a fast 16 bit AD-converter and a command decoder and control logic unit. Transmission to the PC-card is accomplished through an optical downlink for data and status information and an optical uplink for commands and clock lines. The mechanical probe mounting device includes two different sensor systems for frontal and sidewise probe contacts. They are also used for mechanical surface detection and probe collision detection. The robot uses its own controller with a built in VME-bus computer.

FCC ID: A3LSGHT839		 PCTEST ENGINEERING LABORATORY, INC.		SAR COMPLIANCE REPORT		Reviewed by: Quality Manager	
Filename: 0Y1102250383.A3L	Test Dates: 02/28/11 - 03/09/11	EUT Type: 850/1900 GSM/GPRS/EDGE and 1700 WCDMA/HSPA Phone with Bluetooth and WLAN				Page 5 of 45	

### 3.4 Automated Test System Specifications

Test Software: SPEAG DASY4 version 4.7 Measurement Software  
 Robot: Stäubli Unimation Corp. Robot RX60L  
 Repeatability: 0.02 mm  
 No. of Axes: 6

#### Data Acquisition Electronic System (DAE)

#### Data Converter

Features: Signal Amplifier, multiplexer, A/D converter & control logic  
 Software: SEMCAD software  
 Connecting Lines: Optical Downlink for data and status info  
 Optical upload for commands and clock

#### PC Interface Card

Function: Link to DAE  
 16-bit A/D converter for surface detection system  
 Two Serial & Ethernet link to robotics  
 Direct emergency stop output for robot

#### Phantom

Type: SAM Twin Phantom (V4.0)  
 Shell Material: Composite  
 Thickness:  $2.0 \pm 0.2$  mm



**Figure 3-2**  
**SAR Measurement System**

FCC ID: A3LSGHT839		 <b>SAR COMPLIANCE REPORT</b>		Reviewed by: Quality Manager
Filename: 0Y1102250383.A3L	Test Dates: 02/28/11 - 03/09/11	EUT Type: 850/1900 GSM/GPRS/EDGE and 1700 WCDMA/HSPA Phone with Bluetooth and WLAN		Page 6 of 45

### 4.1 Probe Measurement System



**Figure 4-1  
SAR System**

The SAR measurements were conducted with the dosimetric probe designed in the classical triangular configuration (see Figure 4-3) and optimized for dosimetric evaluation [9]. The probe is constructed using the thick film technique; with printed resistive lines on ceramic substrates. The probe is equipped with an optical multi-fiber line ending at the front of the probe tip. It is connected to the EOC box on the robot arm and provides an automatic detection of the phantom surface. Half of the fibers are connected to a pulsed infrared transmitter, the other half to a synchronized receiver. As the probe approaches the surface, the reflection from the surface produces a coupling from the transmitting to the receiving fibers. This reflection increases first during the approach, reaches maximum and then decreases. If the probe is flatly touching the surface, the coupling is zero. The distance of the coupling maximum to the surface is independent of the surface reflectivity and largely independent of the surface to probe angle. The DASY4 software reads the reflection during a software approach and looks for the

maximum using a 2nd order curve fitting (see Figure 5-1). The approach is stopped at reaching the maximum.

### 4.2 Probe Specifications

<b>Model(s):</b>	ES3DV2, ES3DV3, EX3DV4
<b>Frequency Range:</b>	10 MHz – 6.0 GHz (EX3DV4) 10 MHz – 4 GHz (ES3DV3)
<b>Calibration:</b>	In head and body simulating tissue at Frequencies from 300 up to 6000MHz
<b>Linearity:</b>	± 0.2 dB (30 MHz to 6 GHz) for EX3DV4 ± 0.2 dB (30 MHz to 4 GHz) for ES3DV3
<b>Dynamic Range:</b>	10 mW/kg – 100 W/kg
<b>Probe Length:</b>	330 mm
<b>Probe Tip Length:</b>	20 mm
<b>Body Diameter:</b>	12 mm
<b>Tip Diameter:</b>	2.5 mm (3.9mm for ES3DV3)
<b>Tip-Center:</b>	1 mm (2.0 mm for ES3DV3)
<b>Application:</b>	SAR Dosimetry Testing Compliance tests of mobile phones Dosimetry in strong gradient fields



**Figure 4-2  
Near-Field Probe**



**Figure 4-3  
Triangular Probe  
Configuration**

FCC ID: A3LSGHT839				SAR COMPLIANCE REPORT		Reviewed by: Quality Manager	
Filename: 0Y1102250383.A3L	Test Dates: 02/28/11 - 03/09/11	EUT Type: 850/1900 GSM/GPRS/EDGE and 1700 WCDMA/HSPA Phone with Bluetooth and WLAN				Page 7 of 45	

# 5 PROBE CALIBRATION PROCESS

## 5.1 Dosimetric Assessment Procedure

Each E-Probe/Probe Amplifier combination has unique calibration parameters. A TEM cell calibration procedure is conducted to determine the proper amplifier settings to enter in the probe parameters. The amplifier settings are determined for a given frequency by subjecting the probe to a known E-field density (1 mW/cm<sup>2</sup>) using an RF Signal generator, TEM cell, and RF Power Meter.

## 5.2 Free Space Assessment

The free space E-field from amplified probe outputs is determined in a test chamber. This calibration can be performed in a TEM cell if the frequency is below 1 GHz and in a waveguide or other methodologies above 1 GHz for free space. For the free space calibration, the probe is placed in the volumetric center of the cavity and at the proper orientation with the field. The probe is rotated 360 degrees until the three channels show the maximum reading. The power density readings equates to 1 mW/cm<sup>2</sup>.

## 5.3 Temperature Assessment

E-field temperature correlation calibration is performed in a flat phantom filled with the appropriate simulated head tissue. The E-field in the medium correlates with the temperature rise in the dielectric medium. For temperature correlation calibration a RF transparent thermistor-based temperature probe is used in conjunction with the E-field probe.

$$SAR = C \frac{\Delta T}{\Delta t}$$

where:

- $\Delta t$  = exposure time (30 seconds),
- C = heat capacity of tissue (brain or muscle),
- $\Delta T$  = temperature increase due to RF exposure.

$$SAR = \frac{|E|^2 \cdot \sigma}{\rho}$$

where:

- $\sigma$  = simulated tissue conductivity,
- $\rho$  = Tissue density (1.25 g/cm<sup>3</sup> for brain tissue)

SAR is proportional to  $\Delta T/\Delta t$ , the initial rate of tissue heating, before thermal diffusion takes place. The electric field in the simulated tissue can be used to estimate SAR by equating the thermally derived SAR to that with the E- field component.

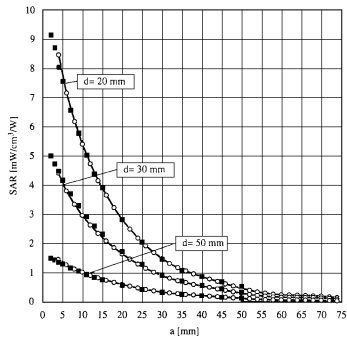

Figure 5-1 E-Field and Temperature measurements at 900MHz [9]

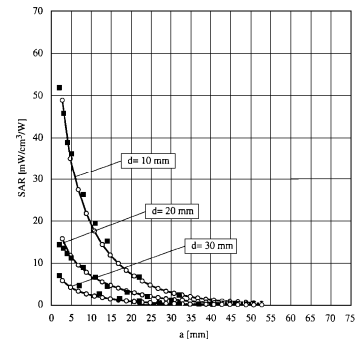



Figure 5-2 E-Field and temperature measurements at 1.9GHz [9]

FCC ID: A3LSGHT839				SAR COMPLIANCE REPORT		Reviewed by: Quality Manager	
Filename: 0Y1102250383.A3L	Test Dates: 02/28/11 - 03/09/11	EUT Type: 850/1900 GSM/GPRS/EDGE and 1700 WCDMA/HSPA Phone with Bluetooth and WLAN				Page 8 of 45	

# 6

# PHANTOM AND EQUIVALENT TISSUES

## 6.1 SAM Phantoms



**Figure 6-1  
SAM Phantoms**

The SAM Twin Phantom V4.0 is constructed of a fiberglass shell integrated in a table. The shape of the shell is based on data from an anatomical study designed to represent the 90<sup>th</sup> percentile of the population [12][13]. The phantom enables the dosimetric evaluation of SAR for both left and right handed handset usage, as well as body-worn usage using the flat phantom region. Reference markings on the Phantom allow the complete setup of all predefined phantom positions and measurement grids by manually teaching three points in the robot. The shell phantom has a 2mm shell thickness (except the ear region where shell thickness increases to 6 mm).

## 6.2 Tissue Simulating Mixture Characterization

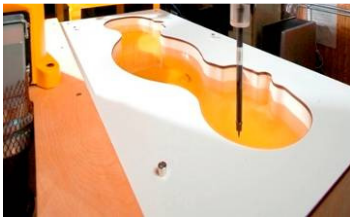

**Figure 6-2  
SAM Phantom with  
Simulating Tissue**

**Table 6-1**  
Composition of the Tissue Equivalent Matter

Frequency (MHz)	835	835	1750	1750	1900	1900	2450	2450
Tissue	Head	Body	Head	Body	Head	Body	Head	Body
Ingredients (% by weight)								
Bactericide	0.1	0.1						
DGBE			47	31	44.92	29.44	7.99	26.7
HEC	1	1						
NaCl	1.45	0.94	0.4	0.2	0.18	0.39	0.16	0.1
Sucrose	57	44.9						
Triton X-100							19.97	
Water	40.45	53.06	52.6	68.8	54.9	70.17	71.88	73.2

FCC ID: A3LSGHT839		<b>SAR COMPLIANCE REPORT</b>	Reviewed by: Quality Manager
--------------------	---	------------------------------	---------------------------------

Filename: 0Y1102250383.A3L	Test Dates: 02/28/11 - 03/09/11	EUT Type: 850/1900 GSM/GPRS/EDGE and 1700 WCDMA/HSPA Phone with Bluetooth and WLAN	Page 9 of 45
-------------------------------	------------------------------------	---	--------------

### 7.1 Measurement Procedure

The evaluation was performed using the following procedure:

1. The SAR distribution at the exposed side of the head was measured at a distance no greater than 5.0 mm from the inner surface of the shell. The area covered the entire dimension of the head and the horizontal grid spacing was 15mm x 15mm.
2. The point SAR measurement was taken at the maximum SAR region determined from Step 1 to enable the monitoring of SAR fluctuations/drifts during testing the 1 gram cube. This fixed point was measured and used as a reference value.
3. Based on the area scan data, the area of the maximum absorption was determined by spline interpolation. Around this point, a volume of 32mm x 32mm x 30mm (fine resolution volume scan, zoom scan) was assessed by measuring 5 x 5 x 7 points. On this basis of this data set, the spatial peak SAR value was evaluated with the following procedure (see references or the DASY manual for more details):
  - a. The data was extrapolated to the surface of the outer-shell of the phantom. The combined distance extrapolated was the combined distance from the center of the dipoles 2.7mm away from the tip of the probe housing plus the 1.2 mm distance between the surface and the lowest measuring point. The extrapolation was based on a least-squares algorithm. A polynomial of the fourth order was calculated through the points in the z-axis (normal to the phantom shell).
  - b. After the maximum interpolated values were calculated between the points in the cube, the SAR was averaged over the spatial volume (1g or 10g) using a 3D-Spline interpolation algorithm. The 3D-spline is composed of three one-dimensional splines with the "Not a knot" condition (in x, y, and z directions). The volume was then integrated with the trapezoidal algorithm. One thousand points (10 x 10 x 10) were obtained through interpolation, in order to calculate the averaged SAR.
  - c. All neighboring volumes were evaluated until no neighboring volume with a higher average value was found.
4. The SAR reference value, at the same location as step 2, was re-measured after the zoom scan was complete. If the value deviated by more than 5%, the evaluation was repeated.
5. For 5 GHz testing finer resolution zoom scans were performed as specified by FCC SAR Measurement Requirements for 3 – 6 GHz, KDB pub 865664. The 5 GHz zoom scan requires a minimum volume of 24mm x 24mm x 20mm and 7 x 7 x 11 points.

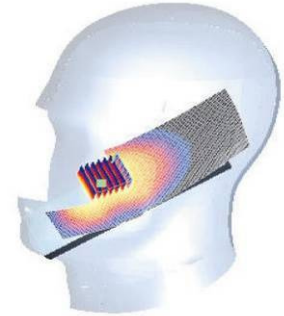

**Figure 7-1**  
Sample SAR Area Scan

### 7.2 Specific Anthropomorphic Mannequin (SAM) Specifications

The phantom for handset SAR assessment testing is a low-loss dielectric shell, with shape and dimensions derived from the anthropometric data of the 90th percentile adult male head dimensions as tabulated by the US Army. The SAM Twin Phantom shell is bisected along the mid-sagittal plane into right and left halves (see Figure 7-2). The perimeter sidewalls of each phantom halves are extended to allow filling with liquid to a depth that is sufficient to minimize reflections from the upper surface. The liquid depth is maintained at a minimum depth of 15 cm.



**Figure 7-2**  
SAM Twin Phantom Shell

FCC ID: A3LSGHT839				SAR COMPLIANCE REPORT		Reviewed by: Quality Manager	
Filename:	Test Dates:	EUT Type:		850/1900 GSM/GPRS/EDGE and 1700 WCDMA/HSPA Phone with Bluetooth and WLAN		Page 10 of 45	
OY1102250383.A3L		02/28/11 - 03/09/11					

### 8.1 EAR REFERENCE POINT

Figure 8-1 shows the front, back and side views of the SAM Twin Phantom. The point “M” is the reference point for the center of the mouth, “LE” is the left ear reference point (ERP), and “RE” is the right ERP. The ERP is 15mm posterior to the entrance to the ear canal (EEC) along the B-M line (Back-Mouth), as shown in Figure 8-1. The plane passing through the two ear canals and M is defined as the Reference Plane. The line N-F (Neck-Front) is perpendicular to the reference plane and passing through the RE (or LE) is called the Reference Pivoting Line (see Figure 8-2

Front, back and side view of SAM Twin Phantom Figure 8-2). Line B-M is perpendicular to the N-F line. Both N-F and B-M lines are marked on the external phantom shell to facilitate handset positioning [5].

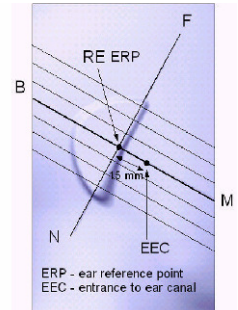

**Figure 8-1**  
Close-Up Side view  
of ERP

### 8.2 HANDSET REFERENCE POINTS

Two imaginary lines on the handset were established: the vertical centerline and the horizontal line. The test device was placed in a normal operating position with the “test device reference point” located along the “vertical centerline” on the front of the device aligned to the “ear reference point” (See Figure 8-3). The “test device reference point” was then located at the same level as the center of the ear reference point. The test device was positioned so that the “vertical centerline” was bisecting the front surface of the handset at its top and bottom edges, positioning the “ear reference point” on the outer surface of the both the left and right head phantoms on the ear reference point.

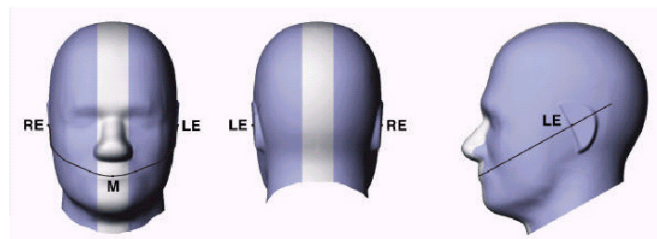

**Figure 8-2**  
Front, back and side view of SAM Twin Phantom

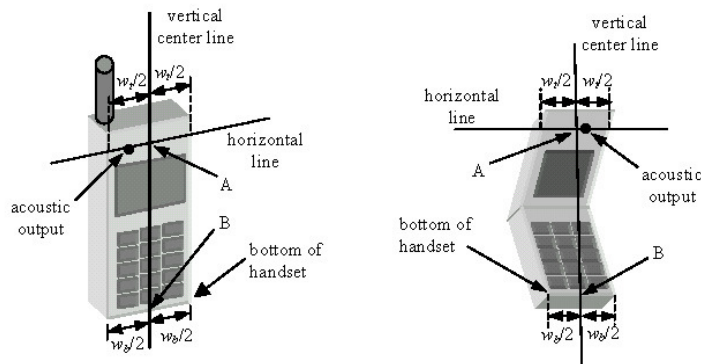

**Figure 8-3**  
Handset Vertical Center & Horizontal Line Reference Points

FCC ID: A3LSGHT839				SAR COMPLIANCE REPORT		Reviewed by: Quality Manager	
Filename: 0Y1102250383.A3L	Test Dates: 02/28/11 - 03/09/11	EUT Type: 850/1900 GSM/GPRS/EDGE and 1700 WCDMA/HSPA Phone with Bluetooth and WLAN				Page 11 of 45	

# 9

# TEST CONFIGURATION POSITIONS

## 9.1 Device Holder

The DASY device holder has been made out of low-loss POM material having the following dielectric parameters: relative permittivity  $\epsilon = 3$  and loss tangent  $\delta = 0.02$ .

## 9.2 Positioning for Cheek/Touch

1. The test device was positioned with the handset close to the surface of the phantom such that point A is on the (virtual) extension of the line passing through points RE and LE on the phantom (see Figure 9-1), such that the plane defined by the vertical center line and the horizontal line of the phone is approximately parallel to the sagittal plane of the phantom.

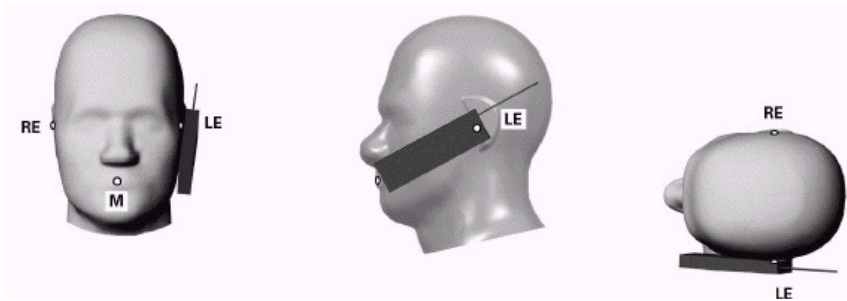



Figure 9-1 Front, Side and Top View of Cheek/Touch Position

2. The handset was translated towards the phantom along the line passing through RE & LE until the handset touches the ear.
3. While maintaining the handset in this plane, the handset was rotated around the LE-RE line until the vertical centerline was in the plane normal to MB-NF including the line MB (reference plane).
4. The phone was then rotated around the vertical centerline until the phone (horizontal line) was symmetrical with respect to the line NF.
5. While maintaining the vertical centerline in the reference plane, keeping point A on the line passing through RE and LE, and maintaining the phone contact with the ear, the handset was rotated about the line NF until any point on the handset made contact with a phantom point below the ear (cheek) (See Figure 9-2).

## 9.3 Positioning for Ear / 15° Tilt

With the test device aligned in the “Cheek/Touch Position”:

1. While maintaining the orientation of the phone, the phone was retracted parallel to the reference plane far enough to enable a rotation of the phone by 15 degree.
2. The phone was then rotated around the horizontal line by 15 degree.
3. While maintaining the orientation of the phone, the phone was moved parallel to the reference plane until any part of the phone touches the head. (In this position, point A was located on the line RE-LE). The tilted position is obtained when the contact is on the pinna. If the contact was at any location other than the pinna, the angle of the phone would then be reduced. The tilted position was obtained when any part of the phone was in contact of the ear as well as a second part of the phone was in contact with the head (see Figure 9-2).

FCC ID: A3LSGHT839		 PCTEST ENGINEERING LABORATORY, INC.		SAR COMPLIANCE REPORT		Reviewed by: Quality Manager	
Filename:	Test Dates:	EUT Type:		Page 12 of 45			
0Y1102250383.A3L	02/28/11 - 03/09/11	850/1900 GSM/GPRS/EDGE and 1700 WCDMA/HSPA Phone with Bluetooth and WLAN					
© 2011 PCTEST Engineering Laboratory, Inc.						REV 8.8M 01/04/2011	

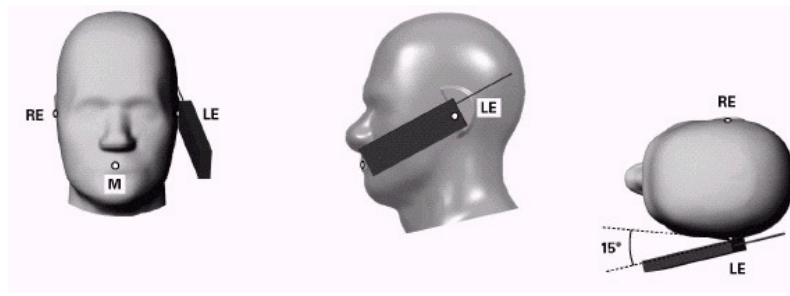

**Figure 9-2 Front, Side and Top View of Ear/15° Tilt Position**

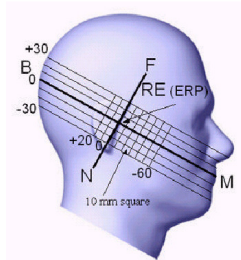

**Figure 9-3 Side view w/ relevant markings**



**Figure 9-4 Body SAR Sample Photo (Not Actual EUT)**

### 9.4 SAR Evaluations near the Mouth/Jaw Regions of the SAM Phantom

Antennas located near the bottom of a phone may require SAR measurements around the mouth and jaw regions of the SAM head phantom. This typically applies to clam-shell style phones that are generally longer in the unfolded normal use positions or to certain older style long rectangular phones. It has been known for some time that there are SAR measurement difficulties in these regions of the SAM phantom. SAR probes are calibrated in tissue equivalent liquids with sufficient separation between the probe sensors and nearby physical boundaries to ensure scattering does not affect probe calibration. When the probe tip is moved into tight regions with multiple boundaries surrounding its sensors, probe calibration and measurement accuracy can become questionable. In addition, these measurement locations often require a probe to be tilted at steep angles, where it may no longer comply with calibration requirements and measurement protocols, or satisfy the required measurement uncertainty. In some situations it is not feasible to tilt the probe or rotate the phantom, as suggested by measurement standards, to conduct these measurements.

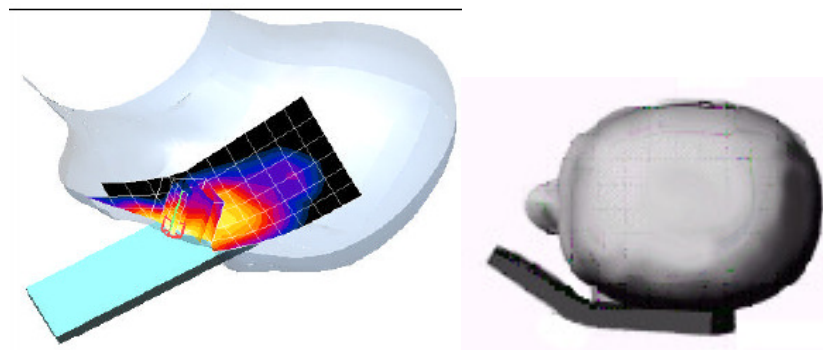

**Figure 9-5 SAR Scans near the Jaw/Mouth**

In order to ensure there is sufficient conservativeness for ensuring compliance until practical solutions are available, additional measurement considerations are necessary to address these technical difficulties. When measurements are required near the mouth, nose, jaw or similar tight regions of the SAM phantom,

FCC ID: A3LSGHT839				SAR COMPLIANCE REPORT		Reviewed by: Quality Manager	
Filename: 0Y1102250383.A3L	Test Dates: 02/28/11 - 03/09/11	EUT Type: 850/1900 GSM/GPRS/EDGE and 1700 WCDMA/HSPA Phone with Bluetooth and WLAN				Page 13 of 45	

area or zoom scans are often unable to fully enclose the peak SAR location as required by IEEE 1528 and Supplement C, due to probe orientation and positioning difficulties. Even when limited measurements are possible, the test results could be questionable due to probe calibration and measurement uncertainty issues. Under these circumstances, the following procedures apply, adopted from the FCC guidance on SAR handsets document publication 648474. The SAR required in these regions of SAM should be measured using a flat phantom. **Rectangular shaped phones** should be positioned with its bottom edge positioned from the flat phantom with the same distance provided by the cheek touching position using SAM. The ear reference point (ERP, as defined for SAM) of the phone should be positioned ½ cm from the flat phantom shell. **Clam-shell phones** should be positioned with the hinge against a smooth edge of the flat phantom where the upper half of the phone is unfolded and extended beyond the phantom side wall. The lower half of the phone is secured in the test device holder at a fixed distance below the flat phantom determined by the minimum separation along the lower edge of the phone in the cheek touching position using SAM. Any case with substantial variation in separation distance along the lower edge of a clam shell is discussed with the FCC for best-to-use methodology.

The flat phantom data should allow test results to be compared uniformly across measurement systems, until suitable solutions are available in measurement standards to address certain probe calibration and positioning issues, due to implementation differences between horizontal and upright SAM configurations. These flat phantom procedures are only applicable for stand-alone SAR evaluation in tight regions of the SAM phantom, where measurement is not feasible or test results can be questionable due to probe calibration and accessibility issues. Details on device positioning and photos showing how separation distances are determined are included in the SAR report Photographs. SAR for other regions of the head must be evaluated using SAM; therefore, a phone with antennas at different locations may require flat and SAM phantom evaluation for the different antennas.

## 9.5 Body Holster /Belt Clip Configurations

Body-worn operating configurations are tested with the belt-clips and holsters attached to the device and positioned against a flat phantom in a normal use configuration (see Figure 9-4). A device with a headset output is tested with a headset connected to the device.

Accessories for Body-worn operation configurations are divided into two categories: those that do not contain metallic components and those that do contain metallic components. When multiple accessories that do not contain metallic components are supplied with the device, the device is tested with only the accessory that dictates the closest spacing to the body. Then multiple accessories that contain metallic components are tested with the device with each accessory. If multiple accessories share an identical metallic component (i.e. the same metallic belt-clip used with different holsters with no other metallic components) only the accessory that dictates the closest spacing to the body is tested.

Body-worn accessories may not always be supplied or available as options for some devices intended to be authorized for body-worn use. In this case, a test configuration with a separation distance between the back of the device and the flat phantom is used. Test position spacing was documented. Transmitters that are designed to operate in front of a person's face, as in push-to-talk configurations, are tested for SAR compliance with the front of the device positioned to face the flat phantom in head fluid. For devices that are carried next to the body such as a shoulder, waist or chest-worn transmitters, SAR compliance is tested with the accessories, including headsets and microphones, attached to the device and positioned against a flat phantom in a normal use configuration.

FCC ID: A3LSGHT839				SAR COMPLIANCE REPORT		Reviewed by: Quality Manager	
Filename:	Test Dates:	EUT Type:		850/1900 GSM/GPRS/EDGE and 1700 WCDMA/HSPA Phone with Bluetooth and WLAN		Page 14 of 45	
0Y1102250383.A3L		02/28/11 - 03/09/11					

# 10 FCC RF EXPOSURE LIMITS

## 10.1 Uncontrolled Environment

UNCONTROLLED ENVIRONMENTS are defined as locations where there is the exposure of individuals who have no knowledge or control of their exposure. The general population/uncontrolled exposure limits are applicable to situations in which the general public may be exposed or in which persons who are exposed as a consequence of their employment may not be made fully aware of the potential for exposure or cannot exercise control over their exposure. Members of the general public would come under this category when exposure is not employment-related; for example, in the case of a wireless transmitter that exposes persons in its vicinity.

## 10.2 Controlled Environment

CONTROLLED ENVIRONMENTS are defined as locations where there is exposure that may be incurred by persons who are aware of the potential for exposure, (i.e. as a result of employment or occupation). In general, occupational/controlled exposure limits are applicable to situations in which persons are exposed as a consequence of their employment, who have been made fully aware of the potential for exposure and can exercise control over their exposure. This exposure category is also applicable when the exposure is of a transient nature due to incidental passage through a location where the exposure levels may be higher than the general population/uncontrolled limits, but the exposed person is fully aware of the potential for exposure and can exercise control over his or her exposure by leaving the area or by some other appropriate means.

**Table 10-1**  
**SAR Human Exposure Specified in ANSI/IEEE C95.1-1992 and Health Canada Safety Code 6**

HUMAN EXPOSURE LIMITS		
	UNCONTROLLED ENVIRONMENT <i>General Population</i> (W/kg) or (mW/g)	CONTROLLED ENVIRONMENT <i>Occupational</i> (W/kg) or (mW/g)
SPATIAL PEAK SAR Brain	1.6	8.0
SPATIAL AVERAGE SAR Whole Body	0.08	0.4
SPATIAL PEAK SAR Hands, Feet, Ankles, Wrists	4.0	20

1. The Spatial Peak value of the SAR averaged over any 1 gram of tissue (defined as a tissue volume in the shape of a cube) and over the appropriate averaging time.
2. The Spatial Average value of the SAR averaged over the whole body.
3. The Spatial Peak value of the SAR averaged over any 10 grams of tissue (defined as a tissue volume in the shape of a cube) and over the appropriate averaging time.

FCC ID: A3LSGHT839				SAR COMPLIANCE REPORT		Reviewed by: Quality Manager		
Filename: 0Y1102250383.A3L	Test Dates: 02/28/11 - 03/09/11	EUT Type: 850/1900 GSM/GPRS/EDGE and 1700 WCDMA/HSPA Phone with Bluetooth and WLAN						Page 15 of 45

# 11 FCC 3G MEASUREMENT PROCEDURES

Power measurements were performed using a base station simulator under digital average power.

## 11.1 Procedures Used to Establish RF Signal for SAR

The device was placed into a simulated call using a base station simulator in a shielded chamber. Such test signals offer a consistent means for testing SAR and are recommended for evaluating SAR [4]. SAR measurements were taken with a fully charged battery. In order to verify that the device was tested and maintained at full power, it was configured with the base station simulator. The SAR measurement software calculates a reference point at the start and end of the test to check for power drifts. If SAR deviations of more than 5% occurred, the tests were repeated.

## 11.2 SAR Measurement Conditions for UMTS

### 11.2.1 Output Power Verification

Maximum output power is verified on the High, Middle and Low channels according to the general descriptions in section 5.2 of 3GPP TS 34.121, using the appropriate RMC or AMR with TPC (transmit power control) set to all "1s".

### 11.2.2 Head SAR Measurements

SAR for head exposure configurations is measured using the 12.2 kbps RMC with TPC bits configured to all "1s". SAR in AMR configurations is not required when the maximum average output of each RF channel for 12.2 kbps AMR is less than ¼ dB higher than that measured in 12.2 kbps RMC. Otherwise, SAR is measured on the maximum output channel in 12.2 AMR with a 3.4 kbps SRB (signaling radio bearer) using the exposure configuration that results in the highest SAR for that RF channel in 12.2 RMC.

### 11.2.3 Body SAR Measurements

SAR for body exposure configurations is measured using the 12.2 kbps RMC with the TPC bits all "1s".

### 11.2.4 Handsets with HSDPA

Body SAR is not required for handsets with HSDPA capabilities when the maximum average output of each RF channel with HSDPA active is less than ¼ dB higher than that measured without HSDPA using 12.2 kbps RMC and the maximum SAR for 12.2 kbps RMC is  $\leq 75\%$  of the SAR limit. Otherwise, SAR is measured for HSDPA, using an FRC with H-Set 1 in Sub-test 1 and a 12.2 kbps RMC configured in Test Loop Mode 1, using the highest body SAR configuration in 12.2 kbps RMC without HSDPA, on the maximum output channel with the body exposure configuration that results in the highest SAR in 12.2 kbps RMC for that RF channel.

FCC ID: A3LSGHT839				SAR COMPLIANCE REPORT		Reviewed by: Quality Manager	
Filename:	Test Dates:	EUT Type:		850/1900 GSM/GPRS/EDGE and 1700 WCDMA/HSPA Phone with Bluetooth and WLAN		Page 16 of 45	
0Y1102250383.A3L	02/28/11 - 03/09/11						

## 11.3 RF Conducted Powers

### 11.3.1 GSM Conducted Burst Powers

		RF Conducted Power Table				
		Voice	GPRS Data		EDGE Data	
Band	Channel	GSM [dBm] CS (1 Slot)	GPRS [dBm] 1 Tx Slot	GPRS [dBm] 2 Tx Slot	EDGE [dBm] 1 Tx Slot	EDGE [dBm] 2 Tx Slot
Cellular	128	32.16	32.18	32.16	26.65	26.66
	190	32,34	32.27	32.24	26.76	26.79
	251	32.23	32.28	32.24	26.66	26.68
PCS	512	29.43	29.43	29.41	25.14	25.11
	661	29.34	29.35	29.34	24.95	24.95
	810	29.17	29.17	29.14	24.88	24.92

**GSM Class: B**

**GPRS Multislot class: 10** (max 2 Tx Uplink slots)

**EDGE Multislot class: 10** (max 2Tx Uplink slots)

**DTM Multislot Class: N/A**

### 11.3.2 HSPA Conducted Powers

3GPP Release Version	Mode	3GPP 34.121 Subtest	AWS Band [dBm]			$\beta_c$	$\beta_d$	$\Delta E$ -DPCCH	# of E-TFCI's	MPR
			1312	1412	1862					
99	WCDMA	12.2 kbps RMC	23.03	22.99	22.85	-	-	-	-	-
99		12.2 kbps AMR	23.02	22.92	22.83	-	-	-	-	-
6	HSDPA	Subtest 1	22.18	22.17	21.97	2	15			0
6		Subtest 2	22.23	22.18	21.99	11	15			0
6		Subtest 3	21.72	21.73	21.53	15	8	5	1	0.5
6		Subtest 4	21.72	21.69	21.49	15	4	5	1	0.5
6	HSUPA	Subtest 1	22.25	22.19	21.97	10	15	6	5	0
6		Subtest 2	20.39	20.36	20.19	6	15	8	5	2
6		Subtest 3	21.25	21.20	21.01	15	9	8	2	1
6		Subtest 4	20.29	20.24	20.17	2	15	5	5	2
6		Subtest 5	22.24	22.24	22.05	14	15	7	5	0

Note: The applicant has confirmed that an additional 1 dB of MPR is applied for all subtests. Detailed information is included in the operational description explaining the MPR applied for this model.

FCC ID: A3LSGHT839		SAR COMPLIANCE REPORT	Reviewed by: Quality Manager
--------------------	---	-----------------------	---------------------------------

Filename: 0Y1102250383.A3L	Test Dates: 02/28/11 - 03/09/11	EUT Type: 850/1900 GSM/GPRS/EDGE and 1700 WCDMA/HSPA Phone with Bluetooth and WLAN	Page 17 of 45
-------------------------------	------------------------------------	---	---------------

### 11.3.1 Bluetooth Conducted Powers

Frequency [MHz]	Data Rate [Mbps]	Channel No.	Peak Conducted Power	
			[dBm]	[mW]
2402	1.0	0	8.52	7.112
2441	1.0	39	9.13	8.185
2480	1.0	78	9.12	8.166
2402	2.0	0	11.73	14.894
2441	2.0	39	12.52	17.865
2480	2.0	78	12.34	17.140
2402	3.0	0	9.21	8.337
2441	3.0	39	10.14	10.328
2480	3.0	78	10.26	10.617



**Figure 11-1**  
**Power Measurement Setup**

# 12 SAR TESTING WITH IEEE 802.11 TRANSMITTERS

Normal network operating configurations are not suitable for measuring the SAR of 802.11 a/b/g transmitters. Unpredictable fluctuations in network traffic and antenna diversity conditions can introduce undesirable variations in SAR results. The SAR for these devices should be measured using chipset based test mode software to ensure the results are consistent and reliable.

## 12.1 General Device Setup

Chipset based test mode software is hardware dependent and generally varies among manufacturers. The device operating parameters established in test mode for SAR measurements must be identical to those programmed in production units, including output power levels, amplifier gain settings and other RF performance tuning parameters. The test frequencies should correspond to actual channel frequencies defined for domestic use. SAR for devices with switched diversity should be measured with only one antenna transmitting at a time during each SAR measurement, according to a fixed modulation and data rate. The same data pattern should be used for all measurements.

## 12.2 Frequency Channel Configurations [27]

802.11 a/b/g and 4.9 GHz operating modes are tested independently according to the service requirements in each frequency band. 802.11 b/g modes are tested on channels 1, 6 and 11. 802.11a is tested for UNII operations on channels 36 and 48 in the 5.15-5.25 GHz band; channels 52 and 64 in the 5.25-5.35 GHz band; channels 104, 116, 124 and 136 in the 5.470-5.725 GHz band; and channels 149 and 161 in the 5.8 GHz band. When 5.8 GHz §15.247 is also available, channels 149, 157 and 165 should be tested instead of the UNII channels. 4.9 GHz is tested on channels 1, 10 and 5 or 6, whichever has the higher output power, for 5 MHz channels; channels 11, 15 and 19 for 10 MHz channels; and channels 21 and 25 for 20 MHz channels. These are referred to as the “default test channels”. 802.11g mode was evaluated only if the output power was 0.25 dB higher than the 802.11b mode.

**Table 12-1  
802.11 Test Channels per FCC Requirements**

Mode	GHz	Channel	Turbo Channel	“Default Test Channels”		
				§15.247 802.11b	802.11g	UNII
802.11 b/g	2.412	1		√	∇	
	2.437	6	6	√	∇	
	2.462	11		√	∇	
802.11a	5.18	36				√
	5.20	40	42 (5.21 GHz)			*
	5.22	44				*
	5.24	48	50 (5.25 GHz)			√
	5.26	52				√
	5.28	56	58 (5.29 GHz)			*
	5.30	60				*
	5.32	64				√
	5.500	100	Unknown			*
	5.520	104				√
	5.540	108				*
	5.560	112				*
	5.580	116				√
	5.600	120				*
	5.620	124				√
	5.640	128				*
	5.660	132				*
	5.680	136				√
	5.700	140			*	
	UNII or §15.247	5.745	149		√	
5.765		153	152 (5.76 GHz)		*	*
5.785		157		√		*
5.805		161	160 (5.80 GHz)		*	√
§15.247	5.825	165		√		

FCC ID: A3LSGHT839		SAR COMPLIANCE REPORT	Reviewed by: Quality Manager
--------------------	---	-----------------------	---------------------------------

Filename: 0Y1102250383.A3L	Test Dates: 02/28/11 - 03/09/11	EUT Type: 850/1900 GSM/GPRS/EDGE and 1700 WCDMA/HSPA Phone with Bluetooth and WLAN	Page 19 of 45
-------------------------------	------------------------------------	---	---------------

**Table 12-2**  
**IEEE 802.11b Average RF Power**

Freq [MHz]	Channel	Data Rate [Mbps]	Average Power (dBm)
2412	1	1	17.54
		2	17.26
		5.5	17.45
		11	17.13
2437	6	1	17.57
		2	17.61
		5.5	17.34
		11	17.35
2462	11	1	17.64
		2	17.46
		5.5	17.61
		11	17.24

**Table 12-3**  
**IEEE 802.11g Average RF Power**

Freq [MHz]	Channel	Data Rate [Mbps]	Average Power (dBm)
2412	1	6	14.09
		9	14.22
		12	14.03
		18	14.01
		24	14.13
		36	13.86
		48	14.01
		54	14.02
		2437	6
9	14.1		
12	14.14		
18	14.29		
24	14.01		
36	14.48		
48	14.35		
54	14.37		
2462	11		
		9	14.03
		12	13.97
		18	13.95
		24	14.01
		36	13.85
		48	14.01
		54	14.47

**Table 12-4  
IEEE 802.11n Average RF Power**

Freq [MHz]	Channel	Data Rate [Mbps]	Average Power (dBm)
2412	1	6.5/7.2	11.79
		13/14.40	11.04
		19.5/21.70	11.14
		26/28.90	11.06
		29/43.3	11.15
		52/57.80	11.03
		58.50/65	11.04
		65/72.2	10.99
2437	6	6.5/7.2	11.59
		13/14.40	11.3
		19.5/21.70	11.33
		26/28.90	11.25
		29/43.3	11.18
		52/57.80	11.29
		58.50/65	11.6
		65/72.2	11.09
2462	11	6.5/7.2	11.93
		13/14.40	11.4
		19.5/21.70	11.37
		26/28.90	11.28
		29/43.3	11.22
		52/57.80	11.27
		58.50/65	11.25
		65/72.2	11.03



**Figure 12-1  
Power Measurement Setup**

# 13 SINGLE TX SAR CONSIDERATIONS

## 13.1 SAR Test Configurations

**Table 13-1**  
**Mobile Hotspot Sides for SAR Testing**

Mobile Hotspot Side for SAR Testing						
Mode	Back	Front	Right	Left	Top	Bottom
850 GPRS	Yes	Yes	Yes	Yes	No	Yes
1900 GPRS	Yes	Yes	Yes	Yes	No	Yes
UMTS IV	Yes	Yes	Yes	Yes	No	Yes
2.4 GHz WIFI	Yes	Yes	Yes	No	No	Yes

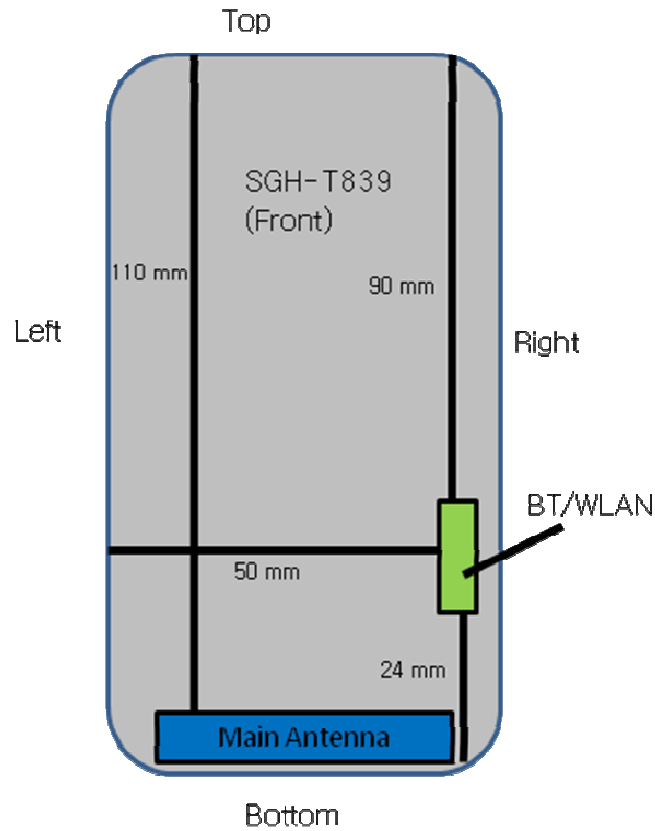

**Figure 13-1**  
**Identification of Sides for SAR Testing**

Note: Per Oct 2010 TCB FCC Workshop, the edges with antennas within 2.5 cm are required to be evaluated for SAR. See Figure 13-1 for distances of the actual device.

# 14 SYSTEM VERIFICATION

## 14.1 Tissue Verification

**Table 14-1  
Measured Tissue Properties**

Calibrated for Tests Performed on:	Tissue Type	Measured Frequency (MHz)	Measured Conductivity, $\sigma$ (S/m)	Measured Dielectric Constant, $\epsilon$	TARGET Conductivity, $\sigma$ (S/m)	TARGET Dielectric Constant, $\epsilon$	% dev $\sigma$	% dev $\epsilon$
02/28/2011	835H	820	0.868	42.98	0.898	41.571	-3.34%	3.39%
		835	0.885	42.66	0.900	41.500	-1.67%	2.80%
		850	0.900	42.49	0.916	41.500	-1.75%	2.39%
02/28/2011	835B	820	0.946	53.21	0.969	55.284	-2.37%	-3.75%
		835	0.959	52.89	0.970	55.200	-1.13%	-4.18%
		850	0.970	52.92	0.988	55.154	-1.82%	-4.05%
03/04/2011	1750H	1710	1.350	40.78	1.348	40.136	0.15%	1.60%
		1750	1.388	40.55	1.370	40.100	1.31%	1.12%
		1790	1.425	40.45	1.394	40.020	2.22%	1.07%
03/04/2011	1750B	1710	1.515	53.61	1.460	53.540	3.77%	0.13%
		1750	1.556	53.58	1.490	53.430	4.43%	0.28%
		1790	1.578	53.47	1.510	53.330	4.50%	0.26%
03/02/2011	1900H	1850	1.413	40.42	1.400	40.000	0.93%	1.05%
		1880	1.453	40.30	1.400	40.000	3.79%	0.75%
		1910	1.467	40.20	1.400	40.000	4.79%	0.50%
02/28/2011	1900B	1850	1.554	51.18	1.520	53.300	2.24%	-3.98%
		1880	1.588	51.15	1.520	53.300	4.47%	-4.03%
		1910	1.594	51.02	1.520	53.300	4.87%	-4.28%
03/03/2011	2450H	2401	1.785	38.29	1.758	39.298	1.54%	-2.57%
		2450	1.825	38.08	1.800	39.200	1.39%	-2.86%
		2499	1.896	37.91	1.852	39.135	2.38%	-3.13%
03/01/2011	2450B	2401	1.814	51.23	1.903	52.765	-4.68%	-2.91%
		2450	1.879	51.11	1.950	52.700	-3.64%	-3.02%
		2499	1.946	50.99	2.019	52.638	-3.62%	-3.13%
03/09/2011	2450B	2401	1.970	50.88	1.903	52.765	3.52%	-3.57%
		2450	2.033	50.78	1.950	52.700	4.26%	-3.64%
		2499	2.113	50.57	2.019	52.638	4.66%	-3.93%

Note: KDB Publication 450824 was ensured to be applied for probe calibration frequencies greater than or equal to 50 MHz of the DUT frequencies.

The above measured tissue parameters were used in the DASY software to perform interpolation via the DASY software to determine actual dielectric parameters at the test frequencies (per IEEE 1528 6.6.1.2). The SAR test plots may slightly differ from the table above since the DASY software rounds to three significant digits.

## 14.2 Measurement Procedure for Tissue verification

- 1) The network analyzer and probe system was configured and calibrated.
- 2) The probe was immersed in the sample which was placed in a nonmetallic container. Trapped air bubbles beneath the flange were minimized by placing the probe at a slight angle.
- 3) The complex admittance with respect to the probe aperture was measured
- 4) The complex relative permittivity, for example from the below equation (Pournaropoulos and Misra):

FCC ID: A3LSGHT839		SAR COMPLIANCE REPORT	Reviewed by: Quality Manager
--------------------	---	-----------------------	---------------------------------

Filename: 0Y1102250383.A3L	Test Dates: 02/28/11 - 03/09/11	EUT Type: 850/1900 GSM/GPRS/EDGE and 1700 WCDMA/HSPA Phone with Bluetooth and WLAN	Page 23 of 45
-------------------------------	------------------------------------	---	---------------

$$Y = \frac{j2\omega\epsilon_r\epsilon_0}{[\ln(b/a)]^2} \int_a^b \int_a^b \int_0^\pi \cos\phi' \frac{\exp[-j\omega r(\mu_0\epsilon_r\epsilon_0)^{1/2}]}{r} d\phi' d\rho' d\rho$$

where Y is the admittance of the probe in contact with the sample, the primed and unprimed coordinates refer to source and observation points, respectively,  $r^2 = \rho^2 + \rho'^2 - 2\rho\rho' \cos\phi'$ ,  $\omega$  is the angular frequency, and  $j = \sqrt{-1}$ .

### 14.3 Justification for Extended SAR Dipole Calibrations

Usage of SAR dipoles calibrated less than 2 years ago but more than 1 year ago were confirmed in maintaining return loss (< -20 dB, within 20% of prior calibration) and impedance (within 5 ohm from prior calibration) requirements per extended calibrations in KDB Publication 450824:

D835V2 SN: 4d026								
	Head				Body			
Date of Measurement	Return Loss (dB)	$\Delta$ %	Impedance ( $\Omega$ )	$\Delta\Omega$	Return Loss (dB)	$\Delta$ %	Impedance ( $\Omega$ )	$\Delta\Omega$
8/24/2009	-22.5		51		-20.6		46.9	
3/2/2011	-22.7	0.9%	50.1	-0.9	-20.9	1.5%	48	1.1

D1765V2 SN: 1008								
	Head				Body			
Date of Measurement	Return Loss (dB)	$\Delta$ %	Impedance ( $\Omega$ )	$\Delta\Omega$	Return Loss (dB)	$\Delta$ %	Impedance ( $\Omega$ )	$\Delta\Omega$
5/19/2009	-29.9		48.4		-24.2		44.8	
3/2/2011	-30.1	0.7%	49	0.6	-24.0	-1%	47	2.2

D2450V2 SN: 719								
	Head				Body			
Date of Measurement	Return Loss (dB)	$\Delta$ %	Impedance ( $\Omega$ )	$\Delta\Omega$	Return Loss (dB)	$\Delta$ %	Impedance ( $\Omega$ )	$\Delta\Omega$
8/27/2009	-28.6		53.4		-27.2		48.2	0.0
3/2/2011	-28.6	0.0%	52	-1.4	-27.4	0.7%	49.9	1.7

## 14.4 Test System Verification

Prior to assessment, the system is verified to  $\pm 10\%$  of the manufacturer SAR measurement on the reference dipole at the time of calibration.

**Table 14-2**  
**System Verification Results**

System Verification TARGET & MEASURED										
Date:	Amb. Temp (°C)	Liquid Temp (°C)	Input Power (W)	Tissue Frequency (MHz)	Dipole SN	Tissue Type	Measured SAR <sub>1g</sub> (W/kg)	1 W Target SAR <sub>1g</sub> (W/kg)	1 W Normalized SAR <sub>1g</sub> (W/kg)	Deviation (%)
02/28/2011	23.8	21.9	0.063	835	4d026	Head	0.58	9.460	9.21	-2.68%
02/28/2011	23.7	22.0	0.063	835	4d026	Body	0.616	9.780	9.78	-0.02%
03/04/2011	22.4	21.2	0.040	1765	1008	Head	1.47	38.200	36.75	-3.80%
03/04/2011	23.3	21.4	0.040	1765	1008	Body	1.47	37.300	36.75	-1.47%
03/02/2011	24.2	22.5	0.040	1900	502	Head	1.59	40.200	39.75	-1.12%
02/28/2011	24.6	22.8	0.100	1900	502	Body	4.3	41.100	43.00	4.62%
03/02/2011	23.8	21.9	0.025	2450	719	Head	1.27	53.500	50.80	-5.05%
03/01/2011	24.8	23.5	0.025	2450	719	Body	1.35	51.400	54.00	5.06%
03/09/2011	23.8	22.4	0.016	2450	797	Head	0.841	52.300	53.23	1.77%

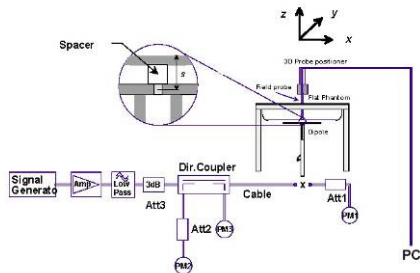

**Figure 14-1**  
**System Verification Setup Diagram**



**Figure 14-2**  
**System Verification Setup Photo**

FCC ID: A3LSGHT839		SAR COMPLIANCE REPORT	Reviewed by: Quality Manager
--------------------	---	-----------------------	---------------------------------

Filename: 0Y1102250383.A3L	Test Dates: 02/28/11 - 03/09/11	EUT Type: 850/1900 GSM/GPRS/EDGE and 1700 WCDMA/HSPA Phone with Bluetooth and WLAN	Page 25 of 45
-------------------------------	------------------------------------	---	---------------

# 15 SAR DATA SUMMARY

Table 15-1  
GSM 850 Head SAR Results

MEASUREMENT RESULTS							
FREQUENCY		Mode/Band	C_Power[dBm]		Side	Test Position	SAR (1g)
MHz	Ch.		Start	End			(W/kg)
836.60	190	GSM 850	32.34	32.36	Right	Touch	0.133
836.60	190	GSM 850	32.34	32.33	Right	Tilt	0.099
836.60	190	GSM 850	32.34	32.32	Left	Touch	0.137
836.60	190	GSM 850	32.34	32.37	Left	Tilt	0.088
<b>ANSI / IEEE C95.1 1992 - SAFETY LIMIT</b>					<b>Brain</b>		
<b>Spatial Peak</b>					<b>1.6 W/kg (mW/g)</b>		
<b>Uncontrolled Exposure/General</b>					<b>averaged over 1 gram</b>		

Notes:

1. The test data reported are the worst-case SAR value with the position set in a typical configuration. Test procedures used were according to FCC/OET Bulletin 65, Supplement C [June 2001].
2. All modes of operation were investigated, and worst-case results are reported.
3. Batteries are fully charged for all readings. Standard battery was used.
4. Tissue parameters and temperatures are listed on the SAR plots.
5. Liquid tissue depth was at least 15.0 cm.
6. Justification for reduced test configurations: Per FCC/OET Bulletin 65 Supplement C (June 2001) and Public Notice DA-02-1438, if the SAR measured at the middle channel for each test configuration (left, right, cheek/touch, tilt/ear, extended and retracted) is at least 3.0 dB lower than the SAR limit, testing at the high and low channels is optional for such test configuration(s).

FCC ID: A3LSGHT839				SAR COMPLIANCE REPORT		Reviewed by: Quality Manager	
Filename:	Test Dates:	EUT Type:					
0Y1102250383.A3L	02/28/11 - 03/09/11	850/1900 GSM/GPRS/EDGE and 1700 WCDMA/HSPA Phone with Bluetooth and WLAN					
						Page 26 of 45	

**Table 15-2  
GSM 1900 Head SAR Results**

<b>MEASUREMENT RESULTS</b>							
<b>FREQUENCY</b>		<b>Mode/Band</b>	<b>C_Power[dBm]</b>		<b>Side</b>	<b>Test Position</b>	<b>SAR (1g)</b>
<b>MHz</b>	<b>Ch.</b>		<b>Start</b>	<b>End</b>			<b>(W/kg)</b>
1880.00	661	GSM 1900	29.34	29.32	Right	Touch	<b>0.148</b>
1880.00	661	GSM 1900	29.34	29.32	Right	Tilt	<b>0.128</b>
1880.00	661	GSM 1900	29.34	29.37	Left	Touch	<b>0.176</b>
1880.00	661	GSM 1900	29.34	29.41	Left	Tilt	<b>0.114</b>
<b>ANSI / IEEE C95.1 1992 - SAFETY LIMIT</b>					<b>Brain</b>		
<b>Spatial Peak</b>					<b>1.6 W/kg (mW/g)</b>		
<b>Uncontrolled Exposure/General</b>					averaged over 1 gram		

Notes:

1. The test data reported are the worst-case SAR value with the position set in a typical configuration. Test procedures used were according to FCC/OET Bulletin 65, Supplement C [June 2001].
2. All modes of operation were investigated, and worst-case results are reported.
3. Batteries are fully charged for all readings. Standard battery was used.
4. Tissue parameters and temperatures are listed on the SAR plots.
5. Liquid tissue depth was at least 15.0 cm.
6. Justification for reduced test configurations: Per FCC/OET Bulletin 65 Supplement C (June 2001) and Public Notice DA-02-1438, if the SAR measured at the middle channel for each test configuration (left, right, cheek/touch, tilt/ear, extended and retracted) is at least 3.0 dB lower than the SAR limit, testing at the high and low channels is optional for such test configuration(s).

**Table 15-3  
UMTS IV Head SAR Results**

<b>MEASUREMENT RESULTS</b>							
<b>FREQUENCY</b>		<b>Mode/Band</b>	<b>C_Power[dBm]</b>		<b>Side</b>	<b>Test Position</b>	<b>SAR (1g)</b>
<b>MHz</b>	<b>Ch.</b>		<b>Start</b>	<b>End</b>			<b>(W/kg)</b>
1730.40	1412	UMTS IV	22.99	22.99	Right	Touch	<b>0.254</b>
1730.40	1412	UMTS IV	22.99	22.98	Right	Tilt	<b>0.256</b>
1730.40	1412	UMTS IV	22.99	22.90	Left	Touch	<b>0.335</b>
1730.40	1412	UMTS IV	22.99	22.99	Left	Tilt	<b>0.232</b>
<b>ANSI / IEEE C95.1 1992 - SAFETY LIMIT</b>					<b>Brain</b>		
<b>Spatial Peak</b>					<b>1.6 W/kg (mW/g)</b>		
<b>Uncontrolled Exposure/General Population</b>					averaged over 1 gram		

Notes:

1. The test data reported are the worst-case SAR value with the position set in a typical configuration. Test procedures used were according to FCC/OET Bulletin 65, Supplement C [June 2001].
2. All modes of operation were investigated, and worst-case results are reported.
3. Batteries are fully charged for all readings. Standard battery was used.
4. Tissue parameters and temperatures are listed on the SAR plots.
5. Liquid tissue depth was at least 15.0 cm.
6. Justification for reduced test configurations: Per FCC/OET Bulletin 65 Supplement C (June 2001) and Public Notice DA-02-1438, if the SAR measured at the middle channel for each test configuration (left, right, cheek/touch, tilt/ear, extended and retracted) is at least 3.0 dB lower than the SAR limit, testing at the high and low channels is optional for such test configuration(s).
7. WCDMA mode was tested under RMC 12.2 kbps with HSPA Inactive.

<b>FCC ID:</b> A3LSGHT839		<b>SAR COMPLIANCE REPORT</b>	<b>Reviewed by:</b> Quality Manager
<b>Filename:</b> 0Y1102250383.A3L	<b>Test Dates:</b> 02/28/11 - 03/09/11	<b>EUT Type:</b> 850/1900 GSM/GPRS/EDGE and 1700 WCDMA/HSPA Phone with Bluetooth and WLAN	Page 28 of 45

**Table 15-4  
2.4 GHz WLAN Head SAR Results**

<b>MEASUREMENT RESULTS</b>									
FREQUENCY		Mode	Service	C_Power[dBm]		Side	Test Position	Data Rate (Mbps)	SAR (1g)
MHz	Ch.			Start	End				(W/kg)
2462	11	IEEE 802.11b	DSSS	17.64	17.62	Right	Touch	1	<b>0.323</b>
2462	11	IEEE 802.11b	DSSS	17.64	17.63	Right	Tilt	1	<b>0.093</b>
2462	11	IEEE 802.11b	DSSS	17.64	17.64	Left	Touch	1	<b>0.210</b>
2462	11	IEEE 802.11b	DSSS	17.64	17.67	Left	Tilt	1	<b>0.172</b>
<b>ANSI / IEEE C95.1 1992 - SAFETY LIMIT Spatial Peak Uncontrolled Exposure/General Population</b>						<b>Brain 1.6 W/kg (mW/g) averaged over 1 gram</b>			

Notes:

1. The test data reported are the worst-case SAR value with the position set in a typical configuration. Test procedures used were according to FCC/OET Bulletin 65, Supplement C [June 2001].
2. All modes of operation were investigated, and worst-case results are reported.
3. Batteries are fully charged for all readings. Standard battery was used.
4. Tissue parameters and temperatures are listed on the SAR plots.
5. Liquid tissue depth was at least 15.0 cm.
6. Justification for reduced test configurations for WIFI channels per KDB Publication 248227 and April 2010 FCC/TCB Meeting Notes: Highest average RF output power channel for the lowest data rate were selected for SAR evaluation. Other IEEE 802.11 modes (including 802.11n) were not investigated since the average output powers were not greater than 0.25 dB than that of the corresponding channel in the lowest data rate IEEE 802.11b mode.
7. WLAN transmission was verified using a spectrum analyzer.

**Table 15-5  
GPRS Body SAR Results (Hotspot)**

MEASUREMENT RESULTS									
FREQUENCY		Mode	Service	C_Power[dBm]		Spacing	Slots	Side	SAR (1g)
MHz	Ch.			Start	End				(W/kg)
824.20	128	GSM 850	GPRS	32.16	32.14	1.0 cm	2	back	0.881
836.60	190	GSM 850	GPRS	32.24	32.21	1.0 cm	2	back	0.963
848.80	251	GSM 850	GPRS	32.24	32.23	1.0 cm	2	back	0.921
836.60	190	GSM 850	GPRS	32.24	32.24	1.0 cm	2	front	0.386
836.60	190	GSM 850	GPRS	32.24	32.20	1.0 cm	2	bottom	0.068
836.60	190	GSM 850	GPRS	32.24	32.23	1.0 cm	2	right	0.455
836.60	190	GSM 850	GPRS	32.24	32.28	1.0 cm	2	left	0.363
1880.00	661	GSM 1900	GPRS	29.34	29.34	1.0 cm	2	back	0.682
1880.00	661	GSM 1900	GPRS	29.34	29.33	1.0 cm	2	front	0.460
1880.00	661	GSM 1900	GPRS	29.34	29.34	1.0 cm	2	bottom	0.341
1880.00	661	GSM 1900	GPRS	29.34	29.35	1.0 cm	2	right	0.202
1880.00	661	GSM 1900	GPRS	29.34	29.34	1.0 cm	2	left	0.215
<b>ANSI / IEEE C95.1 1992 - SAFETY LIMIT</b>						<b>Body</b>			
<b>Spatial Peak</b>						<b>1.6 W/kg (mW/g)</b>			
<b>Uncontrolled Exposure/General Population</b>						averaged over 1 gram			

Notes:

- The test data reported are the worst-case SAR value with the position set in a typical configuration. Test procedures used were according to FCC/OET Bulletin 65, Supplement C [June 2001].
- All modes of operation were investigated, and worst-case results are reported.
- Tissue parameters and temperatures are listed on the SAR plots.
- Batteries are fully charged for all readings. Standard battery was used.
- Liquid tissue depth was at least 15.0 cm.
- Device was tested using a fixed spacing.
- Justification for reduced test configurations per KDB Publication 941225: The source-based time-averaged output power was evaluated for all multi-slot operations. In addition to the worst-case reported, all source-based time-averaged powers within 10% of the worst-case were additionally included in the evaluation.
- Justification for reduced test configurations: Per FCC/OET Bulletin 65 Supplement C (June 2001) and Public Notice DA-02-1438, if the SAR measured at the middle channel for each test configuration is at least 3.0 dB lower than the SAR limit, testing at the high and low channels is optional for such test configuration(s).
- Top Edge was not required since the antenna distance from the edge was greater than 2.5 cm per Oct 2010 TCB Workshop guidance (see Section 13.1).

FCC ID: A3LSGHT839			<b>SAR COMPLIANCE REPORT</b>	<b>Reviewed by:</b> Quality Manager
<b>Filename:</b> 0Y1102250383.A3L	<b>Test Dates:</b> 02/28/11 - 03/09/11	<b>EUT Type:</b> 850/1900 GSM/GPRS/EDGE and 1700 WCDMA/HSPA Phone with Bluetooth and WLAN		Page 30 of 45

**Table 15-6  
WCDMA Body SAR Results (Hotspot)**

<b>MEASUREMENT RESULTS</b>								
<b>FREQUENCY</b>		<b>Mode</b>	<b>Service</b>	<b>C_Power[dBm]</b>		<b>Spacing</b>	<b>Side</b>	<b>SAR (1g)</b>
<b>MHz</b>	<b>Ch.</b>			<b>Start</b>	<b>End</b>			<b>(W/kg)</b>
1712.40	1312	UMTS IV	RMC	23.03	23.00	1.0 cm	back	<b>0.763</b>
1730.40	1412	UMTS IV	RMC	22.99	22.96	1.0 cm	back	<b>0.809</b>
1752.50	1862	UMTS IV	RMC	22.85	22.84	1.0 cm	back	<b>0.738</b>
1730.40	1412	UMTS IV	RMC	22.99	23.01	1.0 cm	front	<b>0.466</b>
1730.40	1412	UMTS IV	RMC	22.99	22.94	1.0 cm	bottom	<b>0.341</b>
1730.40	1412	UMTS IV	RMC	22.99	22.97	1.0 cm	right	<b>0.145</b>
1730.40	1412	UMTS IV	RMC	22.99	22.99	1.0 cm	left	<b>0.197</b>
<b>ANSI / IEEE C95.1 1992 - SAFETY LIMIT</b>						<b>Body</b>		
<b>Spatial Peak</b>						<b>1.6 W/kg (mW/g)</b>		
<b>Uncontrolled Exposure/General Population</b>						<b>averaged over 1 gram</b>		

**Notes:**

1. The test data reported are the worst-case SAR value with the position set in a typical configuration. Test procedures used were according to FCC/OET Bulletin 65, Supplement C [June 2001].
2. All modes of operation were investigated, and worst-case results are reported.
3. Tissue parameters and temperatures are listed on the SAR plots.
4. Batteries are fully charged for all readings. Standard battery was used.
5. Liquid tissue depth was at least 15.0 cm.
6. Device was tested using a fixed spacing.
7. WCDMA mode in Body SAR was tested under RMC 12.2 kbps with HSPA Inactive.
8. Justification for reduced test configurations: Per FCC/OET Bulletin 65 Supplement C (June 2001) and Public Notice DA-02-1438, if the SAR measured at the middle channel for each test configuration is at least 3.0 dB lower than the SAR limit, testing at the high and low channels is optional for such test configuration(s).
9. Top Edge was not required since the antenna distance from the edge was greater than 2.5 cm per Oct 2010 TCB Workshop guidance (see Section 13.1).

<b>FCC ID:</b> A3LSGHT839		<b>SAR COMPLIANCE REPORT</b>	<b>Reviewed by:</b> Quality Manager
<b>Filename:</b> 0Y1102250383.A3L	<b>Test Dates:</b> 02/28/11 - 03/09/11	<b>EUT Type:</b> 850/1900 GSM/GPRS/EDGE and 1700 WCDMA/HSPA Phone with Bluetooth and WLAN	Page 31 of 45

**Table 15-7  
2.4 GHz Body SAR Results**

<b>MEASUREMENT RESULTS</b>									
FREQUENCY		Mode	Service	C_Power[dBm]		Spacing	Data Rate (Mbps)	Side	SAR
MHz	Ch.			Start	End				(W/kg)
2462	11	IEEE 802.11b	DSSS	17.64	17.61	1.0 cm	1	back	0.542
2462	11	IEEE 802.11b	DSSS	17.64	17.62	1.0 cm	1	front	0.048
2462	11	IEEE 802.11b	DSSS	17.64	17.62	1.0 cm	1	bottom	0.019
2441	39	Bluetooth	FHSS	12.52	12.50	1.0 cm	2	back	0.025
<b>ANSI / IEEE C95.1 1992 - SAFETY LIMIT</b>						<b>Body</b>			
<b>Spatial Peak</b>						<b>1.6 W/kg (mW/g)</b>			
<b>Uncontrolled Exposure/General Population</b>						averaged over 1 gram			

Notes:

1. The test data reported are the worst-case SAR value with the position set in a typical configuration. Test procedures used were according to FCC/OET Bulletin 65, Supplement C [June 2001].
2. All modes of operation were investigated, and worst-case results are reported.
3. Batteries are fully charged for all readings. Standard battery was used.
4. Tissue parameters and temperatures are listed on the SAR plots.
5. Liquid tissue depth is was at least 15.0 cm.
6. Device was tested using a fixed spacing.
7. Justification for reduced test configurations for WIFI channels per KDB Publication 248227 and April 2010 FCC/TCB Meeting Notes: Highest average RF output power channel for the lowest data rate were selected for SAR evaluation. Other IEEE 802.11 modes (including 802.11n) were not investigated since the average output powers were not greater than 0.25 dB than that of the corresponding channel in the lowest data rate IEEE 802.11b mode.
8. WLAN and Bluetooth transmission was verified using a spectrum analyzer.
9. Top and Left Edges were not required for WLAN since the antenna distance from the edge was greater than 2.5 cm per Oct 2010 TCB Workshop guidance (see Section 13.1).

FCC ID: A3LSGHT839			<b>SAR COMPLIANCE REPORT</b>	Reviewed by: Quality Manager
Filename: 0Y1102250383.A3L	Test Dates: 02/28/11 - 03/09/11	EUT Type: 850/1900 GSM/GPRS/EDGE and 1700 WCDMA/HSPA Phone with Bluetooth and WLAN		Page 32 of 45

# 16 FCC MULTI-TX AND ANTENNA SAR CONSIDERATIONS

## 16.1 Introduction

The following procedures adopted from “FCC SAR Considerations for Cell Phones with Multiple Transmitters” FCC KDB Publication 648474 are applicable to handsets with built-in unlicensed transmitters such as 802.11 a/b/g and Bluetooth devices which may simultaneously transmit with the licensed transmitter.

## 16.2 FCC Power Tables & Conditions

	2.45	5.15 - 5.35	5.47 - 5.85	GHz
$P_{Ref}$	12	6	5	mW
Device output power should be rounded to the nearest mW to compare with values specified in this table.				

**Figure 16-1**  
Output Power Thresholds for Unlicensed Transmitters

	Individual Transmitter	Simultaneous Transmission
<b>Licensed Transmitters</b>	<u>Routine evaluation required</u>	<b>SAR not required:</b> <u>Unlicensed only</u>
<b>Unlicensed Transmitters</b>	<p><b>When there is no simultaneous transmission –</b></p> <ul style="list-style-type: none"> <li>output <math>\leq 60/f</math>: SAR not required</li> <li>output <math>&gt; 60/f</math>: stand-alone SAR required</li> </ul> <p><b>When there is simultaneous transmission –</b> <u>Stand-alone SAR not required when</u></p> <ul style="list-style-type: none"> <li>output <math>\leq 2 \cdot P_{Ref}</math> and antenna is <math>\geq 5.0</math> cm from other antennas</li> <li>output <math>\leq P_{Ref}</math> and antenna is <math>\geq 2.5</math> cm from other antennas</li> <li>output <math>\leq P_{Ref}</math> and antenna is <math>&lt; 2.5</math> cm from other antennas, each with either output power <math>\leq P_{Ref}</math> or 1-g SAR <math>&lt; 1.2</math> W/kg</li> </ul> <p><u>Otherwise stand-alone SAR is required</u></p> <p><b>When stand-alone SAR is required</b></p> <ul style="list-style-type: none"> <li>test SAR on highest output channel for each wireless mode and exposure condition</li> <li>if SAR for highest output channel is <math>&gt; 50\%</math> of SAR limit, evaluate all channels according to normal procedures</li> </ul>	<ul style="list-style-type: none"> <li>when stand-alone 1-g SAR is not required and antenna is <math>\geq 5</math> cm from other antennas</li> </ul> <p><u>Licensed &amp; Unlicensed</u></p> <ul style="list-style-type: none"> <li>when the sum of the 1-g SAR is <math>&lt; 1.6</math> W/kg for all simultaneous transmitting antennas</li> <li>when SAR to peak location separation ratio of simultaneous transmitting antenna pair is <math>&lt; 0.3</math></li> </ul> <p><b>SAR required:</b> <u>Licensed &amp; Unlicensed</u></p> <p>antenna pairs with SAR to peak location separation ratio <math>\geq 0.3</math>; test is only required for the configuration that results in the highest SAR in stand-alone configuration for each wireless mode and exposure condition</p> <p><b>Note: simultaneous transmission exposure conditions for head and body can be different for different style phones; therefore, different test requirements may apply</b></p>

**Figure 16-2**  
SAR Evaluation Requirements for Multiple Transmitter Handsets

## 16.3 Multiple Antenna/Transmission Information for SGH-T839

The separation between the main antenna and the Bluetooth and WLAN antennas is 1.6 mm. RF Conducted Power of Bluetooth Tx is 17.865 mW. RF Conducted Power of WLAN is 58.076 mW.

## 16.4 Conclusion

Based on the output power, antenna separation distance and the Body SAR of the dominant transmitter, stand-alone Bluetooth and WLAN SAR tests are required.

FCC ID: A3LSGHT839		 PCTEST ENGINEERING LABORATORY, INC.		SAR COMPLIANCE REPORT		Reviewed by: Quality Manager	
Filename:	Test Dates:	EUT Type:					
0Y1102250383.A3L	02/28/11 - 03/09/11	850/1900 GSM/GPRS/EDGE and 1700 WCDMA/HSPA Phone with Bluetooth and WLAN					
						Page 33 of 45	

## 16.5 Simultaneous Transmission Evaluation

**Table 16-1**  
Simultaneous Transmission Summation for Held to Ear Voice Call with Hotspot Active Scenario

Simult Tx	Configuration	850 GSM SAR (W/kg)	WLAN SAR (W/kg)	Σ SAR (W/kg)
Head SAR	Right Cheek	0.133	0.323	<b>0.456</b>
	Right Tilt	0.099	0.093	<b>0.192</b>
	Left Cheek	0.137	0.210	<b>0.347</b>
	Left Tilt	0.088	0.172	<b>0.260</b>

Simult Tx	Configuration	GSM 1900 SAR (W/kg)	WIFI SAR (W/kg)	Σ SAR (W/kg)	Simult Tx	Configuration	UMTS IV SAR (W/kg)	WIFI SAR (W/kg)	Σ SAR (W/kg)
Head SAR	Right Touch	0.148	0.323	<b>0.471</b>	Head SAR	Right Cheek	0.254	0.323	<b>0.577</b>
	Left Touch	0.128	0.093	<b>0.221</b>		Right Tilt	0.256	0.093	<b>0.349</b>
	Right Tilt	0.176	0.210	<b>0.386</b>		Left Cheek	0.335	0.210	<b>0.545</b>
	Left Tilt	0.114	0.172	<b>0.286</b>		Left Tilt	0.232	0.172	<b>0.404</b>

**Table 16-2**  
Simultaneous Transmission Summation for 2G/3G Data and WIFI Hotspot Active Scenario

Simult Tx	Configuration	GSM 850 SAR (W/kg)	WIFI SAR (W/kg)	Σ SAR (W/kg)
Body SAR	Back	0.963	0.542	<b>1.505</b>
	Front	0.386	0.048	<b>0.434</b>
	Top	-	-	<b>0.000</b>
	Bottom	0.068	0.019	<b>0.088</b>
	Right	0.455	0.156	<b>0.611</b>
	Left	0.363	-	<b>0.363</b>

Simult Tx	Configuration	GSM 1900 SAR (W/kg)	WIFI SAR (W/kg)	Σ SAR (W/kg)	Simult Tx	Configuration	UMTS IV SAR (W/kg)	WIFI SAR (W/kg)	Σ SAR (W/kg)
Body SAR	Back	0.682	0.542	<b>1.224</b>	Body SAR	Back	0.809	0.542	<b>1.351</b>
	Front	0.460	0.048	<b>0.508</b>		Front	0.466	0.048	<b>0.514</b>
	Top	-	-	<b>0.000</b>		Top	-	-	<b>0.000</b>
	Bottom	0.341	0.019	<b>0.360</b>		Bottom	0.341	0.019	<b>0.360</b>
	Right	0.202	0.156	<b>0.358</b>		Right	0.145	0.156	<b>0.301</b>
	Left	0.215	-	<b>0.215</b>		Left	0.197	-	<b>0.197</b>

**Table 16-3**  
Simultaneous Transmission Summation for 2G/3G Data and Bluetooth Scenario

Simult Tx	Mode	2G/3G SAR (W/kg)	Bluetooth SAR (W/kg)	Σ SAR (W/kg)
Body SAR	850 GSM	0.963	0.025	<b>0.988</b>
	1900 GSM	0.682	0.025	<b>0.707</b>
	1700 WCDMA	0.809	0.025	<b>0.834</b>

The above tables represent the worst-case simultaneous transmission scenarios possible with this device. Note: “-” SAR results shown in the table are zero for summation purposes. SAR was not required to be measured due to exclusions mentioned in Section 13.1.

The above numerical summed SAR was below the SAR limit. Therefore, the above analysis is sufficient to determine that simultaneous transmission cases will not exceed the SAR limit. Therefore, no volumetric SAR summation is required per FCC publication 648474 since the numerical sums are below the limit.

# 17 EQUIPMENT LIST

Manufacturer	Model	Description	Cal Date	Cal Interval	Cal Due	Serial Number
Agilent	85070B	Dielectric Probe Kit	8/22/2010	Annual	8/22/2011	US33020316
Agilent	8648D	(9kHz-4GHz) Signal Generator	10/13/2010	Annual	10/13/2011	3613A00315
Agilent	8753E	(30kHz-6GHz) Network Analyzer	3/31/2010	Annual	3/31/2011	JP38020182
Agilent	E5515C	Wireless Communications Test Set	10/11/2010	Annual	10/11/2011	GB46110872
Agilent	E5515C	Wireless Communications Test Set	10/8/2010	Annual	10/8/2011	GB46310798
Agilent	E5515C	Wireless Communications Test Set	8/13/2010	Annual	8/13/2011	GB41450275
Agilent	E8257D	(250kHz-20GHz) Signal Generator	3/30/2010	Annual	3/30/2011	MY45470194
Gigatronics	80701A	(0.05-18GHz) Power Sensor	10/11/2010	Annual	10/11/2011	1833460
Gigatronics	8651A	Universal Power Meter	10/11/2010	Annual	10/11/2011	8650319
Index SAR	IXTL-010	Dielectric Measurement Kit	N/A		N/A	N/A
Index SAR	IXTL-030	30MM TEM line for 6 GHz	N/A		N/A	N/A
Pasternack	PE2208-6	Bidirectional Coupler	N/A		N/A	N/A
Pasternack	PE2209-10	Bidirectional Coupler	N/A		N/A	N/A
Rohde & Schwarz	CMU200	Base Station Simulator	11/11/2010	Annual	11/11/2011	836371/0079
Rohde & Schwarz	CMU200	Base Station Simulator	6/21/2010	Annual	6/21/2011	833855/0010
SPEAG	D1450V2	1450 MHz SAR Dipole	5/20/2009	Biennial	5/20/2011	1025
SPEAG	D1765V2	1765 MHz SAR Dipole	5/19/2009	Biennial	5/19/2011	1008
SPEAG	D1900V2	1900 MHz SAR Dipole	2/17/2011	Annual	2/17/2012	502
SPEAG	D1900V2	1900 MHz SAR Dipole	8/18/2009	Biennial	8/18/2011	5d080
SPEAG	D2450V2	2450 MHz SAR Dipole	8/27/2009	Biennial	8/27/2011	719
SPEAG	D2600V2	2600 MHz SAR Dipole	8/12/2009	Biennial	8/12/2011	1004
SPEAG	D5GHzV2	5 GHz SAR Dipole	8/19/2009	Biennial	8/19/2011	1007
SPEAG	D5GHzV2	5 GHz SAR Dipole	2/11/2011	Annual	2/11/2012	1057
SPEAG	D835V2	835 MHz SAR Dipole	2/9/2011	Annual	2/9/2012	4d047
SPEAG	D835V2	835 MHz SAR Dipole	8/24/2009	Biennial	8/24/2011	4d026
SPEAG	DAE3	Dasy Data Acquisition Electronics	11/18/2010	Annual	11/18/2011	455
SPEAG	DAE4	Dasy Data Acquisition Electronics	3/22/2010	Annual	3/22/2011	704
SPEAG	DAE4	Dasy Data Acquisition Electronics	4/21/2010	Annual	4/21/2011	665
SPEAG	DAE4	Dasy Data Acquisition Electronics	2/21/2011	Annual	2/21/2012	649
SPEAG	ES3DV2	SAR Probe	9/21/2010	Annual	9/21/2011	3022
SPEAG	EX3DV4	SAR Probe	8/19/2010	Annual	8/19/2011	3561
SPEAG	EX3DV4	SAR Probe	2/14/2011	Annual	2/14/2012	3550
SPEAG	DAE4	Dasy Data Acquisition Electronics	7/8/2010	Annual	7/8/2011	859
SPEAG	D750V3	750 MHz Dipole	2/14/2011	Biennial	2/14/2013	1003
SPEAG	ES3DV3	SAR Probe	3/16/2010	Annual	3/16/2011	3213
SPEAG	ES3DV3	SAR Probe	4/20/2010	Annual	4/20/2011	3209
Rohde & Schwarz	SMIQ03B	Signal Generator	4/1/2010	Annual	4/1/2011	DE27259
SPEAG	D1640V2	1640 MHz Dipole	8/17/2010	Biennial	8/17/2012	321
Rohde & Schwarz	CMW500	LTE Radio Communication Tester	8/30/2010	Annual	8/30/2011	100976
Agilent	8648D	Signal Generator	4/1/2010	Annual	4/1/2011	3629U00687
Aprl	ALS-PR-DIEL	Dielectric Probe Kit	N/A		N/A	260-00959
Agilent	E5515C	Wireless Communications Test Set	8/13/2010	Annual	8/13/2011	GB43304447
Agilent	E5515C	Wireless Communications Tester	4/14/2010	Annual	4/14/2011	US41140256
Amplifier Research	5S1G4	5W, 800MHz-4.2GHz	N/A			17042
Mini-Circuits	BW-N20W5+	DC to 18 GHz Precision Fixed 20 dB Attenuator	N/A			N/A
Agilent	E5515C	Wireless Communications Test Set	2/8/2011	Annual	2/8/2012	GB45360985

Justification for 2-year calibration cycle for SAR dipoles is found in Section 14.3.

FCC ID: A3LSGHT839		 <b>SAR COMPLIANCE REPORT</b>		Reviewed by: Quality Manager
Filename: 0Y1102250383.A3L	Test Dates: 02/28/11 - 03/09/11	EUT Type: 850/1900 GSM/GPRS/EDGE and 1700 WCDMA/HSPA Phone with Bluetooth and WLAN		Page 35 of 45
© 2011 PCTEST Engineering Laboratory, Inc.				REV 8.8M 01/04/2011

# 18 MEASUREMENT UNCERTAINTIES

Applicable for 800 – 3000 MHz.

a	b	c	d	e= f(d,k)	f	g	h = c x f/e	i = c x g/e	k
Uncertainty Component	IEEE 1528 Sec.	Tol. (± %)	Prob. Dist.	Div.	c <sub>i</sub> 1gm	c <sub>i</sub> 10 gms	1gm u <sub>i</sub> (± %)	10gms u <sub>i</sub> (± %)	v <sub>i</sub>
<b>Measurement System</b>									
Probe Calibration	E.2.1	5.5	N	1	1.0	1.0	5.5	5.5	∞
Axial Isotropy	E.2.2	0.25	N	1	0.7	0.7	0.2	0.2	∞
Hemishperical Isotropy	E.2.2	1.3	N	1	1.0	1.0	1.3	1.3	∞
Boundary Effect	E.2.3	0.4	N	1	1.0	1.0	0.4	0.4	∞
Linearity	E.2.4	0.3	N	1	1.0	1.0	0.3	0.3	∞
System Detection Limits	E.2.5	5.1	N	1	1.0	1.0	5.1	5.1	∞
Readout Electronics	E.2.6	1.0	N	1	1.0	1.0	1.0	1.0	∞
Response Time	E.2.7	0.8	R	1.73	1.0	1.0	0.5	0.5	∞
Integration Time	E.2.8	2.6	R	1.73	1.0	1.0	1.5	1.5	∞
RF Ambient Conditions	E.6.1	3.0	R	1.73	1.0	1.0	1.7	1.7	∞
Probe Positioner Mechanical Tolerance	E.6.2	0.4	R	1.73	1.0	1.0	0.2	0.2	∞
Probe Positioning w/ respect to Phantom	E.6.3	2.9	R	1.73	1.0	1.0	1.7	1.7	∞
Extrapolation, Interpolation & Integration algorithms for Max. SAR Evaluation	E.5	1.0	R	1.73	1.0	1.0	0.6	0.6	∞
<b>Test Sample Related</b>									
Test Sample Positioning	E.4.2	6.0	N	1	1.0	1.0	6.0	6.0	287
Device Holder Uncertainty	E.4.1	3.32	R	1.73	1.0	1.0	1.9	1.9	∞
Output Power Variation - SAR drift measurement	6.6.2	5.0	R	1.73	1.0	1.0	2.9	2.9	∞
<b>Phantom &amp; Tissue Parameters</b>									
Phantom Uncertainty (Shape & Thickness tolerances)	E.3.1	4.0	R	1.73	1.0	1.0	2.3	2.3	∞
Liquid Conductivity - deviation from target values	E.3.2	5.0	R	1.73	0.64	0.43	1.8	1.2	∞
Liquid Conductivity - measurement uncertainty	E.3.3	3.8	N	1	0.64	0.43	2.4	1.6	6
Liquid Permittivity - deviation from target values	E.3.2	5.0	R	1.73	0.60	0.49	1.7	1.4	∞
Liquid Permittivity - measurement uncertainty	E.3.3	4.5	N	1	0.60	0.49	2.7	2.2	6
<b>Combined Standard Uncertainty (k=1)</b>				RSS			11.8	11.5	299
<b>Expanded Uncertainty (95% CONFIDENCE LEVEL)</b>				k=2			23.7	23.0	

The above measurement uncertainties are according to IEEE Std. 1528-2003

# 19 CONCLUSION

## 19.1 Measurement Conclusion

The SAR evaluation indicates that the EUT complies with the RF radiation exposure limits of the FCC and Industry Canada, with respect to all parameters subject to this test. These measurements were taken to simulate the RF effects of RF exposure under worst-case conditions. Precise laboratory measures were taken to assure repeatability of the tests. The results and statements relate only to the item(s) tested.

Please note that the absorption and distribution of electromagnetic energy in the body are very complex phenomena that depend on the mass, shape, and size of the body, the orientation of the body with respect to the field vectors, and the electrical properties of both the body and the environment. Other variables that may play a substantial role in possible biological effects are those that characterize the environment (e.g. ambient temperature, air velocity, relative humidity, and body insulation) and those that characterize the individual (e.g. age, gender, activity level, debilitation, or disease). Because various factors may interact with one another to vary the specific biological outcome of an exposure to electromagnetic fields, any protection guide should consider maximal amplification of biological effects as a result of field-body interactions, environmental conditions, and physiological variables. [3]

FCC ID: A3LSGHT839		 <b>PCTEST</b> <small>ENGINEERING LABORATORY, INC.</small>		SAR COMPLIANCE REPORT		Reviewed by: Quality Manager	
Filename:	Test Dates:	EUT Type:		Page 37 of 45			
0Y1102250383.A3L	02/28/11 - 03/09/11	850/1900 GSM/GPRS/EDGE and 1700 WCDMA/HSPA Phone with Bluetooth and WLAN					

- [1] Federal Communications Commission, ET Docket 93-62, Guidelines for Evaluating the Environmental Effects of Radiofrequency Radiation, Aug. 1996.
- [2] ANSI/IEEE C95.1-2005, American National Standard safety levels with respect to human exposure to radio frequency electromagnetic fields, 300kHz to 100GHz, New York: IEEE, 2006.
- [3] ANSI/IEEE C95.1-1992, American National Standard safety levels with respect to human exposure to radio frequency electromagnetic fields, 300kHz to 100GHz, New York: IEEE, Sept. 1992.
- [4] ANSI/IEEE C95.3-2002, IEEE Recommended Practice for the Measurement of Potentially Hazardous Electromagnetic Fields - RF and Microwave, New York: IEEE, December 2002.
- [5] Federal Communications Commission, OET Bulletin 65 (Edition 97-01), Supplement C (Edition 01-01), Evaluating Compliance with FCC Guidelines for Human Exposure to Radiofrequency Electromagnetic Fields, June 2001.
- [6] IEEE Standards Coordinating Committee 34 – IEEE Std. 1528-2003, Recommended Practice for Determining the Peak Spatial-Average Specific Absorption Rate (SAR) in the Human Body Due to Wireless Communications Devices.
- [7] NCRP, National Council on Radiation Protection and Measurements, Biological Effects and Exposure Criteria for RadioFrequency Electromagnetic Fields, NCRP Report No. 86, 1986. Reprinted Feb. 1995.
- [8] T. Schmid, O. Egger, N. Kuster, Automated E-field scanning system for dosimetric assessments, IEEE Transaction on Microwave Theory and Techniques, vol. 44, Jan. 1996, pp. 105-113.
- [9] K. Pokovic, T. Schmid, N. Kuster, Robust setup for precise calibration of E-field probes in tissue simulating liquids at mobile communications frequencies, ICECOM97, Oct. 1997, pp. 120-124.
- [10] K. Pokovic, T. Schmid, and N. Kuster, E-field Probe with improved isotropy in brain simulating liquids, Proceedings of the ELMAR, Zadar, Croatia, June 23-25, 1996, pp. 172-175.
- [11] Schmid & Partner Engineering AG, Application Note: Data Storage and Evaluation, June 1998, p2.
- [12] V. Hombach, K. Meier, M. Burkhardt, E. Kuhn, N. Kuster, The Dependence of EM Energy Absorption upon Human Head Modeling at 900 MHz, IEEE Transaction on Microwave Theory and Techniques, vol. 44 no. 10, Oct. 1996, pp. 1865-1873.
- [13] N. Kuster and Q. Balzano, Energy absorption mechanism by biological bodies in the near field of dipole antennas above 300MHz, IEEE Transaction on Vehicular Technology, vol. 41, no. 1, Feb. 1992, pp. 17-23.
- [14] G. Hartsgrrove, A. Kraszewski, A. Surowiec, Simulated Biological Materials for Electromagnetic Radiation Absorption Studies, University of Ottawa, Bioelectromagnetics, Canada: 1987, pp. 29-36.
- [15] Q. Balzano, O. Garay, T. Manning Jr., Electromagnetic Energy Exposure of Simulated Users of Portable Cellular Telephones, IEEE Transactions on Vehicular Technology, vol. 44, no.3, Aug. 1995.

FCC ID: A3LSGHT839		 <b>SAR COMPLIANCE REPORT</b>		Reviewed by: Quality Manager
Filename: 0Y1102250383.A3L	Test Dates: 02/28/11 - 03/09/11	EUT Type: 850/1900 GSM/GPRS/EDGE and 1700 WCDMA/HSPA Phone with Bluetooth and WLAN		Page 38 of 45

- [16] W. Gander, Computermathematick, Birkhaeuser, Basel, 1992.
- [17] W.H. Press, S.A. Teukolsky, W.T. Vetterling, and B.P. Flannery, Numerical Receptions in C, The Art of Scientific Computing, Second edition, Cambridge University Press, 1992.
- [18] Federal Communications Commission, OET Bulletin 65, Evaluating Compliance with FCC Guidelines for Human Exposure to Radiofrequency Electromagnetic Fields. Supplement C, Dec. 1997.
- [19] N. Kuster, R. Kastle, T. Schmid, Dosimetric evaluation of mobile communications equipment with known precision, IEEE Transaction on Communications, vol. E80-B, no. 5, May 1997, pp. 645-652.
- [20] CENELEC CLC/SC111B, European Prestandard (prENV 50166-2), Human Exposure to Electromagnetic Fields High-frequency: 10kHz-300GHz, Jan. 1995.
- [21] Prof. Dr. Niels Kuster, ETH, Eidgenössische Technische Hochschule Zürich, Dosimetric Evaluation of the Cellular Phone.
- [22] IEC 62209-1, Human exposure to radio frequency fields from hand-held and body-mounted wireless communication devices - Human models, instrumentation, and procedures - Part 1: Procedure to determine the specific absorption rate (SAR) for hand-held devices used in close proximity to the ear (frequency range of 300 MHz to 3 GHz), Feb. 2005.
- [23] Industry Canada RSS-102 Radio Frequency Exposure Compliance of Radiocommunication Apparatus (All Frequency Bands) Issue 4, March 2010.
- [24] Health Canada Safety Code 6 Limits of Human Exposure to Radio Frequency Electromagnetic Fields in the Frequency Range from 3 kHz – 300 GHz, 2009
- [25] FCC Public Notice DA-02-1438. Office of Engineering and Technology Announces a Transition Period for the Phantom Requirements of Supplement C to OET Bulletin 65, June 19, 2002
- [26] FCC SAR Measurement Procedures for 3G Devices KDB Publication 941225
- [27] SAR Measurement procedures for IEEE 802.11a/b/g KDB Publication 248227
- [28] FCC SAR Considerations for Handsets with Multiple Transmitters and Antennas, KDB Publication 648474
- [29] FCC Application Note for SAR Probe Calibration and System Verification Consideration for Measurements at 150 MHz – 3 GHz, KDB Publication 450824
- [30] FCC SAR Evaluation Considerations for Laptop Computers with Antennas Built-in on Display Screens, KDB Publication 616217
- [31] FCC SAR Measurement Requirements for 3 – 6 GHz, KDB Publication 865664
- [32] FCC Mobile Portable RF Exposure Procedure, KDB Publication 447498
- [33] FCC SAR Procedures for Dongle Transmitters, KDB Publication 447498
- [34] Anexo à Resolução No. 533, de 10 de Setembro de 2009.
- [35] FCC SAR Test Considerations for LTE Handsets and Data Modems, KDB Publication 941225

FCC ID: A3LSGHT839		 <b>PCTEST</b> ENGINEERING LABORATORY, INC.		SAR COMPLIANCE REPORT		Reviewed by: Quality Manager	
Filename:	Test Dates:	EUT Type:		850/1900 GSM/GPRS/EDGE and 1700 WCDMA/HSPA Phone with Bluetooth and WLAN		Page 39 of 45	
0Y1102250383.A3L		02/28/11 - 03/09/11					

## **APPENDIX A: SAR TEST DATA**

# PCTEST ENGINEERING LABORATORY, INC.

**DUT: A3LSGHT839; Type: 850/1900 GSM/GPRS/EDGE and 1700 WCDMA/HSPA Phone with Bluetooth and WLAN; Serial: FI-035-A**

Communication System: GSM850; Frequency: 836.6 MHz; Duty Cycle: 1:8.3

Medium: 835 Head Medium parameters used (interpolated):

$f = 836.6 \text{ MHz}$ ;  $\sigma = 0.887 \text{ mho/m}$ ;  $\epsilon_r = 42.6$ ;  $\rho = 1000 \text{ kg/m}^3$

Phantom section: Right Section

Test Date: 02-28-2011; Ambient Temp: 23.8 °C; Tissue Temp: 21.9 °C

Probe: ES3DV2 - SN3022; ConvF(6.02, 6.02, 6.02); Calibrated: 9/21/2010

Sensor-Surface: 4mm (Mechanical Surface Detection)

Electronics: DAE4 Sn704; Calibrated: 3/22/2010

Phantom: SAM Main; Type: SAM 4.0; Serial: TP-1406

Measurement SW: DASY4, V4.7 Build 80; Postprocessing SW: SEMCAD, V1.8 Build 186

**Mode: GSM 850, Right Head, Touch, Mid.ch**

**Area Scan (7x14x1):** Measurement grid: dx=15mm, dy=15mm

**Zoom Scan (5x5x7)/Cube 0:** Measurement grid: dx=8mm, dy=8mm, dz=5mm

Reference Value = 12.4 V/m

Peak SAR (extrapolated) = 0.159 W/kg

**SAR(1 g) = 0.133 mW/g; SAR(10 g) = 0.107 mW/g**

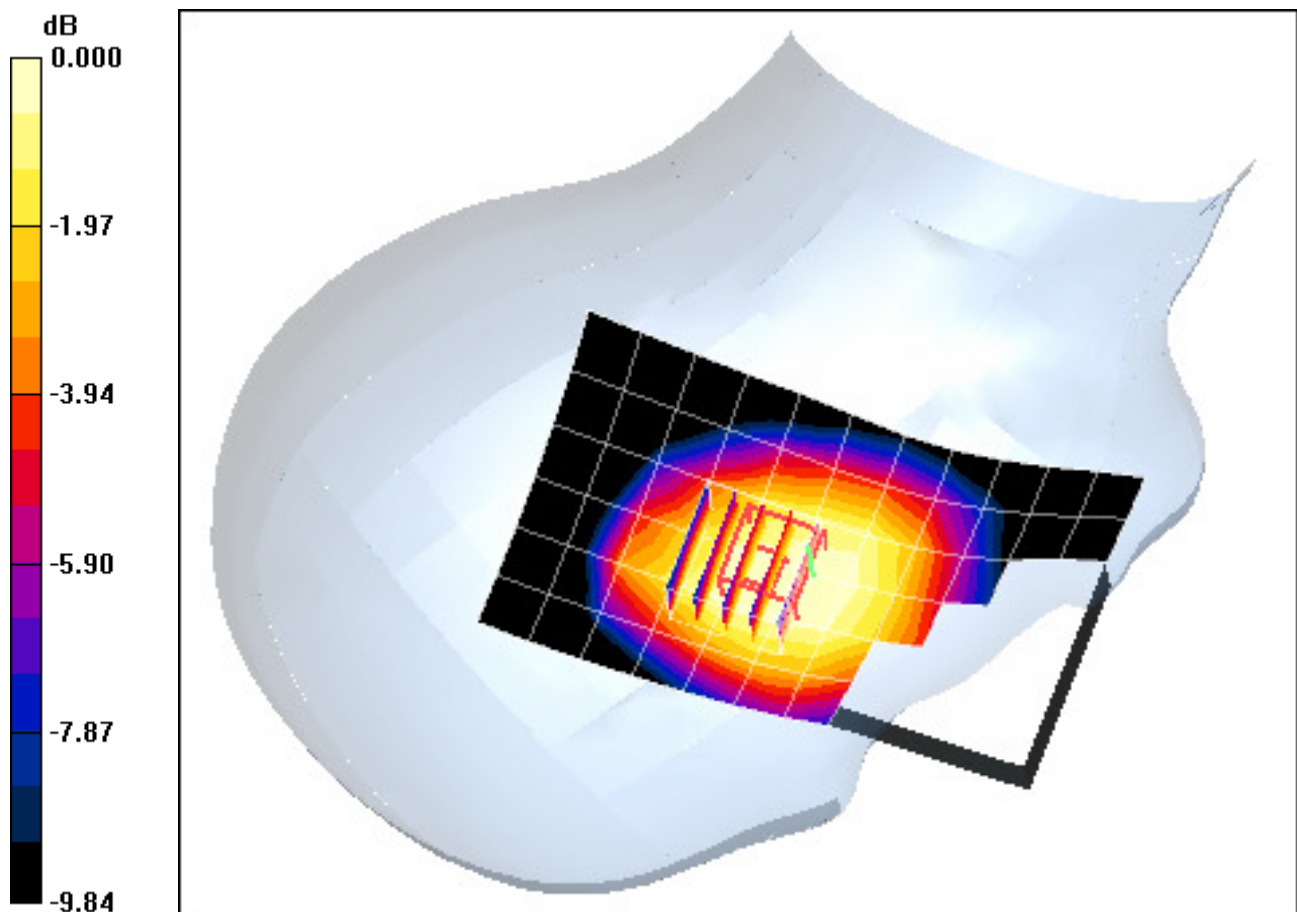

0 dB = 0.138mW/g

# PCTEST ENGINEERING LABORATORY, INC.

**DUT: A3LSGHT839; Type: 850/1900 GSM/GPRS/EDGE and 1700 WCDMA/HSPA Phone with Bluetooth and WLAN; Serial: FI-035-A**

Communication System: GSM850; Frequency: 836.6 MHz; Duty Cycle: 1:8.3

Medium: 835 Head Medium parameters used (interpolated):

$f = 836.6 \text{ MHz}$ ;  $\sigma = 0.887 \text{ mho/m}$ ;  $\epsilon_r = 42.6$ ;  $\rho = 1000 \text{ kg/m}^3$

Phantom section: Right Section

Test Date: 02-28-2011; Ambient Temp: 23.8 °C; Tissue Temp: 21.9 °C

Probe: ES3DV2 - SN3022; ConvF(6.02, 6.02, 6.02); Calibrated: 9/21/2010

Sensor-Surface: 4mm (Mechanical Surface Detection)

Electronics: DAE4 Sn704; Calibrated: 3/22/2010

Phantom: SAM Main; Type: SAM 4.0; Serial: TP-1406

Measurement SW: DASY4, V4.7 Build 80; Postprocessing SW: SEMCAD, V1.8 Build 186

**Mode: GSM 850, Right Head, Tilt, Mid.ch**

**Area Scan (7x14x1):** Measurement grid: dx=15mm, dy=15mm

**Zoom Scan (5x5x7)/Cube 0:** Measurement grid: dx=8mm, dy=8mm, dz=5mm

Reference Value = 11.0 V/m

Peak SAR (extrapolated) = 0.125 W/kg

**SAR(1 g) = 0.099 mW/g; SAR(10 g) = 0.075 mW/g**

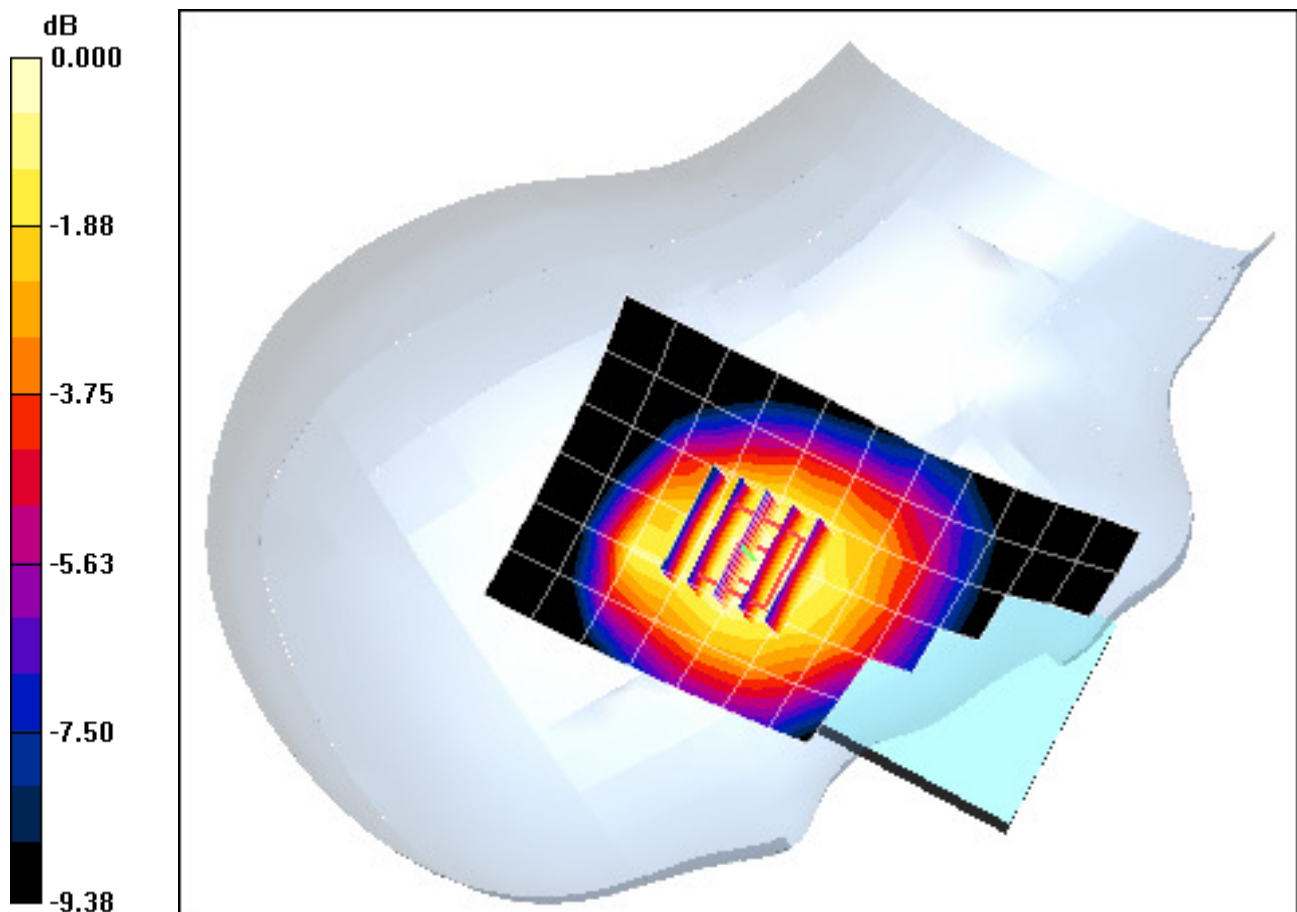

0 dB = 0.105mW/g

# PCTEST ENGINEERING LABORATORY, INC.

**DUT: A3LSGHT839; Type: 850/1900 GSM/GPRS/EDGE and 1700 WCDMA/HSPA Phone with Bluetooth and WLAN; Serial: FI-035-A**

Communication System: GSM850; Frequency: 836.6 MHz; Duty Cycle: 1:8.3  
Medium: 835 Head Medium parameters used (interpolated):  
 $f = 836.6 \text{ MHz}$ ;  $\sigma = 0.887 \text{ mho/m}$ ;  $\epsilon_r = 42.6$ ;  $\rho = 1000 \text{ kg/m}^3$   
Phantom section: Left Section

Test Date: 02-28-2011; Ambient Temp: 23.8 °C; Tissue Temp: 21.9 °C

Probe: ES3DV2 - SN3022; ConvF(6.02, 6.02, 6.02); Calibrated: 9/21/2010  
Sensor-Surface: 4mm (Mechanical Surface Detection)  
Electronics: DAE4 Sn704; Calibrated: 3/22/2010  
Phantom: SAM Main; Type: SAM 4.0; Serial: TP-1406  
Measurement SW: DASY4, V4.7 Build 80; Postprocessing SW: SEMCAD, V1.8 Build 186

**Mode: GSM 850, Left Head, Touch, Mid.ch**

**Area Scan (7x14x1):** Measurement grid: dx=15mm, dy=15mm  
**Zoom Scan (5x5x7)/Cube 0:** Measurement grid: dx=8mm, dy=8mm, dz=5mm  
Reference Value = 12.7 V/m  
Peak SAR (extrapolated) = 0.163 W/kg  
**SAR(1 g) = 0.137 mW/g; SAR(10 g) = 0.109 mW/g**

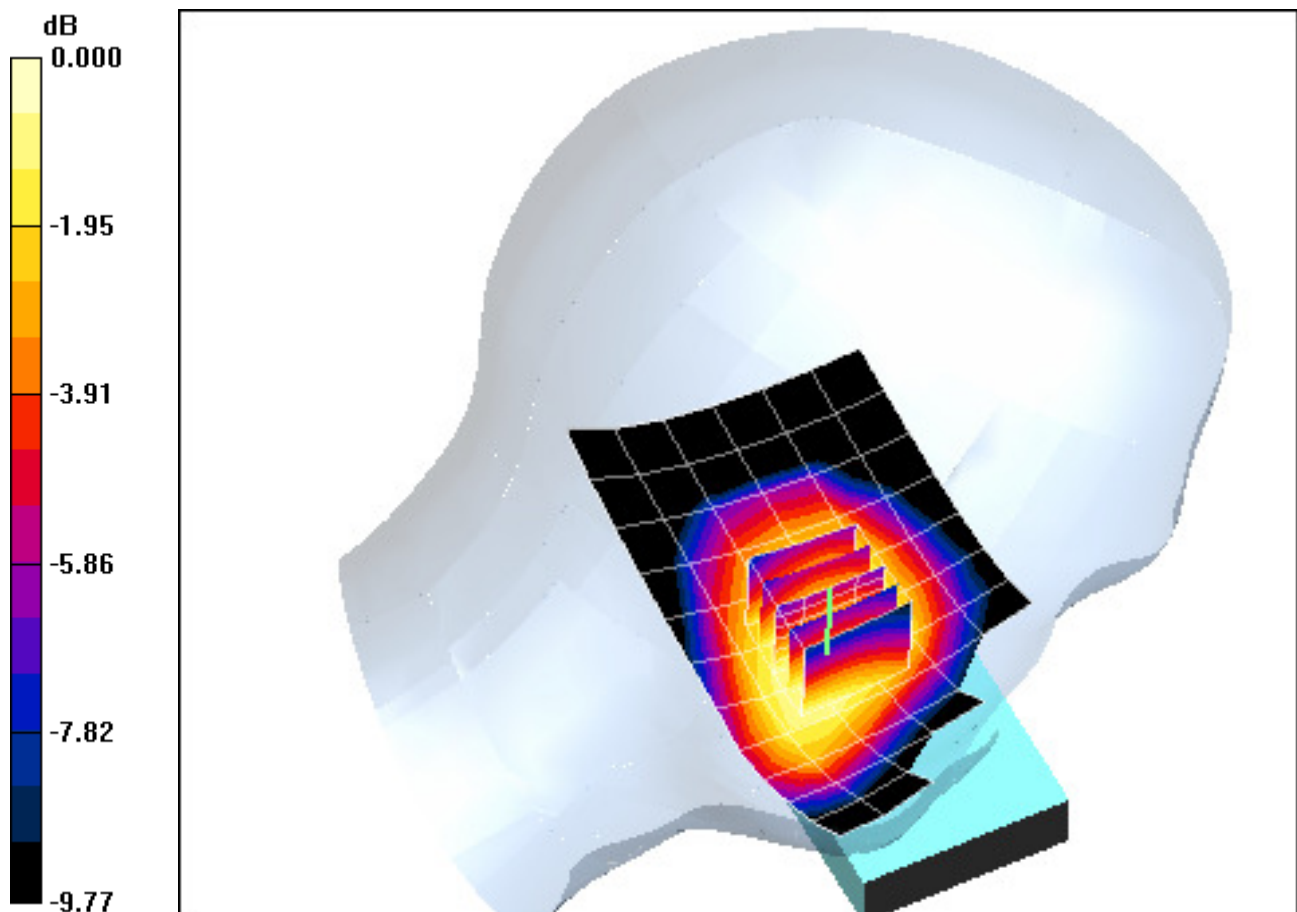

0 dB = 0.142mW/g

# PCTEST ENGINEERING LABORATORY, INC.

**DUT: A3LSGHT839; Type: 850/1900 GSM/GPRS/EDGE and 1700 WCDMA/HSPA Phone with Bluetooth and WLAN; Serial: FI-035-A**

Communication System: GSM850; Frequency: 836.6 MHz; Duty Cycle: 1:8.3  
Medium: 835 Head Medium parameters used (interpolated):  
 $f = 836.6 \text{ MHz}$ ;  $\sigma = 0.887 \text{ mho/m}$ ;  $\epsilon_r = 42.6$ ;  $\rho = 1000 \text{ kg/m}^3$   
Phantom section: Left Section

Test Date: 02-28-2011; Ambient Temp: 23.8 °C; Tissue Temp: 21.9 °C

Probe: ES3DV2 - SN3022; ConvF(6.02, 6.02, 6.02); Calibrated: 9/21/2010  
Sensor-Surface: 4mm (Mechanical Surface Detection)  
Electronics: DAE4 Sn704; Calibrated: 3/22/2010  
Phantom: SAM Main; Type: SAM 4.0; Serial: TP-1406  
Measurement SW: DASY4, V4.7 Build 80; Postprocessing SW: SEMCAD, V1.8 Build 186

**Mode: GSM 850, Left Head, Touch, Mid.ch**

**Area Scan (7x14x1):** Measurement grid: dx=15mm, dy=15mm  
**Zoom Scan (5x5x7)/Cube 0:** Measurement grid: dx=8mm, dy=8mm, dz=5mm  
Reference Value = 12.7 V/m  
Peak SAR (extrapolated) = 0.163 W/kg  
**SAR(1 g) = 0.137 mW/g; SAR(10 g) = 0.109 mW/g**

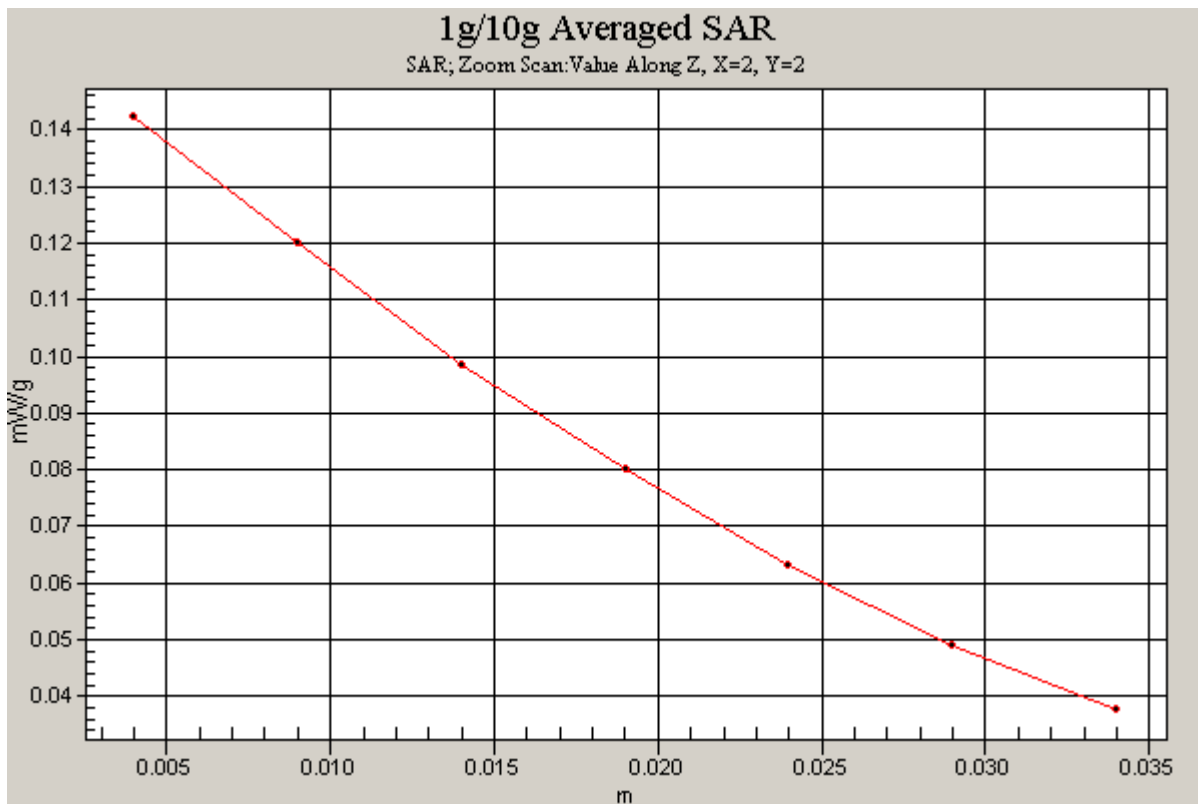

# PCTEST ENGINEERING LABORATORY, INC.

**DUT: A3LSGHT839; Type: 850/1900 GSM/GPRS/EDGE and 1700 WCDMA/HSPA Phone with Bluetooth and WLAN; Serial: FI-035-A**

Communication System: GSM850; Frequency: 836.6 MHz; Duty Cycle: 1:8.3  
Medium: 835 Head Medium parameters used (interpolated):  
 $f = 836.6 \text{ MHz}$ ;  $\sigma = 0.887 \text{ mho/m}$ ;  $\epsilon_r = 42.6$ ;  $\rho = 1000 \text{ kg/m}^3$   
Phantom section: Left Section

Test Date: 02-28-2011; Ambient Temp: 23.8 °C; Tissue Temp: 21.9 °C

Probe: ES3DV2 - SN3022; ConvF(6.02, 6.02, 6.02); Calibrated: 9/21/2010  
Sensor-Surface: 4mm (Mechanical Surface Detection)  
Electronics: DAE4 Sn704; Calibrated: 3/22/2010  
Phantom: SAM Main; Type: SAM 4.0; Serial: TP-1406  
Measurement SW: DASY4, V4.7 Build 80; Postprocessing SW: SEMCAD, V1.8 Build 186

**Mode: GSM 850, Left Head, Tilt, Mid.ch**

**Area Scan (7x14x1):** Measurement grid: dx=15mm, dy=15mm  
**Zoom Scan (5x5x7)/Cube 0:** Measurement grid: dx=8mm, dy=8mm, dz=5mm  
Reference Value = 10.3 V/m  
Peak SAR (extrapolated) = 0.109 W/kg  
**SAR(1 g) = 0.088 mW/g; SAR(10 g) = 0.066 mW/g**

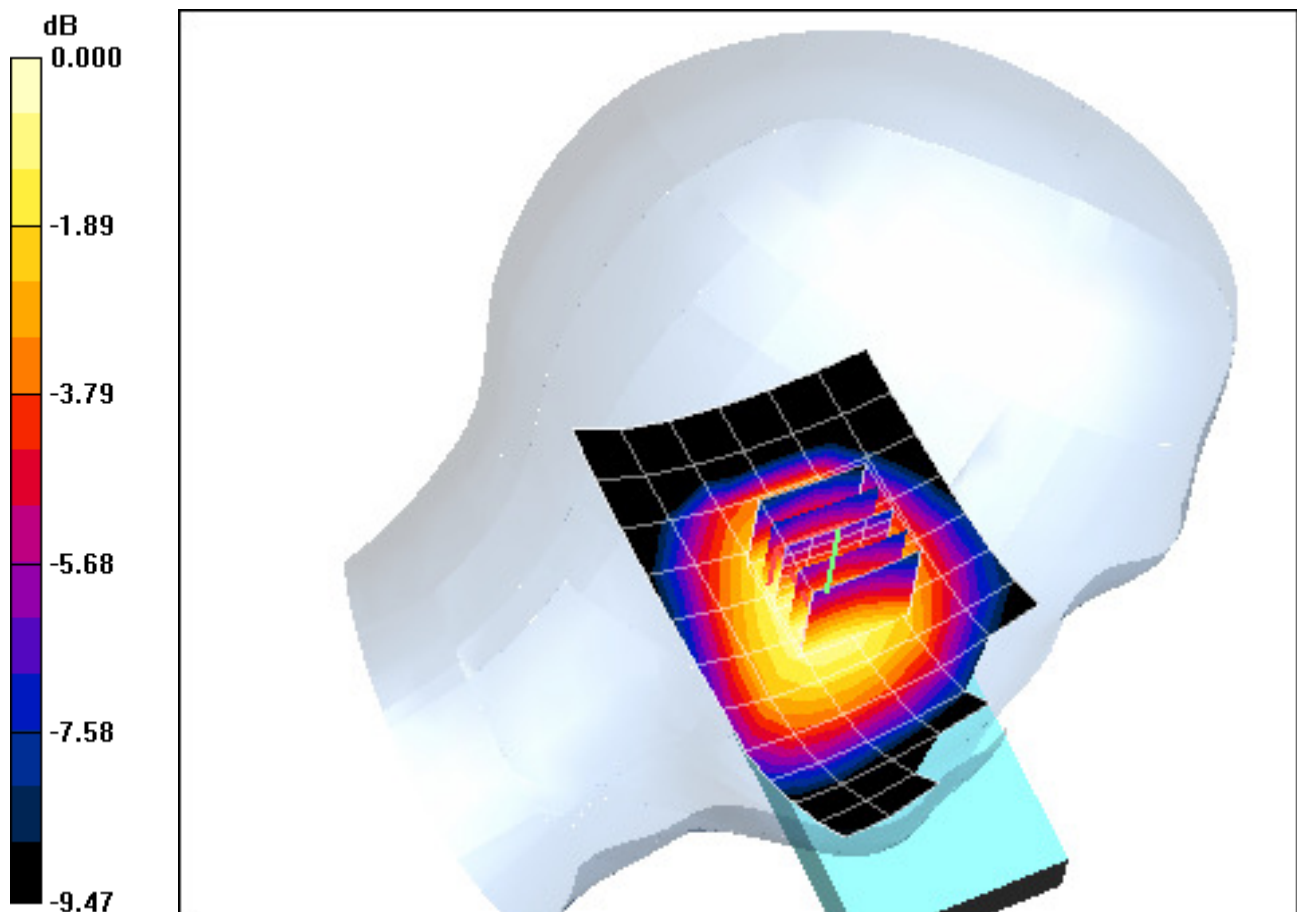

0 dB = 0.093mW/g

# PCTEST ENGINEERING LABORATORY, INC.

**DUT: A3LSGHT839; Type: 850/1900 GSM/GPRS/EDGE and 1700 WCDMA/HSPA Phone with Bluetooth and WLAN; Serial: FI-035-A**

Communication System: GSM1900; Frequency: 1880 MHz; Duty Cycle: 1:8.3

Medium: 1900 Head Medium parameters used:

$f = 1880 \text{ MHz}$ ;  $\sigma = 1.45 \text{ mho/m}$ ;  $\epsilon_r = 40.3$ ;  $\rho = 1000 \text{ kg/m}^3$

Phantom section: Right Section

Test Date: 03-02-2011; Ambient Temp: 24.2 °C; Tissue Temp: 22.5 °C

Probe: ES3DV2 - SN3022; ConvF(4.83, 4.83, 4.83); Calibrated: 9/21/2010

Sensor-Surface: 4mm (Mechanical Surface Detection)

Electronics: DAE4 Sn704; Calibrated: 3/22/2010

Phantom: SAM Main; Type: SAM 4.0; Serial: TP-1406

Measurement SW: DASY4, V4.7 Build 80; Postprocessing SW: SEMCAD, V1.8 Build 186

**Mode: GSM 1900, Right Head, Touch, Mid.ch**

**Area Scan (7x14x1):** Measurement grid: dx=15mm, dy=15mm

**Zoom Scan (5x5x7)/Cube 0:** Measurement grid: dx=8mm, dy=8mm, dz=5mm

Reference Value = 10.2 V/m

Peak SAR (extrapolated) = 0.222 W/kg

**SAR(1 g) = 0.148 mW/g; SAR(10 g) = 0.093 mW/g**

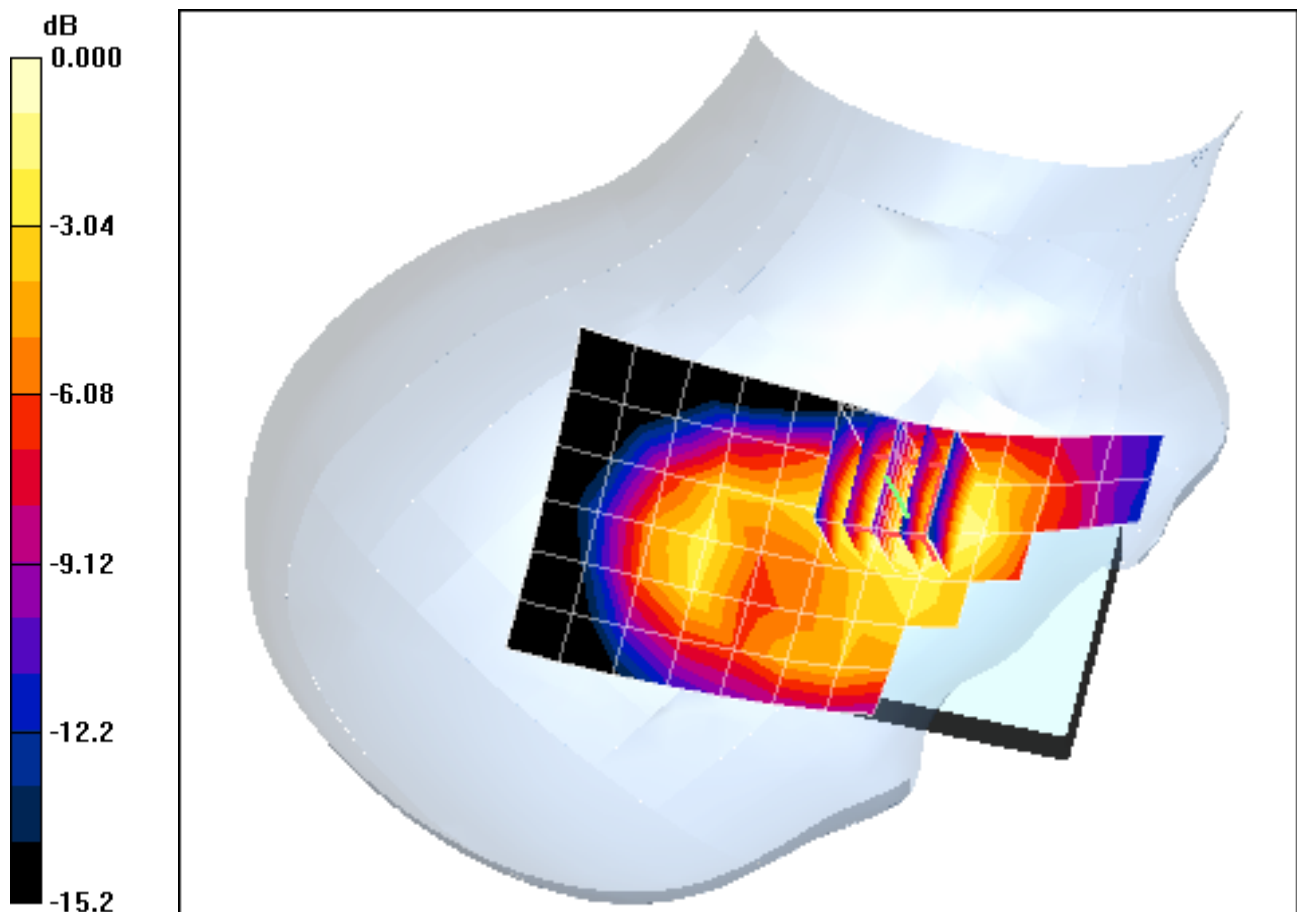

0 dB = 0.160mW/g

# PCTEST ENGINEERING LABORATORY, INC.

**DUT: A3LSGHT839; Type: 850/1900 GSM/GPRS/EDGE and 1700 WCDMA/HSPA Phone with Bluetooth and WLAN; Serial: FI-035-A**

Communication System: GSM1900; Frequency: 1880 MHz; Duty Cycle: 1:8.3

Medium: 1900 Head Medium parameters used:

$f = 1880 \text{ MHz}$ ;  $\sigma = 1.45 \text{ mho/m}$ ;  $\epsilon_r = 40.3$ ;  $\rho = 1000 \text{ kg/m}^3$

Phantom section: Right Section

Test Date: 03-02-2011; Ambient Temp: 24.2 °C; Tissue Temp: 22.5 °C

Probe: ES3DV2 - SN3022; ConvF(4.83, 4.83, 4.83); Calibrated: 9/21/2010

Sensor-Surface: 4mm (Mechanical Surface Detection)

Electronics: DAE4 Sn704; Calibrated: 3/22/2010

Phantom: SAM Main; Type: SAM 4.0; Serial: TP-1406

Measurement SW: DASY4, V4.7 Build 80; Postprocessing SW: SEMCAD, V1.8 Build 186

**Mode: GSM 1900, Right Head, Tilt, Mid.ch**

**Area Scan (7x14x1):** Measurement grid: dx=15mm, dy=15mm

**Zoom Scan (5x5x7)/Cube 0:** Measurement grid: dx=8mm, dy=8mm, dz=5mm

Reference Value = 9.62 V/m

Peak SAR (extrapolated) = 0.205 W/kg

**SAR(1 g) = 0.128 mW/g; SAR(10 g) = 0.074 mW/g**

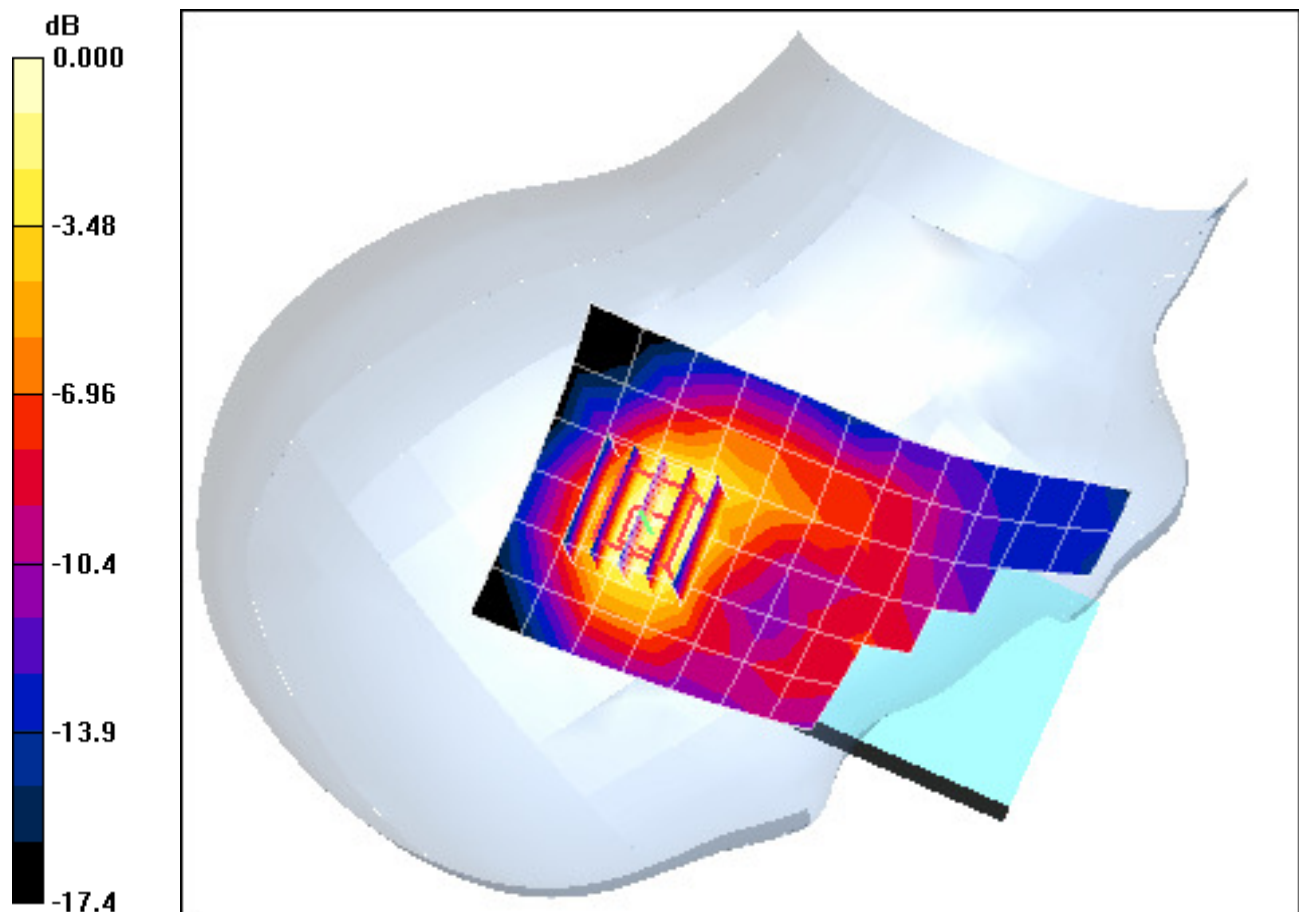

0 dB = 0.143mW/g

# PCTEST ENGINEERING LABORATORY, INC.

**DUT: A3LSGHT839; Type: 850/1900 GSM/GPRS/EDGE and 1700 WCDMA/HSPA Phone with Bluetooth and WLAN; Serial: FI-035-A**

Communication System: GSM1900; Frequency: 1880 MHz; Duty Cycle: 1:8.3

Medium: 1900 Head Medium parameters used:

$f = 1880 \text{ MHz}$ ;  $\sigma = 1.45 \text{ mho/m}$ ;  $\epsilon_r = 40.3$ ;  $\rho = 1000 \text{ kg/m}^3$

Phantom section: Left Section

Test Date: 03-02-2011; Ambient Temp: 24.2 °C; Tissue Temp: 22.5 °C

Probe: ES3DV2 - SN3022; ConvF(4.83, 4.83, 4.83); Calibrated: 9/21/2010

Sensor-Surface: 4mm (Mechanical Surface Detection)

Electronics: DAE4 Sn704; Calibrated: 3/22/2010

Phantom: SAM Main; Type: SAM 4.0; Serial: TP-1406

Measurement SW: DASY4, V4.7 Build 80; Postprocessing SW: SEMCAD, V1.8 Build 186

**Mode: GSM 1900, Left Head, Touch, Mid.ch**

**Area Scan (7x14x1):** Measurement grid: dx=15mm, dy=15mm

**Zoom Scan (5x5x7)/Cube 0:** Measurement grid: dx=8mm, dy=8mm, dz=5mm

Reference Value = 11.7 V/m

Peak SAR (extrapolated) = 0.259 W/kg

**SAR(1 g) = 0.176 mW/g; SAR(10 g) = 0.105 mW/g**

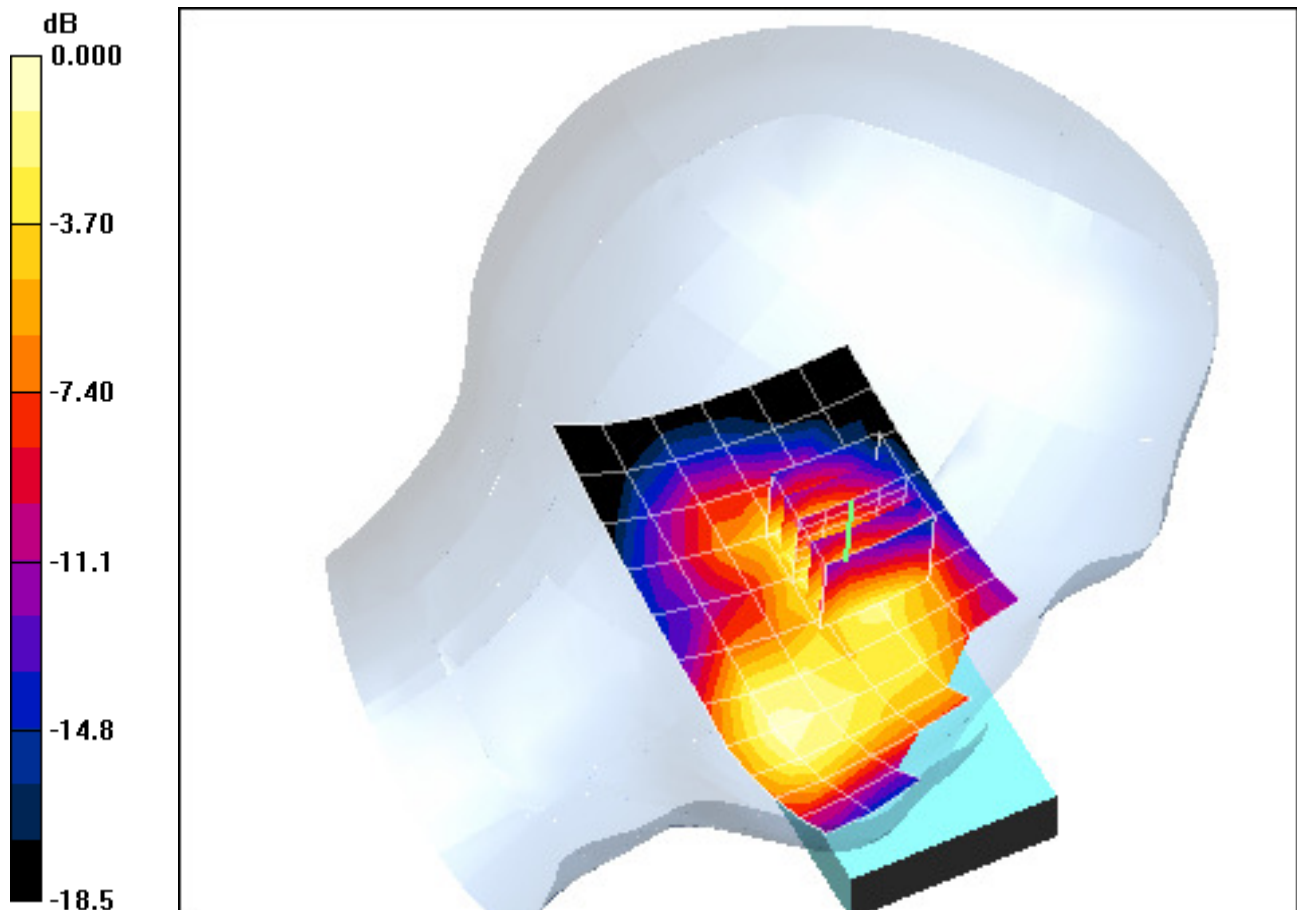

0 dB = 0.195mW/g

# PCTEST ENGINEERING LABORATORY, INC.

**DUT: A3LSGHT839; Type: 850/1900 GSM/GPRS/EDGE and 1700 WCDMA/HSPA Phone with Bluetooth and WLAN; Serial: FI-035-A**

Communication System: GSM1900; Frequency: 1880 MHz; Duty Cycle: 1:8.3

Medium: 1900 Head Medium parameters used:

$f = 1880 \text{ MHz}$ ;  $\sigma = 1.45 \text{ mho/m}$ ;  $\epsilon_r = 40.3$ ;  $\rho = 1000 \text{ kg/m}^3$

Phantom section: Left Section

Test Date: 03-02-2011; Ambient Temp: 24.2 °C; Tissue Temp: 22.5 °C

Probe: ES3DV2 - SN3022; ConvF(4.83, 4.83, 4.83); Calibrated: 9/21/2010

Sensor-Surface: 4mm (Mechanical Surface Detection)

Electronics: DAE4 Sn704; Calibrated: 3/22/2010

Phantom: SAM Main; Type: SAM 4.0; Serial: TP-1406

Measurement SW: DASY4, V4.7 Build 80; Postprocessing SW: SEMCAD, V1.8 Build 186

**Mode: GSM 1900, Left Head, Touch, Mid.ch**

**Area Scan (7x14x1):** Measurement grid: dx=15mm, dy=15mm

**Zoom Scan (5x5x7)/Cube 0:** Measurement grid: dx=8mm, dy=8mm, dz=5mm

Reference Value = 11.7 V/m

Peak SAR (extrapolated) = 0.259 W/kg

**SAR(1 g) = 0.176 mW/g; SAR(10 g) = 0.105 mW/g**

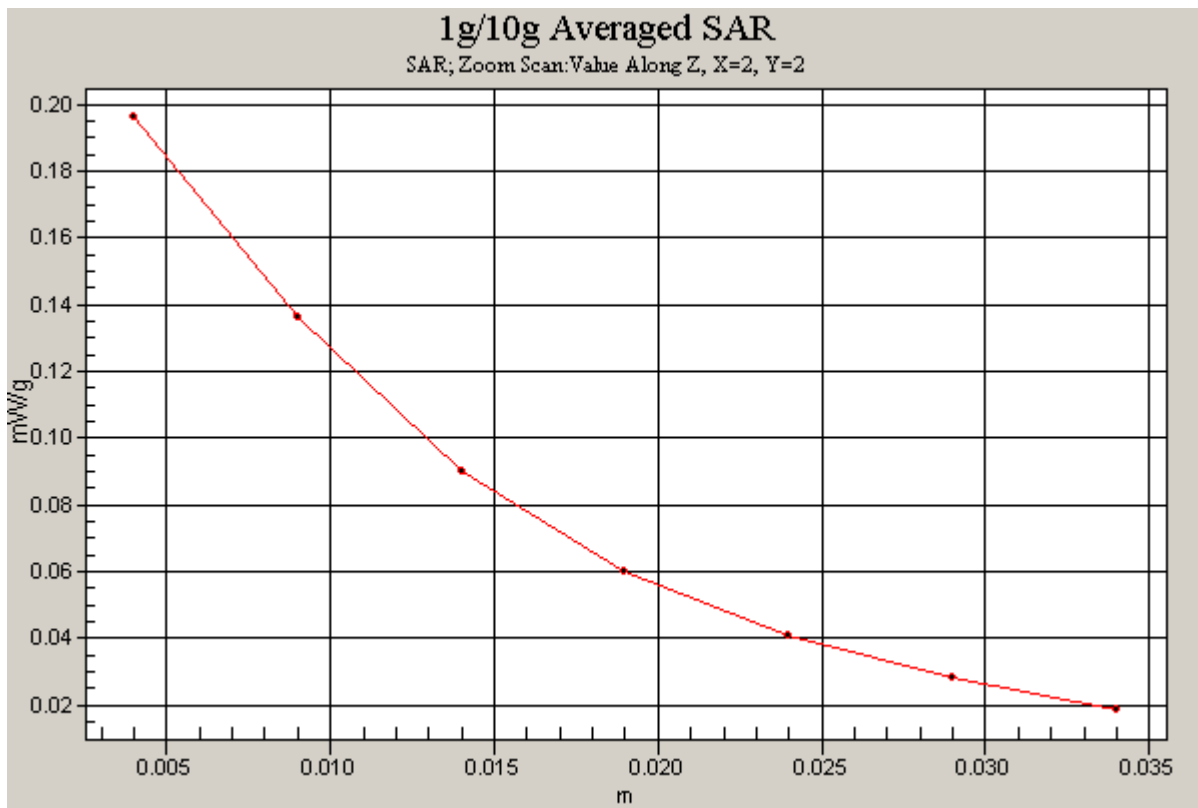

# PCTEST ENGINEERING LABORATORY, INC.

**DUT: A3LSGHT839; Type: 850/1900 GSM/GPRS/EDGE and 1700 WCDMA/HSPA Phone with Bluetooth and WLAN; Serial: FI-035-A**

Communication System: GSM1900; Frequency: 1880 MHz; Duty Cycle: 1:8.3

Medium: 1900 Head Medium parameters used:

$f = 1880 \text{ MHz}$ ;  $\sigma = 1.45 \text{ mho/m}$ ;  $\epsilon_r = 40.3$ ;  $\rho = 1000 \text{ kg/m}^3$

Phantom section: Left Section

Test Date: 03-02-2011; Ambient Temp: 24.2 °C; Tissue Temp: 22.5 °C

Probe: ES3DV2 - SN3022; ConvF(4.83, 4.83, 4.83); Calibrated: 9/21/2010

Sensor-Surface: 4mm (Mechanical Surface Detection)

Electronics: DAE4 Sn704; Calibrated: 3/22/2010

Phantom: SAM Main; Type: SAM 4.0; Serial: TP-1406

Measurement SW: DASY4, V4.7 Build 80; Postprocessing SW: SEMCAD, V1.8 Build 186

**Mode: GSM 1900, Left Head, Tilt, Mid.ch**

**Area Scan (7x14x1):** Measurement grid: dx=15mm, dy=15mm

**Zoom Scan (5x5x7)/Cube 0:** Measurement grid: dx=8mm, dy=8mm, dz=5mm

Reference Value = 8.93 V/m

Peak SAR (extrapolated) = 0.165 W/kg

**SAR(1 g) = 0.114 mW/g; SAR(10 g) = 0.070 mW/g**

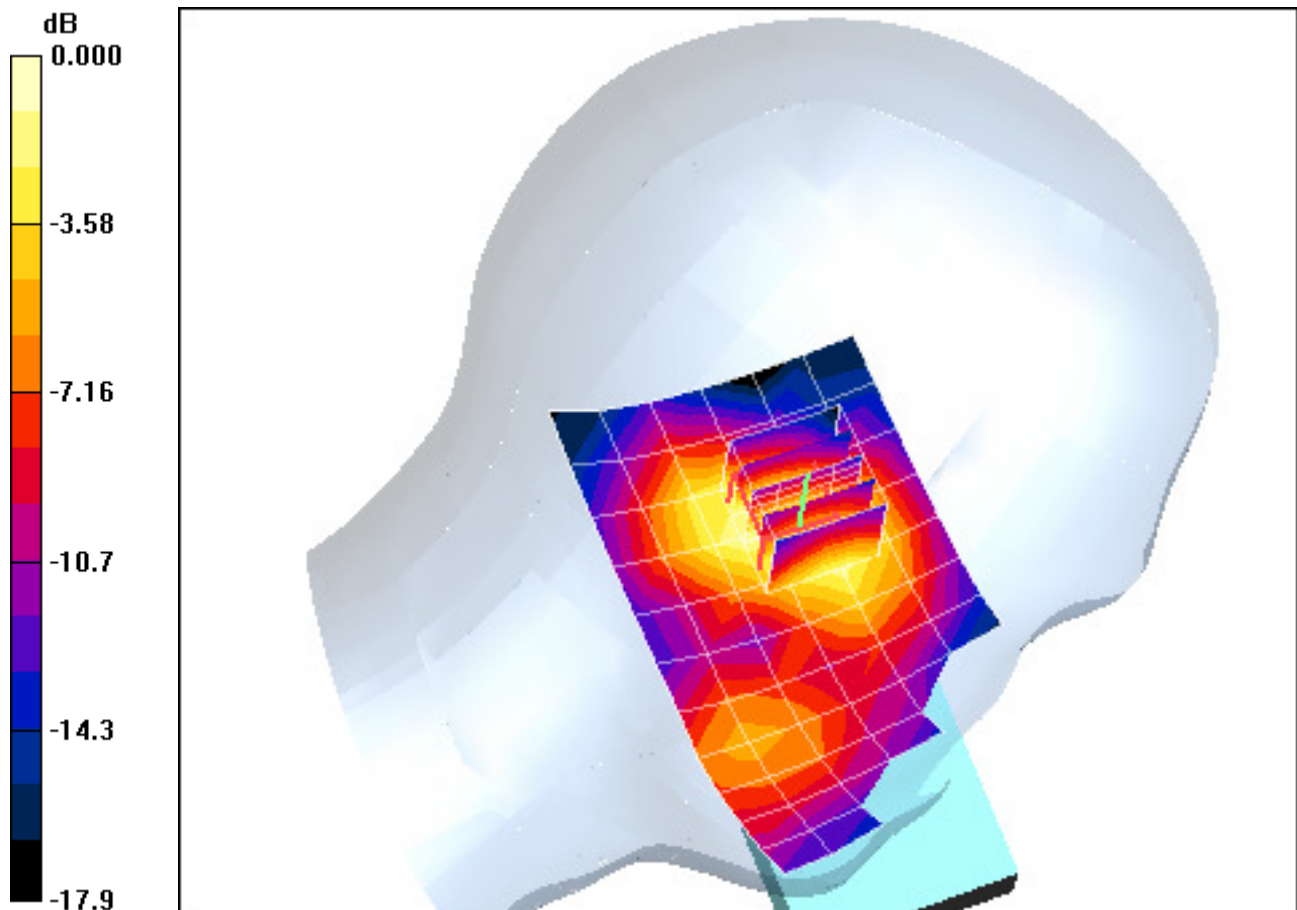

0 dB = 0.119mW/g

# PCTEST ENGINEERING LABORATORY, INC.

**DUT: A3LSGHT839; Type: 850/1900 GSM/GPRS/EDGE and 1700 WCDMA/HSPA Phone with Bluetooth and WLAN; Serial: FI-035-A**

Communication System: WCDMA1700; Frequency: 1730.4 MHz; Duty Cycle: 1:1  
Medium: 1750 Head Medium parameters used (interpolated):  
 $f = 1730.4 \text{ MHz}$ ;  $\sigma = 1.37 \text{ mho/m}$ ;  $\epsilon_r = 40.7$ ;  $\rho = 1000 \text{ kg/m}^3$   
Phantom section: Right Section

Test Date: 03-04-2011; Ambient Temp: 22.4 °C; Tissue Temp: 21.2 °C

Probe: EX3DV4 - SN3550; ConvF(7.33, 7.33, 7.33); Calibrated: 2/14/2011  
Sensor-Surface: 4mm (Mechanical Surface Detection)  
Electronics: DAE4 Sn859; Calibrated: 7/8/2010

Phantom: SAM Main; Type: SAM 4.0; Serial: TP-1114

Measurement SW: DASY4, V4.7 Build 80; Postprocessing SW: SEMCAD, V1.8 Build 186

**Mode: WCDMA 1700, Right Head, Touch, Mid.ch**

**Area Scan (7x12x1):** Measurement grid: dx=15mm, dy=15mm

**Zoom Scan (5x5x7)/Cube 0:** Measurement grid: dx=8mm, dy=8mm, dz=5mm

Reference Value = 13.2 V/m

Peak SAR (extrapolated) = 0.409 W/kg

**SAR(1 g) = 0.254 mW/g; SAR(10 g) = 0.154 mW/g**

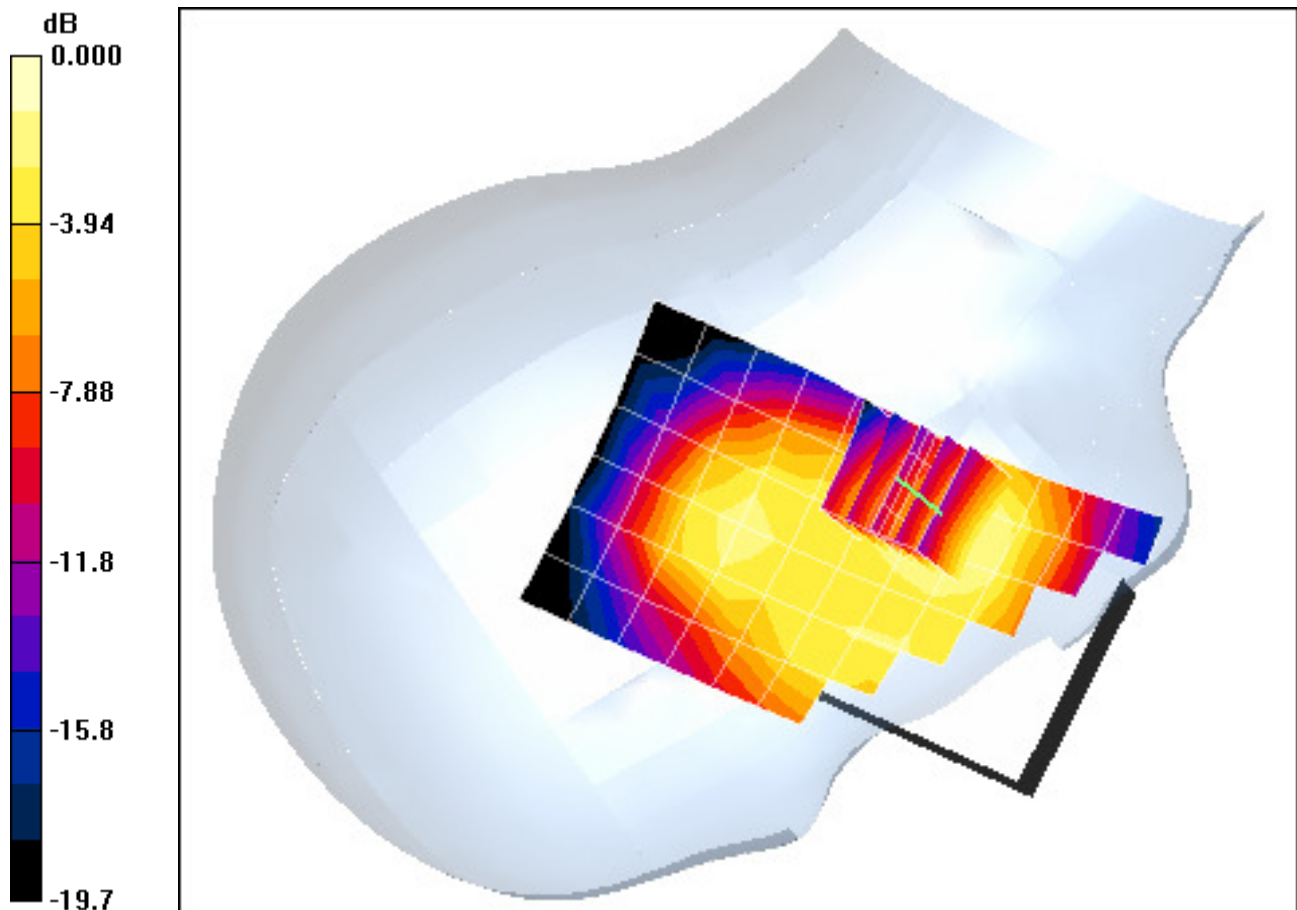

0 dB = 0.281mW/g

# PCTEST ENGINEERING LABORATORY, INC.

**DUT: A3LSGHT839; Type: 850/1900 GSM/GPRS/EDGE and 1700 WCDMA/HSPA Phone with Bluetooth and WLAN; Serial: FI-035-A**

Communication System: WCDMA1700; Frequency: 1730.4 MHz; Duty Cycle: 1:1  
Medium: 1750 Head Medium parameters used (interpolated):  
 $f = 1730.4 \text{ MHz}$ ;  $\sigma = 1.37 \text{ mho/m}$ ;  $\epsilon_r = 40.7$ ;  $\rho = 1000 \text{ kg/m}^3$   
Phantom section: Right Section

Test Date: 03-04-2011; Ambient Temp: 22.4 °C; Tissue Temp: 21.2 °C

Probe: EX3DV4 - SN3550; ConvF(7.33, 7.33, 7.33); Calibrated: 2/14/2011  
Sensor-Surface: 4mm (Mechanical Surface Detection)  
Electronics: DAE4 Sn859; Calibrated: 7/8/2010

Phantom: SAM Main; Type: SAM 4.0; Serial: TP-1114

Measurement SW: DASY4, V4.7 Build 80; Postprocessing SW: SEMCAD, V1.8 Build 186

**Mode: WCDMA 1700, Right Head, Tilt, Mid.ch**

**Area Scan (7x12x1):** Measurement grid: dx=15mm, dy=15mm

**Zoom Scan (5x5x7)/Cube 0:** Measurement grid: dx=8mm, dy=8mm, dz=5mm

Reference Value = 13.2 V/m

Peak SAR (extrapolated) = 0.410 W/kg

**SAR(1 g) = 0.256 mW/g; SAR(10 g) = 0.153 mW/g**

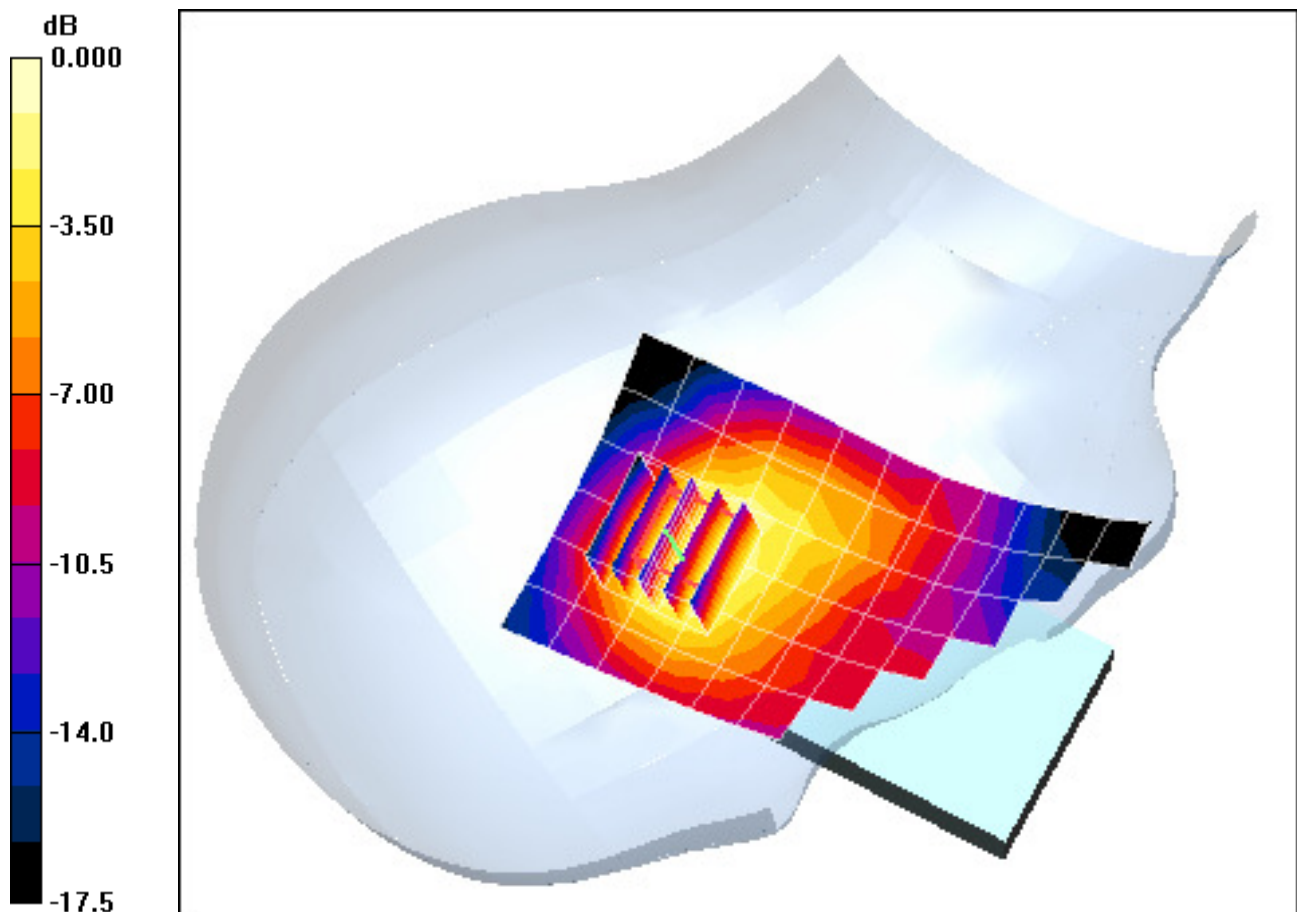

0 dB = 0.254mW/g

# PCTEST ENGINEERING LABORATORY, INC.

**DUT: A3LSGHT839; Type: 850/1900 GSM/GPRS/EDGE and 1700 WCDMA/HSPA Phone with Bluetooth and WLAN; Serial: FI-035-A**

Communication System: WCDMA1700; Frequency: 1730.4 MHz; Duty Cycle: 1:1  
Medium: 1750 Head Medium parameters used (interpolated):  
 $f = 1730.4 \text{ MHz}$ ;  $\sigma = 1.37 \text{ mho/m}$ ;  $\epsilon_r = 40.7$ ;  $\rho = 1000 \text{ kg/m}^3$   
Phantom section: Left Section

Test Date: 03-04-2011; Ambient Temp: 22.4 °C; Tissue Temp: 21.2 °C

Probe: EX3DV4 - SN3550; ConvF(7.33, 7.33, 7.33); Calibrated: 2/14/2011  
Sensor-Surface: 4mm (Mechanical Surface Detection)  
Electronics: DAE4 Sn859; Calibrated: 7/8/2010  
Phantom: SAM Main; Type: SAM 4.0; Serial: TP-1114  
Measurement SW: DASY4, V4.7 Build 80; Postprocessing SW: SEMCAD, V1.8 Build 186

**Mode: WCDMA 1700, Left Head, Touch, Mid.ch**

**Area Scan (7x12x1):** Measurement grid: dx=15mm, dy=15mm  
**Zoom Scan (5x5x7)/Cube 0:** Measurement grid: dx=8mm, dy=8mm, dz=5mm  
Reference Value = 15.2 V/m  
Peak SAR (extrapolated) = 0.526 W/kg  
**SAR(1 g) = 0.335 mW/g; SAR(10 g) = 0.205 mW/g**

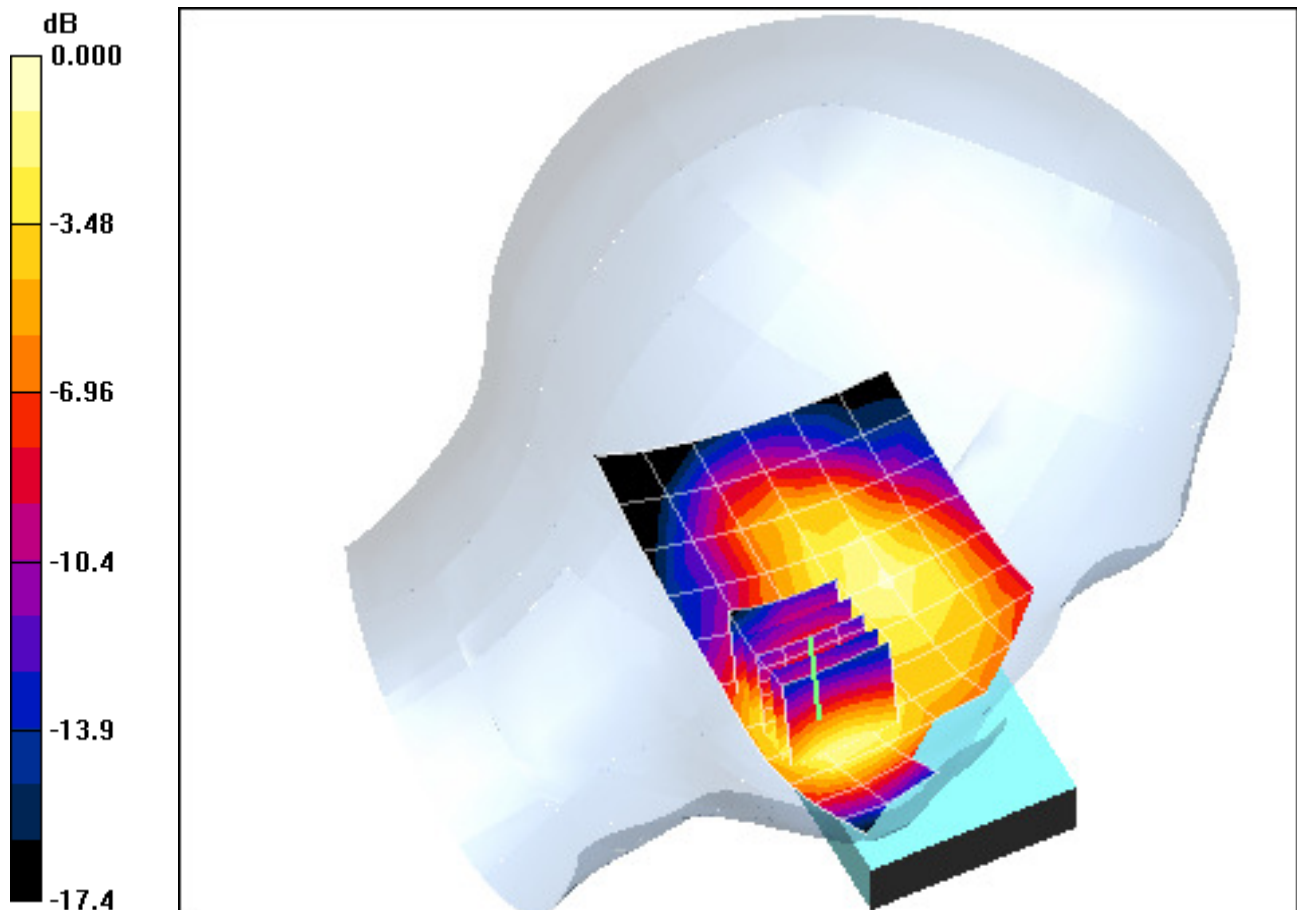

0 dB = 0.366mW/g

# PCTEST ENGINEERING LABORATORY, INC.

**DUT: A3LSGHT839; Type: 850/1900 GSM/GPRS/EDGE and 1700 WCDMA/HSPA Phone with Bluetooth and WLAN; Serial: FI-035-A**

Communication System: WCDMA1700; Frequency: 1730.4 MHz; Duty Cycle: 1:1  
Medium: 1750 Head Medium parameters used (interpolated):  
 $f = 1730.4 \text{ MHz}$ ;  $\sigma = 1.37 \text{ mho/m}$ ;  $\epsilon_r = 40.7$ ;  $\rho = 1000 \text{ kg/m}^3$   
Phantom section: Left Section

Test Date: 03-04-2011; Ambient Temp: 22.4 °C; Tissue Temp: 21.2 °C

Probe: EX3DV4 - SN3550; ConvF(7.33, 7.33, 7.33); Calibrated: 2/14/2011  
Sensor-Surface: 4mm (Mechanical Surface Detection)  
Electronics: DAE4 Sn859; Calibrated: 7/8/2010  
Phantom: SAM Main; Type: SAM 4.0; Serial: TP-1114  
Measurement SW: DASY4, V4.7 Build 80; Postprocessing SW: SEMCAD, V1.8 Build 186

**Mode: WCDMA 1700, Left Head, Touch, Mid.ch**

**Area Scan (7x12x1):** Measurement grid: dx=15mm, dy=15mm  
**Zoom Scan (5x5x7)/Cube 0:** Measurement grid: dx=8mm, dy=8mm, dz=5mm  
Reference Value = 15.2 V/m  
Peak SAR (extrapolated) = 0.526 W/kg  
**SAR(1 g) = 0.335 mW/g; SAR(10 g) = 0.205 mW/g**

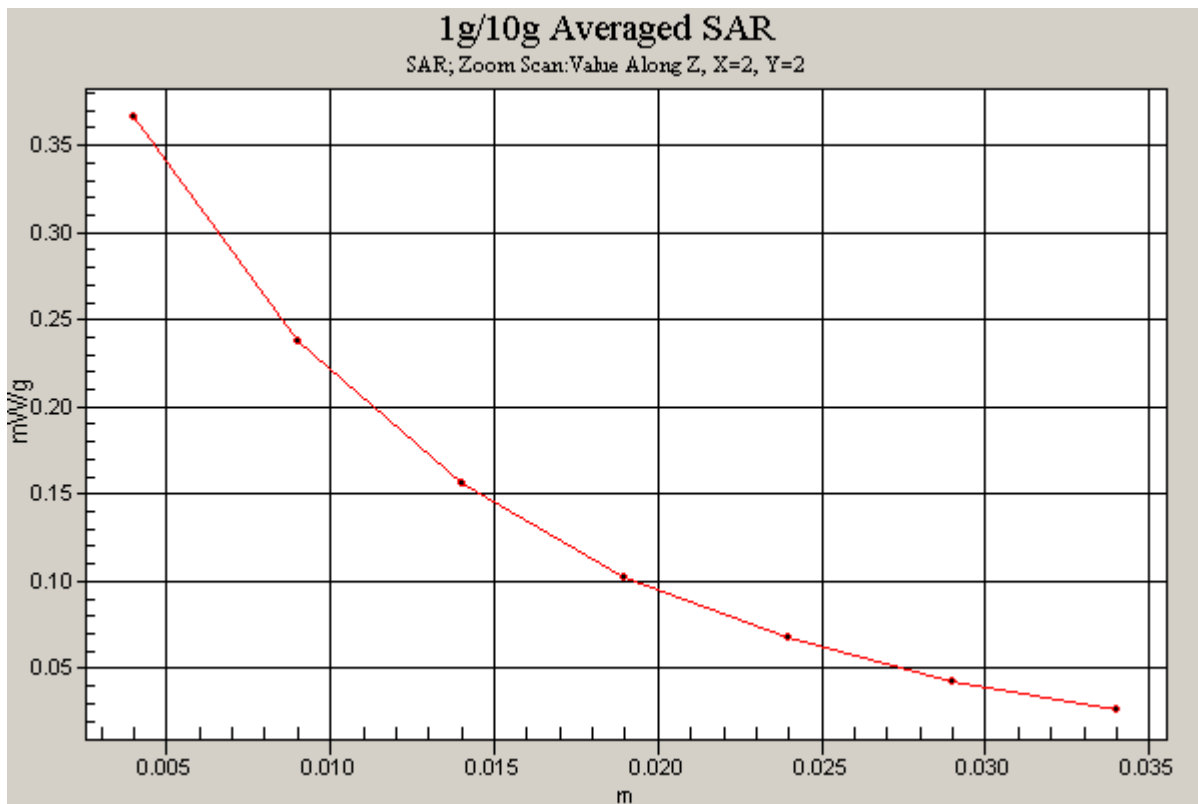

# PCTEST ENGINEERING LABORATORY, INC.

**DUT: A3LSGHT839; Type: 850/1900 GSM/GPRS/EDGE and 1700 WCDMA/HSPA Phone with Bluetooth and WLAN; Serial: FI-035-A**

Communication System: WCDMA1700; Frequency: 1730.4 MHz; Duty Cycle: 1:1  
Medium: 1750 Head Medium parameters used (interpolated):  
 $f = 1730.4 \text{ MHz}$ ;  $\sigma = 1.37 \text{ mho/m}$ ;  $\epsilon_r = 40.7$ ;  $\rho = 1000 \text{ kg/m}^3$   
Phantom section: Left Section

Test Date: 03-04-2011; Ambient Temp: 22.4 °C; Tissue Temp: 21.2 °C

Probe: EX3DV4 - SN3550; ConvF(7.33, 7.33, 7.33); Calibrated: 2/14/2011  
Sensor-Surface: 4mm (Mechanical Surface Detection)  
Electronics: DAE4 Sn859; Calibrated: 7/8/2010  
Phantom: SAM Main; Type: SAM 4.0; Serial: TP-1114

Measurement SW: DASY4, V4.7 Build 80; Postprocessing SW: SEMCAD, V1.8 Build 186

**Mode: WCDMA 1700, Left Head, Tilt, Mid.ch**

**Area Scan (7x12x1):** Measurement grid: dx=15mm, dy=15mm

**Zoom Scan (5x5x7)/Cube 0:** Measurement grid: dx=8mm, dy=8mm, dz=5mm

Reference Value = 13.5 V/m

Peak SAR (extrapolated) = 0.358 W/kg

**SAR(1 g) = 0.232 mW/g; SAR(10 g) = 0.143 mW/g**

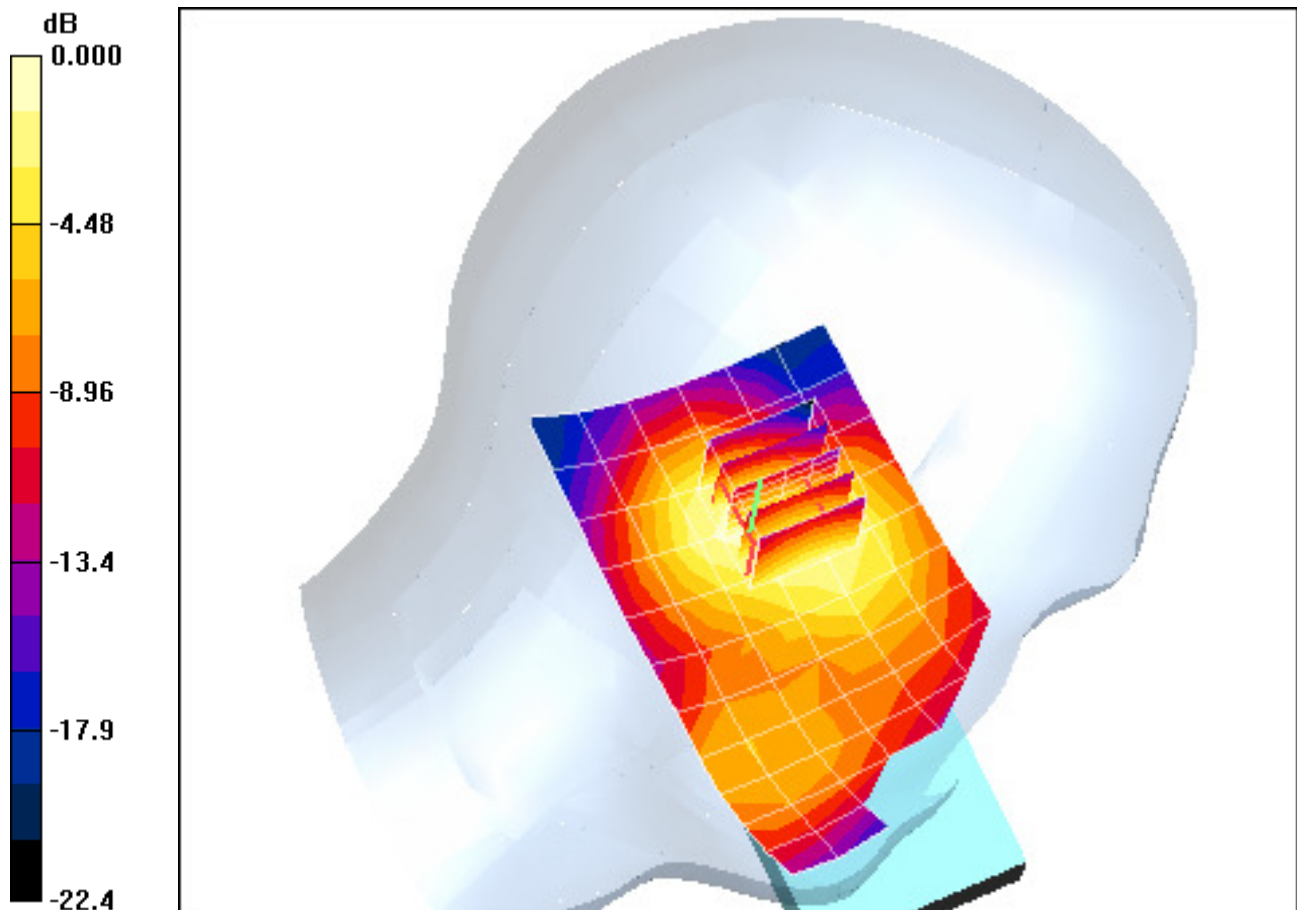

0 dB = 0.248mW/g

# PCTEST ENGINEERING LABORATORY, INC.

**DUT: A3LSGHT839; Type: 850/1900 GSM/GPRS/EDGE and 1700 WCDMA/HSPA Phone with Bluetooth and WLAN; Serial: FI-035-A**

Communication System: IEEE 802.11b; Frequency: 2462 MHz; Duty Cycle: 1:1  
Medium: 2450 Head Medium parameters used (interpolated):

$$f = 2462 \text{ MHz}; \sigma = 1.84 \text{ mho/m}; \epsilon_r = 38; \rho = 1000 \text{ kg/m}^3$$

Phantom section: Right Section

Test Date: 03-02-2011; Ambient Temp: 23.8 °C; Tissue Temp: 21.9 °C

Probe: EX3DV4 - SN3550; ConvF(6.29, 6.29, 6.29); Calibrated: 2/14/2011

Sensor-Surface: 3mm (Mechanical Surface Detection)

Electronics: DAE4 Sn859; Calibrated: 7/8/2010

Phantom: SAM Main; Type: SAM 4.0; Serial: TP-1114

Measurement SW: DASY4, V4.7 Build 80; Postprocessing SW: SEMCAD, V1.8 Build 186

**Mode: IEEE 802.11b, Right Head, Touch, Ch 11, 1 Mbps**

**Area Scan (7x11x1):** Measurement grid: dx=15mm, dy=15mm

**Zoom Scan (5x5x7)/Cube 0:** Measurement grid: dx=8mm, dy=8mm, dz=5mm

Reference Value = 14.1 V/m

Peak SAR (extrapolated) = 0.659 W/kg

**SAR(1 g) = 0.323 mW/g; SAR(10 g) = 0.153 mW/g**

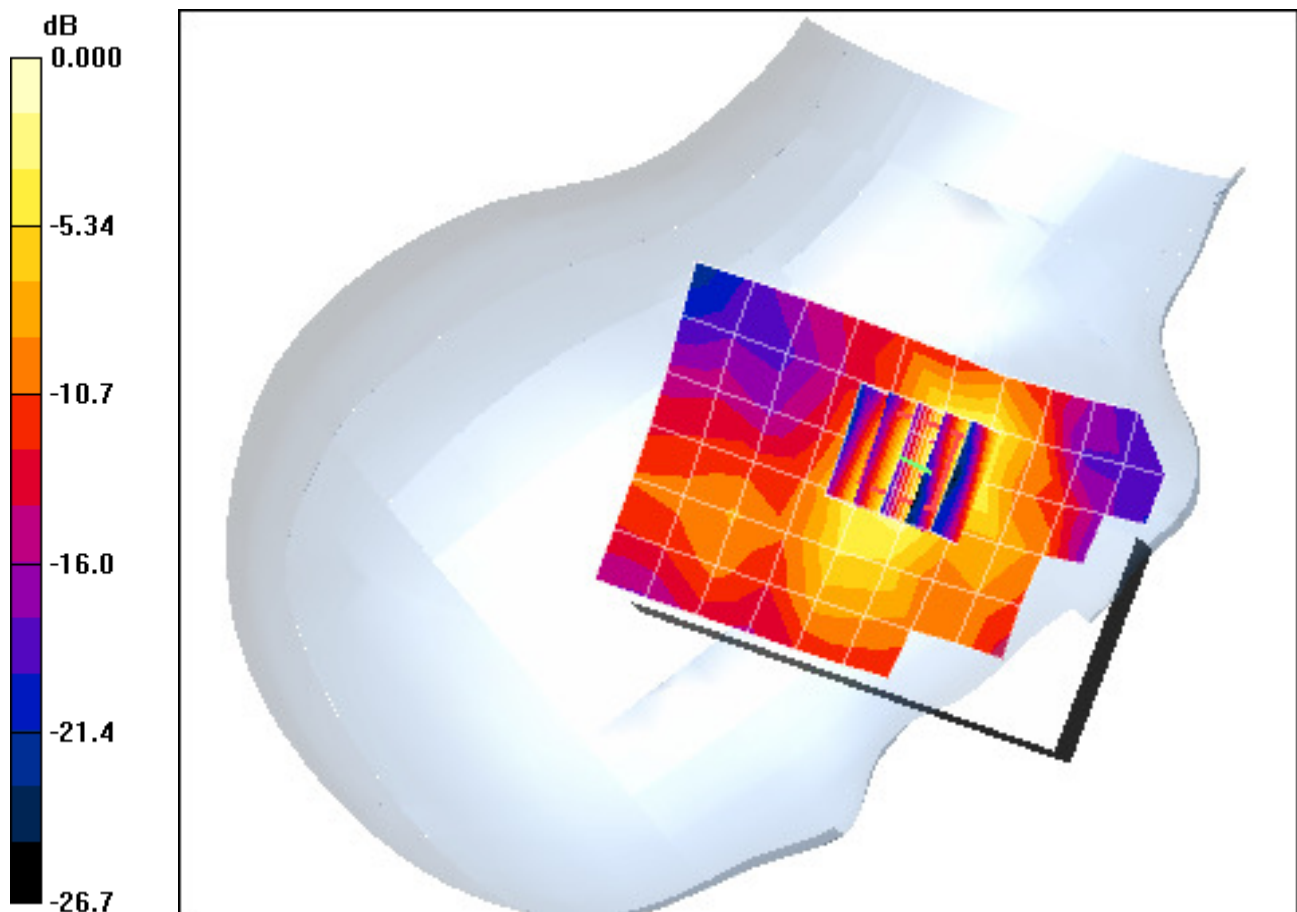

0 dB = 0.420mW/g

# PCTEST ENGINEERING LABORATORY, INC.

**DUT: A3LSGHT839; Type: 850/1900 GSM/GPRS/EDGE and 1700 WCDMA/HSPA Phone with Bluetooth and WLAN; Serial: FI-035-A**

Communication System: IEEE 802.11b; Frequency: 2462 MHz; Duty Cycle: 1:1  
Medium: 2450 Head Medium parameters used (interpolated):

$$f = 2462 \text{ MHz}; \sigma = 1.84 \text{ mho/m}; \epsilon_r = 38; \rho = 1000 \text{ kg/m}^3$$

Phantom section: Right Section

Test Date: 03-02-2011; Ambient Temp: 23.8 °C; Tissue Temp: 21.9 °C

Probe: EX3DV4 - SN3550; ConvF(6.29, 6.29, 6.29); Calibrated: 2/14/2011

Sensor-Surface: 3mm (Mechanical Surface Detection)

Electronics: DAE4 Sn859; Calibrated: 7/8/2010

Phantom: SAM Main; Type: SAM 4.0; Serial: TP-1114

Measurement SW: DASY4, V4.7 Build 80; Postprocessing SW: SEMCAD, V1.8 Build 186

**Mode: IEEE 802.11b, Right Head, Touch, Ch 11, 1 Mbps**

**Area Scan (7x11x1):** Measurement grid: dx=15mm, dy=15mm

**Zoom Scan (5x5x7)/Cube 0:** Measurement grid: dx=8mm, dy=8mm, dz=5mm

Reference Value = 14.1 V/m

Peak SAR (extrapolated) = 0.659 W/kg

**SAR(1 g) = 0.323 mW/g; SAR(10 g) = 0.153 mW/g**

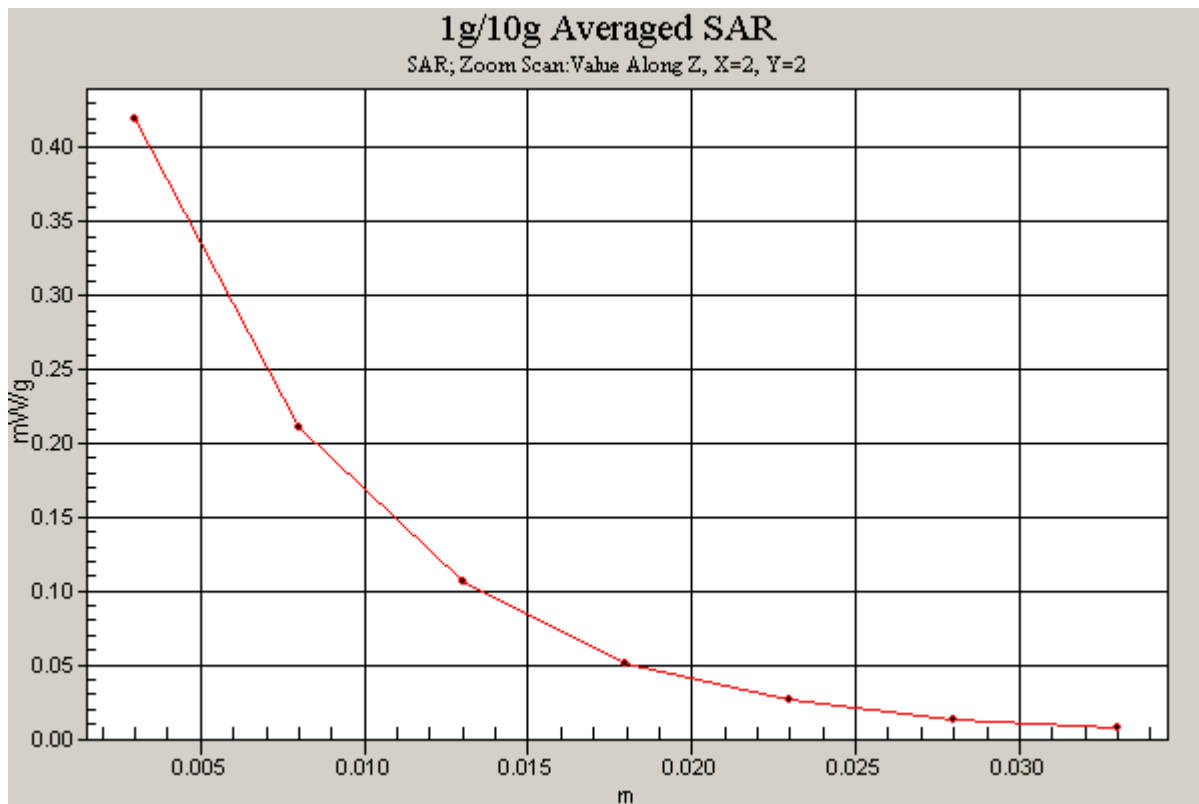

# PCTEST ENGINEERING LABORATORY, INC.

**DUT: A3LSGHT839; Type: 850/1900 GSM/GPRS/EDGE and 1700 WCDMA/HSPA Phone with Bluetooth and WLAN; Serial: FI-035-A**

Communication System: IEEE 802.11b; Frequency: 2462 MHz; Duty Cycle: 1:1  
Medium: 2450 Head Medium parameters used (interpolated):

$$f = 2462 \text{ MHz}; \sigma = 1.84 \text{ mho/m}; \epsilon_r = 38; \rho = 1000 \text{ kg/m}^3$$

Phantom section: Right Section

Test Date: 03-02-2011; Ambient Temp: 23.8 °C; Tissue Temp: 21.9 °C

Probe: EX3DV4 - SN3550; ConvF(6.29, 6.29, 6.29); Calibrated: 2/14/2011

Sensor-Surface: 3mm (Mechanical Surface Detection)

Electronics: DAE4 Sn859; Calibrated: 7/8/2010

Phantom: SAM Main; Type: SAM 4.0; Serial: TP-1114

Measurement SW: DASY4, V4.7 Build 80; Postprocessing SW: SEMCAD, V1.8 Build 186

**Mode: IEEE 802.11b, Right Head, Tilt, Ch 11, 1 Mbps**

**Area Scan (7x11x1):** Measurement grid: dx=15mm, dy=15mm

**Zoom Scan (5x5x7)/Cube 0:** Measurement grid: dx=8mm, dy=8mm, dz=5mm

Reference Value = 7.50 V/m

Peak SAR (extrapolated) = 0.174 W/kg

**SAR(1 g) = 0.093 mW/g; SAR(10 g) = 0.0497 mW/g**

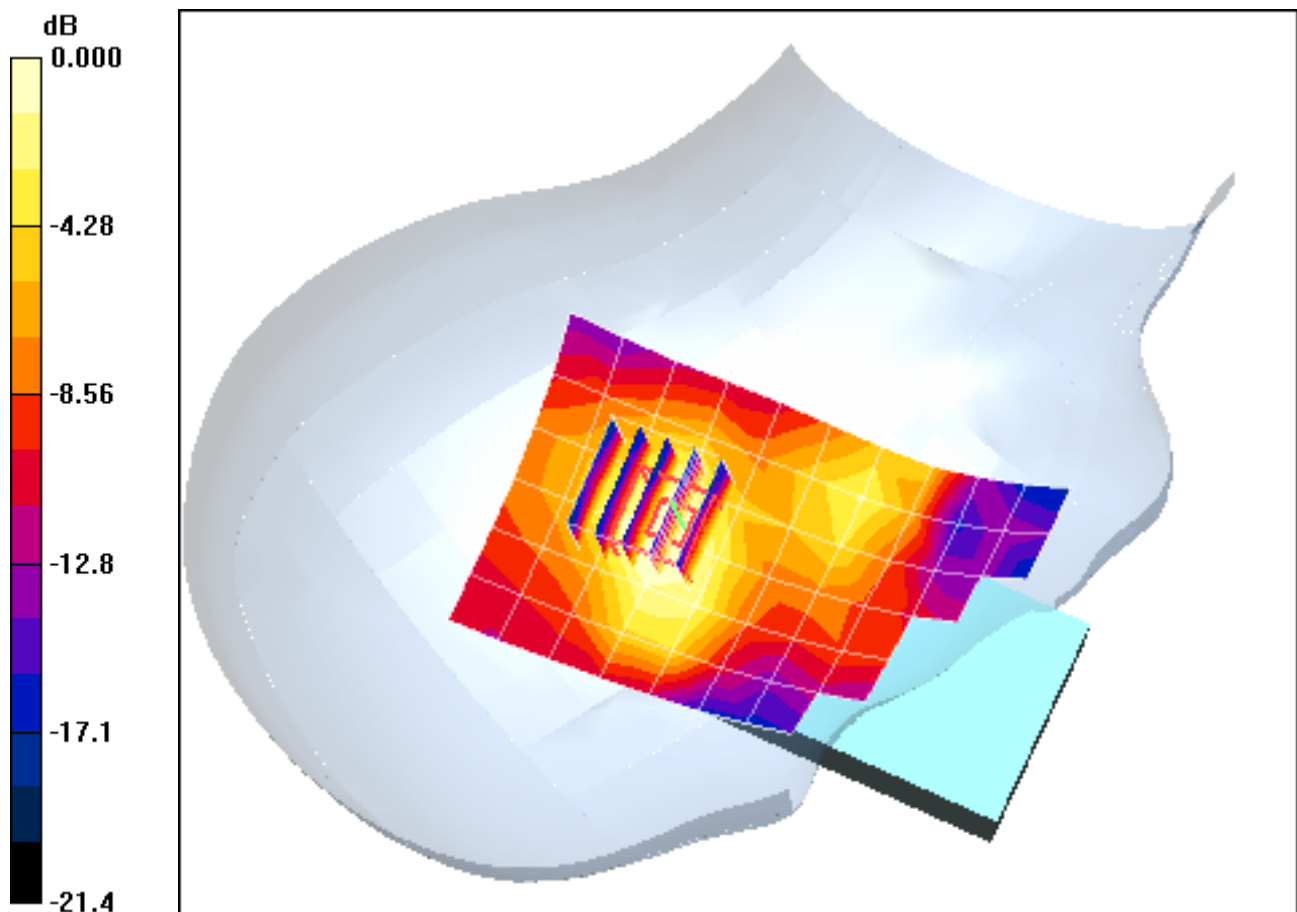

0 dB = 0.114mW/g

# PCTEST ENGINEERING LABORATORY, INC.

**DUT: A3LSGHT839; Type: 850/1900 GSM/GPRS/EDGE and 1700 WCDMA/HSPA Phone with Bluetooth and WLAN; Serial: FI-035-A**

Communication System: IEEE 802.11b; Frequency: 2462 MHz; Duty Cycle: 1:1  
Medium: 2450 Head Medium parameters used (interpolated):  
 $f = 2462 \text{ MHz}$ ;  $\sigma = 1.84 \text{ mho/m}$ ;  $\epsilon_r = 38$ ;  $\rho = 1000 \text{ kg/m}^3$   
Phantom section: Left Section

Test Date: 03-02-2011; Ambient Temp: 23.8 °C; Tissue Temp: 21.9 °C

Probe: EX3DV4 - SN3550; ConvF(6.29, 6.29, 6.29); Calibrated: 2/14/2011  
Sensor-Surface: 3mm (Mechanical Surface Detection)  
Electronics: DAE4 Sn859; Calibrated: 7/8/2010

Phantom: SAM Main; Type: SAM 4.0; Serial: TP-1114  
Measurement SW: DASY4, V4.7 Build 80; Postprocessing SW: SEMCAD, V1.8 Build 186

**Mode: IEEE 802.11b, Left Head, Touch, Ch 11, 1 Mbps**

**Area Scan (7x11x1):** Measurement grid: dx=15mm, dy=15mm

**Zoom Scan (5x5x7)/Cube 0:** Measurement grid: dx=8mm, dy=8mm, dz=5mm

Reference Value = 11.1 V/m

Peak SAR (extrapolated) = 0.389 W/kg

**SAR(1 g) = 0.210 mW/g; SAR(10 g) = 0.112 mW/g**

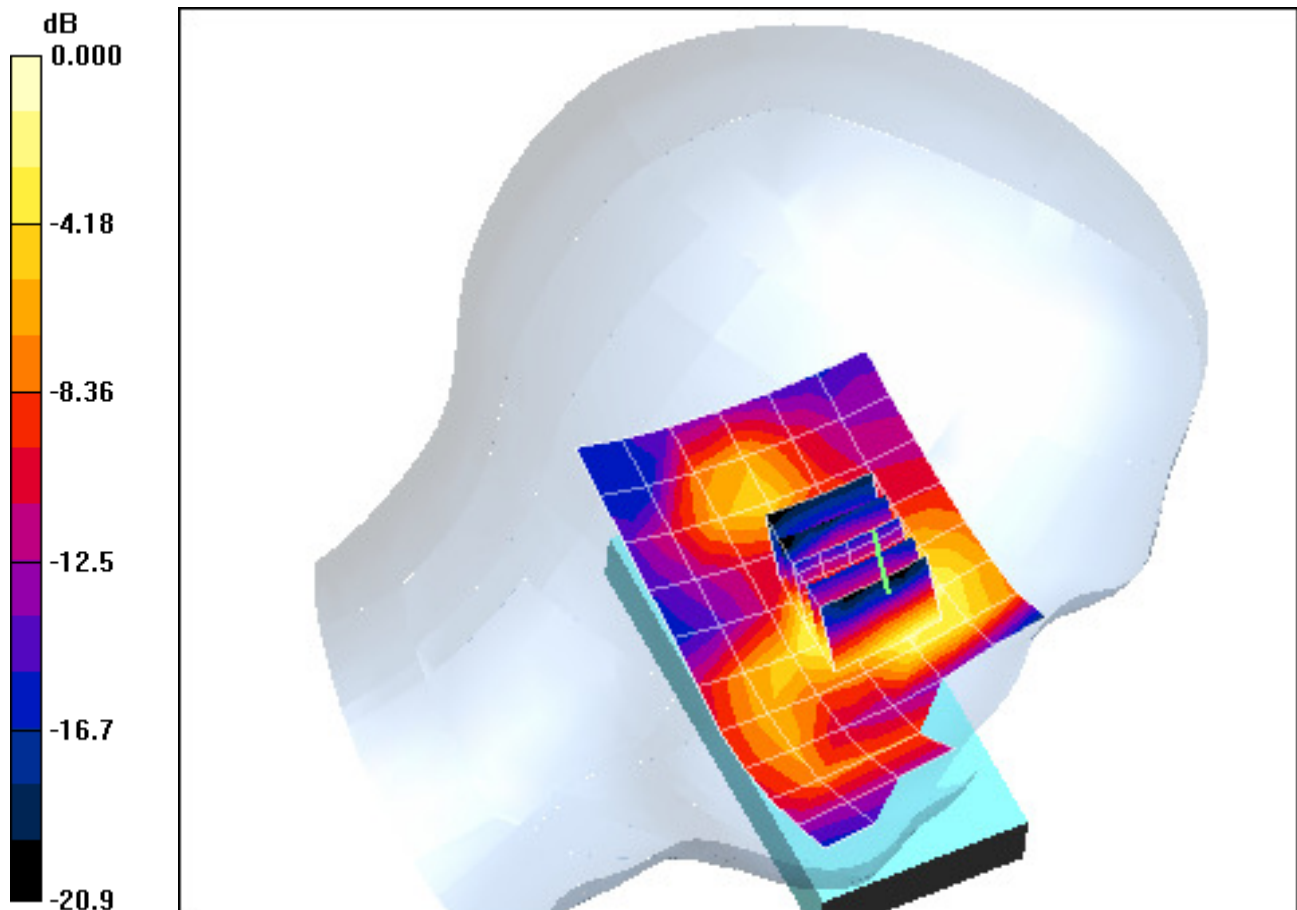

0 dB = 0.253mW/g

# PCTEST ENGINEERING LABORATORY, INC.

**DUT: A3LSGHT839; Type: 850/1900 GSM/GPRS/EDGE and 1700 WCDMA/HSPA Phone with Bluetooth and WLAN; Serial: FI-035-A**

Communication System: IEEE 802.11b; Frequency: 2462 MHz; Duty Cycle: 1:1  
Medium: 2450 Head Medium parameters used (interpolated):

$$f = 2462 \text{ MHz}; \sigma = 1.84 \text{ mho/m}; \epsilon_r = 38; \rho = 1000 \text{ kg/m}^3$$

Phantom section: Left Section

Test Date: 03-02-2011; Ambient Temp: 23.8 °C; Tissue Temp: 21.9 °C

Probe: EX3DV4 - SN3550; ConvF(6.29, 6.29, 6.29); Calibrated: 2/14/2011

Sensor-Surface: 3mm (Mechanical Surface Detection)

Electronics: DAE4 Sn859; Calibrated: 7/8/2010

Phantom: SAM Main; Type: SAM 4.0; Serial: TP-1114

Measurement SW: DASY4, V4.7 Build 80; Postprocessing SW: SEMCAD, V1.8 Build 186

**Mode: IEEE 802.11b, Left Head, Tilt, Ch 11, 1 Mbps**

**Area Scan (7x11x1):** Measurement grid: dx=15mm, dy=15mm

**Zoom Scan (5x5x7)/Cube 0:** Measurement grid: dx=8mm, dy=8mm, dz=5mm

Reference Value = 9.19 V/m

Peak SAR (extrapolated) = 0.344 W/kg

**SAR(1 g) = 0.172 mW/g; SAR(10 g) = 0.084 mW/g**

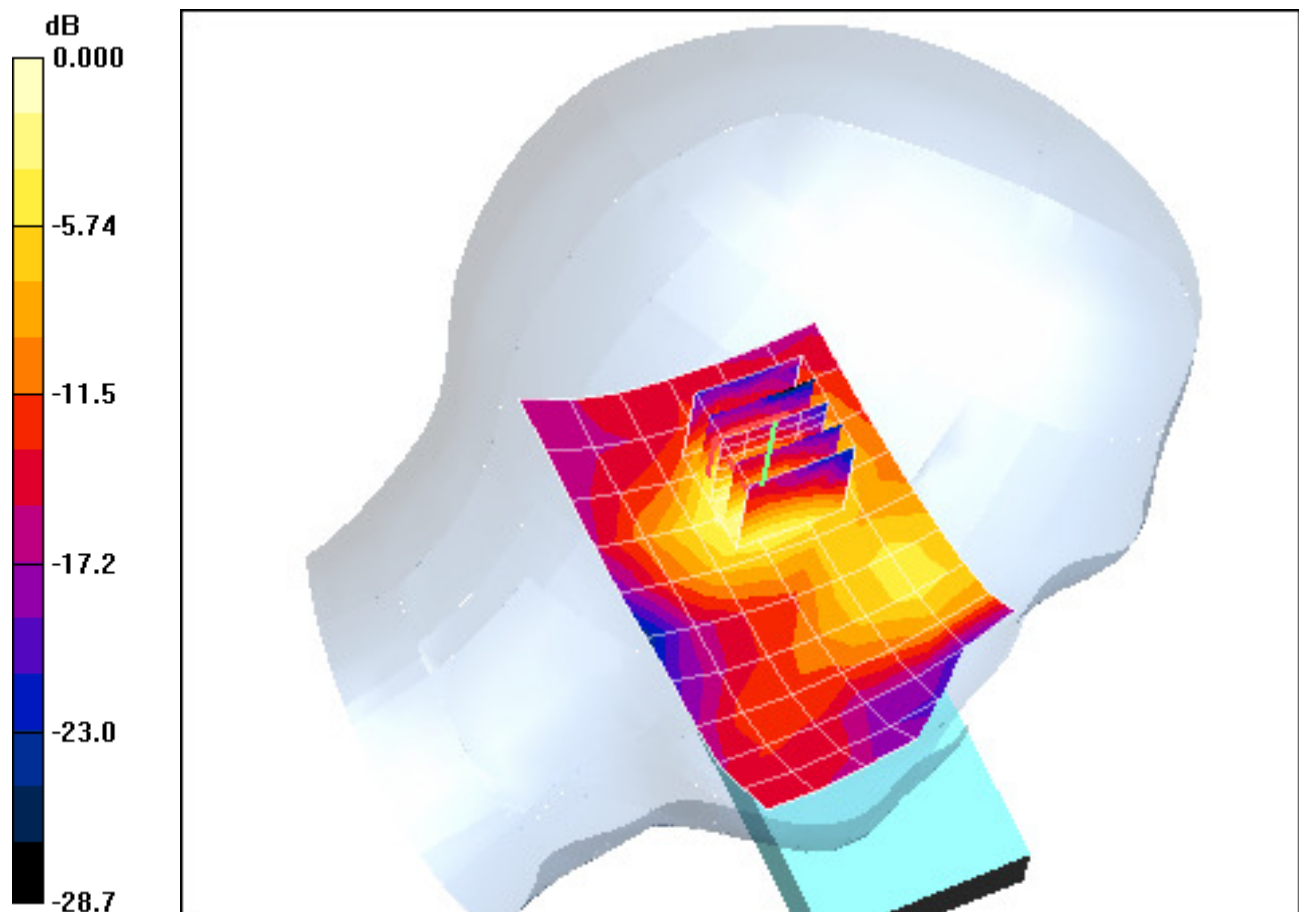

0 dB = 0.209mW/g

# PCTEST ENGINEERING LABORATORY, INC.

**DUT: A3LSGHT839; Type: 850/1900 GSM/GPRS/EDGE and 1700 WCDMA/HSPA Phone with Bluetooth and WLAN; Serial: FI-035-A**

Communication System: GSM850 GPRS; 2 Tx slots; Frequency: 836.6 MHz; Duty Cycle: 1:4.15  
Medium: 835 Body Medium parameters used (interpolated):

$$f = 836.6 \text{ MHz}; \sigma = 0.96 \text{ mho/m}; \epsilon_r = 52.9; \rho = 1000 \text{ kg/m}^3$$

Phantom section: Flat Section; Space: 1.0 cm

Test Date: 02-28-2011; Ambient Temp: 23.7 °C; Tissue Temp: 22.0 °C

Probe: ES3DV2 - SN3022; ConvF(5.89, 5.89, 5.89); Calibrated: 9/21/2010

Sensor-Surface: 4mm (Mechanical Surface Detection)

Electronics: DAE4 Sn704; Calibrated: 3/22/2010

Phantom: SAM Sub; Type: SAM 4.0; Serial: TP-1403

Measurement SW: DASY4, V4.7 Build 80; Postprocessing SW: SEMCAD, V1.8 Build 186

**Mode: GPRS 850, Body SAR, Back side, Mid.ch, 2 Tx Slots**

**Area Scan (7x10x1):** Measurement grid: dx=15mm, dy=15mm

**Zoom Scan (5x5x7)/Cube 0:** Measurement grid: dx=8mm, dy=8mm, dz=5mm

Reference Value = 32.7 V/m

Peak SAR (extrapolated) = 1.30 W/kg

**SAR(1 g) = 0.963 mW/g; SAR(10 g) = 0.691 mW/g**

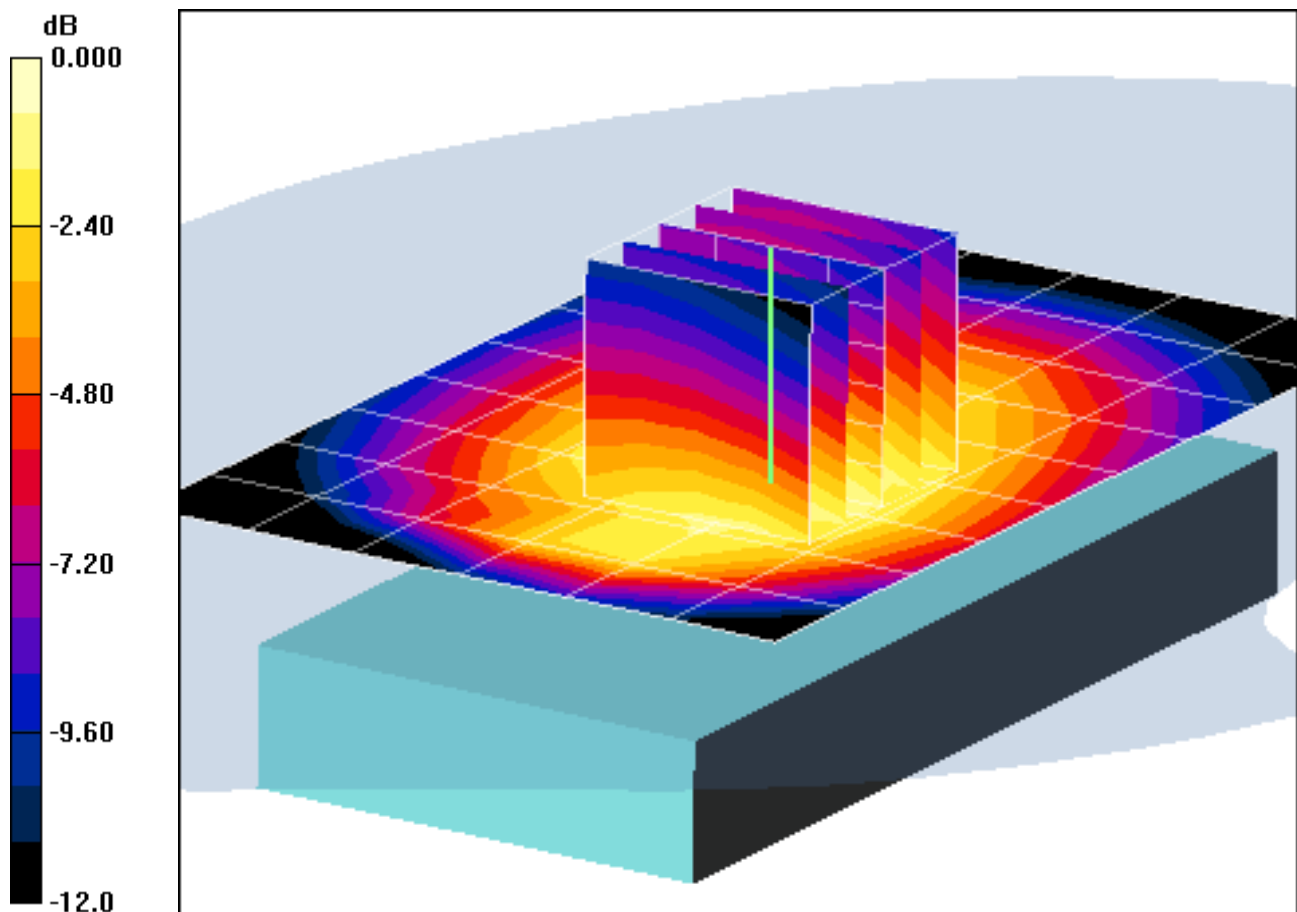

0 dB = 1.02mW/g

# PCTEST ENGINEERING LABORATORY, INC.

**DUT: A3LSGHT839; Type: 850/1900 GSM/GPRS/EDGE and 1700 WCDMA/HSPA Phone with Bluetooth and WLAN; Serial: FI-035-A**

Communication System: GSM850 GPRS; 2 Tx slots; Frequency: 836.6 MHz; Duty Cycle: 1:4.15  
Medium: 835 Body Medium parameters used (interpolated):

$$f = 836.6 \text{ MHz}; \sigma = 0.96 \text{ mho/m}; \epsilon_r = 52.9; \rho = 1000 \text{ kg/m}^3$$

Phantom section: Flat Section; Space: 1.0 cm

Test Date: 02-28-2011; Ambient Temp: 23.7 °C; Tissue Temp: 22.0 °C

Probe: ES3DV2 - SN3022; ConvF(5.89, 5.89, 5.89); Calibrated: 9/21/2010

Sensor-Surface: 4mm (Mechanical Surface Detection)

Electronics: DAE4 Sn704; Calibrated: 3/22/2010

Phantom: SAM Sub; Type: SAM 4.0; Serial: TP-1403

Measurement SW: DASY4, V4.7 Build 80; Postprocessing SW: SEMCAD, V1.8 Build 186

**Mode: GPRS 850, Body SAR, Back side, Mid.ch, 2 Tx Slots**

**Area Scan (7x10x1):** Measurement grid: dx=15mm, dy=15mm

**Zoom Scan (5x5x7)/Cube 0:** Measurement grid: dx=8mm, dy=8mm, dz=5mm

Reference Value = 32.7 V/m

Peak SAR (extrapolated) = 1.30 W/kg

**SAR(1 g) = 0.963 mW/g; SAR(10 g) = 0.691 mW/g**

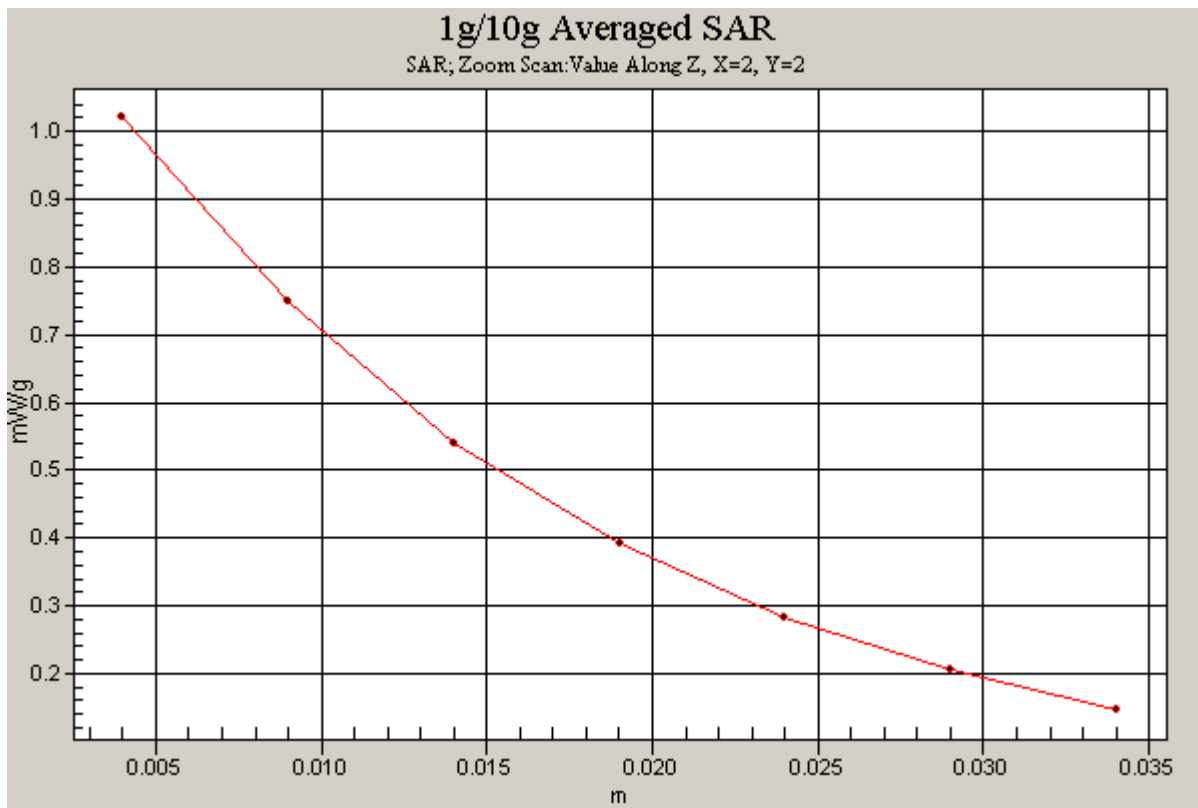

# PCTEST ENGINEERING LABORATORY, INC.

**DUT: A3LSGHT839; Type: 850/1900 GSM/GPRS/EDGE and 1700 WCDMA/HSPA Phone with Bluetooth and WLAN; Serial: FI-035-A**

Communication System: GSM850 GPRS; 2 Tx slots; Frequency: 836.6 MHz; Duty Cycle: 1:4.15  
Medium: 835 Body Medium parameters used (interpolated):

$$f = 836.6 \text{ MHz}; \sigma = 0.96 \text{ mho/m}; \epsilon_r = 52.9; \rho = 1000 \text{ kg/m}^3$$

Phantom section: Flat Section; Space: 1.0 cm

Test Date: 02-28-2011; Ambient Temp: 23.7 °C; Tissue Temp: 22.0 °C

Probe: ES3DV2 - SN3022; ConvF(5.89, 5.89, 5.89); Calibrated: 9/21/2010

Sensor-Surface: 4mm (Mechanical Surface Detection)

Electronics: DAE4 Sn704; Calibrated: 3/22/2010

Phantom: SAM Sub; Type: SAM 4.0; Serial: TP-1403

Measurement SW: DASY4, V4.7 Build 80; Postprocessing SW: SEMCAD, V1.8 Build 186

**Mode: GPRS 850, Body SAR, Front side, Mid.ch, 2 Tx Slots**

**Area Scan (7x10x1):** Measurement grid: dx=15mm, dy=15mm

**Zoom Scan (5x5x7)/Cube 0:** Measurement grid: dx=8mm, dy=8mm, dz=5mm

Reference Value = 20.6 V/m

Peak SAR (extrapolated) = 0.494 W/kg

**SAR(1 g) = 0.386 mW/g; SAR(10 g) = 0.292 mW/g**

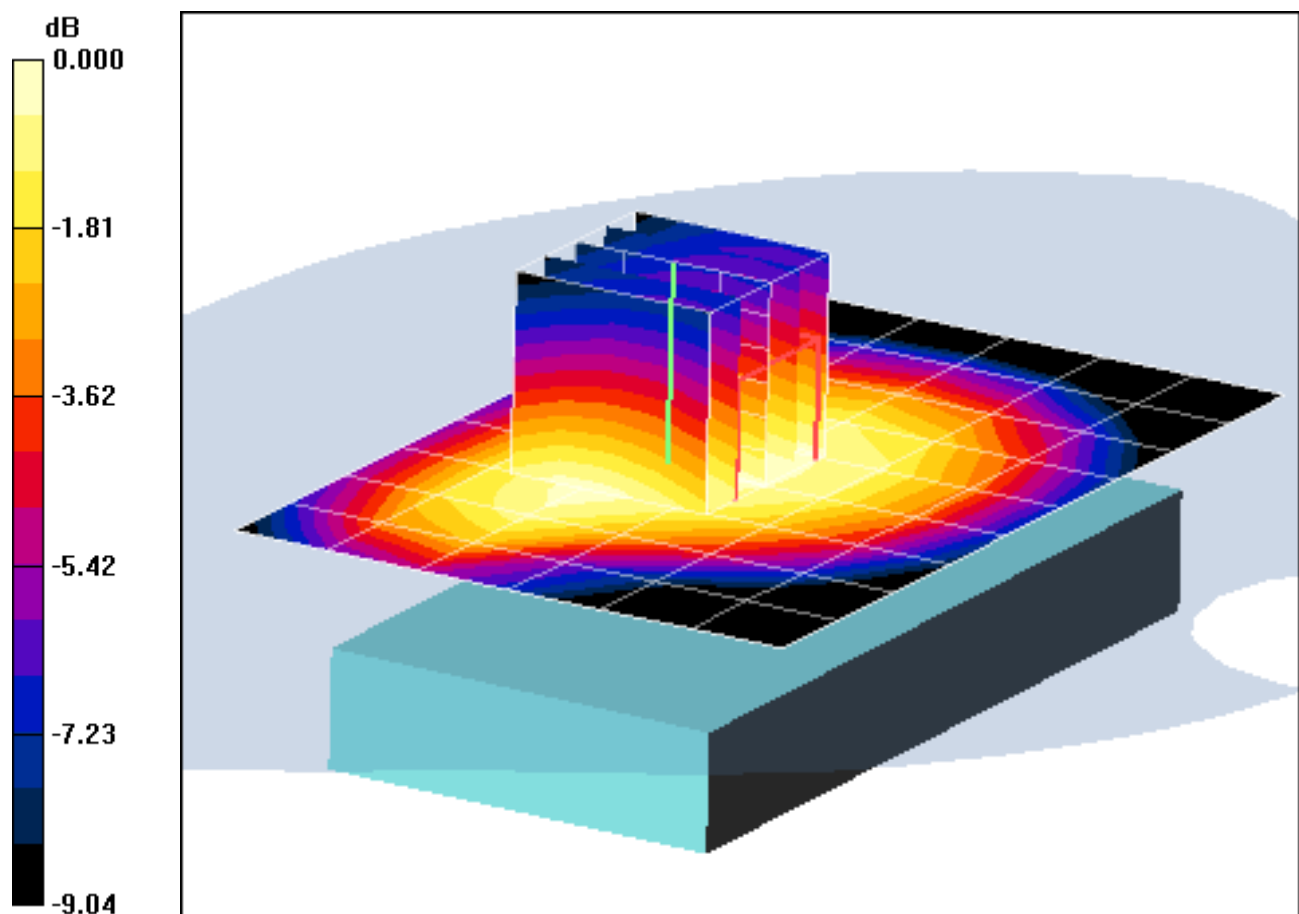

0 dB = 0.407mW/g

# PCTEST ENGINEERING LABORATORY, INC.

**DUT: A3LSGHT839; Type: 850/1900 GSM/GPRS/EDGE and 1700 WCDMA/HSPA Phone with Bluetooth and WLAN; Serial: FI-035-A**

Communication System: GSM850 GPRS; 2 Tx slots; Frequency: 836.6 MHz; Duty Cycle: 1:4.15  
Medium: 835 Body Medium parameters used (interpolated):

$$f = 836.6 \text{ MHz}; \sigma = 0.96 \text{ mho/m}; \epsilon_r = 52.9; \rho = 1000 \text{ kg/m}^3$$

Phantom section: Flat Section; Space: 1.5 cm

Test Date: 02-28-2011; Ambient Temp: 23.7 °C; Tissue Temp: 22.0 °C

Probe: ES3DV2 - SN3022; ConvF(5.89, 5.89, 5.89); Calibrated: 9/21/2010

Sensor-Surface: 4mm (Mechanical Surface Detection)

Electronics: DAE4 Sn704; Calibrated: 3/22/2010

Phantom: SAM Sub; Type: SAM 4.0; Serial: TP-1403

Measurement SW: DASY4, V4.7 Build 80; Postprocessing SW: SEMCAD, V1.8 Build 186

**Mode: GPRS 850, Body SAR, Bottom Edge, Mid.ch, 2 Tx Slots**

**Area Scan (5x7x1):** Measurement grid: dx=15mm, dy=15mm

**Zoom Scan (5x5x7)/Cube 0:** Measurement grid: dx=8mm, dy=8mm, dz=5mm

Reference Value = 8.98 V/m

Peak SAR (extrapolated) = 0.113 W/kg

**SAR(1 g) = 0.068 mW/g; SAR(10 g) = 0.042 mW/g**

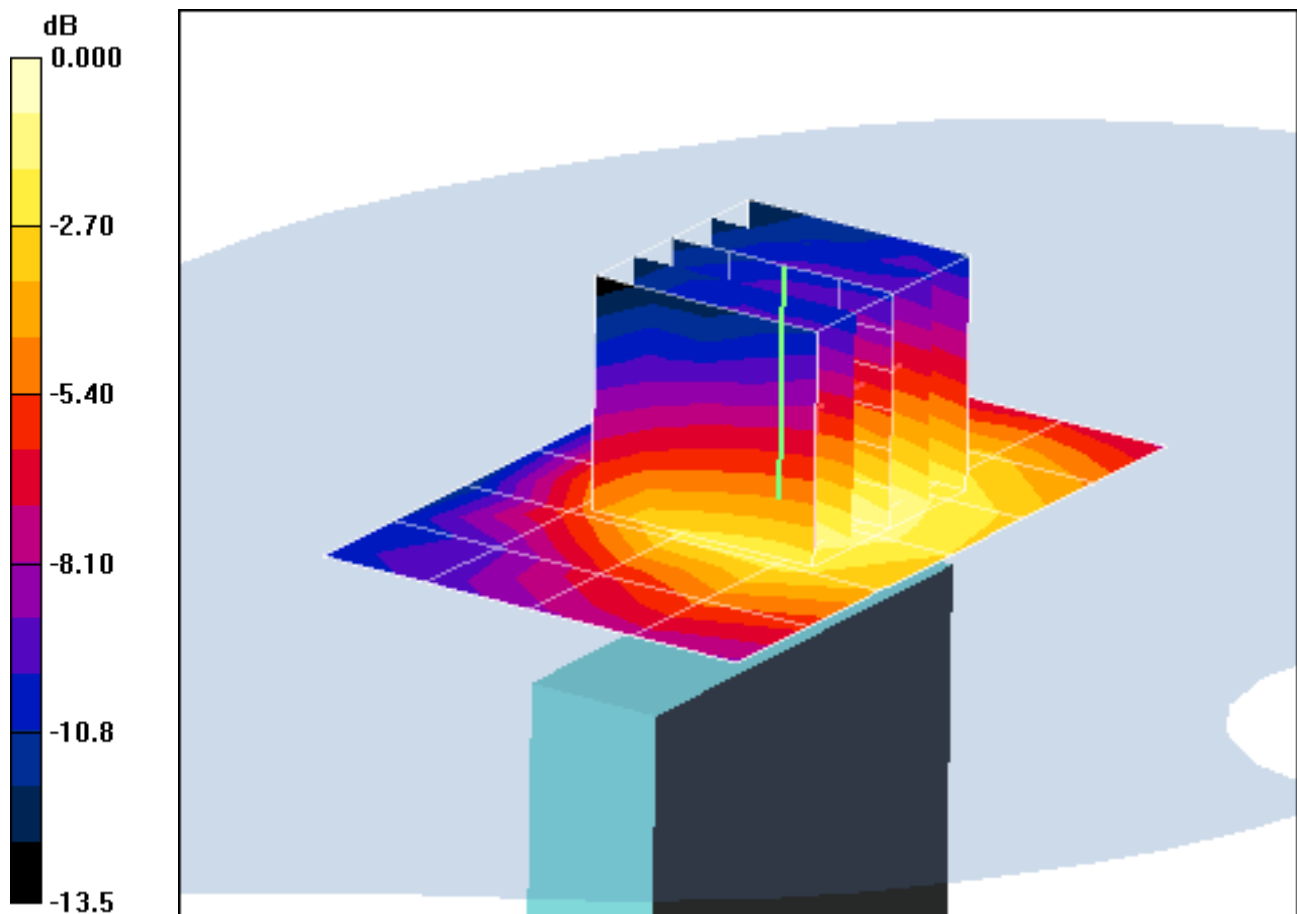

0 dB = 0.073mW/g

# PCTEST ENGINEERING LABORATORY, INC.

**DUT: A3LSGHT839; Type: 850/1900 GSM/GPRS/EDGE and 1700 WCDMA/HSPA Phone with Bluetooth and WLAN; Serial: FI-035-A**

Communication System: GSM850 GPRS; 2 Tx slots; Frequency: 836.6 MHz; Duty Cycle: 1:4.15  
Medium: 835 Body Medium parameters used (interpolated):

$$f = 836.6 \text{ MHz}; \sigma = 0.96 \text{ mho/m}; \epsilon_r = 52.9; \rho = 1000 \text{ kg/m}^3$$

Phantom section: Flat Section; Space: 1.0 cm

Test Date: 02-28-2011; Ambient Temp: 23.7 °C; Tissue Temp: 22.0 °C

Probe: ES3DV2 - SN3022; ConvF(5.89, 5.89, 5.89); Calibrated: 9/21/2010

Sensor-Surface: 4mm (Mechanical Surface Detection)

Electronics: DAE4 Sn704; Calibrated: 3/22/2010

Phantom: SAM Sub; Type: SAM 4.0; Serial: TP-1403

Measurement SW: DASY4, V4.7 Build 80; Postprocessing SW: SEMCAD, V1.8 Build 186

**Mode: GPRS 850, Body SAR, Right Edge, Mid.ch, 2 Tx Slots**

**Area Scan (5x13x1):** Measurement grid: dx=15mm, dy=15mm

**Zoom Scan (5x5x7)/Cube 0:** Measurement grid: dx=8mm, dy=8mm, dz=5mm

Reference Value = 22.8 V/m

Peak SAR (extrapolated) = 0.630 W/kg

**SAR(1 g) = 0.455 mW/g; SAR(10 g) = 0.315 mW/g**

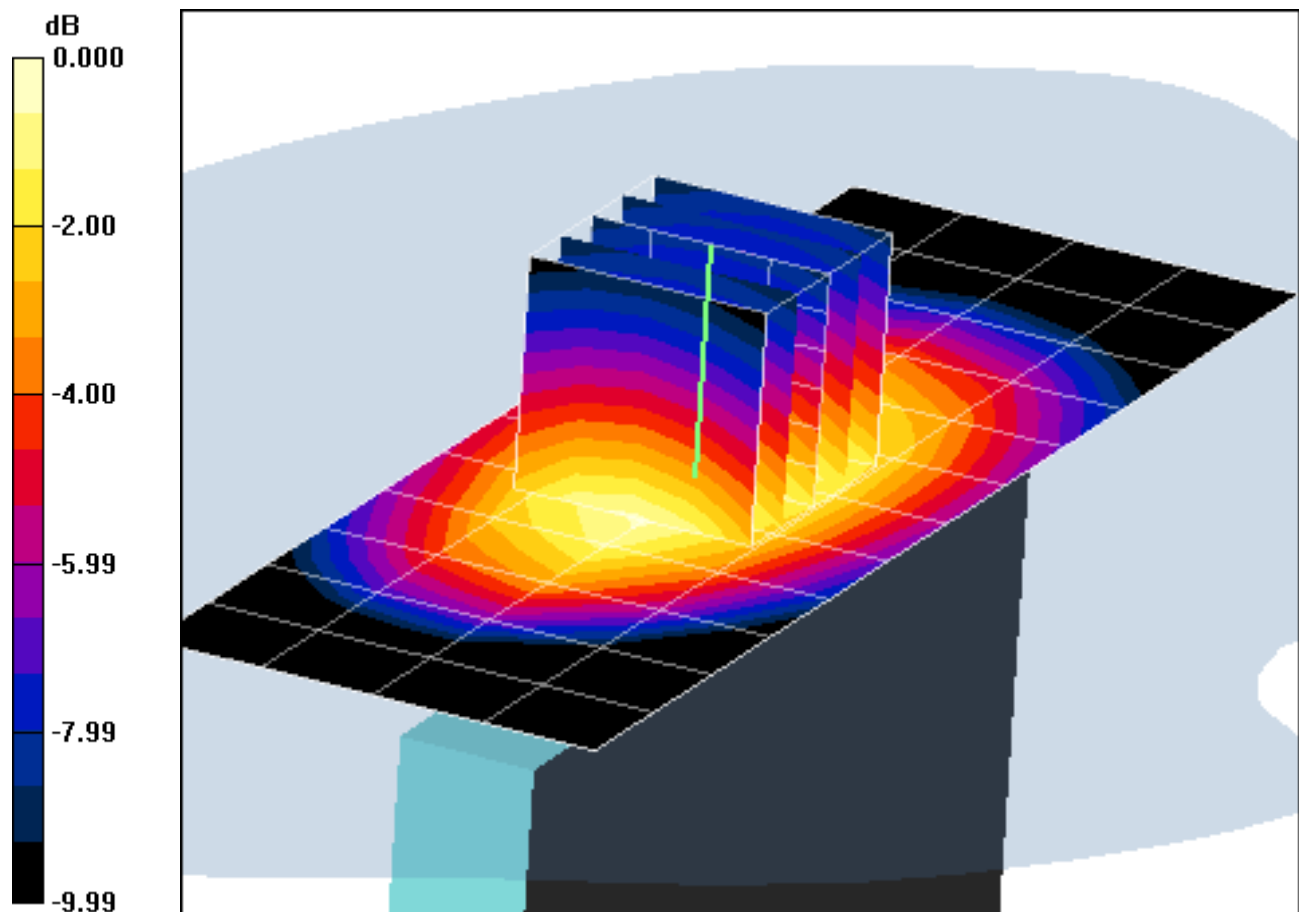

0 dB = 0.482mW/g

# PCTEST ENGINEERING LABORATORY, INC.

**DUT: A3LSGHT839; Type: 850/1900 GSM/GPRS/EDGE and 1700 WCDMA/HSPA Phone with Bluetooth and WLAN; Serial: FI-035-A**

Communication System: GSM850 GPRS; 2 Tx slots; Frequency: 836.6 MHz; Duty Cycle: 1:4.15  
Medium: 835 Body Medium parameters used (interpolated):

$$f = 836.6 \text{ MHz}; \sigma = 0.96 \text{ mho/m}; \epsilon_r = 52.9; \rho = 1000 \text{ kg/m}^3$$

Phantom section: Flat Section; Space: 1.0 cm

Test Date: 02-28-2011; Ambient Temp: 23.7 °C; Tissue Temp: 22.0 °C

Probe: ES3DV2 - SN3022; ConvF(5.89, 5.89, 5.89); Calibrated: 9/21/2010

Sensor-Surface: 4mm (Mechanical Surface Detection)

Electronics: DAE4 Sn704; Calibrated: 3/22/2010

Phantom: SAM Sub; Type: SAM 4.0; Serial: TP-1403

Measurement SW: DASY4, V4.7 Build 80; Postprocessing SW: SEMCAD, V1.8 Build 186

**Mode: GPRS 850, Body SAR, Left Edge, Mid.ch, 2 Tx Slots**

**Area Scan (5x13x1):** Measurement grid: dx=15mm, dy=15mm

**Zoom Scan (5x5x7)/Cube 0:** Measurement grid: dx=8mm, dy=8mm, dz=5mm

Reference Value = 20.2 V/m

Peak SAR (extrapolated) = 0.509 W/kg

**SAR(1 g) = 0.363 mW/g; SAR(10 g) = 0.252 mW/g**

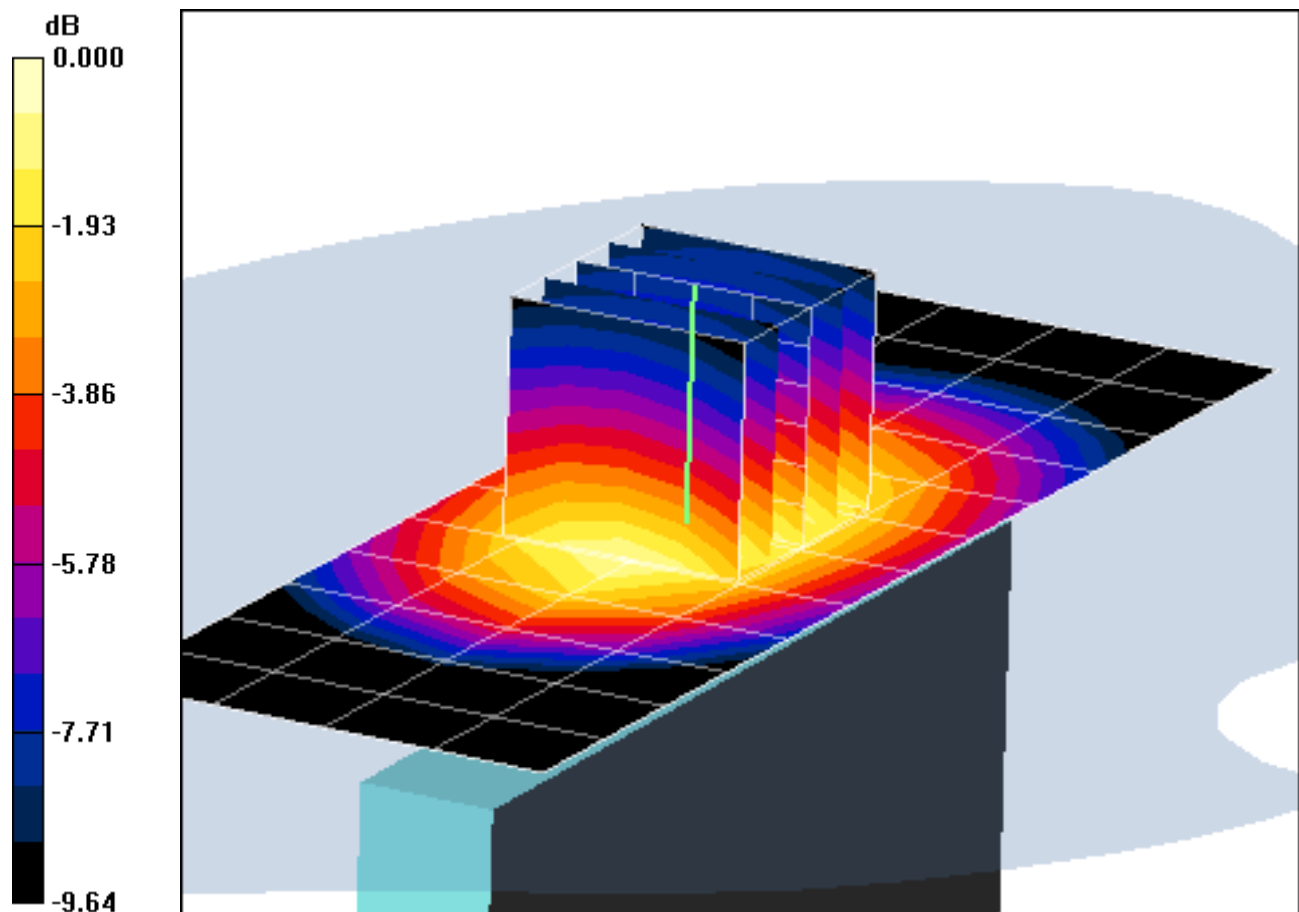

0 dB = 0.389mW/g

# PCTEST ENGINEERING LABORATORY, INC.

**DUT: A3LSGHT839; Type: 850/1900 GSM/GPRS/EDGE and 1700 WCDMA/HSPA Phone with Bluetooth and WLAN; Serial: FI-035-A**

Communication System: GSM1900 GPRS; 2 Tx slots; Frequency: 1880 MHz; Duty Cycle: 1:4.15

Medium: 1900 Body Medium parameters used:

$$f = 1880 \text{ MHz}; \sigma = 1.59 \text{ mho/m}; \epsilon_r = 51.1; \rho = 1000 \text{ kg/m}^3$$

Phantom section: Flat Section; Space: 1.0 cm

Test Date: 02-28-2011; Ambient Temp: 24.6 °C; Tissue Temp: 22.8 °C

Probe: EX3DV4 - SN3561; ConvF(6.59, 6.59, 6.59); Calibrated: 8/19/2010

Sensor-Surface: 4mm (Mechanical Surface Detection)

Electronics: DAE4 Sn665; Calibrated: 4/21/2010

Phantom: SAM with CRP; Type: SAM; Serial: TP1375

Measurement SW: DASY4, V4.7 Build 80; Postprocessing SW: SEMCAD, V1.8 Build 186

**Mode: GPRS 1900, Body SAR, Back side, Mid.ch, 2 Tx Slots**

**Area Scan (7x10x1):** Measurement grid: dx=15mm, dy=15mm

**Zoom Scan (5x5x7)/Cube 0:** Measurement grid: dx=8mm, dy=8mm, dz=5mm

Reference Value = 20.3 V/m

Peak SAR (extrapolated) = 1.11 W/kg

**SAR(1 g) = 0.682 mW/g; SAR(10 g) = 0.416 mW/g**

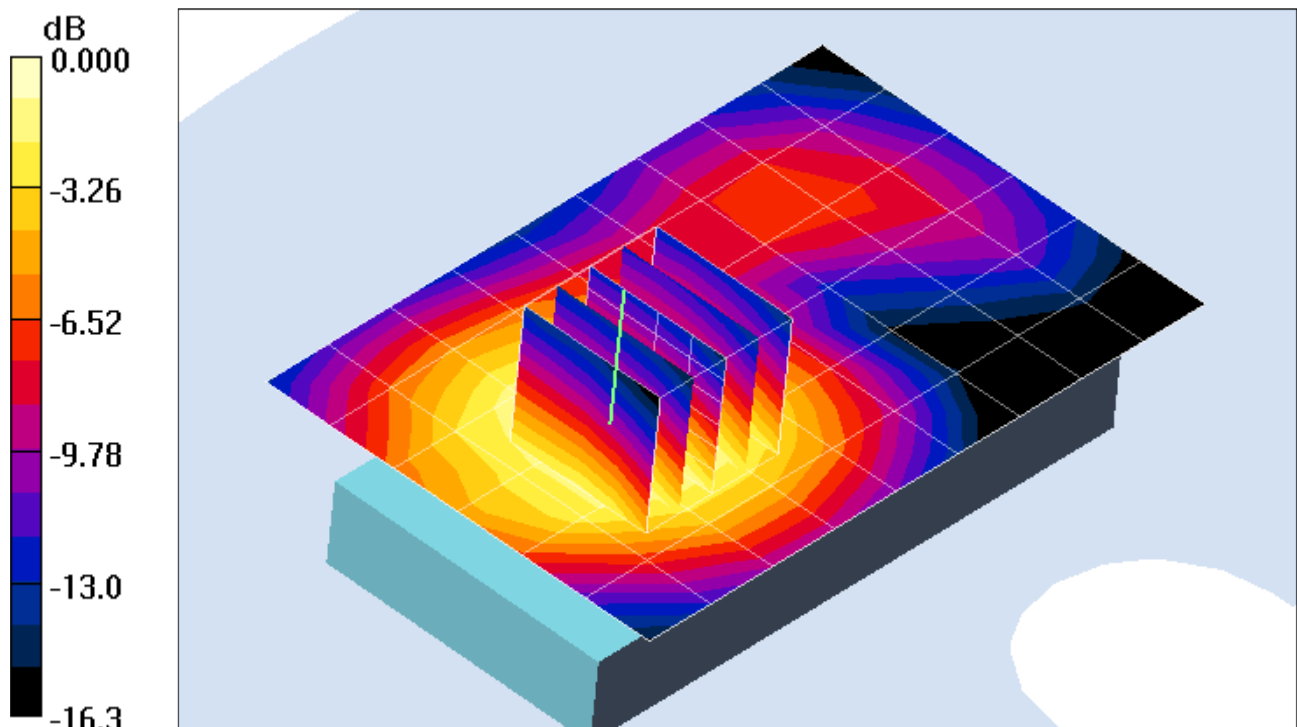

0 dB = 0.733mW/g

# PCTEST ENGINEERING LABORATORY, INC.

**DUT: A3LSGHT839; Type: 850/1900 GSM/GPRS/EDGE and 1700 WCDMA/HSPA Phone with Bluetooth and WLAN; Serial: FI-035-A**

Communication System: GSM1900 GPRS; 2 Tx slots; Frequency: 1880 MHz; Duty Cycle: 1:4.15

Medium: 1900 Body Medium parameters used:

$$f = 1880 \text{ MHz}; \sigma = 1.59 \text{ mho/m}; \epsilon_r = 51.1; \rho = 1000 \text{ kg/m}^3$$

Phantom section: Flat Section; Space: 1.0 cm

Test Date: 02-28-2011; Ambient Temp: 24.6 °C; Tissue Temp: 22.8 °C

Probe: EX3DV4 - SN3561; ConvF(6.59, 6.59, 6.59); Calibrated: 8/19/2010

Sensor-Surface: 4mm (Mechanical Surface Detection)

Electronics: DAE4 Sn665; Calibrated: 4/21/2010

Phantom: SAM with CRP; Type: SAM; Serial: TP1375

Measurement SW: DASY4, V4.7 Build 80; Postprocessing SW: SEMCAD, V1.8 Build 186

**Mode: GPRS 1900, Body SAR, Back side, Mid.ch, 2 Tx Slots**

**Area Scan (7x10x1):** Measurement grid: dx=15mm, dy=15mm

**Zoom Scan (5x5x7)/Cube 0:** Measurement grid: dx=8mm, dy=8mm, dz=5mm

Reference Value = 20.3 V/m

Peak SAR (extrapolated) = 1.11 W/kg

**SAR(1 g) = 0.682 mW/g; SAR(10 g) = 0.416 mW/g**

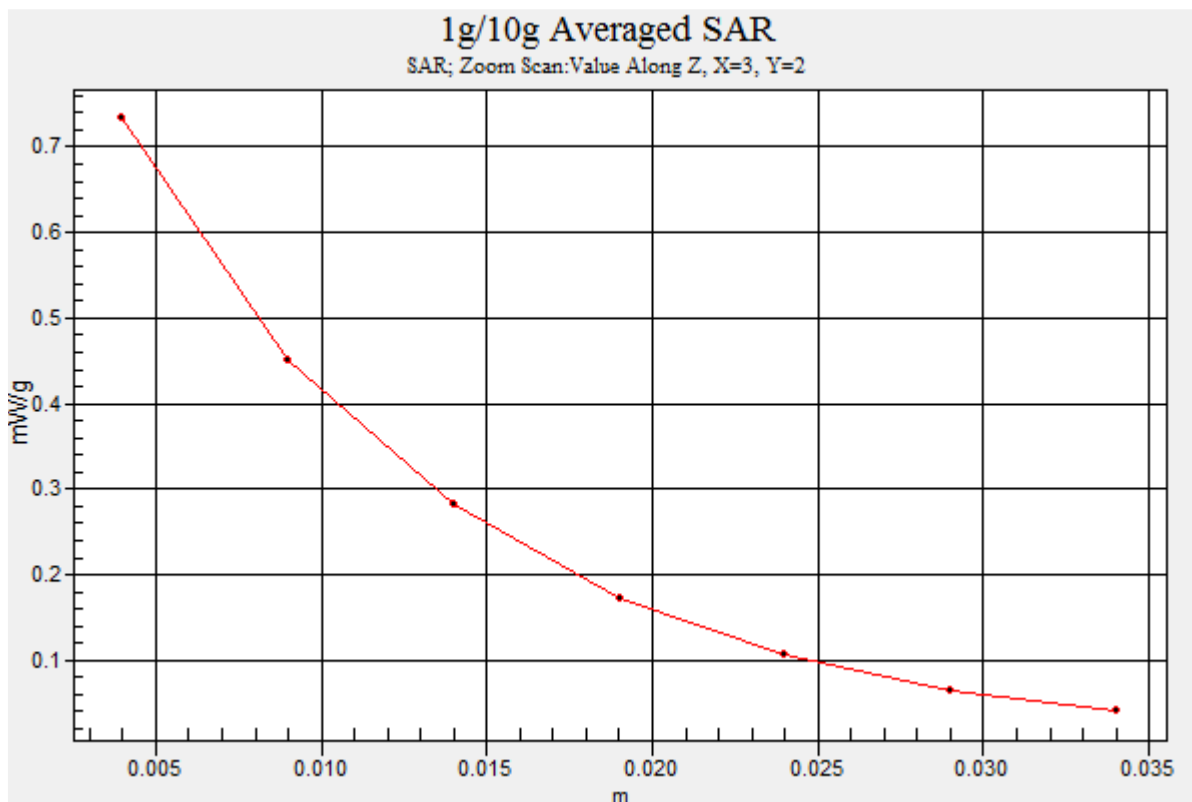

# PCTEST ENGINEERING LABORATORY, INC.

**DUT: A3LSGHT839; Type: 850/1900 GSM/GPRS/EDGE and 1700 WCDMA/HSPA Phone with Bluetooth and WLAN; Serial: FI-035-A**

Communication System: GSM1900 GPRS; 2 Tx slots; Frequency: 1880 MHz; Duty Cycle: 1:4.15  
Medium: 1900 Body Medium parameters used:

$$f = 1880 \text{ MHz}; \sigma = 1.59 \text{ mho/m}; \epsilon_r = 51.1; \rho = 1000 \text{ kg/m}^3$$

Phantom section: Flat Section; Space: 1.0 cm

Test Date: 02-28-2011; Ambient Temp: 24.6 °C; Tissue Temp: 22.8 °C

Probe: EX3DV4 - SN3561; ConvF(6.59, 6.59, 6.59); Calibrated: 8/19/2010

Sensor-Surface: 4mm (Mechanical Surface Detection)

Electronics: DAE4 Sn665; Calibrated: 4/21/2010

Phantom: SAM with CRP; Type: SAM; Serial: TP1375

Measurement SW: DASY4, V4.7 Build 80; Postprocessing SW: SEMCAD, V1.8 Build 186

**Mode: GPRS 1900, Body SAR, Front side, Mid.ch, 2 Tx Slots**

**Area Scan (7x10x1):** Measurement grid: dx=15mm, dy=15mm

**Zoom Scan (5x5x7)/Cube 0:** Measurement grid: dx=8mm, dy=8mm, dz=5mm

Reference Value = 17.0 V/m

Peak SAR (extrapolated) = 0.770 W/kg

**SAR(1 g) = 0.460 mW/g; SAR(10 g) = 0.274 mW/g**

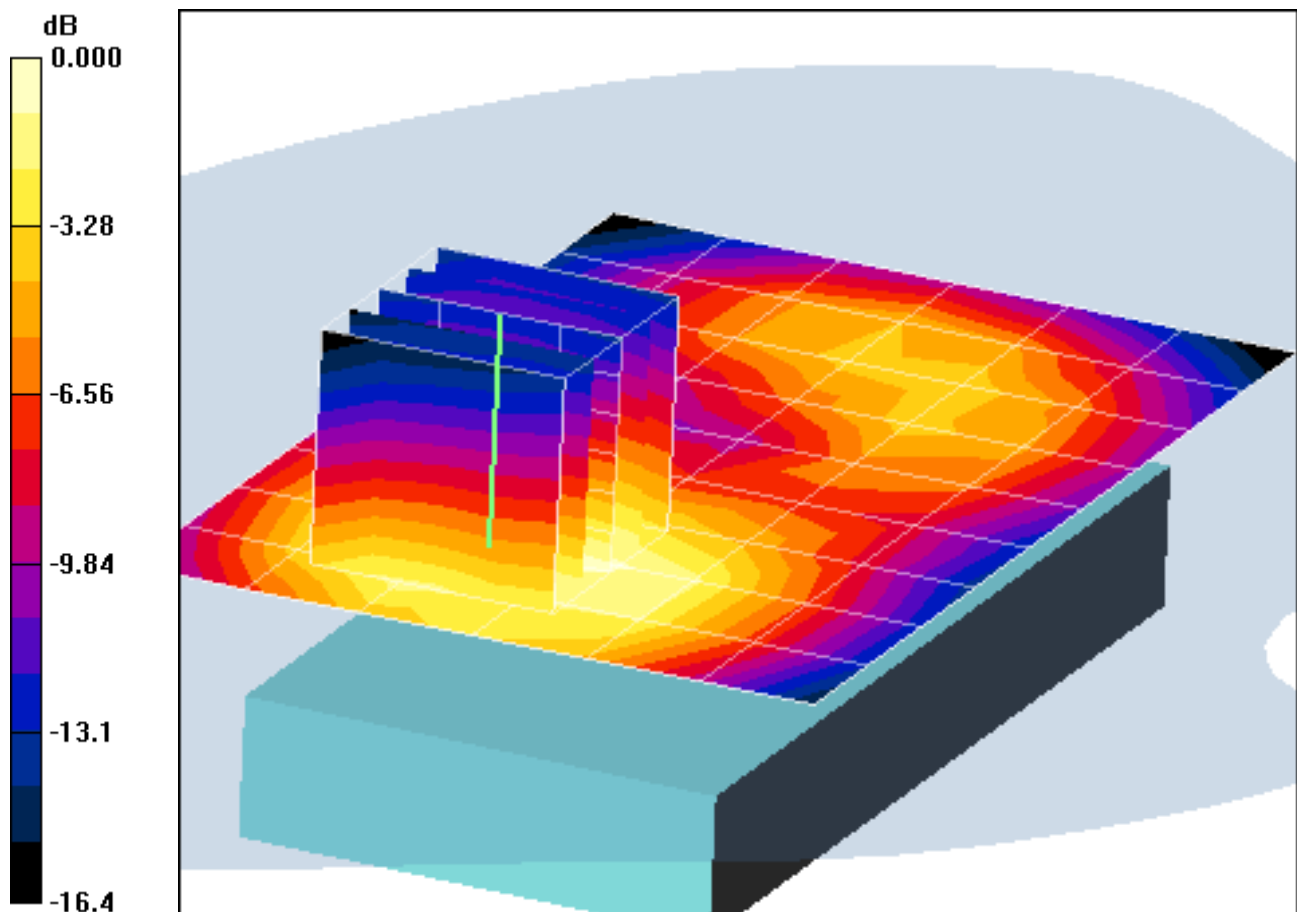

0 dB = 0.502mW/g

# PCTEST ENGINEERING LABORATORY, INC.

**DUT: A3LSGHT839; Type: 850/1900 GSM/GPRS/EDGE and 1700 WCDMA/HSPA Phone with Bluetooth and WLAN; Serial: FI-035-A**

Communication System: GSM1900 GPRS; 2 Tx slots; Frequency: 1880 MHz; Duty Cycle: 1:4.15  
Medium: 1900 Body Medium parameters used:

$$f = 1880 \text{ MHz}; \sigma = 1.59 \text{ mho/m}; \epsilon_r = 51.1; \rho = 1000 \text{ kg/m}^3$$

Phantom section: Flat Section; Space: 1.0 cm

Test Date: 02-28-2011; Ambient Temp: 24.6 °C; Tissue Temp: 22.8 °C

Probe: EX3DV4 - SN3561; ConvF(6.59, 6.59, 6.59); Calibrated: 8/19/2010

Sensor-Surface: 4mm (Mechanical Surface Detection)

Electronics: DAE4 Sn665; Calibrated: 4/21/2010

Phantom: SAM with CRP; Type: SAM; Serial: TP1375

Measurement SW: DASY4, V4.7 Build 80; Postprocessing SW: SEMCAD, V1.8 Build 186

**Mode: GPRS 1900, Body SAR, Bottom Edge, Mid.ch, 2 Tx Slots**

**Area Scan (5x7x1):** Measurement grid: dx=15mm, dy=15mm

**Zoom Scan (5x5x7)/Cube 0:** Measurement grid: dx=8mm, dy=8mm, dz=5mm

Reference Value = 14.2 V/m

Peak SAR (extrapolated) = 0.568 W/kg

**SAR(1 g) = 0.341 mW/g; SAR(10 g) = 0.193 mW/g**

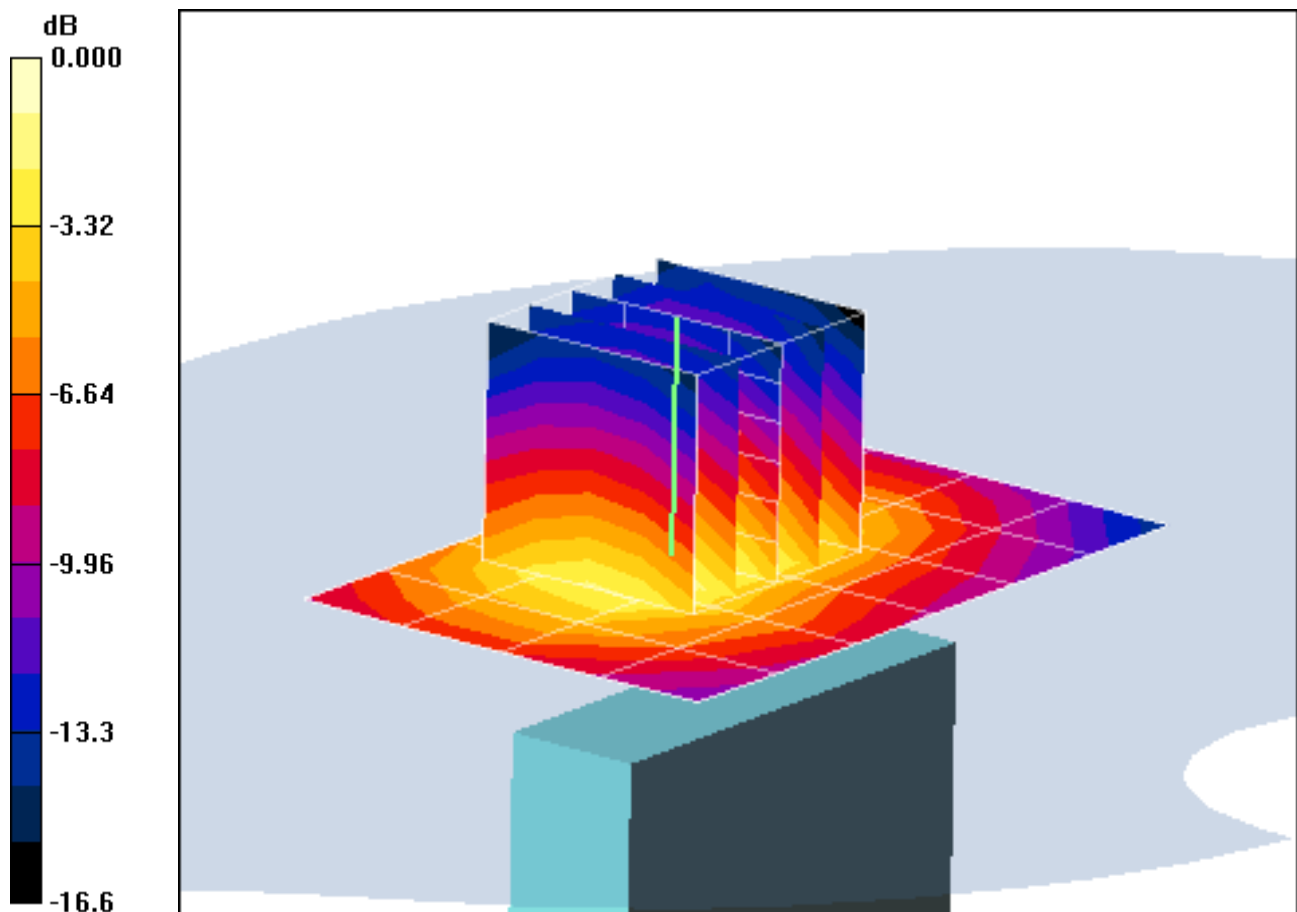

0 dB = 0.378mW/g

# PCTEST ENGINEERING LABORATORY, INC.

**DUT: A3LSGHT839; Type: 850/1900 GSM/GPRS/EDGE and 1700 WCDMA/HSPA Phone with Bluetooth and WLAN; Serial: FI-035-A**

Communication System: GSM1900 GPRS; 2 Tx slots; Frequency: 1880 MHz; Duty Cycle: 1:4.15  
Medium: 1900 Body Medium parameters used:

$$f = 1880 \text{ MHz}; \sigma = 1.59 \text{ mho/m}; \epsilon_r = 51.1; \rho = 1000 \text{ kg/m}^3$$

Phantom section: Flat Section; Space: 1.0 cm

Test Date: 02-28-2011; Ambient Temp: 24.6 °C; Tissue Temp: 22.8 °C

Probe: EX3DV4 - SN3561; ConvF(6.59, 6.59, 6.59); Calibrated: 8/19/2010

Sensor-Surface: 4mm (Mechanical Surface Detection)

Electronics: DAE4 Sn665; Calibrated: 4/21/2010

Phantom: SAM with CRP; Type: SAM; Serial: TP1375

Measurement SW: DASY4, V4.7 Build 80; Postprocessing SW: SEMCAD, V1.8 Build 186

**Mode: GPRS 1900, Body SAR, Right Edge, Mid.ch, 2 Tx Slots**

**Area Scan (5x13x1):** Measurement grid: dx=15mm, dy=15mm

**Zoom Scan (5x5x7)/Cube 0:** Measurement grid: dx=8mm, dy=8mm, dz=5mm

Reference Value = 11.6 V/m

Peak SAR (extrapolated) = 0.329 W/kg

**SAR(1 g) = 0.202 mW/g; SAR(10 g) = 0.117 mW/g**

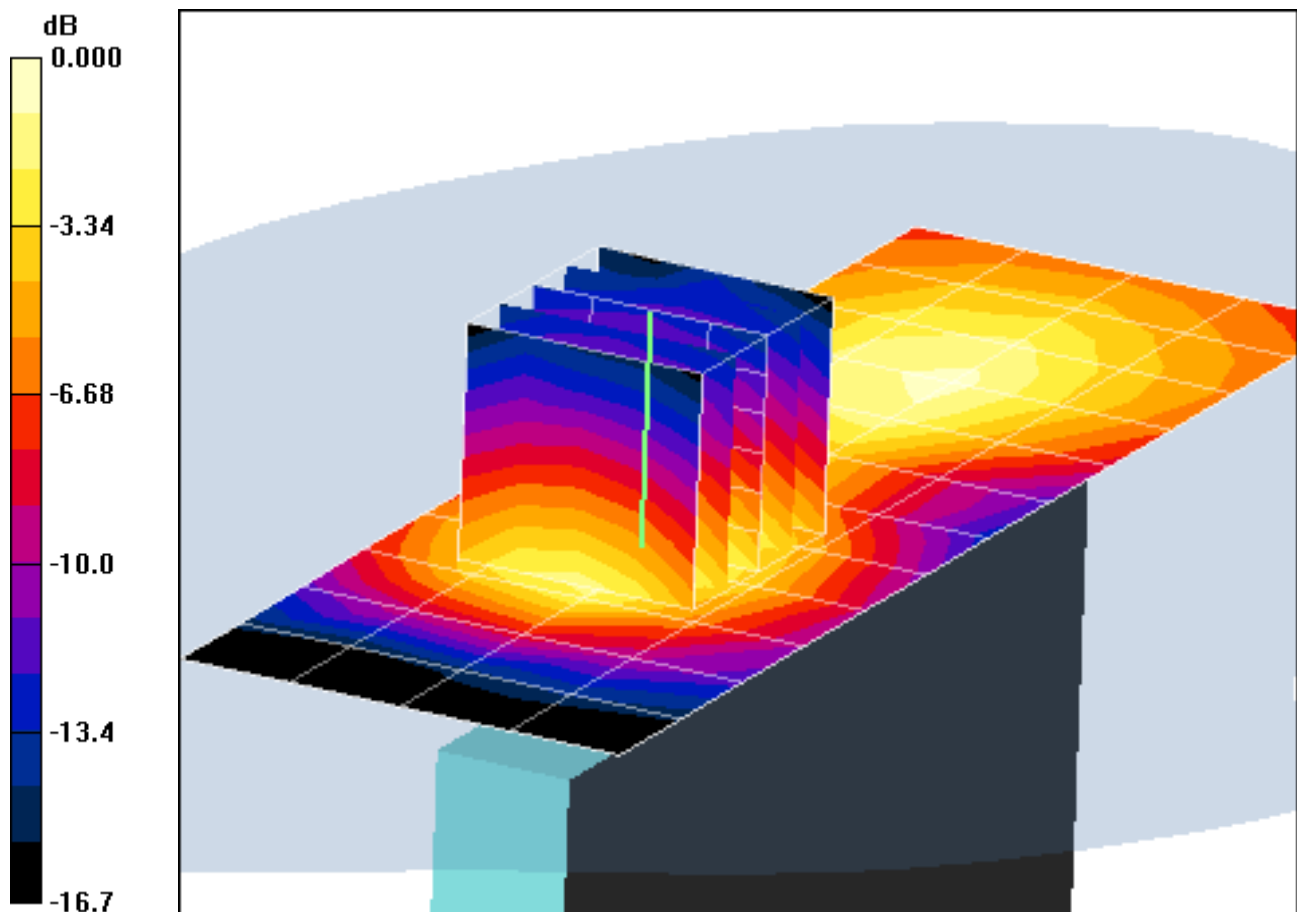

0 dB = 0.220mW/g

# PCTEST ENGINEERING LABORATORY, INC.

**DUT: A3LSGHT839; Type: 850/1900 GSM/GPRS/EDGE and 1700 WCDMA/HSPA Phone with Bluetooth and WLAN; Serial: FI-035-A**

Communication System: GSM1900 GPRS; 2 Tx slots; Frequency: 1880 MHz; Duty Cycle: 1:4.15  
Medium: 1900 Body Medium parameters used:

$$f = 1880 \text{ MHz}; \sigma = 1.59 \text{ mho/m}; \epsilon_r = 51.1; \rho = 1000 \text{ kg/m}^3$$

Phantom section: Flat Section; Space: 1.0 cm

Test Date: 02-28-2011; Ambient Temp: 24.6 °C; Tissue Temp: 22.8 °C

Probe: EX3DV4 - SN3561; ConvF(6.59, 6.59, 6.59); Calibrated: 8/19/2010

Sensor-Surface: 4mm (Mechanical Surface Detection)

Electronics: DAE4 Sn665; Calibrated: 4/21/2010

Phantom: SAM with CRP; Type: SAM; Serial: TP1375

Measurement SW: DASY4, V4.7 Build 80; Postprocessing SW: SEMCAD, V1.8 Build 186

**Mode: GPRS 1900, Body SAR, Left Edge, Mid.ch, 2 Tx Slots**

**Area Scan (5x13x1):** Measurement grid: dx=15mm, dy=15mm

**Zoom Scan (5x5x7)/Cube 0:** Measurement grid: dx=8mm, dy=8mm, dz=5mm

Reference Value = 11.5 V/m

Peak SAR (extrapolated) = 0.365 W/kg

**SAR(1 g) = 0.215 mW/g; SAR(10 g) = 0.123 mW/g**

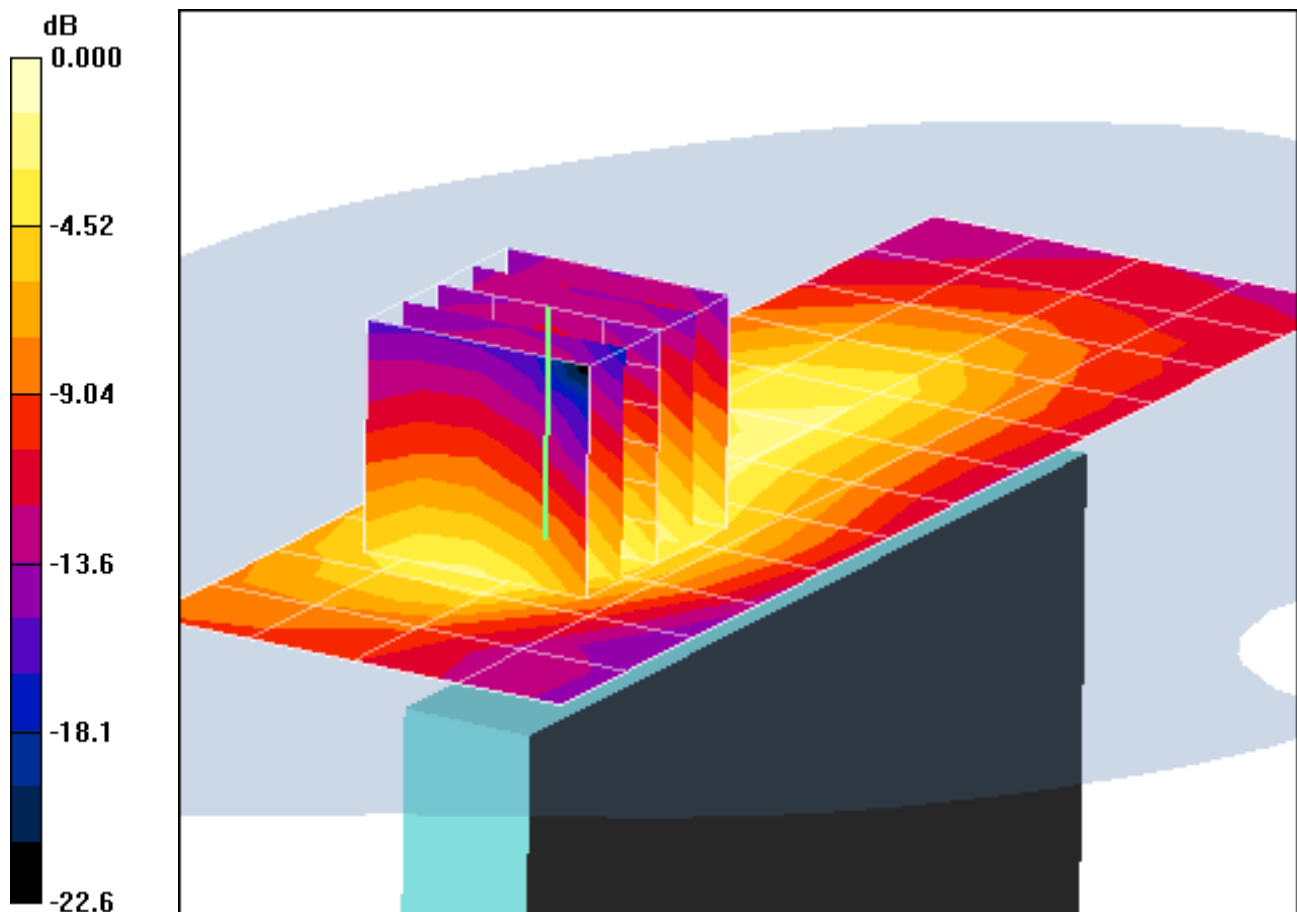

0 dB = 0.234mW/g

# PCTEST ENGINEERING LABORATORY, INC.

**DUT: A3LSGHT839; Type: 850/1900 GSM/GPRS/EDGE and 1700 WCDMA/HSPA Phone with Bluetooth and WLAN; Serial: FI-035-A**

Communication System: WCDMA1700; Frequency: 1730.4 MHz; Duty Cycle: 1:1  
Medium: 1750 Body Medium parameters used (interpolated):  
 $f = 1730.4 \text{ MHz}$ ;  $\sigma = 1.54 \text{ mho/m}$ ;  $\epsilon_r = 53.6$ ;  $\rho = 1000 \text{ kg/m}^3$   
Phantom section: Flat Section; Space: 1.0 cm

Test Date: 03-04-2011; Ambient Temp: 25.5 °C ; Tissue Temp: 21.6 °C

Probe: EX3DV4 - SN3550; ConvF(7.21, 7.21, 7.21); Calibrated: 2/14/2011  
Sensor-Surface: 4mm (Mechanical Surface Detection)  
Electronics: DAE4 Sn859; Calibrated: 7/8/2010  
Phantom: SAM Sub; Type: SAM 4.0; Serial: TP-1357  
Measurement SW: DASY4, V4.7 Build 80; Postprocessing SW: SEMCAD, V1.8 Build 186

**Mode: WCDMA 1700, Body SAR, Back side, Mid.ch**

**Area Scan (7x12x1):** Measurement grid: dx=15mm, dy=15mm  
**Zoom Scan (5x5x7)/Cube 0:** Measurement grid: dx=8mm, dy=8mm, dz=5mm  
Reference Value = 23.3 V/m  
Peak SAR (extrapolated) = 1.34 W/kg  
**SAR(1 g) = 0.809 mW/g; SAR(10 g) = 0.473 mW/g**

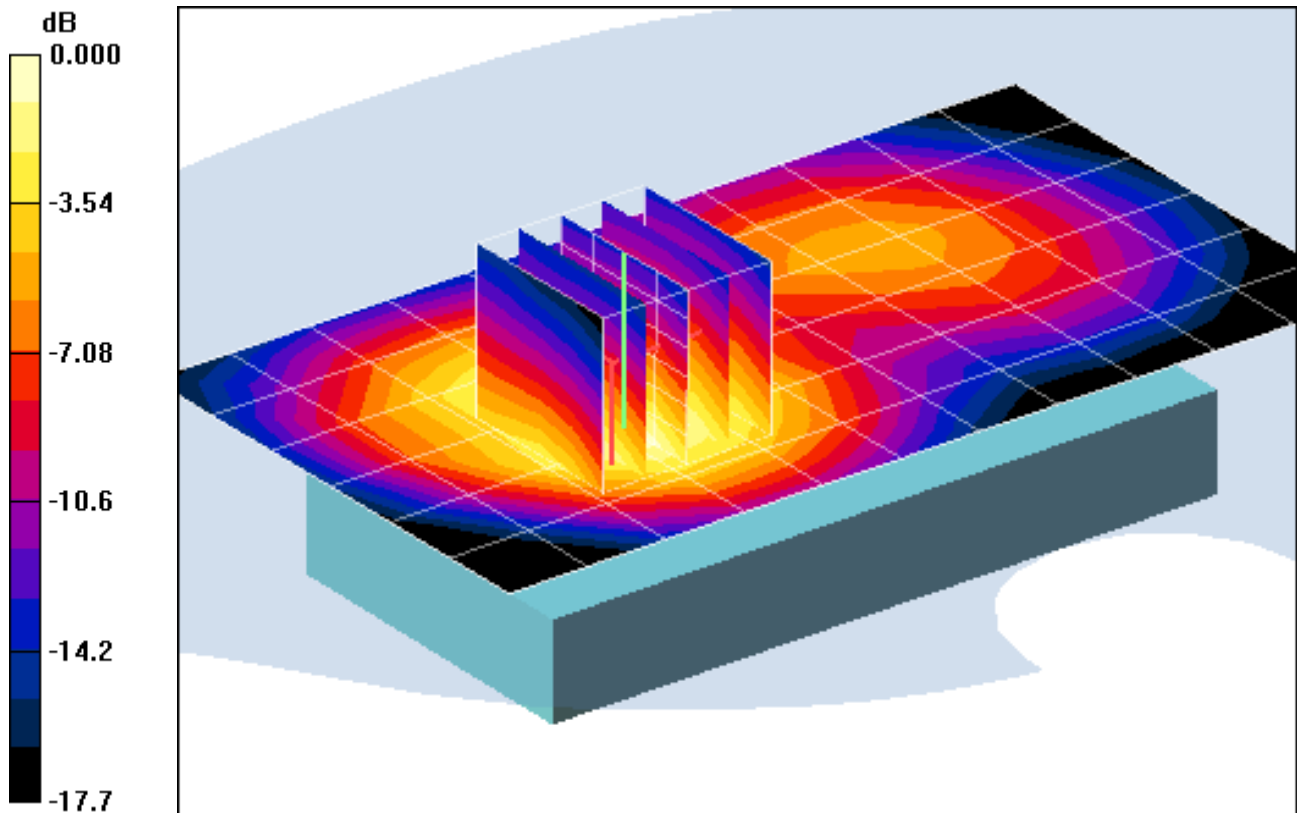

0 dB = 0.887mW/g

# PCTEST ENGINEERING LABORATORY, INC.

**DUT: A3LSGHT839; Type: 850/1900 GSM/GPRS/EDGE and 1700 WCDMA/HSPA Phone with Bluetooth and WLAN; Serial: FI-035-A**

Communication System: WCDMA1700; Frequency: 1730.4 MHz; Duty Cycle: 1:1  
Medium: 1750 Body Medium parameters used (interpolated):  
 $f = 1730.4 \text{ MHz}$ ;  $\sigma = 1.54 \text{ mho/m}$ ;  $\epsilon_r = 53.6$ ;  $\rho = 1000 \text{ kg/m}^3$   
Phantom section: Flat Section; Space: 1.0 cm

Test Date: 03-04-2011; Ambient Temp: 45.0 °C

Probe: EX3DV4 - SN3550; ConvF(7.21, 7.21, 7.21); Calibrated: 2/14/2011  
Sensor-Surface: 4mm (Mechanical Surface Detection)  
Electronics: DAE4 Sn859; Calibrated: 7/8/2010  
Phantom: SAM Sub; Type: SAM 4.0; Serial: TP-1357  
Measurement SW: DASY4, V4.7 Build 80; Postprocessing SW: SEMCAD, V1.8 Build 186

**Mode: WCDMA 1700, Body SAR, Back side, Mid.ch**

**Area Scan (7x12x1):** Measurement grid: dx=15mm, dy=15mm  
**Zoom Scan (5x5x7)/Cube 0:** Measurement grid: dx=8mm, dy=8mm, dz=5mm  
Reference Value = 23.3 V/m  
Peak SAR (extrapolated) = 1.34 W/kg  
**SAR(1 g) = 0.809 mW/g; SAR(10 g) = 0.473 mW/g**

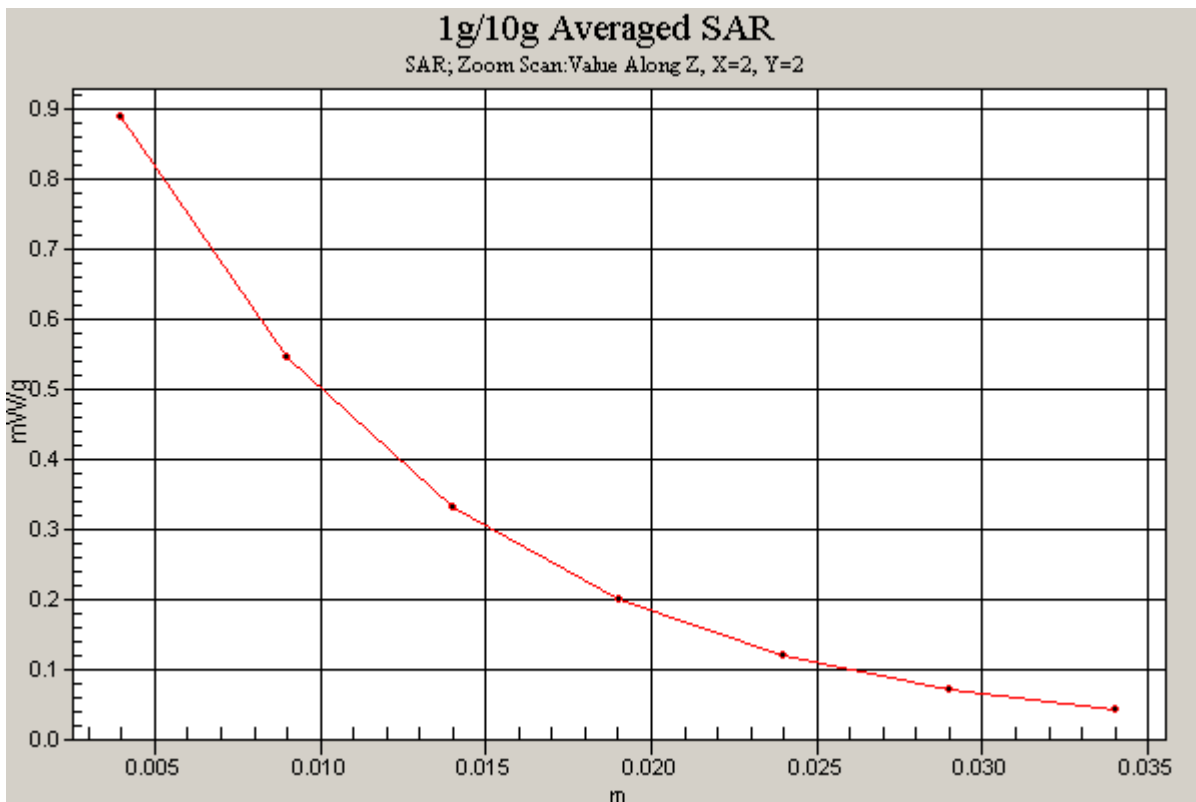

# PCTEST ENGINEERING LABORATORY, INC.

**DUT: A3LSGHT839; Type: 850/1900 GSM/GPRS/EDGE and 1700 WCDMA/HSPA Phone with Bluetooth and WLAN; Serial: FI-035-A**

Communication System: WCDMA1700; Frequency: 1730.4 MHz; Duty Cycle: 1:1  
Medium: 1750 Body Medium parameters used (interpolated):  
 $f = 1730.4 \text{ MHz}$ ;  $\sigma = 1.54 \text{ mho/m}$ ;  $\epsilon_r = 53.6$ ;  $\rho = 1000 \text{ kg/m}^3$   
Phantom section: Flat Section; Space: 1.0 cm

Test Date: 03-04-2011; Ambient Temp: 43.62 °C

Probe: EX3DV4 - SN3550; ConvF(7.21, 7.21, 7.21); Calibrated: 2/14/2011  
Sensor-Surface: 4mm (Mechanical Surface Detection)  
Electronics: DAE4 Sn859; Calibrated: 7/8/2010  
Phantom: SAM Sub; Type: SAM 4.0; Serial: TP-1357

Measurement SW: DASY4, V4.7 Build 80; Postprocessing SW: SEMCAD, V1.8 Build 186

**Mode: WCDMA 1700, Body SAR, Front side, Mid.ch**

**Area Scan (7x12x1):** Measurement grid: dx=15mm, dy=15mm

**Zoom Scan (5x5x7)/Cube 0:** Measurement grid: dx=8mm, dy=8mm, dz=5mm

Reference Value = 18.0 V/m

Peak SAR (extrapolated) = 0.770 W/kg

**SAR(1 g) = 0.466 mW/g; SAR(10 g) = 0.274 mW/g**

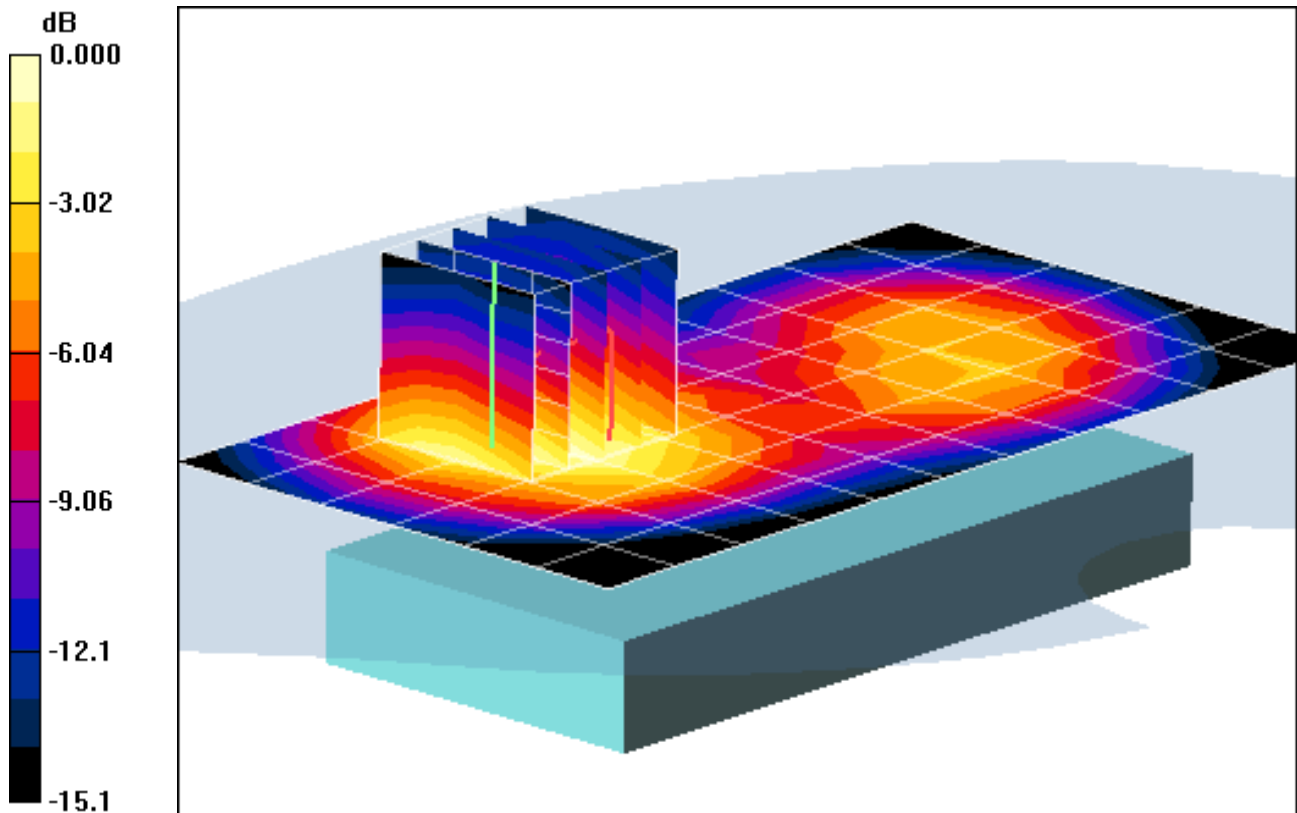

0 dB = 0.496mW/g

# PCTEST ENGINEERING LABORATORY, INC.

**DUT: A3LSGHT839; Type: 850/1900 GSM/GPRS/EDGE and 1700 WCDMA/HSPA Phone with Bluetooth and WLAN; Serial: FI-035-A**

Communication System: WCDMA1700; Frequency: 1730.4 MHz; Duty Cycle: 1:1  
Medium: 1750 Body Medium parameters used (interpolated):  
 $f = 1730.4 \text{ MHz}$ ;  $\sigma = 1.54 \text{ mho/m}$ ;  $\epsilon_r = 53.6$ ;  $\rho = 1000 \text{ kg/m}^3$   
Phantom section: Flat Section; Space: 1.0 cm

Test Date: 03-04-2011; Ambient Temp: 45.0 °C

Probe: EX3DV4 - SN3550; ConvF(7.21, 7.21, 7.21); Calibrated: 2/14/2011  
Sensor-Surface: 4mm (Mechanical Surface Detection)  
Electronics: DAE4 Sn859; Calibrated: 7/8/2010  
Phantom: SAM Sub; Type: SAM 4.0; Serial: TP-1357

Measurement SW: DASY4, V4.7 Build 80; Postprocessing SW: SEMCAD, V1.8 Build 186

**Mode: WCDMA 1700, Body SAR, Bottom Edge, Mid.ch**

**Area Scan (7x8x1):** Measurement grid: dx=15mm, dy=15mm

**Zoom Scan (5x5x7)/Cube 0:** Measurement grid: dx=8mm, dy=8mm, dz=5mm

Reference Value = 15.6 V/m

Peak SAR (extrapolated) = 0.549 W/kg

**SAR(1 g) = 0.341 mW/g; SAR(10 g) = 0.195 mW/g**

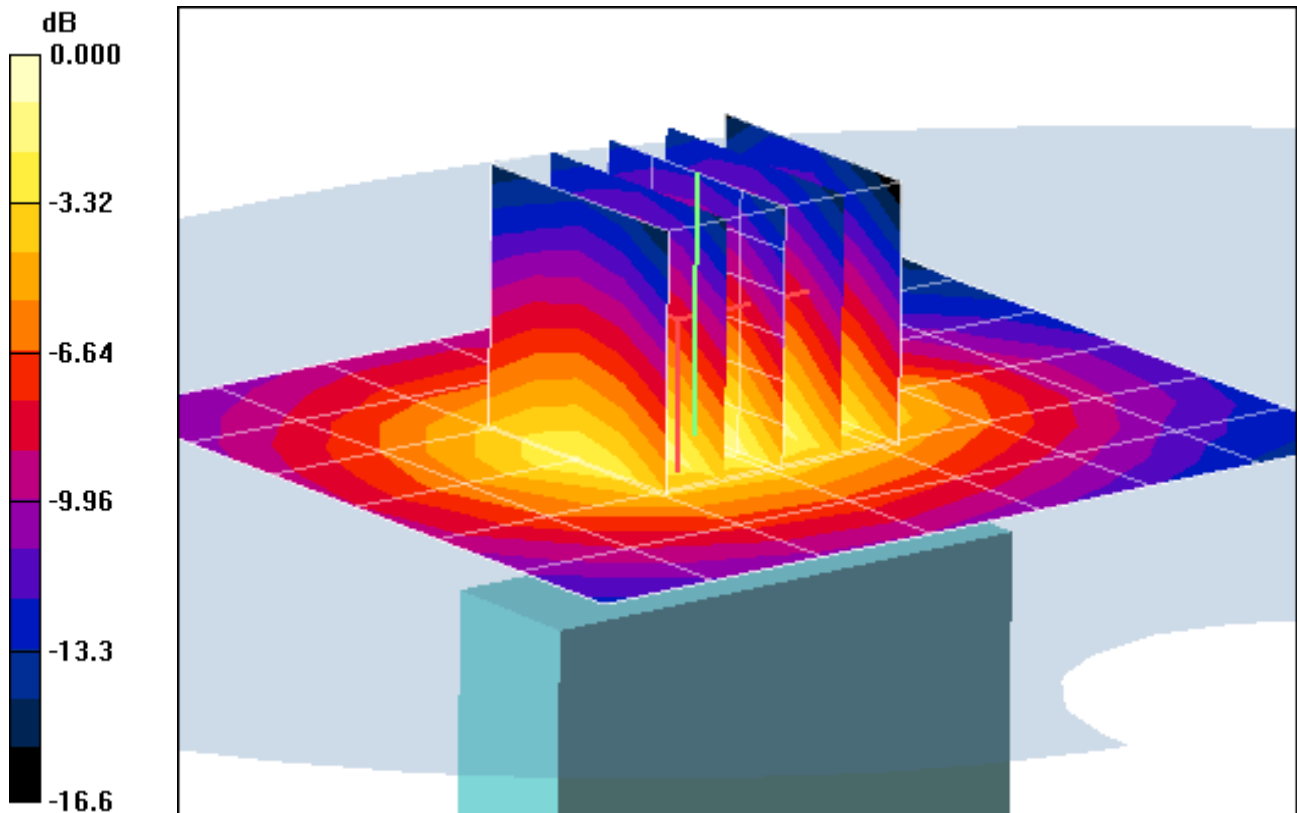

0 dB = 0.379mW/g

# PCTEST ENGINEERING LABORATORY, INC.

**DUT: A3LSGHT839; Type: 850/1900 GSM/GPRS/EDGE and 1700 WCDMA/HSPA Phone with Bluetooth and WLAN; Serial: FI-035-A**

Communication System: WCDMA1700; Frequency: 1730.4 MHz; Duty Cycle: 1:1  
Medium: 1750 Body Medium parameters used (interpolated):  
 $f = 1730.4 \text{ MHz}$ ;  $\sigma = 1.54 \text{ mho/m}$ ;  $\epsilon_r = 53.6$ ;  $\rho = 1000 \text{ kg/m}^3$   
Phantom section: Flat Section; Space: 1.0 cm

Test Date: 03-04-2011; Ambient Temp: 23.3 °C ; Tissue Temp: 21.4°C

Probe: EX3DV4 - SN3550; ConvF(7.21, 7.21, 7.21); Calibrated: 2/14/2011  
Sensor-Surface: 4mm (Mechanical Surface Detection)  
Electronics: DAE4 Sn859; Calibrated: 7/8/2010  
Phantom: SAM Sub; Type: SAM 4.0; Serial: TP-1357

Measurement SW: DASY4, V4.7 Build 80; Postprocessing SW: SEMCAD, V1.8 Build 186

**Mode: WCDMA 1700, Body SAR, Right Edge, Mid.ch**

**Area Scan (5x13x1):** Measurement grid: dx=15mm, dy=15mm

**Zoom Scan (5x5x7)/Cube 0:** Measurement grid: dx=8mm, dy=8mm, dz=5mm

Reference Value = 9.91 V/m

Peak SAR (extrapolated) = 0.234 W/kg

**SAR(1 g) = 0.145 mW/g; SAR(10 g) = 0.086 mW/g**

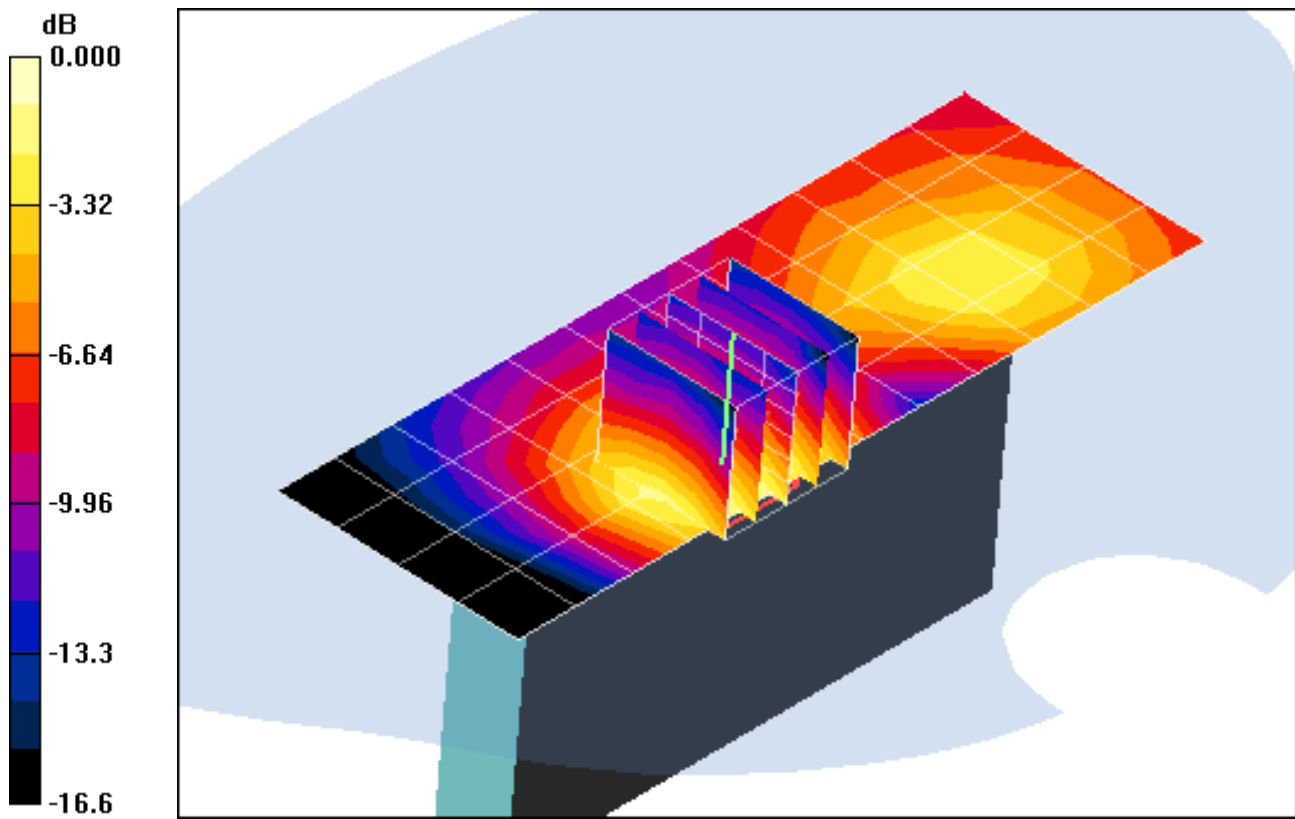

0 dB = 0.157mW/g

# PCTEST ENGINEERING LABORATORY, INC.

**DUT: A3LSGHT839; Type: 850/1900 GSM/GPRS/EDGE and 1700 WCDMA/HSPA Phone with Bluetooth and WLAN; Serial: FI-035-A**

Communication System: WCDMA1700; Frequency: 1730.4 MHz; Duty Cycle: 1:1  
Medium: 1750 Body Medium parameters used (interpolated):  
 $f = 1730.4 \text{ MHz}$ ;  $\sigma = 1.54 \text{ mho/m}$ ;  $\epsilon_r = 53.6$ ;  $\rho = 1000 \text{ kg/m}^3$   
Phantom section: Flat Section; Space: 1.0 cm

Test Date: 03-04-2011; Ambient Temp: 23.3 °C ; Tissue Temp: 21.4 °C

Probe: EX3DV4 - SN3550; ConvF(7.21, 7.21, 7.21); Calibrated: 2/14/2011  
Sensor-Surface: 4mm (Mechanical Surface Detection)  
Electronics: DAE4 Sn859; Calibrated: 7/8/2010  
Phantom: SAM Sub; Type: SAM 4.0; Serial: TP-1357

Measurement SW: DASY4, V4.7 Build 80; Postprocessing SW: SEMCAD, V1.8 Build 186

**Mode: WCDMA 1700, Body SAR, Left Edge, Mid.ch**

**Area Scan (5x13x1):** Measurement grid: dx=15mm, dy=15mm

**Zoom Scan (5x5x7)/Cube 0:** Measurement grid: dx=8mm, dy=8mm, dz=5mm

Reference Value = 11.4 V/m

Peak SAR (extrapolated) = 0.323 W/kg

**SAR(1 g) = 0.197 mW/g; SAR(10 g) = 0.116 mW/g**

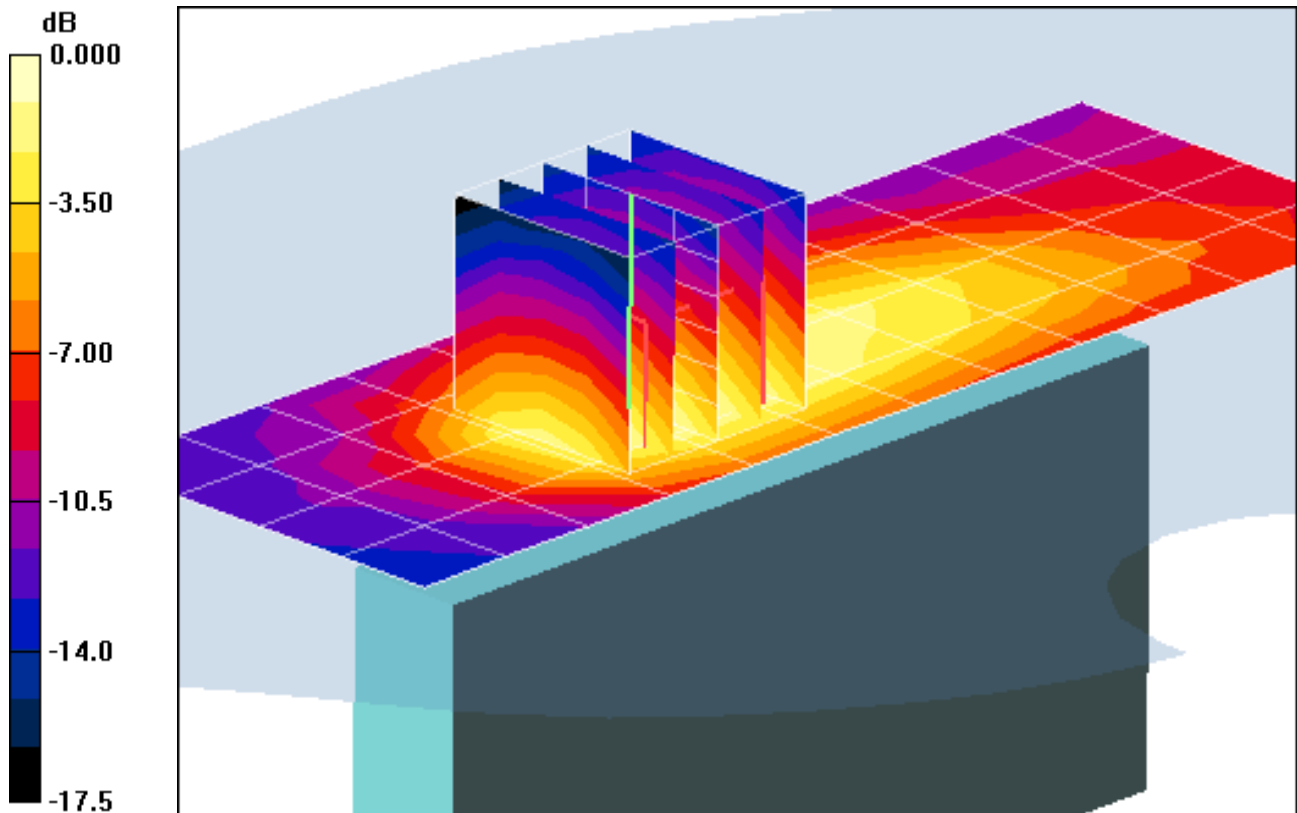

0 dB = 0.217mW/g

# PCTEST ENGINEERING LABORATORY, INC.

**DUT: A3LSGHT839; Type: 850/1900 GSM/GPRS/EDGE and 1700 WCDMA/HSPA Phone with Bluetooth and WLAN; Serial: FI-035-A**

Communication System: IEEE 802.11b; Frequency: 2462 MHz; Duty Cycle: 1:1  
Medium: 2450 Body Medium parameters used (interpolated):  
 $f = 2462 \text{ MHz}$ ;  $\sigma = 1.9 \text{ mho/m}$ ;  $\epsilon_r = 51.1$ ;  $\rho = 1000 \text{ kg/m}^3$   
Phantom section: Flat Section; Space: 1.0 cm

Test Date: 03-01-2011; Ambient Temp: 24.8 °C ; Tissue Temp: 23.5 °C

Probe: EX3DV4 - SN3550; ConvF(6.25, 6.25, 6.25); Calibrated: 2/14/2011  
Sensor-Surface: 3mm (Mechanical Surface Detection)  
Electronics: DAE4 Sn859; Calibrated: 7/8/2010  
Phantom: SAM Sub; Type: SAM 4.0; Serial: TP-1357

Measurement SW: DASY4, V4.7 Build 80; Postprocessing SW: SEMCAD, V1.8 Build 186

**Mode: IEEE 802.11b, Body SAR, Ch.11, 1Mbps, Back Side**

**Area Scan (7x11x1):** Measurement grid: dx=15mm, dy=15mm

**Zoom Scan (5x5x7)/Cube 0:** Measurement grid: dx=8mm, dy=8mm, dz=5mm

Reference Value = 17.8 V/m

Peak SAR (extrapolated) = 1.05 W/kg

**SAR(1 g) = 0.542 mW/g; SAR(10 g) = 0.285 mW/g**

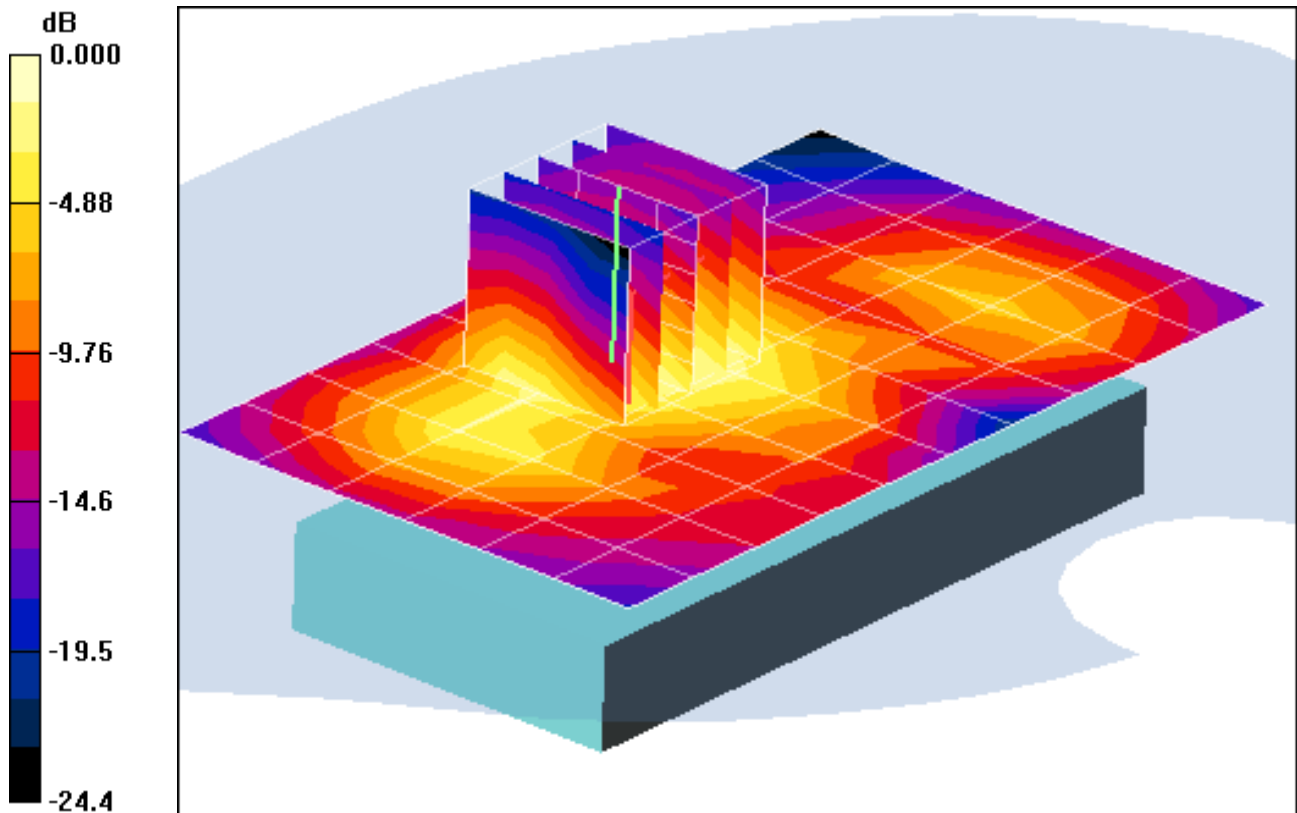

0 dB = 0.672mW/g

# PCTEST ENGINEERING LABORATORY, INC.

**DUT: A3LSGHT839; Type: 850/1900 GSM/GPRS/EDGE and 1700 WCDMA/HSPA Phone with Bluetooth and WLAN; Serial: FI-035-A**

Communication System: IEEE 802.11b; Frequency: 2462 MHz; Duty Cycle: 1:1  
Medium: 2450 Body Medium parameters used (interpolated):  
 $f = 2462 \text{ MHz}$ ;  $\sigma = 1.9 \text{ mho/m}$ ;  $\epsilon_r = 51.1$ ;  $\rho = 1000 \text{ kg/m}^3$   
Phantom section: Flat Section; Space: 1.0 cm

Test Date: 03-01-2011; Ambient Temp: 24.8 °C ; Tissue Temp: 23.5 °C

Probe: EX3DV4 - SN3550; ConvF(6.25, 6.25, 6.25); Calibrated: 2/14/2011  
Sensor-Surface: 3mm (Mechanical Surface Detection)  
Electronics: DAE4 Sn859; Calibrated: 7/8/2010  
Phantom: SAM Sub; Type: SAM 4.0; Serial: TP-1357

Measurement SW: DASY4, V4.7 Build 80; Postprocessing SW: SEMCAD, V1.8 Build 186

**Mode: IEEE 802.11b, Body SAR, Ch.11, 1Mbps, Back Side**

**Area Scan (7x11x1):** Measurement grid: dx=15mm, dy=15mm

**Zoom Scan (5x5x7)/Cube 0:** Measurement grid: dx=8mm, dy=8mm, dz=5mm

Reference Value = 17.8 V/m

Peak SAR (extrapolated) = 1.05 W/kg

**SAR(1 g) = 0.542 mW/g; SAR(10 g) = 0.285 mW/g**

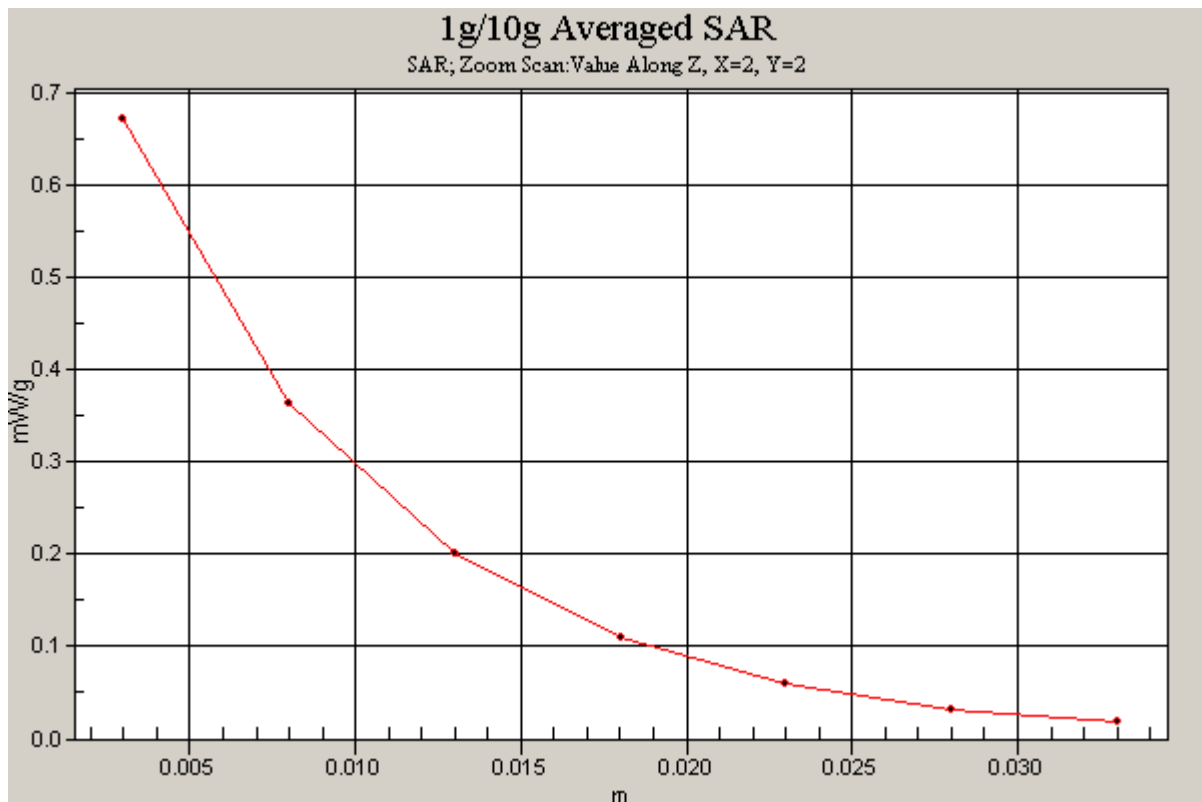

# PCTEST ENGINEERING LABORATORY, INC.

**DUT: A3LSGHT839; Type: 850/1900 GSM/GPRS/EDGE and 1700 WCDMA/HSPA Phone with Bluetooth and WLAN; Serial: FI-035-A**

Communication System: IEEE 802.11b; Frequency: 2462 MHz; Duty Cycle: 1:1  
Medium: 2450 Body Medium parameters used (interpolated):  
 $f = 2462 \text{ MHz}$ ;  $\sigma = 1.9 \text{ mho/m}$ ;  $\epsilon_r = 51.1$ ;  $\rho = 1000 \text{ kg/m}^3$   
Phantom section: Flat Section; Space: 1.0 cm

Test Date: 03-01-2011; Ambient Temp: 24.8 °C ; Tissue Temp: 23.5 °C

Probe: EX3DV4 - SN3550; ConvF(6.25, 6.25, 6.25); Calibrated: 2/14/2011  
Sensor-Surface: 3mm (Mechanical Surface Detection)  
Electronics: DAE4 Sn859; Calibrated: 7/8/2010  
Phantom: SAM Sub; Type: SAM 4.0; Serial: TP-1357

Measurement SW: DASY4, V4.7 Build 80; Postprocessing SW: SEMCAD, V1.8 Build 186

**Mode: IEEE 802.11b, Body SAR, Ch.11, 1Mbps, Front Side**

**Area Scan (7x11x1):** Measurement grid: dx=15mm, dy=15mm

**Zoom Scan (5x5x7)/Cube 0:** Measurement grid: dx=8mm, dy=8mm, dz=5mm

Reference Value = 5.25 V/m

Peak SAR (extrapolated) = 0.089 W/kg

**SAR(1 g) = 0.048 mW/g; SAR(10 g) = 0.026 mW/g**

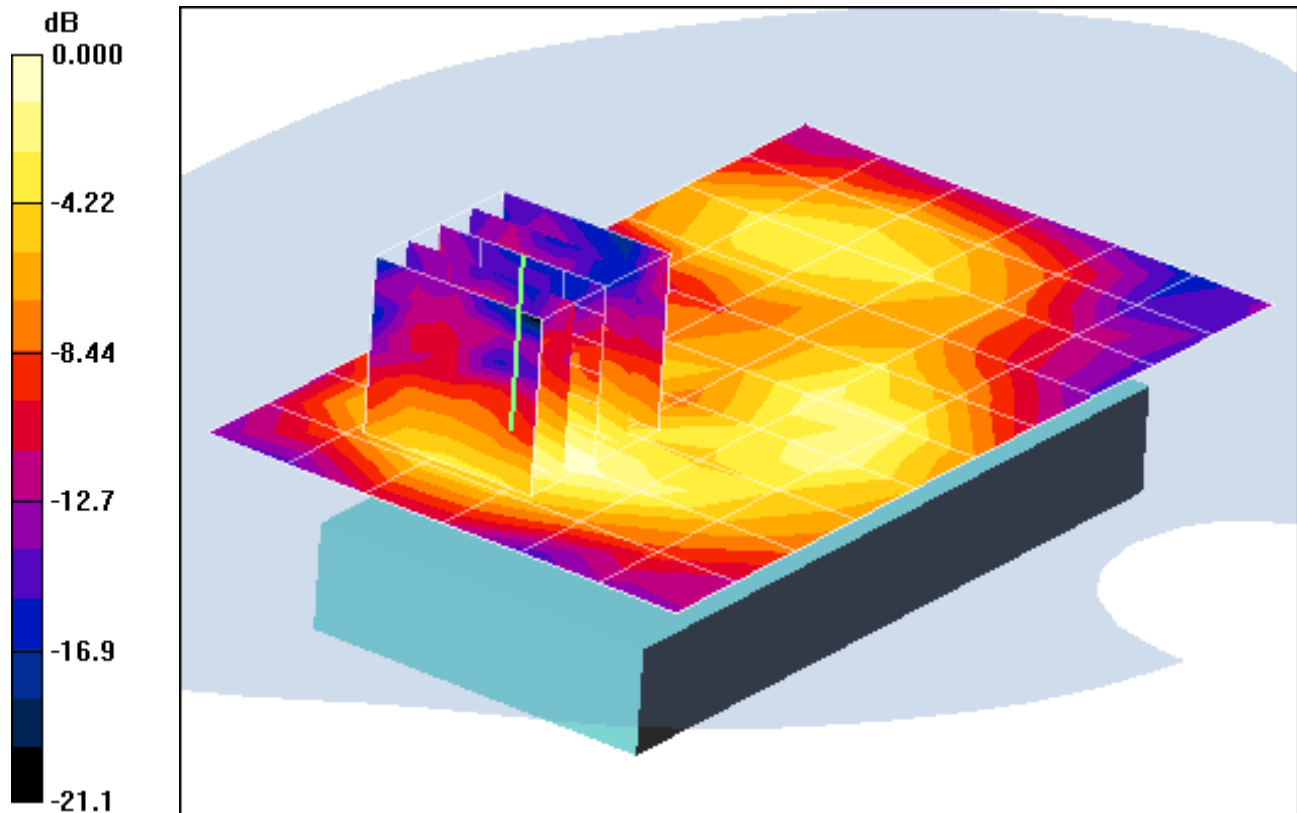

0 dB = 0.059mW/g

# PCTEST ENGINEERING LABORATORY, INC.

**DUT: A3LSGHT839; Type: 850/1900 GSM/GPRS/EDGE and 1700 WCDMA/HSPA Phone with Bluetooth and WLAN; Serial: FI-035-A**

Communication System: IEEE 802.11b; Frequency: 2462 MHz; Duty Cycle: 1:1  
Medium: 2450 Body Medium parameters used (interpolated):  
 $f = 2462 \text{ MHz}$ ;  $\sigma = 1.9 \text{ mho/m}$ ;  $\epsilon_r = 51.1$ ;  $\rho = 1000 \text{ kg/m}^3$   
Phantom section: Flat Section; Space: 1.0 cm

Test Date: 03-01-2011; Ambient Temp: 24.8 °C ; Tissue Temp: 23.5 °C

Probe: EX3DV4 - SN3550; ConvF(6.25, 6.25, 6.25); Calibrated: 2/14/2011  
Sensor-Surface: 3mm (Mechanical Surface Detection)  
Electronics: DAE4 Sn859; Calibrated: 7/8/2010  
Phantom: SAM Sub; Type: SAM 4.0; Serial: TP-1357

Measurement SW: DASY4, V4.7 Build 80; Postprocessing SW: SEMCAD, V1.8 Build 186

**Mode: IEEE 802.11b, Body SAR, Ch.11, 1Mbps, Bottom Edge**

**Area Scan (6x8x1):** Measurement grid: dx=15mm, dy=15mm

**Zoom Scan (5x5x7)/Cube 0:** Measurement grid: dx=8mm, dy=8mm, dz=5mm

Reference Value = 3.29 V/m

Peak SAR (extrapolated) = 0.037 W/kg

**SAR(1 g) = 0.019 mW/g; SAR(10 g) = 0.00999 mW/g**

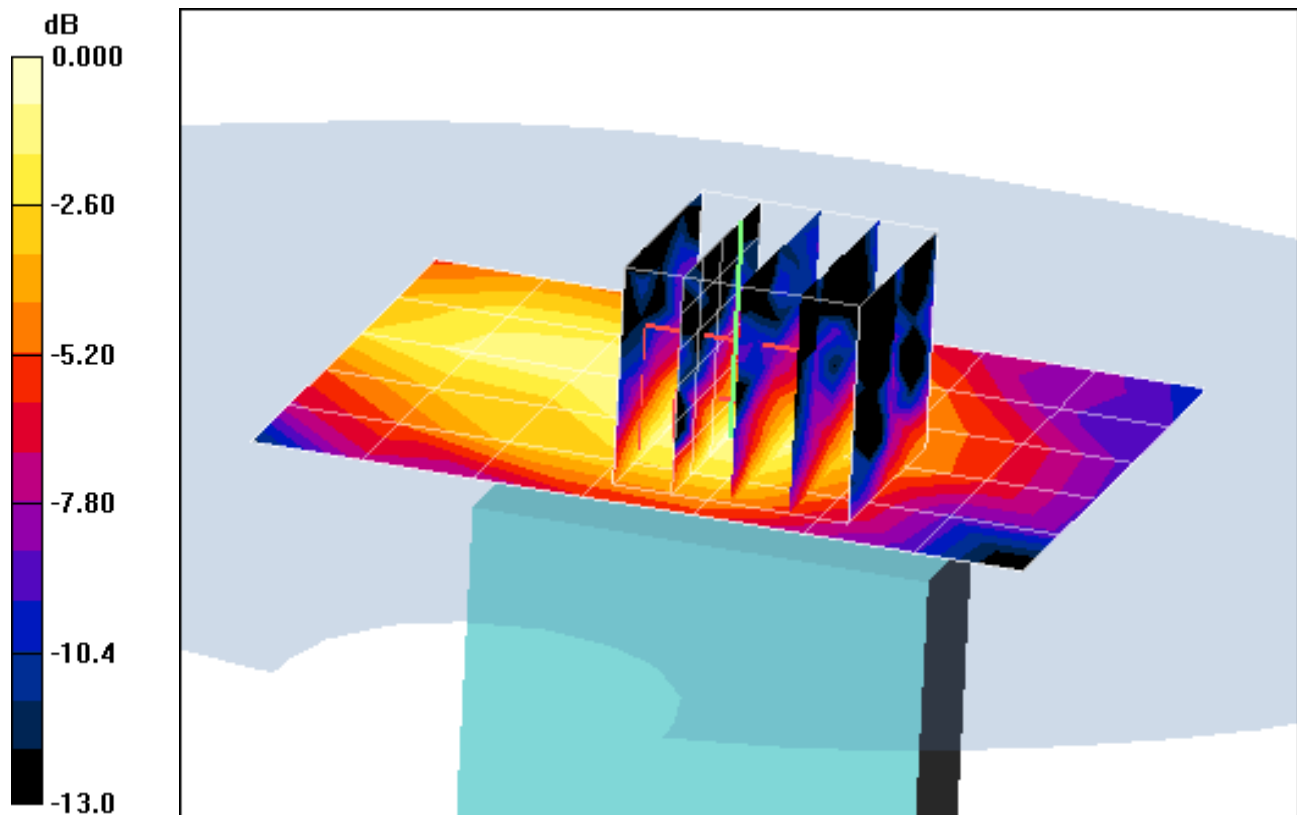

0 dB = 0.025mW/g

# PCTEST ENGINEERING LABORATORY, INC.

**DUT: A3LSGHT839; Type: 850/1900 GSM/GPRS/EDGE and 1700 WCDMA/HSPA Phone with Bluetooth and WLAN; Serial: FI-035-A**

Communication System: IEEE 802.11b; Frequency: 2462 MHz; Duty Cycle: 1:1  
Medium: 2450 Body Medium parameters used (interpolated):  
 $f = 2462 \text{ MHz}$ ;  $\sigma = 1.9 \text{ mho/m}$ ;  $\epsilon_r = 51.1$ ;  $\rho = 1000 \text{ kg/m}^3$   
Phantom section: Flat Section; Space: 1.0 cm

Test Date: 03-01-2011; Ambient Temp: 24.8 °C ; Tissue Temp: 23.5 °C

Probe: EX3DV4 - SN3550; ConvF(6.25, 6.25, 6.25); Calibrated: 2/14/2011  
Sensor-Surface: 3mm (Mechanical Surface Detection)  
Electronics: DAE4 Sn859; Calibrated: 7/8/2010  
Phantom: SAM Sub; Type: SAM 4.0; Serial: TP-1357

Measurement SW: DASY4, V4.7 Build 80; Postprocessing SW: SEMCAD, V1.8 Build 186

**Mode: IEEE 802.11b, Body SAR, Ch.11, 1Mbps, Right Edge**

**Area Scan (6x12x1):** Measurement grid: dx=15mm, dy=15mm

**Zoom Scan (5x5x7)/Cube 0:** Measurement grid: dx=8mm, dy=8mm, dz=5mm

Reference Value = 8.04 V/m

Peak SAR (extrapolated) = 0.311 W/kg

**SAR(1 g) = 0.156 mW/g; SAR(10 g) = 0.076 mW/g**

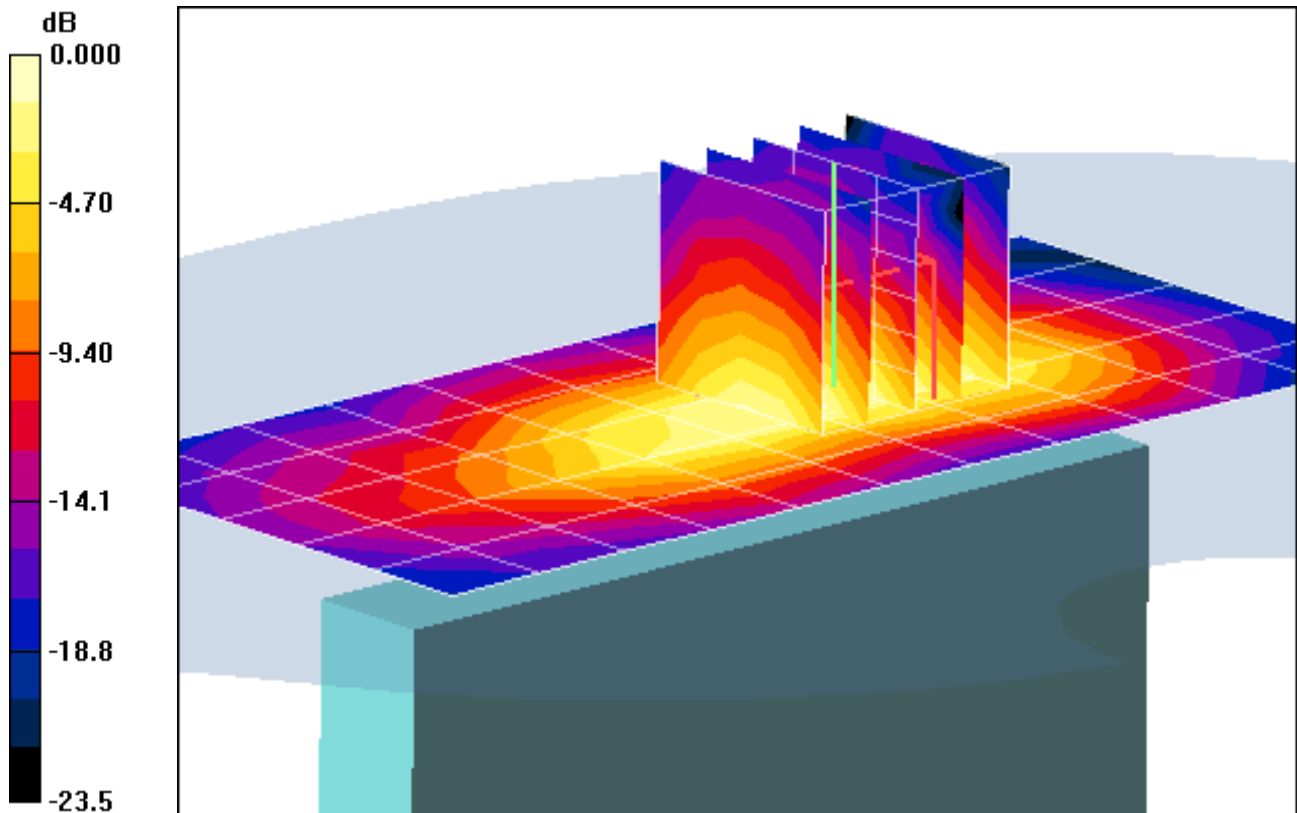

0 dB = 0.207mW/g

# PCTEST ENGINEERING LABORATORY, INC.

**DUT: A3LSGHT839; Type: 850/1900 GSM/GPRS/EDGE and 1700 WCDMA/HSPA Phone with Bluetooth and WLAN; Serial: FI-035-A**

Communication System: Bluetooth; Frequency: 2441 MHz; Duty Cycle: 1:1

Medium: 2450 Body Medium parameters used (interpolated):

$f = 2441 \text{ MHz}$ ;  $\sigma = 2.02 \text{ mho/m}$ ;  $\epsilon_r = 50.8$ ;  $\rho = 1000 \text{ kg/m}^3$

Phantom section: Flat Section; Space: 1.0 cm

Test Date: 03-09-2011; Ambient Temp: 23.8 °C; Tissue Temp: 22.4 °C

Probe: ES3DV3 - SN3209; ConvF(4.35, 4.35, 4.35); Calibrated: 4/20/2010

Sensor-Surface: 3mm (Mechanical Surface Detection)

Electronics: DAE4 Sn665; Calibrated: 4/21/2010

Phantom: SAM with CRP; Type: SAM; Serial: TP1375

Measurement SW: DASY4, V4.7 Build 80; Postprocessing SW: SEMCAD, V1.8 Build 186

**Mode: Bluetooth, Body SAR, Back Side, Mid. Ch**

**Area Scan (7x11x1):** Measurement grid: dx=15mm, dy=15mm

**Zoom Scan (5x5x7)/Cube 0:** Measurement grid: dx=8mm, dy=8mm, dz=5mm

Reference Value = 3.43 V/m

Peak SAR (extrapolated) = 0.048 W/kg

**SAR(1 g) = 0.024 mW/g; SAR(10 g) = 0.012 mW/g**

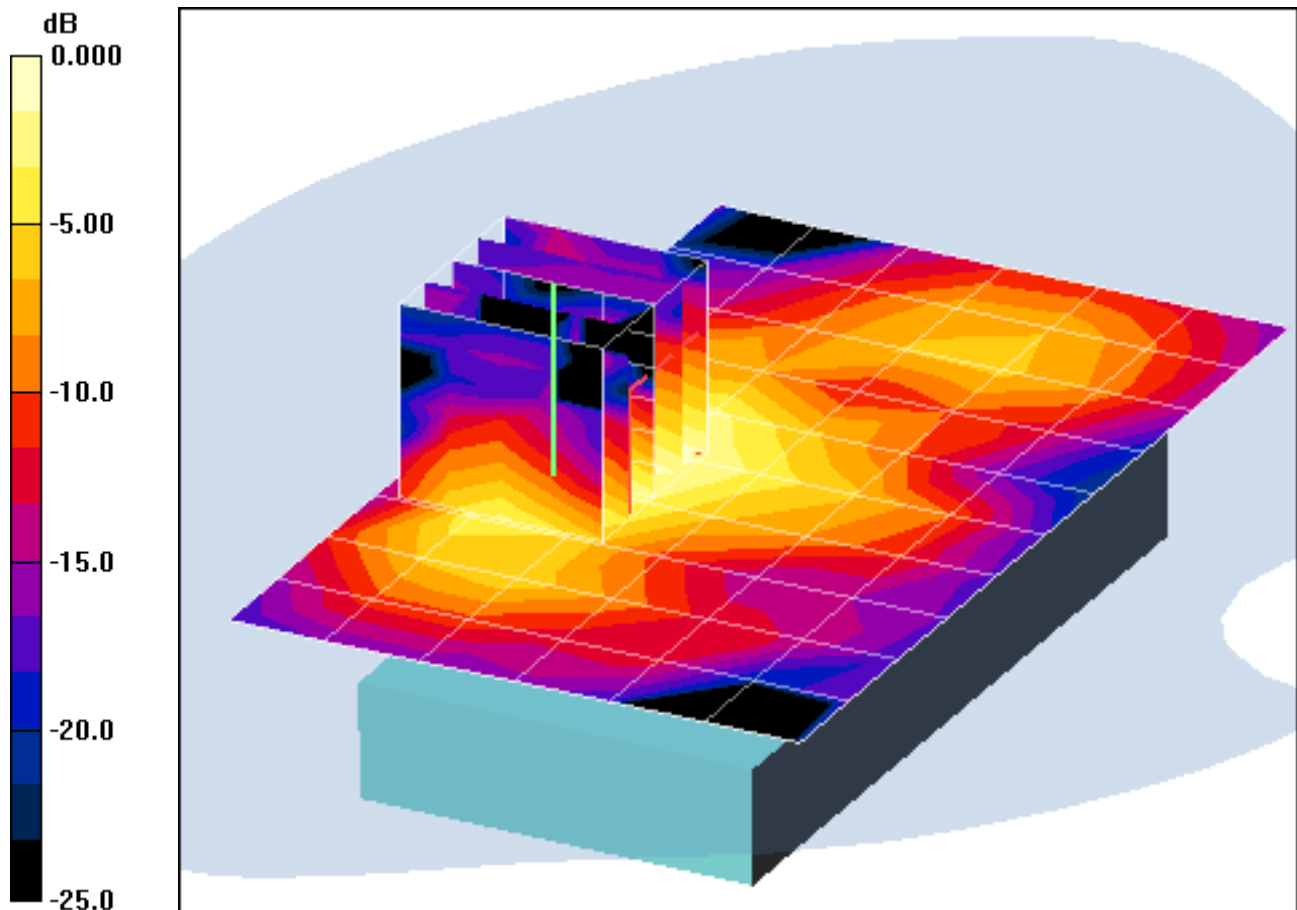

0 dB = 0.031mW/g

## **APPENDIX B: DIPOLE VALIDATION**

# PCTEST ENGINEERING LABORATORY, INC.

**DUT: Dipole 835 MHz; Type: D835V2; Serial: 4d026**

Communication System: CW; Frequency: 835 MHz; Duty Cycle: 1:1

Medium: 835 Head Medium parameters used:

$f = 835 \text{ MHz}$ ;  $\sigma = 0.885 \text{ mho/m}$ ;  $\epsilon_r = 42.7$ ;  $\rho = 1000 \text{ kg/m}^3$

Phantom section: Flat Section; Space: 1.5 cm

Test Date: 02-28-2011; Ambient Temp: 23.8 °C; Tissue Temp: 21.9 °C

Probe: ES3DV2 - SN3022; ConvF(6.02, 6.02, 6.02); Calibrated: 9/21/2010

Sensor-Surface: 4mm (Mechanical Surface Detection)

Electronics: DAE4 Sn704; Calibrated: 3/22/2010

Phantom: SAM Main; Type: SAM 4.0; Serial: TP-1114

Measurement SW: DASY4, V4.7 Build 80; Postprocessing SW: SEMCAD, V1.8 Build 186

## 835MHz System Verification

**Area Scan (7x13x1):** Measurement grid: dx=15mm, dy=15mm

**Zoom Scan (5x5x7)/Cube 0:** Measurement grid: dx=8mm, dy=8mm, dz=5mm

Input Power = 18.0 dBm (63 mW)

**SAR(1 g) = 0.580 mW/g; SAR(10 g) = 0.378 mW/g**

Deviation = -2.68 %

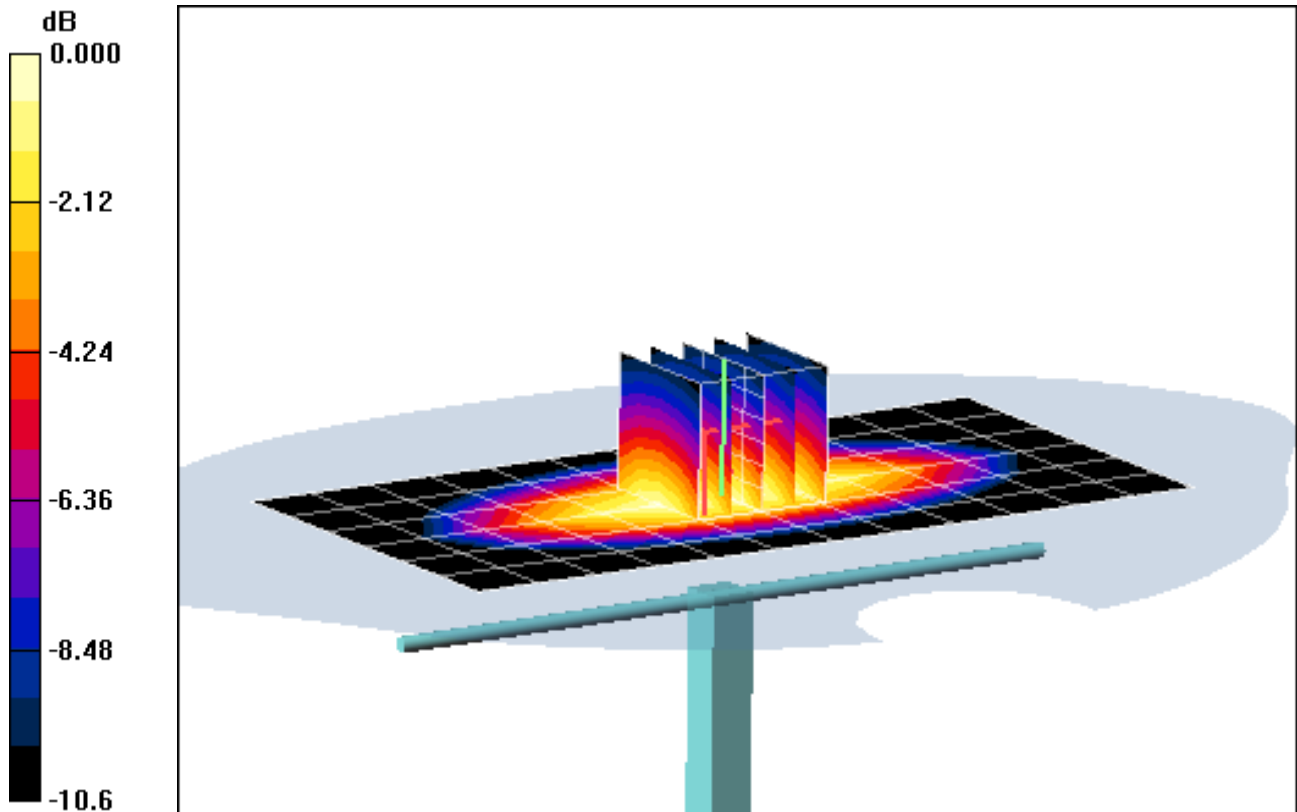

0 dB = 0.625mW/g

# PCTEST ENGINEERING LABORATORY, INC.

**DUT: Dipole 835 MHz; Type: D835V2; Serial: 4d026**

Communication System: CW; Frequency: 835 MHz; Duty Cycle: 1:1

Medium: 835 Body Medium parameters used:

$f = 835 \text{ MHz}$ ;  $\sigma = 0.959 \text{ mho/m}$ ;  $\epsilon_r = 52.9$ ;  $\rho = 1000 \text{ kg/m}^3$

Phantom section: Flat Section; Space: 1.5 cm

Test Date: 02-28-2011; Ambient Temp: 23.7 °C; Tissue Temp: 22.0 °C

Probe: ES3DV2 - SN3022; ConvF(5.89, 5.89, 5.89); Calibrated: 9/21/2010

Sensor-Surface: 4mm (Mechanical Surface Detection)

Electronics: DAE4 Sn704; Calibrated: 3/22/2010

Phantom: SAM Sub; Type: SAM 4.0; Serial: TP-1357

Measurement SW: DASY4, V4.7 Build 80; Postprocessing SW: SEMCAD, V1.8 Build 186

## 835MHz System Verification

**Area Scan (7x13x1):** Measurement grid: dx=15mm, dy=15mm

**Zoom Scan (5x5x7)/Cube 0:** Measurement grid: dx=8mm, dy=8mm, dz=5mm

Input Power = 18.0 dBm (63 mW)

**SAR(1 g) = 0.616 mW/g; SAR(10 g) = 0.405 mW/g**

Deviation = -0.02 %

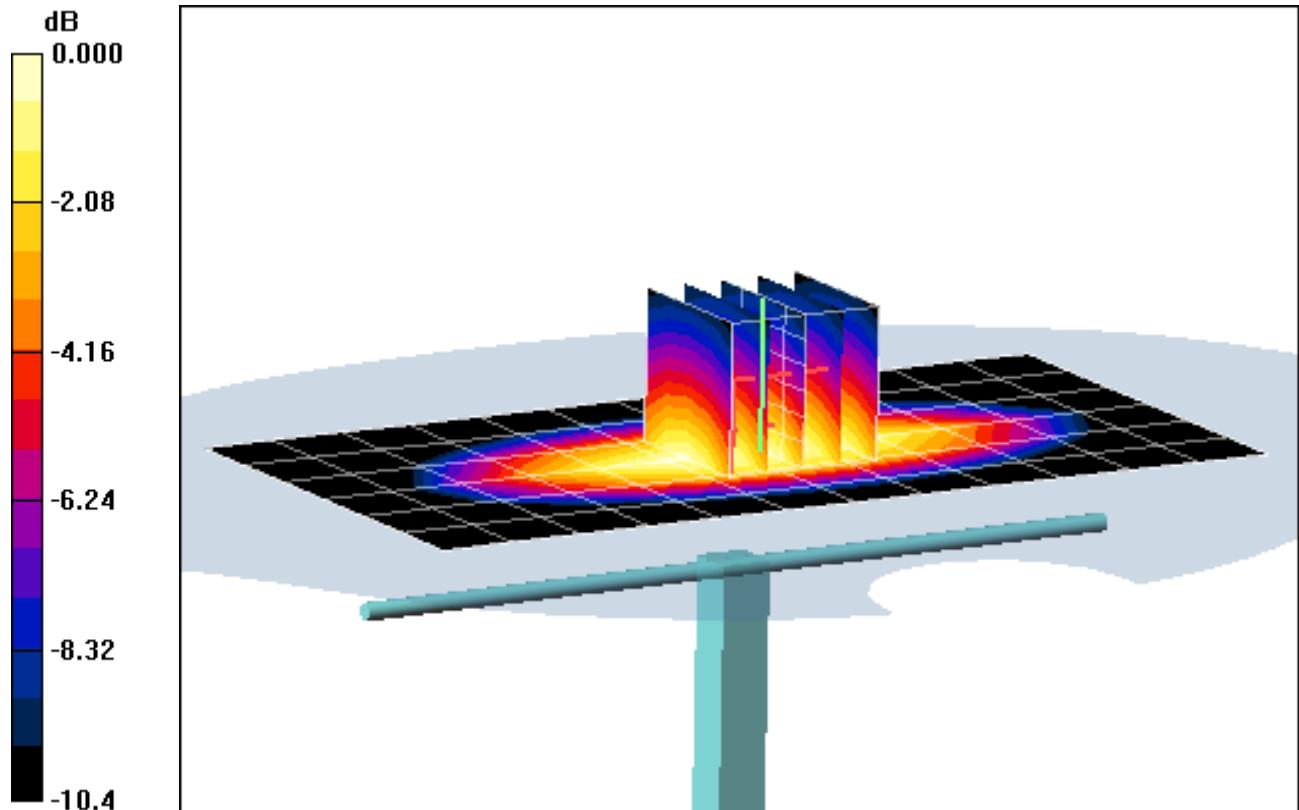

0 dB = 0.663mW/g

# PCTEST ENGINEERING LABORATORY, INC.

**DUT: Dipole 1765 MHz; Type: D1765V2; Serial: 1008**

Communication System: CW; Frequency: 1765 MHz; Duty Cycle: 1:1

Medium: 1750 Head Medium parameters used (interpolated):

$f = 1765 \text{ MHz}$ ;  $\sigma = 1.4 \text{ mho/m}$ ;  $\epsilon_r = 40.5$ ;  $\rho = 1000 \text{ kg/m}^3$

Phantom section: Flat Section; Space: 1.0 cm

Test Date: 03-04-2011; Ambient Temp: 23.3 ° C; Tissue Temp: 21.4 ° C

Probe: EX3DV4 - SN3550; ConvF(7.33, 7.33, 7.33); Calibrated: 2/14/2011

Sensor-Surface: 4mm (Mechanical Surface Detection)

Electronics: DAE4 Sn859; Calibrated: 7/8/2010

Phantom: SAM Main; Type: SAM 4.0; Serial: TP-1114

Measurement SW: DASY4, V4.7 Build 80; Postprocessing SW: SEMCAD, V1.8 Build 186

## 1765 MHz System Verification

**Area Scan (5x7x1):** Measurement grid: dx=15mm, dy=15mm

**Zoom Scan (5x5x7)/Cube 0:** Measurement grid: dx=8mm, dy=8mm, dz=5mm

Input Power = 16.0 dBm (40 mW)

**SAR(1 g) = 1.47 mW/g; SAR(10 g) = 0.750 mW/g**

Deviation = - 3.80 %

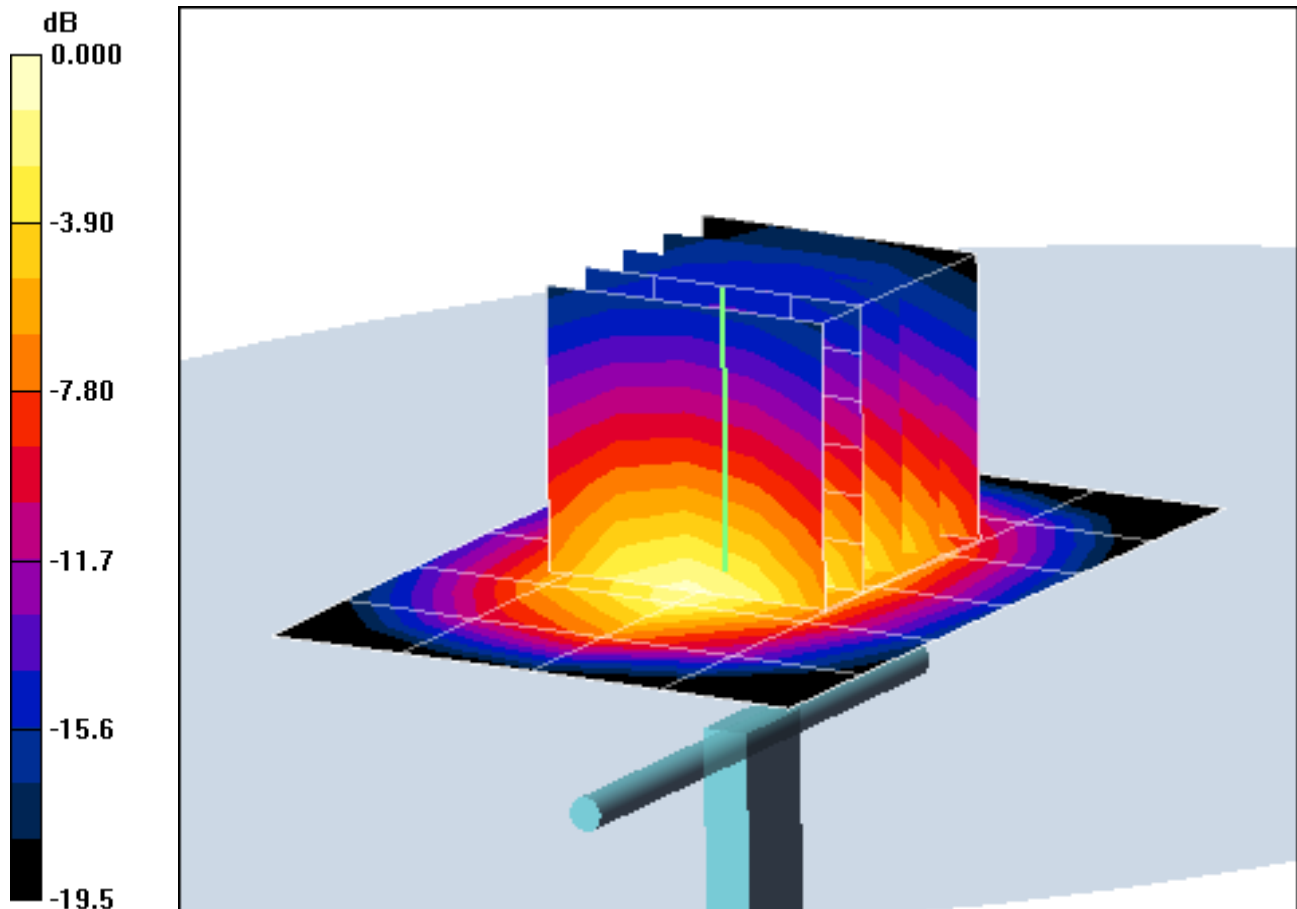

0 dB = 1.63mW/g

# PCTEST ENGINEERING LABORATORY, INC.

**DUT: Dipole 1765 MHz; Type: D1765V2; Serial: 1008**

Communication System: CW; Frequency: 1765 MHz; Duty Cycle: 1:1

Medium: 1750 Body Medium parameters used (interpolated):

$f = 1765 \text{ MHz}$ ;  $\sigma = 1.56 \text{ mho/m}$ ;  $\epsilon_r = 53.5$ ;  $\rho = 1000 \text{ kg/m}^3$

Phantom section: Flat Section; Space: 1.0 cm

Test Date: 03-04-2011; Ambient Temp: 23.3°C; Tissue Temp: 21.4°C

Probe: EX3DV4 - SN3550; ConvF(7.21, 7.21, 7.21); Calibrated: 2/14/2011

Sensor-Surface: 4mm (Mechanical Surface Detection)

Electronics: DAE4 Sn859; Calibrated: 7/8/2010

Phantom: SAM Sub; Type: SAM 4.0; Serial: TP-1357

Measurement SW: DASY4, V4.7 Build 80; Postprocessing SW: SEMCAD, V1.8 Build 186

## 1765 MHz System Verification

**Area Scan (5x7x1):** Measurement grid: dx=15mm, dy=15mm

**Zoom Scan (5x5x7)/Cube 0:** Measurement grid: dx=8mm, dy=8mm, dz=5mm

Input Power = 16.0 dBm (40 mW)

**SAR(1 g) = 1.47 mW/g; SAR(10 g) = 0.758 mW/g**

Deviation = -1.47%

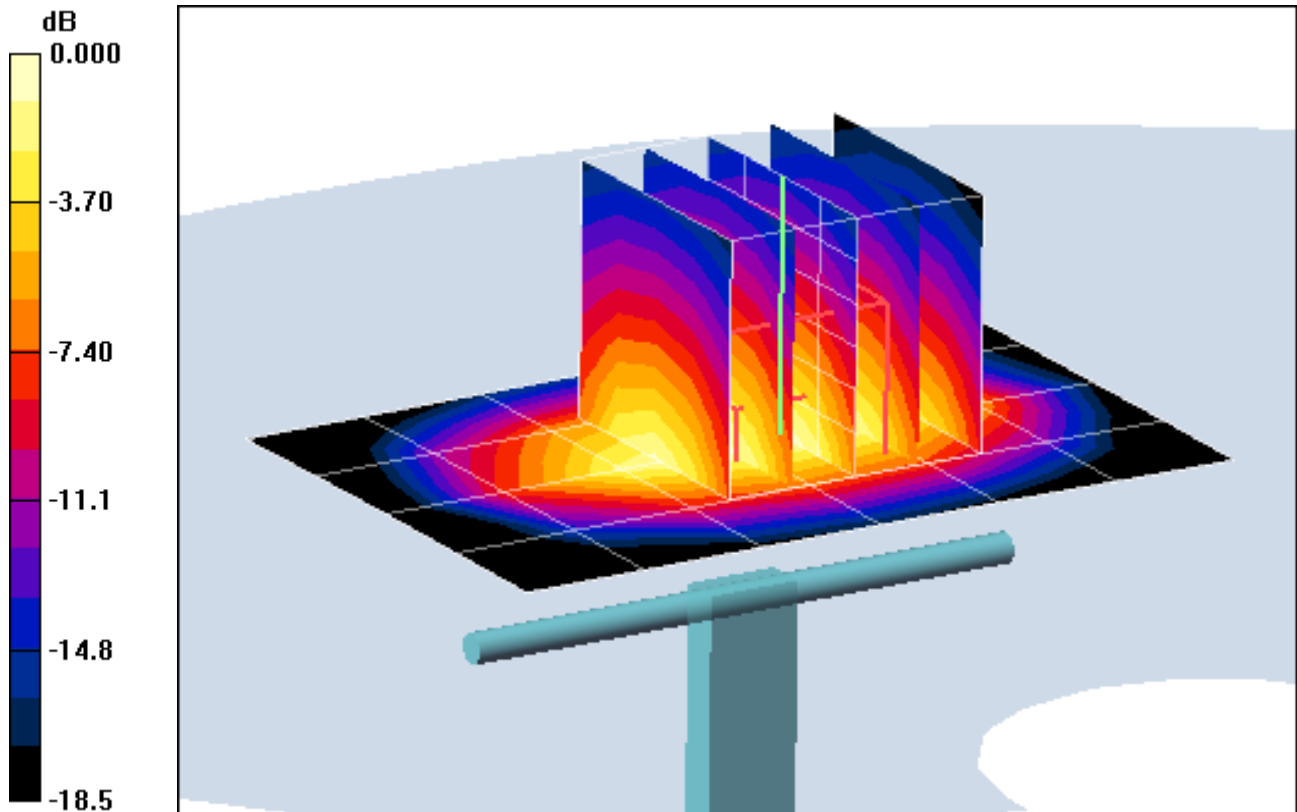

0 dB = 1.64mW/g

# PCTEST ENGINEERING LABORATORY, INC.

**DUT: SAR Dipole 1900 MHz; Type: D1900V2; Serial: 502**

Communication System: CW; Frequency: 1900 MHz; Duty Cycle: 1:1

Medium: 1900 Head Medium parameters used (interpolated):

$f = 1900 \text{ MHz}$ ;  $\sigma = 1.46 \text{ mho/m}$ ;  $\epsilon_r = 40.2$ ;  $\rho = 1000 \text{ kg/m}^3$

Phantom section: Flat Section; Space: 1.0 cm

Test Date: 03-02-2011; Ambient Temp: 24.2 °C; Tissue Temp: 22.5 °C

Probe: ES3DV2 - SN3022; ConvF(4.83, 4.83, 4.83); Calibrated: 9/21/2010

Sensor-Surface: 4mm (Mechanical Surface Detection)

Electronics: DAE4 Sn704; Calibrated: 3/22/2010

Phantom: SAM Main; Type: SAM 4.0; Serial: TP-1406

Measurement SW: DASY4, V4.7 Build 80; Postprocessing SW: SEMCAD, V1.8 Build 186

## 1900MHz System Verification

**Area Scan (5x7x1):** Measurement grid: dx=15mm, dy=15mm

**Zoom Scan (5x5x7)/Cube 0:** Measurement grid: dx=8mm, dy=8mm, dz=5mm

Input Power = 16.0 dBm (40 mW)

**SAR(1 g) = 1.59 mW/g; SAR(10 g) = 0.825 mW/g**

Deviation = -1.12 %

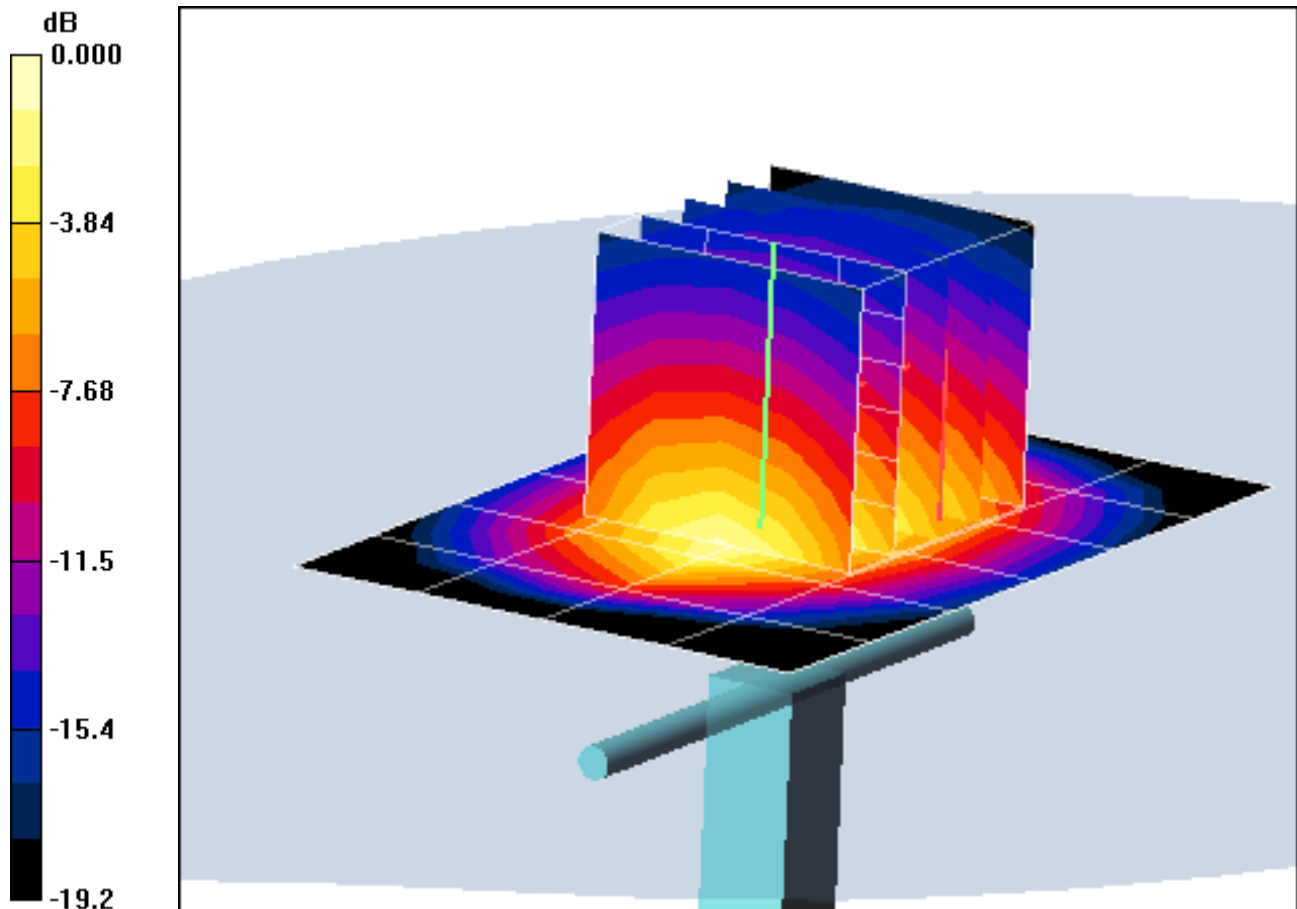

0 dB = 1.76mW/g

# PCTEST ENGINEERING LABORATORY, INC.

**DUT: SAR Dipole 1900 MHz; Type: D1900V2; Serial: 502**

Communication System: CW; Frequency: 1900 MHz; Duty Cycle: 1:1

Medium: 1900 Body Medium parameters used (interpolated):

$f = 1900 \text{ MHz}$ ;  $\sigma = 1.59 \text{ mho/m}$ ;  $\epsilon_r = 51.1$ ;  $\rho = 1000 \text{ kg/m}^3$

Phantom section: Flat Section; Space: 1.0 cm

Test Date: 02-28-2011; Ambient Temp: 24.6 °C; Tissue Temp: 22.8 °C

Probe: EX3DV4 - SN3561; ConvF(6.59, 6.59, 6.59); Calibrated: 8/19/2010

Sensor-Surface: 4mm (Mechanical Surface Detection)

Electronics: DAE4 Sn665; Calibrated: 4/21/2010

Phantom: SAM with CRP; Type: SAM; Serial: TP1375

Measurement SW: DASY4, V4.7 Build 80; Postprocessing SW: SEMCAD, V1.8 Build 186

## 1900MHz System Verification

**Area Scan (5x7x1):** Measurement grid: dx=15mm, dy=15mm

**Zoom Scan (5x5x7)/Cube 0:** Measurement grid: dx=8mm, dy=8mm, dz=5mm

Input Power = 20.0 dBm (100 mW)

**SAR(1 g) = 4.3 mW/g; SAR(10 g) = 2.21 mW/g**

Deviation = 4.62 %

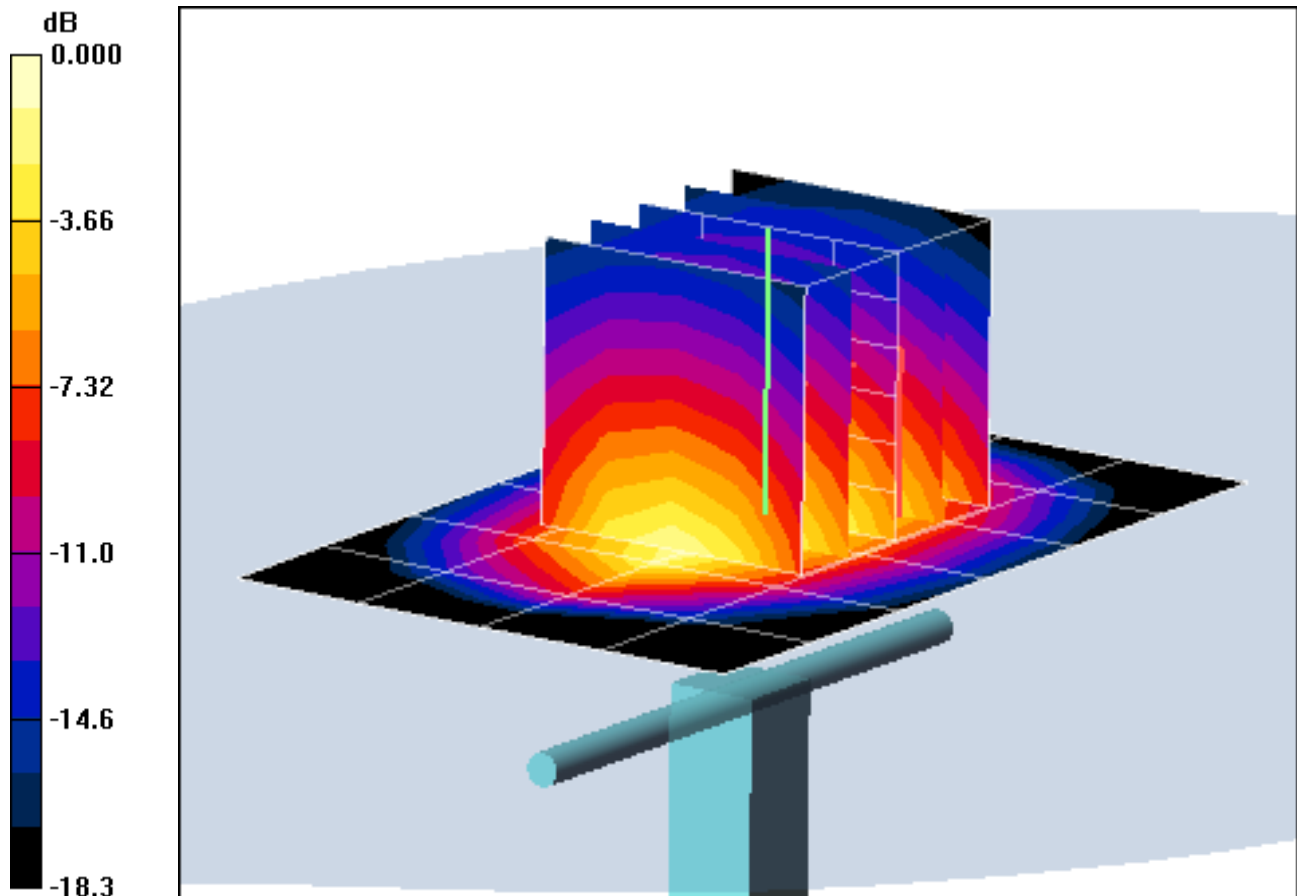

0 dB = 4.78mW/g

# PCTEST ENGINEERING LABORATORY, INC.

**DUT: SAR Dipole 2450 MHz; Type: D2450V2; Serial: 719**

Communication System: CW; Frequency: 2450 MHz; Duty Cycle: 1:1

Medium: 2450 Head Medium parameters used:

$f = 2450 \text{ MHz}$ ;  $\sigma = 1.83 \text{ mho/m}$ ;  $\epsilon_r = 38.1$ ;  $\rho = 1000 \text{ kg/m}^3$

Phantom section: Flat Section; Space: 1.0 cm

Test Date: 03-02-2011; Ambient Temp: 23.8 °C; Tissue Temp: 21.9 °C

Probe: EX3DV4 - SN3550; ConvF(6.29, 6.29, 6.29); Calibrated: 2/14/2011

Sensor-Surface: 3mm (Mechanical Surface Detection)

Electronics: DAE4 Sn859; Calibrated: 7/8/2010

Phantom: SAM Main; Type: SAM 4.0; Serial: TP-1114

Measurement SW: DASY4, V4.7 Build 80; Postprocessing SW: SEMCAD, V1.8 Build 186

## 2450MHz System Verification

**Area Scan (5x7x1):** Measurement grid: dx=15mm, dy=15mm

**Zoom Scan (5x5x7)/Cube 0:** Measurement grid: dx=8mm, dy=8mm, dz=5mm

Input Power = 14.0 dBm (25 mW)

**SAR(1 g) = 1.27 mW/g; SAR(10 g) = 0.572 mW/g**

Deviation = -5.05 %

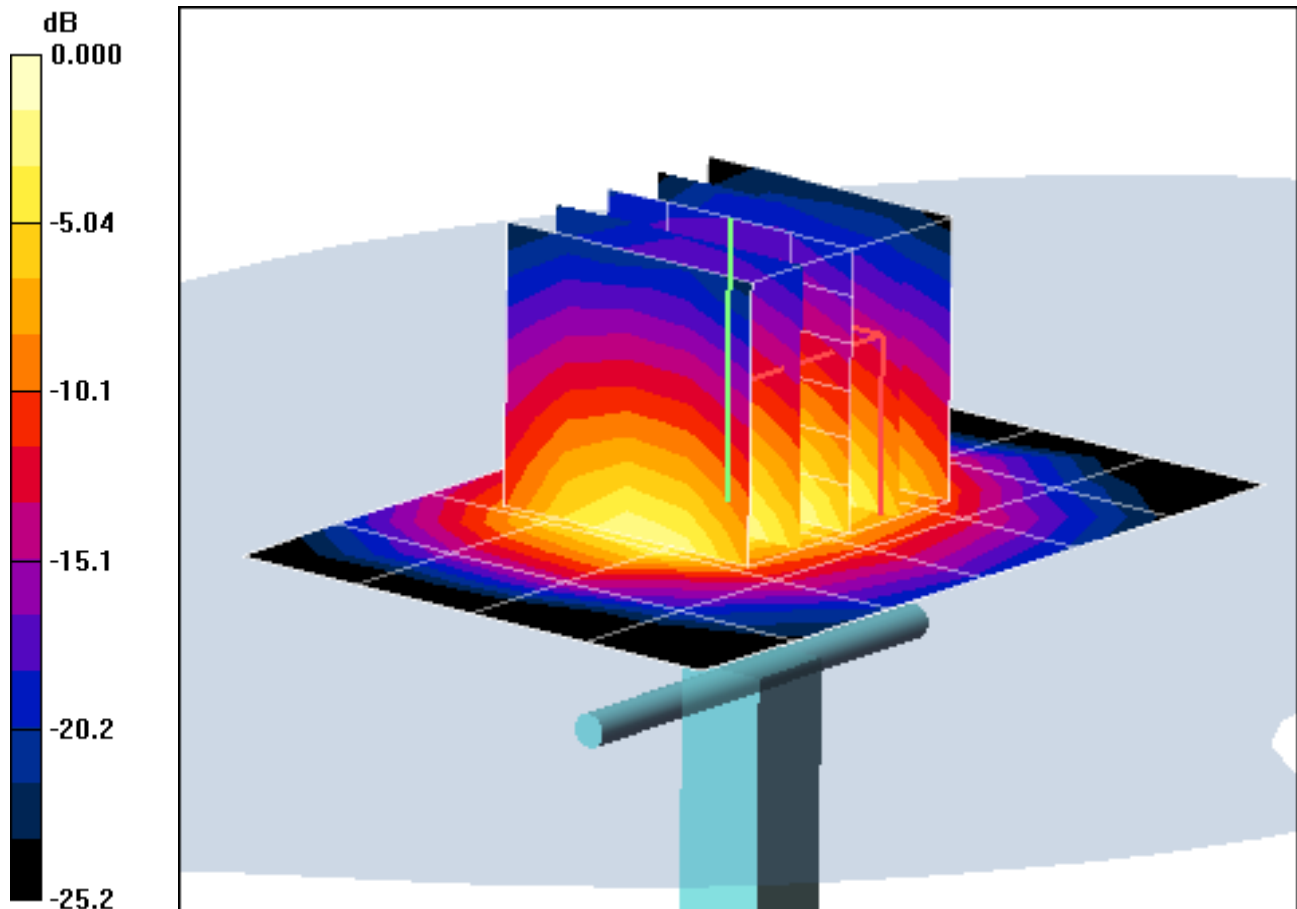

0 dB = 1.56mW/g

# PCTEST ENGINEERING LABORATORY, INC.

**DUT: SAR Dipole 2450 MHz; Type: D2450V2; Serial: 719**

Communication System: CW; Frequency: 2450 MHz; Duty Cycle: 1:1

Medium: 2450 Body Medium parameters used:

$f = 2450 \text{ MHz}$ ;  $\sigma = 1.88 \text{ mho/m}$ ;  $\epsilon_r = 51.1$ ;  $\rho = 1000 \text{ kg/m}^3$

Phantom section: Flat Section; Space: 1.0 cm

Test Date: 03-01-2011; Ambient Temp: 24.8 °C; Tissue Temp: 23.5 °C

Probe: EX3DV4 - SN3550; ConvF(6.25, 6.25, 6.25); Calibrated: 2/14/2011

Sensor-Surface: 3mm (Mechanical Surface Detection)

Electronics: DAE4 Sn859; Calibrated: 7/8/2010

Phantom: SAM Sub; Type: SAM 4.0; Serial: TP-1357

Measurement SW: DASY4, V4.7 Build 80; Postprocessing SW: SEMCAD, V1.8 Build 186

## 2450MHz System Verification

**Area Scan (5x7x1):** Measurement grid: dx=15mm, dy=15mm

**Zoom Scan (5x5x7)/Cube 0:** Measurement grid: dx=8mm, dy=8mm, dz=5mm

Input Power = 14.0 dBm (25 mW)

**SAR(1 g) = 1.35 mW/g; SAR(10 g) = 0.620 mW/g**

Deviation = 5.06 %

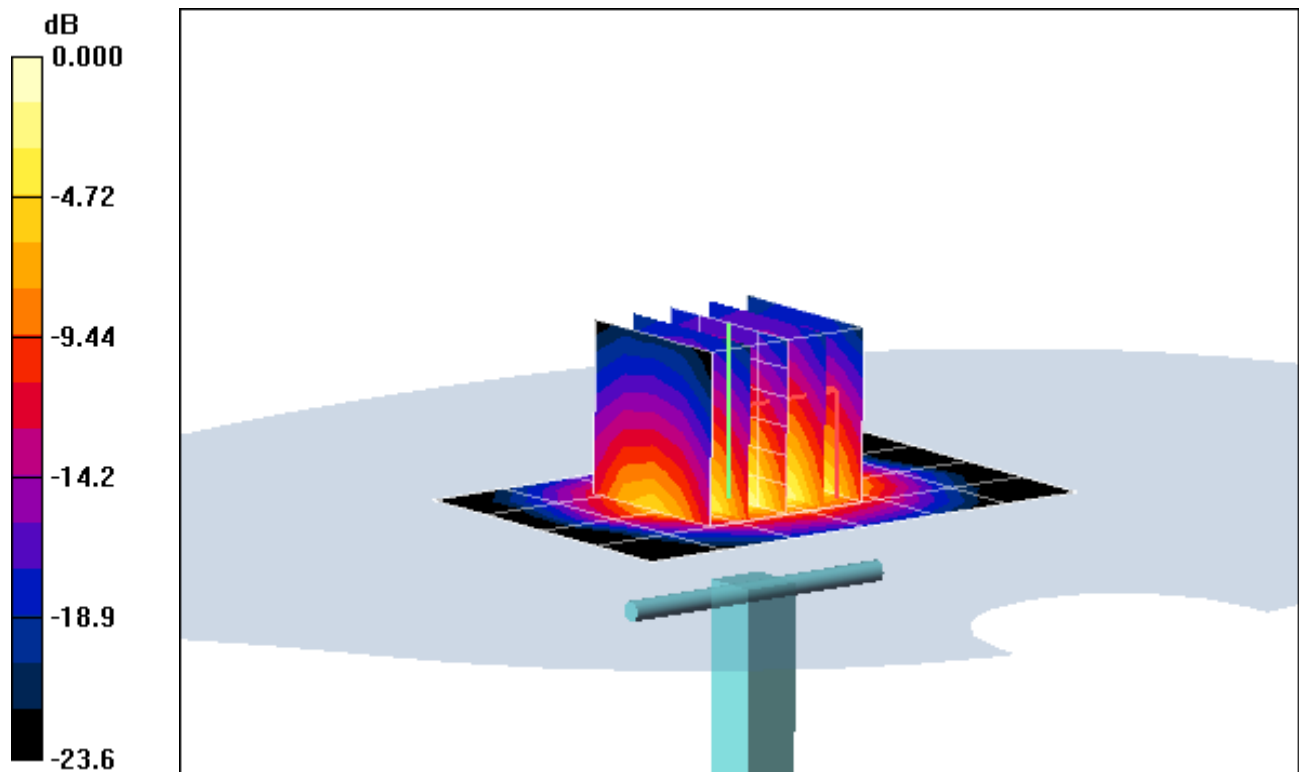

0 dB = 1.74mW/g

# PCTEST ENGINEERING LABORATORY, INC.

**DUT: SAR Dipole 2450 MHz; Type: D2450V2; Serial: 797**

Communication System: CW; Frequency: 2450 MHz; Duty Cycle: 1:1

Medium: 2450 Body Medium parameters used:

$f = 2450 \text{ MHz}$ ;  $\sigma = 2.03 \text{ mho/m}$ ;  $\epsilon_r = 50.8$ ;  $\rho = 1000 \text{ kg/m}^3$

Phantom section: Flat Section; Space: 1.0 cm

Test Date: 03-09-2011; Ambient Temp: 23.8°C; Tissue Temp: 22.4°C

Probe: ES3DV3 - SN3209; ConvF(4.35, 4.35, 4.35); Calibrated: 4/20/2010

Sensor-Surface: 3mm (Mechanical Surface Detection)

Electronics: DAE4 Sn665; Calibrated: 4/21/2010

Phantom: SAM with CRP; Type: SAM; Serial: TP1375

Measurement SW: DASY4, V4.7 Build 80; Postprocessing SW: SEMCAD, V1.8 Build 186

## 2450MHz System Verification

**Area Scan (5x7x1):** Measurement grid: dx=15mm, dy=15mm

**Zoom Scan (5x5x7)/Cube 0:** Measurement grid: dx=8mm, dy=8mm, dz=5mm

Input Power = 12.0 dBm (15.8 mW)

**SAR(1 g) = 0.841 mW/g; SAR(10 g) = 0.381 mW/g**

Deviation = 1.77 %

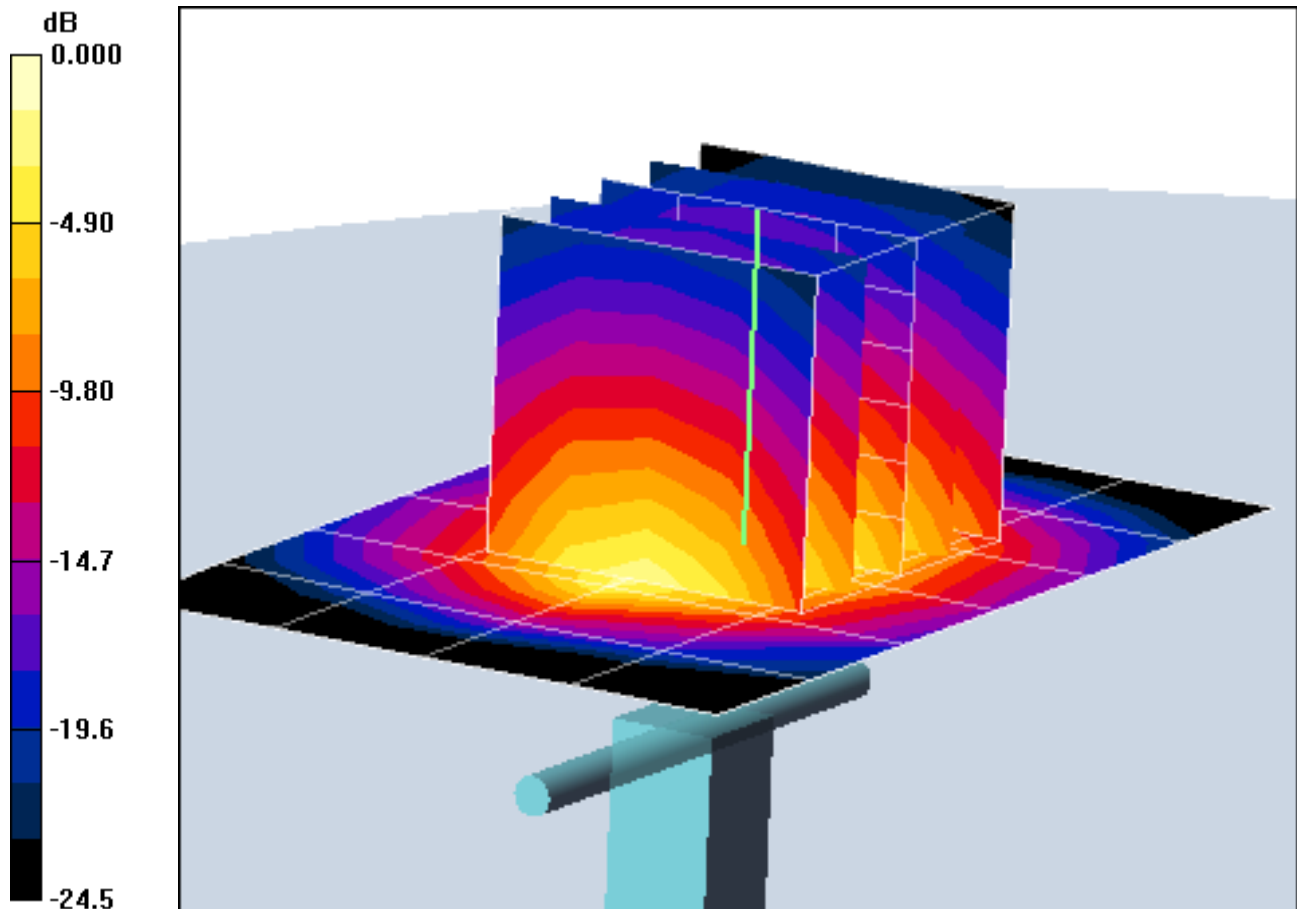

0 dB = 1.10mW/g

## **APPENDIX C: PROBE CALIBRATION**



Accredited by the Swiss Accreditation Service (SAS)  
The Swiss Accreditation Service is one of the signatories to the EA  
Multilateral Agreement for the recognition of calibration certificates

Accreditation No.: **SCS 108**

Client **PC Test**

Certificate No: **D835V2-4d026\_Aug09**

**CALIBRATION CERTIFICATE**

Object **D835V2 - SN: 4d026**

Calibration procedure(s) **QA CAL-05.v7  
Calibration procedure for dipole validation kits**

Calibration date: **August 24, 2009**

Condition of the calibrated item **In Tolerance**

This calibration certificate documents the traceability to national standards, which realize the physical units of measurements (SI).  
The measurements and the uncertainties with confidence probability are given on the following pages and are part of the certificate.

All calibrations have been conducted in the closed laboratory facility: environment temperature (22 ± 3)°C and humidity < 70%.

Calibration Equipment used (M&TE critical for calibration)

Primary Standards	ID #	Cal Date (Certificate No.)	Scheduled Calibration
Power meter EPM-442A	GB37480704	08-Oct-08 (No. 217-00898)	Oct-09
Power sensor HP 8481A	US37292783	08-Oct-08 (No. 217-00898)	Oct-09
Reference 20 dB Attenuator	SN: 5086 (20g)	31-Mar-09 (No. 217-01025)	Mar-10
Type-N mismatch combination	SN: 5047.2 / 06327	31-Mar-09 (No. 217-01029)	Mar-10
Reference Probe ES3DV3	SN: 3205	26-Jun-09 (No. ES3-3205_Jun09)	Jun-10
DAE4	SN: 601	07-Mar-09 (No. DAE4-601_Mar09)	Mar-10

Secondary Standards	ID #	Check Date (In house)	Scheduled Check
Power sensor HP 8481A	MY41092317	18-Oct-02 (in house check Oct-07)	In house check: Oct-09
RF generator R&S SMT-06	100005	4-Aug-99 (in house check Oct-07)	In house check: Oct-09
Network Analyzer HP 8753E	US37390585 S4206	18-Oct-01 (in house check Oct-08)	In house check: Oct-09

	<b>Name</b>	<b>Function</b>	<b>Signature</b>
Calibrated by:	<b>Jeton Kastrati</b>	<b>Laboratory Technician</b>	
Approved by:	<b>Katja Pokovic</b>	<b>Technical Manager</b>	

✓ok  
sz  
8/31/09

Issued: August 25, 2009

This calibration certificate shall not be reproduced except in full without written approval of the laboratory.



Accredited by the Swiss Accreditation Service (SAS)  
The Swiss Accreditation Service is one of the signatories to the EA  
Multilateral Agreement for the recognition of calibration certificates

Accreditation No.: **SCS 108**

**Glossary:**

TSL	tissue simulating liquid
ConvF	sensitivity in TSL / NORM x,y,z
N/A	not applicable or not measured

**Calibration is Performed According to the Following Standards:**

- a) IEEE Std 1528-2003, "IEEE Recommended Practice for Determining the Peak Spatial-Averaged Specific Absorption Rate (SAR) in the Human Head from Wireless Communications Devices: Measurement Techniques", December 2003
- b) IEC 62209-1, "Procedure to measure the Specific Absorption Rate (SAR) for hand-held devices used in close proximity to the ear (frequency range of 300 MHz to 3 GHz)", February 2005
- c) Federal Communications Commission Office of Engineering & Technology (FCC OET), "Evaluating Compliance with FCC Guidelines for Human Exposure to Radiofrequency Electromagnetic Fields; Additional Information for Evaluating Compliance of Mobile and Portable Devices with FCC Limits for Human Exposure to Radiofrequency Emissions", Supplement C (Edition 01-01) to Bulletin 65

**Additional Documentation:**

- d) DASY4/5 System Handbook

**Methods Applied and Interpretation of Parameters:**

- *Measurement Conditions:* Further details are available from the Validation Report at the end of the certificate. All figures stated in the certificate are valid at the frequency indicated.
- *Antenna Parameters with TSL:* The dipole is mounted with the spacer to position its feed point exactly below the center marking of the flat phantom section, with the arms oriented parallel to the body axis.
- *Feed Point Impedance and Return Loss:* These parameters are measured with the dipole positioned under the liquid filled phantom. The impedance stated is transformed from the measurement at the SMA connector to the feed point. The Return Loss ensures low reflected power. No uncertainty required.
- *Electrical Delay:* One-way delay between the SMA connector and the antenna feed point. No uncertainty required.
- *SAR measured:* SAR measured at the stated antenna input power.
- *SAR normalized:* SAR as measured, normalized to an input power of 1 W at the antenna connector.
- *SAR for nominal TSL parameters:* The measured TSL parameters are used to calculate the nominal SAR result.

## Measurement Conditions

DASY system configuration, as far as not given on page 1.

DASY Version	DASY5	V5.0
Extrapolation	Advanced Extrapolation	
Phantom	Modular Flat Phantom V4.9	
Distance Dipole Center - TSL	15 mm	with Spacer
Zoom Scan Resolution	dx, dy, dz = 5 mm	
Frequency	835 MHz $\pm$ 1 MHz	

## Head TSL parameters

The following parameters and calculations were applied.

	Temperature	Permittivity	Conductivity
Nominal Head TSL parameters	22.0 °C	41.5	0.90 mho/m
Measured Head TSL parameters	(22.0 $\pm$ 0.2) °C	41.2 $\pm$ 6 %	0.90 mho/m $\pm$ 6 %
Head TSL temperature during test	(22.0 $\pm$ 0.2) °C	----	----

## SAR result with Head TSL

SAR averaged over 1 cm <sup>3</sup> (1 g) of Head TSL	Condition	
SAR measured	250 mW input power	2.37 mW / g
SAR normalized	normalized to 1W	9.48 mW / g
SAR for nominal Head TSL parameters <sup>1</sup>	normalized to 1W	<b>9.46 mW / g <math>\pm</math> 17.0 % (k=2)</b>

SAR averaged over 10 cm <sup>3</sup> (10 g) of Head TSL	condition	
SAR measured	250 mW input power	1.55 mW / g
SAR normalized	normalized to 1W	6.20 mW / g
SAR for nominal Head TSL parameters <sup>1</sup>	normalized to 1W	<b>6.19 mW / g <math>\pm</math> 16.5 % (k=2)</b>

<sup>1</sup> Correction to nominal TSL parameters according to d), chapter "SAR Sensitivities"

## Body TSL parameters

The following parameters and calculations were applied.

	Temperature	Permittivity	Conductivity
Nominal Body TSL parameters	22.0 °C	55.2	0.97 mho/m
Measured Body TSL parameters	(22.0 ± 0.2) °C	53.4 ± 6 %	0.99 mho/m ± 6 %
Body TSL temperature during test	(22.5 ± 0.2) °C	----	----

## SAR result with Body TSL

SAR averaged over 1 cm <sup>3</sup> (1 g) of Body TSL	Condition	
SAR measured	250 mW input power	2.50 mW / g
SAR normalized	normalized to 1W	10.0 mW / g
SAR for nominal Body TSL parameters <sup>2</sup>	normalized to 1W	<b>9.78 mW / g ± 17.0 % (k=2)</b>

SAR averaged over 10 cm <sup>3</sup> (10 g) of Body TSL	condition	
SAR measured	250 mW input power	1.63 mW / g
SAR normalized	normalized to 1W	6.52 mW / g
SAR for nominal Body TSL parameters <sup>2</sup>	normalized to 1W	<b>6.42 mW / g ± 16.5 % (k=2)</b>

<sup>2</sup> Correction to nominal TSL parameters according to d), chapter "SAR Sensitivities"

## Appendix

### Antenna Parameters with Head TSL

Impedance, transformed to feed point	51.0 $\Omega$ - 7.5 j $\Omega$
Return Loss	- 22.5 dB

### Antenna Parameters with Body TSL

Impedance, transformed to feed point	46.9 $\Omega$ - 8.6 j $\Omega$
Return Loss	- 20.6 dB

### General Antenna Parameters and Design

Electrical Delay (one direction)	1.388 ns
----------------------------------	----------

After long term use with 100W radiated power, only a slight warming of the dipole near the feedpoint can be measured.

The dipole is made of standard semirigid coaxial cable. The center conductor of the feeding line is directly connected to the second arm of the dipole. The antenna is therefore short-circuited for DC-signals.

No excessive force must be applied to the dipole arms, because they might bend or the soldered connections near the feedpoint may be damaged.

### Additional EUT Data

Manufactured by	SPEAG
Manufactured on	December 17, 2004

## DASY5 Validation Report for Head TSL

Date/Time: 24.08.2009 13:11:23

Test Laboratory: SPEAG, Zurich, Switzerland

**DUT: Dipole 835 MHz; Type: D835V2; Serial: D835V2 - SN:4d026**

Communication System: CW-835; Frequency: 835 MHz; Duty Cycle: 1:1

Medium: HSL 900 MHz

Medium parameters used:  $f = 835$  MHz;  $\sigma = 0.9$  mho/m;  $\epsilon_r = 41.2$ ;  $\rho = 1000$  kg/m<sup>3</sup>

Phantom section: Flat Section

Measurement Standard: DASY5 (IEEE/IEC)

### DASY5 Configuration:

- Probe: ES3DV3 - SN3205; ConvF(6.04, 6.04, 6.04); Calibrated: 26.06.2009
- Sensor-Surface: 3mm (Mechanical Surface Detection)
- Electronics: DAE4 Sn601; Calibrated: 07.03.2009
- Phantom: Flat Phantom 4.9L; Type: QD000P49AA; Serial: 1001
- Measurement SW: DASY5, V5.0 Build 120; SEMCAD X Version 13.4 Build 45

**Pin=250mW; dip=15mm/Zoom Scan (7x7x7)/Cube 0:** Measurement grid: dx=5mm, dy=5mm, dz=5mm

Reference Value = 57.1 V/m; Power Drift = 0.016 dB

Peak SAR (extrapolated) = 3.55 W/kg

**SAR(1 g) = 2.37 mW/g; SAR(10 g) = 1.55 mW/g**

Maximum value of SAR (measured) = 2.77 mW/g

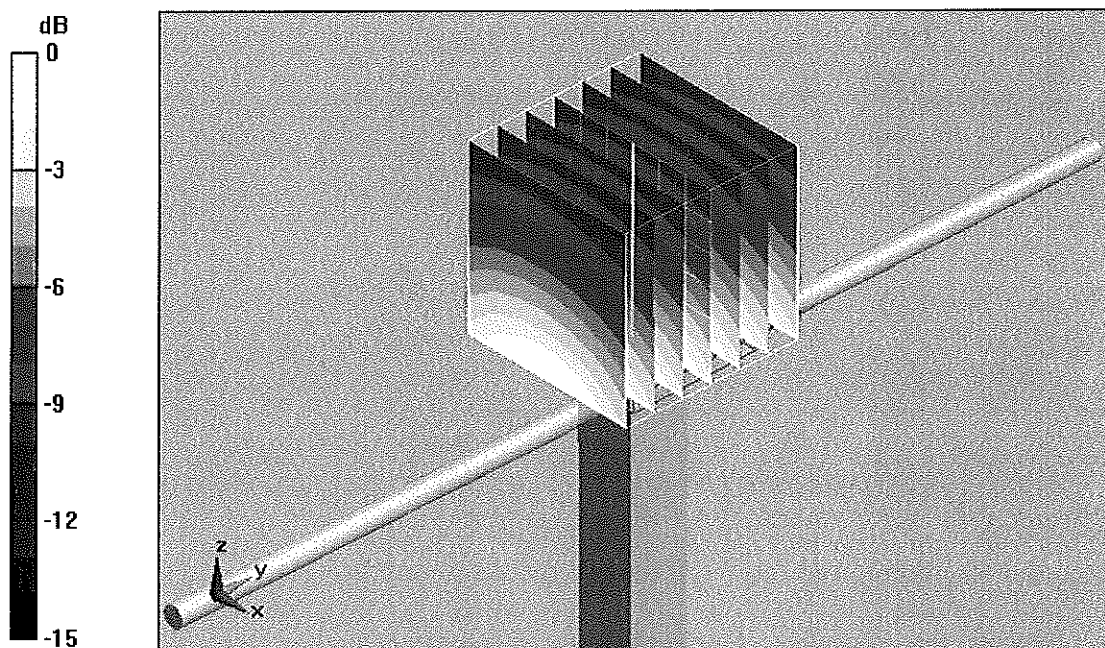

0 dB = 2.77mW/g

# Impedance Measurement Plot for Head TSL

24 Aug 2009 11:32:41

CH1 S11 1 U FS 1: 50.971  $\Omega$  -7.4922  $\Omega$  25.440 pF 835.000 000 MHz

\*  
De1  
CA

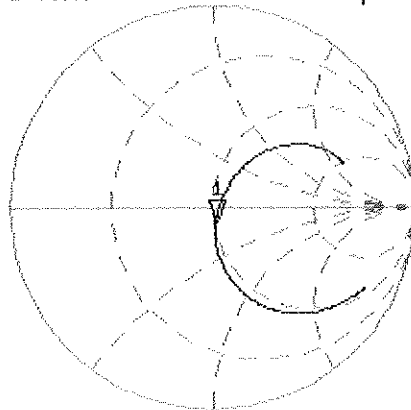

Avg  
16  
↑

CH2 S11 LOG 5 dB/REF -20 dB 1: -22.544 dB 835.000 000 MHz

CA  
Avg  
16  
↑

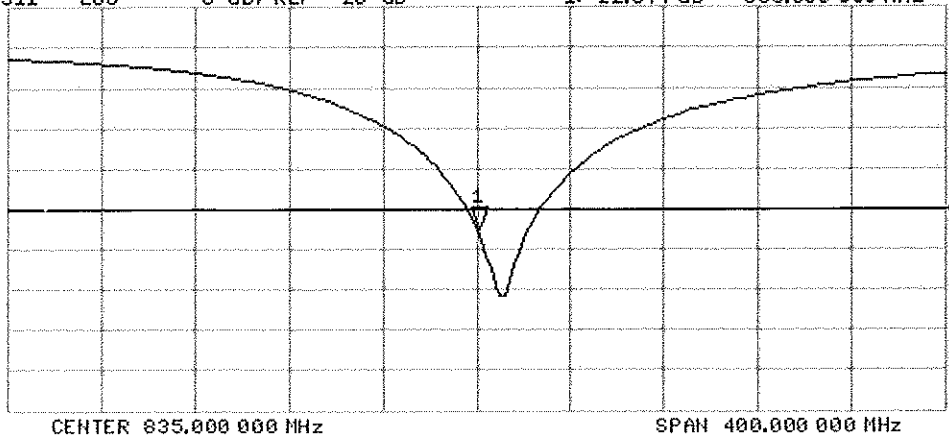

## DASY5 Validation Report for Body TSL

Date/Time: 17.08.2009 09:50:53

Test Laboratory: SPEAG, Zurich, Switzerland

**DUT: Dipole 835 MHz; Type: D835V2; Serial: D835V2 - SN:4d026**

Communication System: CW; Frequency: 835 MHz; Duty Cycle: 1:1

Medium: MSL900

Medium parameters used:  $f = 835$  MHz;  $\sigma = 0.99$  mho/m;  $\epsilon_r = 53.4$ ;  $\rho = 1000$  kg/m<sup>3</sup>

Phantom section: Flat Section

Measurement Standard: DASY5 (IEEE/IEC)

### DASY5 Configuration:

- Probe: ES3DV3 - SN3205; ConvF(5.97, 5.97, 5.97); Calibrated: 26.06.2009
- Sensor-Surface: 3mm (Mechanical Surface Detection)
- Electronics: DAE4 Sn601; Calibrated: 07.03.2009
- Phantom: Flat Phantom 4.9L; Type: QD000P49AA; Serial: 1001
- Measurement SW: DASY5, V5.0 Build 120; SEMCAD X Version 13.4 Build 45

**Pin = 250mW, d = 15mm/Zoom Scan (7x7x7)/Cube 0:** Measurement grid: dx=5mm, dy=5mm, dz=5mm

Reference Value = 55.8 V/m; Power Drift = 0.014 dB

Peak SAR (extrapolated) = 3.71 W/kg

**SAR(1 g) = 2.5 mW/g; SAR(10 g) = 1.63 mW/g**

Maximum value of SAR (measured) = 2.92 mW/g

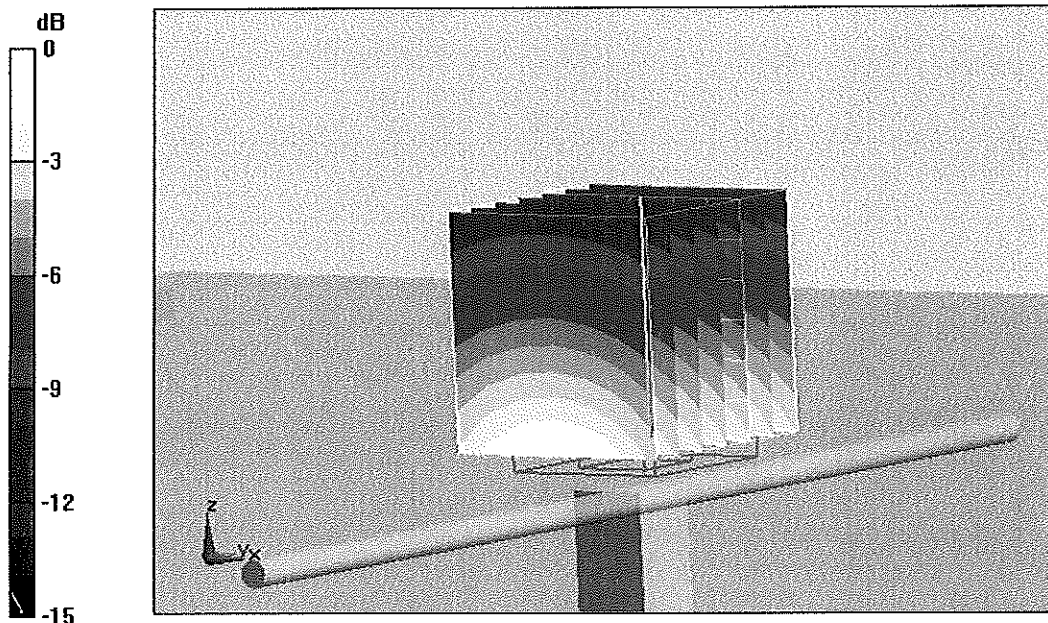

0 dB = 2.92mW/g

# Impedance Measurement Plot for Body TSL

17 Aug 2009 08:48:23

CH1 S11 1 U FS 1: 46.928  $\Omega$  -8.5547  $\Omega$  22.281 pF 835.000 000 MHz

\*  
Del  
Cor  
Avg  
16  
↑

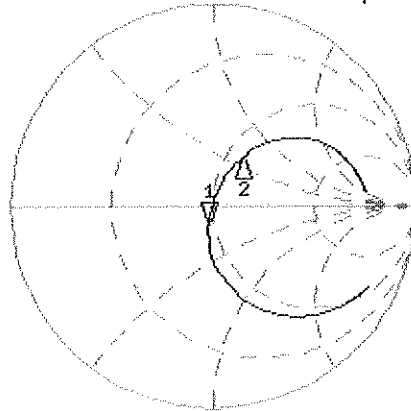

CH1 Markers  
2: 58.551  $\Omega$   
30.164  $\Omega$   
900.000 MHz

CH2 S11 LOG 5 dB/REF -20 dB 1: -20.592 dB 835.000 000 MHz

Cor  
Avg  
16  
↑

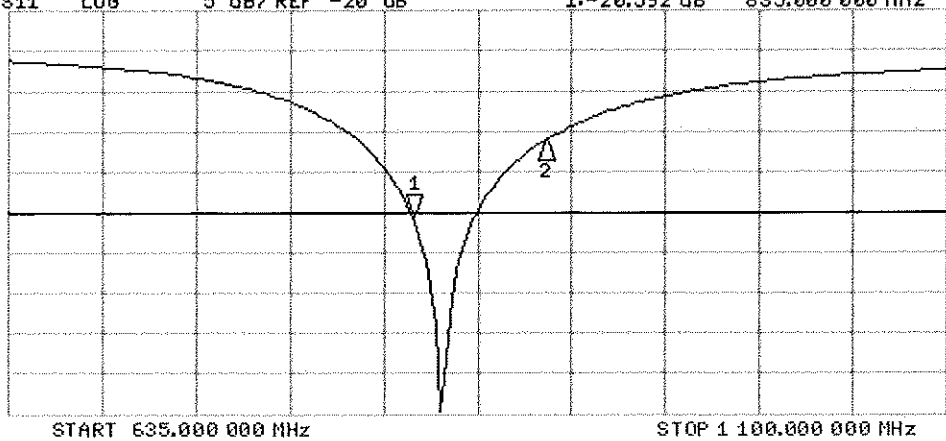

CH2 Markers  
2: -11.110 dB  
900.000 MHz



Accredited by the Swiss Accreditation Service (SAS)  
The Swiss Accreditation Service is one of the signatories to the EA  
Multilateral Agreement for the recognition of calibration certificates

Accreditation No.: **SCS 108**

Client **PC Test**

Certificate No: **D1900V2-502\_Feb11**

## CALIBRATION CERTIFICATE

Object **D1900V2 - SN: 502**

Calibration procedure(s) **QA CAL-05.v8  
Calibration procedure for dipole validation kits**

Calibration date: **February 17, 2011**

✓  
KOK  
2/24/11

This calibration certificate documents the traceability to national standards, which realize the physical units of measurements (SI).  
The measurements and the uncertainties with confidence probability are given on the following pages and are part of the certificate.

All calibrations have been conducted in the closed laboratory facility: environment temperature (22 ± 3)°C and humidity < 70%.

Calibration Equipment used (M&TE critical for calibration)

Primary Standards	ID #	Cal Date (Certificate No.)	Scheduled Calibration
Power meter EPM-442A	GB37480704	06-Oct-10 (No. 217-01266)	Oct-11
Power sensor HP 8481A	US37292783	06-Oct-10 (No. 217-01266)	Oct-11
Reference 20 dB Attenuator	SN: 5086 (20g)	30-Mar-10 (No. 217-01158)	Mar-11
Type-N mismatch combination	SN: 5047.2 / 06327	30-Mar-10 (No. 217-01162)	Mar-11
Reference Probe ES3DV3	SN: 3205	30-Apr-10 (No. ES3-3205_Apr10)	Apr-11
DAE4	SN: 601	10-Jun-10 (No. DAE4-601_Jun10)	Jun-11
Secondary Standards	ID #	Check Date (in house)	Scheduled Check
Power sensor HP 8481A	MY41092317	18-Oct-02 (in house check Oct-09)	In house check: Oct-11
RF generator R&S SMT-06	100005	4-Aug-99 (in house check Oct-09)	In house check: Oct-11
Network Analyzer HP 8753E	US37390585 S4206	18-Oct-01 (in house check Oct-10)	In house check: Oct-11

Calibrated by: **Dimce Iliev**      **Function: Laboratory Technician**      **Signature: [Signature]**

Approved by: **Katja Pokovic**      **Technical Manager**      **[Signature]**

Issued: February 17, 2011

This calibration certificate shall not be reproduced except in full without written approval of the laboratory.



Accredited by the Swiss Accreditation Service (SAS)

The Swiss Accreditation Service is one of the signatories to the EA  
Multilateral Agreement for the recognition of calibration certificates

Accreditation No.: **SCS 108**

### Glossary:

TSL	tissue simulating liquid
ConvF	sensitivity in TSL / NORM x,y,z
N/A	not applicable or not measured

### Calibration is Performed According to the Following Standards:

- IEEE Std 1528-2003, "IEEE Recommended Practice for Determining the Peak Spatial-Averaged Specific Absorption Rate (SAR) in the Human Head from Wireless Communications Devices: Measurement Techniques", December 2003
- IEC 62209-1, "Procedure to measure the Specific Absorption Rate (SAR) for hand-held devices used in close proximity to the ear (frequency range of 300 MHz to 3 GHz)", February 2005
- Federal Communications Commission Office of Engineering & Technology (FCC OET), "Evaluating Compliance with FCC Guidelines for Human Exposure to Radiofrequency Electromagnetic Fields; Additional Information for Evaluating Compliance of Mobile and Portable Devices with FCC Limits for Human Exposure to Radiofrequency Emissions", Supplement C (Edition 01-01) to Bulletin 65

### Additional Documentation:

- DASY4/5 System Handbook

### Methods Applied and Interpretation of Parameters:

- Measurement Conditions:** Further details are available from the Validation Report at the end of the certificate. All figures stated in the certificate are valid at the frequency indicated.
- Antenna Parameters with TSL:** The dipole is mounted with the spacer to position its feed point exactly below the center marking of the flat phantom section, with the arms oriented parallel to the body axis.
- Feed Point Impedance and Return Loss:** These parameters are measured with the dipole positioned under the liquid filled phantom. The impedance stated is transformed from the measurement at the SMA connector to the feed point. The Return Loss ensures low reflected power. No uncertainty required.
- Electrical Delay:** One-way delay between the SMA connector and the antenna feed point. No uncertainty required.
- SAR measured:** SAR measured at the stated antenna input power.
- SAR normalized:** SAR as measured, normalized to an input power of 1 W at the antenna connector.
- SAR for nominal TSL parameters:** The measured TSL parameters are used to calculate the nominal SAR result.

## Measurement Conditions

DASY system configuration, as far as not given on page 1.

DASY Version	DASY5	V52.6
Extrapolation	Advanced Extrapolation	
Phantom	Modular Flat Phantom V5.0	
Distance Dipole Center - TSL	10 mm	with Spacer
Zoom Scan Resolution	dx, dy, dz = 5 mm	
Frequency	1900 MHz $\pm$ 1 MHz	

## Head TSL parameters

The following parameters and calculations were applied.

	Temperature	Permittivity	Conductivity
Nominal Head TSL parameters	22.0 °C	40.0	1.40 mho/m
Measured Head TSL parameters	(22.0 $\pm$ 0.2) °C	39.8 $\pm$ 6 %	1.41 mho/m $\pm$ 6 %
Head TSL temperature during test	(21.5 $\pm$ 0.2) °C	----	----

## SAR result with Head TSL

SAR averaged over 1 cm <sup>3</sup> (1 g) of Head TSL	Condition	
SAR measured	250 mW input power	10.1 mW / g
SAR normalized	normalized to 1W	40.4 mW / g
SAR for nominal Head TSL parameters	normalized to 1W	<b>40.2 mW / g <math>\pm</math> 17.0 % (k=2)</b>

SAR averaged over 10 cm <sup>3</sup> (10 g) of Head TSL	condition	
SAR measured	250 mW input power	5.26 mW / g
SAR normalized	normalized to 1W	21.0 mW / g
SAR for nominal Head TSL parameters	normalized to 1W	<b>21.0 mW / g <math>\pm</math> 16.5 % (k=2)</b>

## Body TSL parameters

The following parameters and calculations were applied.

	Temperature	Permittivity	Conductivity
Nominal Body TSL parameters	22.0 °C	53.3	1.52 mho/m
Measured Body TSL parameters	(22.0 ± 0.2) °C	52.8 ± 6 %	1.55 mho/m ± 6 %
Body TSL temperature during test	(21.5 ± 0.2) °C	----	----

## SAR result with Body TSL

SAR averaged over 1 cm <sup>3</sup> (1 g) of Body TSL	Condition	
SAR measured	250 mW input power	10.4 mW / g
SAR normalized	normalized to 1W	41.6 mW / g
SAR for nominal Body TSL parameters	normalized to 1W	<b>41.1 mW / g ± 17.0 % (k=2)</b>

SAR averaged over 10 cm <sup>3</sup> (10 g) of Body TSL	condition	
SAR measured	250 mW input power	5.48 mW / g
SAR normalized	normalized to 1W	21.9 mW / g
SAR for nominal Body TSL parameters	normalized to 1W	<b>21.8 mW / g ± 16.5 % (k=2)</b>

## Appendix

### Antenna Parameters with Head TSL

Impedance, transformed to feed point	51.3 $\Omega$ + 6.4 j $\Omega$
Return Loss	- 23.8 dB

### Antenna Parameters with Body TSL

Impedance, transformed to feed point	47.3 $\Omega$ + 6.7 j $\Omega$
Return Loss	- 22.5 dB

### General Antenna Parameters and Design

Electrical Delay (one direction)	1.206 ns
----------------------------------	----------

After long term use with 100W radiated power, only a slight warming of the dipole near the feedpoint can be measured.

The dipole is made of standard semirigid coaxial cable. The center conductor of the feeding line is directly connected to the second arm of the dipole. The antenna is therefore short-circuited for DC-signals.

No excessive force must be applied to the dipole arms, because they might bend or the soldered connections near the feedpoint may be damaged.

### Additional EUT Data

Manufactured by	SPEAG
Manufactured on	November 14, 1998

# DASY5 Validation Report for Head TSL

Date/Time: 17.02.2011 10:13:23

Test Laboratory: SPEAG, Zurich, Switzerland

**DUT: Dipole 1900 MHz; Type: D1900V2; Serial: D1900V2 - SN:502**

Communication System: CW; Frequency: 1900 MHz; Duty Cycle: 1:1

Medium: HSL U12 BB

Medium parameters used:  $f = 1900$  MHz;  $\sigma = 1.41$  mho/m;  $\epsilon_r = 39.9$ ;  $\rho = 1000$  kg/m<sup>3</sup>

Phantom section: Flat Section

Measurement Standard: DASY5 (IEEE/IEC/ANSI C63.19-2007)

DASY5 Configuration:

- Probe: ES3DV3 - SN3205; ConvF(5.09, 5.09, 5.09); Calibrated: 30.04.2010
- Sensor-Surface: 3mm (Mechanical Surface Detection)
- Electronics: DAE4 Sn601; Calibrated: 10.06.2010
- Phantom: Flat Phantom 5.0 (front); Type: QD000P50AA; Serial: 1001
- Measurement SW: DASY52, V52.6.1 Build (408)
- Postprocessing SW: SEMCAD X, V14.4.2 Build (2595)

**Pin=250 mW /d=10mm, dist=3.0mm (ES-Probe)/Zoom Scan (7x7x7) /Cube 0: Measurement grid: dx=5mm, dy=5mm, dz=5mm**

Reference Value = 97.159 V/m; Power Drift = 0.05 dB

Peak SAR (extrapolated) = 18.519 W/kg

**SAR(1 g) = 10.1 mW/g; SAR(10 g) = 5.26 mW/g**

Maximum value of SAR (measured) = 12.407 mW/g

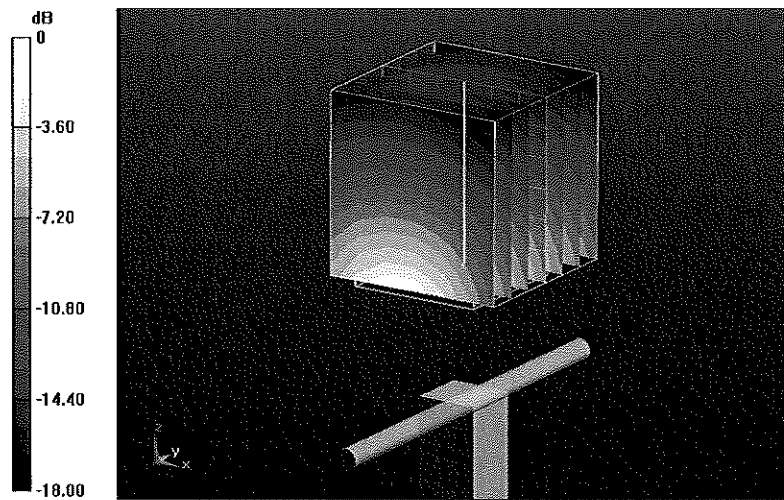

0 dB = 12.410mW/g

# Impedance Measurement Plot for Head TSL

17 Feb 2011 10:39:45

CH1 S11 1 U FS 3: 51.264  $\Omega$  6.4219  $\Omega$  537.93  $\mu$ H 1 900.000 000 MHz

\*  
Del  
CA

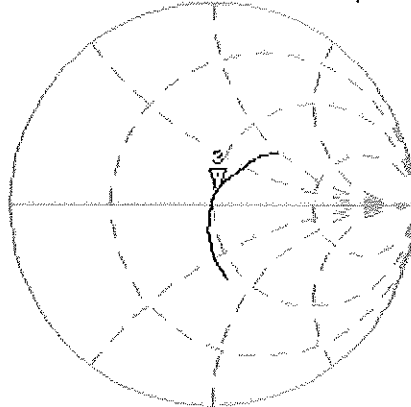

Avg  
16

CH2 S11 LOG 5 dB/REF -20 dB 3:-23.804 dB 1 900.000 000 MHz

CA  
Avg  
16

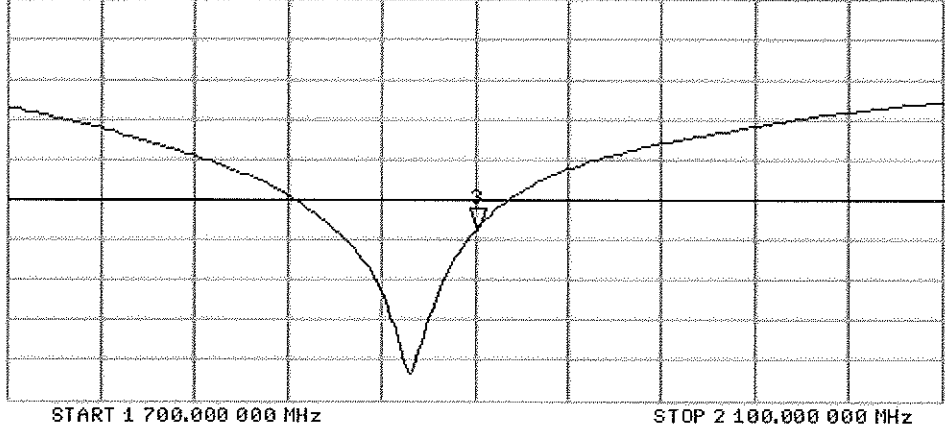

## DASY5 Validation Report for Body TSL

Date/Time: 17.02.2011 10:55:26

Test Laboratory: SPEAG, Zurich, Switzerland

**DUT: Dipole 1900 MHz; Type: D1900V2; Serial: D1900V2 - SN:502**

Communication System: CW; Frequency: 1900 MHz; Duty Cycle: 1:1

Medium: MSL U12 BB

Medium parameters used:  $f = 1900$  MHz;  $\sigma = 1.55$  mho/m;  $\epsilon_r = 52.9$ ;  $\rho = 1000$  kg/m<sup>3</sup>

Phantom section: Flat Section

Measurement Standard: DASY5 (IEEE/IEC/ANSI C63.19-2007)

DASY5 Configuration:

- Probe: ES3DV3 - SN3205; ConvF(4.59, 4.59, 4.59); Calibrated: 30.04.2010
- Sensor-Surface: 3mm (Mechanical Surface Detection)
- Electronics: DAE4 Sn601; Calibrated: 10.06.2010
- Phantom: Flat Phantom 5.0 (back); Type: QD000P50AA; Serial: 1002
- Measurement SW: DASY52, V52.6.1 Build (408)
- Postprocessing SW: SEMCAD X, V14.4.2 Build (2595)

**Pin=250 mW /d=10mm, dist=3.0mm (ES-Probe)/Zoom Scan (7x7x7) /Cube 0: Measurement grid: dx=5mm, dy=5mm, dz=5mm**

Reference Value = 96.636 V/m; Power Drift = -0.02 dB

Peak SAR (extrapolated) = 17.829 W/kg

**SAR(1 g) = 10.4 mW/g; SAR(10 g) = 5.48 mW/g**

Maximum value of SAR (measured) = 13.070 mW/g

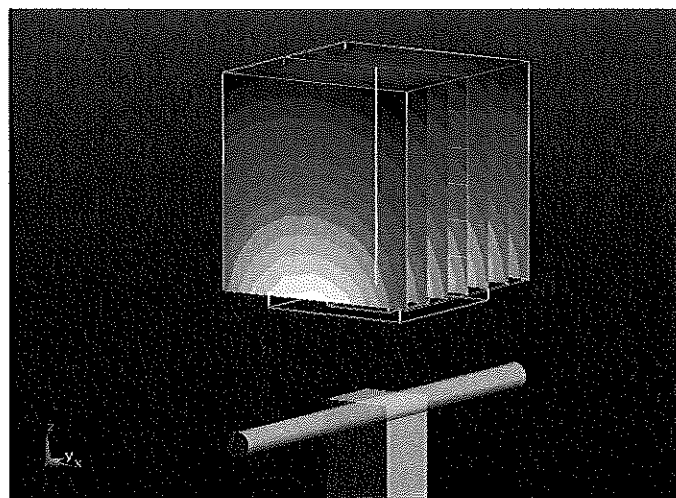

0 dB = 13.070mW/g

# Impedance Measurement Plot for Body TSL

17 Feb 2011 10:40:17

CH1 S11 1 U FS 3: 47.260  $\Omega$  6.7480  $\Omega$  565.26  $\mu$ H 1 900.000 000 MHz

\*  
De1  
CA

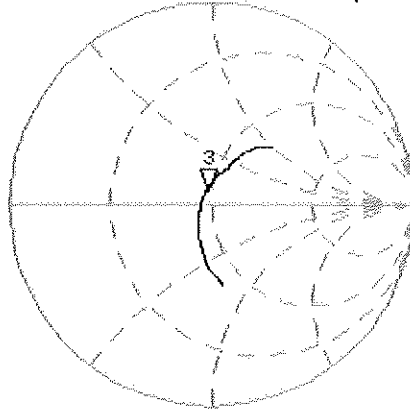

Avg  
16  
↑

CH2 S11 LOG 5 dB/REF -20 dB 3:-22.531 dB 1 900.000 000 MHz

CA

Avg  
16  
↑

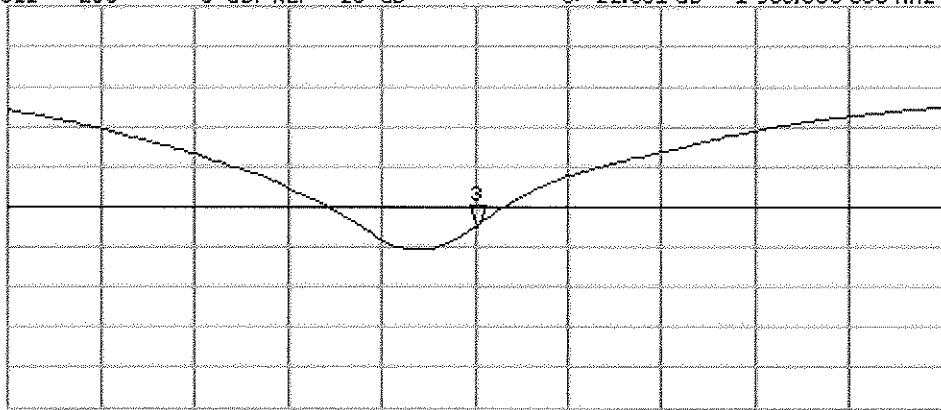

START 1 700.000 000 MHz

STOP 2 100.000 000 MHz



Accredited by the Swiss Accreditation Service (SAS)  
The Swiss Accreditation Service is one of the signatories to the EA  
Multilateral Agreement for the recognition of calibration certificates

Accreditation No.: **SCS 108**

Client **PC Test**

Certificate No: **D1765V2-1008\_May09**

**CALIBRATION CERTIFICATE**

Object **D1765V2 - SN: 1008**

Calibration procedure(s) **QA CAL-05.v7  
Calibration procedure for dipole validation kits**

*OK  
82  
5/26/09*

Calibration date: **May 19, 2009**

Condition of the calibrated item **In Tolerance**

This calibration certificate documents the traceability to national standards, which realize the physical units of measurements (SI).  
The measurements and the uncertainties with confidence probability are given on the following pages and are part of the certificate.

All calibrations have been conducted in the closed laboratory facility: environment temperature (22 ± 3)°C and humidity < 70%.

Calibration Equipment used (M&TE critical for calibration)

Primary Standards	ID #	Cal Date (Calibrated by, Certificate No.)	Scheduled Calibration
Power meter EPM-442A	GB37480704	08-Oct-08 (No. 217-00898)	Oct-09
Power sensor HP 8481A	US37292783	08-Oct-08 (No. 217-00898)	Oct-09
Reference 20 dB Attenuator	SN: 5086 (20g)	31-Mar-09 (No. 217-01025)	Mar-10
Type-N mismatch combination	SN: 5047.2 / 06327	31-Mar-09 (No. 217-01029)	Mar-10
Reference Probe ES3DV2	SN: 3025	30-Apr-09 (No. ES3-3025_Apr09)	Apr-10
DAE4	SN: 601	07-Mar-09 (No. DAE4-601_Mar09)	Mar-10
Secondary Standards	ID #	Check Date (in house)	Scheduled Check
Power sensor HP 8481A	MY41092317	18-Oct-02 (in house check Oct-07)	In house check: Oct-09
RF generator R&S SMT-06	100005	4-Aug-99 (in house check Oct-07)	In house check: Oct-09
Network Analyzer HP 8753E	US37390585 S4206	18-Oct-01 (in house check Oct-08)	In house check: Oct-09

Calibrated by: **Name: Mike Meili, Function: Laboratory Technician, Signature: [Signature]**

Approved by: **Name: Kalja Pokovic, Function: Technical Manager, Signature: [Signature]**

Issued: May 20, 2009

This calibration certificate shall not be reproduced except in full without written approval of the laboratory.



Accredited by the Swiss Accreditation Service (SAS)  
The Swiss Accreditation Service is one of the signatories to the EA  
Multilateral Agreement for the recognition of calibration certificates

Accreditation No.: **SCS 108**

### Glossary:

TSL	tissue simulating liquid
ConvF	sensitivity in TSL / NORM x,y,z
N/A	not applicable or not measured

### Calibration is Performed According to the Following Standards:

- IEEE Std 1528-2003, "IEEE Recommended Practice for Determining the Peak Spatial-Averaged Specific Absorption Rate (SAR) in the Human Head from Wireless Communications Devices: Measurement Techniques", December 2003
- IEC 62209-1, "Procedure to measure the Specific Absorption Rate (SAR) for hand-held devices used in close proximity to the ear (frequency range of 300 MHz to 3 GHz)", February 2005
- Federal Communications Commission Office of Engineering & Technology (FCC OET), "Evaluating Compliance with FCC Guidelines for Human Exposure to Radiofrequency Electromagnetic Fields; Additional Information for Evaluating Compliance of Mobile and Portable Devices with FCC Limits for Human Exposure to Radiofrequency Emissions", Supplement C (Edition 01-01) to Bulletin 65

### Additional Documentation:

- DASY4/5 System Handbook

### Methods Applied and Interpretation of Parameters:

- Measurement Conditions:** Further details are available from the Validation Report at the end of the certificate. All figures stated in the certificate are valid at the frequency indicated.
- Antenna Parameters with TSL:** The dipole is mounted with the spacer to position its feed point exactly below the center marking of the flat phantom section, with the arms oriented parallel to the body axis.
- Feed Point Impedance and Return Loss:** These parameters are measured with the dipole positioned under the liquid filled phantom. The impedance stated is transformed from the measurement at the SMA connector to the feed point. The Return Loss ensures low reflected power. No uncertainty required.
- Electrical Delay:** One-way delay between the SMA connector and the antenna feed point. No uncertainty required.
- SAR measured:** SAR measured at the stated antenna input power.
- SAR normalized:** SAR as measured, normalized to an input power of 1 W at the antenna connector.
- SAR for nominal TSL parameters:** The measured TSL parameters are used to calculate the nominal SAR result.

## Measurement Conditions

DASY system configuration, as far as not given on page 1.

DASY Version	DASY5	V5.0
Extrapolation	Advanced Extrapolation	
Phantom	Modular Flat Phantom V5.0	
Distance Dipole Center - TSL	10 mm	with Spacer
Zoom Scan Resolution	dx, dy, dz = 5 mm	
Frequency	1765 MHz $\pm$ 1 MHz	

## Head TSL parameters

The following parameters and calculations were applied.

	Temperature	Permittivity	Conductivity
Nominal Head TSL parameters	22.0 °C	40.1	1.38 mho/m
Measured Head TSL parameters	(22.0 $\pm$ 0.2) °C	41.4 $\pm$ 6 %	1.36 mho/m $\pm$ 6 %
Head TSL temperature during test	(21.4 $\pm$ 0.2) °C	----	----

## SAR result with Head TSL

SAR averaged over 1 cm <sup>3</sup> (1 g) of Head TSL	condition	
SAR measured	250 mW input power	9.38 mW /g
SAR normalized	normalized to 1W	37.5 mW /g
SAR for nominal Head TSL parameters <sup>1</sup>	normalized to 1W	<b>38.2 mW/g <math>\pm</math> 17.0 % (k=2)</b>

SAR averaged over 10 cm <sup>3</sup> (10 g) of Head TSL	condition	
SAR measured	250 mW input power	5.02 mW /g
SAR normalized	normalized to 1W	20.1 mW /g
SAR for nominal Head TSL parameters <sup>1</sup>	normalized to 1W	<b>20.3 W/g <math>\pm</math> 16.5 % (k=2)</b>

<sup>1</sup> Correction to nominal TSL parameters according to d), chapter "SAR Sensitivities"

## Body TSL parameters

The following parameters and calculations were applied.

	Temperature	Permittivity	Conductivity
Nominal Body TSL parameters	22.0 °C	53.4	1.50 mho/m
Measured Body TSL parameters	(22.0 ± 0.2) °C	53.8 ± 6 %	1.47 mho/m ± 6 %
Body TSL temperature during test	(21.0 ± 0.2) °C	----	----

## SAR result with Body TSL

SAR averaged over 1 cm <sup>3</sup> (1 g) of Body TSL	condition	
SAR measured	250 mW input power	9.19 mW /g
SAR normalized	normalized to 1W	36.6 mW /g
SAR for nominal Body TSL parameters <sup>2</sup>	normalized to 1W	<b>37.3 mW / g ± 17.0 % (k=2)</b>

SAR averaged over 10 cm <sup>3</sup> (10 g) of Body TSL	condition	
SAR measured	250 mW input power	4.97 mW /g
SAR normalized	normalized to 1W	19.9 mW /g
SAR for nominal Body TSL parameters <sup>2</sup>	normalized to 1W	<b>20.0 mW / g ± 16.5 % (k=2)</b>

<sup>2</sup> Correction to nominal TSL parameters according to d), chapter "SAR Sensitivities"

## Appendix

### Antenna Parameters with Head TSL

Impedance, transformed to feed point	48.4 $\Omega$ - 2.7 j $\Omega$
Return Loss	- 29.9 dB

### Antenna Parameters with Body TSL

Impedance, transformed to feed point	44.8 $\Omega$ - 2.6 j $\Omega$
Return Loss	- 24.2 dB

### General Antenna Parameters and Design

Electrical Delay (one direction)	1.210 ns
----------------------------------	----------

After long term use with 100W radiated power, only a slight warming of the dipole near the feedpoint can be measured.

The dipole is made of standard semirigid coaxial cable. The center conductor of the feeding line is directly connected to the second arm of the dipole. The antenna is therefore short-circuited for DC-signals.

No excessive force must be applied to the dipole arms, because they might bend or the soldered connections near the feedpoint may be damaged.

### Additional EUT Data

Manufactured by	SPEAG
Manufactured on	October 6, 2005

## DASY5 Validation Report for Head TSL

Date/Time: 19.05.2009 13:14:46

Test Laboratory: SPEAG, Zurich, Switzerland

**DUT: Dipole 1765 MHz; Type: D1765V2; Serial: D1765V2 - SN1008**

Communication System: CW-1750; Frequency: 1765 MHz; Duty Cycle: 1:1

Medium: HSL U11 BB

Medium parameters used:  $f = 1765$  MHz;  $\sigma = 1.36$  mho/m;  $\epsilon_r = 41.5$ ;  $\rho = 1000$  kg/m<sup>3</sup>

Phantom section: Flat Section

Measurement Standard: DASY5 (IEEE/IEC)

DASY5 Configuration:

- Probe: ES3DV2 - SN3025; ConvF(5.04, 5.04, 5.04); Calibrated: 30.04.2009
- Sensor-Surface: 3mm (Mechanical Surface Detection)
- Electronics: DAE4 Sn601; Calibrated: 07.03.2009
- Phantom: Flat Phantom 5.0 (front); Type: QD000P50AA; Serial: 1001
- Measurement SW: DASY5, V5.0 Build 120; SEMCAD X Version 13.4 Build 45

**Pin = 250 mW; d = 10 mm, f = 1765 MHz/Zoom Scan (7x7x7)/Cube 0:**

Measurement grid: dx=5mm, dy=5mm, dz=5mm

Reference Value = 95.1 V/m; Power Drift = 0.048 dB

Peak SAR (extrapolated) = 16.7 W/kg

**SAR(1 g) = 9.38 mW/g; SAR(10 g) = 5.02 mW/g**

Maximum value of SAR (measured) = 11.5 mW/g

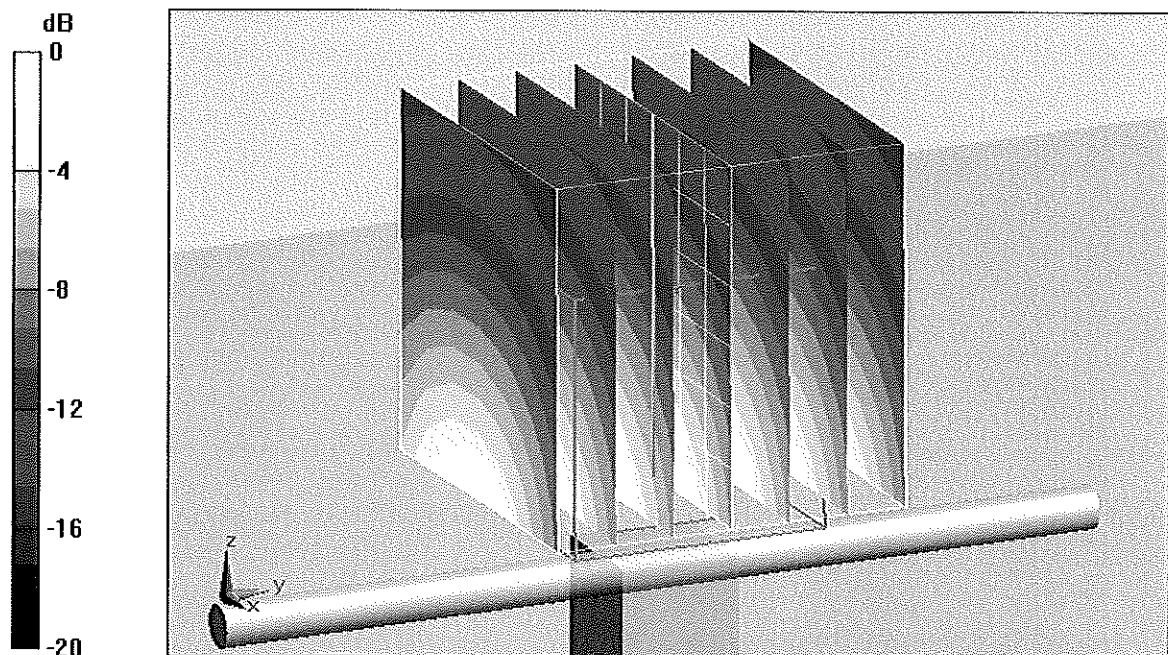

0 dB = 11.5mW/g

# Impedance Measurement Plot for Head TSL

19 May 2009 10:36:08

[CH1] S11 1 U FS 1: 48.412  $\Omega$  -2.7422  $\Omega$  32.884  $\mu$ F 1 765.000 000 MHz

\*  
Del  
CA

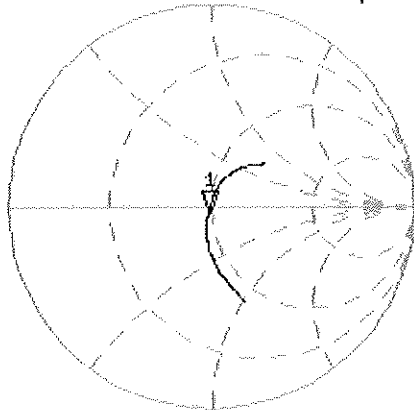

Avg  
16

↑

CH2 S11 LOG 5 dB/REF -20 dB 1:-29.856 dB 1 765.000 000 MHz

CA

Avg  
16

↑

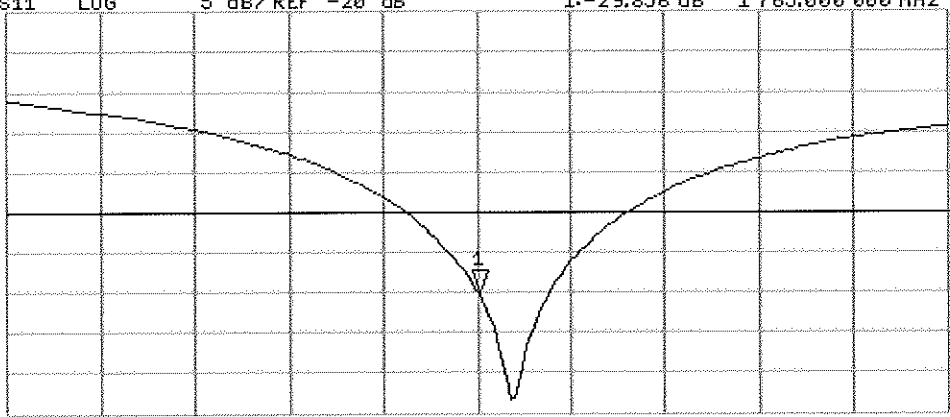

CENTER 1 765.000 000 MHz

SPAN 400.000 000 MHz

## DASY5 Validation Report for Body TSL

Date/Time: 19.05.2009 15:46:05

Test Laboratory: SPEAG, Zurich, Switzerland

**DUT: Dipole 1765 MHz; Type: D1765V2; Serial: D1765V2 - SN1008**

Communication System: CW-1750; Frequency: 1765 MHz; Duty Cycle: 1:1

Medium: MSL U10 BB

Medium parameters used:  $f = 1765$  MHz;  $\sigma = 1.47$  mho/m;  $\epsilon_r = 54$ ;  $\rho = 1000$  kg/m<sup>3</sup>

Phantom section: Flat Section

Measurement Standard: DASY5 (IEEE/IEC)

### DASY5 Configuration:

- Probe: ES3DV2 - SN3025; ConvF(4.71, 4.71, 4.71); Calibrated: 30.04.2009
- Sensor-Surface: 3mm (Mechanical Surface Detection)
- Electronics: DAE4 Sn601; Calibrated: 07.03.2009
- Phantom: Flat Phantom 5.0 (back); Type: QD000P50AA; Serial: 1002
- Measurement SW: DASY5, V5.0 Build 120; SEMCAD X Version I3.4 Build 45

**Pin = 250 mW; d = 10 mm, f = 1765 MHz/Zoom Scan (7x7x7)/Cube 0:**

Measurement grid: dx=5mm, dy=5mm, dz=5mm

Reference Value = 92.4 V/m; Power Drift = 0.00676 dB

Peak SAR (extrapolated) = 15.7 W/kg

**SAR(1 g) = 9.19 mW/g; SAR(10 g) = 4.97 mW/g**

Maximum value of SAR (measured) = 11.5 mW/g

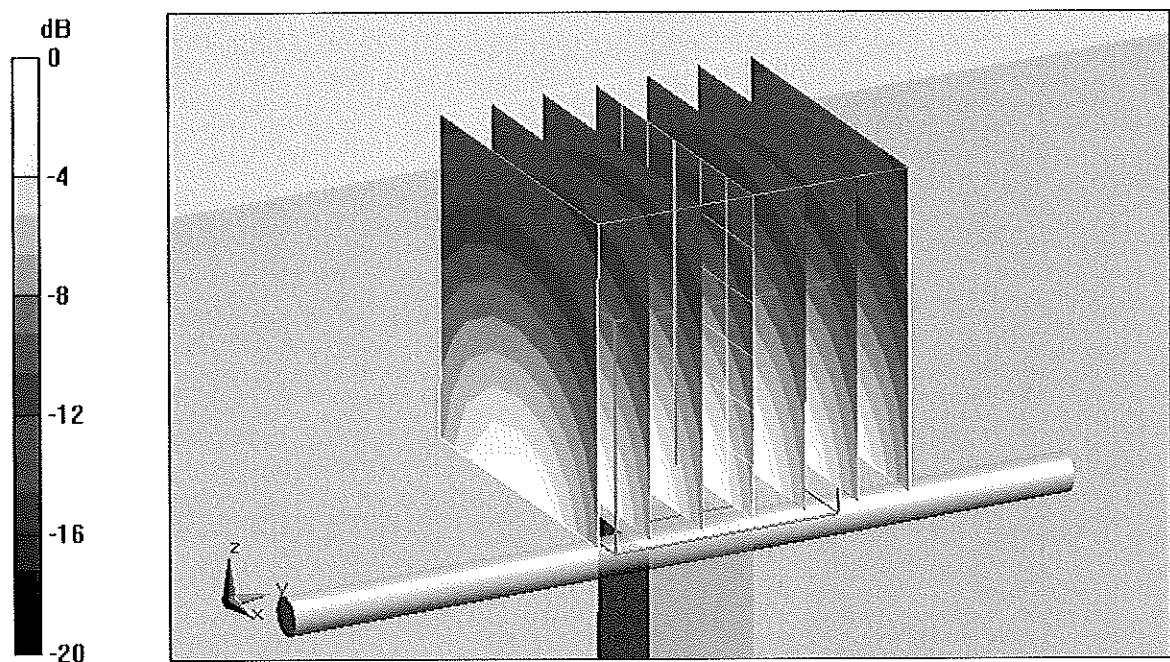

0 dB = 11.5mW/g

# Impedance Measurement Plot for Body TSL

19 May 2009 10:36:41  
CH1 S11 1 U FS 1: 44.799  $\Omega$  -2.6426  $\Omega$  34.123 pF 1 765.000 000 MHz

\*  
De1  
CΔ  
Avg  
16  
↑

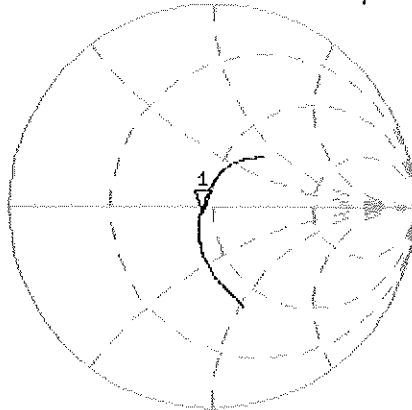

CH2 S11 LOG 5 dB/REF -20 dB 1:-24.219 dB 1 765.000 000 MHz

CΔ  
Avg  
16  
↑

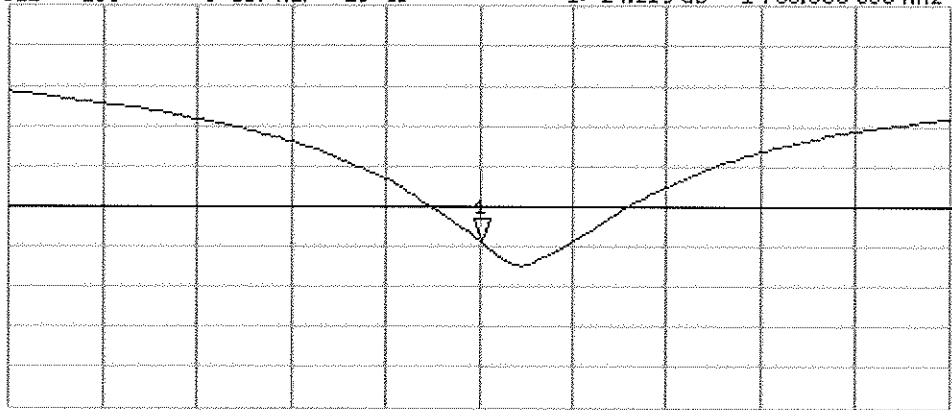

CENTER 1 765.000 000 MHz

SPAN 400.000 000 MHz