



RADIO TEST REPORT

Test Report No. : 33AE0113-HO-A

Applicant : SAMSUNG ELECTRONICS CO., LTD.
Type of Equipment : GPRS850/1900, EDGE850/1900, WCDMA2, WCDMA4, WCDMA5, LTE4, LTE17 Tablet with 802.11bgn, BT(EDR, LE)
Model No. : SGH-T779
Test standard : FCC Part 27 Subpart C: 2012
FCC ID : A3LSGHT779
Test Result : Complied

1. This test report shall not be reproduced in full or partial, without the written approval of UL Japan, Inc.
2. The results in this report apply only to the sample tested.
3. This sample tested is in compliance with above regulation.
4. The test results in this report are traceable to the national or international standards.
5. This test report must not be used by the customer to claim product certification, approval, or endorsement by NVLAP, NIST, or any agency of the Federal Government.

Date of test: August 23 to 31, 2012

Representative test engineer: 
Katsunori Okai
Engineer of WiSE Japan,
UL Verification Service

Approved by: 
Takahiro Hatakeda
Leader of WiSE Japan,
UL Verification Service



NVLAP LAB CODE: 200572-0

This laboratory is accredited by the NVLAP LAB CODE 200572-0, U.S.A. The tests reported herein have been performed in accordance with its terms of accreditation. *As for the range of Accreditation in NVLAP, you may refer to the WEB address, <http://www.ul.com/japan/jpn/pages/services/emc/about/mark1/index.jsp#nvlap>

UL Japan, Inc.

Head Office EMC Lab.

4383-326 Asama-cho, Ise-shi, Mie-ken 516-0021 JAPAN

Telephone : +81 596 24 8116

Facsimile : +81 596 24 8124

13-EM-F0429

| CONTENTS | PAGE |
|--|-------------|
| SECTION 1: Customer information | 3 |
| SECTION 2: Equipment under test (E.U.T.) | 3 |
| SECTION 3: Test specification, procedures & results | 5 |
| SECTION 4: Operation of E.U.T. during testing..... | 8 |
| SECTION 5: RF Output Power (Conducted/Radiated)..... | 14 |
| SECTION 6: Bandwidth (Conducted) | 15 |
| SECTION 7: Spurious Emission and Band-Edge (Conducted/Radiated) | 15 |
| SECTION 8: Frequency Stability(Temperature/Voltage Variation)..... | 16 |
| APPENDIX 1: Data of EMI test | 17 |
| RF Output Power (Conducted)..... | 17 |
| RF Output Power (Radiated)..... | 18 |
| Peak to Average power Ratio (Conducted) | 19 |
| Bandwidth(Conducted) | 21 |
| Band-Edge(Conducted) | 22 |
| Band Edge (Radiated)..... | 23 |
| Spurious Emission (Radiated) | 28 |
| Frequency Stability(Temperature/Voltage Variation)..... | 29 |
| APPENDIX 3: Test instruments | 30 |
| APPENDIX3: Photographs of test setup..... | 31 |
| Radiated Spurious Emission | 31 |
| Worst Case Position | 32 |

SECTION 1: Customer information

Company Name : SAMSUNG ELECTRONICS CO., LTD.
Address : 416, MAETAN 3-DONG, YEONGTONG-GU SUWON-CITY,
GYEONGGI-DO 443-742, SOUTH KOREA

SECTION 2: Equipment under test (E.U.T.)

2.1 Identification of E.U.T.

Type of Equipment : GPRS850/1900, EDGE850/1900, WCDMA2, WCDMA4, WCDMA5,
LTE4, LTE17 Tablet with 802.11bgn, BT(EDR, LE)
Model No. : SGH-T779
Serial No. : Refer to Section 4, Clause 4.2
Rating : DC5.0V(USB Power Supply)
DC3.7V/7000mAh, 25.9Wh
Receipt Date of Sample : August 23, 2012
Modification of EUT : No Modification by the test lab

2.2 Product Description

Radio Specification

Bluetooth

| | |
|-----------------------------|----------------|
| Equipment Type | Transceiver |
| Frequency of Operation | 2402-2480MHz |
| Type of Modulation | FHSS |
| Bandwidth & Channel spacing | 1MHz & 1MHz |
| Antenna Type | PIFA |
| Antenna Gain | -4.8 dBi (MAX) |

Low Energy

| | |
|-----------------------------|----------------|
| Equipment Type | Transceiver |
| Frequency of Operation | 2402-2480MHz |
| Type of Modulation | DSSS, FHSS |
| Bandwidth & Channel spacing | 1MHz & 2MHz |
| Antenna Type | PIFA |
| Antenna Gain | -4.8 dBi (MAX) |

WLAN (IEEE802.11b/g/n-20)

| | |
|-----------------------------|----------------|
| Equipment Type | Transceiver |
| Frequency of Operation | 2412-2462MHz |
| Type of Modulation | DSSS, OFDM |
| Bandwidth & Channel spacing | 20MHz & 5MHz |
| Antenna Type | PIFA |
| Antenna Gain | -4.8 dBi (MAX) |

UL Japan, Inc.

Head Office EMC Lab.

4383-326 Asama-cho, Ise-shi, Mie-ken 516-0021 JAPAN

Telephone : +81 596 24 8116

Facsimile : +81 596 24 8124

GSM

| | |
|------------------------|---|
| Equipment Type | Transceiver |
| Frequency of Operation | [Up Link] GSM850: 824 – 849MHz PCS: 1850 – 1910MHz [Down Link] GSM850: 869 – 894MHz PCS: 1930 – 1990MHz |
| Type of Modulation | GMSK , 8PSK |
| Emission Designator | GSM850: 249KGXW, 248KG7W PCS: 248KGXW, 248KG7W |
| Antenna Type | PIFA |
| Antenna Gain | GSM850: 824-849MHz: -5.73dBi (MAX) 869-894MHz: -5.83dBi (MAX) PCS: 1850-1910MHz: -5.62dBi (MAX) 1930-1990MHz: -5.51dBi (MAX) |

W-CDMA

| | |
|------------------------|--|
| Equipment Type | Transceiver |
| Frequency of Operation | [Up Link] Band V: 824 – 849MHz Band IV: 1710-1755MHz Band II: 1850 – 1910MHz [Down Link] Band V: 869 – 894MHz Band IV: 2110-2155MHz Band II: 1930 – 1990MHz |
| Type of Modulation | QPSK |
| Emission Designator | Band V: 4M16F9W Band II: 4M14F9W Band IV: 4M16F9W |
| Antenna Type | PIFA |
| Antenna Gain | Band V: 824-849MHz: -5.73dBi (MAX) 869-894MHz: -5.83dBi (MAX) Band IV: 1710-1755MHz: -6.64dBi (MAX) 2110-2155MHz: -6.78dBi (MAX) Band II: 1850-1910MHz: -5.62dBi (MAX) 1930-1900MHz: -5.51dBi (MAX) |

LTE

| | |
|------------------------|---|
| Equipment Type | Transceiver |
| Frequency of Operation | [Up Link] Band IV: 1710 – 1755MHz Band X VII: 704 – 716MHz [Down Link] Band IV: 2110 – 2155MHz Band X VII: 734 – 746MHz |
| Type of Modulation | QPSK, 16QAM |
| Emission Designator | Band IV: 4M53G7D, 4M52W7D, 8M97G7D, 8M96W7D, 13M5G7D, 13M5W7D, 17M9G7D, 17M9W7D Band X VII: 4M53G7D, 4M51W7D, 8M96G7D, 8M98W7D |
| Antenna Type | PIFA |
| Antenna Gain | Band IV: 1710-1755MHz: -5.57dBi (MAX) 2110-2155MHz: -3.86dBi (MAX) Band X VII: 704-716MHz: -5.95dBi (MAX) 734-746MHz: -4.23dBi (MAX) |

UL Japan, Inc.

Head Office EMC Lab.

4383-326 Asama-cho, Ise-shi, Mie-ken 516-0021 JAPAN

Telephone : +81 596 24 8116

Facsimile : +81 596 24 8124

SECTION 3: Test specification, procedures & results

3.1 Test Specification

Test Specification : FCC Part 27 Subpart C: 2010, final revised on January 26, 2012

Title : FCC 47CFR Part 27 Subpart C Technical Standards
MISCELLANEOUS WIRELESS COMMUNICATIONS SERVICES

*The EUT is a variant model of model No.SGH-I497 (FCC ID: A3LSGHI497), and the hardware is identical between two models. The only difference is adding in the WCDMA Band 4, enabled by software. This report includes the test result for WCDMA Band 4 only.

3.2 Procedures and results

| Item | Test Specification & Procedure | Remarks | Deviation | Worst margin | Results |
|---|---|------------------------|------------------|---|----------------|
| RF Output Power(Conducted/ Radiated) (Conducted Output Power / Equivalent isotropic radiated power(EIRP)) | FCC 2.1046 FCC 27.50 | Conducted/ Radiated | N/A | - | Complied |
| Peak to Average power Ratio | FCC 27.50 | Conducted | N/A | - | Complied |
| Emission Bandwidth, 99% Occupied Bandwidth | FCC 2.1049 | Conducted | N/A | - | Complied |
| Band-Edge | FCC 2.1051 FCC 2.1053 FCC 27.53 | Conducted/ Radiated | N/A | [Conducted] 5.31dB 1710MHz [Radiated] 3.8dB 1710MHz, Horizontal | Complied |
| Spurious Emission(Conducted) | FCC 2.1051 FCC 27.53 | Conducted | N/A | - | Complied |
| Spurious Emission(Radiated) | FCC 2.1053 FCC 27.53 | Radiated | N/A | 31.2dB 3505.2MHz, Vertical | Complied |
| Frequency Stability (Temperature Variation/ Voltage Variation) | FCC 2.1055 FCC 27.54 | Conducted | N/A | - | Complied |
| Note: UL Japan's EMI Work Procedures No. 13-EM-W0420 | | | | | |

*These tests were also referred to ANSI/TIA 603-C-2004 "Land Mobile FM or PM Communications Equipment Measurement and Performance Standards."

*These tests were performed without any deviations from test procedure except for additions or exclusions.

UL Japan, Inc.

Head Office EMC Lab.

4383-326 Asama-cho, Ise-shi, Mie-ken 516-0021 JAPAN

Telephone : +81 596 24 8116

Facsimile : +81 596 24 8124

3.3 Uncertainty

EMI

The following uncertainties have been calculated to provide a confidence level of 95% using a coverage factor k=2.

| Radiated Emission (EUT height: 0.8m) (+dB) | |
|--|-------|
| Measurement Distance 3m | |
| 30MHz-300MHz | 5.5dB |
| 300MHz-1000MHz | 4.2dB |
| 1GHz-12.75GHz | 4.6dB |

| Power meter (+dB) | |
|-------------------|------------|
| Below 1GHz | Above 1GHz |
| 1.0dB | 1.0dB |

| Antenna terminal conducted emission and Power density (+dB) | | | Antenna terminal conducted emission (+dB) | | Channel power (+dB) |
|---|-----------|------------|---|---------------|---------------------|
| Below 1GHz | 1GHz-3GHz | 3GHz-18GHz | 18GHz-26.5GHz | 26.5GHz-40GHz | |
| 1.0dB | 1.1dB | 2.7dB | 3.2dB | 3.3dB | 1.5dB |

Antenna Terminal Conducted emission test

The data listed in this report has enough margin, more than the site margin.

Radiated emission test(3m)

The data listed in this report meets the limits unless the uncertainty is taken into consideration.

UL Japan, Inc.

Head Office EMC Lab.

4383-326 Asama-cho, Ise-shi, Mie-ken 516-0021 JAPAN

Telephone : +81 596 24 8116

Facsimile : +81 596 24 8124

3.4 Test Location

UL Japan, Inc. Head Office EMC Lab. *NVLAP Lab. code: 200572-0
4383-326 Asama-cho, Ise-shi, Mie-ken 516-0021 JAPAN
Telephone : +81 596 24 8116 Facsimile : +81 596 24 8124

| | FCC Registration Number | IC Registration Number | Width x Depth x Height (m) | Size of reference ground plane (m) / horizontal conducting plane | Other rooms |
|----------------------------|-------------------------|------------------------|----------------------------|--|------------------------|
| No.1 semi-anechoic chamber | 313583 | 2973C-1 | 19.2 x 11.2 x 7.7m | 7.0 x 6.0m | No.1 Power source room |
| No.2 semi-anechoic chamber | 655103 | 2973C-2 | 7.5 x 5.8 x 5.2m | 4.0 x 4.0m | - |
| No.3 semi-anechoic chamber | 148738 | 2973C-3 | 12.0 x 8.5 x 5.9m | 6.8 x 5.75m | No.3 Preparation room |
| No.3 shielded room | - | - | 4.0 x 6.0 x 2.7m | N/A | - |
| No.4 semi-anechoic chamber | 134570 | 2973C-4 | 12.0 x 8.5 x 5.9m | 6.8 x 5.75m | No.4 Preparation room |
| No.4 shielded room | - | - | 4.0 x 6.0 x 2.7m | N/A | - |
| No.5 semi-anechoic chamber | - | - | 6.0 x 6.0 x 3.9m | 6.0 x 6.0m | - |
| No.6 shielded room | - | - | 4.0 x 4.5 x 2.7m | 4.75 x 5.4 m | - |
| No.6 measurement room | - | - | 4.75 x 5.4 x 3.0m | 4.75 x 4.15 m | - |
| No.7 shielded room | - | - | 4.7 x 7.5 x 2.7m | 4.7 x 7.5m | - |
| No.8 measurement room | - | - | 3.1 x 5.0 x 2.7m | N/A | - |
| No.9 measurement room | - | - | 8.0 x 4.5 x 2.8m | 2.0 x 2.0m | - |
| No.10 measurement room | - | - | 2.6 x 2.8 x 2.5m | 2.4 x 2.4m | - |
| No.11 measurement room | - | - | 3.1 x 3.4 x 3.0m | 2.4 x 3.4m | - |

* Size of vertical conducting plane (for Conducted Emission test): 2.0 x 2.0m for No.1, No.2, No.3, and No.4 semi-anechoic chambers and No.3 and No.4 shielded rooms.

3.5 Test set up, Test instruments and Data of EMI

Refer to APPENDIX.

SECTION 4: Operation of E.U.T. during testing

4.1 Operating Modes

| Test | Operating mode | Power Control | Tested frequency | Channel |
|---|--|-----------------------|--|----------------------|
| RF output Power(Conducted) | Transmitting (Tx) W-CDMA (RMC12.2kbps) Transmitting (Tx) W-CDMA (HSDPA Subtest 1-4) Transmitting (Tx) W-CDMA (HSUPA Subtest 1-5) | See Section 4.1.1 | 1712.4 MHz 1732.6 MHz 1752.6 MHz | 1312 1413 1513 |
| RF output Power (Radiated), Spurious Emission (Conducted/Radiated), Peak to Average power Ratio (Conducted) | Transmitting (Tx) W-CDMA (RMC12.2kbps) | TPC All Up bits(Max) | 1712.4 MHz 1732.6 MHz 1752.6 MHz | 1312 1413 1513 |
| Peak to Average power Ratio (Conducted) | Transmitting (Tx) W-CDMA (RMC12.2kbps) | TPC All Up bits(Max) | 1712.4 MHz 1732.6 MHz 1752.6 MHz | 1312 1413 1513 |
| Band Edge (Conducted/Radiated) | Transmitting (Tx) W-CDMA (RMC12.2kbps) | TPC All Up bits(Max) | 1712.4 MHz 1752.6 MHz | 1312 1513 |
| Emission Bandwidth, 99% Occupied bandwidth, Frequency Stability (Temperature/Voltage Variation) | Transmitting (Tx) W-CDMA (RMC12.2kbps) | TPC all up bits (MAX) | 1732.6 MHz | 1413 |

*The WCDMA and HSPA modes of EUT were verified on each channel and "sub-tests" according to section 4.1.1. (Also refer to Release-6 procedures in section 5.2 of 3GPP TS 34.121.)

4.1.1 Explanation of the Rel-99 WCDMA and Rel-6 HSPA measurement mode

3GPP defines UE Test Modes and Channel Configurations for Regulatory Testing.

- **UE Test Modes:**
Test Mode 1(Data Loopback Test)
- **Channel Configurations:**
R99 – 12.2kpbs Reference Measurement Channel (RMC) channel
HSDPA – Fixed Reference Channel (FRC)
HSUPA – New HSUPA channel configuration (HSDPA data from DL is looped back onto UL)
- **Procedure to configure UE to transmit maximum power:**
Rel99: 3GPP TS 34.121 section 5.2
HSDPA Rel5: 3GPP TS 34.121 section 5.2A
HSDPA Rel6: 3GPP TS 34.121 section 5.2AA
HSUPA Rel6: 3GPP TS 34.121 section 5.2B

* About Rel-99 and HSDPA testing, test equipment send “all up bits” forcing UE max power

(1) Explanation for HSDPA/HSPA Subtests

3GPP TS 34.121 defines test requirements and procedures for testing all variations of WCDMA. 3GPP TS 34.121 defines 4 HSDPA test configurations and 5 HSPA test configurations (“Subtests”) for various RF Conformance tests. The Following table shows Release 5 HSDPA and Release 6 HSPA Subtest Configurations per 3GPP TS 34.121.

[HSDPA]

Table C.10.1.4: β values for transmitter characteristics tests with HS-DPCCH

| Sub-test | β_c | β_d | β_d (SF) | β_c/β_d | β_{HS} (Note 1, Note 2) | CM (dB) (Note 3) | MPR (dB) (Note 3) |
|----------|-----------|-----------|-------------------|-------------------|-------------------------------------|---------------------|----------------------|
| 1 | 2/15 | 15/15 | 64 | 2/15 | 4/15 | 0.0 | 0.0 |
| 2 | 12/15 | 15/15 | 64 | 12/15 | 24/15 | 1.0 | 0.0 |
| | (Note 4) | (Note 4) | | (Note 4) | | | |
| 3 | 15/15 | 8/15 | 64 | 15/8 | 30/15 | 1.5 | 0.5 |
| 4 | 15/15 | 4/15 | 64 | 15/4 | 30/15 | 1.5 | 0.5 |

Note 1: Δ_{ACK} , Δ_{NACK} and $\Delta_{CQI} = 30/15$ with $\beta_{HS} = 30/15 * \beta_c$.

Note 2: For the HS-DPCCH power mask requirement test in clause 5.2C, 5.7A, and the Error Vector Magnitude (EVM) with HS-DPCCH test in clause 5.13.1A, and HSDPA EVM with phase discontinuity in clause 5.13.1AA, Δ_{ACK} and $\Delta_{NACK} = 30/15$ with $\beta_{HS} = 30/15 * \beta_c$, and $\Delta_{CQI} = 24/15$ with $\beta_{HS} = 24/15 * \beta_c$.

Note 3: CM = 1 for $\beta_c/\beta_d = 12/15$, $\beta_{HS}/\beta_c = 24/15$. For all other combinations of DPDCH, DPCCH and HS-DPCCH the MPR is based on the relative CM difference. This is applicable for only UEs that support HSDPA in release 6 and later releases.

Note 4: For subtest 2 the β_c/β_d ratio of 12/15 for the TFC during the measurement period (TF1, TF0) is achieved by setting the signalled gain factors for the reference TFC (TF1, TF1) to $\beta_c = 11/15$ and $\beta_d = 15/15$.

UL Japan, Inc.

Head Office EMC Lab.

4383-326 Asama-cho, Ise-shi, Mie-ken 516-0021 JAPAN

Telephone : +81 596 24 8116

Facsimile : +81 596 24 8124

[HSUPA]

Table C.11.1.3: β values for transmitter characteristics tests with HS-DPCCH and E-DCH

| Sub-test | β_c | β_d | β_d (SF) | β_c/β_d | β_{HS} (Note 1) | β_{oc} | β_{ed} (Note 5) (Note 6) | β_{ed} (SF) | β_{ed} (Codes) | CM (dB) (Note 2) | MPR (dB) (Note 2) | AG Index (Note 6) | E- TFCI |
|----------|-------------------|-------------------|-------------------|-------------------|--------------------------|--------------|--|----------------------|-------------------------|------------------------|-------------------------|-------------------------|------------|
| 1 | 11/15 (Note 3) | 15/15 (Note 3) | 64 | 11/15 (Note 3) | 22/15 | 209/225 | 1309/225 | 4 | 1 | 1.0 | 0.0 | 20 | 75 |
| 2 | 6/15 | 15/15 | 64 | 6/15 | 12/15 | 12/15 | 94/75 | 4 | 1 | 3.0 | 2.0 | 12 | 67 |
| 3 | 15/15 | 9/15 | 64 | 15/9 | 30/15 | 30/15 | β_{ed1} : 47/15 β_{ed2} : 47/15 | 4 | 2 | 2.0 | 1.0 | 15 | 92 |
| 4 | 2/15 | 15/15 | 64 | 2/15 | 4/15 | 2/15 | 56/75 | 4 | 1 | 3.0 | 2.0 | 17 | 71 |
| 5 | 15/15 (Note 4) | 15/15 (Note 4) | 64 | 15/15 (Note 4) | 30/15 | 24/15 | 134/15 | 4 | 1 | 1.0 | 0.0 | 21 | 81 |

Note 1: Δ_{ACK} , Δ_{NACK} and $\Delta_{CQI} = 30/15$ with $\beta_{hs} = 30/15 * \beta_c$.

Note 2: CM = 1 for $\beta_c/\beta_d = 12/15$, $\beta_{ed}/\beta_c = 24/15$. For all other combinations of DPDCH, DPCCH, HS-DPCCH, E-DPDCH and E-DPCCH the MPR is based on the relative CM difference.

Note 3: For subtest 1 the β_c/β_d ratio of 11/15 for the TFC during the measurement period (TF1, TF0) is achieved by setting the signalled gain factors for the reference TFC (TF1, TF1) to $\beta_c = 10/15$ and $\beta_d = 15/15$.

Note 4: For subtest 5 the β_c/β_d ratio of 15/15 for the TFC during the measurement period (TF1, TF0) is achieved by setting the signalled gain factors for the reference TFC (TF1, TF1) to $\beta_c = 14/15$ and $\beta_d = 15/15$.

Note 5: In case of testing by UE using E-DPDCH Physical Layer category 1, Sub-test 3 is omitted according to TS25.306 Table 5.1g.

Note 6: β_{ed} can not be set directly, it is set by Absolute Grant Value.

(2) Maximum Output Power Verification

[HSDPA]

Maximum output power was verified on High, Middle and Low channels according to the Release 5 procedures described in section 5.2 of 3GPP TS 34.121, using an FRC with H-set 1 and 12.2kbps RMC with TPC (transmit power control) set to all "1's". Output power was measured according requirements for HS-DPCCH Sub-test 1-4.

[HSUPA]

Maximum output power was verified on the High, Middle and Low channels according to Release 6 procedures in section 5.2 of 3GPP TS 34.121, using the appropriate RMC, FRC and E-DCH configurations. When E-DCH was active, inner loop power control with power control algorithm 2 was used to maintain E-TFCI requirements. Output power for the applicable HSPA modes was measured for E-DCH Sub-test 1-5.

UL Japan, Inc.

Head Office EMC Lab.

4383-326 Asama-cho, Ise-shi, Mie-ken 516-0021 JAPAN

Telephone : +81 596 24 8116

Facsimile : +81 596 24 8124

(3) Test Equipment Setting Summary Table

The following table is the key parameters that was configured in test equipment.

| Subtest | Mode | Loopback Mode | Rel99 RMC | HSDPA FRC | HSUPA Test | Common Setting | | β_c/β_d | MPR | Power Class 3 limit |
|---------|------------|---------------|--------------|----------------|----------------|----------------|-----------|-------------------|-----|---------------------|
| | | | | | | β_c | β_d | | | |
| | Rel99 | Test Mode 1 | 12.2kbps RMC | - | - | - | - | 8/15 | - | 24(+1.7/-3.7dB) |
| 1 | Rel6 HSDPA | Test Mode 1 | 12.2kbps RMC | H-Set 1 (QPSK) | - | 2/15 | 15/15 | 2/15 | 0 | 24(+1.7/-3.7dB) |
| 2 | Rel6 HSDPA | Test Mode 1 | 12.2kbps RMC | H-Set 1 (QPSK) | - | 12/15 | 15/15 | 12/15 | 0 | 24(+1.7/-3.7dB) |
| 3 | Rel6 HSDPA | Test Mode 1 | 12.2kbps RMC | H-Set 1 (QPSK) | - | 15/15 | 8/15 | 15/8 | 0.5 | 23.5(+2.2/-3.7dB) |
| 4 | Rel6 HSDPA | Test Mode 1 | 12.2kbps RMC | H-Set 1 (QPSK) | - | 15/15 | 4/15 | 15/4 | 0.5 | 23.5(+2.2/-3.7dB) |
| 1 | Rel6 HSUPA | Test Mode 1 | 12.2kbps RMC | H-Set 1 (QPSK) | HSUPA Loopback | 11/15 | 15/15 | 11/15 | 0 | 24(+1.7/-3.7dB) |
| 2 | Rel6 HSUPA | Test Mode 1 | 12.2kbps RMC | H-Set 1 (QPSK) | HSUPA Loopback | 6/15 | 15/15 | 6/15 | 2 | 22(+3.7/-3.7dB) |
| 3 | Rel6 HSUPA | Test Mode 1 | 12.2kbps RMC | H-Set 1 (QPSK) | HSUPA Loopback | 15/15 | 9/15 | 15/9 | 1 | 23(+2.7/-3.7dB) |
| 4 | Rel6 HSUPA | Test Mode 1 | 12.2kbps RMC | H-Set 1 (QPSK) | HSUPA Loopback | 2/15 | 15/15 | 2/15 | 2 | 22(+3.7/-3.7dB) |
| 5 | Rel6 HSUPA | Test Mode 1 | 12.2kbps RMC | H-Set 1 (QPSK) | HSUPA Loopback | 15/15 | 15/15 | 15/15 | 0 | 24(+1.7/-3.7dB) |

| Subtest | HSDPA Specific Settings | | | | | | |
|-------------|-------------------------|---------------|--------------|----------------------------|--------------|-----------------------|----------------------------|
| | Δ ACK | Δ NACK | Δ CQI | Ack-Nack repetition factor | CQI Feedback | CQI Repetition Factor | Ahs= β hs/ β c |
| Rel 6 HSDPA | | | | | | | |
| 1 | 8 | 8 | 8 | 3 | 4ms | 2 | 30/15 |
| 2 | 8 | 8 | 8 | 3 | 4ms | 2 | 30/15 |
| 3 | 8 | 8 | 8 | 3 | 4ms | 2 | 30/15 |
| 4 | 8 | 8 | 8 | 3 | 4ms | 2 | 30/15 |

| Subtest | HSDPA Specific Settings | | | | | | | HSUPA Specific Settings | | | HSUPA Additional Info | |
|------------|-------------------------|---------------|--------------|----------------------------|--------------|-----------------------|----------------------------|-------------------------|---------------|----------|--------------------------------------|----------------------------------|
| | Δ ACK | Δ NACK | Δ CQI | Ack-Nack repetition factor | CQI Feedback | CQI Repetition Factor | Ahs= β hs/ β c | Δ E-DPCCH | Δ HARQ | AG Index | ETFCI (form TS34.121 Table C.11.1.3) | Associated Max UL Data Rate kbps |
| Rel 6 HSPA | | | | | | | | | | | | |
| 1 | 8 | 8 | 8 | 3 | 4ms | 2 | 30/15 | 6 | 0 | 20 | 75 | 242.1 |
| 2 | 8 | 8 | 8 | 3 | 4ms | 2 | 30/15 | 8 | 0 | 12 | 67 | 174.9 |
| 3 | 8 | 8 | 8 | 3 | 4ms | 2 | 30/15 | 8 | 0 | 15 | 92 | 482.8 |
| 4 | 8 | 8 | 8 | 3 | 4ms | 2 | 30/15 | 5 | 0 | 17 | 71 | 205.8 |
| 5 | 8 | 8 | 8 | 3 | 4ms | 2 | 30/15 | 7 | 0 | 21 | 81 | 308.9 |

HSUPA Reference E-TFCI Parameters
[Subtest 1, 2, 4, 5]

| Information Element | Value/Remark |
|-----------------------|------------------|
| E-DCH info | Uplink DPCH info |
| - E-DPDCH info | |
| - Reference E-TFCIs | 5 E-TFCIs |
| - Reference E-TFCI | 11 |
| - Reference E-TFCI PO | 4 |
| - Reference E-TFCI | 67 |
| - Reference E-TFCI PO | 18 |
| - Reference E-TFCI | 71 |
| - Reference E-TFCI PO | 23 |
| - Reference E-TFCI | 75 |
| - Reference E-TFCI PO | 26 |
| - Reference E-TFCI | 81 |
| - Reference E-TFCI PO | 27 |

[Subtest 3]

| Information Element | Value/Remark |
|-----------------------|------------------|
| E-DCH info | Uplink DPCH info |
| - E-DPDCH info | |
| - Reference E-TFCIs | 2 E-TFCIs |
| - Reference E-TFCI | 11 |
| - Reference E-TFCI PO | 4 |
| - Reference E-TFCI | 92 |
| - Reference E-TFCI PO | 18 |

4.2 Configuration and peripherals

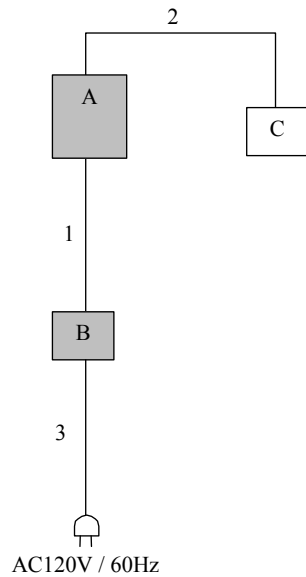

* Cabling and setup(s) were taken into consideration and test data was taken under worse case conditions.

Description of EUT and Support equipment

| No. | Item | Model number | Serial number | Manufacturer | Remarks |
|-----|--|--------------|--|--------------|---------|
| A | GPRS850/1900, EDGE850/1900, WCDMA2, WCDMA4, WCDMA5, LTE4, LTE17 Tablet with 802.11bgn, BT(EDR, LE) | SGH-T779 | 354414050001143*1) 354414050001135*2) | SAMSUNG | EUT |
| B | AC Adapter | ETA-P11X | - | SAMSUNG | EUT |
| C | Ear phone | - | - | SAMSUNG | - |

*1) Antenna Terminal Conducted test

*2) Radiated Emission test

List of cables used

| No. | Name | Length (m) | Shield | | Remarks |
|-----|-----------------|------------|------------|------------|---------|
| | | | Cable | Connector | |
| 1 | USB Cable | 1.0 | Shielded | Shielded | - |
| 2 | Ear phone Cable | 1.2 | Unshielded | Unshielded | - |
| 3 | AC Cable | 0.9 | Unshielded | Unshielded | - |

UL Japan, Inc.

Head Office EMC Lab.

4383-326 Asama-cho, Ise-shi, Mie-ken 516-0021 JAPAN

Telephone : +81 596 24 8116

Facsimile : +81 596 24 8124

SECTION 5: RF Output Power (Conducted/Radiated)

[Conducted: Conducted Output Power]

Test Procedure

The RF output power (conducted) was measured with a Wireless Communication Test Set and an attenuator at the antenna port.

[Radiated : Equivalent isotropic radiated power(EIRP)]

Test Procedure

- 1) EUT was placed on a platform of nominal size, 0.5 m by 1.0m, raised 80cm above the conducting ground plane. Test was made with the antenna positioned in both the horizontal and vertical planes of polarization. The Radiated Electric Field Strength intensity has been measured in a semi anechoic chamber with a ground plane and at a distance of 3m.
The measuring antenna height varied between 1 and 4m and EUT was rotated a full revolution in order to obtain the maximum value of the electric field intensity.
- 2) Exchanged the EUT to the Substitution Antenna, the antenna was set for the same height as EUT on the table. Horn antenna calibrated with the Half wave dipole antenna was used as a substitution antenna for testing at the frequency above 1GHz, which is harmonized with the measured frequency in 1).
The Substitution Antenna was connected with the Signal Generator, and the polarized electromagnetic radiation of the Substitution Antenna was matched with the one of the measuring Antenna, which was set with the Signal Generator to the measured frequency in 1). Then, we set with the Output power (CW) of the Signal Generator where the measuring electromagnetic field is equal to the measured value in 1).
The measuring antenna height varied between 1 and 4m to obtain the maximum receiving level.
Its Output power of Signal Generator was recorded.
- 3) Equivalent isotropic radiated power(EIRP) was calculated by subtracting the cable loss and the attenuator loss connected between the Signal Generator and the Substitution Antenna from the Output power of the Signal Generator recorded in 2).

- The carrier level and noise levels were confirmed at each position of X, Y and Z axis of EUT to see the position of maximum noise, and the test was made at the position that has the maximum noise.

Test data : **APPENDIX 1**
Test result : **Pass**

SECTION 6: Bandwidth (Conducted)

Test Procedure

The Emission Bandwidth and 99% Occupied Bandwidth was measured with a spectrum analyzer and attenuator connected to the antenna port.

Test data : **APPENDIX 1**
Test result : **Pass**

SECTION 7: Spurious Emission and Band-Edge (Conducted/Radiated)

[Conducted]

Test Procedure

The Spurious Emission and Band-Edge was measured with a spectrum analyzer and attenuator connected to the antenna port.

[Radiated]

Test Procedure

- 1) EUT was placed on a platform of nominal size, 0.5m by 1.0m, raised 80cm above the conducting ground plane. Test was made with the antenna positioned in both the horizontal and vertical planes of polarization. The Radiated Electric Field Strength intensity has been measured in a semi anechoic chamber with a ground plane and at a distance of 3m. The measuring antenna height varied between 1 and 4m and EUT was rotated a full revolution in order to obtain the maximum value of the electric field intensity.
- 2) Exchanged the EUT to the Substitution Antenna, the antenna was set for the same height as EUT on the table. Half wave dipole antenna was used as a substitution antenna for testing at the frequency below 1GHz, which is harmonized with the measured frequency in 1). Horn antenna calibrated with the Half wave dipole antenna was used as a substitution antenna for testing at the frequency above 1GHz, which is harmonized with the measured frequency in 1). The Substitution antenna was connected with the Signal Generator, and the polarized electromagnetic radiation of the Substitution antenna was matched with the one of the measuring antenna, which was set with the Signal Generator to the measured frequency in 1). Then, we set with the Output power (CW) of the Signal Generator where the measuring electromagnetic field is equal to the measured value in 1). The measuring antenna height varied between 1 and 4m to obtain the maximum receiving level. Its Output power of Signal Generator was recorded.
- 3) Equivalent isotropic radiated power(EIRP) was calculated by subtracting the cable loss and the attenuator loss connected between the Signal Generator and the Substitution Antenna from the Output power of the Signal Generator recorded in 2).

- The carrier level and noise levels were confirmed at each position of X, Y and Z axis of EUT to see the position of maximum noise, and the test was made at the position that has the maximum noise.

Test data : **APPENDIX 1**
Test result : **Pass**

UL Japan, Inc.

Head Office EMC Lab.

4383-326 Asama-cho, Ise-shi, Mie-ken 516-0021 JAPAN

Telephone : +81 596 24 8116

Facsimile : +81 596 24 8124

SECTION 8: Frequency Stability(Temperature/Voltage Variation)

Test Procedure

The Frequency Stability was measured with a Radio Communication Analyzer and attenuator connected to the antenna port.

The Frequency Drift was measured with the 10 deg. C. steps from -30 deg. C. to 50 deg. C., and it is presented as the ppm unit. The Frequency Drift was measured with the normal temperature (20 deg. C.) and Voltage tolerance (DC 3.6V to DC 4.2V), and it is presented as the ppm unit.

Temperature : -30deg.C to +50deg.C (10 deg. C. step)
Voltage : Vnom:DC3.7V, Vmin:DC3.6V, Vmax:DC4.2V

As the operating input voltage of the EUT is between DC 3.6V to DC 4.2V (nominal voltage: DC 3.7V), Frequency Stability test was performed under the above condition.

Test data : **APPENDIX 1**
Test result : **Pass**

APPENDIX 1: Data of EMI test

RF Output Power (Conducted)
Conducted Output Power

Test place Head Office EMC Lab. No.6 Measurement Room
Report No. 33AE0113-HO
Date 08/27/2012
Temperature/ Humidity 24deg. C / 62% RH
Engineer Katsunori Okai
Mode Tx W-CDMA

| Mode | Ch | Frequency [MHz] | Reading AVG [dBm] | Cable Loss [dB] | Result [dBm] |
|--------------------|------|--------------------|-------------------------|-----------------------|-----------------|
| RMC 12.2kbps | Low | 1712.4 | 22.47 | 0.45 | 22.92 |
| | Mid | 1732.6 | 22.40 | 0.45 | 22.85 |
| | High | 1752.6 | 22.24 | 0.45 | 22.69 |
| HSDPA Subtest 1 | Low | 1712.4 | 21.47 | 0.45 | 21.92 |
| | Mid | 1732.6 | 21.41 | 0.45 | 21.86 |
| | High | 1752.6 | 21.34 | 0.45 | 21.79 |
| HSDPA Subtest 2 | Low | 1712.4 | 21.53 | 0.45 | 21.98 |
| | Mid | 1732.6 | 21.42 | 0.45 | 21.87 |
| | High | 1752.6 | 21.42 | 0.45 | 21.87 |
| HSDPA Subtest 3 | Low | 1712.4 | 21.01 | 0.45 | 21.46 |
| | Mid | 1732.6 | 20.96 | 0.45 | 21.41 |
| | High | 1752.6 | 20.91 | 0.45 | 21.36 |
| HSDPA Subtest 4 | Low | 1712.4 | 21.07 | 0.45 | 21.52 |
| | Mid | 1732.6 | 20.90 | 0.45 | 21.35 |
| | High | 1752.6 | 20.92 | 0.45 | 21.37 |
| HSUPA Subtest 1 | Low | 1712.4 | 20.43 | 0.45 | 20.88 |
| | Mid | 1732.6 | 21.46 | 0.45 | 21.91 |
| | High | 1752.6 | 21.25 | 0.45 | 21.70 |
| HSUPA Subtest 2 | Low | 1712.4 | 18.47 | 0.45 | 18.92 |
| | Mid | 1732.6 | 18.53 | 0.45 | 18.98 |
| | High | 1752.6 | 18.57 | 0.45 | 19.02 |
| HSUPA Subtest 3 | Low | 1712.4 | 20.46 | 0.45 | 20.91 |
| | Mid | 1732.6 | 19.90 | 0.45 | 20.35 |
| | High | 1752.6 | 19.91 | 0.45 | 20.36 |
| HSUPA Subtest 4 | Low | 1712.4 | 18.56 | 0.45 | 19.01 |
| | Mid | 1732.6 | 18.54 | 0.45 | 18.99 |
| | High | 1752.6 | 18.45 | 0.45 | 18.90 |
| HSUPA Subtest 5 | Low | 1712.4 | 21.43 | 0.45 | 21.88 |
| | Mid | 1732.6 | 21.31 | 0.45 | 21.76 |
| | High | 1752.6 | 21.21 | 0.45 | 21.66 |

Results = Reading + Cable Loss

*The enhanced power reduction may result in around 1dB of variance from the MPR target values depending on HSPA channel configuration (e.g. 34.121 subtest) and characteristics of hardware RF design.

RF Output Power (Radiated)
Equivalent Isotropically Radiated Power(EIRP)

Report No. 33AE0113-HO
Test place Head Office EMC Lab. No.2 Semi Anechoic Chamber
Date 08/31/2012
Temperature / Humidity 24 deg. C / 55 % RH
Engineer Katsunori Okai
Mode Tx W-CDMA (RMC12.2kbps), All Up Bits

| Frequency [MHz] | Rx SA/TR Reading [dBuV] | | Tx SG Reading [dBm] | | Tx Cable Loss [dB] | Tx Ant. Gain [dBi] | Tx Ant. Atten. Loss [dB] | Result (EIRP) [dBm] | | Limit (EIRP) [dBm] | Margin [dB] | | Horizontal | | Vertical | | Remarks | | |
|--------------------|-------------------------------|------|---------------------------|------|-----------------------------|-----------------------------|-----------------------------------|---------------------------|------|--------------------------|----------------|-----|------------|-----|----------|-------|---------|---------|-------|
| | HOR | VER | HOR | VER | | | | HOR | VER | | HOR | VER | HOR | VER | Rx Ant. | Turn | | Rx Ant. | Turn |
| | | | | | | | | | | | | | | | Height | Table | | Height | Table |
| 1712.40 | 97.1 | 96.7 | 22.9 | 20.8 | 4.3 | 9.5 | 0.0 | 28.1 | 26.0 | 30.0 | 1.9 | 4.0 | 103 | 312 | 110 | 306 | | | |
| 1732.60 | 98.4 | 97.3 | 24.2 | 21.2 | 4.4 | 9.6 | 0.0 | 29.4 | 26.4 | 30.0 | 0.6 | 3.6 | 100 | 307 | 108 | 306 | | | |
| 1752.60 | 97.5 | 96.6 | 23.3 | 20.6 | 4.4 | 9.6 | 0.0 | 28.5 | 25.8 | 30.0 | 1.5 | 4.2 | 100 | 304 | 107 | 308 | | | |

Calculation Result = SG Reading - Tx Cable Loss + Tx Antenna Gain - Tx Antenna Attenuator Loss

Rx-ANTENNA : Biconical Antenna(30M-300MHz), Logperiodic Antenna(300M-1000MHz), Horn Antenna(1G-20GHz)

Tx-ANTENNA : 120MHz tuned Dipole Antenna(30M-120MHz), Dipole Antenna(120M-1000MHz), Horn Antenna(1G-20GHz)

Detector : S/A PK (RBW: 5MHz , VBW: 50MHz)

Peak to Average power Ratio (Conducted)

Test place Head Office EMC Lab. No.6 Measurement Room
Report No. 33AE0113-HO
Date 08/23/2012
Temperature/ Humidity 23deg. C / 68% RH
Engineer Yutaka Yoshida
Mode Tx W-CDMA(RMC12.2kbps), All Up Bits

| Mode | Channel | Frequency [MHz] | Peak to Average Power Ratio [dB] | Limit [dB] |
|-----------|---------|--------------------|-------------------------------------|---------------|
| W-CDMA *) | 1312 | 1712.4 | 3.30 | 13 |
| | 1413 | 1732.6 | 3.23 | 13 |
| | 1513 | 1752.6 | 3.33 | 13 |

*In order to decide the largest deviation between the average and the peak power of the EUT in a bandwidth, Complementary Cumulative Distribution Function (CCDF) curves of the spectrum analyzer were used for W-CDMA Signals.

Peak to Average power Ratio (Conducted)

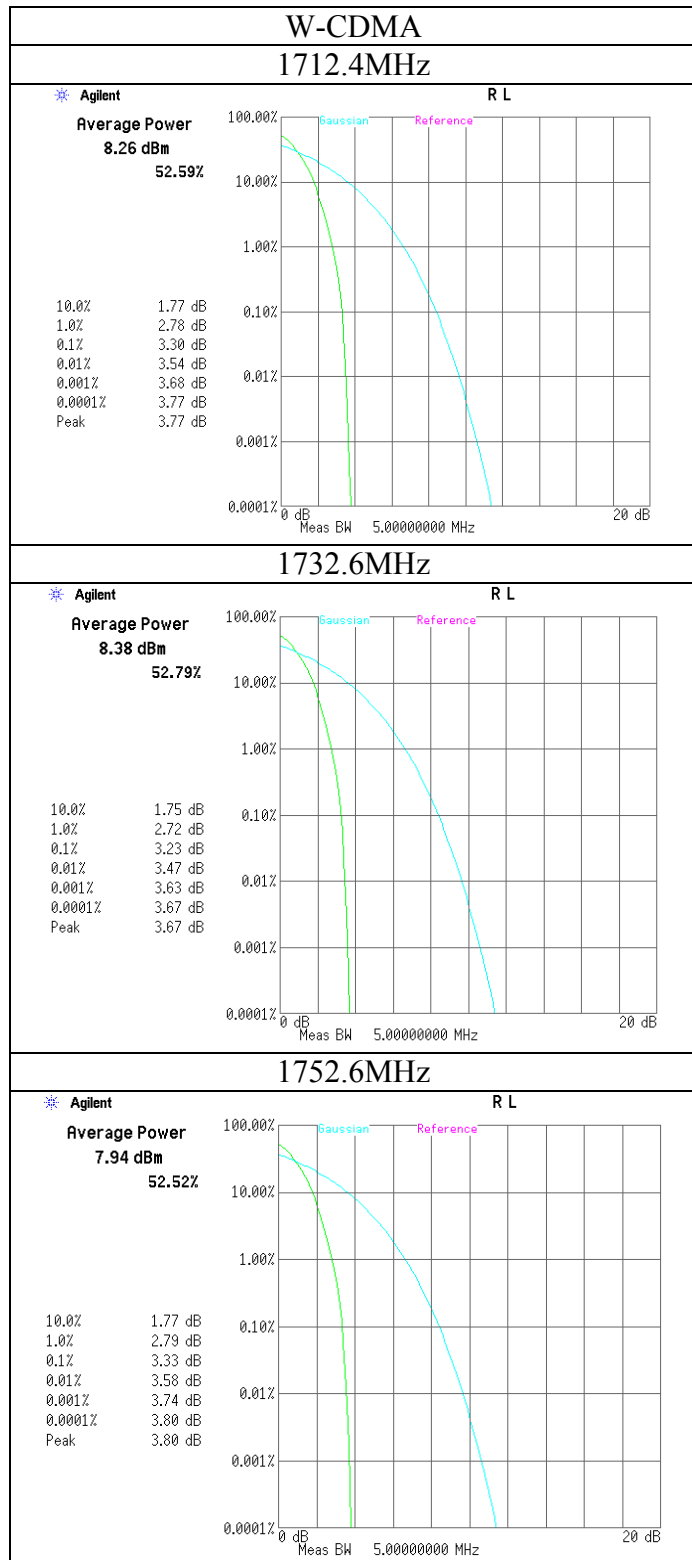

*Set the spectrum analyzer radio mode to 3GPP W-CDMA (Power Stat CCDF)

Bandwidth(Conducted)

| | |
|-----------------------|--|
| Test place | Head Office EMC Lab. No.6 Measurement Room |
| Report No. | 33AE0113-HO |
| Date | 08/23/2012 |
| Temperature/ Humidity | 23deg. C / 68% RH |
| Engineer | Yutaka Yoshida |
| Mode | Tx W-CDMA(RMC12.2kbps), All Up Bits |

| CH | FREQ | 26dB Bandwidth | 99% OBW | Limit |
|-----|--------|----------------|---------|-------|
| | [MHz] | [MHz] | [MHz] | [kHz] |
| Mid | 1732.6 | 4.638 | 4.1631 | - |

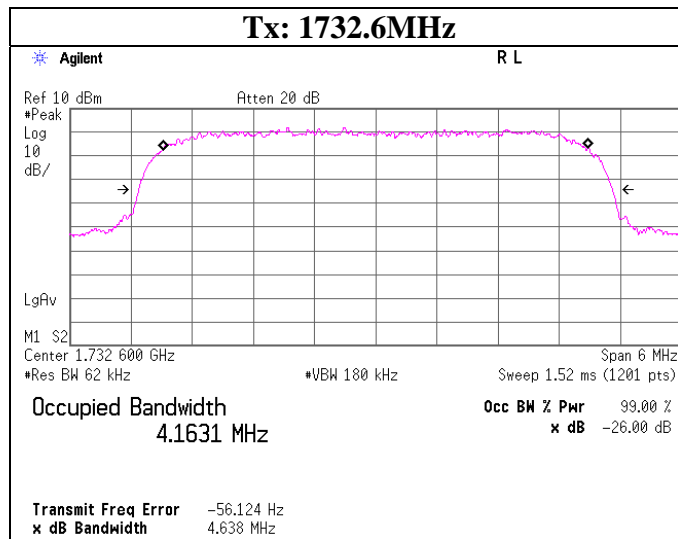

Band-Edge(Conducted)

Test place Head Office EMC Lab. No.6 Measurement Room
Report No. 33AE0113-HO
Date 08/23/2012
Temperature/ Humidity 23deg. C / 68% RH
Engineer Yutaka Yoshida
Mode Tx W-CDMA(RMC12.2kps), All Up Bits

| Frequency [MHz] | Reading [dBm] | Atten. [dB] | Cable Loss [dB] | Result [dBm] | Limit [dBm] | Margin [dB] |
|--------------------|------------------|----------------|-----------------------|-----------------|----------------|----------------|
| 1710.000 | -32.65 | 9.96 | 4.38 | -18.31 | -13.0 | 5.31 |
| 1755.000 | -34.78 | 9.96 | 4.39 | -20.43 | -13.0 | 7.43 |
| 1755.025 | -33.06 | 9.96 | 4.39 | -18.71 | -13.0 | 5.71 |

Sample Calculation : Result = Reading + Atten. + Cable Loss

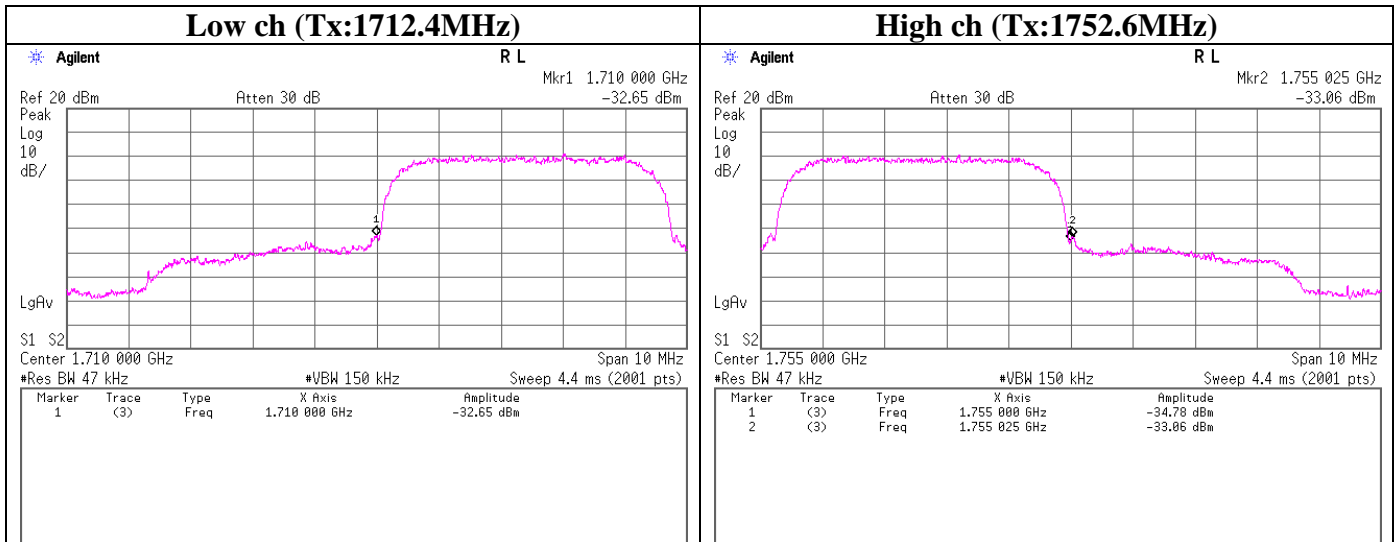

Band Edge (Radiated)

Report No. 33AE0113-HO
Test place Head Office EMC Lab. No.2 Semi Anechoic Chamber
Date 08/31/2012
Temperature / Humidity 24 deg. C / 55 % RH
Engineer Katsunori Okai
Mode Tx W-CDMA (RMC12.2kbps), All Up Bits

| Frequency [MHz] | Rx SA/TR Reading [dBuV] | | Tx SG Reading [dBm] | | Tx Cable Loss [dB] | Tx Ant. Gain [dBi] | Tx Ant. Atten. Loss [dB] | Result (EIRP) [dBm] | | Limit (EIRP) [dBm] | Margin [dB] | | Horizontal | | Vertical | | Remarks |
|--------------------|-------------------------------|------|---------------------------|-------|-----------------------------|-----------------------------|-----------------------------------|---------------------------|-------|--------------------------|----------------|------|---------------------------|-------------------------|---------------------------|-------------------------|---------|
| | HOR | VER | HOR | VER | | | | HOR | VER | | HOR | VER | Rx Ant. Height [cm] | Turn Table [deg.] | Rx Ant. Height [cm] | Turn Table [deg.] | |
| | 1710.00 | 52.2 | 53.0 | -22.0 | | | | -23.2 | 4.33 | | 9.52 | 0.00 | -16.8 | -18.0 | -13.0 | 3.8 | |
| 1755.00 | 51.7 | 50.3 | -22.2 | -26.2 | 4.38 | 9.63 | 0.00 | -17.0 | -21.0 | -13.0 | 4.0 | 8.0 | 100 | 304 | 107 | 308 | |

Calculation Result = SG Reading - Tx Cable Loss + Tx Antenna Gain - Tx Antenna Attenuator Loss

Rx-ANTENNA : Biconical Antenna(30M-300MHz), Logperiodic Antenna(300M-1000MHz), Horn Antenna(1G-20GHz)

Tx-ANTENNA : 120MHz tuned Dipole Antenna(30M-120MHz), Dipole Antenna(120M-1000MHz), Horn Antenna(1G-20GHz)

Other frequency noises omitted in this report were not seen or had enough margin (more than 20dB).

Detector : S/A PK (RBW: 47kHz, VBW: 150kHz)

Spurious Emission (Conducted)

Test place Head Office EMC Lab. No.6 Measurement Room
Report No. 33AE0113-HO
Date 08/23/2012
Temperature/ Humidity 23deg. C / 68% RH
Engineer Yutaka Yoshida
Mode Tx W-CDMA(RMC12.2kbps), All Up Bits

Limit Line

| Tx Frequency [MHz] | Limit [dBm] | Atten. [dB] | Cable Loss [dB] | Limit Line [dBm] |
|--------------------------|----------------|----------------|-----------------------|---------------------|
| 1712.4 | -13.0 | 9.96 | 4.38 | -27.3 |
| 1732.6 | -13.0 | 9.96 | 4.39 | -27.4 |
| 1752.6 | -13.0 | 9.96 | 4.39 | -27.4 |

Sample Calculation : Limit Line = Limit - Atten. - Cable Loss

Spurious Emission (Conducted)
Tx:1712.4MHz

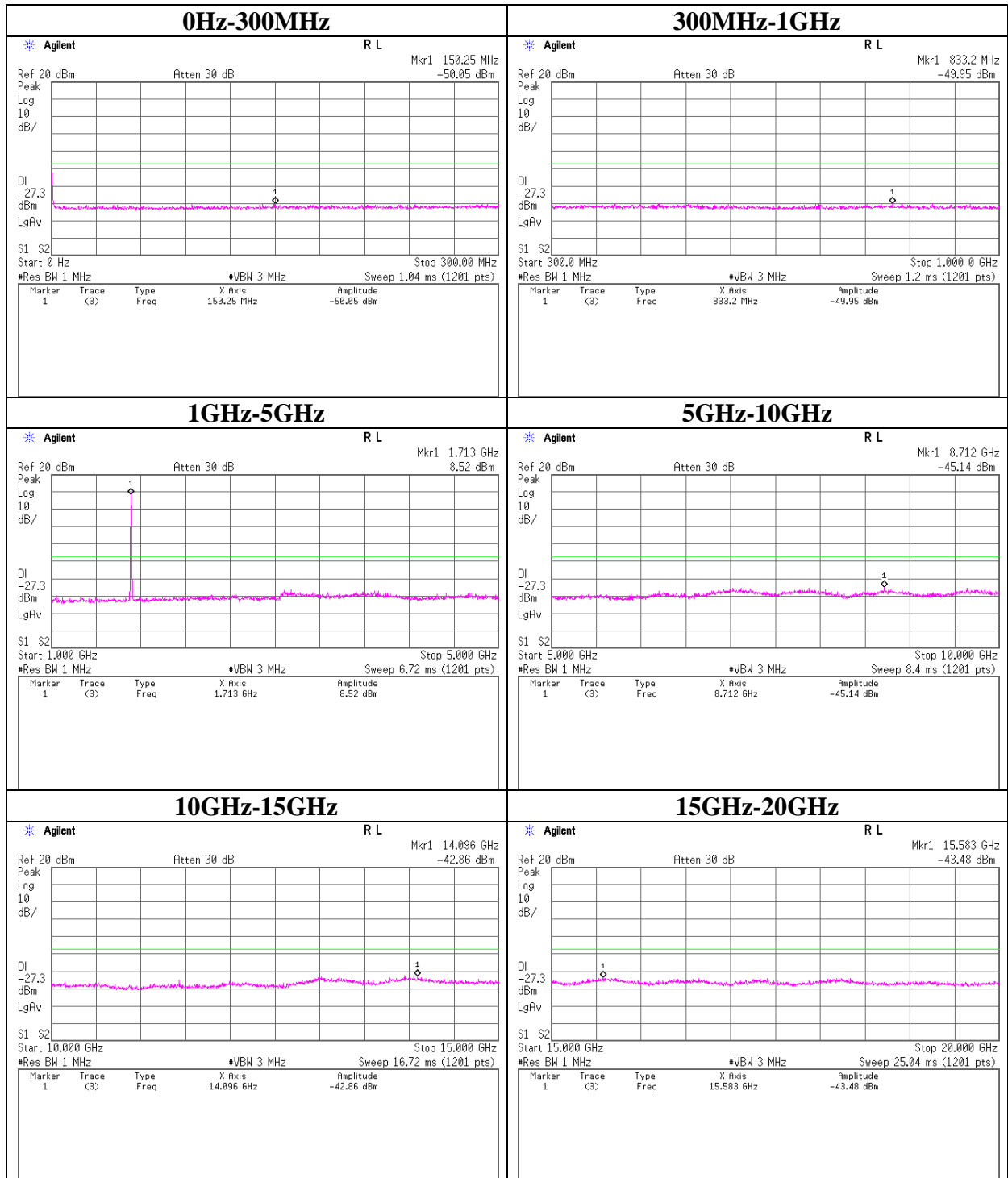

Spurious Emission (Conducted)
Tx:1732.6MHz

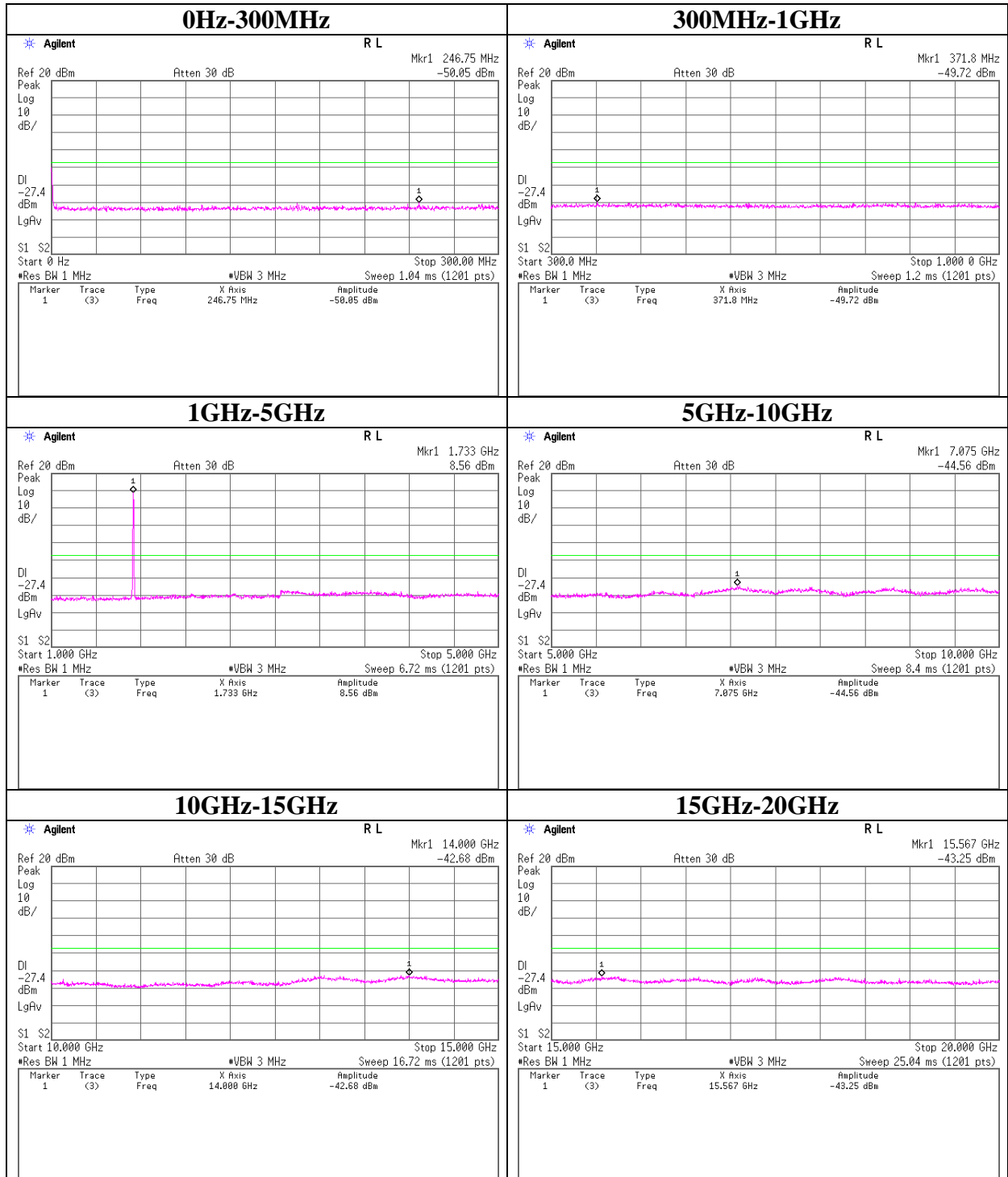

Spurious Emission (Conducted)
Tx:1752.6MHz

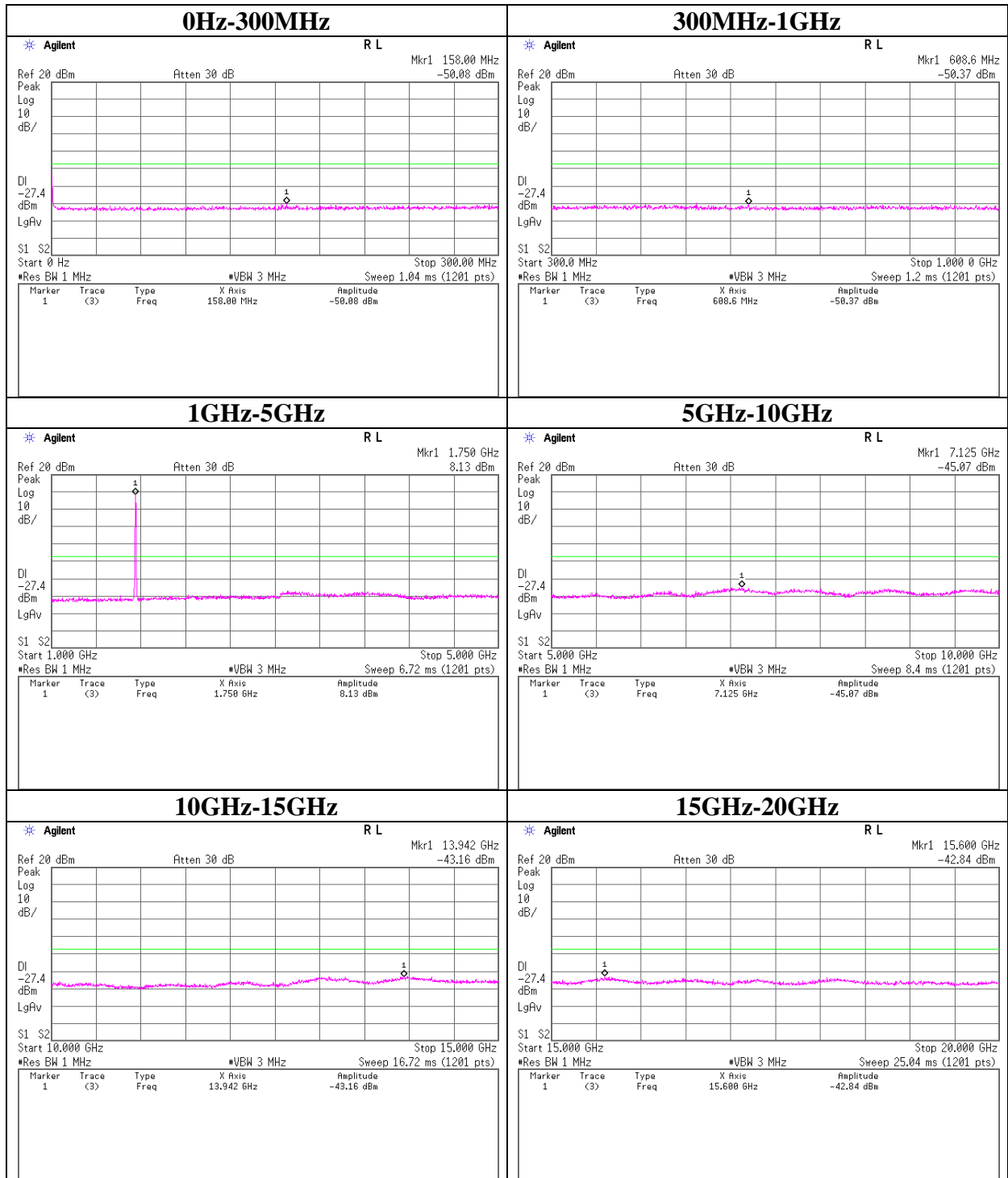

Spurious Emission (Radiated)

Report No. 33AE0113-HO
Test place Head Office EMC Lab. No.2 Semi Anechoic Chamber
Date 08/31/2012
Temperature / Humidity 24 deg. C / 55 % RH
Engineer Katsunori Okai
Mode Tx W-CDMA (RMC12.2kbps), All Up Bits

Tx: 1712.4MHz

| Frequency [MHz] | Rx SA/TR Reading [dBuV] | | Tx SG Reading [dBm] | | Tx Cable Loss [dB] | Tx Ant. Gain [dBi] | Tx Ant. Atten. Loss [dB] | Result (EIRP) [dBm] | | Limit (EIRP) [dBm] | Margin [dB] | | Horizontal | | Vertical | | Remarks | | |
|--------------------|-------------------------------|------|---------------------------|-------|-----------------------------|-----------------------------|-----------------------------------|---------------------------|-------|--------------------------|----------------|------|------------|-----|---------------------------|-------------------------|---------|---------------------------|-------------------------|
| | HOR | VER | HOR | VER | | | | HOR | VER | | HOR | VER | HOR | VER | Rx Ant. Height [cm] | Turn Table [deg.] | | Rx Ant. Height [cm] | Turn Table [deg.] |
| | | | | | | | | | | | | | | | | | | | |
| 3424.80 | 50.8 | 51.9 | -54.1 | -51.5 | 6.1 | 12.1 | 0.0 | -48.0 | -45.4 | -13.0 | 35.0 | 32.4 | 115 | 158 | 102 | 139 | | | |
| 5137.20 | NS | NS | - | - | - | - | - | - | - | -13.0 | - | - | - | - | - | - | | | |

Tx: 1732.6MHz

| Frequency [MHz] | Rx SA/TR Reading [dBuV] | | Tx SG Reading [dBm] | | Tx Cable Loss [dB] | Tx Ant. Gain [dBi] | Tx Ant. Atten. Loss [dB] | Result (EIRP) [dBm] | | Limit (EIRP) [dBm] | Margin [dB] | | Horizontal | | Vertical | | Remarks | | |
|--------------------|-------------------------------|------|---------------------------|-------|-----------------------------|-----------------------------|-----------------------------------|---------------------------|-------|--------------------------|----------------|------|------------|-----|---------------------------|-------------------------|---------|---------------------------|-------------------------|
| | HOR | VER | HOR | VER | | | | HOR | VER | | HOR | VER | HOR | VER | Rx Ant. Height [cm] | Turn Table [deg.] | | Rx Ant. Height [cm] | Turn Table [deg.] |
| | | | | | | | | | | | | | | | | | | | |
| 3465.20 | 50.9 | 51.7 | -54.7 | -53.1 | 6.1 | 12.2 | 0.0 | -48.6 | -47.0 | -13.0 | 35.6 | 34.0 | 100 | 235 | 100 | 138 | | | |
| 5197.80 | NS | NS | - | - | - | - | - | - | - | -13.0 | - | - | - | - | - | - | | | |

Tx: 1752.6MHz

| Frequency [MHz] | Rx SA/TR Reading [dBuV] | | Tx SG Reading [dBm] | | Tx Cable Loss [dB] | Tx Ant. Gain [dBi] | Tx Ant. Atten. Loss [dB] | Result (EIRP) [dBm] | | Limit (EIRP) [dBm] | Margin [dB] | | Horizontal | | Vertical | | Remarks | | |
|--------------------|-------------------------------|------|---------------------------|-------|-----------------------------|-----------------------------|-----------------------------------|---------------------------|-------|--------------------------|----------------|------|------------|-----|---------------------------|-------------------------|---------|---------------------------|-------------------------|
| | HOR | VER | HOR | VER | | | | HOR | VER | | HOR | VER | HOR | VER | Rx Ant. Height [cm] | Turn Table [deg.] | | Rx Ant. Height [cm] | Turn Table [deg.] |
| | | | | | | | | | | | | | | | | | | | |
| 3505.20 | 53.5 | 53.7 | -51.7 | -50.3 | 6.1 | 12.3 | 0.0 | -45.6 | -44.2 | -13.0 | 32.6 | 31.2 | 100 | 237 | 100 | 146 | | | |
| 5257.80 | NS | NS | - | - | - | - | - | - | - | -13.0 | - | - | - | - | - | - | | | |

Calculation Result = SG Reading - Tx Cable Loss + Tx Antenna Gain - Tx Antenna Attenuator Loss

Rx-ANTENNA : Biconical Antenna(30M-300MHz), Logperiodic Antenna(300M-1000MHz), Horn Antenna(1G-40GHz)

Tx-ANTENNA : 120MHz tuned Dipole Antenna(30M-120MHz), Dipole Antenna(120M-1000MHz), Horn Antenna(1G-40GHz)

Other frequency noises omitted in this report were not seen or had enough margin (more than 20dB).

NS : No signal detect.

Detector : S/A PK(RBW:1MHz/VBW:3MHz)

Frequency Stability(Temperature/Voltage Variation)

W-CDMA Band IV

Tx: 1732.6MHz

Test place Head Office EMC Lab. No.6 Measurement Room
Report No. 33AE0113-HO
Date 08/24/2012
Temperature/ Humidity 20 deg. C / 65% RH
Engineer Katsunori Okai
Mode Tx W-CDMA(RMC12.2kbps), All Up Bits

| Temp. [deg.C] | Volt. [V] | Frequency Reading [MHz] | Frequency Error [Hz] | Frequency Error [ppm] | Limit [ppm] |
|------------------|--------------|-------------------------------|----------------------------|-----------------------------|----------------|
| -30 | 3.70 | 1732.6000099 | 0.6 | 0.0003 | 2.5 |
| -20 | 3.70 | 1732.6000096 | 0.3 | 0.0002 | 2.5 |
| -10 | 3.70 | 1732.6000098 | 0.5 | 0.0003 | 2.5 |
| 0 | 3.70 | 1732.6000095 | 0.2 | 0.0001 | 2.5 |
| 10 | 3.70 | 1732.6000105 | 1.2 | 0.0007 | 2.5 |
| 20 | 3.70 | 1732.6000093 | 0.0 | 0.0000 | Reference |
| 30 | 3.70 | 1732.6000106 | 1.3 | 0.0008 | 2.5 |
| 40 | 3.70 | 1732.6000100 | 0.7 | 0.0004 | 2.5 |
| 50 | 3.70 | 1732.6000097 | 0.4 | 0.0002 | 2.5 |

| Temp. [deg.C] | Volt. [V] | Frequency Reading [MHz] | Frequency Error [Hz] | Frequency Error [ppm] | Limit [ppm] |
|------------------|--------------|-------------------------------|----------------------------|-----------------------------|----------------|
| 20 | 4.20 | 1732.6000095 | 0.2 | 0.0001 | 2.5 |
| 20 | 3.70 | 1732.6000093 | 0.0 | 0.0000 | Reference |
| 20 | 3.60 | 1732.6000114 | 2.1 | 0.0012 | 2.5 |

APPENDIX 3: Test instruments

EMI test equipment

| Control No. | Instrument | Manufacturer | Model No | Serial No | Test Item | Calibration Date * Interval(month) |
|-------------|---------------------------------|-------------------|--------------------------|---------------------------|-----------|---------------------------------------|
| MSA-04 | Spectrum Analyzer | Agilent | E4448A | US44300523 | AT | 2012/04/06 * 12 |
| MAT-24 | Attenuator(10dB)(above 1GHz) | Agilent | 8493C | 71389 | AT | 2012/06/27 * 12 |
| MCC-66 | Microwave Cable 1G-40GHz | Suhner | SUCOFLEX102 | 28636/2 | AT | 2012/04/25 * 12 |
| MCC-96 | Microwave Cable 1G-40GHz | Schner | SUCOFLEX102 | 30817/2 | AT | 2012/05/09 * 12 |
| MPSC-01 | Power splitters/Combiners | Mini-Circuit | ZFSC-2-2500 | 0124 | AT | 2011/09/27 * 12 |
| MURC-03 | Radio Communication Analyzer | Anritsu | MT8815B | 6200711471 | AT/RE | 2011/11/26 * 12 |
| MOS-14 | Thermo-Hygrometer | Custom | CTH-201 | - | AT | 2012/02/06 * 12 |
| MURC-02 | Wireless Communication Test Set | Agilent | E5515C | GB47050683 | AT | 2011/11/26 * 12 |
| MAEC-03 | Semi Anechoic Chamber(NSA) | TDK | Semi Anechoic Chamber 3m | DA-10005 | RE | 2012/02/24 * 12 |
| MOS-15 | Thermo-Hygrometer | Custom | CTH-180 | - | RE | 2012/02/06 * 12 |
| MJM-06 | Measure | PROMART | SEN1955 | - | RE | |
| COTS-MEMI | EMI measurement program | TSJ | TEPTO-DV | - | RE | - |
| MBA-03 | Biconical Antenna | Schwarzbeck | BBA9106 | 1915 | RE | 2011/10/15 * 12 |
| MLA-03 | Logperiodic Antenna | Schwarzbeck | USLP9143 | 174 | RE | 2011/10/15 * 12 |
| MCC-51 | Coaxial cable | UL Japan | - | - | RE | 2012/07/12 * 12 |
| MAT-09 | Attenuator(6dB) | Weinschel Corp | 2 | BK7973 | RE | 2011/11/02 * 12 |
| MPA-13 | Pre Amplifier | SONOMA INSTRUMENT | 310 | 260834 | RE | 2012/03/16 * 12 |
| MAEC-02 | Semi Anechoic Chamber(NSA) | TDK | Semi Anechoic Chamber 3m | DA-06902 | RE | 2012/06/29 * 12 |
| MOS-22 | Thermo-Hygrometer | Custom | CTH-201 | 0003 | RE | 2012/02/06 * 12 |
| MJM-14 | Measure | KOMELON | KMC-36 | - | RE | - |
| MHA-06 | Horn Antenna 1-18GHz | Schwarzbeck | BBHA9120D | 254 | RE | 2012/02/22 * 12 |
| MPA-10 | Pre Amplifier | Agilent | 8449B | 3008A02142 | RE | 2012/01/25 * 12 |
| MHA-05 | Horn Antenna 1-18GHz | Schwarzbeck | BBHA9120D | 253 | RE | 2012/06/27 * 12 |
| MCC-132 | Microwave Cable | HUBER+SUHNER | SUCOFLEX104 | 336161/4(1m) / 340639(5m) | RE | 2011/09/06 * 12 |
| MHF-06 | High Pass Filter 3.5-24GHz | TOKIMEC | TF323DCA | 601 | RE | 2012/05/30 * 12 |
| MCC-48 | Microwave Cable 1G-26.5GHz | Suhner | SUCOFLEX102 | 23771/2 | RE | 2012/08/27 * 12 |
| KSG-05 | Signal Generator | Rohde & Schwarz | SMR40 | 100137 | RE | 2012/07/23 * 12 |
| MSA-03 | Spectrum Analyzer | Agilent | E4448A | MY44020357 | RE | 2011/11/23 * 12 |

The expiration date of the calibration is the end of the expired month.

All equipment is calibrated with valid calibrations. Each measurement data is traceable to the national or international standards.

As for some calibrations performed after the tested dates, those test equipment have been controlled by means of an unbroken chains of calibrations.

Test Item:

RE: Radiated Emission

AT: Antenna terminal conducted test

UL Japan, Inc.

Head Office EMC Lab.

4383-326 Asama-cho, Ise-shi, Mie-ken 516-0021 JAPAN

Telephone : +81 596 24 8116

Facsimile : +81 596 24 8124