

1	2	3	4	5	6	7	8
---	---	---	---	---	---	---	---

A	Rev. No	

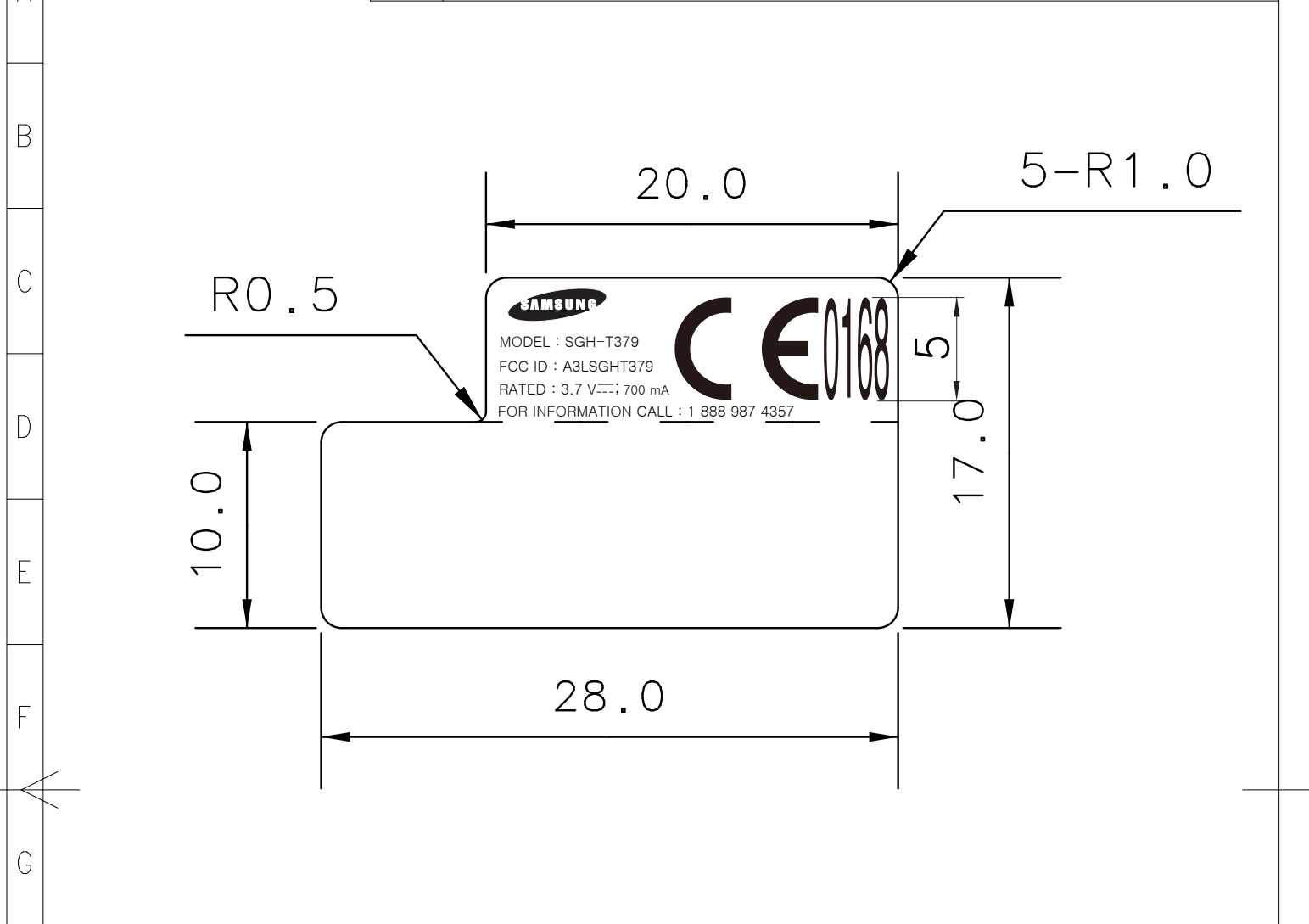

Technical Description

1. Use FILM provided by SAMSUNG for letter and contents
2. Background color is **WHITE**, letter color is **BLACK** (reverse for SAMSUNG LOGO)
3. Put Back paper on the back side after the adhesive.
4. No blur and spread for letter
5. Proceed with manufacturing process after the approval of R&D Group
6. The spec. of product must be based on approved limit samples.
7. Stock on as a ROLL
8. Follow drawing instruction above for CE or WEEE mark
9. Unify material and color as one color (blue) for glassine paper

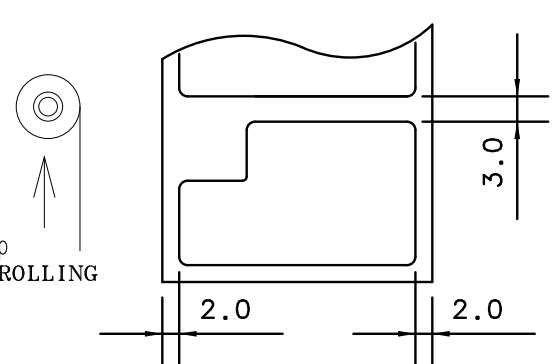

J	MAT.	White Polypropylene 80 μ			FIN.	translucent OPP Laminating+UVP Coating	
	TITLE	SGH-T379					
K	UNIT	mm	DESIGNED	CHECKED	APPROVED	PROJECTION	
	TOLERANCE	+0.0 -0.1	Jaejin Lee	Keonghwan Cho	Junesop Kim		
L	SCALE	N/S				SHEET NO	1/1
	Manufacture	HANSUNG	110322	110322	110322		
			Doc. CODE				



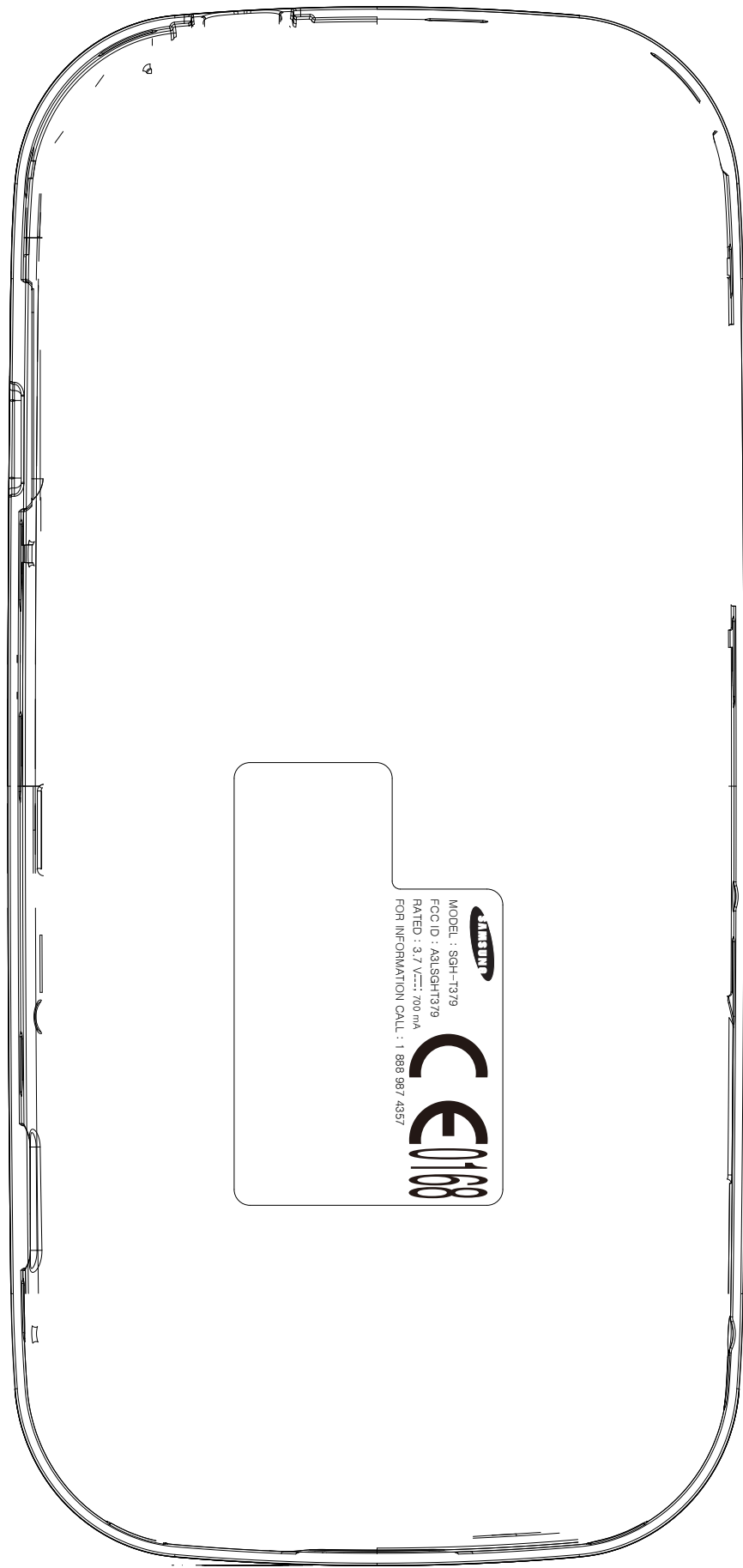

The label is placed inside the battery compartment