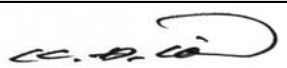
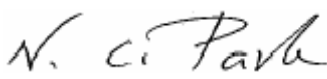
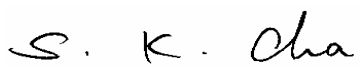

# EMC Test Report

## According to FCC Part 15 Subpart B

<b>Project No.</b>	LBE051800
<b>Equipment under Test</b>	
Applicant	Samsung Electronics Co., Ltd. 416 Maetan3-Dong, Yeongtong-Gu, Suwon-Si, Gyeonggi-Do, Korea, 443-742
FCC ID	<b>A3LSECZPOB</b>
Product Name	USB Flash Drive
Model Name	MC8QD04GZMPP-S5A00
Manufacturer	Samsung Electronics Co., Ltd.
<b>Date of Test</b>	July 23, 2005
<b>Issued Date</b>	August 1, 2005

	<b>Name/Position</b>	<b>Signature</b>
<b>Tested by</b>	Kyeong Dong, Kim Test Engineer	
<b>Reviewed by</b>	No Cheon, Park Manager of EMC Lab.	
<b>Authorized by</b>	Seung Kyu, Cha Chief of EMC Lab.	

1. This test reports does not constitute an endorsement by NIST/NVLAP or U.S Government.
2. This test report is to certify that the tested device properly complies with the requirements of FCC Rules and Regulations Part 15 Subpart B Unintentional Radiators.

All tests necessary to show compliance to the requirements were and these results met the specifications requirement.

**This laboratory is registered by the NIST/NVLAP, U.S.A.**

**The test reported herein have been performed in accordance with its terms of registration.**



NVLAP LAB CODE 200623-0

3. FCC filing Registration Number : 873282

## **Table of Contents**

### **1. General Information**

- 1.1 Basic Information related Product
- 1.2 Detail Information related Product
- 1.3 Operating mode and condition
- 1.4 Test System Details
- 1.5 Equipment Modifications
- 1.6 Test Procedure
- 1.7 Test Configuration
- 1.8 Applied Standard
- 1.9 Test Facility

### **2. Summary of Test Results**

### **3. Description of individual tests**

- 3.1 Conducted Emission
- 3.2 Radiated Emission

### **4. Appendix**

- 4.1 Test Photography
- 4.2 EUT Photography

# 1. General Information

## 1.1 Basic Information related Product

Applicant	Samsung Electronics Co., Ltd.
Model name	MC8QD04GZMPP-S5A00
Applicant Address	416Maetan3-Dong, Yeongtong-Gu, Suwon-Si, Gyeonggi-Do, Korea, 443-742
Contact Person	Kyeong Dong, Kim
Kind of product	USB Flash Drive
Variant list	-
Manufacturer	Samsung Electronics Co., Ltd.
New / Alternative / Permissive change Information	New

## 1.2 Detail Information related Product

Specification

Item	Specification	Remark
USB Flash Drive	<ul style="list-style-type: none"> <li>- Fully compatible with the USB 2.0 High speed , Specification, USB-IF certified</li> <li>- USB Specification V1.1 Mass Storage Compliance</li> <li>- USB Bulk Only Mass Storage Support</li> <li>- USB Class Definition for Bootability Support</li> <li>- Interface Speed: up to               <ul style="list-style-type: none"> <li>- High Speed: 480M bps</li> <li>- Full Speed: 12M bps</li> </ul> </li> <li>- High Performance : Sequential Read/Write: 25MB/sec</li> <li>- Storage Capacities: 4GB</li> <li>- Low Vcc Program Inhibit Function</li> <li>- Auto Sleep Mode</li> <li>- USB Bus Powered (4.75 Volt -5.25 Volt)</li> <li>- Suspend: &lt;= 500uA</li> </ul>	-

Operating Frequency

Crystal : 12MHz (Ceramic SMD-type)

### **1.3 Operating Mode and Condition**

The EUT system tested was configured in a fashion that a customer would typically use. Cable were attached to each of the available I/O Ports. Where applicable, peripherals were attached to the I/O cables. The mode of operation utilized for testing was selected to best simulate typical EUT use.

Finally we found worst case emission. So we used windows media player program, It operated read continuously on EUT. (worst case)

Further details of cabling and configuration are shown in the test system configuration.

### **1.4 Test System Details**

Refer to 1.2

### **1.5 Equipment Modifications**

No equipment modifications were required.

## 1.6 Test Procedure

### 1.6.1 Conducted Emission

The EUT was placed on a platform nominal size, 1m by 1.5m, raised 80cm above the conducting ground plane. The rear of tabletop was located 40cm to the vertical conducting ground plane.

The rear of EUT, including peripherals was aligned and flush with rear of tabletop.

All other surfaces of tabletop was at least 80cm from any other grounded conducting surface.

I/O cables and AC cables that were connected to the peripherals were bundled in center.

They were folded back and forth forming a bindle 30cm to 40cm long and were handed at a 40cm height to the ground plane.

Each EUT current-carrying power lead, except the ground(safety)lead, were individually connected through a LISN to the input power source.

All unused 50 ohm connectors of the LISN were resistively terminated in 50 ohm when not connected to the measuring equipment.

Frequency Band [MHz]	Instrument	Detector	Resolution Bandwidth	Video Bandwidth
0.15 to 30	EMI Receiver	Quasi-Peak	9kHz	-
		Average	9kHz	-

### 1.6.2 Radiated Emission

EUT was placed on a platform of nominal size, 1m by 1.5m, raised 80cm above the conducting ground plane.

The rear of EUT, including peripherals was aligned and flush with rear of tabletop.

I/O cables that were connected to the peripherals were bundle in center.

They were folded back and forth forming a bundle 30cm to 40cm long and were hanged 40cm height to the ground plane.

Test was made with the antenna positioned in both the horizontal and vertical planes of polarization. The measurement antenna was varied in height above the conducting ground plane and the run table azimuth was varied to obtain the maximum signal strength

The system configuration, clock speed, mode of operation or video resolution, turntable azimuth with respect to the antenna were noted for each frequency found.

The spectrum was scanned from 30 to 1000 MHz using biconi-Log antenna.

Also, the EMI RECEIVER was scanned from 1000 to 1800MHz using linearly polarization Double ridge horn antennas were used. The explanation of measuring instrument setup when Respective function is used in any frequency band is as following;

Frequency Band [MHz]	Instrument	Detector	Resolution Bandwidth	Video Bandwidth
30 to 1000	EMI Receiver	Quasi-Peak	120kHz	-
Above 1000	EMI Receiver	Peak	1MHz	1MHz

## 1.7 Test Configuration

### Used EUT and Peripherals

No	Device	Model Name	Serial #	Maker	Note
A	USB Flash Drive	MC8QD04GZMPP-S5A00	-	Samsung	EUT
B	Note PC	PP05S	CN-0G6951-36521- 4BB-005E	Samsung	DoC
C	AC Adaptor	ADP-50HH	CN-0W6052-48661- 4AK-00AM	DELL	-
D	CAMCODER	DCR-PC115	1985987	Sony	DoC
E	USB FDD	SFD-321U	P4LMB047516	Dongguan Samsung	DoC

### Used Cable Description

No	Connect Cable	Length [m]	Shielded [Y/N]	Remark
1	Power	1.5	No	For PC
2	1394	1.6	Yes	-
3	USB	0.6	Yes	-

Block Diagram

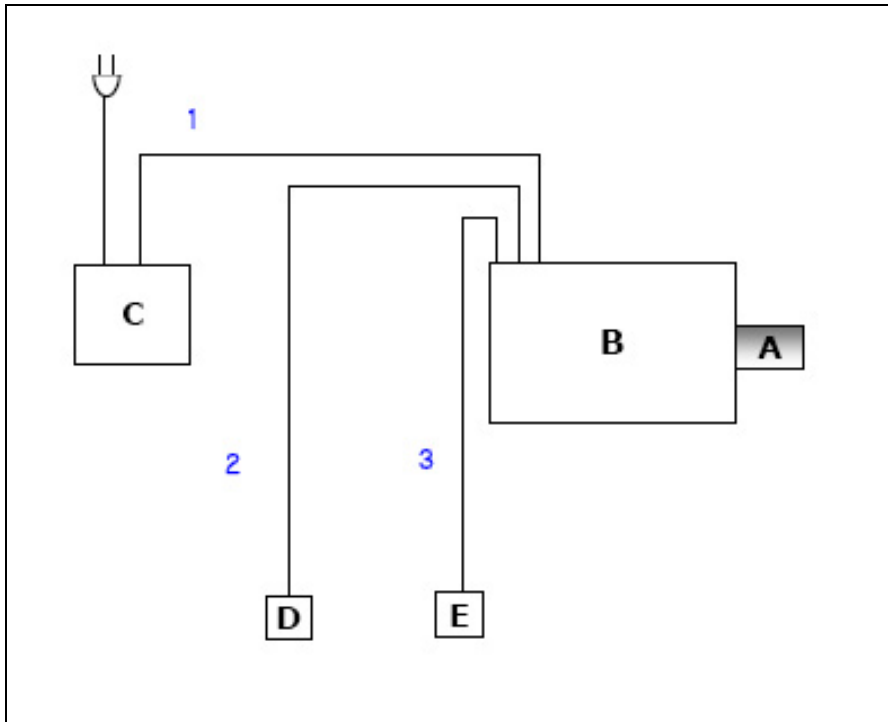

## 1.8 Applied Standards

List

Product or Generic Standards	Basic Standards
FCC Part15 B	ANSI C63.4 : 2003

## 1.9 Test Facility

General Information

The sites are constructed in conformance with the requirements of ANSI C63.4 and CISPR 22, 16-1, 16-2.

This EMC Testing Lab. is accredited by Korea Laboratory Accreditation Scheme(KOLAS) which signed the International Laboratory Accreditation Cooperation (ILAC) Mutual Recognition Arrangement(MRA) for the above test item(s) and test method(s).

This Lab. is operated as testing laboratory in accordance with the requirements of ISO/IEC 17025:1998.

Accreditation and Listing



Uncertainty

(According to NAMAS Pub.NIS81)

**Samsung IT EMC Test Lab.**

**Conducted Emission** : ±1.9dB

**Radiated Emission** Bi-Log Antenna : ±5.1dB

## 2. Summary of Test Results

**Result : PASS**

The equipment under test(EUT) has been found to comply with the applied standards.

Section of the Product Standard		Applied Standard	Result
Electromagnetic Emission Test			
3.1	Conducted Emission	ANSI C63.4 : 2003	Complied
3.2	Radiated Emission	ANSI C63.4 : 2003	Complied

### 3.1 Conducted Emission

Test Information	
Test Engineer	Kyeong Dong, Kim
Test Date	July 23, 2005
Climate Condition	Ambient Temperature : 23 °C Relative Humidity : 59%
	Atmospheric Pressure 1003mbar
Test Place	Shield Room #2

#### Test Equipments

Equipment	Model Name	Manufacturer	Serial No.	Calibration	
				Next Date	Interval
EMI TEST RECEIVER	ESCS30	R&S	830986/004	2006-02-17	12
LISN	3810/2NM	EMCO	2251	2006-02-01	12
LISN	ESH3-Z5	R&S	831887/004	2005-08-31	12

<b>Measurement Results</b>	<p><b>Passed</b></p> <p>The Measured emissions of the EUT have found to be below the specified limits.</p>
----------------------------	--

## Test Data & Graph

The Initial step in collecting conducted data was to perform a peak and average scan over the measurement range using a receiver

The find data represents worst-case emissions.

\* QP : Quasi-peak, AV: Average

\* Result = Meter Reading(QP or AV) + Total Loss(LISN Insertion loss + Cable loss)

\* Margin = Limit – Result

### 1. TEST DATA & GRAPH

#### 1.1 Quasi Peak

##### **MEASUREMENT RESULT: "MEMORY\_4GB\_fin QP"**

Frequency MHz	Level dB $\mu$ V	Transd dB	Limit dB $\mu$ V	Margin dB	Line	PE
0.209000	49.80	0.1	63	13.2	N	GND
0.279000	41.80	0.1	61	19.2	N	GND
12.892000	35.10	0.7	60	24.9	L1	GND
13.231000	29.90	0.7	60	30.1	L1	GND
13.301000	29.90	0.7	60	30.1	L1	GND
13.371000	29.90	0.7	60	30.1	L1	GND
13.439000	26.80	0.7	60	33.2	N	GND
13.511000	29.80	0.8	60	30.2	L1	GND
13.583000	29.50	0.8	60	30.5	L1	GND
13.649000	26.00	0.8	60	34.0	N	GND

**1.2 Average**

**MEASUREMENT RESULT: "MEMORY\_4GB\_fin AV"**

Frequency	Level	Transd	Limit	Margin	Line	PE
MHz	dB $\mu$ V	dB	dB $\mu$ V	dB		
0.209000	41.60	0.1	53	11.4	N	GND
13.313000	24.50	0.7	50	25.5	L1	GND
13.439000	14.90	0.7	50	35.1	N	GND
13.509000	22.80	0.8	50	27.2	N	GND
13.577000	17.80	0.8	50	32.2	N	GND
13.594000	23.90	0.8	50	26.1	L1	GND
13.643000	17.40	0.8	50	32.6	N	GND
13.664000	22.90	0.8	50	27.1	L1	GND
13.709000	21.40	0.8	50	28.6	N	GND
13.775000	19.50	0.8	50	30.5	N	GND

**- Graph -**

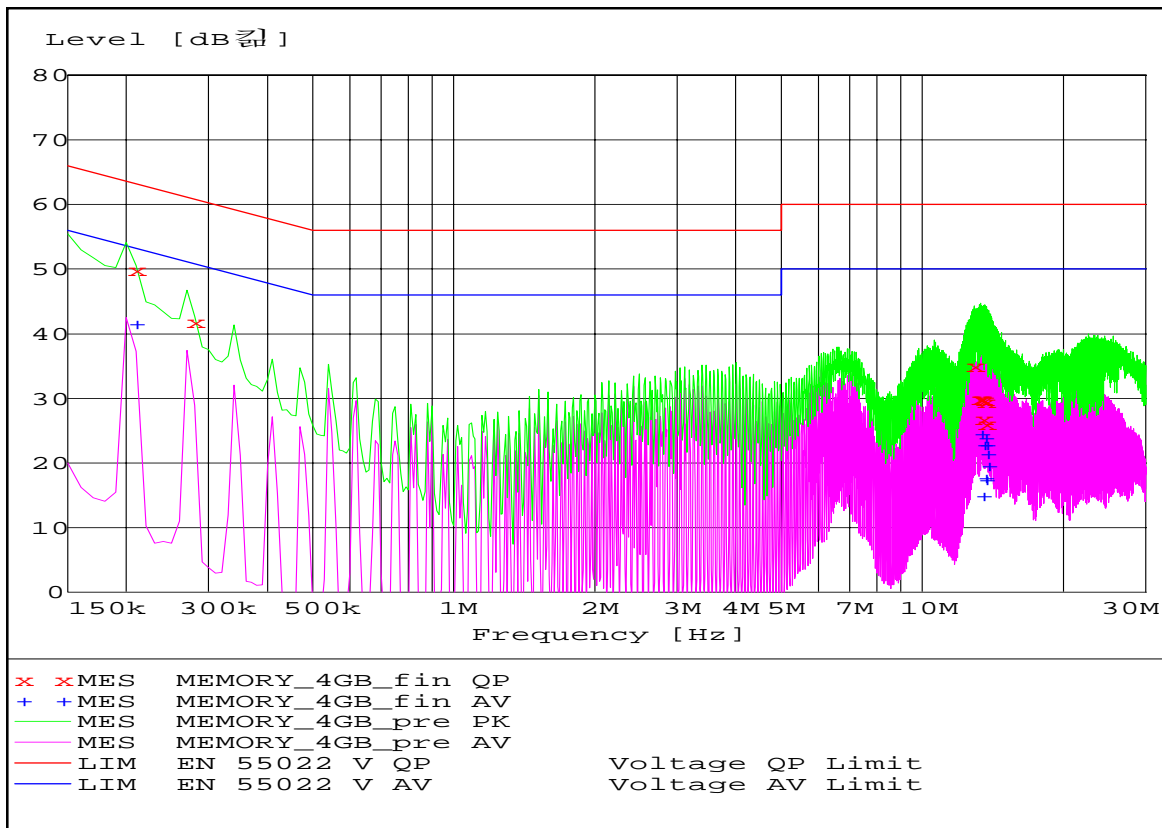

### 3.2 Radiated Emission

Test Information	
Test Engineer	Kyeong Dong, Kim
Test Date	July 23, 2005
Climate Condition	Ambient Temperature : 20℃ Relative Humidity : 60%
Test Place	Atmospheric Pressure 1002mbar 10m Semi Anechoic Chamber

#### Test Equipments

Equipment	Model Name	Manufacturer	Serial No.	Calibration	
				Next Date	Interval
Test Receiver	ESIB-26	R&S	100147	2005-10-04	12
Turn Table	DT430	HD	430/691/01	N/A	N/A
Antenna Mast	MA240	HD	240/678 BJ:01	N/A	N/A
Controller	HD100	HD	100/723	N/A	N/A
Preamplifier	CPA9232	Schaffner	1053	2005-08-14	12
BILOG Antenna	CBL6112B	Schaffner	2804	2005-11-09	12

<b>Measurement Results</b>	<b>Passed</b> No Operation errors were detected during or after the applied test.
----------------------------	--

**Test Data & Graph**

The initial step in collecting radiated data was to perform a peak scan over the measurement range using a receiver. All modes of operation were investigated and the worst-case emission are reported. The minimum margin to the limit is as follows:

All other emission are non-significant.

- \* Receiving Antenna Mode : Horizontal, Vertical
- \* Test distance : 10m (Semi-Anechoic Chamber)
- \* Result = Meter Reading + Total Loss(Antenna factor + Cable loss-Amp. Gain)
- \* Margin = Limit – Result

Samsung Electronics Co., Ltd  
IT Center

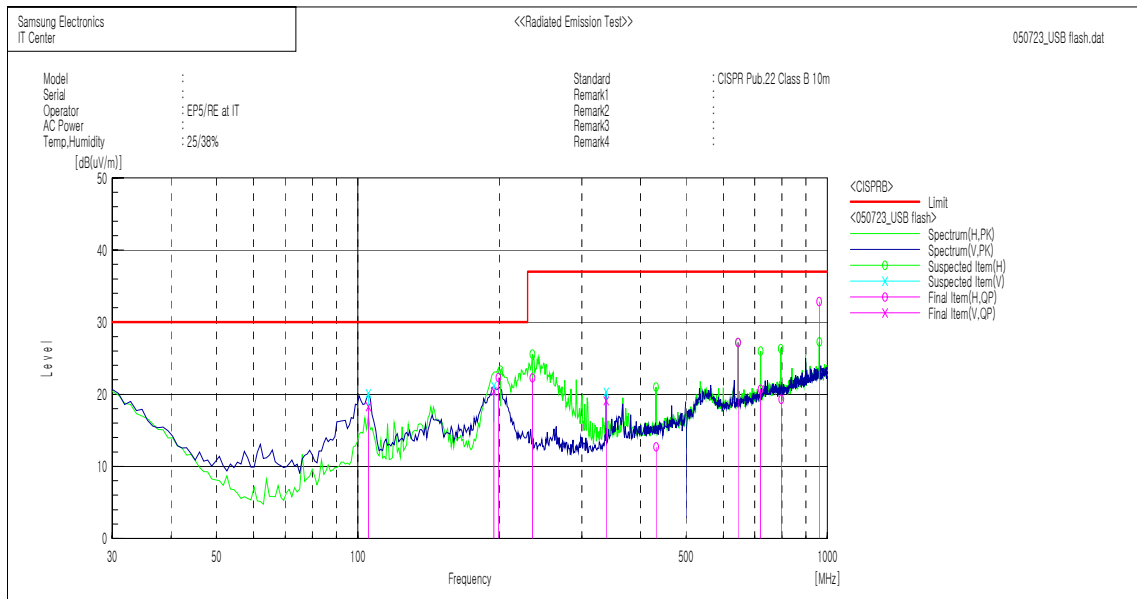

Final Result

No.	Frequency [MHz]	(P)	Reading QP [dB(uV)]	c.f [dB(1/m)]	Result QP [dB(uV/m)]	Limit [dB(uV/m)]	Margin QP [dB]	Height [cm]	Angle [deg]	Remark
1	105.351	V	27.0	-8.7	18.3	30.0	11.7	176.0	341.0	
2	194.830	V	30.6	-10.2	20.4	30.0	9.6	239.0	338.0	
3	199.271	H	32.5	-10.2	22.3	30.0	7.7	376.0	128.0	
4	235.392	H	30.5	-8.2	22.3	37.0	14.7	400.0	149.0	
5	337.996	V	23.3	-4.2	19.1	37.0	17.9	400.0	256.0	
6	431.831	H	13.9	-1.2	12.7	37.0	24.3	232.0	65.0	
7	645.291	H	24.5	2.7	27.2	37.0	9.8	143.0	230.0	
8	720.441	H	16.7	4.0	20.7	37.0	16.3	387.0	191.0	
9	797.390	H	14.5	4.8	19.3	37.0	17.7	113.0	63.0	
10	960.105	H	25.4	7.4	32.8	37.0	4.2	271.0	156.0	

## 4. Appendix

### 4.1 Test Photography



Picture 1. Conducted Emission (Front)



Picture 2. Conducted Emission (Rear)

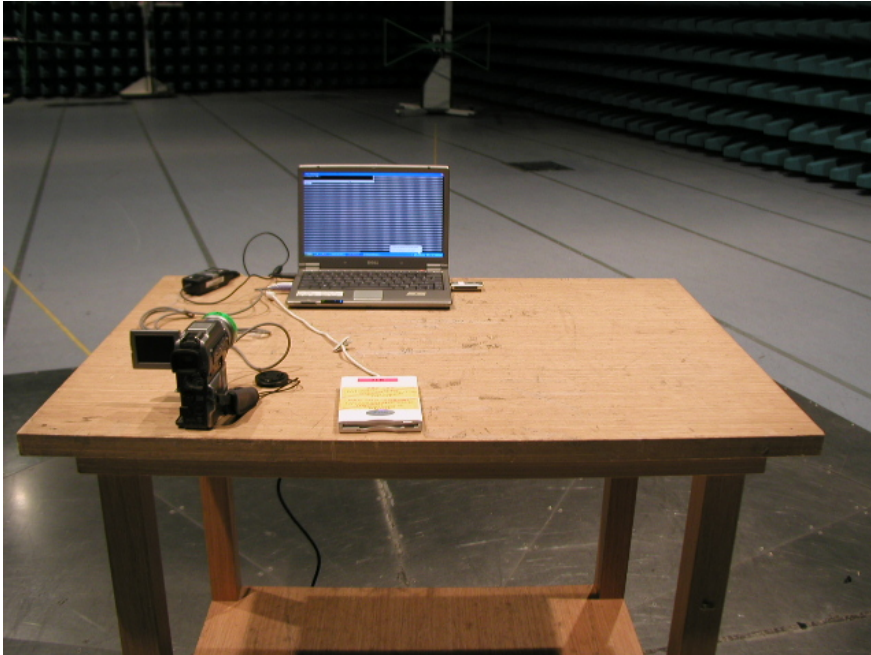

Picture 3. Radiated Emission (Front)

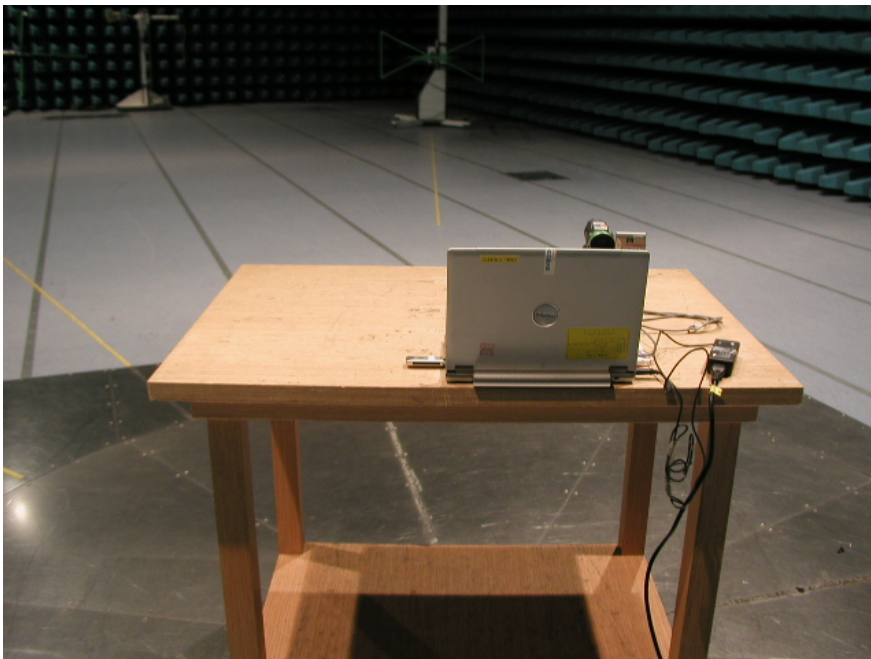

Picture 4. Radiated Emission (Rear)

## 4.2 EUT Photography



Picture 5. EUT (Top)



Picture 6. EUT (Bottom)



Picture 7. EUT (Inside)

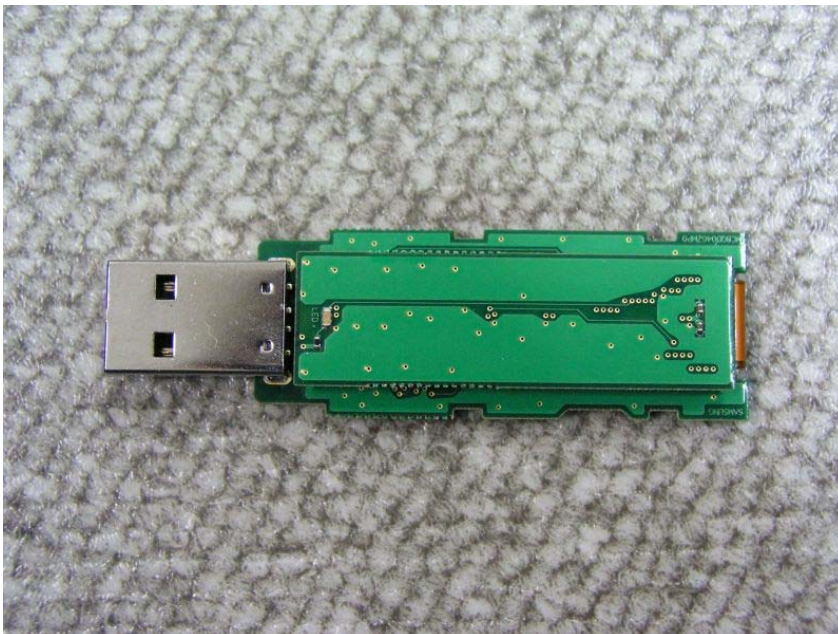

Picture 8. EUT (Inside)

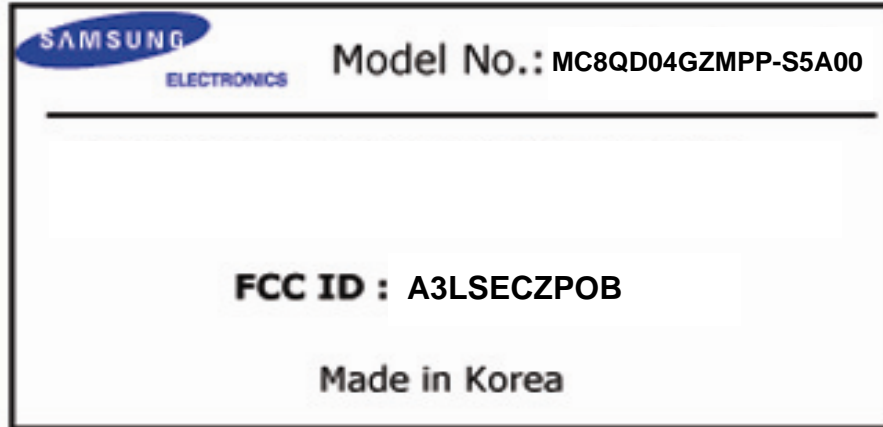

Picture 9. Label