

EMC TEST REPORT

Project No.	LBE20113599	Issue No.	2
Applicant	Name of organization	Samsung Electronics Co., Ltd.	
	Address	416 Maetan 3-Dong, Yeongtong-Gu, Suwon-Si, Gyeonggi-Do 443-742 Korea	
	Date of application	August 29, 2011	
EUT	Type of device	Class B personal computers and peripherals	
	Equipment authorization	<input type="checkbox"/> Declaration of Conformity <input checked="" type="checkbox"/> Certification <input type="checkbox"/> Verification	
	FCC ID	A3LSCX3405W	
	Kind of product	MONO LASER MFP	
	Model No.	SCX-3405W	
	Variant Model No.	SCX-3400, SCX-3405	
	Manufacturer	1) Samsung Electronics Co., Ltd. 259, Gongdan-Dong, Gumi-City, Gyeongsangbuk-Do, Korea 730-030 2) Samsung Electronics (Shandong) Digital Printing Co., Ltd. 264209, Samsung Road, Weihai Hi-Tech. IDZ, Shandong Province, P.R.China 3) Weihai Shin Heung Digital Electronics Co., Ltd. 98, Samsung Road, Weihai Hi-Tech. IDZ, Shandong Province, P.R.China 4) Intops : Intops (Weihai) Electronics Co., Ltd. Keji Road-268-1, Weihai Hi-Tech, Industries Development Zone , Shandong Province , CHINA	
Applied Standards	FCC Part 15, Subpart B / ANSI C63.4-2009		
Test Period	August 31, 2011 ~ September 05, 2011		
Issue date	September 20, 2011		
Test result : Complied			
<p>The equipment under test has found to be compliant with the applied standards. The result is not applied the uncertainty concept. This mean that the result is applied the original (standard) limit. (Refer to the attached test result for more detail.)</p>			
Tested by : Joung Jae Park		Reviewed by : Tae Young, Jang	
<i>J.J. park</i>		<i>Tae Young, Jang</i>	
<p>The test results in this report only apply to the tested sample. This report must not be reproduced, except in full, without written permission from CS & Environment center.</p>			
			
416 Maetan 3-Dong, Yeongtong-Gu, Suwon-Si, Gyeonggi-Do, 443-742 Korea Tel: 82 31 277 7752, Fax: 82 31 277 7753			

Table of contents

1. Report information	
1.1 Revision history	- 3 page
1.2 Sample calculation	- 3 page
2. Summary of test results	
2.1 Emission	- 3 page
3. General Information	
3.1 Test facility	- 4 page
4. Test configuration	
4.1 Test configuration	- 4 page
4.2 EUT operating mode(s)	- 6 page
4.3 Details of Sampling	- 6 page
4.4 Clock Frequencies	- 6 page
4.5 EUT Description	- 7 page
4.6 Test configuration and condition	- 8 page
4.7 Measurement uncertainty	- 8 page
5. Result of individual tests	
5.1 Conducted disturbance	- 9 page
5.2 Radiated disturbance	- 21 page
Appendix – EUT photography	- 39 page

1. Report information

1.1 Revision history

No.	Revised detailed information
Issue 1	CPU Speed (533 MHz → 433 MHz)
Issue 2	Section 4.1 is given an incorrect page number in the Table of Contents on page 2 of the test report (5 page → 4 page)

1.2 Sample calculation

1.2.1 Conducted disturbance (at 10 MHz)

- Class B limit = 60 dB μ V (Quasi-peak limit)
- Level (50 dB μ V) = Meter Reading (40.2 dB μ V) + factor (9.8 dB, AMN factor 9.7 dB + Cable loss 0.1 dB)
- Margin (10 dB) = Limit (60 dB μ V) – Level (50 dB μ V) = 10 dB below limit

1.2.2 Radiated disturbance (at 100 MHz)

- Class B limit = 40 dB μ V/m at 3 m
- Level (30 dB μ V/m) = Meter Reading (50 dB μ V) + factor (- 20 dB(1/m), antenna factor + cable loss – amplifier gain)
- Margin (10 dB) = Limit (40 dB μ V/m) – Level (30 dB μ V/m) = 10 dB below limit

2. Summary of test results

2.1 Emission

The EUT has been tested according to the following specifications:

Applied	Test type	Applied standard	Result
<input checked="" type="checkbox"/>	Conducted Disturbance (Mains Port)	FCC Part 15 Subpart B / ANSI C63.4-2009	Complied
<input checked="" type="checkbox"/>	Radiated Disturbance		Complied

3. General Information

3.1 Test facility

The CS & Environment center is located on Samsung Electronics Co., Ltd. at 416 Maetan 3-Dong, Yeongtong-Gu, Suwon-Si, Gyeonggi-Do, South Korea.

All testing are performed in Semi-anechoic chambers conforming to the site attenuation Characteristics defined by ANSI C63.4, CISPR 22, 16-1 and 16-2. and Shielded rooms.

The CS & Environment center is operated as testing laboratory in accordance with the requirements of ISO/IEC 17025:2005.

4. Test Setup configuration

4.1 Test configuration

4.1.1 Test Peripherals

The cables used for these peripherals are either permanently attached by the peripheral manufacturer or coupled with an assigned cable as defined below.

The following is a listing of the EUT and peripherals utilized during the performance of EMC test:

Seq	Description	Model No.	Serial No.	Manufacturer	Fcc ID / DoC
A	Mono laser MFP	SCX-3405W	-	SAMSUNG	A3LSCX3405W
B	Notebook PC	PP18L	29359007709	Dell	DoC
C	Adapter	LA65NS1-00	CN-OYD637-71615-83C-DE60	Dell	DoC
D	USB mouse	MS201U	73H1886	Monterey international	DoC
E	Head set	COV903	-	COSY	-

4.1.2 Test cables

No.	Connected cable	Length [m]	Shielded [Y/N]	Note
1	Power	1.8	No	For EUT
2	Power	1.8	No	For Notebook PC
3	USB	1.5	Yes	From Notebook PC to EUT
4	USB	1.8	Yes	From Notebook PC to Mouse
5	Audio	1.5	No	From Notebook PC to Headphone

4.1.3 Test arrangement

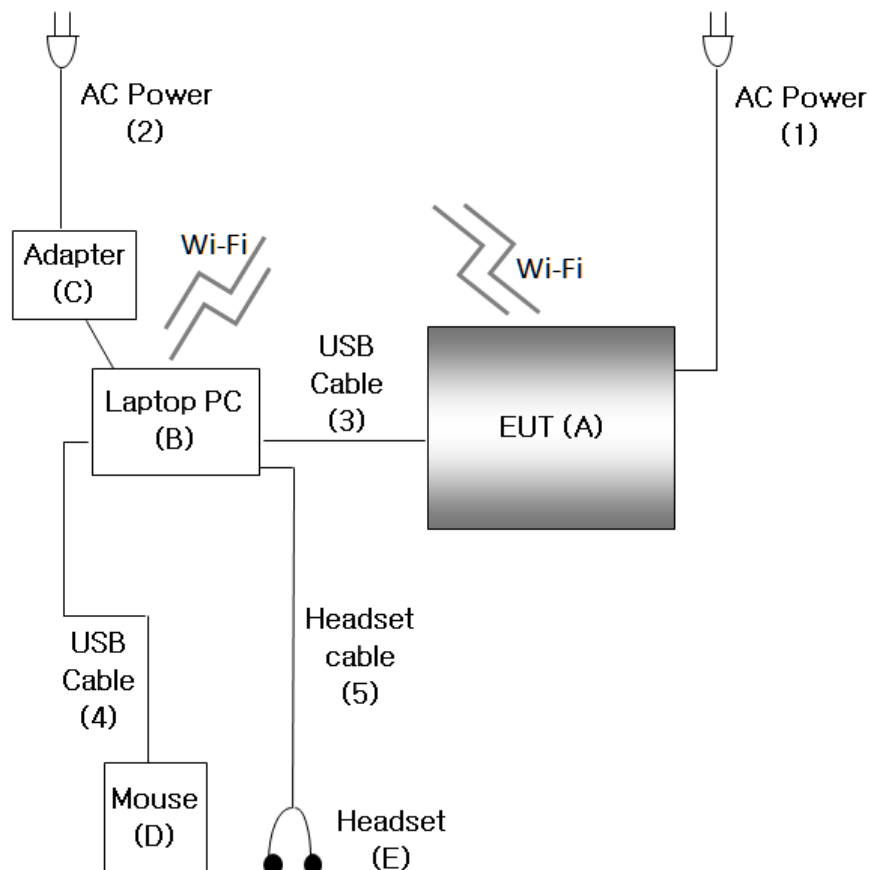

4.2 EUT operating mode

To achieve compliance applied standard specification, the following mode(s) were made during compliance testing:

Operating Mode 1	Standby
Operating Mode 2	1:99 scan copy printing
Operating Mode 3	Wireless printing
Operating Mode 4	USB printing
Operating Mode 5	Scan to PC

4.3 Details of Sampling

Customer selected, single unit.

4.4 Clock Frequencies

Kind of Clocks	Frequency[MHz]	Kind of Clocks	Frequency[MHz]
Main source clock	12	CPU internal clock	433
Video clock	23.571	USB device clock	12
DDR2 Clock	300	CIS	4

4.5 EUT Description

The following features describe EUT represented by this report:

Item	Specification and Description
Processor	CHORUS3-N (433Mhz)
Standard System memory	64MB DDR2 SDRAM
Resolution	1200 x 1200 dpi
Copy Quality mode	Text > Scan: 600x300dpi , Printing : 600x600dpi @ Platen Text/Photo > Scan: 600x300dpi , Printing : 600x600dpi @ Platen Photo > Scan: 600x600dpi , Printing : 1200x1200dpi @ Platen
Paper Handling	150-sheet Cassette @ 80g/m ² , 10-sheet @ Special Paper
Power Rating	110-127 VAC, 5A 50/60 Hz
Power Consumption	- . Power Save mode: 3.5W - . Printing Mode : 310W - . Ready Mode : 30W - . Off Mode : 0.45W
Printer Language	SPL
PC Interfaces	High speed USB2.0, 802.11 b/g/n
OS compatibility	Windows 2000/XP(32/64bits)/Vista(32/64bits)/2003 Server(32/64bits)/2008 Server(32/64bits)/7(32/64bits)/2008 Server R2(64bits) Mac OS X 10.4 ~ 10.6 RedHat Enterprise Linux WS 4, 5 (32/64 bit) Fedora 5, 6, 7, 8, 9, 10, 11, 12, 13 (32/64 bit) SuSE Linux 10.1 (32 bit) OpenSuSE 10.2, 10.3, 11.0, 11.1, 11.2 (32/64 bit) Mandriva 2007, 2008, 2009, 2009.1, 2010 (32/64 bit) Ubuntu 6.06, 6.10, 7.04, 7.10, 8.04, 8.10, 9.04, 9.10, 10.04 (32/64 bit) SuSE Linux Enterprise Desktop 10, 11 (32/64 bit) Debian 4.0, 5.0 (32/64 bit) Sun Solaris 9,10 (x86, SPARC) HP-UX 11.0, 11i v1, 11i v2, 11i v3 (PA-RISC, Itanium) IBM AIX 5.1, 5.2, 5.3, 5.4
Modes of Operation	USB Printing, Platen Scan, Platen Copy, Wireless
Intended Class for Emissions	Class B

4.6 Test configuration and condition

The system was configured for testing in typical fashion use. Cables were attached to each of the available I/O Ports. Where applicable, peripherals were attached to the I/O cables. The mode of operation utilized for testing was selected to best simulate typical EUT use.

The EUT was measured all testing with toner cartridge.

Power source for the EUT operating was supplied by CVCF made by the Pacific Corp.

- Test Voltage : AC 120 V, 60 Hz

4.7 Measurement uncertainty

Where relevant, the following measurement uncertainty levels have been estimated for tests performed on the apparatus: (According to CISPR 16-4 and UKAS Lab 34.)

4.7.1 Emission

Test type		Measurement uncertainty (C.L. 95 %, k = 2)
Conducted disturbance	Main terminal	3.30 dB
Radiated Disturbance (Below 1 GHz)	Horizontal	5.26 dB
	Vertical	5.27 dB
Radiated Disturbance (Above 1 GHz)	Horizontal	3.40 dB
	Vertical	3.12 dB

5. Results of individual test

5.1 Conducted disturbance

Both conducted lines are measured in Quasi-Peak and Average mode, including the worst-case data points for each tested configuration. The EUT measured in accordance with the methods described in standards.

Limits for conducted disturbance at the mains ports of class B ITE

Frequency range Limits MHz	Resolution Bandwidth	Limits dB μ V	
		Quasi-peak	Average
0.15 to 0.50	9 kHz	66 to 56	56 to 46
0.50 to 5	9 kHz	56	46
5 to 30	9 kHz	60	50
NOTE 1 The lower limit shall apply at the transition frequency			
NOTE 2 The limit decreases linearly with the logarithm of the frequency in the range 0.15 MHz to 0.50 MHz.			

5.1.1 Test instrumentation

Test instrumentation	Model name	Manufacturer	Serial or Firmware (No./Ver.)	Calibration	
				Date	Interval (Month)
Measuring receiver	ESIB26	R&S	100287	2011-07-30	12
Artificial mains network	ENV216	R&S	100117	2010-11-16	12
Artificial mains network	ESH3-Z5	R&S	100262	2010-09-27	12
Test software	EMC32	R&S	Ver 5.20.1	N/A	N/A

5.1.2 Temperature and humidity condition

Test date	September 02, 2011	Test engineer	Joung Jae Park		
Climate condition	Ambient temperature	24.1 °C	Relative humidity	34 %	
	Atmospheric pressure	101.0 kPa			
Test place	Shielded Room #1				

5.1.3 Photograph of Test Setup



Front



Rear

5.1.4 Test results (mains port)

Operating Mode 1 : Standby

Hardware Setup: Voltage with ENV 2-Line-LISN - [EMI conducted]

Subrange 1

Frequency Range: 150 kHz – 30 MHz

Receiver: ESIB 26

Transducer: ENV216 / Receiver-2-Line-LISN ENV216

Scan Setup: ITE_B_ENV 2-Line-LISN fin [EMI conducted]

Hardware Setup: Voltage with ENV 2-Line-LISN

Level Unit: dB μ V

Subrange	Detectors	IF Bandwidth	Meas. Time	Receiver
150 kHz – 30 MHz	Quasi Peak; Average	9 kHz	15 s	ESIB 26

Test Graph

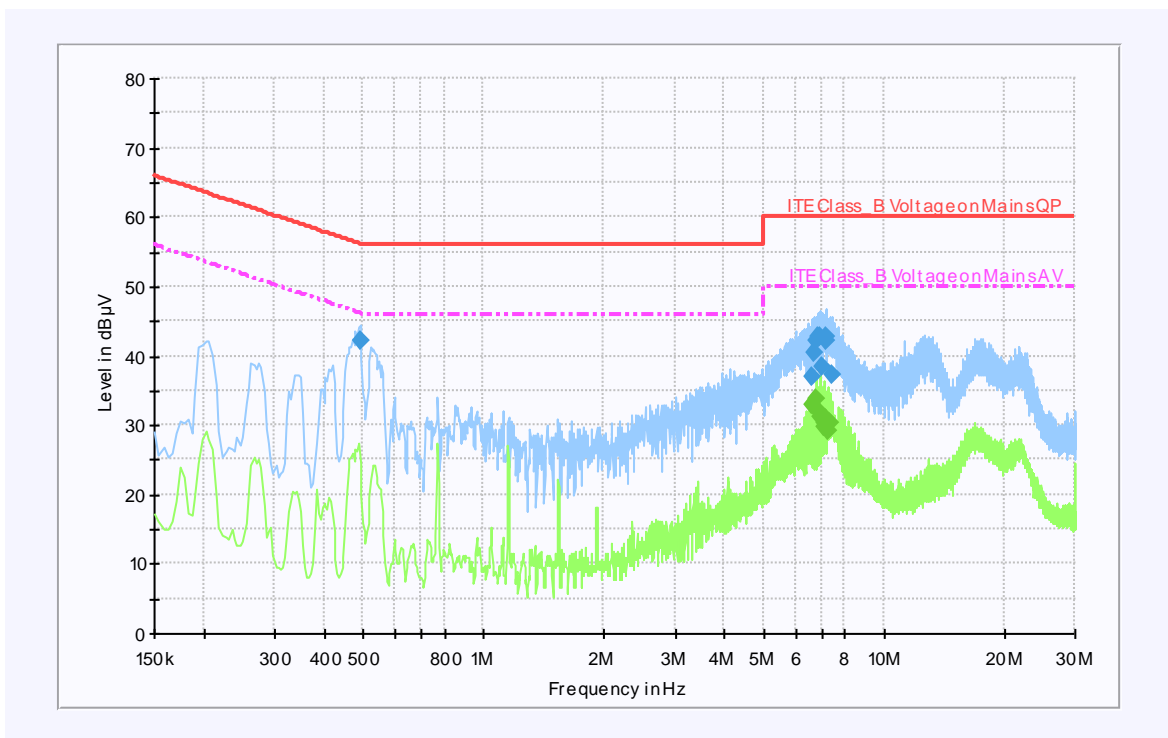

Note) Two graphs measured for both Live(L1) and Neutral(N) of the LISN are combined into one graph.

Test Results (Quasi-Peak and Average)

Quasi-peak final measurement results table

Frequency (MHz)	Level Quasi-Peak (dB μ V)	Line	Corr. (dB)	Margin (dB)	Limit (dB μ V)
0.490	42.2	L1	10.1	14.0	56.2
6.636	37.1	N	9.8	22.9	60.0
6.720	40.4	N	9.8	19.6	60.0
6.788	42.2	N	9.8	17.8	60.0
6.864	42.7	N	9.8	17.3	60.0
6.920	42.8	N	9.8	17.2	60.0
6.980	38.5	N	9.8	21.5	60.0
7.136	42.3	N	9.8	17.8	60.0
7.204	42.6	N	9.8	17.4	60.0
7.408	37.1	N	9.8	22.9	60.0

Average final measurement results table

Frequency (MHz)	Level Average (dB μ V)	Line	Corr. (dB)	Margin (dB)	Limit (dB μ V)
6.588	33.0	N	9.8	17.0	50.0
6.788	33.9	N	9.8	16.1	50.0
6.848	32.0	N	9.8	18.0	50.0
6.916	31.2	N	9.8	18.8	50.0
6.984	31.2	N	9.8	18.8	50.0
7.048	29.9	N	9.8	20.1	50.0
7.116	30.3	N	9.8	19.7	50.0
7.196	30.9	N	9.8	19.1	50.0
7.248	29.2	N	9.8	20.8	50.0
7.316	30.4	N	9.8	19.6	50.0

Note) Level (Quasi-Peak and/or Average) = Meter Reading (Quasi-Peak and/or Average) + Factor (LISN Insertion Loss + Cable Loss)

Margin = Limit – Level (Quasi-Peak and/or Average)

Operating Mode 2 : 1:99 scan copy printing

Hardware Setup: Voltage with ENV 2-Line-LISN - [EMI conducted]

Subrange 1
 Frequency Range: 150 kHz – 30 MHz
 Receiver: ESIB 26
 Transducer: ENV216 / Receiver-2-Line-LISN ENV216

Scan Setup: ITE_B_ENV 2-Line-LISN fin [EMI conducted]

Hardware Setup: Voltage with ENV 2-Line-LISN
 Level Unit: dB μ V

Subrange	Detectors	IF Bandwidth	Meas. Time	Receiver
150 kHz – 30 MHz	Quasi Peak; Average	9 kHz	15 s	ESIB 26

Test Graph

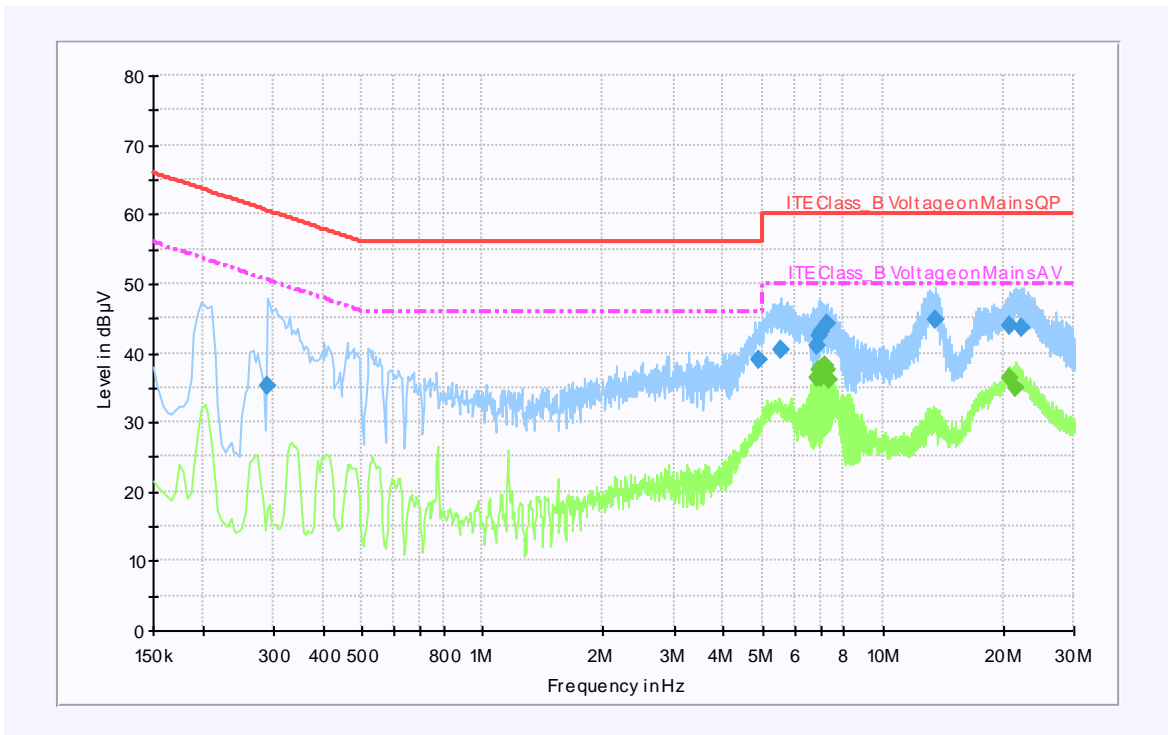

Note) Two graphs measured for both Live(L1) and Neutral(N) of the LISN are combined into one graph.

Test Results (Quasi-Peak and Average)

Quasi-peak final measurement results table

Frequency (MHz)	Quasi-Peak (dB μ V)	Line	Corr. (dB)	Margin (dB)	Limit (dB μ V)
0.290	35.4	L1	10.1	25.1	60.5
4.912	39.1	L1	9.8	16.9	56.0
5.544	40.3	L1	9.8	19.7	60.0
6.864	41.0	L1	9.8	19.0	60.0
6.932	42.6	L1	9.8	17.4	60.0
6.996	43.0	L1	9.8	17.0	60.0
7.216	44.3	N	9.8	15.7	60.0
13.544	44.7	N	10.0	15.3	60.0
20.660	43.9	L1	10.1	16.1	60.0
22.236	43.5	L1	10.1	16.5	60.0

Average final measurement results table

Frequency (MHz)	Average (dB μ V)	Line	Corr. (dB)	Margin (dB)	Limit (dB μ V)
6.876	36.4	N	9.8	13.6	50.0
6.944	37.6	N	9.8	12.4	50.0
7.012	36.3	N	9.8	13.7	50.0
7.072	37.7	N	9.8	12.3	50.0
7.136	38.1	N	9.8	11.9	50.0
7.204	38.2	N	9.8	11.8	50.0
7.268	37.4	N	9.8	12.6	50.0
7.332	36.2	N	9.8	13.8	50.0
20.764	36.3	L1	10.1	13.7	50.0
21.556	34.8	N	10.3	15.2	50.0

Note) Level (Quasi-Peak and/or Average) = Meter Reading (Quasi-Peak and/or Average) + Factor (LISN Insertion Loss + Cable Loss)

Margin = Limit – Level (Quasi-Peak and/or Average)

Operating Mode 3 : Wireless printing

Hardware Setup: Voltage with ENV 2-Line-LISN - [EMI conducted]

Subrange 1

Frequency Range: 150 kHz – 30 MHz
 Receiver: ESIB 26
 Transducer: ENV216 / Receiver-2-Line-LISN ENV216

Scan Setup: ITE_B_ENV 2-Line-LISN fin [EMI conducted]

Hardware Setup: Voltage with ENV 2-Line-LISN
 Level Unit: dB μ V

Subrange	Detectors	IF Bandwidth	Meas. Time	Receiver
150 kHz – 30 MHz	Quasi Peak; Average	9 kHz	15 s	ESIB 26

Test Graph

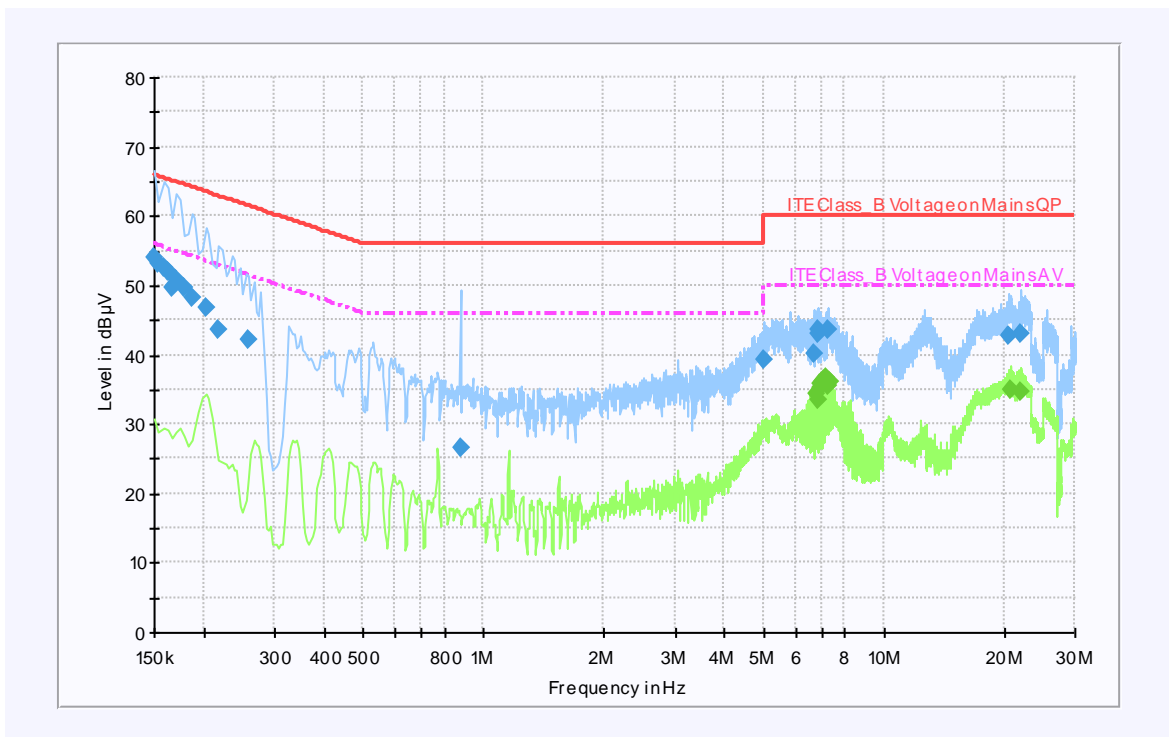

Note) Two graphs measured for both Live(L1) and Neutral(N) of the LISN are combined into one graph.

Test Results (Quasi-Peak and Average)

Quasi-peak final measurement results table

Frequency (MHz)	Quasi-Peak (dB μ V)	Line	Corr. (dB)	Margin (dB)	Limit (dB μ V)
0.150	54.1	L1	10.4	11.9	66.0
0.154	53.2	L1	10.0	12.6	65.8
0.158	52.7	L1	10.1	12.9	65.6
0.162	52.1	L1	10.2	13.3	65.4
0.166	49.6	L1	10.3	15.6	65.2
0.170	50.9	L1	10.3	14.1	65.0
0.178	49.6	L1	10.2	15.0	64.6
0.186	48.1	L1	10.2	16.1	64.2
0.202	46.7	L1	10.0	16.8	63.5
0.218	43.7	L1	10.0	19.2	62.9
0.258	42.1	L1	10.0	19.4	61.5
0.874	26.7	L1	10.0	29.3	56.0
4.996	39.4	L1	9.8	16.6	56.0
6.668	40.0	L1	9.8	20.0	60.0
6.808	43.7	N	9.8	16.3	60.0
6.876	43.0	N	9.8	17.0	60.0
7.220	43.6	N	9.8	16.4	60.0
20.576	42.8	L1	10.1	17.2	60.0
22.024	43.1	L1	10.1	16.9	60.0

Average final measurement results table

Frequency (MHz)	Average (dB μ V)	Line	Corr. (dB)	Margin (dB)	Limit (dB μ V)
6.756	34.5	N	9.8	15.5	50.0
6.824	33.4	N	9.8	16.6	50.0
6.888	35.1	N	9.8	14.9	50.0
6.956	35.9	N	9.8	14.1	50.0
7.020	36.2	N	9.8	13.8	50.0
7.084	36.3	N	9.8	13.7	50.0
7.148	36.7	N	9.8	13.3	50.0
7.216	36.1	N	9.8	13.9	50.0
7.280	35.4	N	9.8	14.6	50.0
7.344	36.1	N	9.8	13.9	50.0
20.748	34.9	L1	10.1	15.1	50.0
22.072	34.6	L1	10.1	15.4	50.0

Note) Level (Quasi-Peak and/or Average) = Meter Reading (Quasi-Peak and/or Average) + Factor (LISN Insertion Loss + Cable Loss)

Margin = Limit – Level (Quasi-Peak and/or Average)

Operating Mode 4 : USB printing

Hardware Setup: Voltage with ENV 2-Line-LISN - [EMI conducted]

Subrange 1
 Frequency Range: 150 kHz – 30 MHz
 Receiver: ESIB 26
 Transducer: ENV216 / Receiver-2-Line-LISN ENV216

Scan Setup: ITE_B_ENV 2-Line-LISN fin [EMI conducted]

Hardware Setup: Voltage with ENV 2-Line-LISN
 Level Unit: dB μ V

Subrange	Detectors	IF Bandwidth	Meas. Time	Receiver
150 kHz – 30 MHz	Quasi Peak; Average	9 kHz	15 s	ESIB 26

Test Graph

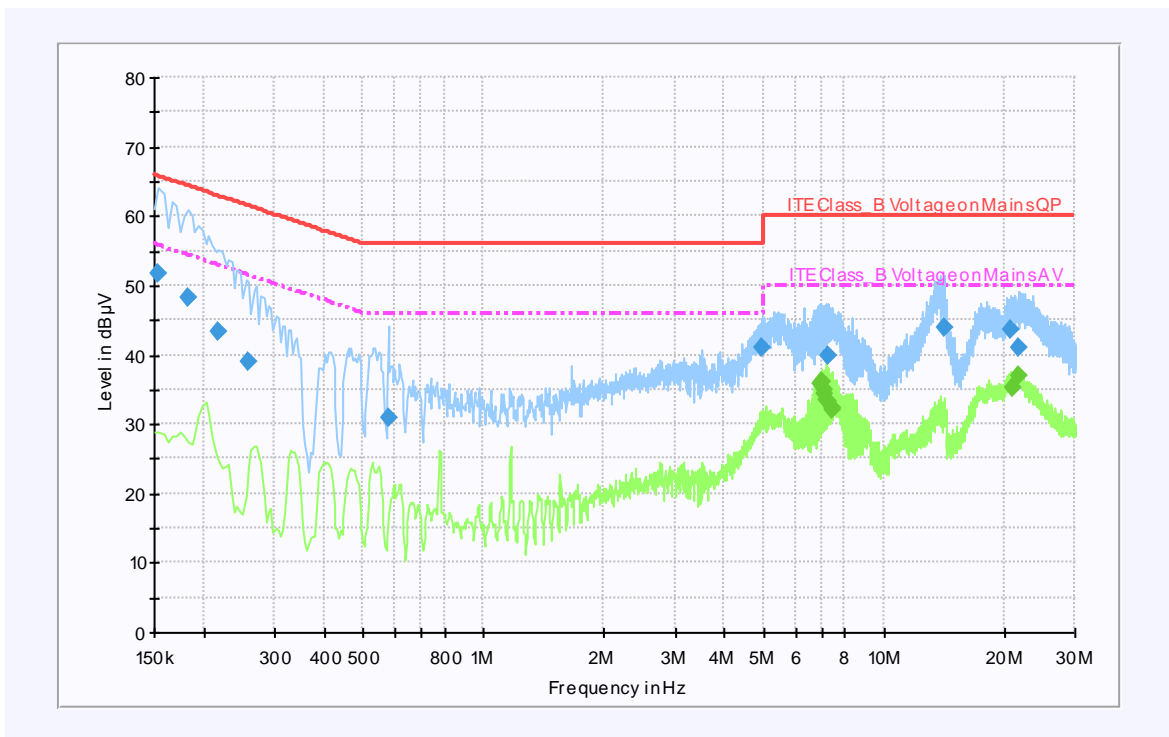

Note) Two graphs measured for both Live(L1) and Neutral(N) of the LISN are combined into one graph.

Test Results (Quasi-Peak and Average)

Quasi-peak final measurement results table

Frequency (MHz)	Quasi-Peak (dB μ V)	Line	Corr. (dB)	Margin (dB)	Limit (dB μ V)
0.154	51.7	N	10.0	14.1	65.8
0.182	48.3	N	10.2	16.1	64.4
0.218	43.4	N	10.0	19.5	62.9
0.258	38.9	N	10.0	22.6	61.5
0.578	31.0	N	10.1	25.0	56.0
4.932	40.9	N	9.8	15.1	56.0
7.248	40.0	N	9.8	20.0	60.0
14.092	43.9	N	10.1	16.1	60.0
20.840	43.7	L1	10.1	16.3	60.0
21.800	41.0	N	10.3	19.0	60.0

Average final measurement results table

Frequency (MHz)	Average (dB μ V)	Line	Corr. (dB)	Margin (dB)	Limit (dB μ V)
6.928	35.7	N	9.8	14.3	50.0
6.996	36.2	N	9.8	13.8	50.0
7.060	34.9	N	9.8	15.1	50.0
7.124	34.3	N	9.8	15.7	50.0
7.188	33.4	N	9.8	16.6	50.0
7.256	33.2	N	9.8	16.8	50.0
7.384	32.3	N	9.8	17.7	50.0
7.448	32.1	N	9.8	17.9	50.0
21.008	35.2	L1	10.1	14.8	50.0
21.744	36.9	L1	10.1	13.1	50.0

Note) Level (Quasi-Peak and/or Average) = Meter Reading (Quasi-Peak and/or Average) + Factor (LISN Insertion Loss + Cable Loss)

Margin = Limit – Level (Quasi-Peak and/or Average)

Operating Mode 5: Scan to PC

Hardware Setup: Voltage with ENV 2-Line-LISN - [EMI conducted]

Subrange 1
 Frequency Range: 150 kHz – 30 MHz
 Receiver: ESIB 26
 Transducer: ENV216 / Receiver-2-Line-LISN ENV216

Scan Setup: ITE_B_ENV 2-Line-LISN fin [EMI conducted]

Hardware Setup: Voltage with ENV 2-Line-LISN
 Level Unit: dB μ V

Subrange	Detectors	IF Bandwidth	Meas. Time	Receiver
150 kHz – 30 MHz	Quasi Peak; Average	9 kHz	15 s	ESIB 26

Test Graph

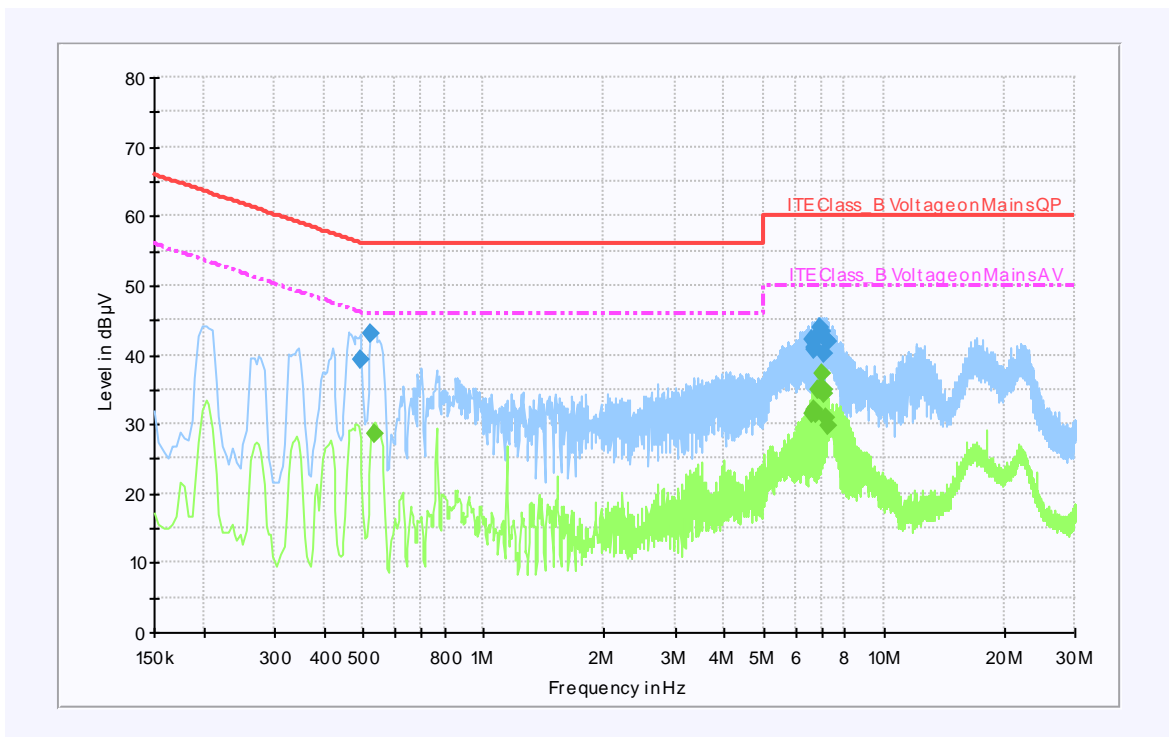

Note) Two graphs measured for both Live(L1) and Neutral(N) of the LISN are combined into one graph.

Test Results (Quasi-Peak and Average)

Quasi-peak final measurement results table

Frequency (MHz)	Quasi-Peak (dB μ V)	Line	Corr. (dB)	Margin (dB)	Limit (dB μ V)
0.490	39.2	N	10.1	17.0	56.2
0.522	43.1	L1	10.1	12.9	56.0
6.608	42.1	N	9.8	17.9	60.0
6.676	40.6	L1	9.8	19.4	60.0
6.716	41.1	N	9.8	18.9	60.0
6.812	42.5	N	9.8	17.5	60.0
6.872	42.6	N	9.8	17.4	60.0
6.940	44.0	N	9.8	16.0	60.0
7.008	43.5	N	9.8	16.5	60.0
7.072	40.1	N	9.8	19.9	60.0
7.144	42.2	N	9.8	17.8	60.0
7.284	42.0	N	9.8	18.0	60.0

Average final measurement results table

Frequency (MHz)	Average (dB μ V)	Line	Corr. (dB)	Margin (dB)	Limit (dB μ V)
0.534	28.5	L1	10.1	17.5	46.0
6.596	31.4	N	9.8	18.6	50.0
6.660	31.8	N	9.8	18.2	50.0
6.728	32.1	N	9.8	17.9	50.0
6.796	31.6	N	9.8	18.4	50.0
6.856	35.1	N	9.8	14.9	50.0
6.924	35.1	N	9.8	14.9	50.0
6.992	37.1	N	9.8	12.9	50.0
7.056	34.5	N	9.8	15.5	50.0
7.124	34.9	N	9.8	15.1	50.0
7.188	30.8	N	9.8	19.2	50.0
7.256	29.7	N	9.8	20.3	50.0

Note) Level (Quasi-Peak and/or Average) = Meter Reading (Quasi-Peak and/or Average) + Factor (LISN Insertion Loss + Cable Loss)

Margin = Limit – Level (Quasi-Peak and/or Average)

5.2 Radiated disturbance

Of those disturbances above ($L - 20$ dB), where L is the limit level in logarithmic units, record at least the disturbance levels and the frequencies of the six highest disturbances.

The following data lists the significant emission frequencies, measured levels, correction factors (for antenna and cables), orientation of table, polarization and height of antenna, the corrected reading, the limit, and the amount of margin. All measurements were taken utilizing quasi-peak detection unless stated otherwise.

Measurements were performed at an antenna to EUT distance of 10 m and elevated between 1 m and 4 m.

Both vertical and horizontal antenna polarizations were measured.

Limits for radiated disturbance of ITE at a measuring distance of 10 m

Frequency range Limits MHz	Resolution Bandwidth	Quasi-peak Limits dB μ V/m
		Class B
30 to 230	120 kHz	30
230 to 1 000	120 kHz	37
NOTE 1 The lower limit shall apply at the transition frequency		
NOTE 2 Additional provisions may be required for cases where interference occurs.		

Peak measurements were made over the changeable frequency range 1 GHz to 40 GHz or 5th in accordance with internal maximum operating frequency at a measurement distance of 3 m for the following antenna and turntable arrangements:

Antenna Height (cm)	Antenna Polarisation	Turntable position (degrees)
100 ~ 400	Horizontal, Vertical	Continuous

Above 1 GHz, peak detector function mode is used with a resolution bandwidth of 1 MHz and a video bandwidth of 1 MHz.

Limits for above 1 GHz radiated disturbance of ITE at a measuring distance of 3 m

Class	Limits - dB(μ V/m)	
	Peak	Average
B	74	54
Average limit 500, $20 \log 500 = 53.979 \text{ dB} \approx 54 \text{ dB}$		

Measurements within 20 dB of the limit were then maximized by adjusting turntable position. Final measurements were made using a average detector.

Results checked manually; and points close to the limit line were re-measured.

5.2.1 Test instrumentation

Test instrumentation	Model name	Manufacturer	Serial or Firmware (No./Ver.)	Calibration	
				Date	Interval (Month)
Bi-con Antenna	CBL6112D	Schaffner	22602	2010-04-21	24
Bi-con Antenna	CBL6112D	Schaffner	22248	2009-11-25	24
Test Receiver	ESCI	R&S	100369	2011-08-03	12
Test Receiver	ESCI	R&S	100370	2011-05-29	12
Horn Antenna	HF907	R&S	100016	2011-06-15	24
EMI Receiver	ESIB-26	R&S	100288	2011-06-16	12
Amplifier	310N	Agilent	185861	2011-04-07	12
Amplifier	310N	Agilent	251676	2011-04-07	12
Preamplifier	SCU_F018	R&S	10001	2011-04-10	12
Antenna Mast	MA4000	INN CO	N/A	N/A	N/A
Mast Controller	CO2000	INN CO	N/A	N/A	N/A
RF Selector	NS4900	TOYO	N/A	N/A	N/A
Test software	EP5/RE	TOYO	VER 3.1.20	N/A	N/A

5.2.2 Temperature and humidity condition

Test date	August 31, 2011 ~ September 05, 2011	Test engineer		Joung Jae Park	
Climate condition	Ambient temperature	24.1 °C	Relative humidity		33 %
	Atmospheric pressure	100.9 kPa			
Test place	10 m Semi-Anechoic Chamber				

5.2.3 Photograph of Test Setup

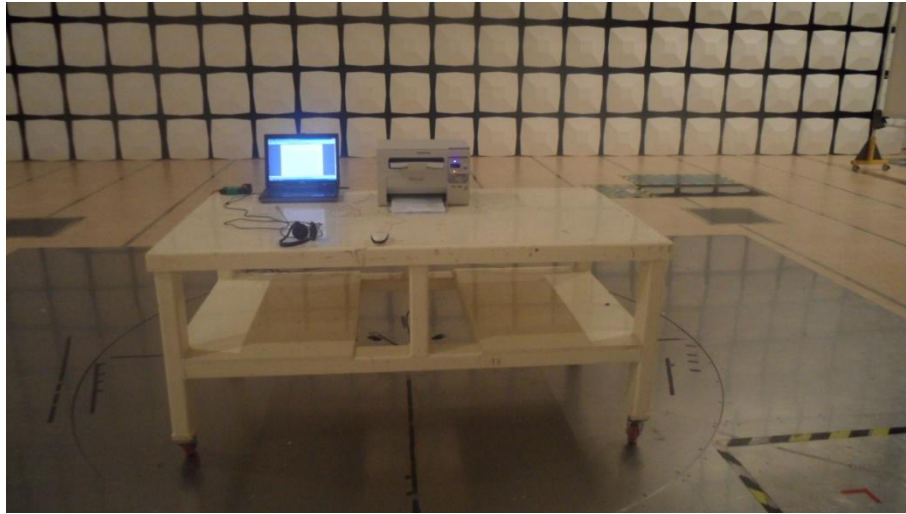

Front (Below 1 GHz)

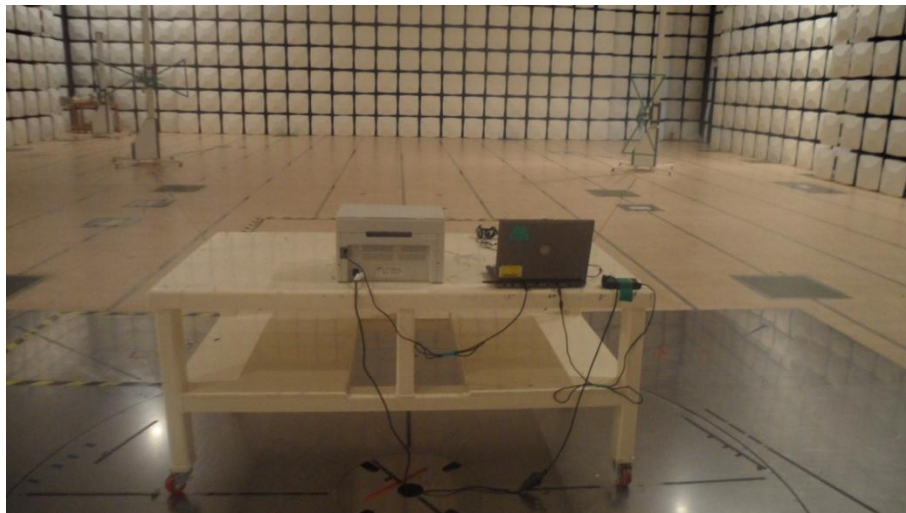

Rear (Below 1 GHz)

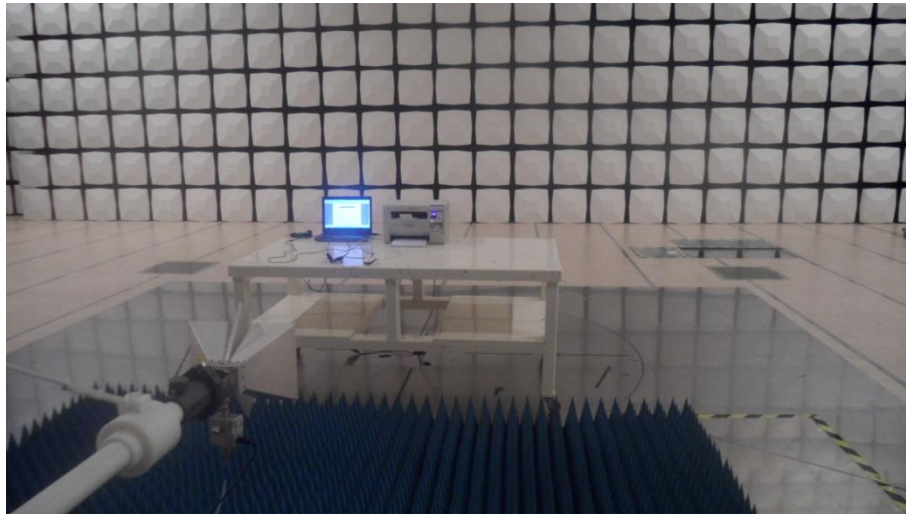

Front (above 1 GHz)

5.2.4 Test results

Operating Mode 1 : Standby

Test Graph and Results

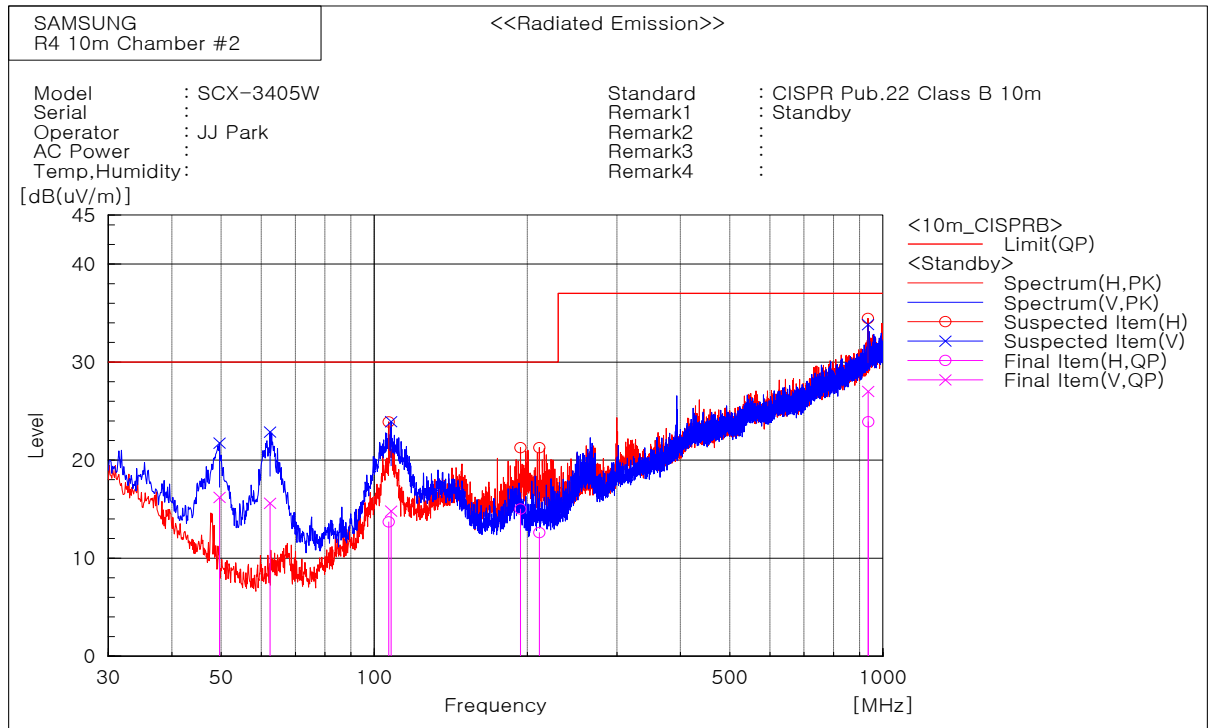

Frequency [MHz]	PO L	Reading QP [dB(μV)]	Factor [dB(1/m)]	Level QP [dB(μV/m)]	Limit [dB(μV/m)]	Margin QP [dB]	Height [cm]	Angle [deg]
49.643	V	38.9	-22.7	16.2	30.0	13.8	100.0	333.5
62.374	V	40.0	-24.4	15.6	30.0	14.4	300.0	358.4
106.751	H	31.1	-17.4	13.7	30.0	16.3	400.0	312.6
107.964	V	32.4	-17.6	14.8	30.0	15.2	200.0	271.6
193.930	H	33.9	-18.9	15.0	30.0	15.0	400.0	321.5
211.148	H	31.3	-18.7	12.6	30.0	17.4	400.0	195.3
935.344	V	28.2	-1.2	27.0	37.0	10.0	174.0	347.3
936.250	H	25.0	-1.1	23.9	37.0	13.1	109.0	132.4

Note) Receiving antenna polarization : Horizontal and/or Vertical
 Test Distance : 10 m, Antenna Height : 1 m to 4 m
 Level QP (Quasi-Peak) = Reading QP + Factor (Antenna Factor + Cable Loss - Amp. Gain)
 Margin QP (Quasi-Peak) = Limit - Level QP

Peak Measurement

Frequency [MHz]	POL	Reading PK [dB(uV)]	Factor [dB(1/m)]	Level PK [dB(uV/m)]	Limit [dB(uV/m)]	Margin PK [dB]	Height [cm]	Angle [deg]
1030.060	V	66.2	-13.7	52.5	70.0	17.5	100.0	305.8
1055.110	H	64.2	-13.6	50.6	70.0	19.4	100.0	64.4
1060.120	V	65.2	-13.6	51.6	70.0	18.4	100.0	225.0
1235.471	H	63.0	-13.1	49.9	70.0	20.1	100.0	64.4
1235.471	V	63.0	-13.1	49.9	70.0	20.1	100.0	356.0
1325.651	V	64.7	-13.0	51.7	70.0	18.3	100.0	30.1
1375.752	V	63.9	-12.9	51.0	70.0	19.0	100.0	345.8
1425.852	V	65.5	-12.8	52.7	70.0	17.3	100.0	92.0
1596.192	H	63.1	-11.0	52.1	70.0	17.9	100.0	329.4
1601.202	V	65.4	-10.9	54.5	70.0	15.5	100.0	349.3
1656.313	H	66.2	-10.6	55.6	70.0	14.4	100.0	24.4
1661.323	V	65.7	-10.6	55.1	70.0	14.9	100.0	318.6
1726.453	H	68.0	-10.5	57.5	70.0	12.5	100.0	309.7
1726.453	V	66.9	-10.5	56.4	70.0	13.6	100.0	0.3
2377.756	V	59.3	-7.7	51.6	70.0	18.4	100.0	351.8
2538.076	V	60.5	-6.0	54.5	70.0	15.5	100.0	200.3
2618.237	V	58.2	-5.7	52.5	70.0	17.5	100.0	25.2
2933.868	V	55.1	-4.8	50.3	70.0	19.7	100.0	0.3
2993.988	V	55.7	-4.2	51.5	70.0	18.5	100.0	341.2

Average Measurement

Frequency [MHz]	POL	Reading AV [dB(uV)]	Factor [dB(1/m)]	Level AV [dB(uV/m)]	Limit [dB(uV/m)]	Margin AV [dB]	Height [cm]	Angle [deg]
1030.935	V	30.2	-13.7	16.5	50.0	33.5	100.0	6.6
1055.861	H	30.9	-13.6	17.3	50.0	32.7	100.0	356.9
1060.112	V	30.9	-13.6	17.3	50.0	32.7	100.0	353.3
1235.050	V	32.9	-13.1	19.8	50.0	30.2	100.0	184.1
1235.100	H	33.0	-13.1	19.9	50.0	30.1	100.0	27.4
1327.659	V	32.4	-12.9	19.5	50.0	30.5	100.0	27.0
1374.010	V	31.4	-12.9	18.5	50.0	31.5	100.0	114.7
1424.800	V	32.3	-12.8	19.5	50.0	30.5	100.0	52.4
1598.635	H	28.7	-10.9	17.8	50.0	32.2	100.0	286.4
1600.591	V	30.5	-10.9	19.6	50.0	30.4	100.0	294.3
1658.023	V	32.1	-10.6	21.5	50.0	28.5	100.0	318.0
1661.523	H	32.9	-10.6	22.3	50.0	27.7	100.0	327.3
1725.946	H	31.7	-10.5	21.2	50.0	28.8	100.0	21.2
1725.148	V	29.7	-10.5	19.2	50.0	30.8	100.0	356.4
2376.353	V	27.4	-7.7	19.7	50.0	30.3	100.0	40.7

2538.778	V	28.7	-6.0	22.7	50.0	27.3	100.0	7.9
2616.859	V	28.1	-5.7	22.4	50.0	27.6	100.0	174.0
2932.034	V	27.5	-4.9	22.6	50.0	27.4	100.0	317.9
2995.100	V	35.7	-4.2	31.5	50.0	18.5	100.0	339.2

Note1) Any emissions that do NOT exceed average limit were not tested with average detector mode.

Note2) Receiving antenna polarization : Horizontal and Vertical

Level P K(Peak) = Reading PK(Peak) + Factor(Antenna Factor + Cable Loss - Amp. Gain)

Level AV (Average) = Reading AV (Average) + Factor(Antenna Factor + Cable Loss - Amp. Gain)

Margin PK (Peak) = Limit – Level PK (Peak)

Margin AV (Average) = Limit – Level AV (Average)

Note3) No peak emissions which exceeded the average limit were detected above 5 GHz.



Operating Mode 2 : 1:99 scan copy printing

Test Graph and Results

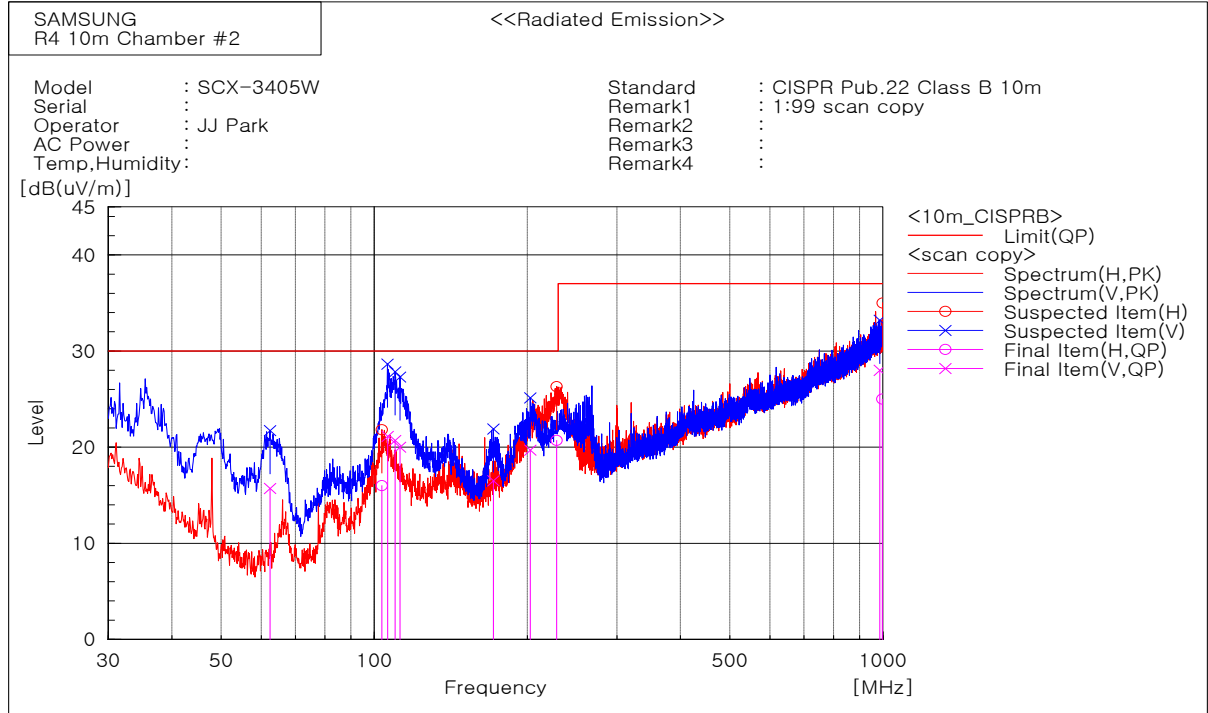

Frequency [MHz]	PO L	Reading QP [dB(µV)]	Factor [dB(1/m)]	Level QP [dB(µV/m)]	Limit [dB(µV/m)]	Margin QP[dB]	Height [cm]	Angle [deg]
62.374	V	40.1	-24.4	15.7	30.0	14.3	301.0	339.3
103.478	H	33.8	-17.8	16.0	30.0	14.0	400.0	311.6
106.258	V	38.9	-17.8	21.1	30.0	8.9	138.0	289.6
109.904	V	38.1	-17.4	20.7	30.0	9.3	100.0	0.7
112.329	V	37.1	-17.1	20.0	30.0	10.0	100.0	0.7
171.499	V	35.8	-19.3	16.5	30.0	13.5	100.0	43.1
202.660	V	39.3	-19.6	19.7	30.0	10.3	100.0	84.4
228.365	H	38.3	-17.6	20.7	30.0	9.3	400.0	39.9
985.814	V	28.2	-0.2	28.0	37.0	9.0	301.0	354.2
997.405	H	24.8	0.2	25.0	37.0	12.0	106.0	163.7

Note) Receiving antenna polarization : Horizontal and/or Vertical

Test Distance : 10 m, Antenna Height : 1 m to 4 m

Level QP (Quasi-Peak) = Reading QP + Factor (Antenna Factor + Cable Loss - Amp. Gain)

Margin QP (Quasi-Peak) = Limit - Level QP

Peak Measurement

Frequency [MHz]	POL	Reading PK [dB(uV)]	Factor [dB(1/m)]	Level PK [dB(uV/m)]	Limit [dB(uV/m)]	Margin PK [dB]	Height [cm]	Angle [deg]
1330.661	V	64.4	-12.9	51.5	70.0	18.5	100.0	26.5
1656.313	H	65.6	-10.6	55.0	70.0	15.0	100.0	20.7
1661.323	V	66.6	-10.6	56.0	70.0	14.0	100.0	257.8
2297.595	H	57.3	-8.2	49.1	70.0	20.9	100.0	90.8
2377.756	H	58.6	-7.7	50.9	70.0	19.1	100.0	84.0
2377.756	V	58.4	-7.7	50.7	70.0	19.3	100.0	31.5
2543.086	V	58.9	-6.0	52.9	70.0	17.1	100.0	324.9
2658.317	H	56.7	-5.8	50.9	70.0	19.1	100.0	108.6
2993.988	V	55.6	-4.2	51.4	70.0	18.6	100.0	335.7

Average Measurement

Frequency [MHz]	POL	Reading AV [dB(uV)]	Factor [dB(1/m)]	Level AV [dB(uV/m)]	Limit [dB(uV/m)]	Margin AV [dB]	Height [cm]	Angle [deg]
1330.473	V	36.5	-12.9	23.6	50.0	26.4	100.0	20.1
1656.397	H	32.5	-10.6	21.9	50.0	28.1	100.0	293.0
1662.091	V	30.0	-10.6	19.4	50.0	30.6	100.0	286.8
2297.672	H	30.2	-8.2	22.0	50.0	28.0	100.0	89.7
2377.506	V	31.2	-7.7	23.5	50.0	26.5	100.0	78.3
2377.872	H	32.0	-7.7	24.3	50.0	25.7	100.0	291.2
2542.800	V	32.0	-6.0	26.0	50.0	24.0	100.0	57.8
2657.948	H	28.2	-5.8	22.4	50.0	27.6	100.0	191.7
2993.802	V	25.1	-4.2	20.9	50.0	29.1	100.0	5.2

Note1) Any emissions that do NOT exceed average limit were not tested with average detector mode.

Note2) Receiving antenna polarization : Horizontal and Vertical

Level P K(Peak) = Reading PK(Peak) + Factor(Antenna Factor + Cable Loss - Amp. Gain)

Level AV (Average) = Reading AV (Average) + Factor(Antenna Factor + Cable Loss - Amp. Gain)

Margin PK (Peak) = Limit – Level PK (Peak)

Margin AV (Average) = Limit – Level AV (Average)

Note3) No peak emissions which exceeded the average limit were detected above 5 GHz.



Operating Mode 3 : Wireless printing

Test Graph and Results

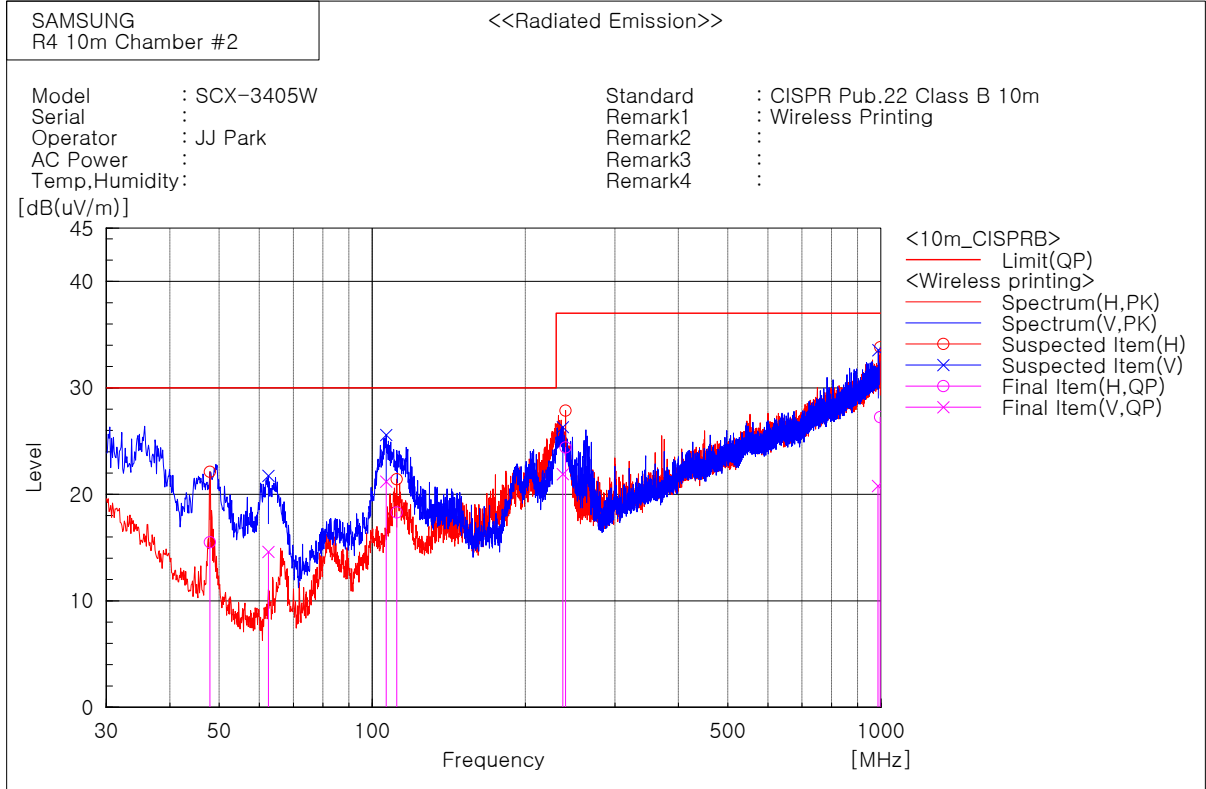

Frequency [MHz]	PO L	Reading QP [dB(μV)]	Factor [dB(1/m)]	Level QP [dB(μV/m)]	Limit [dB(μV/m)]	Margin QP[dB]	Height [cm]	Angle [deg]
47.945	H	37.0	-21.5	15.5	30.0	14.5	400.0	253.8
62.495	V	39.1	-24.5	14.6	30.0	15.4	300.0	314.7
106.509	V	39.0	-17.8	21.2	30.0	8.8	400.0	185.6
111.723	H	35.2	-16.9	18.3	30.0	11.7	400.0	287.3
236.974	V	39.6	-17.7	21.9	37.0	15.1	100.0	17.4
240.005	H	40.7	-16.3	24.4	37.0	12.6	301.0	270.3
986.891	V	20.9	-0.1	20.8	37.0	16.2	140.0	352.3
996.922	H	27.1	0.2	27.3	37.0	9.7	100.0	139.9

Note) Receiving antenna polarization : Horizontal and/or Vertical
 Test Distance : 10 m, Antenna Height : 1 m to 4 m
 Level QP (Quasi-Peak) = Reading QP + Factor (Antenna Factor + Cable Loss - Amp. Gain)
 Margin QP (Quasi-Peak) = Limit – Level QP

Peak Measurement

Frequency [MHz]	POL	Reading PK [dB(uV)]	Factor [dB(1/m)]	Level PK [dB(uV/m)]	Limit [dB(uV/m)]	Margin PK [dB]	Height [cm]	Angle [deg]
1030.060	V	64.6	-13.7	50.9	70.0	19.1	100.0	2.5
1055.110	V	68.3	-13.6	54.7	70.0	15.3	100.0	0.3
1055.110	H	68.3	-13.6	54.7	70.0	15.3	100.0	353.3
1130.261	V	63.4	-13.3	50.1	70.0	19.9	100.0	282.6
1420.842	H	65.9	-12.8	53.1	70.0	16.9	100.0	340.1
1596.192	H	64.9	-11.0	53.9	70.0	16.1	100.0	332.2
1596.192	V	64.9	-11.0	53.9	70.0	16.1	100.0	55.2
1661.323	V	70.1	-10.6	59.5	70.0	10.5	100.0	289.5
1661.323	H	65.1	-10.6	54.5	70.0	15.5	100.0	304.7
1721.443	V	67.5	-10.5	57.0	70.0	13.0	100.0	357.8
1726.453	H	64.6	-10.5	54.1	70.0	15.9	100.0	307.6
1771.543	V	60.5	-10.3	50.2	70.0	19.8	100.0	351.2
1796.593	V	60.8	-10.2	50.6	70.0	19.4	100.0	356.8
2377.756	V	59.1	-7.7	51.4	70.0	18.6	100.0	82.8
2382.766	H	57.5	-7.6	49.9	70.0	20.1	100.0	70.4
2543.086	V	58.6	-6.0	52.6	70.0	17.4	100.0	170.4
4876.754	H	53.3	2.9	56.2	70.0	13.8	100.0	228.4
4885.772	V	57.1	2.9	60.0	70.0	10.0	100.0	352.1
4936.874	V	50.9	3.2	54.1	70.0	15.9	100.0	32.5

Average Measurement

Frequency [MHz]	POL	Reading AV [dB(uV)]	Factor [dB(1/m)]	Level AV [dB(uV/m)]	Limit [dB(uV/m)]	Margin AV [dB]	Height [cm]	Angle [deg]
1029.055	V	34.6	-13.7	20.9	50.0	29.1	100.0	165.0
1054.693	H	36.9	-13.6	23.3	50.0	26.7	100.0	358.1
1055.368	V	38.1	-13.6	24.5	50.0	25.5	100.0	6.1
1129.060	V	34.4	-13.3	21.1	50.0	28.9	100.0	282.6
1421.040	H	29.4	-12.8	16.6	50.0	33.4	100.0	17.4
1560.002	H	29.9	-11.3	18.6	50.0	31.4	100.0	5.5
1597.332	V	32.1	-10.9	21.2	50.0	28.8	100.0	253.8
1661.030	H	30.9	-10.6	20.3	50.0	29.7	100.0	155.5
1661.367	V	23.7	-10.6	13.1	50.0	36.9	100.0	317.1
1722.036	V	35.1	-10.5	24.6	50.0	25.4	100.0	47.5
1727.335	H	29.5	-10.5	19.0	50.0	31.0	100.0	2.3
1772.003	V	28.2	-10.3	17.9	50.0	32.1	100.0	339.0
1797.500	V	29.7	-10.2	19.5	50.0	30.5	100.0	354.1
2378.056	V	26.0	-7.7	18.3	50.0	31.7	100.0	43.1
2381.760	H	24.0	-7.6	16.4	50.0	33.6	100.0	55.4

2541.003	V	26.4	-6.0	20.4	50.0	29.6	100.0	99.1
4877.034	H	24.2	2.9	27.1	54.0	26.9	100.0	17.5
4885.788	V	21.4	2.9	24.3	54.0	29.7	100.0	82.6
4937.404	V	21.7	3.2	24.9	54.0	29.1	100.0	50.5

Note1) Any emissions that do NOT exceed average limit were not tested with average detector mode.

Note2) Receiving antenna polarization : Horizontal and Vertical

Level P K(Peak) = Reading PK(Peak) + Factor(Antenna Factor + Cable Loss - Amp. Gain)

Level AV (Average) = Reading AV (Average) + Factor(Antenna Factor + Cable Loss - Amp. Gain)

Margin PK (Peak) = Limit – Level PK (Peak)

Margin AV (Average) = Limit – Level AV (Average)

Note3) No peak emissions which exceeded the average limit were detected above 5 GHz.



Operating Mode 4 : USB printing

Test Graph and Results

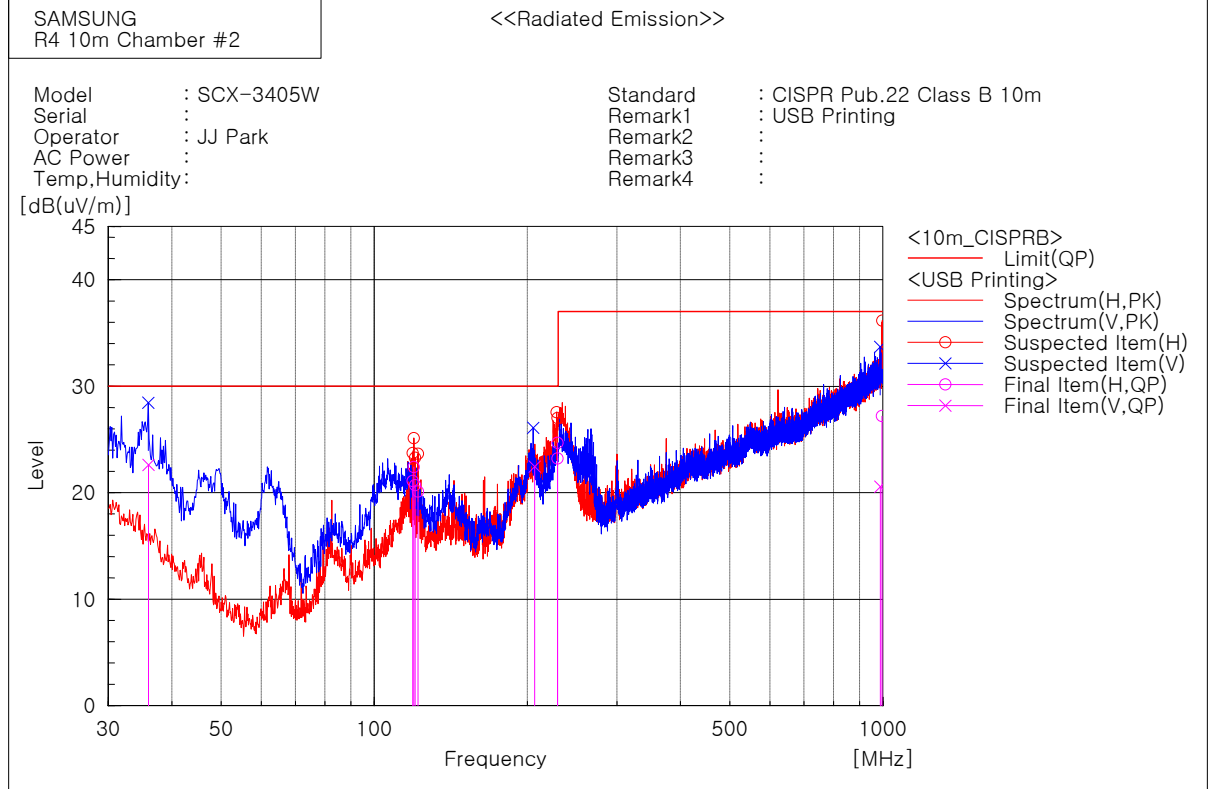

Frequency [MHz]	PO L	Reading QP [dB(μV)]	Factor [dB(1/m)]	Level QP [dB(μV/m)]	Limit [dB(μV/m)]	Margin QP[dB]	Height [cm]	Angle [deg]
35.975	V	38.6	-16.0	22.6	30.0	7.4	100.0	99.1
118.998	H	37.8	-16.7	21.1	30.0	8.9	298.0	308.3
119.604	H	39.1	-16.7	22.4	30.0	7.6	400.0	107.3
120.331	H	37.4	-16.7	20.7	30.0	9.3	298.0	332.9
121.908	H	36.8	-16.7	20.1	30.0	9.9	400.0	279.3
206.777	V	41.6	-19.1	22.5	30.0	7.5	106.0	238.9
229.335	H	40.7	-17.5	23.2	30.0	6.8	400.0	90.5
229.391	H	42.2	-17.5	24.7	30.0	5.3	397.0	89.2
988.931	V	20.7	-0.1	20.6	37.0	16.4	302.0	133.6
996.072	H	27.0	0.2	27.2	37.0	9.8	293.0	354.8

Note) Receiving antenna polarization : Horizontal and/or Vertical

Test Distance : 10 m, Antenna Height : 1 m to 4 m

Level QP (Quasi-Peak) = Reading QP + Factor (Antenna Factor + Cable Loss - Amp. Gain)

Margin QP (Quasi-Peak) = Limit - Level QP

Peak Measurement

Frequency [MHz]	POL	Reading PK [dB(uV)]	Factor [dB(1/m)]	Level PK [dB(uV/m)]	Limit [dB(uV/m)]	Margin PK [dB]	Height [cm]	Angle [deg]
1055.110	V	65.9	-13.6	52.3	70.0	17.7	100.0	2.1
1060.120	H	66.4	-13.6	52.8	70.0	17.2	100.0	354.8
1140.281	V	66.0	-13.2	52.8	70.0	17.2	100.0	290.4
1330.661	V	63.1	-12.9	50.2	70.0	19.8	100.0	166.9
1330.661	H	62.7	-12.9	49.8	70.0	20.2	100.0	349.7
1420.842	V	62.6	-12.8	49.8	70.0	20.2	100.0	302.3
1596.192	H	66.5	-11.0	55.5	70.0	14.5	100.0	307.4
1601.202	V	63.4	-10.9	52.5	70.0	17.5	100.0	320.1
1656.313	V	68.3	-10.6	57.7	70.0	12.3	100.0	290.4
1661.323	H	69.7	-10.6	59.1	70.0	10.9	100.0	330.1
1696.393	H	60.4	-10.5	49.9	70.0	20.1	100.0	330.1
1721.443	H	67.4	-10.5	56.9	70.0	13.1	100.0	305.4
1726.453	V	65.6	-10.5	55.1	70.0	14.9	100.0	3.2
1801.603	V	61.6	-10.2	51.4	70.0	18.6	100.0	334.9
2377.756	V	59.8	-7.7	52.1	70.0	17.9	100.0	67.3
2538.076	V	60.1	-6.0	54.1	70.0	15.9	100.0	176.9
2618.237	V	56.4	-5.7	50.7	70.0	19.3	100.0	49.5
2928.858	V	54.8	-4.9	49.9	70.0	20.1	100.0	334.9
2998.998	V	54.5	-4.2	50.3	70.0	19.7	100.0	317.1

Average Measurement

Frequency [MHz]	POL	Reading AV [dB(uV)]	Factor [dB(1/m)]	Level AV [dB(uV/m)]	Limit [dB(uV/m)]	Margin AV [dB]	Height [cm]	Angle [deg]
1054.007	V	33.1	-13.6	19.5	50.0	30.5	100.0	15.4
1058.450	H	35.7	-13.6	22.1	50.0	27.9	100.0	45.0
1142.330	V	31.8	-13.2	18.6	50.0	31.4	100.0	150.0
1331.051	H	31.5	-12.9	18.6	50.0	31.4	100.0	25.4
1331.226	V	33.2	-12.9	20.3	50.0	29.7	100.0	155.5
1421.040	V	33.7	-12.8	20.9	50.0	29.1	100.0	0.3
1594.120	H	30.6	-11.0	19.6	50.0	30.4	100.0	155.5
1600.002	V	31.0	-10.9	20.1	50.0	29.9	100.0	120.5
1657.026	V	32.7	-10.6	22.1	50.0	27.9	100.0	319.3
1661.975	H	30.0	-10.6	19.4	50.0	30.6	100.0	26.2
1694.380	H	31.6	-10.5	21.1	50.0	28.9	100.0	350.1
1723.002	H	32.1	-10.5	21.6	50.0	28.4	100.0	250.4
1727.554	V	32.1	-10.5	21.6	50.0	28.4	100.0	3.2
1800.554	V	30.6	-10.2	20.4	50.0	29.6	100.0	300.5
2375.446	V	25.3	-7.7	17.6	50.0	32.4	100.0	57.4

2540.113	V	26.1	-6.0	20.1	50.0	29.9	100.0	55.5
2617.220	V	25.6	-5.7	19.9	50.0	30.1	100.0	65.5
2930.008	V	25.0	-4.9	20.1	50.0	29.9	100.0	354.6
3000.998	V	25.8	-4.2	21.6	54.0	32.4	100.0	355.0

Note1) Any emissions that do NOT exceed average limit were not tested with average detector mode.

Note2) Receiving antenna polarization : Horizontal and Vertical

Level P K(Peak) = Reading PK(Peak) + Factor(Antenna Factor + Cable Loss - Amp. Gain)

Level AV (Average) = Reading AV (Average) + Factor(Antenna Factor + Cable Loss - Amp. Gain)

Margin PK (Peak) = Limit – Level PK (Peak)

Margin AV (Average) = Limit – Level AV (Average)

Note3) No peak emissions which exceeded the average limit were detected above 5 GHz.



Operating Mode 5 : Scan to PC

Test Graph and Results

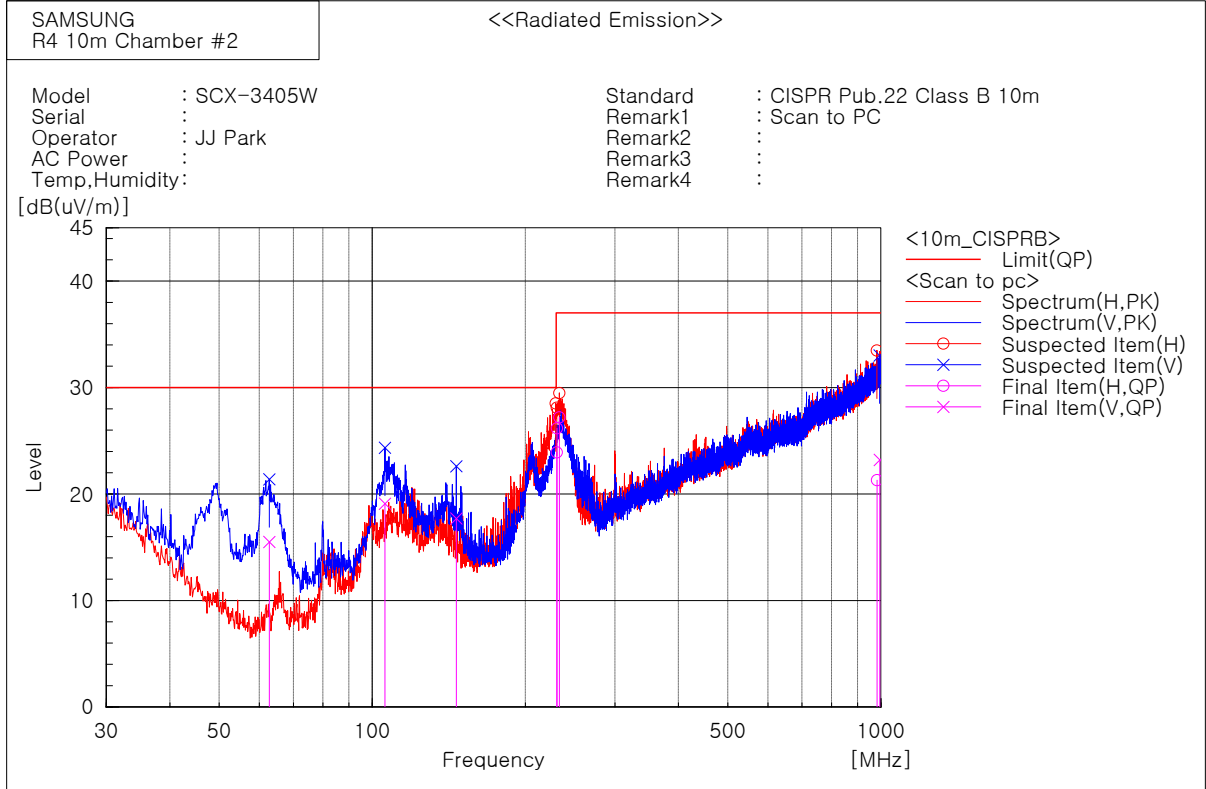

Frequency [MHz]	PO L	Reading QP [dB(μV)]	Factor [dB(1/m)]	Level QP [dB(μV/m)]	Limit [dB(μV/m)]	Margin QP[dB]	Height [cm]	Angle [deg]
62.738	V	40.0	-24.5	15.5	30.0	14.5	301.0	349.2
105.903	V	37.0	-17.9	19.1	30.0	10.9	100.0	1.6
146.279	V	36.0	-18.3	17.7	30.0	12.3	301.0	349.2
230.548	H	41.2	-17.3	23.9	37.0	13.1	400.0	74.5
230.816	H	43.5	-17.3	26.2	37.0	10.8	400.0	95.8
233.336	H	44.2	-17.0	27.2	37.0	9.8	400.0	82.5
982.601	H	21.3	0.0	21.3	37.0	15.7	111.0	134.0
994.745	V	23.2	0.0	23.2	37.0	13.8	201.0	152.5

Note) Receiving antenna polarization : Horizontal and/or Vertical
 Test Distance : 10 m, Antenna Height : 1 m to 4 m
 Level QP (Quasi-Peak) = Reading QP + Factor (Antenna Factor + Cable Loss - Amp. Gain)
 Margin QP (Quasi-Peak) = Limit - Level QP

Peak Measurement

Frequency [MHz]	POL	Reading PK [dB(uV)]	Factor [dB(1/m)]	Level PK [dB(uV/m)]	Limit [dB(uV/m)]	Margin PK [dB]	Height [cm]	Angle [deg]
1596.192	V	60.4	-11.0	49.4	70.0	20.6	100.0	297.0
1661.323	V	69.2	-10.6	58.6	70.0	11.4	100.0	321.6
1661.323	H	69.0	-10.6	58.4	70.0	11.6	100.0	336.7
2382.766	V	58.6	-7.6	51.0	70.0	19.0	100.0	66.6
1596.192	V	60.4	-11.0	49.4	70.0	20.6	100.0	297.0
2538.076	V	60.6	-6.0	54.6	70.0	15.4	100.0	167.0

Average Measurement

Frequency [MHz]	POL	Reading AV [dB(uV)]	Factor [dB(1/m)]	Level AV [dB(uV/m)]	Limit [dB(uV/m)]	Margin AV [dB]	Height [cm]	Angle [deg]
1596.886	V	28.6	-10.9	17.7	50.0	32.3	100.0	297.5
1661.018	H	28.3	-10.6	17.7	50.0	32.3	100.0	304.8
1661.250	V	28.7	-10.6	18.1	50.0	31.9	100.0	319.9
2382.030	V	24.2	-7.6	16.6	50.0	33.4	100.0	172.3
2537.922	V	25.2	-6.0	19.2	50.0	30.8	100.0	81.8

Note1) Any emissions that do NOT exceed average limit were not tested with average detector mode.

Note2) Receiving antenna polarization : Horizontal and Vertical

Level P K(Peak) = Reading PK(Peak) + Factor(Antenna Factor + Cable Loss - Amp. Gain)

Level AV (Average) = Reading AV (Average) + Factor(Antenna Factor + Cable Loss - Amp. Gain)

Margin PK (Peak) = Limit – Level PK (Peak)

Margin AV (Average) = Limit – Level AV (Average)

Note3) No peak emissions which exceeded the average limit were detected above 5 GHz.

Appendix – EUT photography



Front View

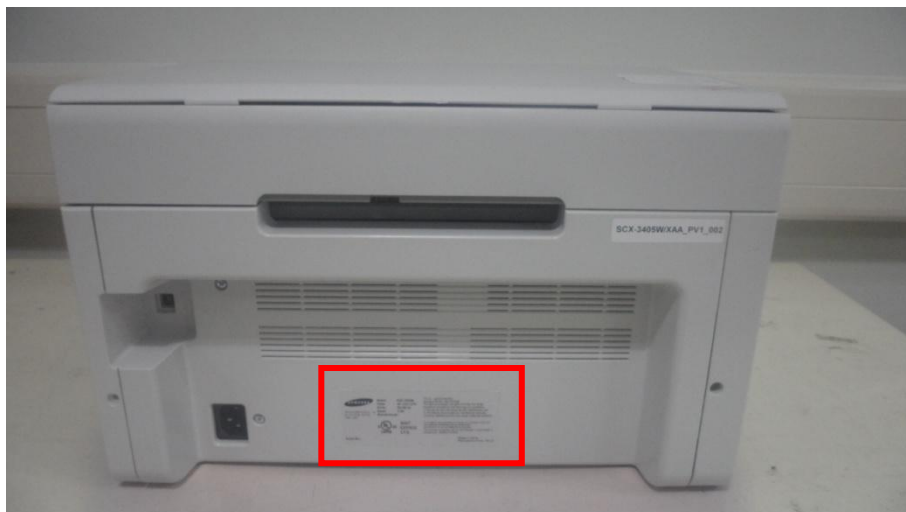



Rear View with label location



Side View (1)



Side View (2)

 Samsung Electronics Co., Ltd. Suwon, Korea, 443-742 Place: M264	Model: SCX-3405W Volts: AC 110-127V Hertz: 50/60 Hz Amps: 5.0A Manufactured:	FCC ID : A3LSCX3405W Contains FCC ID : MCLT77H262 This device complies with part 15 of the FCC Rules. Operation is subject to the following two conditions: i) This device may not cause harmful interference, and ii) This device must accept any interference received, including interference that may cause undesired operation.
	 3UU7 E337632 I.T.E.	This Class B digital apparatus complies with Canadian ICES-003 Cet appareil numérique de la classe B est Conforme à la norme NMB-003 du Canada. This product complies with 21 CFR Chapter 1, subchapter J. Contains IC : 2878D-T77H262
Serial No.:	Made in China Fabriqué en Chine REV.00	

Label