

SAMSUNG

SAMSUNG DIGIT*all*
everyone's invited™

User's Guide

Color All-in-One

SCX-1150F



Important Precautions and Safety Information

When using this product, these basic safety precautions should always be followed to reduce risk of fire, electric shock, and injury to persons:

- 1** Read and understand all instructions.
- 2** Use common sense whenever operating electrical appliances.
- 3** Follow all warnings and instructions marked on the product and in the literature accompanying the product.
- 4** If an operating instruction appears to conflict with safety information, heed the safety information. You may have misunderstood the operating instruction. If you cannot resolve the conflict, contact your sales or service representative for assistance.
- 5** Unplug the product from the AC wall socket and/or telephone jack before cleaning. Do not use liquid or aerosol cleaners. Use only a damp cloth for cleaning.
- 6** Do not place the product on an unstable cart, stand, or table. It may fall, causing serious damage.
- 7** Your product should never be placed on, near, or over a radiator, heater, air conditioner, or ventilation duct.
- 8** Do not allow anything to rest on the power. Do not locate your product where the cords will be abused by persons walking on them.
- 9** Do not overload wall outlets and extension cords. This can diminish performance, and may result in the risk of fire or electric shock.
- 10** Do not allow pets to chew on the AC power, telephone, or PC interface cords.
- 11** Never push objects of any kind into the product through case or cabinet openings. They may touch dangerous voltage points, creating a risk of fire or shock. Never spill liquid of any kind onto or into the product.

12 Your product may have a heavy cover for optimal pressure on the document for the best scanning and/or faxing (usually the flatbed-type product). In this case, replace the cover after placing document on the scan glass, hold the cover and move it down slowly until it seats on its location.

13 To reduce the risk of electric shock, do not disassemble the product. Take it to a qualified service technician when repair work is required. Opening or removing covers may expose you to dangerous voltages or other risks. Incorrect reassembly could cause electric shock when the unit is subsequently used.

14 Unplug the product from the telephone jack, PC and AC wall outlet, and refer servicing to qualified service personnel under the following conditions:

- When any part of the power cord, plug, or connecting cable is damaged or frayed.
- If liquid has been spilled into the product.
- If the product has been exposed to rain or water.
- If the product does not operate properly after instructions have been followed.
- If the product has been dropped, or the cabinet appears damaged.
- If the product exhibits a sudden and distinct change in performance.

15 Adjust only those controls covered by the operating instructions. Improper adjustment of other controls may result in damage, and may require extensive work by a qualified service technician to restore the product to normal operation.

16 Avoid using this product during a lightning storm. There may be a remote risk of electric shock from lightning. If possible, unplug the AC power and telephone cord for the duration of the lightning storm.

17 SAVE THESE INSTRUCTIONS.

CONTENTS

| | |
|--|---|
| Important Precautions and Safety Information | i |
|--|---|

Chapter 1: SET UP

| | |
|---|-------------|
| Setting Up Your Product | 1.2 |
| Contents | 1.2 |
| Control Locations and Functions | 1.3 |
| Front View | 1.3 |
| Rear View | 1.4 |
| Top View | 1.4 |
| Operation Panel Button Functions | 1.5 |
| Choosing a Location | 1.7 |
| Making Connections | 1.7 |
| Loading Paper | 1.11 |
| Installing Print Cartridges | 1.13 |
| Installing Software | 1.18 |
| About Samsung Software | 1.18 |
| System Requirements | 1.19 |
| Installing Samsung Software | 1.20 |
| Configuring Fax and Internet Gates | 1.24 |
| Uninstalling Samsung Software | 1.28 |
| Uninstalling the MFP Driver | 1.28 |
| Using the SmarThru CD-ROM | 1.32 |
| Basic System Setup | 1.33 |
| Setting Date and Time | 1.33 |
| Changing Date Format | 1.35 |
| Changing Clock Mode | 1.35 |
| Setting Fax Number and Name | 1.36 |
| How To Enter Characters Using the Number Keypad | 1.37 |
| Changing the Display Language | 1.39 |
| Setting the Discard Size | 1.40 |
| Setting Sounds | 1.41 |
| Ringer Volume, Alarm Sound, Key Sound | 1.41 |
| Speaker Volume | 1.41 |

| | |
|-----------------------------|------|
| Setting Dialling Mode | 1.42 |
| Using Save Mode | 1.43 |
| Ink Save | 1.43 |
| Paper Save | 1.43 |
| Power Save | 1.44 |

Chapter 2: PRINT

| | |
|--|------|
| Paper Selection | 2.2 |
| Guidelines for Special Media | 2.3 |
| Loading Speciality Paper | 2.4 |
| Paper Guidelines | 2.5 |
| Printing a Document | 2.6 |
| Printer Settings | 2.8 |
| Accessing Printer Settings | 2.8 |
| Printer Properties Tabs (Windows 95/98/Me) | 2.9 |
| Printer Properties Tabs (Windows NT 4.0) | 2.14 |
| Printer Properties Tabs (Windows 2000/XP) | 2.16 |
| Printer Properties Buttons & Icons | 2.17 |
| Using the Printer Control Program | 2.17 |
| Accessing the Printer Control Program | 2.17 |
| About Tab | 2.19 |

Chapter 3: COPY

| | |
|---|------|
| Setting Paper Size and Type | 3.2 |
| Paper Size | 3.2 |
| Paper Type | 3.3 |
| Loading the Original Documents | 3.3 |
| Using Automatic Document Feeder (ADF) | 3.4 |
| Using Document Glass | 3.5 |
| Copying a Document | 3.7 |
| Setting Copy Options | 3.8 |
| Quality | 3.8 |
| Contrast | 3.9 |
| Copy page | 3.9 |
| Zoom rate | 3.10 |
| Collating | 3.10 |
| Using Special Copy | 3.11 |
| Fit to Page | 3.12 |
| Clone | 3.12 |
| Poster | 3.13 |
| Mirror | 3.14 |

| | |
|---------------------------------|------|
| Changing Default Settings | 3.15 |
| Blocking Colour Copying | 3.16 |

Chapter 4: SCAN

| | |
|--|-----|
| Scanning Basics | 4.2 |
| Starting Scan from the Operation Panel | 4.2 |
| Scanning Process with TWAIN-enabled Software | 4.6 |

Chapter 5: FAX

| | |
|---|-------------|
| Sending a Fax | 5.2 |
| Preparing Documents for Faxing | 5.2 |
| Loading Document(s) | 5.3 |
| Adjusting Quality of Your Fax | 5.4 |
| Setting Resolution | 5.4 |
| Setting Contrast | 5.5 |
| Setting Default Resolution and Contrast | 5.6 |
| Sending a Fax Automatically | 5.7 |
| Confirming a Transmission | 5.8 |
| Automatic Redial | 5.8 |
| Sending a Fax Manually | 5.9 |
| Redial | 5.10 |
| Using Toll Save Transmission | 5.11 |
| Receiving a Fax | 5.13 |
| About Reception Modes | 5.13 |
| Loading Paper for Receiving Faxes | 5.14 |
| Receiving Automatically in FAX Mode | 5.15 |
| Receiving Automatically in ANS/FAX Mode | 5.15 |
| Receiving Manually in TEL Mode Using an Extension Phone . | 5.16 |
| Receiving Using DRPD Feature | 5.17 |
| Receiving in Colour | 5.17 |
| Receiving Fax in Memory | 5.17 |
| Using Fax Forwarding | 5.18 |
| Automatic Dialling | 5.20 |
| One-touch Dialling | 5.20 |
| Storing a Number for One-touch Dialling | 5.20 |
| Sending a Fax using a One-touch Number | 5.21 |
| Speed Dialling | 5.22 |
| Storing a Number for Speed Dialling | 5.22 |
| Sending a Fax using a Speed Number | 5.23 |

| | |
|--|-------------|
| Group Dialling | 5.24 |
| Setting Group Dial | 5.24 |
| Sending a Fax Using Group Dialling (Multi-Address Transmission) | 5.25 |
| Searching for a Number in the Memory | 5.26 |
| Searching Sequentially through the Memory | 5.26 |
| Searching with a Particular First Letter | 5.27 |
| Advanced Fax | 5.28 |
| Broadcasting | 5.28 |
| Delayed Fax | 5.30 |
| Priority Fax | 5.32 |
| Polling | 5.34 |
| Polling Transmission | 5.34 |
| Polling a Remote Machine | 5.36 |
| Adding Documents To a Scheduled Operation | 5.37 |
| Cancelling a Scheduled Operation | 5.38 |
| Additional Features | 5.39 |
| Printing Reports | 5.39 |
| Printing List | 5.41 |
| Fax Setup Options | 5.41 |
| Setting an Option | 5.41 |
| Selectable Options | 5.42 |
| Using the Fax Settings Utility | 5.47 |
| Accessing the Fax Settings Utility | 5.47 |

Chapter 6: MAINTENANCE

| | |
|--|------|
| Maintaining Print Cartridges | 6.2 |
| Viewing Ink Level | 6.3 |
| Cleaning Print Cartridges | 6.3 |
| Printing a Cleaning Page from the Product | 6.4 |
| Printing a Cleaning Page from Your Computer | 6.5 |
| Cleaning Print Cartridge Nozzles | 6.6 |
| Cleaning Cartridge Holder Contacts | 6.8 |
| Replacing Print Cartridges | 6.9 |
| Replacing Print Cartridges from the Product | 6.11 |
| Replacing Print Cartridges from the Computer | 6.13 |
| Aligning Print Cartridges | 6.15 |
| Aligning Print Cartridges from the Product | 6.15 |
| Aligning Print Cartridges from the Computer | 6.16 |
| Clearing Memory | 6.18 |
| Remote Test | 6.19 |
| Cleaning the Document Glass | 6.20 |

Chapter 7: TROUBLESHOOTING

| | |
|------------------------------------|------|
| Clearing Document Jams | 7.2 |
| Input Misfeed | 7.2 |
| Exit Misfeed | 7.3 |
| Roller Misfeed | 7.3 |
| Clearing Paper Jams | 7.4 |
| Tips for Avoiding Paper Jams | 7.6 |
| LCD Error Messages | 7.7 |
| Fixing Problems | 7.8 |
| Fax Problems | 7.8 |
| Paper Feeding Problems | 7.10 |
| General Printing Problems | 7.11 |
| Colour Printing Problems | 7.13 |
| Print Quality Problems | 7.14 |
| Scanning Problems | 7.16 |

Chapter 8: APPENDIX

| | |
|--|------|
| Printer Specification | 8.2 |
| Scanner and Copier Specification | 8.2 |
| Fax Specification | 8.3 |
| General Specification | 8.4 |
| Paper Specification | 8.5 |
| Replacing the Fitted Plug (UK) | 8.7 |
| Notes For Use of This Device (New Zealand) | 8.8 |
| Declaration of Conformity (European Countries) | 8.9 |
| Fax Branding (US) | 8.10 |
| Telephone Company Information (US) | 8.10 |

Index

NOTE



1

SET UP

Thank you for purchasing the Samsung SCX-1150F InkJet All in One. This multifunctional product provides printing, copying, scanning, and faxing functions!

This chapter provides step-by-step instructions on setting up the product, installing the software, and basic system setup. The chapter includes:

- **Setting Up Your Product**

- Contents
- Control Locations and Functions
- Operation Panel Button Functions
- Choosing a Location
- Making Connections
- Loading Paper
- Installing Print Cartridges

- **Installing Software**

- About Samsung Software
- System Requirements
- Installing Samsung Software
- Configuring Fax and Internet Gates
- Uninstalling Samsung Software





- **Basic System Setup**

- Setting Date and Time
- Setting Fax Number and Name
- Changing the Display Language
- Setting the Discard Size
- Setting Sounds
- Setting Dialling Mode
- Using Save Mode

Setting Up Your Product

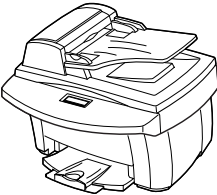
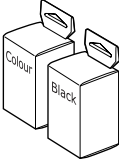
Contents

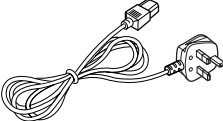
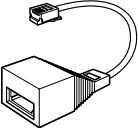
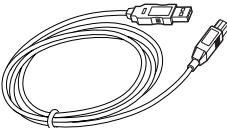
Below is what is included with your product.

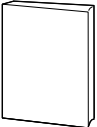
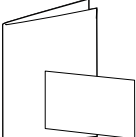
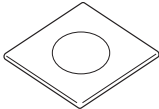
| | |
|---|---|
|  <p>SCX-1150F</p> |  <p>Colour and Black ink cartridges</p> |
|  <p>Telephone line cord*</p> |  <p>Power cord*</p> |
|  <p>TAM lead</p> |  <p>USB cable</p> |
|  <p>This User's Guide</p> |  <p>SmarThru User's Guide</p> |
|  <p>Quick Install Guide, Warranty Card</p> |  <p>Software CD</p> |

* The shape of the power and the telephone line cord plugs may differ, depending on your country.

Control Locations and Functions

Take a moment to familiarize yourself with the main components of your product.

Front View

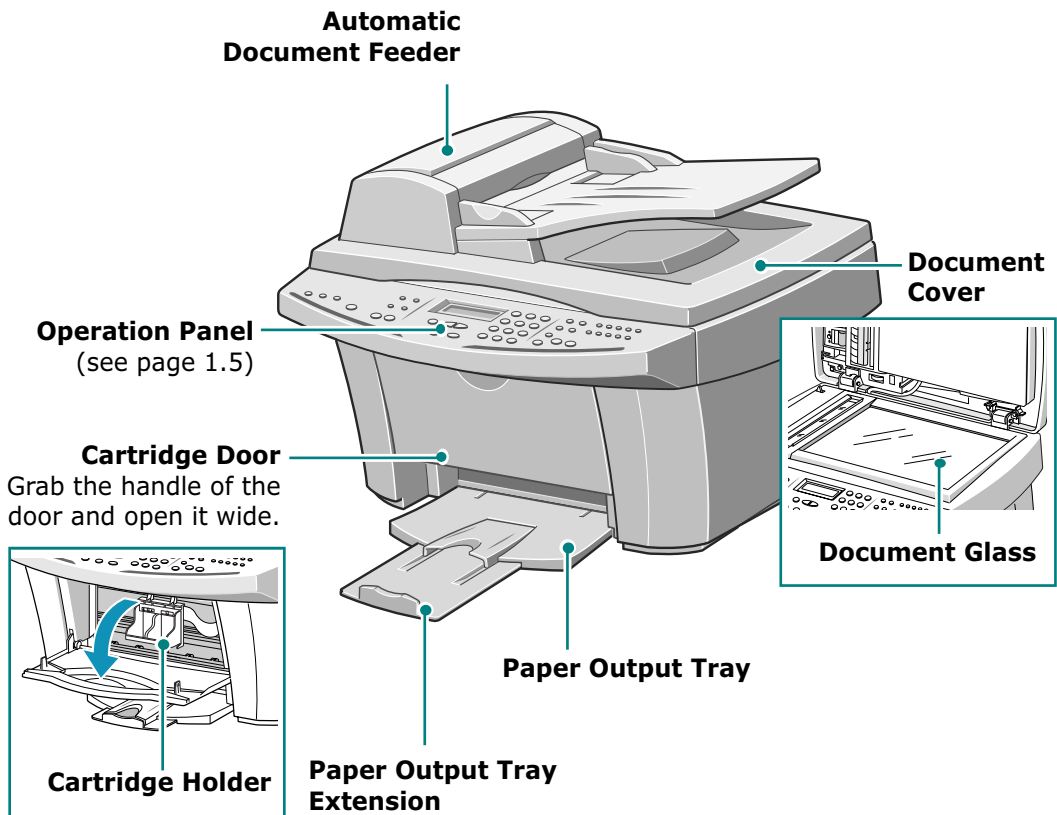

Rear View

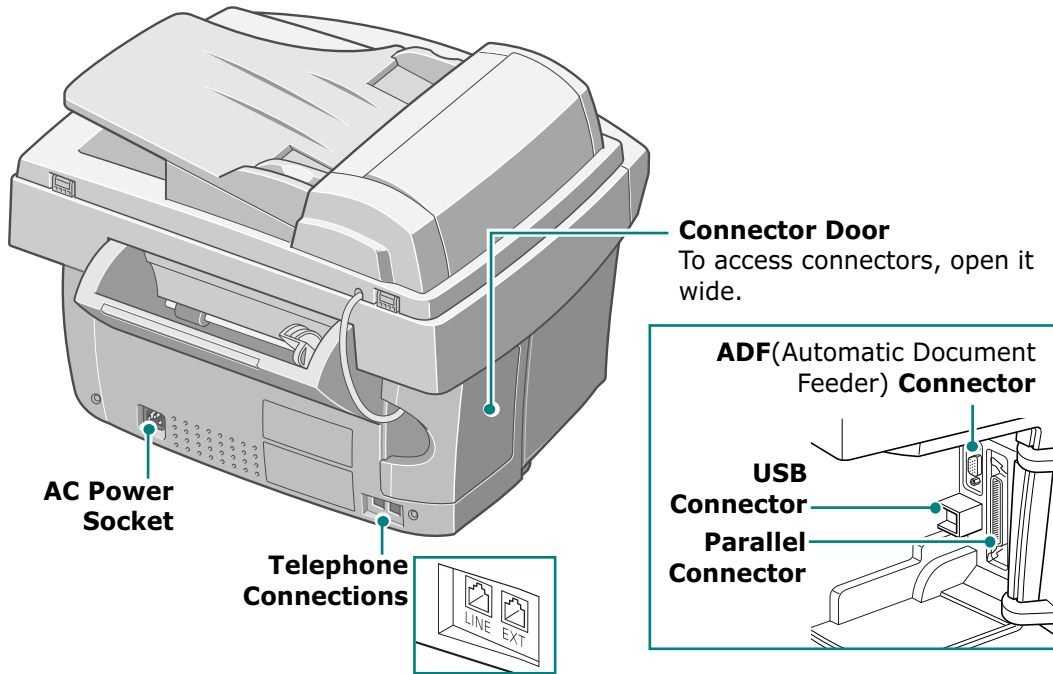



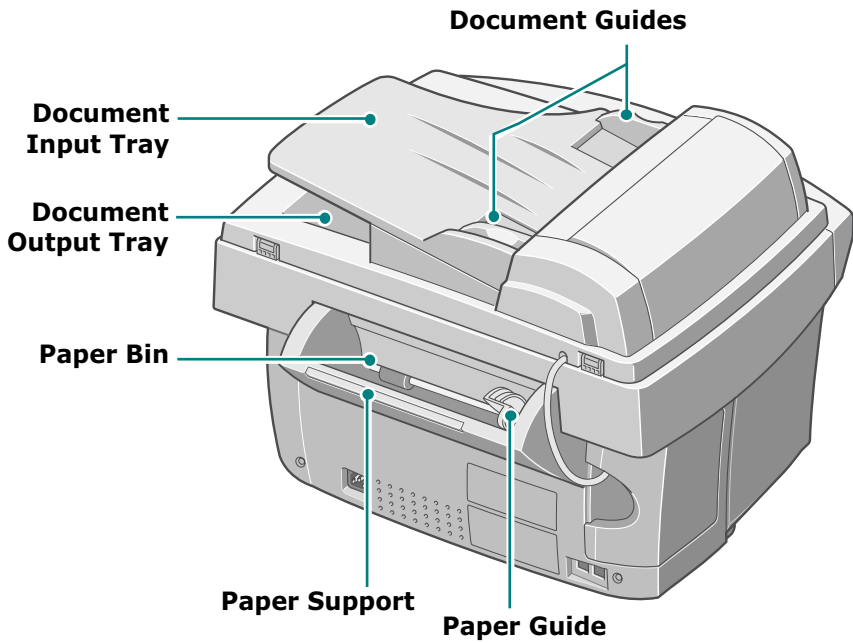



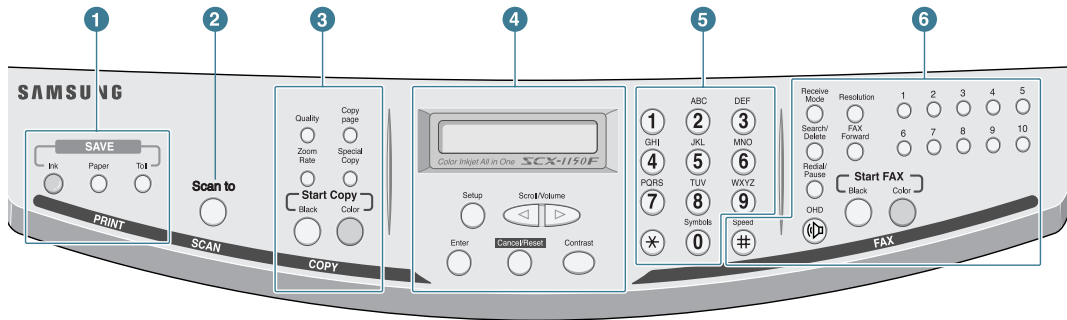



Top View



















Operation Panel Button Functions



 : Scan mode
 : Copy mode
 : Common
 : Fax mode

| | | |
|---|---|---|
| 1 |  | Allows you to save ink to a maximum of 50% by printing images lighter (available in PC print, Copy, and Fax receiving modes). |
| |  | Allows you to save paper by printing 2 pages on a single sheet of paper (available in Black&white Fax/Copy modes only). |
| |  | Allows you to save on call costs by sending a fax at a preset time. By using this feature, you can take advantage of lower long distance rates at night, for example (available in Fax sending only). |
| 2 |  | Launches Samsung Scan Wizard in the desktop window from which you can select the scan destination and adjust scan settings. |
| 3 |  | Adjusts the copy quality. |
| |  | Selects the number of copies. |
| |  | Makes a copy smaller or larger than the original. |
| |  | Allows you to set up special copy features including Fit to Page, Clone, Poster, and Mirror copy. |
| |  | Makes a black and white copy. |
| |  | Makes a colour copy. |

| | | |
|---|---|---|
| 4 |  | Displays current status and prompts during operation. |
| |  | Enters menu mode. |
| |  | Scrolls through the menu items. Also used to adjust the volume. |
| |  | Confirms the selection on the display. |
| |  | Cancels a current operation including PC printing or resets the copy and fax setting item (Quality, Copy Page, Zoom Rate, Resolution or Contrast) to its default setting. |
| 5 |  | Adjusts the contrast of the documents for the current fax or copy job. |
| |  | Use to dial a number or enter alphanumeric characters. |
| 6 |  | Use to choose the receive mode. The selected mode is displayed in Standby mode. |
| |  | Adjusts the resolution of the documents for the current fax job. |
| |  | Searches for numbers in memory. Also use to delete digits in the edit mode. |
| |  | Sets your product to forward incoming faxes to another fax number. |
| |  | Redials the last number or inserts a pause into a fax number. You can also view and dial any of the last numbers you dialed or received. |
| |  | Engages the telephone line. |
| |  | Starts to send a black and white fax. |
| |  | Starts to send a colour fax. |
| |  | Use to store frequently dialed fax numbers and dial them with a single press. |
| |  | Stores frequently dialed fax numbers and dial them using a 2-digit speed number. |

Choosing a Location

To achieve trouble-free operation of your product, place it on a flat, stable surface near your workstation. Leave enough space to allow for easy paper loading, paper out and opening the top cover.

Do not place your product:

- In direct sunlight.
- Near heat sources or air conditioners.
- In dusty or dirty environments.

Making Connections

- 1 Open the connector door.

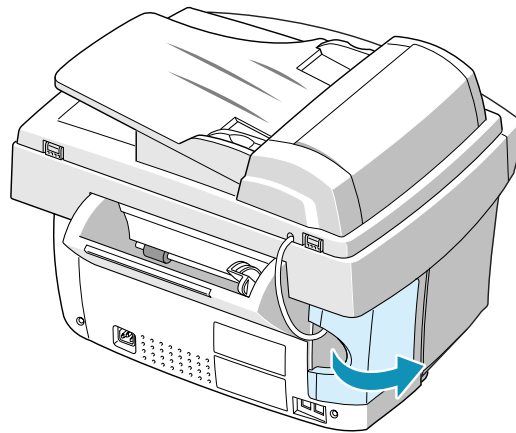

- 2** Connect the supplied telephone line to the **LINE** jack and the other end to the wall jack.

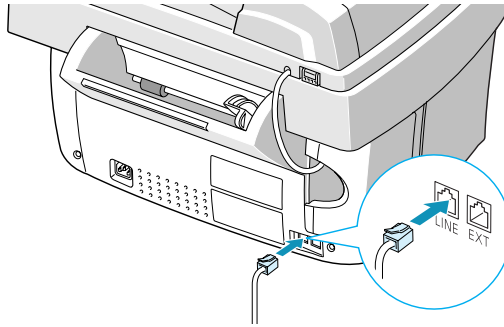

If you want to use your product for receiving both faxes and voice calls, you will need to connect a telephone and/or answering machine to your product.

Plug the cord of your extension phone or answering machine into the supplied TAM lead and plug the cord of the TAM lead into the **EXT** jack on the back of your product.

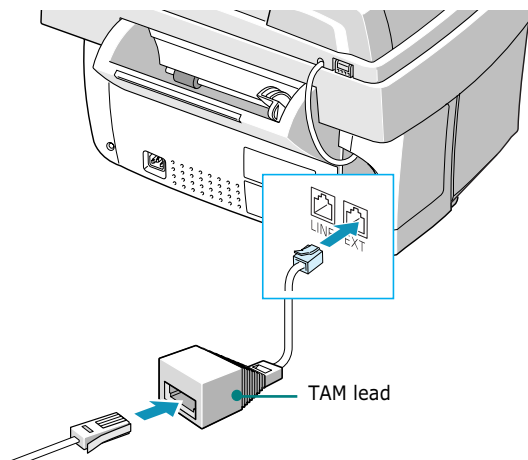

NOTES:

- This product is intended for connection to analogue telephone networks in the United Kingdom. It is strongly recommended to use the TAM lead and the telephone line cord supplied with your product.
- If you are replacing the line cord with other manufacturer's, it should be AWG #26 or lower gauge.

- 3** Connect the printer cable. Use either the USB cable that came with your product or an IEEE-1284 compliant parallel cable purchased separately.

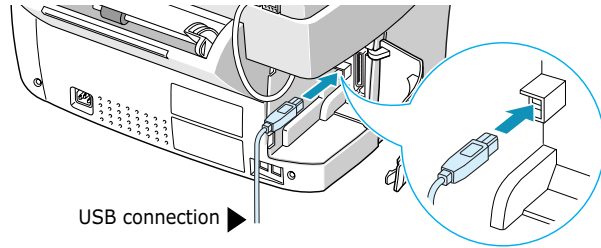

OR

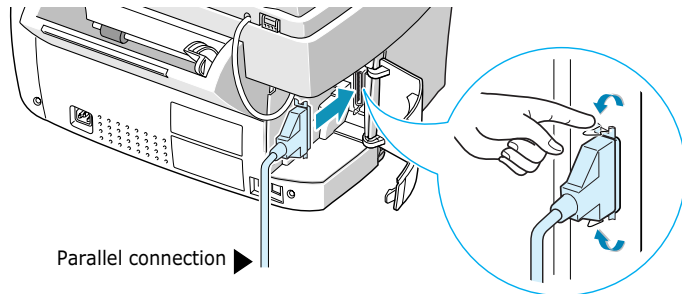

NOTES:

- You only need to connect one of the above cables. Shut down your computer before connecting the cable.
- When you are using a USB cable, you must be running Windows 98/Me/2000/XP.
- When using USB connection, your product provides two USB modes: Fast and Slow. Fast is the default mode. Some PC user may experience poor USB implementation in the default mode. If this occurs, select Slow mode to achieve successful results. For details on changing the USB mode, see page 7.12.

- 4** Close the connector door.

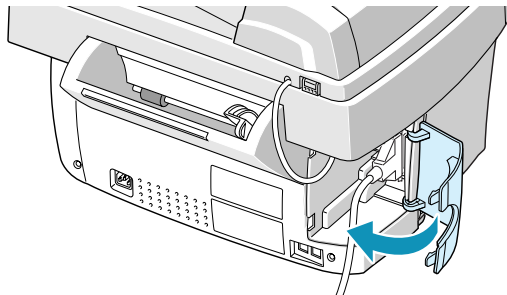

5 Connect the power cord.

Plug one end of the supplied three-wire electrical grounding type cord into the back of the product and the other end into a properly grounded AC outlet.

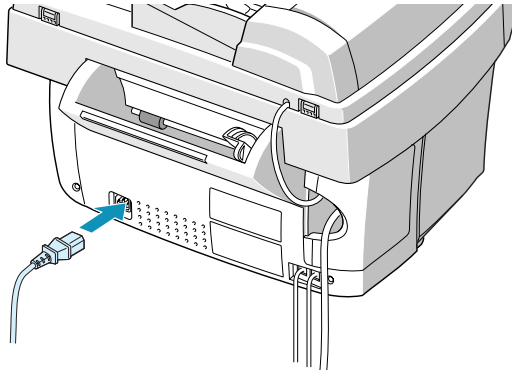

As you plug it in, your product will turn on. "POWERING UP PLEASE WAIT" appears on the display indicating the product is on. To view your display text in another language, see page 1.39.

If you want to turn your product off, unplug the power cord.



NOTES: When you first set up the product, you see "CHECK CARTRIDGES" on the display. Load the paper (see page 1.11), then install the print cartridges (see page 1.13).

Loading Paper

The display will show "ADD PAPER THEN PRESS ENTER" if no paper is loaded when starting to print a job. The paper bin can hold approximately 100 sheets of 20lb plain paper.

In the Fax or Copy mode, you can use A4-, letter-, or legal-size paper.

To load plain paper:

- 1 Pull the paper support on the paper bin all the way up.

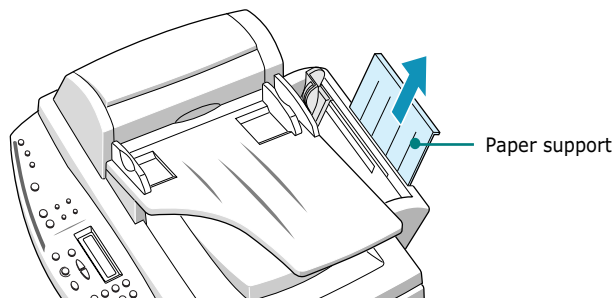

- 2 Fan the paper and then insert it with the print side facing you. Ensure that the right edge of the paper is in contact with the right side of the paper bin. Do not exceed the specified capacity.

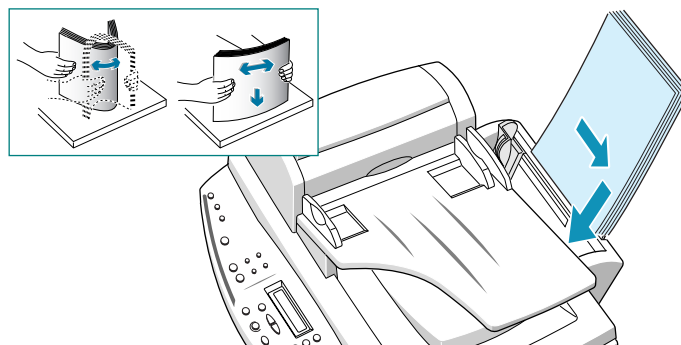

NOTES:

- Do not force the paper down into the printer.
 - It is recommended to load a stack of paper (more than 20 sheets) to ensure proper paper feeding.
-

- 3 Squeeze the left paper guide and move it to the right to match the width of the paper.

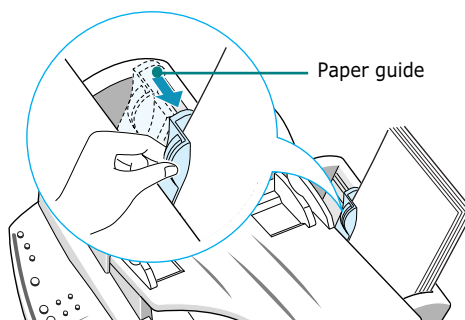

- 4 Pull the output tray and the output tray extender on the front of the product all the way out.

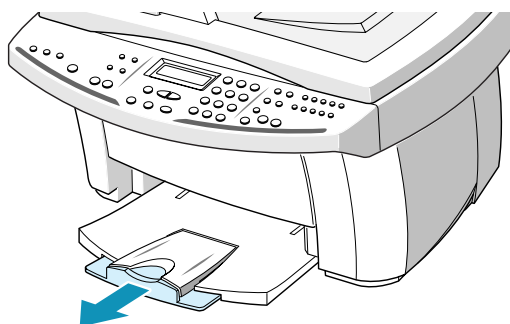

NOTES:

- Your product emits warning tones when the paper bin is empty due to one of the following reasons:
 - The paper does not load when starting to print a job.
 - It runs out of paper while printing.

The LCD display shows "ADD PAPER THEN PRESS ENTER." To start or continue the print job, install paper into the paper bin then press the **Enter** button.

- If you are using legal-size paper, do not pull the output tray out. Push it in, or it may cause a paper jam when the paper prints out.

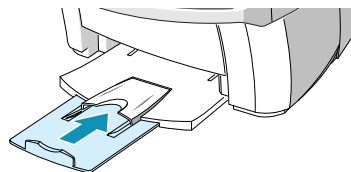

- After you load paper, you have to set up your product for the paper size you have used. See page 3.2 for copying, 5.42 for faxing, or 2.10 for PC printing.

Installing Print Cartridges

Your product comes with a black and a colour cartridge. You can purchase an optional photo cartridge and install it instead of the black cartridge. See page 1.17 for the options you can purchase.

When the product is turned on without the print cartridges installed, the display shows "CHECK CARTRIDGES."

Use this procedure when installing print cartridges for the first time. To install replacement print cartridges, refer to "Replacing Print Cartridges" on page 6.9.



NOTE: There are two types of black and colour cartridge: Standard and High yield. Before proceeding to install, you need to check which cartridge type you have. When you install the cartridges, you will be asked if it is Standard or High Yield. To find out the type, please refer to the table on the page 6.9.

- 1** Unwrap and remove the colour print cartridge from its plastic bag. Hold the print cartridge at the top only. Do not touch the electrical contacts.

Carefully remove the sealing tape covering the print head.

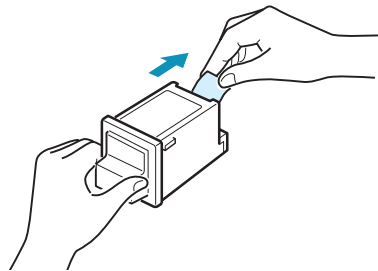

- 2** Grab the handle on the cartridge door and open the door.

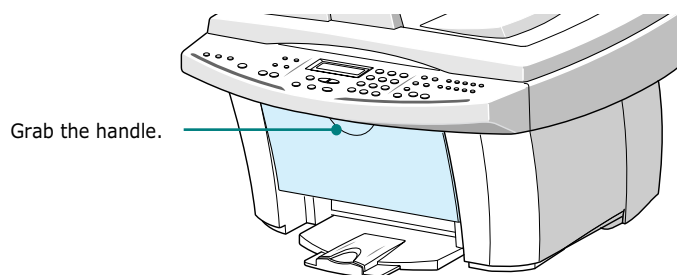

3 The cartridge holder moves to the install position.

The colour cartridge is inserted into the left side of the cartridge holder and can be identified by a yellow tab on the top of the holder.

The black (or photo) cartridge is inserted into the right side of the cartridge holder and can be identified by a green tab on the top of the holder.

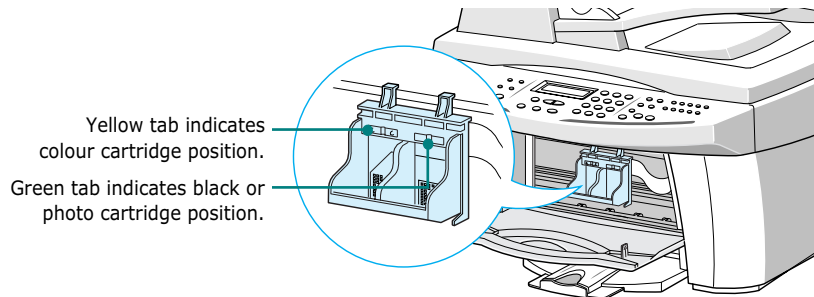

4 Place the colour print cartridge into the left side of the holder.

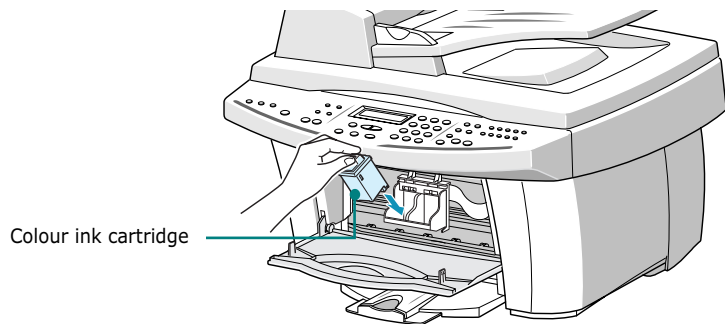

5 Push the colour cartridge back until it clicks into place.

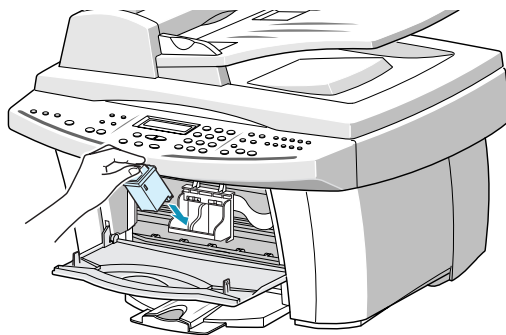

- 6 Unwrap and remove the black print cartridge from its plastic bag. Holding the cartridge at the top, carefully remove the sealing tape covering the print head.

Place the black print cartridge into the right side of the holder.

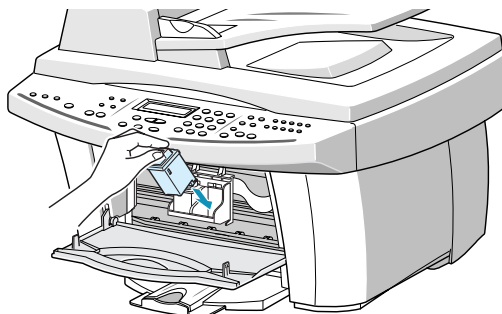

- 7 Push the black print cartridge back until it clicks into place.

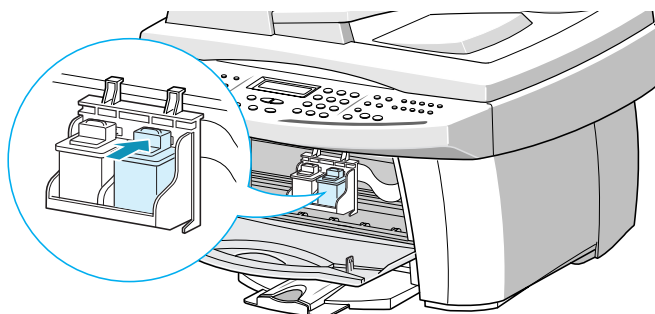

- 8 After installing the print cartridges, close the cartridge door.

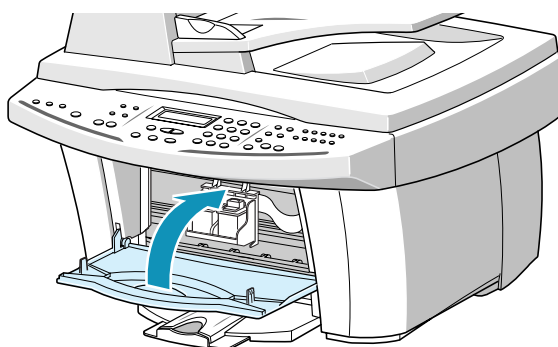

NOTE: If the display shows "REMOVE PAPER JAM AND PRESS CANCEL" when you have closed the cartridge door, re-install the cartridge(s). With the print cartridge(s) installed improperly, the product might not print.

- 9 When you close the door, the display shows "CARTRIDGE CHANGED? NO." Press the **Scroll** buttons (◀ or ▶) until you see "BOTH" at the bottom right corner of the display and then press **Enter**.
- 10 The display shows "LEFT CARTRIDGE NEW COLOR". Press **Enter** to confirm you have installed a new colour cartridge.
- 11 The display shows "LEFT CARTRIDGE STANDARD COLOR". If you have installed a standard capacity colour cartridge, press **Enter**. If not, press the **Scroll** buttons (◀ or ▶) to display "LEFT CARTRIDGE HIGH YIELD COLOR" and then press **Enter**.
- 12 The display shows "RIGHT CARTRIDGE NEW BLACK". Press **Enter** to confirm you have installed a new black cartridge.
- 13 The display shows "RIGHT CARTRIDGE STANDARD BLACK". If you have installed a standard capacity black cartridge, press **Enter**. If not, press the **Scroll** buttons (◀ or ▶) to display "RIGHT CARTRIDGE HIGH YIELD BLACK" and then press **Enter**.
- 14 The cartridge holder returns to the home position. The Cartridge Alignment procedure begins automatically by printing a Cartridge Alignment form.

Use this form to identify the straightest line in each of six alignment areas. By selecting the straightest line for each pattern, you will optimise the print head alignment.

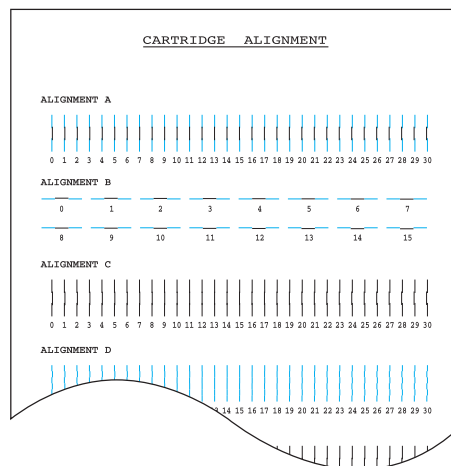

- 15** Looking at the Cartridge Alignment form, identify the straightest line in Alignment A. Using the number keypad, enter the two digit number of the straightest line and then press **Enter**.
- 16** The display accepts the number and moves to Alignment B. Repeat step 15 for Alignment patterns B-F.

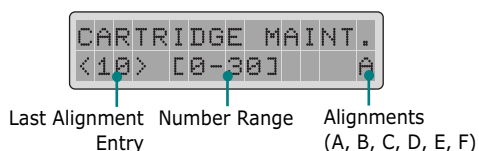

- 17** When you finish entering the number for Alignment F, the display returns to Standby mode.

Then the display prompts you to set the current date and time. See page 1.33 to set the date and time.



NOTES:

- Keep a spare print cartridge on hand. When buying print cartridges, check the part numbers referenced below to ensure buying the correct print cartridge. These print cartridges have been specifically designed to work with your product to produce results that are always clear and sharp.
- If you want to purchase a new print cartridge, either contact your point of purchase or any Lexmark authorised supplies dealer.

| Cartridge type | | Part number |
|------------------|------------|------------------------------------|
| Black cartridge | High yield | Lexmark 12A1975 |
| | Standard | Samsung INK-M50 Lexmark 12A1970 |
| Colour cartridge | High yield | Lexmark 15M0125 |
| | Standard | Samsung INK-C60 Lexmark 15M0120 |
| Photo cartridge | | Lexmark 12A1990 |

Installing Software

About Samsung Software

You must install the SmarThru CD-ROM after you have setup your product and connected it to your computer. The SmarThru CD-ROM includes the following:

- MFP Driver
- SmarThru Software
- OCR Software (AnyPage Lite)

MFP Driver

To use your product as a printer and scanner, you must install the MFP driver.

SmarThru Software

SmarThru is the accompanying software for your SCX-1150F multifunctional product. SmarThru contains a powerful image editor that allows you to edit images in many ways and also includes a powerful Internet mail client software. With SmarThru, you can save the scanned images in a dedicated storage area for subsequent editing, sending via e-mail or fax, printing, and processing by other programs of your choice.

OCR Software (AnyPage Lite)

OCR (Optical Character Recognition) is software that has the ability to recognise most character formats, so that a scanned document can be read and edited with word processing software.

System Requirements

Before you begin, ensure your system meets the minimum requirements.

Supported Operating System

Windows 95 OSR2/Windows 98/Windows Me/Windows NT 4.0 Workstation or Server with Service Pack 3/Windows 2000 Professional or Server/Advanced Server/Windows XP Home edition or Professional.

Minimal Requirements

- Disk space: 130 MB for installation
- Memory: 64 MB
- CPU: Pentium II 233
- Required software: Internet Explorer 4.01

Recommended

- Disk space: 250MB for installation database
- Memory: 128MB
- CPU: Pentium II 400 or higher
- Required software: Internet Explorer 5.5 or above



NOTES:

- Administrative rights should be set for installation on Windows NT4.0/2000/XP.
 - Windows 95 versions prior to OSR2 are not recommended due to compatibility with OLE/COM libraries.
-

Installing Samsung Software



NOTES:

- For Windows 95/98/Me/2000/XP users, cancel the “New Hardware Found” screen when the computer boots up.
 - Make sure that your SCX-1150F is plugged in and connected to your computer’s parallel port or USB port **before installing the software from the CD**. Windows 95 and Windows NT 4.0 do not support USB connection.
-

- 1** Insert the supplied SmarThru CD-ROM into your CD-ROM drive.

The SmarThru CD-ROM should automatically run and the opening window appears.

If the opening window does not appear, click **Start**, and then **Run**. Type **X:Autorun.exe**, replacing “X” with the letter of your drive, and click **OK**.

If you are asked to select the language, choose the desired language.

- 2** Click **Install the Samsung Software on your PC**.

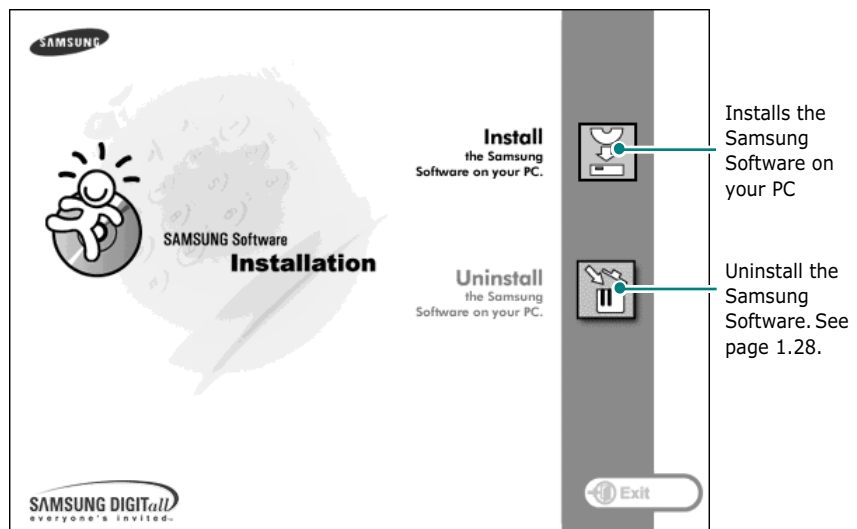

- 3** Follow the on-screen instructions and click **Next**.

- 4 The SmarThru installation supports three types of setup:
- **Typical:** Program will be installed with the most common options and is recommended for most users.
 - **Compact:** Only the MFP driver will be installed.
 - **Custom:** You may choose the options you want to install. Recommended for advanced users.

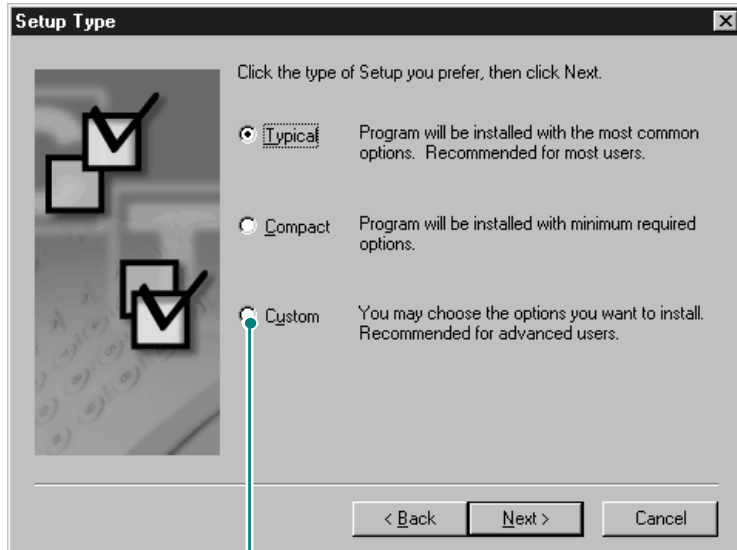

If you select the Custom installation, you may choose the options you want to install.

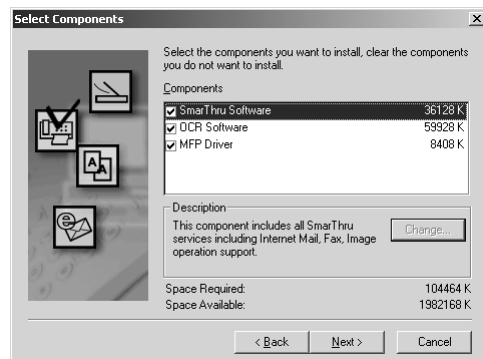

- **SmarThru Software:** to scan and edit images and work with electronic documents.
- **OCR Software:** AnyPage Lite software to enable OCR.
- **MFP Driver:** to print and scan.

- 5 Click **Next**.

- 6** You can choose SmarThru networking option. This feature allows you to share the modems on your computer and the scan device SCX-1150F via a network or to access these shared devices located on other computers.

Stand-alone configuration does not allow you to use any networking features such as Remote Fax or Remote Scan service.

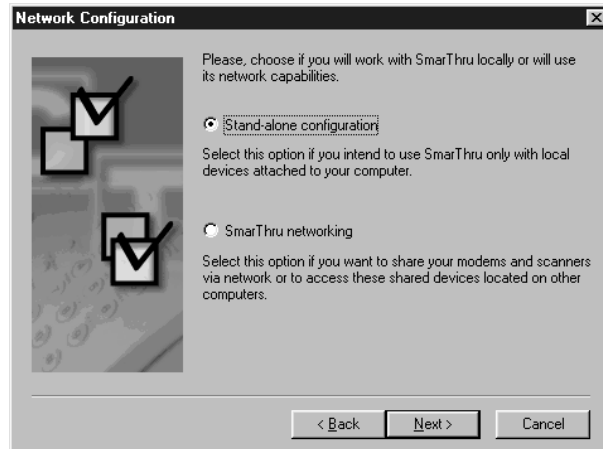

If you selected **SmarThru networking**, you can select to install server, client, or both.

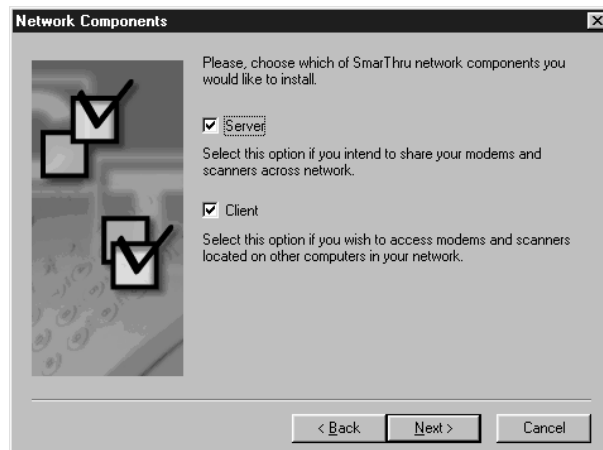

Server allows you to share local fax modem and/or scanner over a LAN. You can control sharing by managing remote service user. **Client** allows you to use Remote Fax or Remote Scan services provided by SmarThru Remote Services Server over a LAN. You need to have a client account. These accounts are provided by the server. For details on Remote Fax/Scan Services, please refer to the SmarThru User's Guide.

7 Click **Next**.

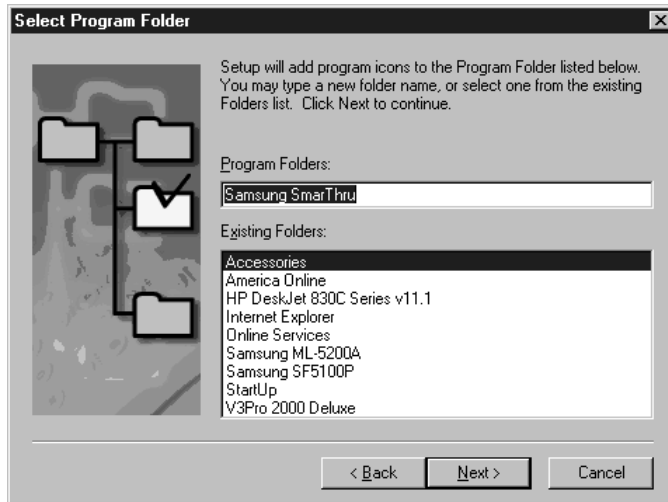

8 When the installation is completed, shut down and restart your computer.

If your computer does not shut down and restart automatically, you must shut it down manually and restart it before the changes will be saved.



NOTE: When you install the software, the Digital Signature Not Found window appears in Windows 2000 and Windows XP. Click **OK** in Windows 2000 and click **Continue Anyway** in Windows XP.

Configuring Fax and Internet Gates

If you select **SmarThru networking Server** option (see page 1.22), when your computer restarts after the Samsung software has installed, you will be prompted to configure the fax and Internet gates allowing you to send and receive faxes and e-mails on the SmarThru system.

If you select the **Stand-alone** or **SmarThru networking Client** option (see page 1.22), the following wizards appear only the first time you try to launch the Mailbox in the SmarThru program. For information on SmarThru, please refer to the SmarThru User's Guide.)



NOTE: To configure the Internet gate, you must enter your e-mail address, incoming (POP3 or IMAP4) and outgoing (SMTP) mail server address, and account name. Ask your Internet service provider or on-line service provider for the information on your Internet gate configuration.

- 1 When the New Modem Wizard appears, choose the system modem installed in your system and then click **Next**. This fax modem will be used by SmarThru Fax Gate for sending and/or receiving faxes.

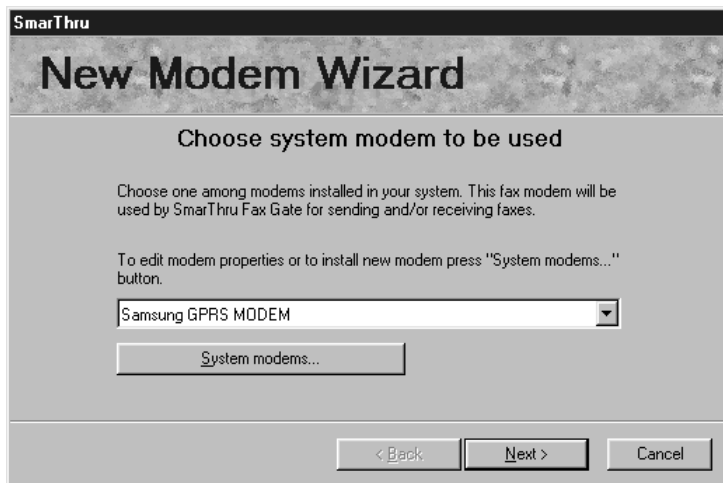

- 2 Click **Finish** to save the modem setting.

- 3 Enter your name and e-mail address, then click **Next**. The e-mail address will have been assigned to you by your Internet service provider.

The screenshot shows the 'New Mail Account Wizard' window with the title 'Internet E-Mail Address'. It contains two input fields: 'Enter your name:' with the text 'burir1Me' and 'Enter your e-mail address:'. Below the name field is an example: 'For example: John A. Smith'. Below the email field is an example: 'For example: mailbox@company.com'. A note at the bottom states: 'Note: Your e-mail address is the address other people use to send e-mail messages to you. This address has been assigned to you by your Internet service provider.' At the bottom right are three buttons: '< Back', 'Next >', and 'Cancel'.

- 4 Enter the addresses of your incoming and outgoing mail servers. Choose the incoming mail server type, then click **Next**. Your Internet service provider will be able to provide you with this information.

The screenshot shows the 'New Mail Account Wizard' window with the title 'E-Mail Server Addresses'. It contains two input fields: 'Incoming (POP3 or IMAP4) mail server address:' and 'Outgoing (SMTP) mail server address:'. Below the incoming field is an example: 'For example: company.com'. Below the outgoing field is an example: 'For example: company.com'. To the right of the outgoing field is a dropdown menu labeled 'Incoming mail server protocol type:' with 'POP3' selected. At the bottom right are three buttons: '< Back', 'Next >', and 'Cancel'.

- 5 Enter your account name and password to access your Internet mail server, then click **Next**. Your Internet service provider will be able to provide you with this information.

The screenshot shows a window titled "SmarThru" with a header "New Mail Account Wizard". The main heading is "Incoming mail server". Below this, there is a paragraph: "Please type your POP3 or IMAP4 account user name and password to access your Internet mail server. Your Internet service provider must give you this information." There are two input fields: "Account user name:" with the text "bruce999" and "Password:" with "*****". A note below the password field says "(Your password will appear in asterisks to prevent others from reading it.)". At the bottom, there are three buttons: "< Back", "Next >", and "Cancel".

- 6 Enter an account record name, then click **Next**.

The screenshot shows a window titled "SmarThru" with a header "New Mail Account Wizard". The main heading is "Account record name". Below this, there is a paragraph: "Please type account record name. This name will be used to refer it in Internet Gate Configuration and any incoming mail information notifications." There is one input field labeled "Account name:" with the text "chollian". At the bottom, there are three buttons: "< Back", "Next >", and "Cancel".

- 7 Click **Finish** to quit the wizard and enable Internet e-mail service.



NOTE: If you wish, you can reconfigure the Internet gate later by using SmarThru Configuration. For details, refer to the SmarThru User's Guide.

Uninstalling Samsung Software

Uninstall is required if you are upgrading the software or if your installation fails. You can uninstall all software including SmarThru and MFP drivers using the SmarThru CD or selectively uninstall the desired item using the Window unInstallShield.



NOTE: Before beginning un-installation, ensure all applications are closed on your PC. A system reboot is required after the software is uninstalled.

Uninstalling the MFP Driver

- 1 From the **Start** menu, select **Programs**, then select **Samsung SCX-1150 Series**.

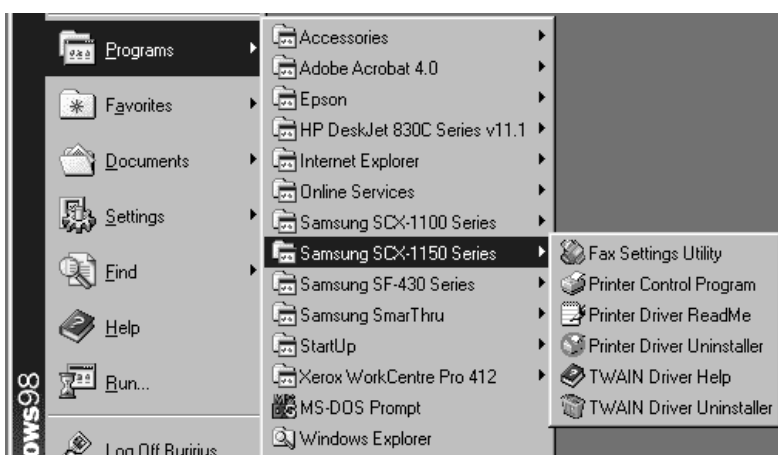

▲ In the case of Windows 98

- 2 You can select the component in the MFP driver to uninstall individually.

If you want to uninstall the scan driver, select **TWAIN Driver Uninstaller**.

If you want to uninstall the printer driver, select **Printer Driver Uninstaller**. Restarting your computer will be required.

- 3 When your computer confirms your selection, click **Yes**. The selected printer driver and all its components are removed from your computer.

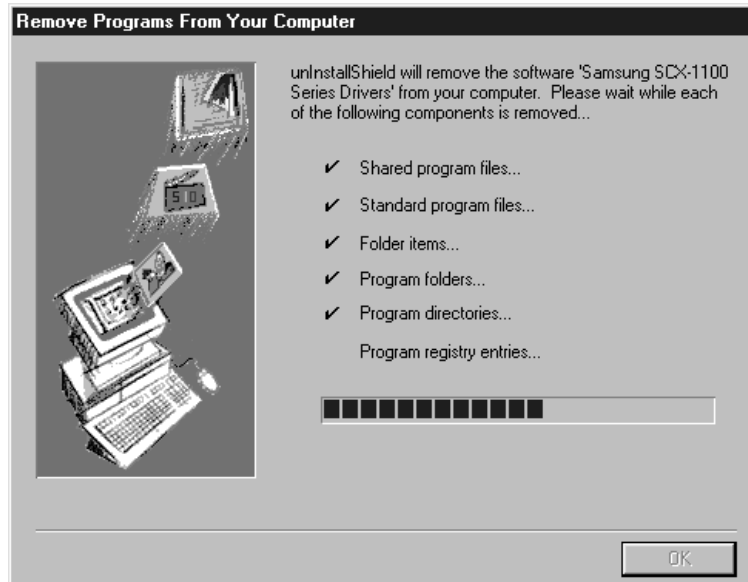

- 4 When the uninstallation is done, click **OK**.
- 5 The message box recommends you restart your computer. Click **OK**, then restart Windows.



NOTE: If you want to install the printer driver or the scan driver using the SmarThru CD-ROM, make sure that you select the Setup Type to **Compact**. Or select **Custom** then select **MFP Driver**. For details, see page 1.21

Uninstalling Samsung SmarThru

- 1 From the **Start** menu, select **Programs**.
- 2 Select **Samsung SmarThru**, then select **SmarThru 3 Uninstall**.

- 3** When your computer asks you to confirm your selection, click **Yes**. The Uninstall Options dialog box appears.

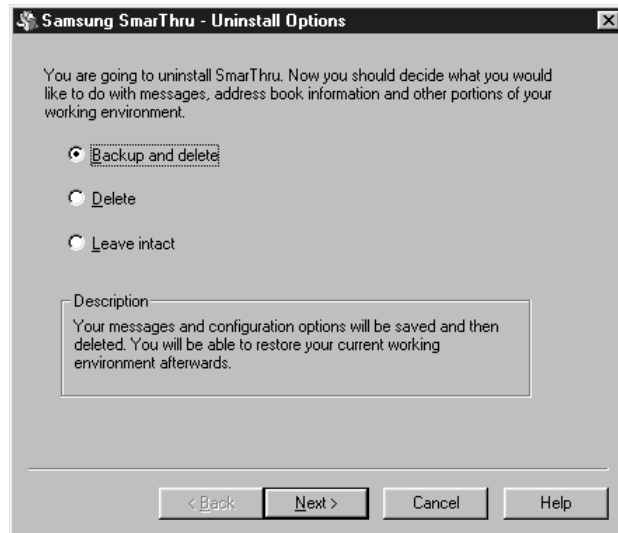

Uninstall options are:

- **Backup and delete:** Backs up all your data and options to a safe place. Then removes SmarThru system including the data.
 - **Delete:** Deletes all the SmarThru data and options. No backup or copying takes place. Be careful while using this option as you can easily lose your data.
 - **Leave intact:** Uninstalls SmarThru software leaving data and option intact. This can be useful, if, for example, you decide to install Stand Alone configuration over SmarThru Networking. In this case, uninstall Samsung SmarThru having **Leave intact** option set and install SmarThru Stand Alone configuration.
- 4** After selecting the uninstall option, click **Next**.

- 5 Follow the on-screen instructions to complete the uninstallation. The SmarThru software and all components will be removed.

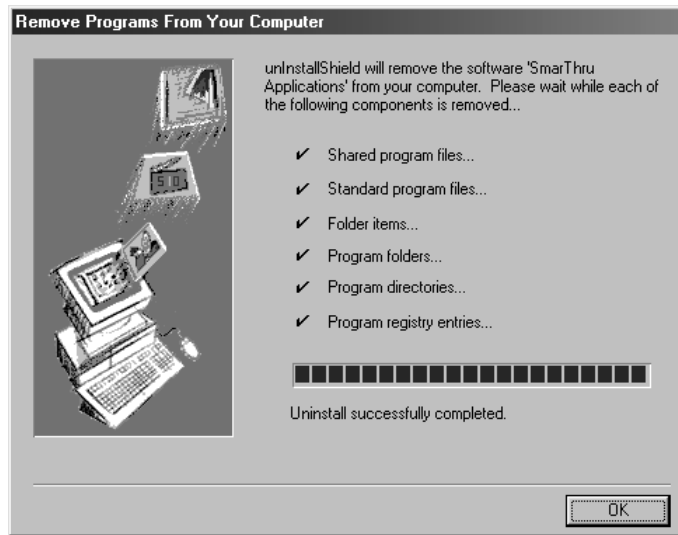

- 6 When uninstalling is done, click **OK**. The message box recommends restarting your computer.
- 7 Click **OK**.

Shut down and restart your computer to complete the uninstallation process and save your changes.

Using the SmarThru CD-ROM

You can uninstall both the MFP driver and the SmarThru software with the CD-ROM you have used to install the software.

- 1 Insert the SmarThru CD-ROM into your CD-ROM drive.

The SmarThru CD-ROM should automatically run and the opening window appears. (If the opening window does not appear, select **Run** from the **Start** menu, then type **X:Autorun.exe**, replacing "X" with the letter of your drive and click **OK**.

If you are asked to select the language, choose the desired language.

- 2 Click **Uninstall the Samsung software on your PC**.

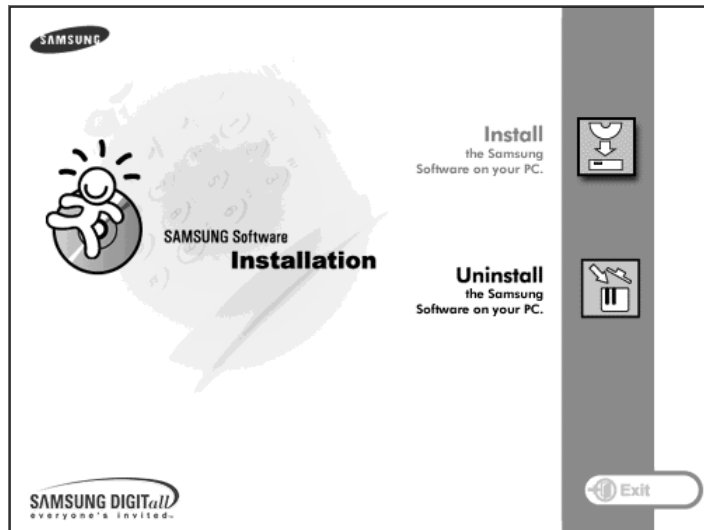

- 3 Follow the on-screen instructions to complete uninstallation.

You must shut down and restart your computer before any changes you have made will take affect.

Basic System Setup

1

Setting Date and Time

If you are setting up the product for the first time, or if the product has been unplugged for an extended period of time, the LCD display prompts you to set the current date and time.

The current date and time are shown on the display when the product is in Standby mode. The time and date are also printed on all faxes you send.

In Standby mode, you can also access the date and time setup menu any time by taking the following steps:

- 1** Press **Setup**. The display shows "1.SYSTEM SETUP" on the bottom line.
- 2** Press **Enter**. The display shows "FAX NUMBER/NAME" on the bottom line.
- 3** Press the **Scroll** buttons (◀ or ▶) until you see "DATE/TIME" and then press **Enter**. The date currently set for the product are displayed.

Take the following steps to enter your current date and time:

- 1 A flashing cursor prompts you to enter the date. Use the number keypad to enter the current date. You can use the **Scroll** buttons (◀ or ▶) to manually move the cursor to a digit you wish to change.



The default is the Europe format D-M-Y (Day-Month-Year). You can change the date format to the USA format M-D-Y (Month-Day-Year). See page 1.35.

- 2 Press **Enter** when the date on the display is correct.

If you enter an invalid number, the product beeps and does not proceed to the next step. If this happens, just re-enter the correct number.

- 3 The display asks you to enter the time. Use the number keypad to enter the current time using a 24-hour format (e.g. 1:00 PM as 13:00).

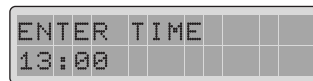

You can change the clock mode to 12-hour format. Use the **Scroll** buttons to select AM or PM. See page 1.35.

- 4 Press **Enter** when the time on the display is correct. The display automatically returns to Standby mode.

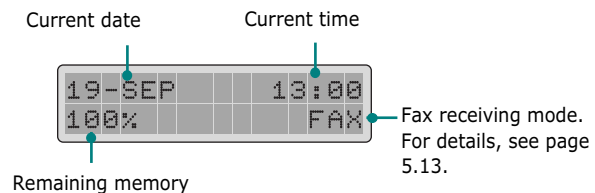

Changing Date Format

Your product displays the current date in Europe format. Europe format displays the date in the order of Day-Month-Year. You can change the date format in USA format (Month-Day-Year).

Take the following steps to change the date format:

- 1** Press **Setup**. The display shows "1.SYSTEM SETUP" on the bottom line.
- 2** Press **Enter**.
- 3** Press the **Scroll** buttons (◀ or ▶) until you see "DATE FORMAT" and then press **Enter**. The date format currently set for the product is displayed.
- 4** Press the **Scroll** buttons (◀ or ▶) to select the other format and then press **Enter** to save the selection.

Changing Clock Mode

You can configure the product to display time using either a 12-hour or 24-hour format.

Take the following steps to change the clock mode:

- 1** Press **Setup**. The display shows "1.SYSTEM SETUP" on the bottom line.
- 2** Press **Enter**.
- 3** Press the **Scroll** buttons (◀ or ▶) until you see "CLOCK MODE" and then press **Enter**. The clock mode currently set for the product is displayed.
- 4** Press the **Scroll** buttons (◀ or ▶) to select the other mode and then press **Enter** to save the selection.

Setting Fax Number and Name

In some countries you are required by law to indicate your fax number on any fax you send. The fax number and name will be printed at the top of each page sent from your product.



NOTE: Depending on your country, the Fax Number/Name setting may be unavailable.

- 1** Press **Setup** on the operation panel. The display shows "1.SYSTEM SETUP" on the bottom line.
- 2** Press **Enter** to access the System Setup menu.
- 3** The display shows the first option "FAX NUMBER/NAME" on the bottom line. Press **Enter** to access the Fax Number/Name menu.

The displays asks you to enter the fax number. If there is a number already set, the number appears.

- 4** Enter your fax telephone number. You can include **+** symbol in the phone number by pressing the ***** button and insert a **-** symbol by pressing **#** button.

If you make a mistake, move the cursor under the wrong digit by pressing the **Scroll** buttons (**◀** or **▶**). Press the correct number to change. To delete a number, press **Search/Delete**.

- 5** Press **Enter** when the number on the display is correct. The display asks you to enter the name.
- 6** Enter your name or company name by using the number keypad.

For details on how to use the number keypad to enter alphanumeric characters, see 1.37.

- 7** Press **Enter** when the name on the display is correct. The display automatically returns to Standby mode.

How To Enter Characters Using the Number Keypad

As you perform various tasks, you'll need to enter a name. For example, when you set up your product, you enter your name (or your company's name). When you store numbers in memory, you may also enter the corresponding names.

To enter alphanumeric characters:

- 1 When prompted to enter a name, locate the button labeled with the character you want.



Press the button repeatedly until the correct letter appears in the display.

For example, to enter the letter **O**, press **6**, (labeled MNO).

Each time you press **6**, the display shows a different letter, first **M**, then **N** and **O**, and finally **6**.



You can enter special characters (space, plus sign, etc.). For details, see "Keypad Character Assignment" on page 1.38.

- 2 To enter additional letters, repeat Step 1.

If the next letter is printed on the same button, move the cursor by pressing the **Scroll** button (▶), then press the button labeled with the letter you want.

The cursor moves right and the next letter appears in the display.

If you want to insert a space in the name, you can also use the **Scroll** button (▶) to move the cursor and skip the position.

- 3 When you finish entering letters, press **Enter**.

Keypad Character Assignment

| Key | Assigned numbers, letters or characters |
|----------|---|
| 1 | Space 1 |
| 2 | A B C 2 |
| 3 | D E F 3 |
| 4 | G H I 4 |
| 5 | J K L 5 |
| 6 | M N O 6 |
| 7 | P Q R S 7 |
| 8 | T U V 8 |
| 9 | W X Y Z 9 |
| 0 | + - , . ' / * # & 0 |

Editing Numbers or Names

If you make a mistake, move the cursor under the wrong character by pressing the **Scroll** buttons (◀ or ▶) and enter the correct number to change. To delete a letter, press **Search/Delete**.

Inserting a Pause while Entering a Number

With some telephone systems, you must dial an access code (9 for example) and listen for a second dial tone. In such cases, you must insert a pause in the telephone number. You can insert a pause while you are setting up speed dial numbers.

To insert a pause, press **Redial/Pause** at the appropriate place while entering the telephone number. A "P" will appear in the display at the corresponding location.

Changing the Display Language

1

To change the language that is used on the LCD display, take the following steps:

- 1** Press **Setup** on the operation panel. The display shows "1. SYSTEM SETUP" on the bottom line.
- 2** Press **Enter**.
- 3** Press the **Scroll** buttons (◀ or ▶) until you see "LANGUAGE" on the bottom line, then press **Enter**.
The current setting displays.
- 4** Press the **Scroll** buttons (◀ or ▶) until you see the language you want in the display.
- 5** Press **Enter** to save the selection.

Setting the Discard Size

When receiving or copying a document as long as or longer than the paper loaded in the paper bin, you can set the product to discard and excess images at the bottom of the page, so that it will fit onto the recording paper size.



NOTE: If the Auto Reduction feature is turned ON for printing faxes, this function is not performed.

- 1** Press **Setup**. The display shows "1.SYSTEM SETUP" on the bottom line.
- 2** Press **Enter**.
- 3** Press the **Scroll** buttons (◀ or ▶) until you see "DISCARD SIZE" and then press **Enter**.
- 4** Enter the desired discard size using the number keypad.

The received or copied page within the margin you set will be discarded.

If the data is outside the margin you set, it will be printed on two sheets of paper at the actual size.

- 5** Press **Enter** to save the selection and return to Standby mode.

Setting Sounds

You can set the following sounds:

- **Ringer Volume:** You can adjust the ringer volume. Choose from HIGH, MED, LOW, or OFF. OFF setting turns the ringer off.
- **Alarm Sound:** You can turn the alarm sound on or off. If set to ON, an alarm sounds when an error occurs.
- **Key Sound:** You can turn the key tone on or off. If set to ON, key tone sounds are heard when a key is pressed.
- **Speaker Volume:** You can adjust the volume of the earpiece to the desired loudness.

Ringer Volume, Alarm Sound, Key Sound

- 1** Press **Setup**. The display shows "1.SYSTEM SETUP" on the bottom line.
- 2** Press **Enter**.
- 3** Press the **Scroll/Volume** buttons (◀ or ▶) until you see the desired sound you want to set and then press **Enter**. The current setting for the selected sound displays.
- 4** Press the **Scroll/Volume** buttons (◀ or ▶) until you see the desired volume setting on the display and then press **Enter** to save the selection.

Speaker Volume

- 1** Press **OHD**. You will hear a dial tone.
- 2** Press the **Scroll/Volume** buttons (◀ or ▶) until you hear the desired loudness. The display shows the selected volume level.
- 3** Press **OHD** to save the selection and return to Standby mode.

Setting Dialling Mode

You can select the type of telephone dial system your product is connected to.



NOTE: The Dialling Mode setting may be unavailable depending on your country.

- 1** Press **Setup**. The display shows "1.SYSTEM SETUP" on the bottom line.
- 2** Press **Enter**.
- 3** Press the **Scroll** buttons (◀ or ▶) until you see "DIALLING MODE" and then press **Enter**.
- 4** Press the **Scroll** buttons (◀ or ▶) to select the desired setting.

Select "TONE" if the product is connected to a tone dial line.
Select "PULSE" if the product is connected to a pulse dial line.
- 5** Press **Enter** to save the selection.

Using Save Mode

Ink Save

The Ink Save feature allows the printer to use less ink on each page. Activating this mode will extend the life of the ink cartridges by up to twice as long compared to normal mode, but will reduce the print quality.

To use the Ink Save mode, press **SAVE Ink** on the operation panel. If the button backlight is on, the Ink save mode is active and the printer uses less ink when printing from PC, receiving faxes, and printing copy pages.

If the button backlight is off, the Ink Save mode is disabled and you will print with normal quality.



NOTE: The Ink Save mode is not activated if the Paper Save mode is on or an optional photo cartridge is installed in the product.

Paper Save

This feature prints 2 pages on a single sheet of paper to save paper.

To save paper:

- 1 Press **SAVE Paper** on the operation panel. The display shows the current setting on the bottom line.
- 2 Press the **Scroll** buttons (◀ or ▶) to change the setting. To enable the Paper Save mode, select "ON". Or select "OFF" to disable the mode. Then press **Enter**.



NOTES:

- The Paper Save feature is applied only in Black Copy or Fax mode. While the Paper Save feature is enabled, you cannot enlarge or reduce the image using the **Zoom Rate** button. The copy quality is also fixed to **Normal**. You cannot change the quality using the **Quality** button unless you disable the Paper Save feature.
 - The Paper Save feature may not work when copying or receiving long documents (for example, legal size) because Auto Reduction cannot be achieved.
-

Power Save

Your product reduces power consumption when it is not in actual use. This Power Save Mode setting allows you to select the length of time the product waits after a job is printed before it switches to a reduced power state.

- 1** Press **Setup**. The display shows "1.SYSTEM SETUP" on the bottom line.
- 2** Press **Enter**.
- 3** Press the **Scroll** buttons (◀ or ▶) until you see "POWER SAVE MODE" on the display and then press **Enter**. The current setting displays.
- 4** Press the **Scroll** buttons (◀ or ▶) until you see the desired time on the display. The available options are 1 HOUR, 4 HOURS, 8 HOURS, and 12 HOURS.
- 5** Press **Enter** to save the selection.



NOTE: If the product detects a document(s) in the ADF, the Power Save mode is not activated. Do not leave documents in the ADF if not used.



2

PRINT

Read this chapter to learn how to select and load print media and how to use the print settings.

The topics included in this chapter are:

- **Paper Selection**
- **Loading Speciality Paper**
- **Printing a Document**
- **Printer Settings**
- **Using the Printer Control Program**

Paper Selection

One of the most important things you can do to assure the best possible printing performance of your product is to select the correct paper. Your product produces letter quality print on most plain bond paper, including cotton bond and photocopying paper; it does not require special ink jet paper. However, the print quality varies with different paper types. Be sure to test a type of paper before you purchase a large quantity.

Your printer supports the following types of paper. Select the right paper for the job you intend to use it for.

- **Plain Paper**

The product supports paper sizes of letter, legal, and A4 in portrait orientation. You can use regular copier paper, cotton bond papers, and typical letterhead. Always use paper without curls, folds, staples, or damaged edges.

- **Coated paper**

Paper developed for high quality printing with minimal or no smearing or running when in contact with water or damp surfaces.

- **Glossy/Photo Paper**

A high gloss, thicker paper that produces the look and feel of a photograph. Use this paper to produce photo-realistic prints from your printer.

- **Transparency**

Your transparencies should be products designed for use in Ink Jet products, with excellent contrast, sharpness, and colour quality. The transparency is placed in the product with the image side up.

- **Iron-on Transfer**

Use inkjet T-shirt transfers to create and personalize T-shirts, sweatshirts, aprons, tablecloths, napkins, tote bags, and anything else your imagination allows! Use on any cotton or cotton/poly blend fabric. Your image is printed in mirror image so when you iron it onto the T-shirt, the image is viewed correctly.

- **Greeting Card Stock**

You can create greeting cards, business cards, invitations, announcements, and more.



NOTE: When you print on these special type of media, you have to set the selected paper type in your application. See page 2.10.

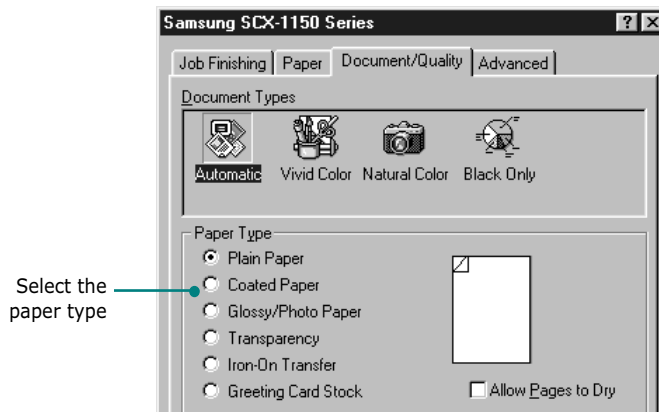

▲ In the case of Windows 98



Guidelines for Special Media

Be sure to read any instructions that come with your special paper. These instructions provide important information regarding how to achieve the highest print quality with these papers.

- It is recommended that you feed special paper types one sheet at a time.
- For transparencies and glossy photo paper, follow these guidelines:
 - Let the printed sheets dry completely before storing them.
 - When a printed sheet has dried completely, cover the printed side with a sheet of plain (not coated) paper before storing it, this is recommended even if you place the sheets in a clear file or plastic holder.
 - Do not leave the film in the paper output tray for long periods of time. Dust and dirt may accumulate on the film resulting in spotty printing.
 - To avoid smudging caused by fingerprints, handle transparency film and coated paper carefully.
 - To avoid fading, do not expose the printed film to prolonged sunlight.
- Store unused media flat. Do not remove paper from their protective packaging until you are ready to use them.

- Store unused media at temperatures between 59 and 86 °F (15 to 30 °C). The relative humidity should be between 10% and 70%.
- If the print density of your page is very high, light paper stock may curl slightly due to the large amount of ink. If you need to print dense graphics, try printing on heavier stock.
- Do not use thicker paper than meets the specifications for this product. Printing with a paper that is thick enough to come in contact with the print head nozzles may damage the cartridge.

Loading Speciality Paper

Follow these guidelines when loading specialty paper:

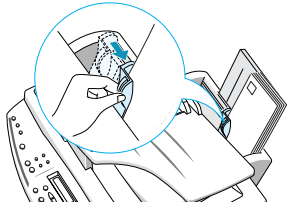
| Load up to: | And make sure: |
|---|---|
| 100 sheets of plain paper (depending on thickness) | <ul style="list-style-type: none"> • The print side is facing you. • The paper is against the right side of the paper support. |
| 10 envelopes | <ul style="list-style-type: none"> • The print side is facing you. • The envelopes are loaded vertically against the right side of the paper support. • The stamp location is in the upper left corner. • The paper guide rests against the edge of the envelopes.  |
| 10 greeting cards, index cards, postcards, or photo cards | <ul style="list-style-type: none"> • The print side is facing you. • The cards are loaded vertically against the right side of the paper support. • The paper guide rests against the edge of the cards. |
| 25 sheets of photo paper | <ul style="list-style-type: none"> • The glossy or coated side is facing you. • The paper guide rests against the edge of the photo paper. |

| Load up to: | And make sure: |
|---------------------------------|--|
| 10 transparencies | <ul style="list-style-type: none"> • The rough sides of the transparencies are facing you. • The paper guide rests against the edge of the transparencies. |
| 100 sheets of custom size paper | <ul style="list-style-type: none"> • The print side is facing you. • Your paper size fits within these dimensions: <ul style="list-style-type: none"> - Width: 76 mm to 216 mm (3.0 in. to 8.5 in.) - Length: 127 mm to 432 mm (5.0 in. to 17.0 in.) • The paper guide rests against the edge of the paper |
| 25 iron-on transfers | <ul style="list-style-type: none"> • You follow the loading instructions on the iron-on packaging. • The print side (blank side) is facing you. • The paper guide rests against the edge of the iron-on transfers. |

Paper Guidelines

When loading paper, envelopes, or other special media, keep these guidelines in mind:

- Attempting to print on damp, curled, wrinkled, or torn paper can cause paper jams and poor print quality.
- Use only high quality inkjet or copier grade paper. Avoid paper with embossed lettering, perforations, or texture that is too smooth or too rough.
- Store paper in its ream wrapper until ready to use. Place cartons on pallets or shelves, not on the floor. Do not place heavy objects on top of the paper, whether it is packaged or unpackaged. Keep it away from moisture, or other conditions that can cause it to wrinkle or curl.
- During storage, moisture-proof wrap (any plastic container or bag) should be used to prevent dust and moisture from contaminating your paper.
- Always use paper and other media that conform with those listed under "Paper Specification" on page 8.5.
- Use only well-constructed envelopes with sharp, well creased folds.
- DO NOT use envelopes with clasps and/or snaps.
- DO NOT use envelopes with windows, coated linings, self-adhesive seals, or other synthetic materials.
- DO NOT use damaged or poorly made envelopes.

Printing a Document

This procedure describes the general steps required for printing from various Windows applications. The exact steps for printing a document may vary depending on the application program you are using. Refer to your software application's documentation for the exact printing procedure.

The following steps describe the typical process to print from a Windows environment:

- 1** Ensure that your Samsung SCX-1150F is properly connected to the computer, the product is powered on, and there is paper in the paper bin.
- 2** Verify that you have installed the Samsung software for your computer. For details, see "Installing Samsung Software" on page 1.20.
- 3** Start the program you are using to create the document, and create or open the document you want to print.
- 4** Choose **Print** or **Print Setup** from the **File** menu. Make sure that **Samsung SCX-1150 Series** is selected as your default printer. Click **Properties** or **Setup** if you want to make any adjustments that are appropriate for printing your document. (For details, see "Printer Settings" on page 2.8.)



- 5 Click **OK** to close the Properties dialog box.
- 6 After making any necessary changes to the printing parameters, click **OK** to start the print job.

After a moment, the Samsung SCX-1150 Series Control Program window appears. You can cancel the print job as well as see how much ink you have left and view printing tips in this window.



▲ In the case of Windows 98. The appearance of this window may be different depending on your Windows operation system.

For Windows 2000/XP, the Control Program does not appear. Right-click on the printer icon on the taskbar at the bottom right corner of the desktop window. From the pop-up menu, you can select commands to cancel, pause, or resume printing.



NOTE: If you want to use another printer instead of SCX-1150F, you must disable the scan monitor on the taskbar at the bottom right corner of the desktop window. The scan monitor is enabled as long as SCX-1150F is connected to your computer and turned on. To disable the scan monitor, right-click on the scan monitor and select **Disable** from the pop-up menu.

Printer Settings

You can use the product with all your Windows 95/98/Me/2000/XP or Windows NT 4.0 applications. Be sure to set Samsung SCX-1150 Series as the default printer for all your Windows operations.

Most Windows software applications allow you to make changes to the printer settings. This includes settings that determine how a print job looks such as paper size, paper orientation, and margins. Settings made in the application to create the document will usually override settings made in the printer driver.



NOTE: You do not need to use any of the operation panel buttons to use the product as a PC printer. For example, if you want to adjust the printing contrast you do not have to press **Contrast** on the operation panel. The operation panel buttons are used primarily for copying.

Accessing Printer Settings

You can access printer settings by using either of these methods.

Windows 95/98/Me

- Select the **File > Print > Properties** or **File > Print Setup** command from within any Windows application.

Or

- Select **Samsung SCX-1150 Series** printer from the **Printers** folder, then select **File > Properties** (or select the printer icon in the **Printers** folder, and click the right mouse button).

Windows NT 4.0

- Select the **File > Print > Properties** or **File > Print Setup** command from within any Windows application.

Or

- Select **Samsung SCX-1150 Series** printer from the **Printers** folder, click the right mouse button, then select **Document Defaults** from the drop-down list.

Windows 2000/XP

- Select the **File > Print > Properties** or **File > Print Setup** command from within any Windows application.

Or

- Select **Samsung SCX-1150 Series** printer from the **Printers** folder, click the right mouse button, then select **Printing Preferences** from the drop-down list.



Printer Properties Tabs (Windows 95/98/Me)

When the Printer Properties are displayed, you can review and change whatever settings are needed for your printer job.

Your printer's Properties window consists of 4 tabs: **Paper**, **Quality**, **Job Finishing** and **Advanced**.

If you access the Printer Properties through the **Printers** folder, you can view more Windows-based tabs, as well as these 4 tabs. For information on the Windows-based tabs, refer to your Windows User Guide.



NOTE: If you access the Printer Properties through the **Printers** folder, any settings made will become the default settings for the printer. Settings made when the Printer Properties are accessed through an application **File** menu and **Print** or **Print Setup** will remain active until the application you are printing from is closed.

Paper Tab

Use the **Paper** tab to select what size paper you have in your printer, the orientation, the number of copies to print, etc.

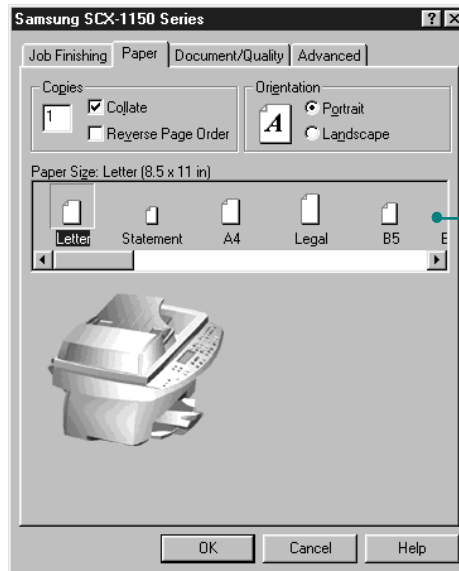

Select the paper size you have loaded in your printer. If you have a special size of paper to print on, select **Custom** and define its size in the custom settings. The minimum paper size you can use is 3 by 5 inches. The maximum size is 8.5 by 17 inches.

Document/Quality Tab

The **Document/Quality** tab controls the document type and the paper type, such as plain, coated, and glossy. It also controls the quality (resolution) of the printing. Higher resolutions print better, but take longer and consume more ink. Selecting **Web Smoothing** allows you to print clearer images from the Internet.

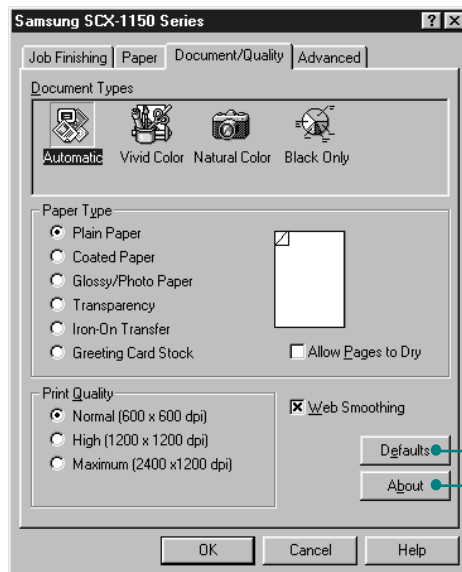

Resets to the default settings.

Shows the printer driver version.

Job Finishing Tab

The **Job Finishing** tab provides options for you to adjust how the document will appear on the printed page. **Job Finishing** options can include **Poster**, **Handout**, **Booklet** and **Two-sided printing**.

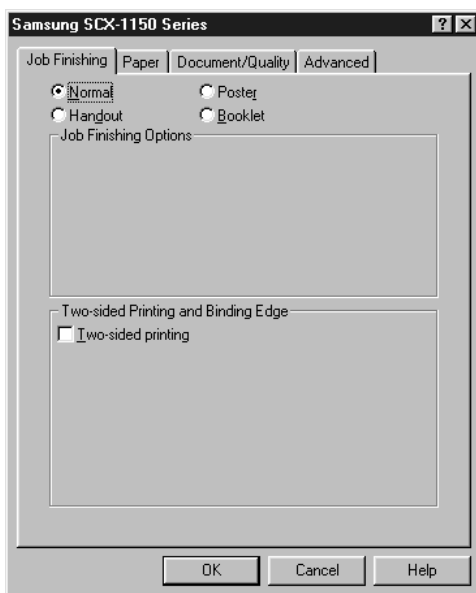

Booklet

The Booklet option allows you to print a document out as a booklet. If the **Print reloading instructions after the first side prints** is checked, a page will print directing you how to insert the paper so that the booklet prints correctly.

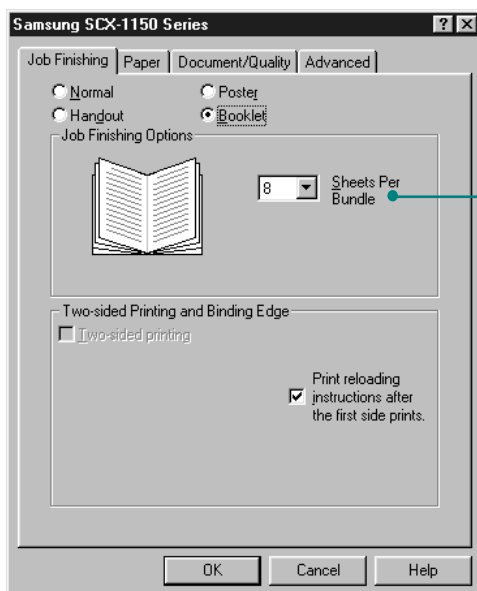

A bundle is any number of sheets of paper folded together. When printing with a heavier paper stock, select a smaller number of Sheets Per Bundle.

Once your document prints, stack the bundles and bind the booklet.

- 1 Take the first bundle from the paper output tray, fold it in half, and set it aside.
- 2 Fold and stack the rest of your bundles, one on top of the other, until your booklet is complete.
- 3 Bind the bundles.



Poster

Choose the **Poster** option to enlarge the printed document. If you check **Show Crop Marks**, the image will print with crop marks. The white space around the image can easily be trimmed.

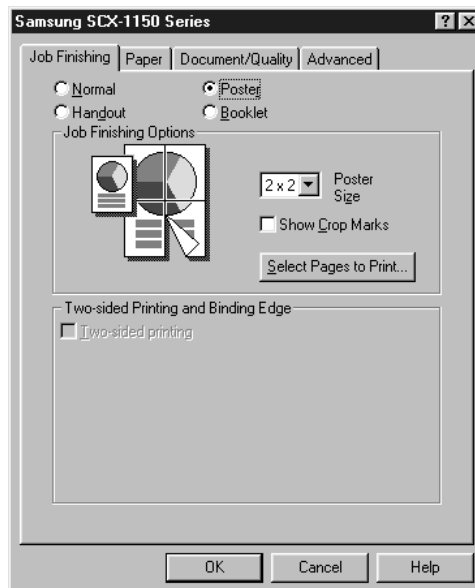

Handout

Choose the **Handout** option to print multiple pages on a single sheet of paper.

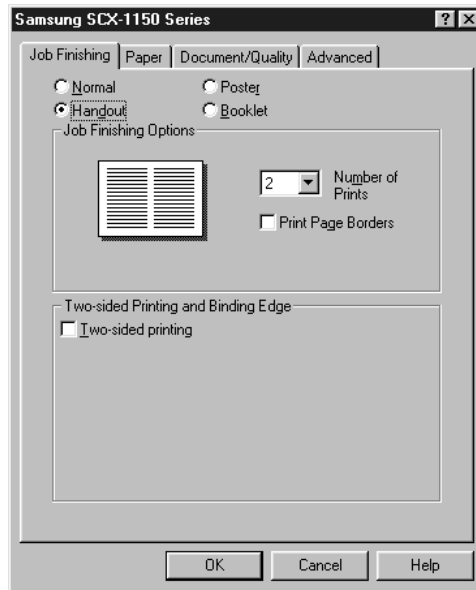

Two-Sided Printing

Choose the **Two-sided printing** option from the **Job Finishing** tab to print the document on both sides of the paper.

Advanced Tab

The **Advanced** tab allows you to change how the printer handles colour printing. You should rarely need to change these settings.

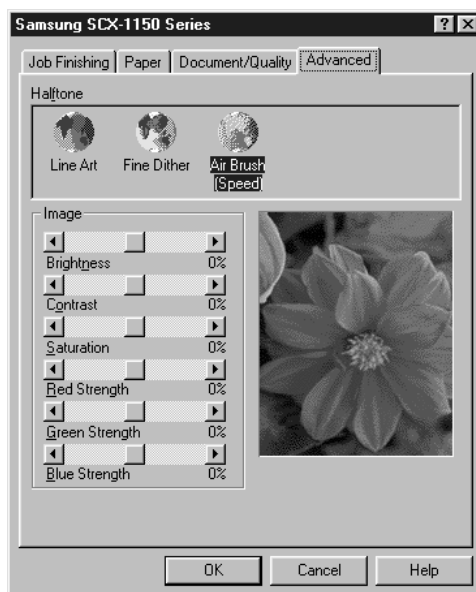

Printer Properties Tabs (Windows NT 4.0)

Page Setup Tab

This tab allows you to set page properties including number of copies, collate, print quality, orientation, reverse order printing, paper size, and paper type.

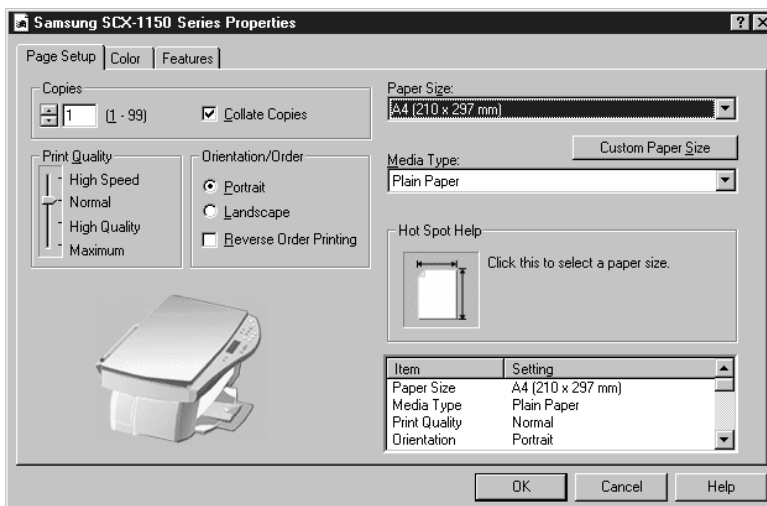

Color Tab

Use the **Color** tab for optimising the graphic and colour print job. You can adjust halftone shading, brightness and contrast. You can also select the colour appearance and the document colour.

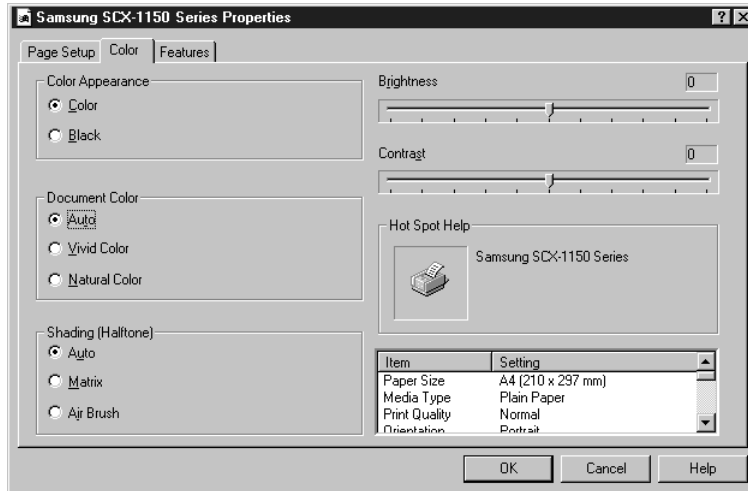

Feature Tab

You can select the Dry Time Delay option and the two-sided printing option. You can also access Cartridge Maintenance features from this tab.

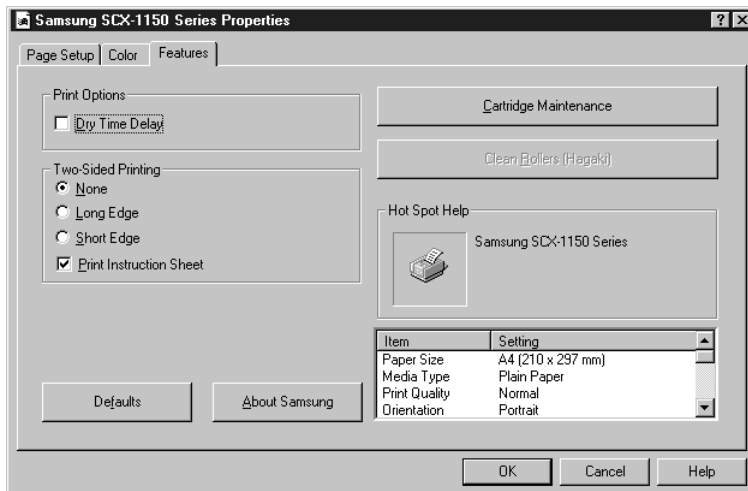

NOTE: In Windows NT 4.0, Poster, Handout, and Booklet printing are not provided.

Printer Properties Tabs (Windows 2000/XP)

Paper Quality Tab

This tab allows you to select paper source, paper type, print quality, and colour. The **Advanced** button under this tab allows you to select advanced document settings including paper size, print resolution, and colour intent.

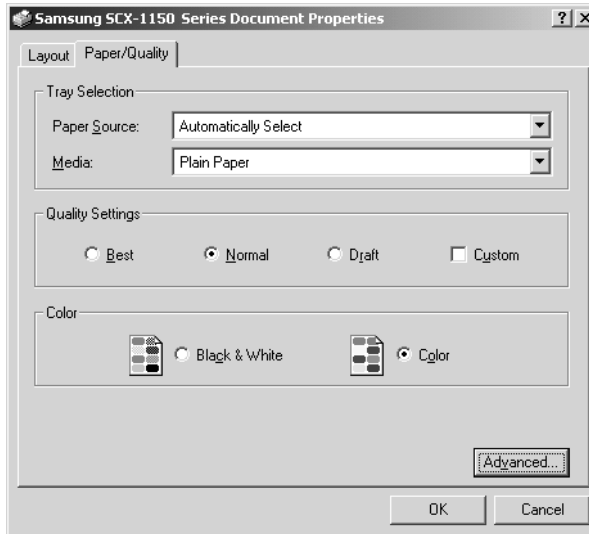

Layout Tab

Use the **Layout** tab to select print orientation, and page order.

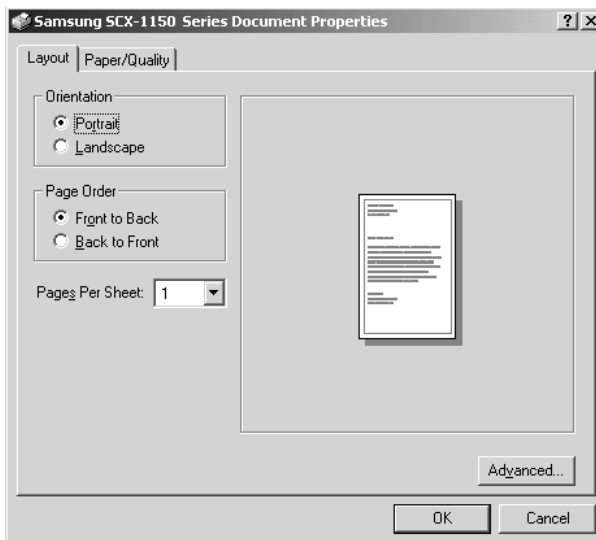

Printer Properties Buttons & Icons

- Click **OK** when done reviewing or making changes.
- Click **Cancel** if you want to exit the tab menus without applying any changes.
- Click **Help** to view the online Help feature and tab menu details.
- Click the **?** icon in the title bar. Position the **?** pointer over the parameter in question and click to see a pop-up window explaining that parameter.

Using the Printer Control Program

The SCX-1150 Series Control Program contains setup options that define the operation of your product.



NOTE: The Printer Control Program is not available in Windows 2000 and Windows XP.

Accessing the Printer Control Program

- 1** Click **Start > Programs > SAMSUNG SCX-1150 Series > Printer Control Program**.



NOTE: Windows NT 4.0 users can also access the Printer Control Program from the Printer Properties window. See 2.15.

- 2** The Samsung SCX-1150 Series Control Program window appears. The appearance of the window may be different from the ones on page 2.18 depending on your Windows operating system. Click the appropriate tab for the options you want to display, and make the necessary changes on each tab.



NOTE: Click **Help** on any tab in the Control Program window to access on-line Help.

Status Tab

The **Status** tab gives you general status information on the printer. You will see this window when the printer is printing (unless you've set the Control Program Options to **Run Minimized**, using the options on page 2.18).

Once a print job has started, you can use this window to cancel the print job or monitor the job progress.

The ink level of your cartridges is also displayed. Use the gauges to help you determine when they need replacing.



NT 4.0 provides this button in the Cartridge tab.

◀ In the case of Windows 98

Options Tab

From the **Options** tab, you can control some of the behaviour of the Control Program. The options available will vary depending on your Windows operating system. Some of the options activate under a specific printing environment such as network printing. Click **Help** for further information.



◀ In the case of Windows 98

Cartridges Tab

The **Cartridges** tab gives you access to several different cartridge functions. From here, you can install new cartridges, change them, clean your print nozzles, align your cartridges, or order supplies from the internet.

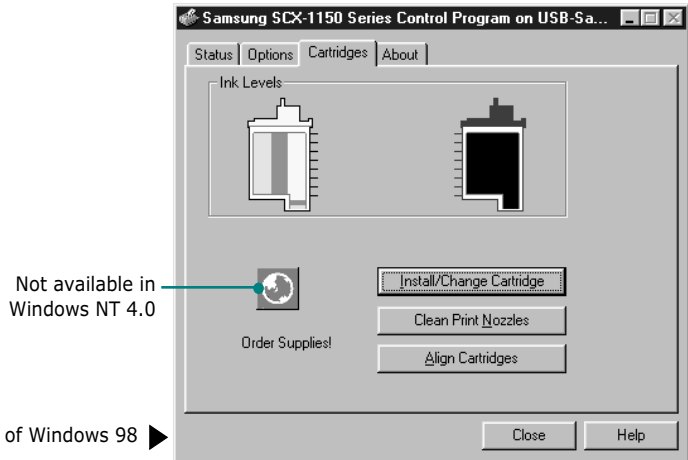

NOTE: If you using Windows 2000/XP, you can access the Cartridge Maintenance features through the printer properties by taking the following steps:

1. Click **Start > Settings > Printers**.
2. Right-click on **Samsung SCX-1150 Series** printer in the Printers folder.
3. From the pop-up list, select **Properties**.
4. Click the **Cartridge Maintenance** tab.

About Tab

The **About** tab gives you the program version number. If you click on the globe image on the window, you will be connected to the Samsung web site provided you are an internet user.

NOTE



3

COPY

You can use your product like a standard copier. You don't even have to turn your computer on. The buttons on the operation panel let you make all the basic settings: paper type and size, copy size, copy contrast and quality, number of copies, and colour copy or black and white copy.

This chapter includes:

- **Setting Paper Size and Type**
- **Loading the Original Documents**
- **Copying a Document**
- **Setting Copy Options**
- **Using Special Copy**
- **Changing Default Settings**
- **Blocking Colour Copying**

Setting Paper Size and Type

First make sure you have paper loaded, following the instructions in “Loading Paper” on page 1.11. Then you have to set the paper size and type using the operation panel buttons.



NOTE: These settings are applied to the stand-alone copy mode only. In PC printing mode, you have to select the paper type and size in the application program you use.

Paper Size

After loading paper, take the following steps to set the paper size from the operation panel:

- 1** Press **Setup**. The display shows “1.SYSTEM SETUP” on the bottom line.
- 2** Press the **Scroll** buttons (◀ or ▶) until you see “3. COPY SETUP” and then press **Enter**.
- 3** The first copy setup menu “PAPER SIZE” appears on the bottom line. Press **Enter**.

The current setting is tagged with a ◀ at the end of the display on the bottom line.
- 4** Press the **Scroll** buttons (◀ or ▶) until you see the paper size you are using in the display.
- 5** Press **Enter** to save the selection.



NOTE: When you use legal-size paper, do not pull out the paper output tray. If you do, a paper jam may occur.

Paper Type

You can use special media such as inkjet, transparency, and photo paper as well as plain paper. After loading any special type of media, set the paper type using this menu:

- 1** Press **Setup**. The display shows "1.SYSTEM SETUP" on the bottom line.
- 2** Press the **Scroll** buttons (◀ or ▶) until you see "3. COPY SETUP" and then press **Enter**.
- 3** Press the **Scroll** buttons (◀ or ▶) until you see "PAPER TYPE" on the bottom line of the display.
- 4** Press **Enter**. The current setting is tagged with a ◀ at the end of the display on the bottom line.
- 5** Press the **Scroll** buttons (◀ or ▶) until you see the paper type you are using in the display.
- 6** Press **Enter** to save the selection.



Loading the Original Documents

You can use the Automatic Document Feeder (ADF) or the document glass to load an original document for sending, copying and scanning.

Your ADF can load up to 30 sheets at a time. When you load multipage documents of the same thickness and weight, you can use the ADF.

If you want to load booklet, pamphlet, or documents having unusual characteristics, you have to use the document glass and load one sheet at a time. On the document glass, you can load the following types of documents:

- Thick paper
- Document with uneven surface
- Photographs
- Small documents (e.g. business cards, postcards)
- Special types of paper

Using Automatic Document Feeder (ADF)

- 1 Insert your document face up, with the top edge leading into the ADF. Adjust the document guides to the width of the document.

You can insert up to 30 sheets at a time.

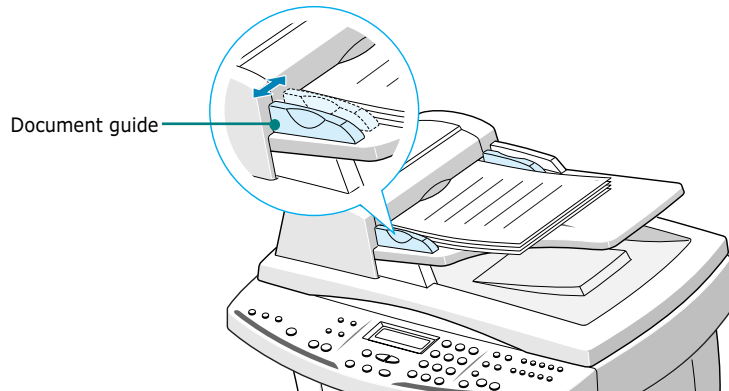

- 2 Gently feed it in until "DOCUMENT READY" appears in the display.

Problem Documents

- To prevent document jams in the ADF, do not use any of the following:
 - Wrinkled or creased paper
 - Carbon paper or carbon-backed paper
 - Curled or rolled paper
 - Coated paper
 - Torn paper
 - Onion skin or thin paper
- Remove all staples, paper clips, or any other fasteners before loading the document into the ADF.
- Make sure any glue, ink, or correction fluid on the paper is completely dry before loading the document into the ADF.
- If you have a document that will not feed properly into the ADF, make a photocopy of the document and load the copy instead.

Using Document Glass

- 1 Open the document cover.

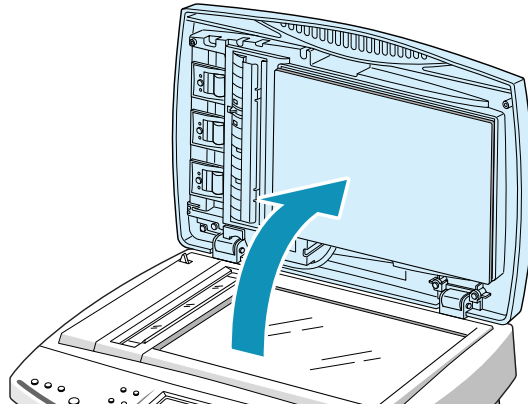

3

- 2 Place the document face down on the document glass. Position it so the horizontal and vertical edges are carefully aligned with the scales along the sides of the document glass.

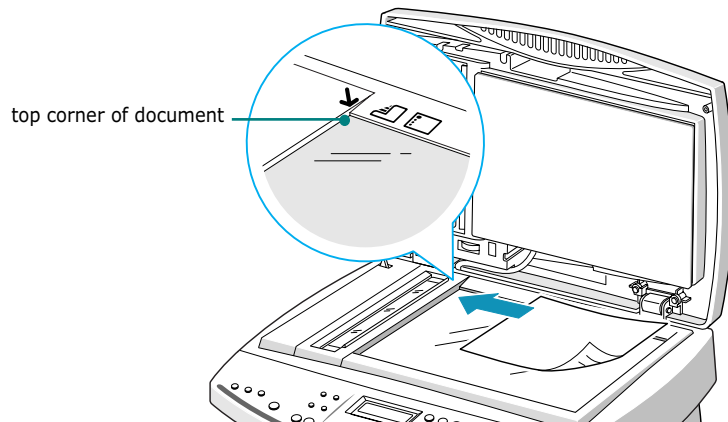

- 3 Close the top cover slowly. Be careful not to move the document.
- 4 When you finish setting procedure for copying, sending, or scanning, the first page on the document glass is scanned, then the display shows "NEXT GO ON?" on the top line.

If you have next page, remove the scanned page and load the next page on the glass and press **Enter**. Repeat as necessary. When all pages are scanned, press **Cancel/Reset** when the display shows "NEXT GO ON?"

If you want to copy or scan a book:

You can remove the top cover to place an original document such as a book.

Lift the cover straight up to remove it.



NOTE: Be careful as the ADF plug on the cover is connected to the main body.

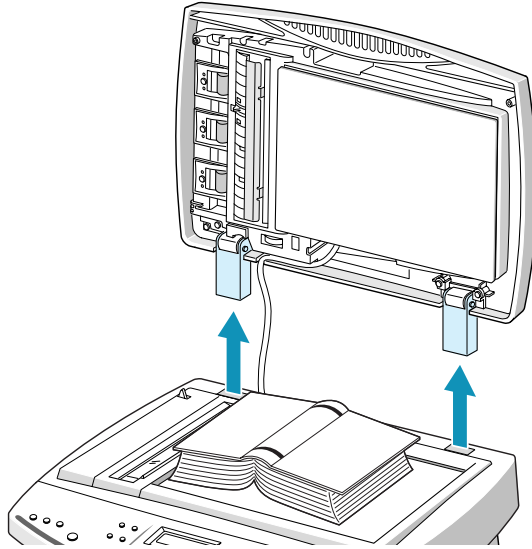

To insert the cover in place, hold it as shown and insert its hinges into the holes. Then close the top cover.

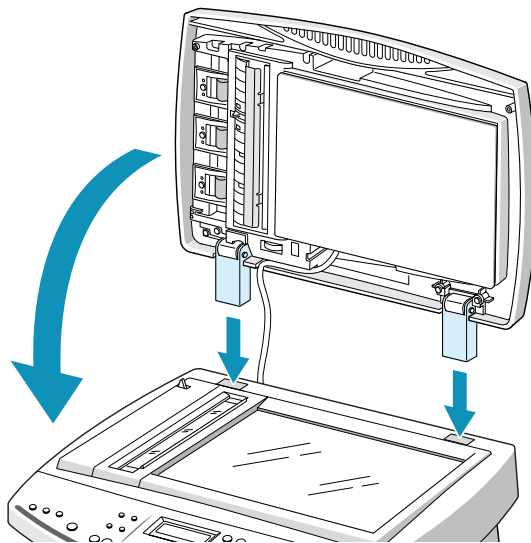

Copying a Document

Follow these steps to copy using the operation panel:

- 1 Feed the document(s) to be copied **face up** into the ADF until "DOCUMENT READY" appears in the display.

Or

Place a single document on the document glass **face down** then close the cover.

For details on loading original document(s), see page 3.3.

- 2 Customise the copy settings including copy quality, contrast, number of copies, and copy size if necessary. See "Setting Copy Options" on page 3.8.
- 3 When you are finished setting the copy options, press **Start Copy Black** to begin a black and white copy, or press **Start Copy Color** for a colour copy.

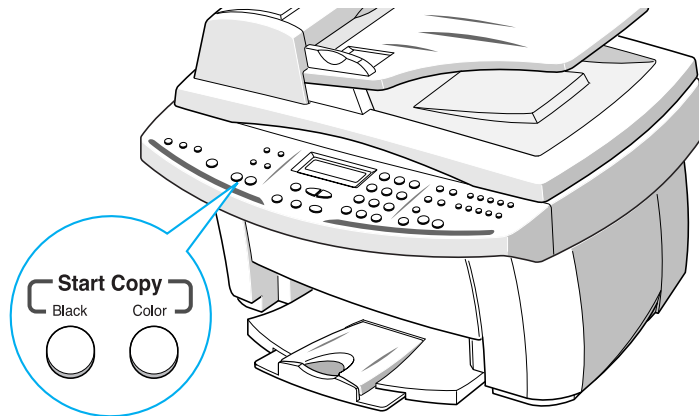

NOTES:

- You can set the user default copy settings which will apply when copying documents unless you change the settings for the individual copy job. See "Changing Default Settings" on page 3.15.
- If an optional photo cartridge is installed in the product, you cannot use a black and white copy.
- If you want to cancel the copy job, press **Cancel/Reset** during copying.

Setting Copy Options

The following buttons on the operation panel let you make all the basic settings: copy quality, contrast, number of copies and copy size.



NOTE: The option settings for the current copy job will be automatically reset to their default status (see 3.15) 2 minutes after the job is completed. If necessary, you can reset the copy option immediately by pressing **Cancel/Reset**.

Quality

To select the copy quality, use the **Quality** button on the operation panel. You can select BEST, NORMAL, or DRAFT. The BEST mode is good for documents with fine details. The copy quality is good but the copy speed is low. The NORMAL mode works well for normal documents (text). The DRAFT mode can be used for fast copying with lower resolution.

To select copy quality:

- 1 Press **Quality**. The current setting is tagged with a ◀ at the end of the display.
- 2 Scroll through the options available by pressing **Quality** repeatedly or using the **Scroll** buttons (◀ or ▶).
- 3 When the desired mode is displayed, press **Enter** to save the selection.



NOTES:

- While the **Paper Save** mode is enabled, the print quality you selected through the **Quality** button is ignored and automatically applied to "NORMAL."
 - With an optional photo cartridge installed in the product, if you select the DRAFT setting, the display shows "LOAD BLACK INK" when you start copying and the product cannot print.
-

Contrast

You can adjust the contrast for a document containing faint markings or dark images or photographs using the **Contrast** button. You can select LIGHTEN, DARKEN, PHOTO or NORMAL. The LIGHTEN contrast is good for documents containing dark images. The NORMAL contrast works well with a standard document. The DARKEN contrast works well with light print or faint pencil markings. Choose the PHOTO contrast if you are copying a photograph.

To select the contrast:

- 1** Press **Contrast**. The current setting is tagged with a ◀ at the end of the display on the bottom line.
- 2** Scroll through the options available by pressing **Contrast** repeatedly or using the **Scroll** buttons (◀ or ▶).
- 3** When the desired mode is displayed, press **Enter** to save the selection.



Copy page

You can select the number of copies, from 1 to 99. To change the number of copies:

- 1** Press **Copy page**.
- 2** Enter the number of copies using the number keypad. Use a 2-digit number.
- 3** When the desired quantity is displayed, press **Enter** to save the selection.



NOTE: If you load a document in the ADF, you cannot print multiple color copies. The product prints only 1 copy when you start color copying and the document is fed from the ADF. If you want to print multiple color copies, you must use the document glass.

Zoom rate

You can reduce or enlarge the size of a copied image from 25% to 400% using the **Zoom Rate** button on the operation panel.

To select the zoom rate from pre-defined copy sizes:

- 1 Press **Zoom Rate** until the setting you want appears on the display.
- 2 Press **Enter** to save the selection.

To fine-tune the size of copies:

- 1 Press **Zoom Rate** until you see "CUSTOM 100% (◀ ▶)" on the display and then press **Enter**.
- 2 Enter the desired rate using the number keypad.
- 3 Press **Enter** to save the selection.



NOTES:

- While the **Paper Save** mode is enabled, the zoom rate you selected is ignored.
 - If you are copying from ADF, the zoom rate ranges from 25% to 100%.
-

Collating

When the Collate option is set to ON, your product sorts the copy job. For example, two copies of a three-page job will print one complete document followed by the second complete document (e.g. 1,2,3 then 1,2,3).

- 1 Press **Setup**. The display shows "1.SYSTEM SETUP" on the bottom line.
- 2 Press the **Scroll** buttons (◀ or ▶) until you see "3.COPY SETUP" and then press **Enter**.
- 3 Press the **Scroll** buttons (◀ or ▶) until you see "COLLATE" on the bottom line of the display.
- 4 Press **Enter**. The current setting is tagged with a ◀ at the end of the display on the bottom line.
- 5 Press the **Scroll** buttons (◀ or ▶) to select "ON" or "OFF."

6 If you selected "COLLATE ON", the next display prompts you to select the print order. Press the **Scroll** button (◀ or ▶) to select "NORMAL" or "REVERSE". If you selected "REVERSE", the 3 pages print in this order: 3, 2, 1.

7 Press **Enter** to save the selection.



NOTES:

- Collation feature is available only when you make a black and white copy from ADF.
 - If memory gets full while the product scans the documents, the collation feature will be automatically disabled and the product will not collate the copy outputs.
-

Using Special Copy

You can use the following copy features using the **Special Copy** button on the operation panel:

- **Fit to Page:** Reduces or enlarges an image from 25% to 400% to fit onto a full page.
- **Clone:** Reduces or enlarges the copy image to fit to a selected frame size and then prints several copies of the image on the same page. You can also specify the number of images to be printed.
- **Poster:** Prints an image on multiple pages. Select 2x2 to print a 4 page poster, 3x3 to print a 9 page poster or 4x4 to print a 16 page poster. The image is automatically enlarged by up to 400% to fit onto the selected poster size.
- **Mirror:** Prints the reversed image of your original document. Use this feature to copy favourite photos or images onto Iron-on T-shirt transfer and then iron the transfer sheet to make a custom T-shirts, banners, and flags.
- **Normal:** Prints in normal mode.



NOTES:

- The special copies are available only when you load document using the document glass. The special copies do not work with the ADF.
 - When the Paper Save mode is enabled, any changes you made through these special copy features do not apply even though it seems to be accessible, and the print quality is applied to "NORMAL."
-

Fit to Page

- 1** Place a single document on the document glass **face down** then close the cover.
For details on loading an original document, see page 3.5.
- 2** Customise the copy settings including copy quality, contrast, and number of copies if necessary. See "Setting Copy Options" on page 3.8.
- 3** Press **Special Copy**. "FIT TO PAGE" appears on the bottom line of the display.
- 4** Press **Enter**.
- 5** Press **Start Copy Black** to begin black and white copying. To make a colour copy, press **Start Copy Color**.



NOTE: When the **Fit to Page** printing is enabled, the zoom rate you previously selected, if any, is ignored.

Clone

- 1** Place a single document on the document glass **face down** then close the cover.
For details on loading an original document, see page 3.5.
- 2** Customise the copy quality and contrast if necessary. See "Setting Copy Options" on page 3.8.
- 3** Press **Special Copy**.
- 4** Press the **Scroll** buttons (◀ or ▶) until you see "CLONE" on the bottom line of the display, then press **Enter**.
- 5** Press the **Scroll** buttons (◀ or ▶) until you see the desired frame size, then press **Enter**.
- 6** Press **Copy Page** and enter the number of the image by using the number keypad and press **Enter**.

- Press **Start Copy Black** to begin black and white copying. To make a colour copy, press **Start Copy Color**.



NOTE: When making a clone, the zoom rate you previously selected, if any, is ignored.

Maximum number of images on one sheet of paper:

| Frame Size | Maximum Copies | |
|------------|----------------|----------|
| | Landscape | Portrait |
| 1.5 x 2" | 16 | 12 |
| 2.5 x 3" | 9 | 6 |
| 3.5 x 5" | 4 | 3 |
| 4 x 6" | 1 | 2 |
| 5 x 7" | 1 | 2 |
| 8 x 10" | 1 | 1 |

3

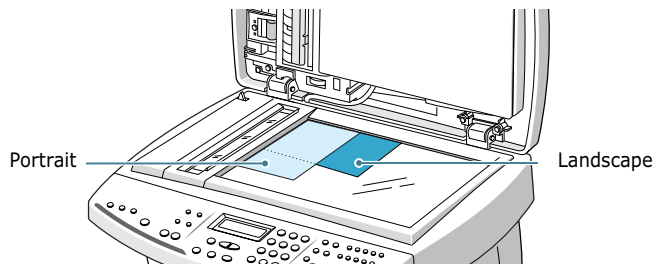

Poster

- Place a single document on the document glass **face down** then close the cover.

For details on loading an original document, see page 3.5.

- Customise the copy settings including copy quality, contrast, and number of copies if necessary. See "Setting Copy Options" on page 3.8.

- Press **Special Copy**.

- 4** Press the **Scroll** buttons (◀ or ▶) until you see "POSTER" on the bottom line of the display, then press **Enter**.
- 5** Press the **Scroll** buttons (◀ or ▶) until you see the desired poster size on the display. The following options are available: 2x2, 3x3, 4x4.
- 6** Press **Enter** to save the selection.
- 7** Press **Start Copy Black** to begin black and white copying. To make a colour copy, press **Start Copy Color**.



NOTE: When printing a poster, the zoom rate you previously selected, if any, is ignored.

Mirror

- 1** Place a single document on the document glass **face down** then close the cover.
For details on loading an original document, see page 3.5.
- 2** Customise the copy settings including copy quality, contrast, number of copies, and zoom rate if necessary. See "Setting Copy Options" on page 3.8.
- 3** Press **Special Copy**.
- 4** Press the **Scroll** buttons (◀ or ▶) until you see "MIRROR" on the bottom line of the display, then press **Enter**.
- 5** Press **Start Copy Black** to begin black and white copying. To make a colour copy, press **Start Copy Color**.

Changing Default Settings

The copy options including copy quality, contrast, number of copies and copy size can be set to the most frequently used modes. When a document is copied, the default settings will be activated unless otherwise changed by using the corresponding buttons on the operation panel.

To create your own default settings:

- 1** Press **Setup**. The display shows "1.SYSTEM SETUP" on the bottom line.
- 2** Press **Enter**.
- 3** Press the **Scroll** buttons (◀ or ▶) until you see "SET DEFAULT" on the bottom line and then press **Enter**.

With this menu, you can set the default contrast, quality, number of copies, and zoom rate which will be used in Copy mode.



NOTE: Resolution setting is not applied to the Copy mode.

- 4** Press the **Scroll** buttons (◀ or ▶) to select the option menu and then press **Enter**.
- 5** Press the **Scroll** buttons (◀ or ▶) to select the settings you want to use as default. Use the number keypad to enter the default number of copies or set the custom zoom rate.
- 6** Press **Enter** to save the selection.
- 7** Repeat as necessary.



NOTE: When you adjust copy settings or set special copy option, if you press **Cancel/Reset**, the settings are cancelled and return to their default status.

Blocking Colour Copying

You can prevent unauthorized use of colour copying by requiring a special PIN (Personal Identification Number) to use colour copying.

Take the following steps to activate this feature and set the PIN:

- 1** Press **Setup**. The display shows "1.SYSTEM SETUP" on the bottom line.
- 2** Press **Enter**.
- 3** Press the **Scroll** buttons (◀ or ▶) until you see "PIN CODE" on the bottom line of the display.
- 4** Press **Enter**.
- 5** Press **Scroll** button (◀ or ▶) to select "ON" to activate this feature or "OFF" to disable this feature.
- 6** If you selected "ON", the next display prompts you to enter the PIN code number. Use the number keypad to enter the PIN. It is preset to 0000.
- 7** Press **Enter** to save the selection.

Note that you have to enter the PIN when the display prompts to activate colour copying .



4

SCAN

Scanning with the Samsung SCX-1150F lets you turn pictures and text into digital files on your computer. Then you can fax or e-mail the files, display them on your web site, or use them to create projects that you can print out using Samsung SmarThru software which came with your product.

This chapter includes:

- **Scanning Basics**
- **Starting Scan from the Operation Panel**
- **Scanning Process with TWAIN-enabled Software**

Scanning Basics

Your SCX-1150F offers three ways to start scanning. These include:

- From the Samsung SmarThru software: Launch Samsung SmarThru and open the Scan Wizard to start scanning. Please refer to the SmarThru User's Guide.
- From the operation panel on your product: Use the **Scan to** button on the operation panel to initiate scanning. SmarThru system launches automatically and the Scan Wizard window opens on the desktop window.
- From TWAIN-compliant software: You can use other software including Adobe PhotoDeluxe and Adobe Photoshop.



NOTES:

- To scan with your product, you must install the MFP driver.
 - Scanning is through the same LPT or USB port which is currently assigned for your printer port.
-

Starting Scan from the Operation Panel

You can quickly start scanning from the operation panel on your product. The Samsung SmarThru program automatically launches and allows you to select the desired scan service. Take the following steps:

- 1** Make sure that your computer and SCX-1150F are turned on. You will see the scan monitor icon on the taskbar at the bottom right corner of the desktop window unless you disable or turn off the scan monitor.



Scan monitor

- 2** Feed the document(s) to be copied **face up** into the ADF until "DOCUMENT READY" appears in the display.

Or

Place a single document on the document glass **face down** then close the cover.

For details on loading original document(s), see page page 3.3.

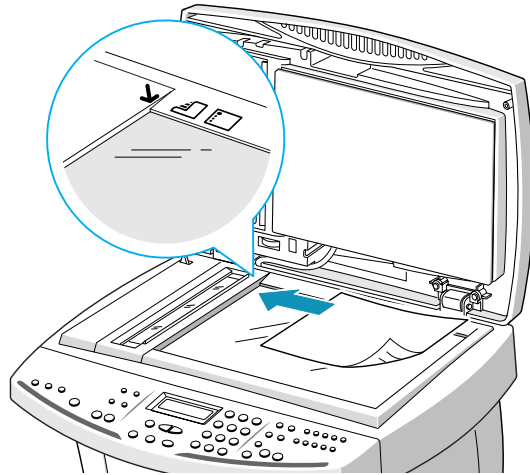

4

- 3** Press **Scan to** on the operation panel.

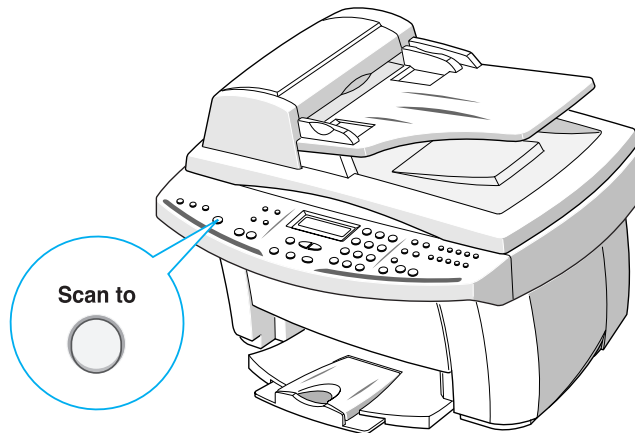

NOTE: If you press **Scan to** when the scan monitor on the desktop window is disabled or turned off (see page 4.2), "PC NOT AVAILABLE" appears on the display and you cannot achieve scanning.

- 4 The Samsung SmarThru launches automatically and the Scan Wizard window opens.



The Scan Wizard lets you use the following services:

- **Scan**
Lets you scan the original documents and save them in the Image Manager of the Samsung SmarThru system. The Image Manager is an image database manager and image editor program.
- **Copy**
Lets you use your product to produce professional quality copies. You can adjust the image size and make advanced settings.
- **Scan to Email**
Lets you scan the original document then launches a New Message form to send the just scanned image attached to a new mail. The email account must be configured in the Samsung SmarThru system to enable e-mail service.
- **Scan to FAX**
Lets you scan the original documents then launches a New Fax form which helps you send them as a fax image.
- **Scan to WEB**
Lets you scan the original documents for further publishing to the Web.

- **Scan to OCR**

Lets you scan the original documents and pass them to the OCR program. OCR (Optical Character Recognition) is the process of converting a scanned image into text that you can edit in a word processing program. After you scan your document, the software processes or "recognises" it. Then you can edit it and either save the file or open it in any word processing program on your computer.

- 5 Click the desired service.
- 6 The Samsung Scan Manager for the selected service opens. Adjust the scan settings. You can use the **Help** button to get on-line help.

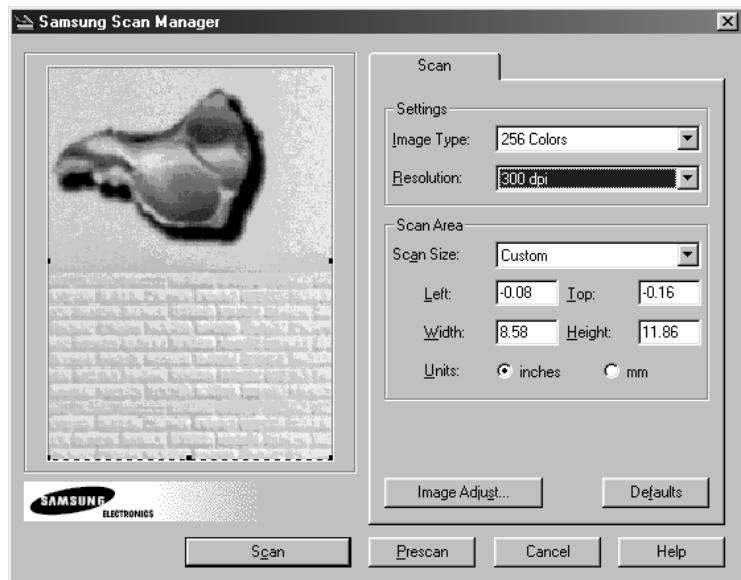

- 7 To start scanning, click **Scan**.

For further information, please refer to the SmarThru User's Guide which came with your product.



NOTE: If you want to cancel the scan job, press **Cancel/Reset** at any time.

Scanning Process with TWAIN-enabled Software

If you want to scan documents using another software, you will have to use TWAIN-compliant software such as Adobe PhotoDeluxe or Adobe Photoshop. The first time you scan with your SCX-1150F, you will need to select it as your TWAIN source on the application you will use.

The basic scanning process involves a number of steps:

- Placing your photograph or page on the document glass.
- Opening an application (such as PhotoDeluxe or Photoshop).
- Opening the TWAIN window and setting scan options.
- Scanning and saving your scanned image.

You have to follow the program's instructions for acquiring an image. Please refer to the application user's guide.



5

FAX

This chapter includes:

- **Sending a Fax**
- **Receiving a Fax**
- **Automatic Dialling**
- **Advanced Fax**
- **Additional Features**

Sending a Fax

Preparing Documents for Faxing

Use the following guidelines to prepare your documents for faxing:

- Do not attempt to feed the following types of documents into the Automatic Document Feeder:
 - carbon-paper or carbon-backed paper
 - coated paper
 - onion skin or thin paper
 - wrinkled or creased paper
 - curled or rolled paper
 - torn paper
- Remove all staples and paper clips before feeding the document.
- Make sure any glue, ink or correction fluid on the paper is completely dry before loading the document.
- Do not load documents containing different sizes or weights of paper.

Acceptable Documents (for ADF*)

| | | Single Sheet | 2 or More Sheets |
|--|------|---|---|
| Document Size | Max. | 8.5 in. (W) x 14 in. (L) (216 mm x 356 mm) | 8.5 in. (W) x 11.7 in. (L) (216 mm x 297 mm) |
| | Min. | 5.8 in. (W) x 5.0 in. (L) (148 mm x 128 mm) | |
| Effective Scanning Width | | 8.26 in. (210 mm) | |
| Number of sheets which can be loaded at a time | | | Up to 30 |
| Thickness of document | | 0.05 mm ~ 0.07 mm 0.15 mm ~ 0.2 mm | 0.075 mm ~ 0.12 mm |
| Print Quality | | Uncoated on both sides | |

*ADF stands for Automatic Document Feeder. It allows you to stack original documents, which will be faxed or copied one by one.

Loading Document(s)

You can use the Automatic Document Feeder (ADF) or the document glass to load an original document for faxing. Your ADF can load up to 30 sheets at a time. Using the document glass, you can load one sheet at a time.

- 1 Feed the document(s) **face up**, with the top edge leading into the ADF. Adjust the document guides to the width of the document. Then gently feed it in until "DOCUMENT READY" appears in the display.

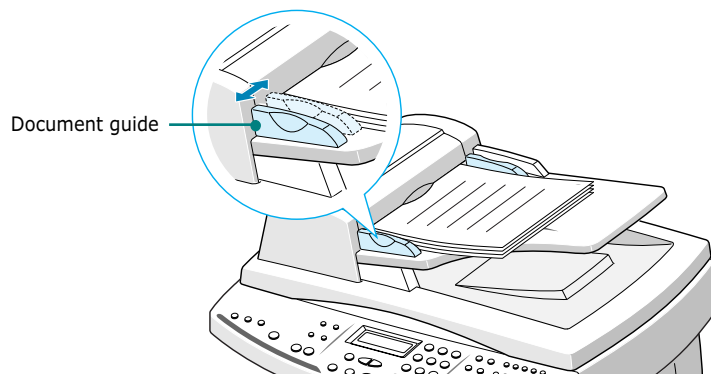

Or

Place a single document on the document glass **face down** then close the cover.

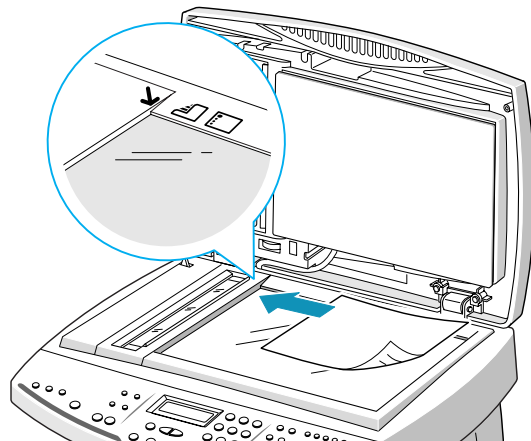

- 2 If necessary, use the **Resolution** and the **Contrast** buttons to adjust the quality of your faxes. For details, see page 5.4.

Adjusting Quality of Your Fax

When setting typical text based documents, your product enables you to send documents that are very close to the quality of the original.

However, if you send documents that are of poor quality, or contain photographs, you can adjust the following features to best suit the document.



NOTE: After you adjust the resolution or the contrast, if no key is pressed for 2 minutes or if you press **Cancel/Reset**, the settings are automatically reset to their default status (see page 5.6).

Setting Resolution

Resolution is a measure of the fineness or clarity of a printout. Low resolutions may cause text and graphics to have a jagged appearance, while higher resolutions provide smoother curves and lines, crisp text and graphics, and a better match to traditional typeface designs.

- 1** Press **Resolution** on the operation panel to select the resolution setting. The default setting appears on the bottom line of the display.
- 2** To change the setting, press **Resolution** or use the **Scroll** buttons (◀ or ▶). You can choose between **STANDARD**, **FINE**, and **SUPERFINE**. Press **Enter** to save the selection.

The document types recommended for quality settings are described below.

STANDARD works well for normal handwritten typed, or printed documents.

FINE is good for documents containing a lot of detail.

SUPERFINE works well for documents containing extremely fine detail. Superfine works only if the remote machine also has the **SUPERFINE** feature.



NOTES:

- The SUPERFINE resolution is not activated when the document is required to pre-scan into memory before sending, for example, when the **SEND FROM MEMORY** feature is set to ON (see page 5.42) or when you use the advanced faxing (see page 5.28). The SUPERFINE resolution is automatically converted to the FINE resolution when the document is scanned into memory.
- If the product is set to the SUPERFINE resolution and the remote fax machine does not support the SUPERFINE resolution, your product will transmit using the highest resolution mode supported by the remote fax machine.

Setting Contrast

Contrast is the difference in brightness between the lightest and darkest parts of a printed document. You can adjust the contrast your product will use to send faxes. Adjust according to how light or dark your document is.

- 1** Press **Contrast** on the operation panel to select the contrast setting. The default setting appears on the bottom line of the display.
- 2** To change the setting, press **Contrast** or use the **Scroll** buttons (◀ or ▶). Press **Enter** to save the selection.

You can choose between LIGHTEN, PHOTO, DARKEN, or NORMAL.

LIGHTEN works well with dark print.

PHOTO is used when faxing photographs or other documents containing shades of grey.

DARKEN works well with light print or faint pencil markings. The light image and text on the original document will be darker on the printed page.

NORMAL works well with standard typed or printed documents.

Setting Default Resolution and Contrast

You can set the default contrast and resolution for outgoing faxes. The default setting is normally applied to items being faxed.

If you want to use other Resolution and Contrast settings, you can only change the resolution and contrast for the fax job you are currently sending by pressing the **Resolution** or the **Contrast** button on the operation panel.

- 1** Press **Setup**. The display shows "1.SYSTEM SETUP" on the bottom line.
- 2** Press **Enter**.
- 3** Press the **Scroll** buttons (◀ or ▶) until you see "SET DEFAULT" on the bottom line and then press **Enter**. The first default setting menu "CONTRAST" appears on the bottom line.
- 4** Press **Enter**. The current setting displays on the bottom line.
- 5** Press the **Scroll** buttons (◀ or ▶) to select the setting you want to use as default and then press **Enter**.
- 6** Press the **Scroll** buttons (◀ or ▶) until you see "RESOLUTION" on the bottom line and then press **Enter**. The current setting displays on the bottom line.
- 7** Press the **Scroll** buttons (◀ or ▶) to select the setting you want to use as default.
- 8** Press **Enter** to save the selection.
- 9** To return to Standby mode, press **Cancel/Reset**.



NOTE: Quality, Copy Page, Zoom Rate settings are not applied to the Fax mode. These settings are available for the Copy mode only.

Sending a Fax Automatically

- 1 Feed the document(s) to be faxed **face up** into the ADF until "DOCUMENT READY" appears in the display.

Or

Place a single document on the document glass **face down** then close the cover. For details on loading original documents, see page page 3.3.

- 2 You can adjust the resolution and the contrast to suit your fax needs. For details, see "Adjusting Quality of Your Fax" on page page 5.4.

- 3 Enter the number of the remote fax machine using the number keypad.

If you make a mistake while entering a number, move the cursor under the wrong digit by using the **Scroll** buttons (◀ or ▶), and correct the number or press **Search/Delete** to delete the number.

- 4 To send faxes in black and white, press **Start FAX Black**.

To send faxes in colour to the fax machines with colour capability, press **Start FAX Color**.

- 5 If the SEND FROM MEMORY feature is set to ON (default setting), the document is scanned into memory and the display shows the memory capacity and the number of pages being stored in memory.

If the document is fed from the document glass, the display shows "NEXT GO ON?" on the top line after the document is scanned into the memory. If you have the next page, remove the scanned page and load the next page on the glass and press **Enter**. Repeat as necessary.

When all pages are scanned, press **Cancel/Reset** when the display shows "NEXT GO ON?."

- 6 The number is dialled then begins transmission when the remote fax machine is ready.



NOTE: If you want to cancel the fax, press **Cancel/Reset** at any time during the transmission.

Confirming a Transmission

When the last document has been sent successfully, the product beeps and returns to Standby mode.

If something went wrong during your fax transmission, an error message appears on the display. For a listing of error messages and their meanings, see page 7.7. When you receive an error message, press **Cancel/Reset** to clear the message and resend the document.

You can print out a confirmation report automatically each time sending is completed. For more information, see "Fax Setup Options" on page 5.41.

Automatic Redial

When you send a fax in black and white, if the number you have dialled is busy or there is no answer, the product will automatically redial the number every three minutes up to a maximum of five times. Automatic redial is not available for colour fax.

This display shows "RETRY REDIAL?." To redial the number without waiting, press **Enter**. To cancel the automatic redial, press **Cancel/Reset**.

Sending a Fax Manually

Manual sending allows you to talk to the other party before sending the document. This method is useful if the other party must manually set their fax machine to receive before they can receive a fax. For this mode, you need to have a telephone connected to your product (see page page 1.8).

- 1 Feed the document(s) to be faxed **face up** into the ADF until "DOCUMENT READY" appears in the display.

Or

Place a single document on the document glass **face down** then close the cover. For details on loading original document(s), see page page 3.3.

- 2 You can adjust the resolution and the contrast to suit your fax needs. For details, see page page 5.4.

- 3 Make a call to the remote fax machine from the extension telephone connected to your SCX-1150F.

- 4 When you hear the other party answers the call, start talking.

When you hear the high-pitched fax signal of the other party's fax machine, press **Start FAX Black** for black and white faxing or **Start FAX Color** for colour faxing.

Hang up the telephone.



NOTES:

- If you want to cancel the fax, press **Cancel/Reset** at any time during the transmission.
 - You can use the **OHD** button on the operation panel to engage the telephone line and dial the number of the remote fax machine. When you hear the fax signal, press **Start FAX Black** or **Start FAX Color** to start sending. If you pressed the **OHD** button, you will hear the other party's voice but you will not be able to talk even by using the extension telephone connected to your product.
-

Redial

The memory in your product retains the last 10 numbers called, and the last 30 numbers received, provided the CLI (Caller Line Identification) service is available.



NOTE: The CLI service may be unavailable depending on your area or country.

To redial the number last called:

- 1 Press **Redial/Pause** with a document loaded in the ADF or on the document glass. The display shows the last number dialed and prompts you to "PRESS FAX BLACK OR COLOR."
- 2 Press **Start FAX Black** for black and white faxing or **Start FAX Color** for colour faxing. Your product begins to send the number last called.

To view and dial any of the last numbers called:

- 1 Press and hold **Redial/Pause** for about 2 seconds. The display shows "REDIAL" on the bottom line.
- 2 Press **Enter**. The display shows the last number you called.
- 3 Press the **Scroll** buttons (◀ or ▶) to search through the memory until you see the number you want to dial.

If you have dialled the same number multiple times, the product does not count the duplicates.

- 4 When the number appears on the display, press **Start FAX Black** for black and white faxing or **Start FAX Color** for colour faxing.

To view and dial any of the last numbers you received:

- 1** Press and hold **Redial/Pause** for 2 seconds. The display shows "REDIAL" on the bottom line.
- 2** Press **Enter**.
- 3** Press the **Scroll** buttons (◀ or ▶) to select "CALLER ID" and then press **Enter**.
- 4** Press the **Scroll** buttons (◀ or ▶) to search through the memory until you see the number you want to dial.
- 5** When the number appears on the display, press **Start FAX Black** for black and white faxing or **Start FAX Color** for colour faxing.

Using Toll Save Transmission



If you have set a specific toll save time using the **FAX SETUP** menu (see page page 5.41), you can quickly set your document(s) to be sent at the preset time using the **SAVE Toll** button on the operation panel. Using this feature, you can take advantage of lower long distance rates at night, for example.

- 1** Feed the document(s) to be faxed **face up** into the ADF until "DOCUMENT READY" appears in the display.

Or

Place a single document on the document glass **face down** then close the cover. For details on loading original document(s), see page page 3.3.

- 2** You can adjust the resolution and the contrast to suit your fax needs. For details, see page page 5.4.

3 Press **SAVE Toll**. The display prompts you to enter the fax number.

4 Enter the number of the remote fax machine using the number keypad.

You can also use a one-touch dial button or press **Speed** then use a 2-digit speed dial number.

5 When the number appears correctly, press **Enter**. The display asks you to enter another fax number to send the document.

6 If you want to send to more than one location, select "1:YES" and enter another fax number using the number keypad.

7 When the number appears correctly on display, press **Enter**.

Or

To send to one location or when you complete the last fax number setting, select "2:NO" in the ANOTHER FAX NO.? screen.

8 The document is scanned into memory.

If the document is fed from the document glass, the display shows "NEXT GO ON?" on the top line after the document is scanned into the memory. If you have the next page, remove the scanned page and load the next page on the glass and press **Enter**. Repeat as necessary.

When all pages are scanned, press **Cancel/Reset** when the display shows "NEXT GO ON?." The display shows a reminder that a toll save transmission is reserved at the preset time.

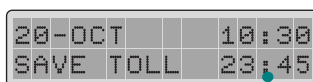

Transmission will start at 11:45 PM.



NOTE: To cancel the job reserved in memory, see "Cancelling a Scheduled Operation" on page 5.38.

Receiving a Fax



NOTE: If you installed a photo cartridge in your product, the received faxes will not print out. The display shows "MEMORY RECEIVED" and "LOAD BLACK INK" alternatively. Replace the photo cartridge with a black cartridge for receiving faxes.

About Reception Modes

Your product has four reception modes:

- In **FAX** mode, the product answers an incoming call and immediately goes into receive mode.
- In **ANS/FAX** mode, the answering machine answers an incoming call, and the caller can leave a message on the answering machine. If the product senses a fax tone on the line, the call automatically switches to the product.



NOTE: To use the ANS/FAX mode, attach an answering machine to the **EXT** jack on the back of your product (see page page 1.8).

- In **TEL** mode, the automatic fax reception is turned off. You can receive a fax by picking up the handset of the extension phone and pressing * **9** * on the phone.

You can also set the product to receive a fax by pressing **OHD** then any of the **Start FAX** button on the operation panel.



NOTE: To use the TEL mode, connect an extension phone to the **EXT** jack on the back of the product.

- In **DRPD** mode, you can receive a call using the Distinctive Ring Pattern Detection (DRPD) feature. "Distinctive Ring" is a telephone company service which enables a user to use a single telephone line to answer several different telephone numbers. This mode is displayed when you have set up the distinctive ring pattern. For details on this feature, see page page 5.44.

The current reception mode is displayed when your product is in Standby mode.



If you seldom use the fax line for voice conversations, set your product to receive a fax automatically by selecting the FAX mode.

Loading Paper for Receiving Faxes

The instructions for loading paper in the paper bin are the same whether you are printing, faxing, or copying, except that faxes can only be printed on letter-, A4-, or legal-sized paper. See "Loading Paper" on page page 1.11 for instructions.

After loading paper for receiving faxes, set the paper size to the size of paper you normally load in the paper bin. Your product uses this setting when printing reports and determining auto reduction for incoming faxes. See page page 5.42 to set the paper size.



NOTE: The **FAX PAPER SIZE** setting does not affect the printing from PC. If you are loading special-sized media only for your current print job, do not change this setting. After you have finished printing, just reload the original paper for fax printing.

Receiving Automatically in FAX Mode

Your product is preset to FAX mode at the factory. If you have changed the fax mode, take the following steps to receive faxes automatically:

- 1** Press **Receive Mode** until you see "FAX" on the bottom line. Then press **Enter**.
- 2** When you receive a call, the product answers the call on a specified number of rings and receives a fax automatically. To change the number of rings. See "Fax Setup Options" on page 5.41.

To adjust the ringer volume, see "Setting Sounds" on page 1.41.



Receiving Automatically in ANS/FAX Mode

For this mode, you must attach an answering machine to the **EXT** jack on the back of your product (see page 1.8).

- 1** Press **Receive Mode** until you see "ANS/FAX" on the bottom line. Then press **Enter**.
- 2** When you receive a call, the answering machine will answer.

If the caller leaves a message, the answering machine stores the message as it would normally. If your product hears a fax tone on the line, it automatically starts to receive fax.



NOTES:

- If you have set your product to ANS/FAX mode and your answering machine is switched off, or no answering machine is connected to your product, your product will automatically go into FAX mode after 10 rings.
 - If your answering machine has a 'user-selectable ring counter', set your product to answer incoming calls within 1 ring.
 - If you are in TEL mode (manual reception) when the answering machine is connected to your product, you must switch off the answering machine, or the outgoing message from the answering machine will interrupt your phone conversation.
-

Receiving Manually in TEL Mode Using an Extension Phone

If you are using the external telephone connected to the EXT jack on your product, you can answer calls and start the product to receive a fax.

- 1** Press **Receive Mode** until you see "TEL" on the bottom line. Then press **Enter**.
- 2** When the telephone rings, answer it by picking up the handset of the external phone.
- 3** If you hear a fax tone, or if the person on the other end asks you to receive a fax, press the keys "*** 9 ***" (star nine star) on the extension telephone.

If you still hear the fax tone from the remote machine, try pressing "*** 9 ***" once again.

"*** 9 ***" is the remote receive start code preset at the factory. The first and the last asterisks are fixed, but you can change the middle number to whatever you choose. For more information, see page 5.44.

- 4** When the product starts receiving the document, replace the handset of the extension telephone.

Receiving Using DRPD Feature

You can not set **DRPD** (Distinctive Ring Pattern Detection) as the receive mode using the **Receive Mode** button on the operation panel if you have not set up your product for use with the DRPD service and turned on the feature (see page page 5.44).

When the receive mode is set to **DRPD**, if someone calls using the number assigned for telephone communication, your product rings in the pattern you registered for voice calls. When you hear this pattern, simply pick up the handset of the extension telephone connected to your product and talk.

When someone sends a fax using the number assigned for fax communication, your product receives the fax automatically.

You can select the other receive mode using the **Receive Mode** button on the operation panel to temporarily disable the DRPD service.

Receiving in Colour

Your product has been set to receive faxes in colour from fax machines with colour capability. When receiving a fax, your product detects if the incoming fax is in colour or black & white, and prints the fax accordingly.

5

Receiving Fax in Memory

Since your product is a multitasking device, it can receive faxes while you are making copies or printing. If you receive a fax while you are copying or printing, your product stores the incoming fax in memory. Then, as soon as you finish copying or printing, the product automatically prints the fax.

If the product encounters a problem when it is receiving a fax, the product also stores the unprinted pages of the fax in memory.

Using Fax Forwarding

You can set your product to forward incoming faxes to another fax number during a specified time period. When the fax arrives at your product, it is stored in memory. Then, your product dials the fax number you have specified and sends the fax.

If it cannot forward a fax after repeated attempts because of an error, such as the number being busy and redials failed, your product will print the fax. If it runs out of memory while receiving a fax, it will terminate the incoming fax and only forward the partial pages already stored in memory.

You can also select the fax forwarding option which allows you to print the fax on your product if fax forwarding is completed without an error.

To use fax forwarding, take the following steps:

- 1** Press **FAX Forward**.
- 2** Select the fax forwarding option by pressing **FAX Forward** or the **Scroll** buttons (◀ or ▶). The following options are available:
 - FORWARD:** forwards the fax to a specified number. Your product does not print the fax.
 - FORWARD&PRINT:** forwards the fax to a specified number and prints the fax on your product.
 - OFF:** turns the fax forwarding off.
- 3** Press **Enter** to save the selection.
- 4** If you choose to forward faxes, enter the fax number where you would like the fax to go, and then press **Enter** to save your selection.
- 5** Enter the date using the number keypad you want to start forwarding incoming faxes and then press **Enter**.

- 6** Enter the time using the number keypad you want to start forwarding incoming faxes and then press **Enter**.
- 7** Enter the date using the number keypad you want to end forwarding incoming faxes and then press **Enter**.
- 8** Enter the time using the number keypad you want to end forwarding incoming faxes and then press **Enter**.
- 9** The display shows "FW" at the left side of the receiving mode, for example "FW FAX", at the bottom right corner to indicate that fax forwarding feature is activated.

When the time you have set to start forwarding is up, the display shows "FORWARDING." After the forwarding is completed, the sending confirmation report prints out automatically.



NOTE: If the fax is received in color, the product converts color fax to black&white and forwards the converted black&white fax to a specified destination.

Automatic Dialling

One-touch Dialling

One-touch dialling lets you use any of the 10 one-touch buttons to automatically dial a number.

Storing a Number for One-touch Dialling

- 1** Press and hold one of ten one-touch buttons for about 2 seconds. The display shows "Txx:," where **xx** represents the selected one-touch button number.

If a number is already stored in the location you chose, the display shows the number. To replace the number with other phone number, select "1:RENEW". Otherwise, select "2:OTHER" to select other one-touch dial location.

- 2** Enter the number you want to store by using the number keypad and then press **Enter**.

To insert a pause between numbers, press **Redial/Pause**. "P" appears on the display.

If you make a mistake while entering a number, press **Search/Delete** and re-enter the correct number.

- 3** To assign a name to the number, enter the desired name. For information on how to enter names, see "How To Enter Characters Using the Number Keypad" on page page 1.37.

Or,

If you do not want to assign a name, skip this step.

- 4** Press **Enter** when the name appears correctly or simply without entering a name.

- 5** To store more telephone numbers, press another one-touch button and repeat steps 2 through 4.

Or

To return to Standby mode, press **Cancel/Reset**.

Sending a Fax using a One-touch Number

- 1** Feed the document(s) to be faxed **face up** into the ADF until "DOCUMENT READY" appears in the display.

Or

Place a single document on the document glass **face down** then close the cover. For details on loading original document(s), see page page 3.3.

- 2** You can adjust the resolution and the contrast to suit your fax needs. For details, see page page 5.4.
- 3** Press the one-touch button where you stored a number on the operation panel. The display shows "PRESS FAX BLACK OR COLOR" then the fax number stored in the one-touch dial location alternatively.
- 4** Press **Start FAX Black** for black and white faxing or **Start FAX Color** for colour faxing.



Speed Dialling

You can store up to 90 numbers in 2-digit Speed Dial locations (01-90).

Storing a Number for Speed Dialling

- 1** Press and hold **Speed** on the operation panel for 2 seconds.
- 2** Enter a speed dial number using the number keypad and then press **Enter**.

If a number is already stored in the location you chose, the display shows the number. To replace the number with another phone number, select "1:RENEW." Otherwise, select "2:OTHER" to select another speed dial location.

- 3** Enter the number you want to store, and press **Enter**.
- 4** To assign a name to the number, enter the desired name. For details on how to enter names, see "How To Enter Characters Using the Number Keypad" on page page 1.37.

Or

If you do not want to assign a name, skip this step.

- 5** Press **Enter** when the name appears correctly or simply without entering a name.
- 6** To store more telephone numbers, repeat steps 2 through 5.

Or

To return to Standby mode, press **Cancel/Reset**.

Sending a Fax using a Speed Number

- 1** Feed the document(s) to be faxed **face up** into the ADF until "DOCUMENT READY" appears in the display.

Or

Place a single document on the document glass **face down** then close the cover. For details on loading original document(s), see page page 3.3.

- 2** You can adjust the resolution and the contrast to suit your fax needs. For details, see page page 5.4.

- 3** Press **Speed** on the operation panel.

- 4** Enter the speed dial number using the number keypad.

You can scroll through the numbers stored in memory by pressing the **Scroll** buttons (◀ or ▶).

- 5** When the desired number appears in the display, press **Enter**. The display shows "PRESS FAX BLACK OR COLOR."

- 6** Press **Start FAX Black** for black and white faxing or **Start FAX Color** for colour faxing.



Group Dialling

If you frequently send the same document to several destinations, you can create a group of these destinations and set them under a one-touch button. This enables you to press a single one-touch button to send the same document to all the destinations in the group.



NOTE: You can only group numbers that have already been registered for speed dialling.

Setting Group Dial

- 1 Press **Setup**. The display shows "1.SYSTEM SETUP" on the bottom line.
- 2 Press the **Scroll** buttons (◀ or ▶) until you see "6.GROUP SETUP" and then press **Enter**. The display prompts you to select a one-touch button.
- 3 Press the one-touch button under which you want to register the group and then press **Enter**.



NOTE: If the one-touch button has already been registered for one-touch dialling or another group, the display prompts you to renew the selected one-touch button or select another one-touch button. Select "1:RENEW" to delete the contents in the selected one-touch button and continue, or "2:OTHER" to keep the contents and start over with a different one-touch button.

- 4 The selected group number appears in the display and the display prompts you to confirm the number. Press **Enter** to accept "1:YES." If you select "2:NO", the selected one-touch button will be cancelled and you can start over with another one-touch group number.
- 5 The display prompts you to enter a speed dial number. Enter the 2-digit speed dial number you want to include in the group and then press **Enter**.

- 6 Repeat step 5 to enter another speed dial number into the group.
- 7 When you have entered all the desired numbers, press **Cancel/Reset**. The display prompts you to enter a name.
- 8 If you want to assign a name to the group, enter the desired name. Or, skip this step.
- 9 Press **Enter** after you enter the name or without entering the name.
- 10 If you want to assign another group, repeat from step 3.

To return to Standby mode, press **Cancel/Reset**.

Sending a Fax Using Group Dialling (Multi-Address Transmission)

You can use Group Dialling for broadcasting, delayed fax, priority fax, or toll save transmission.

Follow the procedure of the desired operation (Broadcasting - page page 5.28, Delayed Fax - page page 5.30, Toll Save transmission - page page 5.11). When you come to a step in which the display requests you to enter the remote fax number, press the one-touch button assigned to a group. You can use only one group number for one operation. Then continue the procedure to complete the desired operation.

Your product automatically scans the document loaded in the ADF or the document glass into the memory, and the product will dial each of the numbers included in the Group.



NOTE: If you use group dialling, only black and white faxing is available.

Searching for a Number in the Memory

There are two ways to search for a number in the memory. You can either scan from A to Z sequentially, or you can search using the first letter of the name associated with the number.

Searching Sequentially through the Memory

- 1 Press **Search/Delete** on the operation.
- 2 Press the **Scroll** buttons (◀ or ▶) to scroll through the memory until you find the name and number you want.

Pressing the **Scroll** buttons (◀ or ▶) allows you to search downward through the entire memory in alphabetical order (from A to Z).

While searching through the product's memory, you will see that each entry is preceded by one of three letters: **T** for one-touch dial, **S** for speed, or **G** for group dial number. These letters tell you how the number is stored.

- 3 When the name and number you want appears on the display, press **Enter**. The display shows "PRESS FAX BLACK OR COLOR."
- 4 Press **Start FAX Black** for black and white faxing or **Start FAX Color** for colour faxing.

Searching with a Particular First Letter

- 1** Press **Search/Delete**, then press the button labelled with the letter you want to search for. A name beginning with the letter appears on the display.

For example, if you want to find the name **MOBILE**, press the **6** button, which is labelled with **MNO**.

- 2** Press the **Scroll** buttons (◀ or ▶) to display the next name in the list.
- 3** When the name and number you want appear, press **Enter**. The display shows "PRESS FAX BLACK OR COLOR."
- 4** Press **Start FAX Black** for black and white faxing or **Start FAX Color** for colour faxing.



Advanced Fax



NOTES:

- You cannot use a colour fax for all advanced fax features.
 - When you select resolution for advanced faxes, do not select SUPERFINE resolution. Even though you select SUPERFINE, the documents will be sent with the FINE resolution.
-

Broadcasting

Documents are automatically stored in memory in the black and white mode and sent to a remote station. Use this feature to send your documents to multiple locations. After sending, the documents are automatically erased from the memory.

- 1** Feed the document(s) to be faxed **face up** into the ADF until "DOCUMENT READY" appears in the display.

Or

Place a single document on the document glass **face down** then close the cover. For details on loading original document(s), see page page 3.3.

- 2** You can adjust the resolution and the contrast to suit your fax needs. For details, see page page 5.4.
- 3** Press **Setup**. The display shows "1.SYSTEM SETUP" on the bottom line.
- 4** Press the **Scroll** buttons (◀ or ▶) until you see "4.ADVANCED FAX" and then press **Enter**. The display shows the first advanced fax feature "BROADCASTING" on the bottom line.
- 5** Press **Enter** to access the BROADCASTING menu.

- 6 Enter the number of the remote fax machine using the number keypad.

You can also press a one-touch button including group dial buttons, or press **Speed**, and enter a 2-digit speed dial number. The stored number appears on the display.

- 7 Press **Enter** to confirm the number. The display asks you to enter another fax number to send the document.

- 8 Select "1:YES" and enter another fax number using the number keypad.

You can also press a one-touch button, or press **Speed** and enter a speed dial number. Note that you cannot use Group dial numbers for another fax number.

- 9 The number appears on the display. Press **Enter** to confirm the number.

Or

To send to one location or when you complete the last fax number setting, select "2:NO" in the ANOTHER FAX NO.? screen.

- 10 The document will be scanned into the memory before transmission. The display shows the memory capacity and the number of pages being stored in the memory.

If the document is fed from the document glass, the display shows "NEXT GO ON?" on the top line after the document is scanned into the memory. If you have the next page, remove the scanned page and load the next page on the glass and press **Enter**. Repeat as necessary.

When all pages are scanned, press **Cancel/Reset** when the display shows "NEXT GO ON?"

- 11 The product begins sending the document in order of the numbers you entered.

Delayed Fax

You can set your product to send a fax at a later time when you will not be present.



NOTE: You cannot use the colour fax for the delayed faxing.

- 1** Feed the document(s) to be faxed **face up** into the ADF until "DOCUMENT READY" appears in the display.

Or

Place a single document on the document glass **face down** then close the cover. For details on loading original document(s), see page page 3.3.

- 2** You can adjust the resolution and the contrast to suit your fax needs. For details, see page page 5.4.

- 3** Press **Setup**. The display shows "1.SYSTEM SETUP" on the bottom line.

- 4** Press the **Scroll** buttons (◀ or ▶) until you see "4.ADVANCED FAX" and then press **Enter**. The display shows the first advanced fax feature "BROADCASTING" on the bottom line.

- 5** Press the **Scroll** buttons (◀ or ▶) until you see "DELAYED FAX" on the bottom line and then press **Enter**.

- 6** Enter the number of the remote fax machine using the number keypad.

You can also press a one-touch button including group dial buttons, or press **Speed**, and enter a 2-digit speed dial number. The stored number appears on the display.

- 7** Press **Enter** to confirm the number. The display asks you to enter another fax number to send the document.

- 8** If you want to send to more than one location, select "1:YES", and enter another fax number using the number keypad.

You can also press a one-touch button, or press **Speed** and enter a speed dial number. Note that you cannot use Group dial numbers for another fax number.

- 9** The number appears on the display. Press **Enter** to confirm the number.

Or

To send to one location or when you complete the last fax number setting, select "2:NO" in the ANOTHER FAX NO.? screen.

- 10** The display asks you to enter a name. If you want to assign a name to the transmission, enter the name. If not, skip over this step.

For details on how to enter the name using the number keypad, see "How To Enter Characters Using the Number Keypad" on page 1.37.

- 11** Press **Enter**. The display shows the current time and asks you to enter the start time when the fax is to be sent.

- 12** Enter the time by using the number keypad.

To select AM or PM for 12-hour format, press the **Scroll** buttons (◀ or ▶). If you set a time earlier than the current time, the document will be sent at that time on the following day.

- 13** Press **Enter** when the start time on the display is correct.

The document will be scanned into the memory in the black and white mode before transmission.

The display shows the memory capacity and the number of pages being stored in the memory.



14 If the document is fed from the document glass, the display shows "NEXT GO ON?" on the top line after the document is scanned into the memory. If you have the next page, remove the scanned page and load the next page on the glass and press **Enter**. Repeat as necessary.

When all pages are scanned, press **Cancel/Reset** when the display shows "NEXT GO ON?."

The product returns to Standby mode and the display reminds you that you are in Standby mode and that Delayed Transmission is set.



NOTE: If you want to cancel the Delayed Fax, see "Cancelling a Scheduled Operation" on page 5.38.

Priority Fax

When the Priority Send is enabled, a high priority document can be transmitted ahead of reserved operations. The document is scanned into the memory, then transmitted when the current operation is concluded. In addition, the Priority Send will interrupt a broadcast operation between stations (i.e., when transmission to station A ends, before transmission to station B begins) or between redial attempts.



NOTE: You cannot use the colour fax for the priority faxing.

- 1 Feed the document(s) to be faxed **face up** into the ADF until "DOCUMENT READY" appears in the display.

Or

Place a single document on the document glass **face down** then close the cover. For details on loading original document(s), see page page 3.3.

- 2 You can adjust the resolution and the contrast to suit your fax needs. For details, see page page 5.4.

- 3 Press **Setup**. The display shows "1.SYSTEM SETUP" on the bottom line.

- 4 Press the **Scroll** buttons (◀ or ▶) until you see "4.ADVANCED FAX" and then press **Enter**. The display shows the first advanced fax feature "BROADCASTING" on the bottom line.

- 5 Press the **Scroll** buttons (◀ or ▶) until you see "PRIORITY FAX" on the bottom line and then press **Enter**.

- 6 Enter the number of the remote fax machine using the number keypad.

You can also press a one-touch button, or press **Speed**, enter a 2-digit speed dial number. The stored number appears on the display.



NOTE: You cannot use group dial numbers for the priority faxing.

- 7 Press **Enter** to confirm the number. The display asks you to enter a name.

- 8 If you want to assign a name to the transmission, enter the name. If not, skip over this step.

For details on how to enter a name using the number keypad, see "How To Enter Characters Using the Number Keypad" on page page 1.37.

- 9 Press **Enter**. The document will be scanned into the memory before transmission.

The display shows the memory capacity and the number of pages being stored in the memory in the black and white mode.

If the document is fed from the document glass, the display shows "NEXT GO ON?" on the top line after the document is scanned into the memory. If you have the next page, remove the scanned page and load the next page on the glass and press **Enter**. Repeat as necessary.

When all pages are scanned, press **Cancel/Reset** when the display shows "NEXT GO ON?."

- 10 The product shows the number being dialled and then begins sending the document.

Polling

Polling is used when one fax machine requests another to send a document. This is useful when the person with the original document to be sent is not in the office. The person who wants to receive the document calls the machine holding the original and requests that the document be sent. In other words, it "polls" the machine holding the original.

Polling Transmission

You can program your product to send documents in your absence when polled by a remote fax machine. It is possible to use a poll code to prevent unauthorised polling of your product. When you secure your product in this manner, only those who know the poll code can poll your product.

- 1** Feed the document(s) to be faxed **face up** into the ADF until "DOCUMENT READY" appears in the display.

Or

Place a single document on the document glass **face down** then close the cover. For details on loading original document(s), see page 3.3.

- 2** You can adjust the resolution and the contrast to suit your fax needs. For details, see page 5.4.

- 3** Press **Setup**. The display shows "1.SYSTEM SETUP" on the bottom line.

- 4** Press the **Scroll** buttons (◀ or ▶) until you see "4.ADVANCED FAX" and then press **Enter**. The display shows the first advanced fax feature "BROADCASTING" on the bottom line.

- 5** Press the **Scroll** buttons (◀ or ▶) until you find "SEND POLLING" on the bottom line and then press **Enter**.

The display asks you to enter a 4-digit poll code. The poll code is preset to 0000 at the factory, which represents no poll code.

- 6** If you want to use a poll code, enter the desired 4-digit code (except for 0000) and then press **Enter**.

Or

If you do not want to secure the transmission with a poll code, press **Enter** when the display shows "0000" for the poll code, or enter **0000**.

- 7** The product stores the document in the memory.

The display counts the number of pages being stored in the memory and the memory capacity remaining.

If the document is fed from the document glass, the display shows "NEXT GO ON?" on the top line after the document is scanned into the memory. If you have the next page, remove the scanned page and load the next page on the glass and press **Enter**. Repeat as necessary.

When all pages are scanned, press **Cancel/Reset** when the display shows "NEXT GO ON?."

- 8 The product returns to Standby mode and the display shows a reminder that TX Poll is set.



NOTE: If you have previously set the receive mode to other than FAX mode, the product automatically switches to FAX mode (automatic receiving) when set to be polled.

Polling a Remote Machine

Your product polls a remote fax machine and retrieves a document, which is stored in memory and then prints. The method lets you perform polling reception when telephone-line rates are at their lowest.

- 1 Press **OHD** and enter the number of the remote machine.
- 2 When you hear a fax tone from the remote machine, press **Setup**. The display shows "TO RX ROLL PRESS ENTER."
- 3 Press **Enter**. The display asks you to enter a 4-digit poll code. Poll code is preset to 0000 at factory. 0000 represents no code.
- 4 If the remote machine is secured with a Poll code, you must enter the correct code and then press **Enter**.

Or

If the remote machine is not secured with a Poll code, just press **Enter** to accept "0000" which represents on code.

- 5 Your product starts to receive the document from the remote machine.

Adding Documents To a Scheduled Operation

You can add documents to the delayed transmission previously reserved in your product's memory.

- 1** Feed the document(s) to be faxed **face up** into the ADF until "DOCUMENT READY" appears in the display.

Or

Place a single document on the document glass **face down** then close the cover. For details on loading original document(s), see page page 3.3.

- 2** You can adjust the resolution and the contrast to suit your fax needs. For details, see page page 5.4.

- 3** Press **Setup**. The display shows "1.SYSTEM SETUP" on the bottom line.

- 4** Press the **Scroll** buttons (◀ or ▶) until you see "4.ADVANCED FAX" and then press **Enter**. The display shows the first advanced fax feature "BROADCASTING" on the bottom line.

- 5** Press the **Scroll** buttons (◀ or ▶) until you see "ADD SCHEDULE" on the bottom line then press **Enter**.

The display shows the information of the last job reserved in the memory.

- 6** Press the **Scroll** buttons (◀ or ▶) repeatedly until you find the operation to which you want to add documents, then press **Enter**.

The product automatically stores the documents in the memory in the black and white mode, and the display shows the memory capacity and the number of pages.



If you the document is fed from the document glass, the display shows "NEXT GO ON?" on the top line after the document is scanned into the memory. If you have the next page, remove the scanned page and load the next page on the glass and press **Enter**. Repeat as necessary.

When all pages are scanned, press **Cancel/Reset** when the display shows "NEXT GO ON?."

- 7 After storing, the product displays the number of total pages, then returns to Standby mode.

Cancelling a Scheduled Operation

- 1 Press **Setup**. The display shows "1.SYSTEM SETUP" on the bottom line.
- 2 Press the **Scroll** buttons (◀ or ▶) until you see "4.ADVANCED FAX" and then press **Enter**. The display shows the first advanced fax feature "BROADCASTING" on the bottom line.
- 3 Press the **Scroll** buttons (◀ or ▶) until you see "CANCEL SCHEDULE" on the bottom line and then press **Enter**.

The display shows the information of the last job reserved in the memory.

- 4 Press the **Scroll** buttons (◀ or ▶) repeatedly until you find the operation you want to cancel and then press **Enter**. The selected job is cancelled.

Additional Features

Printing Reports

Your product can print reports containing useful information – Schedule Job, System Data, etc. The following reports are available:

Help List

This list shows the product's basic functions and commands to use as a quick reference guide.

Sent Journal

This report shows information concerning transmission activities recently made.

Received Journal

This report shows information concerning reception activities recently made.

Phonebook

This list shows all of the numbers currently stored in the product's memory as one-touch dial numbers, Speed dial numbers and Group dial numbers.

Sending Confirmation

This report shows the fax number, the number of pages, elapsed time of the operation, the communication mode, and the communication results.

You can set up your product to print the message confirmation report in one of the following ways:

- Automatically after each transmission (ON)
- Automatically only if an error occurs during transmission (ERR)
- No report printed at all (OFF). You can print this report manually at any time you want.

Schedule Information

This list shows the document currently stored for Delayed Sending, Priority Sending, Group Sending, and TX polling. The list shows the starting time, type of operation, etc.

System Data

This list shows the status of System Setup, Fax Setup, and Copy Setup options. After you change any setting, print this list to confirm your changes.

Self Test Page

This page shows the pattern indicating the status of the cartridge nozzle. You can check if the product is printing correctly using this page.

CID (Caller Identification) List

This list shows the 30 last numbers you received if you have the Caller Line Identification Service provided by the network. You can check the phone number of the caller and the date and time when the call was received.

Junk Fax List

This list shows the fax numbers defined as junk fax number by using the Junk Fax Setup menu (see page 5.46). When the Junk Fax Barrier feature is turned on, the incoming faxes from those numbers will be blocked.

Multi-Communication Report

This report is printed automatically after sending documents to more than one location.

Power Failure Report

This report is printed out automatically when power is restored after a power failure if there occurs any data loss due to the power failure.



NOTE: The list you have set to print out automatically will not print out when there is no paper loaded or a paper jam has occurred.

Printing List

- 1** Press **Setup**. The display shows "1.SYSTEM SETUP" on the bottom line.
- 2** Press the **Scroll** buttons (◀ or ▶) repeatedly until you see "5.REPORT/HELP" on the bottom line, and press **Enter**.
- 3** Press the **Scroll** buttons (◀ or ▶) repeatedly until you find the list you want to print.
- 4** When the desired list displays, press **Enter**. The selected list will be printed.

Fax Setup Options

Your product has various user-selectable setup options for the fax system. These options are preset at the factory, but you may need to change them. To find out how the options are currently set, print the System Data list. For details on printing the list, see above.



Setting an Option

- 1** Press **Setup**. The display shows "1.SYSTEM SETUP" on the bottom line.
- 2** Press the **Scroll** buttons (◀ or ▶) until you see "2.FAX SETUP" and then press **Enter**. The display shows the first option "SEND FROM MEMORY" on the bottom line.
- 3** Scroll through the options by pressing the **Scroll** buttons (◀ or ▶) repeatedly.
- 4** When the option you want appears on the display, press **Enter**. The current setting is tagged with a ◀ at the end of the display in bottom line.

- 5 Choose the desired status by pressing the **Scroll** buttons (◀ or ▶) repeatedly, and then press **Enter** to save the selection.
- 6 Repeat to set other data options if necessary.
You can exit from setup mode at any time by pressing **Cancel/Reset**.

Selectable Options

These instructions assume you've followed the steps under "Setting an Option" on page 5.41 and the product is prompting you to change one of the options listed here.

- **SEND FROM MEMORY** : If you are annoyed that you have to wait until documents in the ADF are sent out when you try to send or reserve another fax, turn this feature on. This feature enables all transmission documents to be automatically scanned into memory before transmission.

Select **ON** to turn this feature on.

Select **OFF** to turn this feature off.



NOTE: If you set this option to **ON** color faxing will be disabled.

- **SENDING CONFIRM** : A message confirmation report shows whether the transmission was successful or not, how many pages were sent, etc.

Select **ON** to print a confirmation report automatically each time you send a fax.

Select **OFF** to turn this feature off.

Select **ERROR** to print only when an error occurs and the transmission was not successful.

- **FAX PAPER SIZE** : Select the paper size you will use for the recording paper. **LETTER**, **A4**, **LEGAL** sizes are available.



NOTE: If you set the **Auto Reduction** menu option, or turned **Paper Save** mode on, your product will determine the reduction rate according to this setting.

- **AUTO REDUCTION** : When receiving a document as long or longer than the paper loaded in your product, the product can reduce the received data to fit into your recording paper size.

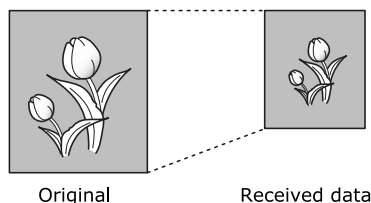

Turn this feature on to reduce an incoming page that may need to be divided into two pages with only a few lines on the second page. If the product cannot reduce the data to fit onto one page with this feature enabled, the data will be divided and printed in actual size on two or more sheets if necessary.

Select **ON** to enable. Note that this feature does not apply to the copy mode.

Select **OFF** to turn this feature off. The overflow data will be printed out on a second page.

- **SAVE TOLL TIME**: You can set the toll save time for toll save transmission using the **SAVE Toll** button. For details on toll save transmission, see page 5.11.

Enter the desired time using the number keypad. If you have set the clock mode to 12 hour mode, you can toggle between AM and PM by pressing the **Scroll** buttons (◀ or ▶) repeatedly.

- **RINGS TO ANSWER** : You can select the number of times your product rings before answering an incoming call.

Enter a number from **1** to **7** on the number keypad.

- **REDIAL INTERVAL** : Your product can automatically redial a remote fax machine if it was busy or does not answer on the first call.

Enter the number of minutes (from **1** to **15**) using the number keypad.

- **REDIAL COUNT** : Enter the number of attempts (from **0** to **9**) to redial the number.

If you enter **0**, the product will not redial.

- **STAMP RCV. NAME** : Allows the product to automatically print the page number, and the date and time of the reception at the bottom of each page of a received document.

Select **ON** to turn this feature on.

Select **OFF** to turn this feature off.

- **RCV. START CODE** : The remote receive code allows you to initiate fax reception from an extension phone plugged into the EXT jack. If you pick up the extension phone and hear fax tones, enter the remote receive code and the fax will start receiving. The password is preset to * 9 * at the factory.

Enter the desired code **0** to **9** on the number keypad.

- **DRPD (Distinctive Ring Pattern Detection) MODE** :

'Distinctive Ring' is a telephone company service which enables a user to use a single telephone line to answer several different telephone numbers. The particular number someone uses to call you on is identified by different ringing patterns, which consist of various combinations of long and short ringing sounds. This feature is often used by answering services who answer telephones for many different clients and need to know which number someone is calling in on to properly answer the phone.

Using the Distinctive Ring Pattern Detection feature, your product can 'learn' the ring pattern you designate to be answered by the SCX-1150F product. Unless you change it, this ringing pattern will continue to be recognised and answered as a FAX call, and all other ringing patterns will be forwarded to the extension telephone or answering product plugged into the EXT jack. You can easily suspend or change Distinctive Ring Pattern Detection at any time.

Before using the Distinctive Ring Pattern Detection option, Distinctive Ring service must be installed on your telephone line by the telephone company. To setup Distinctive Ring Pattern Detection, you will need another telephone line at your location, or someone available to dial your fax number from outside.

Select **ON** to turn this mode on.

Select **OFF** to turn this mode off.

Select **SET** to setup the Distinctive Ring Pattern Detection. The LCD displays "WAITING RING." Call your fax number from another telephone. It is not necessary to place the call from a product. When your product begins to ring, do not answer the call. The product requires several rings to learn the pattern.

When the product completes 'learning', the LCD displays "END DRPD SETUP."

With the DRPD feature active, "DRPD" appears in the display and the previously set reception mode is ignored. If you turn DRPD off, the product returns to any previously set reception mode.



NOTES:

- DRPD must be set up again if you re-assign your fax number, or connect the product to another telephone line.
 - After DRPD has been set up, call your fax number again to verify that the product answers with a fax tone, then have a call placed to a different number assigned to that same line to be sure the call is forwarded to the extension telephone or answering product plugged into the EXT jack.
-

- **ECM (Error Correction Mode) MODE :** This mode compensates for poor line quality and ensures accurate, error-free transmission with any other ECM-equipped facsimile machine. If the line quality is poor, transmission time may be increased when ECM is enabled.

Select **ON** to turn the Error Correction mode on.

Select **OFF** to turn this Error Correction mode off.

- **AUTO JOURNAL :** A journal shows specific information concerning transmission or reception activities, the time and dates of up to 40 most recent transmissions or receptions.

Select **ON** to print the journal automatically after every 40 transmissions or receptions.

Select **OFF** to print the journal manually.

- **CALLER ID :** When you receive a call, you can see the number of the person calling you if you have Line Identification Service provided by the network. (This option may not work when connected to a PABX.)

Select **ON** to display the caller ID.

Select **OFF** not to display the caller ID.



NOTE: The Caller ID option may be unavailable depending on your area or country.

- **JUNK FAX BARRIER** : With this feature set to **ON**, the system will not accept a fax sent from the remote station of which the fax number is stored in memory as junk fax number via the Junk Fax Setup menu below.

Select **ON** to turn this feature on. You can not receive from the registered stations.

Select **OFF** to turn this feature off. Anybody can send you a fax.

- **JUNK FAX SETUP** : You can register up to 20 fax numbers from the CID (Caller Identification) list as junk fax numbers. When the Junk Fax Barrier feature is turned on, the incoming faxes from those numbers will be blocked.

Select **REGISTER** to register a junk fax number. Press the **Scroll** buttons (◀ or ▶) to scroll through the CID list, and press **Enter** when the desired number is displayed.

Select **DELETE** to delete a registered junk fax number. Press the **Scroll** buttons (◀ or ▶) to scroll through the list and press **Enter** when the desired number is displayed.

Using the Fax Settings Utility

When you install the MFP driver, the Fax Settings Utility is automatically installed. With this program, you can configure the various fax setup options and store speed dial numbers on your computer. You can download the information to your SCX-1150F.

To install the MFP driver, see “Installing Samsung Software” on page 1.20.

Accessing the Fax Settings Utility

- 1 Click **Start** > **Programs**> **SAMSUNG SCX-1150 Series**> **Fax Settings Utility**.

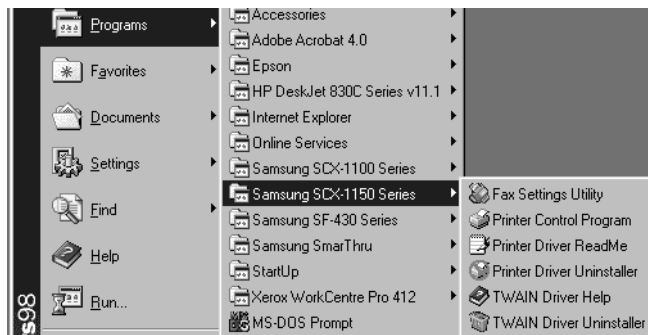

▲ In the case of Windows 98

- 2 The Samsung SCX-1150F Fax Settings Utility dialogue box opens.
- 3 After using the Fax Settings Utility, click **Exit** to close the dialogue box.

You can get online help by clicking the **Help** button.

Settings Tab

Using the **Settings** tab on the Fax Settings Utility dialogue box, you can set up the fax name and number, and configure the fax setup options. For details on each setup option, see “Fax Setup Options” on page 5.41.

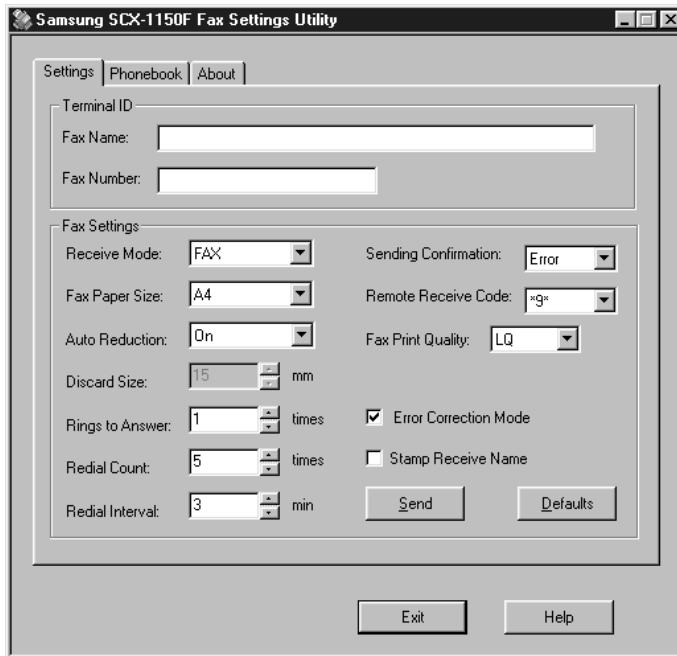

The screenshot shows the 'Samsung SCX-1150F Fax Settings Utility' dialog box with the 'Settings' tab selected. The dialog has three tabs: 'Settings', 'Phonebook', and 'About'. The 'Terminal ID' section contains two text input fields: 'Fax Name' and 'Fax Number'. The 'Fax Settings' section contains several controls: 'Receive Mode' (dropdown menu set to 'FAX'), 'Sending Confirmation' (dropdown menu set to 'Error'), 'Fax Paper Size' (dropdown menu set to 'A4'), 'Remote Receive Code' (dropdown menu set to '*9*'), 'Auto Reduction' (dropdown menu set to 'On'), 'Fax Print Quality' (dropdown menu set to 'LQ'), 'Discard Size' (spin box set to '15' mm), 'Rings to Answer' (spin box set to '1' times), 'Redial Count' (spin box set to '5' times), 'Redial Interval' (spin box set to '3' min), 'Error Correction Mode' (checked checkbox), and 'Stamp Receive Name' (unchecked checkbox). At the bottom of the 'Fax Settings' section are 'Send' and 'Defaults' buttons. At the bottom of the dialog box are 'Exit' and 'Help' buttons.

When you complete configuration, click **Send** to download the information to SCX-1150F.

The **Defaults** button allows you to restore the default status of each item.

Phonebook Tab

Using the **Phonebook** tab, you can store the speed dial numbers (for details on speed dialling, see page 5.22).

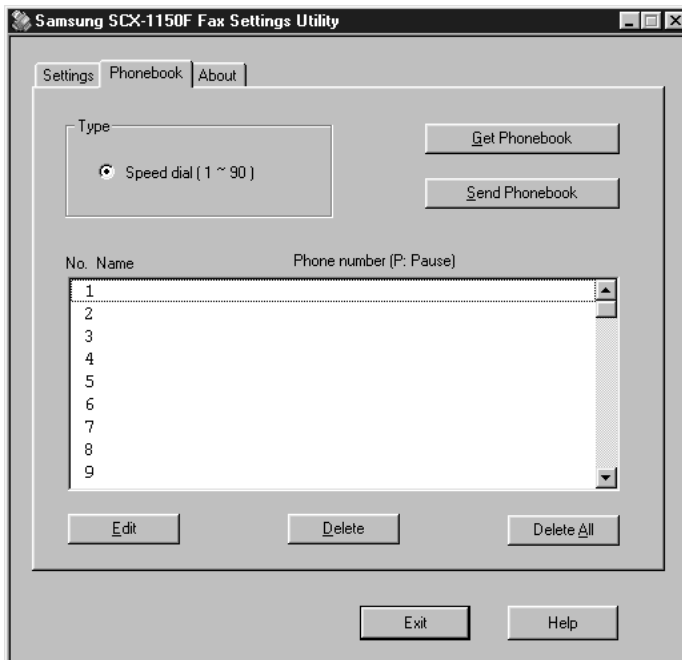

- **Get Phonebook:** gets the speed dial numbers stored in memory of your product.
- **Send Phonebook:** sends the speed dial numbers to your product. After storing a speed dial number, you must click this button to use the numbers on the operational panel your product.
- **Edit:** allows you to store or edit a speed dial number. After selecting the desired speed dial location from the list, click this button. Then, enter a name and number in the Edit - Speed dial #X dialogue box (where X designates the selected speed dial location), and click **OK** to save.
- **Delete:** deletes the selected speed dial number.
- **Delete All:** deletes all the speed dial numbers.

About Tab

The **About** tab gives you the program version number. If you click on the globe image on the bottom of the window, you will be connected to the Samsung web site provided you are the internet user.

NOTE



5.50 FAX

6

MAINTENANCE

This chapter provides suggestions for high-quality and economical printing and information for maintaining the print cartridge and your product.

This chapter includes:

- **Maintaining Print Cartridges**
- **Viewing Ink Level**
- **Cleaning Print Cartridges**
- **Replacing Print Cartridges**
- **Aligning Print Cartridges**
- **Clearing Memory**
- **Remote Test**
- **Cleaning the Document Glass**

Maintaining Print Cartridges

To get the maximum benefit from your print cartridges:

- Do not remove a print cartridge from its packaging until you are ready to install it.
- Do not refill the print cartridges. The warranty does not cover damage caused by using refilled cartridges.
- Store the print cartridges in the same environment as your product.
- Do not remove a print cartridge from the product except to replace, or clean. Immediately replace the print cartridge or store in the storage unit. The print cartridge will not print correctly if removed from the product and left exposed for an extended period of time.
- Do not swap the colour cartridge with the black cartridge. The colour cartridge should be installed in the left carrier and the black cartridge in the right carrier.
- If you have an opened ink cartridge you are not currently using and do not have an available print cartridge storage unit, store it in an airtight plastic bag. Do not leave it exposed to air for an extended period; this promotes drying out and clogging of the print nozzles.



NOTE: If any (or both) cartridge(s) is not installed in the product, the display alerts you with the message "CHECK xxxx CARTRIDGE" (where xxxx designates the empty cartridge). Install the cartridge(s) to print properly.

However, if you force to print out, your product can function even when any (or both) cartridge runs out of ink or is not installed. For example, if a fax is received when any cartridge is not installed, the display alerts with the message "CHECK xxxx CARTRIDGE" and toggles "TO FAX PRINT PRESS ENTER." If you press **Enter**, the product prints out the received fax with one (or no) cartridge installed. The print quality cannot be normal and you may see a white paper.

Viewing Ink Level

You can view the ink level on the LCD display using the operation panel buttons. Take the following steps:

- 1 Press **Setup**. The display shows "1.SYSTEM SETUP" on the bottom line.
- 2 Press the **Scroll** buttons (◀ or ▶) until you see "8.MAINTENANCE" and then press **Enter**.
- 3 Press the **Scroll** buttons (◀ or ▶) until you see "VIEW INK LEVEL" on the bottom line of the display and then press **Enter**.
- 4 The display shows the amount of ink remaining for the black (or photo) and the colour print cartridges.

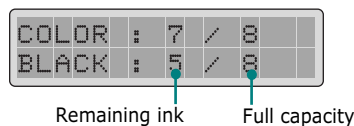

Cleaning Print Cartridges



Cleaning your print cartridges can improve the quality of printing. If your printed page is missing lines or dots or contains ink streaks, clean the print cartridges as described below.

There are two methods to clean the print cartridges:

- Print a head cleaning page, which can be done from the operation panel of your product or from the Control Program on your computer screen.
- Clean the print cartridge nozzles.



NOTE: Do not clean the print cartridges unnecessarily, as this wastes ink and shortens the life of the print cartridge.



Printing a Cleaning Page from the Product

- 1 Press **Setup**. The display shows "1.SYSTEM SETUP" on the bottom line.
- 2 Press the **Scroll** buttons (◀ or ▶) until you see "8.MAINTENANCE" and then press **Enter**.

The first maintenance option "CLEAN CARTRIDGE" appears on the bottom line of the display.

- 3 Press **Enter** to start the cleaning process. Your product prints a cartridge clean page.
- 4 Examine the cleaning pattern. Compare the diagonal lines at the top and bottom of the test pattern.

A broken line shows any clogged nozzles. If the bottom line shows improvement, rerun this cleaning process two more times.

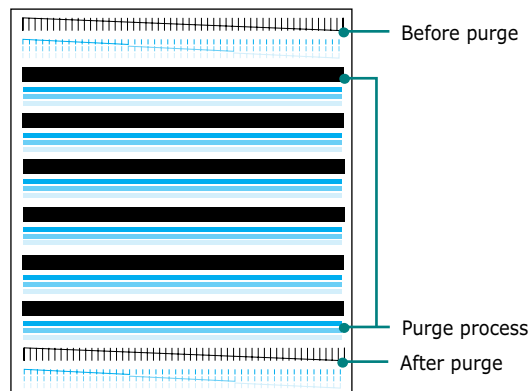

If this process does not improve the print quality, your print cartridges may be low in ink. Replace the print cartridge, if necessary.

- 5 If the line is still broken, clean the print nozzles. See "Cleaning Print Cartridge Nozzles" on page 6.6.



Printing a Cleaning Page from Your Computer

- 1 Click **Start** > **Programs** > **Samsung SCX-1150 Series** > **Printer Control Program**.
- 2 The Samsung SCX-1150 Series window appears. Select the **Cartridges** tab.



▲ In case of Windows 98

- 3 Click **Clean Print Nozzles**.
- 4 The product feeds a sheet of paper and prints a cleaning pattern. Examine the cleaning pattern. Refer to step 4 under "Printing a Cleaning Page from the Product" on page 6.4.



NOTE: In Windows 2000/XP, the Printer Control Program is unavailable. But, you can access the Cartridge Maintenance features through the printer properties by taking the following steps:

1. Click **Start** > **Settings** > **Printers**.
2. Right-click on **Samsung SCX-1150 Series** printer in the Printers folder.
3. From the pop-up list, select **Properties**.
4. Click the **Cartridge Maintenance** tab.

Cleaning Print Cartridge Nozzles

If print quality does not improve after repeatedly printing the cleaning page, the problem may be caused by dried ink on the print cartridges.

- 1 Open the cartridge door by grabbing the door handle at the top edge.

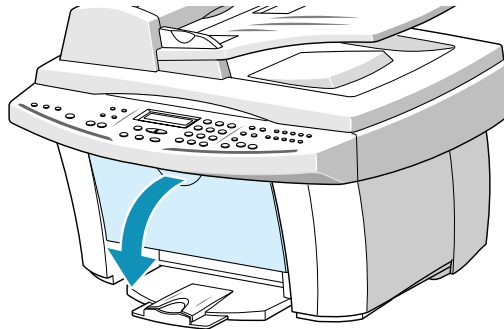

- 2 Remove the print cartridges. For details, refer to step 3 under "Replacing Print Cartridges" on page 6.12.

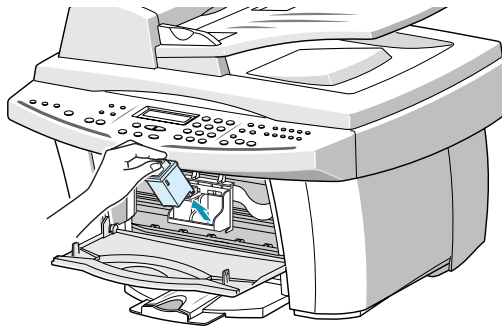

NOTES:

- Keep new and used print cartridges out of the reach of children.
 - Once you have removed the print cartridges, ensure that they are not out of the printer longer than 30 minutes.
 - Be careful not to touch the ink nozzles or the electrical contacts. Touching these parts of the print cartridge can result in clogs, ink failure, or a bad electrical connection.
-

- 3 Use a clean cloth, dampened with water only, to gently clean the entire copper coloured area, including the nozzles and contacts.

To dissolve any dried ink, place the cartridge on a heavy damp cloth as shown below and push the cartridge with light pressure to let the nozzles come in contact with the cloth for about three seconds. Then gently blot and wipe dry.

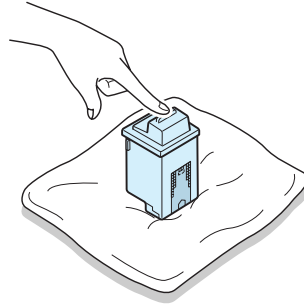

If you are cleaning a colour print cartridge, be especially careful to wipe the nozzles in only one direction so the colours do not mix.

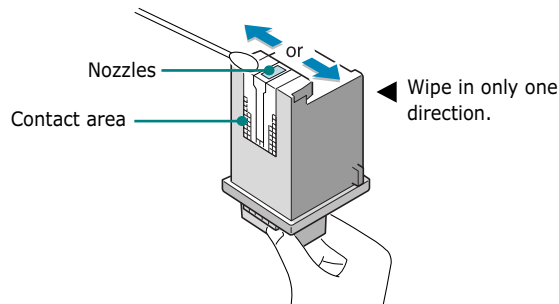

- 4 Allow the copper-coloured area to dry.
- 5 Reinstall the print cartridges and close the cartridge door. The display shows "CARTRIDGE CHANGED? NO." Press **Enter**. The display returns to Standby mode.
- 6 Print a cleaning page and examine the cleaning pattern by following the instructions on page 6.3. If the line is still broken, clean the print cartridge holder contacts in your product.



NOTE: Once the cartridges are removed and installed, cartridge alignment may be required. After you clean the cartridge, if necessary, align the cartridges.

Cleaning Cartridge Holder Contacts

- 1 Open the cartridge door by grabbing the door handle at the top edge.

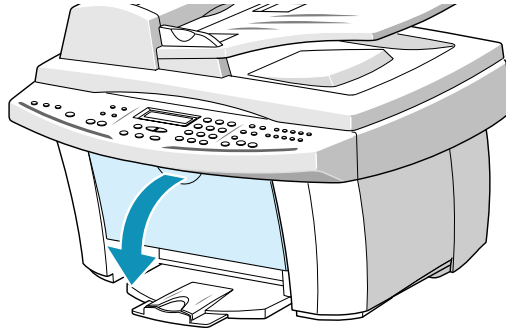

- 2 After the print cartridges have moved to the centre of the printer, unplug the power cord to turn the power off with the cartridge holder in the centre.

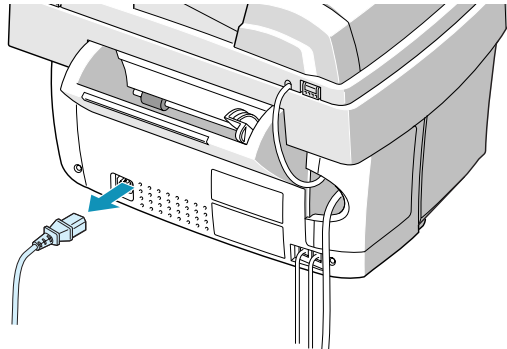

- 3 Remove the print cartridges. For details, refer to step 3 under "Replacing Print Cartridges" on page 6.12.

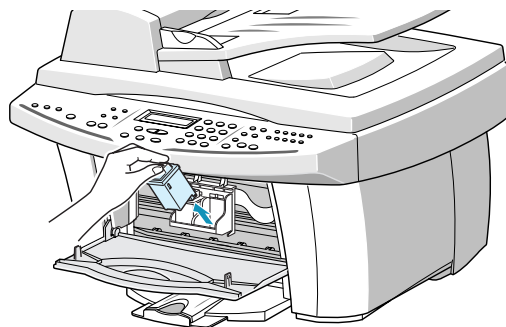

- 4 Use a **CLEAN, DRY CLOTH** to clean the print cartridge contacts inside the printer.

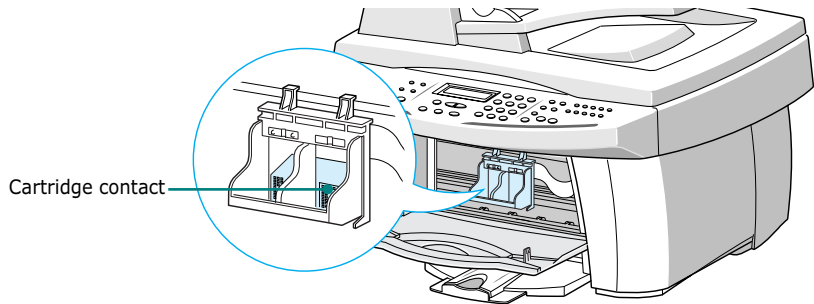

- 5 Reinstall the print cartridges, then close the cartridge door.
- 6 Plug the power cord back to the AC power outlet.

Replacing Print Cartridges

Your product is a dual cartridge inkjet printer. You must use a colour and a black (or photo) ink cartridge.

An optional photo cartridge gives excellent, near photo quality printing. When you wish to use a photo cartridge, replace the black cartridge with the photo cartridge. When you finish using the photo cartridge, immediately swap it with the black cartridge because:

- Normal incoming faxes can not be printed when the photo cartridge is installed. They will be saved to memory so you may print them later.
- Photo cartridge should be used for printing pictures.
- Printing black with the photo cartridge installed will be much slower than using the black cartridge.

6

There are two types of black and colour cartridge: Standard and High yield. Before proceeding to install, you need to check which cartridge type you have. When you install the cartridges, you will be asked if it is Standard or High Yield. To find out the type, refer to the table below.

| Cartridge type | | Part number |
|------------------|------------|------------------------------------|
| Black cartridge | High yield | Lexmark 12A1975 |
| | Standard | Samsung INK-M50 Lexmark 12A1970 |
| Colour cartridge | High yield | Lexmark 15M0125 |
| | Standard | Samsung INK-C60 Lexmark 15M0120 |
| Photo cartridge | | Lexmark 12A1990 |

When you notice the print becomes light or "CHANGE xxxx INK" (where xxxx designates the empty cartridge) appears in the display, replace the appropriate cartridge(s).

The print cartridge includes the ink supply and the print head. Each time you replace the ink cartridge you are replacing the print head as well.

Replacement of the print cartridges can be done from the operation panel of your product or from the computer using the Samsung SCX-1150 Series Control Program.



Replacing Print Cartridges from the Product

- 1 Carefully unwrap the new ink cartridge(s) and remove the sealing tape. Slowly pull straight out.

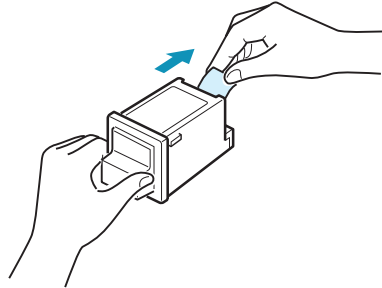

NOTE: Avoid touching the electrical contacts on the cartridge. Ensure that there are no pieces of tape remaining on the cartridge.

- 2 Open the cartridge door by grabbing the door handle on the top edge. The print cartridge carrier moves to the centre position of the product.



6

- 3 Locate the print cartridge holder inside the product. The black (or photo) ink cartridge holder is located on the right side of the cartridge holder and the colour ink cartridge is located on the left side.

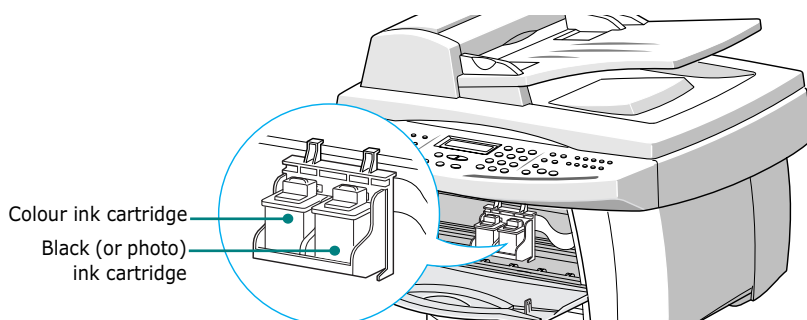

- 4 Pull the old cartridge(s) toward you until you hear a click and then remove the cartridge(s) from the holder.

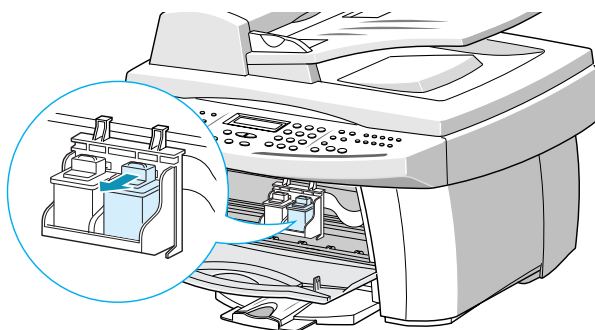

- 5 Place the new print cartridge(s) into the holder and push it until it clicks into place.
- 6 Close the cartridge door. The display prompts you to confirm the changed cartridge(s).
You can choose from NO, LEFT, RIGHT, and BOTH by using the **Scroll** buttons (◀ or ▶). Press **Enter** when your choice appears in the display.



NOTE: If the display shows "REMOVE PAPER JAM AND PRESS CANCEL" when you have closed the cartridge door, re-install the cartridge(s). With the print cartridge(s) installed improperly, the product might not print.

- 7 The display prompts you to confirm a new or an old cartridge. Press the **Scroll** buttons (◀ or ▶) to scroll through the options and press **Enter** when your choice appears in the display.

The available options for the right cartridge are: NEW BLACK, OLD BLACK, NEW PHOTO, and OLD PHOTO. If you installed a photo cartridge instead of a black cartridge, select "NEW PHOTO" or "OLD PHOTO".

- 8 The display prompts you to confirm the cartridge capacity: Standard or High Yield. Use the **Scroll** buttons (◀ or ▶) to scroll through the options and press **Enter** when your choice appears in the display.

If you installed a photo cartridge, you don't have to select the capacity of the photo cartridge because your product supports only a standard photo cartridge.

- 9 When you finish setting the cartridge(s) and if any new cartridge is installed, the cartridge alignment procedure begins automatically by printing the Cartridge Alignment form.

Refer to step 5 under "Aligning Print Cartridges" on page 6.16.

If you installed an old cartridge(s), the product returns to Standby mode without printing the Cartridge Alignment form.



NOTE: If you reinstall the printer driver, the ink level on the Printer Control Program may be incorrect even when you do not change the cartridges.



Replacing Print Cartridges from the Computer

- 1 Click **Start > Programs > Samsung SCX-1150 Series > Printer Control Program**. You have accessed the Samsung SCX-1150 Series Control Program.
- 2 Select the **Cartridges** tab. Click **Install/Change Cartridge**.
- 3 Open the cartridge door and replace the old cartridge(s) by following the instructions on page 6.11.

- 4 When you finish installing cartridge(s), click the appropriate buttons in the Samsung SCX-1150 Series dialogue box to confirm the type of the cartridges you have installed.

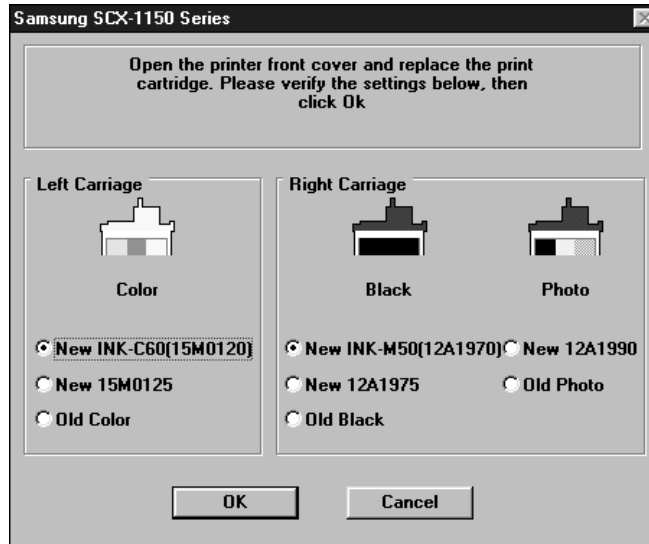

▲ In the case of Windows 98

- 5 When you finish, click **OK**. If you have installed one or both cartridges as new, the message dialogue box appears to prompt you to align the cartridge. Click **Align**.
- 6 Your product prints the Cartridge Alignment form. Complete the alignment procedure by following the instructions on the page 6.17.

If you installed an old cartridge(s), the product returns to Standby mode without printing the Cartridge Alignment form.



NOTE: In Windows 2000/XP, the Printer Control Program is unavailable. But, you can access the Cartridge Maintenance features through the printer properties by taking the following steps:

1. Click **Start > Settings > Printers**.
2. Right-click on **Samsung SCX-1150 Series** printer in the Printers folder.
3. From the pop-up list, select **Properties**.
4. Click the **Cartridge Maintenance** tab.

Aligning Print Cartridges

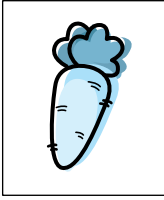

You must align the black and colour print cartridges after installing a new print cartridge or if the black portions of graphics do not align with the colour portions.

Cartridge alignment can be done from the computer using the Samsung SCX-1150 Series Control Program or from the operation panel of your product.



Aligning Print Cartridges from the Product

- 1 Press the **Setup**. The display shows "1.SYSTEM SETUP" on the bottom line.
- 2 Press the **Scroll** buttons (◀ or ▶) until you see "8.MAINTENANCE" and then press **Enter**.
- 3 Press the **Scroll** buttons (◀ or ▶) until you see "ALIGN CARTRIDGE" on the bottom line of the display and then press **Enter**.
- 4 The product feeds a sheet of paper and prints the Cartridge Alignment form.

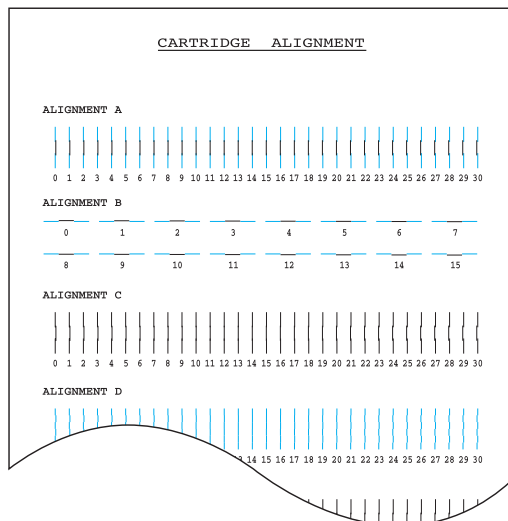

- From each group on the form, locate the number under the alignment pattern that comes closest to forming a perfectly straight line.
- The alignment entry menu appears on the display. The letter on the right end of the display corresponds to the alignment pattern. The range of numbers in the centre of the display indicates the range of valid selection choices. The flashing number on the left side of the display indicates the line from the form that is currently selected as optimal.

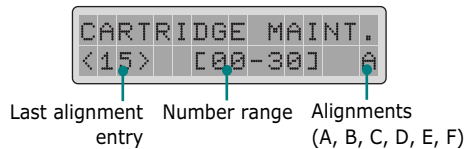

- Using the number keypad enter the number of the line which appears the straightest from pattern A (example - for the second line, enter 02).

Press **Enter** to confirm your selection. The alignment entry menu for the Alignment B pattern is displayed.

- Repeat step 7 for Alignment patterns B through F (or D for colour and photo cartridges).
- After you enter the number for the last group, Alignment F (or D for colour and photo cartridges), the display automatically returns to the Standby mode.



Aligning Print Cartridges from the Computer

- Click **Start > Programs > Samsung SCX-1150 Series > Printer Control Program**. You have accessed the Samsung SCX-1150 Series Control program.
- Select the **Cartridges** tab.
- Click **Align Cartridges**.

- 4 The product feeds a sheet of paper and prints the Alignment Cartridge form. The Align Cartridges dialogue box appears.

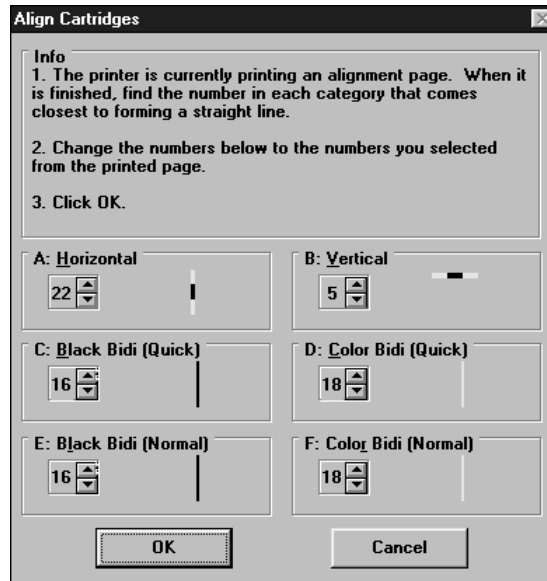

- 5 Locate the number under each alignment group in the pattern that comes closest to forming a perfect straight line. Then enter the number of the line or click repeatedly the ▲ or ▼ key to select the number.
- 6 When the procedure is finished, click **OK**.



NOTE: In Windows 2000/XP, the Printer Control Program is unavailable. But, you can access the Cartridge Maintenance features through the printer properties by taking the following steps:

1. Click **Start > Settings > Printers**.
2. Right-click on **Samsung SCX-1150 Series** printer in the Printers folder.
3. From the pop-up list, select **Properties**.
4. Click the **Cartridge Maintenance** tab.

Clearing Memory

You can selectively clear information stored in your product's memory.

- 1** Press **Setup**. The display shows "1.SYSTEM SETUP" on the bottom line.
- 2** Press the **Scroll** buttons (◀ or ▶) until you see "7.MEMORY CLEAR" and then press **Enter**.
- 3** Press the **Scroll** buttons (◀ or ▶) until you find the item you want to clear. The following options are available:
 - **FAX NUMBER/NAME:** Your fax number and name are cleared from memory.
 - **DIAL/SCHEDULE:** clears the phonebook numbers, one-touch, speed dial, or group dial numbers stored in the memory. Also, all Schedule Job operations reserved are canceled.
 - **JOURNAL:** clears all records of transmissions & receptions.
 - **DEFAULT SETUP:** restores all settings to factory default.
- 4** Press **Enter** when your choice appears in the bottom line of the display. The selected item is cleared and then the display returns to Standby mode.

Remote Test

The Remote Test feature allows your product to be checked out by a service company at a remote place by phone.

- 1** Press **Setup**. The display shows "1.SYSTEM SETUP" on the bottom line.
- 2** Press the **Scroll** buttons (◀ or ▶) until you see "8.MAINTENANCE" and then press Enter.
- 3** Press the **Scroll** buttons (◀ or ▶) until you see "REMOTE TEST" on the bottom line of the display and then press **Enter**. The current setting displays.
- 4** Press the **Scroll** buttons (◀ or ▶) to select "ON" to turn the feature on. If you want to protect your product from being accessed by unauthorized person, select "OFF".
- 5** Press **Enter** to save the selection.

Cleaning the Document Glass

To keep your product working properly, occasionally clean the document glass.

Clean the document glass with a soft cloth. Do not spray the cleaner directly onto the document glass. Always spray the cleaner onto the cloth.

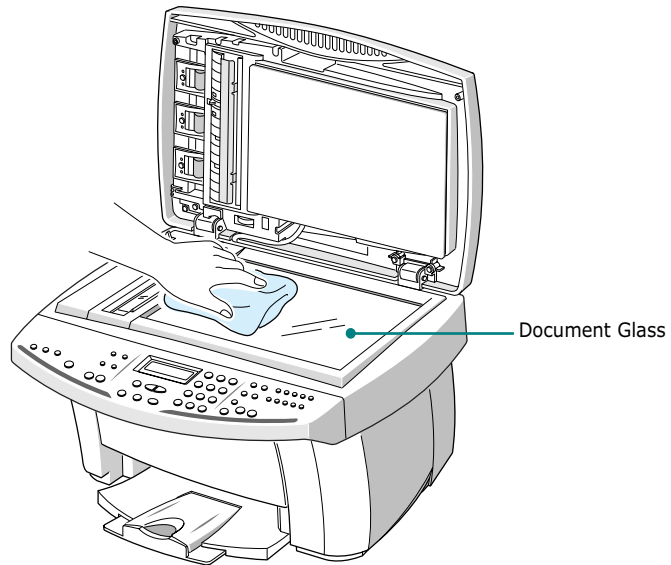

7

TROUBLESHOOTING

This chapter gives helpful information for what to do if you encounter an error.

This chapter includes:

- **Clearing Document Jams**
- **Clearing Paper Jams**
- **LCD Error Messages**
- **Fixing Problems**

Clearing Document Jams

If a document jams while it is feeding through the ADF, "DOCUMENT JAM" appears in the display.

Details for clearing the three types of document misfeeds are given below.

Input Misfeed

- 1 Open the ADF top cover.

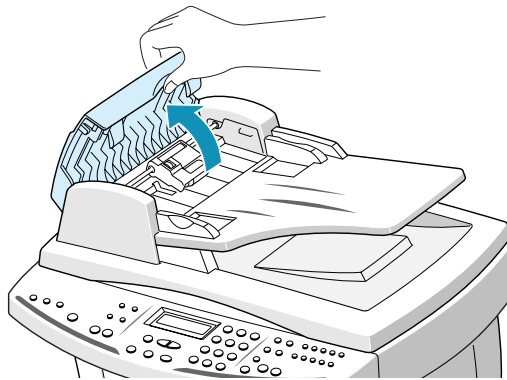

- 2 Carefully pull the jammed document out of the ADF mechanism, taking care not to tear the paper.

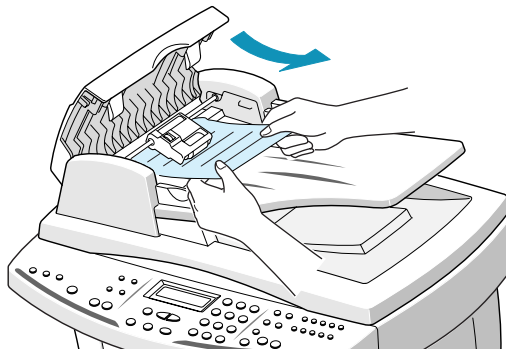

- 3 Close the ADF top cover.
- 4 Feed the documents back into the ADF.

Exit Misfeed

- 1 Open the document cover and turn the roller knob to remove the misfeed documents from the exit area.

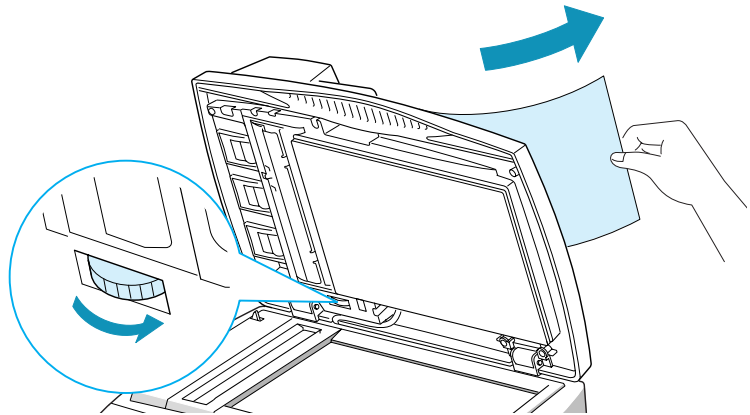

If the jammed document cannot be easily removed, skip to the Roller Misfeed section.

- 2 Close the document cover.
- 3 Feed the documents back into the ADF.

Roller Misfeed

- 1 Open the document cover and turn the roller knob to remove the misfeed document from the ADF or the exit area. If the document is difficult to remove, gently remove it from under the feeding roller.

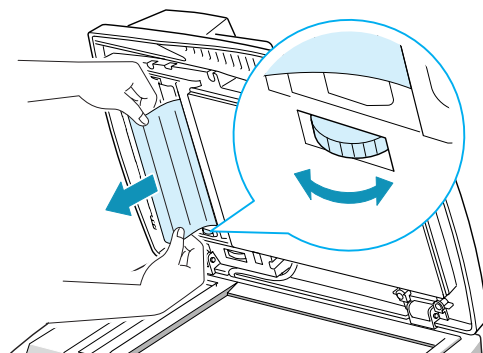

- 2 Close the document cover.
- 3 Feed the documents back into the ADF.

Clearing Paper Jams

If paper jams occur, "REMOVE PAPER JAM AND PRESS CANCEL" appears in the display. Follow the steps below to clear the jam. To avoid tearing paper, pull the jammed paper out gently and slowly.

If jammed in the paper feed area at the rear of the product:

- 1** Remove the stack of paper (if necessary).
- 2** Remove the jammed paper by gently pulling it straight up.

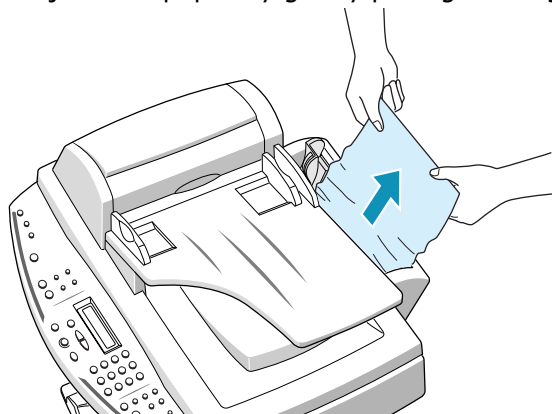

- 3** After you remove the jammed paper, reload the stack of paper back into the paper bin with the print side facing you. Before loading, ensure the edges of the stack of paper are even and straight.
- 4** Adjust the paper guide to match the width of the paper.

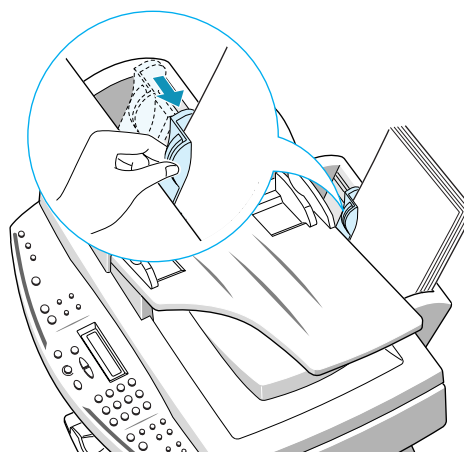

- 5** If the paper jams as it exits to the paper output tray, remove the jammed paper by pulling gently on the paper.

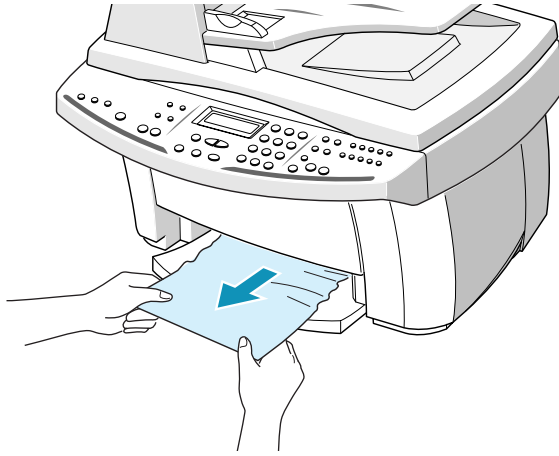

- 6** Press **Cancel/Reset** to clear the error message on the display.



NOTE: If there is any resistance, and the paper does not move immediately when you pull, open the cartridge door and gently pull the jammed paper out of the printer.



Tips for Avoiding Paper Jams

By carefully selecting print materials and loading them properly, you should be able to avoid most paper jams. If jams do occur, follow the steps outlined in "Clearing Paper Jams" starting on page 7.4. If jams occur frequently, make sure that you are following these preventative tips:

- Follow the procedures in "Loading Paper" on page 1.11 to load paper properly. Make sure that the adjustable guides are positioned correctly.
- Do not overload the paper. Up to 100 sheets can be loaded in the paper bin at a time.
- Envelopes with self-stick adhesives may cause wrinkling, creasing, or even jams and may even damage your product.
- Fan stacks of labels or transparencies before loading them into the paper input bin. If jams occur, try feeding one sheet at a time.
- Do not load wrinkled, creased, damp, or highly curled paper.
- Do not mix paper sizes in the paper input bin.
- Use only recommended print media.
- Make sure that the recommended print side is facing up when loading it in the paper input bin.
- Keep print media stored in a suitable environment.

LCD Error Messages

| LCD Display | Meaning | Solution |
|---|---|--|
| CHECK CARTRIDGES CHECK LEFT CARTRIDGE CHECK RIGHT CARTRIDGE | The indicated ink cartridge is not installed or installed improperly. Or there is a problem on the indicated cartridge. | Following the procedure in "Replacing Print Cartridges" on page 6.9, remove and re-install the print cartridge. |
| CHANGE COLOR INK CHANGE BLACK INK CHANGE PHOTO INK | The indicated ink cartridge is low or out of ink. | Install a new ink cartridge. |
| COVER OPEN | The cartridge door is not securely latched. | Press down on the cartridge door until it clicks in place. |
| REMOVE PAPER JAM AND PRESS CANCEL | Paper jammed while printing. | Clear the jam. Refer to "Clearing Paper Jams" on page 7.4. |
| SYSTEM ERROR | Internal system errors detected. | Look for obvious error conditions. If the problem persists, power the product off and on. Contact the nearest dealer. |
| ADD PAPER THEN PRESS ENTER | The paper bin is empty. | If the product runs out of paper while printing, it will restart printing when more paper is loaded. Press Enter after loading paper. |
| PRINTER ERROR | An unknown printer error has occurred. | Turn off your product then on. If you still have the problem, please contact your dealer. |
| SYSTEM BUSY | You have tried to use the system when it is currently in use. | Wait for the current job to complete, then try again. |
| DOCUMENT JAM | The loaded document has jammed in the ADF. | Clear the document jam. See page 7.2. |
| LOAD BLACK INK | The photo cartridge is installed when: - receiving a fax - copying in Draft quality | Replace the photo cartridge with black one. |



Fixing Problems

Fax Problems

| Symptom | Cause and Solution |
|--|--|
| The product is not working, there is no display and the buttons are not working. | <ul style="list-style-type: none">• Unplug the power cord and plug it in again.• Check that your socket is active. |
| No dial tone. | <ul style="list-style-type: none">• Check that the phone line is connected properly.• Check that the phone socket in the wall by plugging in another phone. |
| The numbers stored in the memory do not dial correctly. | <ul style="list-style-type: none">• Make sure that the numbers are stored in the memory correctly.• Print a Phonebook list. See page 5.39. |
| The document does not feed into the product. | <ul style="list-style-type: none">• Make sure that the document is not wrinkled and you are putting it in correctly. Check the document is the right size, not too thick or thin.• Make sure that the cover is firmly closed. |
| You cannot receive faxes automatically. | <ul style="list-style-type: none">• The FAX mode should be selected.• Is there paper in the product?• Check if the display shows 'MEMORY FULL.' |
| Your product cannot receive faxes manually. | Did you hang up the handset of the external telephone before you pressed any of the Start FAX buttons? |
| Your product will not send anything. | <ul style="list-style-type: none">• Make sure that the document is loaded face up in the ADF and face down in the document glass.• "TX" should show up on the display.• Check the other fax machine you are sending to, to see if it can receive your fax. |
| You cannot poll another machine. | The fax machine you are polling may be using a poll code. |

| Symptom | Cause and Solution |
|---|---|
| <p>The incoming fax has blank spaces or you received a poor-quality copy.</p> | <ul style="list-style-type: none"> • The fax machine sending you the fax may be faulty. • The fax machine sending you a fax may have a dirty scan glass. • A noisy phone line can cause line errors. • Check your product by making a copy. • The print cartridge may be empty. • Haven't you force the product to print out with any (or both) cartridge not installed? Your product can function with only one or no cartridge installed, but the quality cannot be normal. |
| <p>Are some of the words on the incoming fax stretched?</p> | <p>The fax machine sending you the fax had a temporary document jam.</p> |
| <p>There are lines on the copies or documents you send.</p> | <p>Check your scan glass for marks, and clean it. See page 6.20.</p> |
| <p>The product dials a number, but fails to make a connection with another fax machine.</p> | <p>The other fax machine may be turned off, out of paper, or cannot answer incoming calls. Speak with the other machine operator and ask them to sort out the problem.</p> |
| <p>You cannot store a document in the memory.</p> | <p>There may not be enough memory to store the document. If the display shows "MEMORY FULL", delete any documents you no longer need from the memory, then restore the document.</p> |
| <p>Blank areas appear at the bottom of each page or on other pages, with only a small strip of text printed at the top.</p> | <p>You may have chosen the wrong paper settings in the user option setting. See page 5.42 to choose a proper paper size.</p> |



Paper Feeding Problems

| Symptom | Cause and Solution |
|--|---|
| Paper is jammed during printing. | Clear the paper jam. See page 7.4. |
| Paper sticks together. | <ul style="list-style-type: none"> • Ensure there is not too much paper in the paper bin. Depending on the thickness of your paper, the paper bin can hold up to 100 sheets of paper. • Make sure you are using the correct type of paper. See “Paper Selection” on page 2.2. • Remove paper from the paper bin and flex or fan the paper. • Humid conditions may cause some paper to stick together. |
| Paper fails to feed. | <ul style="list-style-type: none"> • Remove any obstructions inside the product. |
| Multiple sheets of paper do not feed. | <ul style="list-style-type: none"> • Different types of paper may be stacked in the paper bin. Load the paper of only one type, size, and weight. • When loading paper, do not force the paper down into the printer. • If multiple sheets have caused a paper jam, clear the paper jam. See page 7.4. |
| Paper skews or buckles. | <ul style="list-style-type: none"> • Ensure there is not too much paper in the paper bin. Depending on the thickness of your paper, the paper bin can hold up to 100 sheets of paper. • Make sure the paper guide does not cause the paper to bow in the paper bin. • Make sure you are using the correct type of paper. See “Paper Selection” on page 2.2. • When loading paper, do not force the paper down into the product. • Make sure the right side of the paper is aligned with the right edge of the paper bin, and the left paper guide is set against the left side of the paper. |
| Transparencies stick together in the paper exit. | Use only the transparencies specially designed for an ink jet printer. Remove each transparency as it exits from the printer. |
| Envelopes skew or fail to feed correctly. | Ensure that the paper guide is against the left side of the envelopes. |

General Printing Problems

| Symptom | Cause and Solution |
|---|---|
| Your product does not print. | <ul style="list-style-type: none"> • The printer cable is not connected properly. Check the printer cable connection. • The printer cable is defective. Swap the cable with one known to work. • The port setting is incorrect. Check the Windows printer settings to make sure that the print job is being sent to the correct port (for example, LPT1). • The print cartridge is not installed properly. Remove and reinsert the print cartridge. • The printer properties may be configured incorrectly. Check the application to make sure that all print settings are correct. • The printer driver may be incorrectly installed. Uninstall the MFP driver and reinstall the MFP driver. Then try printing a test page. Refer to “Uninstalling Samsung Software” on page 1.28. • A paper jam has occurred. Remove the jammed paper. See page 7.4. • For Windows 2000/XP, if you remove the product from the PC and then connect back to the PC, the printer might be set to Off line status. Open the Windows Printer folder and check if the product is off line. If so, right-click on Samsung SCX-1150 Series printer and deselect Use Printer Offline. |
| A file sent from Acrobat Reader 4.0 does not print or print improperly. | <ul style="list-style-type: none"> • From the Acrobat Reader File menu, select Print and check the Print as image box. If it does not solve the problem, upgrade Acrobat Reader to 5.0 or higher. |
| The paper is not fed into the product. | <ul style="list-style-type: none"> • Paper has not been inserted correctly. Remove and reinsert the paper correctly (refer to “Loading Paper” on page 1.11). • There is too much paper in the paper bin. Remove some of the paper from the paper bin. |
| The paper keeps jamming. | <ul style="list-style-type: none"> • There is too much paper in the paper bin. Remove some of the paper from the paper bin. (If printing onto transparencies, or labels, insert them one at a time.) • The paper setting method may be incorrect. If printing onto envelopes, insert the envelopes so that there is a gap of approximately 1 mm (1/32”) between the left and right edge of the envelopes at the paper guide. |

| Symptom | Cause and Solution |
|--|---|
| Part of the printed page is blank. | <ul style="list-style-type: none"> • The page layout is too complex. Simplify the page layout and remove any unnecessary graphics from the document if possible. • The page orientation setting may be incorrect. Change the page orientation in the Printer Properties dialogue box. • The paper size and the software paper size settings do not match. Insert the correct paper into the product or change the software paper size settings. • Scaling may be set to less than 100%. Change the Scaling setting in the Printer Properties dialogue box. • If using a parallel cable, ensure that it is compliant with an IEEE-1284 rated cable. |
| Your product prints the wrong data, or it prints incorrect characters. | <ul style="list-style-type: none"> • The printer cable might not be connected properly. Check the printer cable connection. • There may be a problem with the printer driver software. Exit Windows and reboot the computer. Turn the printer off and then back on again. • If using a parallel cable, ensure that it is compliant with an IEEE-1284 rated cable. |
| Printing is too slow. | <ul style="list-style-type: none"> • You may be using High and Maximum print quality. See page 2.10. • If you are using Windows NT, the Scheduling setting may be set incorrectly. From the Start menu, select Settings and Printers. Click your printer icon with the right mouse button, select Properties, click the Scheduling tab. Then, select the desired scheduling setting from the available choices. |
| When printing using the USB connection, an error occurs repeatedly. | <p>When the USB mode is set to "FAST", the communication between the product and the computer may be poor. Change the USB mode to "SLOW". To do so, take the following steps:</p> <ol style="list-style-type: none"> 1. Press Setup on the operation panel. You can see "1.SYSTEM SETUP" on the bottom line of the display. 2. Press Enter. 3. Press the Scroll buttons (◀ or ▶) until you see "USB MODE" and then press Enter. 4. Press the Scroll buttons (◀ or ▶) to select "SLOW" and then press Enter to save the selection. |

Colour Printing Problems

| Symptom | Cause and Solution |
|---|---|
| Your product prints only in black. | <ul style="list-style-type: none"> • The Samsung SCX-1150 Series printer driver may not be selected. Verify that you selected the Samsung SCX-1150 Series printer driver. • The colour print cartridge may not be working properly. Print a test page to make sure the ink cartridges are working correctly. • The print nozzles of the colour print cartridge may need to be cleaned. Clean the print cartridges. See page 6.3. • You may be using Black Only in your printer driver. |
| Colour prints incorrectly. | <ul style="list-style-type: none"> • The Samsung SCX-1150 Series printer driver may not be selected. Verify that you selected the Samsung SCX-1150 Series printer driver. • Print cartridges may be installed in the incorrect holders. Remove each print cartridge that is in an incorrect holder. Check that the ink have not mixed in the cartridges. If this is the case, replace the cartridge with a new one. • Print a test page. If the problem persists, replace the cartridge with new one. • Print nozzles on the colour print head may be clogged. Print a test page to check the status of the nozzles and clean the print cartridge (see page 6.3). |
| Colours are missing. | <ul style="list-style-type: none"> • The colour print cartridge may be not working properly. Print a test page to make sure the ink cartridge is working correctly. • The print head may need to be cleaned. Clean the print cartridges (see page 6.3). |
| Colours in a line are uneven, or different from the previous lines. | <ul style="list-style-type: none"> • You may have turned the product off(paused) and then on(resumed) during print job. Do not turn the product off and back on during a print job. • Set the print quality to High or Maximum in the printer driver. • Align the print cartridges. See page 6.15. |
| Hue changes. | <ul style="list-style-type: none"> • Print nozzles on the print head may be clogged. Print a test page to check the status of the nozzles and clean the print cartridge (page 6.3). • The colour print cartridge may be empty. Replace the cartridge with a new one. |



Print Quality Problems

| Symptom | Cause and Solution |
|-------------------------------|--|
| Light print or fade | <ul style="list-style-type: none"> • The print cartridge may be running out of ink. Install a new ink cartridge. • The paper may not meet paper specifications (for example, the paper is too moist or too rough). See "Paper Selection" on page 2.2. • If the whole page is light, the print resolution setting is too low. Adjust the print resolution within the printer properties. See page 2.10. • A combination of faded and smeared defects may indicate that the print cartridges need to be cleaned. See "Cleaning Print Cartridges" on page 6.3. |
| Splashed dots | <ul style="list-style-type: none"> • The paper may not meet paper specifications (for example, the paper is too moist or too rough). "Paper Selection" on page 2.2. • The print nozzles may be clogged with ink. See "Cleaning Print Cartridges" on page 6.3. |
| White streaks or missing dots | <ul style="list-style-type: none"> • The moisture content of the paper is uneven or the paper has moist spots on its surface. Try a different kind or brand of paper. • Print cartridges may be installed incorrectly. Make sure the print cartridges are installed correctly. • A print cartridge may be empty. Check the contacts of the print cartridge. If there is not any ink in the cartridge, replace it with a new one. • The print media being used may not be acceptable. Use only print media specified in "Paper Selection" on page 2.2. • The print head may be aligned incorrectly. Print the alignment pattern to align the print cartridge. See page 6.15. |
| Blurred or smudged ink | <ul style="list-style-type: none"> • You may printing on the wrong side of the paper. Turn the paper over and print on the other side. • The paper may not meet paper specifications (for example, too moist or too rough). See "Paper Selection" on page 2.2. • Let the ink dry before handling the paper. |

| Symptom | Cause and Solution |
|---|---|
| Characters with white lines | <ul style="list-style-type: none"> • The print cartridge may be almost empty. Check the contacts of the print cartridge and replace, if necessary. • The print cartridges may need to be cleaned. See page 6.3. |
| Characters are improperly formed or not aligned correctly | <ul style="list-style-type: none"> • The print media is loaded incorrectly or is an unsupported size or type. Use the print media specified in "Paper Selection" on page 2.2. • If characters are improperly formed, producing a wavy effect, the scanner unit may need servicing. • The print cartridges may need to be cleaned. See page 6.3. • The print cartridges may need to be aligned. See page 6.15. |
| Vertical lines in tables, borders and graphics not smooth | <ul style="list-style-type: none"> • The print cartridge may need to be cleaned. See page 6.3. • The print cartridge may need to be aligned. See page 6.15. |
| Solid black areas contain white streaks | <ul style="list-style-type: none"> • Change the fill pattern in the application software. |
| Printing appears jagged | <ul style="list-style-type: none"> • The print resolution selected in the printer driver may be low. Check the printer driver for the correct resolution. Printing in low resolution will give the printout a jagged look. Change the Print Quality to a higher resolution. |



Scanning Problems

| Symptom | Cause and Solution |
|--|--|
| <p>The scanner does not scan.</p> | <ul style="list-style-type: none"> • Make sure you place the document to be scanned face down on the document glass. • There may not be enough available memory to hold the document you want to scan. Try the Pre-Scan function to see if that works. Try lowering the scan resolution rate. • The USB or parallel cable is not connected properly. • The USB or parallel cable is defective. Swap the cable with a known good cable. If necessary, replace the cable. • If using a parallel cable, ensure that it is compliant with the IEEE 1284 standard. • The scanner is configured incorrectly. Check scan setting in the SmarThru Configuration or the application you want to use to make certain that the scanner job is being sent to the correct port (for example, LPT1). |
| <p>The unit scans very slowly.</p> | <ul style="list-style-type: none"> • Graphics are scanned more slowly than text. • Communication speed becomes slow in scan mode because of the large amount of memory required to analyse and reproduce the scanned image. Set your computer to ECP printer mode through BIOS setting. It will help to increase the speed. For details on how to set BIOS, refer to your PC documentation. |
| <p>The following message appears on the computer screen: Scanner is busy receiving or printing data. When the current job is completed, try again.</p> | <p>There may be a copying or printing job in progress. When the current job is completed, try the job again.</p> |



8

APPENDIX

This chapter includes:

- **Printer Specification**
- **Scanner and Copier Specification**
- **Fax Specification**
- **General Specification**
- **Paper Specification**
- **Replacing the Fitted Plug (UK)**
- **Notes For Use of This Device (New Zealand)**
- **Declaration of Conformity (European Countries)**
- **Fax Branding (US)**
- **Telephone Company Information (US)**

Printer Specification

| Item | Description |
|------------------------------------|--|
| Emulation | HBP(GDI) |
| Resolution | True 600 x 1200 dpi, 2400(H) x 1200(V) dpi |
| Printing speed (Draft Mode) | 14 ppm (Mono) 7 ppm (Colour) |
| Effective printing width | 203 ± 1 mm |

Scanner and Copier Specification

| Item | Description |
|------------------------------------|---|
| Scanning method | CCD, Flat-bed |
| Scan resolution | 600 x 600 dpi, 1200 dpi class |
| Scan mode | True colour, 256 grey, Black and white |
| Copy mode | Colour, Black and white |
| Effective scanning width | 210 mm |
| Maximum document width | 216 mm |
| Multi copy range | 1 ~ 99 |
| Reduction & Enlargement | 25% ~ 400% in 1% increment(Flatbed) 25% ~ 100% in 1% increment(ADF) |
| Maximum print edge margin | Top: MAX 4mm Bottom: MAX 5mm Side: Letter — 6.5 ± 2 mm A4 — 3.5 ± 2 mm |

Fax Specification

| Item | Description |
|----------------------------------|---|
| Applicable line | G3 PSTN (Public Switched Telephone Network) |
| Compatibility | ITU Group 3 |
| Resolution | Standard: 203 x 98 dpi Fine: 203 x 196 dpi Super Fine: 300 x 300 dpi |
| Data coding | MH/MR/MMR/JPEG |
| Maximum modem speed | 33.6 kbps |
| Transmission speed | 3 sec. (Standard resolution, MMR, 33.6 kbps) |
| Memory | 4 Mbytes |
| Effective scanning width | 210 mm |
| Effective printing width | 203 mm |
| Document width and weight | ADF: 176 ~ 216 mm, 16 lb ~ 24 lb Document glass: Maximum 8.5 x 14 inches |
| Document capacity | ADF: up to 30 pages (20 lb) Document glass: 1 page |



General Specification

| Item | Description |
|---|---|
| Input paper tray capacity | 100 sheets (Maximum) Stacking Height : 9 mm |
| Output tray capacity | Maximum 30 Sheets |
| Operating Environment | Temperature: 5-40 degrees C (20 ~ 80% RH) |
| Paper size and weight | A4, Letter, Legal |
| Original document width and weight | 8.5 inch x 11.69 inch (A4/Letter Sized) |
| Power rating | See Rating Label attached on the back of the machine. |
| Power consumption | 10 W in Power save mode 15 W in Standby mode 30 W during copy |
| Weight | 9.5 kg |
| Dimensions (WxDxH) | 18.7 x 16.9 x 9.9 inch (476 x 429 x252 mm) |
| Ink Cartridge Life | Black Cartridge High yield: 1,100 sheets Standard: 600 sheets (based on ITU 5% chart* in PC Draft print mode) |
| | Colour Cartridge High yield: 625 sheets Standard: 275 sheets (based on ITU 5% chart* in PC Draft print mode) |
| | Photo Cartridge: 450 sheets (based on ITU 5% chart* in PC Draft print mode) |

* See "A Sample of ITU 5% Chart (reduced to 60%)" on page 8.6.

Paper Specification

| Item | Description | | | | | | | | | | | | | | | | | | | | | | | | | | | | | | | | | | | | | | | | | | | | | | | |
|------------------------------|--|------------------------|--|------------|------------|--------------|--------|-------------|----------|-------|---------------|----------|--------|-----------|--------------|----|----------|--------------|-----------|---------------|-------------|----|-------------|-------------|---------|-------------|-------------|---------------|---------------|-------|--------|-----------|-------------|----------------|--------------|------------|-----------------|-----------|------------|-------------|-----------|-------------|-------------|-----------|-------------|--------|-------------------------|------------------------|
| Paper types available | Plain paper, OHP film, Label, Envelope, Card, Postcard | | | | | | | | | | | | | | | | | | | | | | | | | | | | | | | | | | | | | | | | | | | | | | | |
| Paper sizes | <table border="1"> <thead> <tr> <th data-bbox="467 401 731 440">Paper Type</th> <th data-bbox="731 401 954 440">W x L (mm)</th> <th data-bbox="954 401 1190 440">W x L (Inch)</th> </tr> </thead> <tbody> <tr> <td data-bbox="467 440 731 488">Letter</td> <td data-bbox="731 440 954 488">215.9 x 279</td> <td data-bbox="954 440 1190 488">8.5 x 11</td> </tr> <tr> <td data-bbox="467 488 731 537">Legal</td> <td data-bbox="731 488 954 537">215.9 x 355.6</td> <td data-bbox="954 488 1190 537">8.5 X 14</td> </tr> <tr> <td data-bbox="467 537 731 585">JIS B5</td> <td data-bbox="731 537 954 585">182 x 257</td> <td data-bbox="954 537 1190 585">7.17 x 10.12</td> </tr> <tr> <td data-bbox="467 585 731 633">A4</td> <td data-bbox="731 585 954 633">210x 297</td> <td data-bbox="954 585 1190 633">8.27 x 11.69</td> </tr> <tr> <td data-bbox="467 633 731 681">Executive</td> <td data-bbox="731 633 954 681">184.2 x 266.7</td> <td data-bbox="954 633 1190 681">7.25 x 10.5</td> </tr> <tr> <td data-bbox="467 681 731 730">A5</td> <td data-bbox="731 681 954 730">148.5 x 210</td> <td data-bbox="954 681 1190 730">5.85 x 8.27</td> </tr> <tr> <td data-bbox="467 730 731 778">A6 card</td> <td data-bbox="731 730 954 778">105 x 148.5</td> <td data-bbox="954 730 1190 778">4.13 x 5.85</td> </tr> <tr> <td data-bbox="467 778 731 826">Post Card 4x6</td> <td data-bbox="731 778 954 826">101.6 x 152.4</td> <td data-bbox="954 778 1190 826">4 x 6</td> </tr> <tr> <td data-bbox="467 826 731 875">HagaKi</td> <td data-bbox="731 826 954 875">100 x 148</td> <td data-bbox="954 826 1190 875">3.94 x 5.83</td> </tr> <tr> <td data-bbox="467 875 731 923">Envelope 7-3/4</td> <td data-bbox="731 875 954 923">98.4 x 190.5</td> <td data-bbox="954 875 1190 923">3.88 x 7.5</td> </tr> <tr> <td data-bbox="467 923 731 971">Envelope COM-10</td> <td data-bbox="731 923 954 971">105 x 241</td> <td data-bbox="954 923 1190 971">4.13 x 9.5</td> </tr> <tr> <td data-bbox="467 971 731 1020">Envelope DL</td> <td data-bbox="731 971 954 1020">110 x 220</td> <td data-bbox="954 971 1190 1020">4.33 x 8.66</td> </tr> <tr> <td data-bbox="467 1020 731 1068">Envelope C5</td> <td data-bbox="731 1020 954 1068">162 x 229</td> <td data-bbox="954 1020 1190 1068">6.38 x 9.02</td> </tr> <tr> <td data-bbox="467 1068 731 1124">Custom</td> <td data-bbox="731 1068 954 1124">76 ~ 216 x 127 ~ 432</td> <td data-bbox="954 1068 1190 1124">2.99 ~ 8.5 x 5 ~ 17</td> </tr> </tbody> </table> | | | Paper Type | W x L (mm) | W x L (Inch) | Letter | 215.9 x 279 | 8.5 x 11 | Legal | 215.9 x 355.6 | 8.5 X 14 | JIS B5 | 182 x 257 | 7.17 x 10.12 | A4 | 210x 297 | 8.27 x 11.69 | Executive | 184.2 x 266.7 | 7.25 x 10.5 | A5 | 148.5 x 210 | 5.85 x 8.27 | A6 card | 105 x 148.5 | 4.13 x 5.85 | Post Card 4x6 | 101.6 x 152.4 | 4 x 6 | HagaKi | 100 x 148 | 3.94 x 5.83 | Envelope 7-3/4 | 98.4 x 190.5 | 3.88 x 7.5 | Envelope COM-10 | 105 x 241 | 4.13 x 9.5 | Envelope DL | 110 x 220 | 4.33 x 8.66 | Envelope C5 | 162 x 229 | 6.38 x 9.02 | Custom | 76 ~ 216 x 127 ~ 432 | 2.99 ~ 8.5 x 5 ~ 17 |
| Paper Type | W x L (mm) | W x L (Inch) | | | | | | | | | | | | | | | | | | | | | | | | | | | | | | | | | | | | | | | | | | | | | | |
| Letter | 215.9 x 279 | 8.5 x 11 | | | | | | | | | | | | | | | | | | | | | | | | | | | | | | | | | | | | | | | | | | | | | | |
| Legal | 215.9 x 355.6 | 8.5 X 14 | | | | | | | | | | | | | | | | | | | | | | | | | | | | | | | | | | | | | | | | | | | | | | |
| JIS B5 | 182 x 257 | 7.17 x 10.12 | | | | | | | | | | | | | | | | | | | | | | | | | | | | | | | | | | | | | | | | | | | | | | |
| A4 | 210x 297 | 8.27 x 11.69 | | | | | | | | | | | | | | | | | | | | | | | | | | | | | | | | | | | | | | | | | | | | | | |
| Executive | 184.2 x 266.7 | 7.25 x 10.5 | | | | | | | | | | | | | | | | | | | | | | | | | | | | | | | | | | | | | | | | | | | | | | |
| A5 | 148.5 x 210 | 5.85 x 8.27 | | | | | | | | | | | | | | | | | | | | | | | | | | | | | | | | | | | | | | | | | | | | | | |
| A6 card | 105 x 148.5 | 4.13 x 5.85 | | | | | | | | | | | | | | | | | | | | | | | | | | | | | | | | | | | | | | | | | | | | | | |
| Post Card 4x6 | 101.6 x 152.4 | 4 x 6 | | | | | | | | | | | | | | | | | | | | | | | | | | | | | | | | | | | | | | | | | | | | | | |
| HagaKi | 100 x 148 | 3.94 x 5.83 | | | | | | | | | | | | | | | | | | | | | | | | | | | | | | | | | | | | | | | | | | | | | | |
| Envelope 7-3/4 | 98.4 x 190.5 | 3.88 x 7.5 | | | | | | | | | | | | | | | | | | | | | | | | | | | | | | | | | | | | | | | | | | | | | | |
| Envelope COM-10 | 105 x 241 | 4.13 x 9.5 | | | | | | | | | | | | | | | | | | | | | | | | | | | | | | | | | | | | | | | | | | | | | | |
| Envelope DL | 110 x 220 | 4.33 x 8.66 | | | | | | | | | | | | | | | | | | | | | | | | | | | | | | | | | | | | | | | | | | | | | | |
| Envelope C5 | 162 x 229 | 6.38 x 9.02 | | | | | | | | | | | | | | | | | | | | | | | | | | | | | | | | | | | | | | | | | | | | | | |
| Custom | 76 ~ 216 x 127 ~ 432 | 2.99 ~ 8.5 x 5 ~ 17 | | | | | | | | | | | | | | | | | | | | | | | | | | | | | | | | | | | | | | | | | | | | | | |



A Sample of ITU 5% Chart (reduced to 60%)



THE SLEREXE COMPANY LIMITED

SAPORS LANE - BOOLE - DORSET - BH 25 8 ER

TELEPHONE BOOLE (945 13) 51617 - TELEX 123456

Our Ref. 350/PJC/EAC

18th January, 1972.

Dr. P.N. Cundall,
Mining Surveys Ltd.,
Holroyd Road,
Reading,
Berks.

Dear Pete,

Permit me to introduce you to the facility of facsimile transmission.

In facsimile a photocell is caused to perform a raster scan over the subject copy. The variations of print density on the document cause the photocell to generate an analogous electrical video signal. This signal is used to modulate a carrier, which is transmitted to a remote destination over a radio or cable communications link.

At the remote terminal, demodulation reconstructs the video signal, which is used to modulate the density of print produced by a printing device. This device is scanning in a raster scan synchronised with that at the transmitting terminal. As a result, a facsimile copy of the subject document is produced.

Probably you have uses for this facility in your organisation.

Yours sincerely,

Phil.

P.J. CROSS
Group Leader - Facsimile Research

Registered in England: No. 2038
Registered Office: 60 Vicars Lane, Ilford, Essex.

Replacing the Fitted Plug (UK)

Important

The mains lead for this machine is fitted with a standard (BS 1363) 13 amp plug and has a 13 amp fuse. When you change or examine the fuse, you must re-fit the correct 13 amp fuse. You then need to replace the fuse cover. If you have lost the fuse cover, do not use the plug until you have another fuse cover.

Please contact the people from you purchased the machine.

The 13 amp plug is the most widely used type in the UK and should be suitable.

However, some buildings (mainly old ones) do not have normal 13 amp plug sockets. You need to buy a suitable plug adaptor. Do not remove the moulded plug.

Warning

If you cut off the moulded plug, get rid of it straight away.
You cannot rewire the plug and you may receive an electric shock
if you plug it into a socket.

Important warning: You must earth this machine.

The wires in the mains lead have the following colour code:

- Green and Yellow: Earth
- Blue: Neutral
- Brown: Live

If the wires in the mains lead do not match the colours marked in your plug, do the following:

You must connect the green and yellow wire to the pin marked by the letter 'E', or by the safety 'Earth symbol' or coloured green and yellow or green.

You must connect the blue wire to the pin which is marked with the letter 'N' or coloured black.

You must connect the brown wire to the pin which is marked with the letter 'L' or coloured red.

You must have a 13 amp fuse in the plug, adaptor, or at the distribution board.



Notes For Use of This Device (New Zealand)

The grant of a Telepermit for any item of terminal equipment indicates only that Telecom has accepted that the item complies with minimum conditions for connection to its network. It indicates no endorsement of the product by Telecom, nor does it provide any sort of warranty. Above all, it provides no assurance that any item will work correctly in all respects with another item of Telepermitted equipment of a different make or model, nor does it imply that any product is compatible with all of Telecom's network services.

This equipment shall not be set up to make automatic calls to the Telecom '111' Emergency Service.

This equipment may not provide for the effective hand-over of a call to another device connected to the same line.

Important Notice

Under power failure conditions, this telephone may not operate. Please ensure that a separate telephone, not dependent on local power, is available for emergency use.

Declaration of Conformity (European Countries)

Approvals and Certifications



The CE marking applied to this product symbolises Samsung Electronics Co., Ltd. Declaration of Conformity with the following applicable 93/68/EEC Directives of the European Union as of the dates indicated:

January 1, 1995: Council Directive 73/23/EEC Approximation of the laws of the member states related to low voltage equipment.

January 1, 1996: Council Directive 89/336/EEC (92/31/EEC), approximation of the laws of the Member States related to electromagnetic compatibility.

March 9, 1999: Council Directive 1999/5/EC on radio equipment and telecommunications terminal equipment and the mutual recognition of their conformity.

A full declaration, defining the relevant Directives and referenced standards can be obtained from your Samsung Electronics Co., Ltd. representative.

EC Certification

Certification to 1999/5/EC Radio Equipment & Telecommunications Terminal Equipment Directive (FAX)

This Samsung product has been self-certified by Samsung for pan-European single terminal connection to the analogue public switched telephone network (PSTN) in accordance with Directive 1999/5/EC. The product has been designed to work with the national PSTNs and compatible PBXs of the European countries:

In the event of problems, you should contact the Euro QA Lab of Samsung Electronics Co., Ltd. in the first instance.

The product has been tested against TBR21 and TBR 38. To assist in the use and application of terminal equipment which complies with this standard, the European Telecommunication Standards Institute (ETSI) has issued an advisory document (EG 201 121) which contains notes and additional requirements to ensure network compatibility of TBR21 terminals. The product has been designed against, and is fully compliant with, all of the relevant advisory notes contained in this document.



Fax Branding (US)

The Telephone Consumer Protection Act of 1991 makes it unlawful for any person to use a computer or other electronic device to send any message via a telephone facsimile machine unless such message clearly contains in a margin at the top or bottom of each transmitted page or on the first page of the transmission the following information:

- the date and time of transmission
- identification of either business, business entity or individual sending the message; and
- telephone number of either the sending machine, business, business entity or individual.

See "Setting Fax Number and Name" on page 1.36 for instructions on how to enter this information into your Samsung FAX machine's memory.

The Telephone Company may make changes in its communications facilities, equipment operations, or procedures where such action is reasonably required in the operation of its business and is not inconsistent with the rules and regulations in FCC Part 68. If such changes can be reasonably expected to render any customer terminal equipment incompatible with telephone company communications facilities, or require modification or alteration of such terminal equipment, or otherwise materially affect its use or performance, the customer shall be given adequate notice in writing, to allow the customer an opportunity to maintain uninterrupted service.

Telephone Company Information (US)

FCC IDENTIFICATION NUMBER

The Ringer Equivalence Number and FCC Registration Number for this equipment may be found on the label located on the bottom or rear of the machine. In some instances you may need to provide these numbers to the telephone company.

RINGER EQUIVALENCE NUMBER

The Ringer Equivalence Number (REN) is a measure of the electrical load placed on the telephone line, and is useful for determining whether you have "overloaded" the line. Installing several types of equipment on the same telephone line may result in problems making and receiving telephone calls, especially ringing when your line is called. The sum of all Ringer Equivalence Numbers of the equipment on your

telephone line should be less than five in order to assure proper service from the telephone company. In some cases, a sum of five may not be usable on your line. If any of your telephone equipment is not operating properly, you should immediately remove it from your telephone line, as it may cause harm to the telephone network.

WARNING:

FCC Regulations state that changes or modifications to this equipment not expressly approved by the manufacturer could void the user's authority to operate this equipment.

In the event that terminal equipment causes harm to the telephone network, the telephone company should notify the customer that service may be stopped. However, where prior notice is impractical, the company may temporarily cease service, providing that they:

- a) Promptly notify the customer.
- b) Give the customer an opportunity to correct the equipment problem.
- c) Inform the customer of the right to bring a complaint to the Federal Communication Commission pursuant to procedures set out in FCC Rules and Regulations Subpart E of Part 68.

You should also know that:

- Your Samsung FAX machine is not designed to be connected to a digital PBX system.
- Special features, such as "Call Waiting", may interrupt FAX service, and we suggest that these services not be installed on the FAX line.
- If you intend to use a computer modem or fax modem on the same phone line as your FAX machine, you may experience transmission and reception problems with all the equipment. It is recommended that no other equipment, except for a regular telephone, share the line with your FAX machine.
- If your area experiences a high incidence of lightning or power surges, we recommend that you install surge protectors for both the power and the telephone lines. Surge protectors can be purchased from your dealer or telephone and electronic specialty stores.
- When programming emergency numbers and/or making test calls to emergency numbers, use a non-emergency number to advise the emergency service dispatcher of your intentions. The dispatcher will give you further instructions on how to actually test the emergency number.
- This equipment may not be used on coin service or party lines.
- This telephone provides magnetic coupling to hearing aids.
- You may safely connect this equipment to the telephone network by means of a standard modular jack, USOC RJ-11C.



INDEX

A

AC power 1.10
ADF, load 3.4
alignment, cartridges 6.15
automatic dial 5.20

B

black copy 1.5, 3.7
black fax 1.6, 5.7
booklet, print 2.11
broadcasting 5.28

C

caller ID 5.40, 5.45
cancel
 copy 3.8
 fax 5.7
 print 2.7
 scan 4.5
 scheduled fax 5.38
cartridge
 align 6.15
 clean 6.3
 install 1.13
 maintain 6.2
 replace 6.9
 type 6.10
cartridge holder
 clean 6.8
 location 1.3
character, enter 1.37
clean
 cartridge 6.3
 cartridge contacts 6.8
 nozzle 6.6
clock mode 1.35
clone, special copy 3.12
collate, copy 3.10
colour copy 1.5, 3.7
colour fax 5.7, 5.17

copy

contrast 3.9
page 3.9
quality 3.8
size 3.10
special option 3.11

D

date and time, set 1.33
date format, change 1.35
default setting
 copy 3.15
 fax 5.6
delayed fax 5.30
dial mode, set 1.42
document
 jam, clear 7.2
 load in ADF 3.4
 load on the document glass 3.5
 type setting from PC 2.10
document glass
 clean 6.20
 load, document 3.5
DRPD
 receive fax 5.17
 setup 5.44

E

envelope, load 2.4
error message 7.7

F

fax
 forward 5.18
 option 5.41
 receive 5.13
 send 5.2
fax gate, configure 1.24
fit to page, special copy 3.12

G

group dial 5.24

H

handout, print 2.13

I

ink level, view

from control program 2.18

from operation panel 6.3

ink save 1.43

install

cartridges 1.13

software 1.18

system requirement 1.19

internet gate, configure 1.24

J

jam, clear 7.4

junk fax 5.46

K

key sound, set 1.41

L

language, change 1.39

M

memory, clear 6.18

MFP driver

install 1.20

uninstall 1.28

mirror, special copy 3.14

N

nozzle, clean 6.6

O

one-touch dial 5.20

operation panel 1.5

orientation, print 2.10

P

paper

guideline 2.2

jam 7.4

load 1.11

paper save 1.43

paper size

set for copy 3.2

set for fax 5.42

set for PC print 2.10

paper type

select 2.2

set for copy 3.3

set for PC print 2.10

parallel, connection 1.9

pause 1.38

photo cartridge 6.9

PIN 3.16

polling 5.34

poster

copy 3.13

print 2.12

power save 1.44

print cartridge

align 6.15

clean 6.3

install 1.13

maintain 6.2

replace 6.9

type 6.10

print driver

install 1.20

remove 1.28

print quality 2.10

print setting

access 2.8

properties 2.9

printer control program 2.17

priority fax 5.32

Q

quality

copy 3.8

fax 5.4

print 2.10

R

- receive mode, fax 5.13
- redial
 - count 5.43
 - interval 5.43
- remote test 6.19
- reports, print 5.39
- resolution
 - fax 5.4
 - print 2.10
- reverse page order 2.10
- ringer volume 1.41

S

- save
 - ink 1.43
 - paper 1.43
 - power 1.44
- scan driver
 - install 1.20
 - remove 1.28
- scan monitor 4.2
- search memory 5.26
- SmarThru
 - install 1.20

- uninstall 1.28

- speaker volume 1.41
- special paper, load 2.4
- speed dial 5.22
- system data, set 5.41

T

- toll save fax 5.11
- TWAIN, scan 4.6
- two-sided print 2.13

U

- uninstall 1.28
- USB
 - connect 1.9
 - mode change 7.12

W

- web smoothing 2.10

Z

- zoom rate 3.10





Home

Visit us at:
<http://www.samsungelectronics.com/mfp>

P/N: JB68-00696A Rev. 1.00