

EMI TEST REPORT

FCC Part 15 Subpart B, Class B

Product : Multi Function Peripheral
Model No. : SCX-1150F

JOB NO. : KE-01-590

1. This test reports shall not be reproduced except in full, without the written approval of SEC EMC Testing laboratory.
2. This test reports does not constitute an endorsement by NIST/NVLAP or U.S Government.
3. This test report is to certify that the tested device properly complies with the requirements of FCC Rules and Regulations Part 15 Subpart B Unintentional Radiators.
All tests necessary to show compliance to the requirements were and these results met the specifications requirement.

Date of test : December 3, 2001

Issued Date : December 11, 2001

Prepared by:

Min Gon, KIM / Test Engineer

Reviewed by:

Chun Kil, KIM / Technical Manager

Authorised by:

Yang Su, KIM / Quality Manager

This laboratory is registered by the NIST/NVLAP, U.S.A.
The test reported herein have been performed in accordance
with its terms of registration.

NVLAP[®]

LAB CODE : 200447-0

Table of Contents

1. General Information

- 1.1 Product Description
- 1.2 Tested System Details
- 1.3 Test Methodology
- 1.4 Test Facility

2. System Test Configuration

- 2.1 Operation Environment
- 2.2 Justification
- 2.3 EUT Exercise Software
- 2.4 Test Procedure
- 2.5 Test System configuration

3. Conducted and Radiated Measurement Photos

- 3.1 Conducted Measurement Photos
- 3.2 Radiated Measurement Photos

4. Measurement Uncertainty

- 4.1 Conducted Emission Test
- 4.2 Radiated Emission Test

5. Conducted Emission Test Data

6. Radiated Emission Test Data

7. Label and Label Location

8. Test Equipment Used

1. General Information

APPLICANT : SAMSUNG ELECTRONICS CO., LTD.

ADDRESS : 416, Maetan-3Dong, Paldal-Gu
Suwon-City, Kyungki-Do, Korea 442-742

CONTACT PERSON : Ju Tak, Yang
TEL. +82-31-200-4113

CONTACT ADDRESS : 416, Maetan-3Dong, Paldal-Gu
Suwon-City, Kyungki-Do, Korea 442-742

REGULATION(S) : FCC Part 15 Subpart B, Class B

MODEL NUMBER : SCX-1150F

SERIAL NUMBER : -

VARIANT NAME(S) : -

TESTED DATE : December 3, 2001

TEST SITE : 3meter semi-anechoic chamber

TEST SITE ADDRESS : San 14, Nongseo-Ri, Kihung-Eup,
Yongin-City, Kyungki-Do, Korea, 449-900

1.1 Product Description

The Samsung MFP, SCX-1150F is supporting the ADF Copy, fax Tx,Rx and PC Printing, ADF Scan through IEEE1284,USB port, and it have phone call handset so talk to each other through PSTN.

Main System clock 66MHz, Image Processor clock 75MHz, USB clock 48MHz and Modem clock 28MHz.

See the attached SCX-1150F User's Guide for more information.

1.2 Tested System Details

The FCC IDs for all equipment, plus descriptions of all cables used in the tested system are:

Model	FCC ID/DoC	Description	Cable description
(1) Samsung Electronics M/N : SCX-1150F S/N : - (EUT)	A3LSCX1150F	MFP	Unshielded RJ11 cable Unshielded AC power cable Centronics USB
(2) Samsung Electronics M/N : SyncMaster 17GLSi S/N : P106H2JN401141	A3LCMH737	Monitor	Shielded Signal Cable Unshielded AC power cable
(3) Samsung Electronics M/N : TD260-DT S/N : C92DK409981	DOC	Computer	Unshielded AC power cable
(4) Compaq M/N : RT6656TW S/N : 23N39D015196	AQ6-MTN4XZ15	KeyBoard	PS/2
(5) SEJIN M/N : SMB-600 S/N : 6GAF00761	GJJB50PA0	Mouse	PS/2
(6) US Robotics M/N : SPORTSTER S/N : 33083962	DOC	Ext. Modem	Serial Cable
(7) Samsung M/N : SP-F124 S/N : KKC614776	Verification	Ext. Telephone	Telephone Cable

1.3 Test Methodology

Both conducted and radiated testing were performed according to the procedures in FCC/ANSI C63.4(1992).

Radiated testing was performed at a distance of 3 meters from the antenna to EUT.

1.4 Test Facility

All test described in this report were performed by :

Open area test site : 781-14, Chung-Ri, Dongtan-Myun, Hwasung-Kun, Kyungki-Do, Korea
Conducted measurement facility and 3meter Semi-anechoic chamber :
San 14, Nongseo-Ri, Kihung-Eup, Yongin-City, Kyungki-Do, Korea, 449-900

2. System Test Configuration

2.1 Operation Environment

	Conduction	Radiation
Temperature [] :	22	22
Humidity [%] :	30	30
Power supply :	AC110V-240V, 50/60Hz	AC110V-240V, 50/60Hz

2.2 Justification

The system was configured in typical fashion(as a customer would normally use it) for testing.

2.3 EUT Exercise Soft ware

It used Hun2000 word processor to PC printing.
 Word processor excuted 'H' character documant continuously.

2.4 Test Procedure

2.4.1 Conducted Emissions

EUT was placed on a platform of nominal size, 1m by 1.5m, raised 80cm above the conducting ground plane. The rear of tabletop was located 40cm to the vertical conducting ground plane.

The rear of EUT, including peripherals was aligned and flush with rear of tabletop. All other surfaces of tabletop was at least 80cm from any other grounded conducting surface. I/O cables and AC cables that were connected to the peripherals were bundled in center. They were folded back and forth forming a bundle 30cm to 40cm long and were hanged at a 40cm height to the ground plane.

Each EUT current-carrying power lead, except the ground(safety) lead, were individually connected through a LISN to the input power source.

All unused 50 ohm connectors of the LISN were resistively terminated in 50 ohm when not connected to the measuring equipment.

2.4.2 Radiated Emissions

EUT was placed on a platform of nominal size, 1m by 1.5m, raised 80cm above the conducting ground plane.

The rear of EUT, including peripherals was aligned and flush with rear of tabletop.

I/O cables that were connected to the peripherals were bundle in center.

They were folded back and forth forming a bundle 30cm to 40cm long and were hanged 40cm height to the ground plane.

Test was made with the antenna positioned in both the horizontal and vertical planes of polarization. The measurement antenna was varied in height above the conducting ground plane to obtain the maximum signal strength.

2.5 Test System configuration

2.5.1 System Block Diagram of Test Configuration

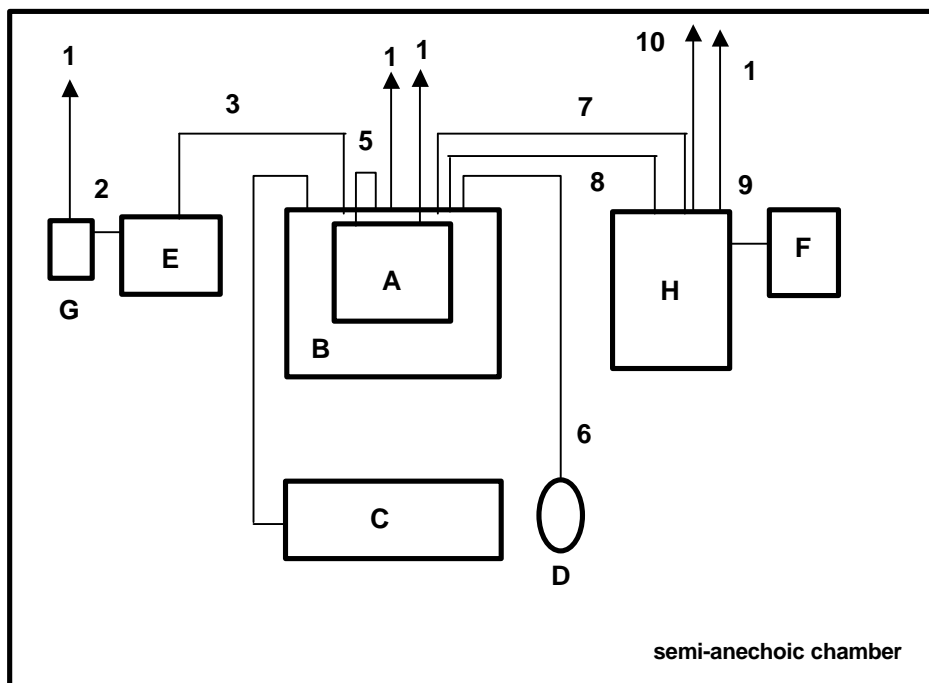

2.5.2 Configuration of EUT and peripherals

Mark	Item	Model No.	Serial No.	Manufacturer	Remark
A	Monitor	SyncMaster 17GLSi	P106H2JN401141	Samsung	
B	Computer	TD260-DT	C92DK409981	Samsung	
C	KeyBoard	RT6656TW	23N39D015196	compaq	
D	Mouse	SMB-600	6GAF007601	Sejin	
E	Ext. Modem	SPORTSTER	33083962	US Robotics	
F	Ext. Telephone	SP-F124	KKCN614776	Samsung	
G	Adaptor	AW-1220A	-	Anjun	
H	MFP	SCX-1150F	-	Samsung	EUT

2.5.3 Used Cable Description

No.	Item	Length[m]	Shielded(Y/N)	Remark
1	AC Power cable	1.7	N	
2	DC Power cable	1.5	N	
3	Serial cable	1.5	Y	
4	KeyBoard Cable	1.8	N	PS/2
5	Monitor Cable	1.8	Y	D-sub
6	Mouse Cable	1.8	N	PS/2
7	Centronics Cable	1.5	Y	IEEE1284
8	USB Cable	1.5	N	
9	Telephone Cable	1.5	N	RJ11
10	Telephone Cable	2	N	Connect to PSTN

4. Measurement Uncertainty

All data in report are to be traceability to the national or international standards.

4.1 Conducted Emission Test

The measurement uncertainty(with a 95% confidence level)for this test was $\pm 2.2\text{dB}$.

The data listed in this test report may exceed the test limit because it does not have enough margin(more than 2.0dB).

The data listed in this test report has enough margin, more than 2.0dB.

4.2 Radiated Emission Test

The measurement uncertainty(with a 95% confidence level)for this test was $\pm 3.4\text{dB}$.

The data listed in this test report may exceed the test limit because it does not have enough margin(more than 2.0dB).

The data listed in this test report has enough margin, more than 3.4dB.

5. Conducted Emission Test Data

The initial step in collecting conducted data was to perform a quasi-peak scan over the measurement range using a spectrum analyzer.

During between calling and connecting on internet, quasi-peak level was investigated and the worst-case emission are reported.

All other emission are non-significant.

The minimum margin to the limit is as follows :

Frequency : 0.658 [MHz]
 Meter Reading : 41.1 [dBuV]
 LISN Loss : 0.07 [dB]
 Cable loss : 0.4 [dB]
 Corrected Readings : 41.57 [dBuV/m]
 Margin : -6.39 [dB]

Test Data Sheet

Tested Frequency [MHz]	Meter Reading [A] [dBuV]	LISN Pol. [L1/L2]	Factor[B]		Corrected Reading [A+B] [dBuV/m]	Limits [dBuV/m]	Margin [dB]
			LISN Loss [dB]	Cable Loss			
0.599	37.12	H	0.07	0.50	37.69	47.96	-10.27
0.611	37.92	N	0.07	0.50	38.49	47.96	-9.47
0.658	41.1	N	0.07	0.40	41.57	47.96	-6.39
0.670	35.55	H	0.07	0.40	36.02	47.96	-11.94
0.720	37.23	N	0.07	0.40	37.70	47.96	-10.26
0.740	36.11	N	0.07	0.40	36.58	47.96	-11.38
0.865	35.12	N	0.08	0.40	35.60	47.96	-12.36
0.892	36.35	H	0.08	0.40	36.83	47.96	-11.13
0.947	37.8	N	0.08	0.40	38.28	47.96	-9.68

- * All readings are quasi-peak mode.
- * The selected bandwidth in emission testing is 9kHz.
- * Results = Meter Reading + LISN Insertion loss + Cable loss
- * Margin = Corrected Reading - Limits
- * H = Hot, N = Neutral

6. Radiated Emission Test Data

The initial step in collecting conducted data was to perform a quasi-peak scan over the measurement range using a spectrum analyzer.

During between calling and connecting on internet, quasi-peak level was investigated and the worst-case emission are reported.

All other emission are non-significant.

The minimum margin to the limit is as follows :

Frequency : **33.90** [MHz]
 Meter Reading : **17.4** [dBuV]
 Antenna Factor : **17.10** [dB]
 Cable loss : **0.10** [dB]
 Corrected Reading : **34.6** [dBuV/m]
 Margin : **-5.40** [dB]

Test Data Sheet

Frequency Range [MHz]	Tested Frequency [MHz]	Ant. Pol.	Meter Reading [A] [dBuV]	Factor[B]		Antenna Height [Cm]	Turn table Degree [Deg]	Corrected Reading [A+B] [dBuV/m]	Margin [dB]	Limits [3m] [dBuV/m]
				Ant. Factor	Cable Loss					
				[dB]						
30 - 88	31.29	V	12.5	18.80	0.10	135	180	31.4	-8.60	40.0
	33.90	V	17.4	17.10	0.10	100	220	34.6	-5.40	
	44.60	H	15.2	11.30	0.10	100	175	26.6	-13.40	
88 - 216	147.30	H	18.7	7.70	0.90	150	0	27.3	-16.20	43.5
	156.50	H	22.4	7.50	0.95	120	180	30.9	-12.65	
216 - 960	295.45	H	24.8	10.80	1.58	220	10	37.2	-8.82	46.0
	296.12	H	25.7	10.80	1.58	150	110	38.1	-7.92	
	448.60	V	21.3	14.50	2.20	240	130	38.0	-8.00	
	507.40	V	21.4	15.60	2.52	110	0	39.5	-6.48	
	599.80	H	11.5	17.00	2.80	230	130	31.3	-14.70	
960 -1000									54.0	

* "<" Means equal or less than * All readings are quasi-peak mode.

* The selected bandwidth in emission testing is 100kHz.

* Corrected Reading = Meter Reading + Antenna Factor + Cable loss

* Margin = Corrected Reading - Limits

* H = Horizontal Polarization/Antenna, V = Vertical Polarization/Antenna

8. Test Equipment Used

Equipment	Model No.	Serial No.	Makers	Last calibration and Interval
Spectrum analyzer	8568B	2928A04826	H.P	01/07/26, 12Months
		Firmware versions : REV 7.4.87		
Quasi-peak adapter	85650A	2811A01342	H.P	01/09/10, 12Months
RF Preselector	85685A	2926A01005	H.P	01/07/26, 12Months
EMI Test Receiver	ESCS30	8309861004	R & S	01/01/06, 12Months
		F/W ver. : Main 3.10, OTP 02.01, GRA 02.03		
L.I.S.N	ESH2-Z5	831886/0006	R & S	01/11/20, 12Months
	3825/2	8909-1548	EMCO	01/11/08, 12Months
Biconilog Antenna	HL 562	361324/003	R & S	01/01/22, 12Months
EMI Measurement Software	HP	Firmware versions : Rev. A.00.00		