



**FCC CFR47 PART 22 SUBPART H
FCC CFR47 PART 24 SUBPART E
FCC CFR47 PART 27 SUBPART F, H and M
FCC CFR47 PART 90 SUBPART S**

CERTIFICATION TEST REPORT

FOR

GSM/WCDMA/LTE Phone + BT/BLE, DTS/UNII a/b/g/n/ac, NFC and ANT+

MODEL NUMBER: SCV32

FCC ID: A3LSCV32

REPORT NUMBER: 15I21858-E1V4

ISSUE DATE: NOVEMBER 19, 2015

Prepared for

**SAMSUNG ELECTRONICS CO., LTD.
129 SAMSUNG-RO, YEONGTONG-GU, SUWON-SI,
GYEONGGI-DO, 443-742, KOREA**

Prepared by

**UL VERIFICATION SERVICES
47173 BENICIA STREET
FREMONT, CA 94538, U.S.A.
TEL: (510) 771-1000
FAX: (510) 661-0888**

Revision History

Rev.	Date	Revisions	Revised By
V1	11/11/15	Initial Issue	P. Zhang
V2	11/12/15	Revised Section 5.3 page 10.	C. Vergonio
V3	11/13/15	Updated Section 2, 5.3, 6, 8.3.1, 8.3.3, 8.3.5, 10.4.1 and 11.1.3	C. Vergonio
V4	11/19/15	Updated page 142.	C. Vergonio

TABLE OF CONTENTS

1.	ATTESTATION OF TEST RESULTS	5
2.	TEST METHODOLOGY	6
3.	FACILITIES AND ACCREDITATION	6
4.	CALIBRATION AND UNCERTAINTY	7
4.1.	<i>MEASURING INSTRUMENT CALIBRATION</i>	<i>7</i>
4.2.	<i>SAMPLE CALCULATION</i>	<i>7</i>
4.3.	<i>MEASUREMENT UNCERTAINTY</i>	<i>7</i>
5.	EQUIPMENT UNDER TEST	8
5.1.	<i>DESCRIPTION OF EUT</i>	<i>8</i>
5.2.	<i>MAXIMUM OUTPUT POWER.....</i>	<i>8</i>
5.3.	<i>MAXIMUM OUTPUT POWER (LTE).....</i>	<i>9</i>
5.4.	<i>DESCRIPTION OF AVAILABLE ANTENNAS</i>	<i>12</i>
5.5.	<i>DESCRIPTION OF TEST SETUP.....</i>	<i>13</i>
6.	TEST AND MEASUREMENT EQUIPMENT	16
7.	SUMMARY TABLE	17
8.	RF POWER OUTPUT VERIFICATION.....	18
8.1.	<i>GSM/GPRS/EDGE</i>	<i>18</i>
8.1.1.	<i>GSM OUTPUT POWER RESULT</i>	<i>19</i>
8.2.	<i>UMTS REL 99.....</i>	<i>20</i>
8.2.1.	<i>UMTS REL 99 OUTPUT POWER RESULT</i>	<i>20</i>
8.3.	<i>UMTS HSDPA</i>	<i>21</i>
8.3.1.	<i>UMTS HSDPA OUTPUT POWER RESULT.....</i>	<i>21</i>
8.3.2.	<i>UMTS HSUPA</i>	<i>22</i>
8.3.3.	<i>UMTS HSUPA OUTPUT POWER RESULT.....</i>	<i>23</i>
8.3.4.	<i>LTE OUTPUT VERIFICATION.....</i>	<i>24</i>
8.3.5.	<i>LTE OUTPUT RESULT</i>	<i>24</i>
9.	PEAK TO AVERAGE RATIO	40
9.1.	<i>CONDUCTED PEAK TO AVERAGE RESULT.....</i>	<i>40</i>
10.	LIMITS AND CONDUCTED RESULTS.....	52

10.1. OCCUPIED BANDWIDTH.....52
10.1.1. OCCUPIED BANDWIDTH RESULTS.....53
10.1.2. LTE OCCUPIED BANDWIDTH RESULTS54
10.1.1. OCCUPIED BANDWIDTH PLOTS59
10.2. BAND EDGE EMISSIONS69
10.2.1. BAND EDGE PLOTS70
10.2.2. EMISSION MASK PLOTS107
10.3. OUT OF BAND EMISSIONS119
10.3.1. OUT OF BAND EMISSIONS RESULT120
10.3.2. OUT OF BAND EMISSIONS PLOTS.....126
10.4. FREQUENCY STABILITY136
11. RADIATED TEST RESULTS142
11.1. RADIATED POWER (ERP & EIRP).....142
11.1.1. ERP/EIRP143
11.1.2. LTE ERP/EIRP144
11.1.3. ERP/EIRP PLOTS.....148
11.2. FIELD STRENGTH OF SPURIOUS RADIATION188
11.2.1. SPURIOUS RADIATION PLOTS.....190
12. SETUP PHOTOS230

1. ATTESTATION OF TEST RESULTS

COMPANY NAME: SAMSUNG ELECTRONICS CO., LTD.
EUT DESCRIPTION: GSM/WCDMA/LTE Phone + BT/BLE, DTS/UNII a/b/g/n/ac, NFC and ANT+
MODEL: SCV32
SERIAL NUMBER: 2215408 (Radiated), 2215407 (Conducted)
DATE TESTED: SEPTEMBER 30 – OCTOBER 29, 2015

APPLICABLE STANDARDS	
STANDARD	TEST RESULTS
FCC PART 22H, 24E, 27F, 27H, 27M and 90S	PASS

UL Verification Services Inc. tested the above equipment in accordance with the requirements set forth in the above standards. All indications of Pass/Fail in this report are opinions expressed by UL Verification Services Inc. based on interpretations and/or observations of test results. Measurement Uncertainties were not taken into account and are published for informational purposes only. The test results show that the equipment tested is capable of demonstrating compliance with the requirements as documented in this report.

Note: The results documented in this report apply only to the tested sample, under the conditions and modes of operation as described herein. This document may not be altered or revised in any way unless done so by UL Verification Services Inc. and all revisions are duly noted in the revisions section. Any alteration of this document not carried out by UL Verification Services Inc. will constitute fraud and shall nullify the document. This report must not be used by the client to claim product certification, approval, or endorsement by NVLAP, NIST, any agency of the Federal Government, or any agency of any government.

Approved & Released For
UL Verification Services Inc. By:



PENG ZHANG
CONSUMER TECHNOLOGY DIVISION
PROJECT LEAD
UL Verification Services Inc.

Tested By:



R.ALEGRE
CONSUMER TECHNOLOGY DIVISION
LAB ENGINEER
UL Verification Services Inc.

2. TEST METHODOLOGY

The tests documented in this report were performed in accordance with TIA-603-D, FCC CFR 47 Part 22, FCC CFR Part 24, FCC CFR 47 Part 27, and FCC CFR 47 Part 90.

3. FACILITIES AND ACCREDITATION

The test sites and measurement facilities used to collect data are located at 47173 and 47266 Benicia Street, Fremont, California, USA. Line conducted emissions are measured only at the 47173 address. The following table identifies which facilities were utilized for radiated emission measurements documented in this report. Specific facilities are also identified in the test results sections.

47173 Benicia Street	47266 Benicia Street
<input type="checkbox"/> Chamber A(IC: 2324B-1)	<input type="checkbox"/> Chamber D(IC: 2324B-4)
<input checked="" type="checkbox"/> Chamber B(IC: 2324B-2)	<input type="checkbox"/> Chamber E(IC: 2324B-5)
<input checked="" type="checkbox"/> Chamber C(IC: 2324B-3)	<input type="checkbox"/> Chamber F(IC: 2324B-6)
	<input type="checkbox"/> Chamber G(IC: 2324B-7)
	<input type="checkbox"/> Chamber H(IC: 2324B-8)

UL Verification Services Inc. is accredited by NVLAP, Laboratory Code 200065-0. The full scope of accreditation can be viewed at <http://ts.nist.gov/standards/scopes/2000650.htm>.

4. CALIBRATION AND UNCERTAINTY

4.1. MEASURING INSTRUMENT CALIBRATION

The measuring equipment utilized to perform the tests documented in this report has been calibrated in accordance with the manufacturer's recommendations, and is traceable to recognized national standards

4.2. SAMPLE CALCULATION

Where relevant, the following sample calculation is provided:

$EIRP = \text{PSA reading with EUT worst orientation (dBm)} + \text{Path loss (dB)} - \text{cable loss (between the SG and substitution antenna)} + \text{Substitution Antenna Factor (dBi)}$

$ERP = \text{PSA reading with EUT worst orientation (dBm)} + \text{Path loss (dB)} - \text{cable loss (between the SG and substitution antenna)}$

(Path loss = Signal generator output – PSA reading with substitution antenna)

4.3. MEASUREMENT UNCERTAINTY

Where relevant, the following measurement uncertainty levels have been estimated for tests performed on the apparatus:

PARAMETER	UNCERTAINTY
Conducted Disturbance, 0.15 to 30 MHz	3.52 dB
Radiated Disturbance, 30 to 1000 MHz	4.94 dB
Radiated Disturbance, 1GHz to 40GHz	4.94 dB

Uncertainty figures are valid to a confidence level of 95%.

5. EQUIPMENT UNDER TEST

5.1. DESCRIPTION OF EUT

This EUT is a GSM/WCDMA/LTE Phone + BT/BLE, DTS/UNII a/b/g/n/ac, NFC and ANT+.

5.2. MAXIMUM OUTPUT POWER

The transmitter has a maximum peak conducted and radiated ERP / EIRP output powers as follows:

FCC Part 22/24						
Band	Frequency Range(MHz)	Modulation	Conducted		Radiated	
			AVG(dBm)	AVG(mW)	AVG(dBm)	AVG(mW)
GSM850	824~849	GPRS	32.9	1949.8445	29.74	941.89
	824~849	EGPRS	27.0	501.19	23.70	234.42
GSM1900	1850~1910	GPRS	29.2	831.76	29.97	993.12
	1850~1910	EGPRS	26.3	426.58	25.82	381.94
Band 5	824~849	Rel99	22.9	194.984	19.21	83.37
	824~849	HSDPA	22.5	177.83	19.26	84.33
	824~849	HSUPA	22.5	177.83		

5.3. MAXIMUM OUTPUT POWER (LTE)

The transmitter has a maximum peak conducted and radiated ERP/EIRP output powers as follows:

FCC Part 27							
Band	Frequency Range(MHz)	BandWidth (MHz)	Modulation	Conducted		Radiated	
				AVG(dBm)	AVG(mW)	Peak(dBm)	Peak(mW)
LTE41	2496~2690	20MHz	QPSK	23.10	204.17	22.86	193.20
			16QAM	22.47	176.60	22.26	168.27
		15MHz	QPSK	23.15	206.54	22.58	181.13
			16QAM	22.41	174.18	21.85	153.11
		10MHz	QPSK	23.50	223.87	22.66	184.50
			16QAM	22.78	189.67	22.36	172.19
		5MHz	QPSK	23.50	223.87	22.63	183.23
			16QAM	22.14	163.68	21.84	152.76

FCC Part 90							
Band	Frequency Range(MHz)	BandWidth (MHz)	Modulation	Conducted		Radiated	
				AVG(dBm)	AVG(mW)	Peak(dBm)	Peak(mW)
LTE26	814~824	10MHz	QPSK	23.5	223.87	19.20	83.18
			16QAM	22.4	173.78	18.40	69.18
		5MHz	QPSK	23.4	218.78	19.20	83.18
			16QAM	22.5	177.83	18.60	72.44
		3MHz	QPSK	23.4	218.78	19.57	90.57
			16QAM	22.3	169.82	18.53	71.29
		1.4MHz	QPSK	23.2	208.93	19.79	95.28
			16QAM	22.3	169.82	18.74	74.82

FCC Part 22							
Band	Frequency Range(MHz)	BandWidth (MHz)	Modulation	Conducted		Radiated	
				AVG(dBm)	AVG(mW)	Peak(dBm)	Peak(mW)
LTE26	824~849	15 MHz	QPSK	23.5	223.87	20.20	104.71
			16QAM	22.5	177.83	19.30	85.11
		10MHz	QPSK	23.5	223.87	19.50	89.13
			16QAM	22.5	177.83	18.60	72.44
		5MHz	QPSK	23.5	223.87	19.80	95.50
			16QAM	22.5	177.83	19.20	83.18
		3MHz	QPSK	23.4	218.78	19.81	95.72
			16QAM	22.5	177.83	18.84	76.56
		1.4MHz	QPSK	23.2	208.93	19.88	97.27
			16QAM	22.4	173.78	18.90	77.62

FCC Part 27							
Band	Frequency Range(MHz)	BandWidth (MHz)	Modulation	Conducted		Radiated	
				AVG(dBm)	AVG(mW)	AVG(dBm)	AVG(mW)
LTE17	704~716	5MHz	QPSK	23.3	213.80	16.55	45.19
			16QAM	22.1	162.18	15.4	34.67
		10MHz	QPSK	23.4	218.78	16.50	44.67
			16QAM	22.4	173.78	15.42	34.83

FCC Part 27							
Band	Frequency Range(MHz)	BandWidth (MHz)	Modulation	Conducted		Radiated	
				AVG(dBm)	AVG(mW)	AVG(dBm)	AVG(mW)
LTE13	777~787	5MHz	QPSK	23.1	204.17	16.58	45.50
			16QAM	21.9	154.88	15.59	36.22
		10MHz	QPSK	23.3	213.80	16.62	45.92
			16QAM	22.1	162.18	15.59	36.22

FCC Part 22							
Band	Frequency Range(MHz)	BandWidth (MHz)	Modulation	Conducted		Radiated	
				AVG(dBm)	AVG(mW)	AVG(dBm)	AVG(mW)
LTE5	824~849	1.4MHz	QPSK	23.5	223.87	21.30	134.90
			16QAM	22.5	177.83	20.40	109.65
		3MHz	QPSK	23.5	223.87	21.40	138.04
			16QAM	22.6	181.97	20.60	114.82
		5MHz	QPSK	23.5	223.87	21.60	144.54
			16QAM	22.4	173.78	20.80	120.23
		10MHz	QPSK	23.5	223.87	21.40	138.04
			16QAM	22.6	181.97	20.70	117.49

5.4. DESCRIPTION OF AVAILABLE ANTENNAS

The radio utilizes a PIFA antenna for the [List the bands supported] with a maximum peak gain as follows:

Frequency (MHz)	Peak Gain (dBi)
GSM850, 824~849MHz	-4.36
GSM1900, 1850~1910MHz	-2.57
Band 5, 824~849MHz	-4.36
LTE5, 824~849MHz	-4.36
LTE13, 777~787MHz	-11.1
LTE17, 704~716MHz	-7.42
LTE26, 814~824MHz	-6.68
LTE41, 2496~2690MHz	-3.9

5.5. DESCRIPTION OF TEST SETUP

SUPPORT EQUIPMENT

Support Equipment List				
Description	Manufacturer	Model	Serial Number	FCC ID
AC Adapter	Samsung	ETA0U83KWK	DK1FB05HS	N/A
Earphone	Samsung	N/A	N/A	N/A

I/O CABLES (CONDUCTED SETUP)

I/O Cable List						
Cable No	Port	# of identical ports	Connector Type	Cable Type	Cable Length (m)	Remarks
1	RF Out	1	Spectrum Analyzer	Shielded	None	NA
2	Antenna Port	1	EUT	Shielded	0.1m	NA
3	RF In/Out	1	Communication Test Set	Shielded	1m	NA

I/O CABLES (RADIATED SETUP)

I/O CABLE LIST						
Cable No.	Port	# of Identical Ports	Connector Type	Cable Type	Cable Length	Remarks
1	USB	1	AC Adapter	Un-shielded	1.2m	No
2	Jack	1	Headset	Shielded	1m	No
3	RF In/out	1	Communication Test Set	Un-shielded	2m	Yes

TEST SETUP

The EUT is continuously communicated to the call box during the tests.

SETUP DIAGRAM FOR TESTS (CONDUCTED TEST SETUP)

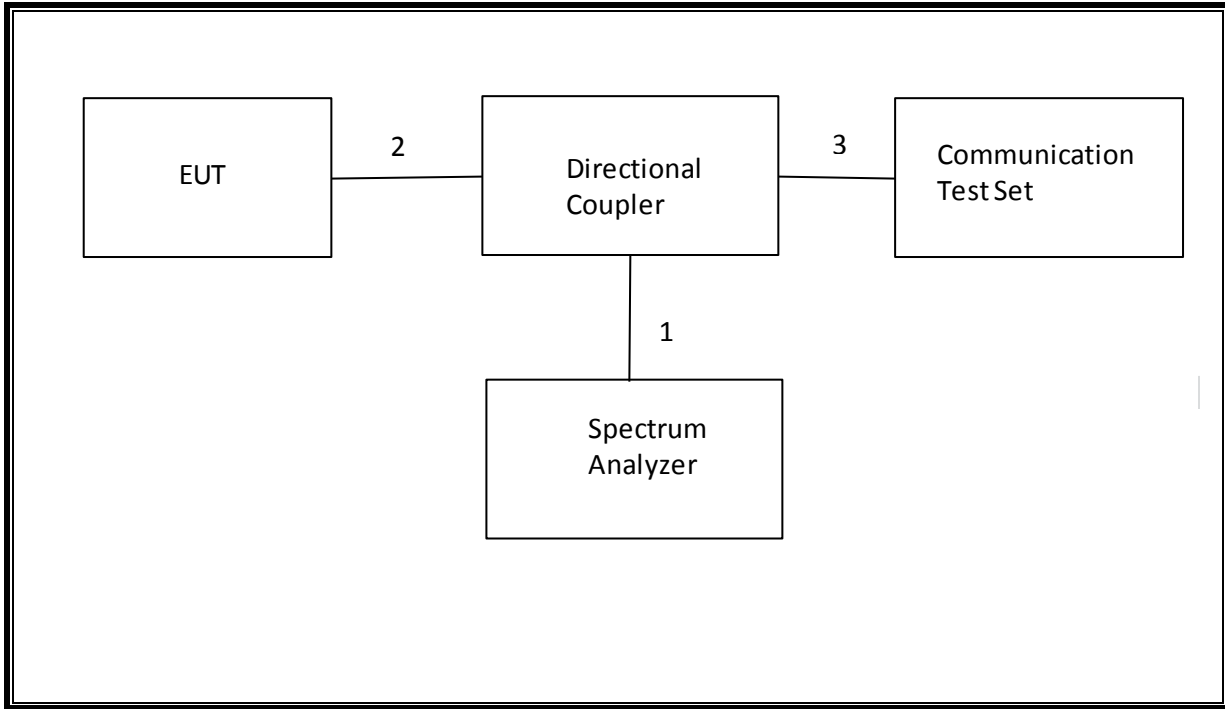

SETUP DIAGRAM FOR TESTS (RADIATED TEST SETUP)

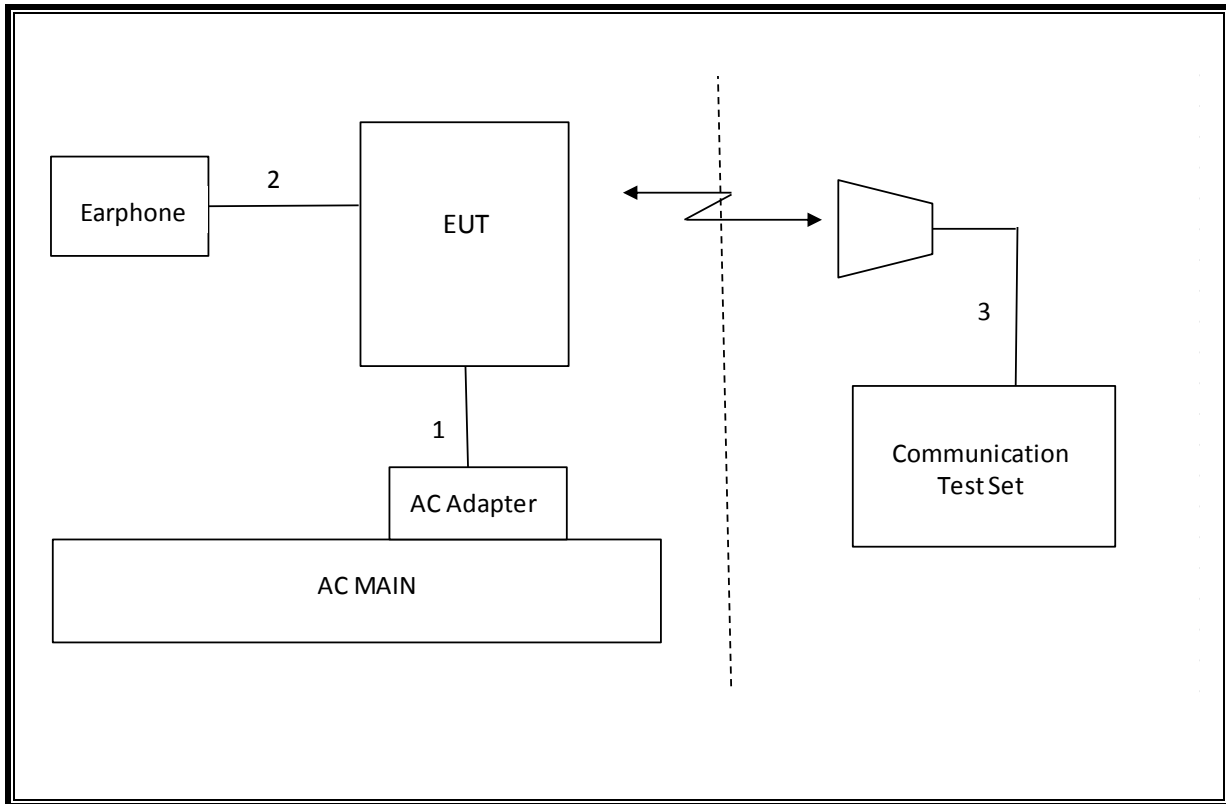

6. TEST AND MEASUREMENT EQUIPMENT

The following test and measurement equipment was utilized for the tests documented in this report:

TEST EQUIPMENT LIST				
Description	Manufacturer	Model	Asset	Cal Due
Spectrum Analyzer, 44 GHz	Agilent / HP	E4446A	146	06/17/16
Antenna, Bilog, 2 GHz	Sunol Sciences	JB1	T243	12/08/15
Antenna, Horn, 18 GHz	EMCO	3115	T60	01/15/16
Highpass Filter, 2.7 GHz	Micro-Tronics	HPM13194	N02687	CNR
Highpass Filter, 1.5 GHz	Micro-Tronics	HPM13193	N02688	CNR
Temperature / Humidity Chamber	Thermotron	SE 600-10-10	C00930	05/12/16
Communications Test Set	R&S	CMW500	T159	07/02/16
DC power supply, 8 V @ 3 A or 15 V	Agilent / HP	E3610A	None	CNR
Vector signal generator, 6 GHz	Agilent / HP	E4438C	None	06/18/16
Antenna, Tuned Dipole 400~1000	ETS	6502	T35	05/15/16
Directional Coupler	RF-Lambda	RFDC5M06G15	None	CNR
Antenna, Horn, 26.5 GHz	ARA	MWH-1826/B	C00589	12/17/15

Test Software List			
Description	Manufacturer	Model	Version
Radiated Software	UL	UL EMC	Version 9.5, 07/22/14
Conducted Software	UL	UL EMC	Version 9.5, 05/17/14
CLT Software	UL	UL RF	Version 1.0, 02/02/15
Antenna Port Software	UL	UL RF	Version 2.1.1.1, 1/20/15

7. SUMMARY TABLE

FCC Part Section	RSS Section(s)	Test Description	Test Limit	Test Condition	Test Result	Note
2.1049	N/A	Occupied Band width (99%)	N/A	Conducted	Pass	17.89MHz
22.917(a) 24.238(a) 27.53(g) 90.691	RSS-132(4.5.1) RSS-133(6.5.1) RSS-139(6.5.1)	Band Edge / Conducted Spurious Emission	-13dBm		Pass	-15.668dBm
27.53(m)	RSS-199(4.5)		-25dBm		Pass	-28.17dBm
2.1046	N/A		Conducted output power		N/A	Pass
27.53(m) 90.691	RSS-199(4.5)	Emission Mask			Pass	Pass
22.355 24.235 27.54 90.213	RSS-132(4.3) RSS-133(6.3) RSS-139(6.3) RSS-199(4.3)	Frequency Stability	2.5PPM		Pass	0.025PPM
22.913(a)(2)	RSS-132(4.4)	Effective Radiated Power	38 dBm	Radiated	Pass	29.74dBm
27.50(c)(10)	N/A		34.77 dBm		Pass	16.55dBm
90.635	N/A		50dBm		Pass	19.79dBm
24.232(c) 27.50(h)(2)	RSS-133(6.4) RSS-199(4.4)	Equivalent Isotropic Radiated Power	33dBm		Pass	29.97dBm
27.50(d)(4)	RSS-139(6.4)		30dBm		Pass	N/A
22.917(a) 24.238(a) 27.53(g)	RSS-132(4.5.1) RSS-133(6.5.1) RSS-139(6.5.1)	Radiated Spurious Emission	-13dBm		Pass	-45.4dBm
27.53(m)	RSS-199(4.5)		-25dBm	Pass	-40.4dBm	

8. RF POWER OUTPUT VERIFICATION

8.1. GSM/GPRS/EDGE

Function: Menu select > GSM Mobile Station > GSM 850/900/1800/1900
Press Connection control to choose the different menus
Press RESET > choose all to reset all settings
Connection Press Signal Off to turn off the signal and change settings
Network Support > GSM+GPRS or GSM+EGPRS
Main Service > Packet Data
Service selection > Test Mode A – Auto Slot Config. off
MS Signal Press Slot Config bottom on the right twice to select and change the number of time slots and power setting
 > Slot configuration > Uplink/Gamma
 > 33 dBm for GPRS 850/900
 > 30 dBm for GPRS1800/1900
BS Signal Enter the same channel number for TCH channel (test channel) and BCCH channel
Frequency Offset > + 0 Hz
Mode > BCCH and TCH
BCCH Level > -85 dBm (May need to adjust if link is not stable)
BCCH Channel > choose desire test channel [Enter the same channel number for TCH channel (test channel) and BCCH channel]
Channel Type > Off
P0> 4 dB
Slot Config > Unchanged (if already set under MS Signal)
TCH > choose desired test channel
Hopping > Off
Main Timeslot > 3 (Default)
Network Coding Scheme > CS4 (GPRS) and MCS5 ~ MCS9 (EGPRS)
 Bit Stream > 2E9-1PSR Bit Pattern
AF/RF Enter appropriate offsets for Ext. Att. Output and Ext. Att. Input
Connection Press Signal On to turn on the signal and change settings

8.1.1. GSM OUTPUT POWER RESULT

Band	Mode	Ch.	f(MHz)	1 time slot	2 time slot	3 time slot	4 time slot
				Peak (dBm)	Peak (dBm)	Peak (dBm)	Peak (dBm)
GSM850	GMSK	128	824.2	32.4			
		190	836.6	33.0			
		251	848.8	32.5			
	GPRS	128	824.2	32.4	29.0	26.5	25.0
		190	836.6	32.9	29.8	27.3	25.5
		251	848.8	32.6	29.2	27.0	25.0
	EGPRS	128	824.2	27.0	24.5	22.3	22.7
		190	836.6	27.0	24.7	22.5	22.9
		251	848.8	27.0	24.5	22.4	22.8
GSM1900	GMSK	512	1850.2	29.3			
		661	1880	29.5			
		810	1909.8	29.4			
	GPRS	512	1850.2	29.2	26.6	24.7	22.8
		661	1880	29.2	26.5	24.5	22.7
		810	1909.8	29.2	26.5	24.6	22.7
	EGPRS	512	1850.2	26.1	23.5	21.8	20.8
		661	1880	26.3	23.5	21.8	20.9
		810	1909.8	26.3	23.5	21.9	20.8

8.2. UMTS REL 99

TEST PROCEDURE

The following summary of these settings are illustrated below:

	Mode	Rel99
	Subtest	-
WCDMA General Settings	Loopback Mode	Test Mode 1
	Rel99 RMC	12.2kbps RMC
	HSDPA FRC	Not Applicable
	HSUPA Test	Not Applicable
	Power Control Algorithm	Algorithm2
	β_c	Not Applicable
	β_d	Not Applicable
	β_{ec}	Not Applicable
	β_c/β_d	8/15
	β_{hs}	Not Applicable
β_{ed}	Not Applicable	

8.2.1. UMTS REL 99 OUTPUT POWER RESULT

Band	Mode	Ch.	f(MHz)	Conducted Power (dBm)
				Avg (dBm)
Band 5	Rel99	4132	826.4	22.9
		4183	836.6	22.8
		4233	846.6	22.8

8.3. UMTS HSDPA

The following 4 Sub-tests were completed according to Release 5 procedures in section 5.2 of 3GPP TS34.121. A summary of these settings are illustrated below:

	Mode	Rel5 HSDPA			
	Subtest	1	2	3	4
WCDMA General Settings	Loopback Mode	Test Mode 1			
	Rel99 RMC	12.2kbps RMC			
	HSDPA FRC	H-Set1			
	Power Control Algorithm	Algorithm 2			
	β_c	2/15	12/15	15/15	15/15
	β_d	15/15	15/15	8/15	4/15
	Bd (SF)	64			
	β_c/β_d	2/15	12/15	15/8	15/4
	β_{hs}	4/15	24/15	30/15	30/15
	MPR (dB)	0	0	0.5	0.5
HSDPA Specific Settings	D_{ACK}	8			
	D_{NAK}	8			
	DCQI	8			
	Ack-Nack repetition factor	3			
	CQI Feedback (Table 5.2B.4)	4ms			
	CQI Repetition Factor (Table 5.2B.4)	2			
	$A_{hs} = \beta_{hs}/\beta_c$	30/15			

8.3.1. UMTS HSDPA OUTPUT POWER RESULT

Band	Mode	Subset	Ch.	f(MHz)	Conducted Power (dBm)
					Avg (dBm)
Band 5	HSDPA	1	4132	826.4	22.5
			4183	836.6	22.5
			4233	846.6	22.5
		2	4132	826.4	21.7
			4183	836.6	21.7
			4233	846.6	21.7
		3	4132	826.4	21.9
			4183	836.6	21.9
			4233	846.6	22.0
		4	4132	826.4	21.9
			4183	836.6	21.8
			4233	846.6	21.7

8.3.2. UMTS HSUPA

TEST PROCEDURE

The following summary of these settings are illustrated below: (ETSI TS 134.121-1 Table C.11.1)

	Mode	Rel6 HSUPA	Rel6 HSUPA	Rel6 HSUPA	Rel6 HSUPA	Rel6 HSUPA
	Subtest	1	2	3	4	5
WCDMA General Settings	Loopback Mode	Test Mode 1				
	P-CPICH (dB)	-10				
	P-CCPCH (dB)	-12				
	SCH (dB)	-12				
	PICH(dB)	-15				
	DPCH (dB)	-9				
	HS-SCCH_1 (dB)	-8				
	HS-PDSCH (dB)	-3				
	Rel99 RMC	12.2kbps RMC				
	HSDPA FRC	H-Set1				
	HSUPA Test	HSUPA Loopback				
	Power Control Algorithm	Algorithm2				
	Bc	11/15	6/15	15/15	2/15	15/15
	Bd	15/15	15/15	9/15	15/15	15/15
	Bec	209/225	12/15	30/15	2/15	5/15
	β_c/β_d	11/15	6/15	15/9	2/15	15/15
	Bhs	22/15	12/15	30/15	4/15	30/15
β_{ed} (note1)	1309/225	94/75	47/15	56/75	134/15	
MPR	0	2	1	2	0	
HSDPA Specific Settings	DACK	8				
	DNAK	8				
	DCQI	8				
	Ack-Nack repetition factor	3				
	CQI Feedback (Table 5.2B.4)	4ms				
	CQI Repetition Factor (Table 5.2B.4)	2				
	Ahs = β_{hs}/β_c	30/15				
HSUPA Specific Settings	D E-DPCCH	6	8	8	5	7
	DHARQ	0	0	0	0	0
	AG Index	20	12	15	17	21
	Reference E-TFCIs	5	5	2	5	5
	ETFCI (from 34.121 Table C.11.1.3)	75	67	92	71	81
	Associated Max UL Data Rate kbps	242.1	174.9	482.8	205.8	308.9
	Reference E_TFCIs	E-TFCI 11 E-TFCI PO 4 E-TFCI 67 E-TFCI PO 18 E-TFCI 71 E-TFCI PO 23 E-TFCI 75 E-TFCI PO 26 E-TFCI 81 E-TFCI PO 27		E-TFCI 11 E-TFCI PO 4 E-TFCI 92 E-TFCI PO 18		E-TFCI 11 E-TFCI PO 4 E-TFCI 67 E-TFCI PO 18 E-TFCI 71 E-TFCI PO 23 E-TFCI 75 E-TFCI PO 26 E-TFCI 81 E-TFCI PO 27

Note1: β_{ed} cannot be set directly, it is set by Absolute Grant Value.

8.3.3. UMTS HSUPA OUTPUT POWER RESULT

Band	Mode	Subset	Ch.	f(MHz)	Conducted Power (dBm)
					Avg (dBm)
Band 5	HSUPA	1	4132	826.4	21.9
			4183	836.6	22.2
			4233	846.6	22.5
		2	4132	826.4	19.9
			4183	836.6	19.5
			4233	846.6	19.5
		3	4132	826.4	21.1
			4183	836.6	21.0
			4233	846.6	21.0
		4	4132	826.4	19.6
			4183	836.6	19.5
			4233	846.6	19.5
		5	4132	826.4	21.6
			4183	836.6	21.3
			4233	846.6	21.3

8.3.4. LTE OUTPUT VERIFICATION

8.3.5. LTE OUTPUT RESULT

Band	BW (MHz)	Mode	RB Allocation	RB offset	Target MPR	Avg Pwr (dBm)				
						39750		40620	41490	
						2506 MHz		2593 MHz	2680 MHz	
LTE Band 41	20	QPSK	1	0	0	22.92		23.05		23.10
			1	49	0	22.86		22.95		23.06
			1	99	0	22.81		22.93		23.01
			50	0	1	21.96		21.78		21.98
			50	24	1	21.98		21.87		22.00
			50	50	1	21.96		21.76		21.87
			100	0	1	21.95		21.76		22.01
		16QAM	1	0	1	22.23		22.47		22.41
			1	49	1	22.22		22.38		22.39
			1	99	1	22.23		22.34		22.30
			50	0	2	20.86		20.74		20.99
			50	24	2	20.85		20.79		20.98
			50	50	2	20.86		20.62		20.87
			100	0	2	20.77		20.73		20.88

Band	BW (MHz)	Mode	RB Allocation	RB offset	Target MPR	Avg Pwr (dBm)				
						39725		40620		41515
						2503.5 MHz		2593 MHz		2682.5 MHz
LTE Band 41	15	QPSK	1	0	0	23.15		22.91		23.03
			1	37	0	23.04		22.88		23.07
			1	74	0	23.00		22.74		22.90
			36	0	1	22.02		21.87		22.06
			36	20	1	22.04		21.85		22.06
			36	39	1	21.97		21.77		21.96
			75	0	1	22.02		21.74		21.98
		16QAM	1	0	1	21.90		22.40		22.05
			1	37	1	21.80		22.41		22.08
			1	74	1	21.73		22.25		21.90
			36	0	2	21.00		20.69		21.05
			36	20	2	21.00		20.74		21.02
			36	39	2	20.94		20.68		20.91
			75	0	2	20.94		20.71		20.96

Band	BW (MHz)	Mode	RB Allocation	RB offset	Target MPR	Avg Pwr (dBm)				
						39700		40620	41540	
						2501 MHz		2593 MHz	2685 MHz	
LTE Band 41	10	QPSK	1	0	0	23.10		22.81		23.50
			1	25	0	23.06		22.76		23.50
			1	49	0	23.20		22.83		23.50
			25	0	1	22.15		21.78		22.37
			25	12	1	22.08		21.86		22.41
			25	25	1	22.05		21.77		22.29
			50	0	1	22.08		21.78		22.30
		16QAM	1	0	1	21.72		22.30		22.1
			1	25	1	21.73		22.15		22.0
			1	49	1	21.76		22.31		22.1
			25	0	2	20.95		20.85		21.29
			25	12	2	20.97		20.80		21.30
			25	25	2	20.97		20.75		21.27
			50	0	2	21.01		20.71		21.28

Band	BW (MHz)	Mode	RB Allocation	RB offset	Target MPR	Avg Pwr (dBm)				
						39675		40620		41565
						2498.5 MHz		2593 MHz		2687.5 MHz
LTE Band 41	5	QPSK	1	0	0	23.06		22.82		23.50
			1	12	0	23.06		22.84		23.50
			1	24	0	23.03		22.76		23.43
			12	0	1	21.95		21.79		22.23
			12	7	1	22.06		21.82		22.28
			12	13	1	22.11		21.79		22.26
			25	0	1	22.01		21.79		22.24
		16QAM	1	0	1	21.93		21.43		22.14
			1	12	1	21.93		21.46		22.08
			1	24	1	21.91		21.37		22.08
			12	0	2	20.79		20.72		21.17
			12	7	2	20.90		20.65		21.2
			12	13	2	20.84		20.62		21.20
			25	0	2	20.91		20.74		21.23

Band	BW (MHz)	Mode	RB Allocation	RB offset	Target MPR	Avg Pwr (dBm)		
						26765	26865	26965
						831.5	836.5	841.5 MHz
LTE Band 26	15	QPSK	1	0	0	23.4	23.5	23.5
			1	37	0	23.3	23.4	23.4
			1	74	0	23.4	23.3	23.3
			36	0	1	22.2	22.2	22.2
			36	20	1	22.2	22.0	22.1
			36	39	1	22.2	22.0	22.0
			75	0	1	22.2	22.0	22.2
		16QAM	1	0	1	22.2	22.2	22.1
			1	37	1	22.1	22.0	22.1
			1	74	1	22.1	22.0	22.0
			36	0	2	21.3	21.4	21.4
			36	20	2	21.3	21.5	21.4
			36	39	2	21.3	21.4	21.3
			75	0	2	21.3	21.4	21.3

Band	BW (MHz)	Mode	RB Allocation	RB offset	Target MPR	Avg Pwr (dBm)		
						26740	26865	26990
						819 MHz	831.5 MHz	844 MHz
LTE Band 26	10	QPSK	1	0	0	23.5	23.5	23.5
			1	25	0	23.4	23.5	23.5
			1	49	0	23.5	23.5	23.5
			25	0	1	22.4	22.3	22.4
			25	12	1	22.4	22.3	22.3
			25	25	1	22.4	22.2	22.3
		50	0	1	22.4	22.2	22.5	
		16QAM	1	0	1	22.4	22.5	22.5
			1	25	1	22.5	22.4	22.5
			1	49	1	22.5	22.3	22.5
			25	0	2	21.4	21.3	21.4
			25	12	2	21.3	21.2	21.3
			25	25	2	21.3	21.1	21.2
			50	0	2	21.3	21.1	21.3

Band	BW (MHz)	Mode	RB Allocation	RB offset	Target MPR	Avg Pwr (dBm)		
						26715	26865	27015
						816.5 MHz	831.5 MHz	846.5 MHz
LTE Band 26	5	QPSK	1	0	0	23.4	23.5	23.5
			1	12	0	23.5	23.5	23.5
			1	24	0	23.5	23.4	23.5
			12	0	1	22.4	22.3	22.4
			12	7	1	22.3	22.2	22.2
			12	13	1	22.2	22.3	22.3
			25	0	1	22.3	22.3	22.3
		16QAM	1	0	1	22.5	22.3	22.4
			1	12	1	22.5	22.2	22.3
			1	24	1	22.5	22.3	22.3
			12	0	2	21.3	21.2	21.2
			12	7	2	21.2	21.2	21.1
			12	13	2	21.2	21.2	21.2
			25	0	2	21.2	21.1	21.1

Band	BW (MHz)	Mode	RB Allocation	RB offset	Target MPR	Avg Pwr (dBm)		
						26705	26865	27025
						815.5 MHz	831.5 MHz	847.5 MHz
LTE Band 26	3	QPSK	1	0	0	23.4	23.3	23.3
			1	8	0	23.4	23.3	23.2
			1	14	0	23.3	23.2	23.2
			8	0	1	22.0	22.0	21.9
			8	4	1	22.1	22.0	21.8
			8	7	1	22.0	21.9	21.9
		16QAM	15	0	1	22.0	22.0	22.0
			1	0	1	22.3	22.5	22.3
			1	8	1	22.2	22.5	22.2
			1	14	1	22.2	22.5	22.3
			8	0	2	21.0	20.7	20.9
			8	4	2	20.9	20.8	20.8
			8	7	2	20.9	20.7	20.8
15	0	2	20.9	20.8	20.9			

Band	BW (MHz)	Mode	RB Allocation	RB offset	Target MPR	Avg Pwr (dBm)		
						26697	26865	27033
						814.7 MHz	831.5 MHz	848.3 MHz
LTE Band 26	1.4	QPSK	1	0	0	23.2	23.2	23.2
			1	3	0	23.2	23.2	23.1
			1	5	0	23.3	23.2	23.1
			3	0	0	23.2	23.1	23.1
			3	1	0	23.2	23.1	23.1
			3	3	0	23.1	23.2	23.0
		6	0	1	22.1	22.0	21.9	
		16QAM	1	0	1	22.3	22.3	22.4
			1	3	1	22.3	22.3	22.3
			1	5	1	22.2	22.3	22.3
			3	0	1	21.9	22.0	22.0
			3	1	1	21.9	22.0	22.0
			3	3	1	21.9	22.0	21.9
			6	0	2	20.9	20.8	20.8

Band	BW (MHz)	Mode	RB Allocation	RB offset	Target MPR	Avg Pwr (dBm)
						23790
						710 MHz
LTE Band 17	10	QPSK	1	0	0	23.4
			1	25	0	23.4
			1	49	0	23.3
			25	0	1	22.2
			25	12	1	22.3
			25	25	1	22.1
			50	0	1	22.2
		16QAM	1	0	1	22.4
			1	25	1	22.4
			1	49	1	22.4
			25	0	2	21.2
			25	12	2	21.1
			25	25	2	21.1
			50	0	2	21.1

Band	BW (MHz)	Mode	RB Allocation	RB offset	Target MPR	Avg Pwr (dBm)
						23790
						710 MHz
LTE Band 17	5	QPSK	1	0	0	23.3
			1	12	0	23.2
			1	24	0	23.2
			12	0	1	22.3
			12	7	1	22.1
			12	13	1	22.1
			25	0	1	22.2
		16QAM	1	0	1	22.1
			1	12	1	22.1
			1	24	1	22.1
			12	0	2	21.1
			12	7	2	21.0
			12	13	2	21.1
			25	0	2	21.1

Band	BW (MHz)	Mode	RB Allocation	RB offset	Target MPR	Avg Pwr (dBm)
						23230
						782 MHz
LTE Band 13	10	QPSK	1	0	0	23.20
			1	25	0	23.30
			1	49	0	23.20
			25	0	1	22.00
			25	12	1	21.90
			25	25	1	22.00
			50	0	1	21.90
		16QAM	1	0	1	22.00
			1	25	1	22.10
			1	49	1	22.10
			25	0	2	20.90
			25	12	2	21.00
			25	25	2	21.00
			50	0	2	20.90
Band	BW (MHz)	Mode	RB Allocation	RB offset	Target MPR	Avg Pwr (dBm)
						23230
						782 MHz
LTE Band 13	5	QPSK	1	0	0	23.10
			1	12	0	23.10
			1	24	0	23.30
			12	0	1	21.90
			12	7	1	22.00
			12	13	1	22.00
			25	0	1	21.90
		16QAM	1	0	1	21.90
			1	12	1	21.90
			1	24	1	22.00
			12	0	2	20.80
			12	7	2	20.80
			12	13	2	20.80
			25	0	2	20.80

Band	BW (MHz)	Mode	RB Allocation	RB offset	Target MPR	Avg Pwr (dBm)		
						20450	20525	20600
						829 MHz	836.5 MHz	844 MHz
LTE Band 5	10	QPSK	1	0	0	23.3	23.5	23.3
			1	25	0	23.3	23.5	23.3
			1	49	0	23.3	23.4	23.3
			25	0	1	22.1	22.2	22.2
			25	12	1	22.1	22.2	22.2
			25	25	1	22.0	22.0	22.0
		16QAM	50	0	1	22.0	22.1	22.2
			1	0	1	22.5	22.3	22.5
			1	25	1	22.6	22.3	22.3
			1	49	1	22.5	22.3	22.2
			25	0	2	21.1	21.1	21.1
			25	12	2	21.1	21.1	21.1
			25	25	2	20.9	21.0	21.0
			50	0	2	21.1	21.1	21.1

Band	BW (MHz)	Mode	RB Allocation	RB offset	Target MPR	Avg Pwr (dBm)		
						20425	20525	20625
						826.5 MHz	836.5 MHz	846.5 MHz
LTE Band 5	5	QPSK	1	0	0	23.4	23.4	23.5
			1	12	0	23.4	23.3	23.5
			1	24	0	23.4	23.2	23.4
			12	0	1	22.2	22.2	22.2
			12	7	1	22.2	22.2	22.1
			12	13	1	22.2	22.1	22.1
			25	0	1	22.2	22.2	22.1
		16QAM	1	0	1	22.4	22.3	22.2
			1	12	1	22.4	22.2	22.1
			1	24	1	22.4	22.2	22.2
			12	0	2	21.1	21.1	21.1
			12	7	2	21.1	21.1	21.1
			12	13	2	21.1	21.0	21.0
			25	0	2	21.1	21.1	21.0

Band	BW (MHz)	Mode	RB Allocation	RB offset	Target MPR	Avg Pwr (dBm)		
						20415	20525	20635
						825.5 MHz	836.5 MHz	847.5 MHz
LTE Band 5	3	QPSK	1	0	0	23.5	23.4	23.4
			1	8	0	23.5	23.4	23.4
			1	14	0	23.5	23.4	23.4
			8	0	1	22.1	22.2	22.2
			8	4	1	22.2	22.2	22.1
			8	7	1	22.2	22.2	22.1
			15	0	1	22.2	22.2	22.1
		16QAM	1	0	1	22.6	22.5	22.3
			1	8	1	22.5	22.5	22.4
			1	14	1	22.6	22.2	22.1
			8	0	2	21.0	21.1	20.1
			8	4	2	21.1	21.1	20.8
			8	7	2	21.1	21.1	20.8
			15	0	2	21.1	21.1	20.9

Band	BW (MHz)	Mode	RB Allocation	RB offset	Target MPR	Avg Pwr (dBm)		
						20407	20525	20643
						824.7 MHz	836.5 MHz	848.3 MHz
LTE Band 5	1.4	QPSK	1	0	0	23.4	23.4	23.4
			1	3	0	23.5	23.5	23.3
			1	5	0	23.5	23.5	23.3
			3	0	0	23.3	23.4	23.3
			3	1	0	23.3	23.3	23.3
			3	3	0	23.3	23.3	23.2
			6	0	1	22.2	22.1	22.1
		16QAM	1	0	1	22.5	22.4	22.5
			1	3	1	22.4	22.4	22.4
			1	5	1	22.5	22.3	22.4
			3	0	1	22.2	22.2	22.1
			3	1	1	22.2	22.2	22.0
			3	3	1	22.2	22.2	21.9
			6	0	2	21.1	21.0	20.9

9. PEAK TO AVERAGE RATIO

Test Procedure

Per KDB 971168 D01 Power Meas License Digital Systems v02r02

Test Spec

In addition, when the transmitter power is measured in terms of average value, the peak-to-average ratio of the power shall not exceed 13 dB.

9.1. CONDUCTED PEAK TO AVERAGE RESULT

GSM

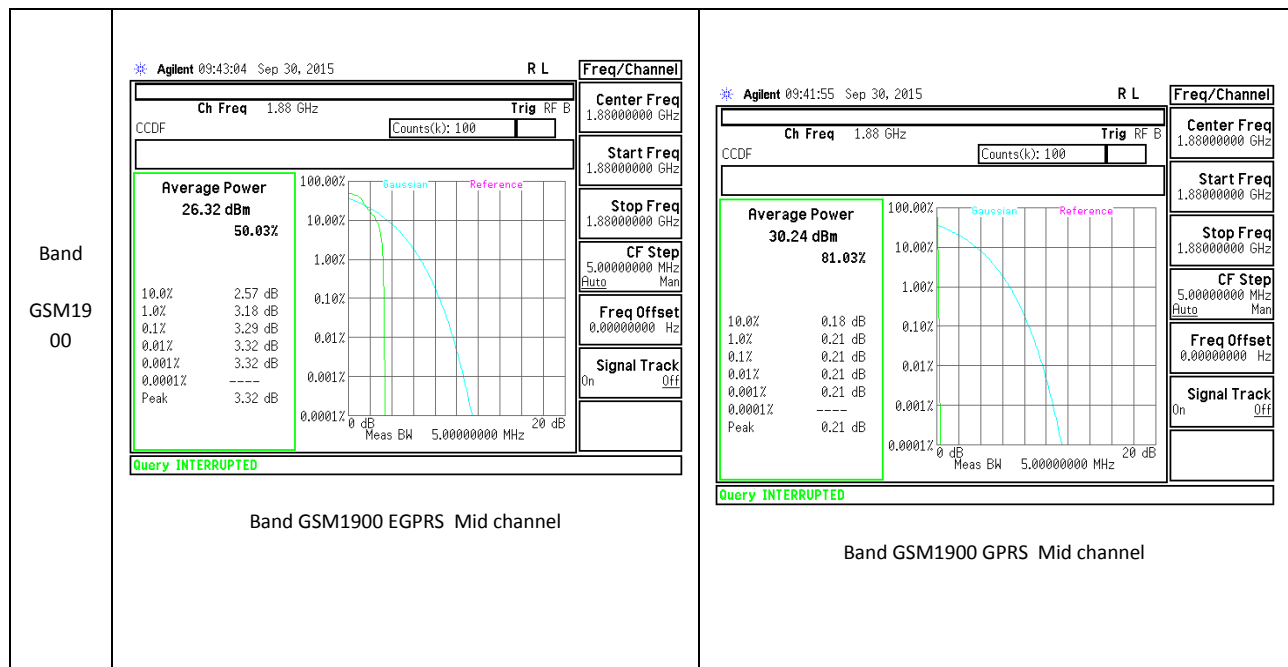

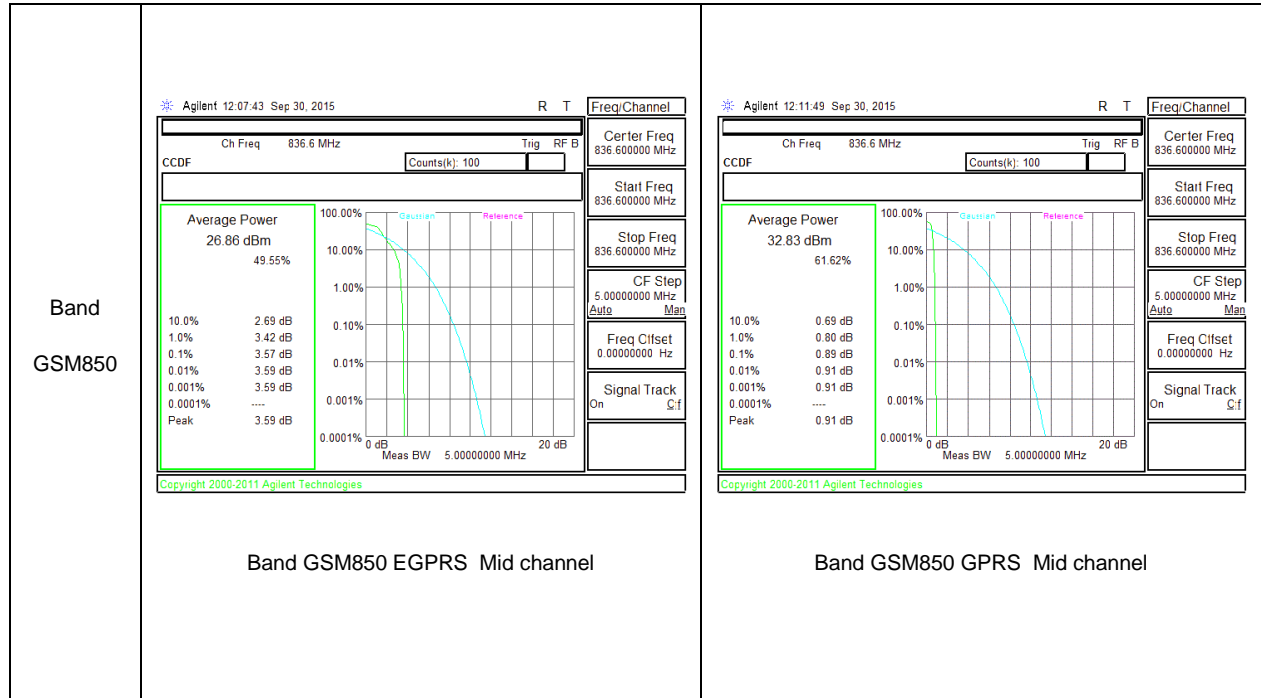

WCDMA

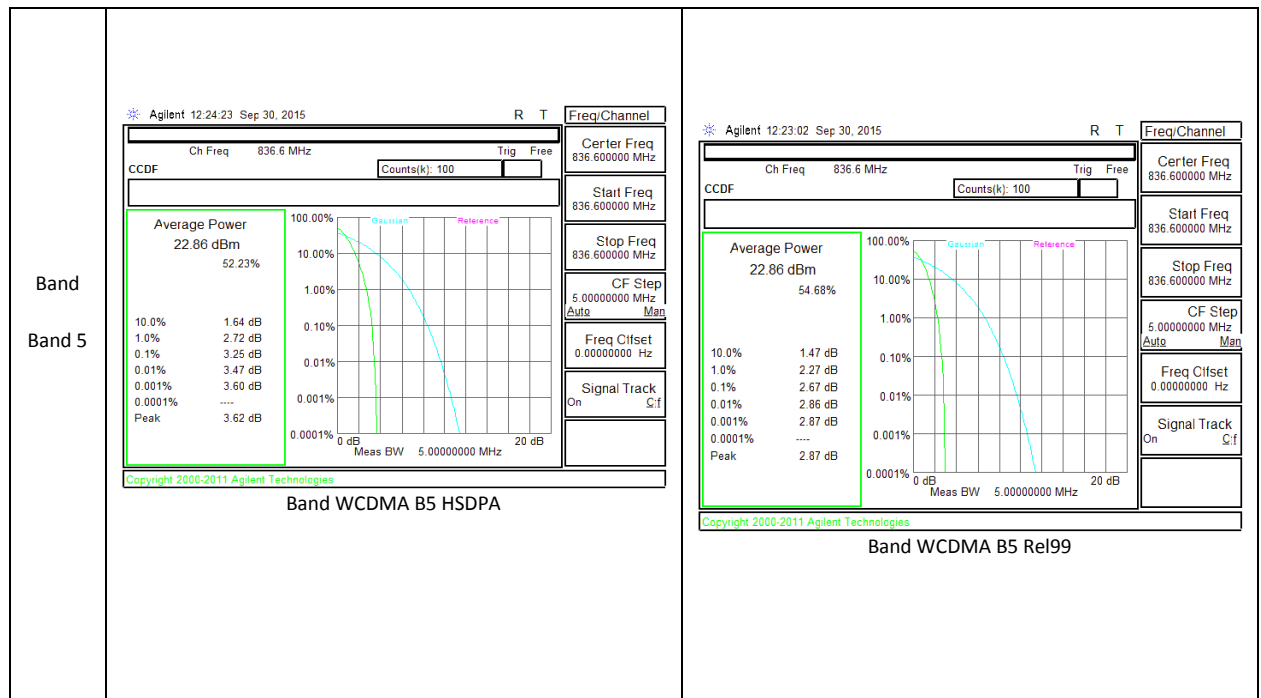

LTE5

<p>Band LTE5 10MHz</p>	<p>Agilent 10:31:44 Oct 1, 2015 R T Amplitude</p> <p>Ch Freq 836.5 MHz Trig Free</p> <p>CCDF Counts(k): 100</p> <p>Average Power 21.71 dBm 44.44%</p> <p>10.0% 2.61 dB 1.0% 4.92 dB 0.1% 5.76 dB 0.01% 6.06 dB 0.001% 6.12 dB Peak 6.12 dB</p> <p>Ref Level 28.34 dBm Attenuation 30.00 dB Scale/Div 10.00 dB Scale Type Log Presel Center Presel Adj just [3-26 GHz] 0.000 Hz More 1 of 3</p> <p>Copyright 2000-2011 Agilent Technologies</p> <p>Band LTE5 10MHz 16QAM Mid channel</p>	<p>Agilent 10:31:31 Oct 1, 2015 R T Amplitude</p> <p>Ch Freq 836.5 MHz Trig Free</p> <p>CCDF Counts(k): 100</p> <p>Average Power 23.02 dBm 50.27%</p> <p>10.0% 2.38 dB 1.0% 3.61 dB 0.1% 4.24 dB 0.01% 4.39 dB 0.001% 4.44 dB Peak 4.44 dB</p> <p>Ref Level 28.51 dBm Attenuation 30.00 dB Scale/Div 10.00 dB Scale Type Log Presel Center Presel Adj just [3-26 GHz] 0.000 Hz More 1 of 3</p> <p>Copyright 2000-2011 Agilent Technologies</p> <p>Band LTE5 10MHz QPSK Mid channel</p>
<p>Band LTE5 5MHz</p>	<p>Agilent 10:31:13 Oct 1, 2015 R T Amplitude</p> <p>Ch Freq 836.5 MHz Trig Free</p> <p>CCDF Counts(k): 100</p> <p>Average Power 22.06 dBm 45.56%</p> <p>10.0% 2.63 dB 1.0% 4.47 dB 0.1% 5.23 dB 0.01% 5.75 dB 0.001% 5.78 dB Peak 5.78 dB</p> <p>Ref Level 28.36 dBm Attenuation 30.00 dB Scale/Div 10.00 dB Scale Type Log Presel Center Presel Adj just [3-26 GHz] 0.000 Hz More 1 of 3</p> <p>Copyright 2000-2011 Agilent Technologies</p> <p>Band LTE5 5MHz 16QAM Mid channel</p>	<p>Agilent 10:54:37 Oct 1, 2015 R T Amplitude</p> <p>Ch Freq 836.5 MHz Trig Free</p> <p>CCDF Counts(k): 100</p> <p>Average Power 23.03 dBm 49.92%</p> <p>10.0% 2.45 dB 1.0% 3.83 dB 0.1% 4.53 dB 0.01% 4.74 dB 0.001% 4.74 dB Peak 4.74 dB</p> <p>Ref Level 28.33 dBm Attenuation 30.00 dB Scale/Div 10.00 dB Scale Type Log Presel Center Presel Adj just [3-26 GHz] 0.000 Hz More 1 of 3</p> <p>Copyright 2000-2011 Agilent Technologies</p> <p>Band LTE5 5MHz QPSK Mid channel</p>

<p>Band LTE5 3MHz</p>	<p>Agilent 11:08:28 Oct 1, 2015 R T Amplitude</p> <p>Ch Freq 836.5 MHz Trig Free</p> <p>CCDF Counts(k): 100</p> <p>Average Power 21.81 dBm 44.81%</p> <p>10.0% 2.76 dB 1.0% 4.83 dB 0.1% 5.56 dB 0.01% 5.77 dB 0.001% 5.80 dB Peak 5.80 dB</p> <p>Copyright 2000-2011 Agilent Technologies</p> <p>Ref Level 28.19 dBm Attenuation 30.00 dB Scale/Div 10.00 dB Scale Type Lin Presel Center Presel Adj Just [3-26 GHz] 0.000 Hz More 1 of 3</p> <p>Band LTE5 3MHz 16QAM Mid channel</p>	<p>Agilent 11:08:15 Oct 1, 2015 R T Amplitude</p> <p>Ch Freq 836.5 MHz Trig Free</p> <p>CCDF Counts(k): 100</p> <p>Average Power 23.10 dBm 50.40%</p> <p>10.0% 2.43 dB 1.0% 3.75 dB 0.1% 4.35 dB 0.01% 4.48 dB 0.001% 4.50 dB Peak 4.50 dB</p> <p>Copyright 2000-2011 Agilent Technologies</p> <p>Ref Level 28.33 dBm Attenuation 30.00 dB Scale/Div 10.00 dB Scale Type Lin Presel Center Presel Adj Just [3-26 GHz] 0.000 Hz More 1 of 3</p> <p>Band LTE5 3MHz QPSK Mid channel</p>
<p>Band LTE5 1.4MHz</p>	<p>Agilent 11:07:57 Oct 1, 2015 R T Amplitude</p> <p>Ch Freq 836.5 MHz Trig Free</p> <p>CCDF Counts(k): 100</p> <p>Average Power 22.21 dBm 45.44%</p> <p>10.0% 2.67 dB 1.0% 4.68 dB 0.1% 5.26 dB 0.01% 5.46 dB 0.001% 5.49 dB Peak 5.49 dB</p> <p>Copyright 2000-2011 Agilent Technologies</p> <p>Ref Level 28.43 dBm Attenuation 30.00 dB Scale/Div 10.00 dB Scale Type Lin Presel Center Presel Adj Just [3-26 GHz] 0.000 Hz More 1 of 3</p> <p>Band LTE5 1.4MHz 16QAM Mid channel</p>	<p>Agilent 11:07:44 Oct 1, 2015 R T Amplitude</p> <p>Ch Freq 836.5 MHz Trig Free</p> <p>CCDF Counts(k): 100</p> <p>Average Power 23.11 dBm 50.11%</p> <p>10.0% 2.37 dB 1.0% 3.58 dB 0.1% 4.19 dB 0.01% 4.48 dB 0.001% 4.53 dB Peak 4.53 dB</p> <p>Copyright 2000-2011 Agilent Technologies</p> <p>Ref Level 27.93 dBm Attenuation 30.00 dB Scale/Div 10.00 dB Scale Type Lin Presel Center Presel Adj Just [3-26 GHz] 0.000 Hz More 1 of 3</p> <p>Band LTE5 1.4MHz QPSK Mid channel</p>

LTE13

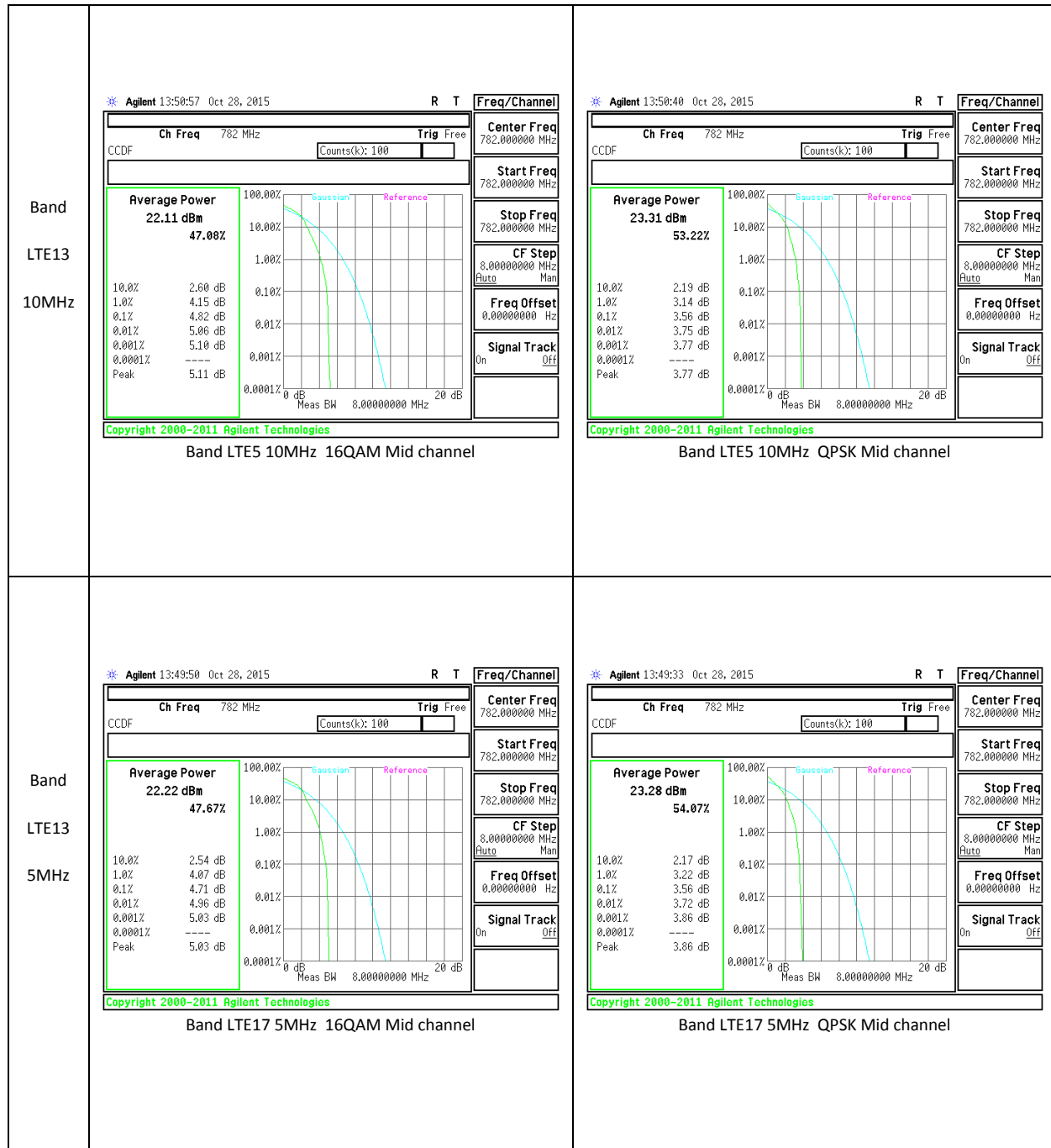

LTE17

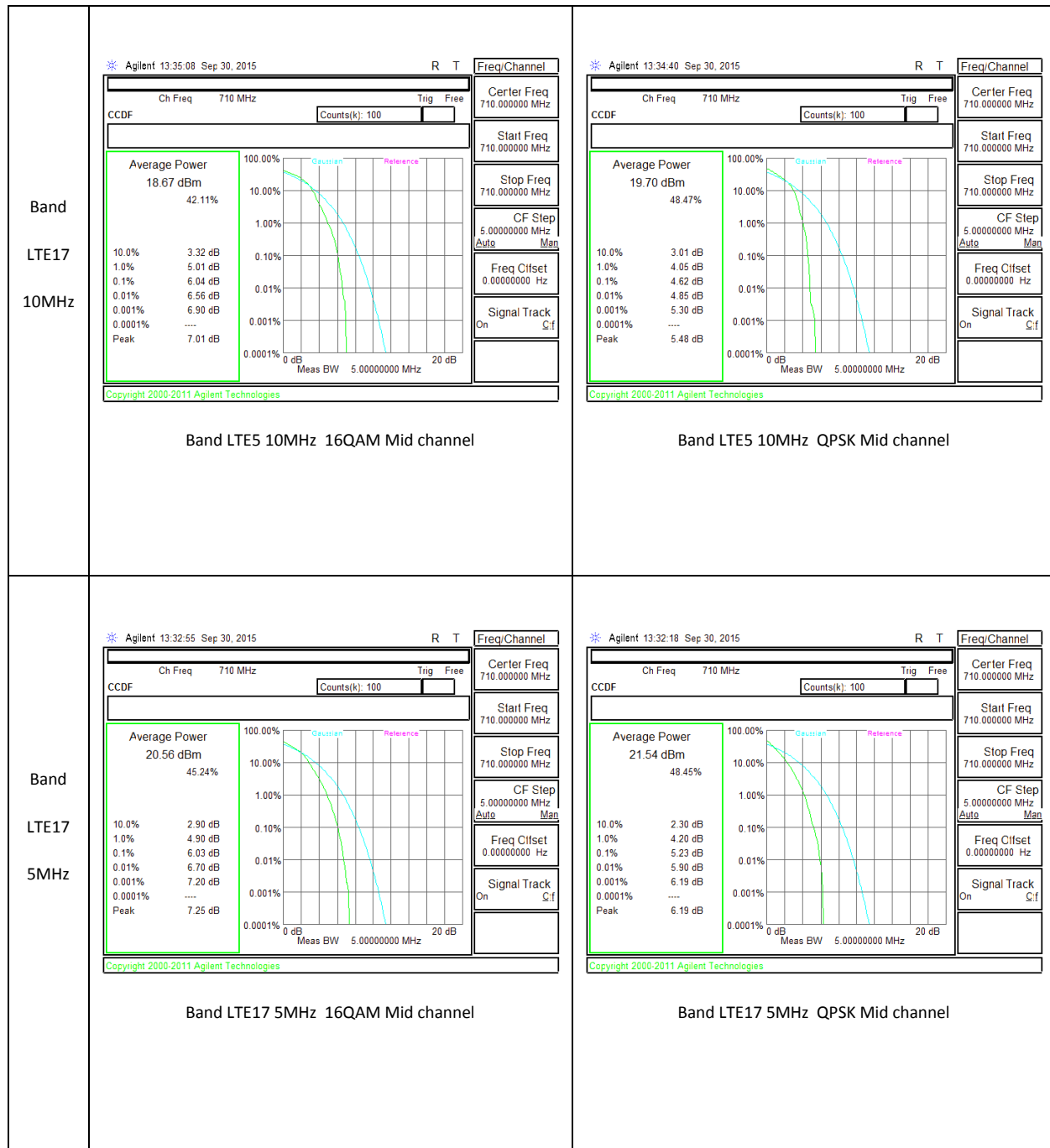

LTE26

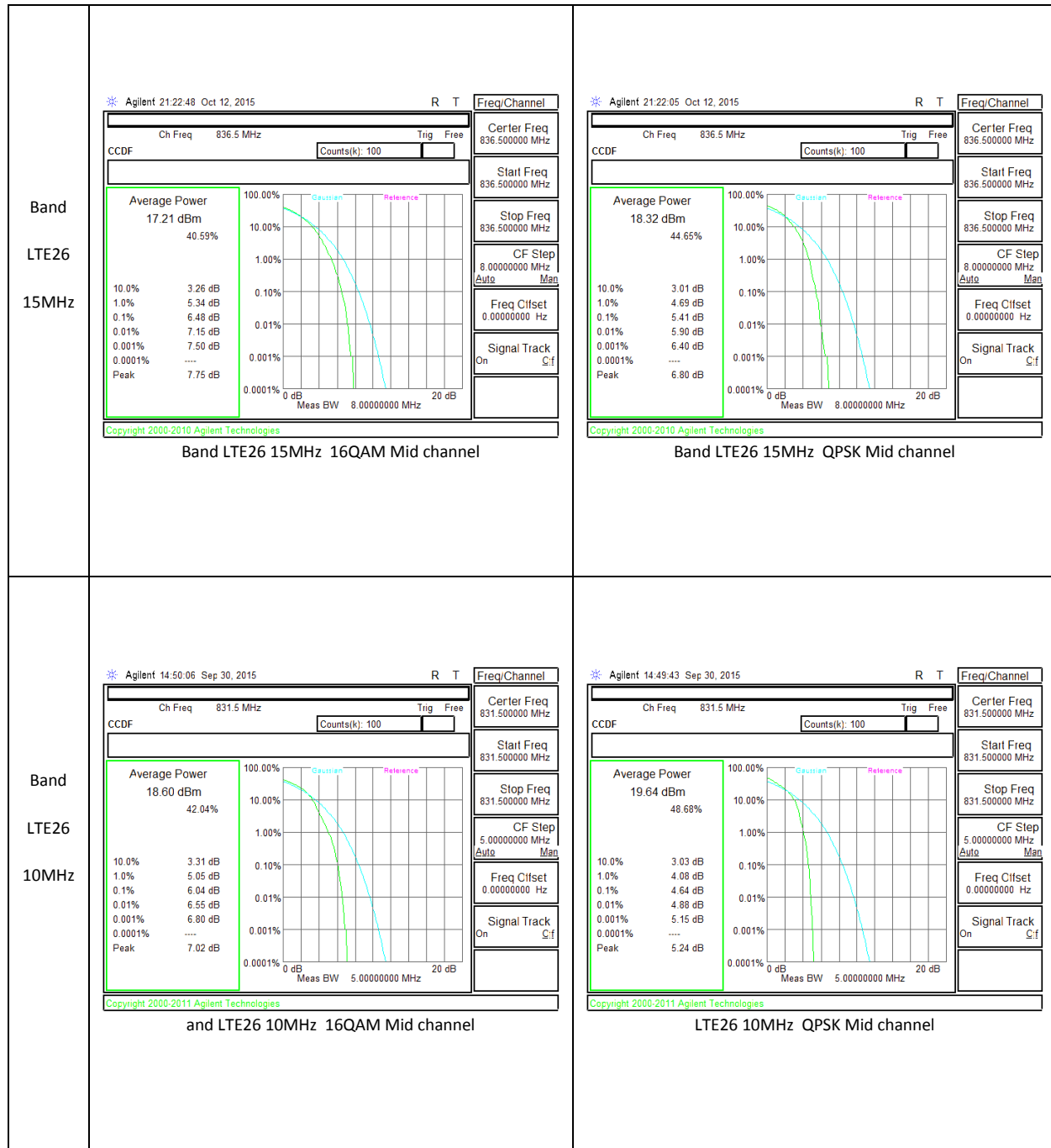

<p>Band LTE26 5MHz</p>	<p>Agilent 14:44:20 Sep 30, 2015 R T Freq/Channel</p> <p>Ch Freq 831.5 MHz Trig Free</p> <p>Center Freq 831.500000 MHz</p> <p>Start Freq 831.500000 MHz</p> <p>Stop Freq 831.500000 MHz</p> <p>CF Step 5.00000000 MHz Auto Man</p> <p>Freq Cifset 0.00000000 Hz</p> <p>Signal Track On Cf</p> <p>Average Power 20.56 dBm 46.38%</p> <p>10.0% 2.80 dB 1.0% 4.76 dB 0.1% 5.94 dB 0.01% 6.70 dB 0.001% 7.25 dB 0.0001% ---- Peak 7.33 dB</p> <p>Copyright 2000-2011 Agilent Technologies</p> <p>Band LTE26 5MHz 16QAM Mid channel</p>	<p>Agilent 14:42:04 Sep 30, 2015 R T Freq/Channel</p> <p>Ch Freq 831.5 MHz Trig Free</p> <p>Center Freq 831.500000 MHz</p> <p>Start Freq 831.500000 MHz</p> <p>Stop Freq 831.500000 MHz</p> <p>CF Step 5.00000000 MHz Auto Man</p> <p>Freq Cifset 0.00000000 Hz</p> <p>Signal Track On Cf</p> <p>Average Power 21.52 dBm 48.82%</p> <p>10.0% 2.27 dB 1.0% 4.19 dB 0.1% 5.22 dB 0.01% 5.80 dB 0.001% 6.30 dB 0.0001% ---- Peak 6.57 dB</p> <p>Copyright 2000-2011 Agilent Technologies</p> <p>Band LTE26 5MHz QPSK Mid channel</p>
<p>Band LTE26 3MHz</p>	<p>Agilent 14:22:18 Oct 28, 2015 R T Freq/Channel</p> <p>Ch Freq 831.5 MHz Trig Free</p> <p>Center Freq 831.500000 MHz</p> <p>Start Freq 831.500000 MHz</p> <p>Stop Freq 831.500000 MHz</p> <p>CF Step 8.00000000 MHz Auto Man</p> <p>Freq Offset 0.00000000 Hz</p> <p>Signal Track On Off</p> <p>Average Power 22.22 dBm 44.11%</p> <p>10.0% 2.68 dB 1.0% 4.79 dB 0.1% 5.90 dB 0.01% 6.18 dB 0.001% 6.24 dB 0.0001% ---- Peak 6.24 dB</p> <p>Copyright 2000-2011 Agilent Technologies</p> <p>Band LTE26 3MHz 16QAM Mid channel</p>	<p>Agilent 14:21:58 Oct 28, 2015 R T Freq/Channel</p> <p>Ch Freq 831.5 MHz Trig Free</p> <p>Center Freq 831.500000 MHz</p> <p>Start Freq 831.500000 MHz</p> <p>Stop Freq 831.500000 MHz</p> <p>CF Step 8.00000000 MHz Auto Man</p> <p>Freq Offset 0.00000000 Hz</p> <p>Signal Track On Off</p> <p>Average Power 23.39 dBm 49.13%</p> <p>10.0% 2.43 dB 1.0% 3.78 dB 0.1% 4.38 dB 0.01% 4.56 dB 0.001% 4.56 dB 0.0001% ---- Peak 4.56 dB</p> <p>Copyright 2000-2011 Agilent Technologies</p> <p>Band LTE26 3MHz QPSK Mid channel</p>

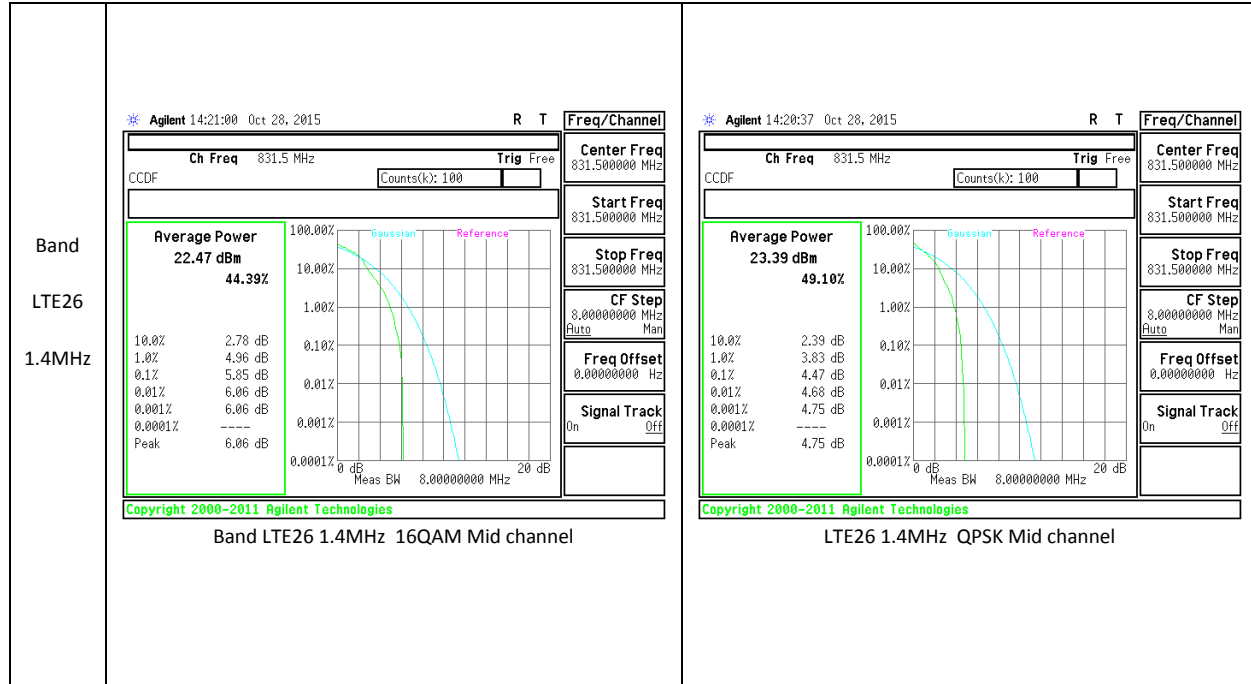

LTE41

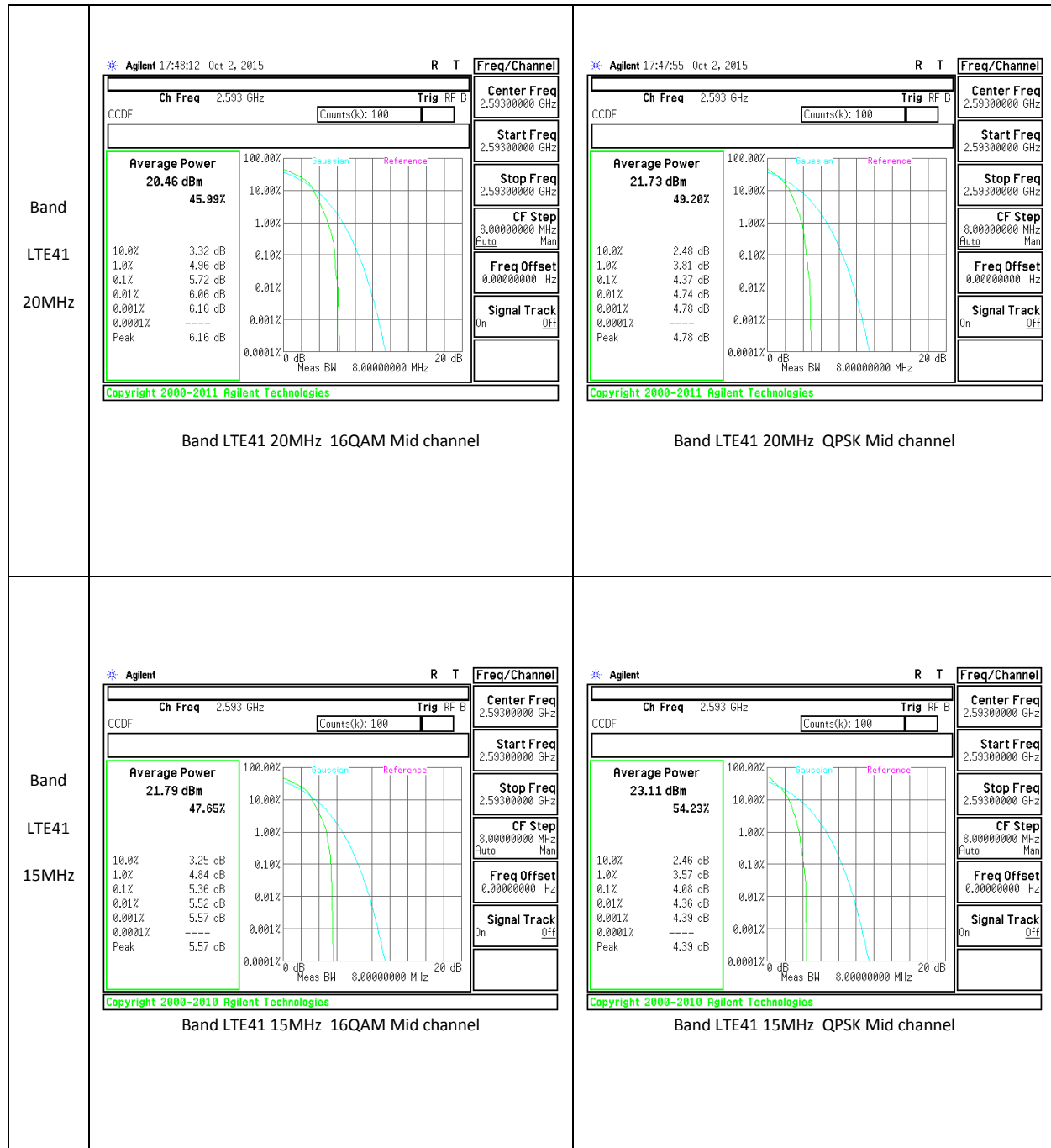

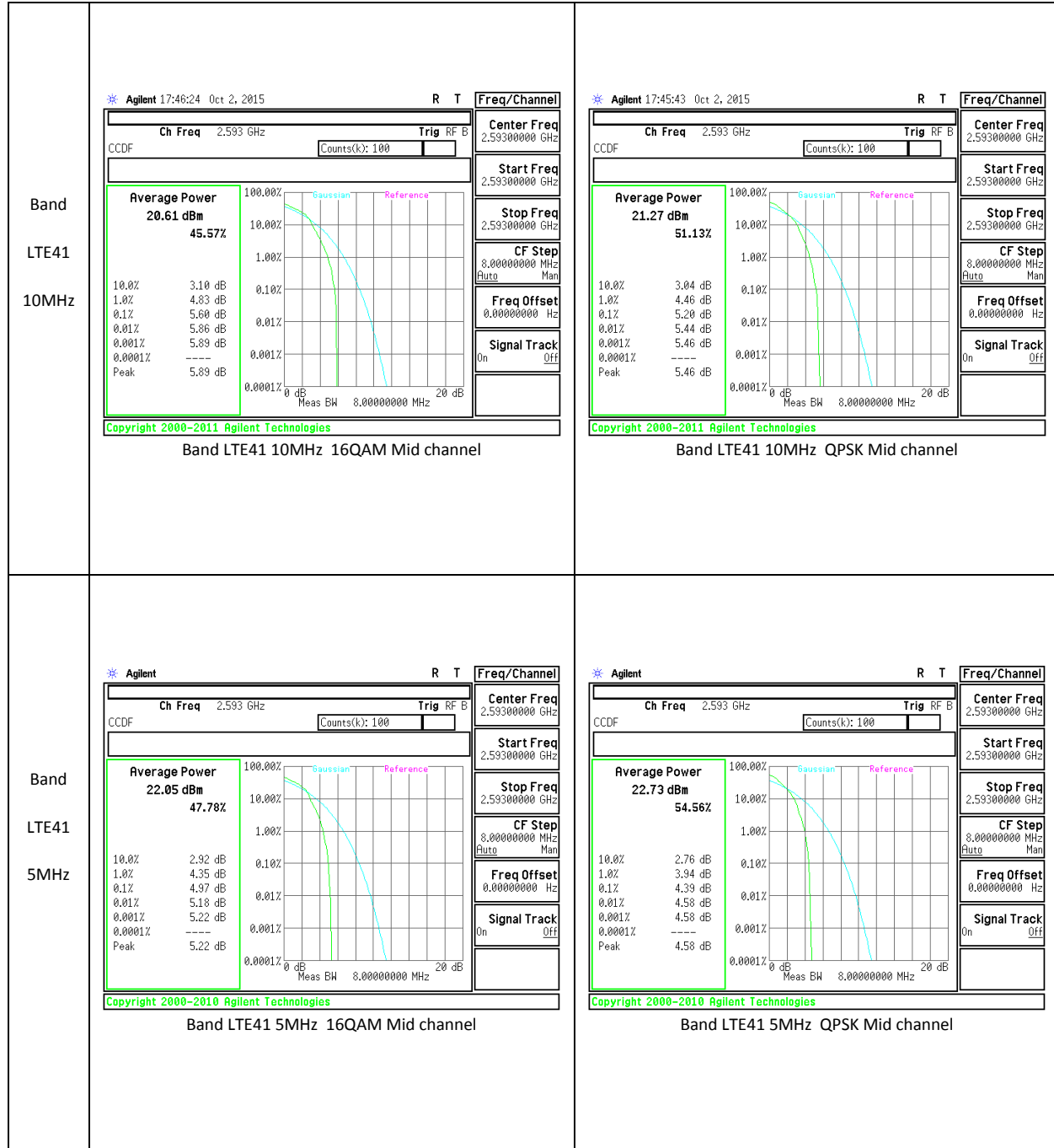

LTE Band 41

Sub frame setting:

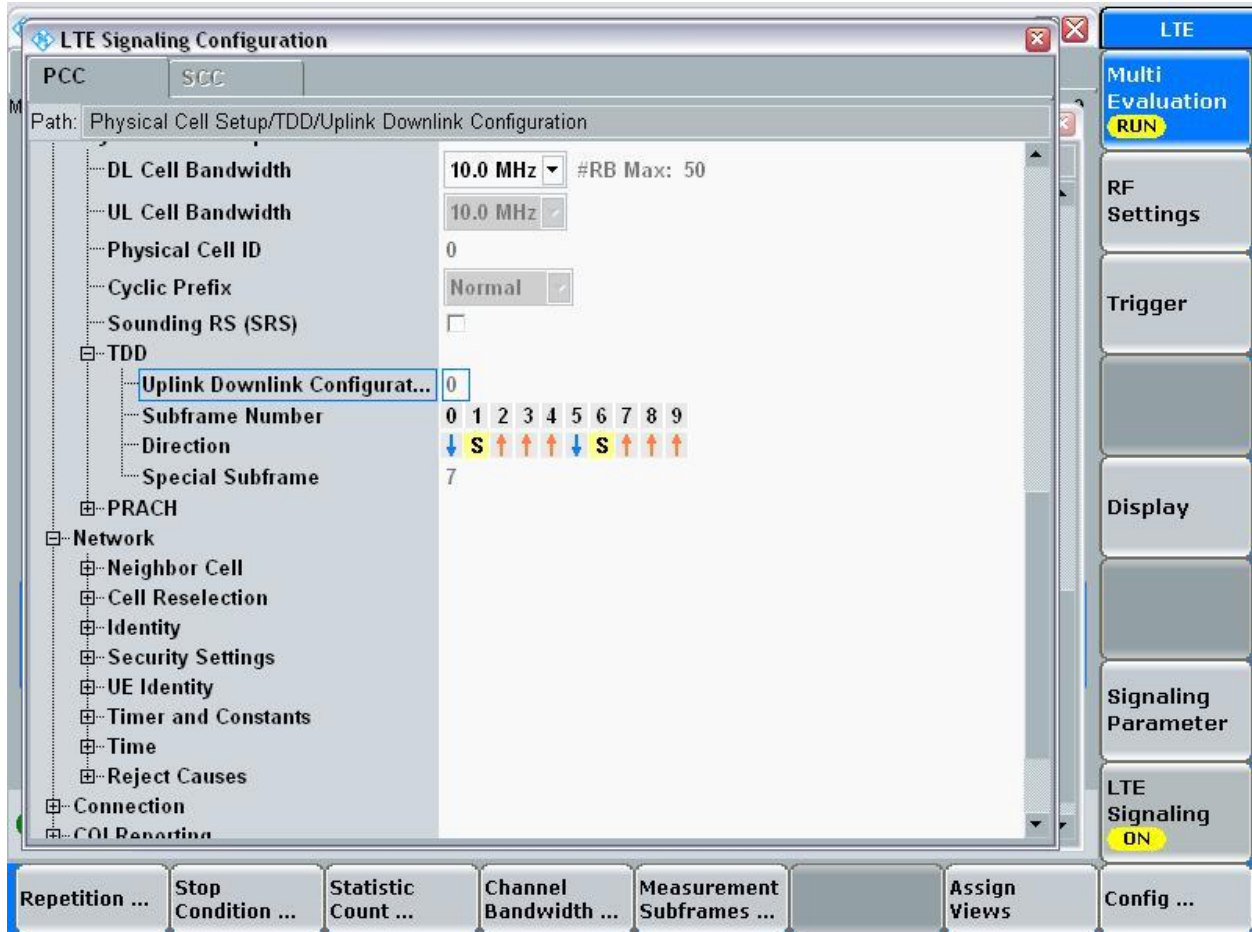

So average reading need apply 4.44dB duty cycle factor ($20\log(6/10)$).

10. LIMITS AND CONDUCTED RESULTS

10.1. OCCUPIED BANDWIDTH

RULE PART(S)

FCC: §2.1049

IC: RSS-132, 4.5; RSS-133, 6.5

LIMITS

For reporting purposes only

TEST PROCEDURE

The transmitter output was connected to a calibrated coaxial cable and coupler, the other end of which was connected to a spectrum analyzer. The occupied bandwidth was measured with the spectrum analyzer at the low, middle and high channel in each band. The -26dB bandwidth was also measured and recorded.

(KDB 971168 D01 Power Meas License Digital Systems v02r02)

MODES TESTED

GSM, WCDMA and LTE

10.1.1. OCCUPIED BANDWIDTH RESULTS

Band	Mode	Channel	f (MHz)	99% BW(kHz)	-26dB BW (kHz)
GSM850	GPRS	128	824.2	243.9578	319.419
		190	836.6	242.8803	307.602
		251	848.8	246.3422	315.660
	EGPRS	128	824.2	242.6633	303.676
		190	836.6	245.7639	300.866
		251	848.8	238.0673	310.080
GSM1900	GPRS	512	1850.2	242.0623	300.768
		661	1880	238.9028	309.508
		810	1909.8	245.0130	305.997
	EGPRS	512	1850.2	239.8681	306.188
		661	1880	244.0672	323.657
		810	1909.8	244.3291	308.814
Band 5	Rel99	4132	826.4	4.1957	4.757
		4183	836.6	4.1421	4.754
		4233	846.6	4.1370	4.749
	HSDPA	4132	826.4	4.1483	4.726
		4183	836.6	4.1298	4.703
		4233	846.6	4.1461	4.723

10.1.2. LTE OCCUPIED BANDWIDTH RESULTS

Band	BW(MHz)	Mode	RB/RB Size	f (MHz)	99% BW (MHz)	-26dB BW (MHz)
LTE41	20	16QAM	100/0	2506	17.8786	19.352
			100/0	2593	17.8323	19.646
			100/0	2680	17.8360	19.797
		QPSK	100/0	2506	17.8873	19.539
			100/0	2593	17.8649	20.021
			100/0	2680	17.8190	19.535
	15	16QAM	75/0	2503.5	13.4466	15.304
			75/0	2593	13.3971	15.246
			75/0	2682.5	13.4092	15.038
		QPSK	75/0	2503.5	13.3873	14.866
			75/0	2593	13.4041	15.195
			75/0	2682.5	13.4445	15.275
	10	16QAM	50/0	2501	8.9422	10.125
			50/0	2593	8.9634	9.859
			50/0	2685	8.9487	10.211
		QPSK	50/0	2501	8.9373	9.869
			50/0	2593	8.9492	10.390
			50/0	2685	8.9641	10.044
	5	16QAM	25/0	2498.5	4.5065	5.246
			25/0	2593	4.5007	5.117
			25/0	2687.5	4.5054	5.440
		QPSK	25/0	2498.5	4.5068	5.273
			25/0	2593	4.5066	5.207
			25/0	2687.5	4.5040	5.398

Band	BW(MHz)	Mode	RB/RB Size	f (MHz)	99% BW (MHz)	-26dB BW (MHz)
LTE26	1.4	QPSK	6/0	814.7	1.0925	1.386
			6/0	831.5	1.0912	1.369
			6/0	848.3	1.0852	1.302
		16QAM	6/0	814.7	1.0932	1.373
			6/0	831.5	1.0944	1.387
			6/0	848.3	1.0915	1.358
	3	QPSK	15/0	815.5	2.6892	3.069
			15/0	831.5	2.689	3.070
			15/0	847.5	2.6926	3.037
		16QAM	15/0	815.5	2.6921	3.112
			15/0	831.5	2.6989	3.103
			15/0	847.5	2.6897	3.040
	5	QPSK	25/0	816.5	4.5285	5.5358
			25/0	831.5	4.5163	5.137
			25/0	846.5	4.5148	5.287
		16QAM	25/0	816.5	4.5213	5.266
			25/0	831.5	4.4994	5.175
			25/0	846.5	4.5223	5.219
	10	QPSK	50/0	819	8.9617	10.554
			50/0	831.5	8.9572	9.974
			50/0	844	8.9621	10.272
		16QAM	50/0	819	8.9557	10.051
			50/0	831.5	8.9713	9.939
			50/0	844	8.9893	10.256
15	QPSK	75/0	831.5	13.4104	15.013	
		75/0	836.5	13.4542	15.183	
		75/0	841.5	13.4163	14.871	
	16QAM	75/0	831.5	13.3757	14.860	
		75/0	836.5	13.4480	15.273	
		75/0	841.5	13.4715	15.047	

Band	BW(MHz)	Mode	RB/RB Size	f (MHz)	99% BW (MHz)	-26dB BW (MHz)
LTE13	5	QPSK	25/0	779.5	4.5206	5.373
			25/0	782	4.5029	5.172
			25/0	784.5	4.5040	5.193
		16QAM	25/0	779.5	4.5254	5.303
			25/0	782	4.4922	5.342
			25/0	784.5	4.5096	5.195
	10	QPSK	50/0	782	8.9899	10.121
		16QAM	50/0	782	8.9625	10.297

Band	BW(MHz)	Mode	RB/RB Size	f (MHz)	99% BW (MHz)	-26dB BW (MHz)
LTE17	5	QPSK	25/0	706.5	4.4980	5.182
			25/0	710	4.5027	5.322
			25/0	713.5	4.5118	5.322
		16QAM	25/0	706.5	4.5081	5.187
			25/0	710	4.5123	5.215
			25/0	713.5	4.5094	5.212
	10	QPSK	50/0	709	8.9467	9.960
			50/0	710	8.9474	10.000
			50/0	711	8.9404	10.059
		16QAM	50/0	709	8.9317	9.989
			50/0	710	8.9304	10.076
			50/0	711	8.9554	10.258

Band	BW(MHz)	Mode	RB/RB Size	f (MHz)	99% BW (MHz)	-26dB BW (MHz)
LTE5	1.4	QPSK	6/0	824.7	1.0902	1.361
			6/0	836.5	1.0840	1.357
			6/0	848.3	1.0875	1.356
		16QAM	6/0	824.7	1.0891	1.388
			6/0	836.5	1.0918	1.374
			6/0	848.3	1.0868	1.330
	3	QPSK	15/0	825.5	2.6850	3.105
			15/0	836.5	2.6905	3.042
			15/0	847.5	2.6996	3.050
		16QAM	15/0	825.5	2.6981	3.003
			15/0	836.5	2.6962	3.044
			15/0	847.5	2.6858	3.065
	5	QPSK	25/0	826.5	4.5029	5.197
			25/0	836.5	4.5009	5.254
			25/0	846.5	4.5136	5.327

		16QAM	25/0	826.5	4.5027	5.347
			25/0	836.5	4.5130	5.177
			25/0	846.5	4.5033	5.231
	10	QPSK	50/0	829	8.9522	10.015
			50/0	836.5	8.9314	10.094
			50/0	844	8.9471	9.935
		16QAM	50/0	829	8.9287	9.892
			50/0	836.5	8.9486	10.122
			50/0	844	8.9346	10.382

10.1.1. OCCUPIED BANDWIDTH PLOTS

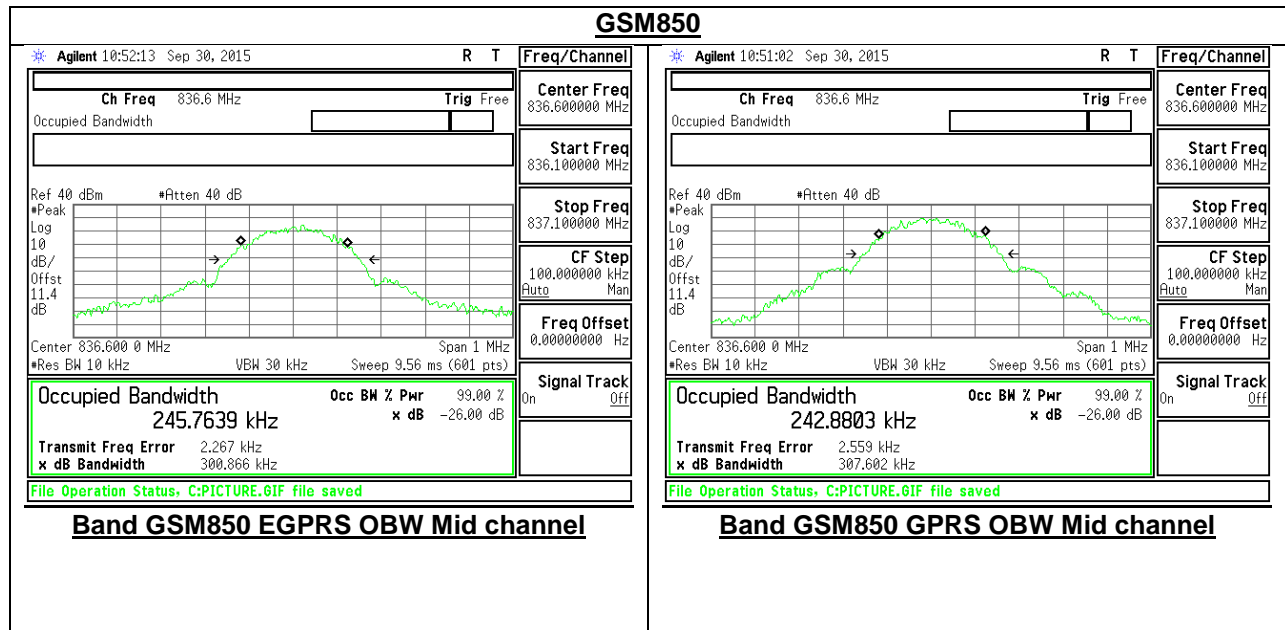
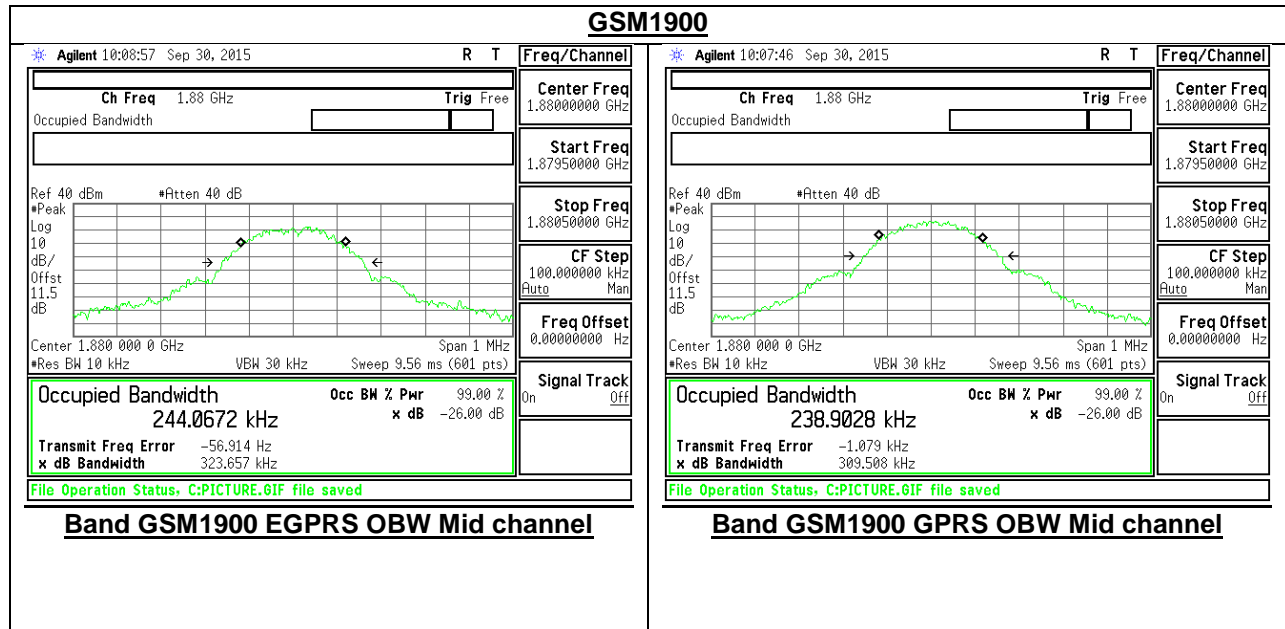

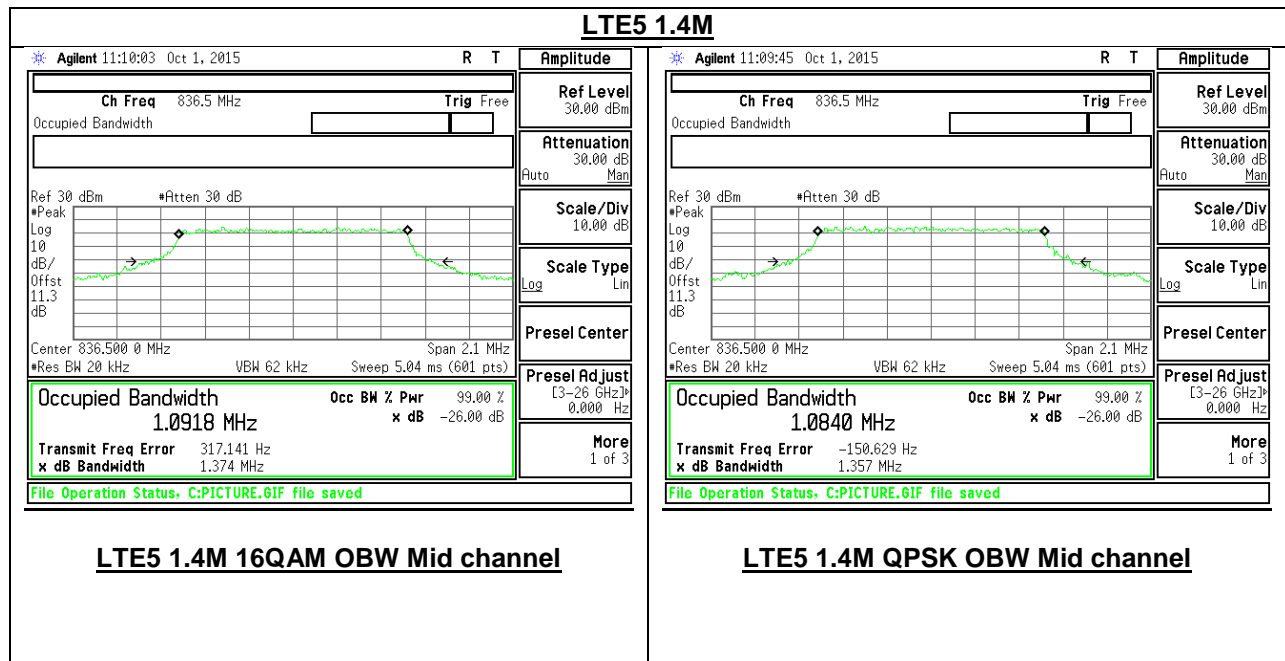
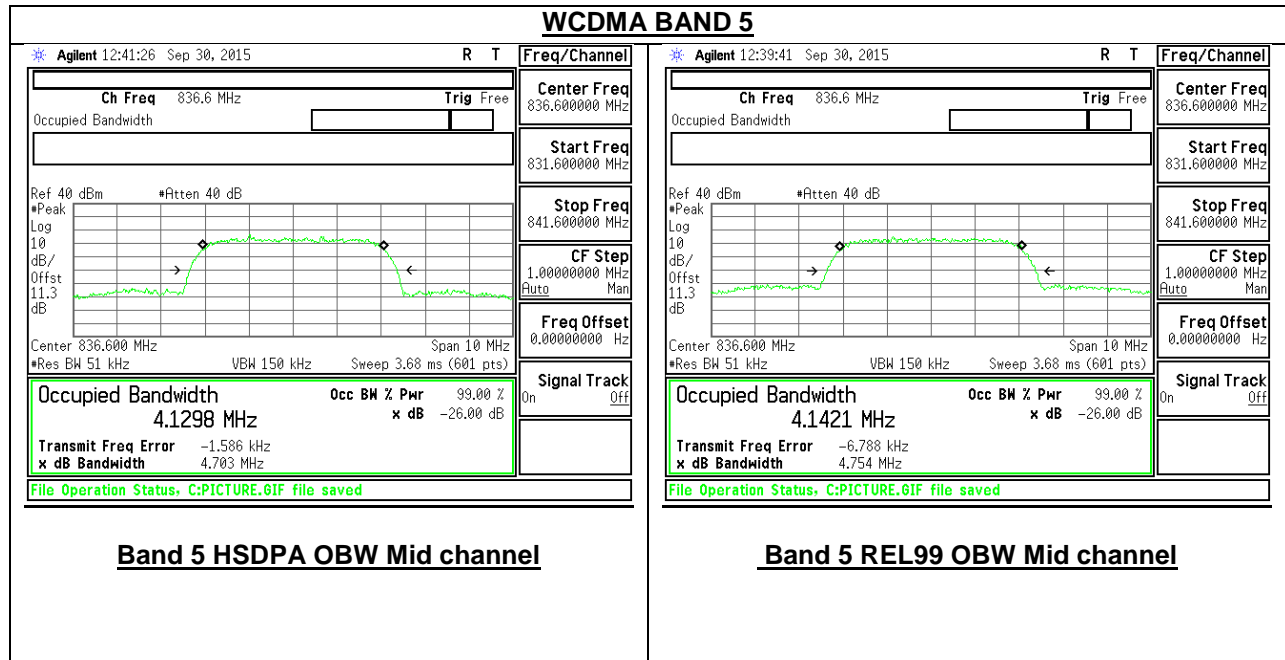

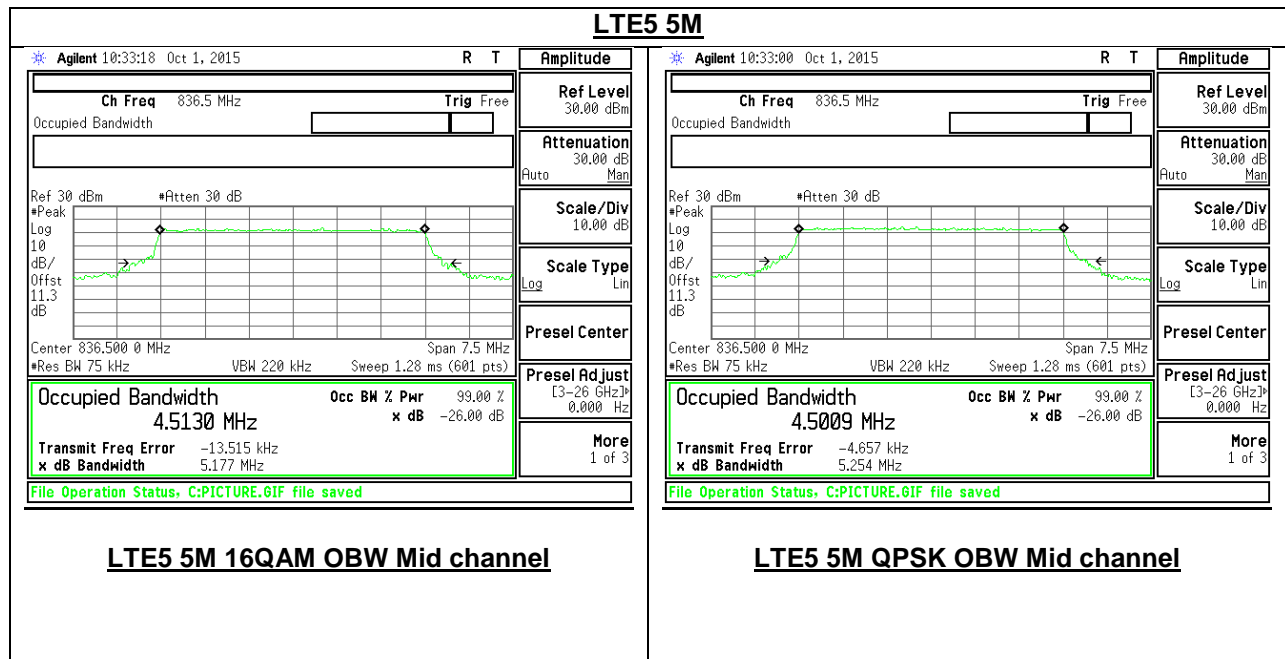
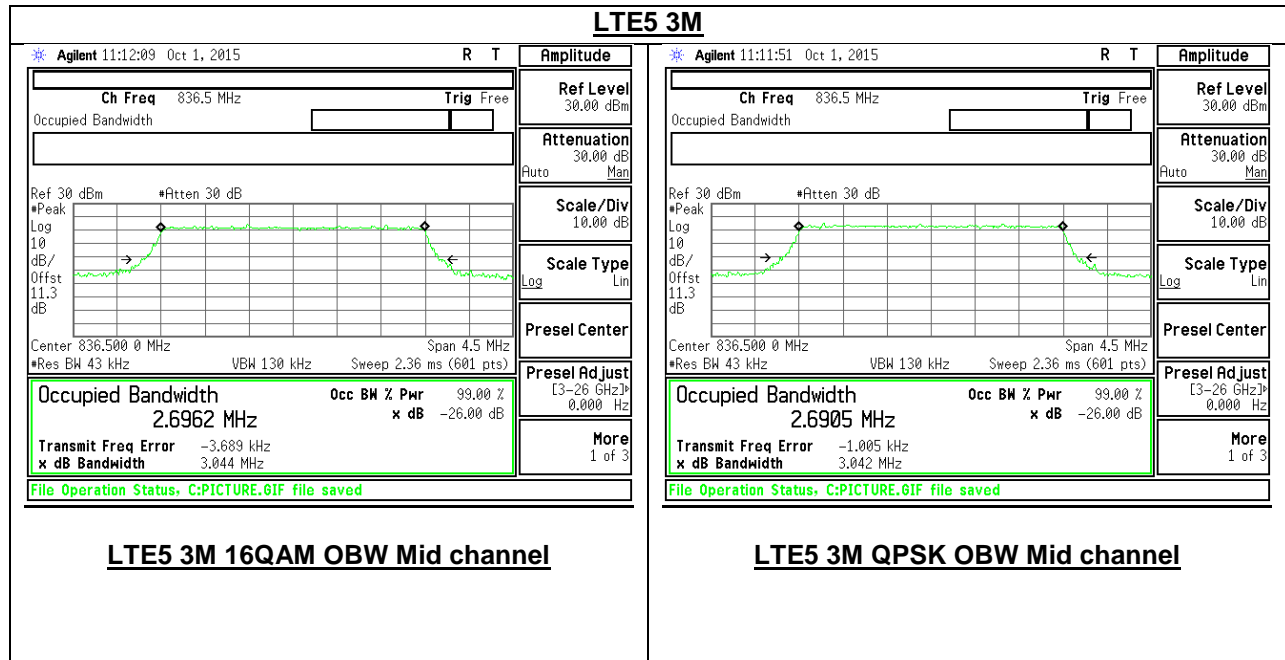

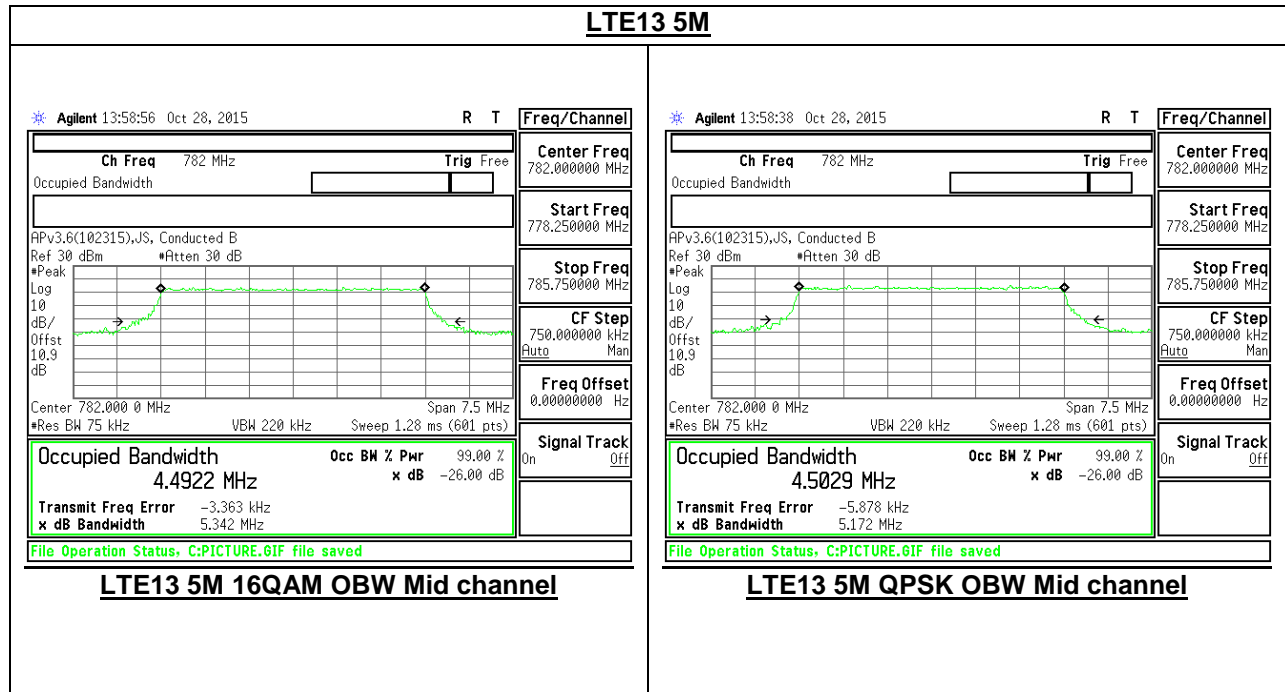
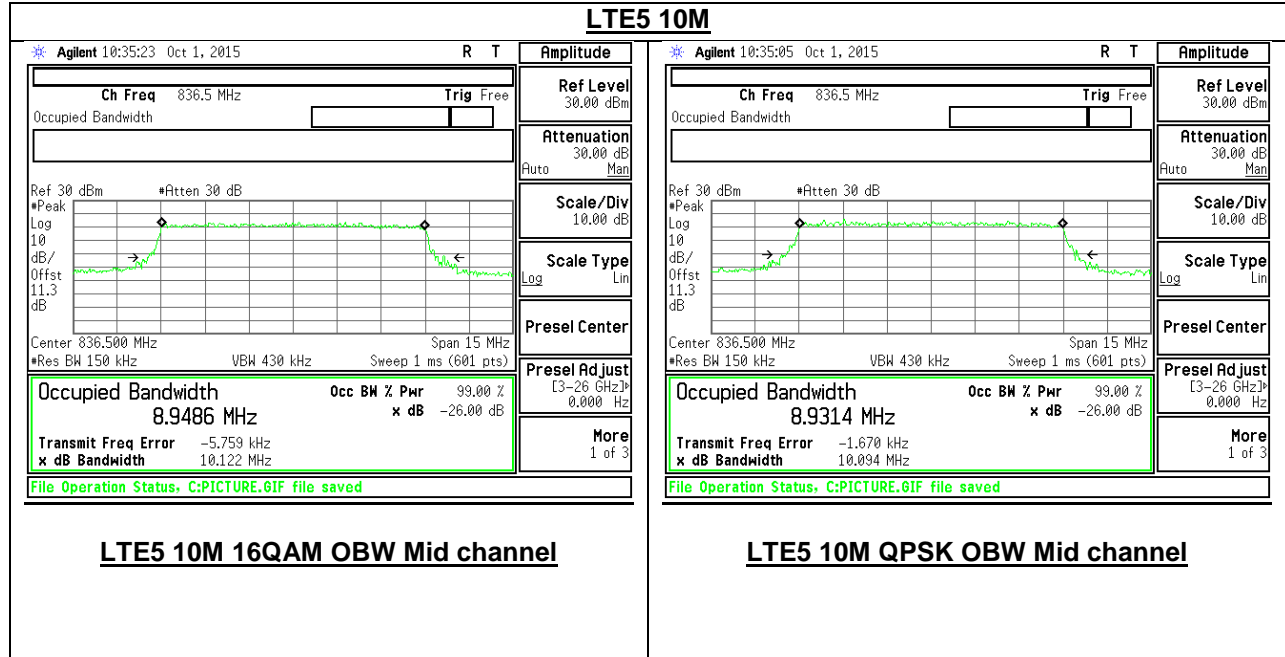

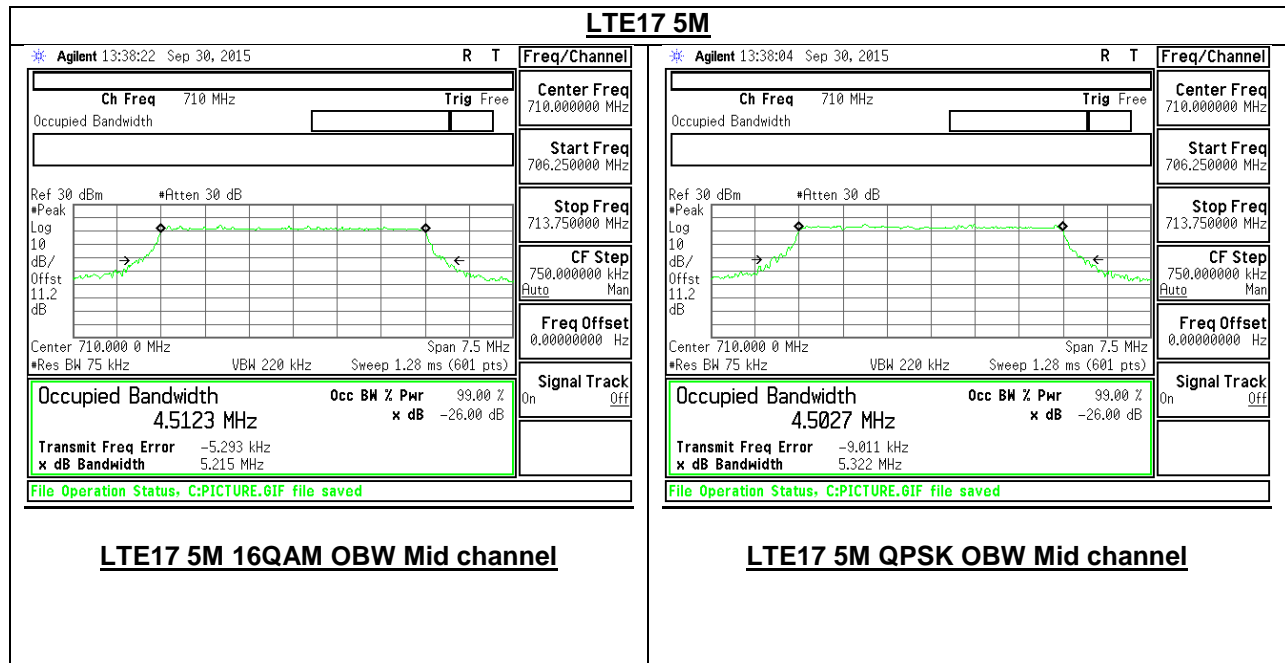
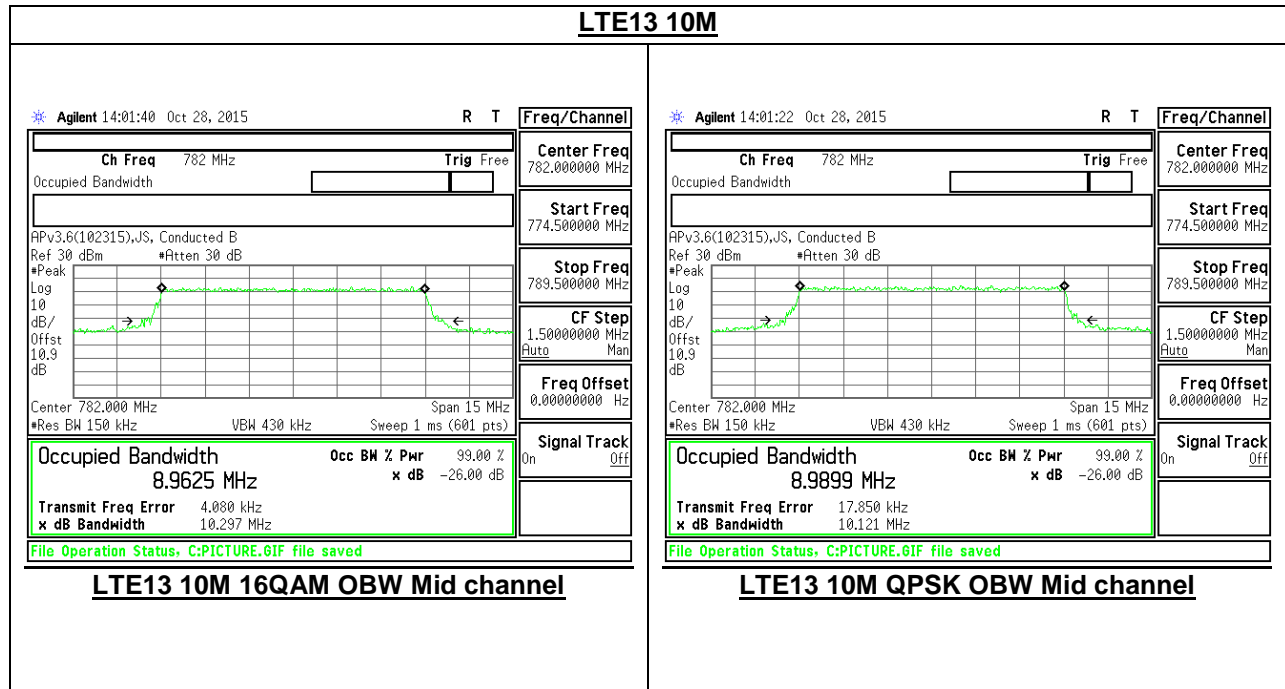

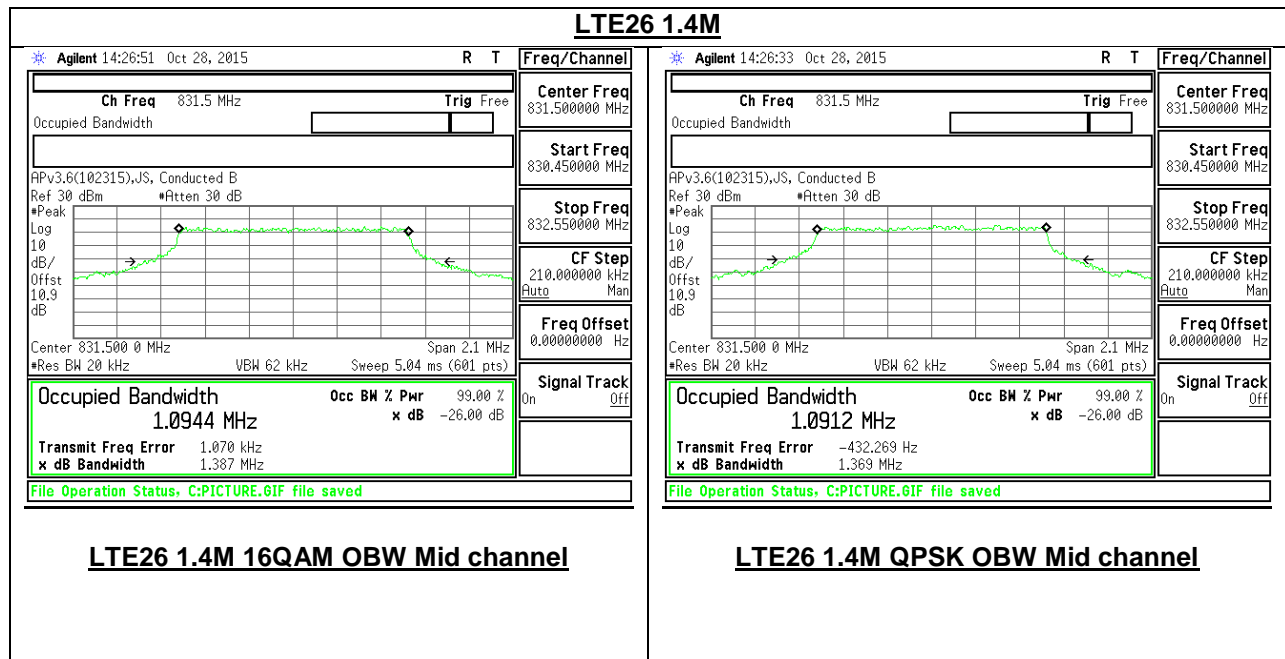
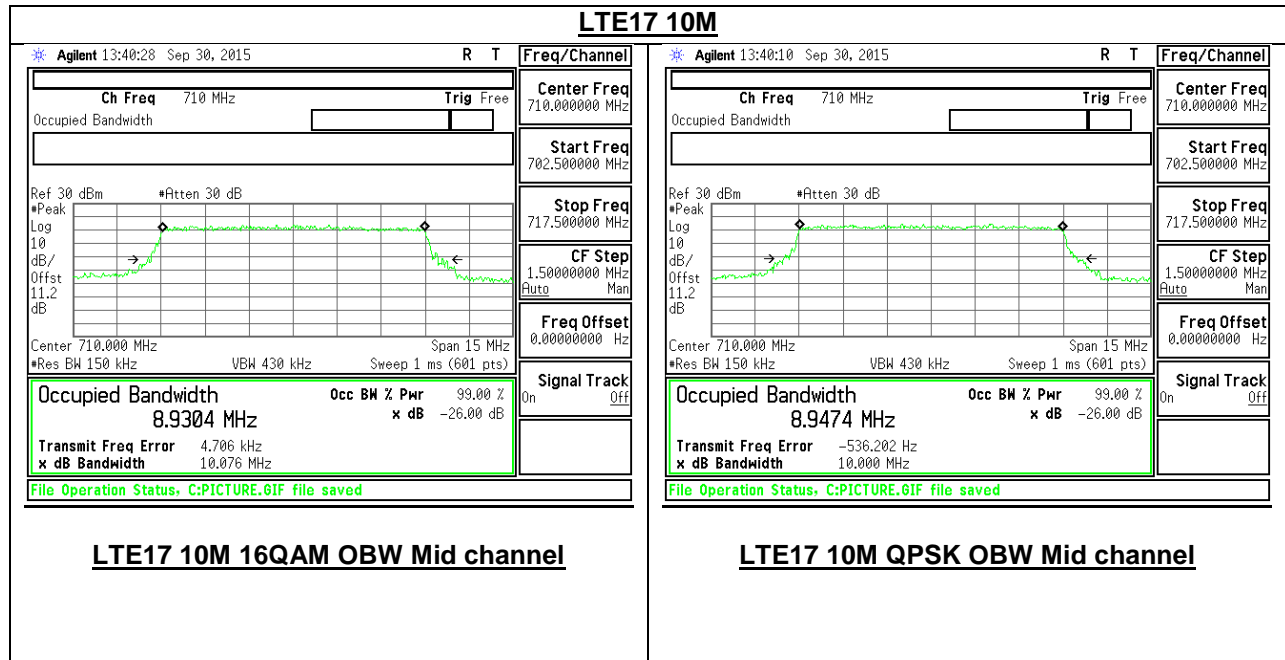

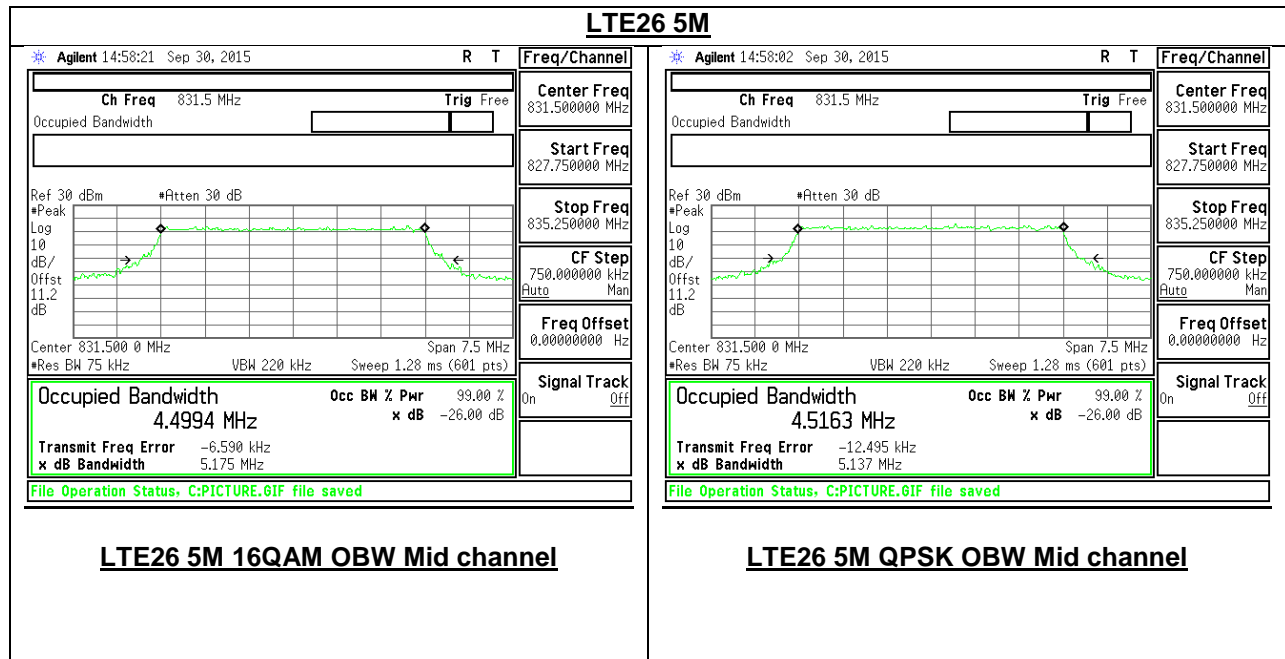
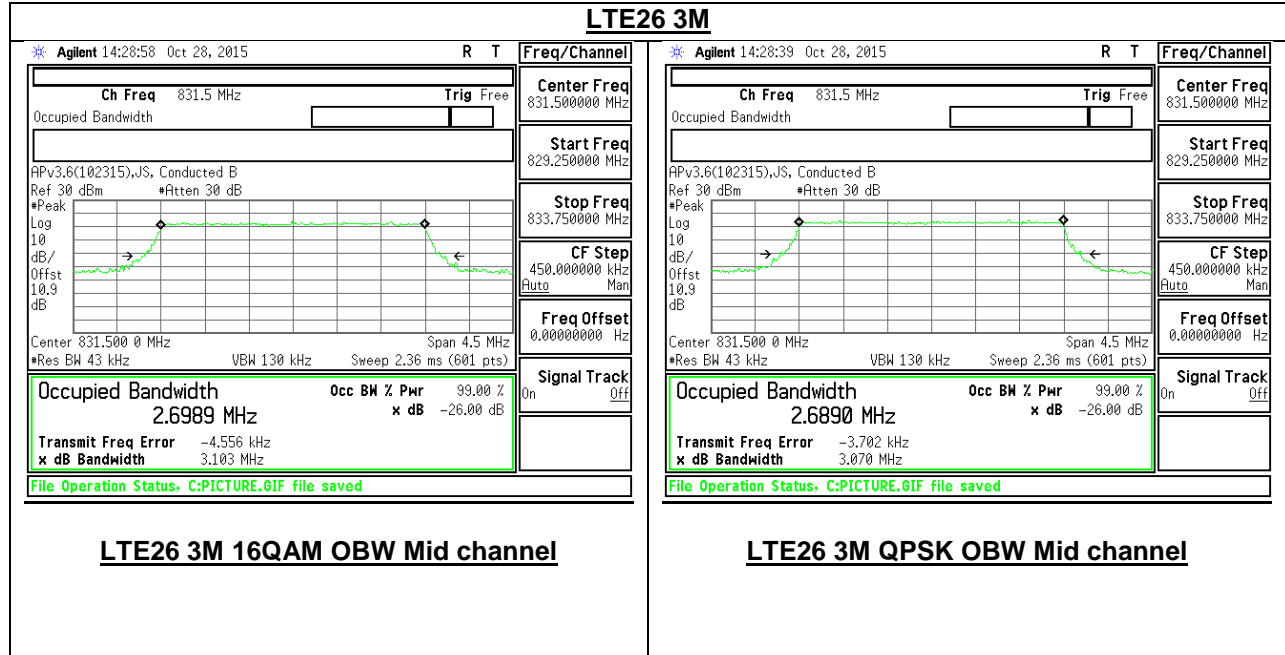

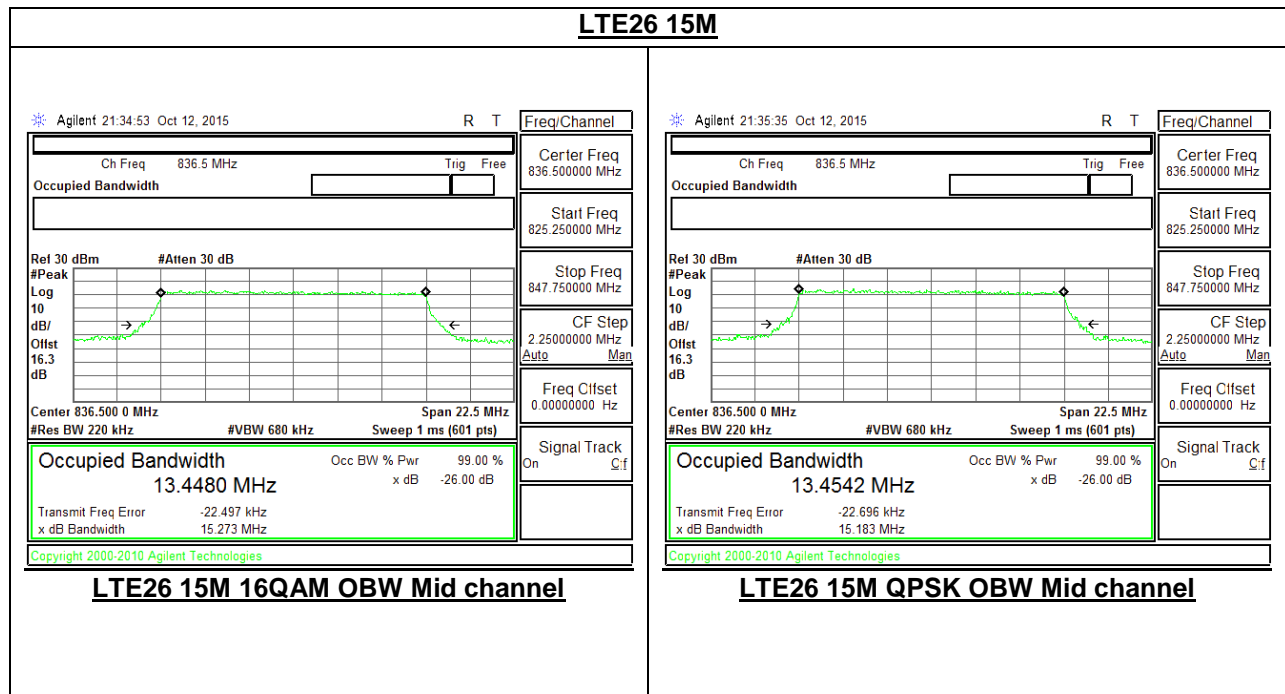
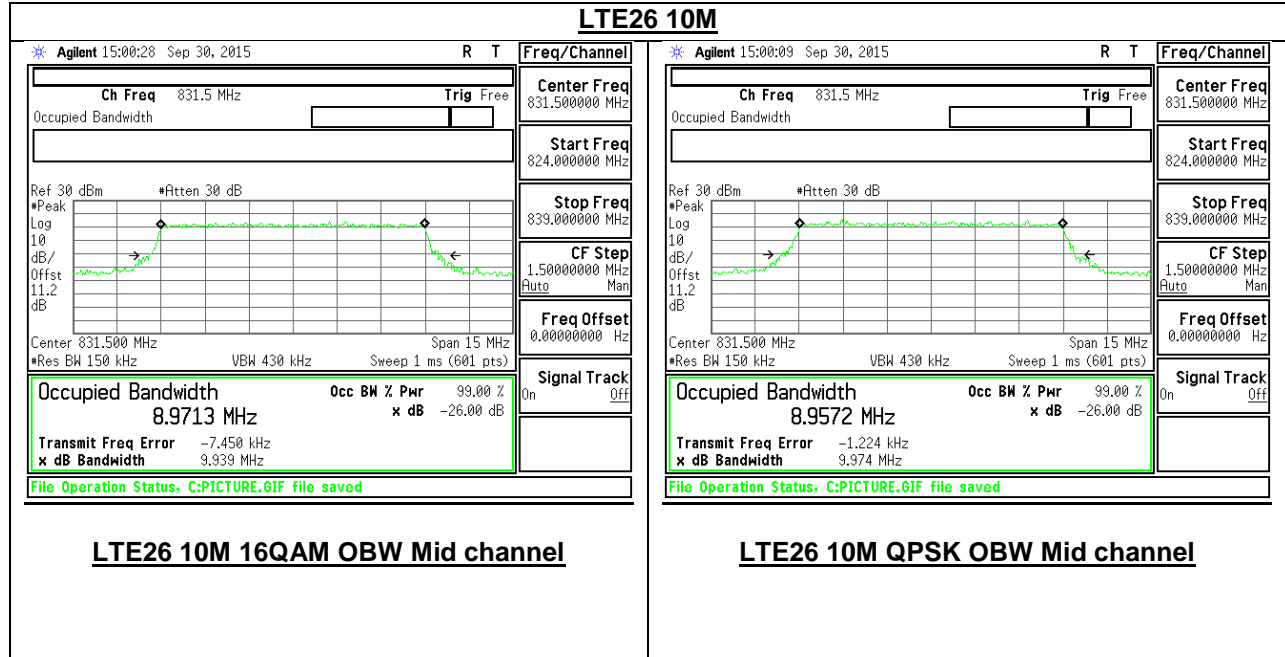

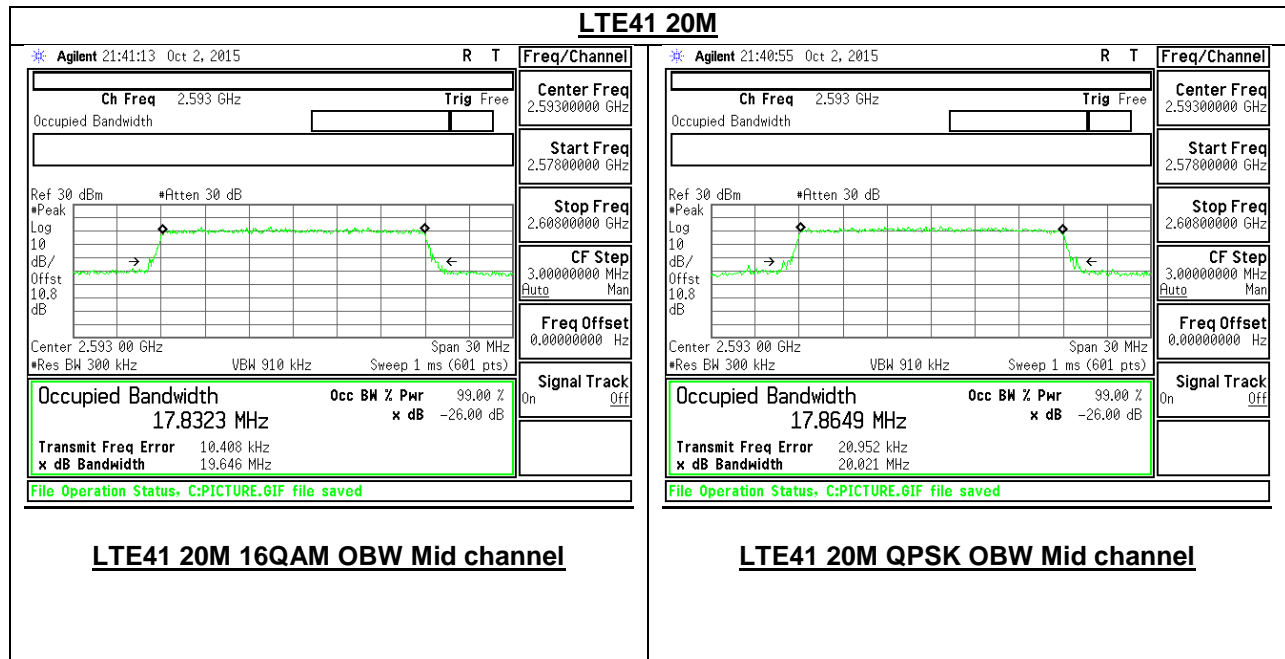
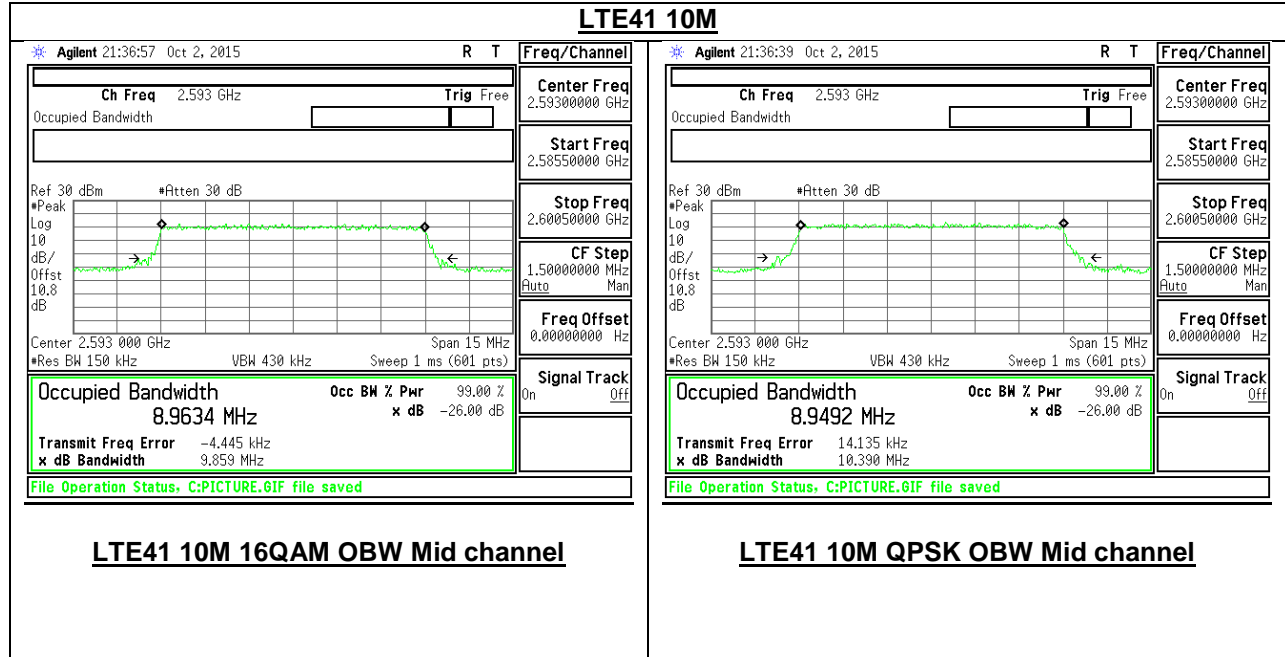

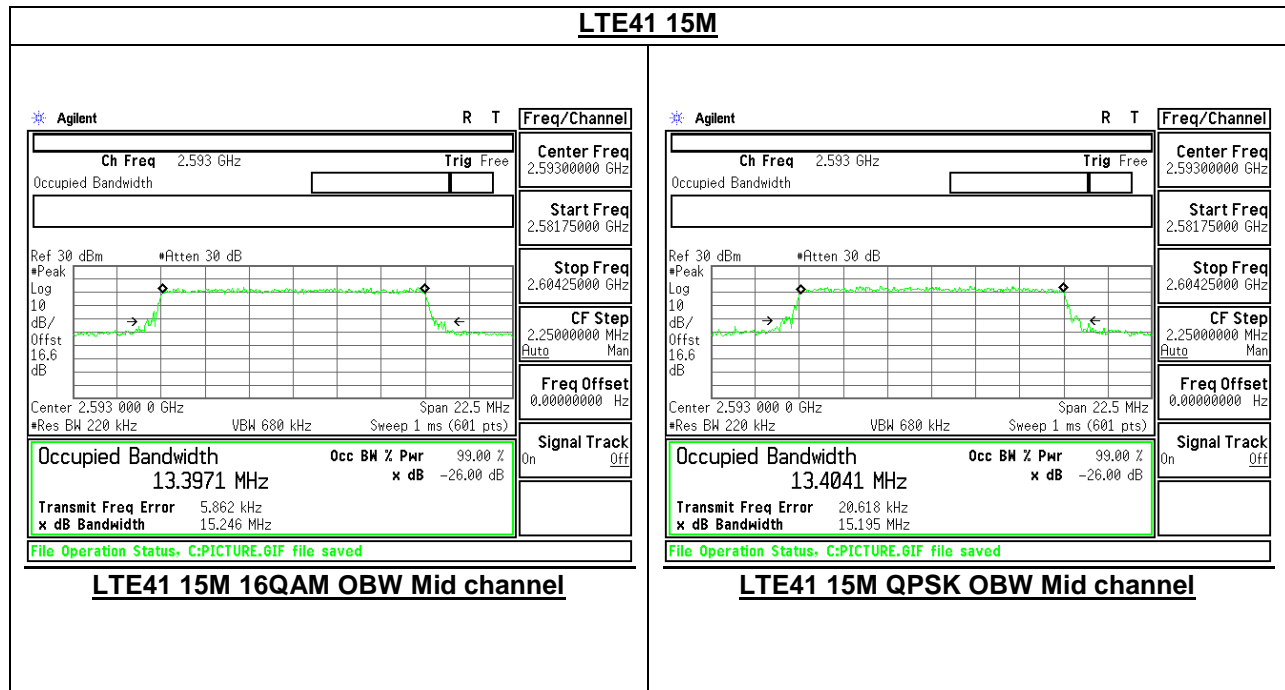
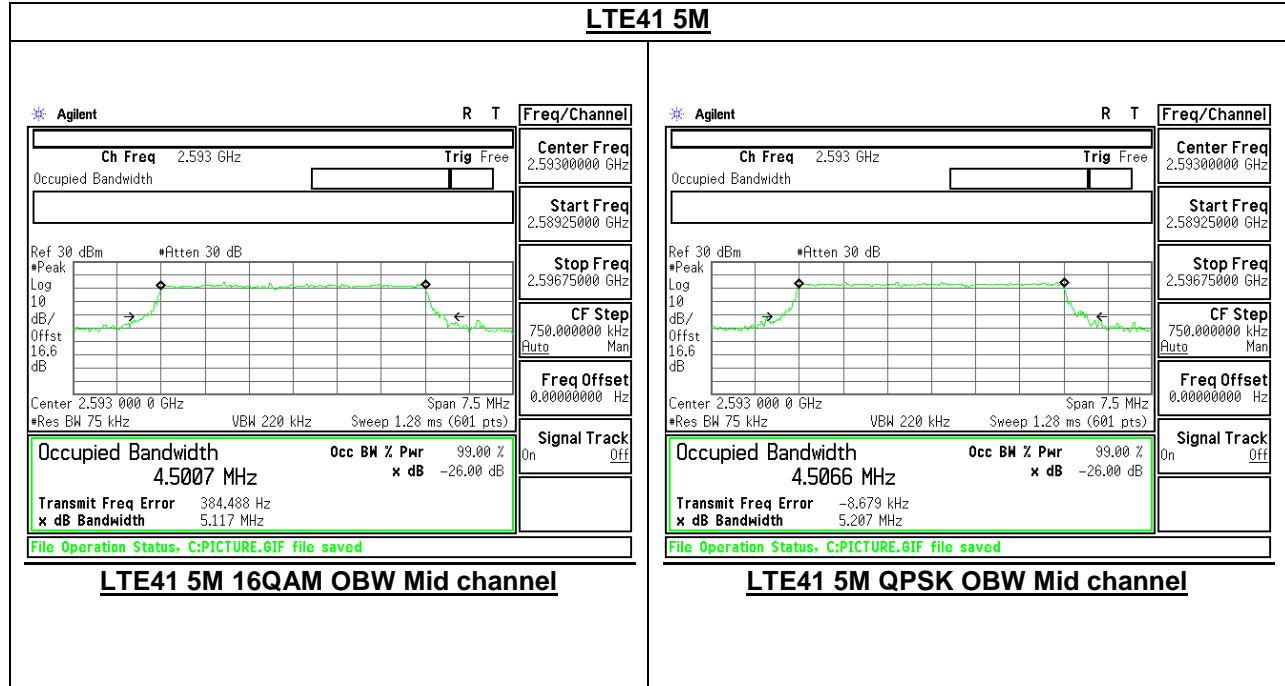

10.2. BAND EDGE EMISSIONS

RULE PART(S)

FCC: §22.359, §24.238, §27.53 and §90.691

LIMITS

The power of any emission outside of the authorized operating frequency ranges must be attenuated below the transmitting power (P) by a factor of at least $43 + 10 \log (P)$ dB.

Part 27: (m)(4) (4) For mobile digital stations, the attenuation factor shall be not less than $40 + 10 \log (P)$ dB on all frequencies between the channel edge and 5 megahertz from the channel edge, $43 + 10 \log (P)$ dB on all frequencies between 5 megahertz and X megahertz from the channel edge, and $55 + 10 \log (P)$ dB on all frequencies more than X megahertz from the channel edge, where X is the greater of 6 megahertz or the actual emission bandwidth as defined in paragraph (m)(6) of this section. In addition, the attenuation factor shall not be less than $43 + 10 \log (P)$ dB on all frequencies between 2490.5 MHz and 2496 MHz and $55 + 10 \log (P)$ dB at or below 2490.5 MHz. Mobile Satellite Service licensees operating on frequencies below 2495 MHz may also submit a documented interference complaint against BRS licensees operating on channel BRS Channel 1 on the same terms and conditions as adjacent channel BRS or EBS licensees.

Part 90:

(a)(1) For any frequency removed from the EA licensee's frequency block by up to and including 37.5 kHz, the power of any emission shall be attenuated below the transmitter power (P) in watts by at least $116 \log_{10}(f/6.1)$ decibels or $50 + 10 \log_{10}(P)$ decibels or 80 decibels, whichever is the lesser attenuation, where f is the frequency removed from the center of the outer channel in the block in kilohertz and where f is greater than 12.5 kHz.

(a)(2) For any frequency removed from the EA licensee's frequency block greater than 37.5 kHz, the power of any emission shall be attenuated below the transmitter power (P) in watts by at least $43 + 10 \log_{10}(P)$ decibels or 80 decibels, whichever is the lesser attenuation, where f is the frequency removed from the center of the outer channel in the block in kilohertz and where f is greater than 37.5 kHz. {NOTE: Use 100 kHz reference bandwidth.}

TEST PROCEDURE

Per KDB 971168 D01 Power Meas License Digital Systems v02r02

The transmitter output was connected to an Agilent 8960 or a CMW500 Test Set and configured to operate at maximum power. The band edge emissions were measured at the required operating frequencies in each band on the Spectrum Analyzer.

MODES TESTED

GSM, WCDMA, and LTE

RESULTS

Note: GSM reading need add 9dB DCCF factor due to duty cycle is 12.5% during test.

LTE 41 Reading need apply 4.44dB duty cycle factor ($20 \log (6/10)$).

10.2.1. BAND EDGE PLOTS

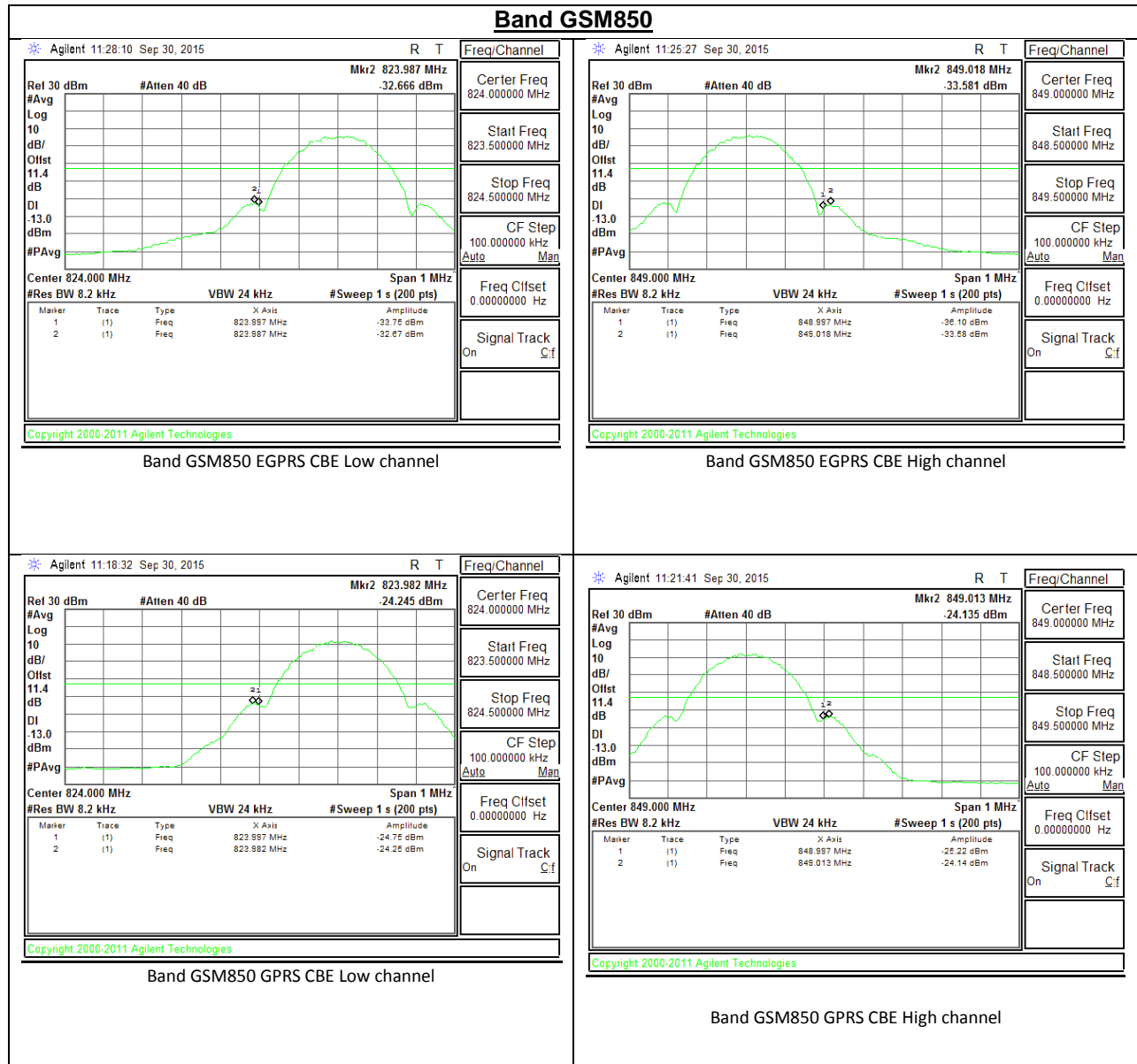

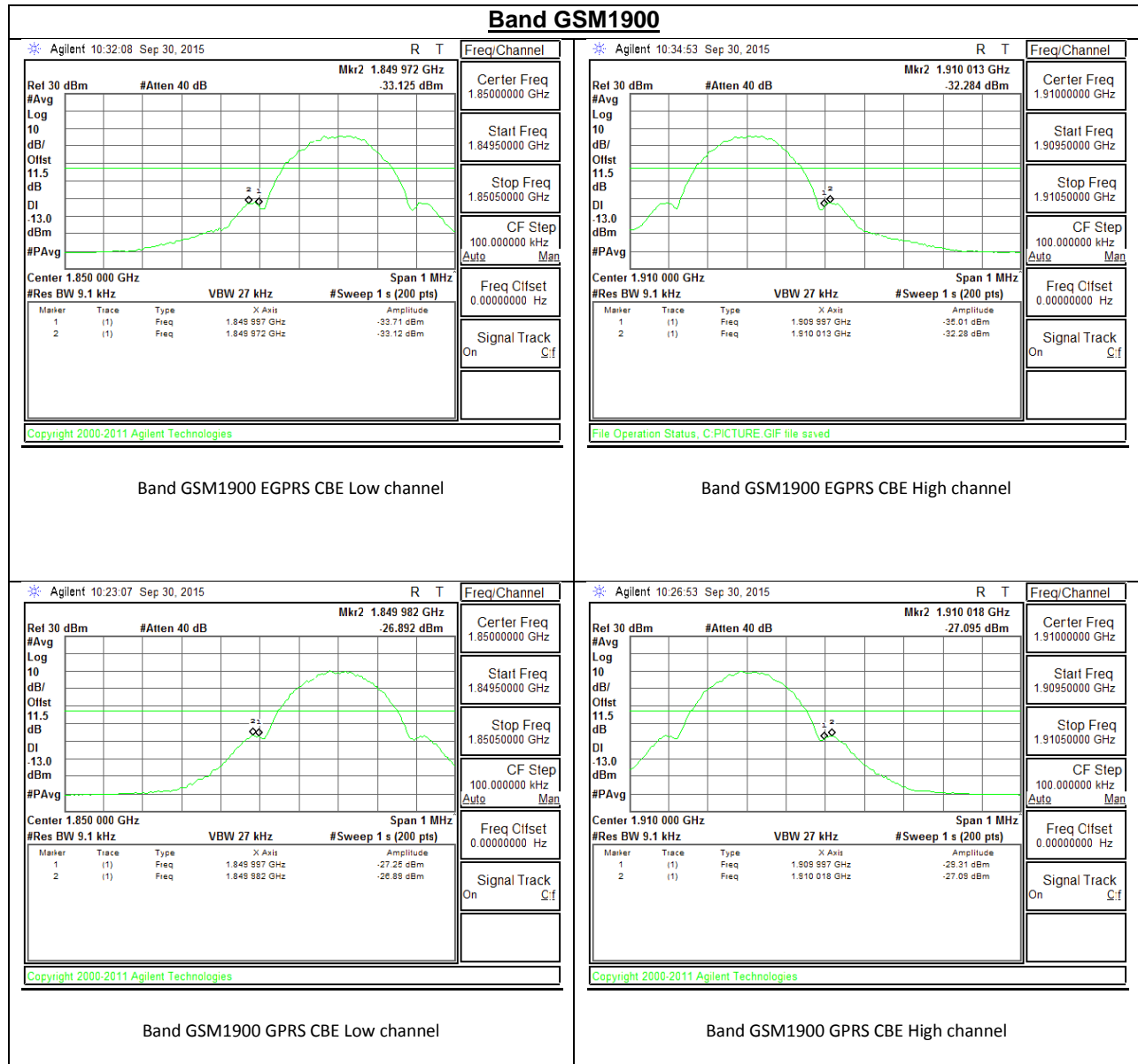

WCDMA 5

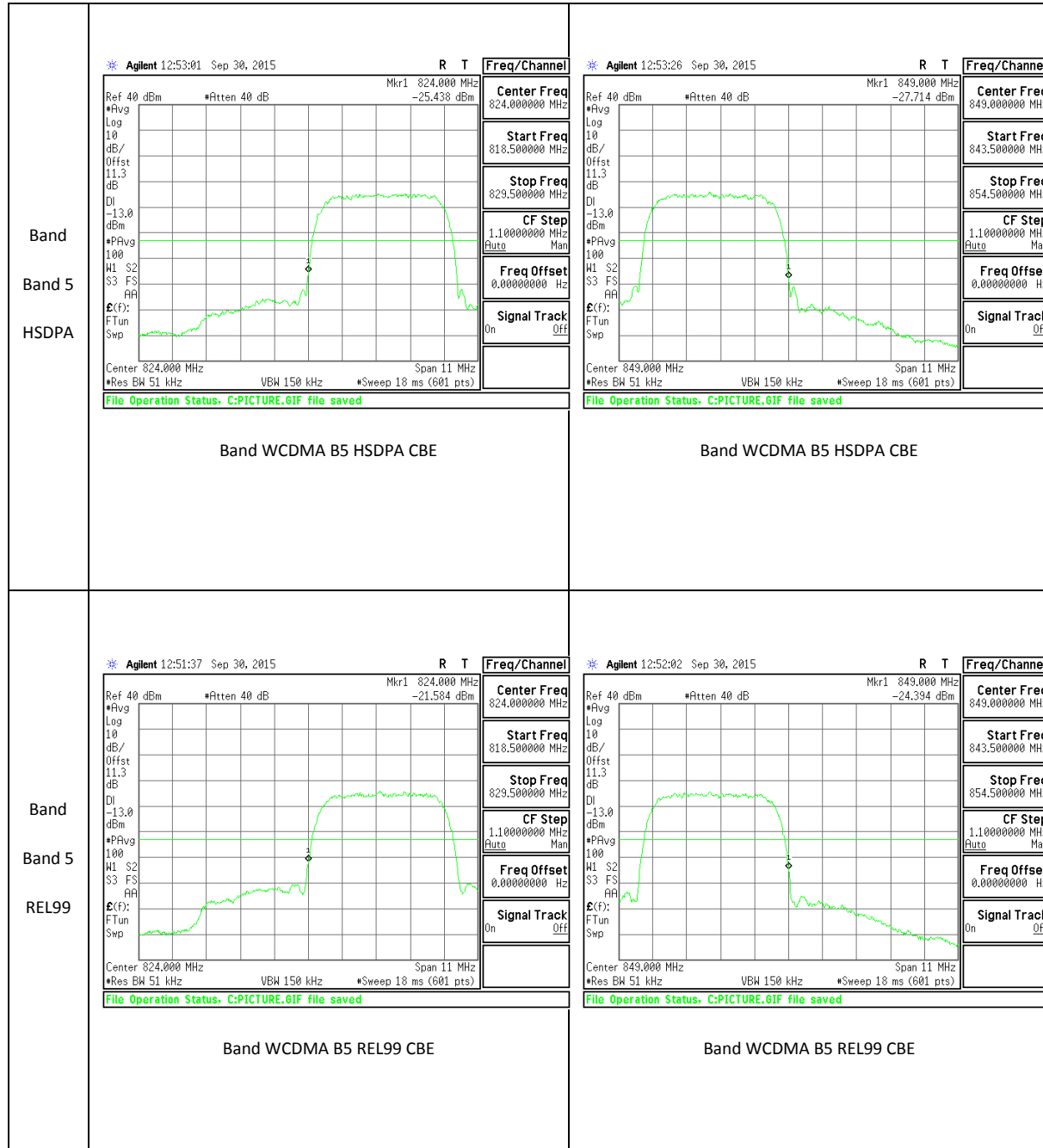

LTES

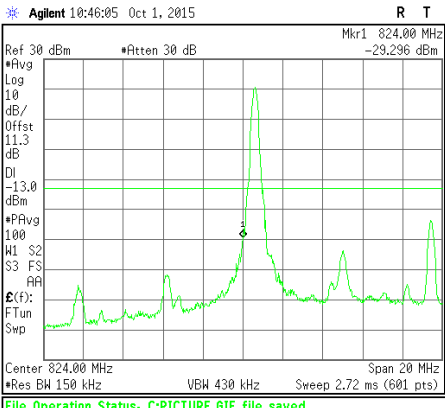
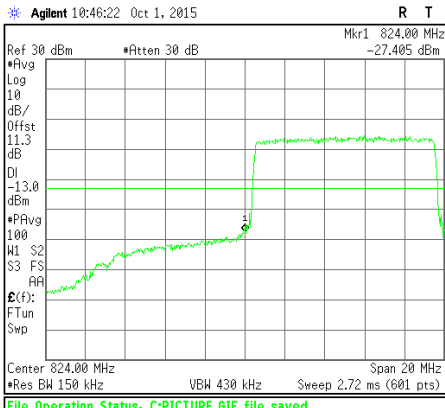
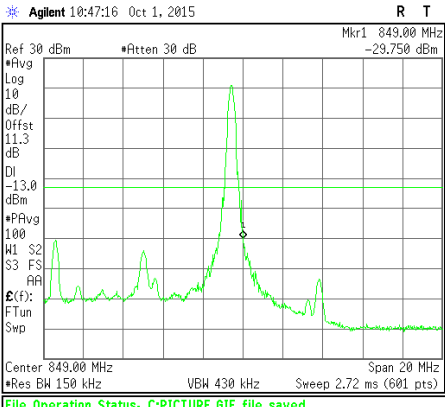
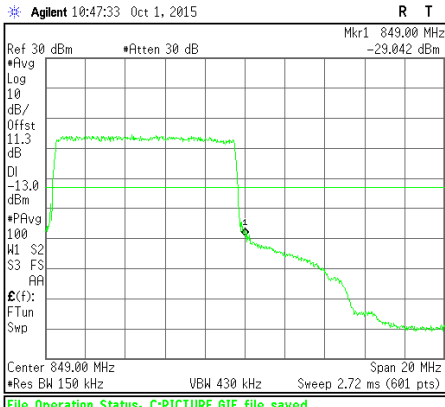
<p>Band LTES 10MHz 16QAM</p>	 <p>Agilent 10:46:05 Oct 1, 2015</p> <p>Center 824.00 MHz Res BW 150 kHz VBW 430 kHz Sweep 2.72 ms (601 pts)</p> <p>File Operation Status, C:PICTURE.GIF file saved</p>	 <p>Agilent 10:46:22 Oct 1, 2015</p> <p>Center 824.00 MHz Res BW 150 kHz VBW 430 kHz Sweep 2.72 ms (601 pts)</p> <p>File Operation Status, C:PICTURE.GIF file saved</p>
	<p>Band LTE5 10MHz CBE 16QAM Low Channel 1RB.gif</p>	<p>Band LTE5 10MHz CBE 16QAM Low Channel FRB.gif</p>
<p>Band LTES 10MHz 16QAM</p>	 <p>Agilent 10:47:16 Oct 1, 2015</p> <p>Center 849.00 MHz Res BW 150 kHz VBW 430 kHz Sweep 2.72 ms (601 pts)</p> <p>File Operation Status, C:PICTURE.GIF file saved</p>	 <p>Agilent 10:47:33 Oct 1, 2015</p> <p>Center 849.00 MHz Res BW 150 kHz VBW 430 kHz Sweep 2.72 ms (601 pts)</p> <p>File Operation Status, C:PICTURE.GIF file saved</p>
	<p>Band LTE5 10MHz CBE 16QAM High Channel 1RB.gif</p>	<p>Band LTE5 10MHz CBE 16QAM High Channel FRB.gif</p>

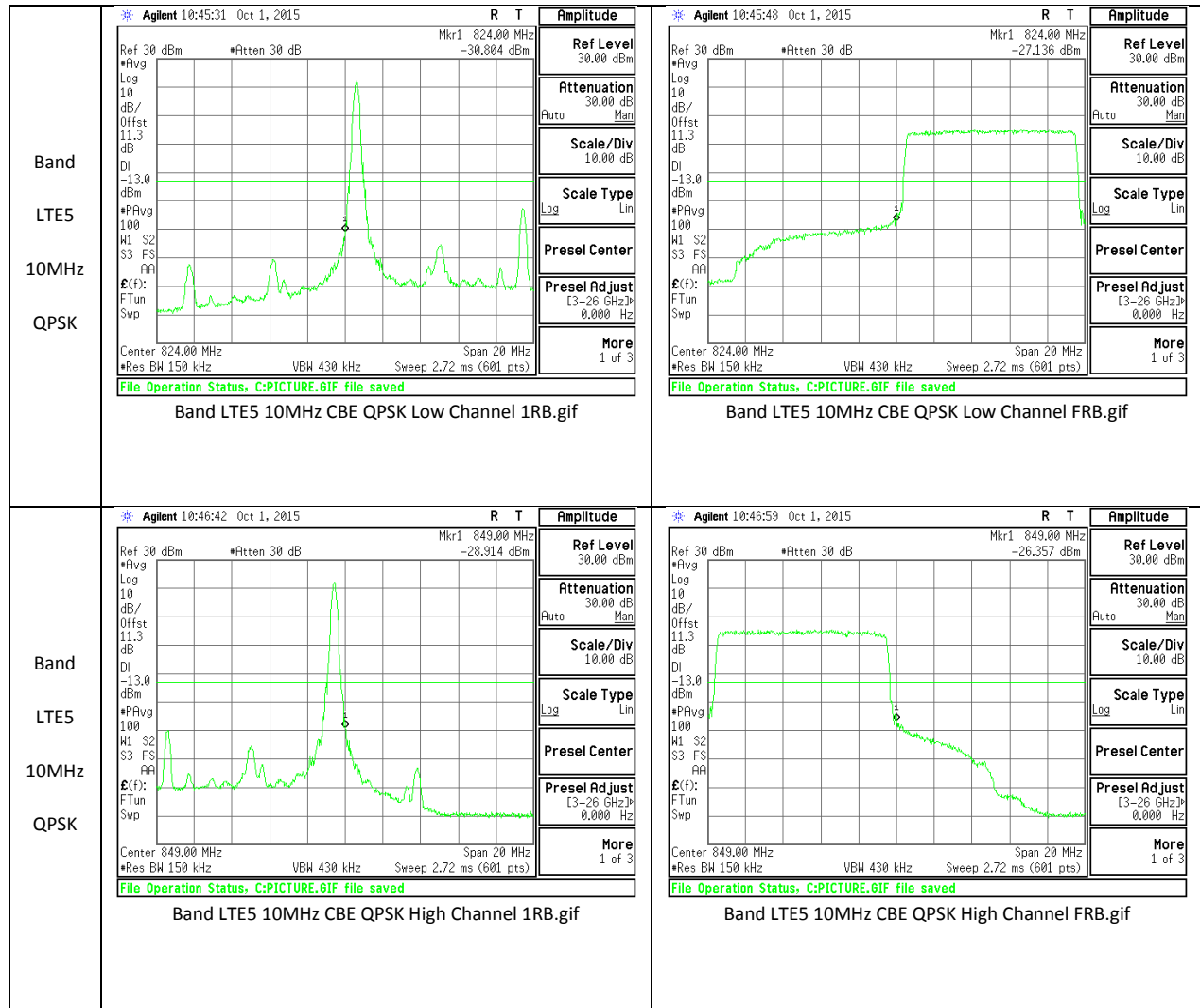

<p>Band LTE5 5MHz 16QAM</p>	<p>Agilent 10:43:36 Oct 1, 2015</p> <p>Ref 30 dBm #Atten 30 dB Mkr1 824.000 MHz -21.884 dBm</p> <p>Amplitude Ref Level 30.00 dBm Attenuation 30.00 dB Scale/Div 10.00 dB Scale Type Lin Presel Center Presel Ad Just [3-28 GHz] 0.000 Hz More 1 of 3</p> <p>File Operation Status, C:PICTURE.GIF file saved</p> <p>Band LTE5 5MHz CBE 16QAM Low Channel 1RB.gif</p>	<p>Agilent 10:43:53 Oct 1, 2015</p> <p>Ref 30 dBm #Atten 30 dB Mkr1 824.000 MHz -22.525 dBm</p> <p>Amplitude Ref Level 30.00 dBm Attenuation 30.00 dB Scale/Div 10.00 dB Scale Type Lin Presel Center Presel Ad Just [3-28 GHz] 0.000 Hz More 1 of 3</p> <p>File Operation Status, C:PICTURE.GIF file saved</p> <p>Band LTE5 5MHz CBE 16QAM Low Channel FRB.gif</p>
<p>Band LTE5 5MHz 16QAM</p>	<p>Agilent 10:44:46 Oct 1, 2015</p> <p>Ref 30 dBm #Atten 30 dB Mkr1 849.000 MHz -21.312 dBm</p> <p>Amplitude Ref Level 30.00 dBm Attenuation 30.00 dB Scale/Div 10.00 dB Scale Type Lin Presel Center Presel Ad Just [3-28 GHz] 0.000 Hz More 1 of 3</p> <p>File Operation Status, C:PICTURE.GIF file saved</p> <p>Band LTE5 5MHz CBE 16QAM High Channel 1RB.gif</p>	<p>Agilent 10:45:04 Oct 1, 2015</p> <p>Ref 30 dBm #Atten 30 dB Mkr1 849.000 MHz -24.627 dBm</p> <p>Amplitude Ref Level 30.00 dBm Attenuation 30.00 dB Scale/Div 10.00 dB Scale Type Lin Presel Center Presel Ad Just [3-28 GHz] 0.000 Hz More 1 of 3</p> <p>File Operation Status, C:PICTURE.GIF file saved</p> <p>Band LTE5 5MHz CBE 16QAM High Channel FRB.gif</p>

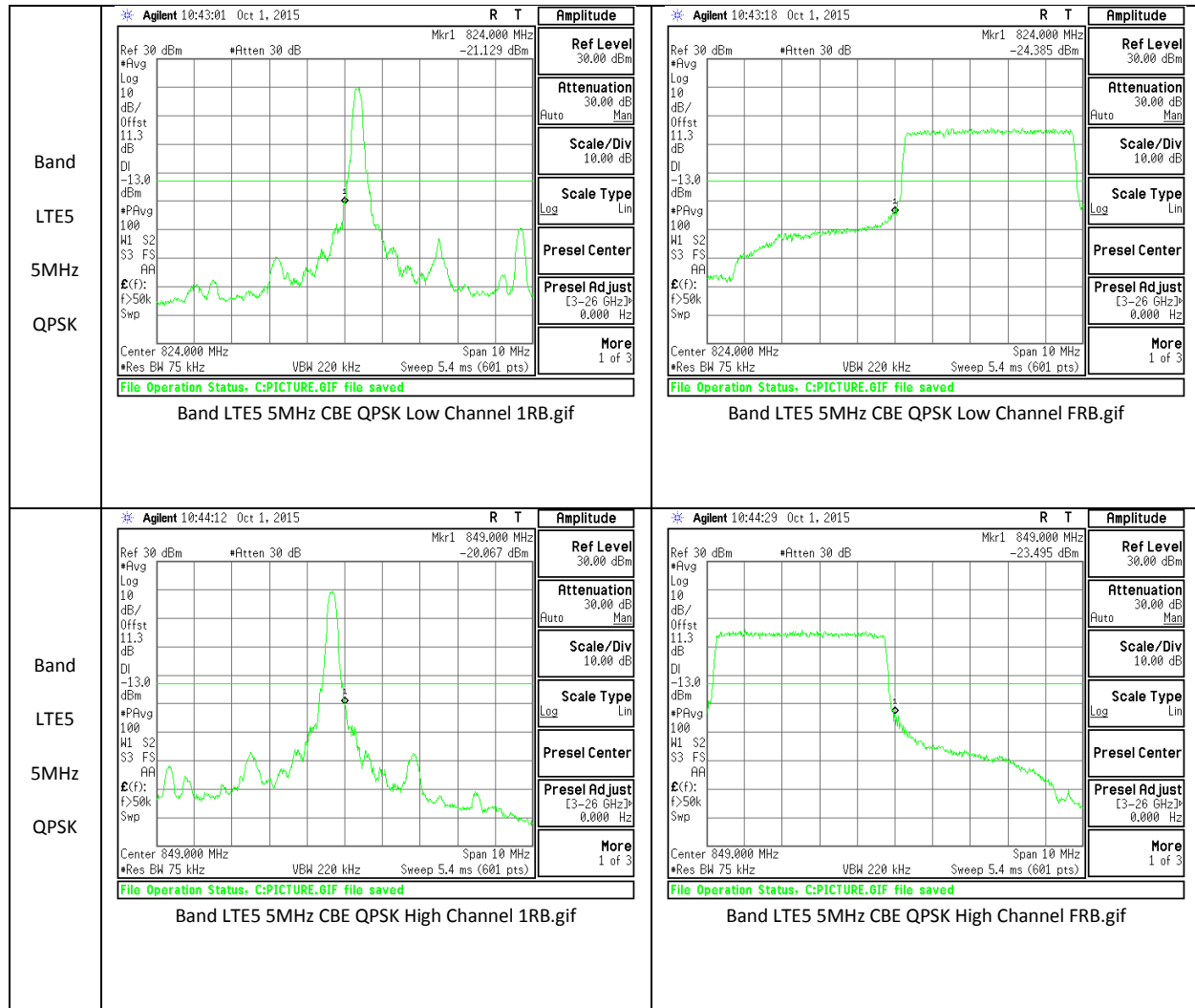

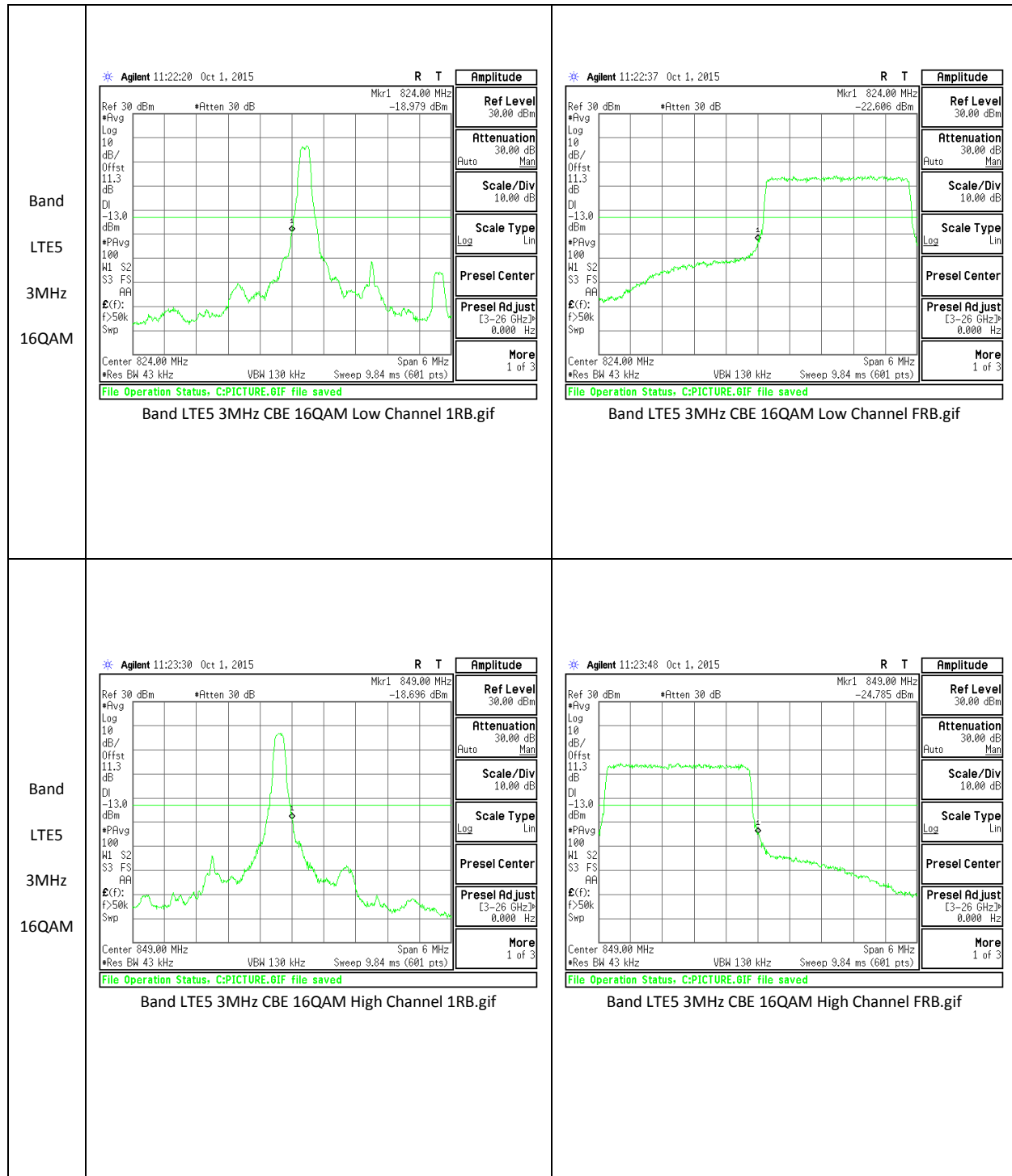

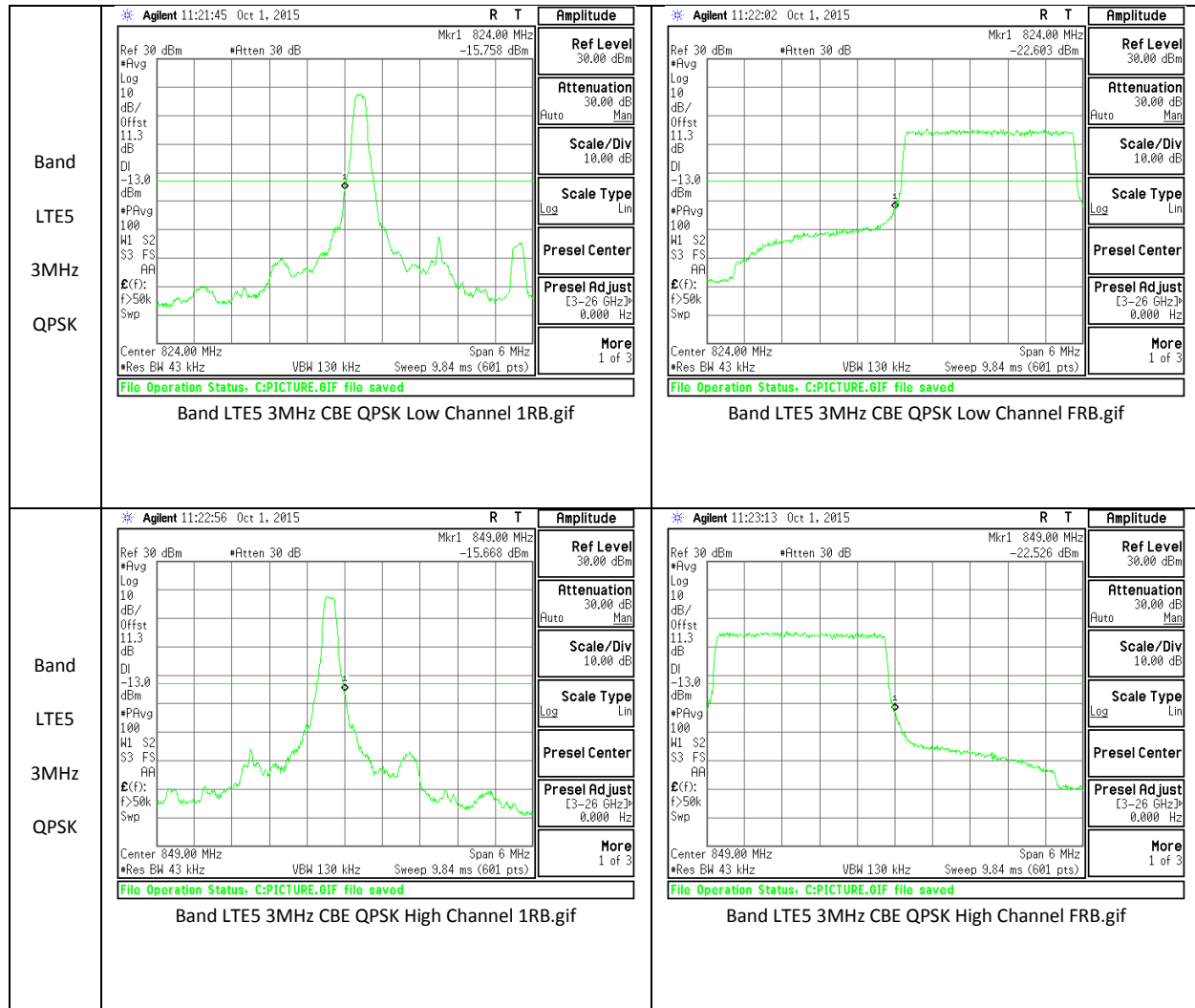

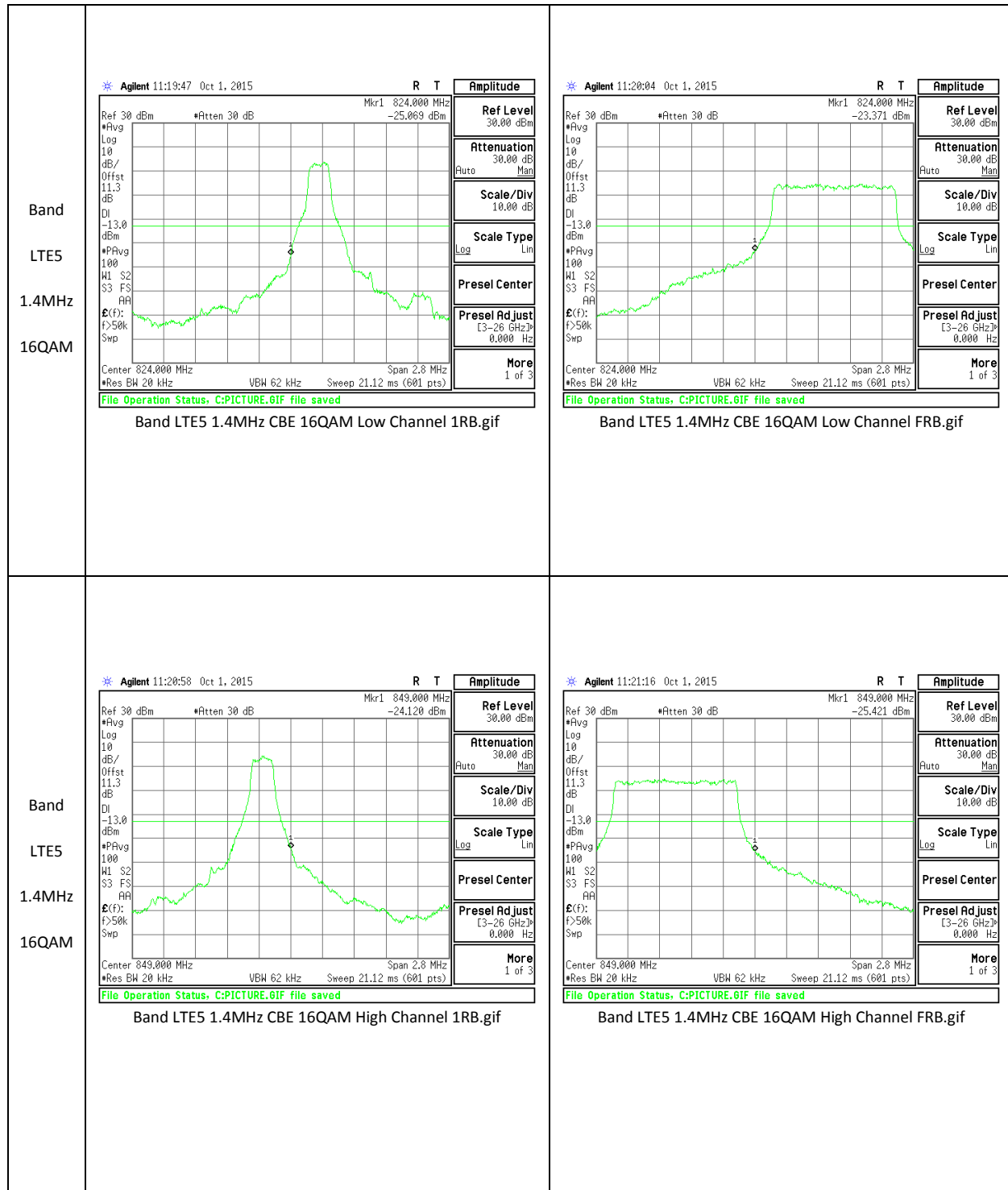

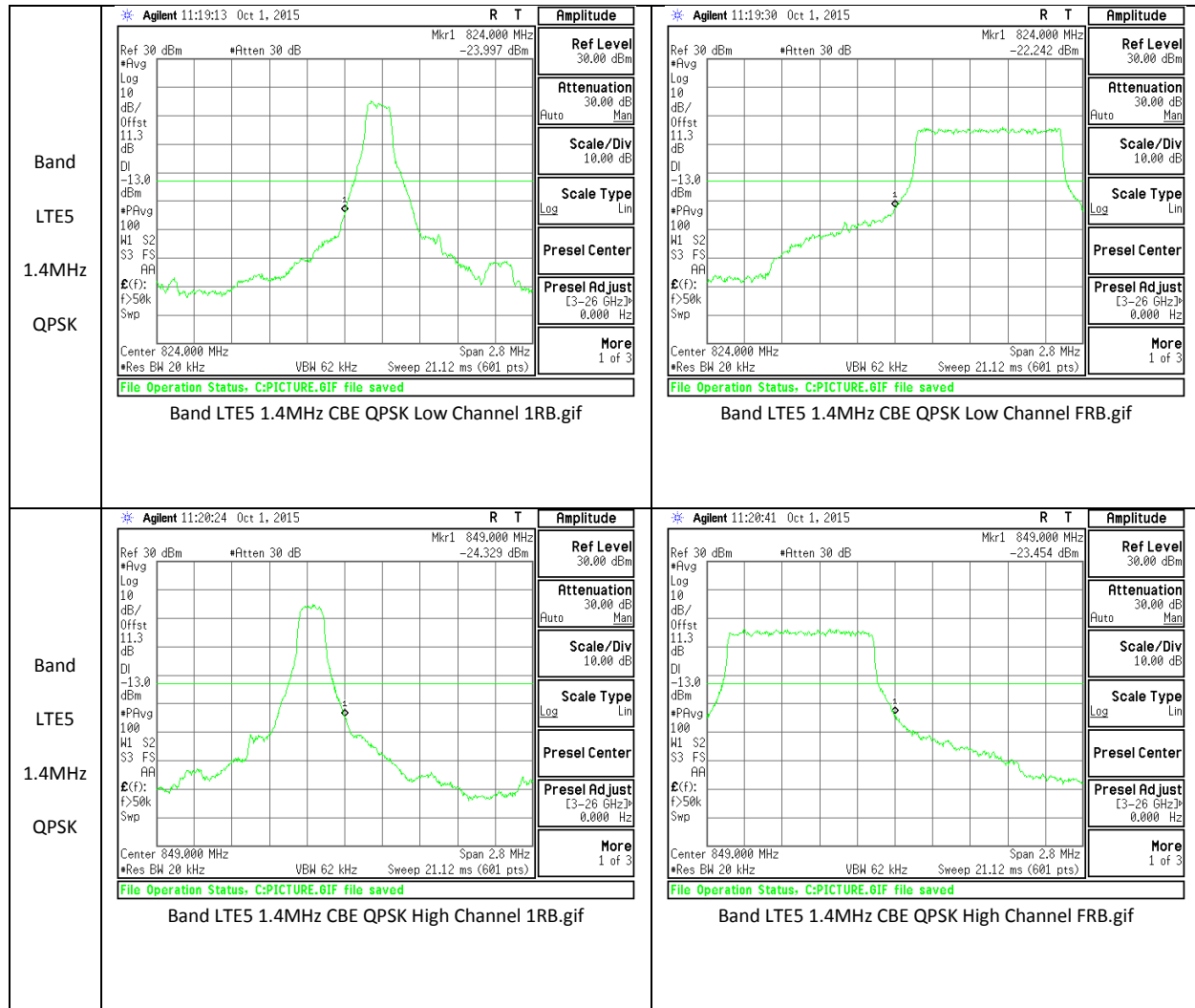

LTE13

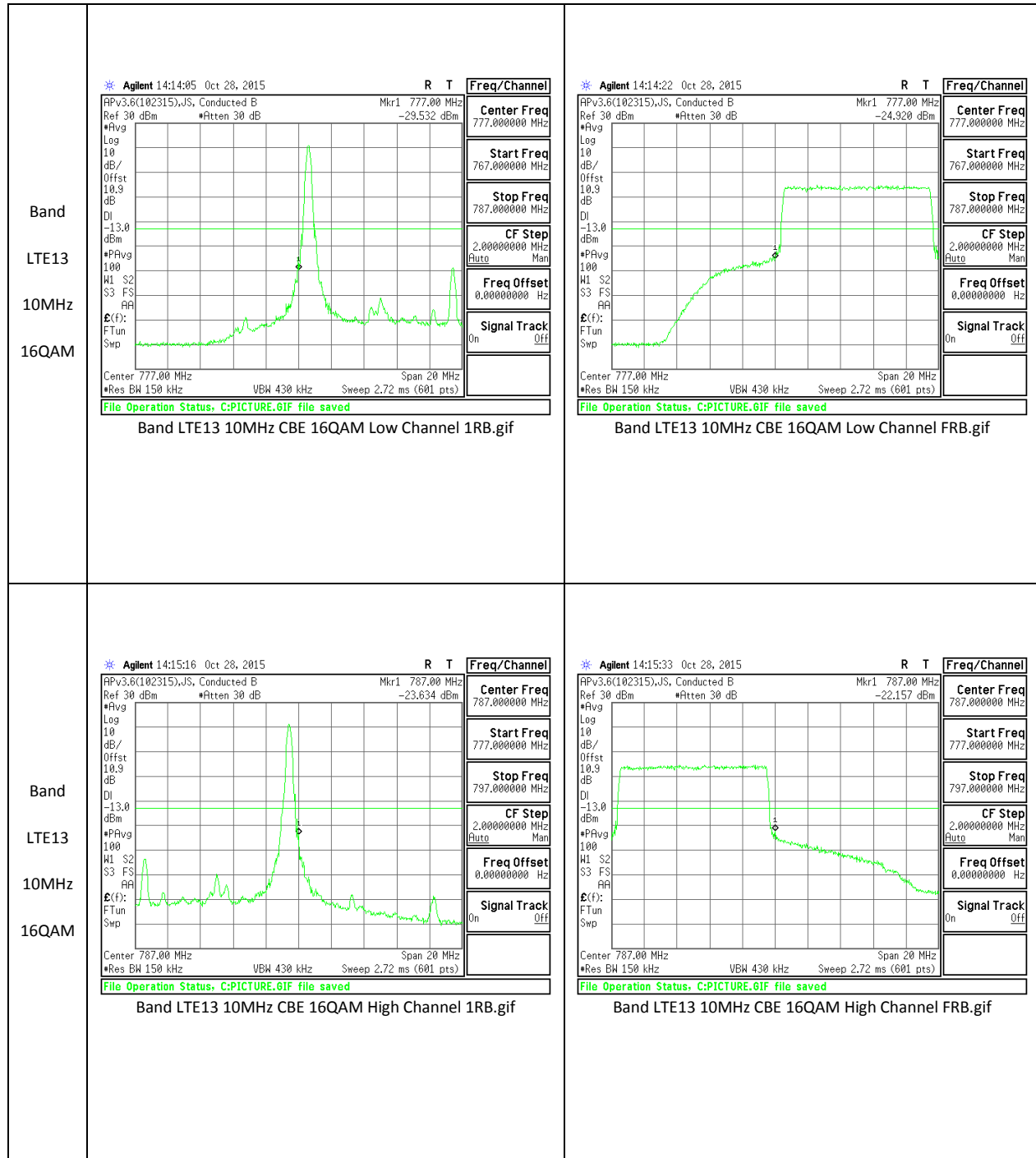

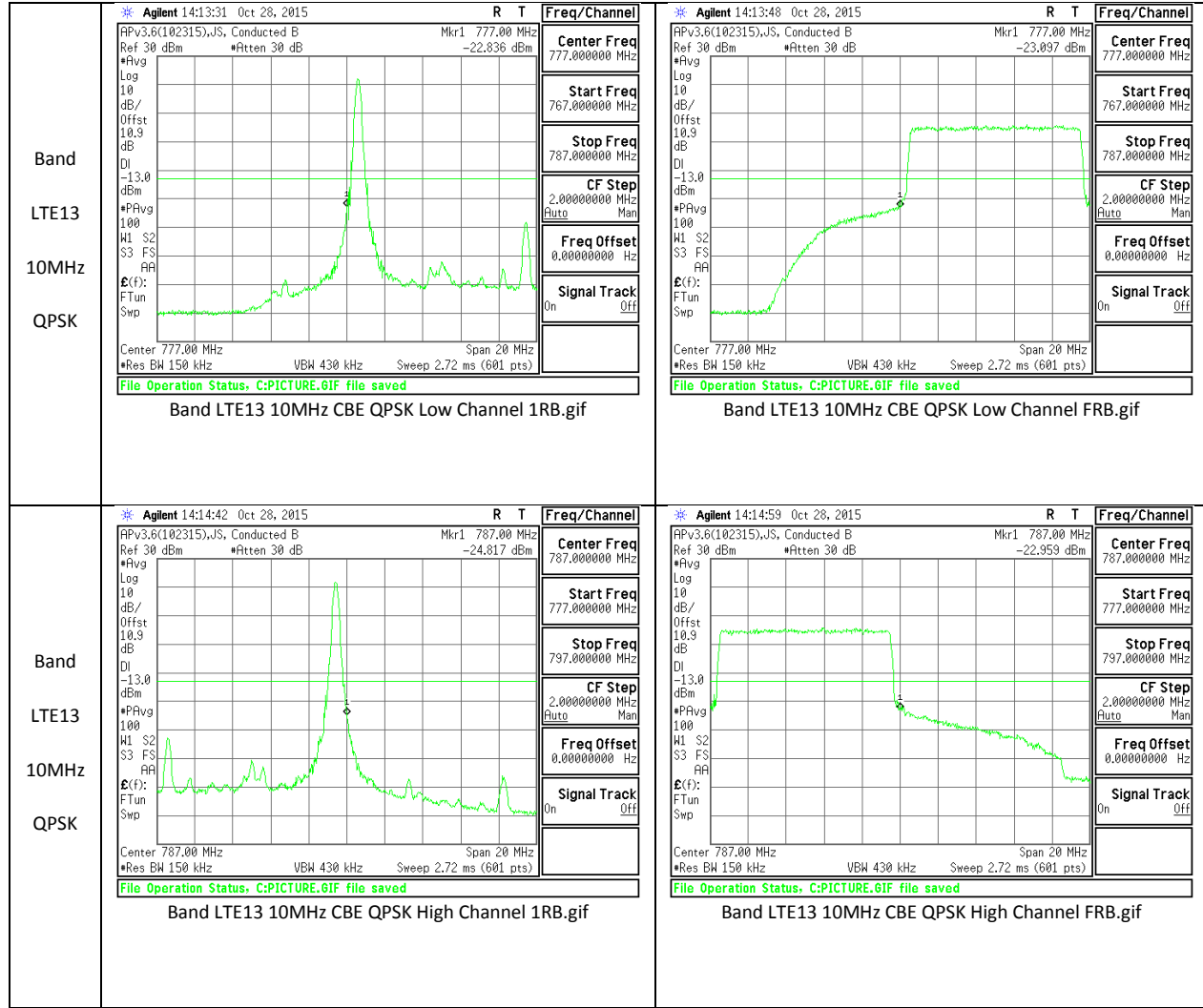

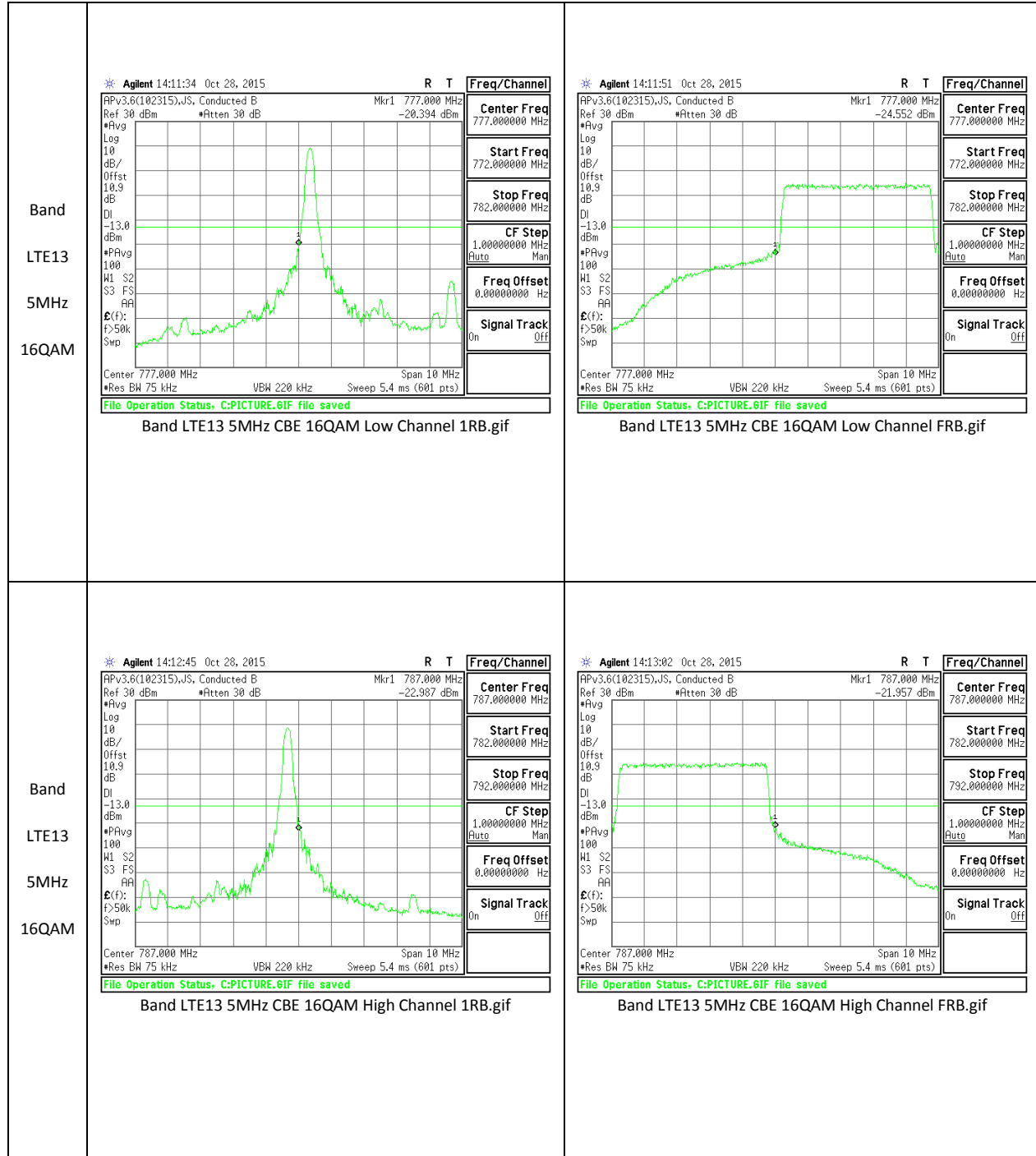

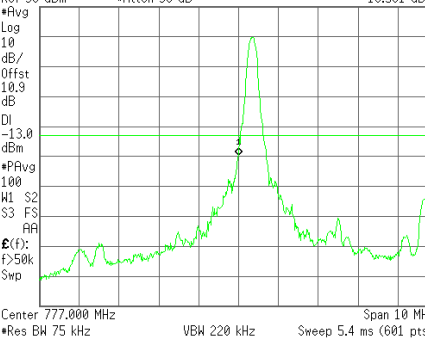
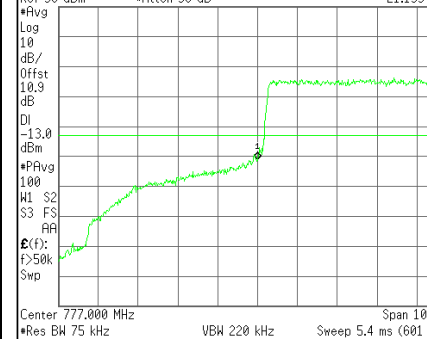
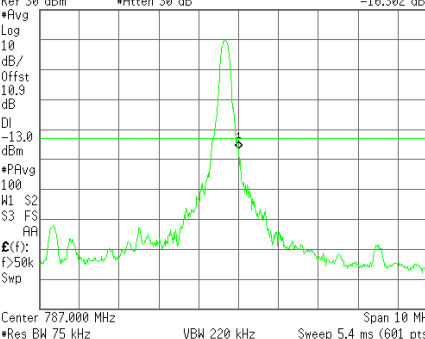
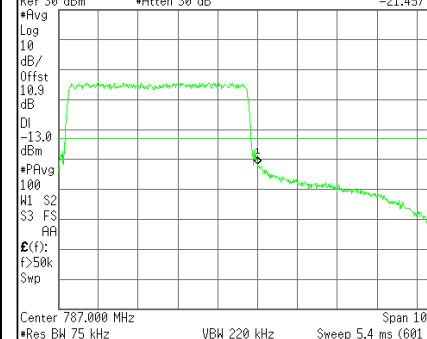
<p>Band LTE13 5MHz QPSK</p>	<p>Agilent 14:10:53 Oct 28, 2015 APv3.6(102315).JS, Conducted B Ref 30 dBm *Atten 30 dB Mkr1 777.000 MHz -19.501 dBm</p>  <p>Center 777.000 MHz *Res BW 75 kHz VBW 220 kHz Sweep 5.4 ms (601 pts)</p> <p>File Operation Status: C:PICTURE.GIF file saved</p> <p>Band LTE13 5MHz CBE QPSK Low Channel 1RB.gif</p>	<p>Freq/Channel Center Freq 777.000000 MHz Start Freq 772.000000 MHz Stop Freq 782.000000 MHz CF Step 1.00000000 MHz Auto Man Freq Offset 0.00000000 Hz Signal Track On Off</p>	<p>Agilent 14:11:17 Oct 28, 2015 APv3.6(102315).JS, Conducted B Ref 30 dBm *Atten 30 dB Mkr1 777.000 MHz -21.133 dBm</p>  <p>Center 777.000 MHz *Res BW 75 kHz VBW 220 kHz Sweep 5.4 ms (601 pts)</p> <p>File Operation Status: C:PICTURE.GIF file saved</p> <p>Band LTE13 5MHz CBE QPSK Low Channel FRB.gif</p>	<p>Freq/Channel Center Freq 777.000000 MHz Start Freq 772.000000 MHz Stop Freq 782.000000 MHz CF Step 1.00000000 MHz Auto Man Freq Offset 0.00000000 Hz Signal Track On Off</p>
<p>Band LTE13 5MHz QPSK</p>	<p>Agilent 14:12:10 Oct 28, 2015 APv3.6(102315).JS, Conducted B Ref 30 dBm *Atten 30 dB Mkr1 787.000 MHz -16.302 dBm</p>  <p>Center 787.000 MHz *Res BW 75 kHz VBW 220 kHz Sweep 5.4 ms (601 pts)</p> <p>File Operation Status: C:PICTURE.GIF file saved</p> <p>Band LTE13 5MHz CBE QPSK High Channel 1RB.gif</p>	<p>Freq/Channel Center Freq 787.000000 MHz Start Freq 782.000000 MHz Stop Freq 792.000000 MHz CF Step 1.00000000 MHz Auto Man Freq Offset 0.00000000 Hz Signal Track On Off</p>	<p>Agilent 14:12:28 Oct 28, 2015 APv3.6(102315).JS, Conducted B Ref 30 dBm *Atten 30 dB Mkr1 787.000 MHz -21.457 dBm</p>  <p>Center 787.000 MHz *Res BW 75 kHz VBW 220 kHz Sweep 5.4 ms (601 pts)</p> <p>File Operation Status: C:PICTURE.GIF file saved</p> <p>Band LTE13 5MHz CBE QPSK High Channel FRB.gif</p>	<p>Freq/Channel Center Freq 787.000000 MHz Start Freq 782.000000 MHz Stop Freq 792.000000 MHz CF Step 1.00000000 MHz Auto Man Freq Offset 0.00000000 Hz Signal Track On Off</p>

LTE17

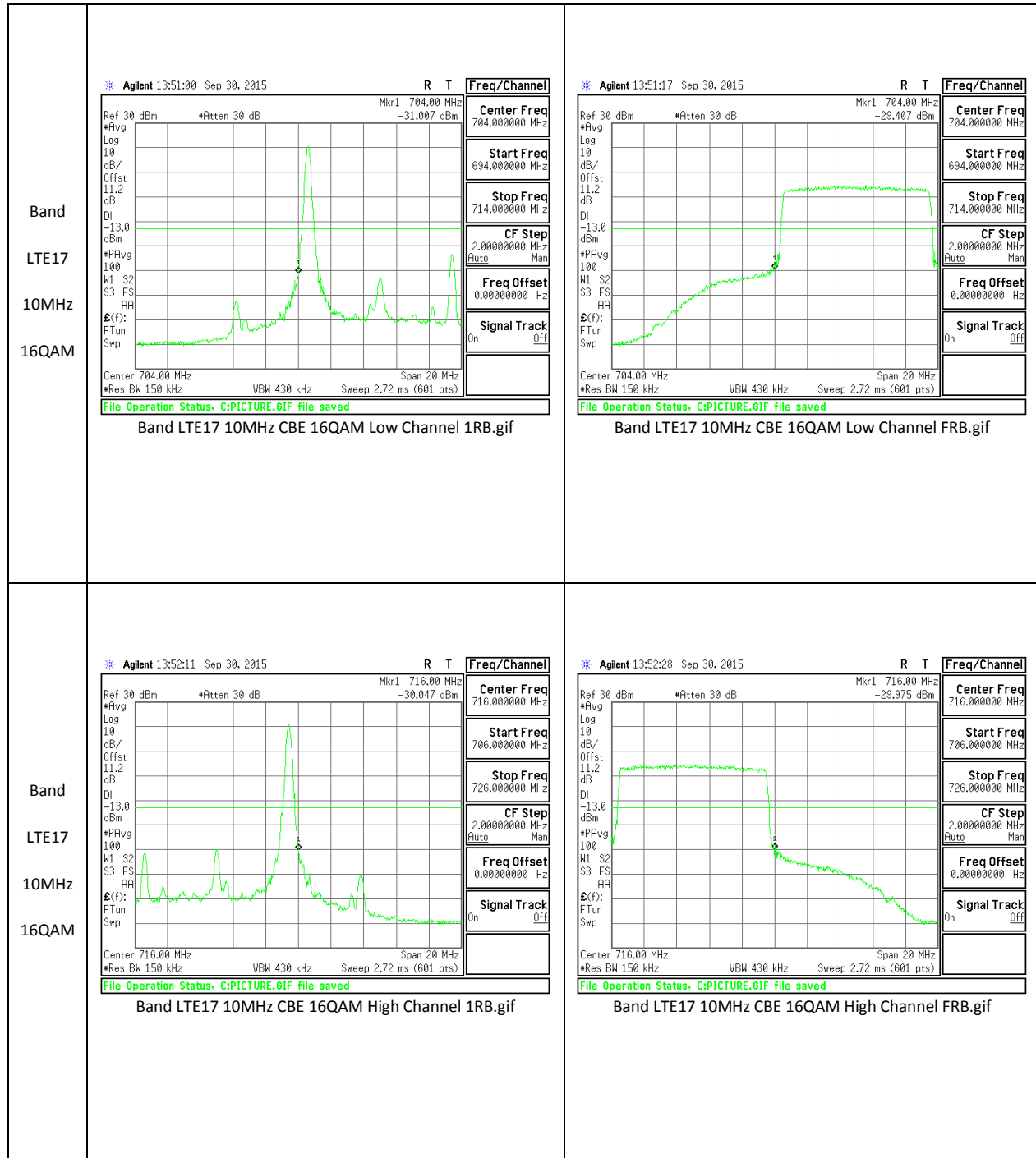

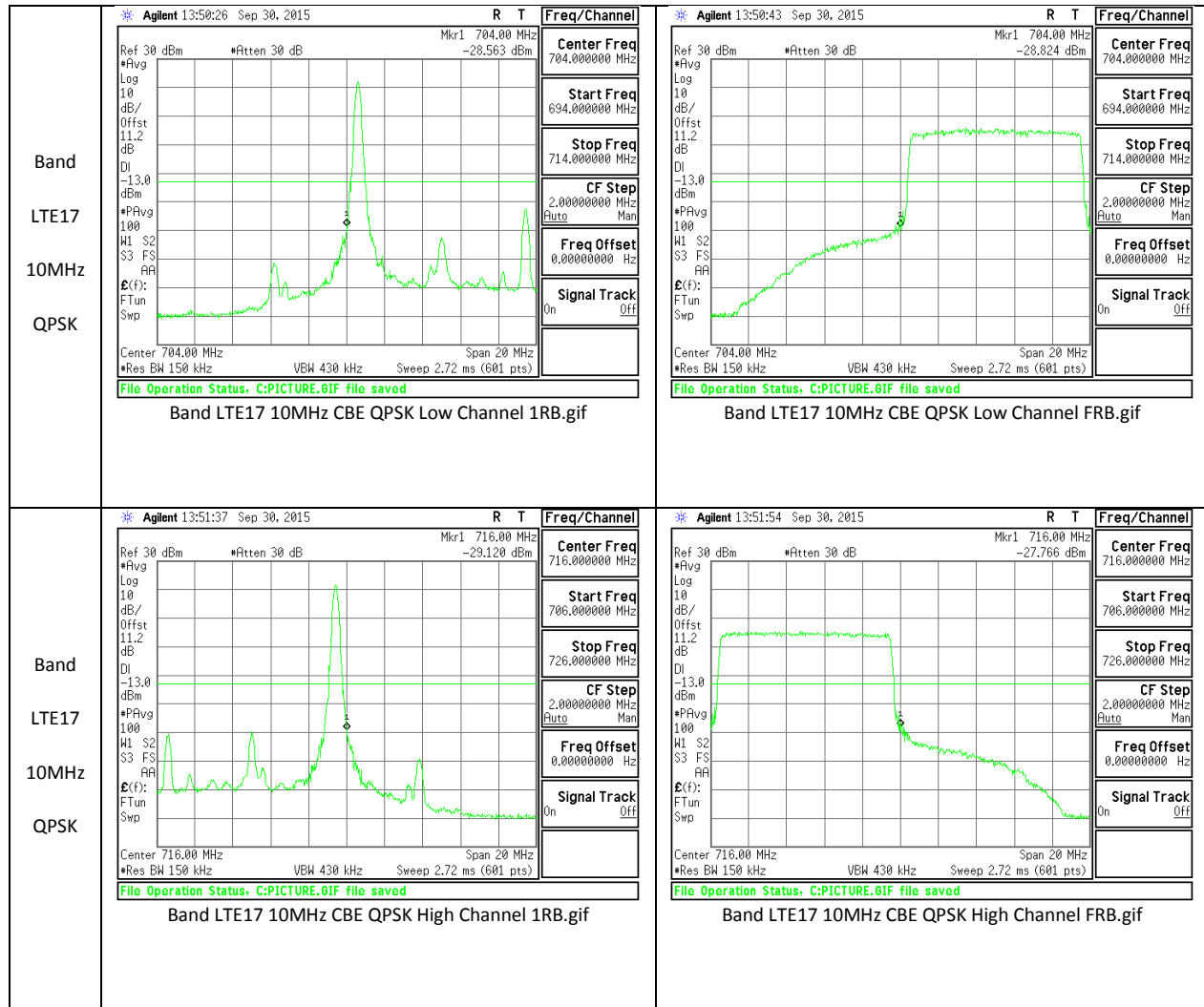

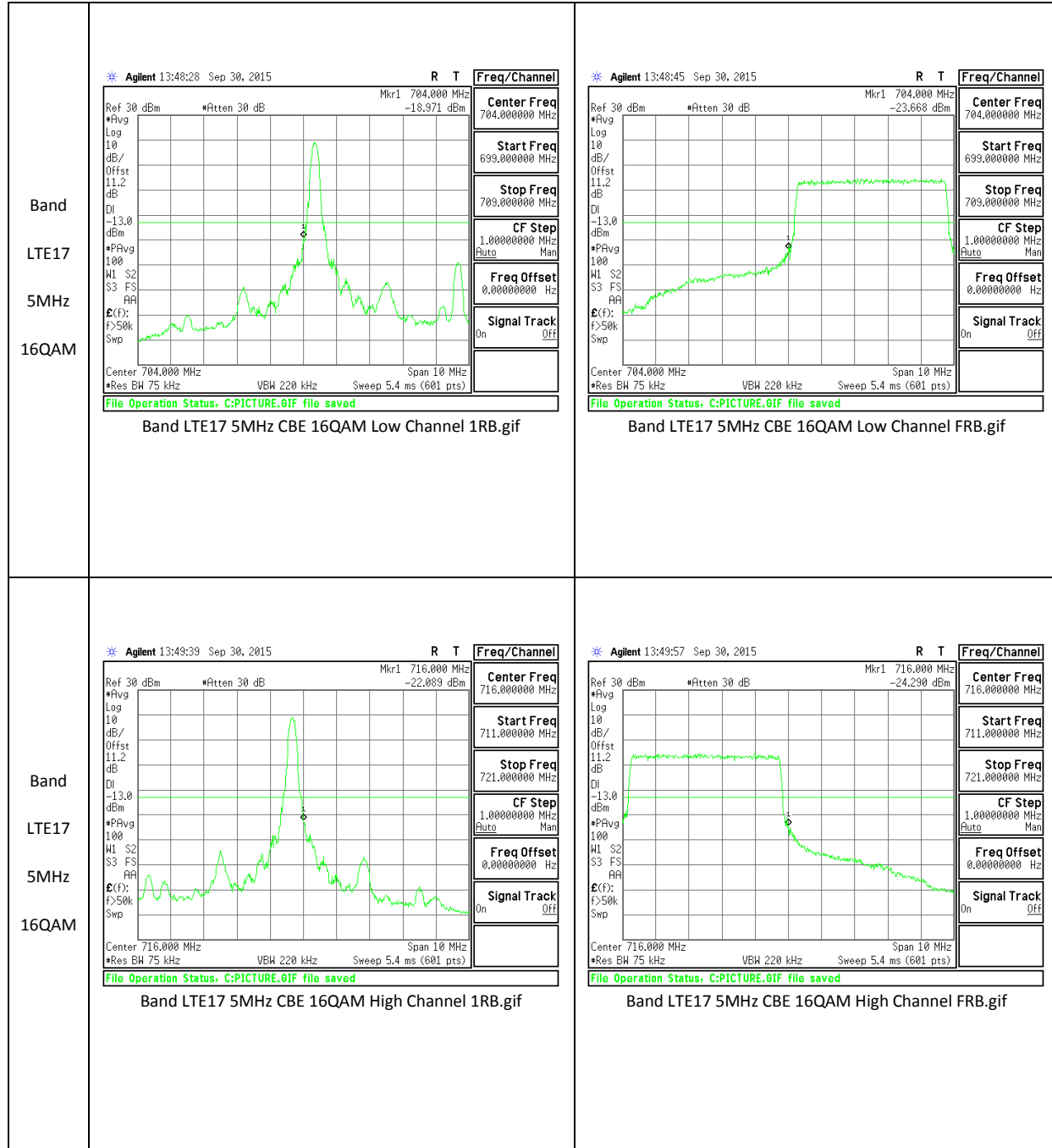

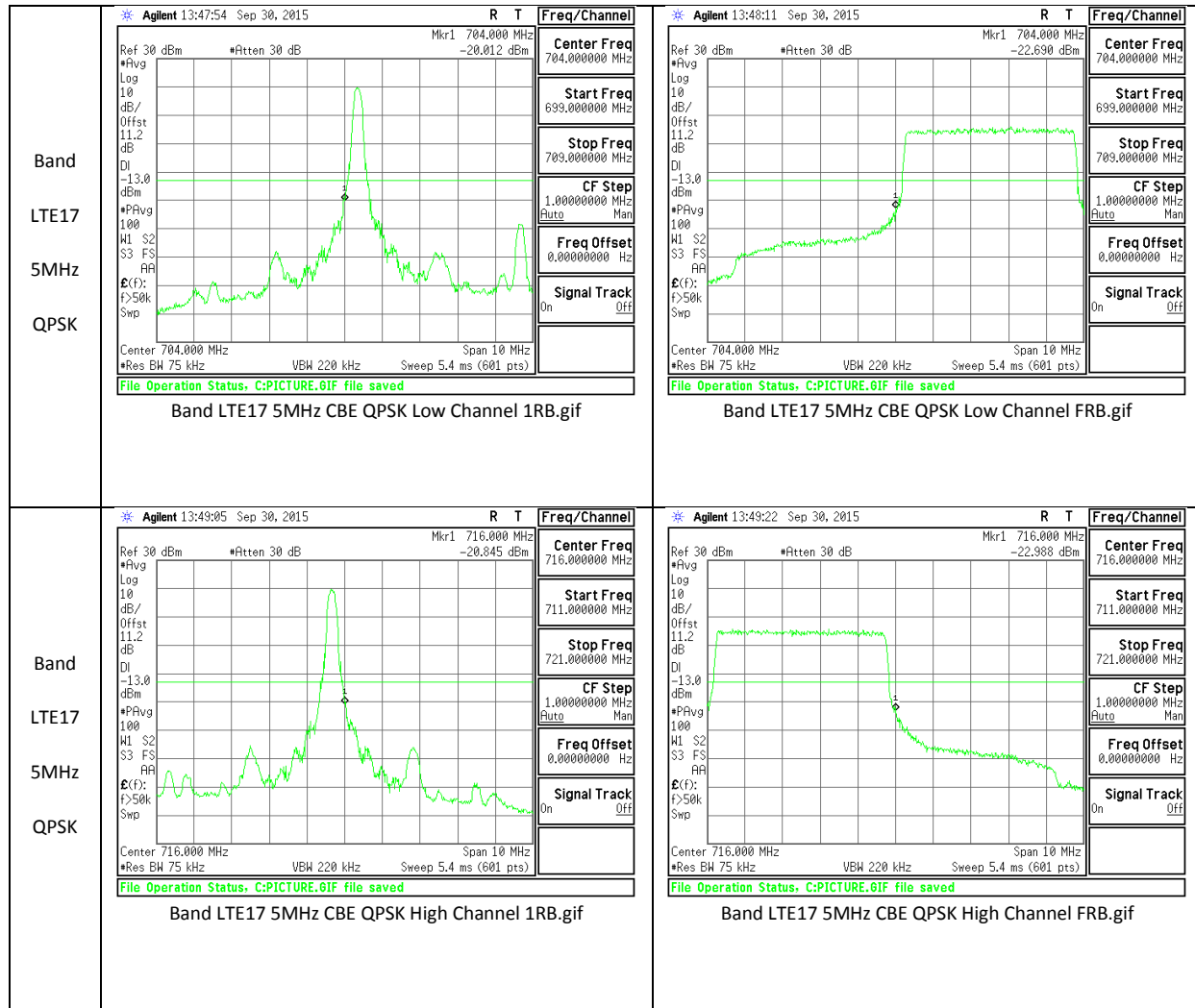

LTE Band 26

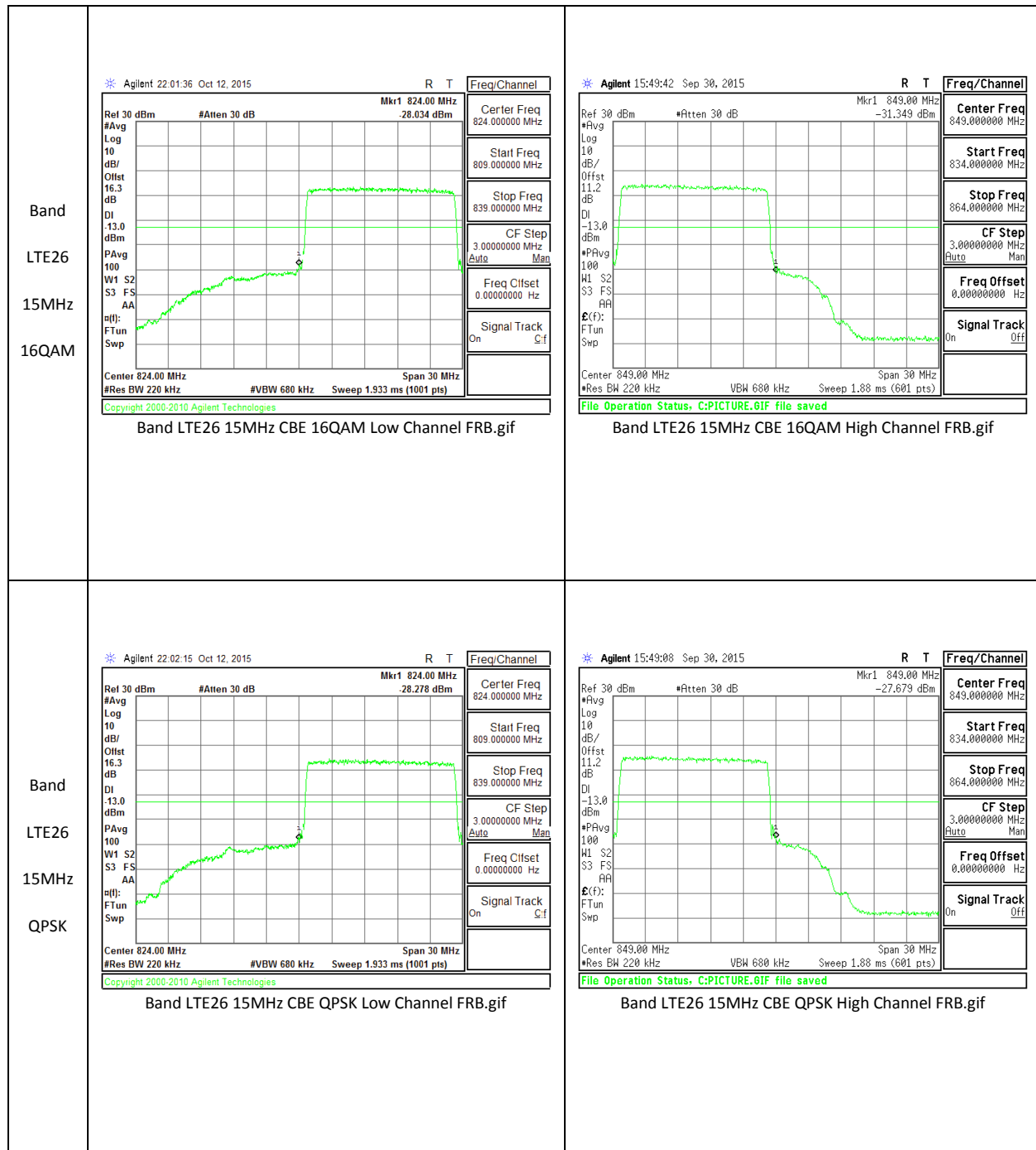

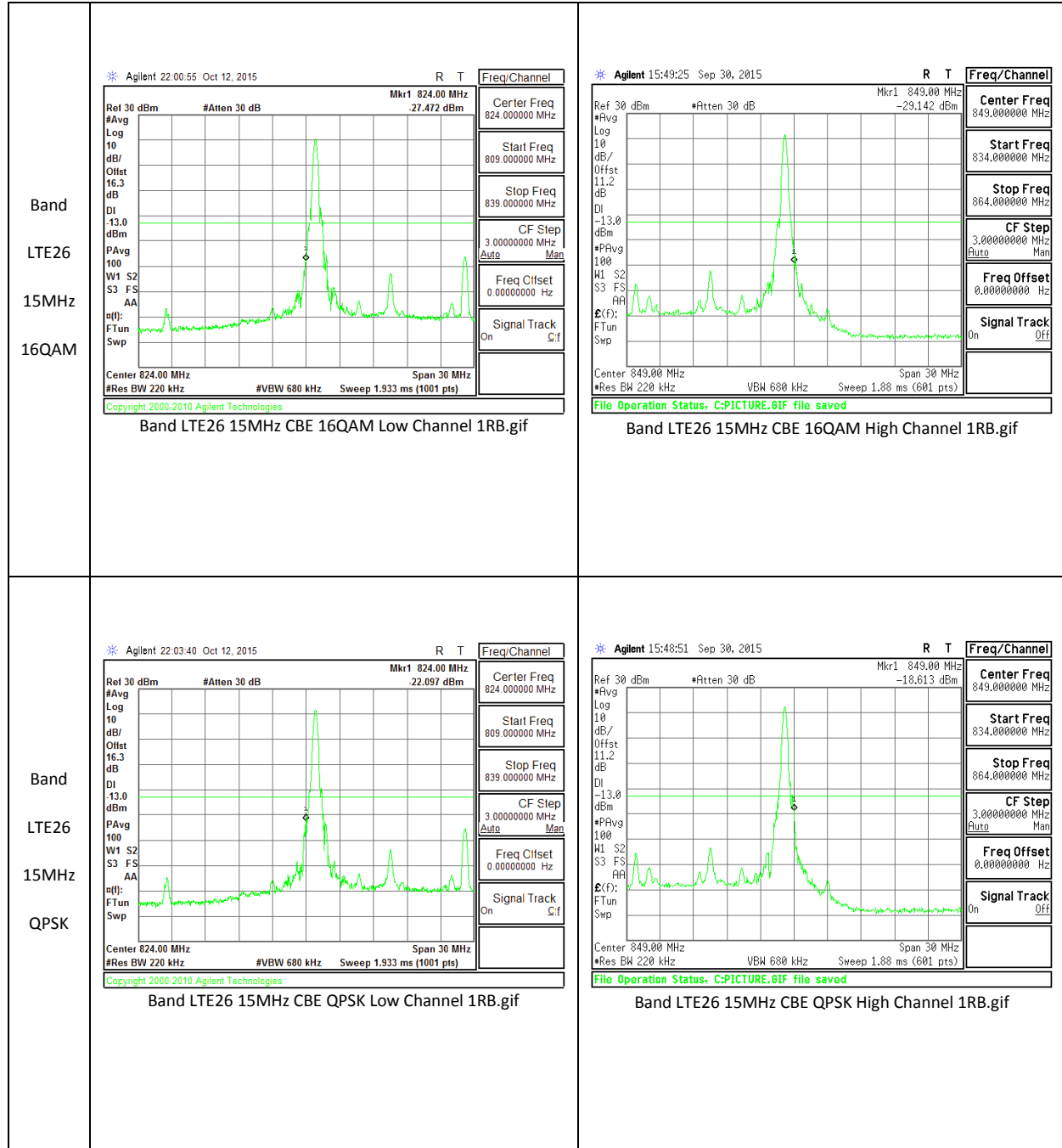

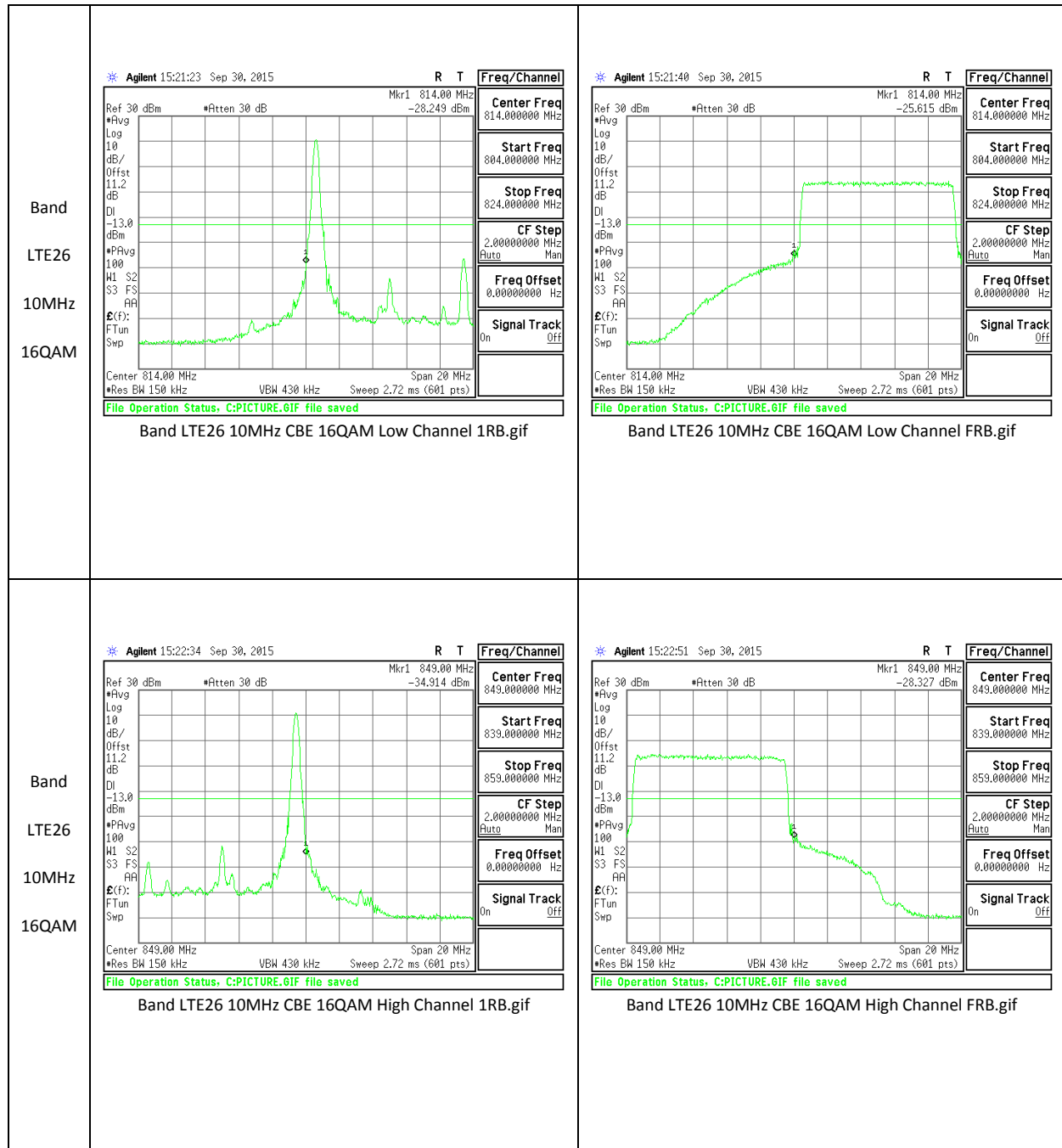

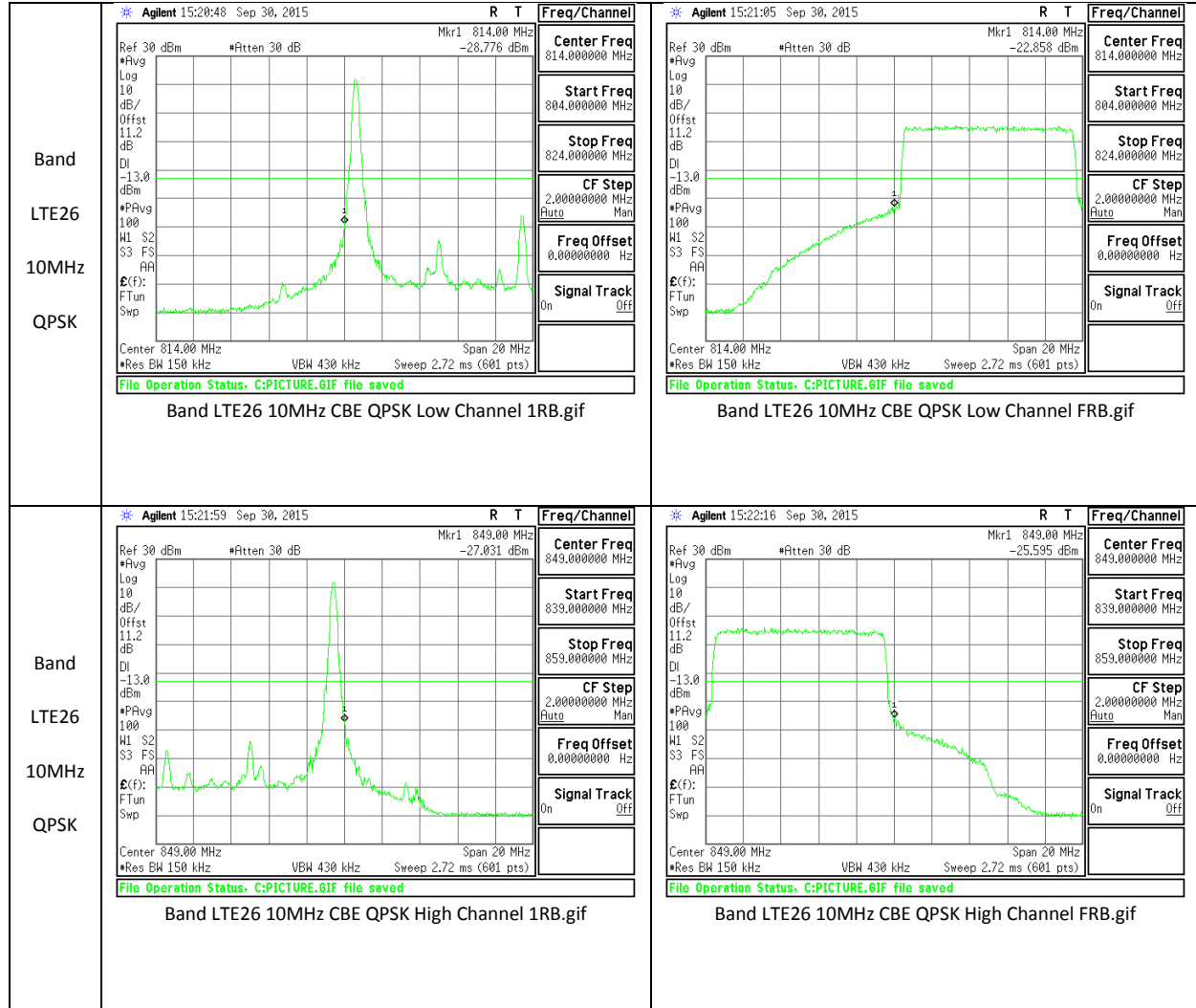

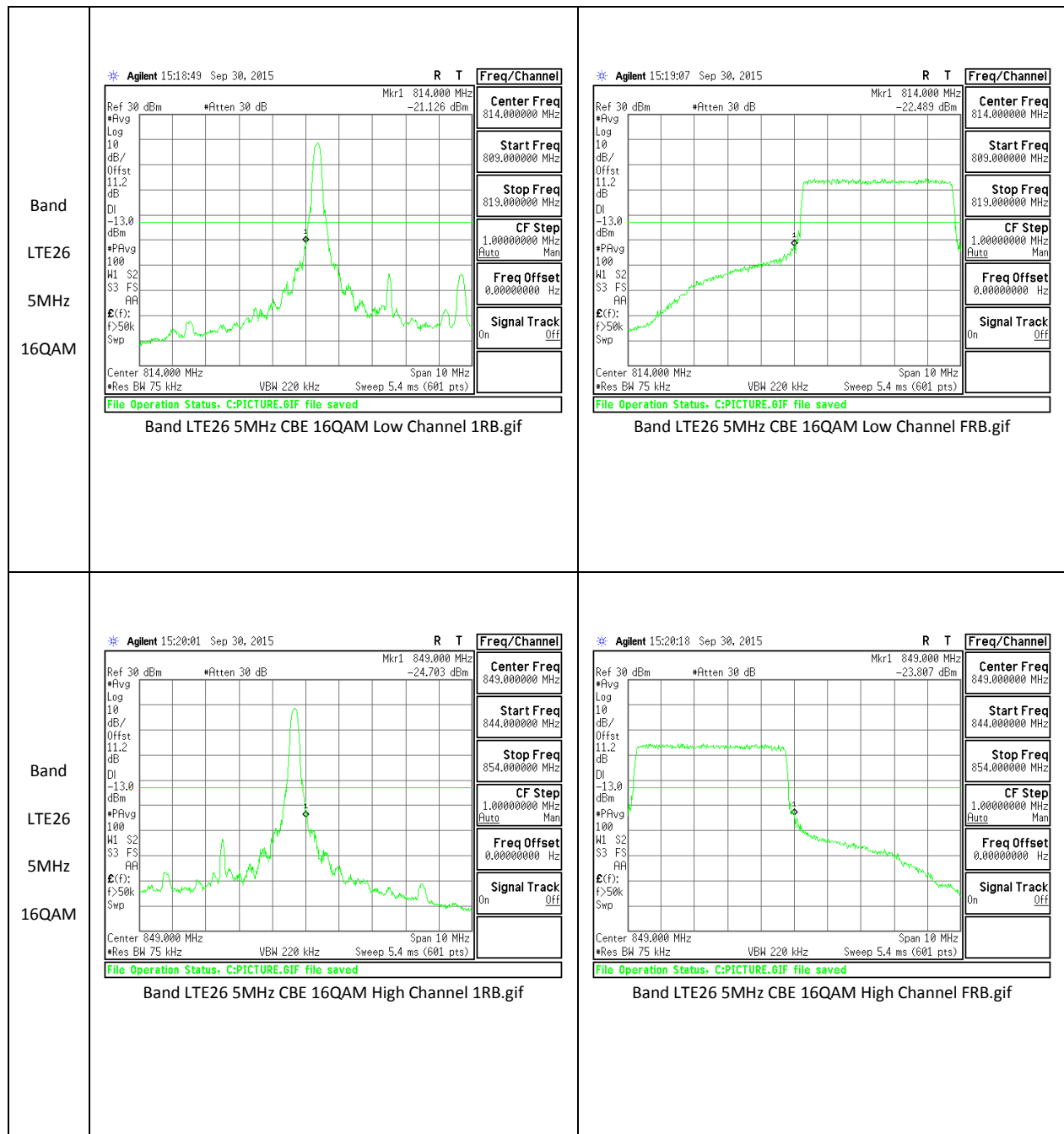

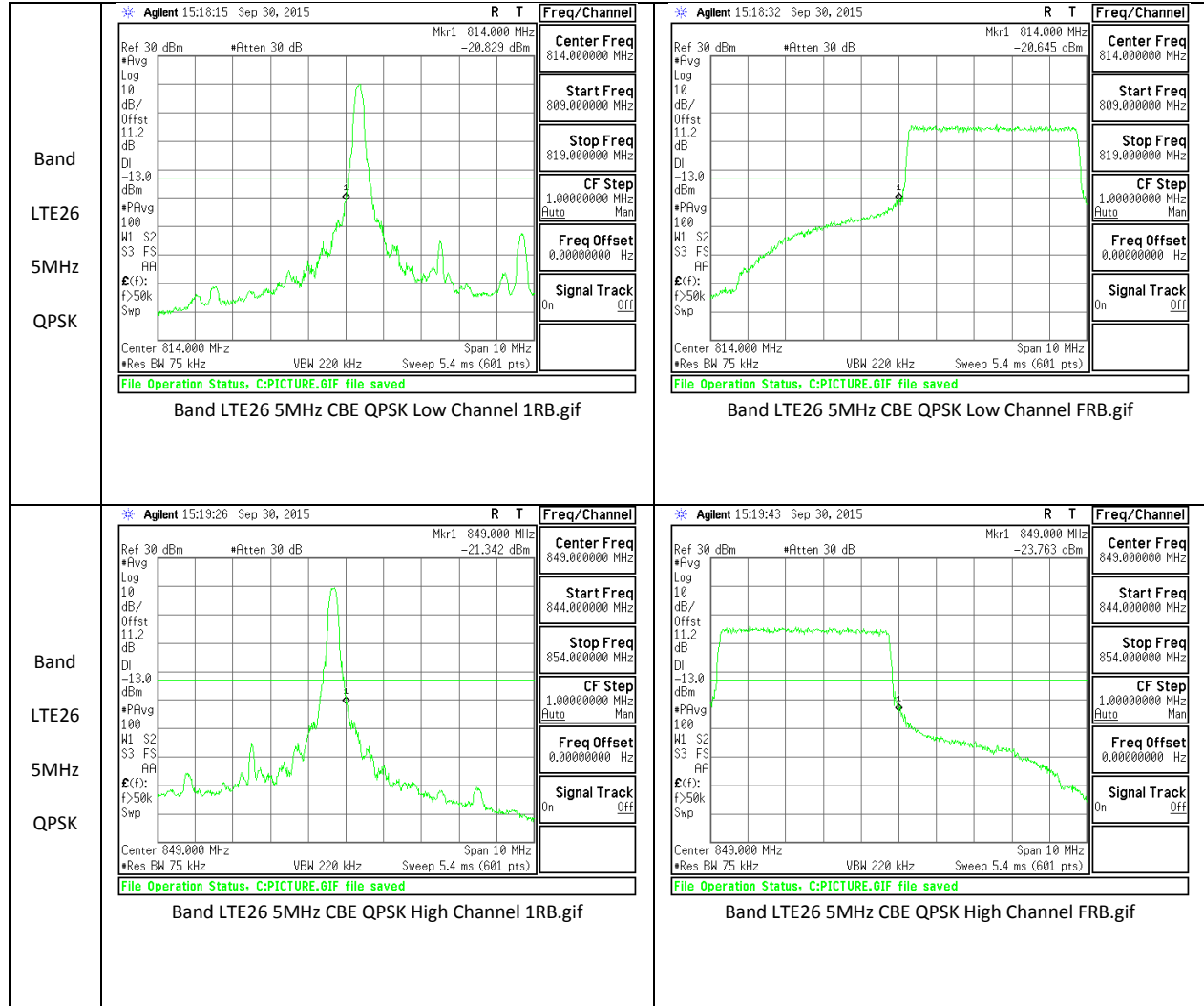

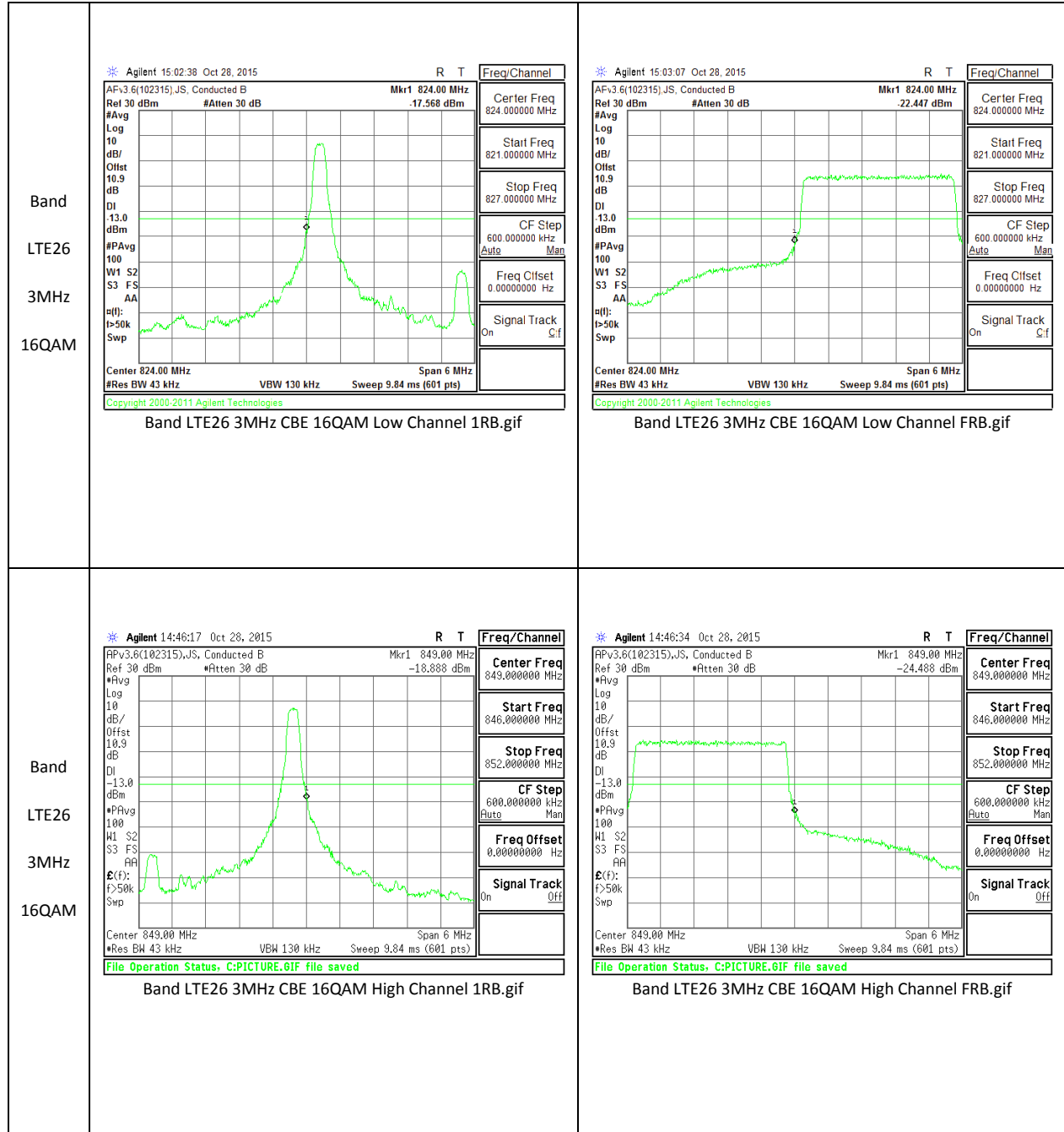

<p>Band LTE26 3MHz QPSK</p>	<p>Agilent 15:02:05 Oct 28, 2015 R T AFv3.6(102315),JS, Conducted B Mkr1 824.00 MHz Rel 30 dBm #Atten 30 dB -17.230 dBm #Avg Log 10 dB/ Offst 10.9 dB DI -13.0 dBm #PAvg 100 W1 S2 S3 FS AA #f(): f>50k Swp Center 824.00 MHz Span 6 MHz #Res BW 43 kHz VBW 130 kHz Sweep 9.84 ms (601 pts) Copyright 2000-2011 Agilent Technologies</p> <p>Freq/Channel Center Freq 824.000000 MHz Start Freq 821.000000 MHz Stop Freq 827.000000 MHz CF Step 600.000000 kHz Auto Man Freq Offset 0.00000000 Hz Signal Track On Cf</p> <p>Band LTE26 3MHz CBE QPSK Low Channel 1RB.gif</p>	<p>Agilent 15:01:13 Oct 28, 2015 R T AFv3.6(102315),JS, Conducted B Mkr1 824.00 MHz Rel 30 dBm #Atten 30 dB -21.518 dBm #Avg Log 10 dB/ Offst 10.9 dB DI -13.0 dBm #PAvg 100 W1 S2 S3 FS AA #f(): f>50k Swp Center 824.00 MHz Span 6 MHz #Res BW 43 kHz VBW 130 kHz Sweep 9.84 ms (601 pts) Copyright 2000-2011 Agilent Technologies</p> <p>Freq/Channel Center Freq 824.000000 MHz Start Freq 821.000000 MHz Stop Freq 827.000000 MHz CF Step 600.000000 kHz Auto Man Freq Offset 0.00000000 Hz Signal Track On Cf</p> <p>Band LTE26 3MHz CBE QPSK Low Channel FRB.gif</p>
<p>Band LTE26 3MHz QPSK</p>	<p>Agilent 14:45:43 Oct 28, 2015 R T APv3.6(102315),JS, Conducted B Mkr1 849.00 MHz Ref 30 dBm #Atten 30 dB -17.073 dBm #Avg Log 10 dB/ Offst 10.9 dB DI -13.0 dBm #PAvg 100 W1 S2 S3 FS AA #f(): f>50k Swp Center 849.00 MHz Span 6 MHz #Res BW 43 kHz VBW 130 kHz Sweep 9.84 ms (601 pts) File Operation Status, C:PICTURE.GIF file saved</p> <p>Freq/Channel Center Freq 849.000000 MHz Start Freq 846.000000 MHz Stop Freq 852.000000 MHz CF Step 600.000000 kHz Auto Man Freq Offset 0.00000000 Hz Signal Track On Off</p> <p>Band LTE26 3MHz CBE QPSK High Channel 1RB.gif</p>	<p>Agilent 14:46:00 Oct 28, 2015 R T APv3.6(102315),JS, Conducted B Mkr1 849.00 MHz Ref 30 dBm #Atten 30 dB -23.918 dBm #Avg Log 10 dB/ Offst 10.9 dB DI -13.0 dBm #PAvg 100 W1 S2 S3 FS AA #f(): f>50k Swp Center 849.00 MHz Span 6 MHz #Res BW 43 kHz VBW 130 kHz Sweep 9.84 ms (601 pts) File Operation Status, C:PICTURE.GIF file saved</p> <p>Freq/Channel Center Freq 849.000000 MHz Start Freq 846.000000 MHz Stop Freq 852.000000 MHz CF Step 600.000000 kHz Auto Man Freq Offset 0.00000000 Hz Signal Track On Off</p> <p>Band LTE26 3MHz CBE QPSK High Channel FRB.gif</p>

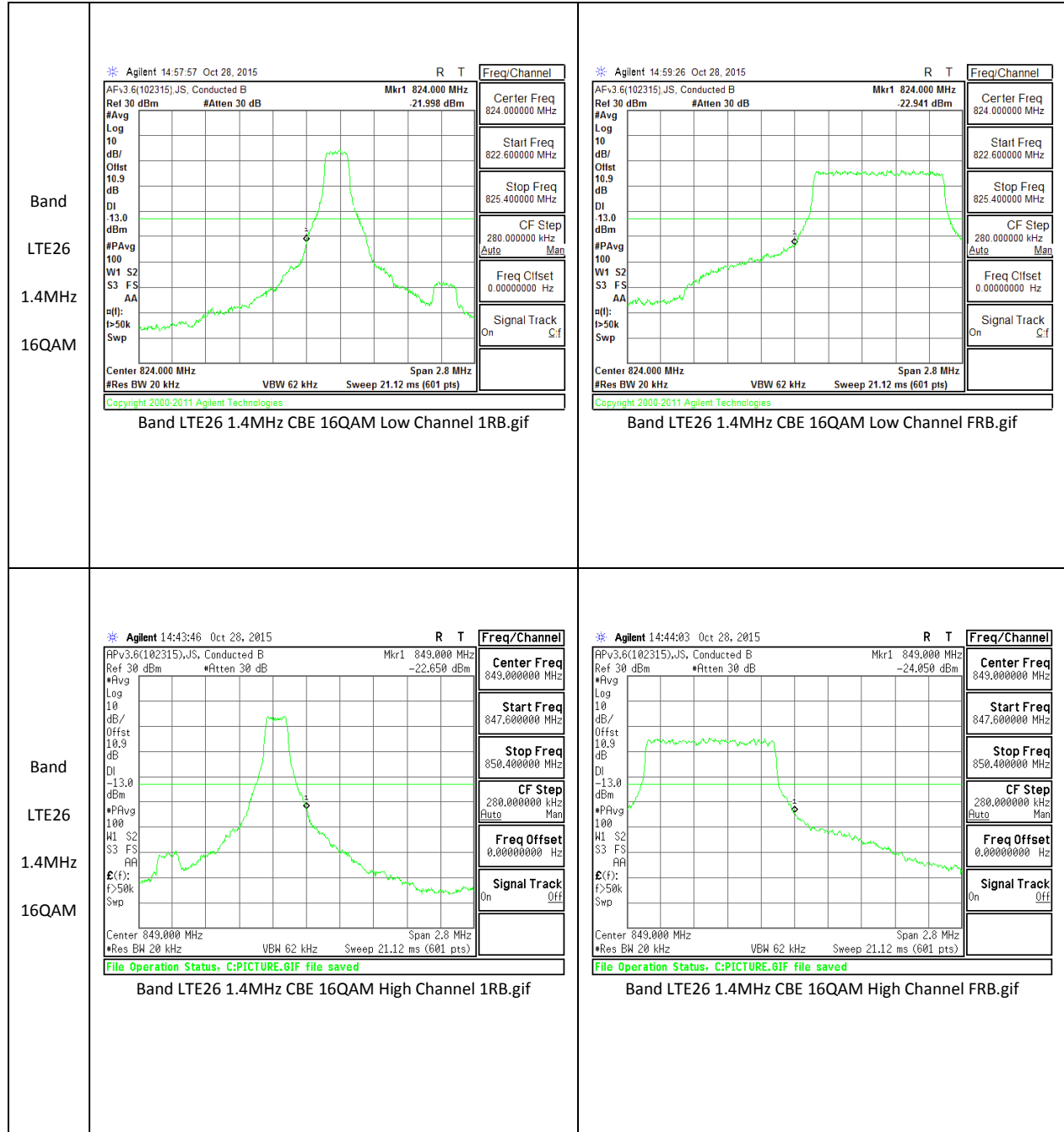

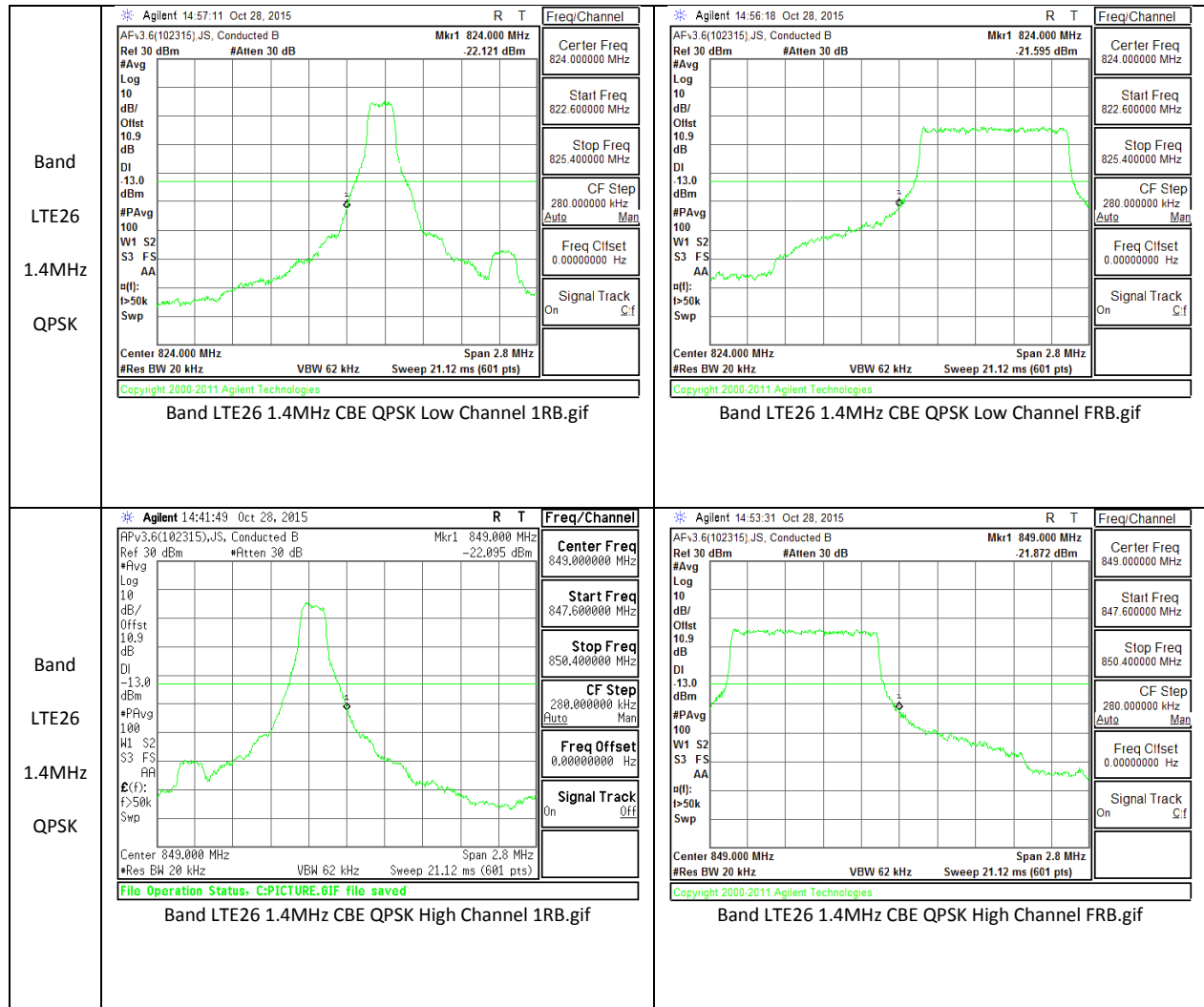

LTE Band 41

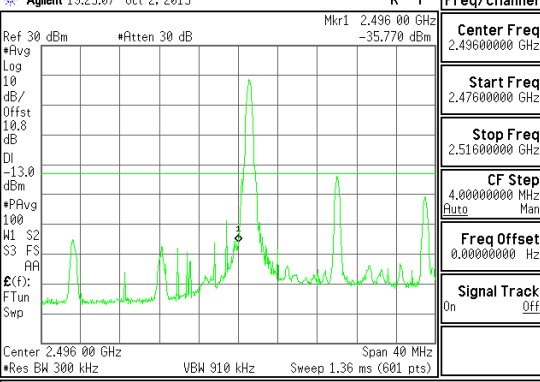
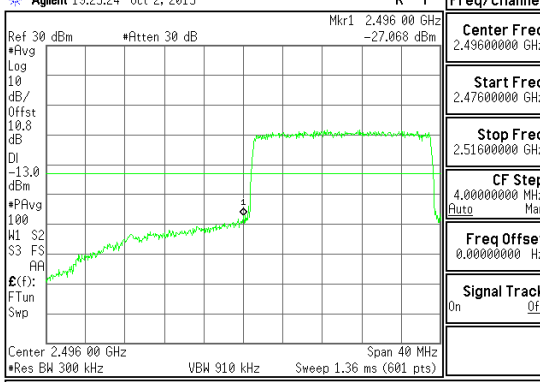
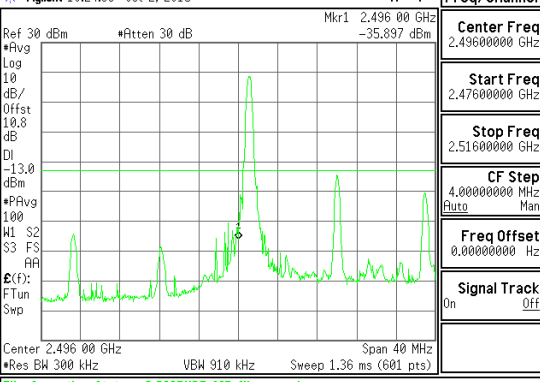
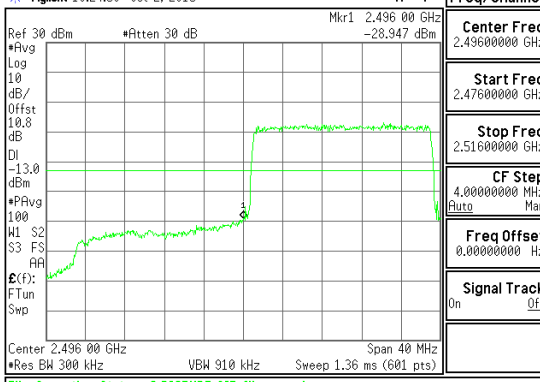
<p>Band LTE41 20MHz 16QAM</p>	 <p>Agilent 19:25:07 Oct 2, 2015 R T</p> <p>Ref 30 dBm *Atten 30 dB Mkr1 2.496 00 GHz -35.770 dBm</p> <p>Center Freq 2.49600000 GHz</p> <p>Start Freq 2.47600000 GHz</p> <p>Stop Freq 2.51600000 GHz</p> <p>CF Step 4.00000000 MHz Auto Man</p> <p>Freq Offset 0.00000000 Hz</p> <p>Signal Track On Off</p> <p>Center 2.496 00 GHz Span 40 MHz *Res BW 300 kHz VBW 910 kHz Sweep 1.36 ms (601 pts)</p> <p>File Operation Status: C:PICTURE.GIF file saved</p> <p>Band LTE41 20MHz CBE 16QAM Low Channel 1RB.gif</p>	 <p>Agilent 19:25:24 Oct 2, 2015 R T</p> <p>Ref 30 dBm *Atten 30 dB Mkr1 2.496 00 GHz -27.068 dBm</p> <p>Center Freq 2.49600000 GHz</p> <p>Start Freq 2.47600000 GHz</p> <p>Stop Freq 2.51600000 GHz</p> <p>CF Step 4.00000000 MHz Auto Man</p> <p>Freq Offset 0.00000000 Hz</p> <p>Signal Track On Off</p> <p>Center 2.496 00 GHz Span 40 MHz *Res BW 300 kHz VBW 910 kHz Sweep 1.36 ms (601 pts)</p> <p>File Operation Status: C:PICTURE.GIF file saved</p> <p>Band LTE41 20MHz CBE 16QAM Low Channel FRB.gif</p>
<p>Band LTE41 20MHz QPSK</p>	 <p>Agilent 19:24:33 Oct 2, 2015 R T</p> <p>Ref 30 dBm *Atten 30 dB Mkr1 2.496 00 GHz -35.897 dBm</p> <p>Center Freq 2.49600000 GHz</p> <p>Start Freq 2.47600000 GHz</p> <p>Stop Freq 2.51600000 GHz</p> <p>CF Step 4.00000000 MHz Auto Man</p> <p>Freq Offset 0.00000000 Hz</p> <p>Signal Track On Off</p> <p>Center 2.496 00 GHz Span 40 MHz *Res BW 300 kHz VBW 910 kHz Sweep 1.36 ms (601 pts)</p> <p>File Operation Status: C:PICTURE.GIF file saved</p> <p>Band LTE41 20MHz CBE QPSK Low Channel 1RB.gif</p>	 <p>Agilent 19:24:50 Oct 2, 2015 R T</p> <p>Ref 30 dBm *Atten 30 dB Mkr1 2.496 00 GHz -28.947 dBm</p> <p>Center Freq 2.49600000 GHz</p> <p>Start Freq 2.47600000 GHz</p> <p>Stop Freq 2.51600000 GHz</p> <p>CF Step 4.00000000 MHz Auto Man</p> <p>Freq Offset 0.00000000 Hz</p> <p>Signal Track On Off</p> <p>Center 2.496 00 GHz Span 40 MHz *Res BW 300 kHz VBW 910 kHz Sweep 1.36 ms (601 pts)</p> <p>File Operation Status: C:PICTURE.GIF file saved</p> <p>Band LTE41 20MHz CBE QPSK Low Channel FRB.gif</p>

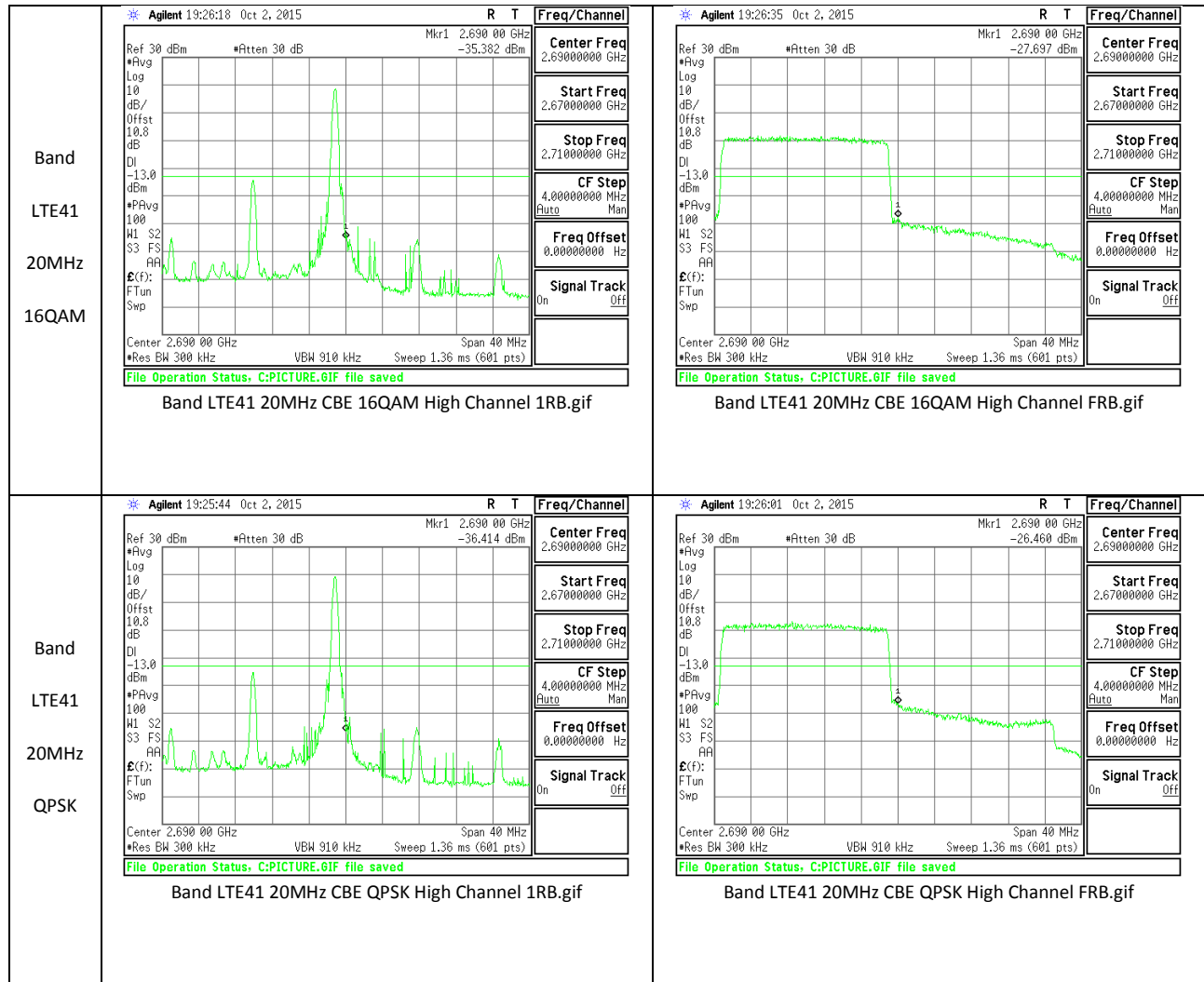

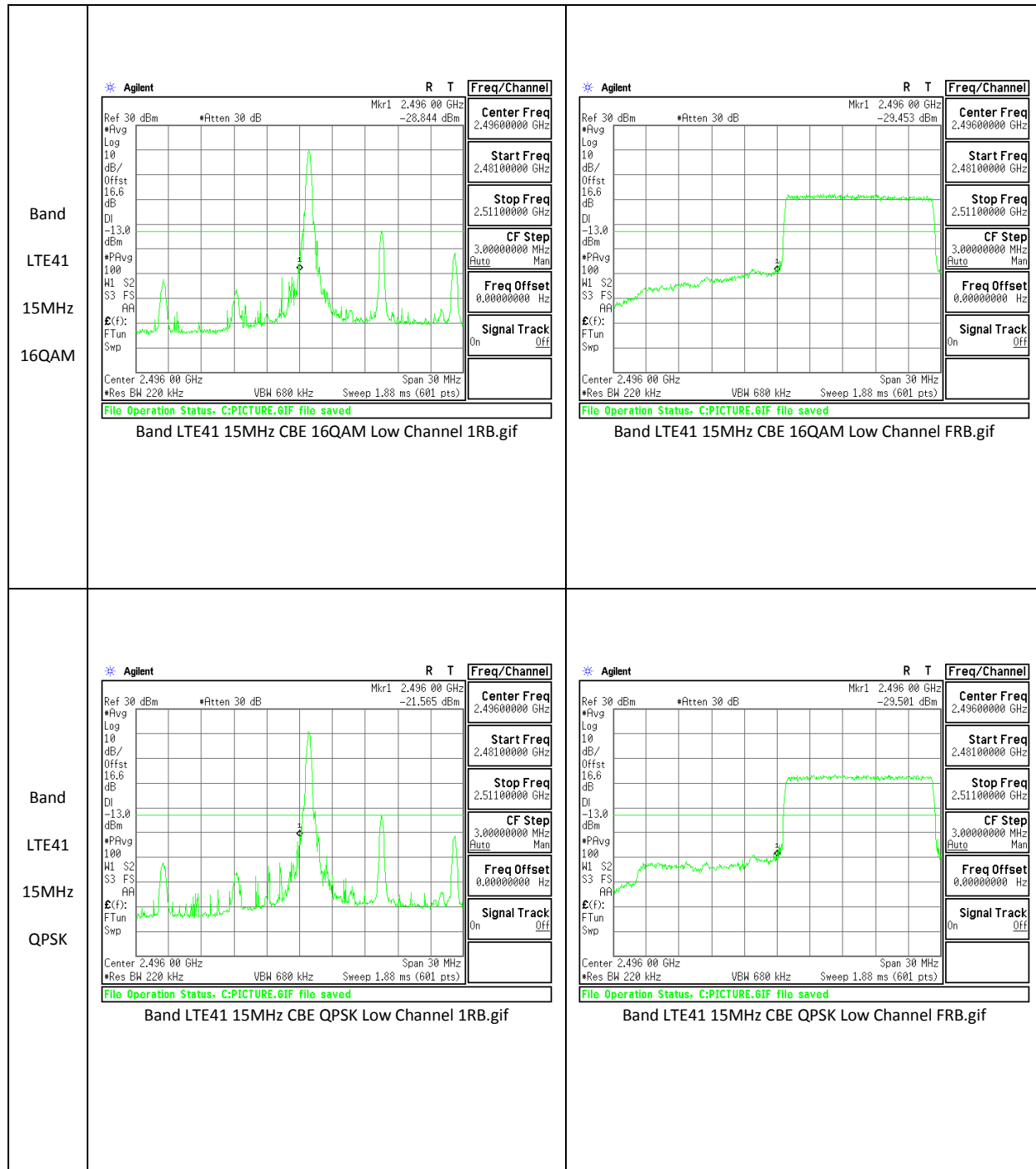

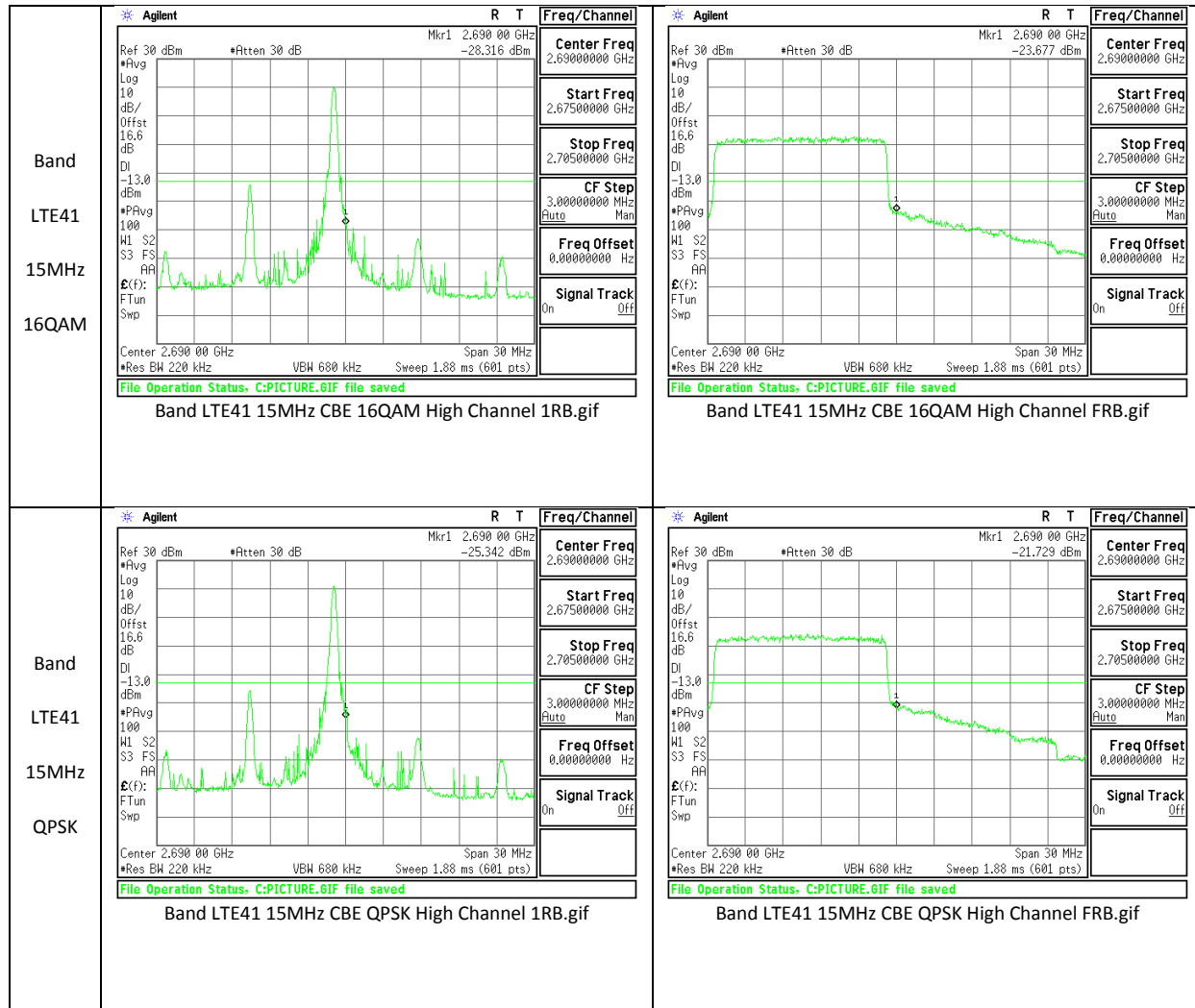

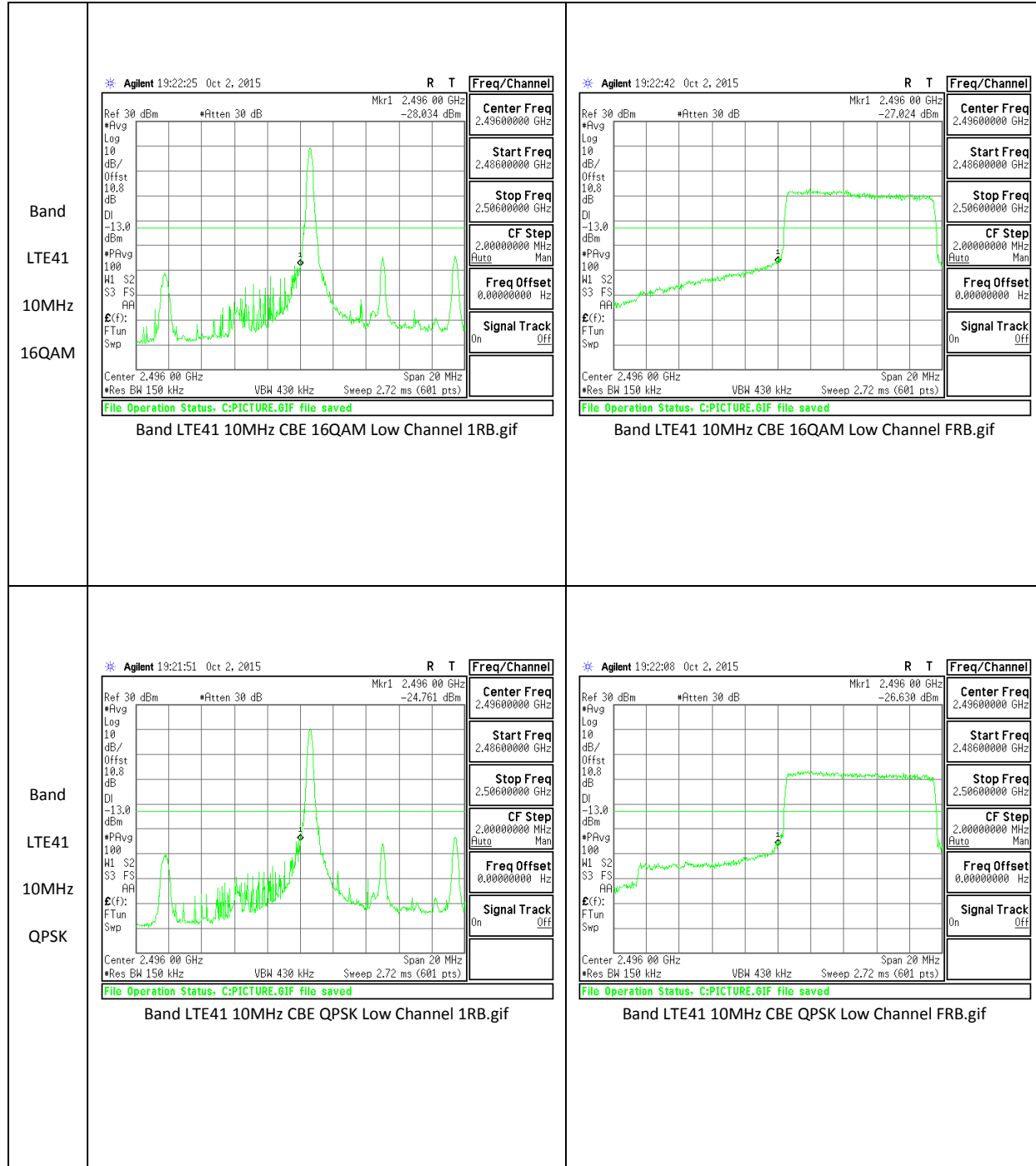

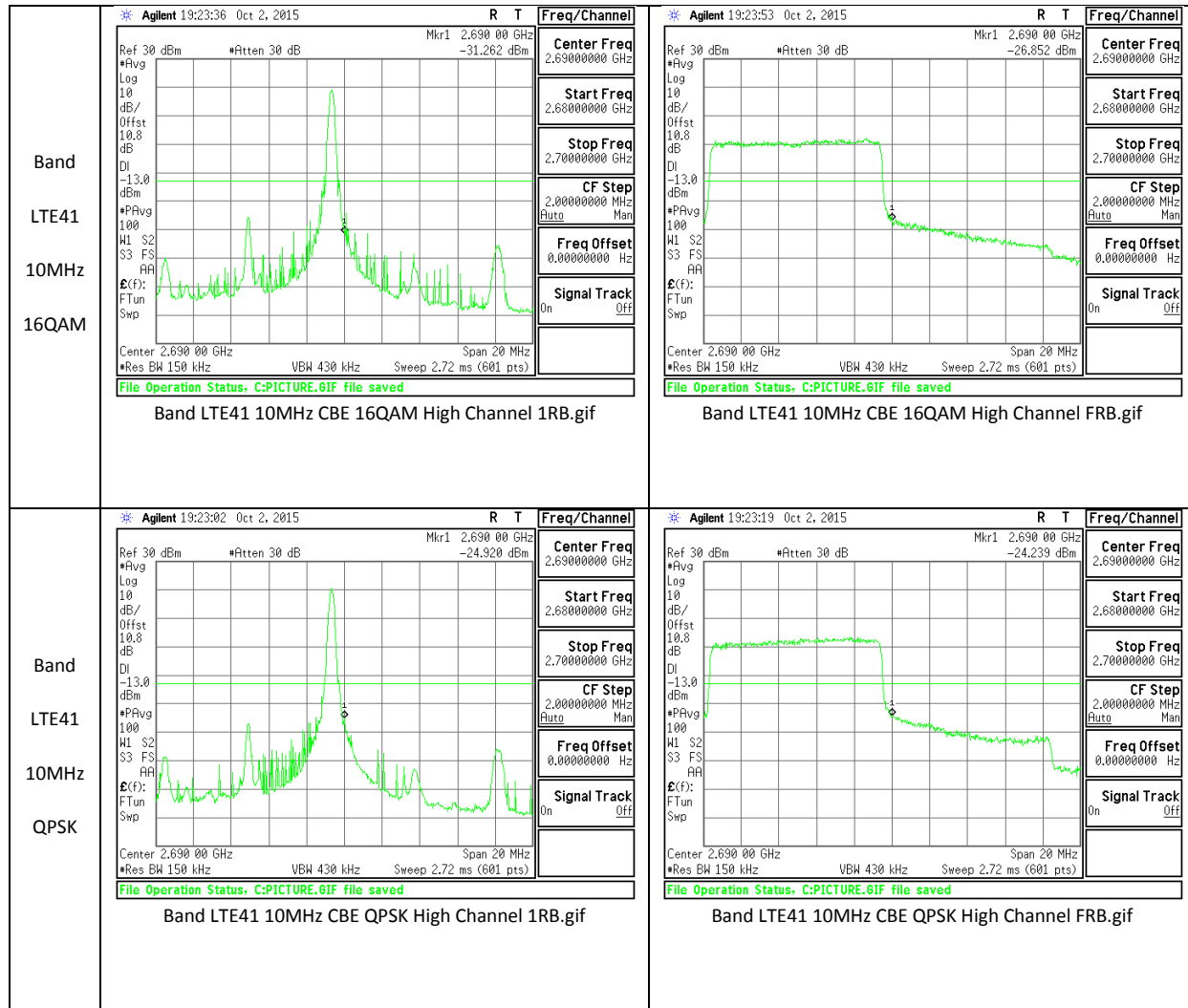

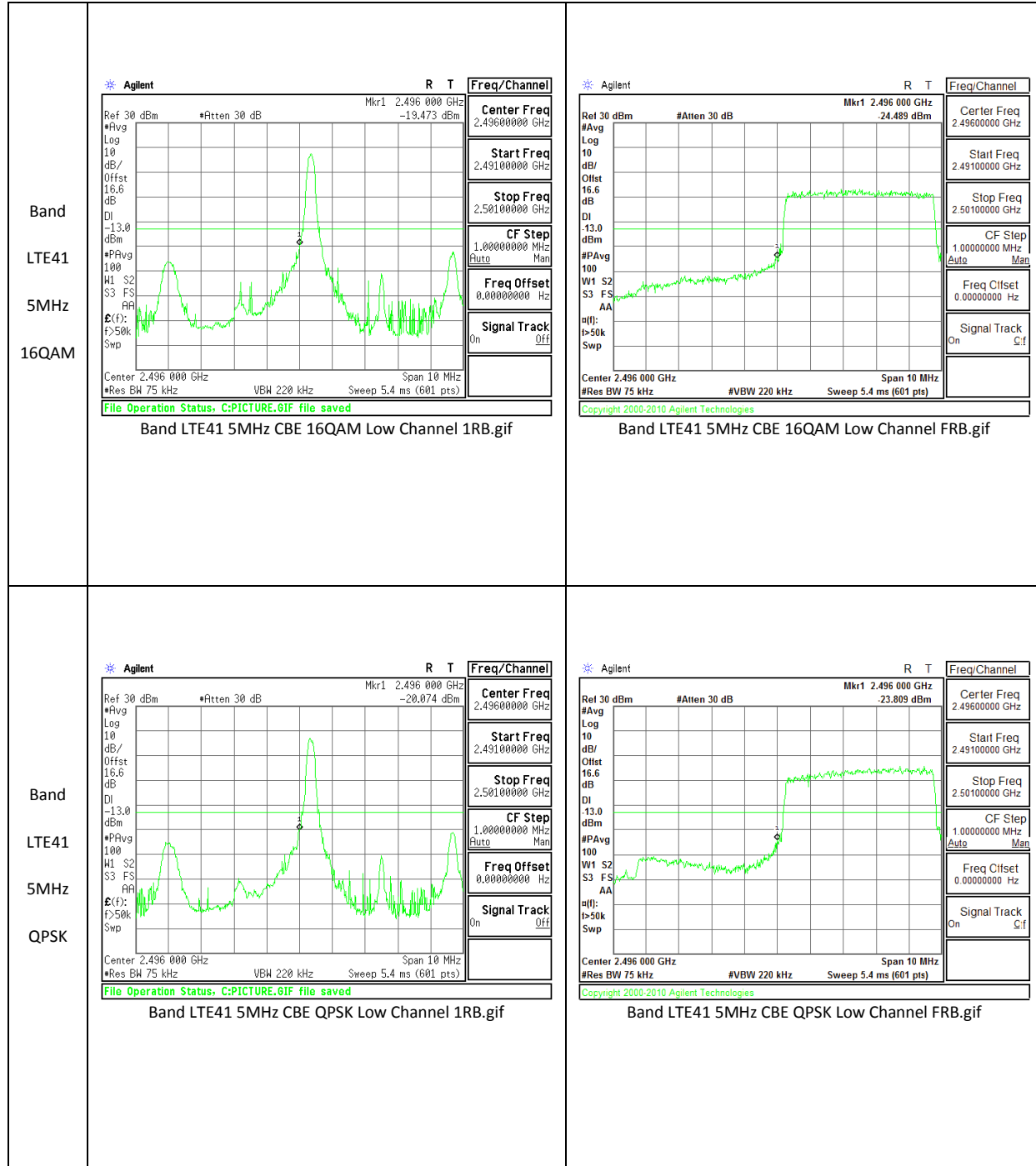

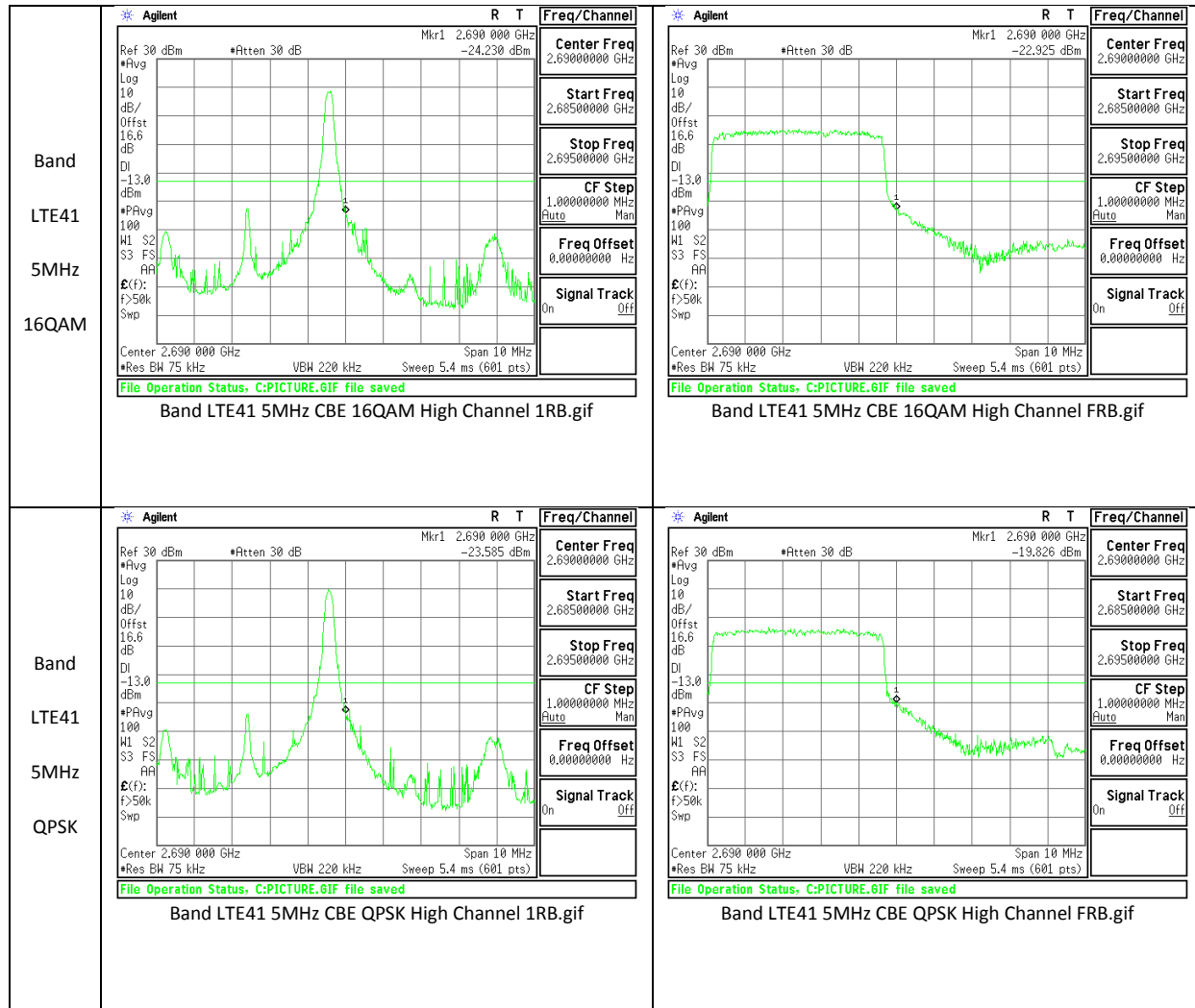

10.2.2. EMISSION MASK PLOTS

LTE Band 26

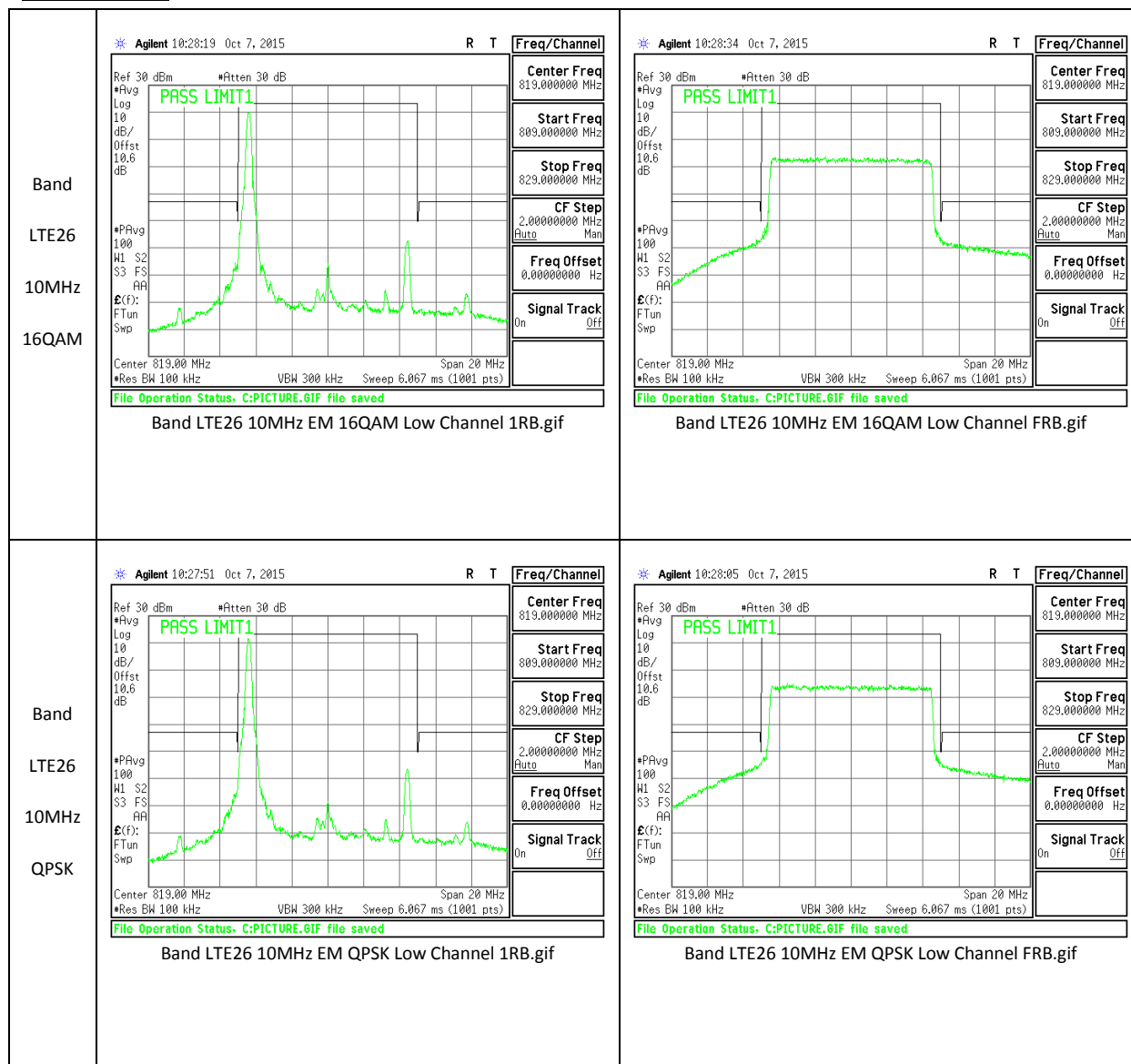

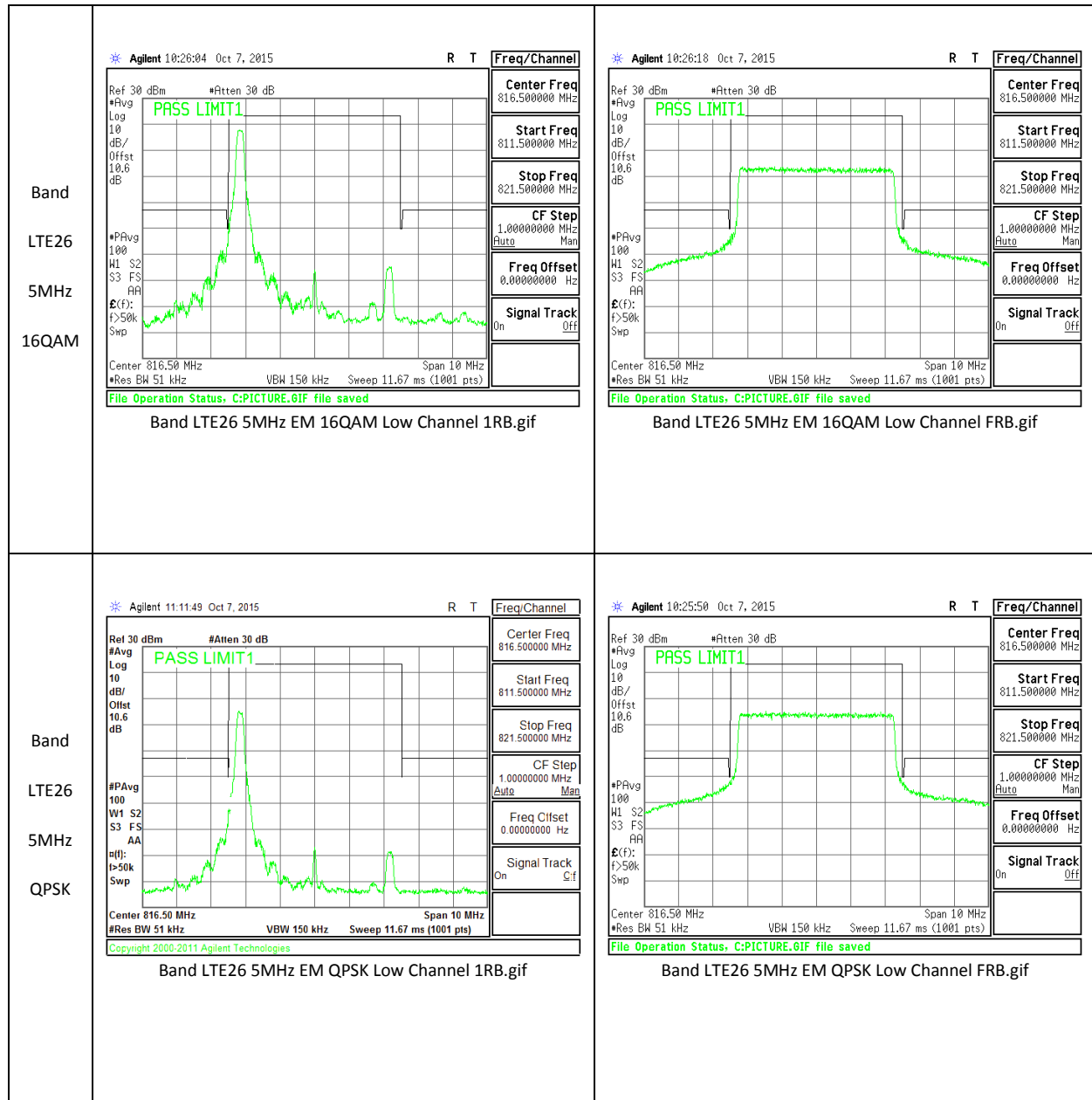

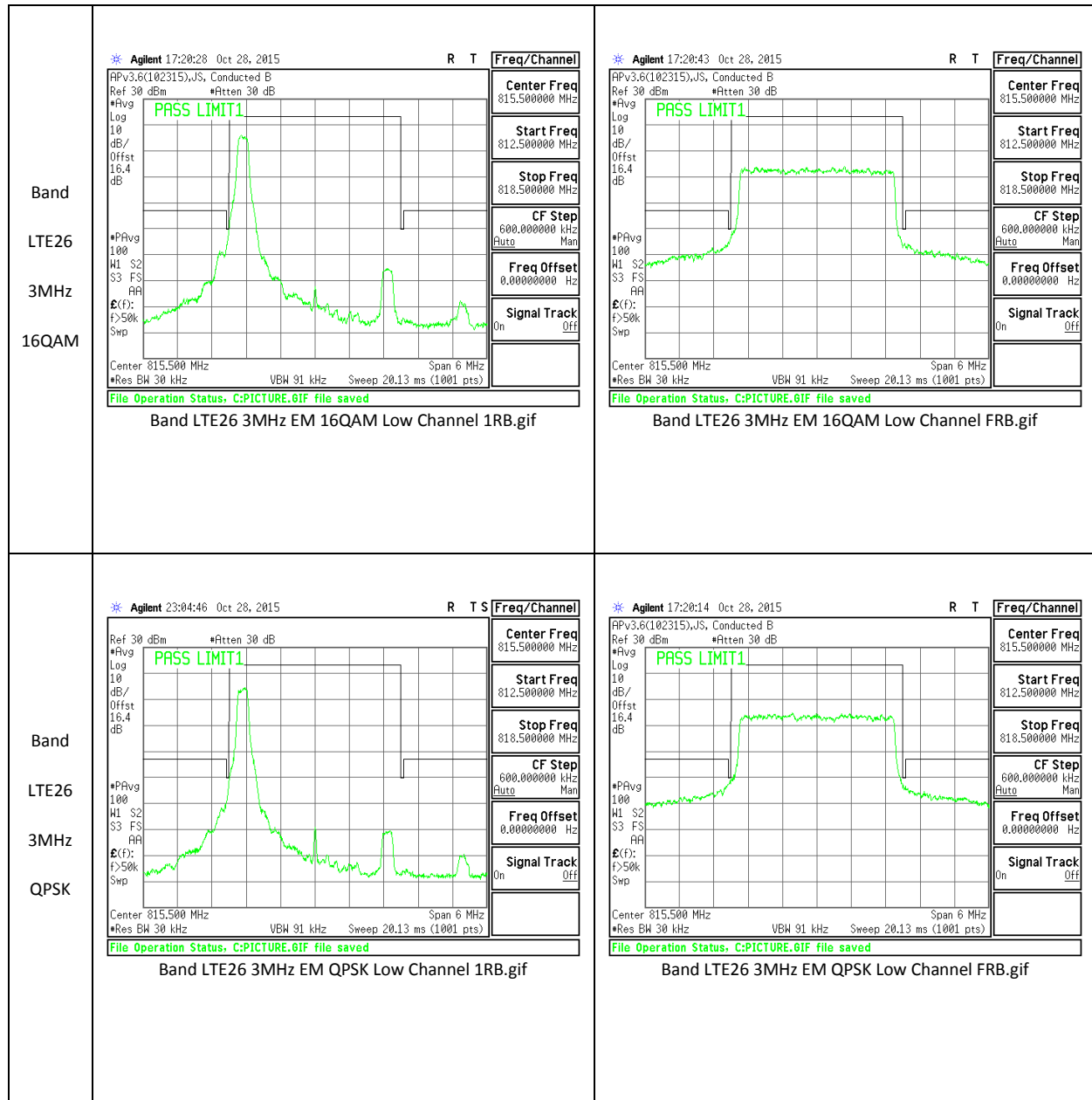

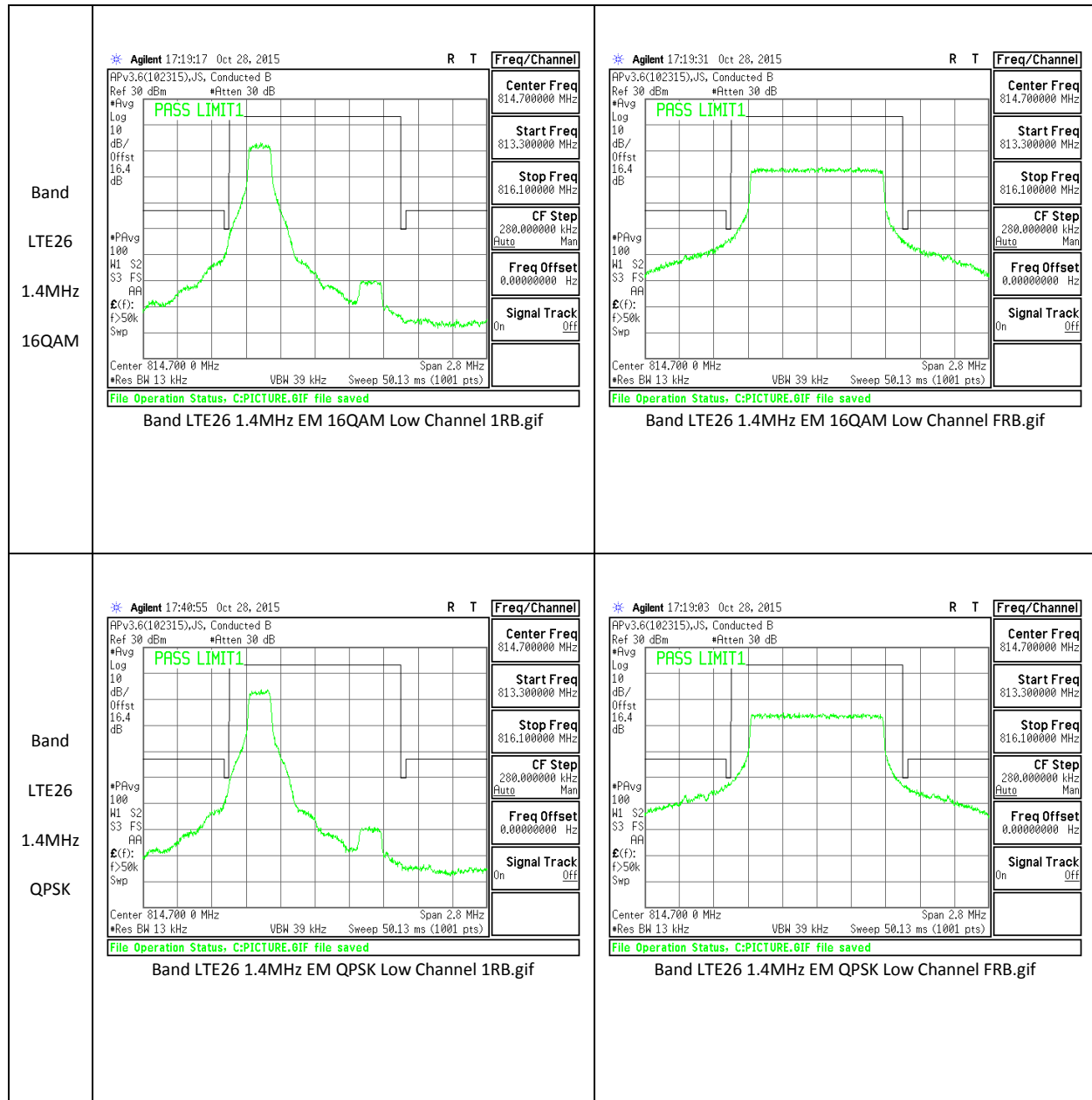

LTE Band 41

