



# TEST REPORT ON HAC

**Model Tested:** SCH-U940  
**FCC ID (Requested) :** A3LSCHU940  
**Job No :** AF-102  
**Report No :** AF-102-M1  
**Date issued :** Dec. 1, 2008  
**Result Summary :** M4 - 2007 (RF EMISSION Category)

- Abstract -

This document reports on HAC Tests carried out in accordance with ANSI C63.19(2007), FCC Rule Part(s) FCC 47 CFR §20.19, §6.3, §7.3

Prepared By

EH JUNG – Test Engineer

Authorized By

JH NAM – Technical Manager



# Contents

<b>1. GENERAL INFORMATION.....</b>	<b>3</b>
<b>2. DESCRIPTION OF DEVICE.....</b>	<b>3</b>
<b>3. DESCRIPTION OF TEST EQUIPMENT.....</b>	<b>4</b>
3.1 HAC Measurement Setup.....	4
3.2 Probe Description.....	6
3.3 Test Arch Phantom.....	7
3.4 Validation Dipole.....	7
3.5 Equipment Calibration.....	8
<b>4. HAC MEASUREMENT PROCEDURE.....</b>	<b>9</b>
<b>5. DESCRIPTION OF TEST POSITION.....</b>	<b>11</b>
5.1 Measurement reference and plane.....	11
<b>6. MEASUREMENT UNCERTAINTY.....</b>	<b>12</b>
<b>7. SYSTEM VERIFICATION.....</b>	<b>13</b>
7.1 Test System Validation.....	13
<b>8. MODULATION FACTOR.....</b>	<b>14</b>
8.1 Modulation Factors.....	15
8.2 CW and Modulated Signal Zero-span plots.....	15
<b>9. FCC 3G MEASUREMENTS – MAY/JUNE 2006.....</b>	<b>16</b>
9.1 Handset Capabilities*.....	16
9.2 Worst-Case Probe Location Measurements.....	16
<b>10. Test Results.....</b>	<b>17</b>
10.1 Measurement Results(E-field) - Slide Down.....	17
10.2 Measurement Results(E-field) - Slide Up.....	18
10.3 Measurement Results(H-field) - Slide Down.....	19
10.4 Measurement Results(H-field) - Slide Up.....	20
10.5 Worst-case Configuration Evaluation.....	21
<b>11. REFERENCES.....</b>	<b>22</b>



## 1. GENERAL INFORMATION

Test Sample : Dual-Band CDMA Phone with Bluetooth

Model Number : SCH-U940

Serial Number : Identical prototype (S/N : # AF-102-A )

Manufacturer : SAMSUNG ELECTRONICS Co., Ltd.

Contact : HY KIM

Phone : +82-54-479-5931

Fax : +82-54-479-5866

Test Standard : ANSI C 63.19 (2007), FCC 47 CFR § 20.19, §6.3, §7.3

FCC Classification : Licensed Portable Transmitter Held to Ear (PCE)

Test Dates : Nov.25 ,2008

Tested for : FCC/TCB Certification

## 2. DESCRIPTION OF DEVICE

Tx Freq. Range : 824.70 ~ 848.31 MHz(CDMA)  
1851.25 ~ 1908.76 MHz(PCS)

Rx Freq. Range : 869.70 ~ 893.31 MHz(CDMA)  
1931.25 ~ 1988.76 MHz(PCS)

Antenna Configuration : SCH-U940

Antenna Manufacturer : PANASONIC

Antenna Dimensions : 34mm\*13mm\*5.48mm

### 3. DESCRIPTION OF TEST EQUIPMENT

#### 3.1 HAC Measurement Setup

##### Robotic System

Measurements are performed using the DASY4(or DASY5) automated dosimetric assessment system. Which is made by Schmid & Partner Engineering AG (SPEAG) in Zurich, Switzerland and consists of high precision robotics system (Staubli), robot controller, measurement server, Samsung computer, near-field probe, probe alignment sensor, and the SAM twin phantom containing the brain equivalent material. The robot is a six-axis industrial robot performing precise movements to position the probe to the location (points) of maximum electromagnetic field (EMF) (see Fig. 3.1).

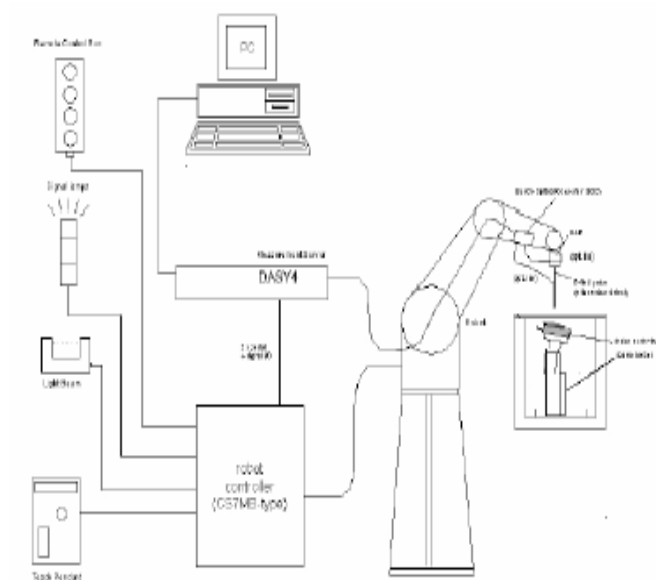


Figure 3.1 HAC Measurement System Setup

##### System Hardware

A cell controller system contains the power supply, robot controller, teach pendant (Joystick), and a remote control is used to drive the robot motors. The PC consists of the Samsung computer with Windows XP system and HAC Measurement Software DASY4(or DASY5), LCD monitor, mouse and keyboard. The Staubli Robot is connected to the cell controller to allow software manipulation of the robot. A



data acquisition electronic (DAE) circuit that performs the signal amplification, signal multiplexing, AD-conversion, offset measurements, mechanical surface detection, collision detection, etc. is connected to the Electro-optical coupler (EOC). The EOC performs the conversion from the optical into digital electric signal of the DAE and transfers data to the measurement server

### **System Electronics**

The DAE4(or DAE3) consists of a highly sensitive electrometer-grade preamplifier with auto-zeroing, a channel and gain-switching multiplexer, a fast 16-bit AD-converter and a command decoder and control logic unit. Transmission to the measurement server is accomplished through an optical downlink for data and status information and an optical uplink for commands and clock lines. The mechanical probe mounting device includes two different sensor systems for frontal and sidewise probe contacts. They are also used for mechanical surface detection and probe collision detection. The robot uses its own controller with a built in VME-bus computer.

### 3.2 Probe Description

#### ER3DV6 E-Field Probe Description

Construction: One dipole parallel, two dipoles normal to probe axis  
Built-in shielding against static charges

Calibration: In air from 100 MHz to 3.0 GHz  
(absolute accuracy  $\pm 6.0\%$ ,  $k=2$ )

Frequency: 100 MHz to > 6 GHz;  
Linearity:  $\pm 0.2$  dB (100 MHz to 3 GHz)

Directivity  $\pm 0.2$  dB in air (rotation around probe axis)  
 $\pm 0.4$  dB in air (rotation normal to probe axis)

Dynamic Range 2V/m to 1000V/m  
(M3 or better device readings fall well below diode compression point)

Linearity :  $\pm 0.2$ dB

Dimensions Overall length: 330 mm (Tip: 16 mm)  
Tip diameter: 8 mm (Body: 12 mm)  
Distance from probe tip to dipole centers: 2.5 mm



Figure 3.2 E-field Probe

#### H3DV6 H-Field Probe Description

Construction: Three concentric loop sensors with 3.8 mm loop diameters Resistively loaded detector diodes for linear response Built-in shielding against static charges

Frequency: 200 MHz to 3 GHz (absolute accuracy  $\pm 6.0\%$ ,  $k=2$ ); Output linearized

Directivity:  $\pm 0.25$  dB (spherical isotropy error)

Dynamic Range: 10mA/mto2A/mat1 GHz  
(M3 or better device readings fall well below diode compression point)

Dimensions: Overall length: 330 mm (Tip: 40 mm)  
Tip diameter: 6 mm (Body: 12 mm)  
Distance from probe tip to dipole centers: 3 mm

E-Field Interference < 10% at 3 GHz (for plane wave)



Figure 3.3 H-field Probe

### 3.3 Test Arch Phantom

Enables easy and well defined positioning of the phone and calibration dipoles as well as simple teaching of the robot (See Figure 3.4)

Dimensions: 370 x 370 x 370 mm

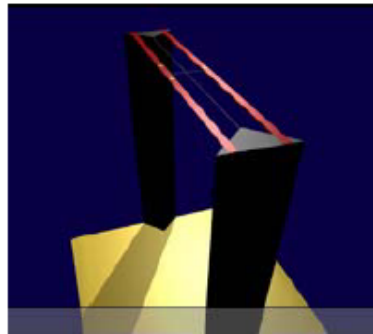


Figure 3.4 Test Arch Phantom

### 3.4 Validation Dipole

The reference dipole should have a return loss better than  $-20$  dB (measured in the setup) at the resonant frequency to reduce the uncertainty in the power measurement.

Application	<ul style="list-style-type: none"> <li>- Free space antenna</li> <li>- Hearing Aid susceptibility measurements according to ANSI C 63.19</li> <li>- Validation of Hearing Aid RF setup for wireless device emission measurement according to ANSI C63.19</li> </ul>
Frequency	835 MHz, 1880 MHz, 2450 MHz
Return Loss	< -20 dB at specified validation position
Dimensions	835 MHz : 166 x 330 mm 1880MHz : 80.8 x 330 mm 2450MHz : 59.9 x 330 mm

### 3.5 Equipment Calibration

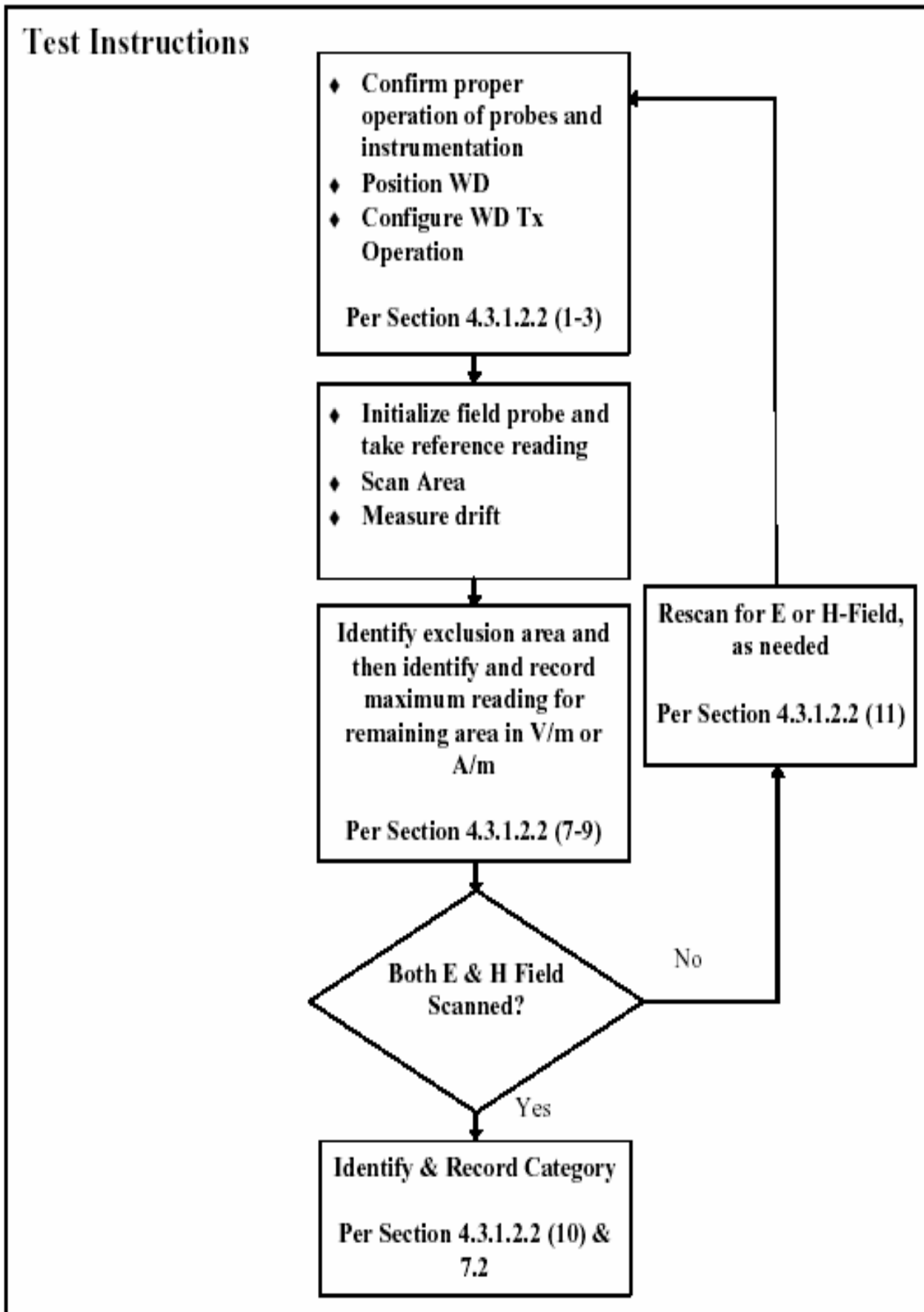
**Table 3.2 Test Equipment Calibration**

Type	Calibration Due Date	Serial No.
Stäubli Robot RX90BL	Not Required	F05/51G6A1/A/01
HAC Phantom	Not Required	1018
SPEAG DAE4	2009.02.28	686
SPEAG E-Field Probe ER3DV6	2009.04.21	2370
SPEAG H-Field Probe H3DV6	2009.04.21	6197
SPEAG Validation Dipole CD835 V3	2009.03.21	1021
SPEAG Validation Dipole CD1880 V3	2009.03.21	1016
E4438C Signal Generator	2009.01.31	MY45094010
BBS3Q7ECK Power Amp	2009.01.07	1023
E4419B Power Meter	2009.05.02	MY45101764
E9300B Power Sensor	2009.05.02	MY52505880
E9300B Power Sensor	2009.05.02	MY41495894
DASY4 S/W (ver 4.7)	Not Required	-
Directional Coupler	2009.03.31	20412
Spectrum Analyzer	2009.01.31	MY46186167
Base Station Simulator	2009.02.01	GB45360270

**NOTE:**

The E-field and H-field probe was calibrated by SPEAG,

#### 4. HAC MEASUREMENT PROCEDURE





The evaluation was performed using the following procedure.

1. Confirm proper operation of the field probe, probe measurement system, and other instrumentation.
2. WD is positioned in its intended test position, acoustic output point of the device perpendicular to the field probe.
3. The WD operation for maximum rated RF output power was configured and confirmed with the base station simulator, at the test channel and other normal operating parameters as intended for the test. The battery was ensured to be fully charged before each test.
4. The center sub-grid was centered over the center of the acoustic output (also audio band magnetic output, if applicable). The WD audio output was positioned tangent (as physically possible) to the measurement plane.
5. A surface calibration was performed before each setup change to ensure repeatable spacing and proper maintenance of the measurement plane using the HAC Phantom.
6. The measurement system measured the field strength at the reference location.
7. Measurements at 2mm increments in the 5 x 5 cm region were performed and recorded. A 360° rotation about the azimuth axis at the maximum interpolated position was measured. For the worst-case condition, the peak reading from this rotation was used in re-evaluating the HAC category.
8. The system performed a drift evaluation by measuring the field at the reference location.
9. Steps 1-8 were done for both the E and H-Field measurements.
10. The HAC measurement software calculates a reference point at the start and end of the test to check for power drifts. If conducted power deviations of more than 5% occurred, the tests were repeated.

## 5. DESCRIPTION OF TEST POSITION

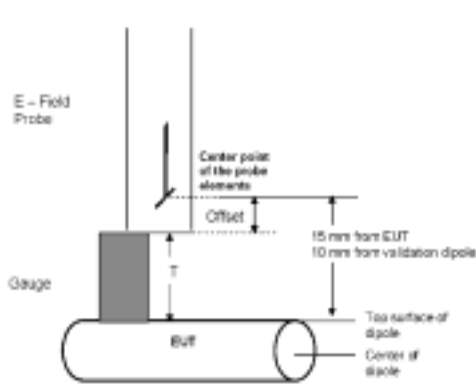
### 5.1 Measurement reference and plane

1. The grid is 5 cm by 5 cm area that is divided into 9 evenly sized blocks or sub-grids.
2. The grid is centered on the audio frequency output transducer of the WD (speaker or T- coil).
3. The grid is in a reference plane, which is defined as the planar area that contains the highest point in the area of the phone that normally rests against the user's ear. It is parallel to the centerline of the receiver area of the phone and is defined by the points of the receiver-end of the WD handset, which, in normal handset use,

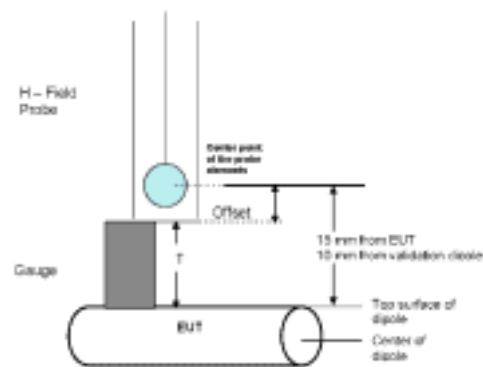


**Figure 5.1 Wireless Device and Measurement Plane**

4



**Figure 5.2 Gauge block with E-field probe**



**Figure 5.3 Gauge block with H-field probe**



## 6.Measurement Uncertainty

Source of Uncertainty	Value	probability distribution	Divisor	$c_i$ E	$c_i$ H	Standard uncertainty		vi or veff	
						E	H	E	H
<b>Measurement System</b>									
Probe Calibration	5.05	normal	1.000	1	1	5.05	2.55	0	0
Axial Isotropy	4.70	rectangular	1.732	1	1	2.71	2.71	$\infty$	$\infty$
Sensor Displacement	16.50	rectangular	1.732	1	0.145	9.53	1.38	$\infty$	$\infty$
Boundary Effects	2.40	rectangular	1.732	1	1	1.39	1.39	$\infty$	$\infty$
Linearity	4.70	rectangular	1.732	1	1	2.71	2.71	$\infty$	$\infty$
Scaling to Peak Envelop Power	2.00	rectangular	1.732	1	1	1.15	1.15	$\infty$	$\infty$
System Detection Limit	1.00	rectangular	1.732	1	1	0.58	0.58	$\infty$	$\infty$
Readout Electronics	0.30	normal	1.000	1	1	0.30	0.30	$\infty$	$\infty$
Response Time	0.80	rectangular	1.732	1	1	0.46	0.46	$\infty$	$\infty$
Integration time	2.60	rectangular	1.732	1	1	1.50	1.50	$\infty$	$\infty$
RF Ambient condition	3.00	rectangular	1.732	1	1	1.73	1.73	$\infty$	$\infty$
RF Reflections	3.92	normal	1.000	1	1	3.92	3.92	2	2
Probe Positioner	1.20	rectangular	1.732	1	0.67	0.69	0.46	$\infty$	$\infty$
Probe Positioning	4.70	rectangular	1.732	1	0.67	2.71	1.82	$\infty$	$\infty$
Variability between 2mm & 5mm	3.85	normal	1.000	1	1	3.85	3.85	4	4
Extrap. And Interpolation	1.00	rectangular	1.732	1	1	0.58	0.58	$\infty$	$\infty$
<b>Test Sample Related</b>									
Device Positioning	0.57	normal	1.000	1	0.67	0.57	0.38	24	24
Device Holder and Phantom	2.40	rectangular	1.732	1	1	1.39	1.39	$\infty$	$\infty$
Power Drift	5.00	rectangular	1.732	1	1	2.89	2.89	$\infty$	$\infty$
<b>Phantom and Setup Related</b>									
Phantom Thickness	2.40	rectangular	1.732	1	0.7	1.39	0.93	$\infty$	$\infty$
$u_c(F_S)$	<b>Combined Standard Uncertainty</b>		<b>normal</b>			<b>13.82</b>	<b>9.83</b>	211	54
$U(F_S)$	<b>Expanded Uncertainty</b>		<b>normal k=</b>	<b>2.0</b>		<b>27.09</b>	<b>19.26</b>		

## 7. SYSTEM VERIFICATION

### 7.1 Test System Validation

Prior to assessment, the system is verified to the  $\pm 10\%$  of the specification at 835MHz, 1880MHz, by using the system validation kit(s). (see Appendix C, Graphic Plot Attached)

**Table 7.2 System Validation Results**\*Validation was measured with input power 100mW

Frequency	Targeted E-field (V/m)	Measured E-field (V/m)	Deviation (%)	Targeted H-field (A/m)	Measured H-field (A/m)	Deviation (%)	Date
835 MHz	163.75	166.25	1.53	0.451	0.433	-3.99	Nov.25, 2008
1880 MHz	133.55	141.85	6.21	0.444	0.448	0.90	Nov.25, 2008

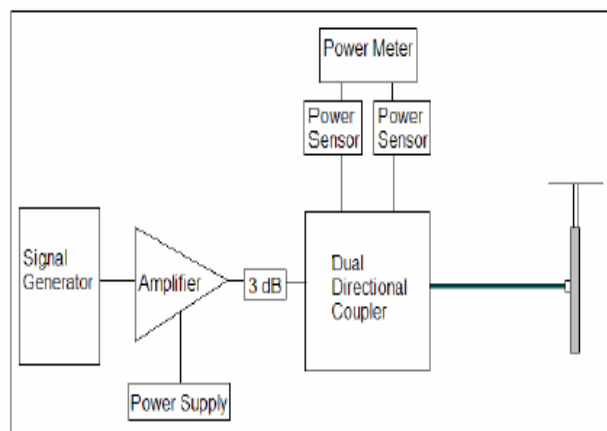


Figure 7.1 Dipole Validation Test Setup

Validations of the DASY4(or DASY5) test system were performed using the measurement equipment listed in Section 3.2. All validations occur in free space using the DASY4(or DASY5) test arch. Note that the 10mm probe to dipole separation is measured from the top edge of the dipole to the calibration reference point of the probe. SPEAG uses the center point of the probe sensor(s) as the reference point when establishing targets for their dipoles. Therefore, because SPEAG's dipoles and targets are used, it is appropriate to measure the 10mm separation distance to the center of the sensors as they do. This reference point was used for validation only. Validations were performed at 835 MHz and/or 1880 MHz. These frequencies are within each operating band and are within 2MHz of the mid-band frequency of the test device. The obtained results from the validations are displayed in the table 7.2.

## 8. MODULATION FACTOR

After every probe calibration, the response of the probe to each applicable modulated signal (CDMA, GSM, etc) must be assessed at both 835 MHz and 1880 MHz. The response of the probe system to a CW field at the frequency(s) of interest is compared to its response to a modulated signal with equal peak amplitude. For each PMF assessment, a Signal Generator was used to replace the original CW signal with the desired modulated signal. The PMF results are shown in Tables 5.

RF Field Probe Modulation Response was measured with the field probe and associated measurement equipment. The proposed setup corresponds to the procedure as required in the Standard.

1. Install a validation dipole for the appropriate frequency band under the Test Arch Phantom. Move the probe to the field reference point. Do not move the probe between the corresponding CW and modulated measurements.
2. Install the field probe in the setup.
3. The signal to the dipole must be monitored to record peak amplitude. Set a CW signal to the same level (refer to Appendix B)
4. Set the procedure properties (frequency, modulation frequency and crest factor) according to the measured signal. Define a multimeter job for the field reading.
5. Define a second procedure for the evaluation of the CW signal (frequency set as above, modulation frequency = 0, crest factor = 1) and a multimeter job.
6. The ratio of the CW reading to modulated signal reading is the probe modulation factor(PMF) for the modulation and field probe combination. This was repeated for 80% AM.
7. Steps 1-6 were repeated at all frequency bands and for both E and H field probes.

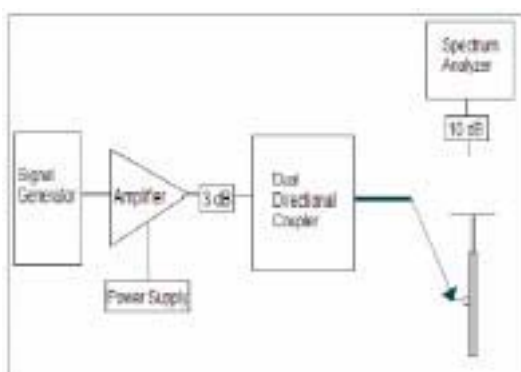


Figure 8.1 Setup to Dipole

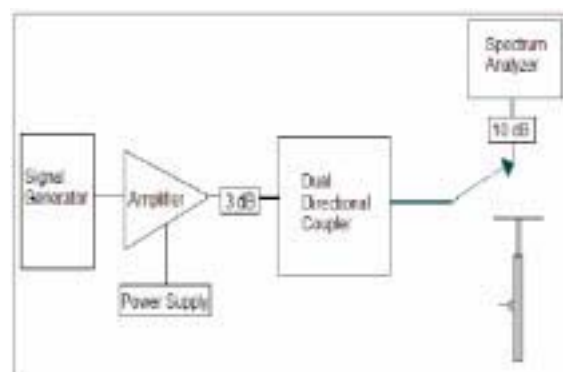


Figure 8.2 Setup to Peak Power using Spectrum Analyzer

### 8.1 Modulation Factors

Frequency	Protocol	E-field (V/m)	H-field (A/m)	E-Field PMF	H-Field PMF
835 MHz	AM	48.6	0.103	1.56	1.58
835 MHz	CDMA	74.5	0.160	1.01	1.02
835 MHz	CW	75.6	0.163	-	-
1880 MHz	AM	28.7	0.082	1.51	1.53
1880 MHz	CDMA	44.2	0.125	0.98	1.01
1880 MHz	CW	43.4	0.126	-	-
-	-	-	-	-	-
-	-	-	-	-	-
-	-	-	-	-	-
1880 MHz	CDMA/SO3	15.1	-	2.800	-
1880 MHz	CW	42.3	-	-	-

Table 8.1 Modulation Factors

### 8.2 CW and Modulated Signal Zero-span plots:

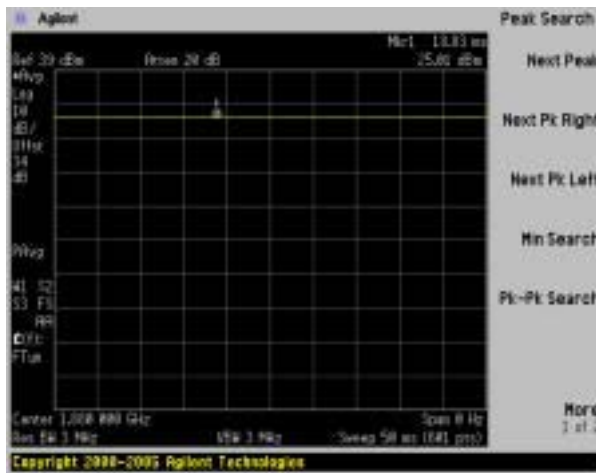


Figure 8.3 CW Signal

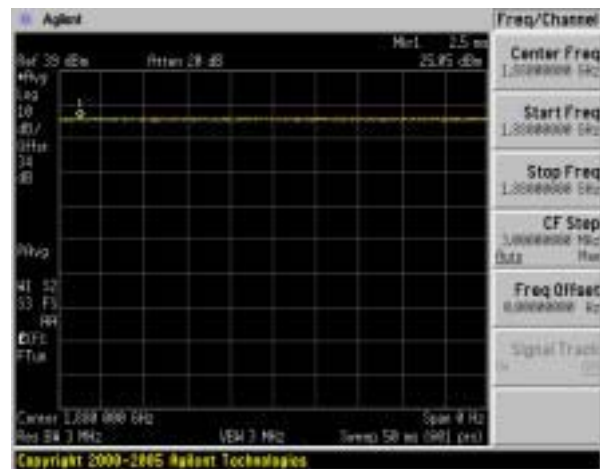


Figure 8.4 CDMA Signal

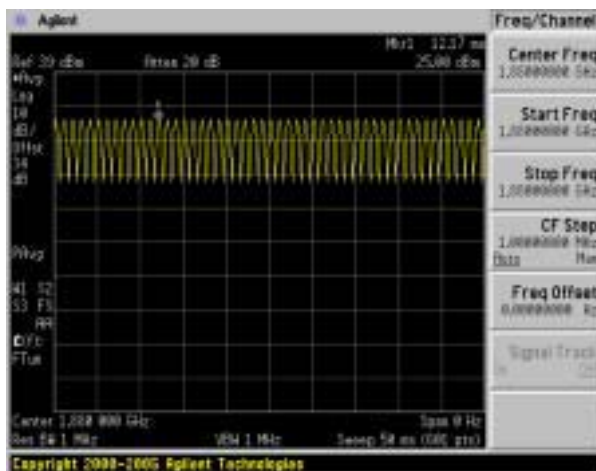


Figure 8.5 AM 80% Signal

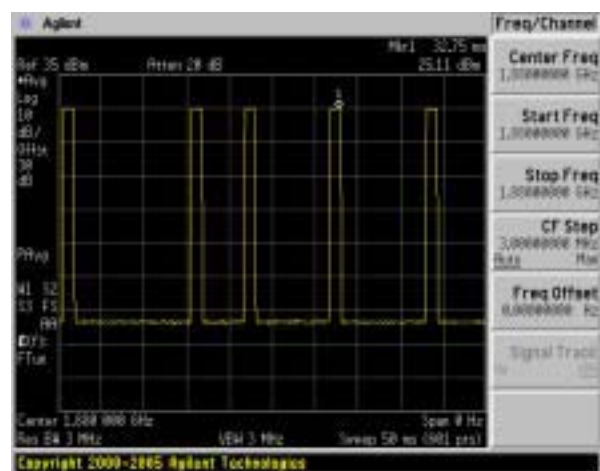


Figure 8.6 1/8 rate Signal



## 9. FCC 3G MEASUREMENTS – MAY/JUNE 2006

Sample pre-testing of the various modes were performed at the worst case probe location as part of subset testing justification. See below for measured conducted power for applicable device modes.

### 9.1 Handset Capabilities\*

\* See Device Capabilities attachment for applicable device modes and powers



### 9.2 Worst-Case Probe Location Measurements

Below are RC/SO mode investigation results of the device at the worst-case(maximum) field point location.

Mode	Channel	Back light	RC/SO	Battery	Antenna	Conducted Power at BS(dBm)	Time Avg. Field [V/m]	Peak Field [V/m]	Peak Field [dBV/m]	Category	FCC limit [dBV/m]	FCC Margin [dB]
<b>E-field Emissions -Slide Close</b>												
PCS	25	off	RC3/SO55	Standard	Intenna	25.1	43.9	42.99	32.67	M4	41.0	-8.33
PCS	25	on	RC3/SO55	Standard	Intenna	25.1	43.8	42.93	32.66	M4	41.0	-8.34
PCS	25	off	RC1/SO2	Standard	Intenna	24.9	43.2	42.36	32.54	M4	41.0	-8.46
PCS	25	off	RC3/SO2	Standard	Intenna	25.0	43.6	42.77	32.62	M4	41.0	-8.38
PCS	25	off	RC1/SO55	Standard	Intenna	24.9	43.0	42.16	32.50	M4	41.0	-8.50
PCS	25	off	RC2/SO9	Standard	Intenna	24.9	43.1	42.20	32.51	M4	41.0	-8.49
PCS	25	off	RC1/SO3	Standard	Intenna	25.1	15.2	42.45	32.56	M4	41.0	-8.44
PCS	25	off	RC3/SO3	Standard	Intenna	24.8	43.8	42.91	32.65	M4	41.0	-8.35
PCS	25	off	RC2/SO17	Standard	Intenna	24.8	15.3	42.87	32.64	M4	41.0	-8.36
PCS	25	off	RC3/SO55	Extended	Intenna	24.8	43.8	42.88	32.65	M4	41.0	-8.35

Table 9-1 Handset 3G mode variation on RF Emission



## 10. Test Results

### 10.1 Measurement Results(E-field) Slide-Close

#### E-FIELD EMISSIONS:

Mode	Channel	Back light	RC/SO	Battery	Antenna	Conducted Power at BS(dBm)	Time Avg. Field [V/m]	Peak Field [V/m]	Peak Field [dBV/m]	Category	FCC limit [dBV/m]	FCC Margin [dB]	Excl Blocks Per 4.3.1.2.2
<b>E-field Emissions</b>													
CDMA	1013	off	RC3/SO55	Standard	Intenna	25.4	56.6	57.2	35.15	M4	51.0	-15.85	None
CDMA	384	off	RC3/SO55	Standard	Intenna	25.8	69.8	70.5	36.96	M4	51.0	-14.04	None
CDMA	777	off	RC3/SO55	Standard	Intenna	25.6	74.3	75.0	37.50	M4	51.0	-13.50	None
PCS	25	off	RC3/SO55	Standard	Intenna	25.1	44.2	43.3	32.73	M4	41.0	-8.27	None
PCS	600	off	RC3/SO55	Standard	Intenna	25.3	43.1	42.2	32.51	M4	41.0	-8.49	None
PCS	1175	off	RC3/SO55	Standard	Intenna	25.0	40.6	39.8	32.00	M4	41.0	-9.00	None
PCS	25	on	RC3/SO55	Standard	Intenna	25.1	43.9	43.00	32.67	M4	41.0	-8.33	None
PCS	25	off	RC3/SO55	Extended	Intenna	25.3	41.3	40.5	32.15	M4	41.0	-8.85	None

#### NOTES:

- The test data reported are the worst-case HAC value with the test position set in a typical configuration. Test procedures used are according to ANSI C 63.19 (2007).
- All modes of operation were investigated, and the worst-case results are reported.
- Battery is fully charged for all readings.
- \*Power Measured  Conducted
- Battery Option  Standard  Extended  Slim
- Bluetooth deactivated (According to customer's request)

Note: Worst-case measurement evaluated for worst-case 1/8 rate gating condition in RC1/SO3; Mute=Yes



## 10.2 Measurement Results(E-field) - Slide-Open

### E-FIELD EMISSIONS:

Mode	Channel	Back light	RC/SO	Battery	Antenna	Conducted Power at BS(dBm)	Time Avg. Field [V/m]	Peak Field [V/m]	Peak Field [dBV/m]	Category	FCC limit [dBV/m]	FCC Margin [dB]	Excl Blocks Per 4.3.1.2.2
<b>E-field Emissions</b>													
CDMA	1013	off	RC3/SO55	Standard	Intenna	25.4	37.7	38.1	31.62	M4	51.0	-19.38	None
CDMA	384	off	RC3/SO55	Standard	Intenna	25.8	47.1	47.6	33.55	M4	51.0	-17.45	None
CDMA	777	off	RC3/SO55	Standard	Intenna	25.6	46.9	47.4	33.52	M4	51.0	-17.48	None
PCS	25	off	RC3/SO55	Standard	Intenna	25.1	43.3	42.4	32.55	M4	41.0	-8.45	None
PCS	600	off	RC3/SO55	Standard	Intenna	25.3	40.2	39.4	31.91	M4	41.0	-9.09	None
PCS	1175	off	RC3/SO55	Standard	Intenna	25.0	40.0	39.2	31.87	M4	41.0	-9.13	None

### NOTES:

- The test data reported are the worst-case HAC value with the test position set in a typical configuration. Test procedures used are according to ANSI C 63.19 (2007).
- All modes of operation were investigated, and the worst-case results are reported.
- Battery is fully charged for all readings.
- \*Power Measured  Conducted
- Battery Option  Standard  Extended  Slim
- Bluetooth deactivated (According to customer's request)

Note: Worst-case measurement evaluated for worst-case 1/8 rate gating condition in RC1/SO3; Mute=Yes



### 10.3 Measurement Results(H-field) - Slide-Close

#### H-FIELD EMISSIONS:

Mode	Channel	Back light	RC/SO	Battery	Antenna	Conducted Power at BS(dBm)	Time Avg. Field [A/m]	Peak Field [A/m]	Peak Field [dBA/m]	Category	FCC limit [dBA/m]	FCC Margin [dB]	Excl Blocks Per 4.3.1.2.2
<b>H-field Emissions</b>													
CDMA	1013	off	RC3/SO55	Standard	Intenna	25.4	0.124	0.126	-17.99	M4	0.6	-18.59	None
CDMA	384	off	RC3/SO55	Standard	Intenna	25.8	0.132	0.135	-17.39	M4	0.6	-17.99	None
CDMA	777	off	RC3/SO55	Standard	Intenna	25.6	0.160	0.163	-15.76	M4	0.6	-16.36	None
PCS	25	off	RC3/SO55	Standard	Intenna	25.1	0.126	0.127	-17.92	M4	-9.4	-8.52	None
PCS	600	off	RC3/SO55	Standard	Intenna	25.3	0.109	0.110	-19.17	M4	-9.4	-9.77	None
PCS	1175	off	RC3/SO55	Standard	Intenna	25.0	0.117	0.118	-18.56	M4	-9.4	-9.16	None

#### NOTES:

1. The test data reported are the worst-case HAC value with the test position set in a typical configuration. Test procedures used are according to ANSI C 63.19 (2007).
2. All modes of operation were investigated, and the worst-case results are reported.
3. Battery is fully charged for all readings.
4. \*Power Measured  Conducted
5. Battery Option  Standard  Extended  Slim
6. Bluetooth deactivated (According to customer's request)

Note: Worst-case measurement evaluated for worst-case 1/8 rate gating condition in RC1/SO3; Mute=Yes



## 10.4 Measurement Results(H-field) - Slide-Open

### H-FIELD EMISSIONS:

Mode	Channel	Back light	RC/SO	Battery	Antenna	Conducted Power at BS(dBm)	Time Avg. Field [A/m]	Peak Field [A/m]	Peak Field [dBA/m]	Category	FCC limit [dBA/m]	FCC Margin [dB]	Excl Blocks Per 4.3.1.2.2
<b>H-field Emissions</b>													
CDMA	1013	off	RC3/SO55	Standard	Intenna	25.4	0.101	0.101	-19.91	M4	0.6	-20.51	None
CDMA	384	off	RC3/SO55	Standard	Intenna	25.8	0.131	0.131	-17.65	M4	0.6	-18.25	None
CDMA	777	off	RC3/SO55	Standard	Intenna	25.6	0.144	0.144	-16.83	M4	0.6	-17.43	None
PCS	25	off	RC3/SO55	Standard	Intenna	25.1	0.114	0.114	-18.86	M4	-9.4	-9.46	None
PCS	600	off	RC3/SO55	Standard	Intenna	25.3	0.103	0.103	-19.74	M4	-9.4	-10.34	None
PCS	1175	off	RC3/SO55	Standard	Intenna	25.0	0.100	0.100	-20.00	M4	-9.4	-10.60	None

### NOTES:

1. The test data reported are the worst-case HAC value with the test position set in a typical configuration. Test procedures used are according to ANSI C 63.19 (2007).
2. All modes of operation were investigated, and the worst-case results are reported.
3. Battery is fully charged for all readings.
4. \*Power Measured  Conducted
5. Battery Option  Standard  Extended  Slim
6. Bluetooth deactivated (According to customer's request)

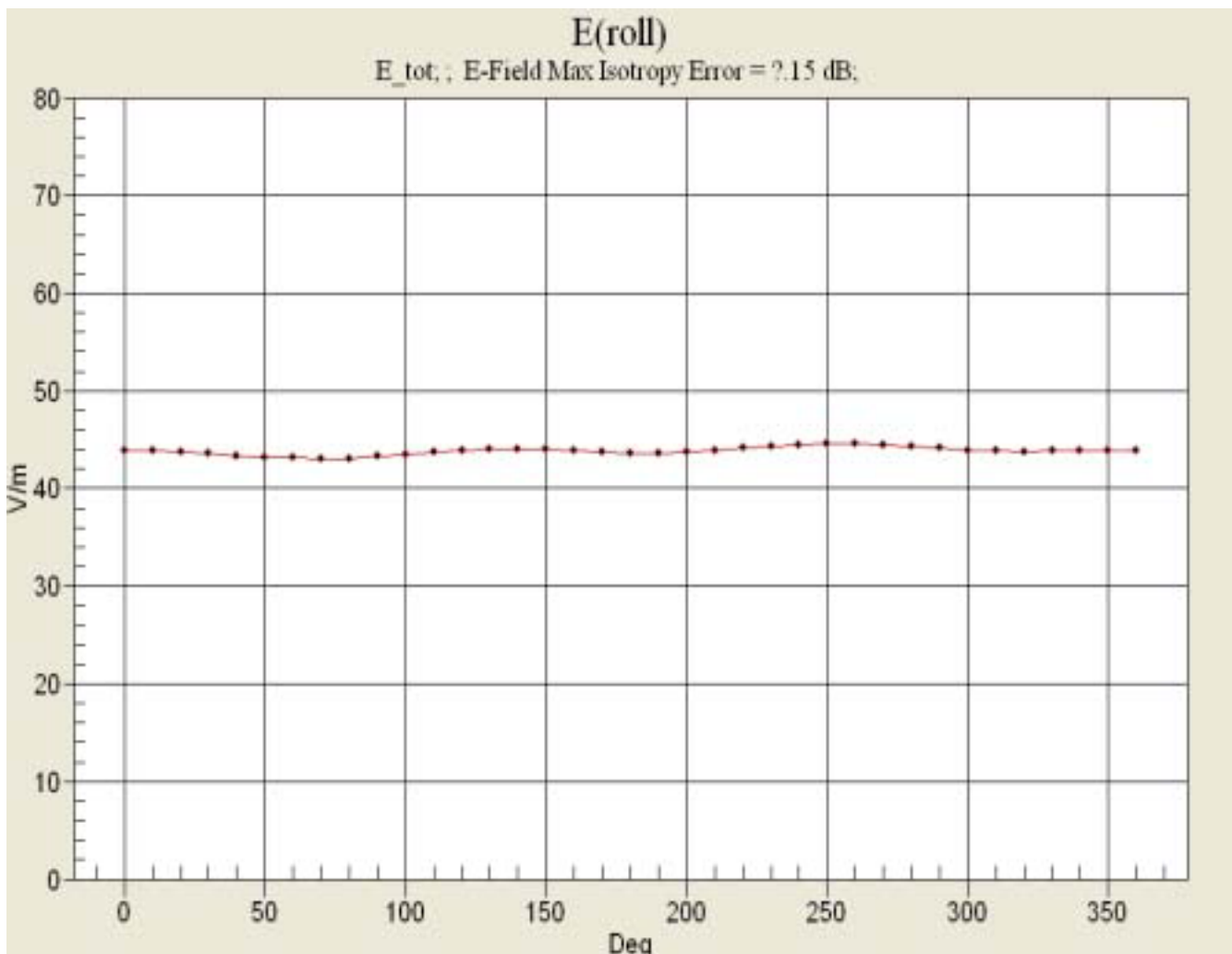
Note: Worst-case measurement evaluated for worst-case 1/8 rate gating condition in RC1/SO3; Mute=Yes

### 10.5 Worst-case Configuration Evaluation

PCS E-field Emission -Slide Close

Mode	Channel	Back light	RC/SO	Battery	Antenna	Conducted Power at BS(dBm)	Time Avg. Field [V/m]	Peak Field [V/m]	Peak Field [dBV/m]	Category	FCC limit [dBV/m]	FCC Margin [dB]
<b>E-field Emission</b>												
PCS	25	off	RC3/SO55	Standard	Intenna	25.1	44.6	43.69	32.81	M4	41.0	-8.19

**Peak Reading 360 degree Probe Rotation at Azimuth axis**



**Worst-Case Probe Rotation about Azimuth axis**

Note: Location of probe rotation is shown in APPENDIX E



## 11. REFERENCES

- [1] ANSI C63.19–2007, American National Standard for Methods of Measurement of Compatibility between Wireless communication devices and Hearing Aids.", New York, NY, IEEE, June. 2008.
- [2] Berger, H. S., "Compatibility Between Hearing Aids and Wireless Devices," Electronic Industries Forum, Boston, MA, May, 1997
- [3] Berger, H. S., "Hearing Aid and Cellular Phone Compatibility: Working Toward Solutions," Wireless Telephones and Hearing Aids: New Challenges for Audiology, Gallaudet University, Washington, D.C., May, 1997 (To be reprinted in the American Journal of Audiology).
- [4] Berger, H. S., "Hearing Aid Compatibility with Wireless Communications Devices," IEEE International Symposium on Electromagnetic Compatibility, Austin, TX, August, 1997.
- [5] Bronaugh, E. L., "Simplifying EMI Immunity (Susceptibility) Tests in TEM Cells," in the 1990 IEEE International Symposium on Electromagnetic Compatibility Symposium Record, Washington, D.C., August 1990, pp. 488–491
- [6] Byrne, D. and Dillon, H., The National Acoustics Laboratory (NAL) New Procedure for Selecting the Gain and Frequency Response of a Hearing Aid, *Ear and Hearing* 7:257–265, 1986.
- [7] Crawford, M. L., "Measurement of Electromagnetic Radiation from Electronic Equipment using TEM Transmission Cells," U.S. Department of Commerce, National Bureau of Standards, NBSIR 73–306, Feb. 1973.
- [8] Crawford, M. L., and Workman, J. L., "Using a TEM Cell for EMC Measurements of Electronic Equipment," U.S. Department of Commerce, National Bureau of Standards. Technical Note 1013, July 1981.
- [9] EHIMA GSM Project, Development phase, Project Report (1st part) Revision A. Technical–Audiological Laboratory and Telecom Denmark, October 1993.
- [10] EHIMA GSM Project, Development phase, Part II Project Report. Technical–Audiological Laboratory and Telecom Denmark, June 1994.
- [11] EHIMA GSM Project Final Report, Hearing Aids and GSM Mobile Telephones: Interference Problems, Methods of Measurement and Levels of Immunity. Technical–Audiological Laboratory and Telecom Denmark, 1995.
- [12] FCC WT Docket No. 01–309 (HAC Waiver 05–166). Cingular Wireless LLC Petition for Waiver of Section 20.19(c)(3)(i)(A) of the Commission's Rules, September 8, 2005.
- [13] HAMPIS Report, Comparison of Mobile phone electromagnetic near field with an upscaled electromagnetic far field, using hearing aid as reference, 21 October 1999.
- [14] Hearing Aids/GSM, Report from OTWIDAM, Technical–Audiological Laboratory and Telecom Denmark, April 1993.
- [15] EEE 100, The Authoritative Dictionary of IEEE Standards Terms, Seventh Edition.



[16] Joyner, K. H., et. al., Interference to Hearing Aids by the New Digital Mobile Telephone System, Global System for Mobile (GSM) Communication Standard, National Acoustic Laboratory, Australian Hearing Series, Sydney 1993.

[17] Joyner, K. H., et. al., Interference to Hearing Aids by the Digital Mobile Telephone System, Global System for Mobile Communications (GSM), NAL Report #131, National Acoustic Laboratory Australian Hearing Series, Sydney, 1995.

[18] Keeker, W. T., Crawford, M. L., and Wilson, W. A., "Construction of a Transverse Electromagnetic Cell", U.S. Department of Commerce, National Bureau of Standards, Technical Note 1011, Nov. 1978.

[19] Konigstein, D., and Hansen, D., "A New Family of TEM Cells with enlarged bandwidth and Optimized working Volume," in the Proceedings of the 7th International Symposium on EMC, Zurich, Switzerland, March 1987; 50:9, pp. 127-132.

[20] Kuk, F., and Hjorstgaard, N. K., "Factors affecting interference from digital cellular telephones," Hearing Journal, 1997; 50:9, pp 32-34.

[21] Ma, M. A., and Kanda, M., "Electromagnetic Compatibility and Interference Metrology," U.S. Department of Commerce, National Bureau of Standards, Technical Note 1099, July 1986, pp.17-43.

[22] Ma, M. A., Sreenivashiah, I. , and Chang, D. C., "A Method of Determining the Emission and Susceptibility Levels of Electrically Small Objects Using a TEM Cell," U.S. Department of Commerce, National Bureau of Standards, Technial Note 1040, July 1981.

[23] McCandless, G. A., and Lyregaard, P. E., Prescription of Gain/Output (POGO) for Hearing Aids, Hearing Instruments 1:16-21, 1983

[24] Skopec, M., "Hearing Aid Electromagnetic Interference from Digital Wireless Telephones," IEEE Transactions on Rehabilitation Engineering, vol. 6, no. 2, pp. 235-239, June 1998.

[25] Technical Report, GSM 05.90, GSM EMC Considerations, European Telecommunications Standards Institute, January 1993.

[26] Victorian, T. A., "Digital Cellular Telephone Interference and Hearing Aid Compatibility—an Update," Hearing Journal 1998; 51:10, pp. 53-60

[27] Wong, G. S. K., and Embleton, T. F. W., eds., AIP Handbook of Condenser Microphones: Theory, Calibration and Measurements, AIP Press.



## APPENDIX A

### Probe Modulation Factor

#### Measurement procedure

1. Modulated signal measurement: Connect the modulated signal with the correct frequency via the cable to the dipole.
2. Run the multimeter in the procedure with the corresponding modulation setting in continuous mode.
3. Adjust the signal amplitude to achieve the same field level display in the multimeter as during the WD field scan. Read the multimeter display and note it together with the probe ID, modulation type and frequency.
4. Read the peak envelope on the monitor in order to adjust the CW signal later to the same level.
5. Switch the signal source off and verify that the ambient and instrumentation noise level is at least 10dB lower.
6. CW measurement: Change the signal to CW at the same center frequency, without touching or moving the dipole or probe in the setup.
7. Adjust the CW signal amplitude to the same peak level on the monitor.
8. Run the multimeter in the CW procedure in continuous mode.
9. Read the multimeter display and note it together with the probe ID, modulation type and frequency.
10. Calculate the Probe Modulation Factor as the ratio between the CW multimeter field reading and the r for the applicable modulation.
11. Perform the above setup and procedure for E-field and H-field probes.

#### Spectrum Analyzer setting.

1. Frequency Setting

ex) 835 MHz, 1880MHz, 2450 MHz

2. RBW/VBW/SPAN/Detector Setting.

	CW	GSM	CDMA	WCDMA	AM80%
RBW	Same setting with modulated signal respectively.	1MHz	3MHz	5MHz	1MHz
VBW		1MHz	3MHz	5MHz	1MHz
SPAN		0MHz	0MHz	0MHz	0MHz
DETECTOR		Peak	Average	Average	Peak

3. Trigger: Video or IF trigger, adjusted to give a stable display of the transmission
4. Sweep rate: Sufficiently rapid to permit the transmit pulse to be resolved accurately.



## APPENDIX B

### ANSI C63.19 (2007)- Telephone near-field categories.

Category	Telephone RF Parameters <960MHz				
Near Field	AWF	E-Field Emissions		H-Field Emissions	
Category M1/T1	0	631.0 to 1122.0	V/m	1.91 to 3.39	A/m
	-5	473.2 to 841.4	V/m	1.43 to 2.54	A/m
Category M2/T2	0	354.8 to 631.0	V/m	1.07 to 1.91	A/m
	-5	266.1 to 473.2	V/m	0.80 to 1.43	A/m
Category M3/T3	0	199.5 to 354.8	V/m	0.60 to 1.07	A/m
	-5	149.6 to 266.1	V/m	0.45 to 0.80	A/m
Category M4/T4	0	< 199.5	V/m	< 0.60	A/m
	-5	< 149.6	V/m	< 0.45	A/m
Category	Telephone RF Parameters >960MHz				
Near Field	AWF	E-Field Emissions		H-Field Emissions	
Category M1/T1	0	199.5 to 354.8	V/m	0.60 to 1.07	A/m
	-5	149.6 to 266.1	V/m	0.45 to 0.80	A/m
Category M2/T2	0	112.2 to 199.5	V/m	0.34 to 0.60	A/m
	-5	84.1 to 149.6	V/m	0.25 to 0.45	A/m
Category M3/T3	0	63.1 to 112.2	V/m	0.19 to 0.34	A/m
	-5	47.3 to 84.1	V/m	0.14 to 0.25	A/m
Category M4/T4	0	<63.1	V/m	<0.19	A/m
	-5	<47.3	V/m	<0.14	A/m

Table B.1 Telephone near-field categories in linear units.



Category		Telephone RF Parameters <960MHz			
Near Field	AWF	E-Field Emissions		H-Field Emissions	
Category M1/T1	0	56 to 61	dB (V/m)	+5.6 to +10.6	dB (A/m)
	-5	53.5 to 58.5	dB (V/m)	+3.1 to +8.1	dB (A/m)
Category M2/T2	0	51 to 56	dB (V/m)	+0.6 to +5.6	dB (A/m)
	-5	48.5 to 53.5	dB (V/m)	-1.9 to +3.1	dB (A/m)
Category M3/T3	0	46 to 51	dB (V/m)	-4.4 to +0.6	dB (A/m)
	-5	43.5 to 48.5	dB (V/m)	-6.9 to -1.9	dB (A/m)
Category M4/T4	0	<46	dB (V/m)	< -4.4	dB (A/m)
	-5	< 43.5	dB (V/m)	< -6.9	dB (A/m)
Category		Telephone RF Parameters >960MHz			
Near Field	AWF	E-Field Emissions		H-Field Emissions	
Category M1/T1	0	46 to 51	dB (V/m)	-4.4 to 0.6	dB (A/m)
	-5	43.5 to 48.5	dB (V/m)	-6.9 to -1.9	dB (A/m)
Category M2/T2	0	41 to 46	dB (V/m)	-9.4 to -4.4	dB (A/m)
	-5	38.5 to 43.5	dB (V/m)	-11.9 to -6.9	dB (A/m)
Category M3/T3	0	36 to 41	dB (V/m)	-14.4 to -9.4	dB (A/m)
	-5	33.5 to 38.5	dB (V/m)	-16.9 to -11.9	dB (A/m)
Category M4/T4	0	<36	dB (V/m)	<-14.4	dB (A/m)
	-5	<33.5	dB (V/m)	<-16.9	dB (A/m)

Table B.2 Telephone near-field categories in logarithmic units.



## **APPENDIX C**

### **The Validation Measurements**

**DUT: Dipole 835 MHz; Serial: CD835V3 - SN:1021**  
**Program Name: HAC E-field Dipole, Date : 2008/11/25**  
**Procedure Name: E Scan 10mm above CD 835 MHz**

Communication System: CW; Frequency: 835 MHz; Duty Cycle: 1:1  
 Medium parameters used:  $\sigma = 0$  mho/m,  $\epsilon_r = 1$ ;  $\rho = 1$  kg/m<sup>3</sup>  
 Phantom section: E Dipole Section

DASY4 Configuration:

- Probe: ER3DV6 - SN2370; ConvF(1, 1, 1); Calibrated: 2008-04-21
- Sensor-Surface: (Fix Surface)
- Electronics: DAE4 Sn724; Calibrated: 2008-02-28
- Phantom: HAC Test Arch with Coil; Type: SD HAC P01 BA; Serial: 1018
- Measurement SW: DASY4, V4.7 Build 71; Postprocessing SW: SEMCAD, V1.8 Build 184

**E Scan 10mm above CD 835 MHz/Hearing Aid Compatibility Test (41x361x1):** Measurement grid: dx=5mm, dy=5mm

Maximum value of peak Total field = 167.6 V/m

Probe Modulation Factor = 1.00

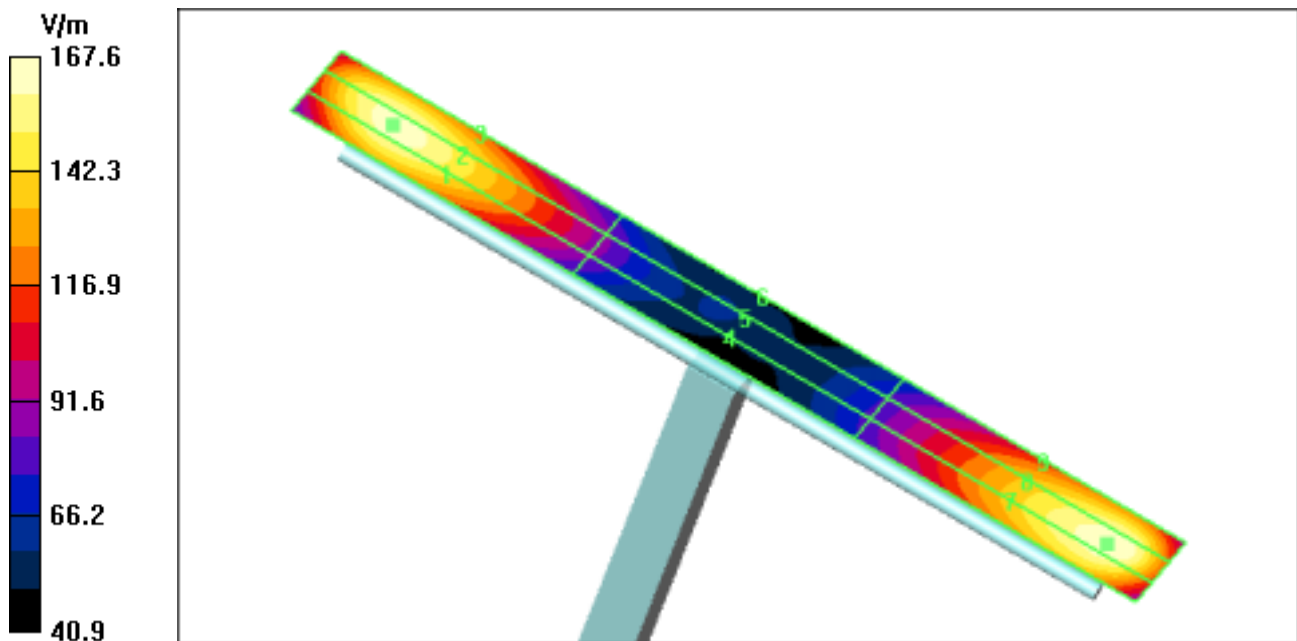
Device Reference Point: 0.000, 0.000, 354.7 mm

Reference Value = 110.2 V/m; Power Drift = -0.004 dB

**Hearing Aid Near-Field Category: M4 (AWF 0 dB)**

Peak E-field in V/m

Grid 1 <b>160.0 M4</b>	Grid 2 <b>164.9 M4</b>	Grid 3 <b>161.1 M4</b>
Grid 4 <b>85.9 M4</b>	Grid 5 <b>88.0 M4</b>	Grid 6 <b>85.8 M4</b>
Grid 7 <b>163.3 M4</b>	Grid 8 <b>167.6 M4</b>	Grid 9 <b>161.1 M4</b>



**DUT: HAC-Dipole 835 MHz; Serial: SN:1021**  
**Program Name: HAC H-field Dipole, Date : 2008/11/25**  
**Procedure Name: H Scan 10mm above CD 835 MHz**

Communication System: CW; Frequency: 835 MHz; Duty Cycle: 1:1  
 Medium parameters used:  $\sigma = 0$  mho/m,  $\epsilon_r = 1$ ;  $\rho = 1$  kg/m<sup>3</sup>  
 Phantom section: H Dipole Section

DASY4 Configuration:

- Probe: H3DV6 - SN6197; ; Calibrated: 2008-04-21
- Sensor-Surface: (Fix Surface)
- Electronics: DAE4 Sn724; Calibrated: 2008-02-28
- Phantom: HAC Test Arch with Coil; Type: SD HAC P01 BA; Serial: 1018
- Measurement SW: DASY4, V4.7 Build 71; Postprocessing SW: SEMCAD, V1.8 Build 184

**H Scan 10mm above CD 835 MHz/Hearing Aid Compatibility Test (41x361x1):** Measurement grid: dx=5mm, dy=5mm

Maximum value of peak Total field = 0.433 A/m

Probe Modulation Factor = 1.00

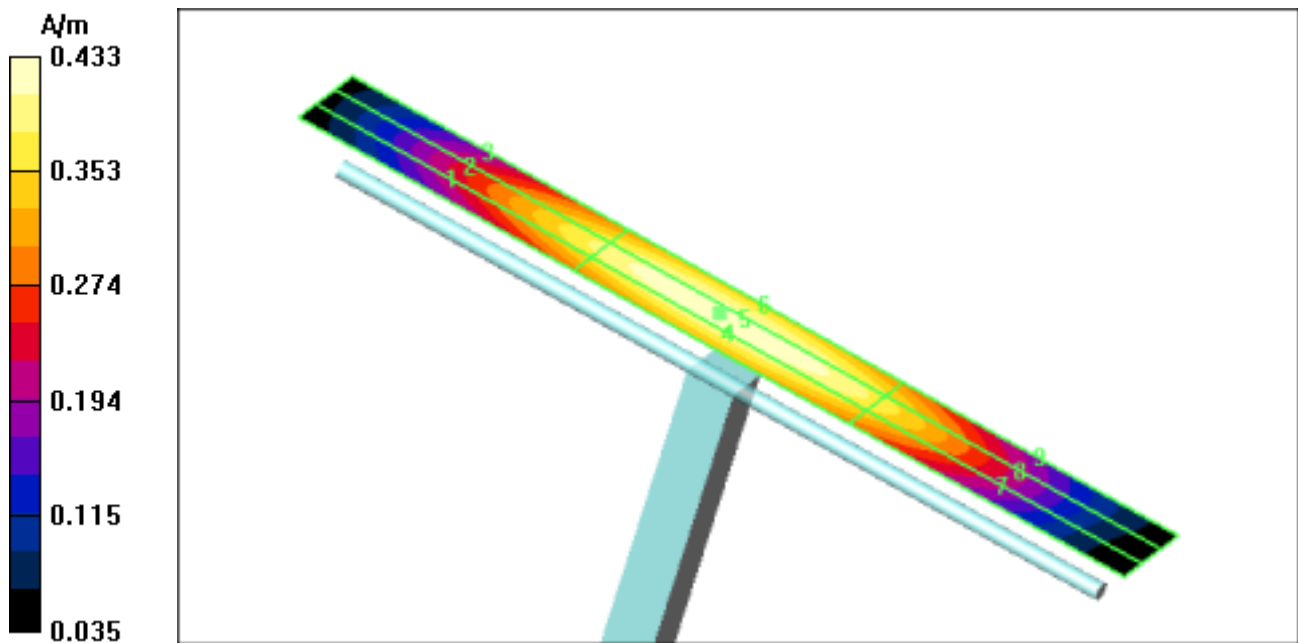
Device Reference Point: 0.000, 0.000, 354.7 mm

Reference Value = 0.458 A/m; Power Drift = 0.016 dB

**Hearing Aid Near-Field Category: M4 (AWF 0 dB)**

Peak H-field in A/m

Grid 1 <b>0.364 M4</b>	Grid 2 <b>0.389 M4</b>	Grid 3 <b>0.375 M4</b>
Grid 4 <b>0.406 M4</b>	Grid 5 <b>0.433 M4</b>	Grid 6 <b>0.417 M4</b>
Grid 7 <b>0.351 M4</b>	Grid 8 <b>0.373 M4</b>	Grid 9 <b>0.359 M4</b>



**DUT: HAC Dipole 1880 MHz; Serial: SN:1016**  
**Program Name: HAC E-field Dipole, Date : 2008/11/25**  
**Procedure Name: E Scan 10mm above CD 1880 MHz**

Communication System: CW; Frequency: 1880 MHz; Duty Cycle: 1:1  
 Medium parameters used:  $\sigma = 0$  mho/m,  $\epsilon_r = 1$ ;  $\rho = 1$  kg/m<sup>3</sup>  
 Phantom section: E Dipole Section

DASY4 Configuration:

- Probe: ER3DV6 - SN2370; ConvF(1, 1, 1); Calibrated: 2008-04-21
- Sensor-Surface: (Fix Surface)
- Electronics: DAE4 Sn724; Calibrated: 2008-02-28
- Phantom: HAC Test Arch with Coil; Type: SD HAC P01 BA; Serial: 1018
- Measurement SW: DASY4, V4.7 Build 71; Postprocessing SW: SEMCAD, V1.8 Build 184

**E Scan 10mm above CD 1880 MHz/Hearing Aid Compatibility Test (41x181x1):** Measurement grid: dx=5mm, dy=5mm

Maximum value of peak Total field = 142.2 V/m

Probe Modulation Factor = 1.00

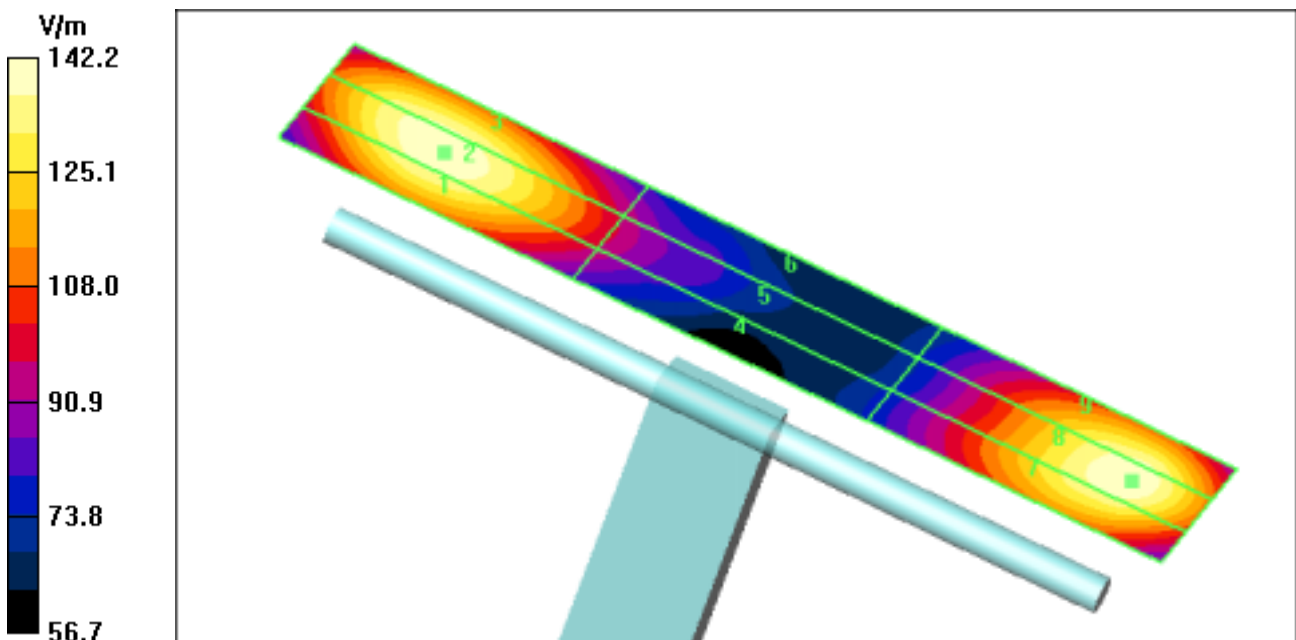
Device Reference Point: 0.000, 0.000, 354.7 mm

Reference Value = 158.8 V/m; Power Drift = -0.010 dB

**Hearing Aid Near-Field Category: M2 (AWF 0 dB)**

Peak E-field in V/m

Grid 1 <b>137.5 M2</b>	Grid 2 <b>141.5 M2</b>	Grid 3 <b>138.4 M2</b>
Grid 4 <b>95.8 M3</b>	Grid 5 <b>98.6 M3</b>	Grid 6 <b>95.3 M3</b>
Grid 7 <b>136.3 M2</b>	Grid 8 <b>142.2 M2</b>	Grid 9 <b>138.8 M2</b>



**DUT: HAC Dipole 1880 MHz; Serial: SN:1016**  
**Program Name: HAC H-field Dipole, Date : 2008/11/25**  
**Procedure Name: H Scan 10mm above CD 1880 MHz**

Communication System: CW; Frequency: 1880 MHz; Duty Cycle: 1:1  
 Medium parameters used:  $\sigma = 0$  mho/m,  $\epsilon_r = 1$ ;  $\rho = 1$  kg/m<sup>3</sup>  
 Phantom section: H Dipole Section

**DASY4 Configuration:**

- Probe: H3DV6 - SN6197; ; Calibrated: 2008-04-21
- Sensor-Surface: (Fix Surface)
- Electronics: DAE4 Sn724; Calibrated: 2008-02-28
- Phantom: HAC Test Arch with Coil; Type: SD HAC P01 BA; Serial: 1018
- Measurement SW: DASY4, V4.7 Build 71; Postprocessing SW: SEMCAD, V1.8 Build 184

**H Scan 10mm above CD 1880 MHz/Hearing Aid Compatibility Test (41x181x1):** Measurement grid: dx=5mm, dy=5mm

Maximum value of peak Total field = 0.448 A/m

Probe Modulation Factor = 1.00

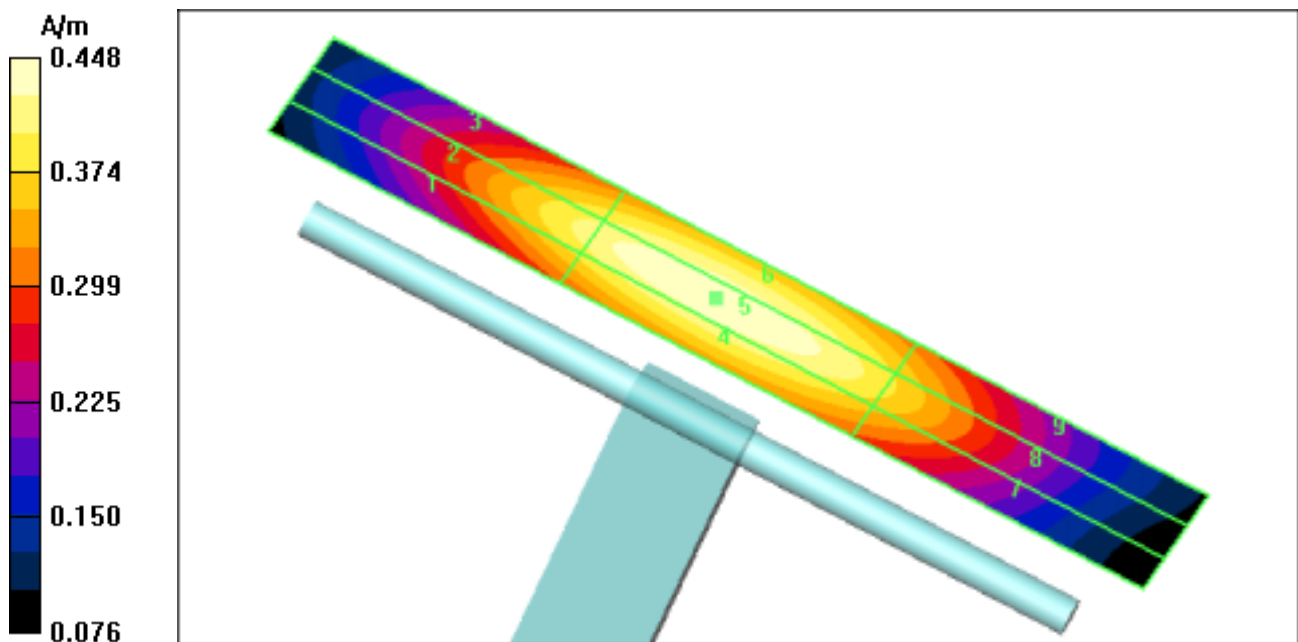
Device Reference Point: 0.000, 0.000, 354.7 mm

Reference Value = 0.446 A/m; Power Drift = -0.007 dB

**Hearing Aid Near-Field Category: M2 (AWF 0 dB)**

Peak H-field in A/m

Grid 1 <b>0.385 M2</b>	Grid 2 <b>0.413 M2</b>	Grid 3 <b>0.398 M2</b>
Grid 4 <b>0.420 M2</b>	Grid 5 <b>0.448 M2</b>	Grid 6 <b>0.432 M2</b>
Grid 7 <b>0.360 M2</b>	Grid 8 <b>0.382 M2</b>	Grid 9 <b>0.370 M2</b>





## **APPENDIX D**

### **Plots of The HAC Measurements**

**DUT: SCH-U940; Serial: AF-102-A**

**Program Name: SCH-U940(CDMA), E-Field, Slide Close Date: 2008/11/24**

**Procedure Name: Ch.1013, Ant, Intenna, Bat. Standard(RC3/SO55)**

Communication System: CDMA(HAC); Frequency: 824.7 MHz; Duty Cycle: 1:1

Medium parameters used:  $\sigma = 0$  mho/m,  $\epsilon_r = 1$ ;  $\rho = 1$  kg/m<sup>3</sup>

Phantom section: E Device Section

DASY4 Configuration:

- Probe: ER3DV6 - SN2370; ConvF(1, 1, 1); Calibrated: 2008-04-21

- Sensor-Surface: (Fix Surface)

- Electronics: DAE4 Sn724; Calibrated: 2008-02-28

- Phantom: HAC Test Arch with Coil; Type: SD HAC P01 BA; Serial: 1018

- Measurement SW: DASY4, V4.7 Build 71; Postprocessing SW: SEMCAD, V1.8 Build 184

### **Ch.1013, Ant, Intenna, Bat. Standard(RC3/SO55)/Hearing Aid Compatibility Test**

**(101x101x1):** Measurement grid: dx=5mm, dy=5mm

Maximum value of peak Total field = 57.2 V/m

Probe Modulation Factor = 1.01

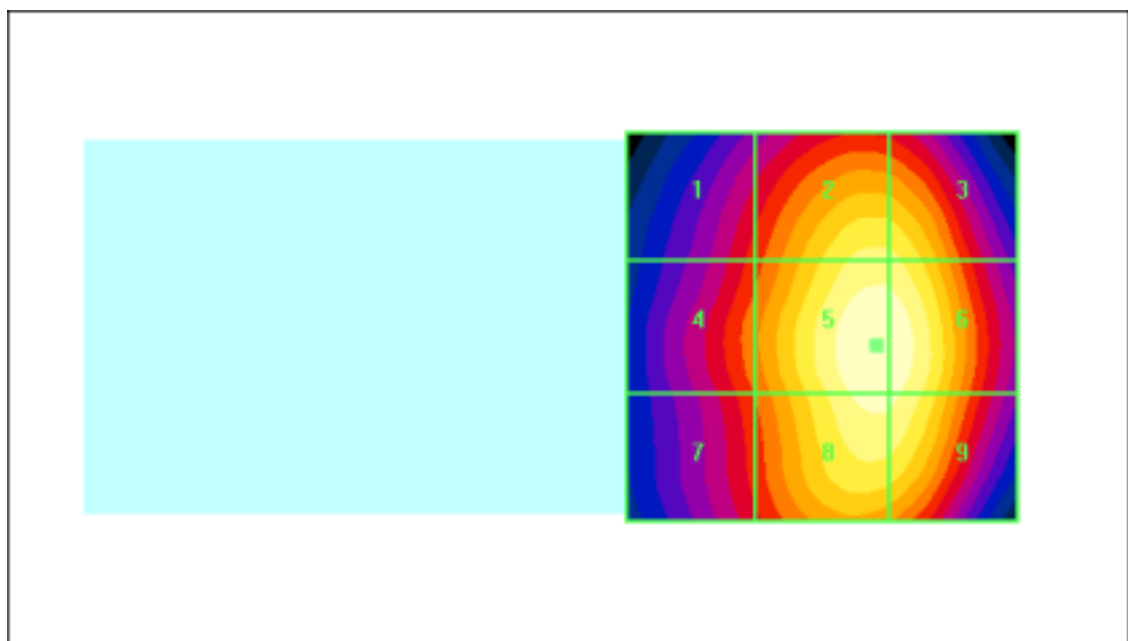
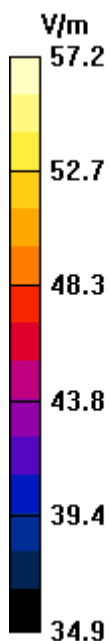
Device Reference Point: 0.000, 0.000, 353.7 mm

Reference Value = 70.1 V/m; Power Drift = 0.063 dB

**Hearing Aid Near-Field Category: M4 (AWF 0 dB)**

Peak E-field in V/m

Grid 1 <b>47.7 M4</b>	Grid 2 <b>54.8 M4</b>	Grid 3 <b>54.7 M4</b>
Grid 4 <b>49.5 M4</b>	Grid 5 <b>57.2 M4</b>	Grid 6 <b>57.0 M4</b>
Grid 7 <b>48.5 M4</b>	Grid 8 <b>56.3 M4</b>	Grid 9 <b>56.2 M4</b>



**DUT: SCH-U940; Serial: AF-102-A**

**Program Name: SCH-U940(CDMA), E-Field, Slide Close Date:2008/11/25**

**Procedure Name: Ch.0384, Ant, Intenna, Bat. Standard(RC3/SO55)**

Communication System: CDMA(HAC); Frequency: 836.52 MHz;Duty Cycle: 1:1

Medium parameters used:  $\sigma = 0$  mho/m,  $\epsilon_r = 1$ ;  $\rho = 1$  kg/m<sup>3</sup>

Phantom section: E Device Section

DASY4 Configuration:

- Probe: ER3DV6 - SN2370; ConvF(1, 1, 1); Calibrated: 2008-04-21

- Sensor-Surface: (Fix Surface)

- Electronics: DAE4 Sn724; Calibrated: 2008-02-28

- Phantom: HAC Test Arch with Coil; Type: SD HAC P01 BA; Serial: 1018

- Measurement SW: DASY4, V4.7 Build 71; Postprocessing SW: SEMCAD, V1.8 Build 184

### **Ch.0384, Ant, Intenna, Bat. Standard(RC3/SO55)/Hearing Aid Compatibility Test**

**(101x101x1):** Measurement grid: dx=5mm, dy=5mm

Maximum value of peak Total field = 70.5 V/m

Probe Modulation Factor = 1.01

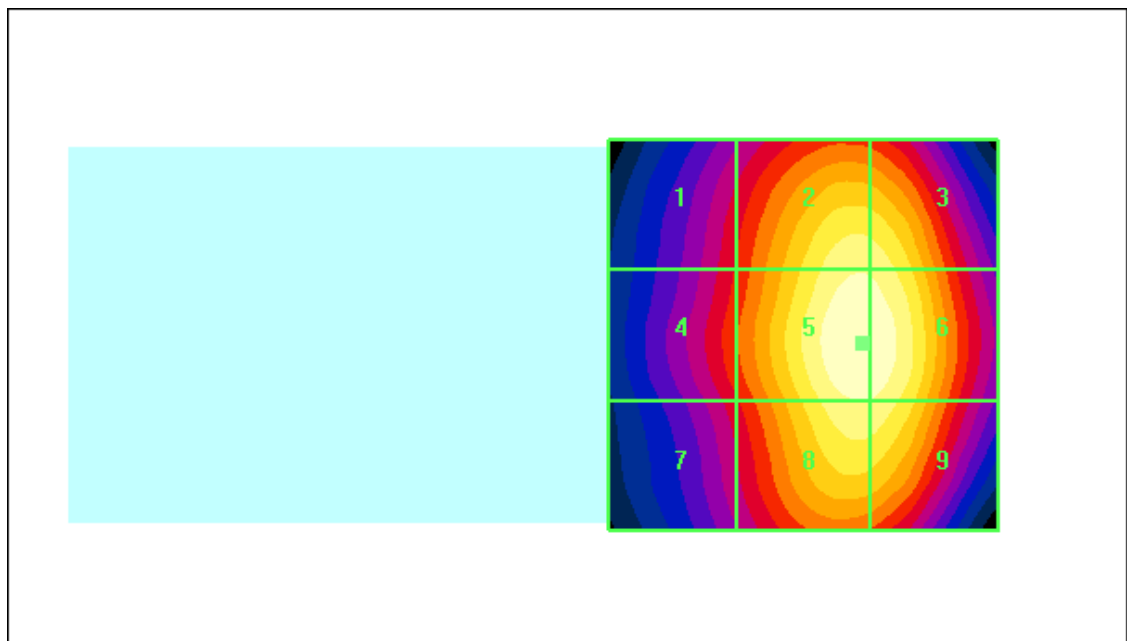
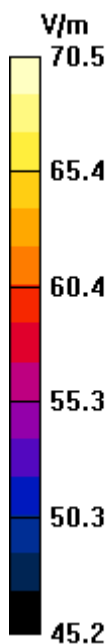
Device Reference Point: 0.000, 0.000, 353.7 mm

Reference Value = 85.4 V/m; Power Drift = 0.069 dB

**Hearing Aid Near-Field Category: M4 (AWF 0 dB)**

Peak E-field in V/m

Grid 1 <b>59.0 M4</b>	Grid 2 <b>68.7 M4</b>	Grid 3 <b>68.6 M4</b>
Grid 4 <b>60.3 M4</b>	Grid 5 <b>70.5 M4</b>	Grid 6 <b>70.4 M4</b>
Grid 7 <b>58.5 M4</b>	Grid 8 <b>68.9 M4</b>	Grid 9 <b>68.8 M4</b>



**DUT: SCH-U940; Serial: AF-102-A**

**Program Name: SCH-U940(CDMA), E-Field, Slide Close Date:2008/11/24**

**Procedure Name: Ch.0777, Ant, Intenna, Bat. Standard(RC3/SO55)**

Communication System: CDMA(HAC); Frequency: 848.31 MHz;Duty Cycle: 1:1

Medium parameters used:  $\sigma = 0$  mho/m,  $\epsilon_r = 1$ ;  $\rho = 1$  kg/m<sup>3</sup>

Phantom section: E Device Section

DASY4 Configuration:

- Probe: ER3DV6 - SN2370; ConvF(1, 1, 1); Calibrated: 2008-04-21

- Sensor-Surface: (Fix Surface)

- Electronics: DAE4 Sn724; Calibrated: 2008-02-28

- Phantom: HAC Test Arch with Coil; Type: SD HAC P01 BA; Serial: 1018

- Measurement SW: DASY4, V4.7 Build 71; Postprocessing SW: SEMCAD, V1.8 Build 184

### **Ch.0777, Ant, Intenna, Bat. Standard(RC3/SO55)/Hearing Aid Compatibility Test**

**(101x101x1):** Measurement grid: dx=5mm, dy=5mm

Maximum value of peak Total field = 75.0 V/m

Probe Modulation Factor = 1.01

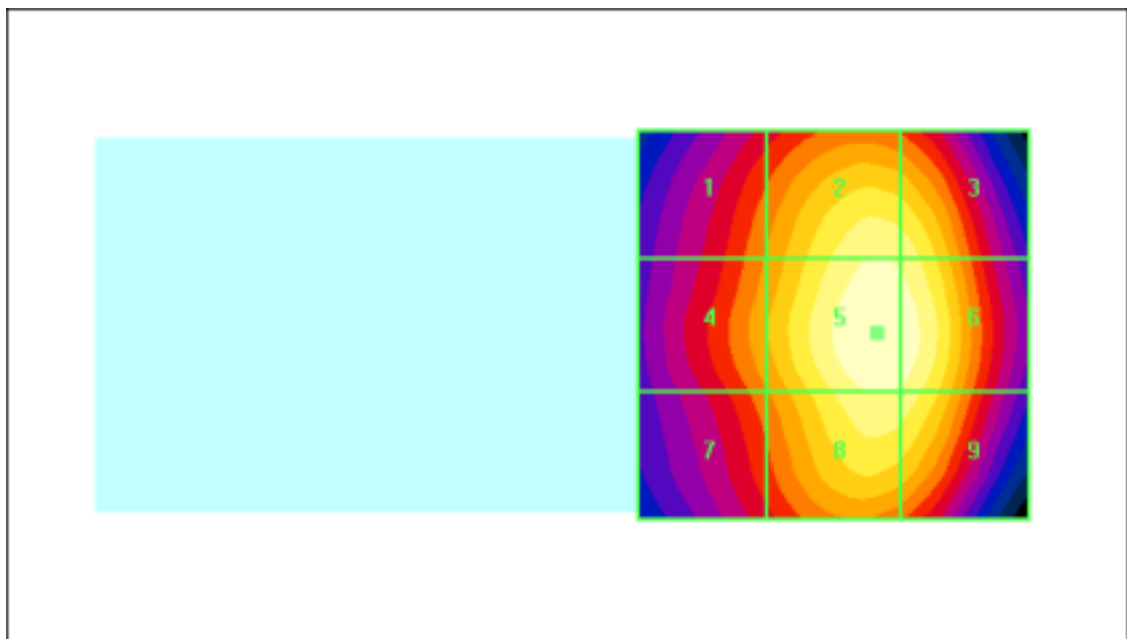
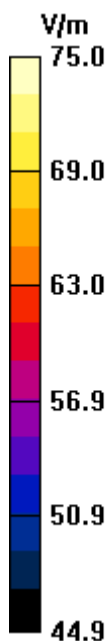
Device Reference Point: 0.000, 0.000, 353.7 mm

Reference Value = 93.6 V/m; Power Drift = 0.062 dB

**Hearing Aid Near-Field Category: M4 (AWF 0 dB)**

Peak E-field in V/m

Grid 1 <b>65.3 M4</b>	Grid 2 <b>73.0 M4</b>	Grid 3 <b>72.6 M4</b>
Grid 4 <b>66.8 M4</b>	Grid 5 <b>75.0 M4</b>	Grid 6 <b>74.6 M4</b>
Grid 7 <b>64.8 M4</b>	Grid 8 <b>73.2 M4</b>	Grid 9 <b>72.8 M4</b>



**DUT: SCH-U940; Serial: AF-102-A**

**Program Name: SCH-U940(PCS), E-Field, Slide Close, Date:2008/11/25**

**Procedure Name: Ch.25, Ant, Intenna, Bat. Standard(RC3/SO55)**

Communication System: PCS; Frequency: 1851.25 MHz;Duty Cycle: 1:1

Medium parameters used:  $\sigma = 0$  mho/m,  $\epsilon_r = 1$ ;  $\rho = 1$  kg/m<sup>3</sup>

Phantom section: E Device Section

DASY4 Configuration:

- Probe: ER3DV6 - SN2370; ConvF(1, 1, 1); Calibrated: 2008-04-21

- Sensor-Surface: (Fix Surface)

- Electronics: DAE4 Sn724; Calibrated: 2008-02-28

- Phantom: HAC Test Arch with Coil; Type: SD HAC P01 BA; Serial: 1018

- Measurement SW: DASY4, V4.7 Build 71; Postprocessing SW: SEMCAD, V1.8 Build 184

### **Ch.25, Ant, Intenna, Bat. Standard(RC3/SO55)/Hearing Aid Compatibility Test**

**(101x101x1):** Measurement grid: dx=5mm, dy=5mm

Maximum value of peak Total field = 43.3 V/m

Probe Modulation Factor = 0.980

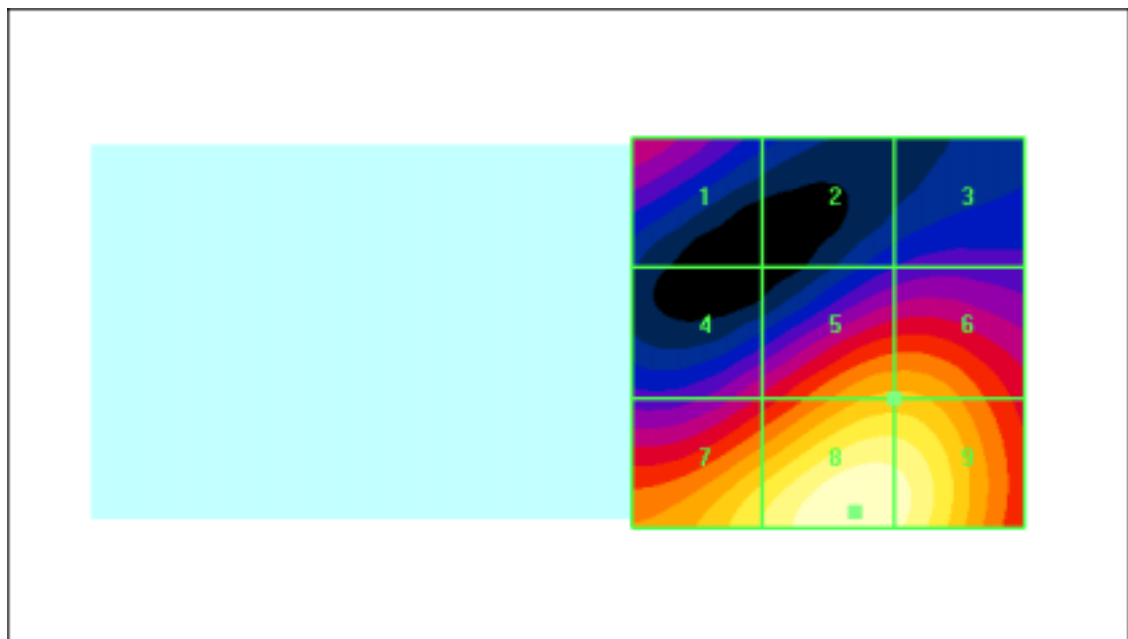
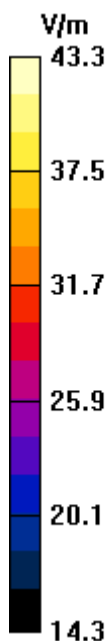
Device Reference Point: 0.000, 0.000, 353.7 mm

Reference Value = 33.4 V/m; Power Drift = -0.011 dB

**Hearing Aid Near-Field Category: M4 (AWF 0 dB)**

Peak E-field in V/m

Grid 1 <b>27.9 M4</b>	Grid 2 <b>22.1 M4</b>	Grid 3 <b>23.3 M4</b>
Grid 4 <b>28.3 M4</b>	Grid 5 <b>36.3 M4</b>	Grid 6 <b>36.3 M4</b>
Grid 7 <b>39.6 M4</b>	Grid 8 <b>43.3 M4</b>	Grid 9 <b>42.3 M4</b>



**DUT: SCH-U940; Serial: AF-102-A**

**Program Name: SCH-U940(PCS), E-Field, Slide Close, Date:2008/11/25**

**Procedure Name: Ch.600, Ant, Intenna, Bat. Standard(RC3/SO55)**

Communication System: PCS; Frequency: 1880 MHz;Duty Cycle: 1:1

Medium parameters used:  $\sigma = 0$  mho/m,  $\epsilon_r = 1$ ;  $\rho = 1$  kg/m<sup>3</sup>

Phantom section: E Device Section

DASY4 Configuration:

- Probe: ER3DV6 - SN2370; ConvF(1, 1, 1); Calibrated: 2008-04-21

- Sensor-Surface: (Fix Surface)

- Electronics: DAE4 Sn724; Calibrated: 2008-02-28

- Phantom: HAC Test Arch with Coil; Type: SD HAC P01 BA; Serial: 1018

- Measurement SW: DASY4, V4.7 Build 71; Postprocessing SW: SEMCAD, V1.8 Build 184

### **Ch.600, Ant, Intenna, Bat. Standard(RC3/SO55)/Hearing Aid Compatibility Test**

**(101x101x1):** Measurement grid: dx=5mm, dy=5mm

Maximum value of peak Total field = 42.2 V/m

Probe Modulation Factor = 0.980

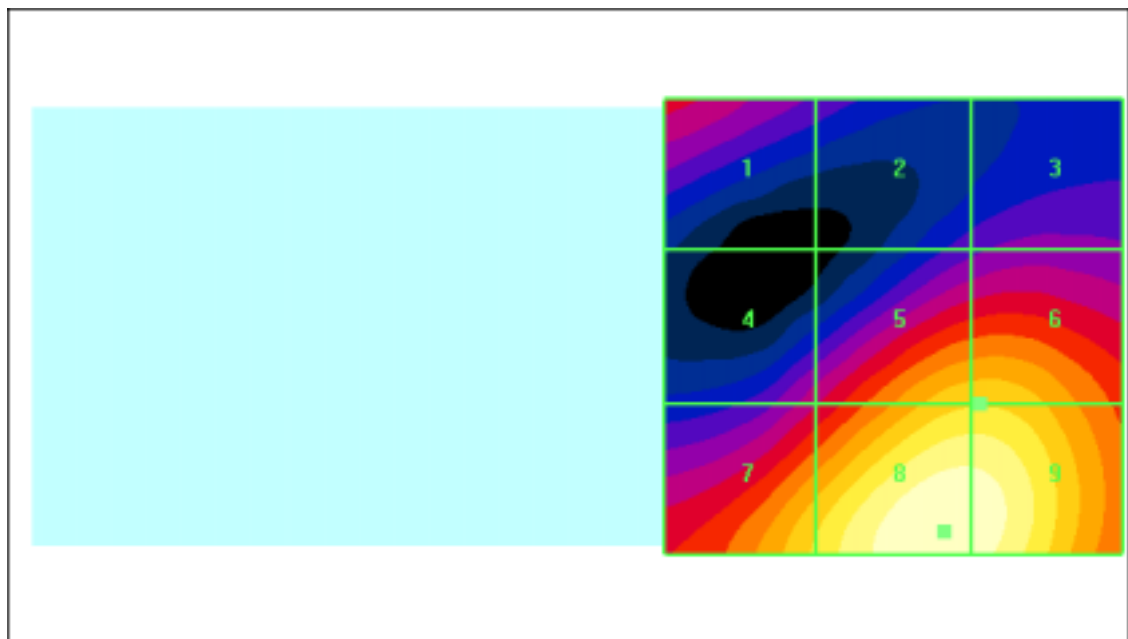
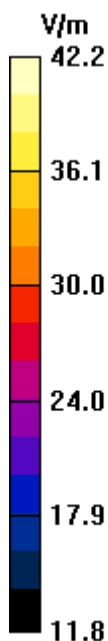
Device Reference Point: 0.000, 0.000, 353.7 mm

Reference Value = 32.0 V/m; Power Drift = 0.038 dB

**Hearing Aid Near-Field Category: M4 (AWF 0 dB)**

Peak E-field in V/m

Grid 1 <b>26.9 M4</b>	Grid 2 <b>21.7 M4</b>	Grid 3 <b>22.9 M4</b>
Grid 4 <b>25.8 M4</b>	Grid 5 <b>35.9 M4</b>	Grid 6 <b>36.0 M4</b>
Grid 7 <b>36.5 M4</b>	Grid 8 <b>42.2 M4</b>	Grid 9 <b>41.8 M4</b>



**DUT: SCH-U940; Serial: AF-102-A**

**Program Name: SCH-U940(PCS), E-Field, Slide Close, Date:2008/11/25**

**Procedure Name: Ch.1175, Ant, Intenna, Bat. Standard(RC3/SO55)**

Communication System: PCS; Frequency: 1908.75 MHz;Duty Cycle: 1:1

Medium parameters used:  $\sigma = 0$  mho/m,  $\epsilon_r = 1$ ;  $\rho = 1$  kg/m<sup>3</sup>

Phantom section: E Device Section

DASY4 Configuration:

- Probe: ER3DV6 - SN2370; ConvF(1, 1, 1); Calibrated: 2008-04-21

- Sensor-Surface: (Fix Surface)

- Electronics: DAE4 Sn724; Calibrated: 2008-02-28

- Phantom: HAC Test Arch with Coil; Type: SD HAC P01 BA; Serial: 1018

- Measurement SW: DASY4, V4.7 Build 71; Postprocessing SW: SEMCAD, V1.8 Build 184

**Ch.1175, Ant, Intenna, Bat. Standard(RC3/SO55)/Hearing Aid Compatibility Test**

**(101x101x1):** Measurement grid: dx=5mm, dy=5mm

Maximum value of peak Total field = 39.8 V/m

Probe Modulation Factor = 0.980

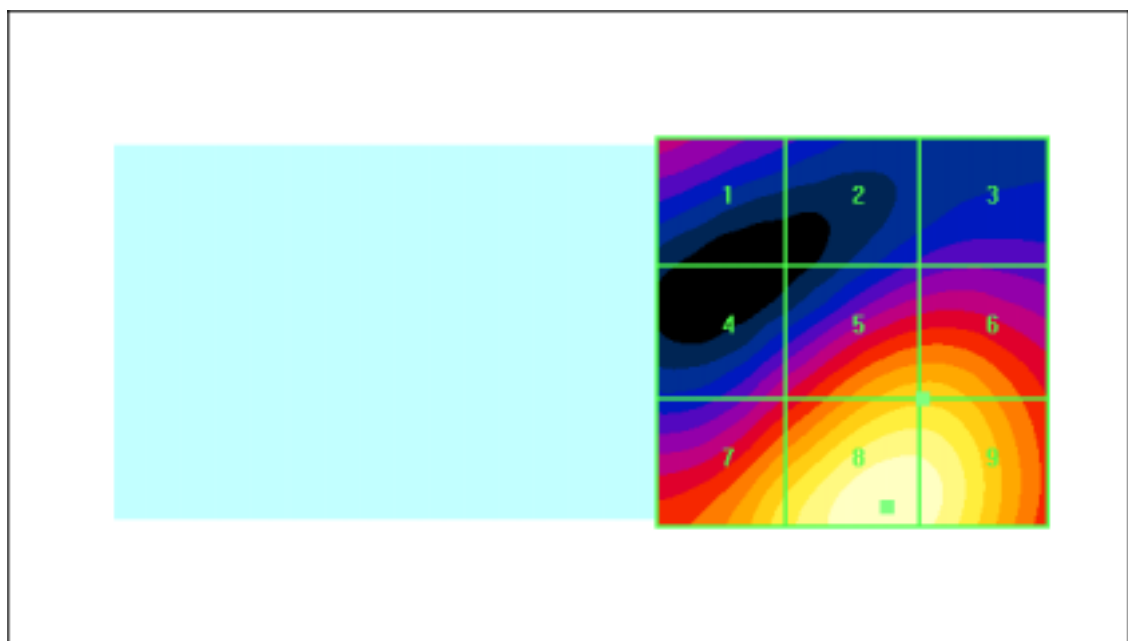
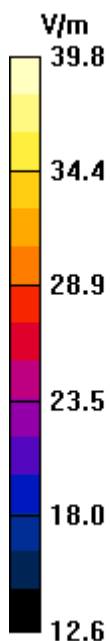
Device Reference Point: 0.000, 0.000, 353.7 mm

Reference Value = 29.9 V/m; Power Drift = 0.069 dB

**Hearing Aid Near-Field Category: M4 (AWF 0 dB)**

Peak E-field in V/m

Grid 1 <b>24.4 M4</b>	Grid 2 <b>20.5 M4</b>	Grid 3 <b>21.6 M4</b>
Grid 4 <b>25.6 M4</b>	Grid 5 <b>33.9 M4</b>	Grid 6 <b>33.9 M4</b>
Grid 7 <b>35.6 M4</b>	Grid 8 <b>39.8 M4</b>	Grid 9 <b>39.2 M4</b>



**DUT: SCH-U940; Serial: AF-102-A**

**Program Name: SCH-U940(PCS), E-Field, Slide Close, Date:2008/11/25**

**Procedure Name: Ch.25, Ant, Intenna, Bat. Standard(RC3/SO55) BackLight ON**

Communication System: PCS; Frequency: 1851.25 MHz;Duty Cycle: 1:1

Medium parameters used:  $\sigma = 0$  mho/m,  $\epsilon_r = 1$ ;  $\rho = 1$  kg/m<sup>3</sup>

Phantom section: E Device Section

DASY4 Configuration:

- Probe: ER3DV6 - SN2370; ConvF(1, 1, 1); Calibrated: 2008-04-21

- Sensor-Surface: (Fix Surface)

- Electronics: DAE4 Sn724; Calibrated: 2008-02-28

- Phantom: HAC Test Arch with Coil; Type: SD HAC P01 BA; Serial: 1018

- Measurement SW: DASY4, V4.7 Build 71; Postprocessing SW: SEMCAD, V1.8 Build 184

**Ch.25, Ant, Intenna, Bat. Standard(RC3/SO55) BackLight ON/Hearing Aid Compatibility**

**Test (101x101x1):** Measurement grid: dx=5mm, dy=5mm

Maximum value of peak Total field = 43.0 V/m

Probe Modulation Factor = 0.980

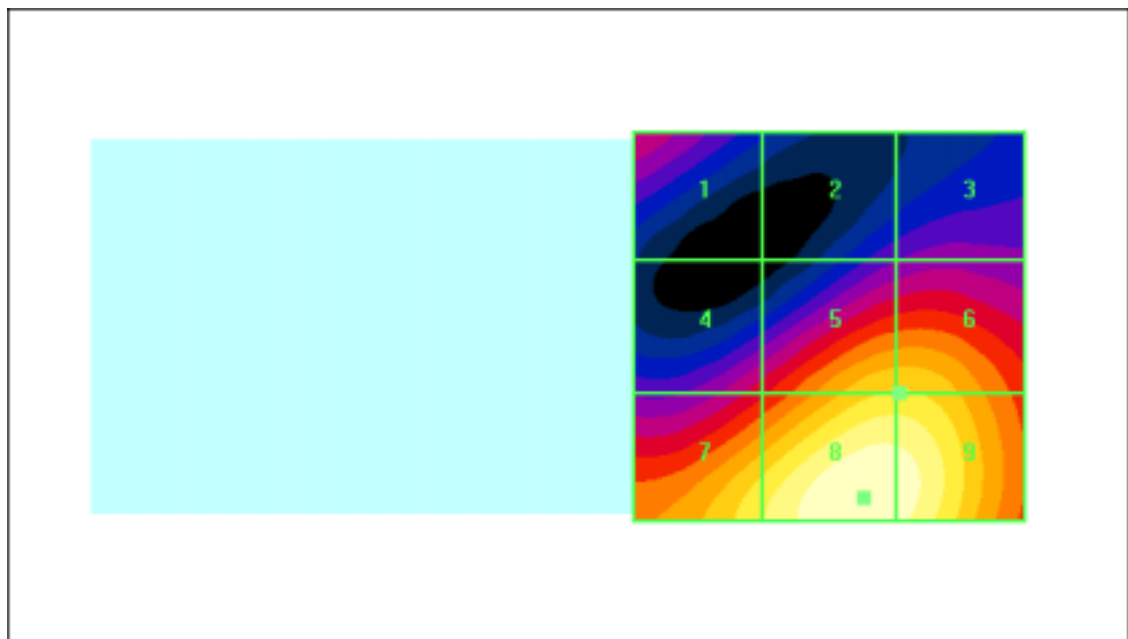
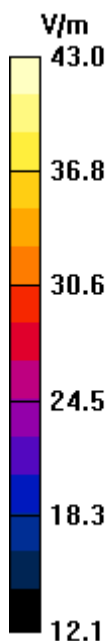
Device Reference Point: 0.000, 0.000, 353.7 mm

Reference Value = 33.7 V/m; Power Drift = 0.021 dB

**Hearing Aid Near-Field Category: M4 (AWF 0 dB)**

Peak E-field in V/m

Grid 1 <b>26.8 M4</b>	Grid 2 <b>22.4 M4</b>	Grid 3 <b>23.9 M4</b>
Grid 4 <b>28.1 M4</b>	Grid 5 <b>37.1 M4</b>	Grid 6 <b>37.1 M4</b>
Grid 7 <b>38.8 M4</b>	Grid 8 <b>43.0 M4</b>	Grid 9 <b>42.4 M4</b>



**DUT: SCH-U940; Serial: AF-102-A**

**Program Name: SCH-U940(PCS), E-Field, Slide Close, Date:2008/11/25**

**Procedure Name: Ch.25, Ant, Intenna, Bat. Extended(RC3/SO55)**

Communication System: PCS; Frequency: 1851.25 MHz;Duty Cycle: 1:1

Medium parameters used:  $\sigma = 0$  mho/m,  $\epsilon_r = 1$ ;  $\rho = 1$  kg/m<sup>3</sup>

Phantom section: E Device Section

DASY4 Configuration:

- Probe: ER3DV6 - SN2370; ConvF(1, 1, 1); Calibrated: 2008-04-21

- Sensor-Surface: (Fix Surface)

- Electronics: DAE4 Sn724; Calibrated: 2008-02-28

- Phantom: HAC Test Arch with Coil; Type: SD HAC P01 BA; Serial: 1018

- Measurement SW: DASY4, V4.7 Build 71; Postprocessing SW: SEMCAD, V1.8 Build 184

### **Ch.25, Ant, Intenna, Bat. Extended(RC3/SO55)/Hearing Aid Compatibility Test**

**(101x101x1):** Measurement grid: dx=5mm, dy=5mm

Maximum value of peak Total field = 40.5 V/m

Probe Modulation Factor = 0.980

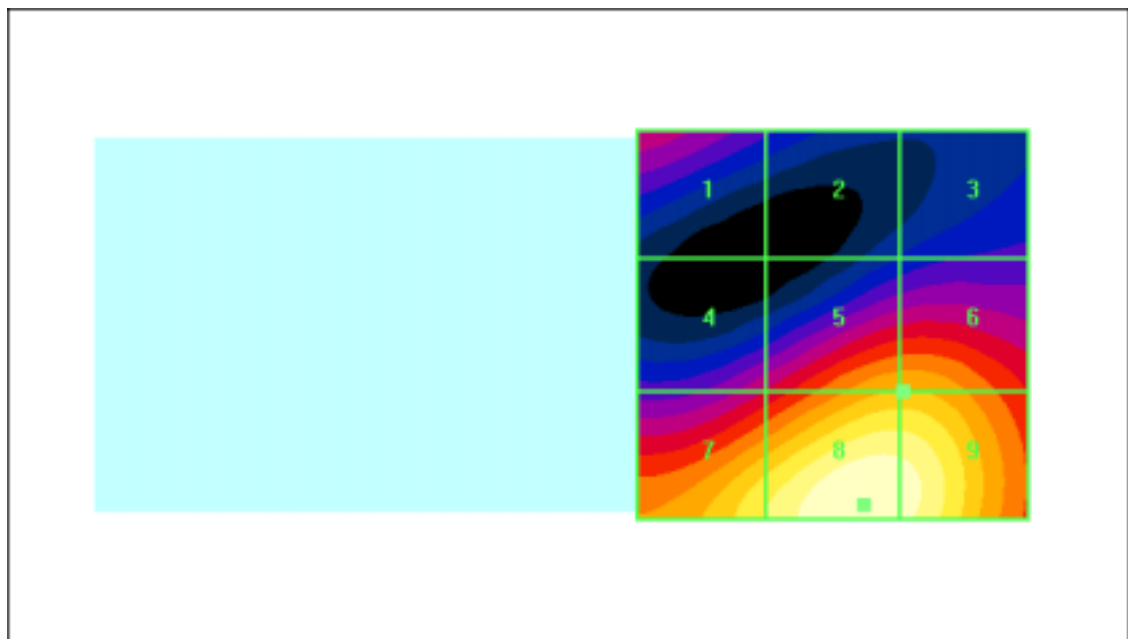
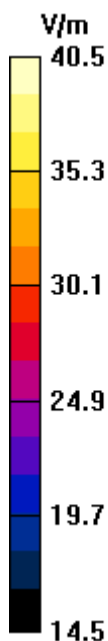
Device Reference Point: 0.000, 0.000, 353.7 mm

Reference Value = 29.5 V/m; Power Drift = -0.188 dB

**Hearing Aid Near-Field Category: M4 (AWF 0 dB)**

Peak E-field in V/m

Grid 1 <b>26.3 M4</b>	Grid 2 <b>22.0 M4</b>	Grid 3 <b>22.1 M4</b>
Grid 4 <b>26.8 M4</b>	Grid 5 <b>33.8 M4</b>	Grid 6 <b>33.8 M4</b>
Grid 7 <b>37.1 M4</b>	Grid 8 <b>40.5 M4</b>	Grid 9 <b>39.9 M4</b>



**DUT: SCH-U940; Serial: AF-102-A**

**Program Name: SCH-U940(CDMA), E-Field, Slide Open Date: 2008/11/25**

**Procedure Name: Ch.1013, Ant, Intenna, Bat. Standard(RC3/SO55)**

Communication System: CDMA(HAC); Frequency: 824.7 MHz; Duty Cycle: 1:1

Medium parameters used:  $\sigma = 0$  mho/m,  $\epsilon_r = 1$ ;  $\rho = 1$  kg/m<sup>3</sup>

Phantom section: E Device Section

DASY4 Configuration:

- Probe: ER3DV6 - SN2370; ConvF(1, 1, 1); Calibrated: 2008-04-21

- Sensor-Surface: (Fix Surface)

- Electronics: DAE4 Sn724; Calibrated: 2008-02-28

- Phantom: HAC Test Arch with Coil; Type: SD HAC P01 BA; Serial: 1018

- Measurement SW: DASY4, V4.7 Build 71; Postprocessing SW: SEMCAD, V1.8 Build 184

### **Ch.1013, Ant, Intenna, Bat. Standard(RC3/SO55)/Hearing Aid Compatibility Test**

**(101x101x1):** Measurement grid: dx=5mm, dy=5mm

Maximum value of peak Total field = 38.1 V/m

Probe Modulation Factor = 1.01

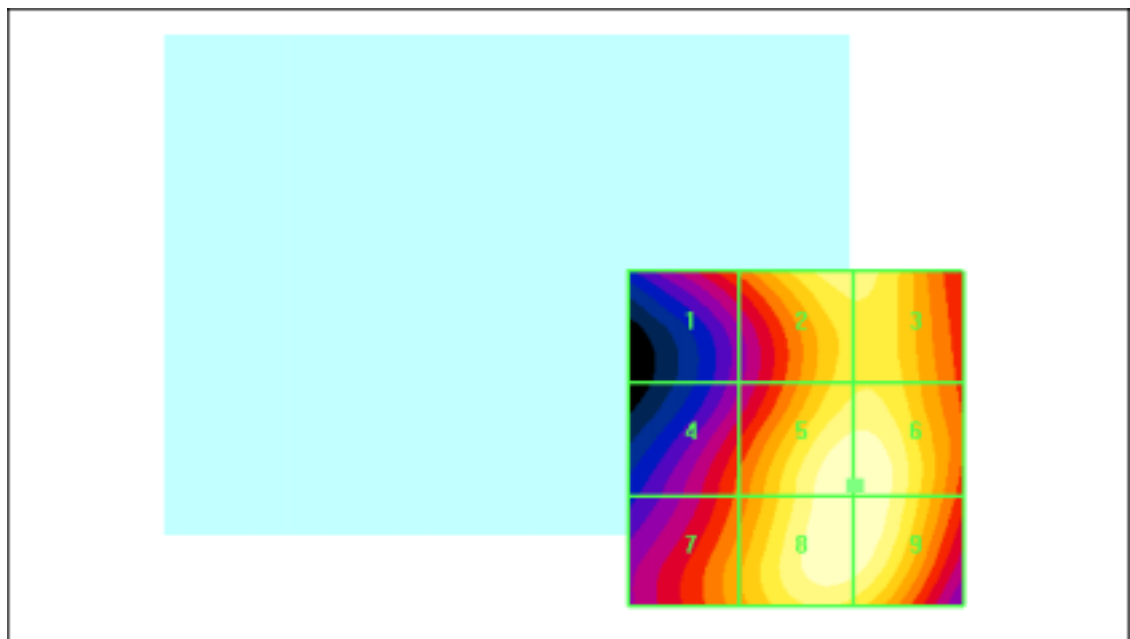
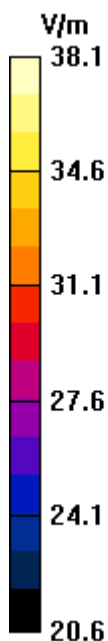
Device Reference Point: 0.000, 0.000, 353.7 mm

Reference Value = 41.8 V/m; Power Drift = -0.160 dB

**Hearing Aid Near-Field Category: M4 (AWF 0 dB)**

Peak E-field in V/m

Grid 1	Grid 2	Grid 3
<b>31.5 M4</b>	<b>36.5 M4</b>	<b>36.5 M4</b>
Grid 4	Grid 5	Grid 6
<b>31.5 M4</b>	<b>38.1 M4</b>	<b>38.1 M4</b>
Grid 7	Grid 8	Grid 9
<b>33.2 M4</b>	<b>38.1 M4</b>	<b>38.1 M4</b>



**DUT: SCH-U940; Serial: AF-102-A**

**Program Name: SCH-U940(CDMA), E-Field, Slide Open Date: 2008/11/25**

**Procedure Name: Ch.0384, Ant, Intenna, Bat. Standard(RC3/SO55)**

Communication System: CDMA(HAC); Frequency: 836.52 MHz; Duty Cycle: 1:1

Medium parameters used:  $\sigma = 0$  mho/m,  $\epsilon_r = 1$ ;  $\rho = 1$  kg/m<sup>3</sup>

Phantom section: E Device Section

DASY4 Configuration:

- Probe: ER3DV6 - SN2370; ConvF(1, 1, 1); Calibrated: 2008-04-21

- Sensor-Surface: (Fix Surface)

- Electronics: DAE4 Sn724; Calibrated: 2008-02-28

- Phantom: HAC Test Arch with Coil; Type: SD HAC P01 BA; Serial: 1018

- Measurement SW: DASY4, V4.7 Build 71; Postprocessing SW: SEMCAD, V1.8 Build 184

### **Ch.0384, Ant, Intenna, Bat. Standard(RC3/SO55)/Hearing Aid Compatibility Test**

**(101x101x1):** Measurement grid: dx=5mm, dy=5mm

Maximum value of peak Total field = 47.6 V/m

Probe Modulation Factor = 1.01

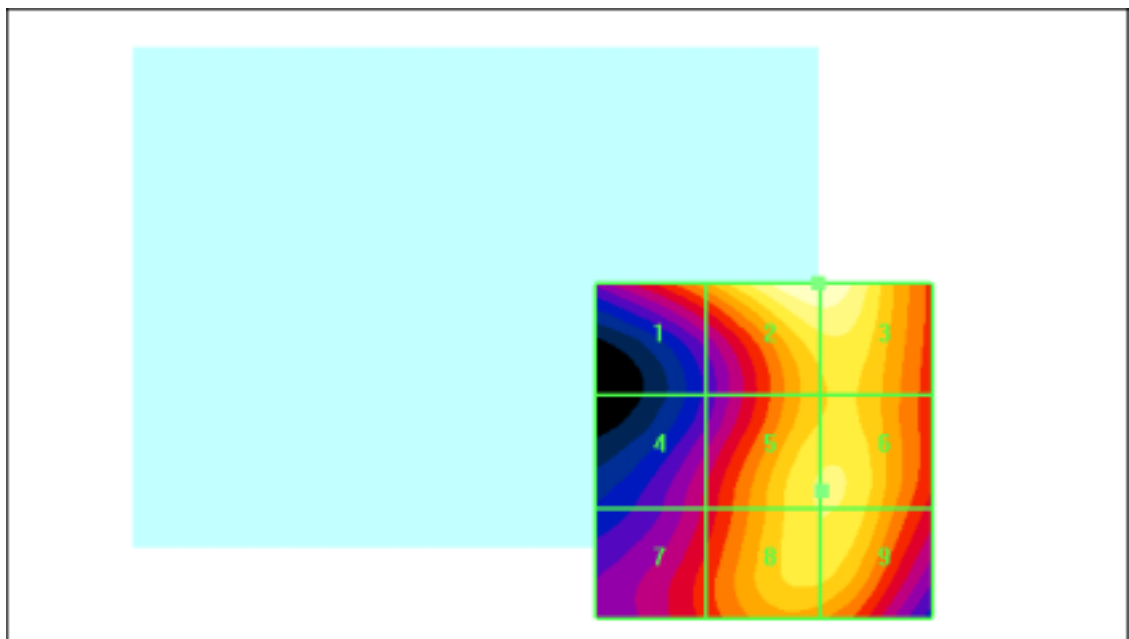
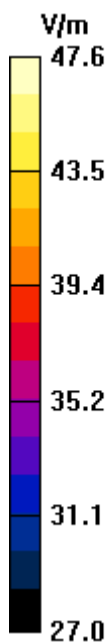
Device Reference Point: 0.000, 0.000, 353.7 mm

Reference Value = 48.6 V/m; Power Drift = -0.016 dB

**Hearing Aid Near-Field Category: M4 (AWF 0 dB)**

Peak E-field in V/m

Grid 1 <b>41.9 M4</b>	Grid 2 <b>47.6 M4</b>	Grid 3 <b>47.6 M4</b>
Grid 4 <b>37.1 M4</b>	Grid 5 <b>45.1 M4</b>	Grid 6 <b>45.1 M4</b>
Grid 7 <b>38.8 M4</b>	Grid 8 <b>44.9 M4</b>	Grid 9 <b>45.0 M4</b>



**DUT: SCH-U940; Serial: AF-102-A**

**Program Name: SCH-U940(CDMA), E-Field, Slide Open Date: 2008/11/25**

**Procedure Name: Ch.0777, Ant, Intenna, Bat. Standard(RC3/SO55)**

Communication System: CDMA(HAC); Frequency: 848.31 MHz; Duty Cycle: 1:1

Medium parameters used:  $\sigma = 0$  mho/m,  $\epsilon_r = 1$ ;  $\rho = 1$  kg/m<sup>3</sup>

Phantom section: E Device Section

DASY4 Configuration:

- Probe: ER3DV6 - SN2370; ConvF(1, 1, 1); Calibrated: 2008-04-21

- Sensor-Surface: (Fix Surface)

- Electronics: DAE4 Sn724; Calibrated: 2008-02-28

- Phantom: HAC Test Arch with Coil; Type: SD HAC P01 BA; Serial: 1018

- Measurement SW: DASY4, V4.7 Build 71; Postprocessing SW: SEMCAD, V1.8 Build 184

**Ch.0777, Ant, Intenna, Bat. Standard(RC3/SO55)/Hearing Aid Compatibility Test**

**(101x101x1):** Measurement grid: dx=5mm, dy=5mm

Maximum value of peak Total field = 47.4 V/m

Probe Modulation Factor = 1.01

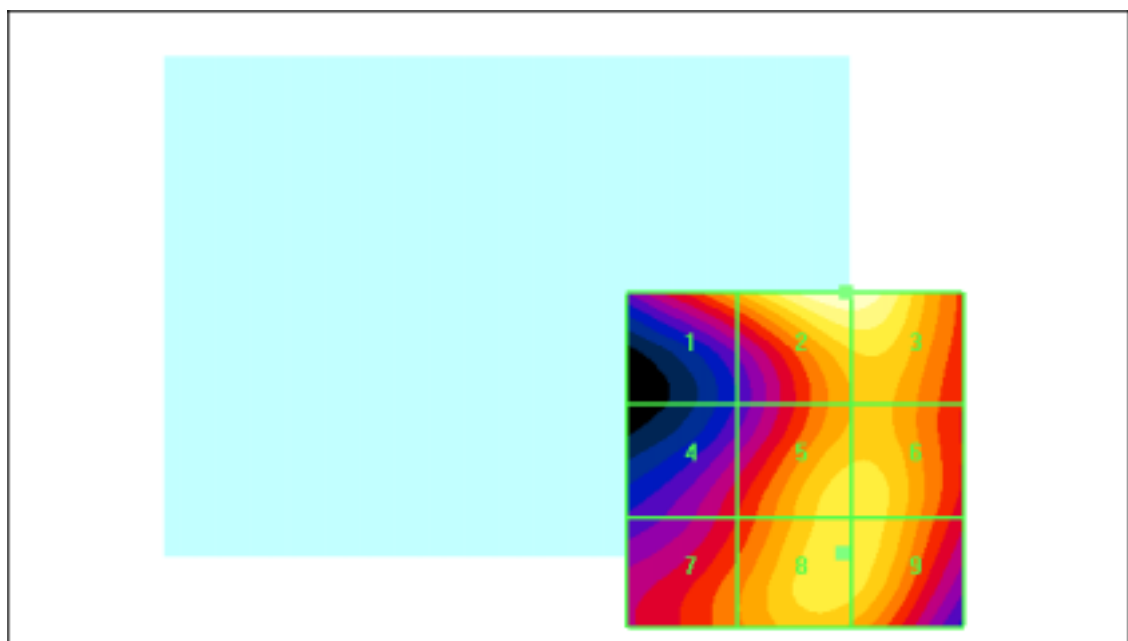
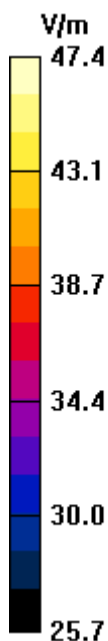
Device Reference Point: 0.000, 0.000, 353.7 mm

Reference Value = 46.9 V/m; Power Drift = 0.081 dB

**Hearing Aid Near-Field Category: M4 (AWF 0 dB)**

Peak E-field in V/m

Grid 1 <b>41.8 M4</b>	Grid 2 <b>47.4 M4</b>	Grid 3 <b>47.3 M4</b>
Grid 4 <b>37.3 M4</b>	Grid 5 <b>44.1 M4</b>	Grid 6 <b>44.1 M4</b>
Grid 7 <b>40.1 M4</b>	Grid 8 <b>44.2 M4</b>	Grid 9 <b>44.2 M4</b>



**DUT: SCH-U940; Serial: AF-102-A**

**Program Name: SCH-U940(PCS), E-Field,Slide Open, Date:2008/11/25**

**Procedure Name: Ch.25, Ant, Intenna, Bat. Standard(RC3/SO55)**

Communication System: PCS; Frequency: 1851.25 MHz;Duty Cycle: 1:1

Medium parameters used:  $\sigma = 0$  mho/m,  $\epsilon_r = 1$ ;  $\rho = 1$  kg/m<sup>3</sup>

Phantom section: E Device Section

DASY4 Configuration:

- Probe: ER3DV6 - SN2370; ConvF(1, 1, 1); Calibrated: 2008-04-21

- Sensor-Surface: (Fix Surface)

- Electronics: DAE4 Sn724; Calibrated: 2008-02-28

- Phantom: HAC Test Arch with Coil; Type: SD HAC P01 BA; Serial: 1018

- Measurement SW: DASY4, V4.7 Build 71; Postprocessing SW: SEMCAD, V1.8 Build 184

### **Ch.25, Ant, Intenna, Bat. Standard(RC3/SO55)/Hearing Aid Compatibility Test**

**(101x101x1):** Measurement grid: dx=5mm, dy=5mm

Maximum value of peak Total field = 42.4 V/m

Probe Modulation Factor = 0.980

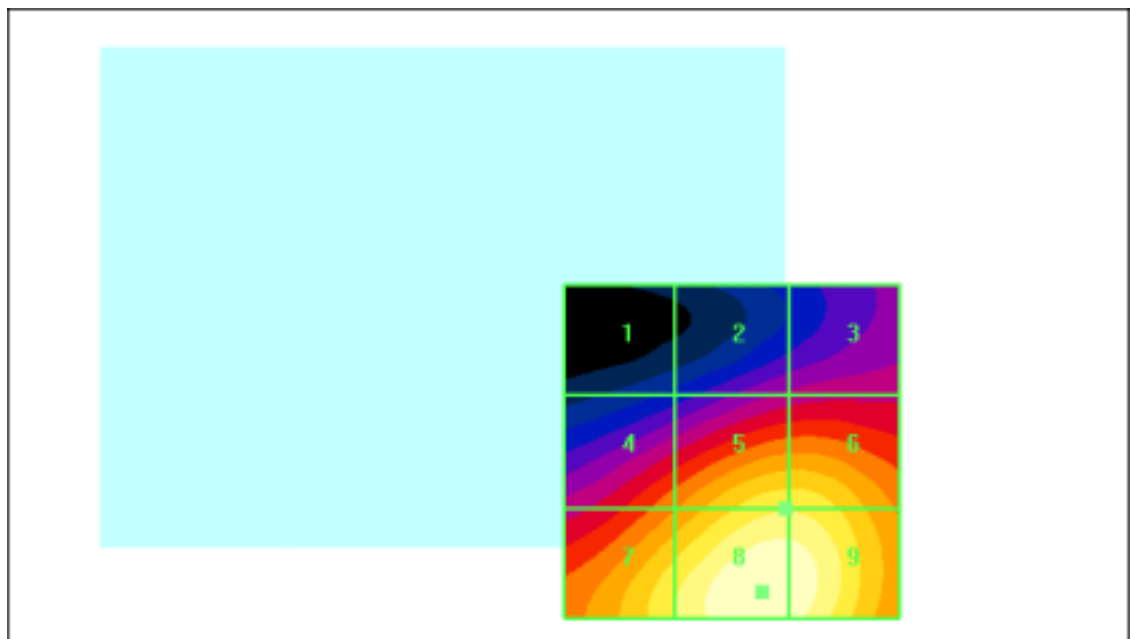
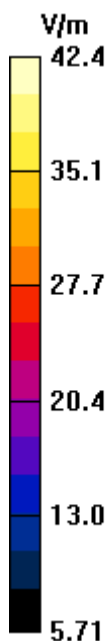
Device Reference Point: 0.000, 0.000, 353.7 mm

Reference Value = 35.1 V/m; Power Drift = -0.013 dB

**Hearing Aid Near-Field Category: M4 (AWF 0 dB)**

Peak E-field in V/m

Grid 1 <b>14.1 M4</b>	Grid 2 <b>21.1 M4</b>	Grid 3 <b>22.3 M4</b>
Grid 4 <b>30.0 M4</b>	Grid 5 <b>37.2 M4</b>	Grid 6 <b>37.2 M4</b>
Grid 7 <b>37.5 M4</b>	Grid 8 <b>42.4 M4</b>	Grid 9 <b>41.9 M4</b>



**DUT: SCH-U940; Serial: AF-102-A**

**Program Name: SCH-U940(PCS), E-Field,Slide Open, Date:2008/11/25**

**Procedure Name: Ch.600, Ant, Intenna, Bat. Standard(RC3/SO55)**

Communication System: PCS; Frequency: 1880 MHz;Duty Cycle: 1:1

Medium parameters used:  $\sigma = 0$  mho/m,  $\epsilon_r = 1$ ;  $\rho = 1$  kg/m<sup>3</sup>

Phantom section: E Device Section

DASY4 Configuration:

- Probe: ER3DV6 - SN2370; ConvF(1, 1, 1); Calibrated: 2008-04-21

- Sensor-Surface: (Fix Surface)

- Electronics: DAE4 Sn724; Calibrated: 2008-02-28

- Phantom: HAC Test Arch with Coil; Type: SD HAC P01 BA; Serial: 1018

- Measurement SW: DASY4, V4.7 Build 71; Postprocessing SW: SEMCAD, V1.8 Build 184

**Ch.600, Ant, Intenna, Bat. Standard(RC3/SO55)/Hearing Aid Compatibility Test**

**(101x101x1):** Measurement grid: dx=5mm, dy=5mm

Maximum value of peak Total field = 39.4 V/m

Probe Modulation Factor = 0.980

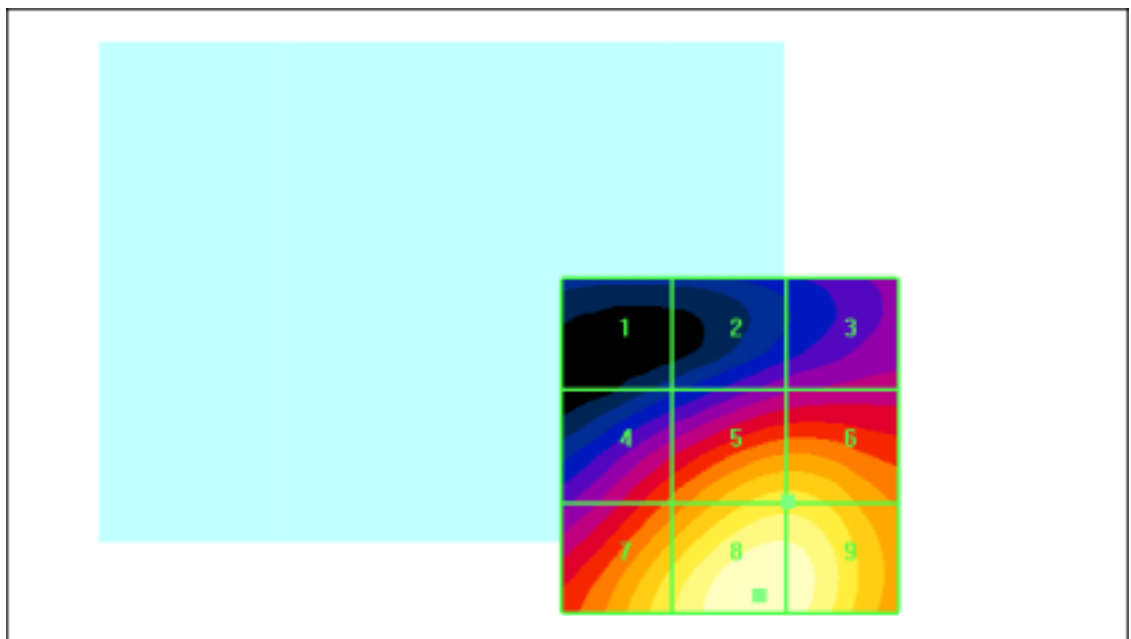
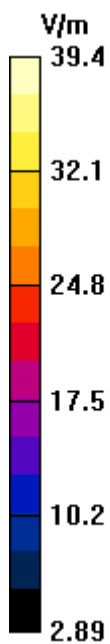
Device Reference Point: 0.000, 0.000, 353.7 mm

Reference Value = 31.1 V/m; Power Drift = 0.145 dB

**Hearing Aid Near-Field Category: M4 (AWF 0 dB)**

Peak E-field in V/m

Grid 1 <b>9.35 M4</b>	Grid 2 <b>16.8 M4</b>	Grid 3 <b>18.7 M4</b>
Grid 4 <b>25.7 M4</b>	Grid 5 <b>33.4 M4</b>	Grid 6 <b>33.4 M4</b>
Grid 7 <b>34.4 M4</b>	Grid 8 <b>39.4 M4</b>	Grid 9 <b>38.9 M4</b>



**DUT: SCH-U940; Serial: AF-102-A**

**Program Name: SCH-U940(PCS), E-Field,Slide Open, Date:2008/11/25**

**Procedure Name: Ch.1175, Ant, Intenna, Bat. Standard(RC3/SO55)**

Communication System: PCS; Frequency: 1908.75 MHz;Duty Cycle: 1:1

Medium parameters used:  $\sigma = 0$  mho/m,  $\epsilon_r = 1$ ;  $\rho = 1$  kg/m<sup>3</sup>

Phantom section: E Device Section

DASY4 Configuration:

- Probe: ER3DV6 - SN2370; ConvF(1, 1, 1); Calibrated: 2008-04-21

- Sensor-Surface: (Fix Surface)

- Electronics: DAE4 Sn724; Calibrated: 2008-02-28

- Phantom: HAC Test Arch with Coil; Type: SD HAC P01 BA; Serial: 1018

- Measurement SW: DASY4, V4.7 Build 71; Postprocessing SW: SEMCAD, V1.8 Build 184

**Ch.1175, Ant, Intenna, Bat. Standard(RC3/SO55)/Hearing Aid Compatibility Test**

**(101x101x1):** Measurement grid: dx=5mm, dy=5mm

Maximum value of peak Total field = 39.2 V/m

Probe Modulation Factor = 0.980

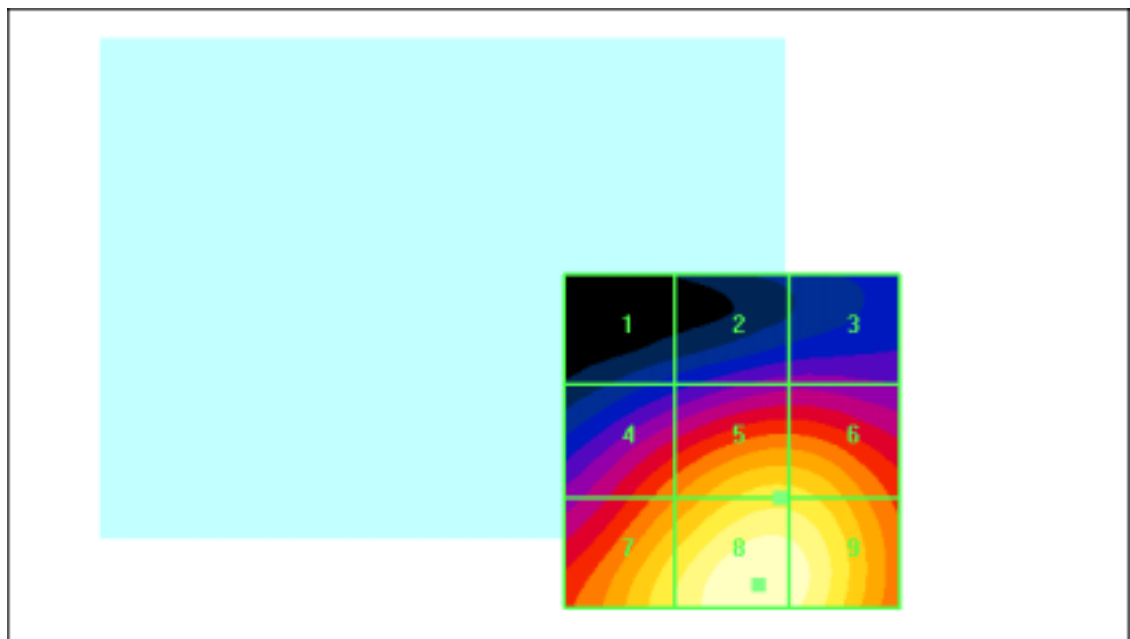
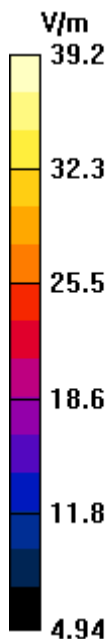
Device Reference Point: 0.000, 0.000, 353.7 mm

Reference Value = 33.6 V/m; Power Drift = -0.088 dB

**Hearing Aid Near-Field Category: M4 (AWF 0 dB)**

Peak E-field in V/m

Grid 1 <b>13.2 M4</b>	Grid 2 <b>17.8 M4</b>	Grid 3 <b>17.9 M4</b>
Grid 4 <b>27.8 M4</b>	Grid 5 <b>33.7 M4</b>	Grid 6 <b>33.6 M4</b>
Grid 7 <b>34.8 M4</b>	Grid 8 <b>39.2 M4</b>	Grid 9 <b>38.4 M4</b>



**DUT: SCH-U940; Serial: AF-102-A**

**Program Name: SCH-U940(CDMA) H-Field, Slide Close, Date: 2008/11/25**

**Procedure Name: Ch.1013, Ant, Intenna, Bat. Standard(RC3/SO55)**

Communication System: CDMA(HAC); Frequency: 824.7 MHz; Duty Cycle: 1:1

Medium parameters used:  $\sigma = 0$  mho/m,  $\epsilon_r = 1$ ;  $\rho = 1$  kg/m<sup>3</sup>

Phantom section: H Device Section

DASY4 Configuration:

- Probe: H3DV6 - SN6197; ; Calibrated: 2008-04-21

- Sensor-Surface: (Fix Surface)

- Electronics: DAE4 Sn724; Calibrated: 2008-02-28

- Phantom: HAC Test Arch with Coil; Type: SD HAC P01 BA; Serial: 1018

- Measurement SW: DASY4, V4.7 Build 71; Postprocessing SW: SEMCAD, V1.8 Build 184

### **Ch.1013, Ant, Intenna, Bat. Standard(RC3/SO55)/Hearing Aid Compatibility Test**

**(101x101x1):** Measurement grid: dx=5mm, dy=5mm

Maximum value of peak Total field = 0.126 A/m

Probe Modulation Factor = 1.02

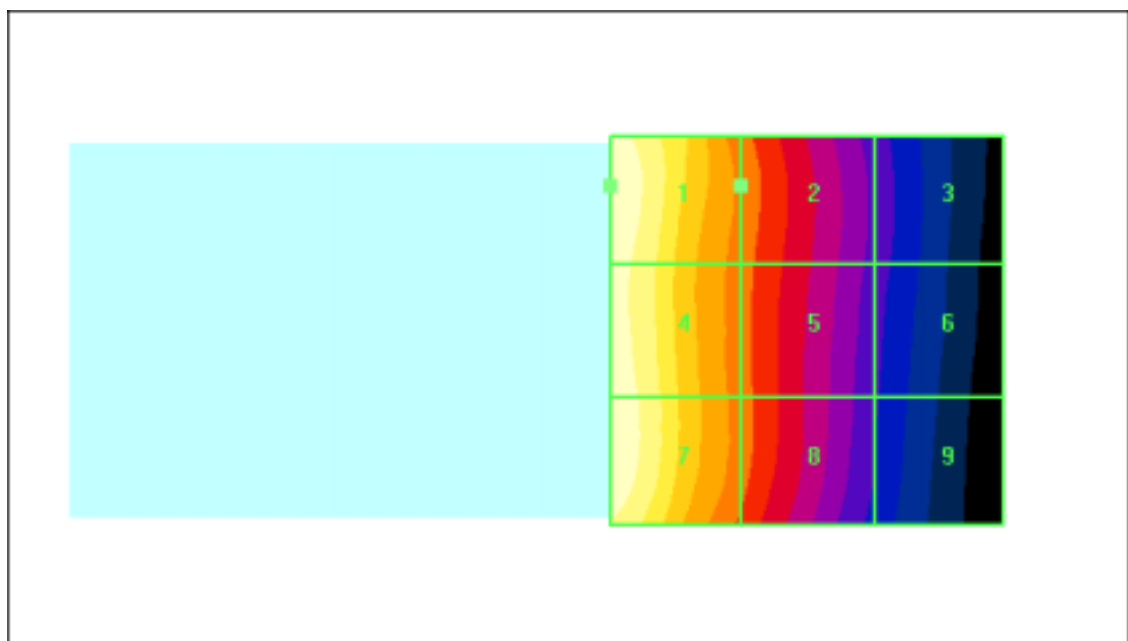
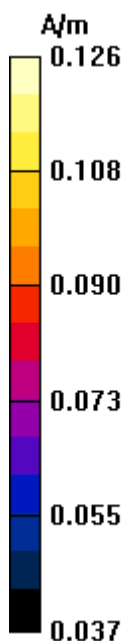
Device Reference Point: 0.000, 0.000, 353.7 mm

Reference Value = 0.084 A/m; Power Drift = -0.148 dB

**Hearing Aid Near-Field Category: M4 (AWF 0 dB)**

Peak H-field in A/m

Grid 1 <b>0.126 M4</b>	Grid 2 <b>0.095 M4</b>	Grid 3 <b>0.066 M4</b>
Grid 4 <b>0.125 M4</b>	Grid 5 <b>0.093 M4</b>	Grid 6 <b>0.065 M4</b>
Grid 7 <b>0.125 M4</b>	Grid 8 <b>0.094 M4</b>	Grid 9 <b>0.062 M4</b>



**DUT: SCH-U940; Serial: AF-102-A**

**Program Name: SCH-U940(CDMA) H-Field, Slide Close, Date: 2008/11/25**

**Procedure Name: Ch.0384, Ant, Intenna, Bat. Standard(RC3/SO55)**

Communication System: CDMA(HAC); Frequency: 836.52 MHz; Duty Cycle: 1:1

Medium parameters used:  $\sigma = 0$  mho/m,  $\epsilon_r = 1$ ;  $\rho = 1$  kg/m<sup>3</sup>

Phantom section: H Device Section

DASY4 Configuration:

- Probe: H3DV6 - SN6197; ; Calibrated: 2008-04-21

- Sensor-Surface: (Fix Surface)

- Electronics: DAE4 Sn724; Calibrated: 2008-02-28

- Phantom: HAC Test Arch with Coil; Type: SD HAC P01 BA; Serial: 1018

- Measurement SW: DASY4, V4.7 Build 71; Postprocessing SW: SEMCAD, V1.8 Build 184

### **Ch.0384, Ant, Intenna, Bat. Standard(RC3/SO55)/Hearing Aid Compatibility Test**

**(101x101x1):** Measurement grid: dx=5mm, dy=5mm

Maximum value of peak Total field = 0.135 A/m

Probe Modulation Factor = 1.02

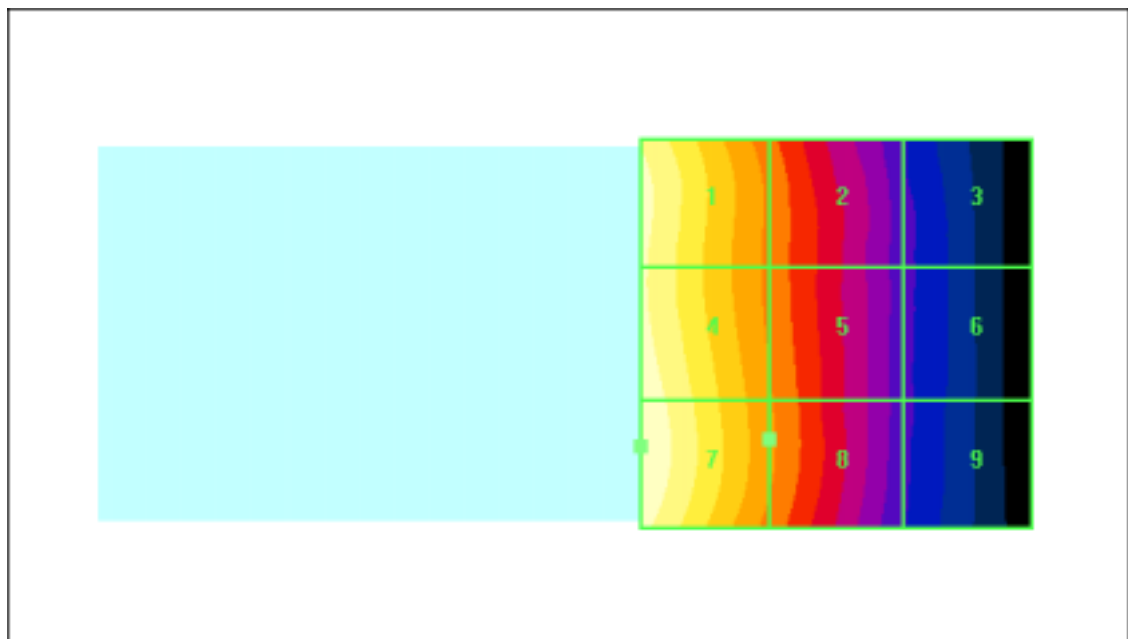
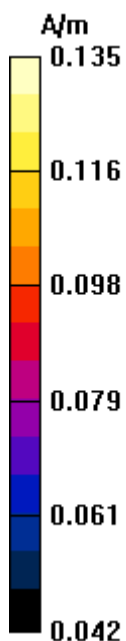
Device Reference Point: 0.000, 0.000, 353.7 mm

Reference Value = 0.091 A/m; Power Drift = 0.141 dB

**Hearing Aid Near-Field Category: M4 (AWF 0 dB)**

Peak H-field in A/m

Grid 1 <b>0.131 M4</b>	Grid 2 <b>0.103 M4</b>	Grid 3 <b>0.070 M4</b>
Grid 4 <b>0.134 M4</b>	Grid 5 <b>0.105 M4</b>	Grid 6 <b>0.070 M4</b>
Grid 7 <b>0.135 M4</b>	Grid 8 <b>0.106 M4</b>	Grid 9 <b>0.070 M4</b>



**DUT: SCH-U940; Serial: AF-102-A**

**Program Name: SCH-U940(CDMA) H-Field, Slide Close, Date: 2008/11/25**

**Procedure Name: Ch.0777, Ant, Intenna, Bat. Standard(RC3/SO55)**

Communication System: CDMA(HAC); Frequency: 848.31 MHz; Duty Cycle: 1:1

Medium parameters used:  $\sigma = 0$  mho/m,  $\epsilon_r = 1$ ;  $\rho = 1$  kg/m<sup>3</sup>

Phantom section: H Device Section

DASY4 Configuration:

- Probe: H3DV6 - SN6197; ; Calibrated: 2008-04-21

- Sensor-Surface: (Fix Surface)

- Electronics: DAE4 Sn724; Calibrated: 2008-02-28

- Phantom: HAC Test Arch with Coil; Type: SD HAC P01 BA; Serial: 1018

- Measurement SW: DASY4, V4.7 Build 71; Postprocessing SW: SEMCAD, V1.8 Build 184

### **Ch.0777, Ant, Intenna, Bat. Standard(RC3/SO55)/Hearing Aid Compatibility Test**

**(101x101x1):** Measurement grid: dx=5mm, dy=5mm

Maximum value of peak Total field = 0.163 A/m

Probe Modulation Factor = 1.02

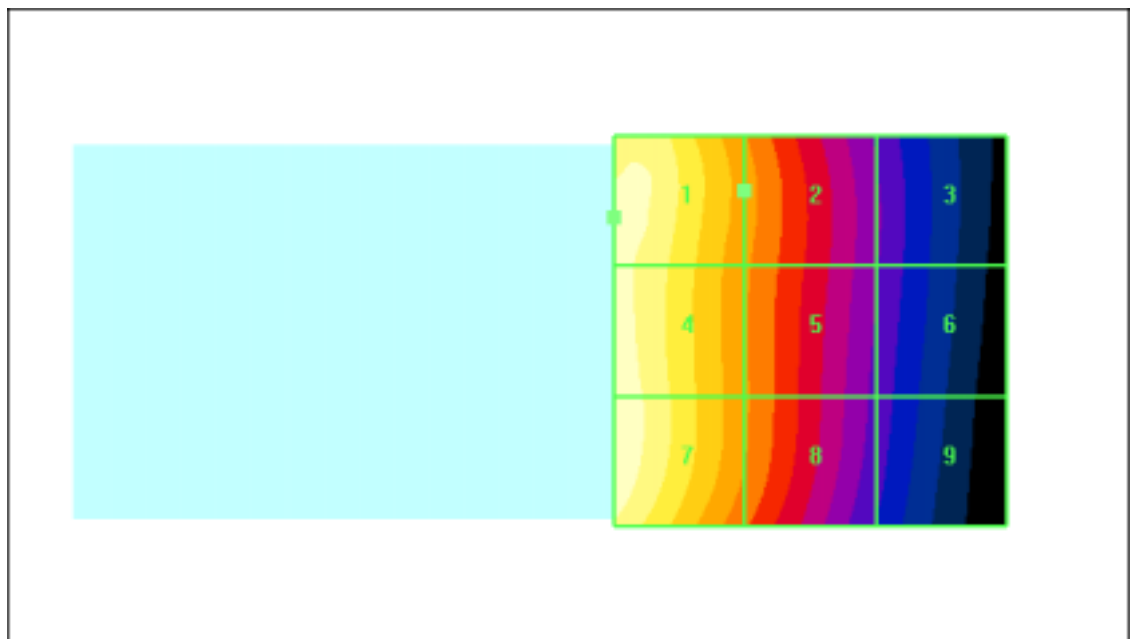
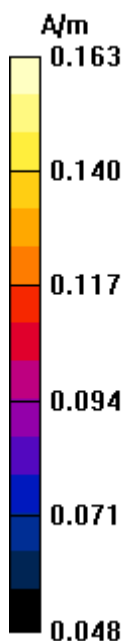
Device Reference Point: 0.000, 0.000, 353.7 mm

Reference Value = 0.107 A/m; Power Drift = 0.167 dB

**Hearing Aid Near-Field Category: M4 (AWF 0 dB)**

Peak H-field in A/m

Grid 1 <b>0.163 M4</b>	Grid 2 <b>0.129 M4</b>	Grid 3 <b>0.088 M4</b>
Grid 4 <b>0.162 M4</b>	Grid 5 <b>0.127 M4</b>	Grid 6 <b>0.087 M4</b>
Grid 7 <b>0.163 M4</b>	Grid 8 <b>0.126 M4</b>	Grid 9 <b>0.084 M4</b>



**DUT: SCH-U940; Serial: AF-102-A**

**Program Name: SCH-U940(PCS) H-Field, Slide Close, Date:2008/11/25**

**Procedure Name: Ch.0025, Ant. Intenna, Bat. Standard(RC3/SO55)**

Communication System: PCS; Frequency: 1851.25 MHz;Duty Cycle: 1:1

Medium parameters used:  $\sigma = 0$  mho/m,  $\epsilon_r = 1$ ;  $\rho = 1$  kg/m<sup>3</sup>

Phantom section: H Device Section

DASY4 Configuration:

- Probe: H3DV6 - SN6197; ; Calibrated: 2008-04-21

- Sensor-Surface: (Fix Surface)

- Electronics: DAE4 Sn724; Calibrated: 2008-02-28

- Phantom: HAC Test Arch with Coil; Type: SD HAC P01 BA; Serial: 1018

- Measurement SW: DASY4, V4.7 Build 71; Postprocessing SW: SEMCAD, V1.8 Build 184

### **Ch.0025, Ant. Intenna, Bat. Standard(RC3/SO55)/Hearing Aid Compatibility Test**

**(101x101x1):** Measurement grid: dx=5mm, dy=5mm

Maximum value of peak Total field = 0.127 A/m

Probe Modulation Factor = 1.01

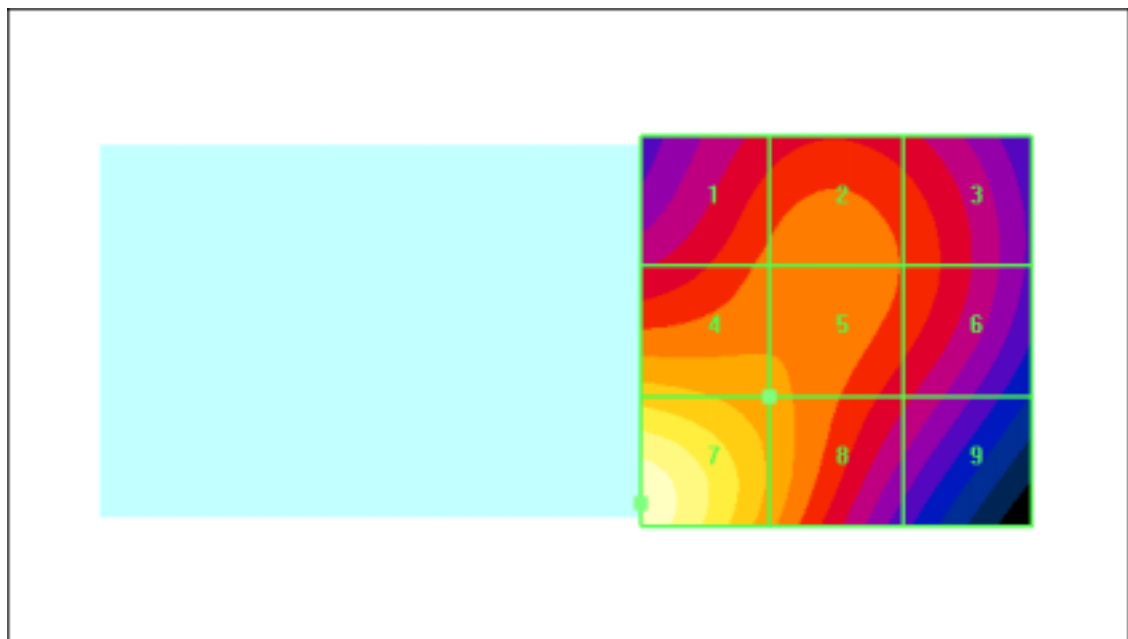
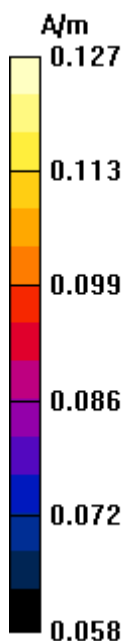
Device Reference Point: 0.000, 0.000, 353.7 mm

Reference Value = 0.111 A/m; Power Drift = 0.007 dB

**Hearing Aid Near-Field Category: M4 (AWF 0 dB)**

Peak H-field in A/m

Grid 1 <b>0.101 M4</b>	Grid 2 <b>0.103 M4</b>	Grid 3 <b>0.099 M4</b>
Grid 4 <b>0.112 M4</b>	Grid 5 <b>0.106 M4</b>	Grid 6 <b>0.099 M4</b>
Grid 7 <b>0.127 M4</b>	Grid 8 <b>0.108 M4</b>	Grid 9 <b>0.092 M4</b>



**DUT: SCH-U940; Serial: AF-102-A**

**Program Name: SCH-U940(PCS) H-Field, Slide Close, Date:2008/11/25**

**Procedure Name: Ch.0600, Ant. Intenna, Bat. Standard(RC3/SO55)**

Communication System: PCS; Frequency: 1880 MHz; Duty Cycle: 1:1

Medium parameters used:  $\sigma = 0$  mho/m,  $\epsilon_r = 1$ ;  $\rho = 1$  kg/m<sup>3</sup>

Phantom section: H Device Section

DASY4 Configuration:

- Probe: H3DV6 - SN6197; ; Calibrated: 2008-04-21

- Sensor-Surface: (Fix Surface)

- Electronics: DAE4 Sn724; Calibrated: 2008-02-28

- Phantom: HAC Test Arch with Coil; Type: SD HAC P01 BA; Serial: 1018

- Measurement SW: DASY4, V4.7 Build 71; Postprocessing SW: SEMCAD, V1.8 Build 184

**Ch.0600, Ant. Intenna, Bat. Standard(RC3/SO55)/Hearing Aid Compatibility Test**

**(101x101x1):** Measurement grid: dx=5mm, dy=5mm

Maximum value of peak Total field = 0.110 A/m

Probe Modulation Factor = 1.01

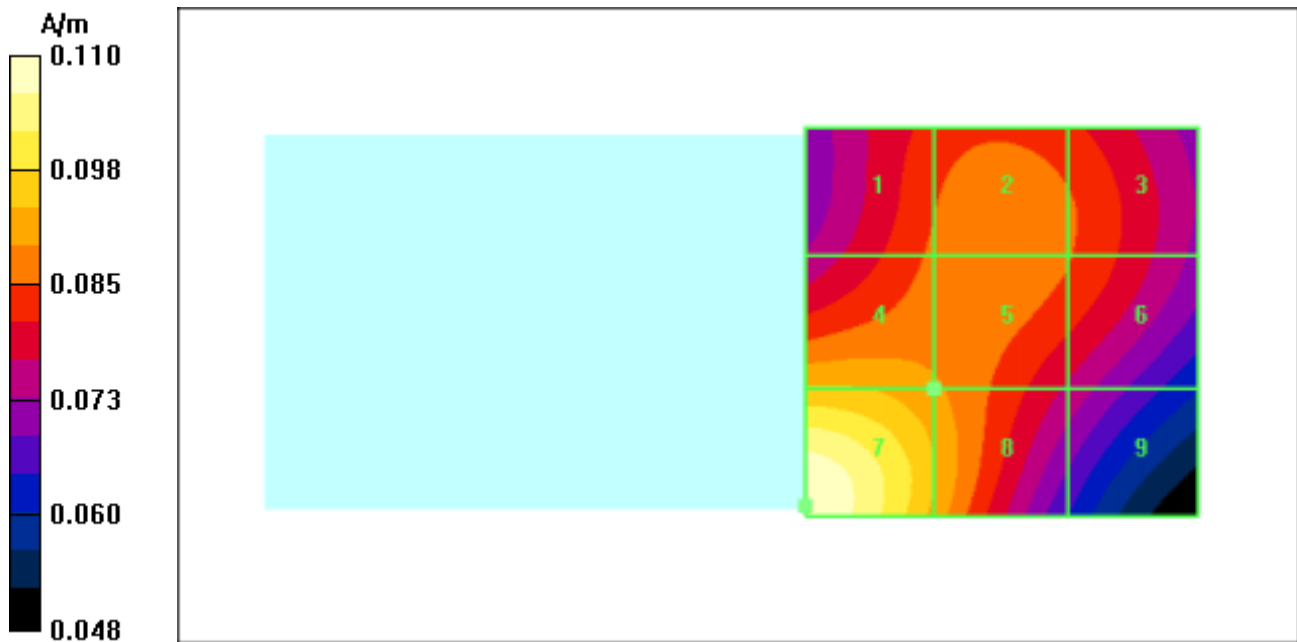
Device Reference Point: 0.000, 0.000, 353.7 mm

Reference Value = 0.093 A/m; Power Drift = -0.017 dB

**Hearing Aid Near-Field Category: M4 (AWF 0 dB)**

Peak H-field in A/m

Grid 1 <b>0.086 M4</b>	Grid 2 <b>0.089 M4</b>	Grid 3 <b>0.086 M4</b>
Grid 4 <b>0.094 M4</b>	Grid 5 <b>0.090 M4</b>	Grid 6 <b>0.086 M4</b>
Grid 7 <b>0.110 M4</b>	Grid 8 <b>0.094 M4</b>	Grid 9 <b>0.076 M4</b>



**DUT: SCH-U940; Serial: AF-102-A**

**Program Name: SCH-U940(PCS) H-Field, Slide Close, Date:2008/11/25**

**Procedure Name: Ch.1175, Ant. Intenna, Bat. Standard(RC3/SO55)**

Communication System: PCS; Frequency: 1908.75 MHz;Duty Cycle: 1:1

Medium parameters used:  $\sigma = 0$  mho/m,  $\epsilon_r = 1$ ;  $\rho = 1$  kg/m<sup>3</sup>

Phantom section: H Device Section

DASY4 Configuration:

- Probe: H3DV6 - SN6197; ; Calibrated: 2008-04-21

- Sensor-Surface: (Fix Surface)

- Electronics: DAE4 Sn724; Calibrated: 2008-02-28

- Phantom: HAC Test Arch with Coil; Type: SD HAC P01 BA; Serial: 1018

- Measurement SW: DASY4, V4.7 Build 71; Postprocessing SW: SEMCAD, V1.8 Build 184

### **Ch.1175, Ant. Intenna, Bat. Standard(RC3/SO55)/Hearing Aid Compatibility Test**

**(101x101x1):** Measurement grid: dx=5mm, dy=5mm

Maximum value of peak Total field = 0.118 A/m

Probe Modulation Factor = 1.01

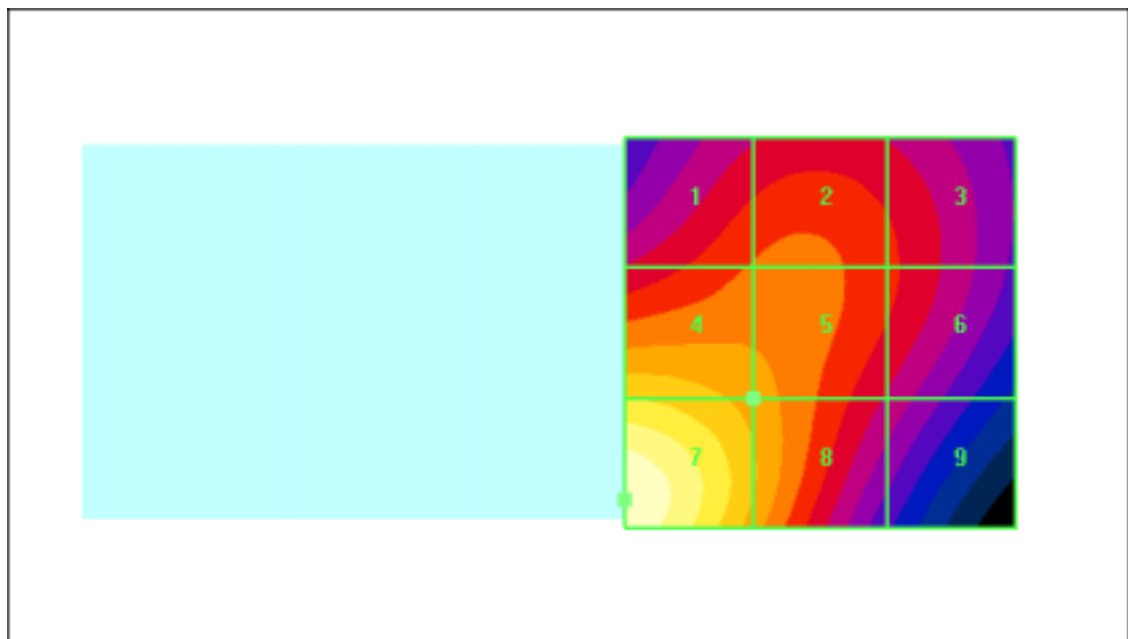
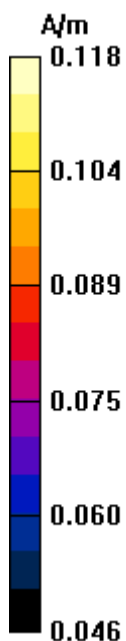
Device Reference Point: 0.000, 0.000, 353.7 mm

Reference Value = 0.099 A/m; Power Drift = -0.032 dB

**Hearing Aid Near-Field Category: M4 (AWF 0 dB)**

Peak H-field in A/m

Grid 1 <b>0.090 M4</b>	Grid 2 <b>0.091 M4</b>	Grid 3 <b>0.086 M4</b>
Grid 4 <b>0.104 M4</b>	Grid 5 <b>0.097 M4</b>	Grid 6 <b>0.086 M4</b>
Grid 7 <b>0.118 M4</b>	Grid 8 <b>0.099 M4</b>	Grid 9 <b>0.079 M4</b>



**DUT: SCH-U940; Serial: AF-102-A**

**Program Name: SCH-U940(CDMA) H-Field, Slide Open, Date: 2008/11/25**

**Procedure Name: Ch.1013, Ant, Intenna, Bat. Standard(RC3/SO55)**

Communication System: CDMA(HAC); Frequency: 824.7 MHz; Duty Cycle: 1:1

Medium parameters used:  $\sigma = 0$  mho/m,  $\epsilon_r = 1$ ;  $\rho = 1$  kg/m<sup>3</sup>

Phantom section: H Device Section

DASY4 Configuration:

- Probe: H3DV6 - SN6197; ; Calibrated: 2008-04-21

- Sensor-Surface: (Fix Surface)

- Electronics: DAE4 Sn724; Calibrated: 2008-02-28

- Phantom: HAC Test Arch with Coil; Type: SD HAC P01 BA; Serial: 1018

- Measurement SW: DASY4, V4.7 Build 71; Postprocessing SW: SEMCAD, V1.8 Build 184

### **Ch.1013, Ant, Intenna, Bat. Standard(RC3/SO55)/Hearing Aid Compatibility Test**

**(101x101x1):** Measurement grid: dx=5mm, dy=5mm

Maximum value of peak Total field = 0.101 A/m

Probe Modulation Factor = 1.02

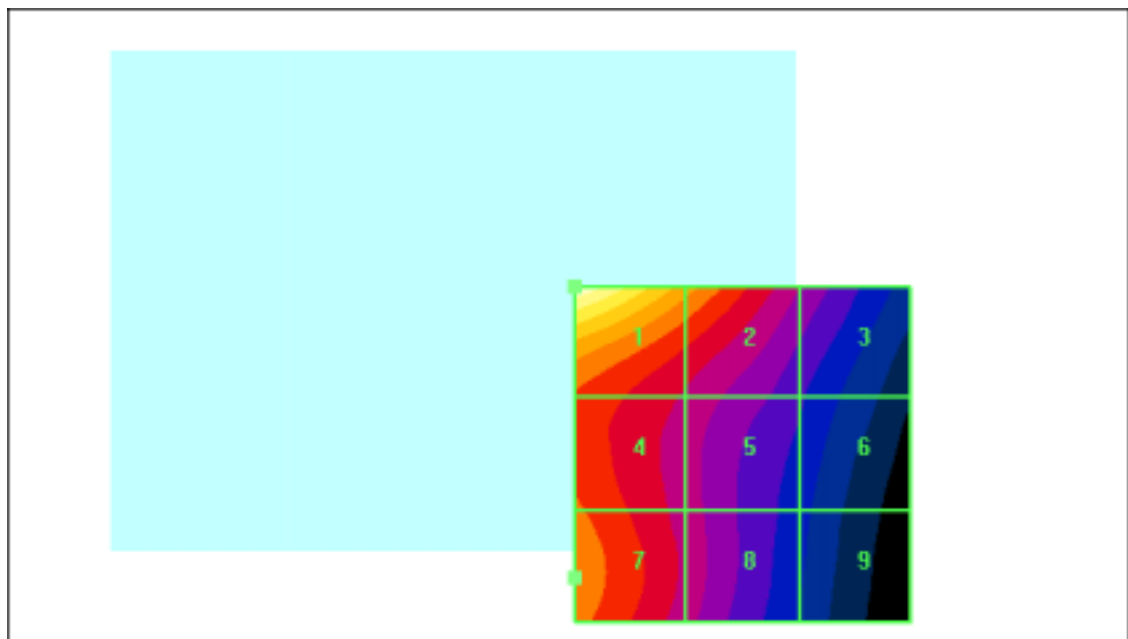
Device Reference Point: 0.000, 0.000, 353.7 mm

Reference Value = 0.050 A/m; Power Drift = 0.070 dB

**Hearing Aid Near-Field Category: M4 (AWF 0 dB)**

Peak H-field in A/m

Grid 1 <b>0.101 M4</b>	Grid 2 <b>0.078 M4</b>	Grid 3 <b>0.056 M4</b>
Grid 4 <b>0.072 M4</b>	Grid 5 <b>0.060 M4</b>	Grid 6 <b>0.046 M4</b>
Grid 7 <b>0.075 M4</b>	Grid 8 <b>0.059 M4</b>	Grid 9 <b>0.042 M4</b>



**DUT: SCH-U940; Serial: AF-102-A**

**Program Name: SCH-U940(CDMA) H-Field, Slide Open, Date: 2008/11/25**

**Procedure Name: Ch.0384, Ant, Intenna, Bat. Standard(RC3/SO55)**

Communication System: CDMA(HAC); Frequency: 836.52 MHz; Duty Cycle: 1:1

Medium parameters used:  $\sigma = 0$  mho/m,  $\epsilon_r = 1$ ;  $\rho = 1$  kg/m<sup>3</sup>

Phantom section: H Device Section

DASY4 Configuration:

- Probe: H3DV6 - SN6197; ; Calibrated: 2008-04-21

- Sensor-Surface: (Fix Surface)

- Electronics: DAE4 Sn724; Calibrated: 2008-02-28

- Phantom: HAC Test Arch with Coil; Type: SD HAC P01 BA; Serial: 1018

- Measurement SW: DASY4, V4.7 Build 71; Postprocessing SW: SEMCAD, V1.8 Build 184

### **Ch.0384, Ant, Intenna, Bat. Standard(RC3/SO55)/Hearing Aid Compatibility Test**

**(101x101x1):** Measurement grid: dx=5mm, dy=5mm

Maximum value of peak Total field = 0.131 A/m

Probe Modulation Factor = 1.02

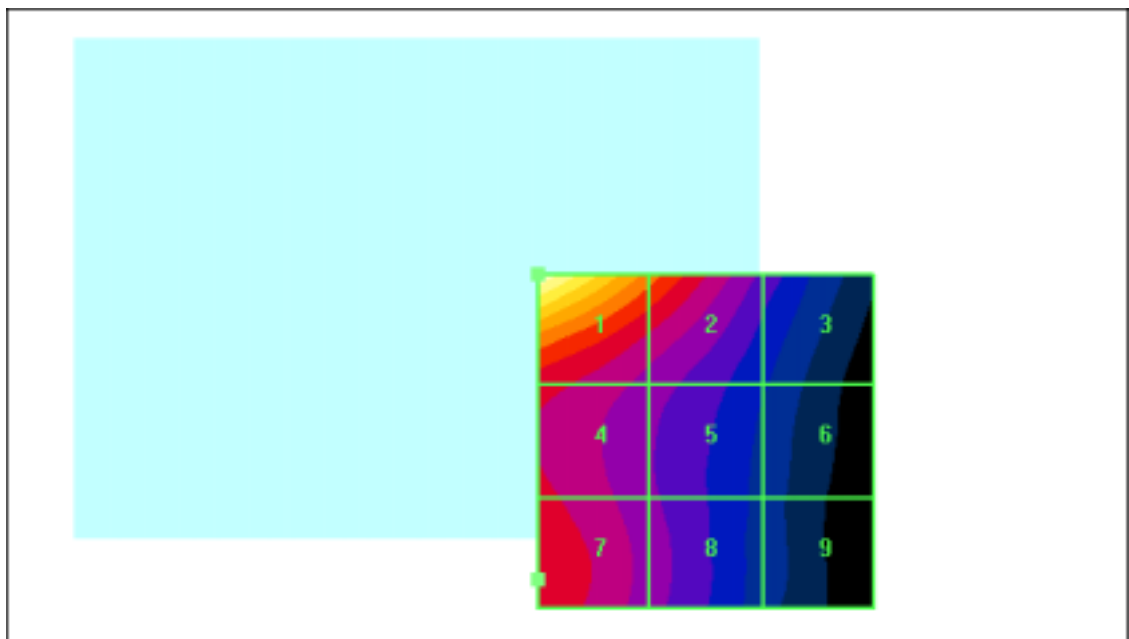
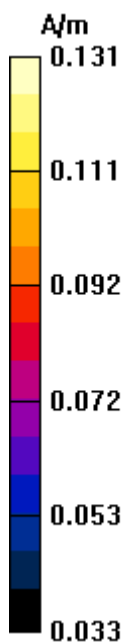
Device Reference Point: 0.000, 0.000, 353.7 mm

Reference Value = 0.058 A/m; Power Drift = 0.142 dB

**Hearing Aid Near-Field Category: M4 (AWF 0 dB)**

Peak H-field in A/m

Grid 1 <b>0.131 M4</b>	Grid 2 <b>0.096 M4</b>	Grid 3 <b>0.064 M4</b>
Grid 4 <b>0.082 M4</b>	Grid 5 <b>0.070 M4</b>	Grid 6 <b>0.054 M4</b>
Grid 7 <b>0.086 M4</b>	Grid 8 <b>0.070 M4</b>	Grid 9 <b>0.050 M4</b>



**DUT: SCH-U940; Serial: AF-102-A**

**Program Name: SCH-U940(CDMA) H-Field, Slide Open, Date: 2008/11/25**

**Procedure Name: Ch.0777, Ant, Intenna, Bat. Standard(RC3/SO55)**

Communication System: CDMA(HAC); Frequency: 848.31 MHz; Duty Cycle: 1:1

Medium parameters used:  $\sigma = 0$  mho/m,  $\epsilon_r = 1$ ;  $\rho = 1$  kg/m<sup>3</sup>

Phantom section: H Device Section

DASY4 Configuration:

- Probe: H3DV6 - SN6197; ; Calibrated: 2008-04-21

- Sensor-Surface: (Fix Surface)

- Electronics: DAE4 Sn724; Calibrated: 2008-02-28

- Phantom: HAC Test Arch with Coil; Type: SD HAC P01 BA; Serial: 1018

- Measurement SW: DASY4, V4.7 Build 71; Postprocessing SW: SEMCAD, V1.8 Build 184

### **Ch.0777, Ant, Intenna, Bat. Standard(RC3/SO55)/Hearing Aid Compatibility Test**

**(101x101x1):** Measurement grid: dx=5mm, dy=5mm

Maximum value of peak Total field = 0.144 A/m

Probe Modulation Factor = 1.02

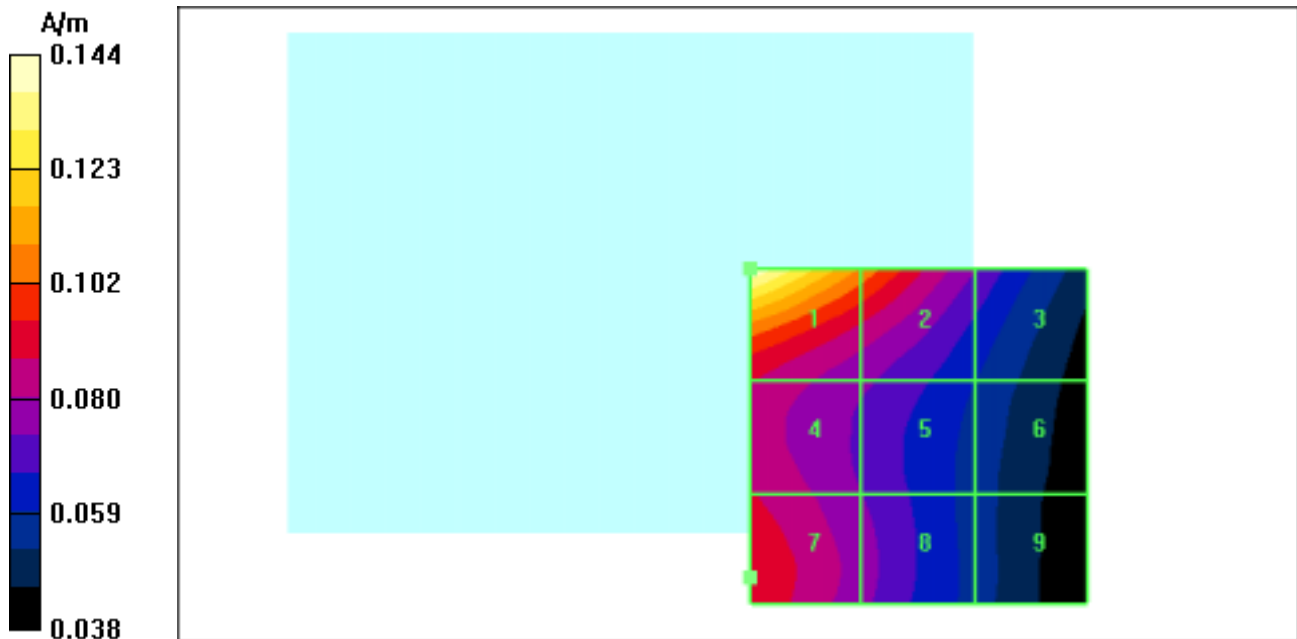
Device Reference Point: 0.000, 0.000, 353.7 mm

Reference Value = 0.063 A/m; Power Drift = 0.165 dB

**Hearing Aid Near-Field Category: M4 (AWF 0 dB)**

Peak H-field in A/m

Grid 1 <b>0.144 M4</b>	Grid 2 <b>0.107 M4</b>	Grid 3 <b>0.074 M4</b>
Grid 4 <b>0.088 M4</b>	Grid 5 <b>0.076 M4</b>	Grid 6 <b>0.060 M4</b>
Grid 7 <b>0.094 M4</b>	Grid 8 <b>0.077 M4</b>	Grid 9 <b>0.057 M4</b>



**DUT: SCH-U940; Serial: AF-102-A**

**Program Name: SCH-U940(PCS) H-Field, Slide Open, Date:2008/11/25**

**Procedure Name: Ch.0025, Ant. Intenna, Bat. Standard(RC3/SO55)**

Communication System: PCS; Frequency: 1851.25 MHz;Duty Cycle: 1:1

Medium parameters used:  $\sigma = 0$  mho/m,  $\epsilon_r = 1$ ;  $\rho = 1$  kg/m<sup>3</sup>

Phantom section: H Device Section

DASY4 Configuration:

- Probe: H3DV6 - SN6197; ; Calibrated: 2008-04-21

- Sensor-Surface: (Fix Surface)

- Electronics: DAE4 Sn724; Calibrated: 2008-02-28

- Phantom: HAC Test Arch with Coil; Type: SD HAC P01 BA; Serial: 1018

- Measurement SW: DASY4, V4.7 Build 71; Postprocessing SW: SEMCAD, V1.8 Build 184

**Ch.0025, Ant. Intenna, Bat. Standard(RC3/SO55)/Hearing Aid Compatibility Test**

**(101x101x1):** Measurement grid: dx=5mm, dy=5mm

Maximum value of peak Total field = 0.114 A/m

Probe Modulation Factor = 1.01

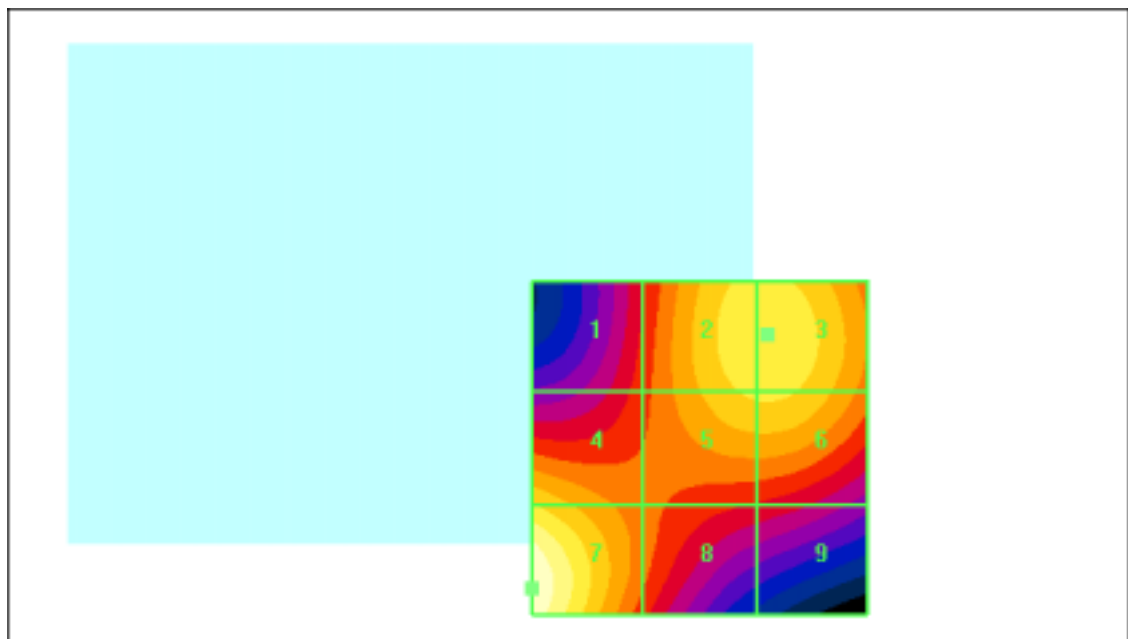
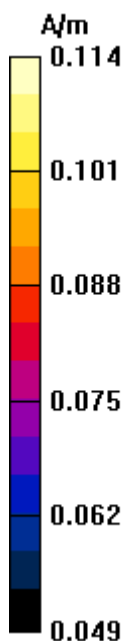
Device Reference Point: 0.000, 0.000, 353.7 mm

Reference Value = 0.099 A/m; Power Drift = -0.043 dB

**Hearing Aid Near-Field Category: M4 (AWF 0 dB)**

Peak H-field in A/m

Grid 1 <b>0.086 M4</b>	Grid 2 <b>0.105 M4</b>	Grid 3 <b>0.105 M4</b>
Grid 4 <b>0.101 M4</b>	Grid 5 <b>0.102 M4</b>	Grid 6 <b>0.102 M4</b>
Grid 7 <b>0.114 M4</b>	Grid 8 <b>0.090 M4</b>	Grid 9 <b>0.083 M4</b>



**DUT: SCH-U940; Serial: AF-102-A**

**Program Name: SCH-U940(PCS) H-Field, Slide Open, Date:2008/11/25**

**Procedure Name: Ch.0600, Ant. Intenna, Bat. Standard(RC3/SO55)**

Communication System: PCS; Frequency: 1880 MHz;Duty Cycle: 1:1

Medium parameters used:  $\sigma = 0$  mho/m,  $\epsilon_r = 1$ ;  $\rho = 1$  kg/m<sup>3</sup>

Phantom section: H Device Section

DASY4 Configuration:

- Probe: H3DV6 - SN6197; ; Calibrated: 2008-04-21

- Sensor-Surface: (Fix Surface)

- Electronics: DAE4 Sn724; Calibrated: 2008-02-28

- Phantom: HAC Test Arch with Coil; Type: SD HAC P01 BA; Serial: 1018

- Measurement SW: DASY4, V4.7 Build 71; Postprocessing SW: SEMCAD, V1.8 Build 184

### **Ch.0600, Ant. Intenna, Bat. Standard(RC3/SO55)/Hearing Aid Compatibility Test**

**(101x101x1):** Measurement grid: dx=5mm, dy=5mm

Maximum value of peak Total field = 0.103 A/m

Probe Modulation Factor = 1.01

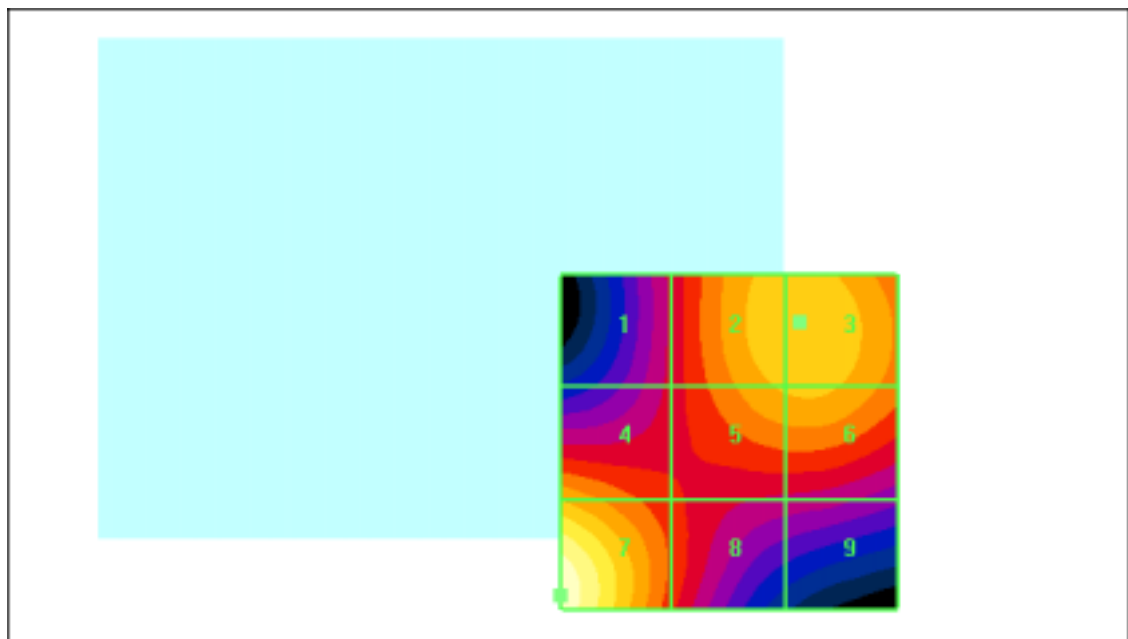
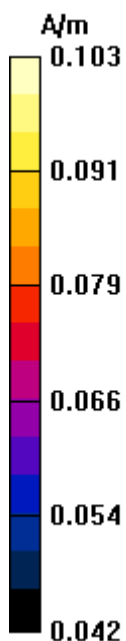
Device Reference Point: 0.000, 0.000, 353.7 mm

Reference Value = 0.083 A/m; Power Drift = -0.044 dB

**Hearing Aid Near-Field Category: M4 (AWF 0 dB)**

Peak H-field in A/m

Grid 1 <b>0.072 M4</b>	Grid 2 <b>0.090 M4</b>	Grid 3 <b>0.091 M4</b>
Grid 4 <b>0.086 M4</b>	Grid 5 <b>0.088 M4</b>	Grid 6 <b>0.088 M4</b>
Grid 7 <b>0.103 M4</b>	Grid 8 <b>0.078 M4</b>	Grid 9 <b>0.070 M4</b>



**DUT: SCH-U940; Serial: AF-102-A**

**Program Name: SCH-U940(PCS) H-Field, Slide Open, Date:2008/11/25**

**Procedure Name: Ch.1175, Ant. Intenna, Bat. Standard(RC3/SO55)**

Communication System: PCS; Frequency: 1908.75 MHz;Duty Cycle: 1:1

Medium parameters used:  $\sigma = 0$  mho/m,  $\epsilon_r = 1$ ;  $\rho = 1$  kg/m<sup>3</sup>

Phantom section: H Device Section

DASY4 Configuration:

- Probe: H3DV6 - SN6197; ; Calibrated: 2008-04-21

- Sensor-Surface: (Fix Surface)

- Electronics: DAE4 Sn724; Calibrated: 2008-02-28

- Phantom: HAC Test Arch with Coil; Type: SD HAC P01 BA; Serial: 1018

- Measurement SW: DASY4, V4.7 Build 71; Postprocessing SW: SEMCAD, V1.8 Build 184

### **Ch.1175, Ant. Intenna, Bat. Standard(RC3/SO55)/Hearing Aid Compatibility Test**

**(101x101x1):** Measurement grid: dx=5mm, dy=5mm

Maximum value of peak Total field = 0.100 A/m

Probe Modulation Factor = 1.01

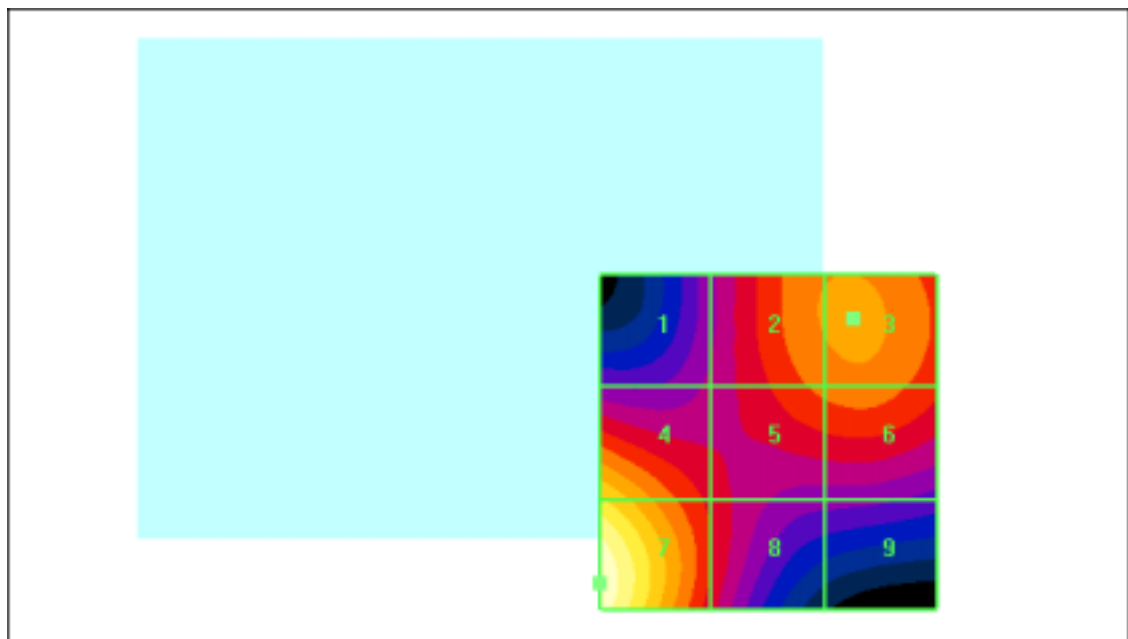
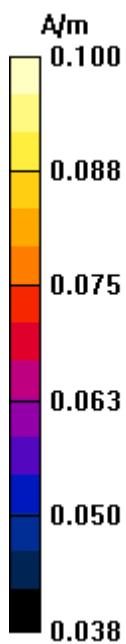
Device Reference Point: 0.000, 0.000, 353.7 mm

Reference Value = 0.073 A/m; Power Drift = -0.031 dB

**Hearing Aid Near-Field Category: M4 (AWF 0 dB)**

Peak H-field in A/m

Grid 1 <b>0.064 M4</b>	Grid 2 <b>0.080 M4</b>	Grid 3 <b>0.081 M4</b>
Grid 4 <b>0.088 M4</b>	Grid 5 <b>0.077 M4</b>	Grid 6 <b>0.078 M4</b>
Grid 7 <b>0.100 M4</b>	Grid 8 <b>0.071 M4</b>	Grid 9 <b>0.061 M4</b>





## **APPENDIX E**

### **Probe Calibration(E-field)**



Accredited by the Swiss Accreditation Service (SAS)

Accreditation No.: **SCS 108**

The Swiss Accreditation Service is one of the signatories to the EA Multilateral Agreement for the recognition of calibration certificates

Client **Samsung (Dymstec)**

Certificate No: **ER3-2370\_Apr08**

## CALIBRATION CERTIFICATE

Object **ER3DV6 - SN:2370**

Calibration procedure(s) **QA CAL-02.v5  
Calibration procedure for E-field probes optimized for close near field evaluations in air**

Calibration date: **April 21, 2008**

Condition of the calibrated item **In Tolerance**

This calibration certificate documents the traceability to national standards, which realize the physical units of measurements (SI). The measurements and the uncertainties with confidence probability are given on the following pages and are part of the certificate.

All calibrations have been conducted in the closed laboratory facility: environment temperature (22 ± 3)°C and humidity < 70%.

Calibration Equipment used (M&TE critical for calibration)

Primary Standards	ID #	Cal Date (Certificate No.)	Scheduled Calibration
Power meter E4419B	GB41293874	1-Apr-08 (No. 217-00788)	Apr-09
Power sensor E4412A	MY41495277	1-Apr-08 (No. 217-00788)	Apr-09
Power sensor E4412A	MY41498087	1-Apr-08 (No. 217-00788)	Apr-09
Reference 3 dB Attenuator	SN: S5054 (3c)	8-Aug-07 (No. 217-00719)	Aug-08
Reference 20 dB Attenuator	SN: S5086 (20b)	31-Mar-08 (No. 217-00787)	Apr-09
Reference 30 dB Attenuator	SN: S5129 (30b)	8-Aug-07 (No. 217-00720)	Aug-08
Reference Probe ER3DV6	SN: 2328	2-Oct-07 (No. ER3-2328_Oct07)	Oct-08
DAE4	SN: 660	3-Sep-07 (No. DAE4-660_Sep07)	Sep-08
Secondary Standards	ID #	Check Date (in house)	Scheduled Check
RF generator HP 8648C	US3642U01700	4-Aug-99 (in house check Oct-07)	In house check: Oct-09
Network Analyzer HP 8753E	US37390585	18-Oct-01 (in house check Oct-07)	In house check: Oct-08

	Name	Function	Signature
Calibrated by:	Katja Pokovic	Technical Manager	
Approved by:	Niels Kuster	Quality Manager	

Issued: April 21, 2008

This calibration certificate shall not be reproduced except in full without written approval of the laboratory.

*OK to use*  
*2008. 5. 13.*

**Calibration Laboratory of  
Schmid & Partner  
Engineering AG**  
Zeughausstrasse 43, 8004 Zurich, Switzerland



**S** Schweizerischer Kalibrierdienst  
**S** Service suisse d'étalonnage  
**C** Servizio svizzero di taratura  
**S** Swiss Calibration Service

Accredited by the Swiss Accreditation Service (SAS)  
The Swiss Accreditation Service is one of the signatories to the EA  
Multilateral Agreement for the recognition of calibration certificates

Accreditation No.: **SCS 108**

### Glossary:

NORM <sub>x,y,z</sub>	sensitivity in free space
DCP	diode compression point
Polarization $\varphi$	$\varphi$ rotation around probe axis
Polarization $\vartheta$	$\vartheta$ rotation around an axis that is in the plane normal to probe axis (at measurement center), i.e., $\vartheta = 0$ is normal to probe axis
Connector Angle	information used in DASY system to align probe sensor X to the robot coordinate system

### Calibration is Performed According to the Following Standards:

- IEEE Std 1309-2005, "IEEE Standard for calibration of electromagnetic field sensors and probes, excluding antennas, from 9 kHz to 40 GHz", December 2005.

### Methods Applied and Interpretation of Parameters:

- NORM<sub>x,y,z</sub>**: Assessed for E-field polarization  $\vartheta = 0$  for XY sensors and  $\vartheta = 90$  for Z sensor ( $f \leq 900$  MHz in TEM-cell;  $f > 1800$  MHz: R22 waveguide).
- NORM(f)<sub>x,y,z</sub>** = NORM<sub>x,y,z</sub> \* frequency\_response (see Frequency Response Chart).
- DCP<sub>x,y,z</sub>**: DCP are numerical linearization parameters assessed based on the data of power sweep (no uncertainty required). DCP does not depend on frequency.
- Spherical isotropy (3D deviation from isotropy)**: in a locally homogeneous field realized using an open waveguide setup.
- Sensor Offset**: The sensor offset corresponds to the offset of virtual measurement center from the probe tip (on probe axis). No tolerance required.
- Connector Angle**: The angle is assessed using the information gained by determining the NORM<sub>x</sub> (no uncertainty required).

# Probe ER3DV6

## SN:2370

Manufactured:	October 12, 2005
Last calibrated:	April 20, 2007
Recalibrated:	April 21, 2008

Calibrated for DASY Systems

(Note: non-compatible with DASY2 system!)

**DASY - Parameters of Probe: ER3DV6 SN:2370****Sensitivity in Free Space [ $\mu\text{V}/(\text{V}/\text{m})^2$ ]**

NormX	<b>1.73</b> $\pm$ 10.1 % (k=2)
NormY	<b>1.61</b> $\pm$ 10.1 % (k=2)
NormZ	<b>1.96</b> $\pm$ 10.1 % (k=2)

**Diode Compression<sup>A</sup>**

DCP X	<b>95</b> mV
DCP Y	<b>95</b> mV
DCP Z	<b>98</b> mV

**Frequency Correction**

X	<b>0.0</b>
Y	<b>0.0</b>
Z	<b>0.0</b>

**Sensor Offset**

(Probe Tip to Sensor Center)

X	<b>2.5</b> mm
Y	<b>2.5</b> mm
Z	<b>2.5</b> mm

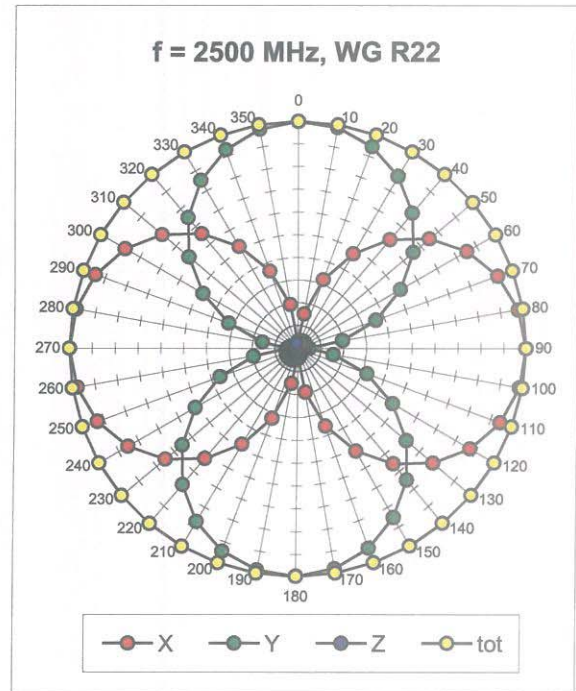
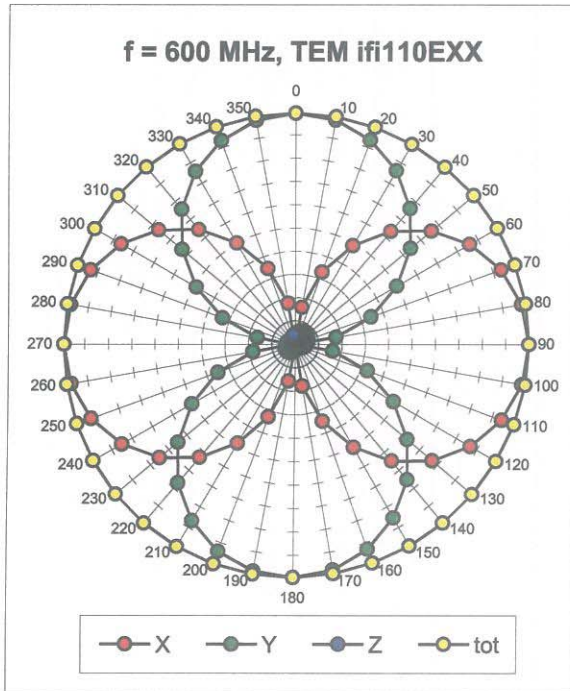
**Connector Angle****-227** °

**The reported uncertainty of measurement is stated as the standard uncertainty of measurement multiplied by the coverage factor k=2, which for a normal distribution corresponds to a coverage probability of approximately 95%.**

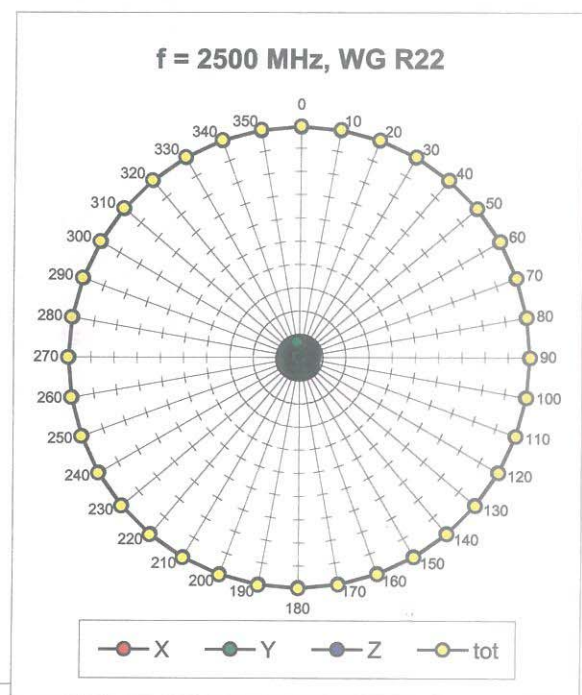
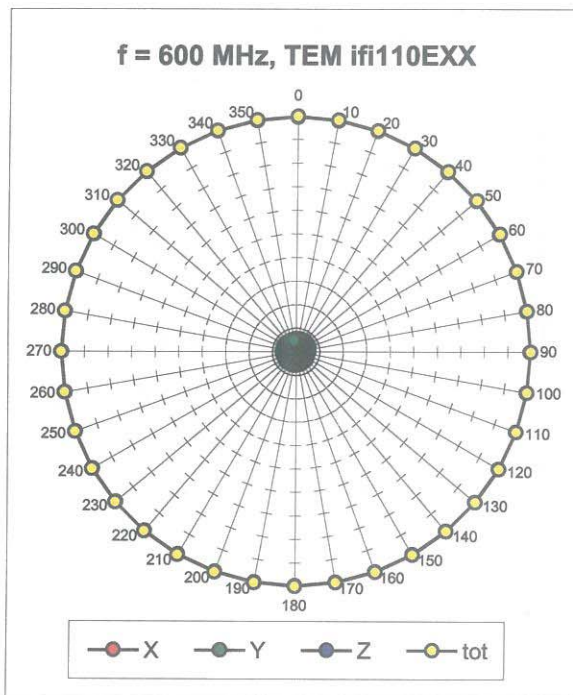
<sup>A</sup> numerical linearization parameter: uncertainty not required



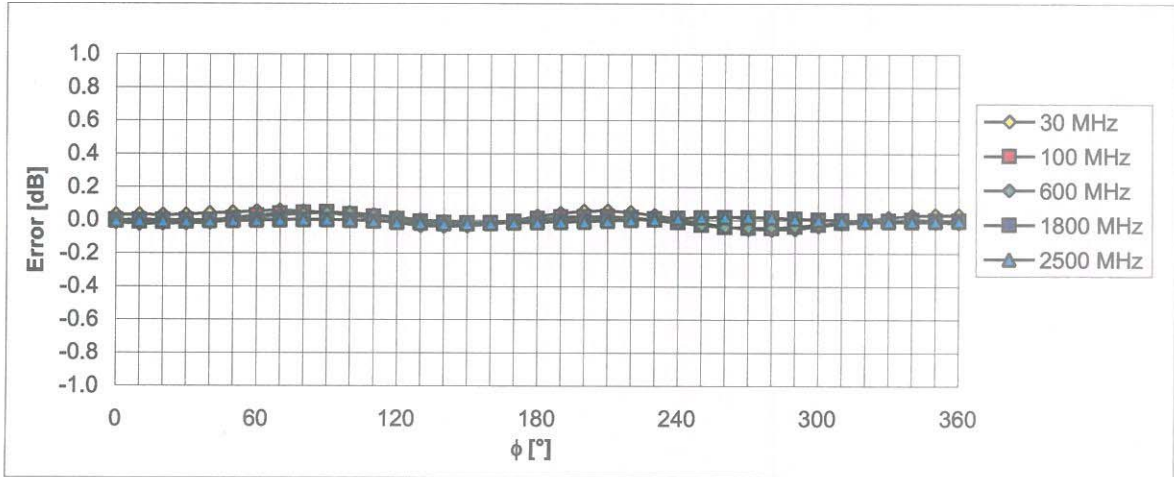
### Receiving Pattern ( $\phi$ ), $\vartheta = 0^\circ$



### Receiving Pattern ( $\phi$ ), $\vartheta = 90^\circ$

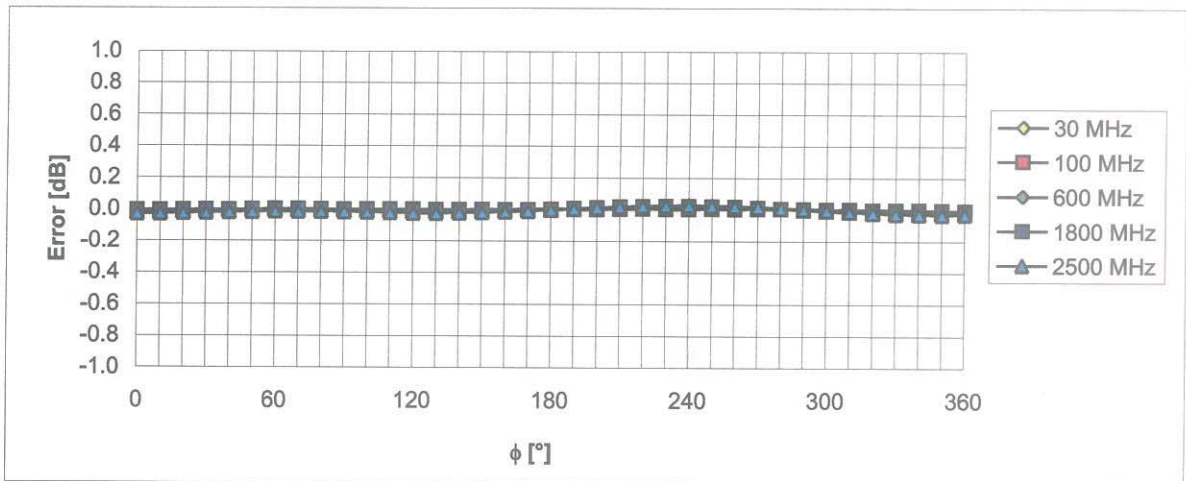


### Receiving Pattern ( $\phi$ ), $\vartheta = 0^\circ$



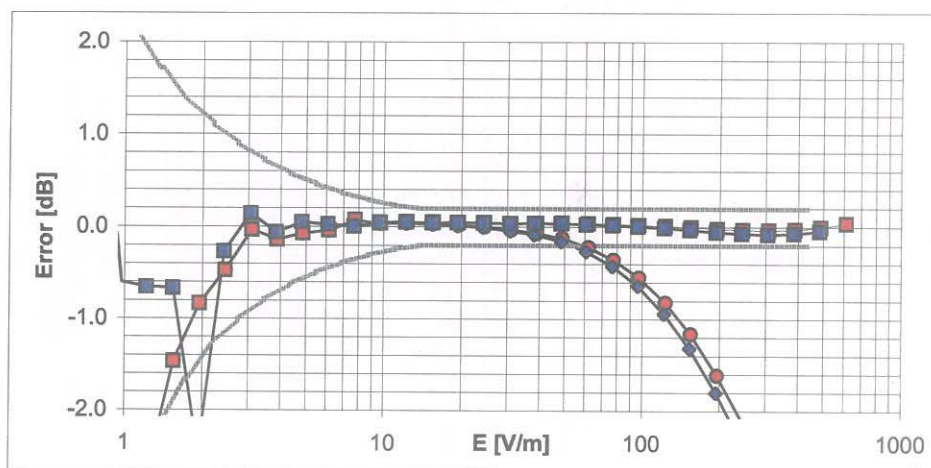
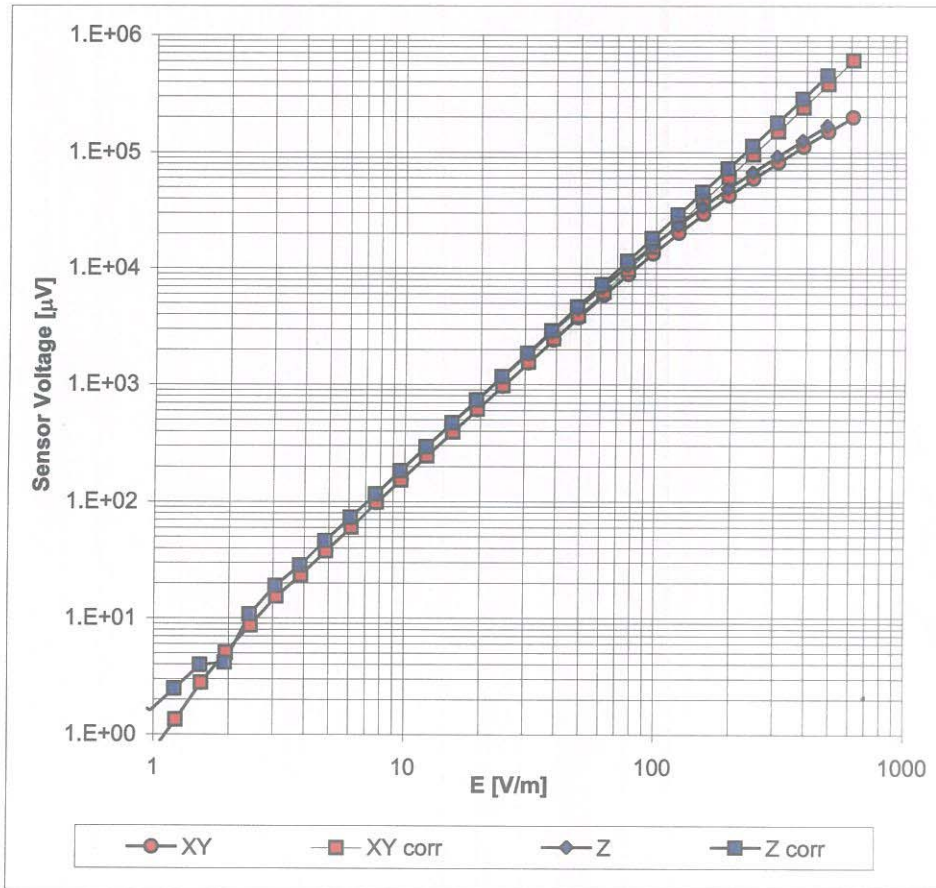
Uncertainty of Axial Isotropy Assessment:  $\pm 0.5\%$  (k=2)

### Receiving Pattern ( $\phi$ ), $\vartheta = 90^\circ$



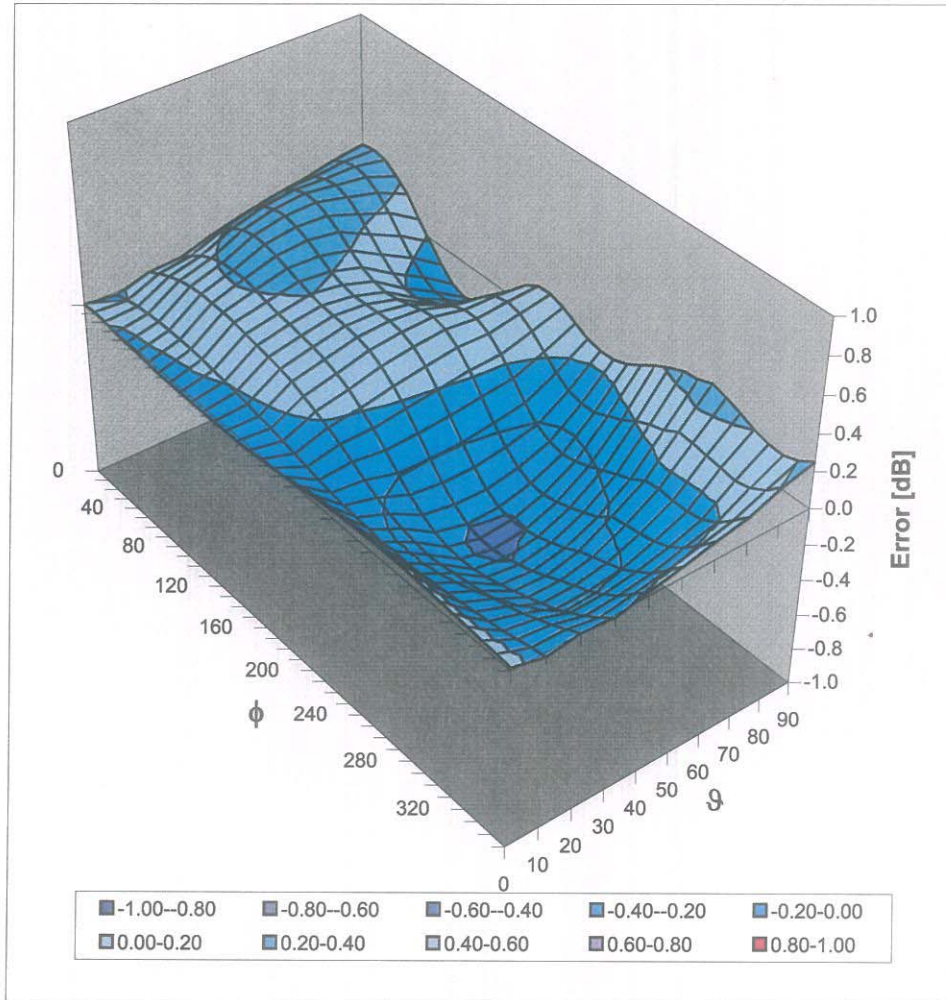
Uncertainty of Axial Isotropy Assessment:  $\pm 0.5\%$  (k=2)

### Dynamic Range f(E-field) (Waveguide R22, f = 1800 MHz)



Uncertainty of Linearity Assessment:  $\pm 0.6\%$  (k=2)

### Deviation from Isotropy in Air Error ( $\phi, \vartheta$ ), $f = 900$ MHz



Uncertainty of Spherical Isotropy Assessment:  $\pm 2.6\%$  ( $k=2$ )



## Probe Calibration(H-field)



Accredited by the Swiss Accreditation Service (SAS)  
The Swiss Accreditation Service is one of the signatories to the EA  
Multilateral Agreement for the recognition of calibration certificates

Accreditation No.: **SCS 108**

Client **Samsung (Dymstec)**

Certificate No: **H3-6197\_Apr08**

**CALIBRATION CERTIFICATE**

Object **H3DV6 - SN:6197**

Calibration procedure(s) **QA CAL-03.v5  
Calibration procedure for H-field probes optimized for close near field  
evaluations in air**

Calibration date: **April 21, 2008**


Condition of the calibrated item **In Tolerance**

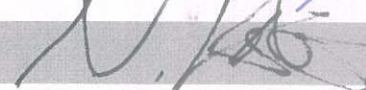
This calibration certificate documents the traceability to national standards, which realize the physical units of measurements (SI).  
The measurements and the uncertainties with confidence probability are given on the following pages and are part of the certificate.

All calibrations have been conducted in the closed laboratory facility: environment temperature (22 ± 3)°C and humidity < 70%.

Calibration Equipment used (M&TE critical for calibration)

Primary Standards	ID #	Cal Date (Certificate No.)	Scheduled Calibration
Power meter E4419B	GB41293874	1-Apr-08 (No. 217-00788)	Apr-09
Power sensor E4412A	MY41495277	1-Apr-08 (No. 217-00788)	Apr-09
Power sensor E4412A	MY41498087	1-Apr-08 (No. 217-00788)	Apr-09
Reference 3 dB Attenuator	SN: S5054 (3c)	8-Aug-07 (No. 217-00719)	Aug-08
Reference 20 dB Attenuator	SN: S5086 (20b)	31-Mar-08 (No. 217-00787)	Apr-09
Reference 30 dB Attenuator	SN: S5129 (30b)	8-Aug-07 (No. 217-00720)	Aug-08
Reference Probe H3DV6	SN: 6182	2-Oct-07 (No. H3-6182_Oct07)	Oct-08
DAE4	SN: 660	3-Sep-07 (No. DAE4-660_Sep07)	Sep-08
Secondary Standards	ID #	Check Date (in house)	Scheduled Check
RF generator HP 8648C	US3642U01700	4-Aug-99 (in house check Oct-07)	In house check: Oct-09
Network Analyzer HP 8753E	US37390585	18-Oct-01 (in house check Oct-07)	In house check: Oct-08

Calibrated by: **Katja Pokovic** (Name) **Technical Manager** (Function)  (Signature)

Approved by: **Niels Kuster** (Name) **Quality Manager** (Function)  (Signature)

Issued: April 21, 2008

This calibration certificate shall not be reproduced except in full without written approval of the laboratory.

*OK to use*  
*2008.5.13*

C10-11-108

**Calibration Laboratory of  
Schmid & Partner  
Engineering AG**  
Zeughausstrasse 43, 8004 Zurich, Switzerland



**S** Schweizerischer Kalibrierdienst  
**C** Service suisse d'étalonnage  
**S** Servizio svizzero di taratura  
**S** Swiss Calibration Service

Accredited by the Swiss Accreditation Service (SAS)  
The Swiss Accreditation Service is one of the signatories to the EA  
Multilateral Agreement for the recognition of calibration certificates

Accreditation No.: **SCS 108**

**Glossary:**

NORM<sub>x,y,z</sub> sensitivity in free space  
DCP diode compression point  
Polarization  $\varphi$   $\varphi$  rotation around probe axis  
Polarization  $\vartheta$   $\vartheta$  rotation around an axis that is in the plane normal to probe axis (at measurement center), i.e.,  $\vartheta = 0$  is normal to probe axis  
Connector Angle information used in DASY system to align probe sensor X to the robot coordinate system

**Calibration is Performed According to the Following Standards:**

- a) IEEE Std 1309-2005, " IEEE Standard for calibration of electromagnetic field sensors and probes, excluding antennas, from 9 kHz to 40 GHz", December 2005.

**Methods Applied and Interpretation of Parameters:**

- $X, Y, Z_{a0a1a2}$ : Assessed for E-field polarization  $\vartheta = 90$  for XY sensors and  $\vartheta = 0$  for Z sensor ( $f \leq 900$  MHz in TEM-cell;  $f > 1800$  MHz: R22 waveguide).
- $X, Y, Z(f)_{a0a1a2} = X, Y, Z_{a0a1a2} * \text{frequency\_response}$  (see Frequency Response Chart).
- $DCP_{x,y,z}$ : DCP are numerical linearization parameters assessed based on the data of power sweep (no uncertainty required). DCP does not depend on frequency.
- *Spherical isotropy (3D deviation from isotropy)*: in a locally homogeneous field realized using an open waveguide setup.
- *Sensor Offset*: The sensor offset corresponds to the offset of virtual measurement center from the probe tip (on probe axis). No tolerance required.
- *Connector Angle*: The angle is assessed using the information gained by determining the  $X_{a0a1a2}$  (no uncertainty required).

# Probe H3DV6

## SN:6197

Manufactured:	April 18, 2006
Last calibrated:	April 20, 2007
Recalibrated:	April 21, 2008

Calibrated for DASY Systems

(Note: non-compatible with DASY2 system!)

## DASY - Parameters of Probe: H3DV6 SN:6197

### Sensitivity in Free Space [A/m / $\sqrt{(\mu V)}$ ]

	a0	a1	a2
X	2.390E-03	1.510E-4	1.095E-4 ± 5.1 % (k=2)
Y	2.341E-03	2.382E-4	1.163E-4 ± 5.1 % (k=2)
Z	2.799E-03	4.460E-5	9.922E-5 ± 5.1 % (k=2)

### Diode Compression<sup>1</sup>

DCP X	85 mV
DCP Y	85 mV
DCP Z	85 mV

### Sensor Offset (Probe Tip to Sensor Center)

X	3.0 mm
Y	3.0 mm
Z	3.0 mm

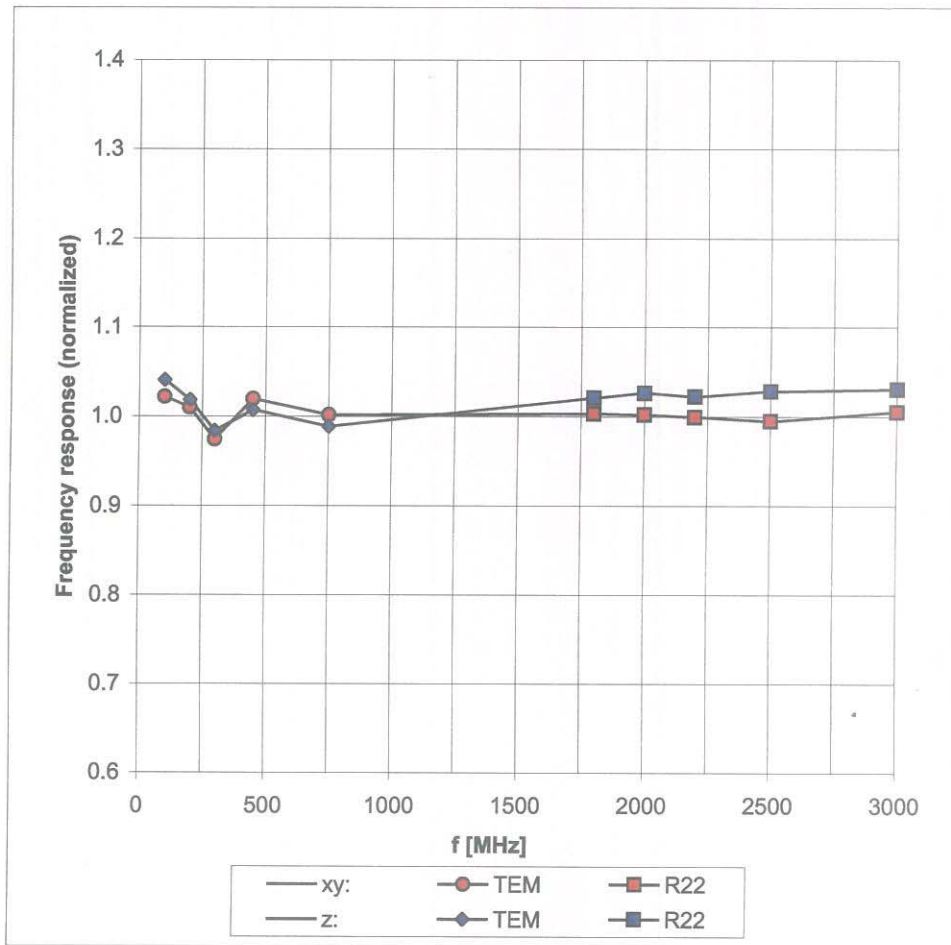
Connector Angle -201 °

The reported uncertainty of measurement is stated as the standard uncertainty of measurement multiplied by the coverage factor k=2, which for a normal distribution corresponds to a coverage probability of approximately 95%.

<sup>1</sup> numerical linearization parameter: uncertainty not required

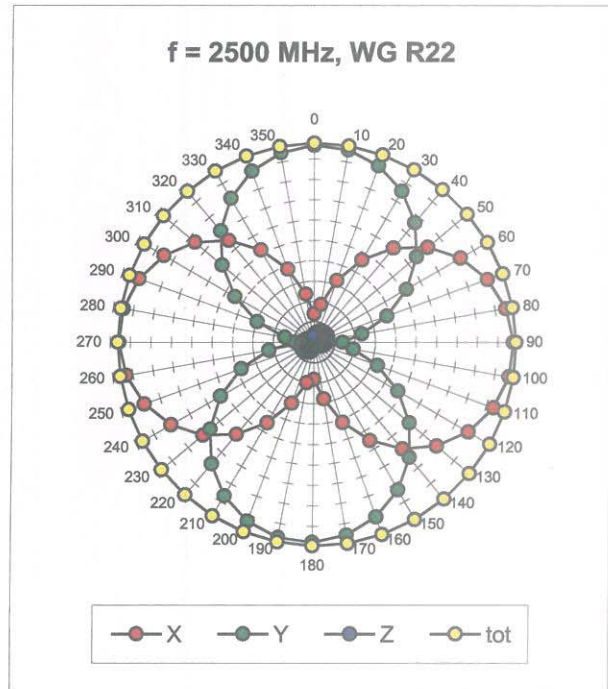
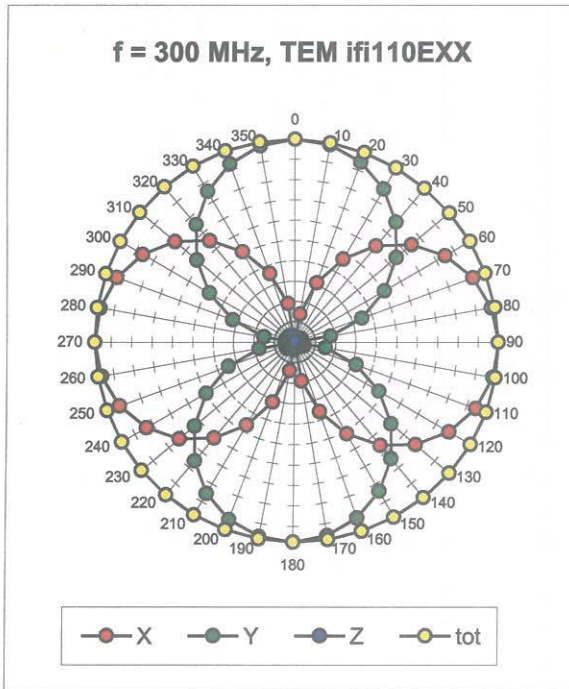
## Frequency Response of H-Field

(TEM-Cell:ifi110, Waveguide R22)

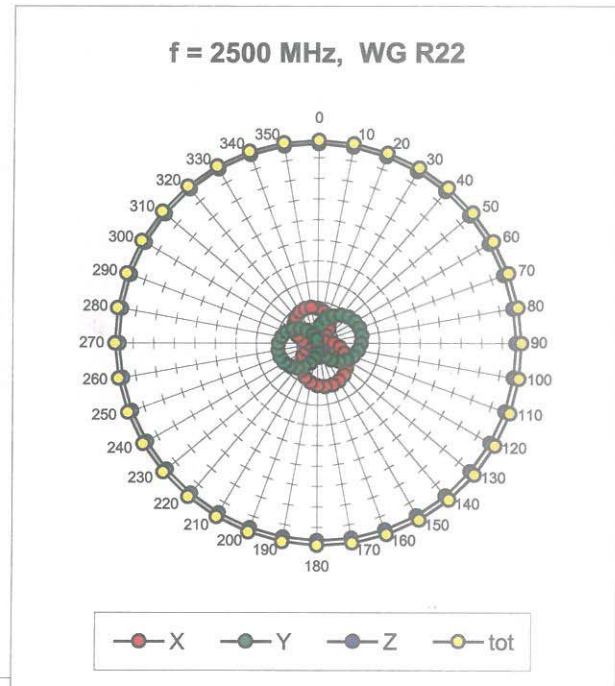
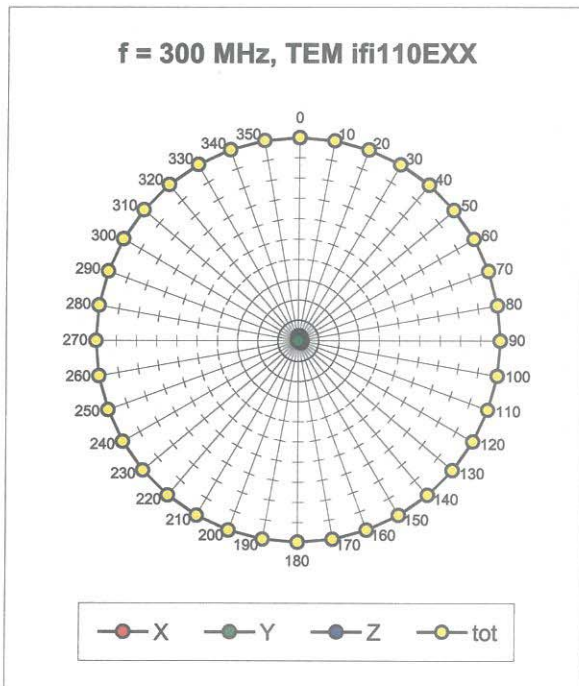


Uncertainty of Frequency Response of E-field:  $\pm 6.3\%$  (k=2)

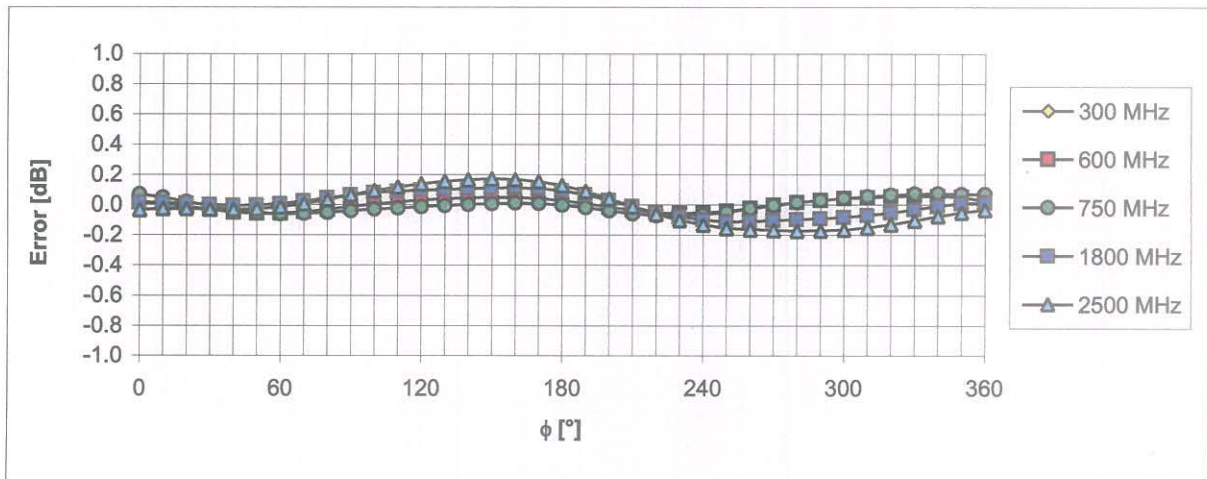
### Receiving Pattern ( $\phi$ ), $\vartheta = 90^\circ$



### Receiving Pattern ( $\phi$ ), $\vartheta = 0^\circ$

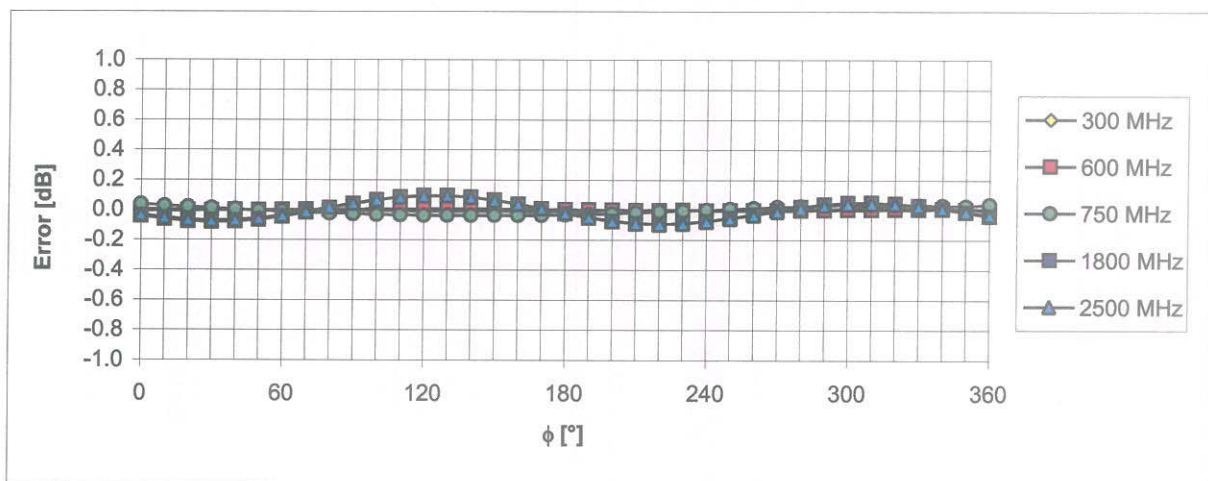


### Receiving Pattern ( $\phi$ ), $\vartheta = 90^\circ$



Uncertainty of Axial Isotropy Assessment:  $\pm 0.5\%$  (k=2)

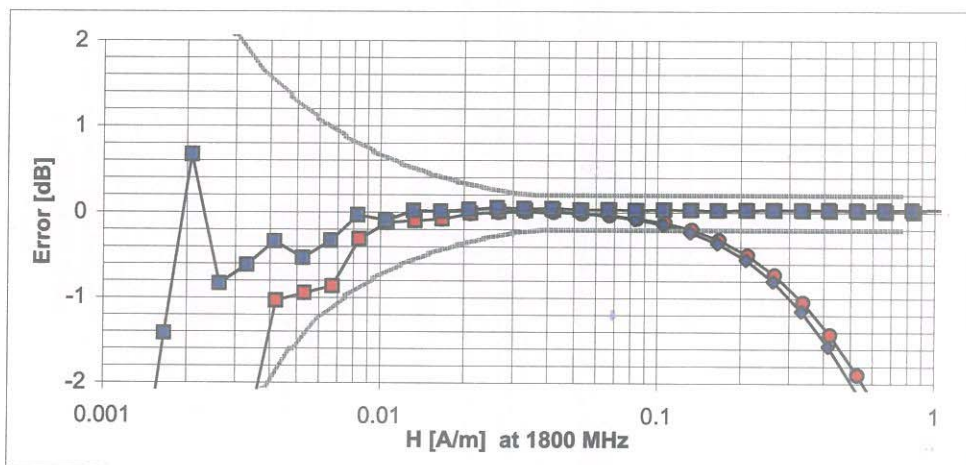
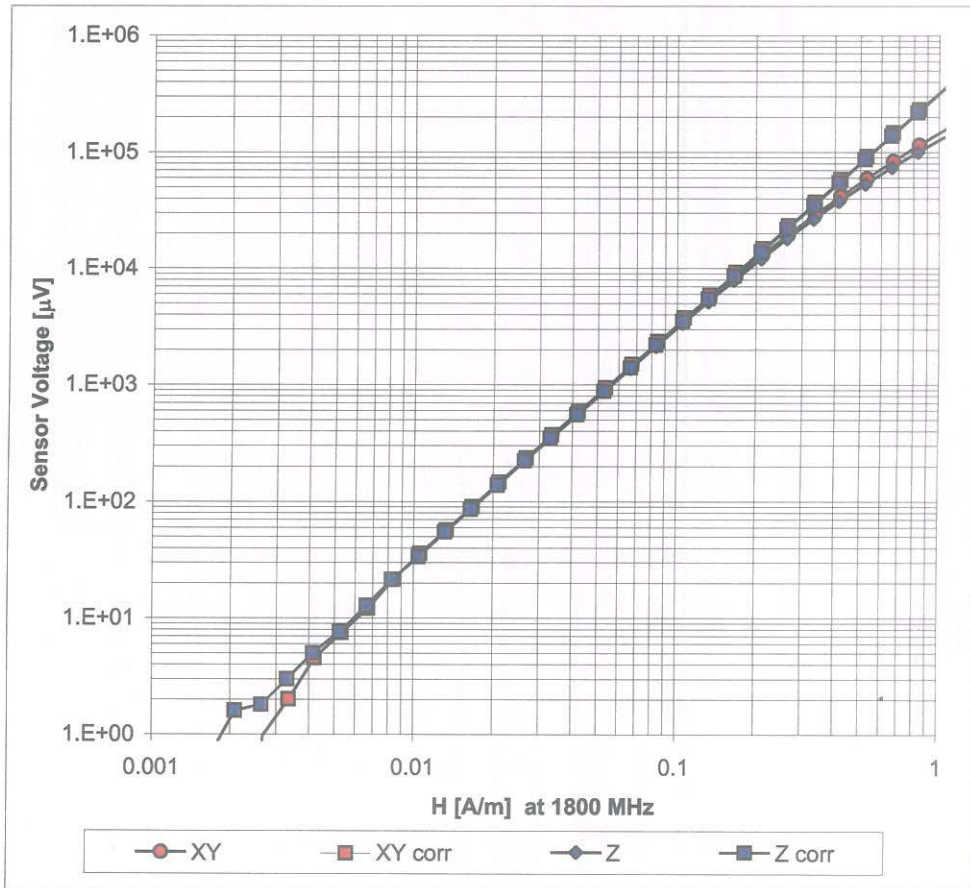
### Receiving Pattern ( $\phi$ ), $\vartheta = 0^\circ$



Uncertainty of Axial Isotropy Assessment:  $\pm 0.5\%$  (k=2)

## Dynamic Range f(H-field)

(Waveguide R22, f = 1800 MHz)



**Uncertainty of Linearity Assessment: ± 0.6% (k=2)**