



# FCC RF Test Report

**APPLICANT** : Samsung Electronics Co., Ltd.  
**EQUIPMENT** : Mobile Phone  
**BRAND NAME** : SAMSUNG  
**MODEL NAME** : SCH-P709E  
**FCC ID** : A3LSCHP709E  
**STANDARD** : FCC 47 CFR Part 2, 22(H), 24(E)  
**CLASSIFICATION** : PCS Licensed Transmitter Held to Ear (PCE)

The product was received on Jan. 08, 2014 and testing was completed on Feb. 13, 2014. We, SPORTON INTERNATIONAL (SHENZHEN) INC., would like to declare that the tested sample has been evaluated in accordance with the procedures given in ANSI / TIA / EIA-603-C-2004 and shown to be compliant with the applicable technical standards.

The test results in this report apply exclusively to the tested model / sample. Without written approval of SPORTON INTERNATIONAL (SHENZHEN) INC., the test report shall not be reproduced except in full.

Reviewed by: Joseph Lin / Supervisor

Approved by: Jones Tsai / Manager



Testing Laboratory  
2353

## **SPORTON INTERNATIONAL (SHENZHEN) INC.**

**No. 3 Building, the third floor of south, Shahe River west, Fengzeyuan warehouse, Nanshan District, Shenzhen, Guangdong, P.R.C.**



## TABLE OF CONTENTS

REVISION HISTORY.....	3
SUMMARY OF TEST RESULT .....	4
<b>1 GENERAL DESCRIPTION .....</b>	<b>5</b>
1.1 Applicant.....	5
1.2 Manufacturer .....	5
1.3 Feature of Equipment Under Test.....	5
1.4 Product Specification of Equipment Under Test .....	6
1.5 Modification of EUT .....	6
1.6 Maximum ERP/EIRP Power, Frequency Tolerance, and Emission Designator .....	7
1.7 Testing Site .....	8
1.8 Applied Standards .....	8
<b>2 TEST CONFIGURATION OF EQUIPMENT UNDER TEST.....</b>	<b>9</b>
2.1 Test Mode.....	9
2.2 Connection Diagram of Test System .....	11
2.3 Support Unit used in test configuration and system.....	11
2.4 Measurement Results Explanation Example .....	11
<b>3 TEST RESULT.....</b>	<b>12</b>
3.1 Conducted Output Power Measurement.....	12
3.2 Peak-to-Average Ratio .....	15
3.3 Effective Radiated Power and Effective Isotropic Radiated Power Measurement .....	27
3.4 99% Occupied Bandwidth and 26dB Bandwidth Measurement.....	34
3.5 Band Edge Measurement.....	61
3.6 Conducted Spurious Emission Measurement.....	78
3.7 Field Strength of Spurious Radiation Measurement .....	142
3.8 Frequency Stability Measurement.....	192
<b>4 LIST OF MEASURING EQUIPMENT .....</b>	<b>198</b>
<b>5 UNCERTAINTY OF EVALUATION .....</b>	<b>199</b>



### REVISION HISTORY

REPORT NO.	VERSION	DESCRIPTION	ISSUED DATE
FG410803	Rev. 01	Initial issue of report	Feb. 14, 2014

### SUMMARY OF TEST RESULT

Report Section	FCC Rule	Description	Limit	Result	Remark
3.1	§2.1046	Conducted Output Power	N/A	PASS	-
3.2	§24.232(d)	Peak-to-Average Ratio	< 13 dB	PASS	-
3.3	§22.913(a)(2)	Effective Radiated Power	< 7 Watts	PASS	-
3.3	§24.232(c)	Equivalent Isotropic Radiated Power	< 2 Watts	PASS	-
3.4	§2.1049 §22.917(a) §24.238(b)	Occupied Bandwidth	N/A	PASS	-
3.5	§2.1051 §22.917(a) §24.238(a)	Band Edge Measurement	< 43+10log <sub>10</sub> (P[Watts])	PASS	-
3.6	§2.1051 §22.917(a) §24.238(a)	Conducted Spurious Emission	< 43+10log <sub>10</sub> (P[Watts])	PASS	-
3.7	§2.1053 §22.917(a) §24.238(a)	Field Strength of Spurious Radiation	< 43+10log <sub>10</sub> (P[Watts])	PASS	Under limit 19.38 dB at 1672.000 MHz
3.8	§2.1055 §22.355 §24.235	Frequency Stability for Temperature & Voltage	< 2.5 ppm	PASS	-



# 1 General Description

## 1.1 Applicant

Samsung Electronics Co., Ltd.

A3 Building, No.185 Kexue Avenue, Science City, Guang Zhou, PRC

## 1.2 Manufacturer

Samsung Electronics Co., Ltd.

129, Samsung-ro, Yeongtong-gu, Suwon-city, Gyeonggi-do, 443-742, Korea

## 1.3 Feature of Equipment Under Test

Product Feature	
Equipment	Mobile Phone
Brand Name	SAMSUNG
Model Name	SCH-P709E
FCC ID	A3LSCHP709E
GSM Operating Band(s)	GSM 850/900/1800/1900MHz
GPRS / EGPRS Multi Slot Class	GPRS Class 10 , EGPRS Class 10
WCDMA Operating Band(s)	FDDI/FDDII/FDDV
Wi-Fi Specification	802.11b/g/n (HT20) 802.11a/n (HT20/HT40)
Bluetooth Version	Bluetooth v3.0+EDR, Bluetooth v4.0 LE
NFC Specification	Type A/B
HW Version	P709E.03
SW Version	P709EKEUAMK1
EUT Stage	Pre-Production

Remark: The above EUT's information was declared by manufacturer. Please refer to the specifications or user's manual for more detailed description.

### 1.4 Product Specification of Equipment Under Test

Product Specification subjective to this standard	
<b>Tx Frequency</b>	GSM850: 824.2 MHz ~ 848.8 MHz GSM1900: 1850.2 MHz ~ 1909.8MHz WCDMA Band V: 826.4 MHz ~ 846.6 MHz WCDMA Band II: 1852.4 MHz ~ 1907.6 MHz
<b>Rx Frequency</b>	GSM850: 869.2 MHz ~ 893.8 MHz GSM1900: 1930.2 MHz ~ 1989.8 MHz WCDMA Band V: 871.4 MHz ~ 891.6 MHz WCDMA Band II: 1932.4 MHz ~ 1987.6 MHz
<b>Maximum Output Power to Antenna</b>	SIM1 Card: GSM850 : 33.46 dBm GSM1900 : 30.90 dBm WCDMA Band V : 22.73 dBm WCDMA Band II : 22.80 dBm SIM2 Card: GSM1900 : 29.09 dBm
<b>Antenna Type</b>	LDS Antenna
<b>Type of Modulation</b>	GSM: GMSK GPRS: GMSK EDGE: GMSK / 8PSK WCDMA: QPSK (Uplink) HSDPA: QPSK (Uplink) HSUPA: QPSK (Uplink)

### 1.5 Modification of EUT

No modifications are made to the EUT during all test items.



### 1.6 Maximum ERP/EIRP Power, Frequency Tolerance, and Emission Designator

FCC Rule	System	Type of Modulation	Maximum ERP/EIRP (W)	Frequency Tolerance (ppm)	Emission Designator
<b>SIM1 Card</b>					
Part 22	GSM850 GSM	GMSK	0.33	0.03 ppm	244KGXW
Part 22	GSM850 EDGE class 8	8PSK	0.09	0.02 ppm	246KG7W
Part 22	WCDMA Band V RMC 12.2Kbps	QPSK	0.04	0.00 ppm	4M18F9W
Part 24	GSM1900 GSM	GMSK	1.06	0.02 ppm	248KGXW
Part 24	GSM1900 EDGE class 8	8PSK	0.49	0.02 ppm	248KG7W
Part 24	WCDMA Band II RMC 12.2Kbps	QPSK	0.19	0.01 ppm	4M18F9W
<b>SIM2 Card</b>					
Part 24	GSM1900 GSM	GMSK	0.61	0.01 ppm	248KGXW
Part 24	GSM1900 EDGE class 8	8PSK	0.32	0.01 ppm	248KG7W

## 1.7 Testing Site

<b>Test Site</b>	SPORTON INTERNATIONAL (SHENZHEN) INC.		
<b>Test Site Location</b>	No. 3 Building, the third floor of south, Shahe River west, Fengzeyuan warehouse, Nanshan District, Shenzhen, Guangdong, P.R.C. TEL: +86-755-3320-2398		
<b>Test Site No.</b>	<b>Sporton Site No.</b>		<b>FCC Registration No.</b>
	TH01-SZ	03CH01-SZ	831040

## 1.8 Applied Standards

According to the specifications of the manufacturer, the EUT must comply with the requirements of the following standards:

- ♦ FCC 47 CFR Part 2, 22(H), 24(E)
- ♦ ANSI / TIA / EIA-603-C-2004
- ♦ FCC KDB 971168 D01 Power Meas. License Digital Systems v02r01

**Remark:**

1. All test items were verified and recorded according to the standards and without any deviation during the test.
2. This EUT has also been tested and complied with the requirements of FCC Part 15, Subpart B, recorded in a separate test report.

## 2 Test Configuration of Equipment Under Test

### 2.1 Test Mode

During all testing, EUT is in link mode with base station emulator at maximum power level. The spurious emission measurements were carried out in semi-anechoic chamber with 3-meter test range, and EUT was rotated on three test planes to find out the worst emission.

Frequency range investigated for radiated emission is as follows:

1. 30 MHz to 9000 MHz for GSM850 and WCDMA Band V.
2. 30 MHz to 19000 MHz for GSM1900 and WCDMA Band II.

Test Modes		
Band	Radiated TCs	Conducted TCs
GSM 850	<ul style="list-style-type: none"> <li>■ GSM Link</li> <li>■ EDGE class 8 Link</li> </ul>	<ul style="list-style-type: none"> <li>■ GSM Link</li> <li>■ EDGE class 8 Link</li> </ul>
GSM 1900	<ul style="list-style-type: none"> <li>■ GSM Link</li> <li>■ EDGE class 8 Link</li> </ul>	<ul style="list-style-type: none"> <li>■ GSM Link</li> <li>■ EDGE class 8 Link</li> </ul>
WCDMA Band V	<ul style="list-style-type: none"> <li>■ RMC 12.2Kbps Link</li> </ul>	<ul style="list-style-type: none"> <li>■ RMC 12.2Kbps Link</li> </ul>
WCDMA Band II	<ul style="list-style-type: none"> <li>■ RMC 12.2Kbps Link</li> </ul>	<ul style="list-style-type: none"> <li>■ RMC 12.2Kbps Link</li> </ul>

**Note:**

1. The maximum power levels are GSM mode for GMSK link, EDGE multi-slot class 8 mode for 8PSK link, RMC 12.2Kbps mode for WCDMA band V, and RMC 12.2Kbps mode for WCDMA band II, only these modes were used for all tests.
2. Because there are individual antennas for each WWAN, WLAN, and Bluetooth, the co-location test modes are not required.
3. SIM1 Card supports GSM850, GSM1900, WCDMA Band V, and WCDMA Band II; SIM2 Card only supports GSM1900.



The conducted power tables are as follows:

SIM1 Card:

Conducted Power (*Unit: dBm)						
Band	GSM850			GSM1900		
Channel	128	189	251	512	661	810
Frequency	824.2	836.4	848.8	1850.2	1880.0	1909.8
GSM	33.28	33.34	33.46	30.86	30.50	30.90
GPRS class 8	33.26	33.21	33.38	30.83	30.43	30.88
GPRS class 10	28.74	28.79	28.77	26.95	26.34	26.96
EGPRS class 8	27.31	27.35	27.36	26.62	26.08	26.65
EGPRS class 10	27.28	27.29	27.33	26.49	25.98	26.56

Conducted Power (*Unit: dBm)						
Band	WCDMA Band V			WCDMA Band II		
Channel	4132	4182	4233	9262	9400	9538
Frequency	826.4	836.4	846.6	1852.4	1880.0	1907.6
AMR 12.2K	22.57	22.70	22.63	22.60	22.68	22.79
RMC 12.2K	22.59	22.73	22.65	22.62	22.71	22.80
HSDPA Subtest-1	21.14	21.25	21.26	21.16	21.24	21.38
HSDPA Subtest-2	21.13	21.24	21.17	21.17	21.22	21.39
HSDPA Subtest-3	21.14	21.26	21.18	21.19	21.42	21.41
HSDPA Subtest-4	21.13	21.24	21.17	21.16	21.50	21.39
HSUPA Subtest-1	20.78	20.84	21.41	20.90	21.36	20.96
HSUPA Subtest-2	20.66	20.77	20.61	20.71	20.70	21.00
HSUPA Subtest-3	20.46	20.13	20.11	20.28	20.15	20.38
HSUPA Subtest-4	21.38	21.23	21.06	21.16	21.42	21.24
HSUPA Subtest-5	20.56	20.83	20.77	20.56	20.58	20.13

SIM2 Card:

Conducted Power (*Unit: dBm)			
Band	GSM1900		
Channel	512	661	810
Frequency	1850.2	1880.0	1909.8
GSM	28.98	28.54	29.09
GPRS class 8	28.92	28.53	29.06
GPRS class 10	26.72	26.27	26.75
EGPRS class 8	26.31	25.92	26.36
EGPRS class 10	26.16	25.79	26.33

## 2.2 Connection Diagram of Test System

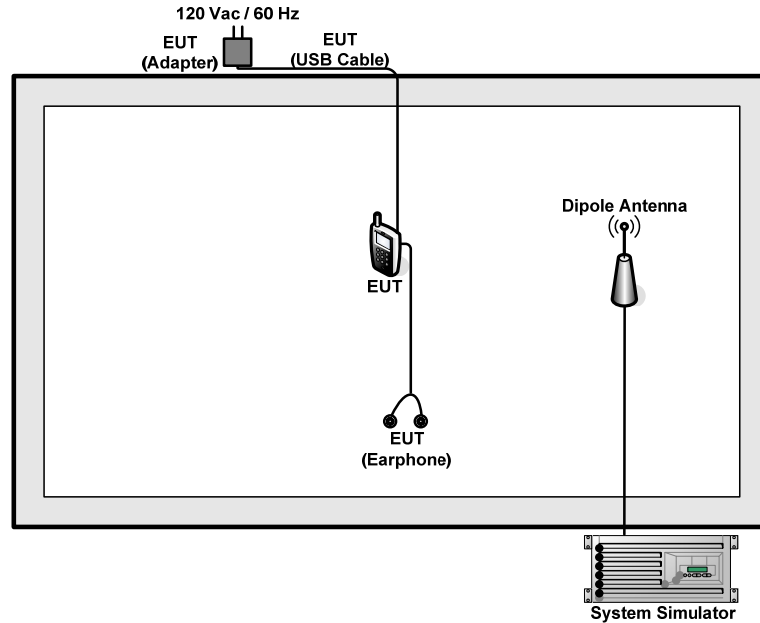

## 2.3 Support Unit used in test configuration and system

Item	Equipment	Trade Name	Model No.	FCC ID	Data Cable	Power Cord
1.	System Simulator	R&S	CMU 200	N/A	N/A	Unshielded, 1.8 m

## 2.4 Measurement Results Explanation Example

### For all conducted test items:

The offset level is set in the spectrum analyzer to compensate the RF cable loss and attenuator factor between EUT conducted output port and spectrum analyzer. With the offset compensation, the spectrum analyzer reading level is exactly the EUT RF output level.

The spectrum analyzer offset is derived from RF cable loss and attenuator factor.

*Offset = RF cable loss + attenuator factor.*

Following shows an offset computation example with cable loss 4.2 dB and 10dB attenuator.

Example :

$$\begin{aligned} \text{Offset(dB)} &= \text{RF cable loss(dB)} + \text{attenuator factor(dB)} \\ &= 4.2 + 10 = 14.2 \text{ (dB)} \end{aligned}$$

### 3 Test Result

#### 3.1 Conducted Output Power Measurement

##### 3.1.1 Description of the Conducted Output Power Measurement

A base station simulator was used to establish communication with the EUT. Its parameters were set to transmit the maximum power on the EUT. The measured power in the radio frequency on the transmitter output terminals shall be reported.

##### 3.1.2 Measuring Instruments

The measuring equipment is listed in the section 4 of this test report.

##### 3.1.3 Test Procedures

1. The transmitter output port was connected to base station.
2. Set EUT at maximum power through base station.
3. Select lowest, middle, and highest channels for each band and different modulation.
4. Measure the maximum burst average power for GSM and maximum average power for other modulation signal.

##### 3.1.4 Test Setup

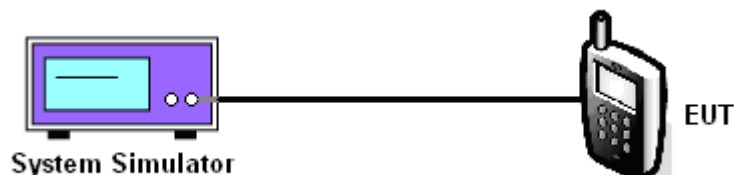

### 3.1.5 Test Result of Conducted Output Power

SIM1 Card:

Cellular Band									
Modes	GSM850 (GSM)			GSM850 (EDGE class 8)			WCDMA Band V (RMC 12.2Kbps)		
Channel	128 (Low)	189 (Mid)	251 (High)	128 (Low)	189 (Mid)	251 (High)	4132 (Low)	4182 (Mid)	4233 (High)
Frequency (MHz)	824.2	836.4	848.8	824.2	836.4	848.8	826.4	836.4	846.6
Conducted Power (dBm)	33.28	33.34	33.46	27.31	27.35	27.36	22.59	22.73	22.65
Conducted Power (Watts)	2.13	2.16	2.22	0.54	0.54	0.54	0.18	0.19	0.18

PCS Band									
Modes	GSM1900 (GSM)			GSM1900 (EDGE class 8)			WCDMA Band II (RMC 12.2Kbps)		
Channel	512 (Low)	661 (Mid)	810 (High)	512 (Low)	661 (Mid)	810 (High)	9262 (Low)	9400 (Mid)	9538 (High)
Frequency (MHz)	1850.2	1880	1909.8	1850.2	1880	1909.8	1852.4	1880	1907.6
Conducted Power (dBm)	30.86	30.50	30.90	26.62	26.08	26.65	22.62	22.71	22.80
Conducted Power (Watts)	1.22	1.12	1.23	0.46	0.41	0.46	0.18	0.19	0.19

**Note:** maximum burst average power for GSM, and maximum average power for WCDMA.



SIM2 Card:

PCS Band						
Modes	GSM1900 (GSM)			GSM1900 (EDGE class 8)		
Channel	512 (Low)	661 (Mid)	810 (High)	512 (Low)	661 (Mid)	810 (High)
Frequency (MHz)	1850.2	1880	1909.8	1850.2	1880	1909.8
Conducted Power (dBm)	28.98	28.54	29.09	26.31	25.92	26.36
Conducted Power (Watts)	0.79	0.71	0.81	0.43	0.39	0.43

Note: maximum burst average power for GSM.

## 3.2 Peak-to-Average Ratio

### 3.2.1 Description of the PAR Measurement

The peak-to-average ratio (PAR) of the transmission may not exceed 13 dB.

### 3.2.2 Measuring Instruments

The measuring equipment is listed in the section 4 of this test report.

### 3.2.3 Test Procedures

1. The EUT was connected to Spectrum Analyzer and System Simulator via power divider.
2. For GSM/EGPRS operating modes:
  - a. Set EUT in maximum power output.
  - b. Set the RBW = 1MHz, VBW = 3MHz, Peak detector in spectrum analyzer for first trace.
  - c. Set the RBW = 1MHz, VBW = 3MHz, RMS detector in spectrum analyzer for second trace.
  - d. The wanted burst signal is triggered by spectrum analyzer, and measured respectively the peak level and Mean level without burst-off time, after system simulator synchronized with the spectrum analyzer.
3. For UMTS operating modes:
  - a. Set the CCDF (Complementary Cumulative Distribution Function) option in spectrum analyzer.
  - b. The highest RF powers were measured and recorded the maximum PAPR level associated with a probability of 0.1 %.
4. Record the deviation as Peak to Average Ratio.

### 3.2.4 Test Setup

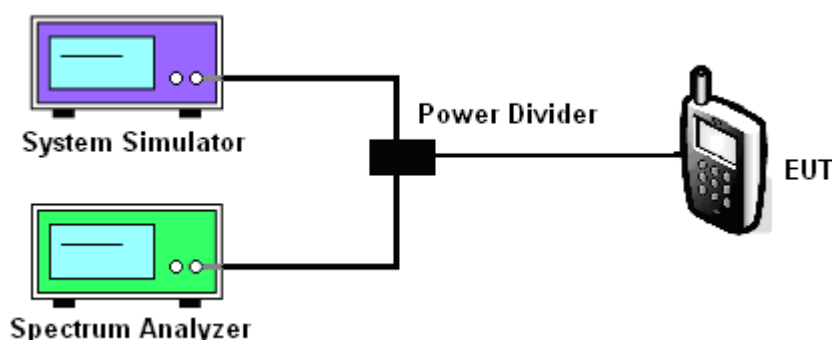

### 3.2.5 Test Result of Peak-to-Average Ratio

SIM1 Card:

PCS Band									
Modes	GSM1900 (GSM)			GSM1900 (EDGE class 8)			WCDMA Band II (RMC 12.2Kbps)		
Channel	512 (Low)	661 (Mid)	810 (High)	512 (Low)	661 (Mid)	810 (High)	9262 (Low)	9400 (Mid)	9538 (High)
Frequency (MHz)	1850.2	1880	1909.8	1850.2	1880	1909.8	1852.4	1880	1907.6
Peak-to-Average Ratio (dB)	0.40	0.42	0.43	2.70	2.93	3.00	3.16	3.12	3.00

SIM2 Card:

PCS Band						
Modes	GSM1900 (GSM)			GSM1900 (EDGE class 8)		
Channel	512 (Low)	661 (Mid)	810 (High)	512 (Low)	661 (Mid)	810 (High)
Frequency (MHz)	1850.2	1880	1909.8	1850.2	1880	1909.8
Peak-to-Average Ratio (dB)	0.40	0.42	0.40	2.92	2.75	2.74



### 3.2.6 Test Result (Plots) of Peak-to-Average Ratio

SIM1 Card:

Band :	GSM 1900	Test Mode :	GSM Link (GMSK)
--------	----------	-------------	-----------------

Peak-to-Average Ratio on Channel 512 (1850.2 MHz)



Date: 13.JAN.2014 04:38:50

Peak-to-Average Ratio on Channel 661 (1880.0 MHz)



Date: 13.JAN.2014 04:37:44



Peak-to-Average Ratio on Channel 810 (1909.8 MHz)



Date: 13.JAN.2014 04:40:11



Band :	GSM 1900	Test Mode :	EDGE class 8 Link (8PSK)
--------	----------	-------------	--------------------------

Peak-to-Average Ratio on Channel 512 (1850.2 MHz)

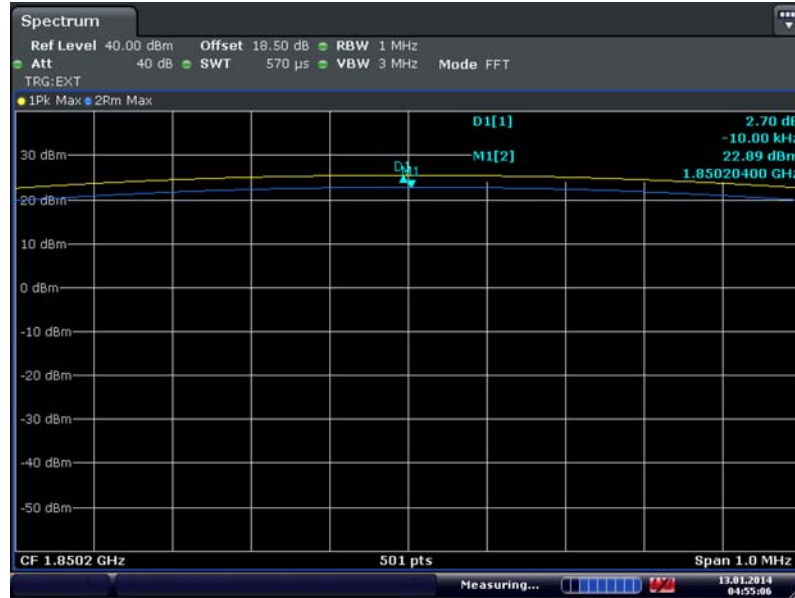

Date: 13.JAN.2014 04:55:05

Peak-to-Average Ratio on Channel 661 (1880.0 MHz)

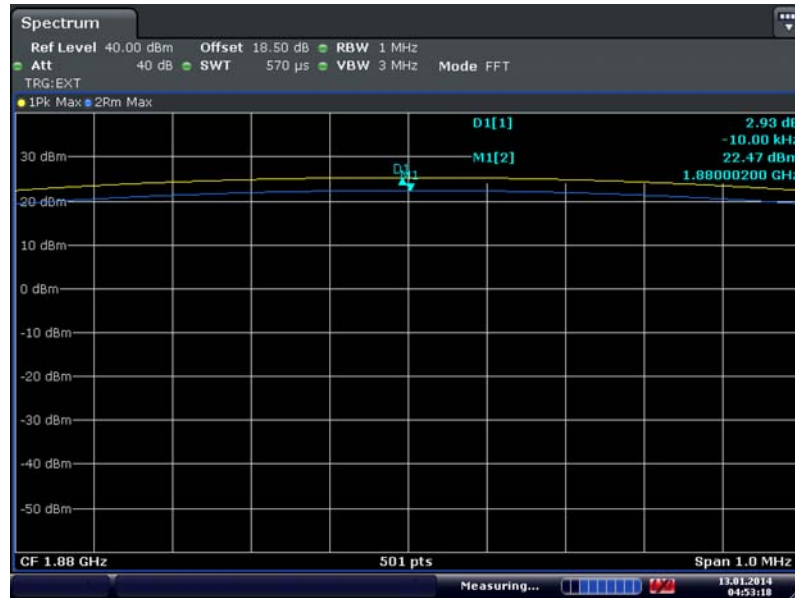

Date: 13.JAN.2014 04:53:18



Peak-to-Average Ratio on Channel 810 (1909.8 MHz)

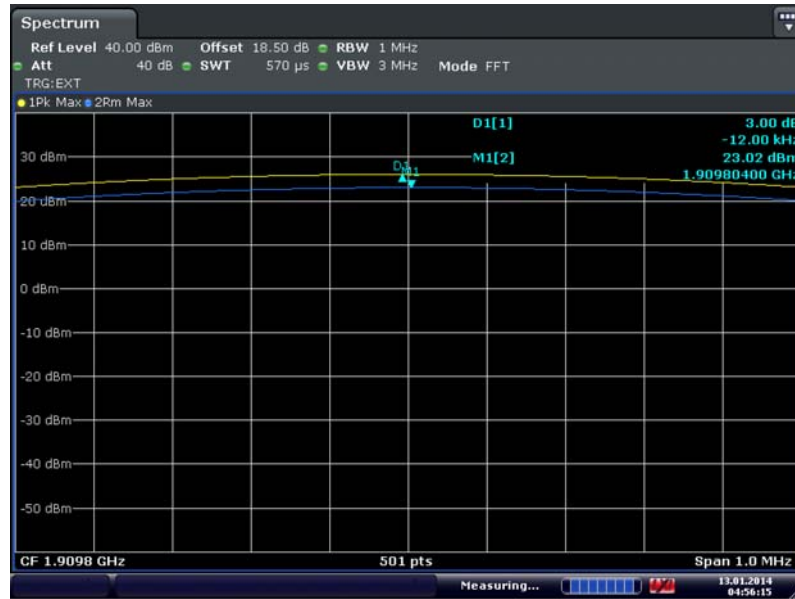

Date: 13.JAN.2014 04:56:14



<b>Band :</b>	WCDMA Band II	<b>Test Mode :</b>	RMC 12.2Kbps Link (QPSK)
---------------	---------------	--------------------	--------------------------

Peak-to-Average Ratio on Channel 9262 (1852.4 MHz)

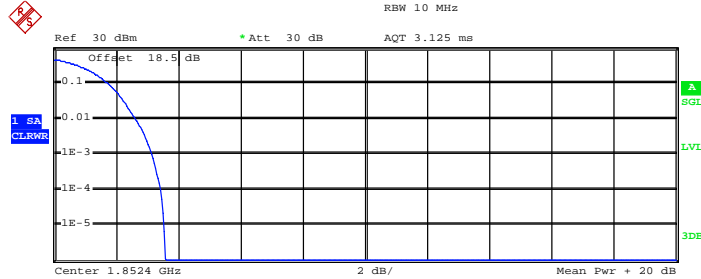

Complementary Cumulative Distribution Function (100000 samples)

Trace 1  
 Mean 21.43 dBm  
 Peak 25.03 dBm  
 Crest 3.60 dB

10 % 1.76 dB  
 1 % 2.64 dB  
 .1 % 3.16 dB  
 .01 % 3.44 dB

Date: 12.JAN.2014 15:01:51

Peak-to-Average Ratio on Channel 9400 (1880.0 MHz)

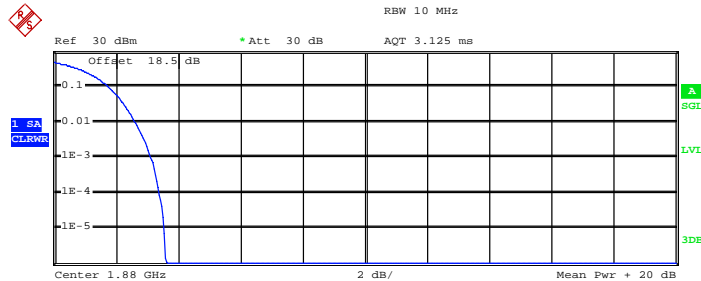

Complementary Cumulative Distribution Function (100000 samples)

Trace 1  
 Mean 21.57 dBm  
 Peak 25.17 dBm  
 Crest 3.60 dB

10 % 1.76 dB  
 1 % 2.64 dB  
 .1 % 3.12 dB  
 .01 % 3.40 dB

Date: 12.JAN.2014 15:02:59



Peak-to-Average Ratio on Channel 9538 (1907.6 MHz)

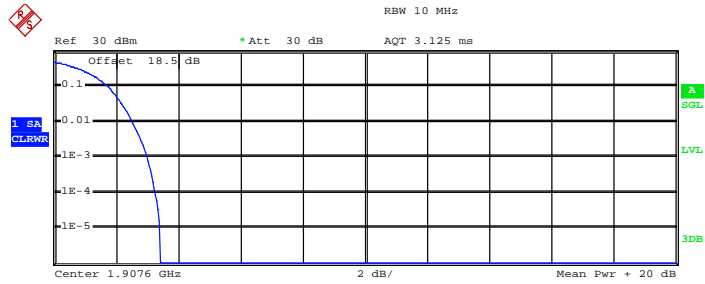

Complementary Cumulative Distribution Function (100000 samples)

Trace 1  
 Mean 21.67 dBm  
 Peak 25.10 dBm  
 Crest 3.43 dB

10 %	1.76 dB
1 %	2.52 dB
.1 %	3.00 dB
.01 %	3.28 dB

Date: 12.JAN.2014 15:02:32



SIM2 Card:

Band :	GSM 1900	Test Mode :	GSM Link (GMSK)
--------	----------	-------------	-----------------

Peak-to-Average Ratio on Channel 512 (1850.2 MHz)

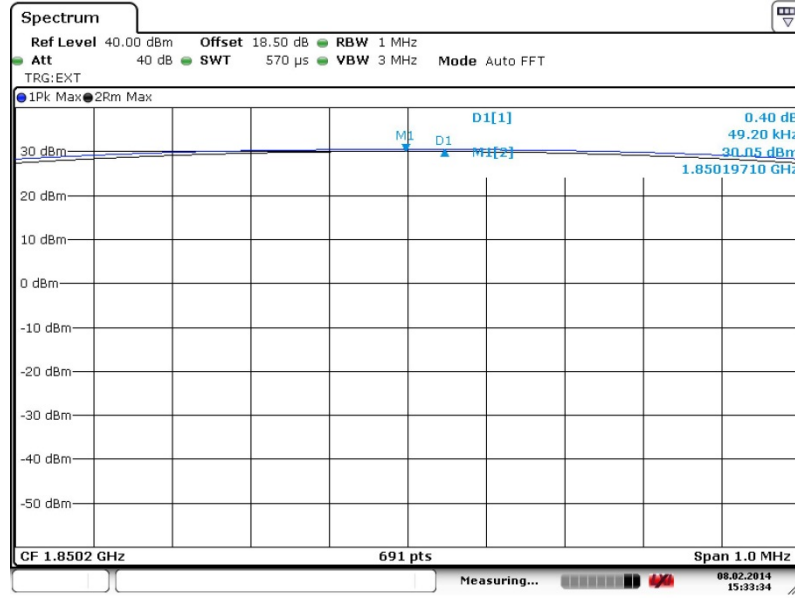

Date: 8.FEB.2014 15:33:35

Peak-to-Average Ratio on Channel 661 (1880.0 MHz)

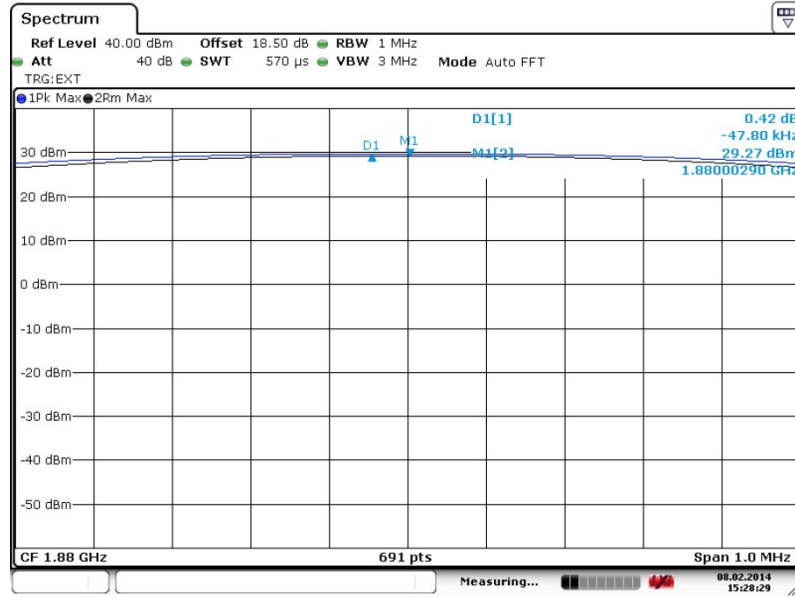

Date: 8.FEB.2014 15:28:30



Peak-to-Average Ratio on Channel 810 (1909.8 MHz)

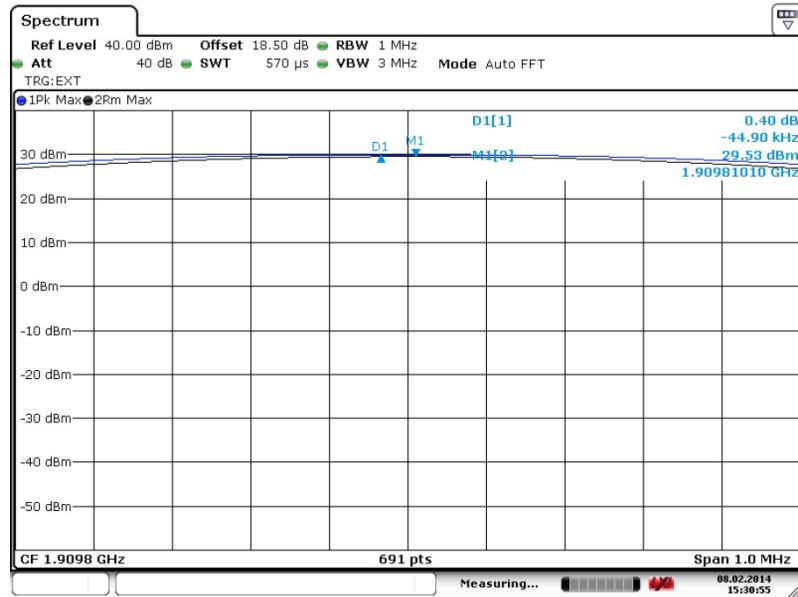

Date: 8.FEB.2014 15:30:56



Band :	GSM 1900	Test Mode :	EDGE class 8 Link (8PSK)
--------	----------	-------------	--------------------------

Peak-to-Average Ratio on Channel 512 (1850.2 MHz)

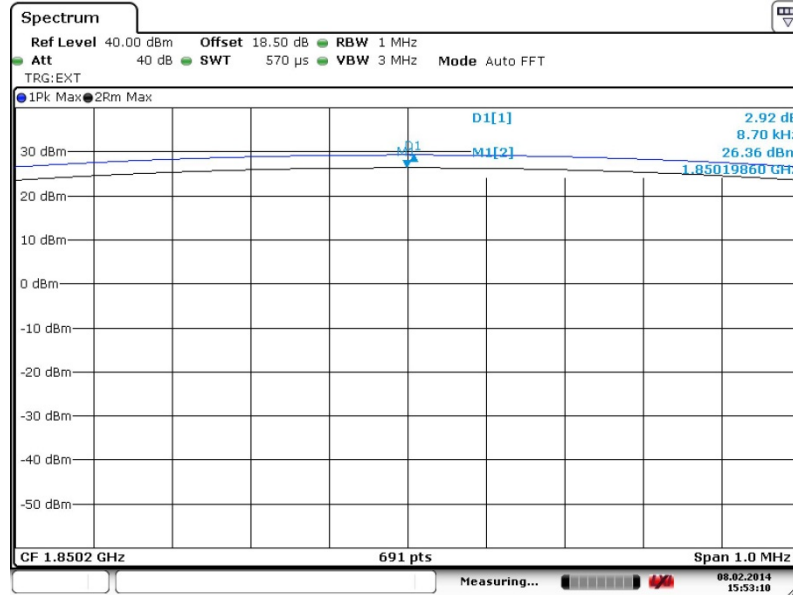

Date: 8.FEB.2014 15:53:11

Peak-to-Average Ratio on Channel 661 (1880.0 MHz)

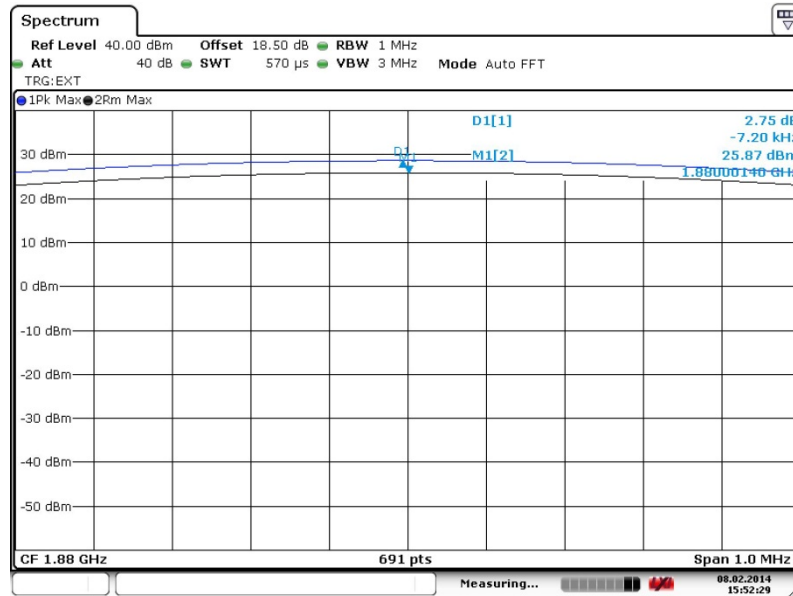

Date: 8.FEB.2014 15:52:29



Peak-to-Average Ratio on Channel 810 (1909.8 MHz)

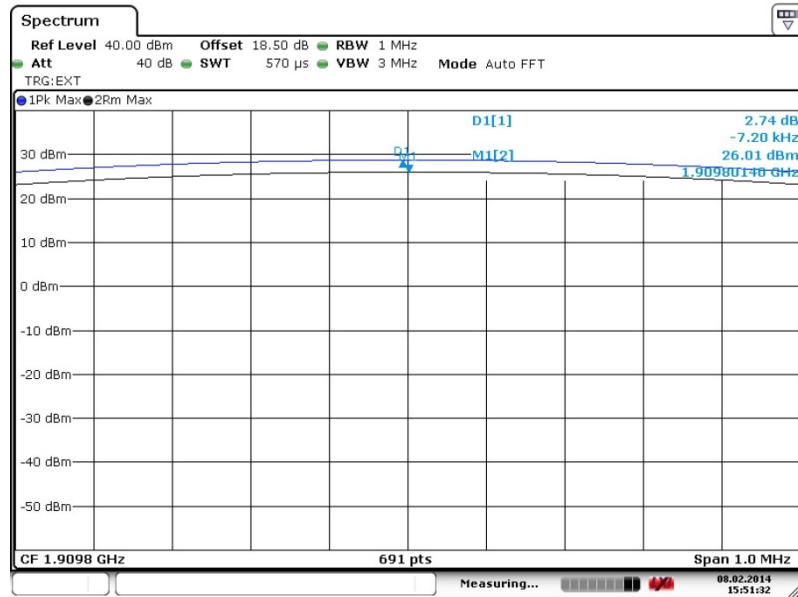

Date: 8.FEB.2014 15:51:32

### 3.3 Effective Radiated Power and Effective Isotropic Radiated Power Measurement

#### 3.3.1 Description of the ERP/EIRP Measurement

The substitution method, in ANSI / TIA / EIA-603-C-2004, was used for ERP/EIRP measurement, and the spectrum analyzer configuration follows KDB 971168 D01 Power Meas. License Digital Systems v02r01. The ERP of mobile transmitters must not exceed 7 Watts and the EIRP of mobile transmitters are limited to 2 Watts.

#### 3.3.2 Measuring Instruments

The measuring equipment is listed in the section 4 of this test report.

#### 3.3.3 Test Procedures

1. The EUT was placed on a non-conductive rotating platform with 0.8 meter height in a semi-anechoic chamber. The radiated emission at the fundamental frequency was measured at 3 m with a test antenna and a spectrum analyzer with RBW= 1MHz, VBW= 3MHz for GSM, RBW= 100 kHz, VBW= 300 kHz, used channel power option with bandwidth=5MHz for WCDMA, and RMS detector settings per KDB 971168 D01.
2. During the measurement, the EUT was enforced in maximum power and linked with a base station. The highest emission was recorded from analyzer power level (LVL) from the 360 degrees rotation of the turntable and the test antenna raised and lowered over a range from 1 to 4 meters in both horizontally and vertically polarized orientations.
3. Effective Isotropic Radiated Power (EIRP) was measured by substitution method according to TIA/EIA-603-C. The EUT was replaced by dipole antenna (substitution antenna) at same location, and then a known power from S.G. was applied into the dipole antenna through a Tx cable, and then recorded the maximum Analyzer reading through raised and lowered the test antenna. The correction factor (in dB) = S.G. - Tx Cable loss + Substitution antenna gain - Analyzer reading. Then the EUT's EIRP was calculated with the correction factor,  $EIRP = LVL + \text{Correction factor}$  and  $ERP = EIRP - 2.15$ .

### 3.3.4 Test Setup

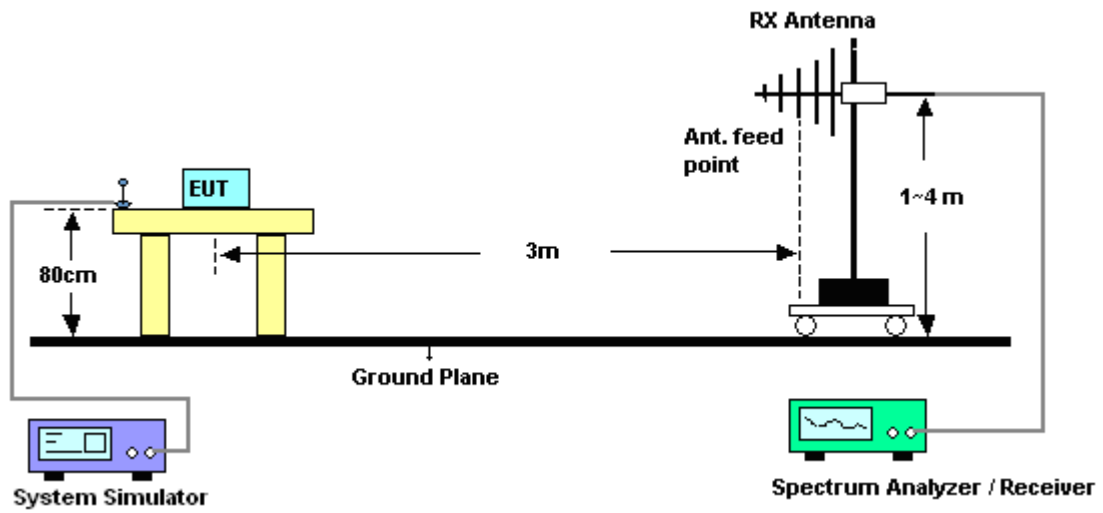

### 3.3.5 Test Result of ERP

SIM1 Card:

GSM850 (GSM) Radiated Power ERP				
Horizontal Polarization				
Frequency (MHz)	LVL (dBm)	Correction Factor (dB)	ERP (dBm)	ERP (W)
824.2	-2.74	28.798	23.91	0.25
836.4	-2.61	28.577	23.82	0.24
848.8	-2.96	28.064	22.95	0.20
Vertical Polarization				
Frequency (MHz)	LVL (dBm)	Correction Factor (dB)	ERP (dBm)	ERP (W)
824.2	-5.25	32.596	25.20	0.33
836.4	-5.01	31.952	24.79	0.30
848.8	-5.05	31.561	24.36	0.27

\* ERP = LVL (dBm) + Correction Factor (dB) – 2.15

GSM850 (EDGE class 8) Radiated Power ERP				
Horizontal Polarization				
Frequency (MHz)	LVL (dBm)	Correction Factor (dB)	ERP (dBm)	ERP (W)
824.2	-8.11	28.798	18.54	0.07
836.4	-7.86	28.577	18.57	0.07
848.8	-8.52	28.064	17.39	0.05
Vertical Polarization				
Frequency (MHz)	LVL (dBm)	Correction Factor (dB)	ERP (dBm)	ERP (W)
824.2	-11.05	32.596	19.40	0.09
836.4	-10.39	31.952	19.41	0.09
848.8	-9.96	31.561	19.45	0.09

\* ERP = LVL (dBm) + Correction Factor (dB) – 2.15



WCDMA Band V (RMC 12.2Kbps) Radiated Power ERP				
Horizontal Polarization				
Frequency (MHz)	LVL (dBm)	Correction Factor (dB)	ERP (dBm)	ERP (W)
826.4	-11.50	28.945	15.30	0.03
836.4	-10.34	28.577	16.09	0.04
846.6	-11.26	28.051	14.64	0.03
Vertical Polarization				
Frequency (MHz)	LVL (dBm)	Correction Factor (dB)	ERP (dBm)	ERP (W)
826.4	-14.92	32.594	15.52	0.04
836.4	-13.54	31.952	16.26	0.04
846.6	-14.14	31.684	15.39	0.03

\* ERP = LVL (dBm) + Correction Factor (dB) – 2.15

**3.3.6 Test Result of EIRP**
**SIM1 Card:**

<b>GSM1900 (GSM) Radiated Power EIRP</b>				
Horizontal Polarization				
<b>Frequency (MHz)</b>	<b>LVL (dBm)</b>	<b>Correction Factor (dB)</b>	<b>EIRP (dBm)</b>	<b>EIRP (W)</b>
1850.2	-15.27	45.43	30.16	1.04
1880.0	-16.19	45.62	29.43	0.88
1909.8	-16.14	46.40	30.26	1.06
Vertical Polarization				
<b>Frequency (MHz)</b>	<b>LVL (dBm)</b>	<b>Correction Factor (dB)</b>	<b>EIRP (dBm)</b>	<b>EIRP (W)</b>
1850.2	-18.96	46.77	27.81	0.60
1880.0	-19.58	46.82	27.24	0.53
1909.8	-18.24	47.11	28.87	0.77

\* EIRP = LVL (dBm) + Correction Factor (dB)

<b>GSM1900 (EDGE class 8) Radiated Power EIRP</b>				
Horizontal Polarization				
<b>Frequency (MHz)</b>	<b>LVL (dBm)</b>	<b>Correction Factor (dB)</b>	<b>EIRP (dBm)</b>	<b>EIRP (W)</b>
1850.2	-18.54	45.43	26.89	0.49
1880.0	-20.10	45.62	25.52	0.36
1909.8	-19.89	46.40	26.51	0.45
Vertical Polarization				
<b>Frequency (MHz)</b>	<b>LVL (dBm)</b>	<b>Correction Factor (dB)</b>	<b>EIRP (dBm)</b>	<b>EIRP (W)</b>
1850.2	-22.57	46.77	24.20	0.26
1880.0	-23.43	46.82	23.39	0.22
1909.8	-22.98	47.11	24.13	0.26

\* EIRP = LVL (dBm) + Correction Factor (dB)



WCDMA Band II (RMC 12.2Kbps) Radiated Power EIRP				
Horizontal Polarization				
Frequency (MHz)	LVL (dBm)	Correction Factor (dB)	EIRP (dBm)	EIRP (W)
1852.4	-22.95	45.47	22.52	0.18
1880.0	-22.95	45.62	22.67	0.18
1907.6	-23.64	46.36	22.72	0.19
Vertical Polarization				
Frequency (MHz)	LVL (dBm)	Correction Factor (dB)	EIRP (dBm)	EIRP (W)
1852.4	-26.11	46.77	20.66	0.12
1880.0	-27.12	46.82	19.70	0.09
1907.6	-26.99	47.07	20.08	0.10

\* EIRP = LVL (dBm) + Correction Factor (dB)

**SIM2 Card:**

<b>GSM1900 (GSM) Radiated Power EIRP</b>				
Horizontal Polarization				
<b>Frequency (MHz)</b>	<b>LVL (dBm)</b>	<b>Correction Factor (dB)</b>	<b>EIRP (dBm)</b>	<b>EIRP (W)</b>
1850.2	-18.24	45.43	27.19	0.52
1880.0	-18.74	45.62	26.88	0.49
1909.8	-19.14	46.40	27.26	0.53
Vertical Polarization				
<b>Frequency (MHz)</b>	<b>LVL (dBm)</b>	<b>Correction Factor (dB)</b>	<b>EIRP (dBm)</b>	<b>EIRP (W)</b>
1850.2	-18.93	46.77	27.84	0.61
1880.0	-19.72	46.82	27.10	0.51
1909.8	-19.39	47.11	27.72	0.59

\* EIRP = LVL (dBm) + Correction Factor (dB)

<b>GSM1900 (EDGE class 8) Radiated Power EIRP</b>				
Horizontal Polarization				
<b>Frequency (MHz)</b>	<b>LVL (dBm)</b>	<b>Correction Factor (dB)</b>	<b>EIRP (dBm)</b>	<b>EIRP (W)</b>
1850.2	-20.80	45.43	24.63	0.29
1880.0	-21.49	45.62	24.13	0.26
1909.8	-21.44	46.40	24.96	0.31
Vertical Polarization				
<b>Frequency (MHz)</b>	<b>LVL (dBm)</b>	<b>Correction Factor (dB)</b>	<b>EIRP (dBm)</b>	<b>EIRP (W)</b>
1850.2	-21.74	46.77	25.03	0.32
1880.0	-22.84	46.82	23.98	0.25
1909.8	-22.64	47.11	24.47	0.28

\* EIRP = LVL (dBm) + Correction Factor (dB)

## 3.4 99% Occupied Bandwidth and 26dB Bandwidth Measurement

### 3.4.1 Description of 99% Occupied Bandwidth and 26dB Bandwidth Measurement

The 99% occupied bandwidth is the width of a frequency band such that, below the lower and above the upper frequency limits, the mean powers emitted are each equal to a specified percentage 0.5% of the total mean transmitted power.

The emission bandwidth is defined as the width of the signal between two points, located at the 2 sides of the carrier frequency, outside of which all emissions are attenuated at least 26 dB below the transmitter power.

### 3.4.2 Measuring Instruments

The measuring equipment is listed in the section 4 of this test report.

### 3.4.3 Test Procedures

1. The EUT was connected to Spectrum Analyzer and Base Station via power divider.
2. The RF output of EUT was connected to the spectrum analyzer by RF cable and attenuator. The path loss was compensated to the results for each measurement.
3. The 99% occupied bandwidth were measured, set RBW= 1% of span, VBW= 3\*RBW, sample detector, trace maximum hold.
4. The 26dB bandwidth were measured, set RBW= 1% of EBW, VBW= 3\*RBW, peak detector, trace maximum hold.

### 3.4.4 Test Setup

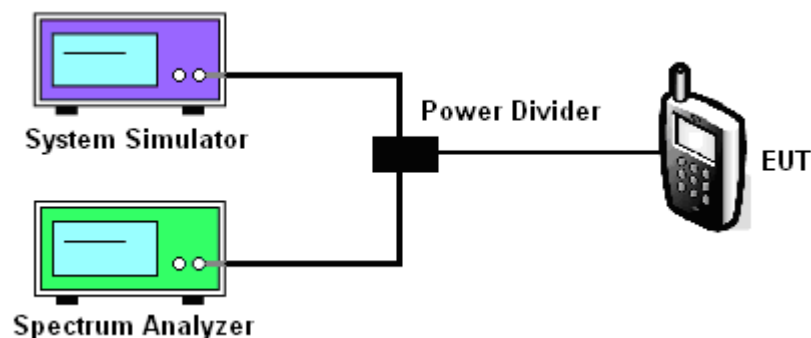

3.4.5 Test Result of Occupied Bandwidth and 26dB Bandwidth

SIM1 Card:

Cellular Band						
Modes	GSM850 (GSM)			GSM850 (EDGE class 8)		
Channel	128 (Low)	189 (Mid)	251 (High)	128 (Low)	189 (Mid)	251 (High)
Frequency (MHz)	824.2	836.4	848.8	824.2	836.4	848.8
99% OBW (kHz)	242.00	244.00	244.00	244.00	244.00	246.00
26dB BW (kHz)	314.00	312.00	314.00	304.00	306.00	308.00

PCS Band						
Modes	GSM1900 (GSM)			GSM1900 (EDGE class 8)		
Channel	512 (Low)	661 (Mid)	810 (High)	512 (Low)	661 (Mid)	810 (High)
Frequency (MHz)	1850.2	1880	1909.8	1850.2	1880	1909.8
99% OBW (kHz)	248.00	244.00	244.00	244.00	246.00	248.00
26dB BW (kHz)	312.00	312.00	310.00	308.00	308.00	306.00

Cellular Band			
Modes	WCDMA Band V (RMC 12.2Kbps)		
Channel	4132 (Low)	4182 (Mid)	4233 (High)
Frequency (MHz)	826.4	836.4	846.6
99% OBW (MHz)	4.18	4.18	4.18
26dB BW (MHz)	4.78	4.76	4.76

PCS Band			
Modes	WCDMA Band II (RMC 12.2Kbps)		
Channel	9262 (Low)	9400 (Mid)	9538 (High)
Frequency (MHz)	1852.4	1880	1907.6
99% OBW (MHz)	4.18	4.16	4.18
26dB BW (MHz)	4.78	4.74	4.76



SIM2 Card:

PCS Band						
Modes	GSM1900 (GSM)			GSM1900 (EDGE class 8)		
Channel	512 (Low)	661 (Mid)	810 (High)	512 (Low)	661 (Mid)	810 (High)
Frequency (MHz)	1850.2	1880	1909.8	1850.2	1880	1909.8
99% OBW (kHz)	248.00	242.00	244.00	246.00	248.00	244.00
26dB BW (kHz)	312.00	312.00	312.00	300.00	308.00	304.00



### 3.4.6 Test Result (Plots) of Occupied Bandwidth and 26dB Bandwidth

SIM1 Card:

Band :	GSM 850	Test Mode :	GSM Link (GMSK)
--------	---------	-------------	-----------------

99% Occupied Bandwidth Plot on Channel 128 (824.2 MHz)

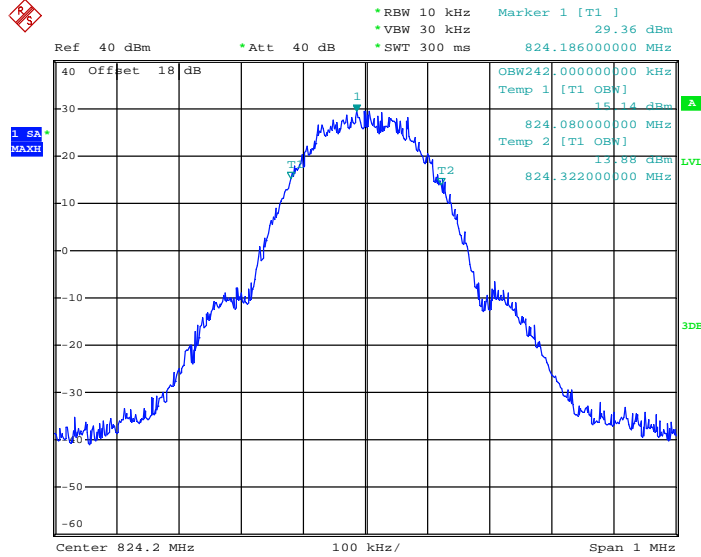

Date: 12.JAN.2014 09:45:30

26dB Bandwidth Plot on Channel 128 (824.2 MHz)

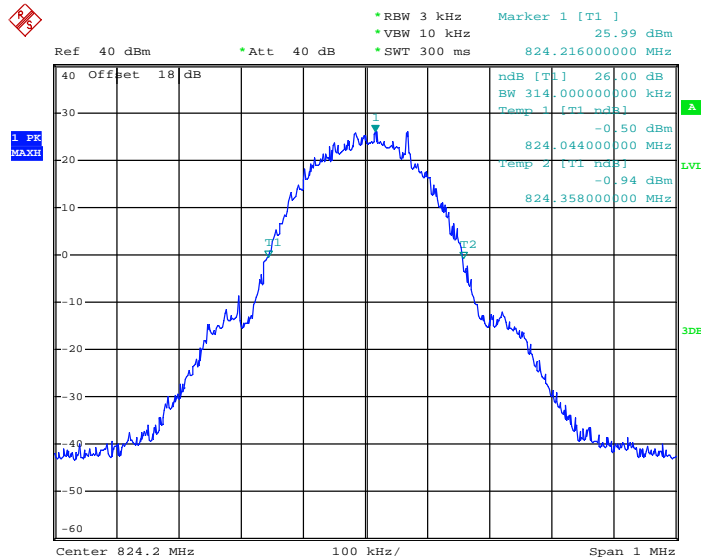

Date: 12.JAN.2014 09:30:30



### 99% Occupied Bandwidth Plot on Channel 189 (836.4 MHz)

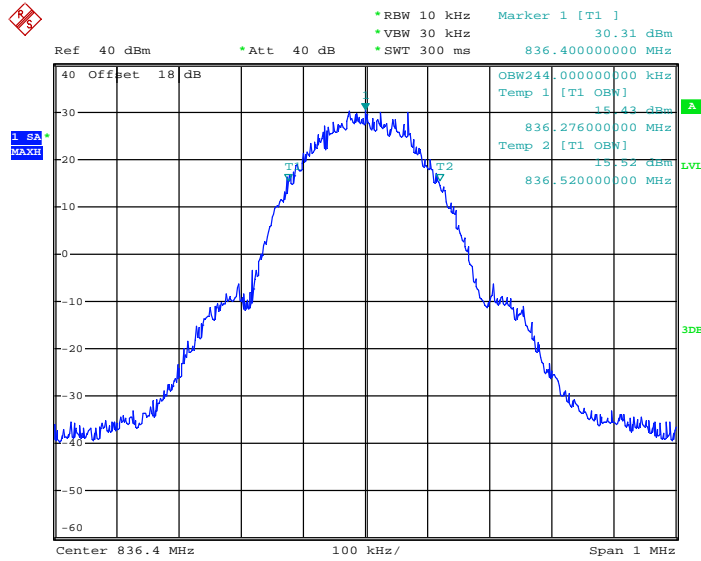

Date: 12.JAN.2014 09:41:27

### 26dB Bandwidth Plot on Channel 189 (836.4 MHz)

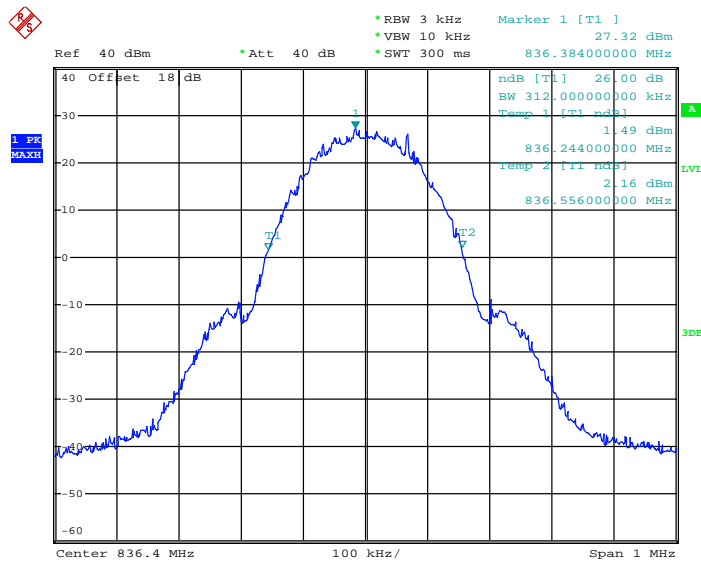

Date: 12.JAN.2014 09:28:44



99% Occupied Bandwidth Plot on Channel 251 (848.8 MHz)

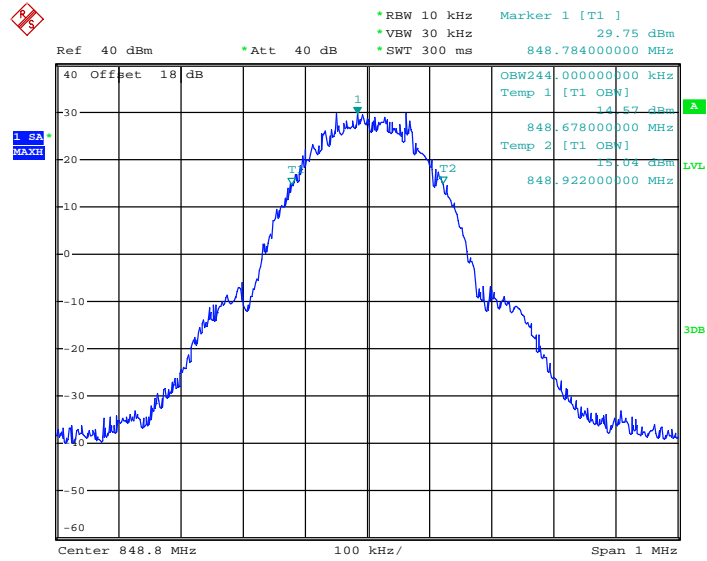

Date: 12.JAN.2014 09:43:33

26dB Bandwidth Plot on Channel 251 (848.8 MHz)

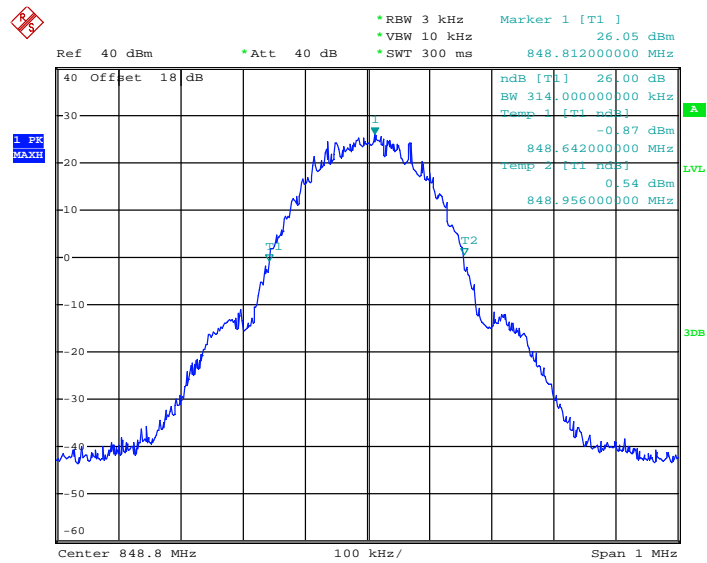

Date: 12.JAN.2014 09:33:03



<b>Band :</b>	GSM 850	<b>Test Mode :</b>	EDGE class 8 Link (8PSK)
---------------	---------	--------------------	--------------------------

99% Occupied Bandwidth Plot on Channel 128 (824.2 MHz)

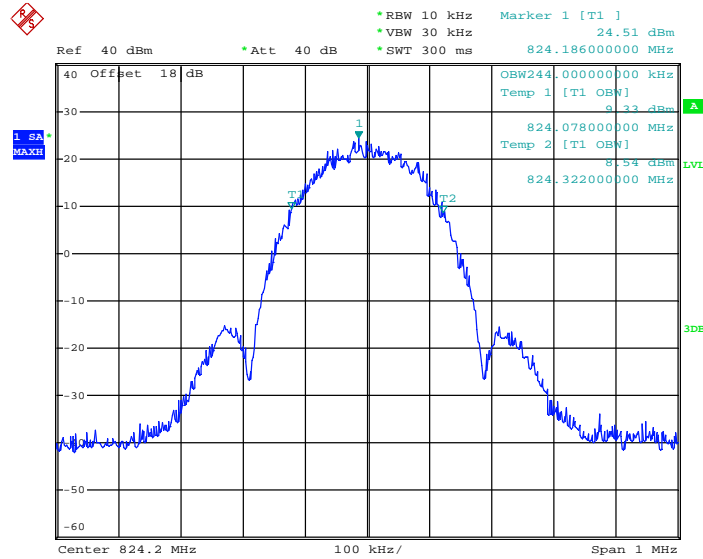

Date: 12.JAN.2014 13:17:17

26dB Bandwidth Plot on Channel 128 (824.2 MHz)

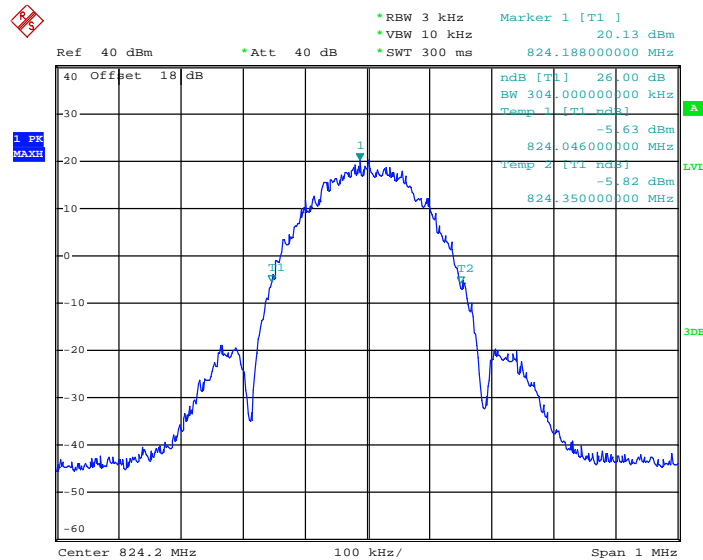

Date: 12.JAN.2014 13:07:25



### 99% Occupied Bandwidth Plot on Channel 189 (836.4 MHz)

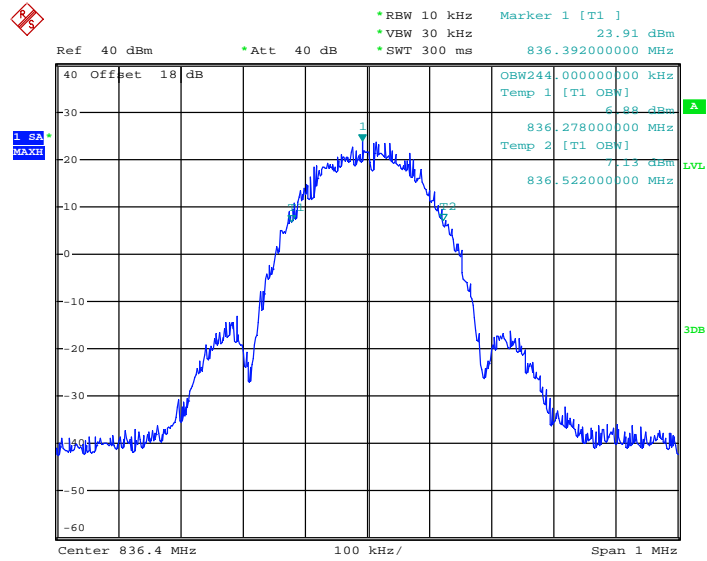

Date: 12.JAN.2014 13:14:39

### 26dB Bandwidth Plot on Channel 189 (836.4 MHz)

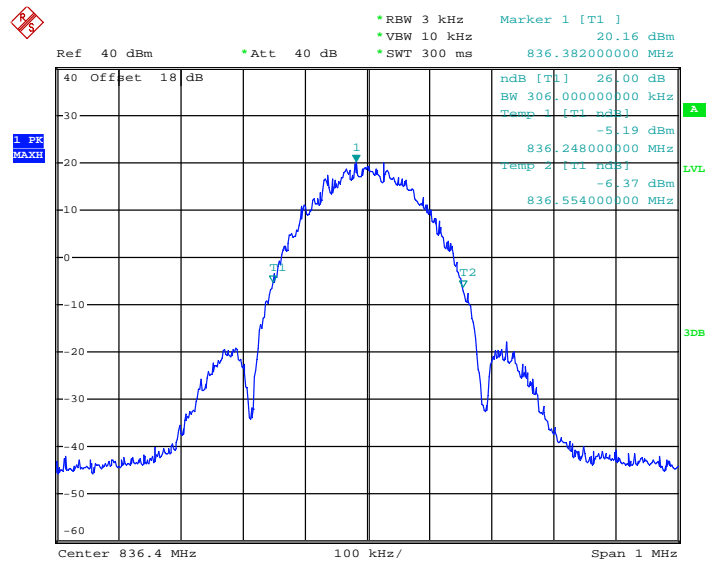

Date: 12.JAN.2014 13:09:15



### 99% Occupied Bandwidth Plot on Channel 251 (848.8 MHz)

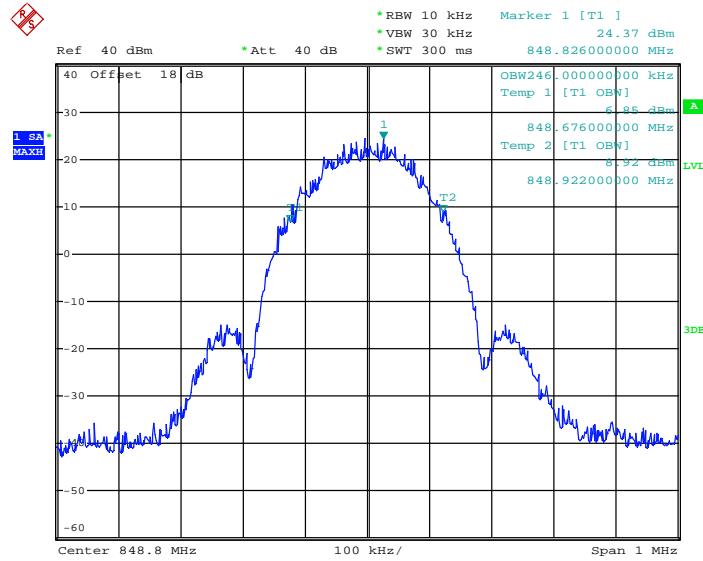

Date: 12.JAN.2014 13:13:05

### 26dB Bandwidth Plot on Channel 251 (848.8 MHz)

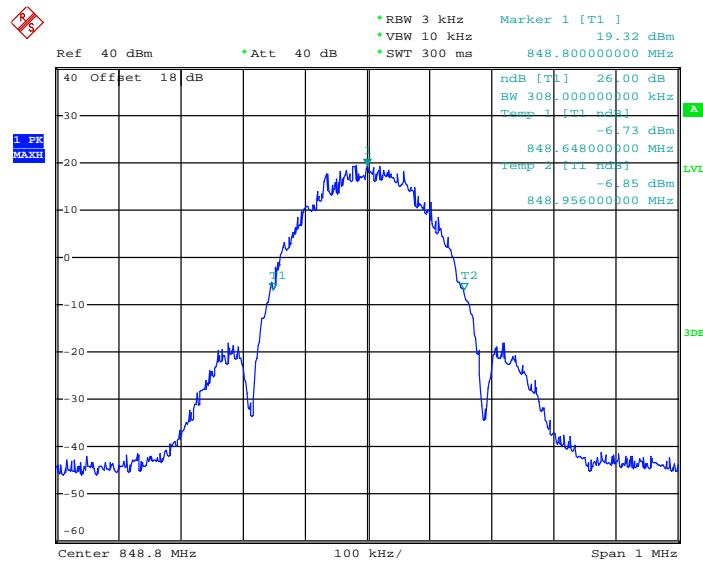

Date: 12.JAN.2014 13:10:51



Band :	GSM 1900	Test Mode :	GSM Link (GMSK)
--------	----------	-------------	-----------------

99% Occupied Bandwidth Plot on Channel 512 (1850.2 MHz)

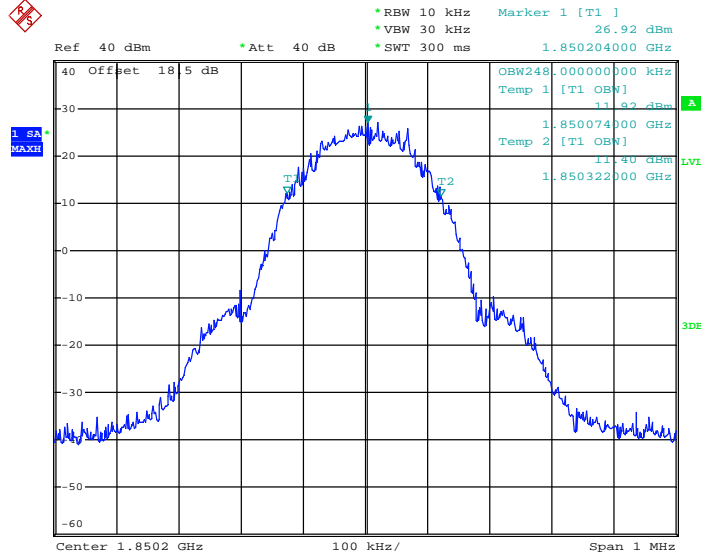

Date: 12.JAN.2014 11:40:10

26dB Bandwidth Plot on Channel 512 (1850.2 MHz)

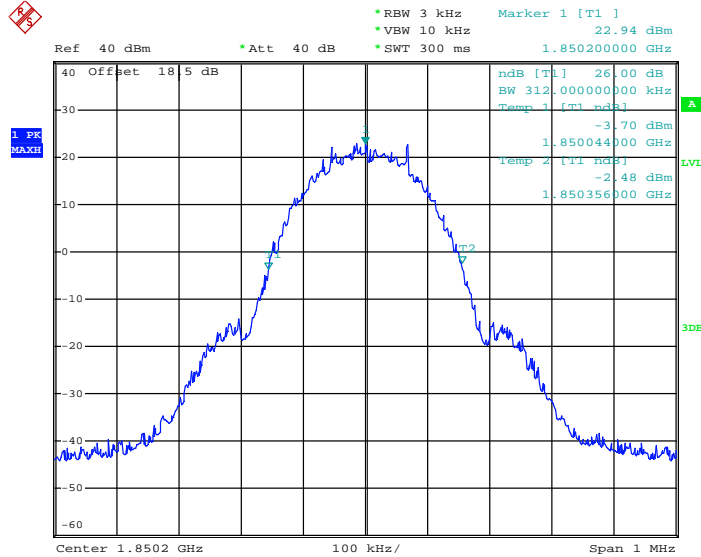

Date: 12.JAN.2014 11:28:28



99% Occupied Bandwidth Plot on Channel 661 (1880.0 MHz)

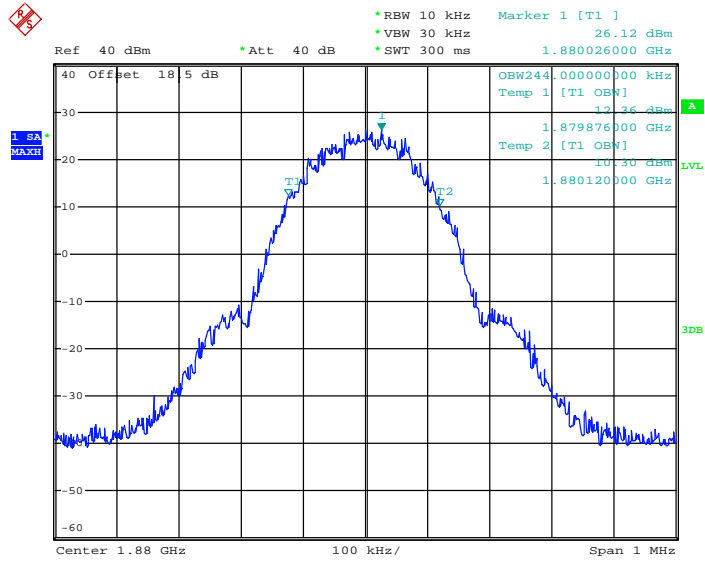

Date: 12.JAN.2014 11:37:22

26dB Bandwidth Plot on Channel 661 (1880.0 MHz)

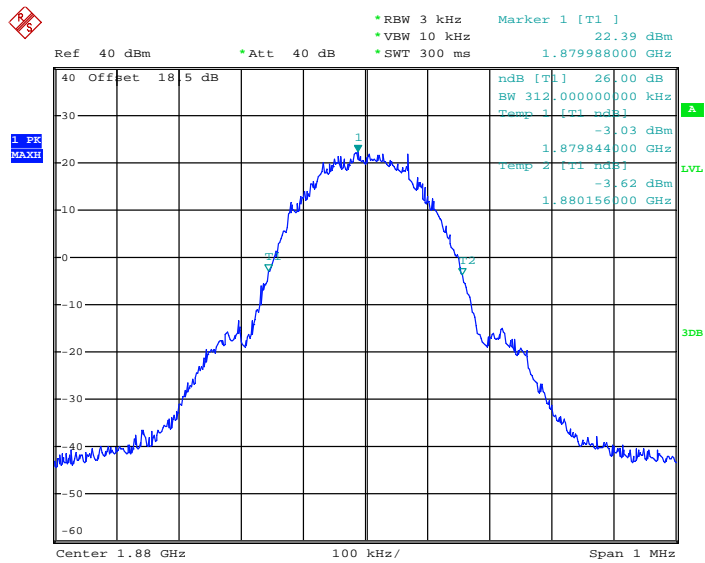

Date: 12.JAN.2014 11:30:55



99% Occupied Bandwidth Plot on Channel 810 (1909.8 MHz)

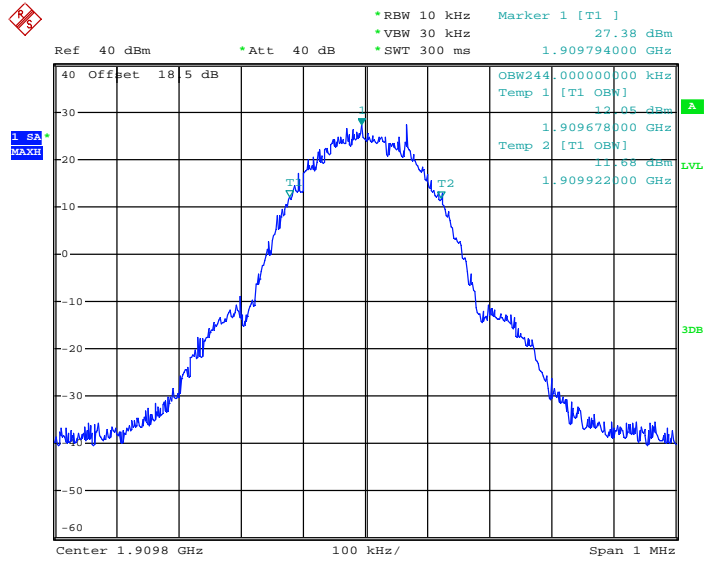

Date: 12.JAN.2014 11:35:37

26dB Bandwidth Plot on Channel 810 (1909.8 MHz)

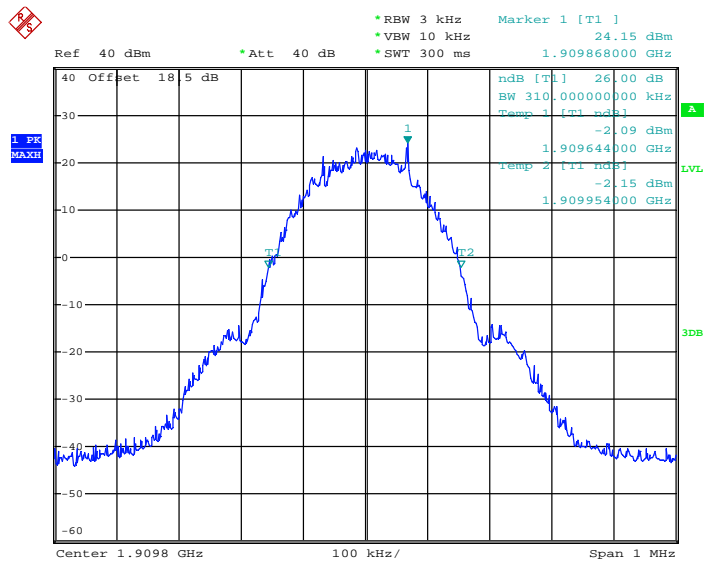

Date: 12.JAN.2014 11:32:42





99% Occupied Bandwidth Plot on Channel 661 (1880.0 MHz)

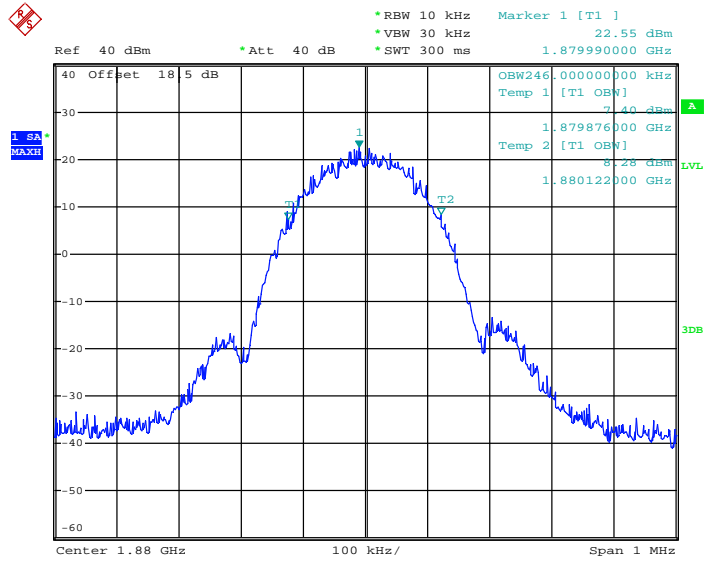

Date: 12.JAN.2014 12:04:42

26dB Bandwidth Plot on Channel 661 (1880.0 MHz)

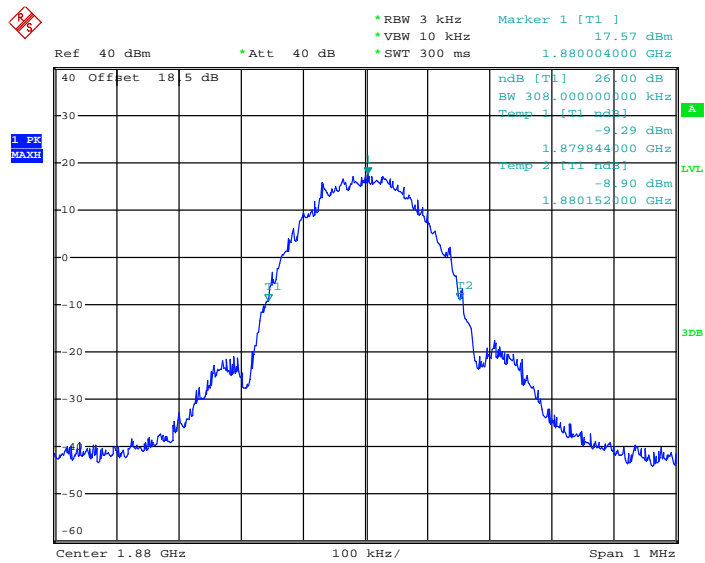

Date: 12.JAN.2014 13:32:05



99% Occupied Bandwidth Plot on Channel 810 (1909.8 MHz)

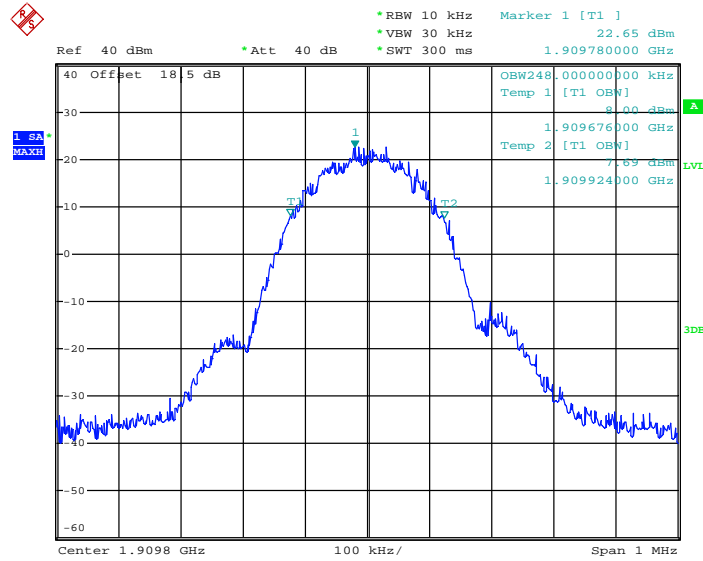

Date: 12.JAN.2014 12:07:28

26dB Bandwidth Plot on Channel 810 (1909.8 MHz)

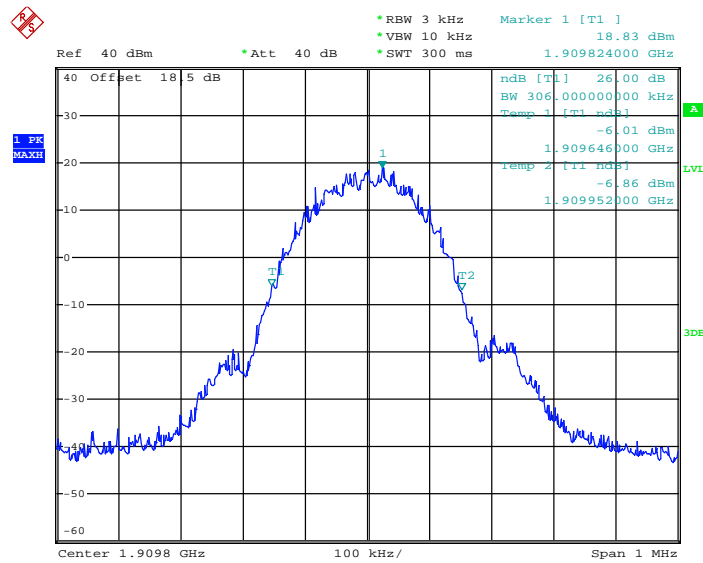

Date: 12.JAN.2014 13:35:42



<b>Band :</b>	WCDMA Band V	<b>Test Mode :</b>	RMC 12.2Kbps Link (QPSK)
---------------	--------------	--------------------	--------------------------

99% Occupied Bandwidth Plot on Channel 4132 (826.4 MHz)

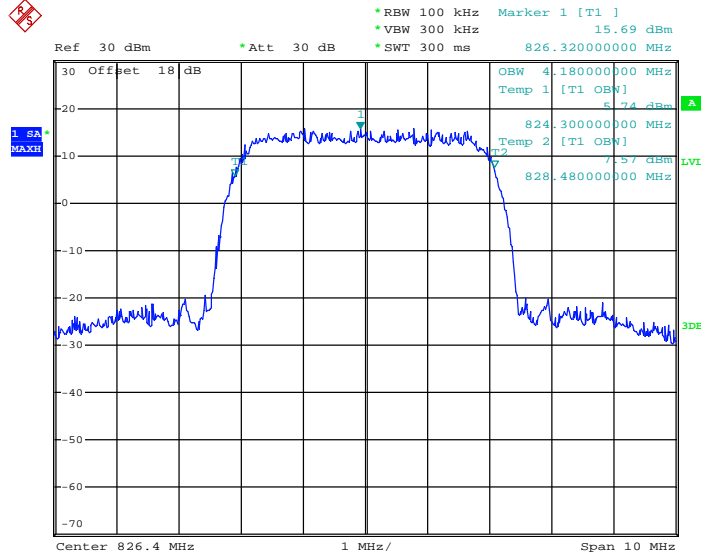

Date: 12.JAN.2014 13:54:53

26dB Bandwidth Plot on Channel 4132 (826.4 MHz)

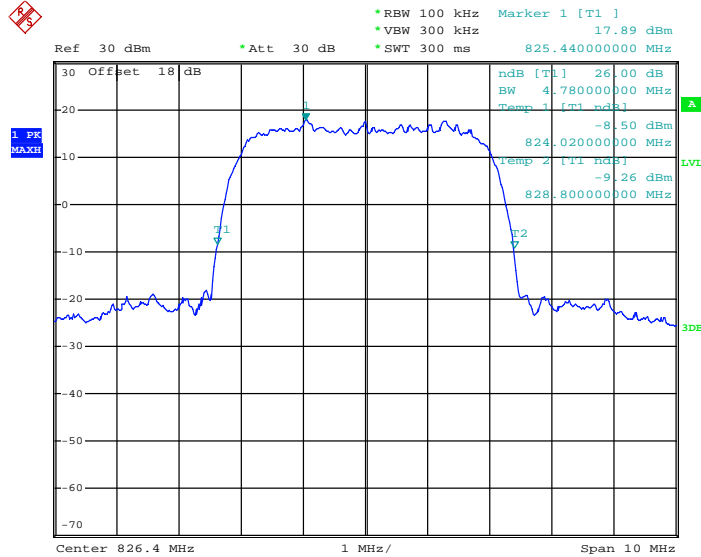

Date: 12.JAN.2014 13:49:29



99% Occupied Bandwidth Plot on Channel 4182 (836.4 MHz)

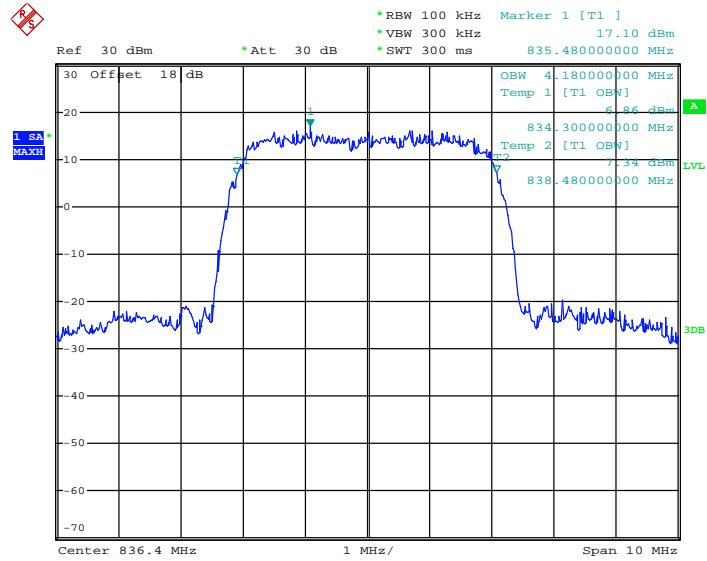

Date: 12.JAN.2014 13:53:29

26dB Bandwidth Plot on Channel 4182 (836.4 MHz)

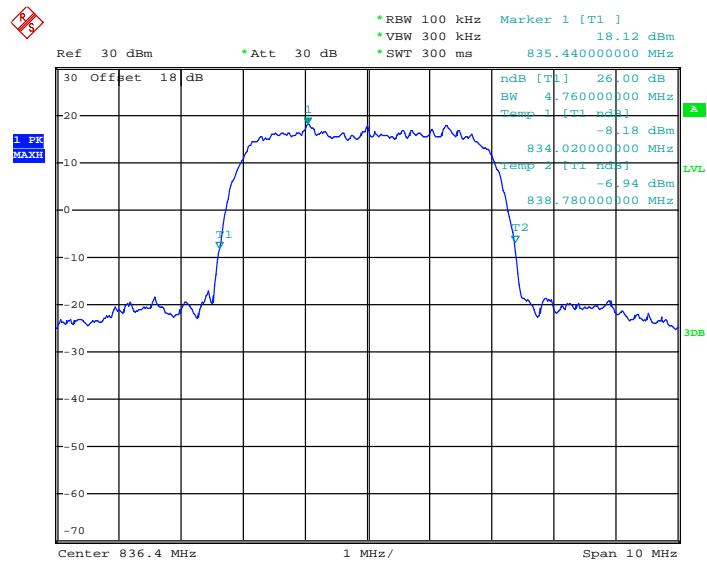

Date: 12.JAN.2014 13:47:29



99% Occupied Bandwidth Plot on Channel 4233 (846.6 MHz)

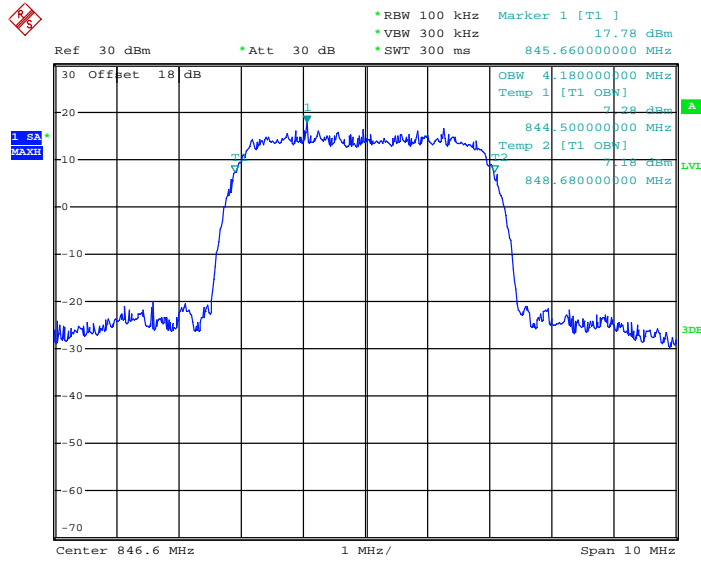

Date: 12.JAN.2014 13:52:06

26dB Bandwidth Plot on Channel 4233 (846.6 MHz)

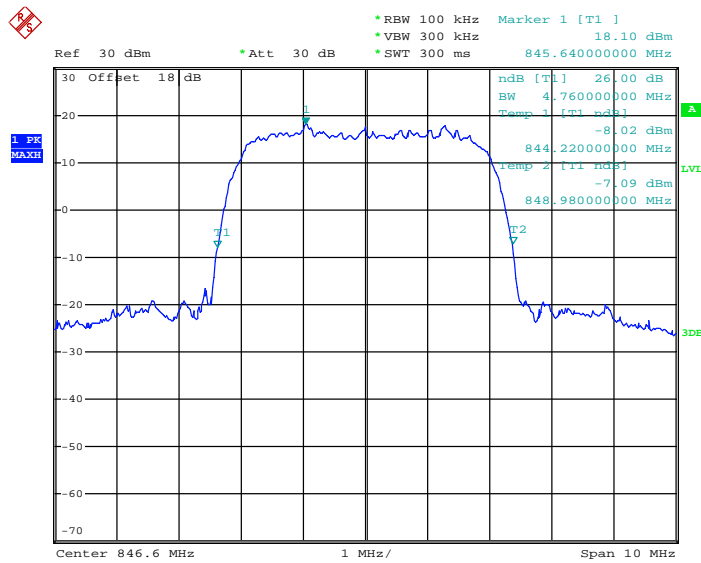

Date: 12.JAN.2014 13:50:18



Band :	WCDMA Band II	Test Mode :	RMC 12.2Kbps Link (QPSK)
--------	---------------	-------------	--------------------------

99% Occupied Bandwidth Plot on Channel 9262 (1852.4 MHz)

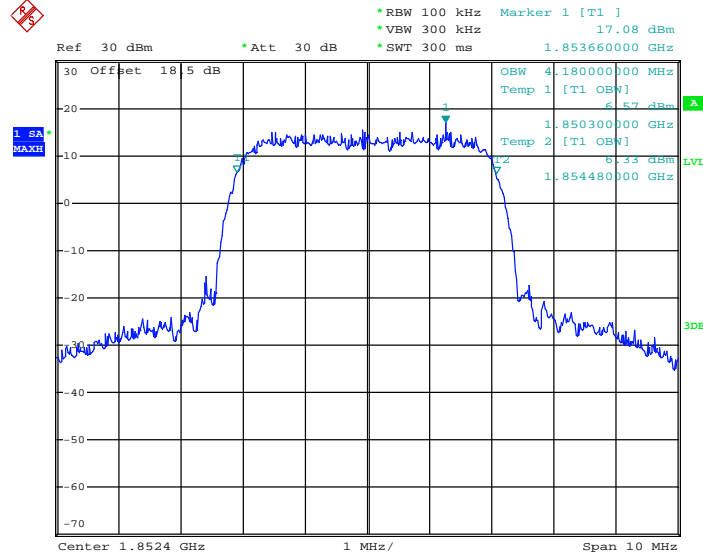

Date: 12.JAN.2014 14:50:44

26dB Bandwidth Plot on Channel 9262 (1852.4 MHz)

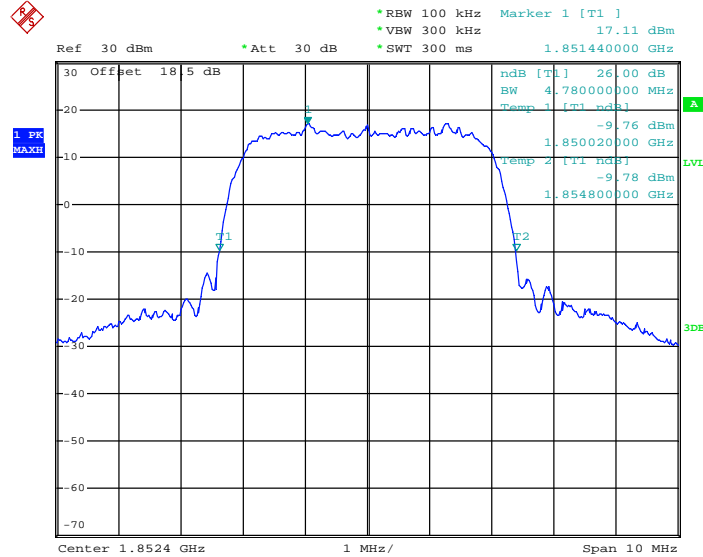

Date: 12.JAN.2014 14:44:04



99% Occupied Bandwidth Plot on Channel 9400 (1880.0 MHz)

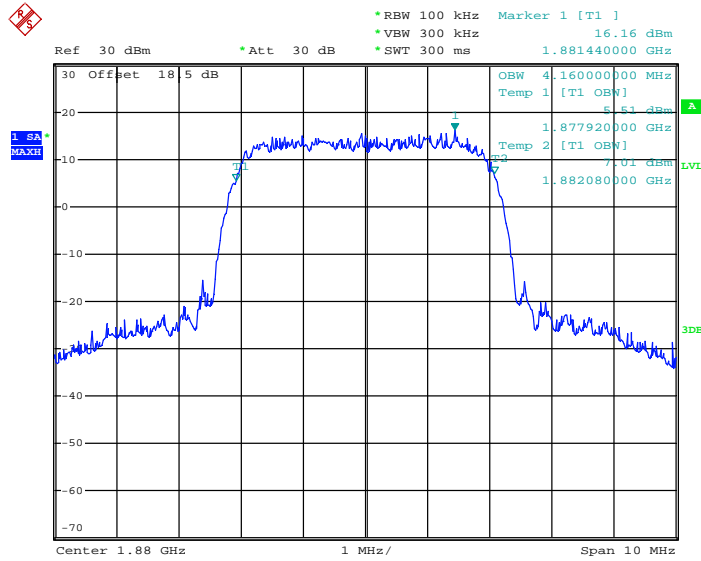

Date: 12.JAN.2014 14:49:17

26dB Bandwidth Plot on Channel 9400 (1880.0 MHz)

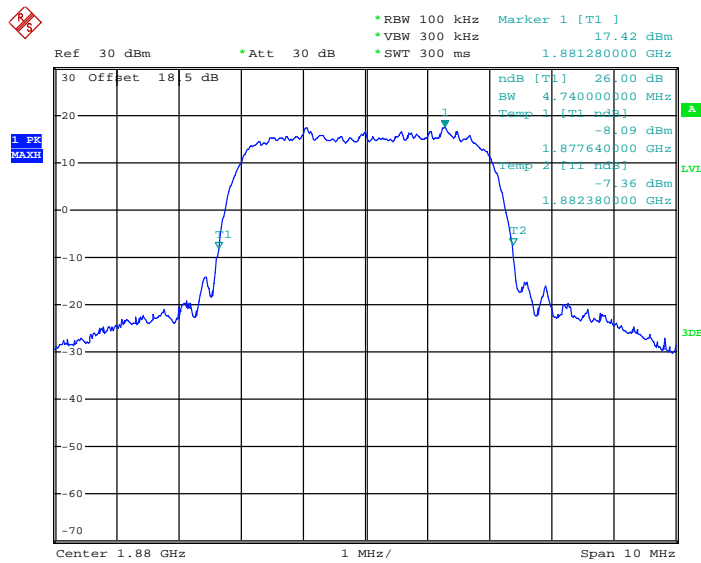

Date: 12.JAN.2014 14:44:55



99% Occupied Bandwidth Plot on Channel 9538 (1907.6 MHz)

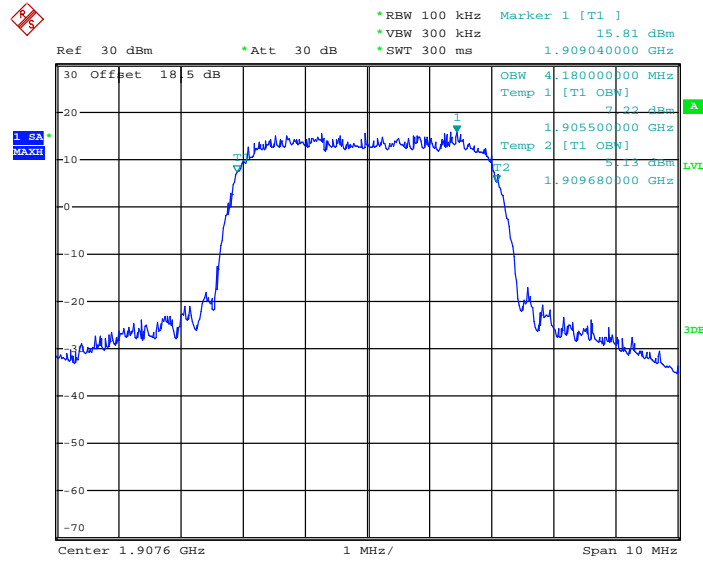

Date: 12.JAN.2014 14:47:44

26dB Bandwidth Plot on Channel 9538 (1907.6 MHz)

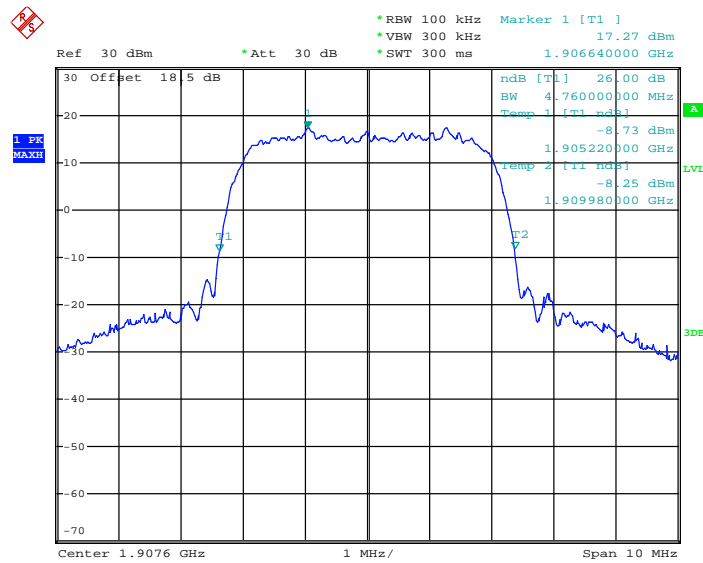

Date: 12.JAN.2014 14:45:57



SIM2 Card:

Band :	GSM 1900	Test Mode :	GSM Link (GMSK)
--------	----------	-------------	-----------------

99% Occupied Bandwidth Plot on Channel 512 (1850.2 MHz)

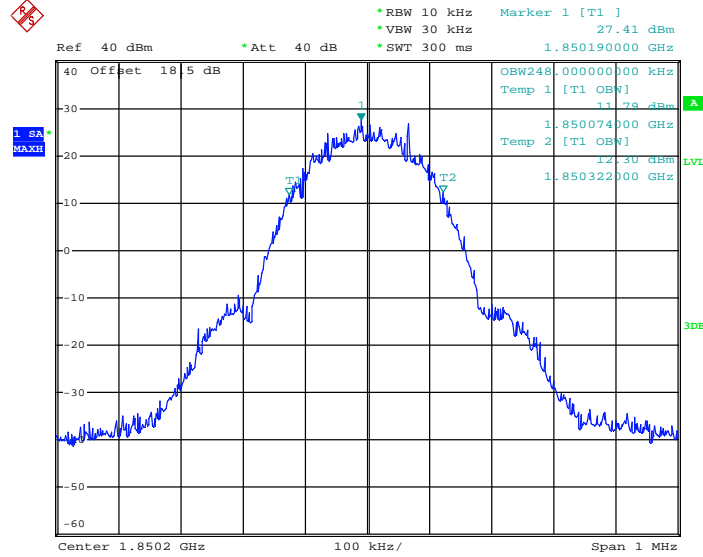

Date: 8.FEB.2014 11:29:50

26dB Bandwidth Plot on Channel 512 (1850.2 MHz)

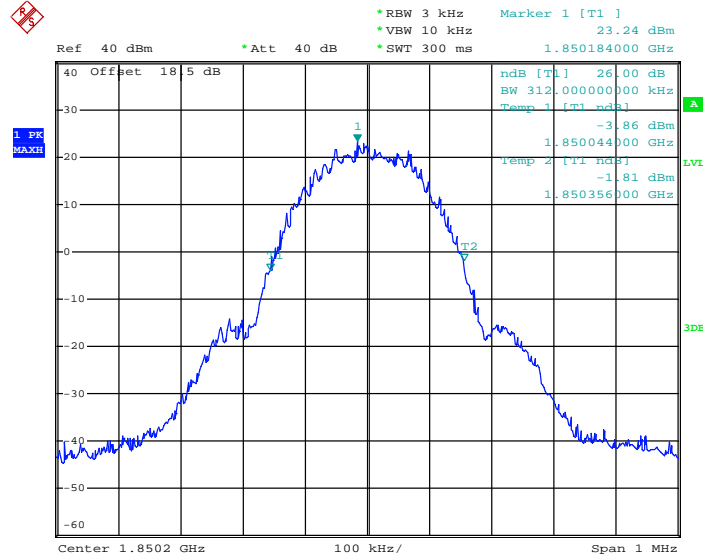

Date: 8.FEB.2014 11:37:13



99% Occupied Bandwidth Plot on Channel 661 (1880.0 MHz)

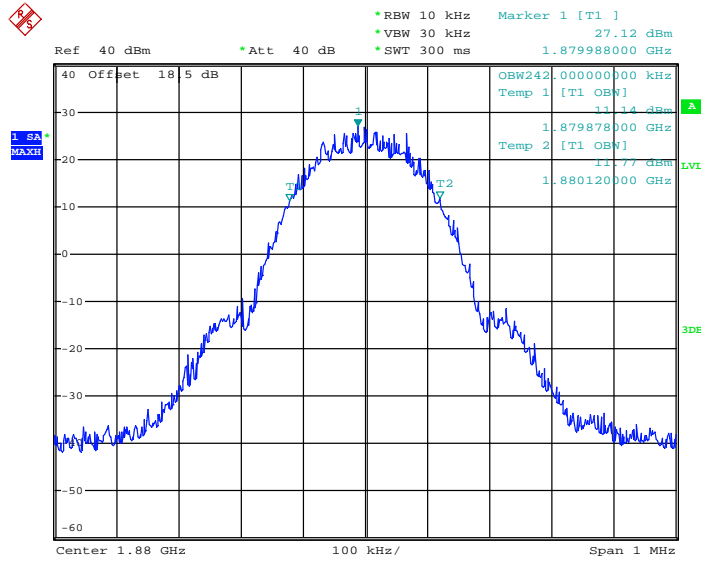

Date: 8.FEB.2014 11:31:04

26dB Bandwidth Plot on Channel 661 (1880.0 MHz)

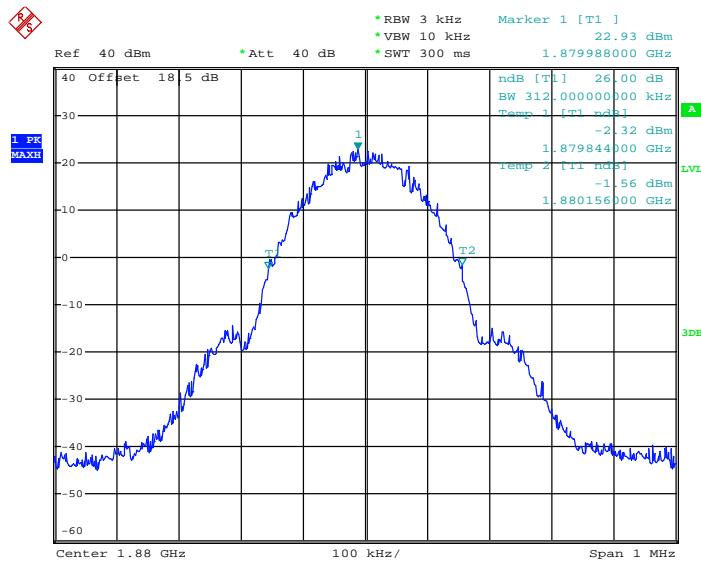

Date: 8.FEB.2014 11:35:15



99% Occupied Bandwidth Plot on Channel 810 (1909.8 MHz)

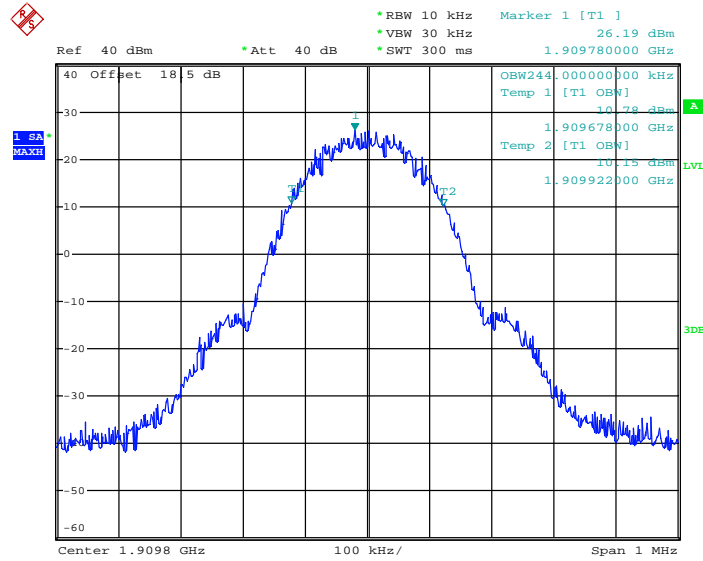

Date: 8.FEB.2014 11:32:32

26dB Bandwidth Plot on Channel 810 (1909.8 MHz)

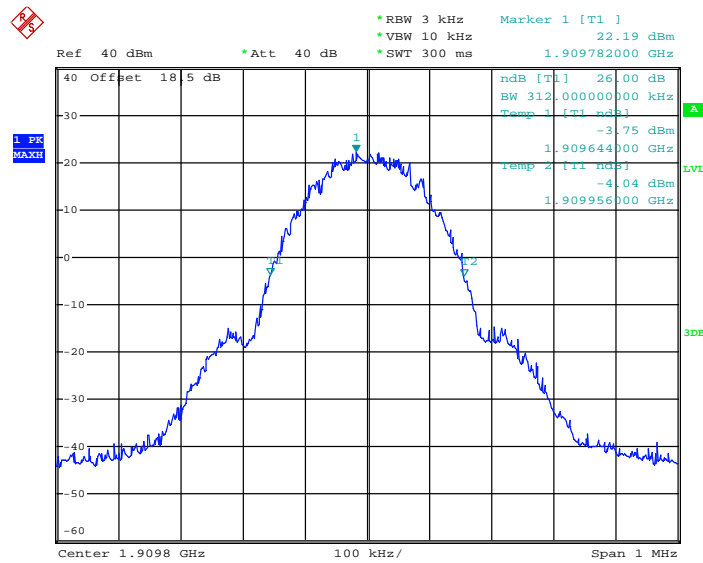

Date: 8.FEB.2014 11:34:07



<b>Band :</b>	GSM 1900	<b>Test Mode :</b>	EDGE class 8 Link (8PSK)
---------------	----------	--------------------	--------------------------

**99% Occupied Bandwidth Plot on Channel 512 (1850.2 MHz)**

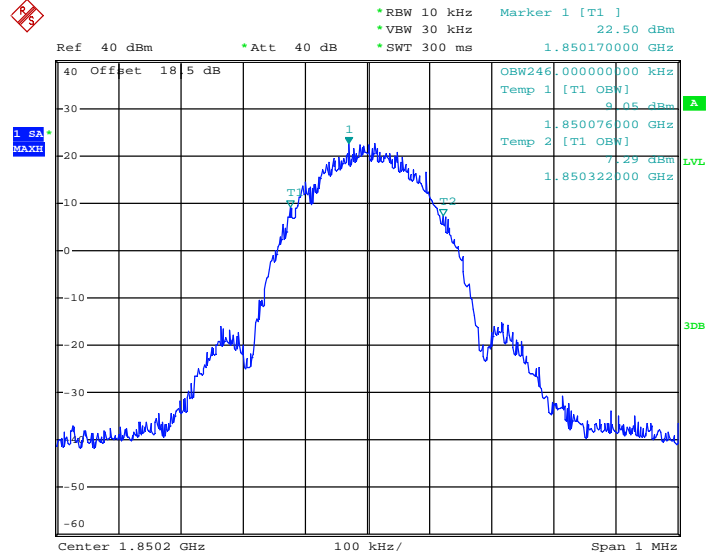

Date: 8.FEB.2014 10:03:43

**26dB Bandwidth Plot on Channel 512 (1850.2 MHz)**

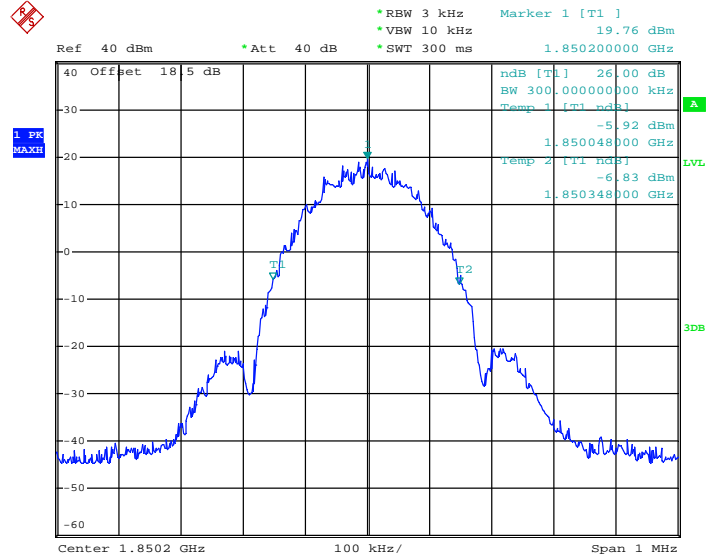

Date: 8.FEB.2014 09:55:40



99% Occupied Bandwidth Plot on Channel 661 (1880.0 MHz)

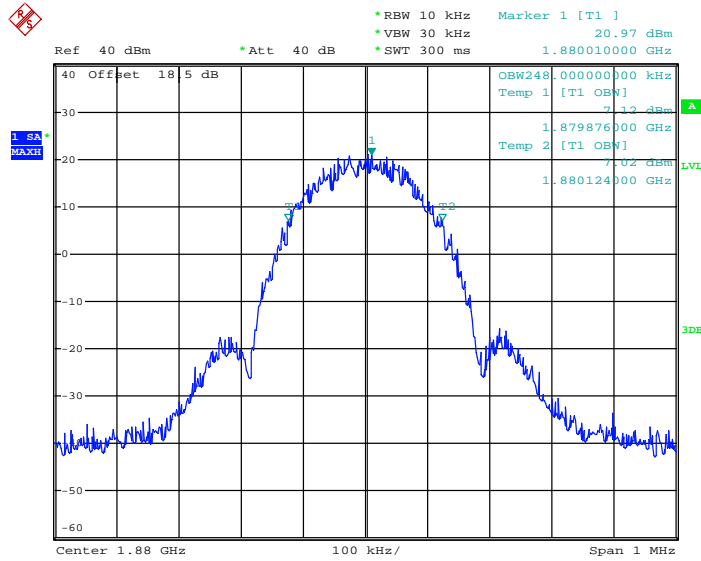

Date: 8.FEB.2014 10:01:49

26dB Bandwidth Plot on Channel 661 (1880.0 MHz)

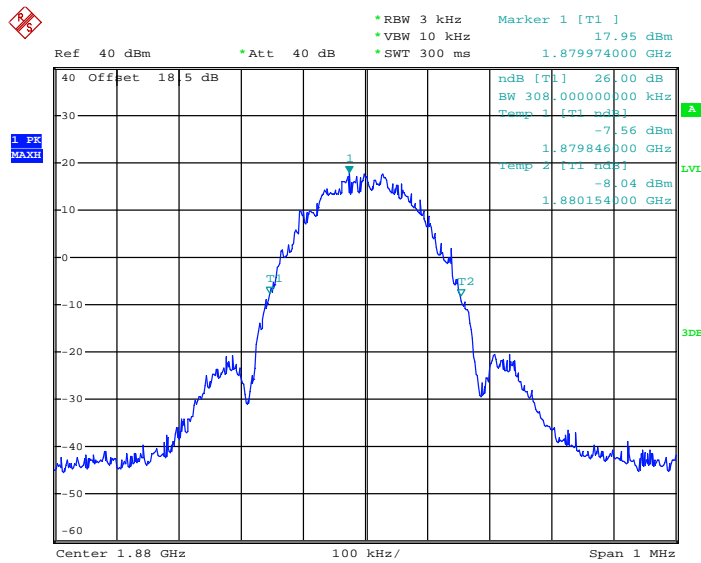

Date: 8.FEB.2014 09:56:57



99% Occupied Bandwidth Plot on Channel 810 (1909.8 MHz)

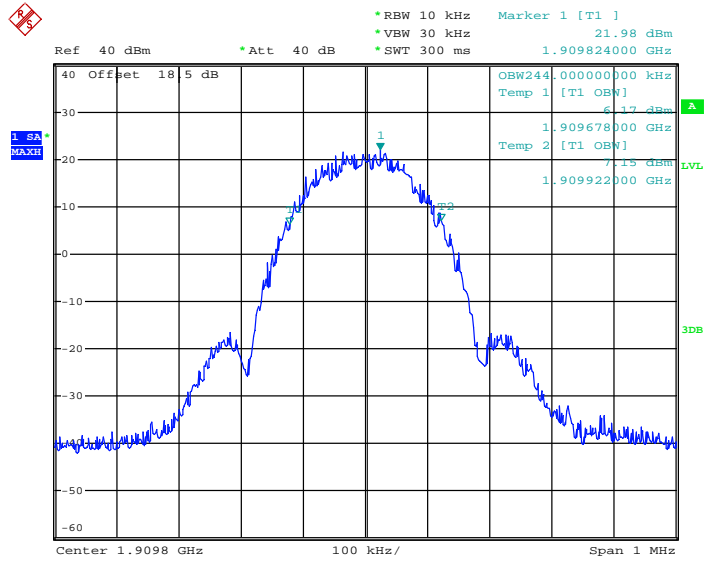

Date: 8.FEB.2014 10:00:33

26dB Bandwidth Plot on Channel 810 (1909.8 MHz)

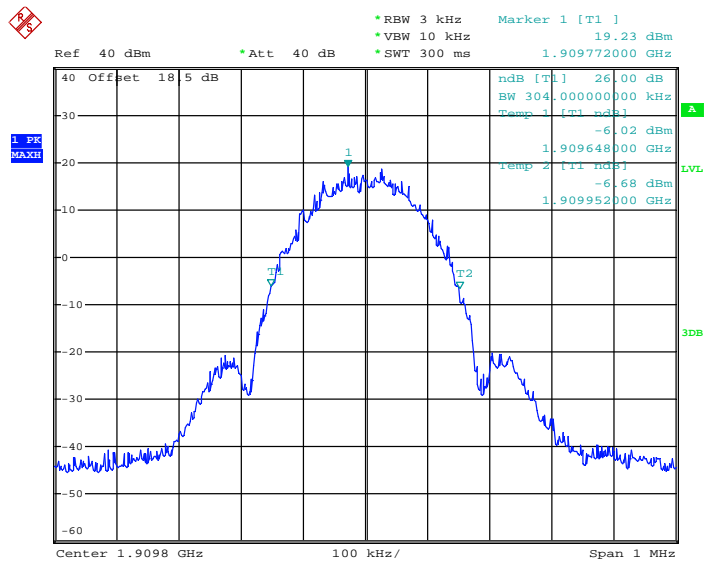

Date: 8.FEB.2014 09:58:22

### 3.5 Band Edge Measurement

#### 3.5.1 Description of Band Edge Measurement

The power of any emission outside of the authorized operating frequency ranges must be lower than the transmitter power (P) by a factor of at least  $43 + 10 \log (P)$  dB.

#### 3.5.2 Measuring Instruments

The measuring equipment is listed in the section 4 of this test report.

#### 3.5.3 Test Procedures

1. The EUT was connected to Spectrum Analyzer and Base Station via power divider.
2. The RF output of EUT was connected to the spectrum analyzer by RF cable and attenuator. The path loss was compensated to the results for each measurement.
3. The band edges of low and high channels for the highest RF powers were measured. Setting RBW as roughly  $BW/100$ .
4. The RF fundamental frequency should be excluded against the limit line in the operating frequency band.
5. The limit line is derived from  $43 + 10\log(P)$  dB below the transmitter power P(Watts)
 
$$= P(W) - [43 + 10\log(P)] \text{ (dB)}$$

$$= [30 + 10\log(P)] \text{ (dBm)} - [43 + 10\log(P)] \text{ (dB)}$$

$$= -13\text{dBm}.$$

#### 3.5.4 Test Setup

<Conducted Band Edge >

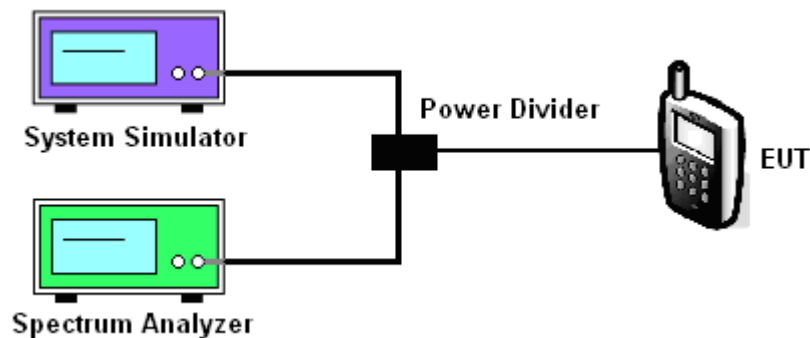

### 3.5.5 Test Result (Plots) of Conducted Band Edge

SIM1 Card:

Band :	GSM850	Test Mode :	GSM Link (GMSK)
Correction Factor :	0.20dB	Maximum 26dB Bandwidth :	0.314MHz
Band Edge :	-16.66dBm	Measurement Value :	-16.86dBm

Lower Band Edge Plot on Channel 128 (824.2 MHz)

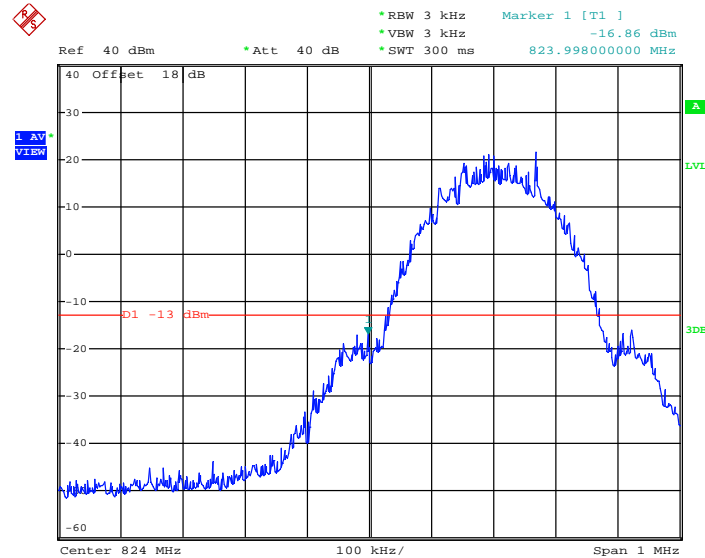

Date: 12.JAN.2014 09:49:52

1. Correction Factor(dB)= 10log(1% Emission BW/RBW)
  2. Band Edge= Measurement Value + Correction Factor(dB)
- For example, -16.86dBm + 0.20dB = -16.66dBm



Band :	GSM850	Test Mode :	GSM Link (GMSK)
Correction Factor :	0.20dB	Maximum 26dB Bandwidth :	0.314MHz
Band Edge :	-15.71dBm	Measurement Value :	-15.91dBm

Higher Band Edge Plot on Channel 251 (848.8 MHz)

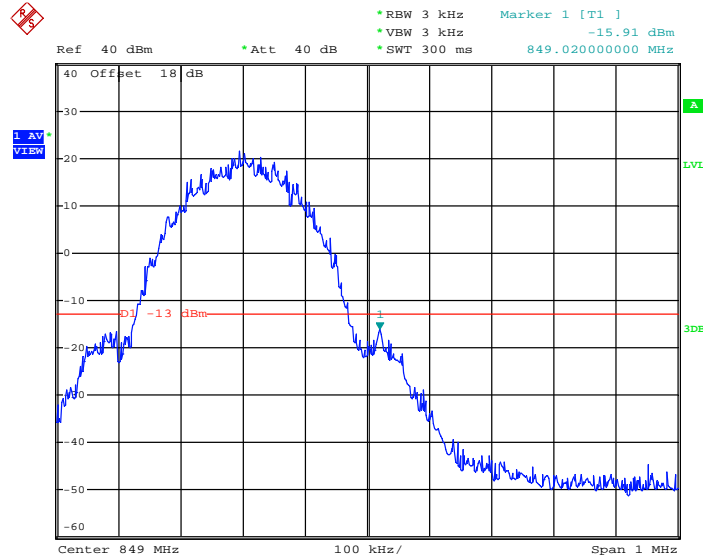

Date: 12.JAN.2014 09:51:12

1. Correction Factor(dB)= 10log(1% Emission BW/RBW)
2. Band Edge= Measurement Value + Correction Factor(dB)



Band :	GSM850	Test Mode :	EDGE class 8 Link (8PSK)
Correction Factor :	0.11dB	Maximum 26dB Bandwidth :	0.308MHz
Band Edge :	-25.04dBm	Measurement Value :	-25.15dBm

Lower Band Edge Plot on Channel 128 (824.2 MHz)

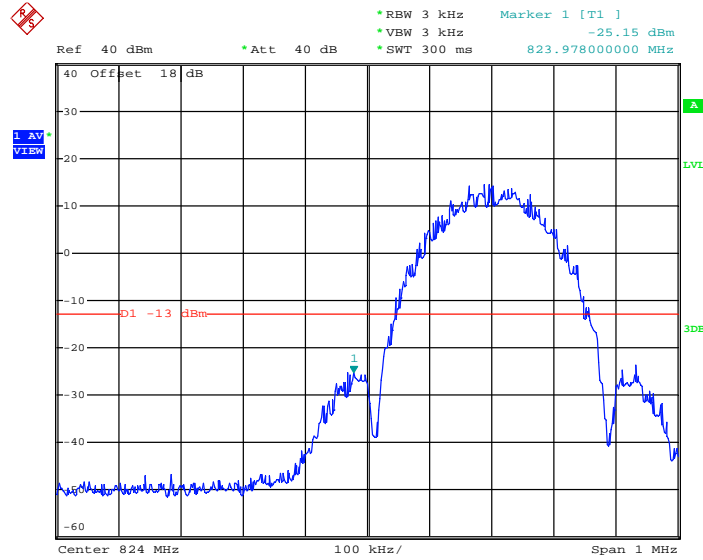

Date: 12.JAN.2014 13:21:25

1. Correction Factor(dB)= 10log(1% Emission BW/RBW)
2. Band Edge= Measurement Value + Correction Factor(dB)



Band :	GSM850	Test Mode :	EDGE class 8 Link (8PSK)
Correction Factor :	0.11dB	Maximum 26dB Bandwidth :	0.308MHz
Band Edge :	-25.07dBm	Measurement Value :	-25.18dBm

Higher Band Edge Plot on Channel 251 (848.8 MHz)

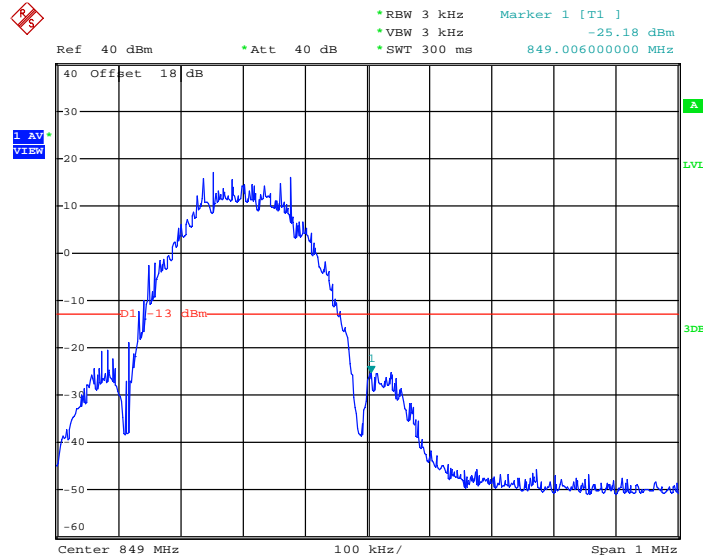

Date: 12.JAN.2014 13:23:56

1. Correction Factor(dB)=  $10\log(1\% \text{ Emission BW/RBW})$
2. Band Edge= Measurement Value + Correction Factor(dB)



Band :	GSM1900	Test Mode :	GSM Link (GMSK)
Correction Factor :	0.17dB	Maximum 26dB Bandwidth :	0.312MHz
Band Edge :	-21.05dBm	Measurement Value :	-21.22dBm

Lower Band Edge Plot on Channel 512 (1850.2 MHz)

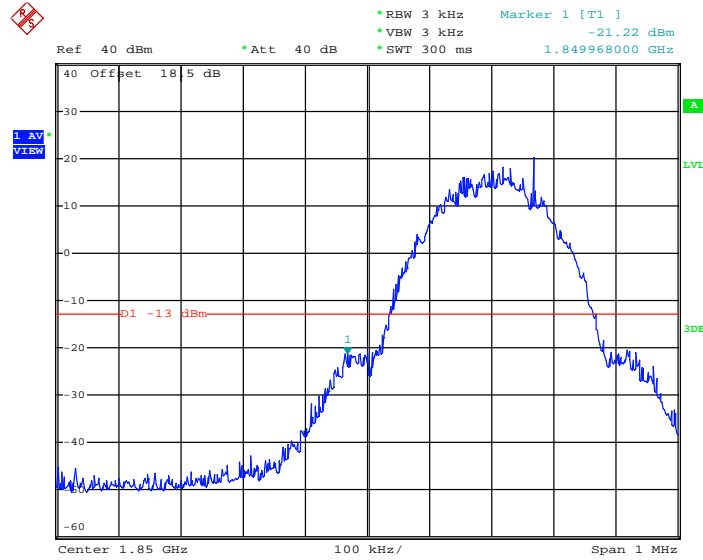

Date: 12.JAN.2014 11:26:14

1. Correction Factor(dB)= 10log(1% Emission BW/RBW)
2. Band Edge= Measurement Value + Correction Factor(dB)



Band :	GSM1900	Test Mode :	GSM Link (GMSK)
Correction Factor :	0.17dB	Maximum 26dB Bandwidth :	0.312MHz
Band Edge :	-19.87dBm	Measurement Value :	-20.04dBm

Higher Band Edge Plot on Channel 810 (1909.8 MHz)

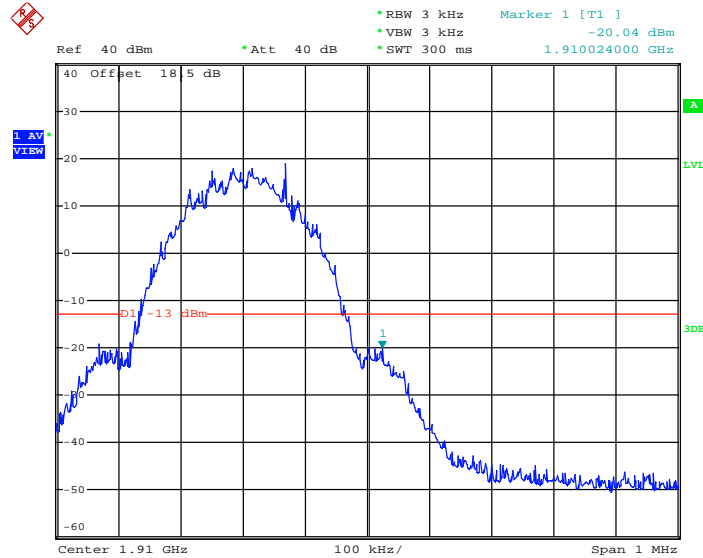

Date: 12.JAN.2014 11:24:04

1. Correction Factor(dB)= 10log(1% Emission BW/RBW)
2. Band Edge= Measurement Value + Correction Factor(dB)



Band :	GSM1900	Test Mode :	EDGE class 8 Link (8PSK)
Correction Factor :	0.11dB	Maximum 26dB Bandwidth :	0.308MHz
Band Edge :	-26.28dBm	Measurement Value :	-26.39dBm

Lower Band Edge Plot on Channel 512 (1850.2 MHz)

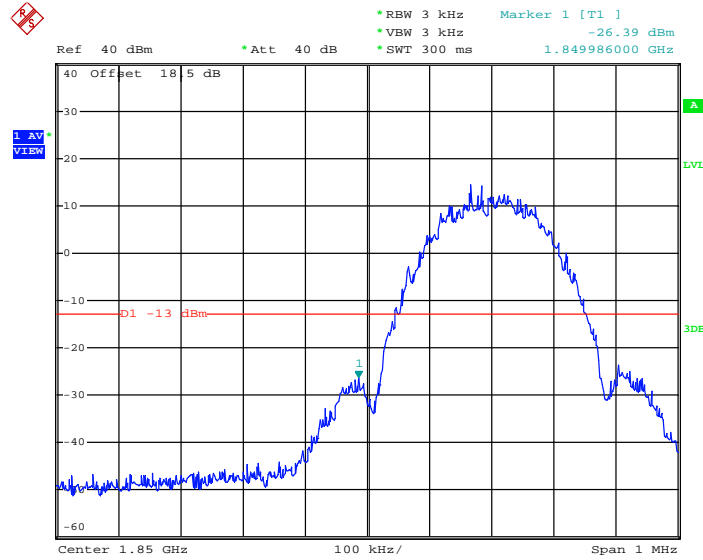

Date: 12.JAN.2014 12:17:38

1. Correction Factor(dB)= 10log(1% Emission BW/RBW)
2. Band Edge= Measurement Value + Correction Factor(dB)



<b>Band :</b>	GSM1900	<b>Test Mode :</b>	EDGE class 8 Link (8PSK)
<b>Correction Factor :</b>	0.11dB	<b>Maximum 26dB Bandwidth :</b>	0.308MHz
<b>Band Edge :</b>	-21.75dBm	<b>Measurement Value :</b>	-21.86dBm

Higher Band Edge Plot on Channel 810 (1909.8 MHz)

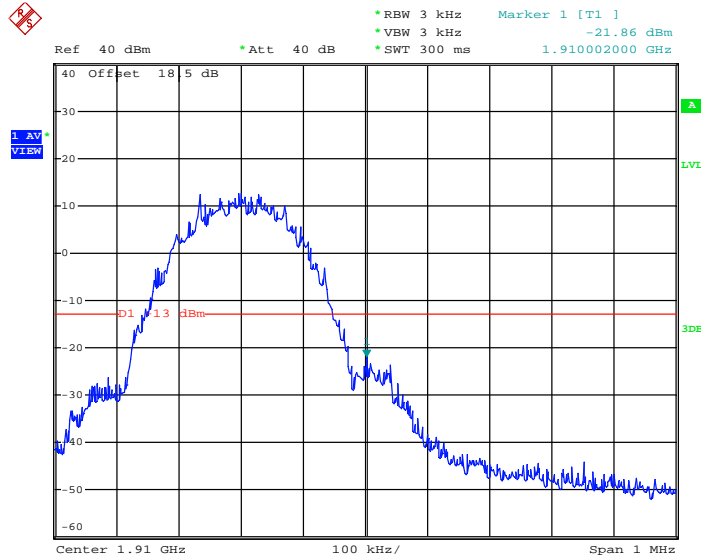

Date: 12.JAN.2014 12:19:12

1. Correction Factor(dB)= 10log(1% Emission BW/RBW)
2. Band Edge= Measurement Value + Correction Factor(dB)



Band :	WCDMA Band V	Test Mode :	RMC 12.2Kbps Link (QPSK)
Correction Factor :	-3.21dB	Maximum 26dB Bandwidth :	4.78MHz
Band Edge :	-22.70dBm	Measurement Value :	-19.49dBm

Lower Band Edge Plot on Channel 4132 (826.4 MHz)

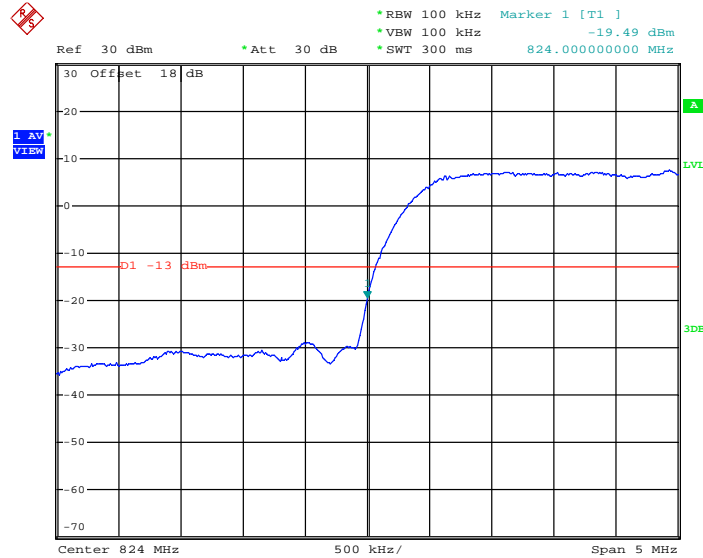

Date: 12.JAN.2014 13:56:22

1. Correction Factor(dB)=  $10\log(1\% \text{ Emission BW/RBW})$
2. Band Edge= Measurement Value + Correction Factor(dB)



Band :	WCDMA Band V	Test Mode :	RMC 12.2Kbps Link (QPSK)
Correction Factor :	-3.21dB	Maximum 26dB Bandwidth :	4.78MHz
Band Edge :	-23.14dBm	Measurement Value :	-19.93dBm

Higher Band Edge Plot on Channel 4233 (846.6 MHz)

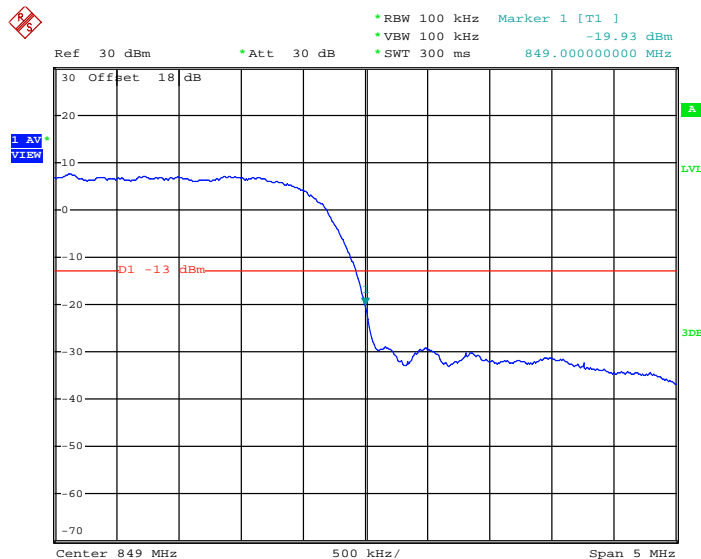

Date: 12.JAN.2014 13:57:26

1. Correction Factor(dB)= 10log(1% Emission BW/RBW)
2. Band Edge= Measurement Value + Correction Factor(dB)



Band :	WCDMA Band II	Test Mode :	RMC 12.2Kbps Link (QPSK)
Correction Factor :	-3.21dB	Maximum 26dB Bandwidth :	4.78MHz
Band Edge :	-24.73dBm	Measurement Value :	-21.52dBm

Lower Band Edge Plot on Channel 9262 (1852.4 MHz)

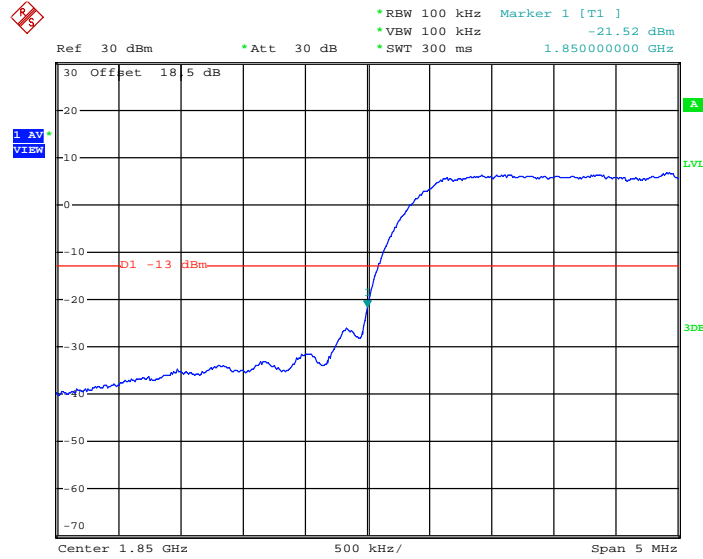

Date: 12.JAN.2014 14:52:15

1. Correction Factor(dB)=  $10\log(1\% \text{ Emission BW/RBW})$
2. Band Edge= Measurement Value + Correction Factor(dB)



Band :	WCDMA Band II	Test Mode :	RMC 12.2Kbps Link (QPSK)
Correction Factor :	-3.21dB	Maximum 26dB Bandwidth :	4.78MHz
Band Edge :	-24.48dBm	Measurement Value :	-21.27dBm

Higher Band Edge Plot on Channel 9538 (1907.6 MHz)

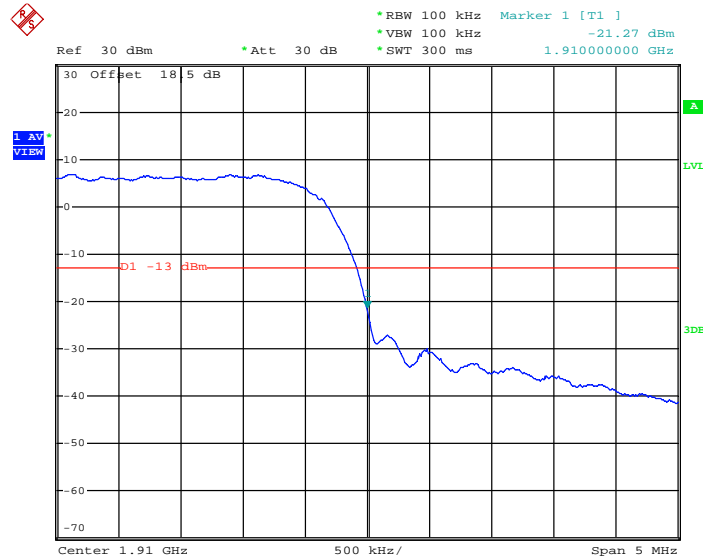

Date: 12.JAN.2014 14:53:46

1. Correction Factor(dB)=  $10\log(1\% \text{ Emission BW/RBW})$
2. Band Edge= Measurement Value + Correction Factor(dB)



SIM2 Card:

Band :	GSM1900	Test Mode :	GSM Link (GMSK)
Correction Factor :	0.17dB	Maximum 26dB Bandwidth :	0.312MHz
Band Edge :	-19.38dBm	Measurement Value :	-19.55dBm

Lower Band Edge Plot on Channel 512 (1850.2 MHz)

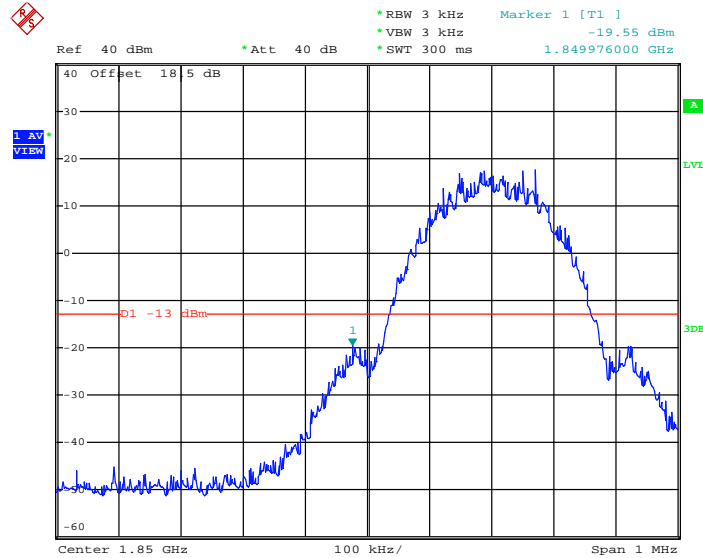

Date: 8.FEB.2014 11:05:42

1. Correction Factor(dB)= 10log(1% Emission BW/RBW)
2. Band Edge= Measurement Value + Correction Factor(dB)



Band :	GSM1900	Test Mode :	GSM Link (GMSK)
Correction Factor :	0.17dB	Maximum 26dB Bandwidth :	0.312MHz
Band Edge :	-20.35dBm	Measurement Value :	-20.52dBm

Higher Band Edge Plot on Channel 810 (1909.8 MHz)

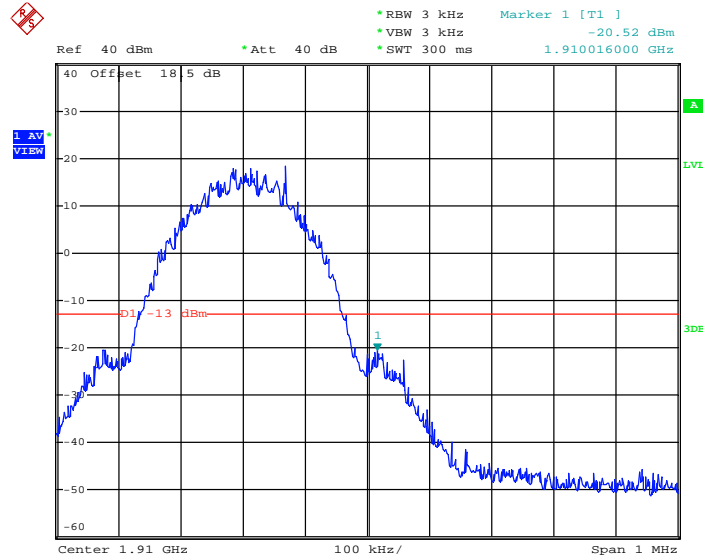

Date: 8.FEB.2014 11:04:31

1. Correction Factor(dB)= 10log(1% Emission BW/RBW)
2. Band Edge= Measurement Value + Correction Factor(dB)



Band :	GSM1900	Test Mode :	EDGE class 8 Link (8PSK)
Correction Factor :	0.11dB	Maximum 26dB Bandwidth :	0.308MHz
Band Edge :	-25.79dBm	Measurement Value :	-25.90dBm

Lower Band Edge Plot on Channel 512 (1850.2 MHz)

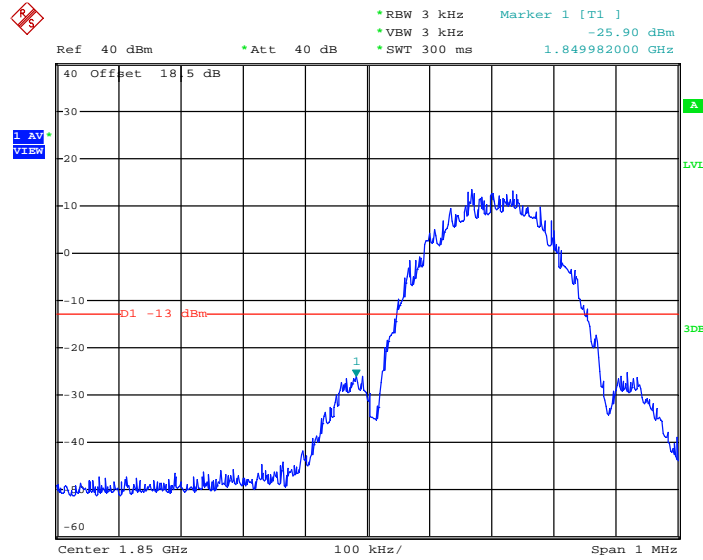

Date: 8.FEB.2014 10:15:24

- 1. Correction Factor(dB)= 10log(1% Emission BW/RBW)
- 2. Band Edge= Measurement Value + Correction Factor(dB)



Band :	GSM1900	Test Mode :	EDGE class 8 Link (8PSK)
Correction Factor :	0.11dB	Maximum 26dB Bandwidth :	0.308MHz
Band Edge :	-26.82dBm	Measurement Value :	-26.93dBm

Higher Band Edge Plot on Channel 810 (1909.8 MHz)

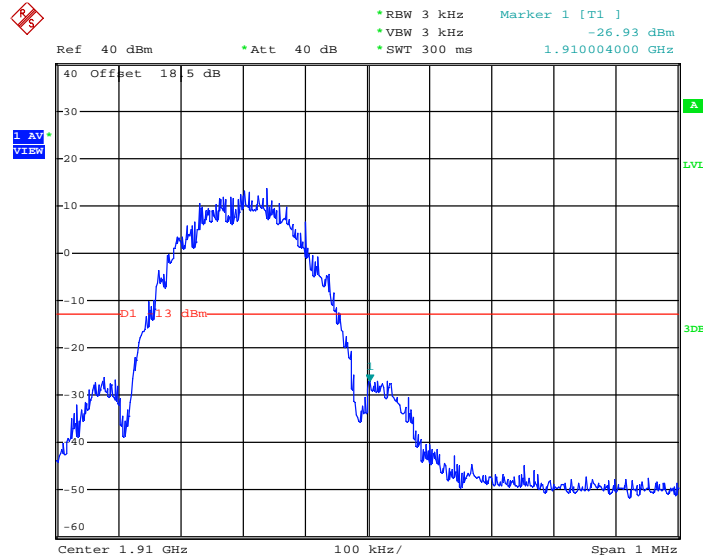

Date: 8.FEB.2014 10:17:00

1. Correction Factor(dB)=  $10\log(1\% \text{ Emission BW/RBW})$
2. Band Edge= Measurement Value + Correction Factor(dB)

### 3.6 Conducted Spurious Emission Measurement

#### 3.6.1 Description of Conducted Spurious Emission Measurement

The power of any emission outside of the authorized operating frequency ranges must be lower than the transmitter power (P) by a factor of at least  $43 + 10 \log (P)$  dB.

It is measured by means of a calibrated spectrum analyzer and scanned from 30 MHz up to a frequency including its 10<sup>th</sup> harmonic.

#### 3.6.2 Measuring Instruments

The measuring equipment is listed in the section 4 of this test report.

#### 3.6.3 Test Procedures

1. The EUT was connected to spectrum analyzer and base station via power divider.
2. The RF output of EUT was connected to the spectrum analyzer by RF cable and attenuator. The path loss was compensated to the results for each measurement.
3. The middle channel for the highest RF power within the transmitting frequency was measured.
4. The conducted spurious emission for the whole frequency range was taken.
5. The RF fundamental frequency should be excluded against the limit line in the operating frequency band.
6. The limit line is derived from  $43 + 10\log(P)$  dB below the transmitter power P(Watts)
 
$$= P(W) - [43 + 10\log(P)] \text{ (dB)}$$

$$= [30 + 10\log(P)] \text{ (dBm)} - [43 + 10\log(P)] \text{ (dB)}$$

$$= -13\text{dBm}$$

#### 3.6.4 Test Setup

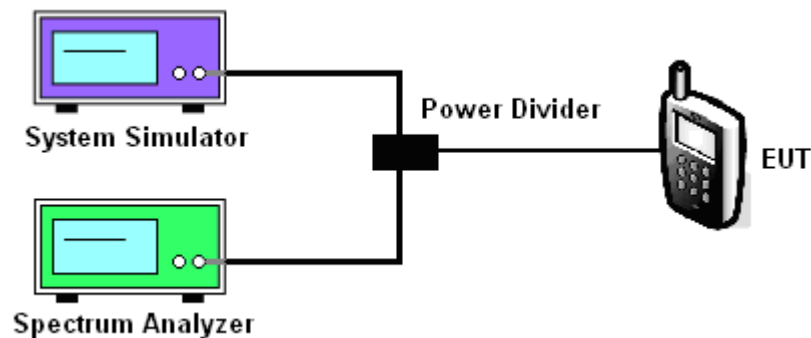

### 3.6.5 Test Result (Plots) of Conducted Spurious Emission

SIM1 Card:

Band :	GSM850	Channel :	CH128
Test Mode :	GSM Link (GMSK)	Frequency :	824.2MHz

#### Conducted Spurious Emission Plot between 30MHz ~ 1GHz

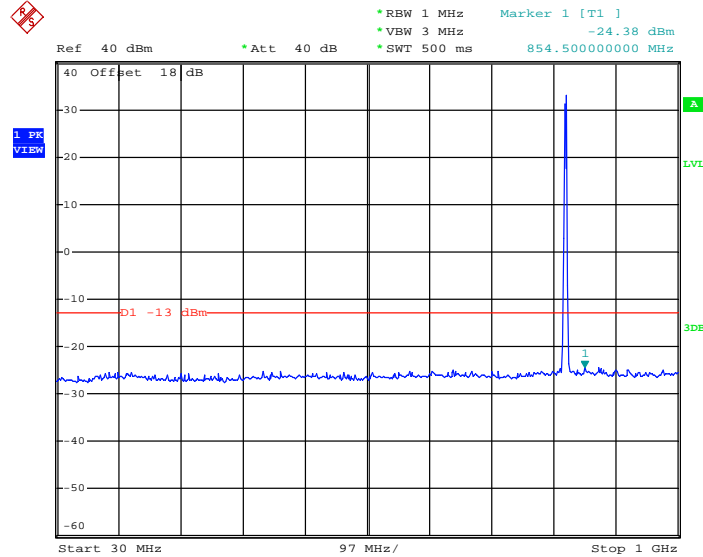

Date: 12.JAN.2014 09:54:59

#### Conducted Spurious Emission Plot between 1GHz ~ 3GHz

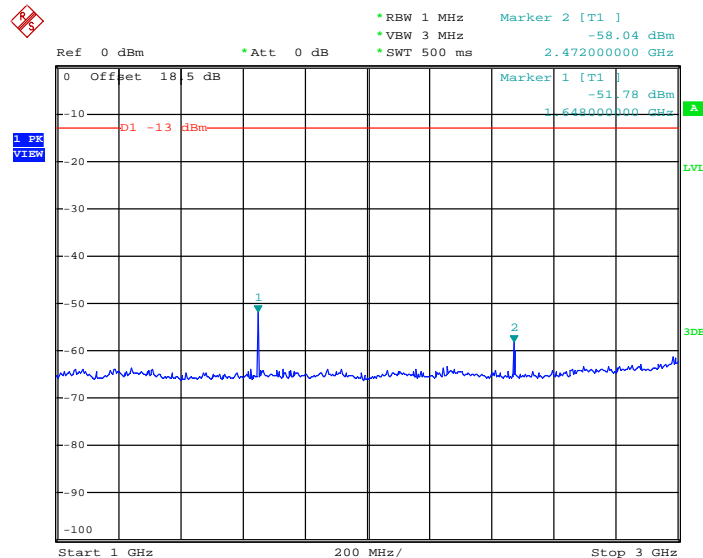

Date: 12.JAN.2014 10:05:15



### Conducted Spurious Emission Plot between 3GHz ~ 7GHz

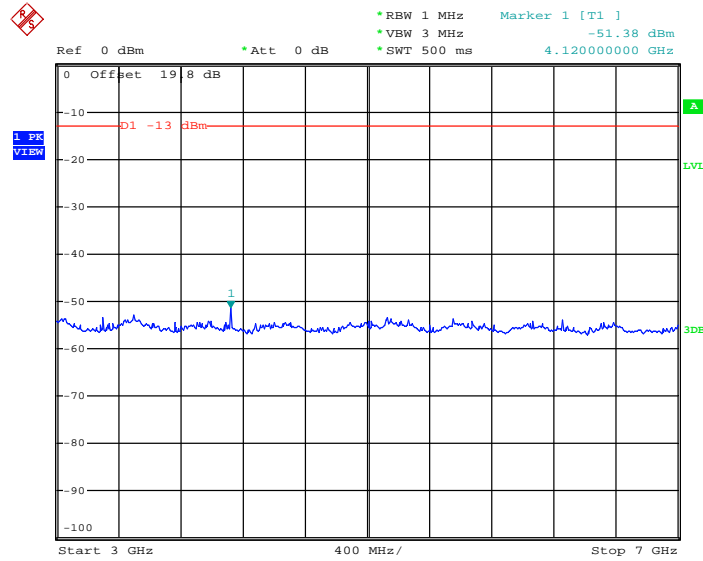

Date: 12.JAN.2014 10:06:59

### Conducted Spurious Emission Plot between 7GHz ~ 9GHz

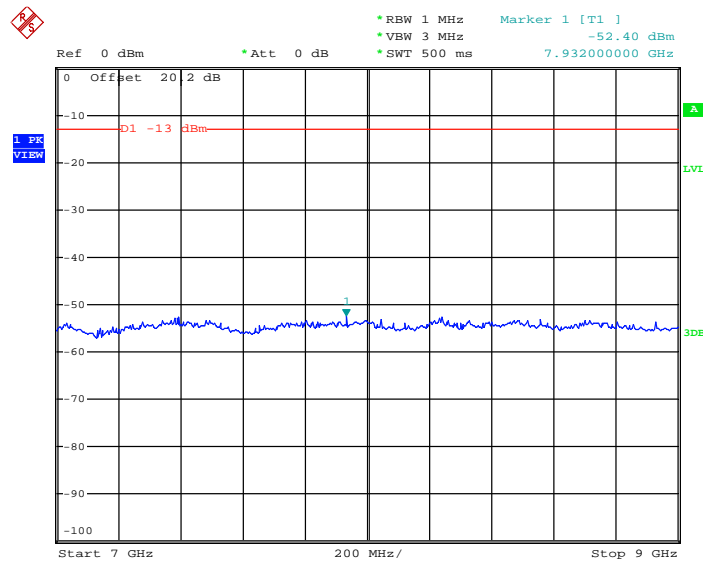

Date: 12.JAN.2014 10:13:56



Band :	GSM850	Channel :	CH189
Test Mode :	GSM Link (GMSK)	Frequency :	836.4 MHz

Conducted Spurious Emission Plot between 30MHz ~ 1GHz

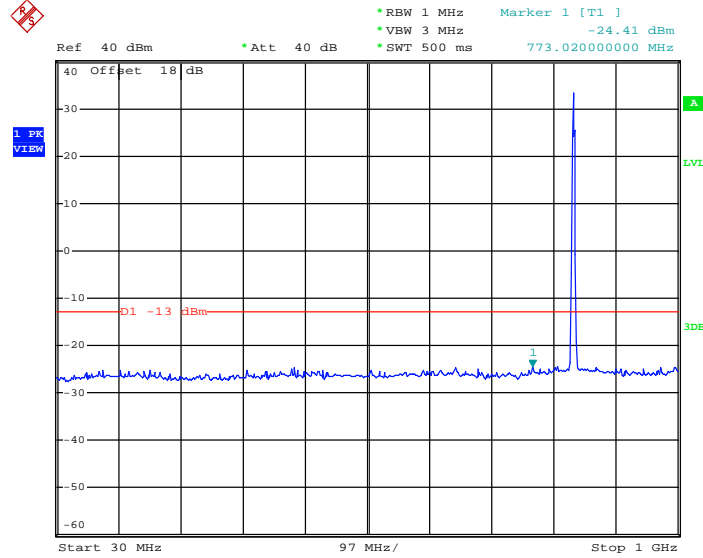

Date: 12.JAN.2014 09:56:50

Conducted Spurious Emission Plot between 1GHz ~ 3GHz

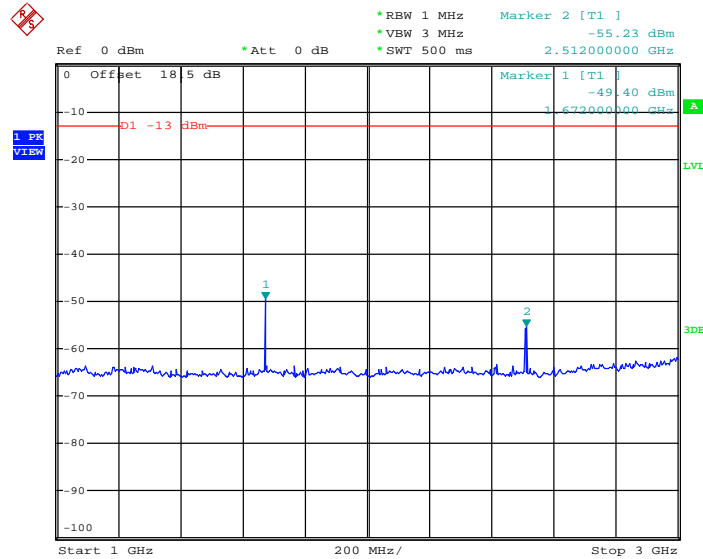

Date: 12.JAN.2014 10:02:46



### Conducted Spurious Emission Plot between 3GHz ~ 7GHz

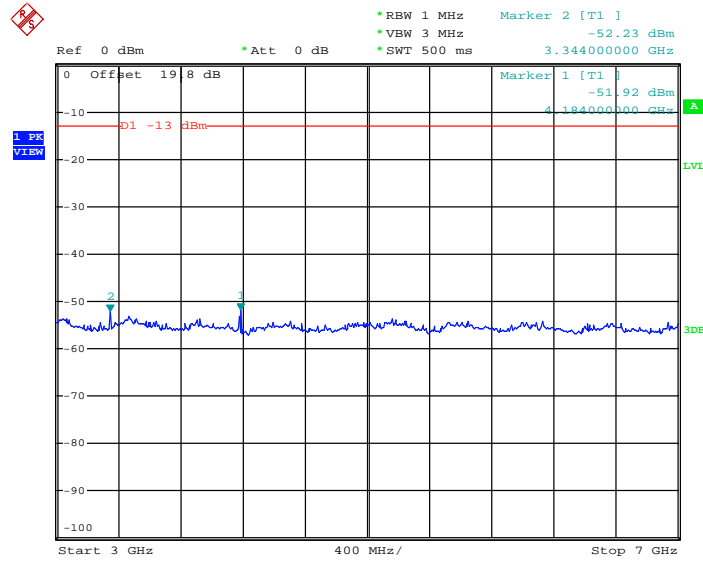

Date: 12.JAN.2014 10:08:58

### Conducted Spurious Emission Plot between 7GHz ~ 9GHz

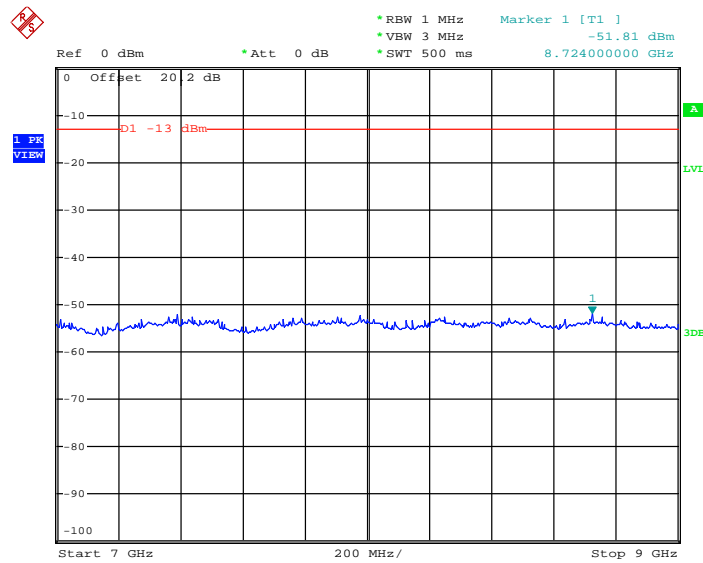

Date: 12.JAN.2014 10:13:03



Band :	GSM850	Channel :	CH251
Test Mode :	GSM Link (GMSK)	Frequency :	848.8 MHz

Conducted Spurious Emission Plot between 30MHz ~ 1GHz

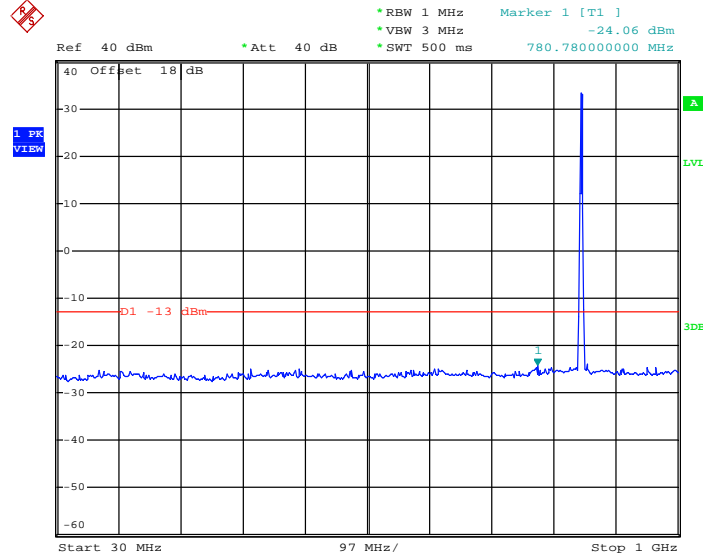

Date: 12.JAN.2014 09:58:11

Conducted Spurious Emission Plot between 1GHz ~ 3GHz

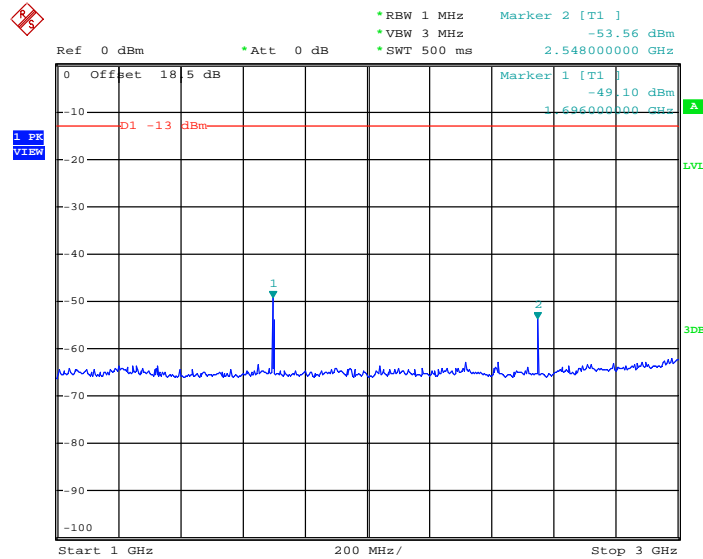

Date: 12.JAN.2014 10:01:28



### Conducted Spurious Emission Plot between 3GHz ~ 7GHz

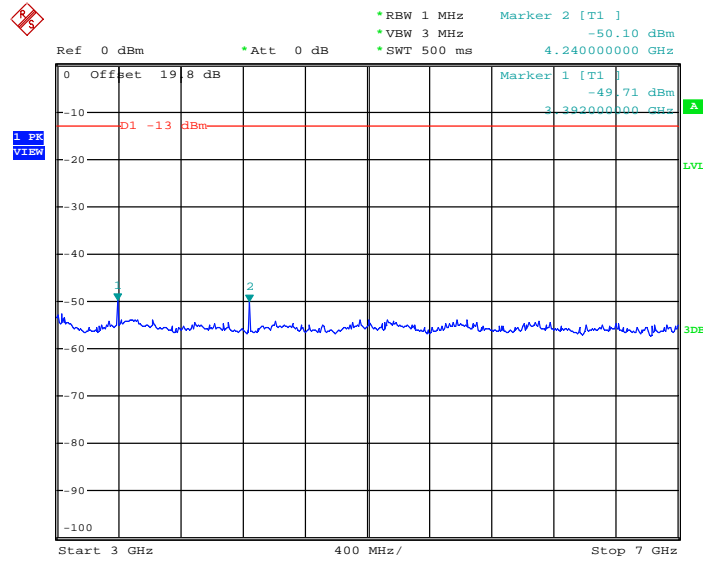

Date: 12.JAN.2014 10:10:21

### Conducted Spurious Emission Plot between 7GHz ~ 9GHz

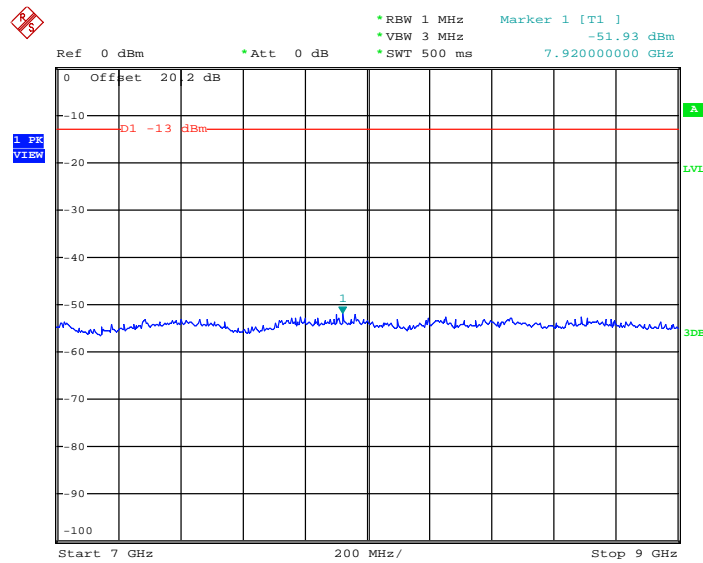

Date: 12.JAN.2014 10:11:50



Band :	GSM850	Channel :	CH128
Test Mode :	EDGE class 8 Link (8PSK)	Frequency :	824.2 MHz

Conducted Spurious Emission Plot between 30MHz ~ 1GHz

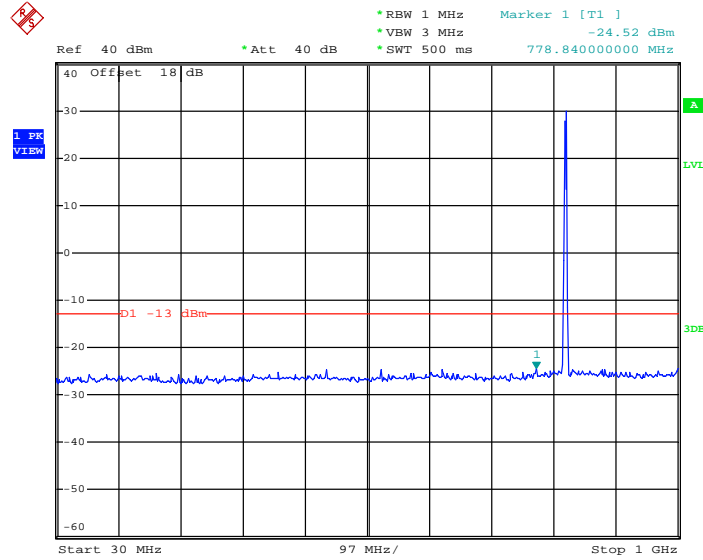

Date: 12.JAN.2014 13:04:02

Conducted Spurious Emission Plot between 1GHz ~ 3GHz

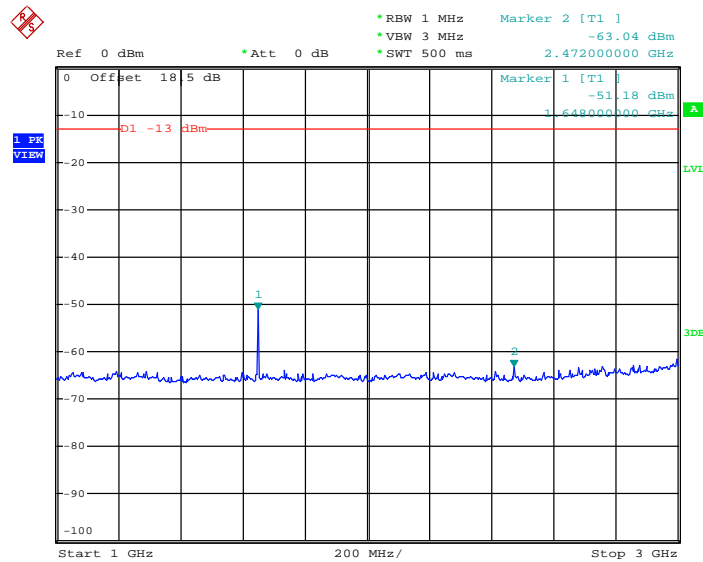

Date: 12.JAN.2014 12:48:29



### Conducted Spurious Emission Plot between 3GHz ~ 7GHz

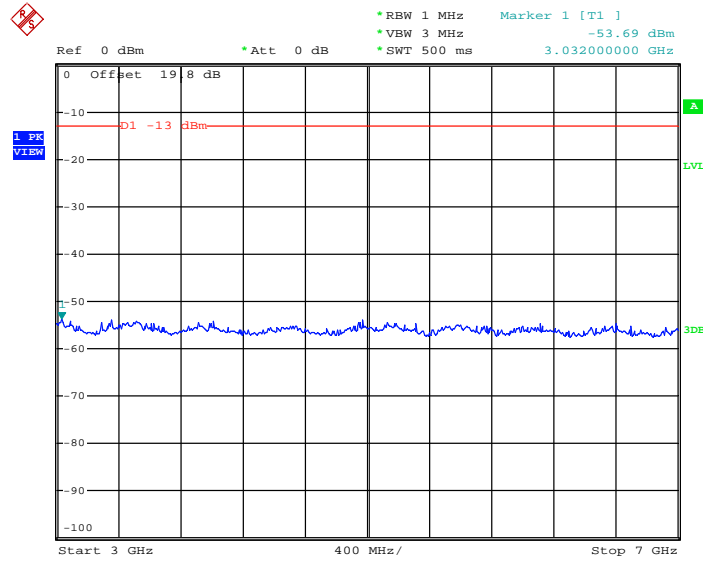

Date: 12.JAN.2014 12:53:38

### Conducted Spurious Emission Plot between 7GHz ~ 9GHz

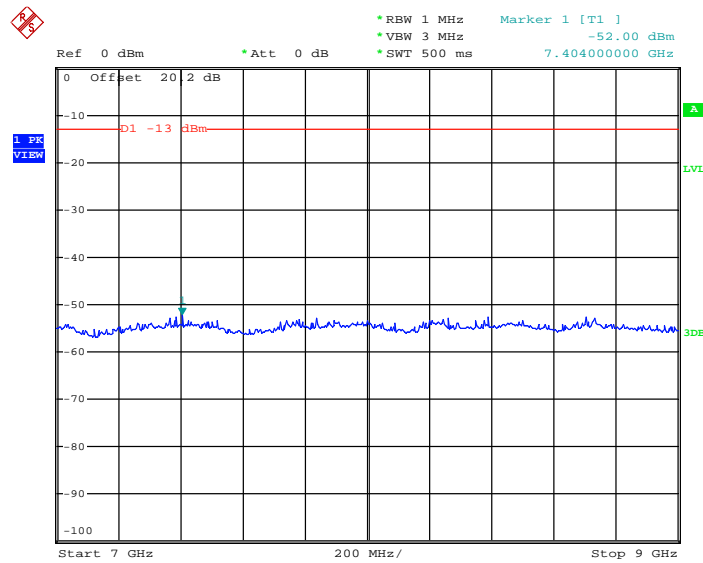

Date: 12.JAN.2014 12:54:49



Band :	GSM850	Channel :	CH189
Test Mode :	EDGE class 8 Link (8PSK)	Frequency :	836.4 MHz

Conducted Spurious Emission Plot between 30MHz ~ 1GHz

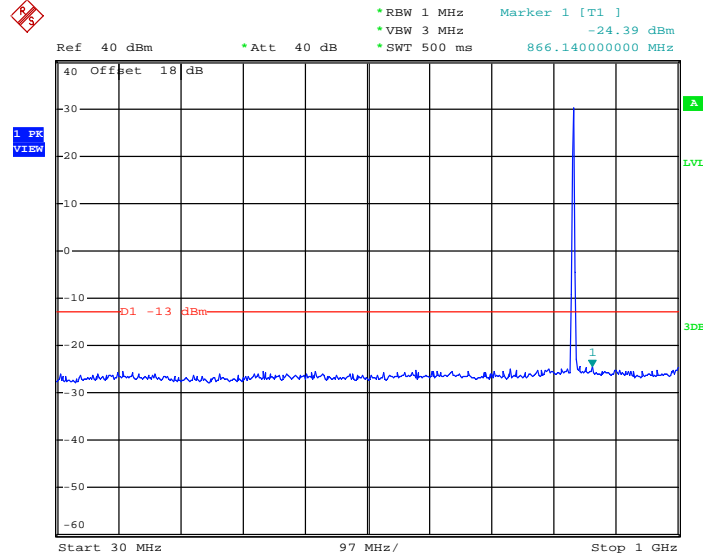

Date: 12.JAN.2014 13:02:24

Conducted Spurious Emission Plot between 1GHz ~ 3GHz

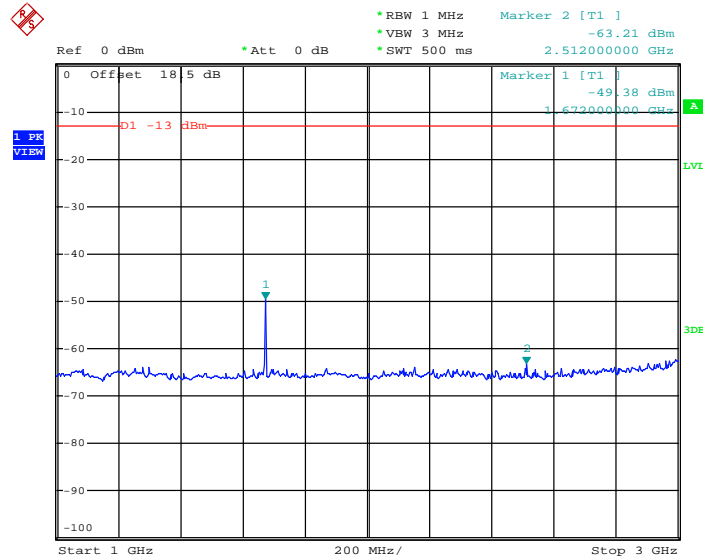

Date: 12.JAN.2014 12:50:01



### Conducted Spurious Emission Plot between 3GHz ~ 7GHz

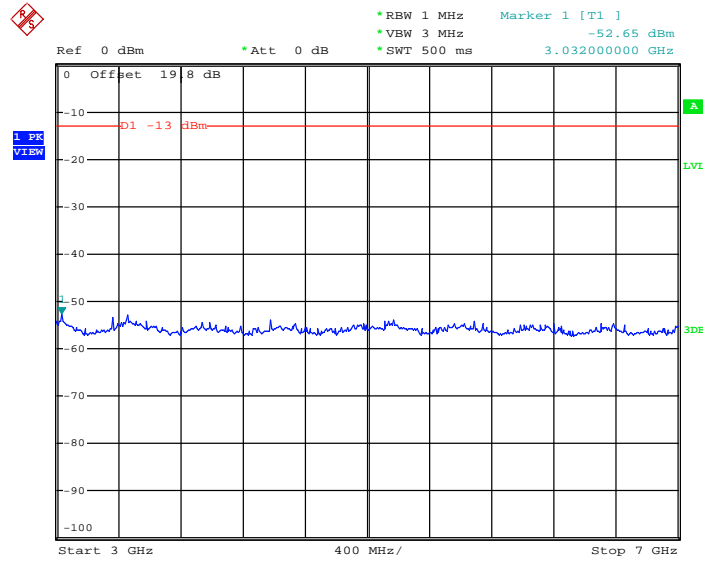

Date: 12.JAN.2014 12:53:04

### Conducted Spurious Emission Plot between 7GHz ~ 9GHz

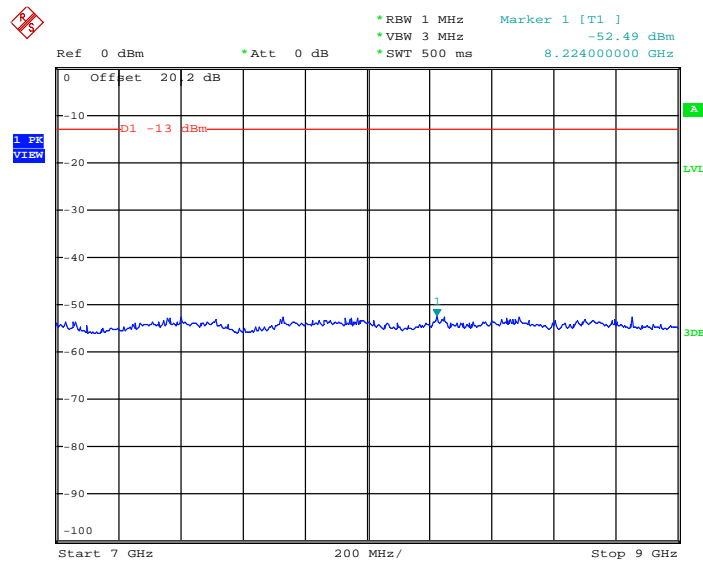

Date: 12.JAN.2014 12:56:17



Band :	GSM850	Channel :	CH251
Test Mode :	EDGE class 8 Link (8PSK)	Frequency :	848.8 MHz

Conducted Spurious Emission Plot between 30MHz ~ 1GHz

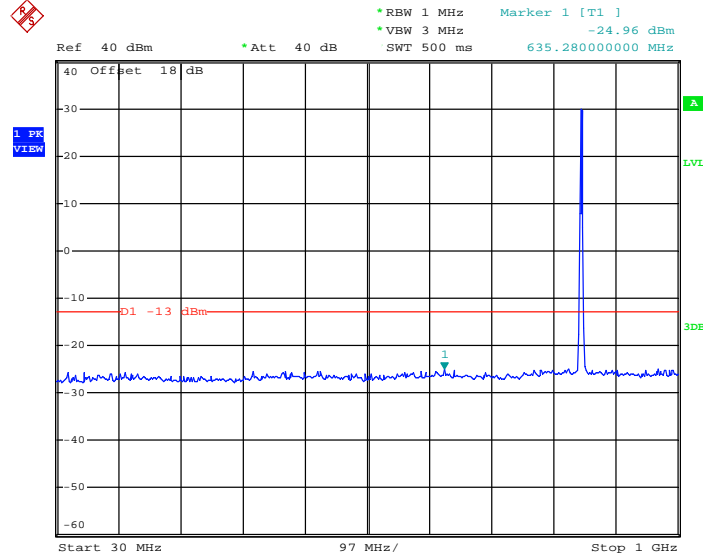

Date: 12.JAN.2014 13:01:13

Conducted Spurious Emission Plot between 1GHz ~ 3GHz

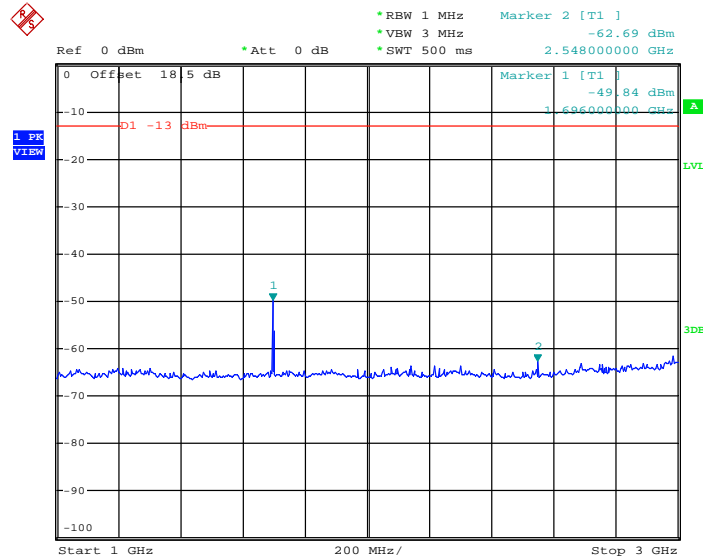

Date: 12.JAN.2014 12:51:02



### Conducted Spurious Emission Plot between 3GHz ~ 7GHz

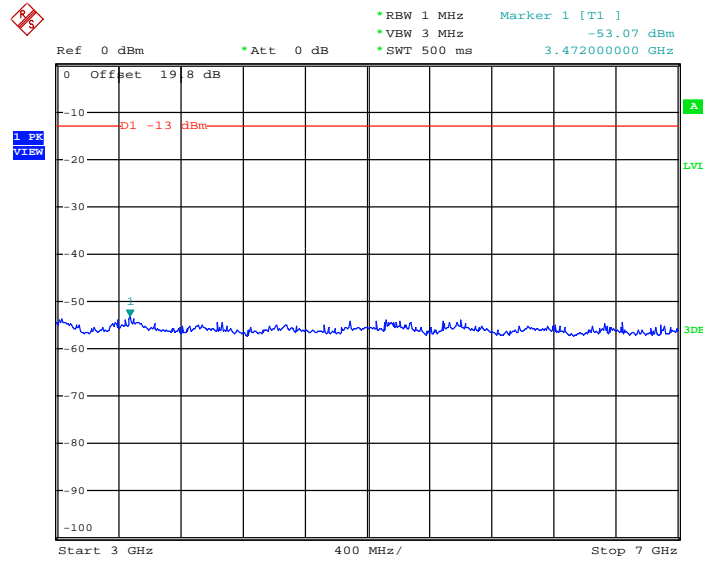

Date: 12.JAN.2014 12:52:24

### Conducted Spurious Emission Plot between 7GHz ~ 9GHz

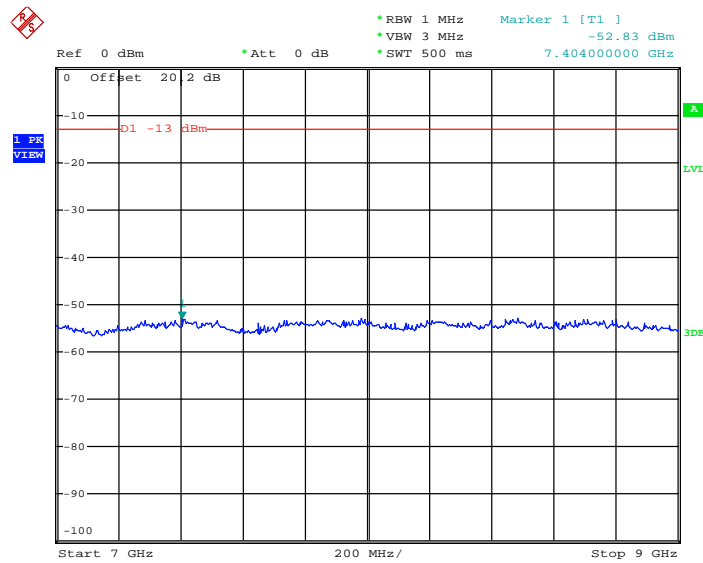

Date: 12.JAN.2014 12:57:24



Band :	GSM1900	Channel :	CH512
Test Mode :	GSM Link (GMSK)	Frequency :	1850.2 MHz

Conducted Spurious Emission Plot between 30MHz ~ 1GHz

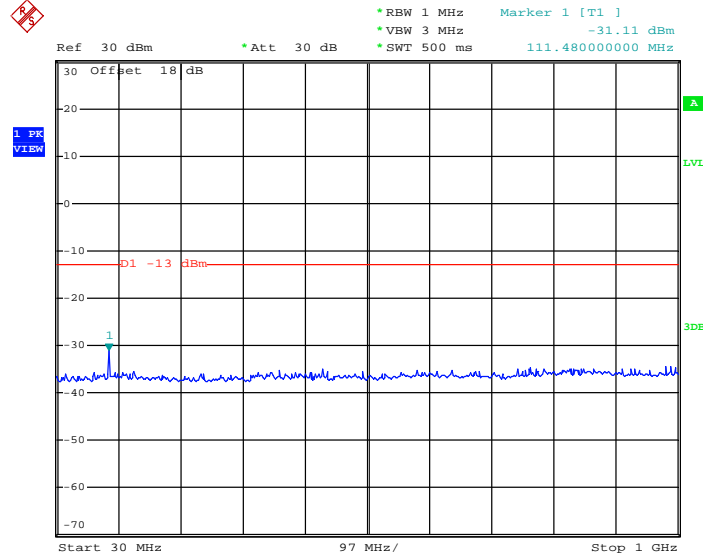

Date: 12.JAN.2014 10:46:13

Conducted Spurious Emission Plot between 1GHz ~ 3GHz

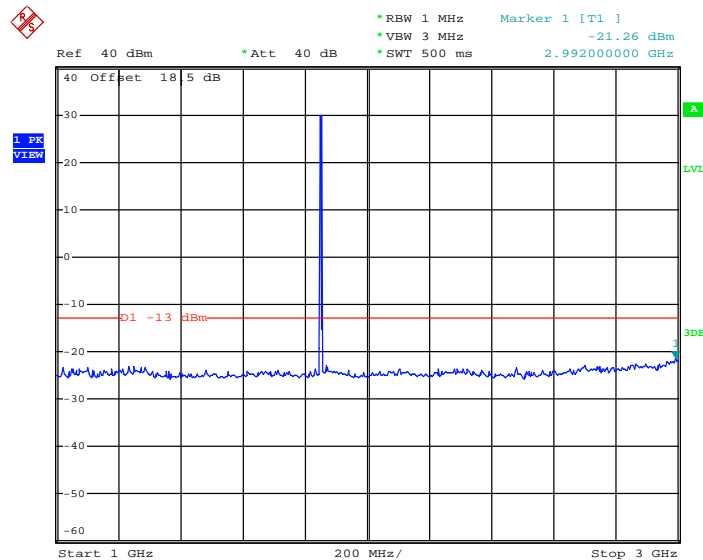

Date: 12.JAN.2014 10:48:02



### Conducted Spurious Emission Plot between 3GHz ~ 7GHz

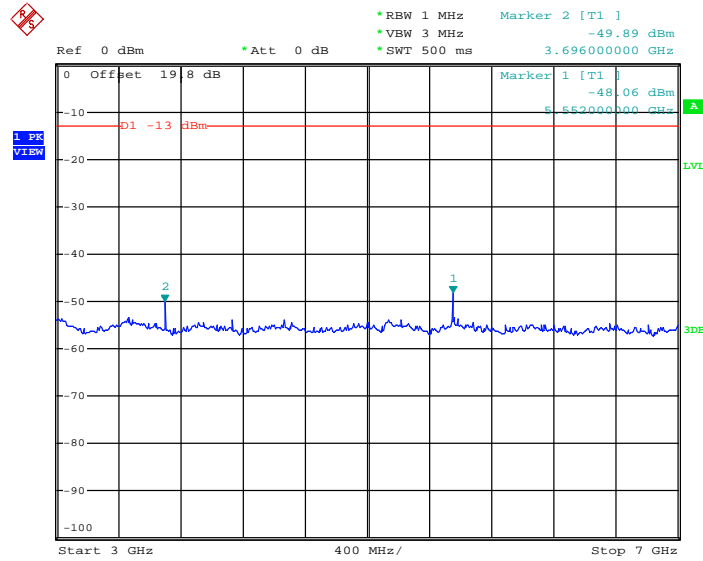

Date: 12.JAN.2014 10:20:47

### Conducted Emission Plot between 7GHz ~ 13.6GHz

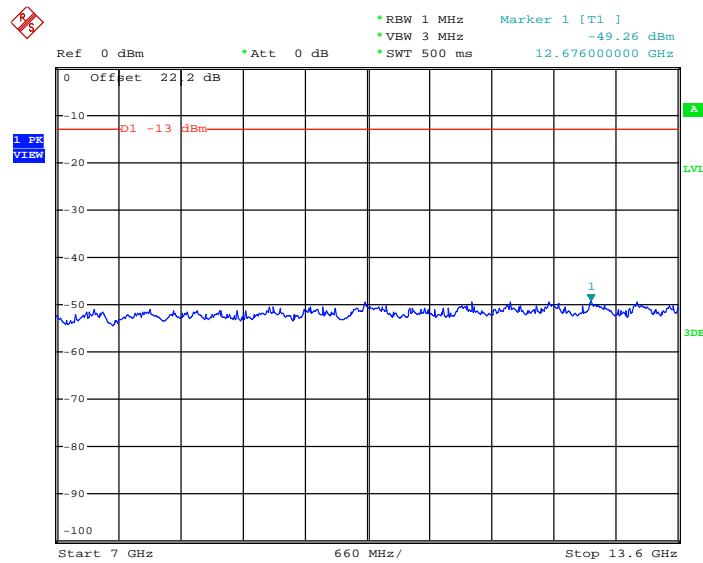

Date: 12.JAN.2014 10:36:53



Conducted Spurious Emission Plot between 13.6GHz ~ 19.1GHz

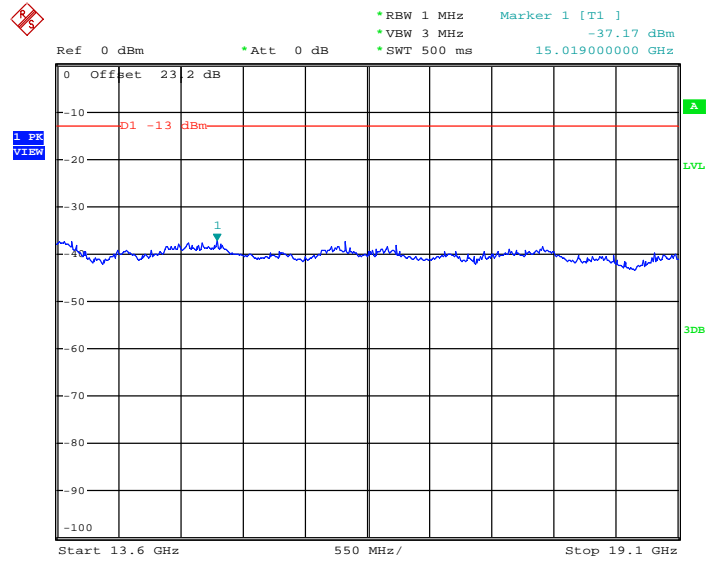

Date: 12.JAN.2014 10:39:07



Band :	GSM1900	Channel :	CH661
Test Mode :	GSM Link (GMSK)	Frequency :	1880.0 MHz

Conducted Spurious Emission Plot between 30MHz ~ 1GHz

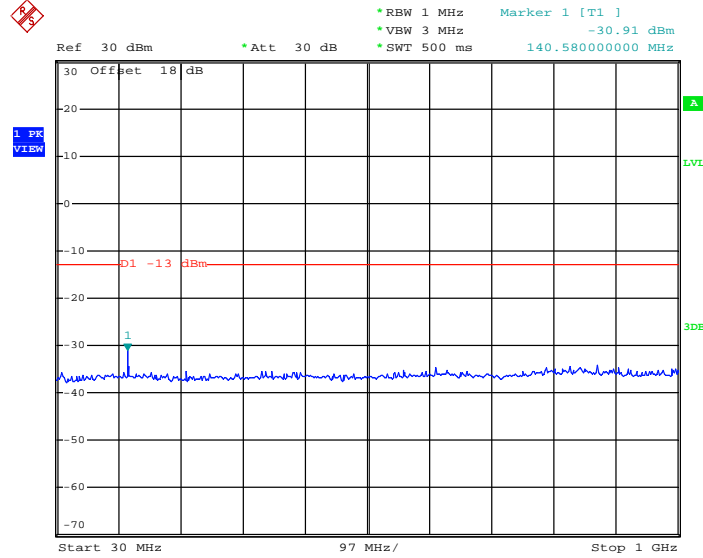

Date: 12.JAN.2014 10:45:14

Conducted Spurious Emission Plot between 1GHz ~ 3GHz

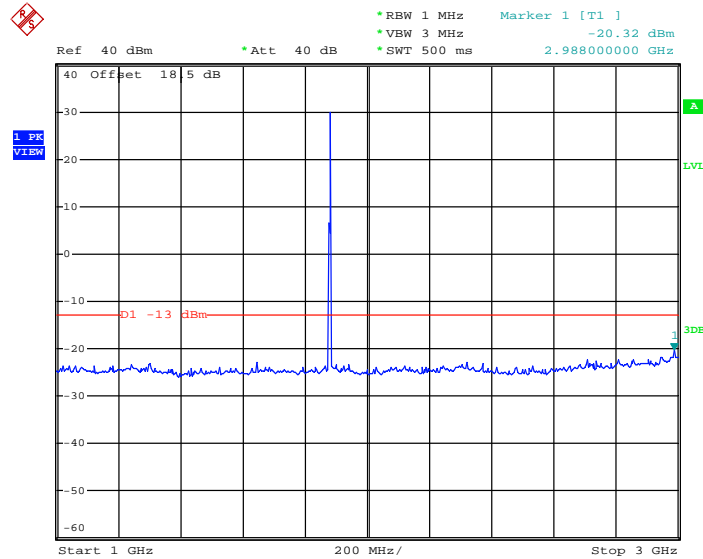

Date: 12.JAN.2014 10:49:22



### Conducted Spurious Emission Plot between 3GHz ~ 7GHz

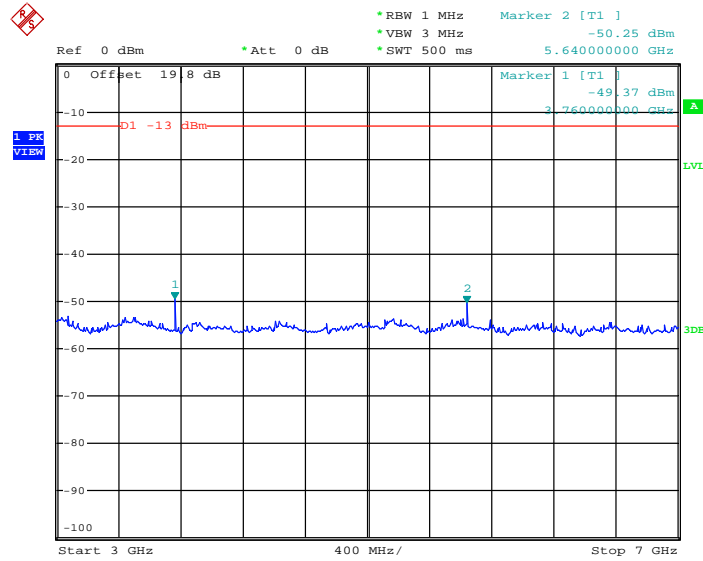

Date: 12.JAN.2014 10:22:07

### Conducted Emission Plot between 7GHz ~ 13.6GHz

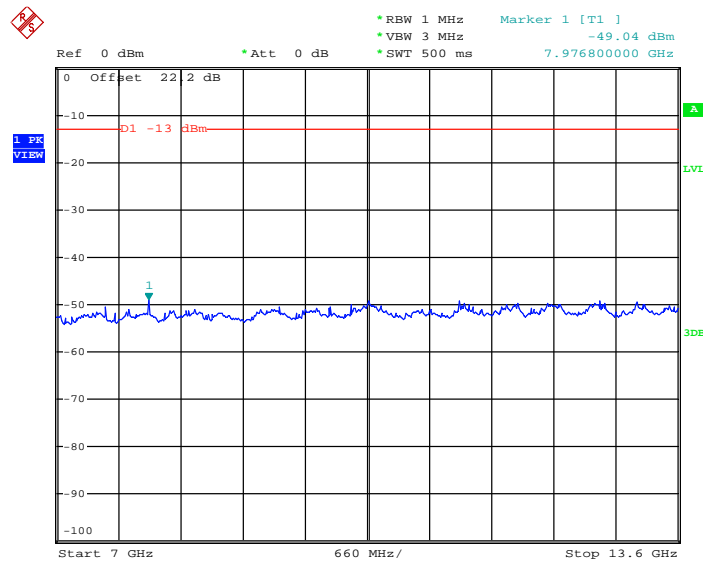

Date: 12.JAN.2014 10:35:45



Conducted Spurious Emission Plot between 13.6GHz ~ 19.1GHz

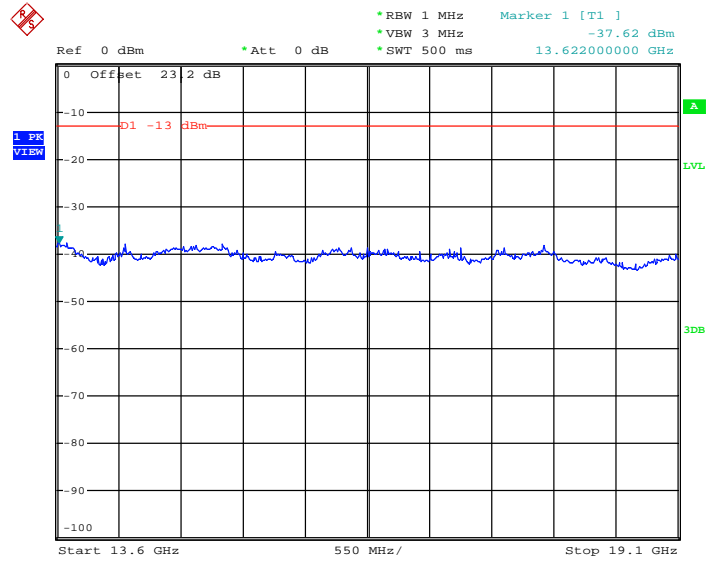

Date: 12.JAN.2014 10:39:58



Band :	GSM1900	Channel :	CH810
Test Mode :	GSM Link (GMSK)	Frequency :	1909.8 MHz

Conducted Spurious Emission Plot between 30MHz ~ 1GHz

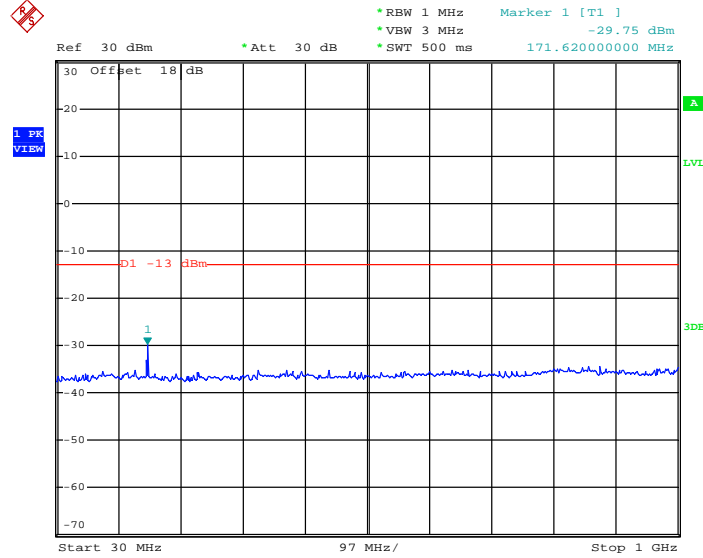

Date: 12.JAN.2014 10:43:43

Conducted Spurious Emission Plot between 1GHz ~ 3GHz

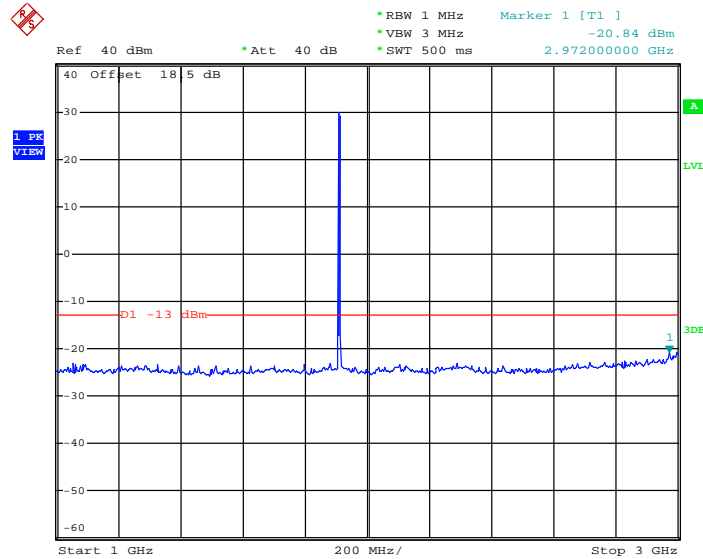

Date: 12.JAN.2014 10:52:56



### Conducted Spurious Emission Plot between 3GHz ~ 7GHz

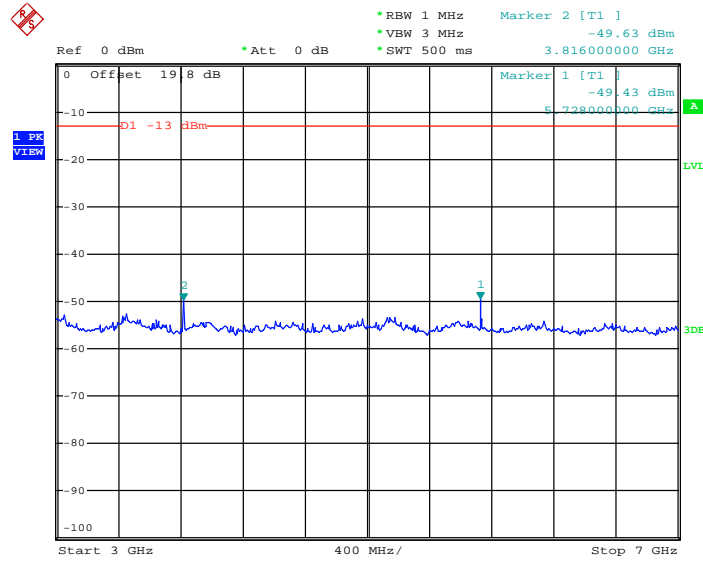

Date: 12.JAN.2014 10:23:22

### Conducted Emission Plot between 7GHz ~ 13.6GHz

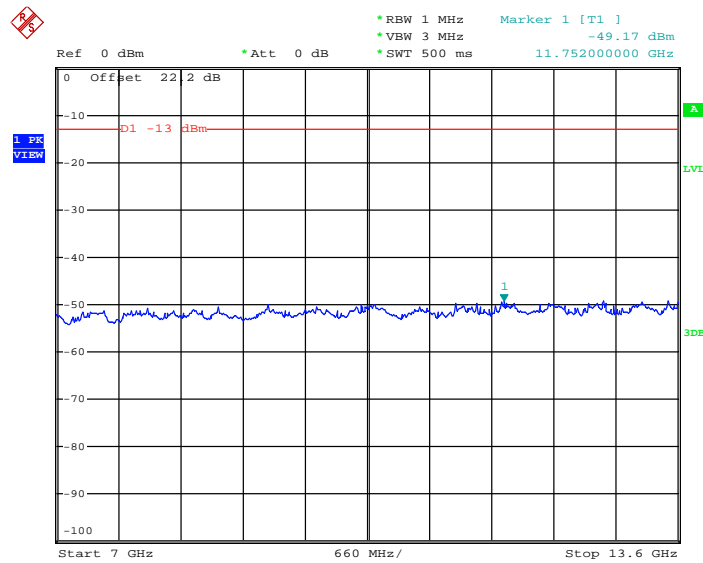

Date: 12.JAN.2014 10:34:25



Conducted Spurious Emission Plot between 13.6GHz ~ 19.1GHz

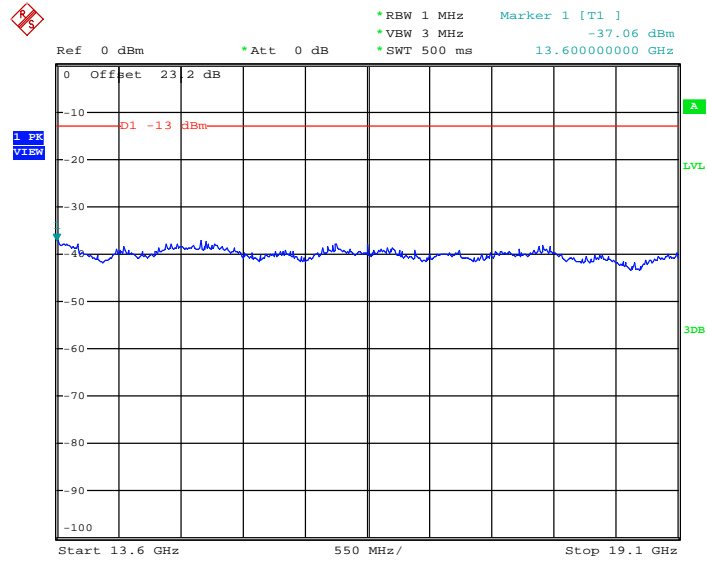

Date: 12.JAN.2014 10:41:11



Band :	GSM1900	Channel :	CH512
Test Mode :	EDGE class 8 Link (8PSK)	Frequency :	1850.2 MHz

Conducted Spurious Emission Plot between 30MHz ~ 1GHz

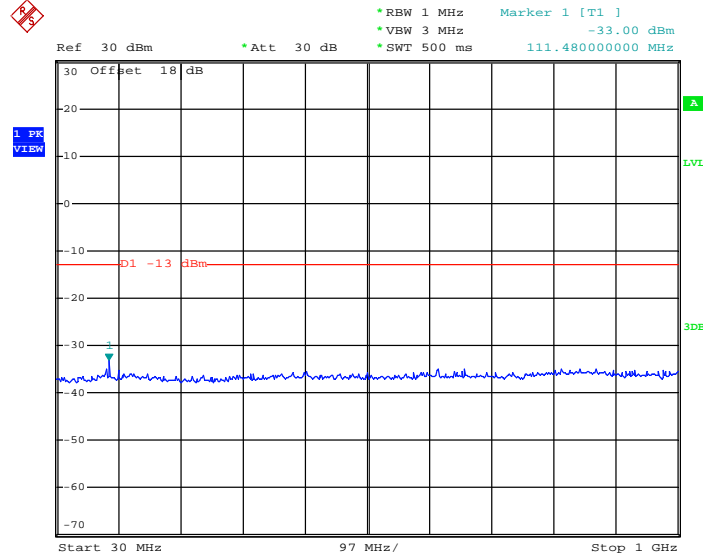

Date: 12.JAN.2014 12:24:50

Conducted Spurious Emission Plot between 1GHz ~ 3GHz

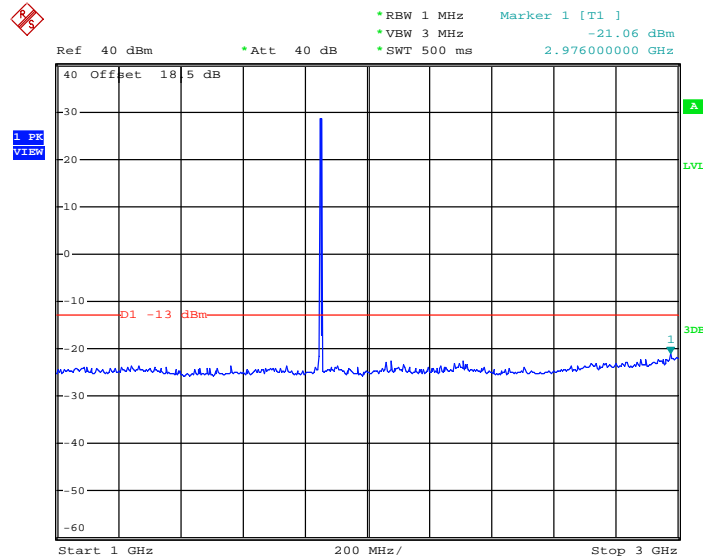

Date: 12.JAN.2014 12:26:30



### Conducted Spurious Emission Plot between 3GHz ~ 7GHz

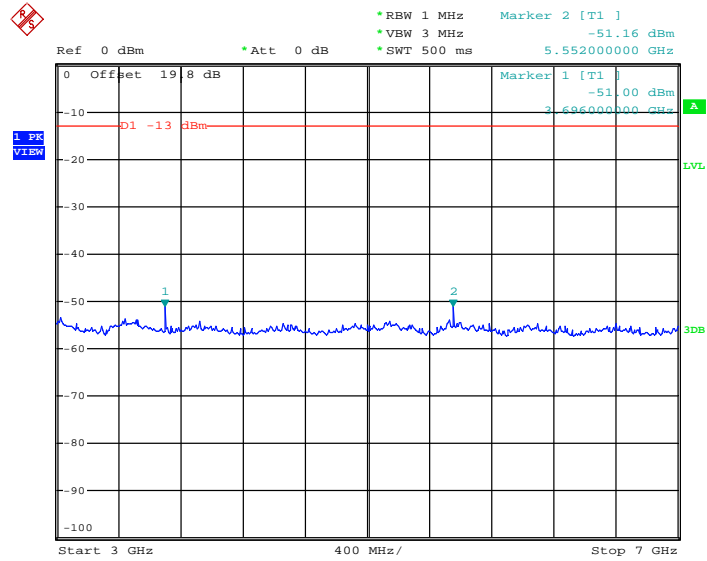

Date: 12.JAN.2014 12:36:15

### Conducted Spurious Emission Plot between 7GHz ~ 13.6GHz

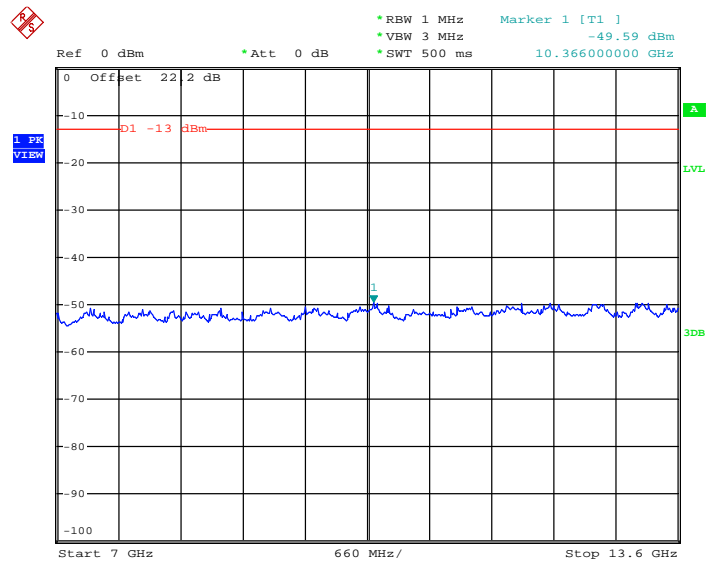

Date: 12.JAN.2014 12:37:58



Conducted Spurious Emission Plot between 13.6GHz ~ 19.1GHz

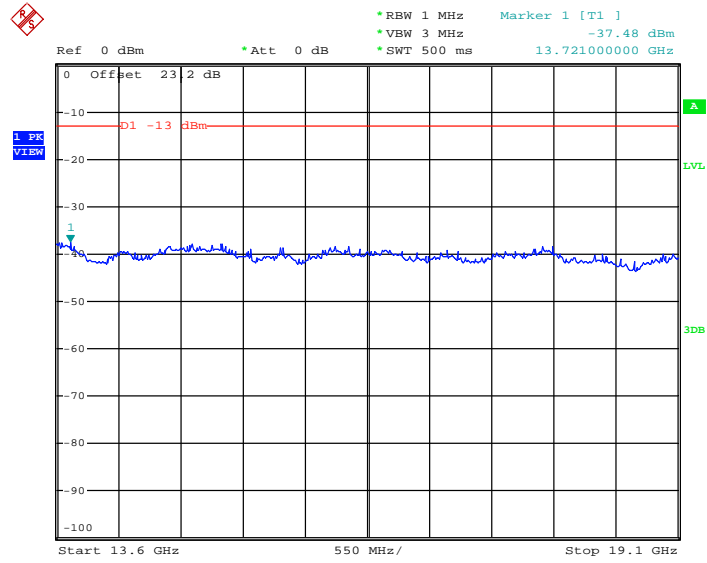

Date: 12.JAN.2014 12:43:13



Band :	GSM1900	Channel :	CH661
Test Mode :	EDGE class 8 Link (8PSK)	Frequency :	1880.0 MHz

Conducted Spurious Emission Plot between 30MHz ~ 1GHz

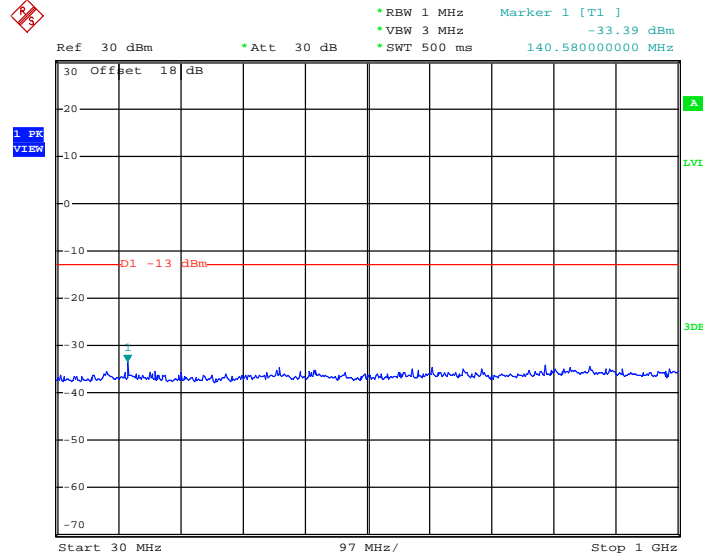

Date: 12.JAN.2014 12:24:02

Conducted Spurious Emission Plot between 1GHz ~ 3GHz

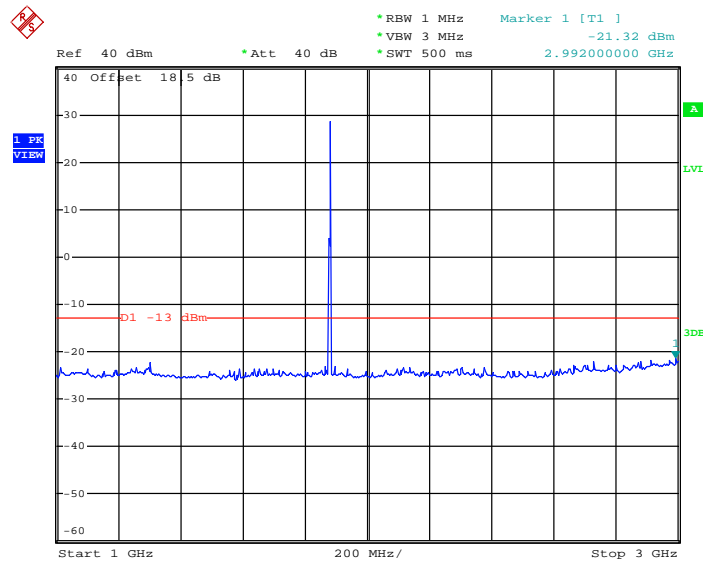

Date: 12.JAN.2014 12:27:53



### Conducted Spurious Emission Plot between 3GHz ~ 7GHz

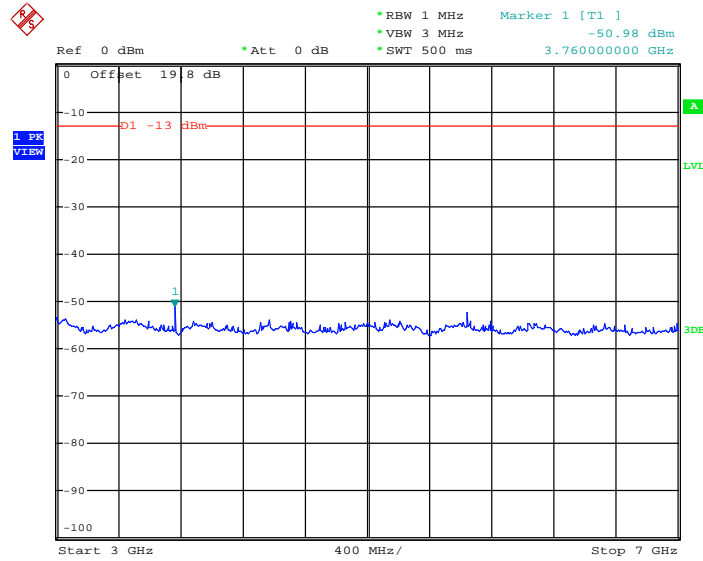

Date: 12.JAN.2014 12:35:03

### Conducted Spurious Emission Plot between 7GHz ~ 13.6GHz

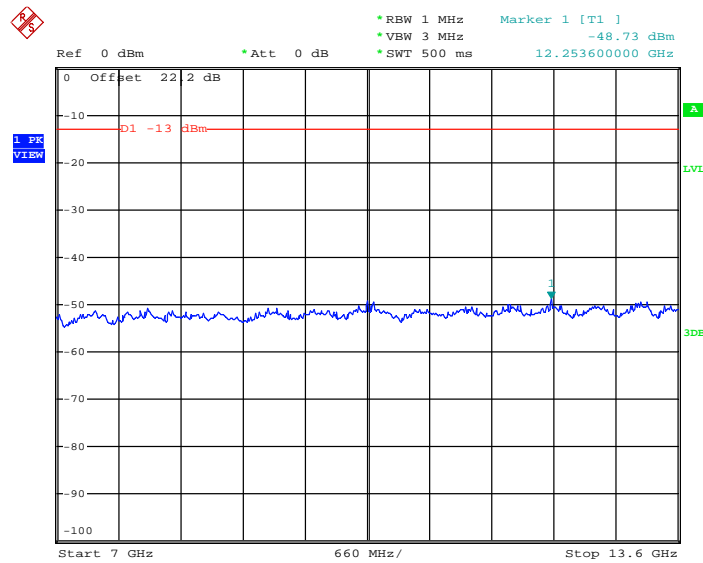

Date: 12.JAN.2014 12:38:52



Conducted Spurious Emission Plot between 13.6GHz ~ 19.1GHz

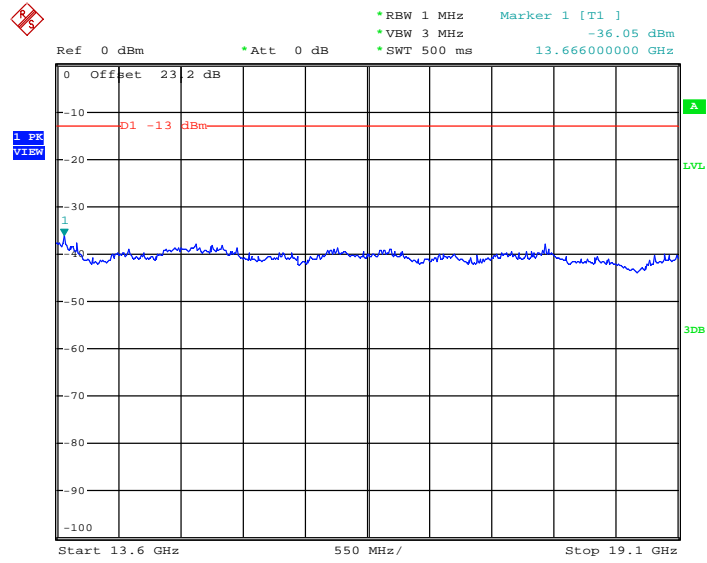

Date: 12.JAN.2014 12:42:08



Band :	GSM1900	Channel :	CH810
Test Mode :	EDGE class 8 Link (8PSK)	Frequency :	1909.8 MHz

Conducted Spurious Emission Plot between 30MHz ~ 1GHz

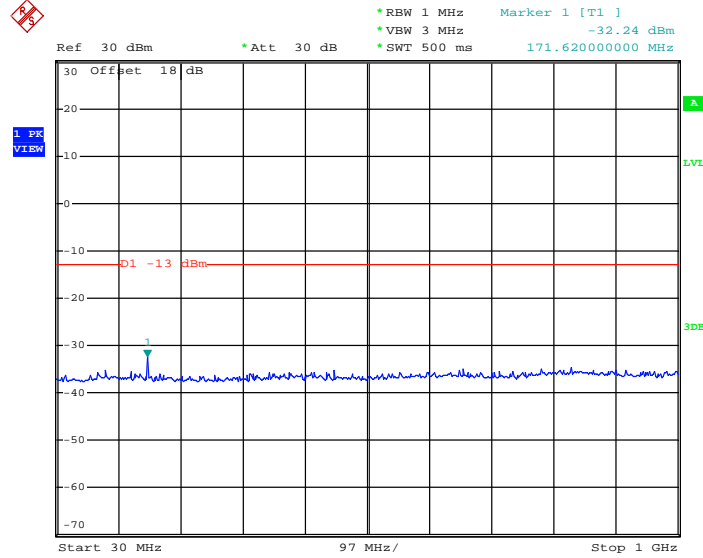

Date: 12.JAN.2014 12:22:53

Conducted Spurious Emission Plot between 1GHz ~ 3GHz

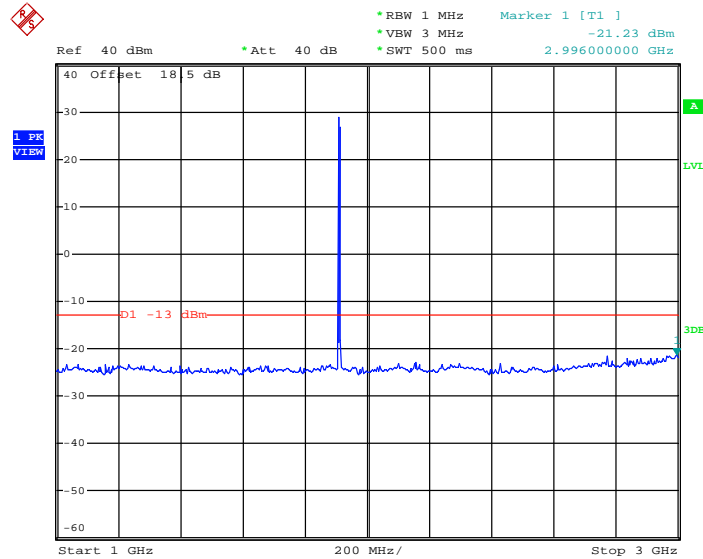

Date: 12.JAN.2014 12:30:29



### Conducted Spurious Emission Plot between 3GHz ~ 7GHz

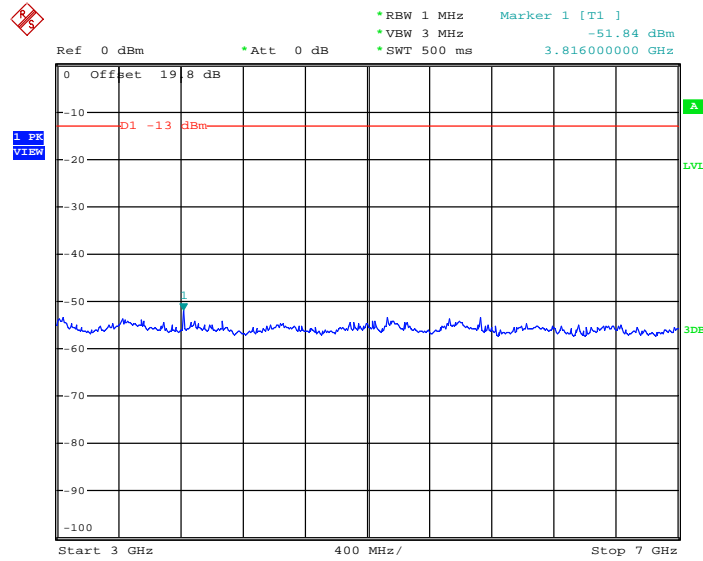

Date: 12.JAN.2014 12:32:58

### Conducted Spurious Emission Plot between 7GHz ~ 13.6GHz

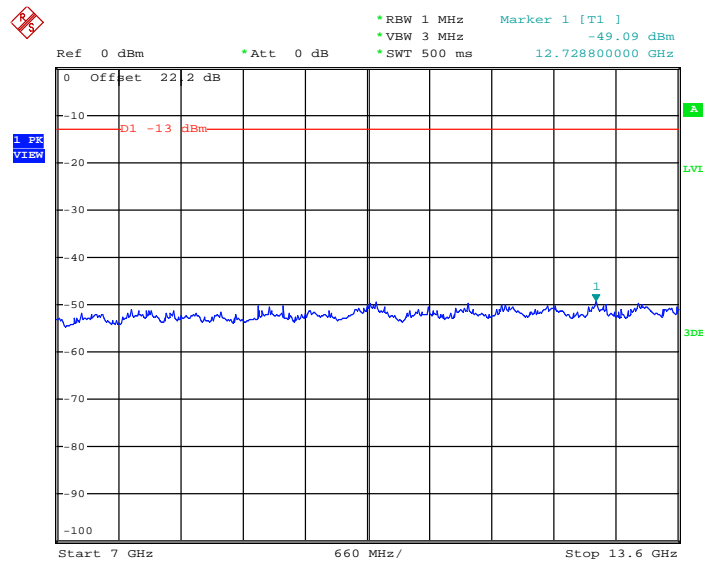

Date: 12.JAN.2014 12:39:35



Conducted Spurious Emission Plot between 13.6GHz ~ 19.1GHz

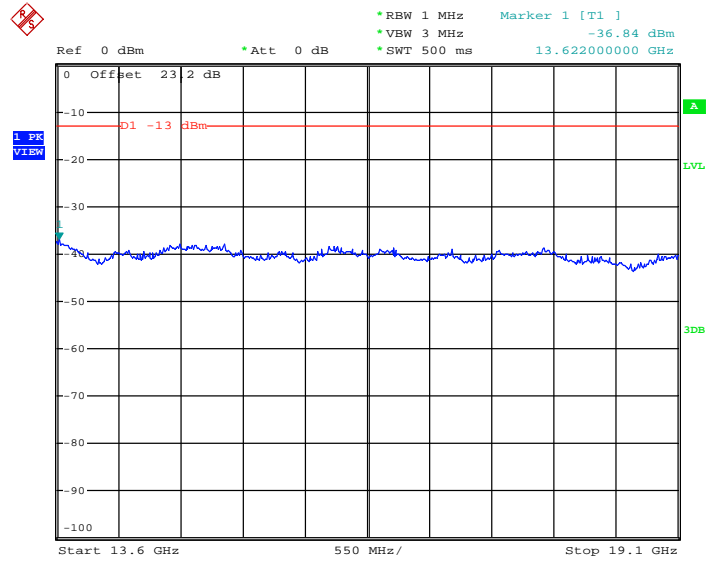

Date: 12.JAN.2014 12:41:30



Band :	WCDMA Band V	Channel :	CH4132
Test Mode :	RMC 12.2Kbps Link (QPSK)	Frequency :	826.4 MHz

Conducted Spurious Emission Plot between 30MHz ~ 1GHz

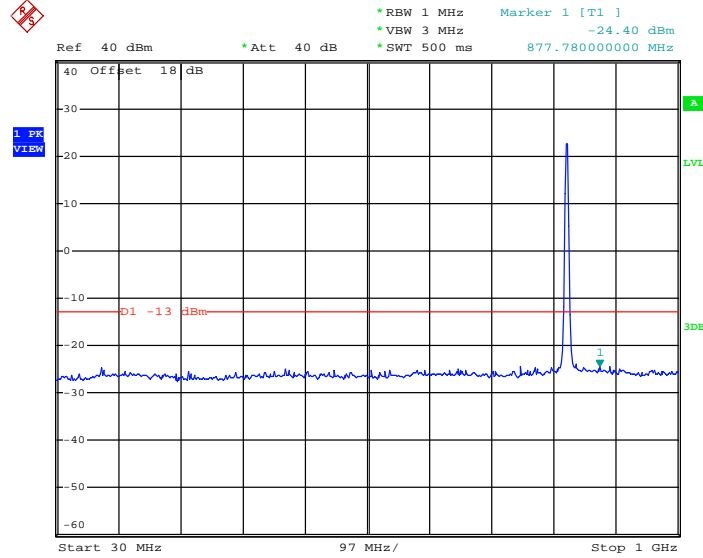

Date: 12.JAN.2014 14:03:00

Conducted Spurious Emission Plot between 1GHz ~ 3GHz

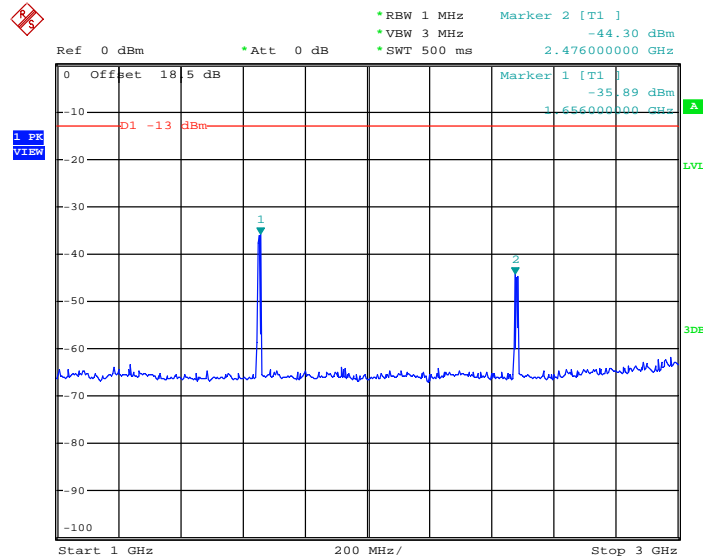

Date: 12.JAN.2014 14:10:20



### Conducted Spurious Emission Plot between 3GHz ~ 7GHz

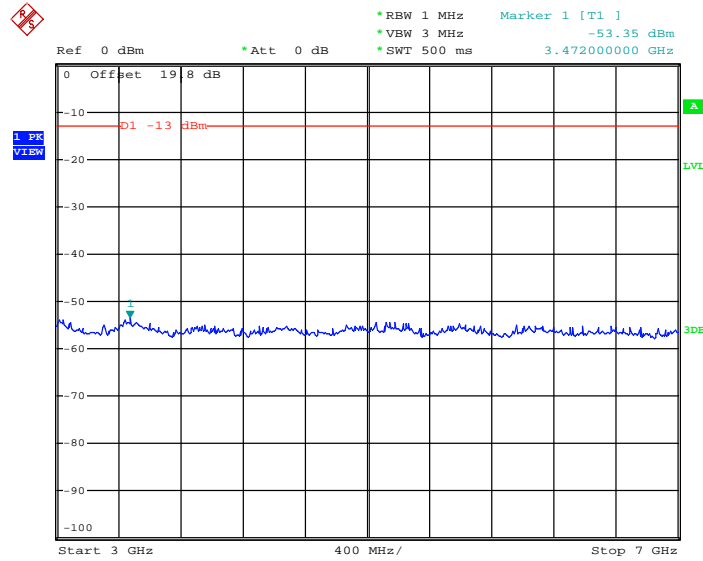

Date: 12.JAN.2014 14:12:47

### Conducted Spurious Emission Plot between 7GHz ~ 9GHz

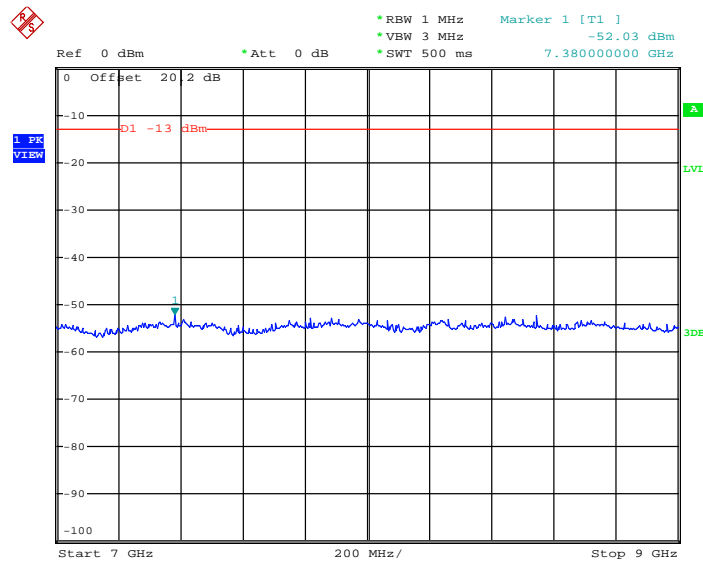

Date: 12.JAN.2014 14:15:37



Band :	WCDMA Band V	Channel :	CH4182
Test Mode :	RMC 12.2Kbps Link (QPSK)	Frequency :	836.4 MHz

Conducted Spurious Emission Plot between 30MHz ~ 1GHz

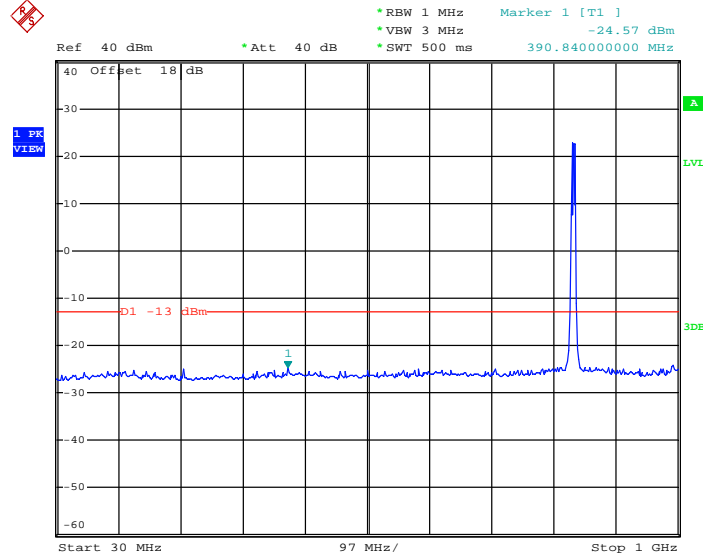

Date: 12.JAN.2014 14:05:03

Conducted Spurious Emission Plot between 1GHz ~ 3GHz

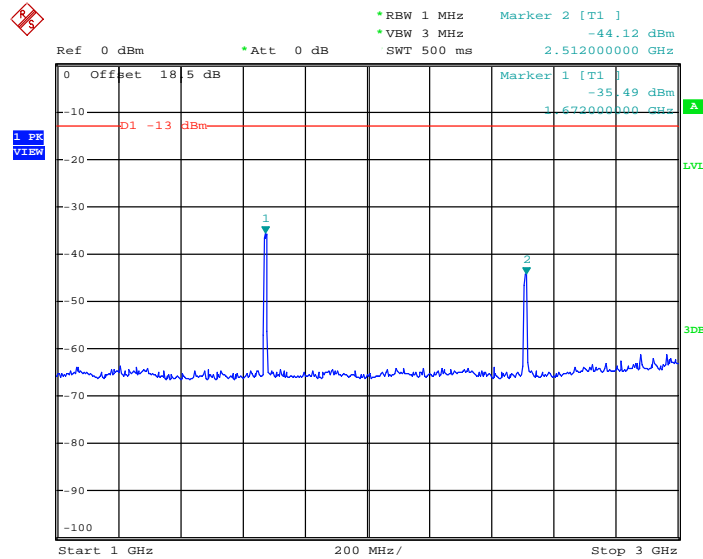

Date: 12.JAN.2014 14:07:56



### Conducted Spurious Emission Plot between 3GHz ~ 7GHz

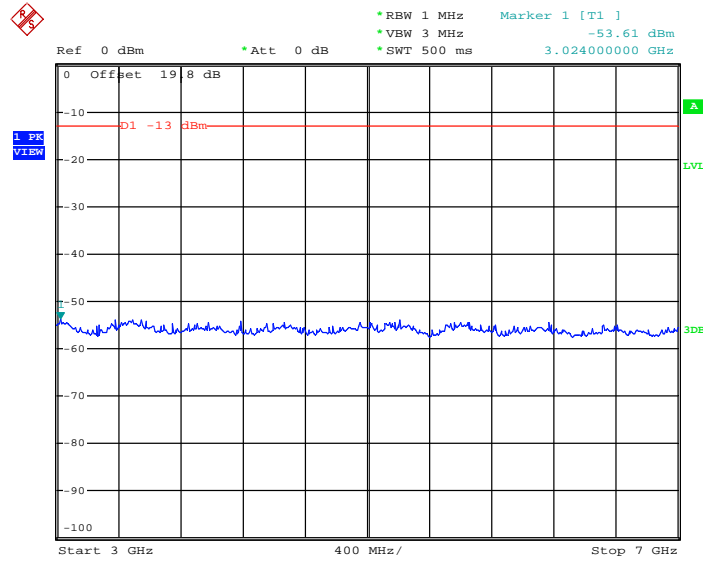

Date: 12.JAN.2014 14:13:28

### Conducted Spurious Emission Plot between 7GHz ~ 9GHz

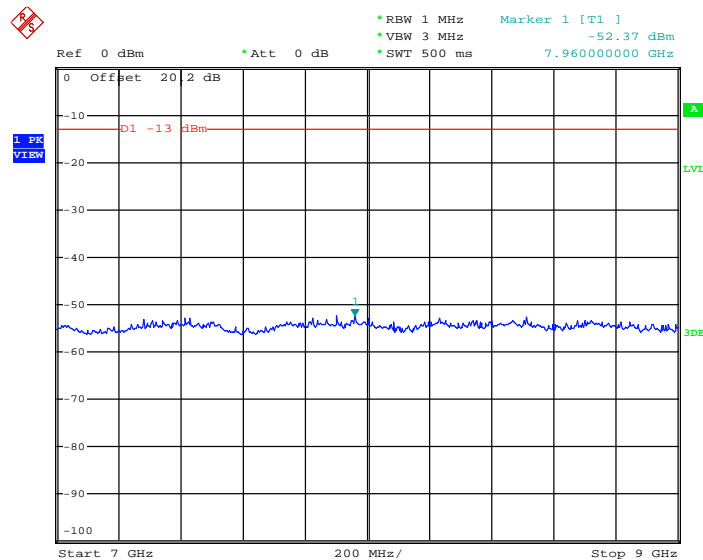

Date: 12.JAN.2014 14:14:34



Band :	WCDMA Band V	Channel :	CH4233
Test Mode :	RMC 12.2Kbps Link (QPSK)	Frequency :	846.6 MHz

Conducted Spurious Emission Plot between 30MHz ~ 1GHz

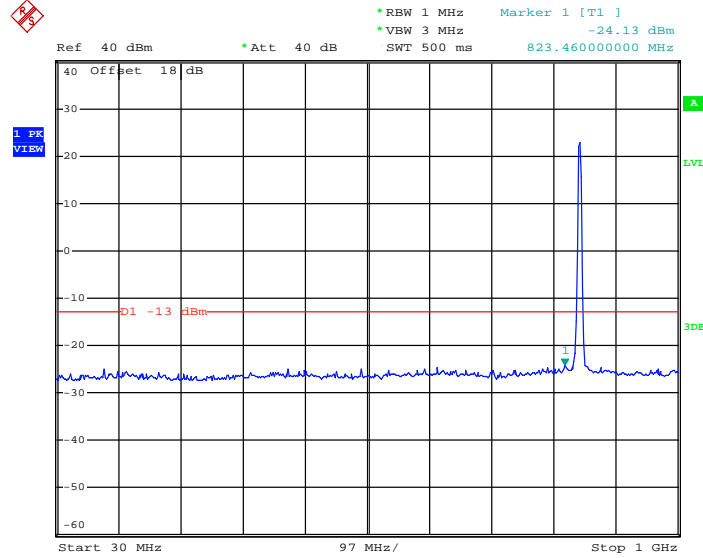

Date: 12.JAN.2014 14:00:49

Conducted Spurious Emission Plot between 1GHz ~ 3GHz

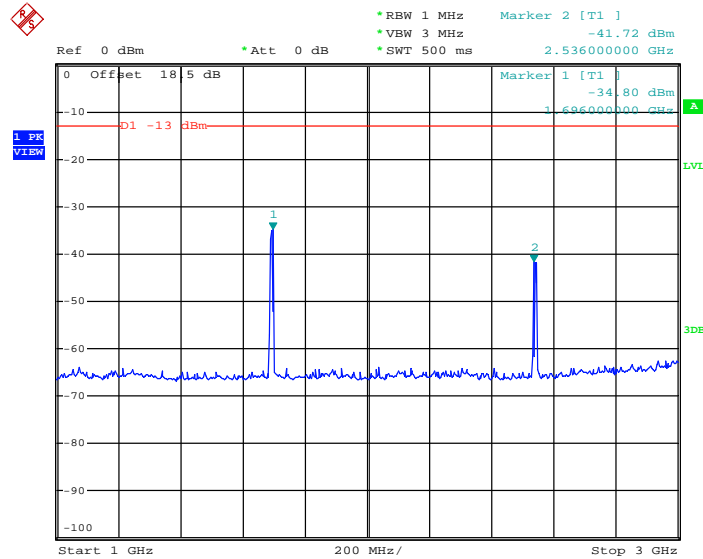

Date: 12.JAN.2014 14:11:17



### Conducted Spurious Emission Plot between 3GHz ~ 7GHz

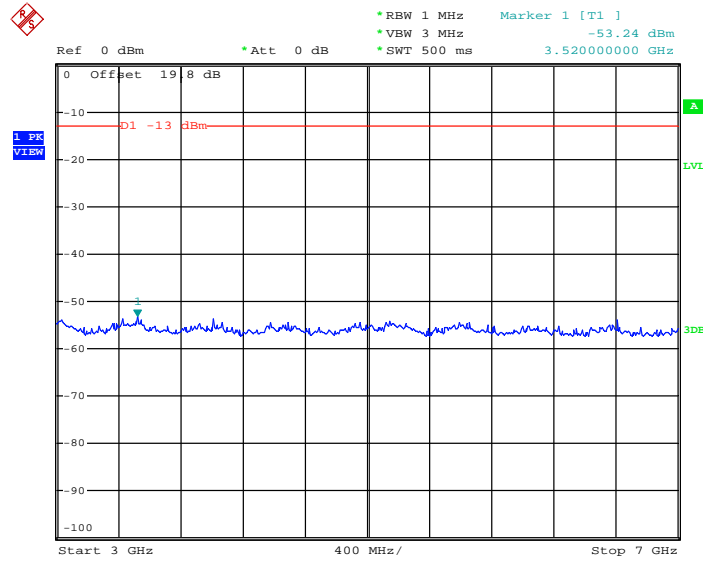

Date: 12.JAN.2014 14:12:15

### Conducted Spurious Emission Plot between 7GHz ~ 9GHz

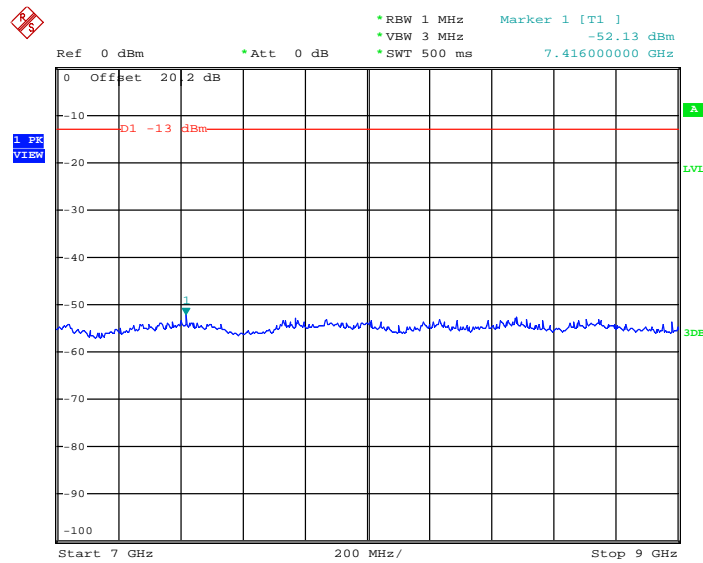

Date: 12.JAN.2014 14:16:17



Band :	WCDMA Band II	Channel :	CH9262
Test Mode :	RMC 12.2Kbps Link (QPSK)	Frequency :	1852.4 MHz

Conducted Spurious Emission Plot between 30MHz ~ 1GHz

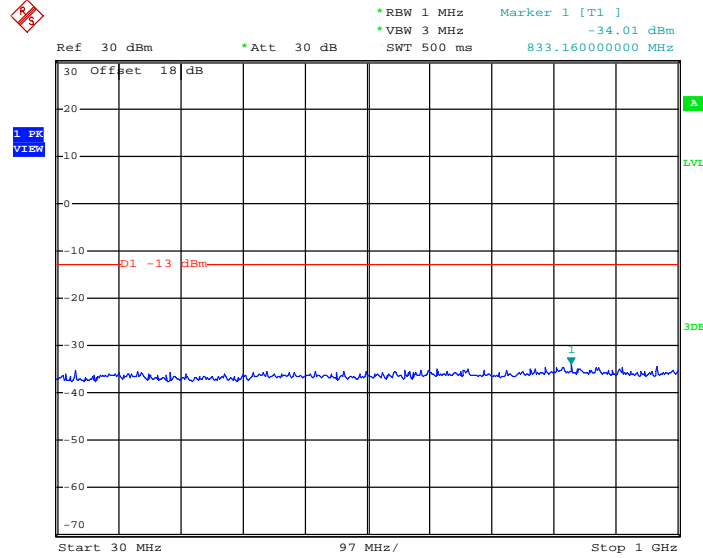

Date: 12.JAN.2014 14:33:41

Conducted Spurious Emission Plot between 1GHz ~ 3GHz

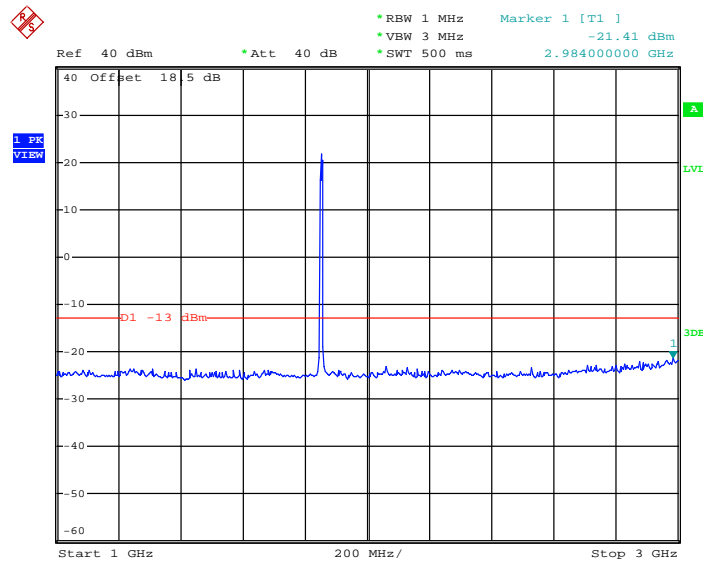

Date: 12.JAN.2014 14:39:08



### Conducted Spurious Emission Plot between 3GHz ~ 7GHz

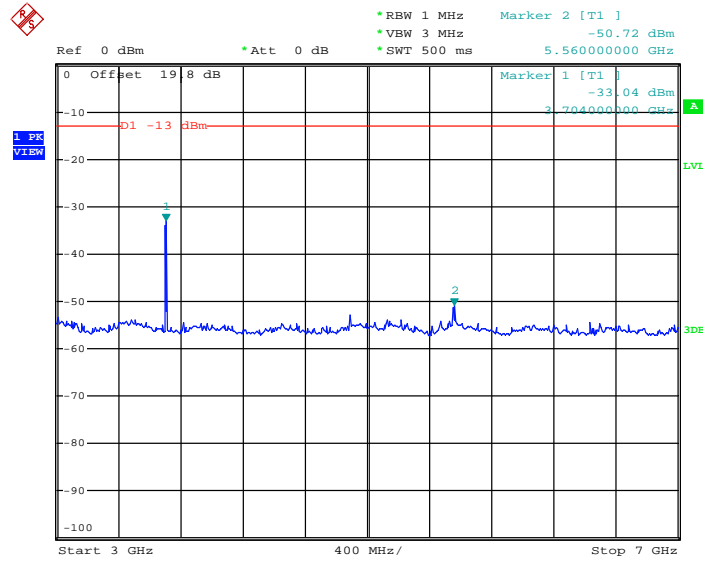

Date: 12.JAN.2014 14:22:18

### Conducted Spurious Emission Plot between 7GHz ~ 13.6GHz

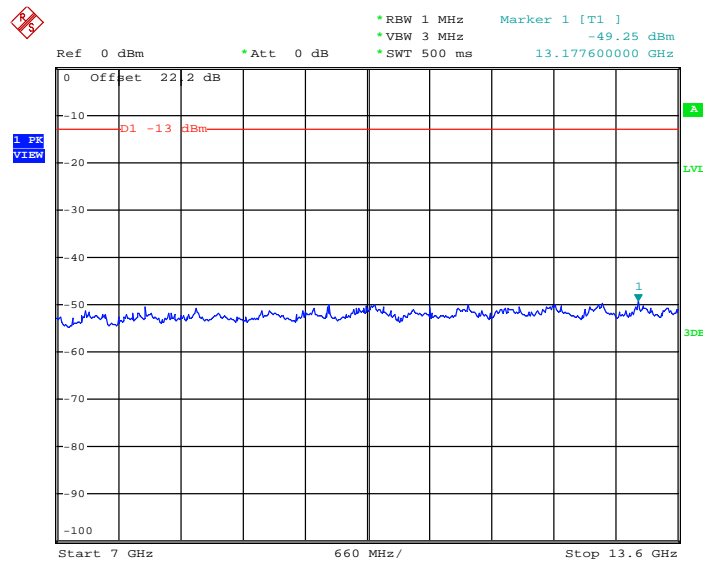

Date: 12.JAN.2014 14:26:01



Conducted Spurious Emission Plot between 13.6GHz ~ 19.1GHz

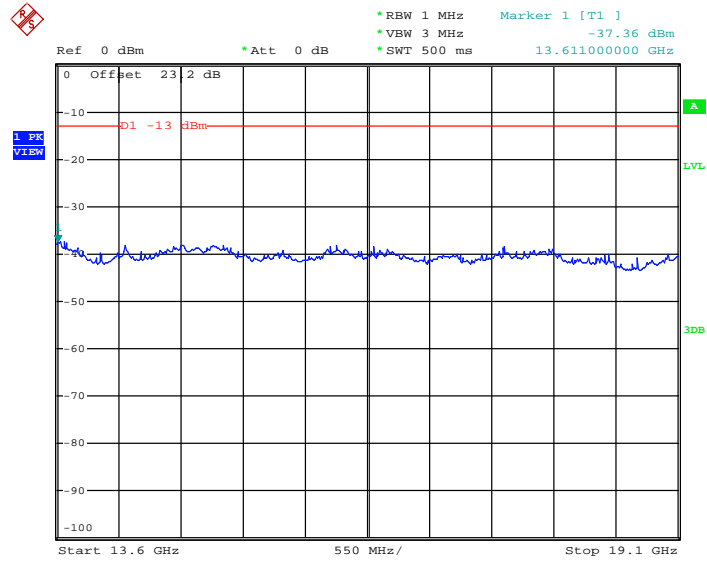

Date: 12.JAN.2014 14:28:31



Band :	WCDMA Band II	Channel :	CH9400
Test Mode :	RMC 12.2Kbps Link (QPSK)	Frequency :	1880.0 MHz

Conducted Spurious Emission Plot between 30MHz ~ 1GHz

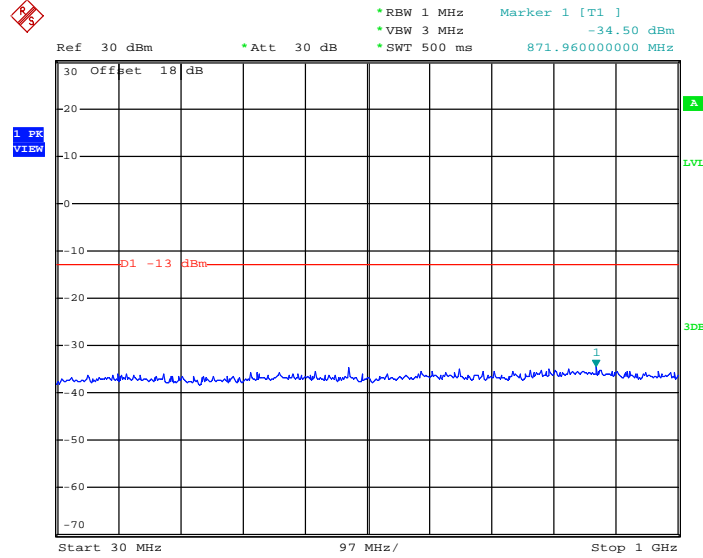

Date: 12.JAN.2014 14:34:20

Conducted Spurious Emission Plot between 1GHz ~ 3GHz

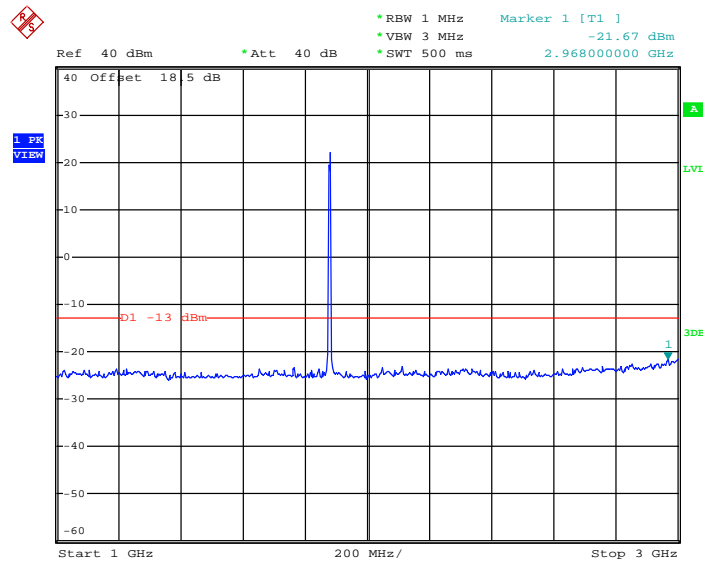

Date: 12.JAN.2014 14:40:13



### Conducted Spurious Emission Plot between 3GHz ~ 7GHz

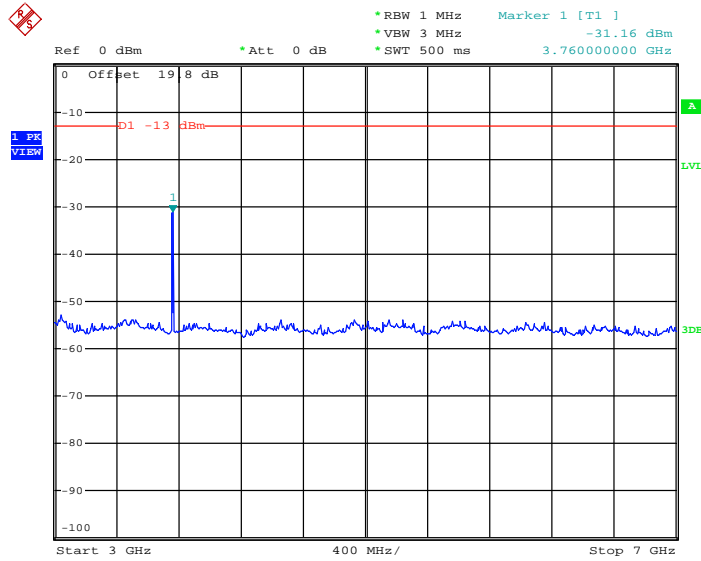

Date: 12.JAN.2014 14:21:12

### Conducted Spurious Emission Plot between 7GHz ~ 13.6GHz

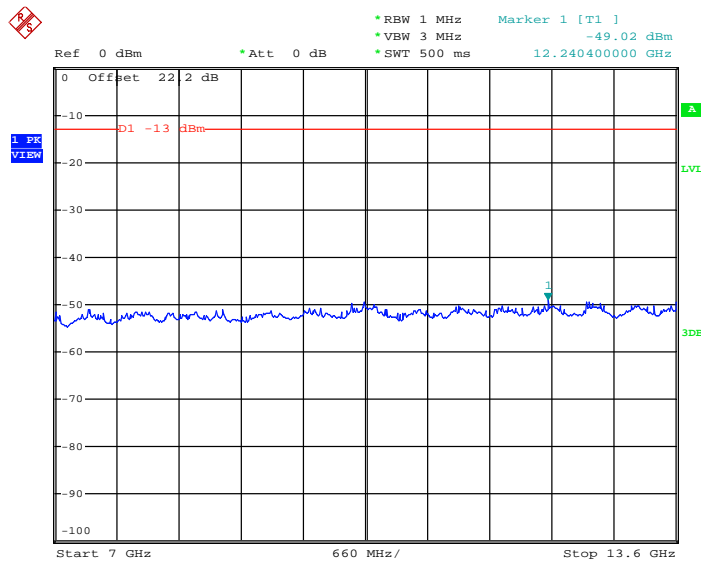

Date: 12.JAN.2014 14:26:53



Conducted Spurious Emission Plot between 13.6GHz ~ 19.1GHz

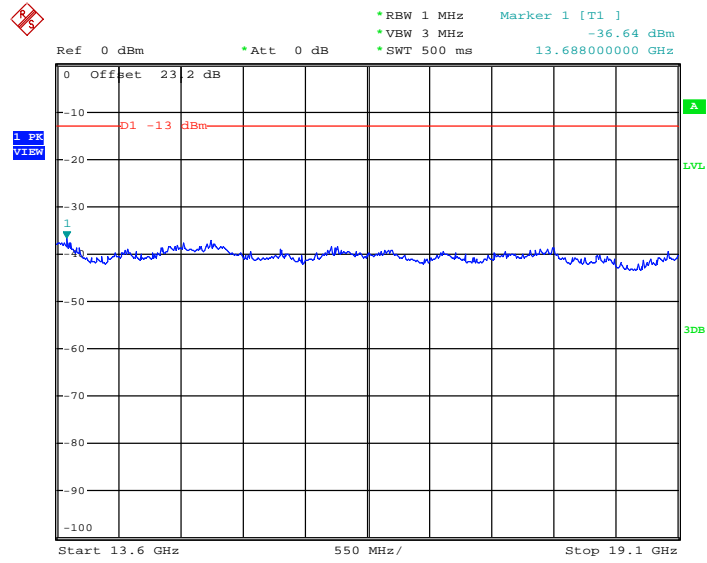

Date: 12.JAN.2014 14:27:51



Band :	WCDMA Band II	Channel :	CH9538
Test Mode :	RMC 12.2Kbps Link (QPSK)	Frequency :	1907.6 MHz

Conducted Spurious Emission Plot between 30MHz ~ 1GHz

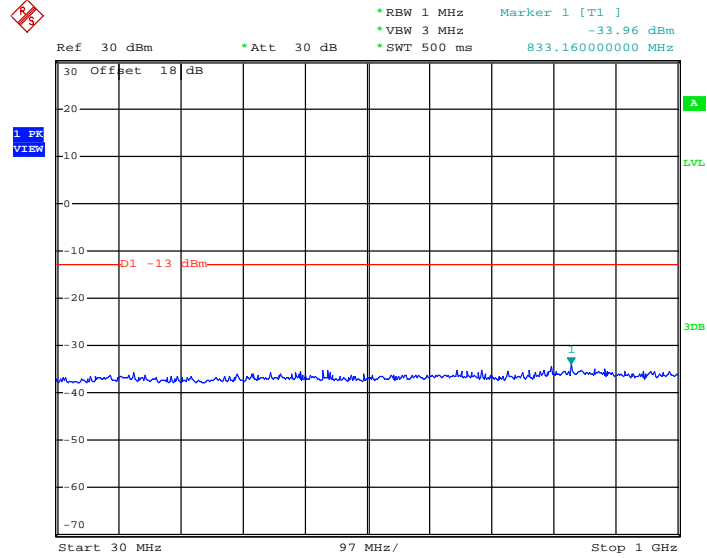

Date: 12.JAN.2014 14:35:36

Conducted Spurious Emission Plot between 1GHz ~ 3GHz

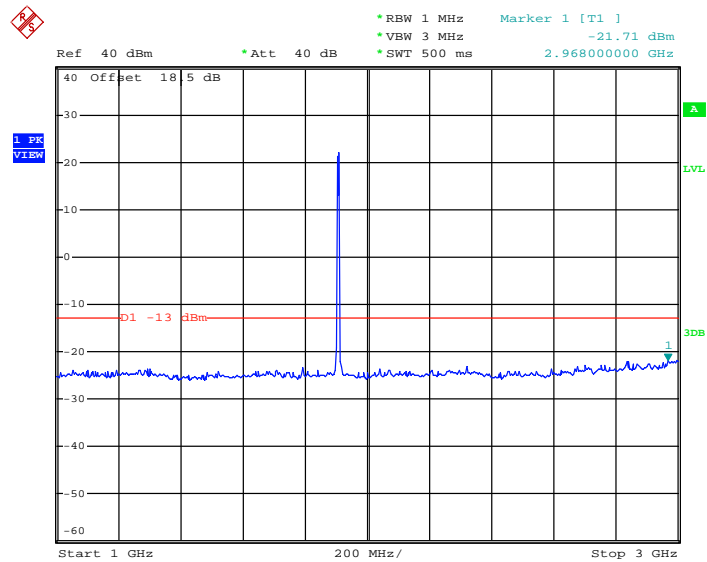

Date: 12.JAN.2014 14:37:56



### Conducted Spurious Emission Plot between 3GHz ~ 7GHz

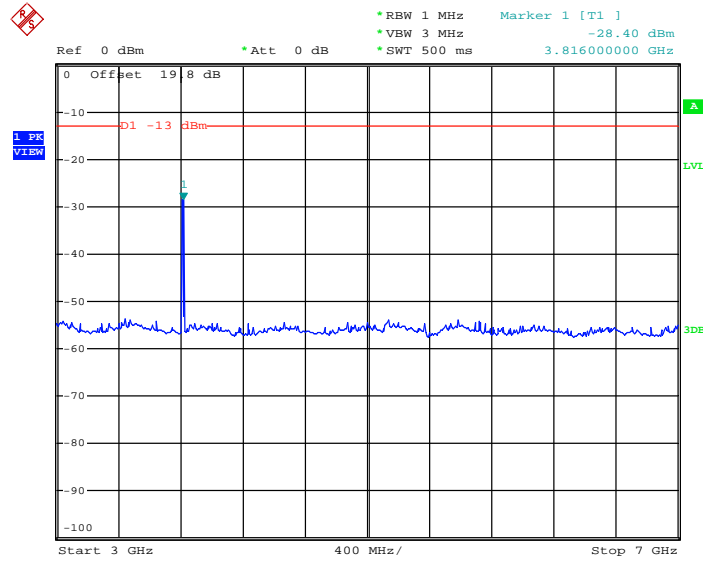

Date: 12.JAN.2014 14:23:08

### Conducted Spurious Emission Plot between 7GHz ~ 13.6GHz

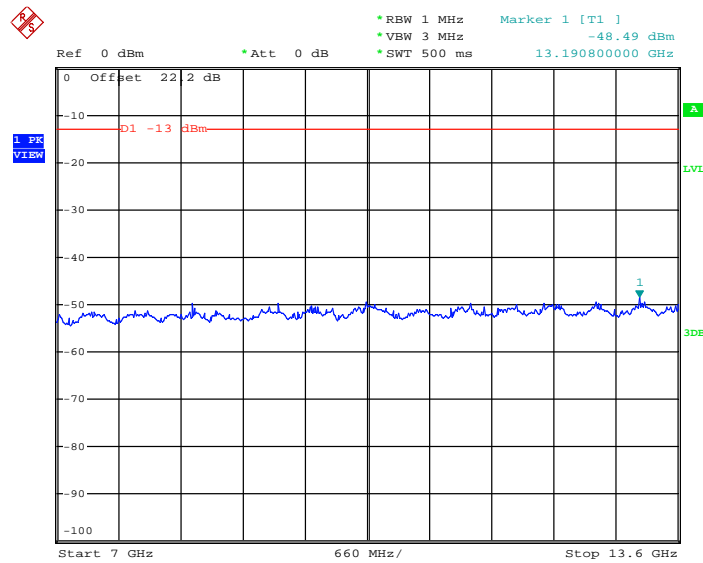

Date: 12.JAN.2014 14:25:23



Conducted Spurious Emission Plot between 13.6GHz ~ 19.1GHz

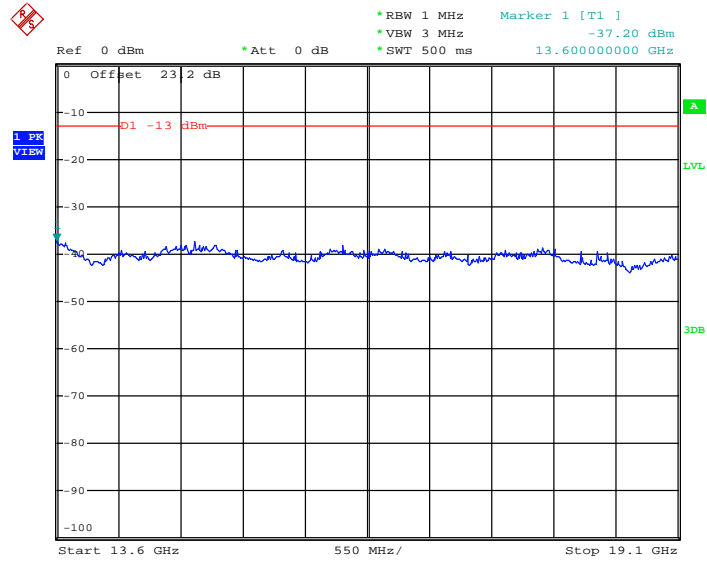

Date: 12.JAN.2014 14:30:10



SIM2 Card:

Band :	GSM1900	Channel :	CH512
Test Mode :	GSM Link (GMSK)	Frequency :	1850.2 MHz

Conducted Spurious Emission Plot between 30MHz ~ 1GHz

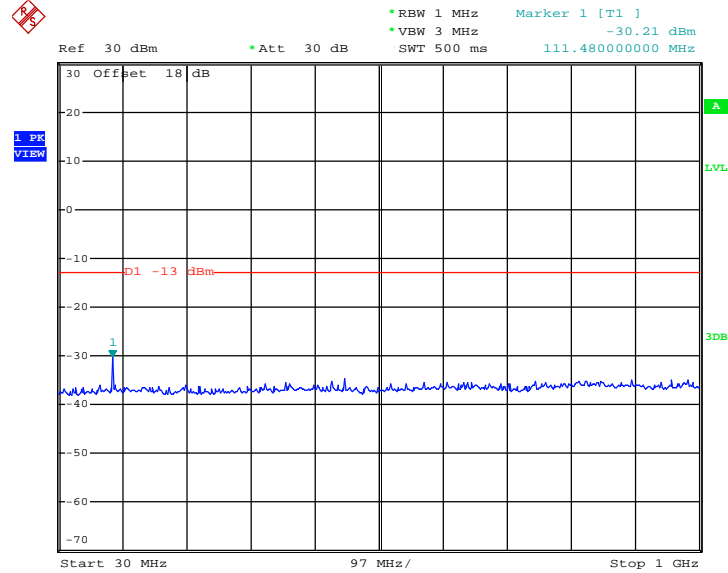

Date: 8.FEB.2014 11:00:19

Conducted Spurious Emission Plot between 1GHz ~ 3GHz

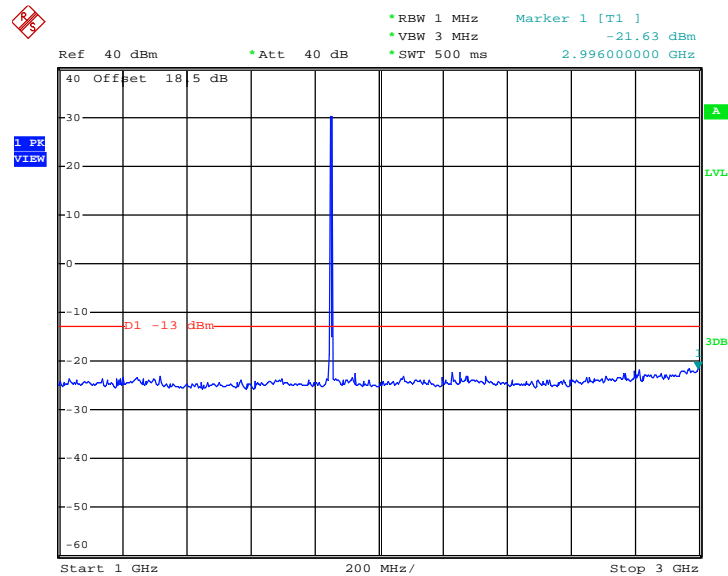

Date: 8.FEB.2014 10:59:14



### Conducted Spurious Emission Plot between 3GHz ~ 7GHz

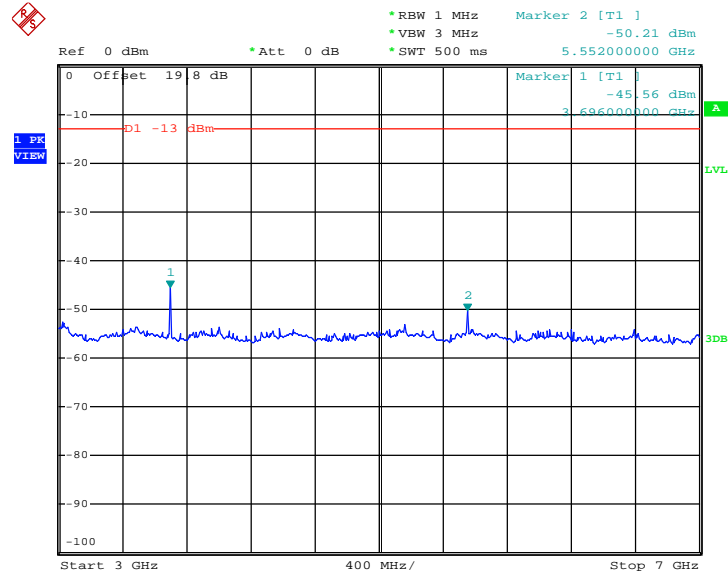

Date: 8.FEB.2014 10:48:56

### Conducted Emission Plot between 7GHz ~ 13.6GHz

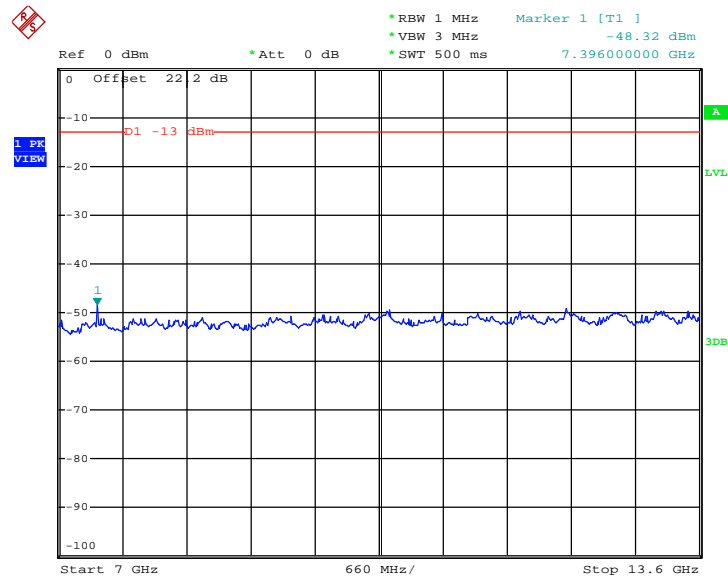

Date: 8.FEB.2014 10:47:13



Conducted Spurious Emission Plot between 13.6GHz ~ 19.1GHz

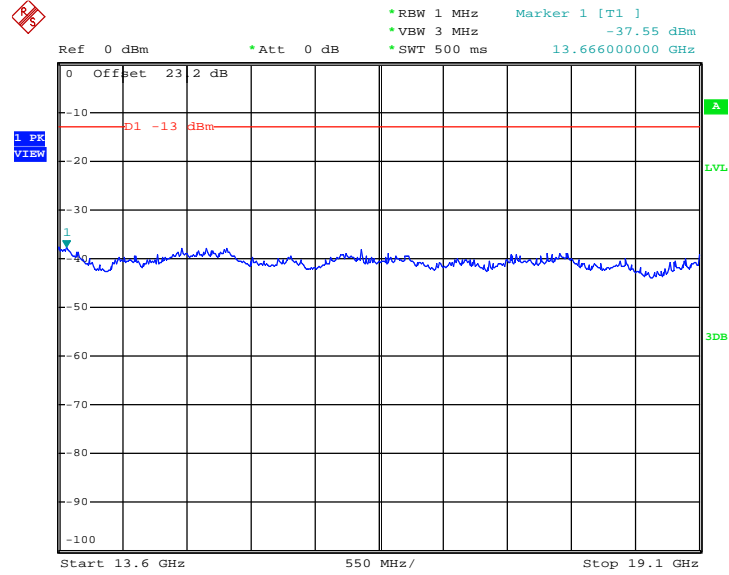

Date: 8.FEB.2014 10:42:19



Band :	GSM1900	Channel :	CH661
Test Mode :	GSM Link (GMSK)	Frequency :	1880.0 MHz

Conducted Spurious Emission Plot between 30MHz ~ 1GHz

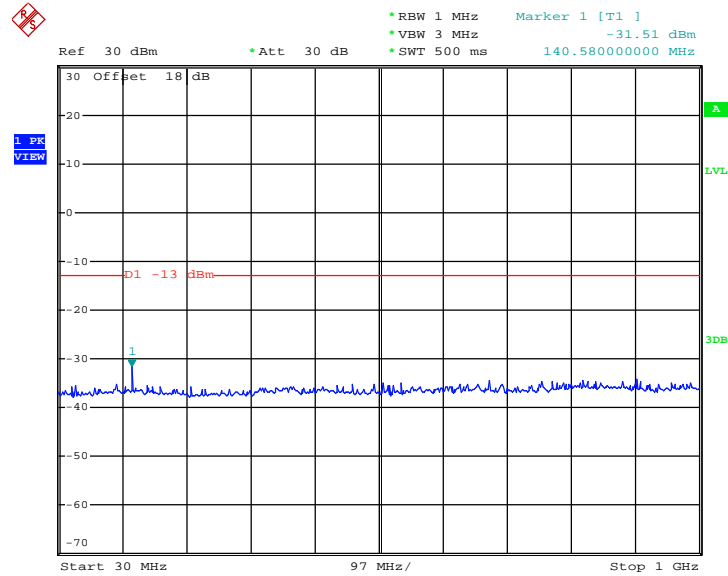

Date: 8.FEB.2014 11:00:52

Conducted Spurious Emission Plot between 1GHz ~ 3GHz

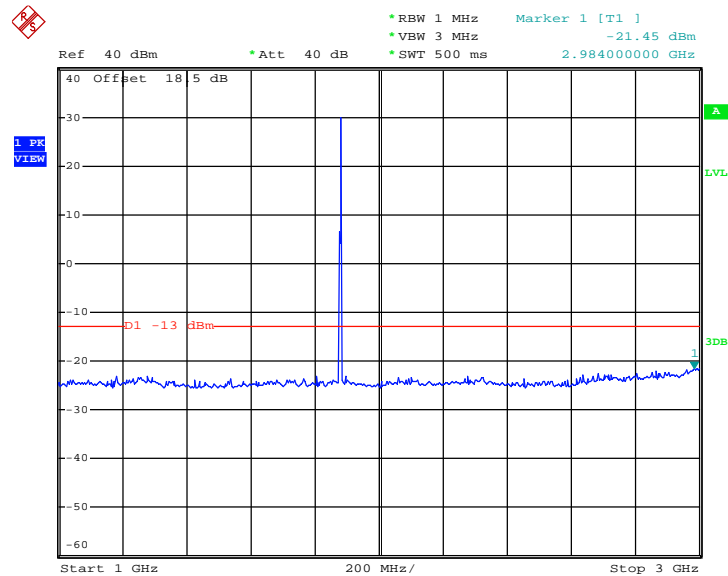

Date: 8.FEB.2014 10:57:41



### Conducted Spurious Emission Plot between 3GHz ~ 7GHz

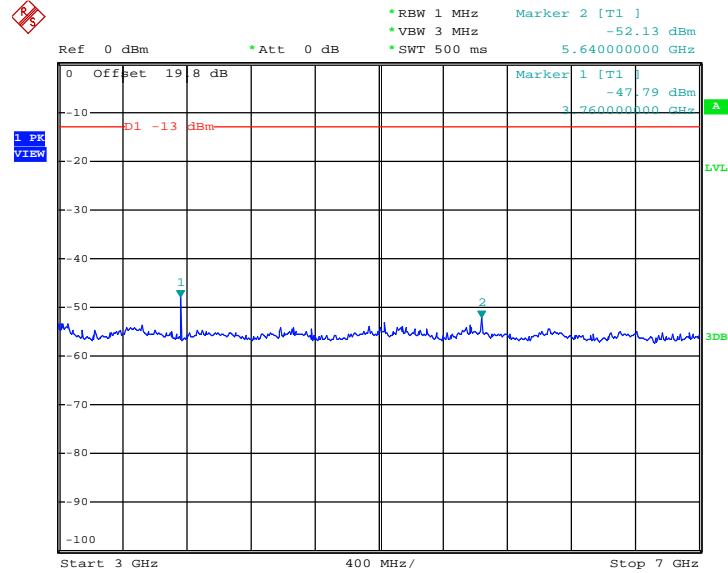

Date: 8.FEB.2014 10:49:51

### Conducted Emission Plot between 7GHz ~ 13.6GHz

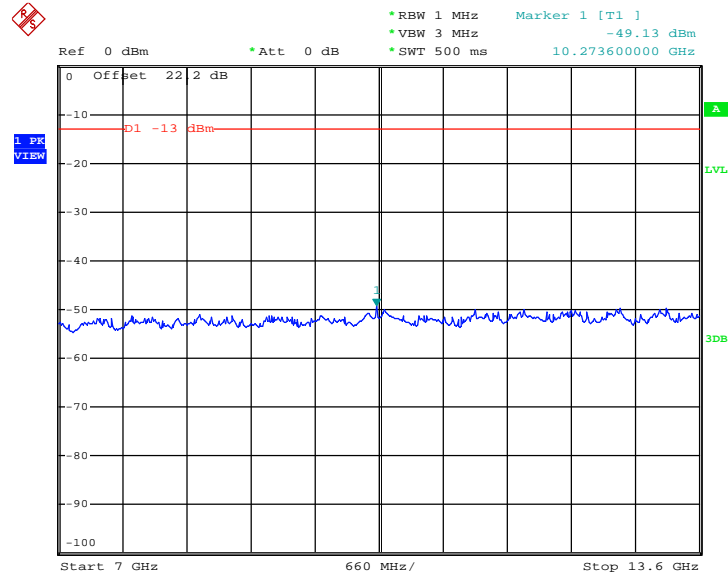

Date: 8.FEB.2014 10:46:26



Conducted Spurious Emission Plot between 13.6GHz ~ 19.1GHz

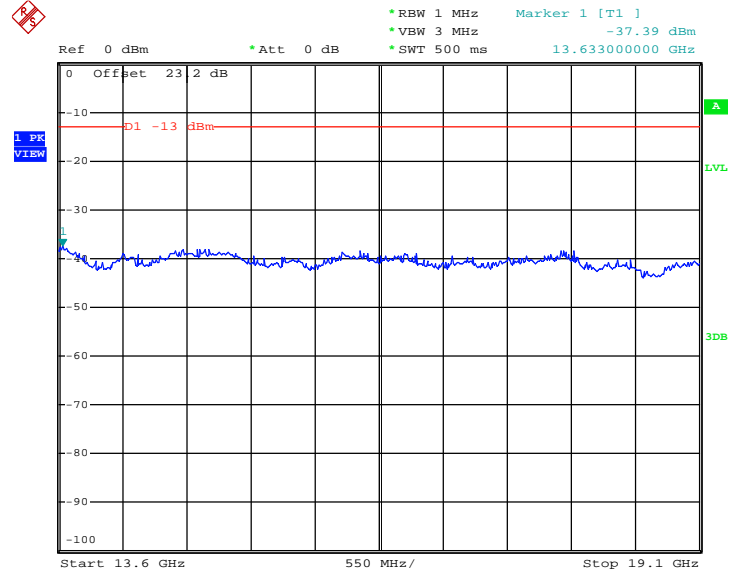

Date: 8.FEB.2014 10:42:53



Band :	GSM1900	Channel :	CH810
Test Mode :	GSM Link (GMSK)	Frequency :	1909.8 MHz

Conducted Spurious Emission Plot between 30MHz ~ 1GHz

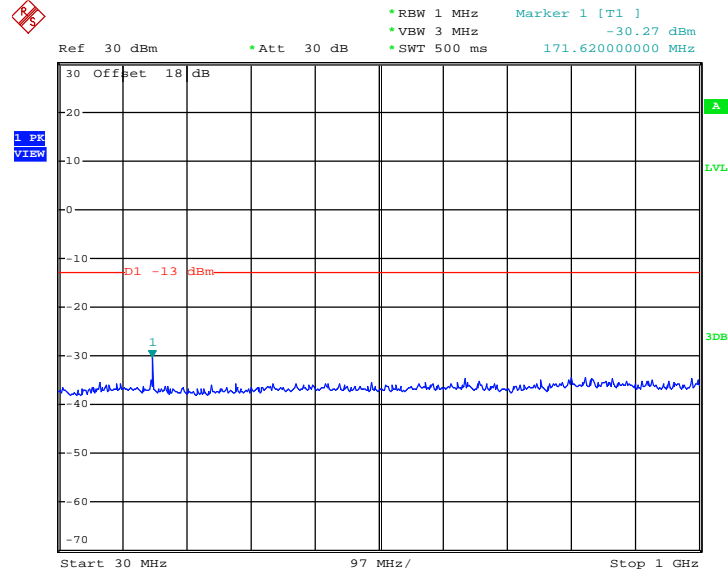

Date: 8.FEB.2014 11:01:20

Conducted Spurious Emission Plot between 1GHz ~ 3GHz

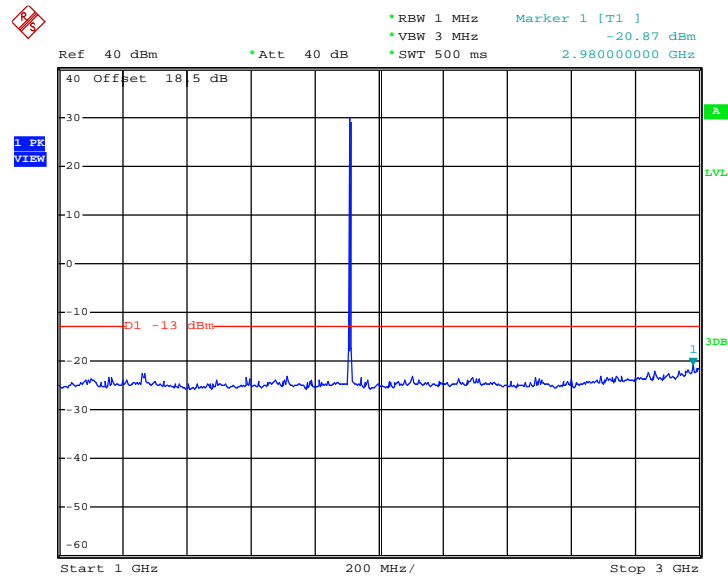

Date: 8.FEB.2014 10:56:26



### Conducted Spurious Emission Plot between 3GHz ~ 7GHz

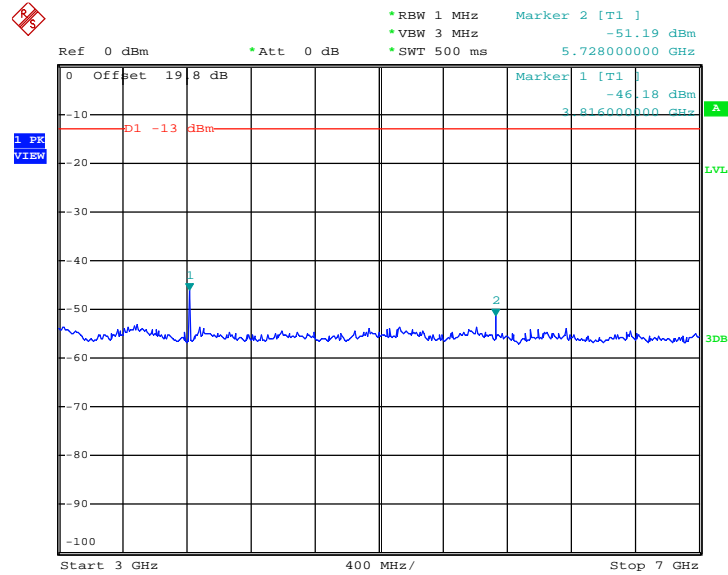

Date: 8.FEB.2014 10:51:04

### Conducted Emission Plot between 7GHz ~ 13.6GHz

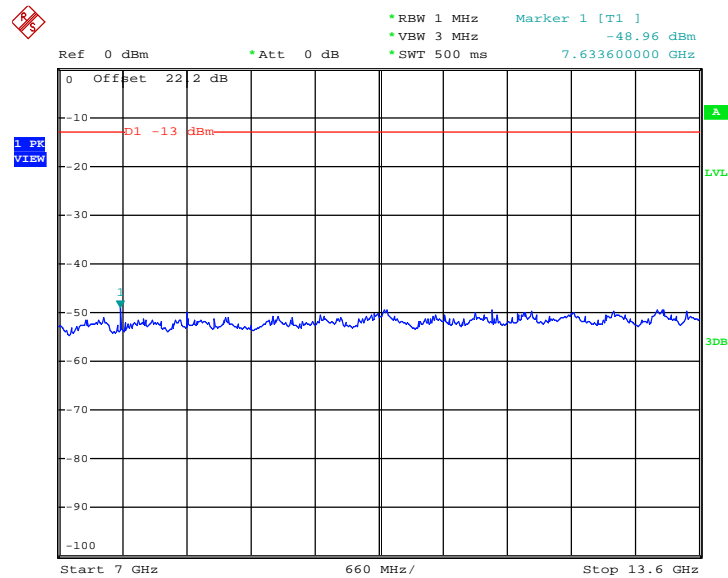

Date: 8.FEB.2014 10:44:32



Conducted Spurious Emission Plot between 13.6GHz ~ 19.1GHz

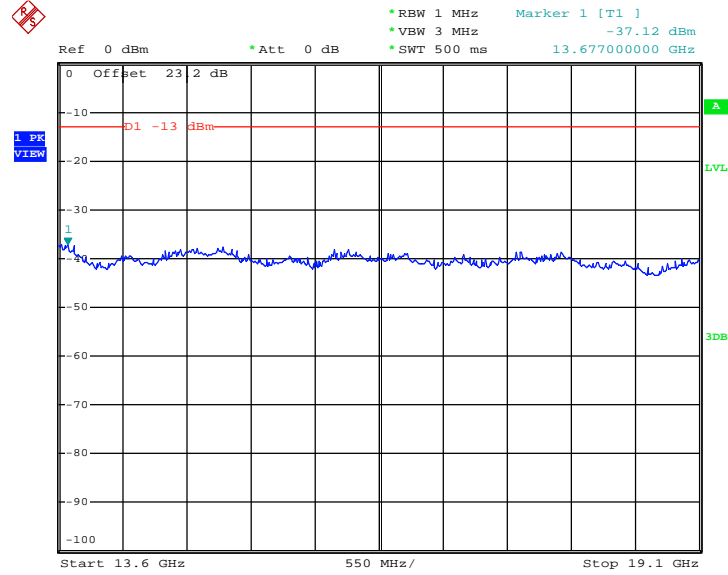

Date: 8.FEB.2014 10:43:32



Band :	GSM1900	Channel :	CH512
Test Mode :	EDGE class 8 Link (8PSK)	Frequency :	1850.2 MHz

Conducted Spurious Emission Plot between 30MHz ~ 1GHz

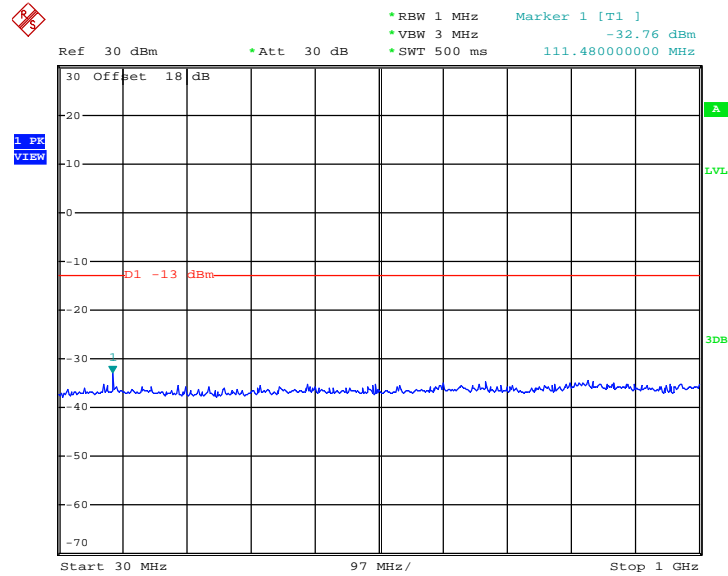

Date: 8.FEB.2014 10:20:32

Conducted Spurious Emission Plot between 1GHz ~ 3GHz

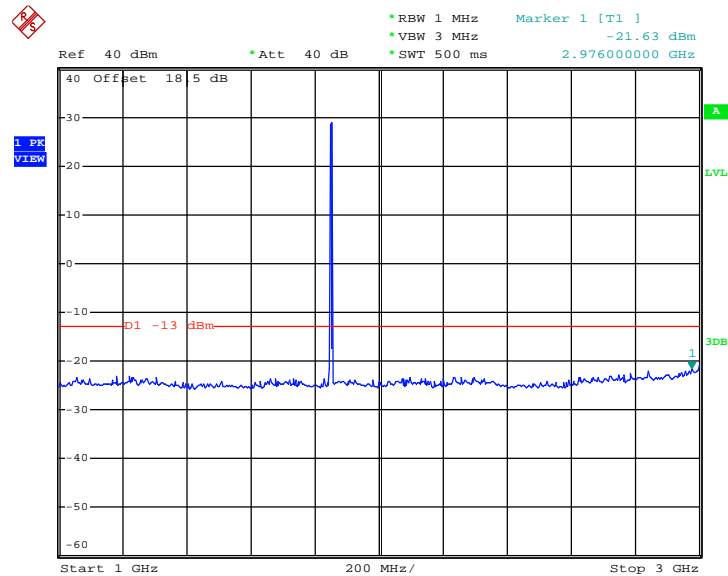

Date: 8.FEB.2014 10:22:23



### Conducted Spurious Emission Plot between 3GHz ~ 7GHz

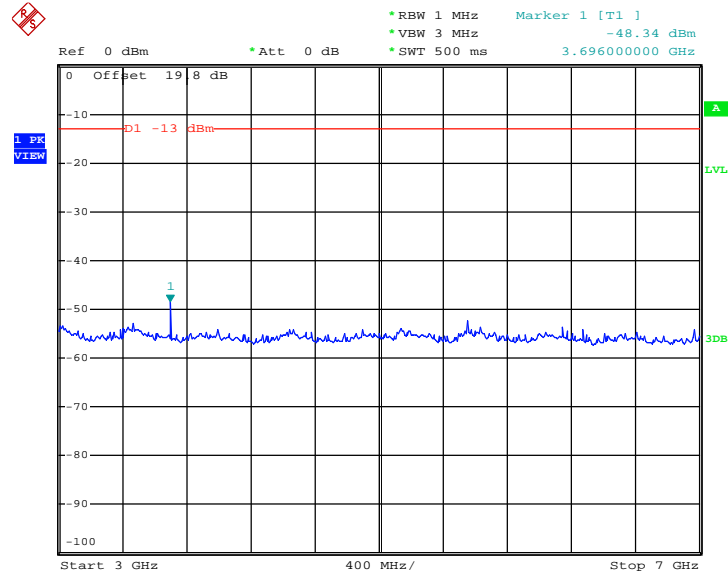

Date: 8.FEB.2014 10:30:15

### Conducted Spurious Emission Plot between 7GHz ~ 13.6GHz

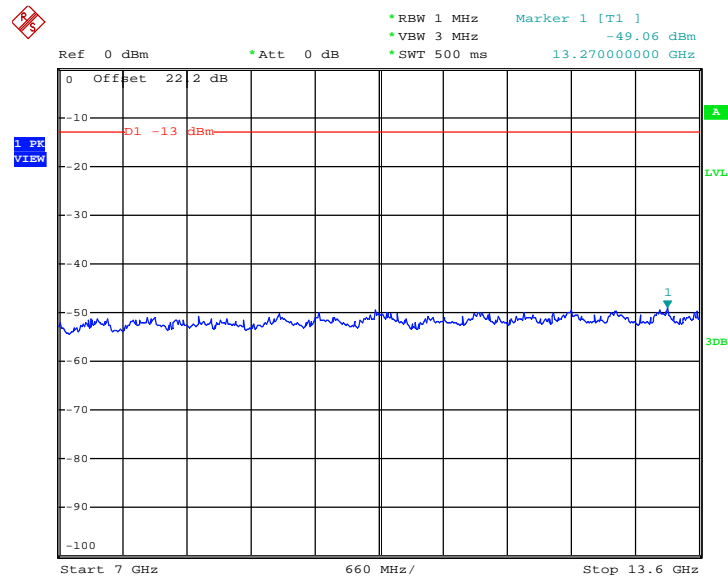

Date: 8.FEB.2014 10:31:16



Conducted Spurious Emission Plot between 13.6GHz ~ 19.1GHz

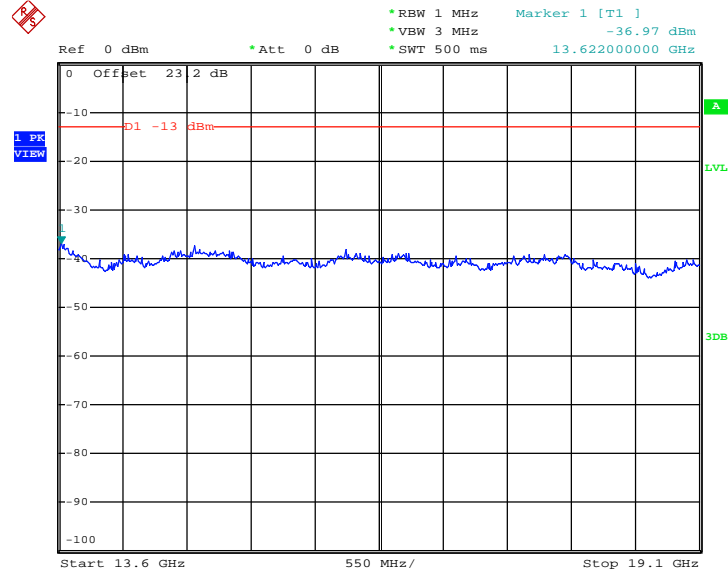

Date: 8.FEB.2014 10:34:38



Band :	GSM1900	Channel :	CH661
Test Mode :	EDGE class 8 Link (8PSK)	Frequency :	1880.0 MHz

Conducted Spurious Emission Plot between 30MHz ~ 1GHz

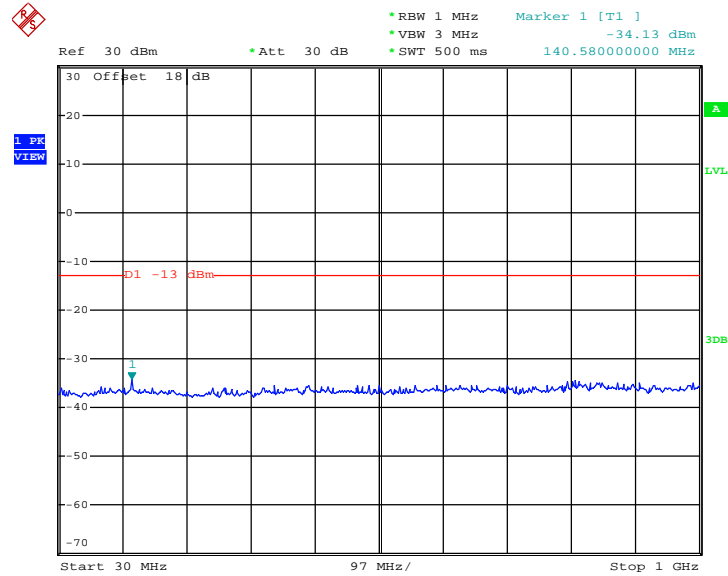

Date : 8.FEB.2014 10:19:55

Conducted Spurious Emission Plot between 1GHz ~ 3GHz

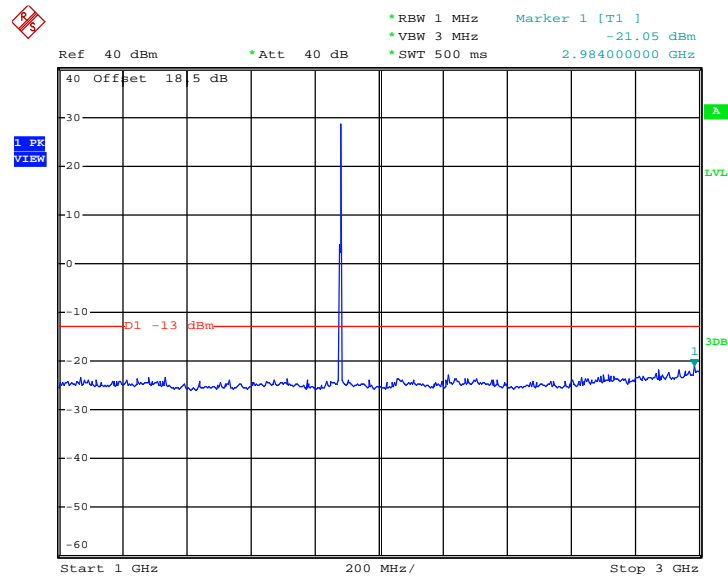

Date : 8.FEB.2014 10:23:10



### Conducted Spurious Emission Plot between 3GHz ~ 7GHz

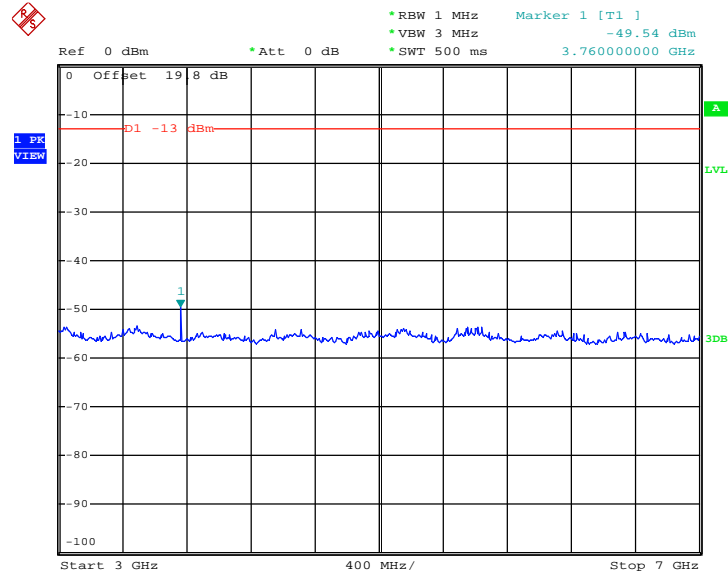

Date: 8.FEB.2014 10:28:47

### Conducted Spurious Emission Plot between 7GHz ~ 13.6GHz

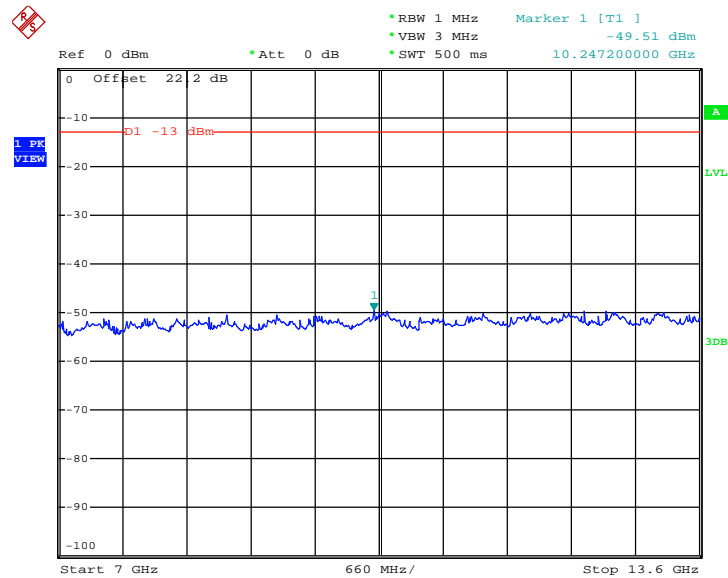

Date: 8.FEB.2014 10:31:47



Conducted Spurious Emission Plot between 13.6GHz ~ 19.1GHz

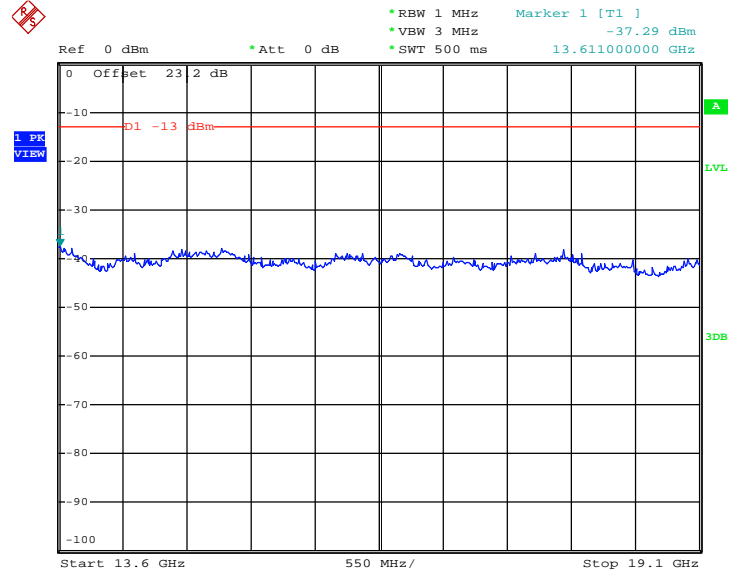

Date: 8.FEB.2014 10:34:10



Band :	GSM1900	Channel :	CH810
Test Mode :	EDGE class 8 Link (8PSK)	Frequency :	1909.8 MHz

Conducted Spurious Emission Plot between 30MHz ~ 1GHz

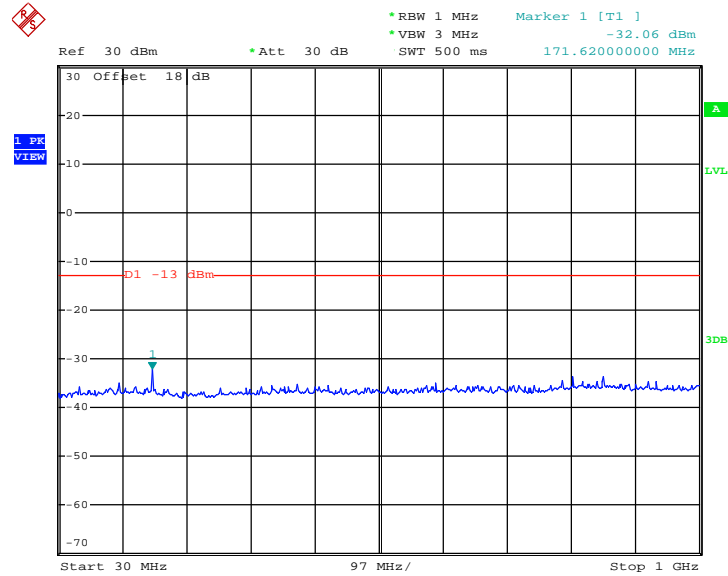

Date : 8.FEB.2014 10:19:21

Conducted Spurious Emission Plot between 1GHz ~ 3GHz

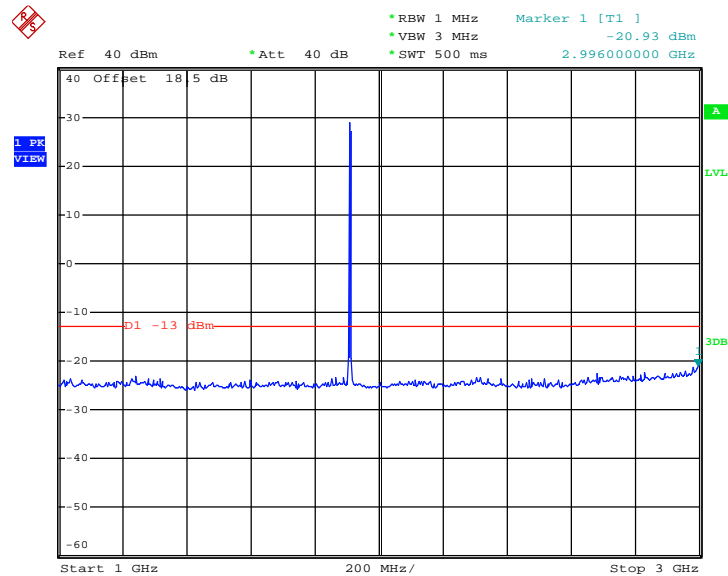

Date : 8.FEB.2014 10:25:14



### Conducted Spurious Emission Plot between 3GHz ~ 7GHz

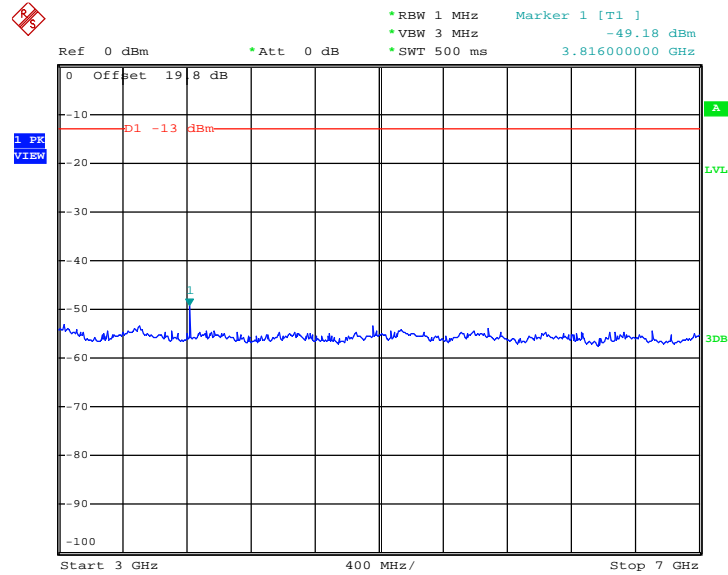

Date: 8.FEB.2014 10:28:06

### Conducted Spurious Emission Plot between 7GHz ~ 13.6GHz

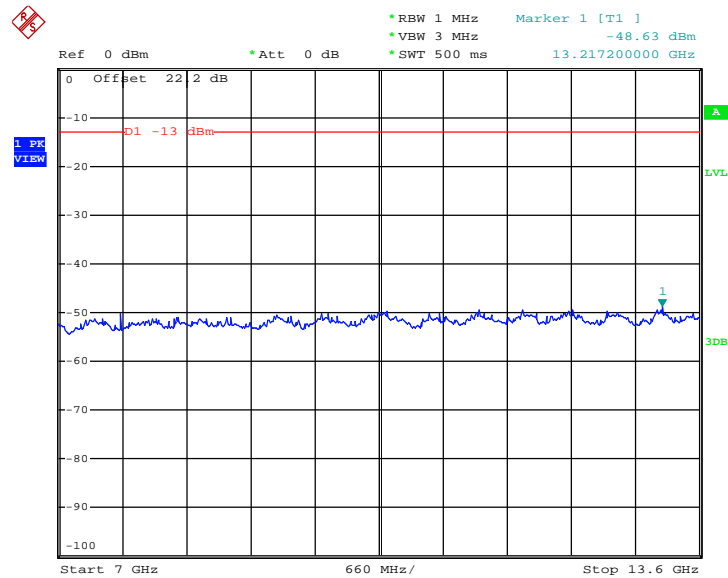

Date: 8.FEB.2014 10:32:40



Conducted Spurious Emission Plot between 13.6GHz ~ 19.1GHz

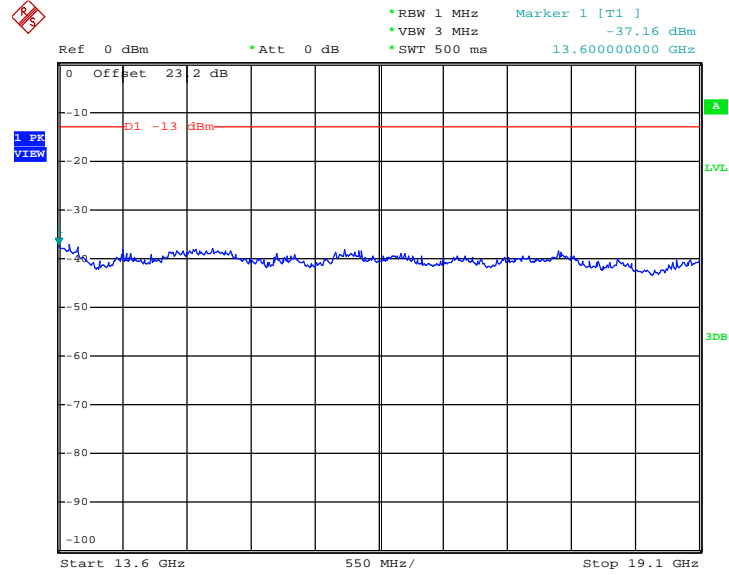

Date: 8.FEB.2014 10:35:36

## 3.7 Field Strength of Spurious Radiation Measurement

### 3.7.1 Description of Field Strength of Spurious Radiated Measurement

The power of any emission outside of the authorized operating frequency ranges must be attenuated below the transmitter power (P) by a factor of at least  $43 + 10 \log(P)$  dB. The spectrum is scanned from 30 MHz up to a frequency including its 10th harmonic.

### 3.7.2 Measuring Instruments

The measuring equipment is listed in the section 4 of this test report.

### 3.7.3 Test Procedures

1. The EUT was placed on a rotatable wooden table with 0.8 meter above ground.
2. The EUT was set 3 meters from the receiving antenna, which was mounted on the antenna tower.
3. The table was rotated 360 degrees to determine the position of the highest spurious emission.
4. The height of the receiving antenna is varied between one meter and four meters to search the maximum spurious emission for both horizontal and vertical polarizations.
5. Make the measurement with the spectrum analyzer's RBW = 1MHz, VBW = 3MHz, taking the record of maximum spurious emission.
6. A horn antenna was substituted in place of the EUT and was driven by a signal generator.
7. Tune the output power of signal generator to the same emission level with EUT maximum spurious emission.
8. Taking the record of output power at antenna port.
9. Repeat step 7 to step 8 for another polarization.
10. The RF fundamental frequency should be excluded against the limit line in the operating frequency band.
11. The limit line is derived from  $43 + 10\log(P)$  dB below the transmitter power P(Watts)  
 $= P(W) - [43 + 10\log(P)]$  (dB)  
 $= [30 + 10\log(P)]$  (dBm) -  $[43 + 10\log(P)]$  (dB)  
 $= -13\text{dBm}$ .
12. EIRP (dBm) = S.G. Power – Tx Cable Loss + Tx Antenna Gain
13. ERP (dBm) = EIRP - 2.15

### 3.7.4 Test Setup

For radiated emissions from 30MHz to 1GHz

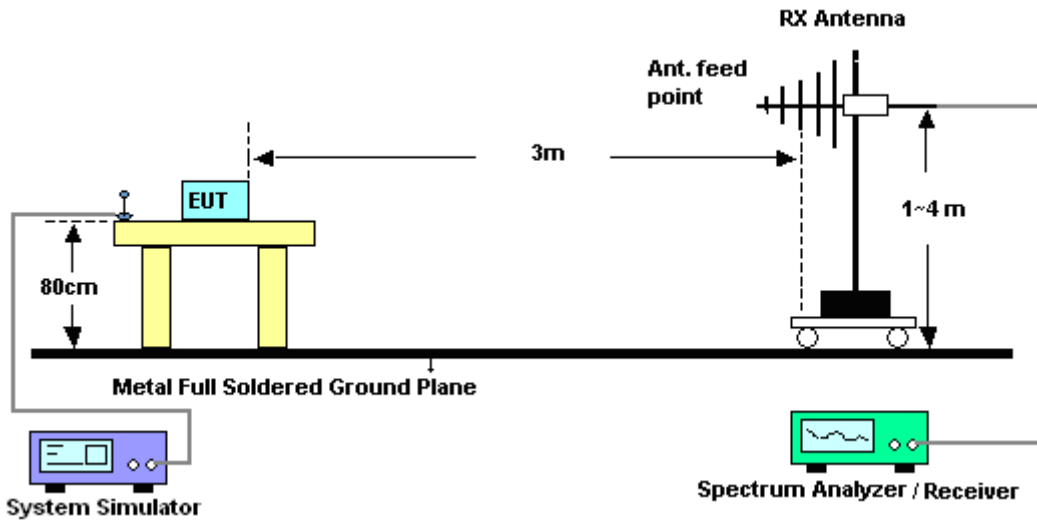

For radiated emissions above 1GHz

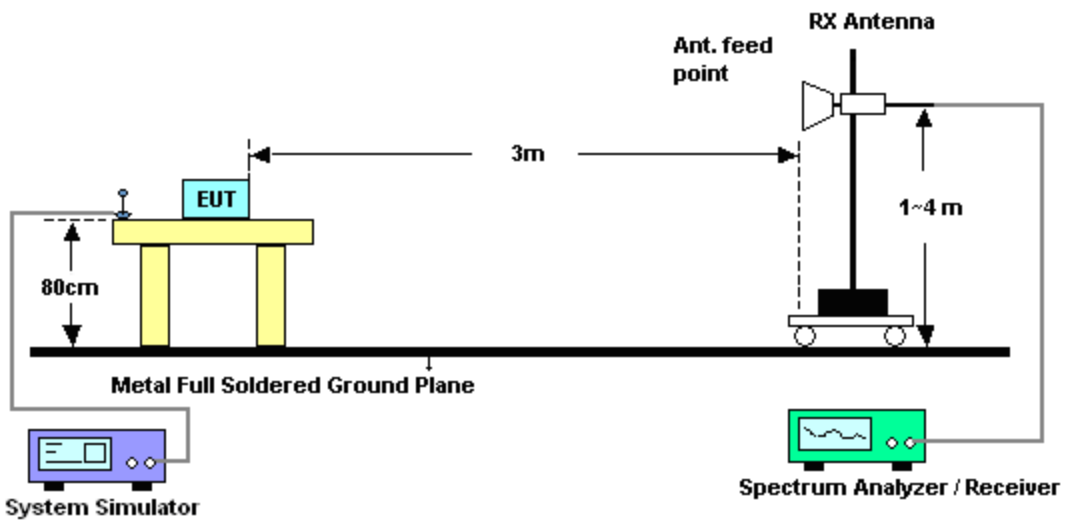



### 3.7.5 Test Result of Field Strength of Spurious Radiated

SIM1 Card:

Band :	GSM850 for CH 128	Temperature :	23~24°C
Test Mode :	GSM Link (GMSK)	Relative Humidity :	46~49%
Test Engineer :	Robin Luo	Polarization :	Horizontal
Remark :	Spurious emissions within 30-1000MHz were found more than 20dB below limit line.		

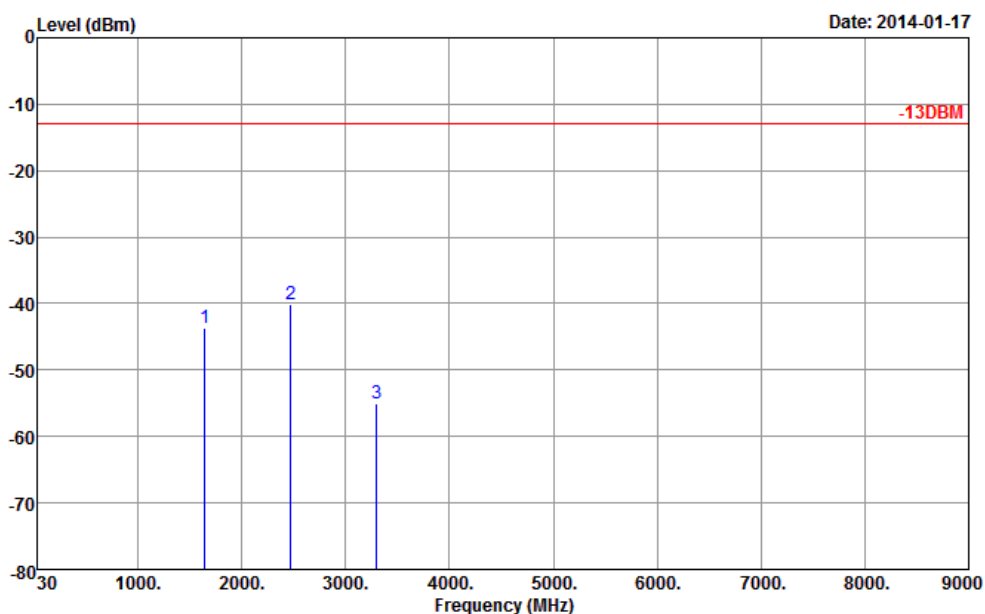

Site : 03CH01-SZ  
 Condition : -13DBM HF\_EIRP\_H\_130101 HORIZONTAL  
 Project : (FG)410803

Frequency ( MHz )	ERP ( dBm )	Limit ( dBm )	Over Limit ( dB )	SPA Reading ( dBm )	S.G. Power ( dBm )	TX Cable loss ( dB )	TX Antenna Gain ( dBi )	Polarization ( H/V )	Result
1648.4	-43.68	-13	-30.68	-60.30	-46.50	0.73	5.70	H	Pass
2472.6	-40.06	-13	-27.06	-64.69	-42.42	0.91	5.42	H	Pass
3296.8	-54.96	-13	-41.96	-65.83	-59.60	1.07	7.86	H	Pass



<b>Band :</b>	GSM850 for CH 128	<b>Temperature :</b>	23~24°C
<b>Test Mode :</b>	GSM Link (GMSK)	<b>Relative Humidity :</b>	46~49%
<b>Test Engineer :</b>	Robin Luo	<b>Polarization :</b>	Vertical
<b>Remark :</b>	Spurious emissions within 30-1000MHz were found more than 20dB below limit line.		

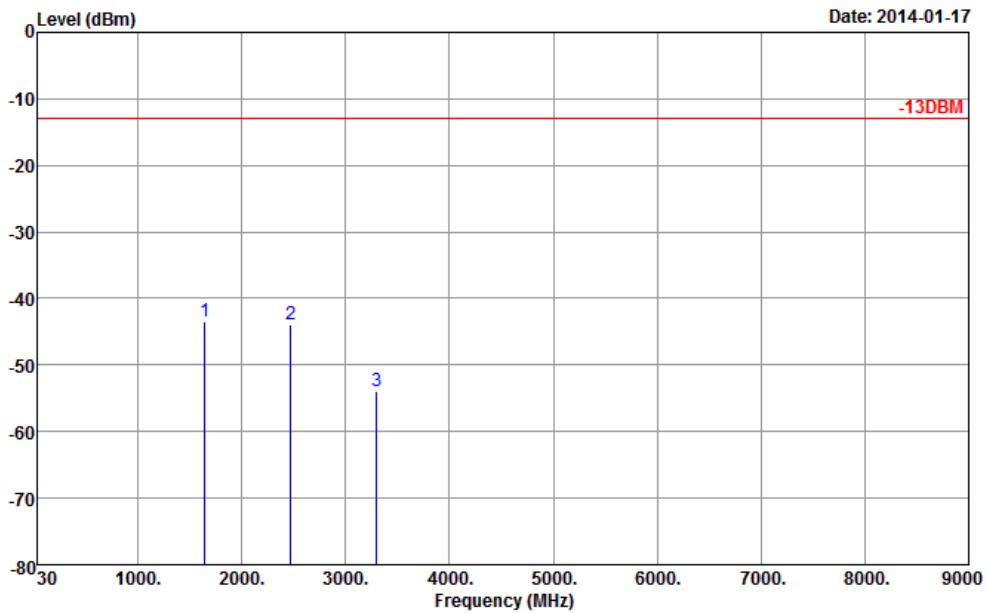

Site : 03CH01-SZ  
 Condition : -13DBM HF\_EIRP\_V\_130101 VERTICAL  
 Project : (FG)410803

Frequency ( MHz )	ERP ( dBm )	Limit ( dBm )	Over Limit ( dB )	SPA Reading ( dBm )	S.G. Power ( dBm )	TX Cable loss ( dB )	TX Antenna Gain ( dBi )	Polarization ( H/V )	Result
1648.4	-43.56	-13	-30.56	-57.43	-46.38	0.73	5.70	V	Pass
2472.6	-43.84	-13	-30.84	-65.55	-46.20	0.91	5.42	V	Pass
3296.8	-53.98	-13	-40.98	-66.16	-58.62	1.07	7.86	V	Pass



<b>Band :</b>	GSM850 for CH 189	<b>Temperature :</b>	23~24°C
<b>Test Mode :</b>	GSM Link (GMSK)	<b>Relative Humidity :</b>	46~49%
<b>Test Engineer :</b>	Robin Luo	<b>Polarization :</b>	Horizontal
<b>Remark :</b>	Spurious emissions within 30-1000MHz were found more than 20dB below limit line.		

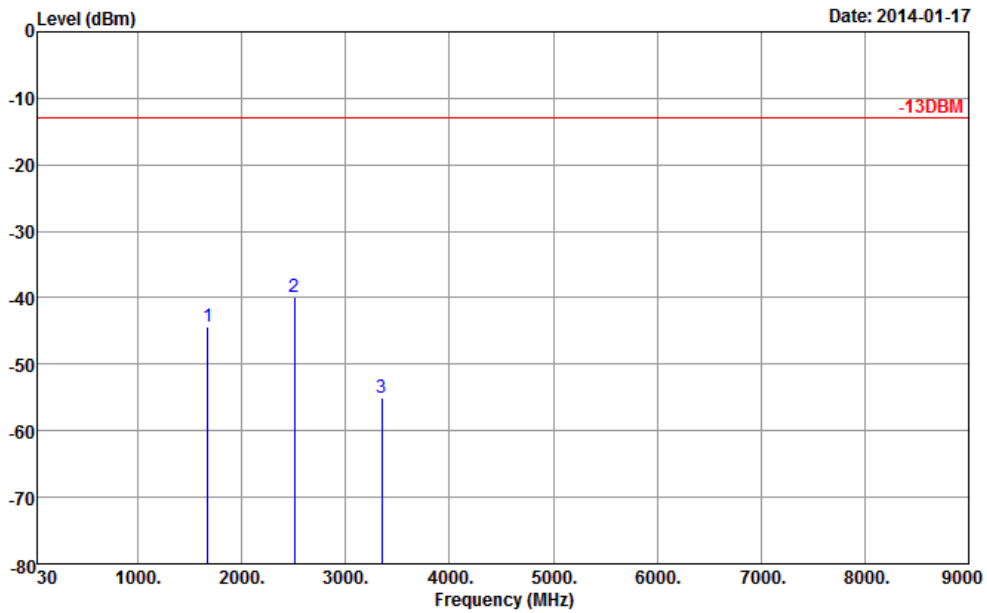

Site : 03CH01-SZ  
 Condition : -13DBM HF\_EIRP\_H\_130101 HORIZONTAL  
 Project : (FG)410803

Frequency ( MHz )	ERP ( dBm )	Limit ( dBm )	Over Limit ( dB )	SPA Reading ( dBm )	S.G. Power ( dBm )	TX Cable loss ( dB )	TX Antenna Gain ( dBi )	Polarization ( H/V )	Result
1672	-44.38	-13	-31.38	-60.37	-47.35	0.88	6.00	H	Pass
2510	-39.90	-13	-26.90	-64.24	-42.51	1.08	5.84	H	Pass
3346	-55.02	-13	-42.02	-65.62	-59.39	1.14	7.66	H	Pass



<b>Band :</b>	GSM850 for CH 189	<b>Temperature :</b>	23~24°C
<b>Test Mode :</b>	GSM Link (GMSK)	<b>Relative Humidity :</b>	46~49%
<b>Test Engineer :</b>	Robin Luo	<b>Polarization :</b>	Vertical
<b>Remark :</b>	Spurious emissions within 30-1000MHz were found more than 20dB below limit line.		

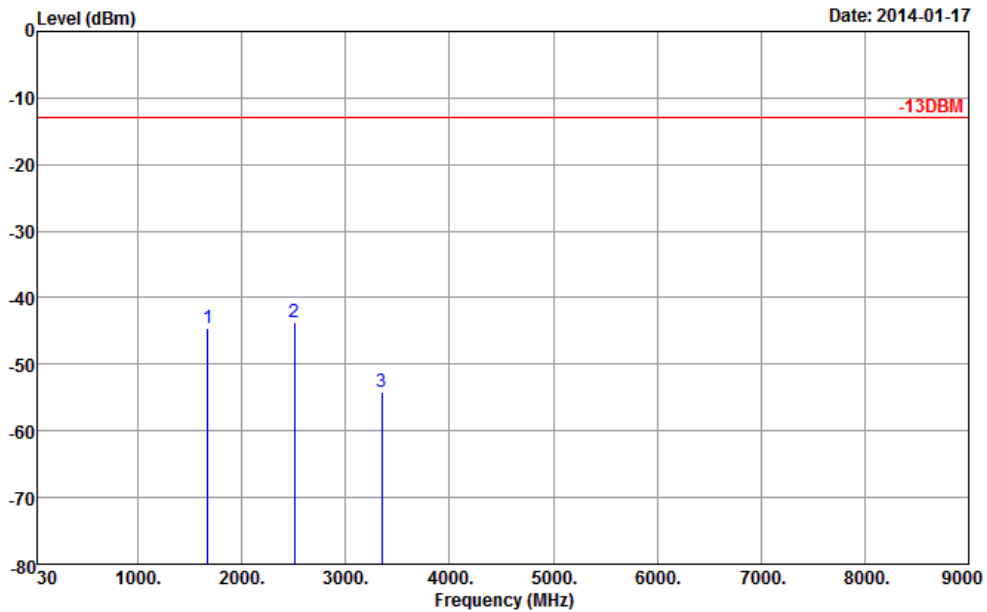

Site : 03CH01-SZ  
 Condition : -13DBM HF\_EIRP\_V\_130101 VERTICAL  
 Project : (FG)410803

Frequency ( MHz )	ERP ( dBm )	Limit ( dBm )	Over Limit ( dB )	SPA Reading ( dBm )	S.G. Power ( dBm )	TX Cable loss ( dB )	TX Antenna Gain ( dBi )	Polarization ( H/V )	Result
1672	-44.57	-13	-31.57	-58.02	-47.54	0.88	6.00	V	Pass
2510	-43.68	-13	-30.68	-65.10	-46.29	1.08	5.84	V	Pass
3346	-54.23	-13	-41.23	-66.06	-58.60	1.14	7.66	V	Pass



<b>Band :</b>	GSM850 for CH 251	<b>Temperature :</b>	23~24°C
<b>Test Mode :</b>	GSM Link (GMSK)	<b>Relative Humidity :</b>	46~49%
<b>Test Engineer :</b>	Robin Luo	<b>Polarization :</b>	Horizontal
<b>Remark :</b>	Spurious emissions within 30-1000MHz were found more than 20dB below limit line.		

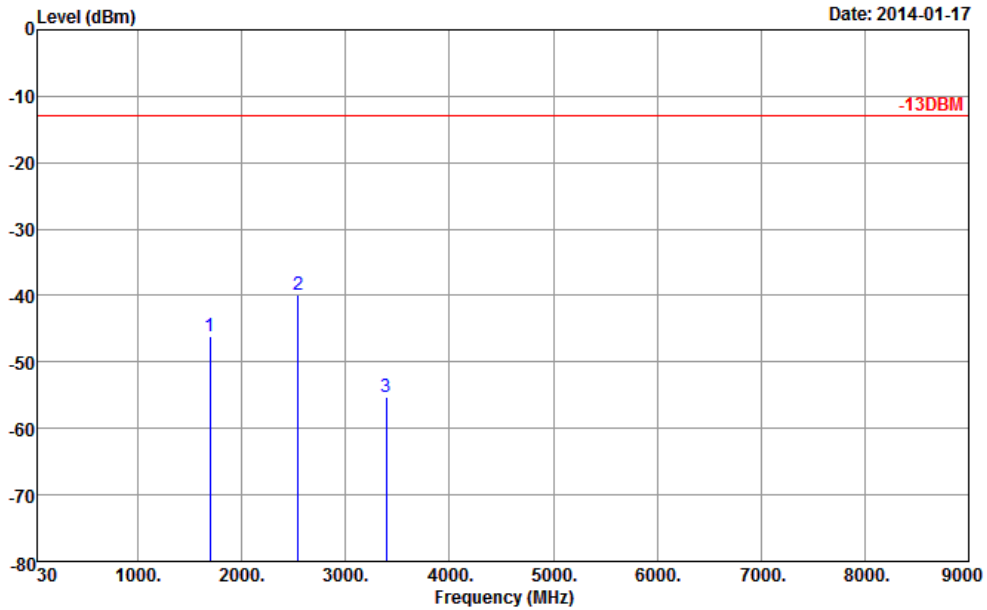

Site : 03CH01-SZ  
 Condition : -13DBM HF\_EIRP\_H\_130101 HORIZONTAL  
 Project : (FG)410803

Frequency ( MHz )	ERP ( dBm )	Limit ( dBm )	Over Limit ( dB )	SPA Reading ( dBm )	S.G. Power ( dBm )	TX Cable loss ( dB )	TX Antenna Gain ( dBi )	Polarization ( H/V )	Result
1697.6	-46.06	-13	-33.06	-62.11	-48.85	0.95	5.89	H	Pass
2546.4	-39.87	-13	-26.87	-64.60	-42.58	1.12	5.98	H	Pass
3395.2	-55.30	-13	-42.30	-66.50	-59.70	1.25	7.80	H	Pass



<b>Band :</b>	GSM850 for CH 251	<b>Temperature :</b>	23~24°C
<b>Test Mode :</b>	GSM Link (GMSK)	<b>Relative Humidity :</b>	46~49%
<b>Test Engineer :</b>	Robin Luo	<b>Polarization :</b>	Vertical
<b>Remark :</b>	Spurious emissions within 30-1000MHz were found more than 20dB below limit line.		

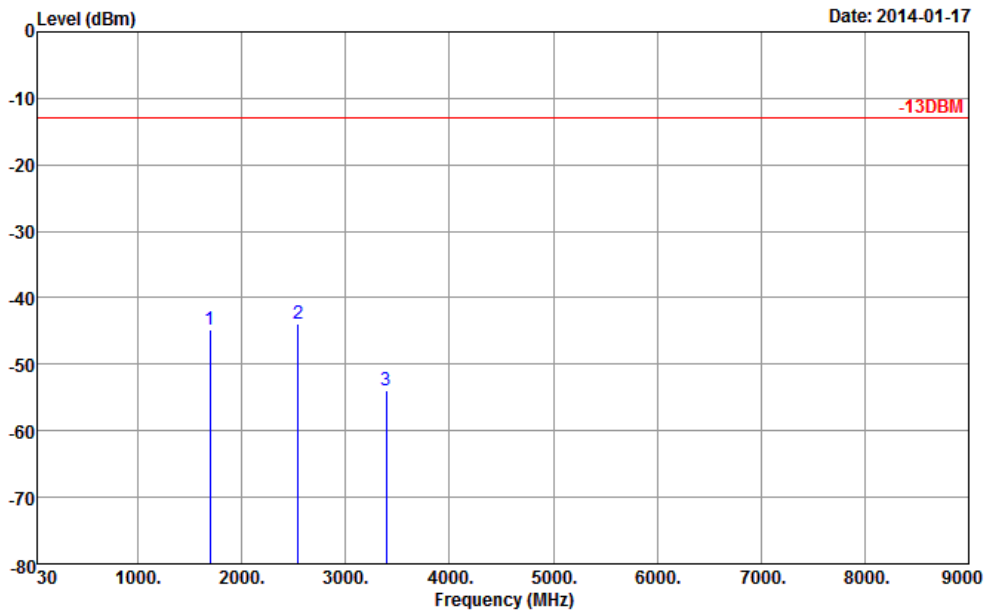

Site : 03CH01-SZ  
 Condition : -13DBM HF\_EIRP\_V\_130101 VERTICAL  
 Project : (FG)410803

Frequency ( MHz )	ERP ( dBm )	Limit ( dBm )	Over Limit ( dB )	SPA Reading ( dBm )	S.G. Power ( dBm )	TX Cable loss ( dB )	TX Antenna Gain ( dBi )	Polarization ( H/V )	Result
1697.6	-44.80	-13	-31.80	-58.65	-47.59	0.95	5.89	V	Pass
2546.4	-43.91	-13	-30.91	-65.71	-46.62	1.12	5.98	V	Pass
3395.2	-54.03	-13	-41.03	-66.46	-58.43	1.25	7.80	V	Pass



<b>Band :</b>	GSM850 for CH 128	<b>Temperature :</b>	23~24°C
<b>Test Mode :</b>	EDGE class 8 Link (8PSK)	<b>Relative Humidity :</b>	46~49%
<b>Test Engineer :</b>	Robin Luo	<b>Polarization :</b>	Horizontal
<b>Remark :</b>	Spurious emissions within 30-1000MHz were found more than 20dB below limit line.		

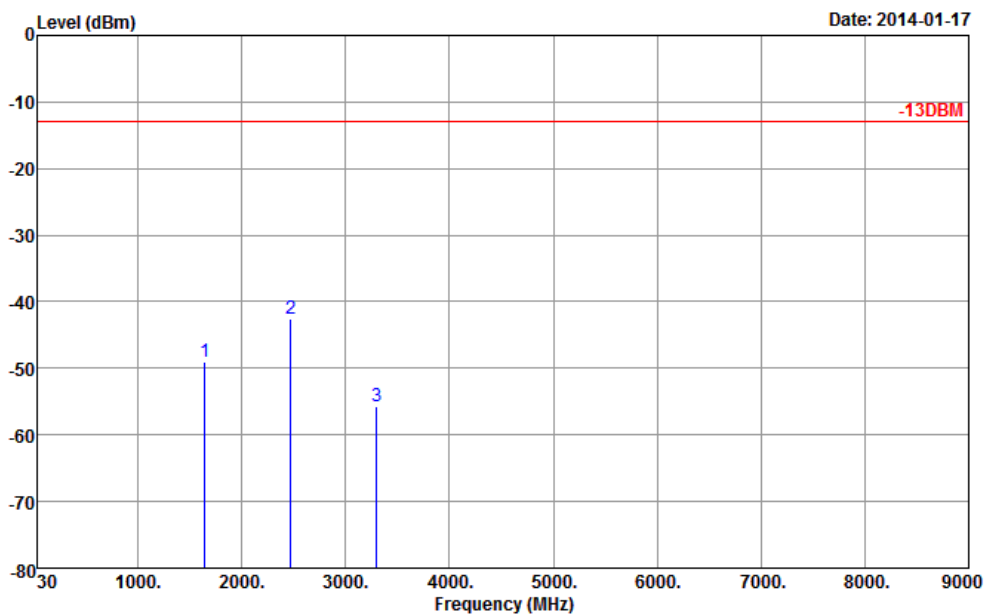

Site : 03CH01-SZ  
 Condition : -13DBM HF\_EIRP\_H\_130101 HORIZONTAL  
 Project : (FG)410803

Frequency ( MHz )	ERP ( dBm )	Limit ( dBm )	Over Limit ( dB )	SPA Reading ( dBm )	S.G. Power ( dBm )	TX Cable loss ( dB )	TX Antenna Gain ( dBi )	Polarization ( H/V )	Result
1648.4	-49.04	-13	-36.04	-64.35	-51.86	0.73	5.70	H	Pass
2472.6	-42.62	-13	-29.62	-66.63	-44.98	0.91	5.42	H	Pass
3296.8	-55.75	-13	-42.75	-66.62	-60.39	1.07	7.86	H	Pass



<b>Band :</b>	GSM850 for CH 128	<b>Temperature :</b>	23~24°C
<b>Test Mode :</b>	EDGE class 8 Link (8PSK)	<b>Relative Humidity :</b>	46~49%
<b>Test Engineer :</b>	Robin Luo	<b>Polarization :</b>	Vertical
<b>Remark :</b>	Spurious emissions within 30-1000MHz were found more than 20dB below limit line.		

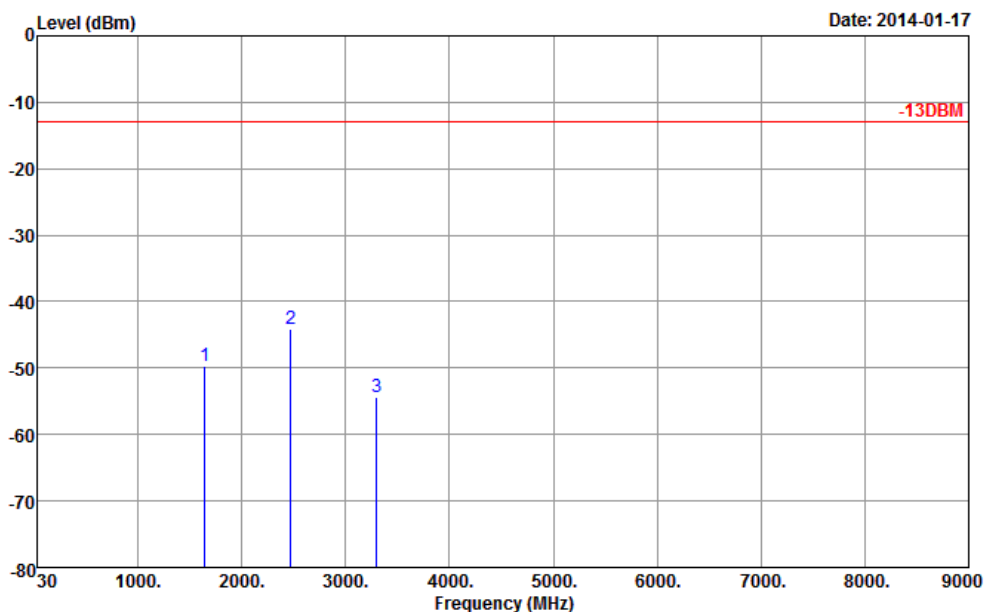

Site : 03CH01-SZ  
 Condition : -13DBM HF\_EIRP\_V\_130101 VERTICAL  
 Project : (FG)410803

Frequency ( MHz )	ERP ( dBm )	Limit ( dBm )	Over Limit ( dB )	SPA Reading ( dBm )	S.G. Power ( dBm )	TX Cable loss ( dB )	TX Antenna Gain ( dBi )	Polarization ( H/V )	Result
1648.4	-49.75	-13	-36.75	-62.79	-52.57	0.73	5.70	V	Pass
2472.6	-44.09	-13	-31.09	-65.79	-46.45	0.91	5.42	V	Pass
3296.8	-54.30	-13	-41.30	-66.48	-58.94	1.07	7.86	V	Pass



<b>Band :</b>	GSM850 for CH 189	<b>Temperature :</b>	23~24°C
<b>Test Mode :</b>	EDGE class 8 Link (8PSK)	<b>Relative Humidity :</b>	46~49%
<b>Test Engineer :</b>	Robin Luo	<b>Polarization :</b>	Horizontal
<b>Remark :</b>	Spurious emissions within 30-1000MHz were found more than 20dB below limit line.		

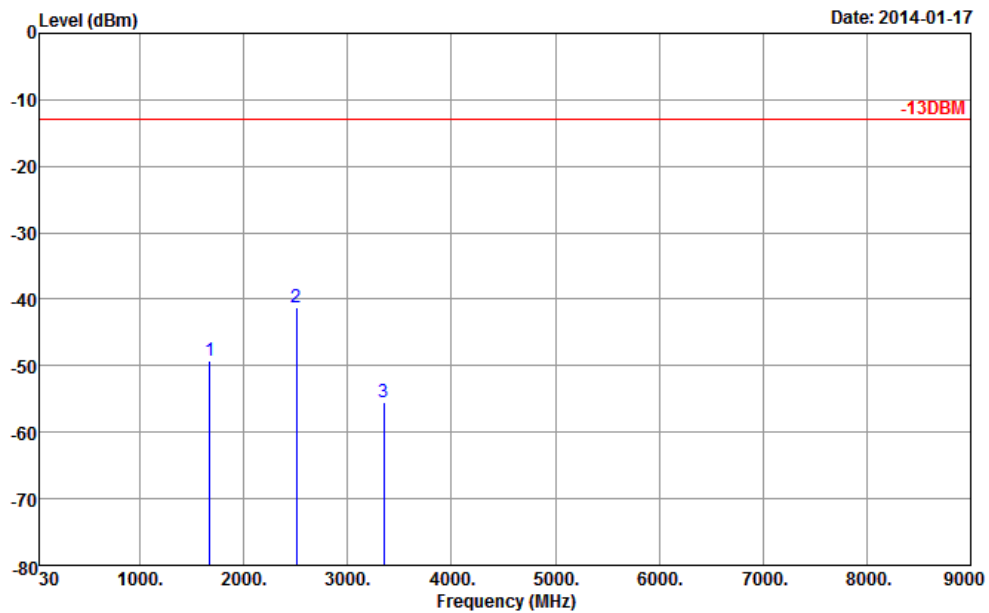

Site : 03CH01-SZ  
 Condition : -13DBM HF\_EIRP\_H\_130101 HORIZONTAL  
 Project : (FG)410803

Frequency ( MHz )	ERP ( dBm )	Limit ( dBm )	Over Limit ( dB )	SPA Reading ( dBm )	S.G. Power ( dBm )	TX Cable loss ( dB )	TX Antenna Gain ( dBi )	Polarization ( H/V )	Result
1672	-49.15	-13	-36.15	-63.93	-52.12	0.88	6.00	H	Pass
2510	-41.32	-13	-28.32	-65.36	-43.93	1.08	5.84	H	Pass
3346	-55.58	-13	-42.58	-66.18	-59.95	1.14	7.66	H	Pass



<b>Band :</b>	GSM850 for CH 189	<b>Temperature :</b>	23~24°C
<b>Test Mode :</b>	EDGE class 8 Link (8PSK)	<b>Relative Humidity :</b>	46~49%
<b>Test Engineer :</b>	Robin Luo	<b>Polarization :</b>	Vertical
<b>Remark :</b>	Spurious emissions within 30-1000MHz were found more than 20dB below limit line.		

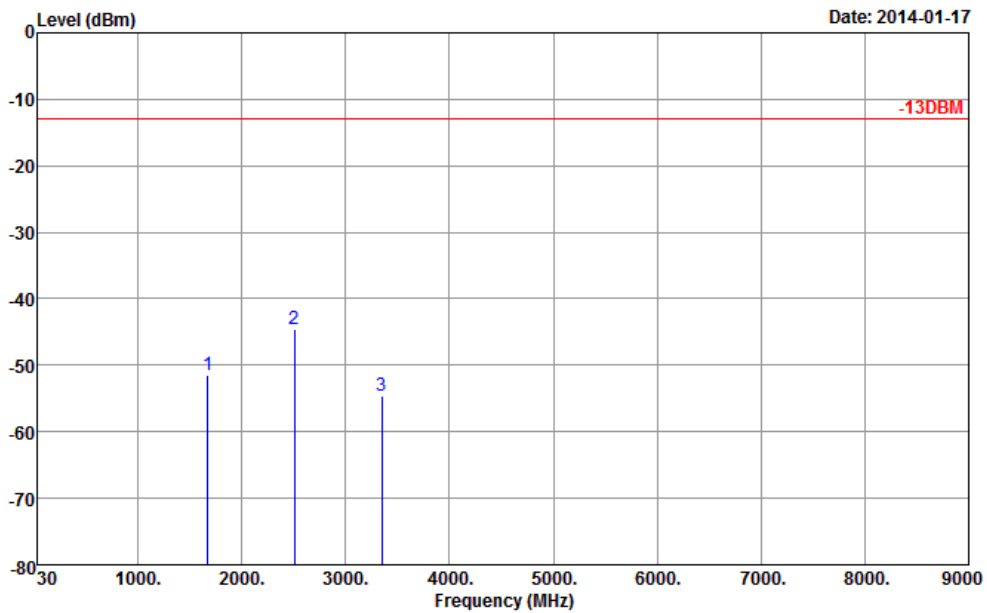

Site : 03CH01-SZ  
 Condition : -13DBM HF\_EIRP\_V\_130101 VERTICAL  
 Project : (FG)410803

Frequency ( MHz )	ERP ( dBm )	Limit ( dBm )	Over Limit ( dB )	SPA Reading ( dBm )	S.G. Power ( dBm )	TX Cable loss ( dB )	TX Antenna Gain ( dBi )	Polarization ( H/V )	Result
1672	-51.44	-13	-38.44	-63.58	-54.41	0.88	6.00	V	Pass
2510	-44.46	-13	-31.46	-65.86	-47.07	1.08	5.84	V	Pass
3346	-54.49	-13	-41.49	-66.32	-58.86	1.14	7.66	V	Pass



<b>Band :</b>	GSM850 for CH 251	<b>Temperature :</b>	23~24°C
<b>Test Mode :</b>	EDGE class 8 Link (8PSK)	<b>Relative Humidity :</b>	46~49%
<b>Test Engineer :</b>	Robin Luo	<b>Polarization :</b>	Horizontal
<b>Remark :</b>	Spurious emissions within 30-1000MHz were found more than 20dB below limit line.		

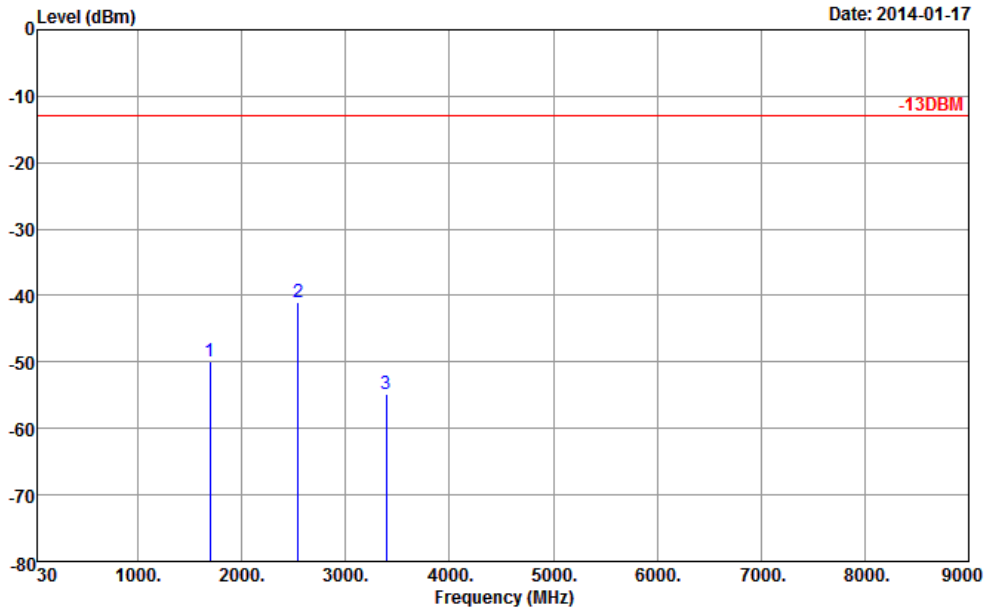

Site : 03CH01-SZ  
 Condition : -13DBM HF\_EIRP\_H\_130101 HORIZONTAL  
 Project : (FG)410803

Frequency ( MHz )	ERP ( dBm )	Limit ( dBm )	Over Limit ( dB )	SPA Reading ( dBm )	S.G. Power ( dBm )	TX Cable loss ( dB )	TX Antenna Gain ( dBi )	Polarization ( H/V )	Result
1697.6	-49.94	-13	-36.94	-64.99	-52.73	0.95	5.89	H	Pass
2546.4	-41.05	-13	-28.05	-65.54	-43.76	1.12	5.98	H	Pass
3395.2	-54.74	-13	-41.74	-65.94	-59.14	1.25	7.80	H	Pass



<b>Band :</b>	GSM850 for CH 251	<b>Temperature :</b>	23~24°C
<b>Test Mode :</b>	EDGE class 8 Link (8PSK)	<b>Relative Humidity :</b>	46~49%
<b>Test Engineer :</b>	Robin Luo	<b>Polarization :</b>	Vertical
<b>Remark :</b>	Spurious emissions within 30-1000MHz were found more than 20dB below limit line.		

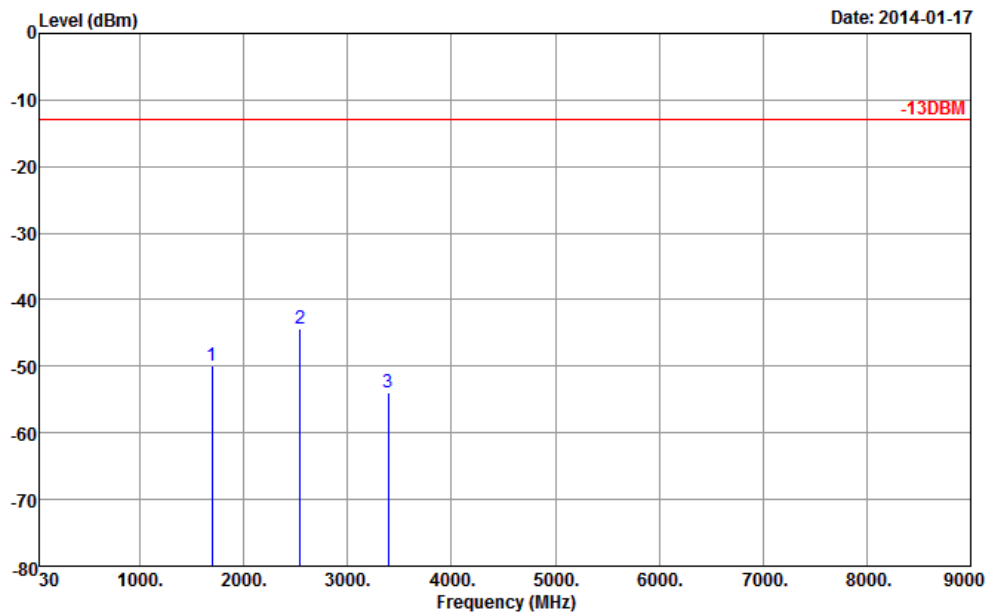

Site : 03CH01-SZ  
 Condition : -13DBM HF\_EIRP\_V\_130101 VERTICAL  
 Project : (FG)410803

Frequency ( MHz )	ERP ( dBm )	Limit ( dBm )	Over Limit ( dB )	SPA Reading ( dBm )	S.G. Power ( dBm )	TX Cable loss ( dB )	TX Antenna Gain ( dBi )	Polarization ( H/V )	Result
1697.6	-49.83	-13	-36.83	-62.66	-52.62	0.95	5.89	V	Pass
2546.4	-44.37	-13	-31.37	-66.16	-47.08	1.12	5.98	V	Pass
3395.2	-53.86	-13	-40.86	-66.29	-58.26	1.25	7.80	V	Pass



<b>Band :</b>	GSM1900 for CH 512	<b>Temperature :</b>	23~24°C
<b>Test Mode :</b>	GSM Link (GMSK)	<b>Relative Humidity :</b>	46~49%
<b>Test Engineer :</b>	Robin Luo	<b>Polarization :</b>	Horizontal
<b>Remark :</b>	Spurious emissions within 30-1000MHz were found more than 20dB below limit line.		

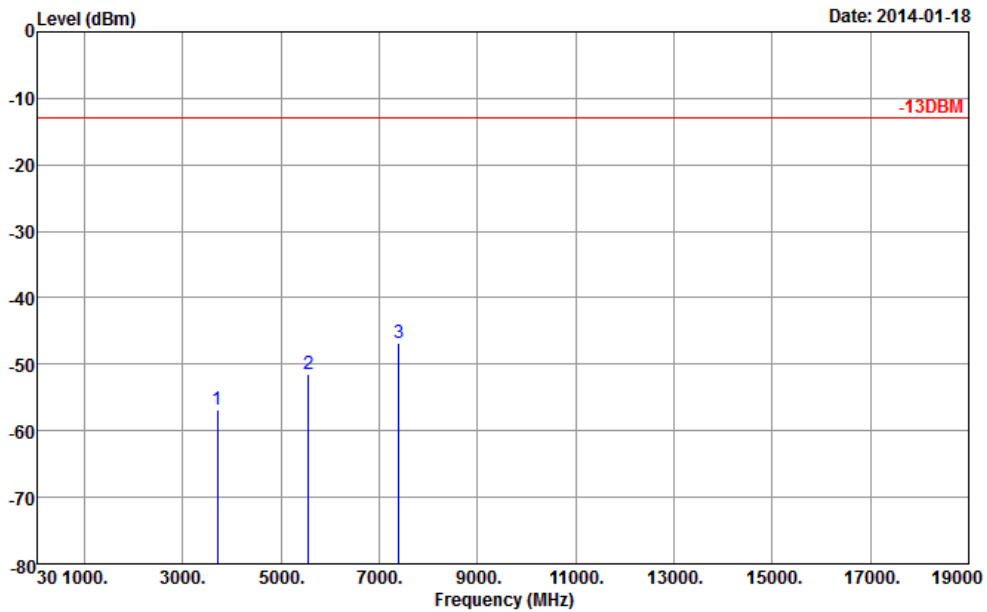

Site : 03CH01-SZ  
 Condition : -13DBM HF\_EIRP\_H\_130101 HORIZONTAL  
 Project : (FG)410803

Frequency ( MHz )	EIRP ( dBm )	Limit ( dBm )	Over Limit ( dB )	SPA Reading ( dBm )	S.G. Power ( dBm )	TX Cable loss ( dB )	TX Antenna Gain ( dBi )	Polarization ( H/V )	Result
3700.4	-56.85	-13	-43.85	-68.40	-63.60	1.2	7.95	H	Pass
5550.6	-51.57	-13	-38.57	-68.96	-59.67	1.5	9.60	H	Pass
7400.8	-46.90	-13	-33.90	-68.48	-57.09	1.7	11.89	H	Pass



<b>Band :</b>	GSM1900 for CH 512	<b>Temperature :</b>	23~24°C
<b>Test Mode :</b>	GSM Link (GMSK)	<b>Relative Humidity :</b>	46~49%
<b>Test Engineer :</b>	Robin Luo	<b>Polarization :</b>	Vertical
<b>Remark :</b>	Spurious emissions within 30-1000MHz were found more than 20dB below limit line.		

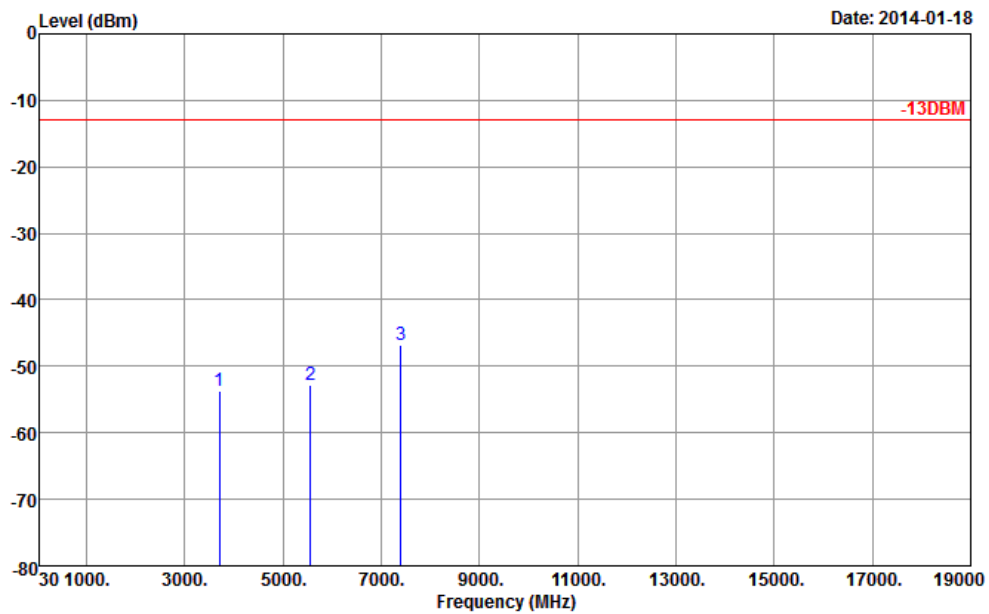

Site : 03CH01-SZ  
 Condition : -13DBM HF\_EIRP\_V\_130101 VERTICAL  
 Project : (FG)410803

Frequency ( MHz )	EIRP ( dBm )	Limit ( dBm )	Over Limit ( dB )	SPA Reading ( dBm )	S.G. Power ( dBm )	TX Cable loss ( dB )	TX Antenna Gain ( dBi )	Polarization ( H/V )	Result
3700.4	-53.79	-13	-40.79	-68.22	-60.54	1.2	7.95	V	Pass
5550.6	-52.83	-13	-39.83	-69.31	-60.93	1.5	9.6	V	Pass
7400.8	-46.70	-13	-33.70	-68.59	-56.89	1.7	11.89	V	Pass



<b>Band :</b>	GSM1900 for CH 661	<b>Temperature :</b>	23~24°C
<b>Test Mode :</b>	GSM Link (GMSK)	<b>Relative Humidity :</b>	46~49%
<b>Test Engineer :</b>	Robin Luo	<b>Polarization :</b>	Horizontal
<b>Remark :</b>	Spurious emissions within 30-1000MHz were found more than 20dB below limit line.		

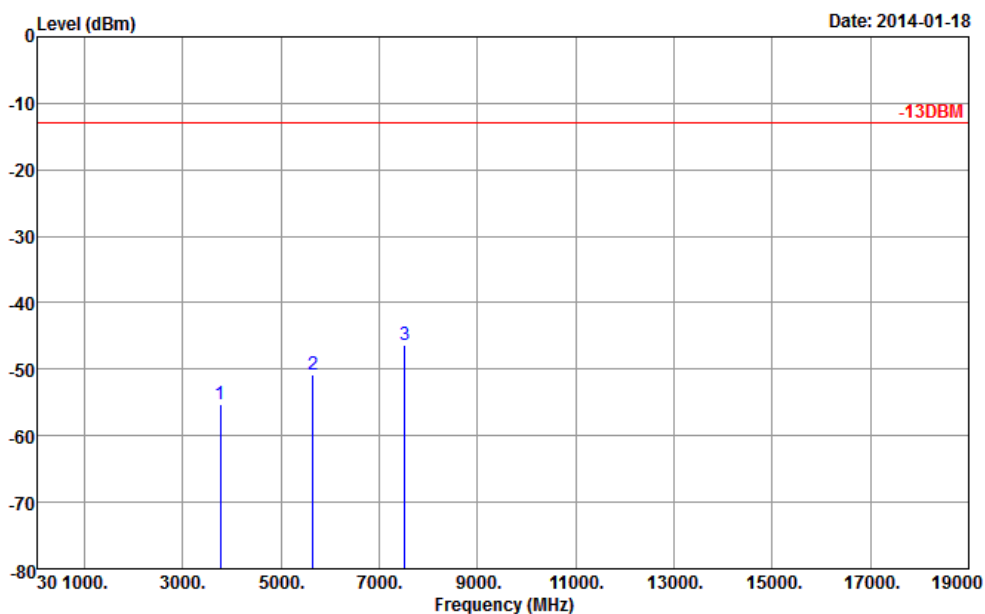

Site : 03CH01-SZ  
 Condition : -13DBM HF\_EIRP\_H\_130101 HORIZONTAL  
 Project : (FG)410803

Frequency ( MHz )	EIRP ( dBm )	Limit ( dBm )	Over Limit ( dB )	SPA Reading ( dBm )	S.G. Power ( dBm )	TX Cable loss ( dB )	TX Antenna Gain ( dBi )	Polarization ( H/V )	Result
3760	-55.25	-13	-42.25	-67.40	-61.99	1.28	8.02	H	Pass
5640	-50.78	-13	-37.78	-68.77	-59.20	1.58	10.00	H	Pass
7520	-46.32	-13	-33.32	-68.26	-56.64	1.78	12.10	H	Pass



<b>Band :</b>	GSM1900 for CH 661	<b>Temperature :</b>	23~24°C
<b>Test Mode :</b>	GSM Link (GMSK)	<b>Relative Humidity :</b>	46~49%
<b>Test Engineer :</b>	Robin Luo	<b>Polarization :</b>	Vertical
<b>Remark :</b>	Spurious emissions within 30-1000MHz were found more than 20dB below limit line.		

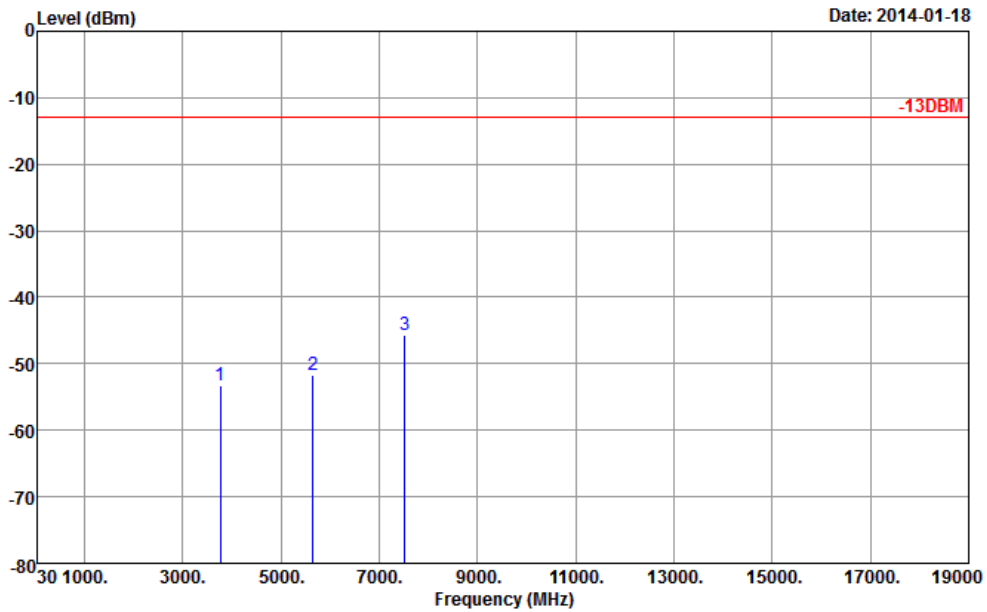

Site : 03CH01-SZ  
 Condition : -13DBM HF\_EIRP\_V\_130101 VERTICAL  
 Project : (FG)410803

Frequency ( MHz )	EIRP ( dBm )	Limit ( dBm )	Over Limit ( dB )	SPA Reading ( dBm )	S.G. Power ( dBm )	TX Cable loss ( dB )	TX Antenna Gain ( dBi )	Polarization ( H/V )	Result
3760	-53.15	-13	-40.15	-68.18	-59.89	1.28	8.02	V	Pass
5640	-51.77	-13	-38.77	-68.85	-60.19	1.58	10	V	Pass
7520	-45.79	-13	-32.79	-68.04	-56.11	1.78	12.1	V	Pass



<b>Band :</b>	GSM1900 for CH 810	<b>Temperature :</b>	23~24°C
<b>Test Mode :</b>	GSM Link (GMSK)	<b>Relative Humidity :</b>	46~49%
<b>Test Engineer :</b>	Robin Luo	<b>Polarization :</b>	Horizontal
<b>Remark :</b>	Spurious emissions within 30-1000MHz were found more than 20dB below limit line.		

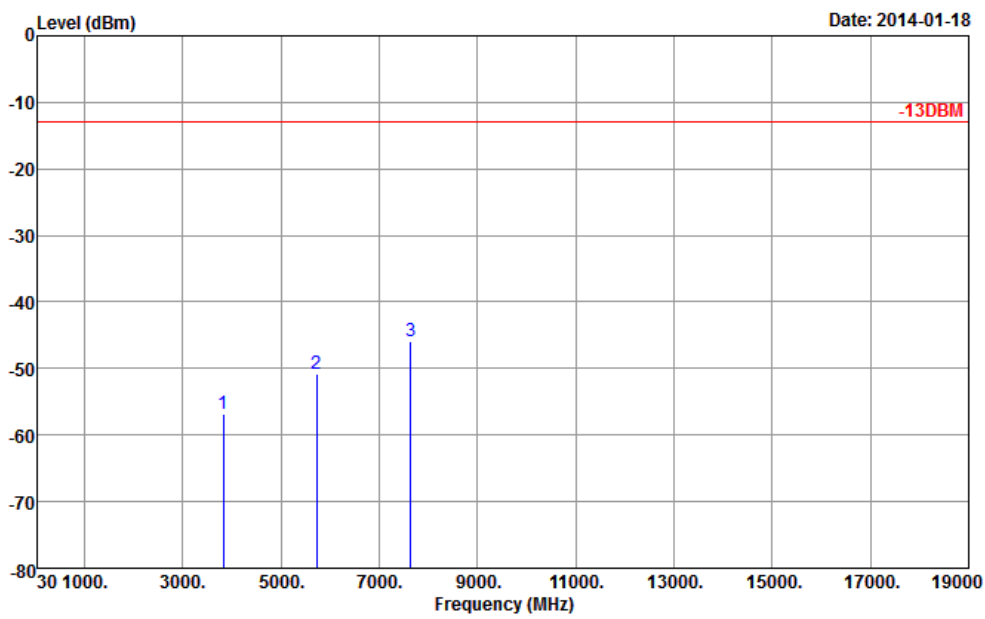

Site : 03CH01-SZ  
 Condition : -13DBM HF\_EIRP\_H\_130101 HORIZONTAL  
 Project : (FG)410803

Frequency ( MHz )	EIRP ( dBm )	Limit ( dBm )	Over Limit ( dB )	SPA Reading ( dBm )	S.G. Power ( dBm )	TX Cable loss ( dB )	TX Antenna Gain ( dBi )	Polarization ( H/V )	Result
3819.6	-56.72	-13	-43.72	-68.29	-63.49	1.23	8.00	H	Pass
5729.4	-50.84	-13	-37.84	-68.64	-58.97	1.52	9.65	H	Pass
7639.2	-45.89	-13	-32.89	-68.13	-56.07	1.82	12.00	H	Pass



<b>Band :</b>	GSM1900 for CH 810	<b>Temperature :</b>	23~24°C
<b>Test Mode :</b>	GSM Link (GMSK)	<b>Relative Humidity :</b>	46~49%
<b>Test Engineer :</b>	Robin Luo	<b>Polarization :</b>	Vertical
<b>Remark :</b>	Spurious emissions within 30-1000MHz were found more than 20dB below limit line.		

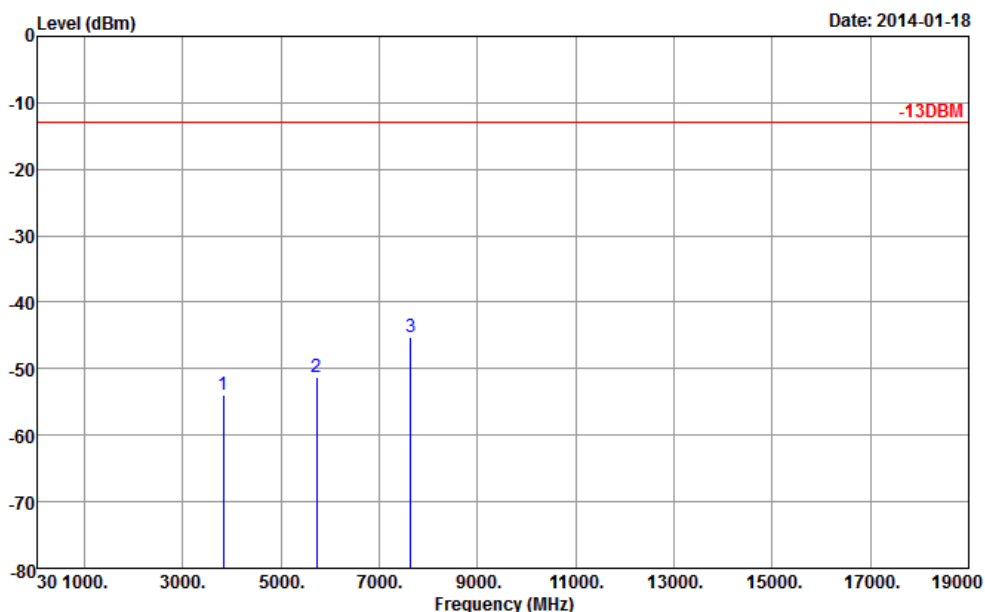

Site : 03CH01-SZ  
 Condition : -13DBM HF\_EIRP\_V\_130101 VERTICAL  
 Project : (FG)410803

Frequency ( MHz )	EIRP ( dBm )	Limit ( dBm )	Over Limit ( dB )	SPA Reading ( dBm )	S.G. Power ( dBm )	TX Cable loss ( dB )	TX Antenna Gain ( dBi )	Polarization ( H/V )	Result
3819.6	-53.88	-13	-40.88	-68.33	-60.65	1.23	8	V	Pass
5729.4	-51.15	-13	-38.15	-68.04	-59.28	1.52	9.65	V	Pass
7639.2	-45.33	-13	-32.33	-67.88	-55.51	1.82	12	V	Pass



<b>Band :</b>	GSM1900 for CH 512	<b>Temperature :</b>	23~24°C
<b>Test Mode :</b>	EDGE class 8 Link (8PSK)	<b>Relative Humidity :</b>	46~49%
<b>Test Engineer :</b>	Robin Luo	<b>Polarization :</b>	Horizontal
<b>Remark :</b>	Spurious emissions within 30-1000MHz were found more than 20dB below limit line.		

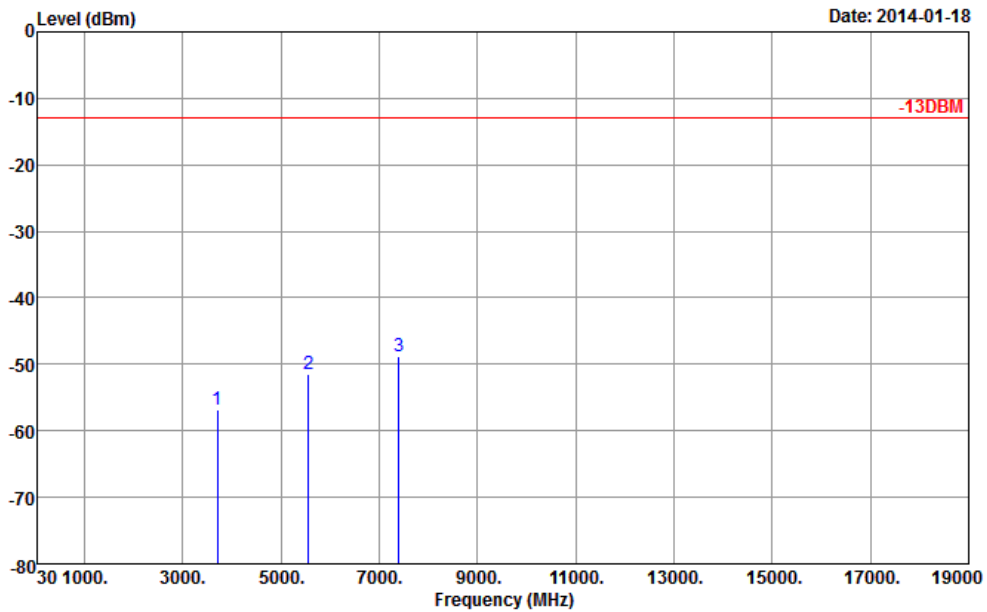

Site : 03CH01-SZ  
 Condition : -13DBM HF\_EIRP\_H\_130101 HORIZONTAL  
 Project : (FG)410803

Frequency ( MHz )	EIRP ( dBm )	Limit ( dBm )	Over Limit ( dB )	SPA Reading ( dBm )	S.G. Power ( dBm )	TX Cable loss ( dB )	TX Antenna Gain ( dBi )	Polarization ( H/V )	Result
3700.4	-56.86	-13	-43.86	-68.41	-63.61	1.2	7.95	H	Pass
5550.6	-51.49	-13	-38.49	-68.88	-59.59	1.5	9.60	H	Pass
7400.8	-48.90	-13	-35.90	-70.48	-59.09	1.7	11.89	H	Pass



<b>Band :</b>	GSM1900 for CH 512	<b>Temperature :</b>	23~24°C
<b>Test Mode :</b>	EDGE class 8 Link (8PSK)	<b>Relative Humidity :</b>	46~49%
<b>Test Engineer :</b>	Robin Luo	<b>Polarization :</b>	Vertical
<b>Remark :</b>	Spurious emissions within 30-1000MHz were found more than 20dB below limit line.		

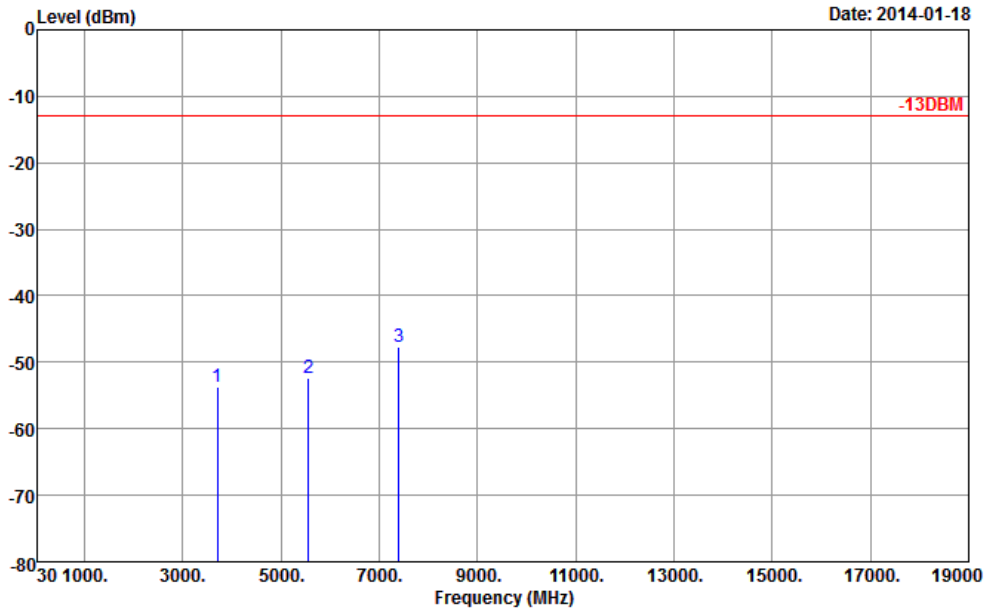

Site : 03CH01-SZ  
 Condition : -13DBM HF\_EIRP\_V\_130101 VERTICAL  
 Project : (FG)410803

Frequency ( MHz )	EIRP ( dBm )	Limit ( dBm )	Over Limit ( dB )	SPA Reading ( dBm )	S.G. Power ( dBm )	TX Cable loss ( dB )	TX Antenna Gain ( dBi )	Polarization ( H/V )	Result
3700.4	-53.64	-13	-40.64	-68.07	-60.39	1.2	7.95	V	Pass
5550.6	-52.37	-13	-39.37	-68.85	-60.47	1.5	9.6	V	Pass
7400.8	-47.70	-13	-34.70	-69.59	-57.89	1.7	11.89	V	Pass



<b>Band :</b>	GSM1900 for CH 661	<b>Temperature :</b>	23~24°C
<b>Test Mode :</b>	EDGE class 8 Link (8PSK)	<b>Relative Humidity :</b>	46~49%
<b>Test Engineer :</b>	Robin Luo	<b>Polarization :</b>	Horizontal
<b>Remark :</b>	Spurious emissions within 30-1000MHz were found more than 20dB below limit line.		

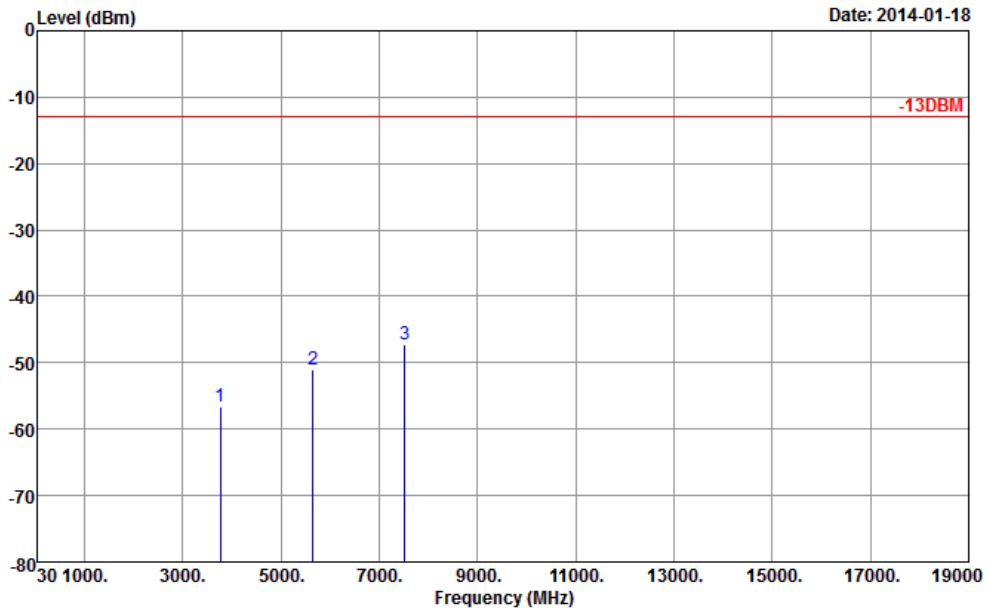

Site : 03CH01-SZ  
 Condition : -13DBM HF\_EIRP\_H\_130101 HORIZONTAL  
 Project : (FG)410803

Frequency ( MHz )	EIRP ( dBm )	Limit ( dBm )	Over Limit ( dB )	SPA Reading ( dBm )	S.G. Power ( dBm )	TX Cable loss ( dB )	TX Antenna Gain ( dBi )	Polarization ( H/V )	Result
3760	-56.58	-13	-43.58	-68.73	-63.32	1.28	8.02	H	Pass
5640	-51.02	-13	-38.02	-69.01	-59.44	1.58	10.00	H	Pass
7520	-47.32	-13	-34.32	-69.26	-57.64	1.78	12.10	H	Pass



<b>Band :</b>	GSM1900 for CH 661	<b>Temperature :</b>	23~24°C
<b>Test Mode :</b>	EDGE class 8 Link (8PSK)	<b>Relative Humidity :</b>	46~49%
<b>Test Engineer :</b>	Robin Luo	<b>Polarization :</b>	Vertical
<b>Remark :</b>	Spurious emissions within 30-1000MHz were found more than 20dB below limit line.		

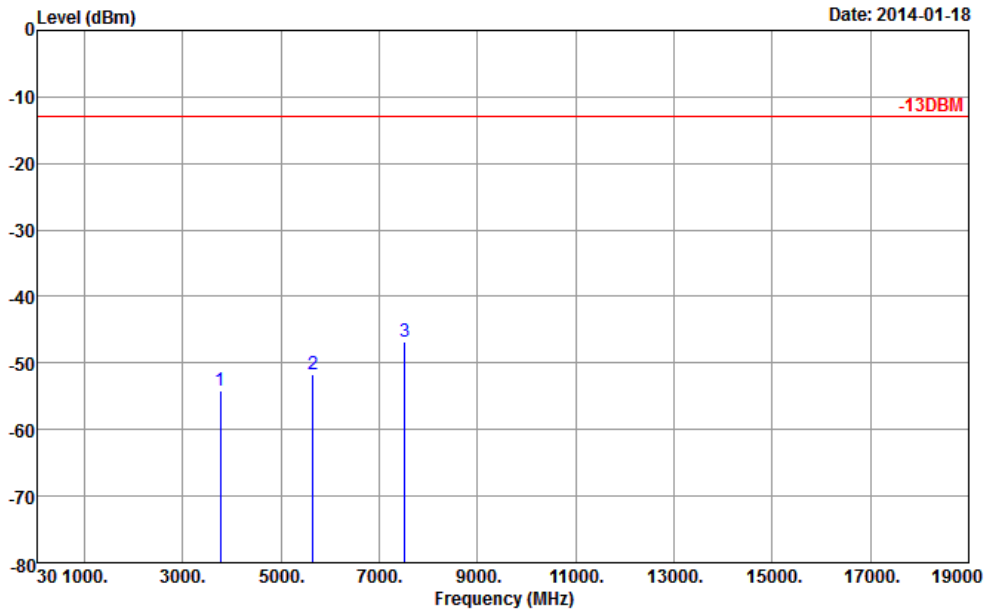

Site : 03CH01-SZ  
 Condition : -13DBM HF\_EIRP\_V\_130101 VERTICAL  
 Project : (FG)410803

Frequency ( MHz )	EIRP ( dBm )	Limit ( dBm )	Over Limit ( dB )	SPA Reading ( dBm )	S.G. Power ( dBm )	TX Cable loss ( dB )	TX Antenna Gain ( dBi )	Polarization ( H/V )	Result
3760	-54.11	-13	-41.11	-69.14	-60.85	1.28	8.02	V	Pass
5640	-51.59	-13	-38.59	-68.67	-60.01	1.58	10	V	Pass
7520	-46.79	-13	-33.79	-69.04	-57.11	1.78	12.1	V	Pass



<b>Band :</b>	GSM1900 for CH 810	<b>Temperature :</b>	23~24°C
<b>Test Mode :</b>	EDGE class 8 Link (8PSK)	<b>Relative Humidity :</b>	46~49%
<b>Test Engineer :</b>	Robin Luo	<b>Polarization :</b>	Horizontal
<b>Remark :</b>	Spurious emissions within 30-1000MHz were found more than 20dB below limit line.		

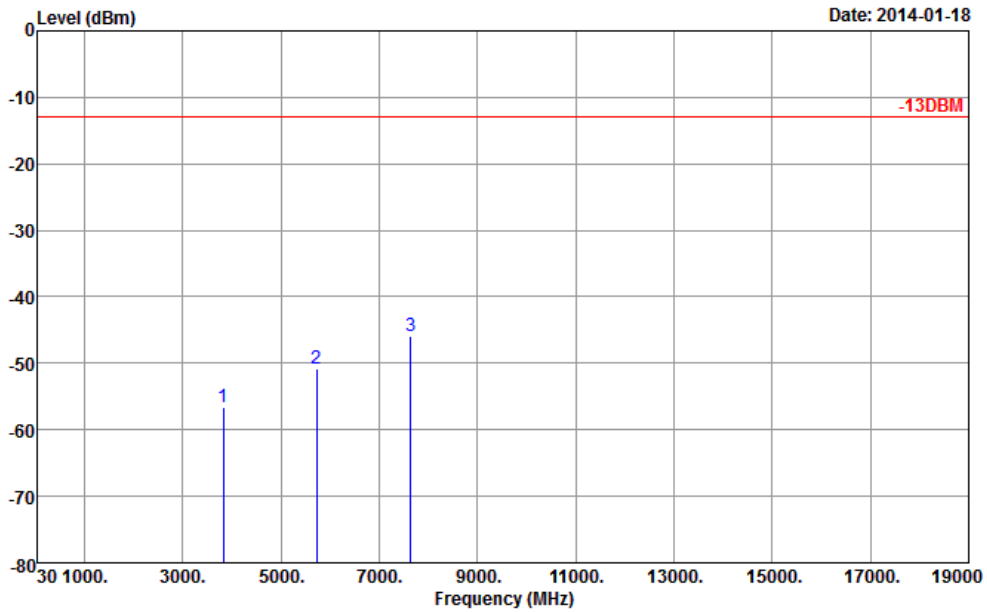

Site : 03CH01-SZ  
 Condition : -13DBM HF\_EIRP\_H\_130101 HORIZONTAL  
 Project : (FG)410803

Frequency ( MHz )	EIRP ( dBm )	Limit ( dBm )	Over Limit ( dB )	SPA Reading ( dBm )	S.G. Power ( dBm )	TX Cable loss ( dB )	TX Antenna Gain ( dBi )	Polarization ( H/V )	Result
3819.6	-56.61	-13	-43.61	-68.18	-63.38	1.23	8.00	H	Pass
5729.4	-50.86	-13	-37.86	-68.66	-58.99	1.52	9.65	H	Pass
7639.2	-45.94	-13	-32.94	-68.18	-56.12	1.82	12.00	H	Pass



<b>Band :</b>	GSM1900 for CH 810	<b>Temperature :</b>	23~24°C
<b>Test Mode :</b>	EDGE class 8 Link (8PSK)	<b>Relative Humidity :</b>	46~49%
<b>Test Engineer :</b>	Robin Luo	<b>Polarization :</b>	Vertical
<b>Remark :</b>	Spurious emissions within 30-1000MHz were found more than 20dB below limit line.		

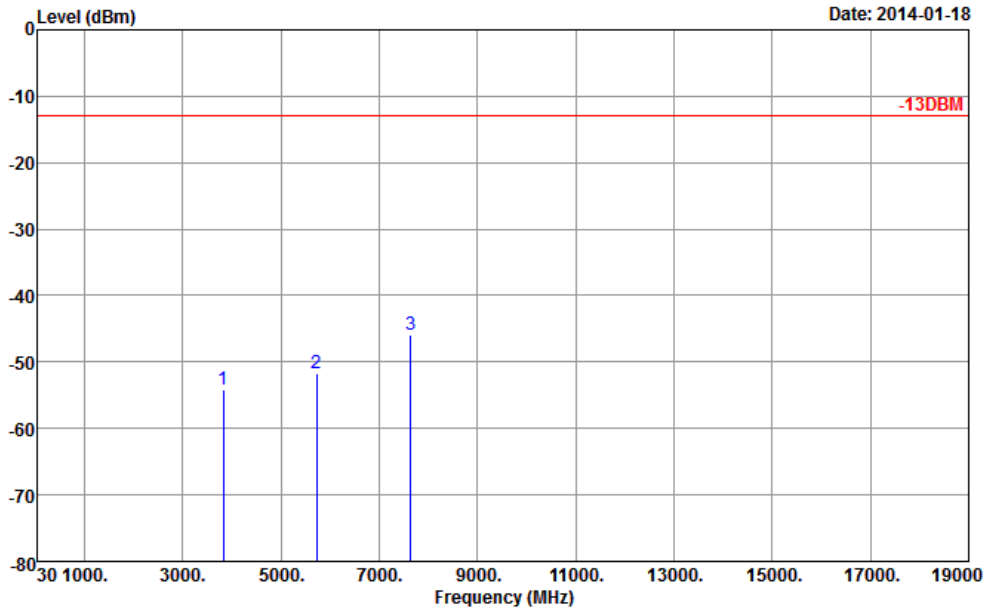

Site : 03CH01-SZ  
 Condition : -13DBM HF\_EIRP\_V\_130101 VERTICAL  
 Project : (FG)410803

Frequency ( MHz )	EIRP ( dBm )	Limit ( dBm )	Over Limit ( dB )	SPA Reading ( dBm )	S.G. Power ( dBm )	TX Cable loss ( dB )	TX Antenna Gain ( dBi )	Polarization ( H/V )	Result
3819.6	-54.18	-13	-41.18	-68.63	-60.95	1.23	8	V	Pass
5729.4	-51.70	-13	-38.70	-68.59	-59.83	1.52	9.65	V	Pass
7639.2	-45.80	-13	-32.80	-68.35	-55.98	1.82	12	V	Pass



<b>Band :</b>	WCDMA Band V for CH 4132	<b>Temperature :</b>	23~24°C
<b>Test Mode :</b>	RMC 12.2Kbps Link (QPSK)	<b>Relative Humidity :</b>	46~49%
<b>Test Engineer :</b>	Robin Luo	<b>Polarization :</b>	Horizontal
<b>Remark :</b>	Spurious emissions within 30-1000MHz were found more than 20dB below limit line.		

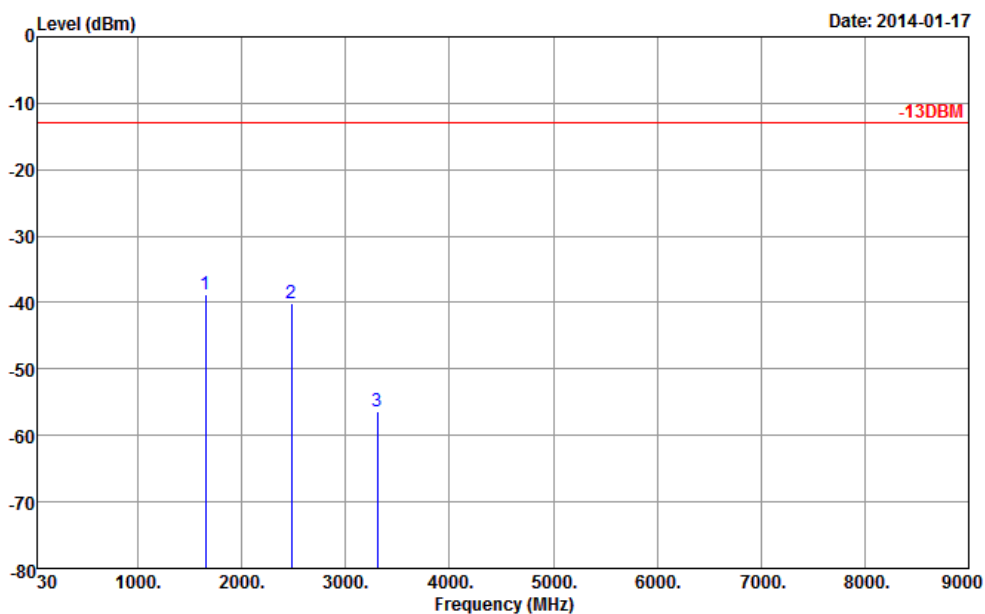

Site : 03CH01-SZ  
 Condition : -13DBM HF\_EIRP\_H\_130101 HORIZONTAL  
 Project : (FG)410803

Frequency ( MHz )	ERP ( dBm )	Limit ( dBm )	Over Limit ( dB )	SPA Reading ( dBm )	S.G. Power ( dBm )	TX Cable loss ( dB )	TX Antenna Gain ( dBi )	Polarization ( H/V )	Result
1652.8	-38.67	-13	-25.67	-56.18	-41.66	0.81	5.95	H	Pass
2479.2	-40.15	-13	-27.15	-64.02	-42.60	1.2	5.80	H	Pass
3305.6	-56.28	-13	-43.28	-66.88	-60.58	1.25	7.70	H	Pass



<b>Band :</b>	WCDMA Band V for CH 4132	<b>Temperature :</b>	23~24°C
<b>Test Mode :</b>	RMC 12.2Kbps Link (QPSK)	<b>Relative Humidity :</b>	46~49%
<b>Test Engineer :</b>	Robin Luo	<b>Polarization :</b>	Vertical
<b>Remark :</b>	Spurious emissions within 30-1000MHz were found more than 20dB below limit line.		

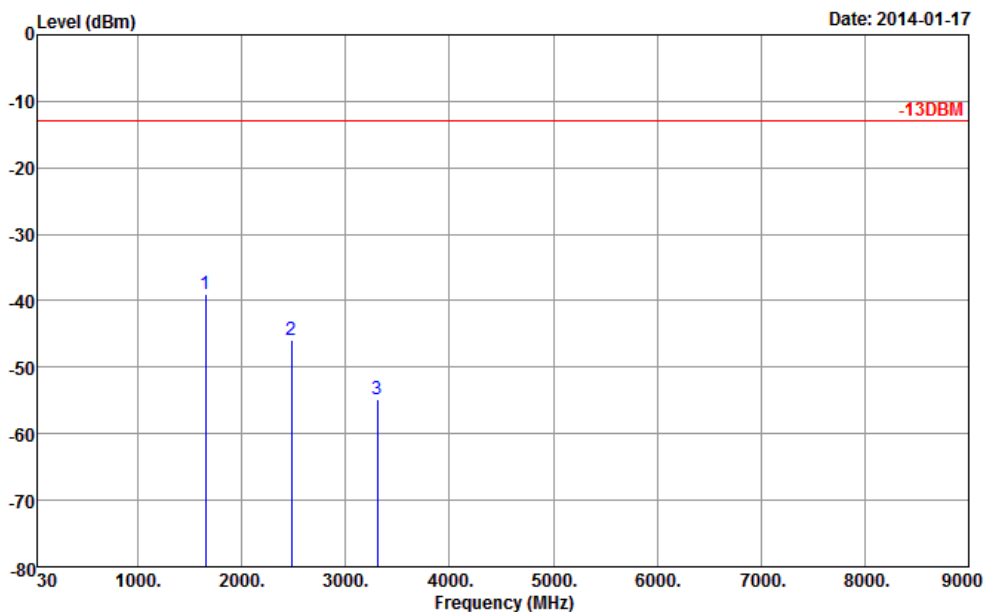

Site : 03CH01-SZ  
 Condition : -13DBM HF\_EIRP\_V\_130101 VERTICAL  
 Project : (FG)410803

Frequency ( MHz )	ERP ( dBm )	Limit ( dBm )	Over Limit ( dB )	SPA Reading ( dBm )	S.G. Power ( dBm )	TX Cable loss ( dB )	TX Antenna Gain ( dBi )	Polarization ( H/V )	Result
1652.8	-39.10	-13	-26.10	-53.47	-42.09	0.81	5.95	V	Pass
2479.2	-45.84	-13	-32.84	-66.43	-48.29	1.20	5.80	V	Pass
3305.6	-54.87	-13	-41.87	-66.70	-59.17	1.25	7.70	V	Pass



<b>Band :</b>	WCDMA Band V for CH 4182	<b>Temperature :</b>	23~24°C
<b>Test Mode :</b>	RMC 12.2Kbps Link (QPSK)	<b>Relative Humidity :</b>	46~49%
<b>Test Engineer :</b>	Robin Luo	<b>Polarization :</b>	Horizontal
<b>Remark :</b>	Spurious emissions within 30-1000MHz were found more than 20dB below limit line.		

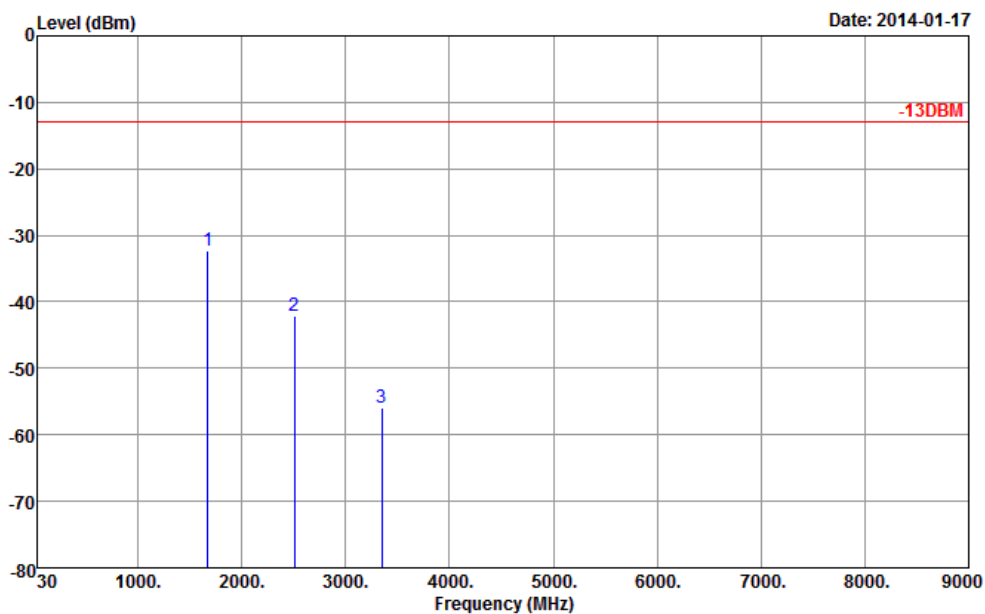

Site : 03CH01-SZ  
 Condition : -13DBM HF\_EIRP\_H\_130101 HORIZONTAL  
 Project : (FG)410803

Frequency ( MHz )	ERP ( dBm )	Limit ( dBm )	Over Limit ( dB )	SPA Reading ( dBm )	S.G. Power ( dBm )	TX Cable loss ( dB )	TX Antenna Gain ( dBi )	Polarization ( H/V )	Result
1672	-32.38	-13	-19.38	-48.97	-35.35	0.88	6.00	H	Pass
2510	-42.01	-13	-29.01	-65.90	-44.62	1.08	5.84	H	Pass
3346	-55.84	-13	-42.84	-66.44	-60.21	1.14	7.66	H	Pass



<b>Band :</b>	WCDMA Band V for CH 4182	<b>Temperature :</b>	23~24°C
<b>Test Mode :</b>	RMC 12.2Kbps Link (QPSK)	<b>Relative Humidity :</b>	46~49%
<b>Test Engineer :</b>	Robin Luo	<b>Polarization :</b>	Vertical
<b>Remark :</b>	Spurious emissions within 30-1000MHz were found more than 20dB below limit line.		

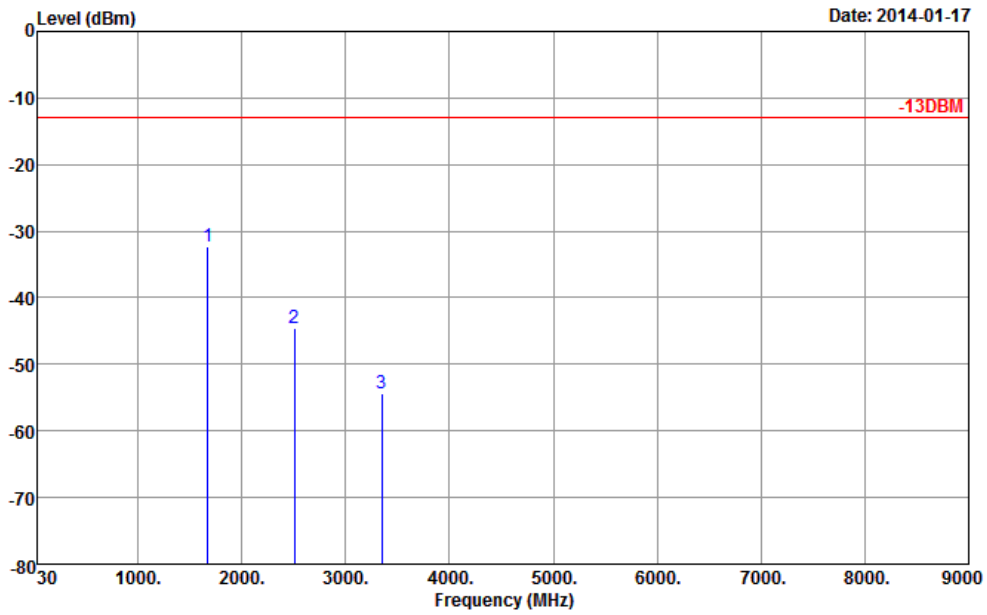

Site : 03CH01-SZ  
 Condition : -13DBM HF\_EIRP\_V\_130101 VERTICAL  
 Project : (FG)410803

Frequency ( MHz )	ERP ( dBm )	Limit ( dBm )	Over Limit ( dB )	SPA Reading ( dBm )	S.G. Power ( dBm )	TX Cable loss ( dB )	TX Antenna Gain ( dBi )	Polarization ( H/V )	Result
1672	-32.39	-13	-19.39	-46.47	-35.36	0.88	6.00	V	Pass
2510	-44.52	-13	-31.52	-65.91	-47.13	1.08	5.84	V	Pass
3346	-54.34	-13	-41.34	-66.17	-58.71	1.14	7.66	V	Pass



<b>Band :</b>	WCDMA Band V for CH 4233	<b>Temperature :</b>	23~24°C
<b>Test Mode :</b>	RMC 12.2Kbps Link (QPSK)	<b>Relative Humidity :</b>	46~49%
<b>Test Engineer :</b>	Robin Luo	<b>Polarization :</b>	Horizontal
<b>Remark :</b>	Spurious emissions within 30-1000MHz were found more than 20dB below limit line.		

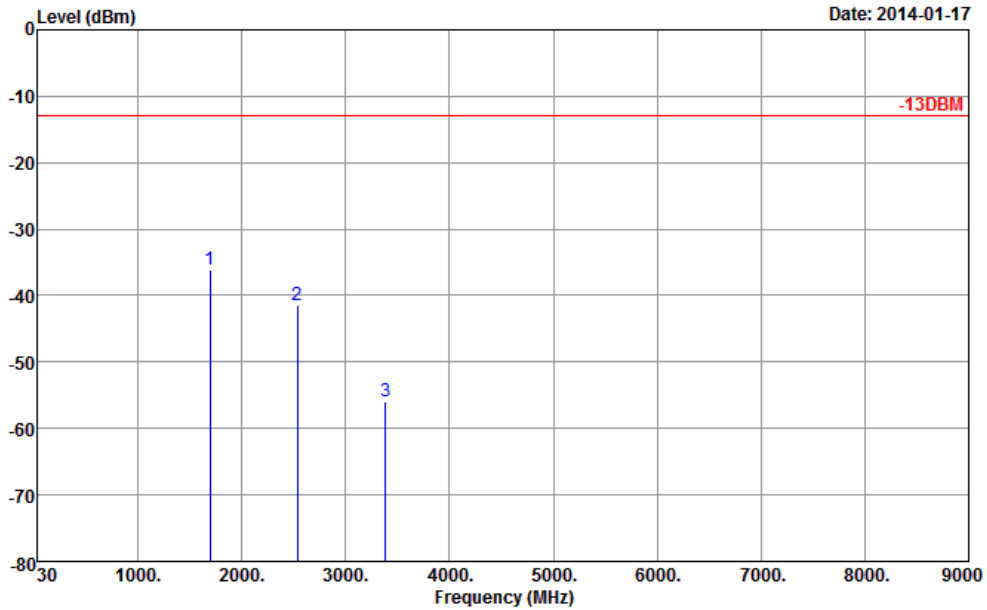

Site : 03CH01-SZ  
 Condition : -13DBM HF\_EIRP\_H\_130101 HORIZONTAL  
 Project : (FG)410803

Frequency ( MHz )	ERP ( dBm )	Limit ( dBm )	Over Limit ( dB )	SPA Reading ( dBm )	S.G. Power ( dBm )	TX Cable loss ( dB )	TX Antenna Gain ( dBi )	Polarization ( H/V )	Result
1693.2	-36.10	-13	-23.10	-53.59	-39.43	0.82	6.30	H	Pass
2539.8	-41.41	-13	-28.41	-65.43	-44.02	1.08	5.84	H	Pass
3386.4	-56.00	-13	-43.00	-66.89	-60.12	1.23	7.50	H	Pass



<b>Band :</b>	WCDMA Band V for CH 4233	<b>Temperature :</b>	23~24°C
<b>Test Mode :</b>	RMC 12.2Kbps Link (QPSK)	<b>Relative Humidity :</b>	46~49%
<b>Test Engineer :</b>	Robin Luo	<b>Polarization :</b>	Vertical
<b>Remark :</b>	Spurious emissions within 30-1000MHz were found more than 20dB below limit line.		

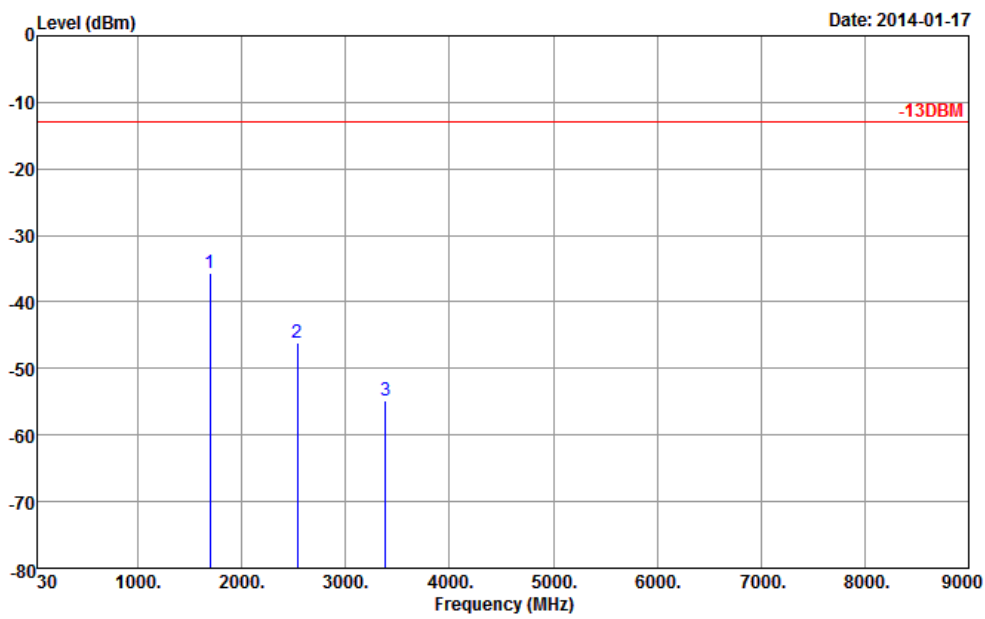

Site : 03CH01-SZ  
 Condition : -13DBM HF\_EIRP\_V\_130101 VERTICAL  
 Project : (FG)410803

Frequency ( MHz )	ERP ( dBm )	Limit ( dBm )	Over Limit ( dB )	SPA Reading ( dBm )	S.G. Power ( dBm )	TX Cable loss ( dB )	TX Antenna Gain ( dBi )	Polarization ( H/V )	Result
1693.2	-35.60	-13	-22.60	-50.25	-38.93	0.82	6.30	V	Pass
2539.8	-46.05	-13	-33.05	-67.02	-48.66	1.08	5.84	V	Pass
3386.4	-54.93	-13	-41.93	-67.05	-59.05	1.23	7.50	V	Pass



<b>Band :</b>	WCDMA Band II for CH 9262	<b>Temperature :</b>	23~24°C
<b>Test Mode :</b>	RMC 12.2Kbps Link (QPSK)	<b>Relative Humidity :</b>	46~49%
<b>Test Engineer :</b>	Robin Luo	<b>Polarization :</b>	Horizontal
<b>Remark :</b>	Spurious emissions within 30-1000MHz were found more than 20dB below limit line.		

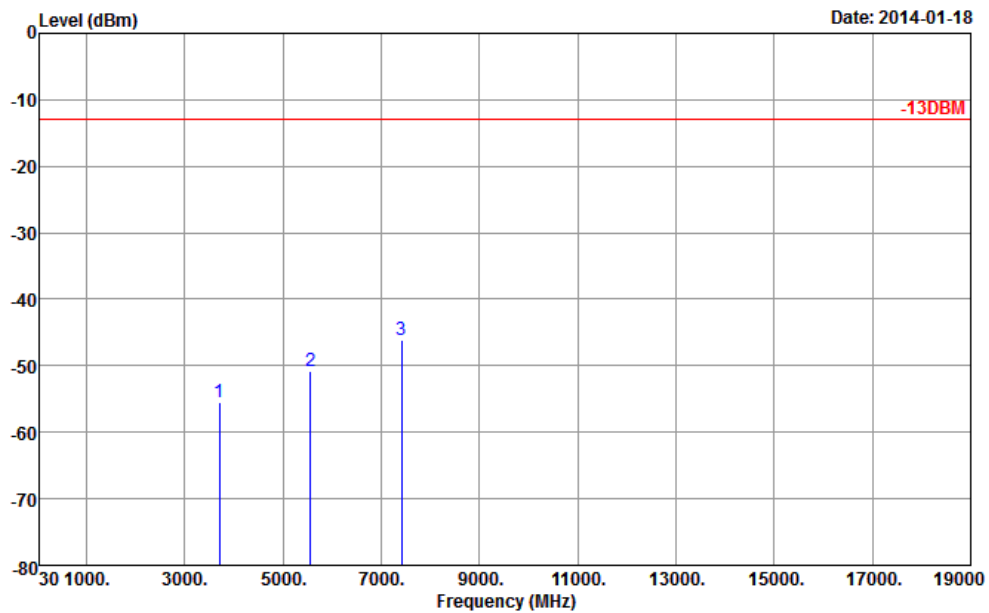

Site : 03CH01-SZ  
 Condition : -13DBM HF\_EIRP\_H\_130101 HORIZONTAL  
 Project : (FG)410803

Frequency ( MHz )	EIRP ( dBm )	Limit ( dBm )	Over Limit ( dB )	SPA Reading ( dBm )	S.G. Power ( dBm )	TX Cable loss ( dB )	TX Antenna Gain ( dBi )	Polarization ( H/V )	Result
3704.8	-55.39	-13	-42.39	-67.25	-62.24	1.35	8.20	H	Pass
5557.2	-50.73	-13	-37.73	-68.46	-59.34	1.65	10.26	H	Pass
7409.6	-46.15	-13	-33.15	-68.59	-56.49	1.82	12.16	H	Pass



<b>Band :</b>	WCDMA Band II for CH 9262	<b>Temperature :</b>	23~24°C
<b>Test Mode :</b>	RMC 12.2Kbps Link (QPSK)	<b>Relative Humidity :</b>	46~49%
<b>Test Engineer :</b>	Robin Luo	<b>Polarization :</b>	Vertical
<b>Remark :</b>	Spurious emissions within 30-1000MHz were found more than 20dB below limit line.		

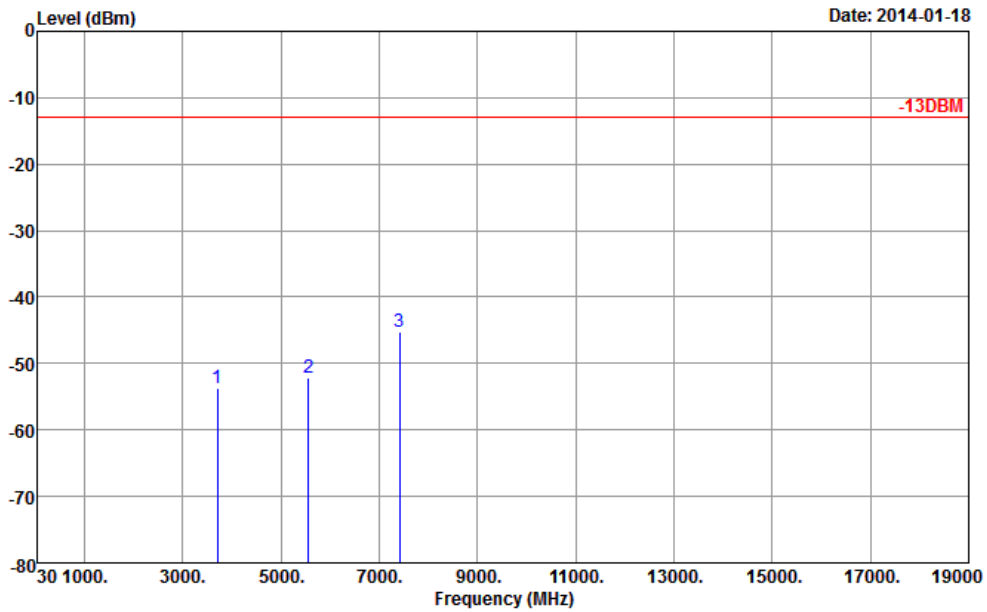

Site : 03CH01-SZ  
 Condition : -13DBM HF\_EIRP\_V\_130101 VERTICAL  
 Project : (FG)410803

Frequency ( MHz )	EIRP ( dBm )	Limit ( dBm )	Over Limit ( dB )	SPA Reading ( dBm )	S.G. Power ( dBm )	TX Cable loss ( dB )	TX Antenna Gain ( dBi )	Polarization ( H/V )	Result
3704.8	-53.67	-13	-40.67	-68.41	-60.52	1.35	8.2	V	Pass
5557.2	-52.24	-13	-39.24	-69.06	-60.85	1.65	10.26	V	Pass
7409.6	-45.22	-13	-32.22	-67.97	-55.56	1.82	12.16	V	Pass



<b>Band :</b>	WCDMA Band II for CH 9400	<b>Temperature :</b>	23~24°C
<b>Test Mode :</b>	RMC 12.2Kbps Link (QPSK)	<b>Relative Humidity :</b>	46~49%
<b>Test Engineer :</b>	Robin Luo	<b>Polarization :</b>	Horizontal
<b>Remark :</b>	Spurious emissions within 30-1000MHz were found more than 20dB below limit line.		

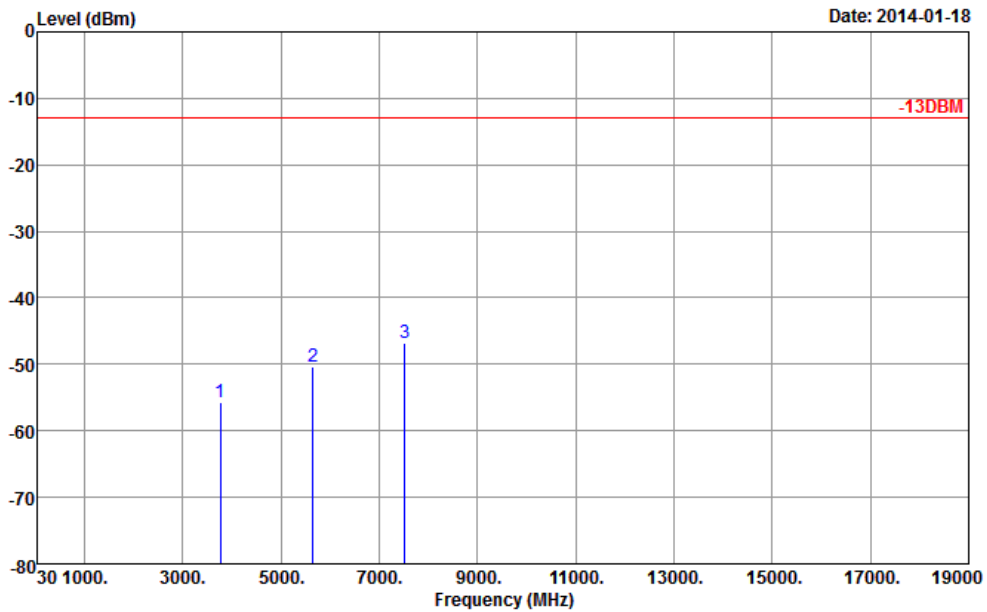

Site : 03CH01-SZ  
 Condition : -13DBM HF\_EIRP\_H\_130101 HORIZONTAL  
 Project : (FG)410803

Frequency ( MHz )	EIRP ( dBm )	Limit ( dBm )	Over Limit ( dB )	SPA Reading ( dBm )	S.G. Power ( dBm )	TX Cable loss ( dB )	TX Antenna Gain ( dBi )	Polarization ( H/V )	Result
3760	-55.78	-13	-42.78	-67.93	-62.52	1.28	8.02	H	Pass
5640	-50.30	-13	-37.30	-68.29	-58.72	1.58	10.00	H	Pass
7520	-46.74	-13	-33.74	-68.68	-57.06	1.78	12.10	H	Pass



<b>Band :</b>	WCDMA Band II for CH 9400	<b>Temperature :</b>	23~24°C
<b>Test Mode :</b>	RMC 12.2Kbps Link (QPSK)	<b>Relative Humidity :</b>	46~49%
<b>Test Engineer :</b>	Robin Luo	<b>Polarization :</b>	Vertical
<b>Remark :</b>	Spurious emissions within 30-1000MHz were found more than 20dB below limit line.		

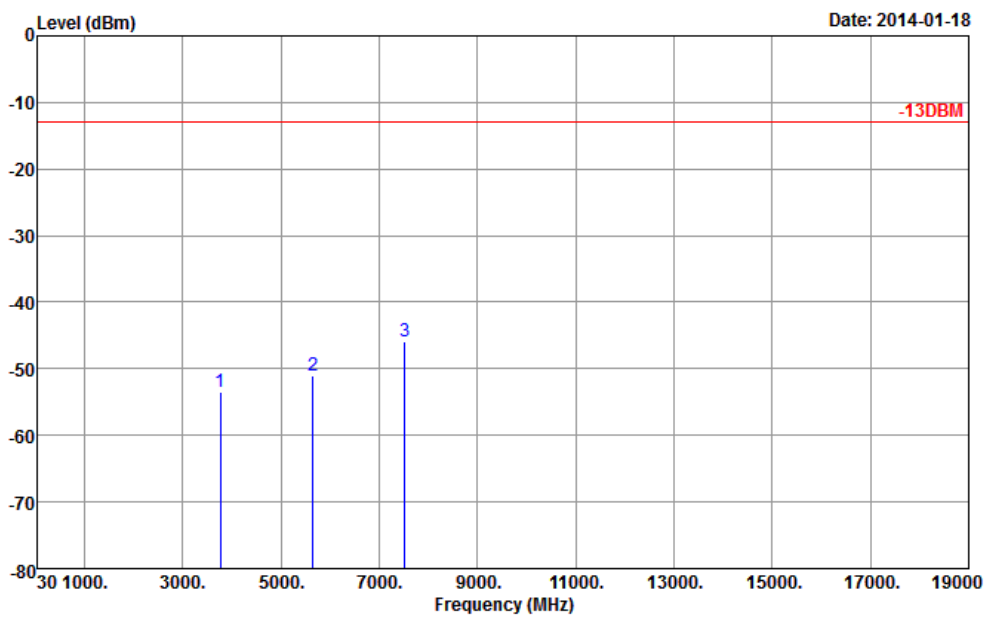

Site : 03CH01-SZ  
 Condition : -13DBM HF\_EIRP\_V\_130101 VERTICAL  
 Project : (FG410803)

Frequency ( MHz )	EIRP ( dBm )	Limit ( dBm )	Over Limit ( dB )	SPA Reading ( dBm )	S.G. Power ( dBm )	TX Cable loss ( dB )	TX Antenna Gain ( dBi )	Polarization ( H/V )	Result
3760	-53.39	-13	-40.39	-68.42	-60.13	1.28	8.02	V	Pass
5640	-51.06	-13	-38.06	-68.14	-59.48	1.58	10	V	Pass
7520	-45.83	-13	-32.83	-68.08	-56.15	1.78	12.1	V	Pass



<b>Band :</b>	WCDMA Band II for CH 9538	<b>Temperature :</b>	23~24°C
<b>Test Mode :</b>	RMC 12.2Kbps Link (QPSK)	<b>Relative Humidity :</b>	46~49%
<b>Test Engineer :</b>	Robin Luo	<b>Polarization :</b>	Horizontal
<b>Remark :</b>	Spurious emissions within 30-1000MHz were found more than 20dB below limit line.		

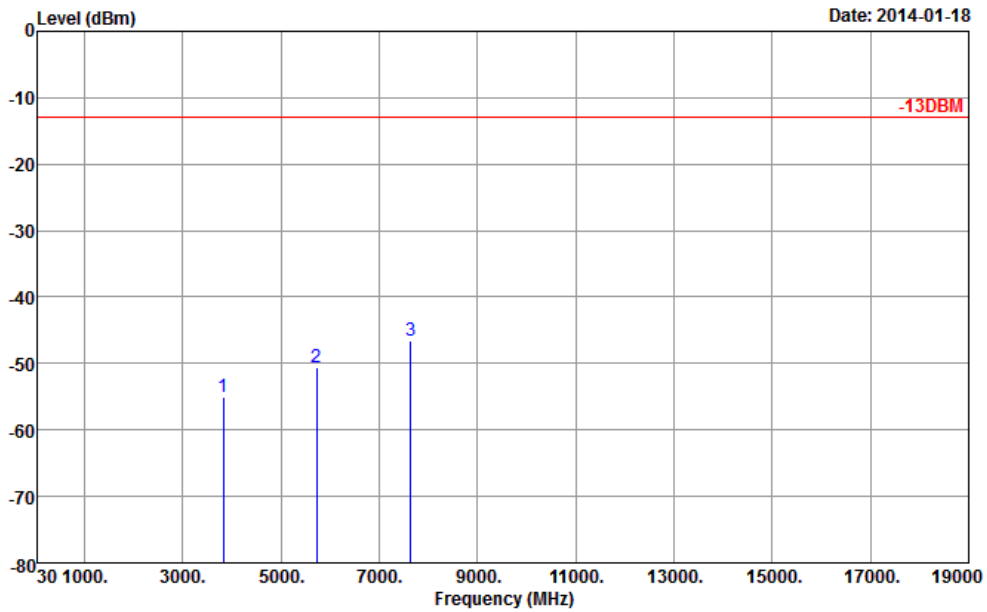

Site : 03CH01-SZ  
 Condition : -13DBM HF\_EIRP\_H\_130101 HORIZONTAL  
 Project : (FG)410803

Frequency ( MHz )	EIRP ( dBm )	Limit ( dBm )	Over Limit ( dB )	SPA Reading ( dBm )	S.G. Power ( dBm )	TX Cable loss ( dB )	TX Antenna Gain ( dBi )	Polarization ( H/V )	Result
3815.2	-55.09	-13	-42.09	-67.24	-61.83	1.28	8.02	H	Pass
5722.8	-50.58	-13	-37.58	-68.57	-59.00	1.58	10.00	H	Pass
7630.4	-46.49	-13	-33.49	-68.43	-56.81	1.78	12.10	H	Pass



<b>Band :</b>	WCDMA Band II for CH 9538	<b>Temperature :</b>	23~24°C
<b>Test Mode :</b>	RMC 12.2Kbps Link (QPSK)	<b>Relative Humidity :</b>	46~49%
<b>Test Engineer :</b>	Robin Luo	<b>Polarization :</b>	Vertical
<b>Remark :</b>	Spurious emissions within 30-1000MHz were found more than 20dB below limit line.		

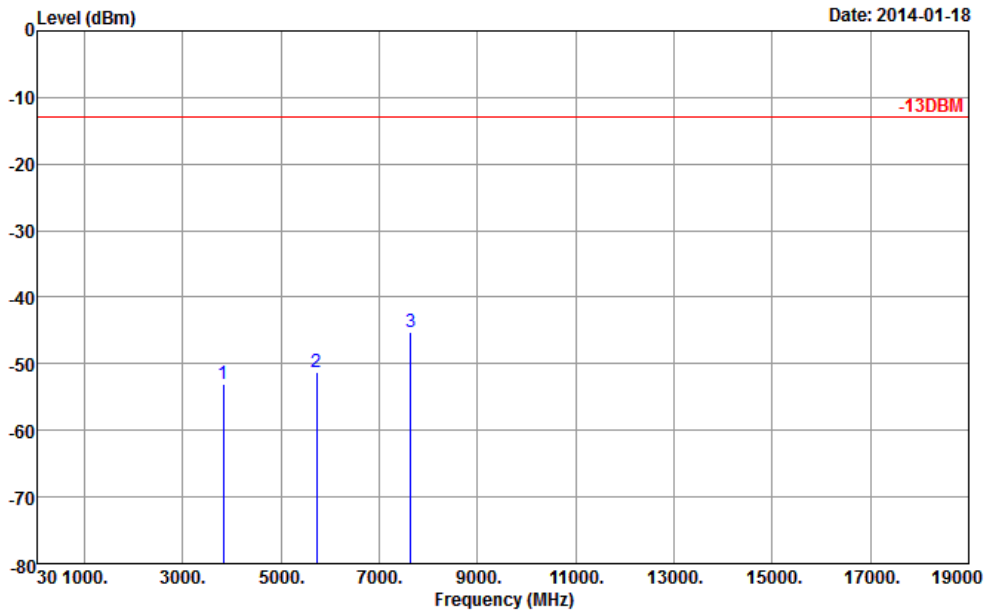

Site : 03CH01-SZ  
 Condition : -13DBM HF\_EIRP\_V\_130101 VERTICAL  
 Project : (FG)410803

Frequency ( MHz )	EIRP ( dBm )	Limit ( dBm )	Over Limit ( dB )	SPA Reading ( dBm )	S.G. Power ( dBm )	TX Cable loss ( dB )	TX Antenna Gain ( dBi )	Polarization ( H/V )	Result
3815.2	-53.14	-13	-40.14	-68.17	-59.88	1.28	8.02	V	Pass
5722.8	-51.22	-13	-38.22	-68.3	-59.64	1.58	10	V	Pass
7630.4	-45.32	-13	-32.32	-67.57	-55.64	1.78	12.1	V	Pass



SIM 2 Card:

Band :	GSM1900 for CH 512	Temperature :	23~24°C
Test Mode :	GSM Link (GMSK)	Relative Humidity :	46~49%
Test Engineer :	Robin Luo	Polarization :	Horizontal
Remark :	Spurious emissions within 30-1000MHz were found more than 20dB below limit line.		

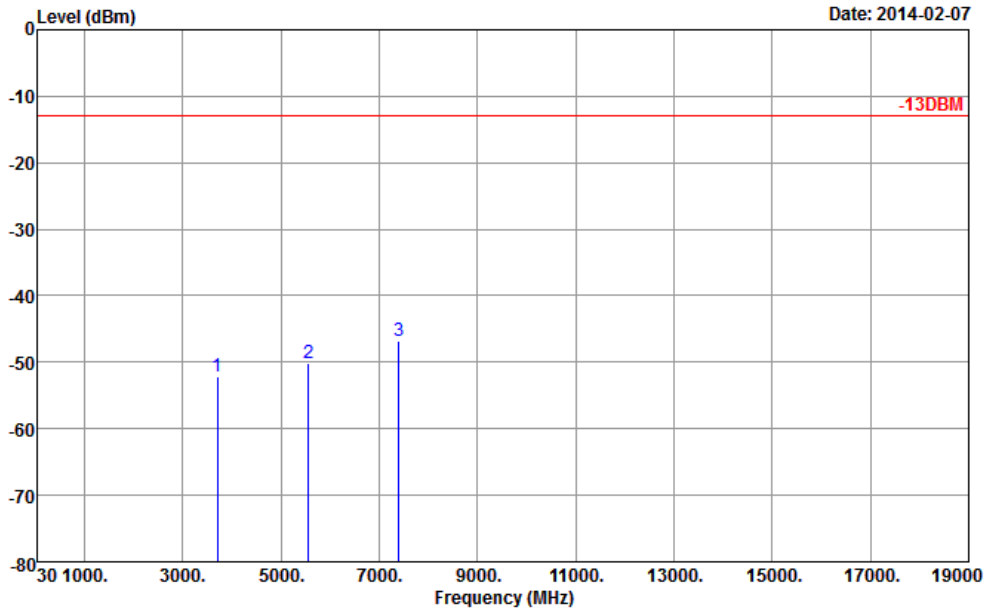

Site : 03CH01-SZ  
 Condition : -13DBM HF\_EIRP\_H\_130101 HORIZONTAL  
 Project : (FG)410803

Frequency ( MHz )	EIRP ( dBm )	Limit ( dBm )	Over Limit ( dB )	SPA Reading ( dBm )	S.G. Power ( dBm )	TX Cable loss ( dB )	TX Antenna Gain ( dBi )	Polarization ( H/V )	Result
3700.4	-52.19	-13	-39.19	-63.74	-58.94	1.2	7.95	H	Pass
5550.6	-50.22	-13	-37.22	-67.61	-58.32	1.5	9.60	H	Pass
7400.8	-46.90	-13	-33.90	-68.48	-57.09	1.7	11.89	H	Pass



<b>Band :</b>	GSM1900 for CH 512	<b>Temperature :</b>	23~24°C
<b>Test Mode :</b>	GSM Link (GMSK)	<b>Relative Humidity :</b>	46~49%
<b>Test Engineer :</b>	Robin Luo	<b>Polarization :</b>	Vertical
<b>Remark :</b>	Spurious emissions within 30-1000MHz were found more than 20dB below limit line.		

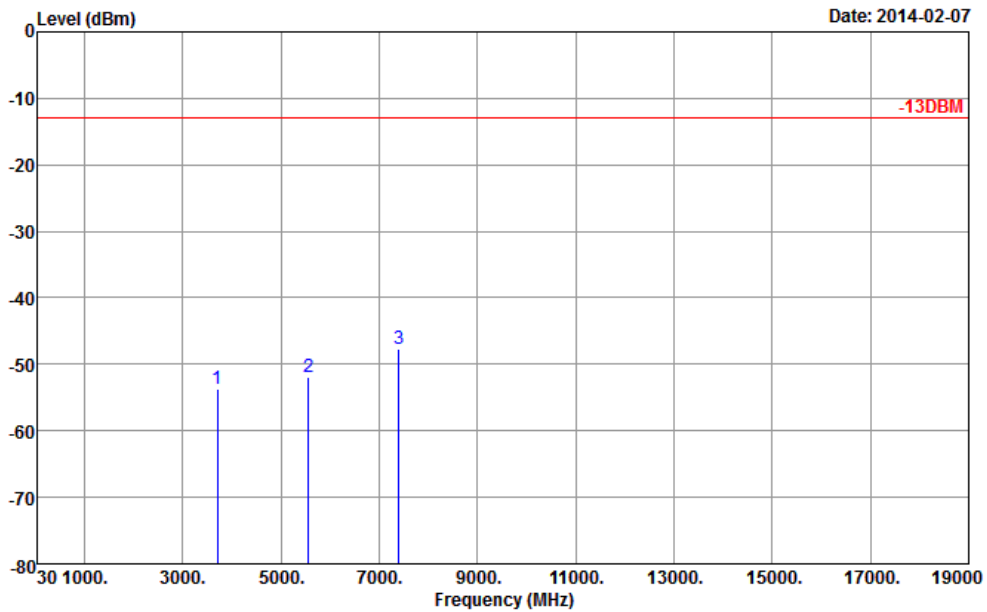

Site : 03CH01-SZ  
 Condition : -13DBM HF\_EIRP\_V\_130101 VERTICAL  
 Project : (FG)410803

Frequency ( MHz )	EIRP ( dBm )	Limit ( dBm )	Over Limit ( dB )	SPA Reading ( dBm )	S.G. Power ( dBm )	TX Cable loss ( dB )	TX Antenna Gain ( dBi )	Polarization ( H/V )	Result
3700.4	-53.74	-13	-40.74	-68.17	-60.49	1.2	7.95	V	Pass
5550.6	-51.84	-13	-38.84	-68.32	-59.94	1.5	9.6	V	Pass
7400.8	-47.70	-13	-34.70	-69.59	-57.89	1.7	11.89	V	Pass



<b>Band :</b>	GSM1900 for CH 661	<b>Temperature :</b>	23~24°C
<b>Test Mode :</b>	GSM Link (GMSK)	<b>Relative Humidity :</b>	46~49%
<b>Test Engineer :</b>	Robin Luo	<b>Polarization :</b>	Horizontal
<b>Remark :</b>	Spurious emissions within 30-1000MHz were found more than 20dB below limit line.		

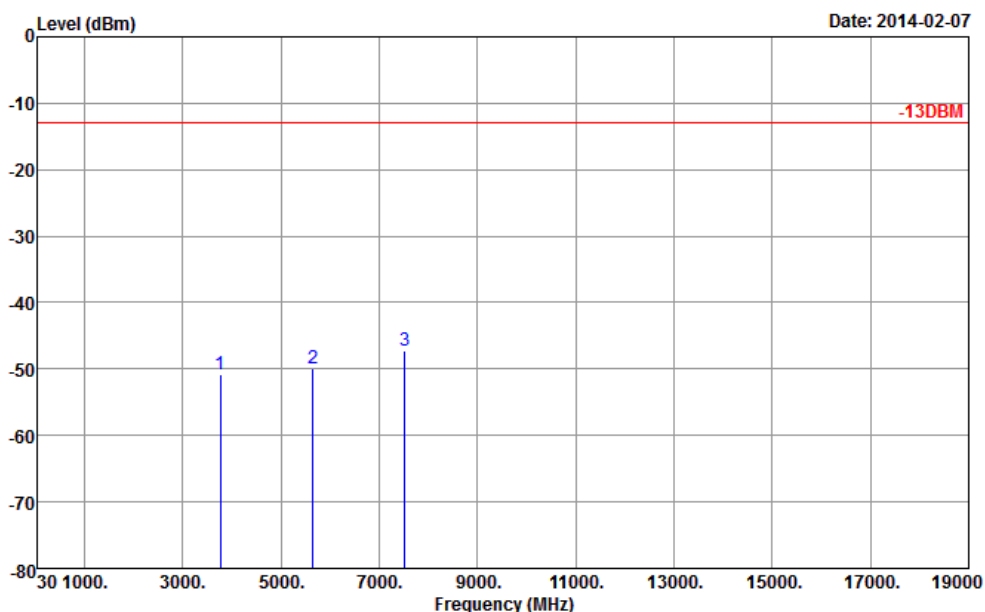

Site : 03CH01-SZ  
 Condition : -13DBM HF\_EIRP\_H\_130101 HORIZONTAL  
 Project : (FG)410803

Frequency ( MHz )	EIRP ( dBm )	Limit ( dBm )	Over Limit ( dB )	SPA Reading ( dBm )	S.G. Power ( dBm )	TX Cable loss ( dB )	TX Antenna Gain ( dBi )	Polarization ( H/V )	Result
3760	-50.84	-13	-37.84	-63.72	-57.58	1.28	8.02	H	Pass
5640	-49.84	-13	-36.84	-67.83	-58.26	1.58	10.00	H	Pass
7520	-47.32	-13	-34.32	-69.26	-57.64	1.78	12.10	H	Pass



<b>Band :</b>	GSM1900 for CH 661	<b>Temperature :</b>	23~24°C
<b>Test Mode :</b>	GSM Link (GMSK)	<b>Relative Humidity :</b>	46~49%
<b>Test Engineer :</b>	Robin Luo	<b>Polarization :</b>	Vertical
<b>Remark :</b>	Spurious emissions within 30-1000MHz were found more than 20dB below limit line.		

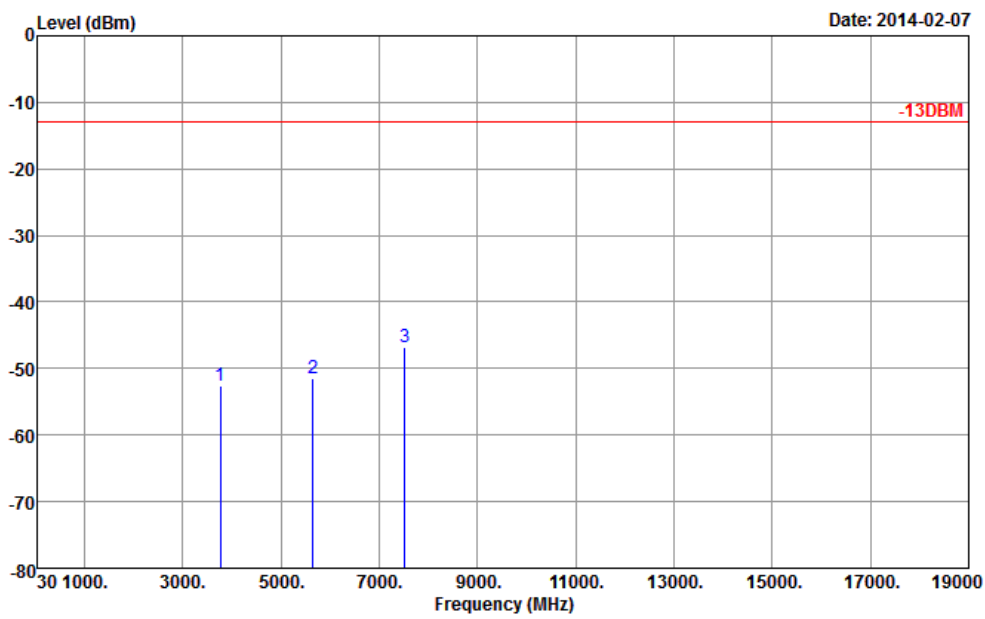

Site : 03CH01-SZ  
 Condition : -13DBM HF\_EIRP\_V\_130101 VERTICAL  
 Project : (FG)410803

Frequency ( MHz )	EIRP ( dBm )	Limit ( dBm )	Over Limit ( dB )	SPA Reading ( dBm )	S.G. Power ( dBm )	TX Cable loss ( dB )	TX Antenna Gain ( dBi )	Polarization ( H/V )	Result
3760	-52.50	-13	-39.50	-67.53	-59.24	1.28	8.02	V	Pass
5640	-51.41	-13	-38.41	-68.49	-59.83	1.58	10	V	Pass
7520	-46.79	-13	-33.79	-69.04	-57.11	1.78	12.1	V	Pass



<b>Band :</b>	GSM1900 for CH 810	<b>Temperature :</b>	23~24°C
<b>Test Mode :</b>	GSM Link (GMSK)	<b>Relative Humidity :</b>	46~49%
<b>Test Engineer :</b>	Robin Luo	<b>Polarization :</b>	Horizontal
<b>Remark :</b>	Spurious emissions within 30-1000MHz were found more than 20dB below limit line.		

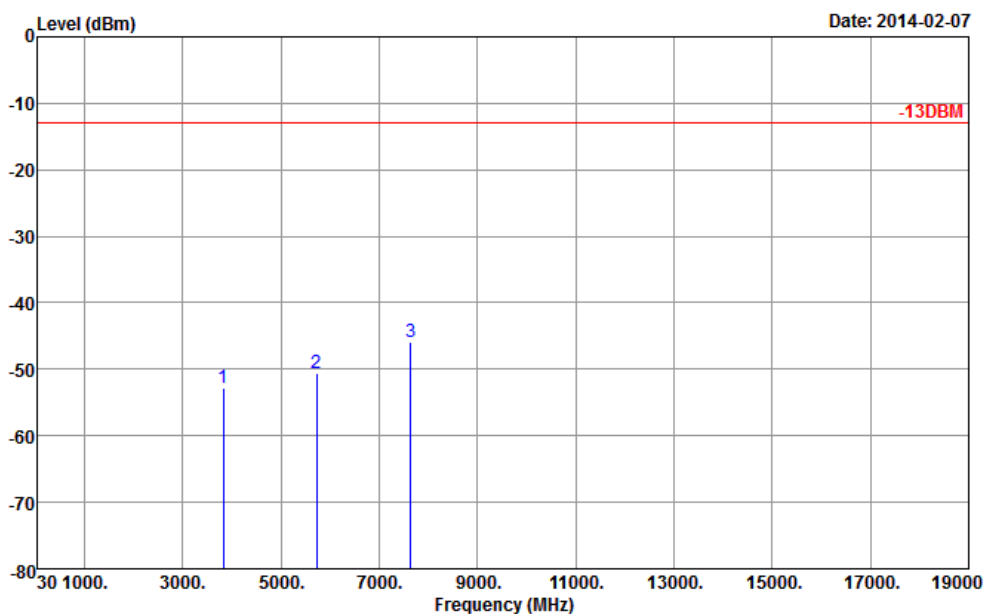

Site : 03CH01-SZ  
 Condition : -13DBM HF\_EIRP\_H\_130101 HORIZONTAL  
 Project : (FG)410803

Frequency ( MHz )	EIRP ( dBm )	Limit ( dBm )	Over Limit ( dB )	SPA Reading ( dBm )	S.G. Power ( dBm )	TX Cable loss ( dB )	TX Antenna Gain ( dBi )	Polarization ( H/V )	Result
3819.6	-52.80	-13	-39.80	-64.37	-59.57	1.23	8.00	H	Pass
5729.4	-50.48	-13	-37.48	-68.28	-58.61	1.52	9.65	H	Pass
7639.2	-45.89	-13	-32.89	-68.13	-56.07	1.82	12.00	H	Pass



<b>Band :</b>	GSM1900 for CH 810	<b>Temperature :</b>	23~24°C
<b>Test Mode :</b>	GSM Link (GMSK)	<b>Relative Humidity :</b>	46~49%
<b>Test Engineer :</b>	Robin Luo	<b>Polarization :</b>	Vertical
<b>Remark :</b>	Spurious emissions within 30-1000MHz were found more than 20dB below limit line.		

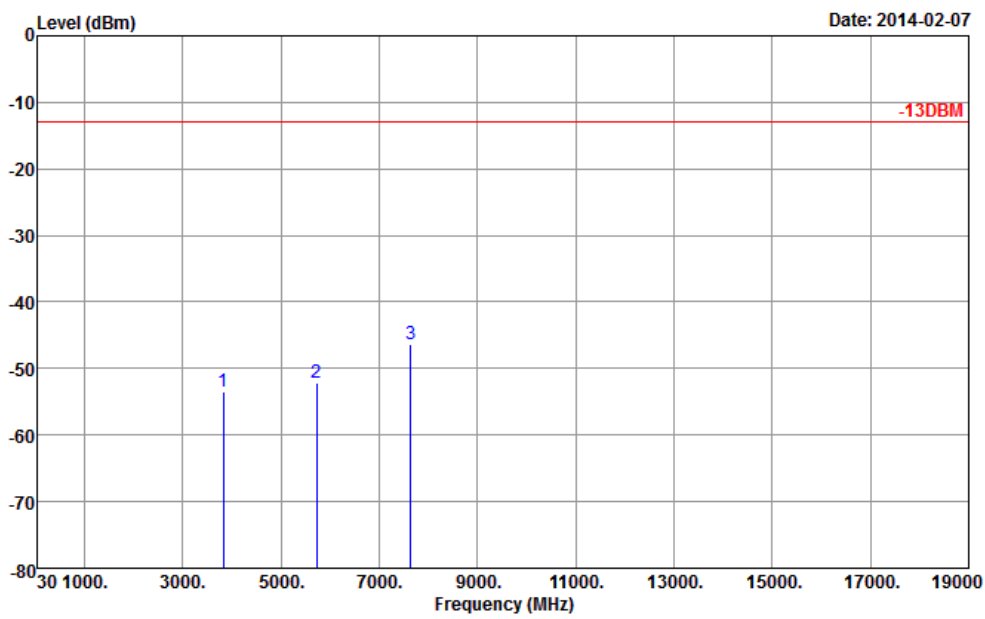

Site : 03CH01-SZ  
 Condition : -13DBM HF\_EIRP\_V\_130101 VERTICAL  
 Project : (FG)410803

Frequency ( MHz )	EIRP ( dBm )	Limit ( dBm )	Over Limit ( dB )	SPA Reading ( dBm )	S.G. Power ( dBm )	TX Cable loss ( dB )	TX Antenna Gain ( dBi )	Polarization ( H/V )	Result
3819.6	-53.55	-13	-40.55	-68	-60.32	1.23	8	V	Pass
5729.4	-52.15	-13	-39.15	-69.04	-60.28	1.52	9.65	V	Pass
7639.2	-46.33	-13	-33.33	-68.88	-56.51	1.82	12	V	Pass



<b>Band :</b>	GSM1900 for CH 512	<b>Temperature :</b>	23~24°C
<b>Test Mode :</b>	EDGE class 8 Link (8PSK)	<b>Relative Humidity :</b>	46~49%
<b>Test Engineer :</b>	Robin Luo	<b>Polarization :</b>	Horizontal
<b>Remark :</b>	Spurious emissions within 30-1000MHz were found more than 20dB below limit line.		

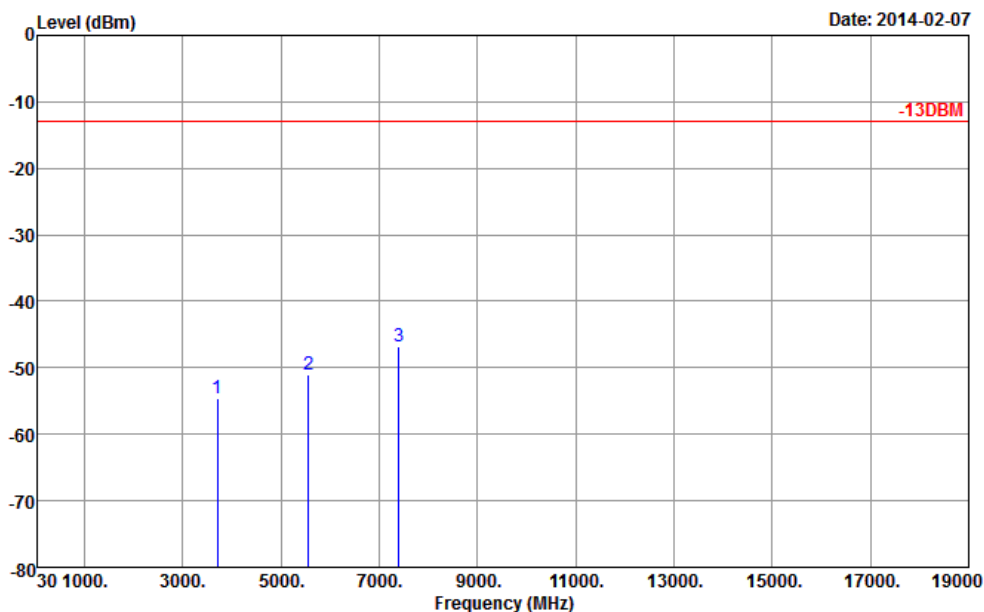

Site : 03CH01-SZ  
 Condition : -13DBM HF\_EIRP\_H\_130101 HORIZONTAL  
 Project : (FG)410803

Frequency ( MHz )	EIRP ( dBm )	Limit ( dBm )	Over Limit ( dB )	SPA Reading ( dBm )	S.G. Power ( dBm )	TX Cable loss ( dB )	TX Antenna Gain ( dBi )	Polarization ( H/V )	Result
3700.4	-54.62	-13	-41.62	-66.17	-61.37	1.2	7.95	H	Pass
5550.6	-51.05	-13	-38.05	-68.44	-59.15	1.5	9.60	H	Pass
7400.8	-46.83	-13	-33.83	-68.41	-57.02	1.7	11.89	H	Pass



<b>Band :</b>	GSM1900 for CH 512	<b>Temperature :</b>	23~24°C
<b>Test Mode :</b>	EDGE class 8 Link (8PSK)	<b>Relative Humidity :</b>	46~49%
<b>Test Engineer :</b>	Robin Luo	<b>Polarization :</b>	Vertical
<b>Remark :</b>	Spurious emissions within 30-1000MHz were found more than 20dB below limit line.		

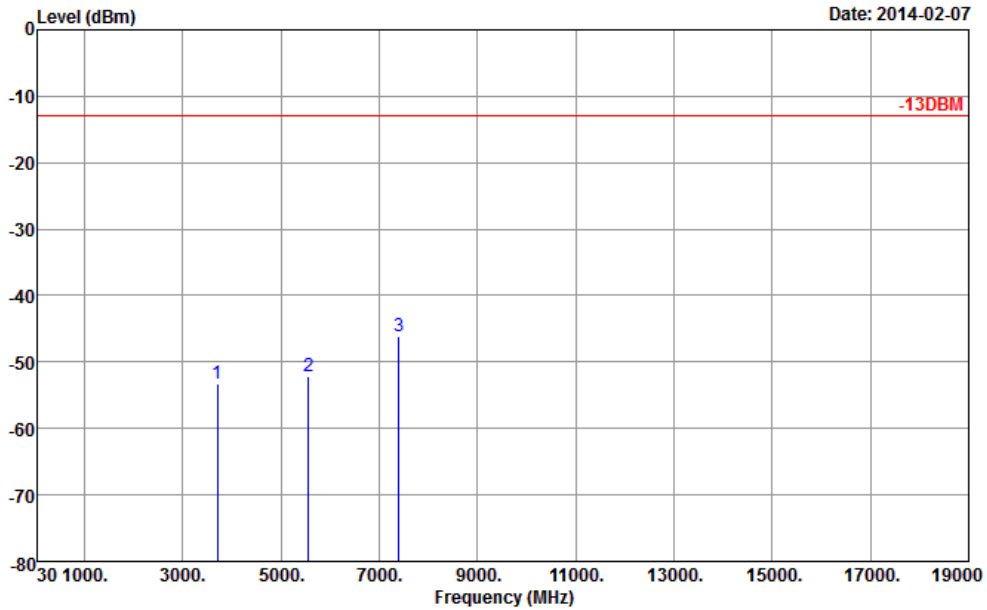

Site : 03CH01-SZ  
 Condition : -13DBM HF\_EIRP\_V\_130101 VERTICAL  
 Project : (FG)410803

Frequency ( MHz )	EIRP ( dBm )	Limit ( dBm )	Over Limit ( dB )	SPA Reading ( dBm )	S.G. Power ( dBm )	TX Cable loss ( dB )	TX Antenna Gain ( dBi )	Polarization ( H/V )	Result
3700.4	-53.23	-13	-40.23	-67.66	-59.98	1.2	7.95	V	Pass
5550.6	-52.05	-13	-39.05	-68.53	-60.15	1.5	9.6	V	Pass
7400.8	-46.12	-13	-33.12	-68.01	-56.31	1.7	11.89	V	Pass



<b>Band :</b>	GSM1900 for CH 661	<b>Temperature :</b>	23~24°C
<b>Test Mode :</b>	EDGE class 8 Link (8PSK)	<b>Relative Humidity :</b>	46~49%
<b>Test Engineer :</b>	Robin Luo	<b>Polarization :</b>	Horizontal
<b>Remark :</b>	Spurious emissions within 30-1000MHz were found more than 20dB below limit line.		

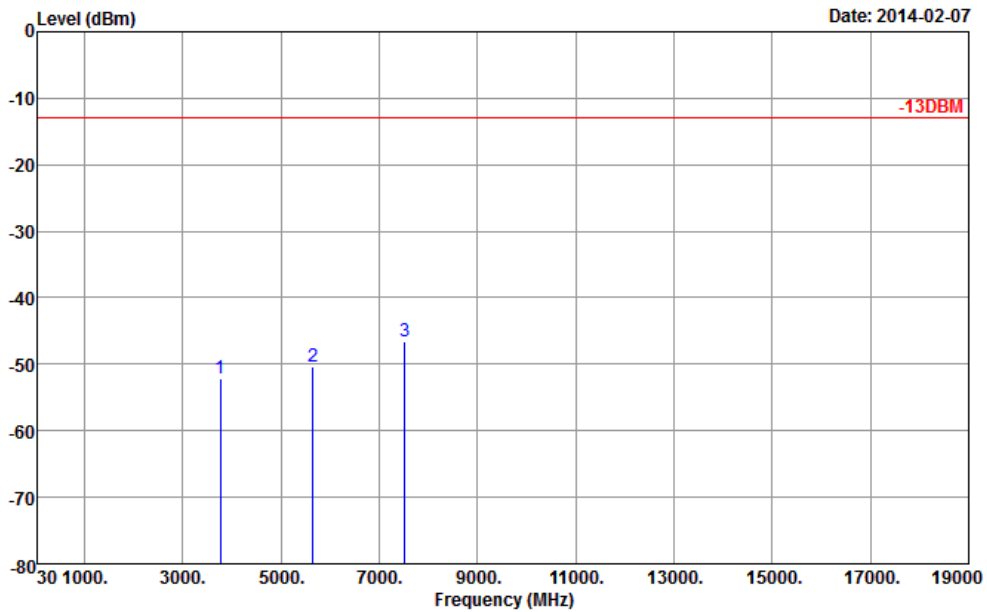

Site : 03CH01-SZ  
 Condition : -13DBM HF\_EIRP\_H\_130101 HORIZONTAL  
 Project : (FG)410803

Frequency ( MHz )	EIRP ( dBm )	Limit ( dBm )	Over Limit ( dB )	SPA Reading ( dBm )	S.G. Power ( dBm )	TX Cable loss ( dB )	TX Antenna Gain ( dBi )	Polarization ( H/V )	Result
3760	-52.22	-13	-39.22	-64.37	-58.96	1.28	8.02	H	Pass
5640	-50.46	-13	-37.46	-68.45	-58.88	1.58	10.00	H	Pass
7520	-46.52	-13	-33.52	-68.46	-56.84	1.78	12.10	H	Pass



<b>Band :</b>	GSM1900 for CH 661	<b>Temperature :</b>	23~24°C
<b>Test Mode :</b>	EDGE class 8 Link (8PSK)	<b>Relative Humidity :</b>	46~49%
<b>Test Engineer :</b>	Robin Luo	<b>Polarization :</b>	Vertical
<b>Remark :</b>	Spurious emissions within 30-1000MHz were found more than 20dB below limit line.		

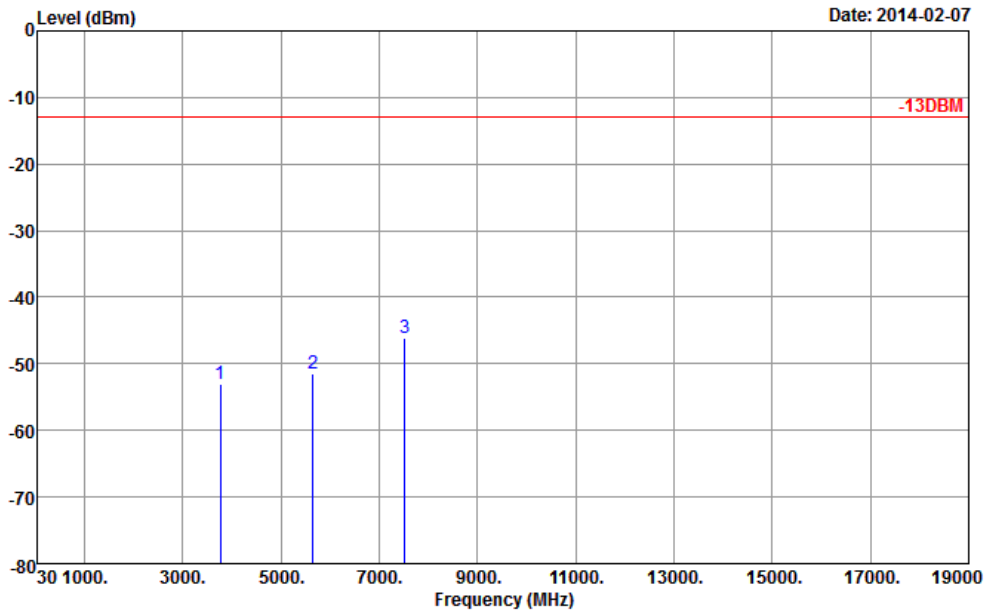

Site : 03CH01-SZ  
 Condition : -13DBM HF\_EIRP\_V\_130101 VERTICAL  
 Project : (FG)410803

Frequency ( MHz )	EIRP ( dBm )	Limit ( dBm )	Over Limit ( dB )	SPA Reading ( dBm )	S.G. Power ( dBm )	TX Cable loss ( dB )	TX Antenna Gain ( dBi )	Polarization ( H/V )	Result
3760	-52.99	-13	-39.99	-68.02	-59.73	1.28	8.02	V	Pass
5640	-51.57	-13	-38.57	-68.65	-59.99	1.58	10	V	Pass
7520	-46.04	-13	-33.04	-68.29	-56.36	1.78	12.1	V	Pass



<b>Band :</b>	GSM1900 for CH 810	<b>Temperature :</b>	23~24°C
<b>Test Mode :</b>	EDGE class 8 Link (8PSK)	<b>Relative Humidity :</b>	46~49%
<b>Test Engineer :</b>	Robin Luo	<b>Polarization :</b>	Horizontal
<b>Remark :</b>	Spurious emissions within 30-1000MHz were found more than 20dB below limit line.		

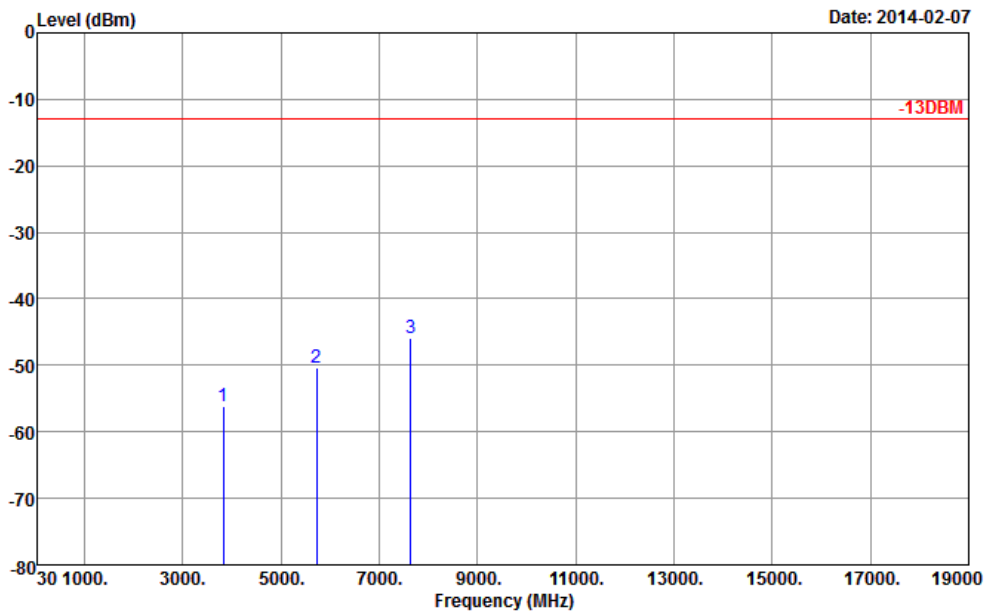

Site : 03CH01-SZ  
 Condition : -13DBM HF\_EIRP\_H\_130101 HORIZONTAL  
 Project : (FG)410803

Frequency ( MHz )	EIRP ( dBm )	Limit ( dBm )	Over Limit ( dB )	SPA Reading ( dBm )	S.G. Power ( dBm )	TX Cable loss ( dB )	TX Antenna Gain ( dBi )	Polarization ( H/V )	Result
3819.6	-56.11	-13	-43.11	-67.68	-62.88	1.23	8.00	H	Pass
5729.4	-50.43	-13	-37.43	-68.23	-58.56	1.52	9.65	H	Pass
7639.2	-45.82	-13	-32.82	-68.06	-56.00	1.82	12.00	H	Pass



<b>Band :</b>	GSM1900 for CH 810	<b>Temperature :</b>	23~24°C
<b>Test Mode :</b>	EDGE class 8 Link (8PSK)	<b>Relative Humidity :</b>	46~49%
<b>Test Engineer :</b>	Robin Luo	<b>Polarization :</b>	Vertical
<b>Remark :</b>	Spurious emissions within 30-1000MHz were found more than 20dB below limit line.		

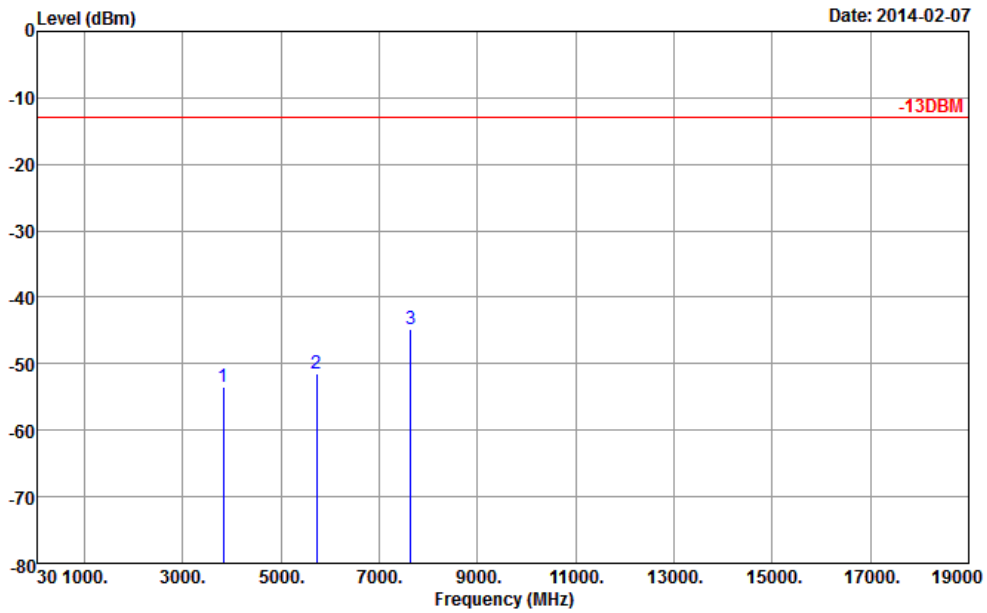

Site : 03CH01-SZ  
 Condition : -13DBM HF\_EIRP\_V\_130101 VERTICAL  
 Project : (FG)410803

Frequency ( MHz )	EIRP ( dBm )	Limit ( dBm )	Over Limit ( dB )	SPA Reading ( dBm )	S.G. Power ( dBm )	TX Cable loss ( dB )	TX Antenna Gain ( dBi )	Polarization ( H/V )	Result
3819.6	-53.41	-13	-40.41	-67.86	-60.18	1.23	8	V	Pass
5729.4	-51.53	-13	-38.53	-68.42	-59.66	1.52	9.65	V	Pass
7639.2	-44.79	-13	-31.79	-67.34	-54.97	1.82	12	V	Pass

## 3.8 Frequency Stability Measurement

### 3.8.1 Description of Frequency Stability Measurement

The frequency stability shall be measured by variation of ambient temperature and variation of primary supply voltage to ensure that the fundamental emission stays within the authorized frequency block. The frequency stability of the transmitter shall be maintained within  $\pm 0.00025\%$  ( $\pm 2.5\text{ppm}$ ) of the center frequency.

### 3.8.2 Measuring Instruments

The measuring equipment is listed in the section 4 of this test report.

### 3.8.3 Test Procedures for Temperature Variation

1. The EUT was set up in the thermal chamber and connected with the base station.
2. With power OFF, the temperature was decreased to  $-30^{\circ}\text{C}$  and the EUT was stabilized before testing. Power was applied and the maximum change in frequency was recorded within one minute.
3. With power OFF, the temperature was raised in  $10^{\circ}\text{C}$  step up to  $50^{\circ}\text{C}$ . The EUT was stabilized at each step for at least half an hour. Power was applied and the maximum frequency change was recorded within one minute.

### 3.8.4 Test Procedures for Voltage Variation

1. The EUT was placed in a temperature chamber at  $25\pm 5^{\circ}\text{C}$  and connected with the base station.
2. The power supply voltage to the EUT was varied from BEP to 115% of the nominal value measured at the input to the EUT.
3. The variation in frequency was measured for the worst case.

### 3.8.5 Test Setup

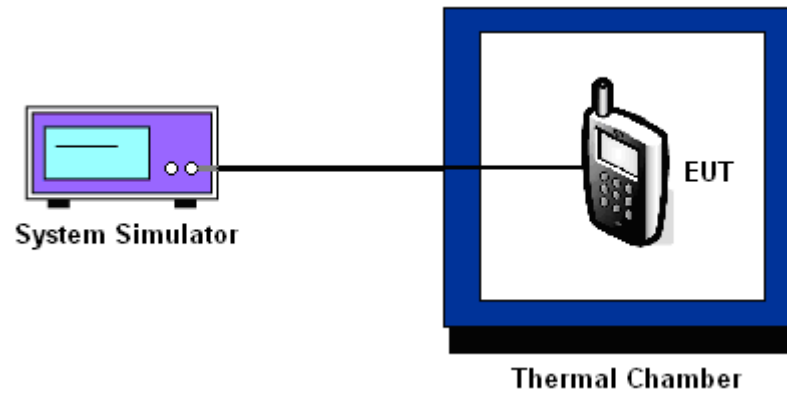



3.8.6 Test Result of Temperature Variation

SIM1 Card:

Band :	GSM 850	Channel :	189
Limit (ppm) :	2.5	Frequency :	836.4 MHz

Temperature (°C)	GSM		EDGE class 8		Result
	Freq. Dev. (Hz)	Deviation (ppm)	Freq. Dev. (Hz)	Deviation (ppm)	
-30	-18	-0.02	9	0.01	PASS
-20	-16	-0.02	9	0.01	
-10	-14	-0.02	-10	-0.01	
0	-15	-0.02	-9	-0.01	
10	-16	-0.02	-10	-0.01	
20	-15	-0.02	-11	-0.01	
30	-18	-0.02	12	0.01	
40	-19	-0.02	-12	-0.01	
50	-22	-0.03	13	0.02	
60	-23	-0.03	15	0.02	

Note: The manufacturer declared that the EUT could work properly at temperature 60°C.

Band :	GSM 1900	Channel :	661
Limit (ppm) :	2.5	Frequency :	1880.0 MHz

Temperature (°C)	GSM		EDGE class 8		Result
	Freq. Dev. (Hz)	Deviation (ppm)	Freq. Dev. (Hz)	Deviation (ppm)	
-30	-24	-0.01	35	0.02	PASS
-20	-23	-0.01	32	0.02	
-10	-27	-0.01	29	0.02	
0	-25	-0.01	-24	-0.01	
10	-28	-0.01	-22	-0.01	
20	-30	-0.02	-26	-0.01	
30	-24	-0.01	-28	-0.01	
40	-26	-0.01	32	0.02	
50	-21	-0.01	36	0.02	
60	-24	-0.01	39	0.02	



<b>Band :</b>	WCDMA Band V	<b>Channel :</b>	4182
<b>Limit (ppm) :</b>	2.5	<b>Frequency :</b>	836.4 MHz

Temperature (°C)	RMC 12.2Kbps		Result
	Freq. Dev. (Hz)	Deviation (ppm)	
-30	-3	0.00	PASS
-20	-3	0.00	
-10	-2	0.00	
0	-3	0.00	
10	-2	0.00	
20	-3	0.00	
30	-3	0.00	
40	-3	0.00	
50	-2	0.00	
60	-3	0.00	

<b>Band :</b>	WCDMA Band II	<b>Channel :</b>	9400
<b>Limit (ppm) :</b>	2.5	<b>Frequency :</b>	1880.0 MHz

Temperature (°C)	RMC 12.2Kbps		Result
	Freq. Dev. (Hz)	Deviation (ppm)	
-30	-11	-0.01	PASS
-20	-11	-0.01	
-10	-10	-0.01	
0	-10	-0.01	
10	-11	-0.01	
20	-11	-0.01	
30	-9	0.00	
40	-11	-0.01	
50	-10	-0.01	
60	-11	-0.01	



SIM2 Card:

Band :	GSM 1900	Channel :	661
Limit (ppm) :	2.5	Frequency :	1880.0 MHz

Temperature (°C)	GSM		EDGE class 8		Result
	Freq. Dev. (Hz)	Deviation (ppm)	Freq. Dev. (Hz)	Deviation (ppm)	
-30	-23	-0.01	-15	-0.01	PASS
-20	-21	-0.01	-13	-0.01	
-10	-22	-0.01	-14	-0.01	
0	-20	-0.01	-12	-0.01	
10	-18	-0.01	-15	-0.01	
20	-21	-0.01	-13	-0.01	
30	-23	-0.01	-14	-0.01	
40	-22	-0.01	-16	-0.01	
50	-23	-0.01	-14	-0.01	
60	-25	-0.01	-17	-0.01	



3.8.7 Test Result of Voltage Variation

SIM1 Card:

Band & Channel	Mode	Voltage (Volt)	Freq. Dev. (Hz)	Deviation (ppm)	Limit (ppm)	Result
GSM 850 CH189	GSM	3.8	-15	-0.02	2.5	PASS
		BEP	-17	-0.02		
		4.35	-16	-0.02		
	EDGE class 8	3.8	-10	-0.01		
		BEP	-10	-0.01		
		4.35	-9	-0.01		
GSM 1900 CH661	GSM	3.8	-30	-0.02		
		BEP	-26	-0.01		
		4.35	-28	-0.01		
	EDGE class 8	3.8	-30	-0.02		
		BEP	-32	-0.02		
		4.35	-33	-0.02		
WCDMA Band V CH4182	RMC 12.2Kbps	3.8	-3	0.00		
		BEP	-3	0.00		
		4.35	-2	0.00		
WCDMA Band II CH9400	RMC 12.2Kbps	3.8	-10	-0.01		
		BEP	-9	0.00		
		4.35	-10	-0.01		

Note:

1. Normal Voltage = 3.8V.
2. Battery End Point (BEP) = 3.4 V.

SIM2 Card:

Band & Channel	Mode	Voltage (Volt)	Freq. Dev. (Hz)	Deviation (ppm)	Limit (ppm)	Result
GSM 1900 CH661	GSM	3.8	-21	-0.01	2.5	PASS
		BEP	-20	-0.01		
		4.35	-22	-0.01		
	EDGE class 8	3.8	-13	-0.01		
		BEP	-15	-0.01		
		4.35	-14	-0.01		

Note:

1. Normal Voltage = 3.8V.
2. Battery End Point (BEP) = 3.4 V.



## 4 List of Measuring Equipment

Instrument	Manufacturer	Model No.	Serial No.	Characteristics	Calibration Date	Test Date	Due Date	Remark
Spectrum Analyzer	R&S	FSP30	101400	9kHz~30GHz	Mar. 28, 2013	Jan. 12, 2014~ Feb. 08, 2014	Mar. 27, 2014	Conducted (TH01-SZ)
Spectrum Analyzer	R&S	FSV30	100845	9kHz~30GHz; Max input Power	Dec. 04, 2013	Jan. 12, 2014~ Feb. 08, 2014	Dec. 03, 2014	Conducted (TH01-SZ)
Power Meter	Anritsu	ML2495A	1218010	13dBm~-20dBm	Mar. 28, 2013	Jan. 12, 2014~ Feb. 08, 2014	Mar. 27, 2014	Conducted (TH01-SZ)
Power Sensor	Anritsu	MA2411B	1207253	0.3GHz~40GHz	Mar. 28, 2013	Jan. 12, 2014~ Feb. 08, 2014	Mar. 27, 2014	Conducted (TH01-SZ)
Thermal Chamber	Hongzhan	LP-150U	HD20120425	-40°C~150°C	Mar. 28, 2013	Jan. 12, 2014~ Feb. 08, 2014	Mar. 27, 2014	Conducted (TH01-SZ)
Spectrum Analyzer	Agilent Technologies	N9038A	MY52260185	20Hz~26.5GHz	Apr. 04, 2013	Jan. 17, 2014~ Feb. 13, 2014	Apr. 03, 2014	Radiation (03CH01-SZ)
Double Ridge Horn Antenna	ETS Lindgren	3117	00119436	1GHz~18GHz	Oct. 26, 2013	Jan. 17, 2014~ Feb. 13, 2014	Oct. 25, 2014	Radiation (03CH01-SZ)
Bilog Antenna	SCHAFFNER	CBL6112B	2614	30MHz~2GHz	Dec. 23, 2013	Jan. 17, 2014~ Feb. 13, 2014	Dec. 22, 2014	Radiation (03CH01-SZ)
Amplifier	ADVANTEST	BB525C	E9007003	9kHz~3000MHz Gain 30db	Mar. 29, 2013	Jan. 17, 2014~ Feb. 13, 2014	Mar. 28, 2014	Radiation (03CH01-SZ)
Amplifier	Yiai	AV3860B	04030	2GHz~26.5GHz	Mar. 29, 2013	Jan. 17, 2014~ Feb. 13, 2014	Mar. 28, 2014	Radiation (03CH01-SZ)
SHF-EHF-Horn Antenna	Schwarzbeck	BBHA9170	BBHA9170249	14GHz~40GHz	Jan. 13, 2014	Jan. 17, 2014~ Feb. 13, 2014	Jan. 12 2015	Radiation (03CH01-SZ)
Turn Table	EM Electronics	EM 1000	N/A	0~360 degree	N/A	Jan. 17, 2014~ Feb. 13, 2014	N/A	Radiation (03CH01-SZ)
Antenna Mast	EM Electronics	EM 1000	N/A	1 m~4 m	N/A	Jan. 17, 2014~ Feb. 13, 2014	N/A	Radiation (03CH01-SZ)



## 5 Uncertainty of Evaluation

### Uncertainty of Radiated Emission Measurement (30 MHz ~ 1000 MHz)

Measuring Uncertainty for a Level of Confidence of 95% ( $U = 2Uc(y)$ )	3.90
---	------