

FCC RF Test Report

APPLICANT : Samsung Electronics Co., Ltd.
EQUIPMENT : Mobile Phone
BRAND NAME : SAMSUNG
MODEL NAME : SCH-P709E
FCC ID : A3LSCHP709E
STANDARD : FCC Part 15 Subpart E §15.407
CLASSIFICATION : (NII) Unlicensed National Information Infrastructure

The product was received on Jan. 08, 2014 and testing was completed on Feb. 12, 2014. SPORTON INTERNATIONAL (SHENZHEN) INC., would like to declare that the tested sample has been evaluated in accordance with the procedures and shown to be compliant with the applicable technical standards.

The test results in this report apply exclusively to the tested model / sample. Without written approval of SPORTON INTERNATIONAL (SHENZHEN) INC., the test report shall not be reproduced except in full.



Reviewed by: Joseph Lin / Supervisor

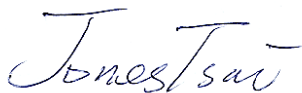

Approved by: Jones Tsai / Manager



SPORTON INTERNATIONAL (SHENZHEN) INC.

No. 3 Building, the third floor of south, Shahe River west, Fengzeyuan warehouse, Nanshan District, Shenzhen, Guangdong, P.R.C.



TABLE OF CONTENTS

REVISION HISTORY.....	3
SUMMARY OF TEST RESULT	4
1 GENERAL DESCRIPTION	5
1.1 Applicant.....	5
1.2 Manufacturer.....	5
1.3 Feature of Equipment Under Test	5
1.4 Product Specification of Equipment Under Test.....	6
1.5 Modification of EUT	6
1.6 Testing Site.....	7
1.7 Applied Standards	7
2 TEST CONFIGURATION OF EQUIPMENT UNDER TEST	8
2.1 Carrier Frequency Channel	9
2.2 Pre-Scanned RF Power.....	10
2.3 Test Mode.....	12
2.4 Connection Diagram of Test System.....	14
2.5 Support Unit used in test configuration and system.....	15
2.6 EUT Operation Test Setup	15
2.7 Measurement Results Explanation Example.....	15
3 TEST RESULT.....	16
3.1 26dB Bandwidth Measurement	16
3.2 Maximum Conducted Output Power Measurement	19
3.3 Power Spectral Density Measurement	23
3.4 Peak Excursion Ratio Measurement	27
3.5 Unwanted Radiated Emission Measurement	29
3.6 AC Conducted Emission Measurement.....	69
3.7 Frequency Stability Measurement.....	75
3.8 Automatically Discontinue Transmission	77
3.9 Antenna Requirements	78
4 LIST OF MEASURING EQUIPMENT	79
5 UNCERTAINTY OF EVALUATION	80

SUMMARY OF TEST RESULT

Report Section	FCC Rule	Description	Limit	Result	Remark
3.1	15.403(i)	26dB & Bandwidth	-	Pass	-
3.2	15.407(a)	Maximum Conducted Output Power	≤ 17, 24, 30 dBm (depend on band)	Pass	-
3.3	15.407(a)	Power Spectral Density	≤ 4, 11, 17 dBm (depend on band)	Pass	-
3.4	15.407(a)(6)	Peak Excursion Ratio	≤ 13dB	Pass	-
3.5	15.407(b)	Unwanted Emissions	≤ -17, -27 dBm (depend on band)&15.209(a)	Pass	Under limit 3.31 dB at 5350.330 MHz
3.6	15.207	AC Conducted Emission	15.207(a)	Pass	Under limit 5.66 dB at 13.620 MHz
3.7	15.407(g)	Frequency Stability	Within Operation Band	Pass	-
3.8	15.407(c)	Automatically Discontinue Transmission	Discontinue Transmission	Pass	-
3.9	15.203 & 15.407(a)	Antenna Requirement	N/A	Pass	-



1 General Description

1.1 Applicant

Samsung Electronics Co., Ltd.

A3 Building, No.185 Kexue Avenue, Science City, Guang Zhou, PRC

1.2 Manufacturer

Samsung Electronics Co., Ltd.

129, Samsung-ro, Yeongtong-gu, Suwon-city, Gyeonggi-do, 443-742, Korea

1.3 Feature of Equipment Under Test

Product Feature	
Equipment	Mobile Phone
Brand Name	SAMSUNG
Model Name	SCH-P709E
FCC ID	A3LSCHP709E
GSM Operating Band(s)	GSM 850/900/1800/1900MHz
GPRS / EGPRS Multi Slot Class	GPRS Class 10 , EGPRS Class 10
WCDMA Operating Band(s)	FDDI/FDDII/FDDV
Wi-Fi Specification	802.11b/g/n (HT20) 802.11a/n (HT20/HT40)
Bluetooth Version	Bluetooth v3.0+EDR, Bluetooth v4.0 LE
NFC Specification	Type A/B
HW Version	P709E.03
SW Version	P709EKEUAMK1
EUT Stage	Pre-Production

Remark: The above EUT's information was declared by manufacturer. Please refer to the specifications or user's manual for more detailed description.

1.4 Product Specification of Equipment Under Test

Product Specification subjective to this standard	
Tx/Rx Frequency Range	5180 MHz ~ 5240 MHz 5260 MHz ~ 5320 MHz 5500 MHz ~ 5580 MHz 5660 MHz ~ 5700 MHz
Maximum Output Power to Antenna	<5180 MHz ~ 5240 MHz> 802.11a : 13.60 dBm / 0.0229 W 802.11n HT20 : 11.97 dBm / 0.0157 W 802.11n HT40 : 14.16 dBm / 0.0261 W <5260 MHz ~ 5320 MHz> 802.11a : 13.02 dBm / 0.0200 W 802.11n HT20 : 11.35 dBm / 0.0136 W 802.11n HT40 : 14.00 dBm / 0.0251 W <5500 MHz ~ 5580 MHz and 5660 MHz ~ 5700 MHz > 802.11a : 14.57 dBm / 0.0286 W 802.11n HT20 : 12.86 dBm / 0.0193 W 802.11n HT40 : 14.75 dBm / 0.0299 W
Antenna Type	<5180 MHz ~ 5240 MHz> Antenna : FPCB Antenna with gain 1.40 dBi <5260 MHz ~ 5320 MHz> Antenna : FPCB Antenna with gain 1.40 dBi <5500 MHz ~ 5580 MHz & 5660 MHz ~ 5700 MHz > Antenna : FPCB Antenna with gain -0.70 dBi
Type of Modulation	OFDM (BPSK / QPSK / 16QAM / 64QAM)

1.5 Modification of EUT

No modifications are made to the EUT during all test items.

1.6 Testing Site

Test Site	SPORTON INTERNATIONAL (SHENZHEN) INC.			
Test Site Location	No. 3 Building, the third floor of south, Shahe River west, Fengzeyuan warehouse, Nanshan District, Shenzhen, Guangdong, P.R.C. TEL: +86-755- 3320-2398			
Test Site No.	Sporton Site No.			FCC Registration No.
	TH01-SZ	CO01-SZ	03CH01-SZ	831040

Note: The test site complies with ANSI C63.4 2003 requirement.

1.7 Applied Standards

According to the specifications of the manufacturer, the EUT must comply with the requirements of the following standards:

- FCC Part 15 Subpart E
- FCC KDB 789033 D01 General UNII Test Procedures v01r03
- ANSI C63.4-2003

Remark:

1. All test items were verified and recorded according to the standards and without any deviation during the test.
2. This EUT has also been tested and complied with the requirements of FCC Part 15, Subpart B, recorded in a separate test report.



2 Test Configuration of Equipment Under Test

The EUT has been associated with peripherals and configuration operated in a manner tended to maximize its emission characteristics in a typical application. Frequency range investigated: conducted emission (150 kHz to 30 MHz) and radiated emission (9 kHz to the 10th harmonic of the highest fundamental frequency or to 40 GHz, whichever is lower). For radiated measurement, pre-scanned in three orthogonal panels, X, Y, Z. The worst cases (X plane) were recorded in this report.

The final configuration from all the combinations and the worst-case data rates were investigated by measuring the maximum power across all the data rates and modulation modes under section 2.2.

Based on the worst configuration found above, the RF power setting is set individually to meet FCC compliance limit for the final conducted and radiated tests shown in section 2.3.

2.1 Carrier Frequency Channel

Frequency Band	Channel	Freq. (MHz)	Channel	Freq. (MHz)
5150-5250 MHz Band 1 (U-NII-1)	36	5180	44	5220
	38	5190	46	5230
	40	5200	48	5240

Frequency Band	Channel	Freq. (MHz)	Channel	Freq. (MHz)
5250-5350 MHz Band 2 (U-NII-2A)	52	5260	60	5300
	54	5270	62	5310
	56	5280	64	5320

Frequency Band	Channel	Freq. (MHz)	Channel	Freq. (MHz)
5470-5600 MHz and 5650-5725 MHz Band 3 (U-NII-2C)	100	5500	116	5580
	102	5510	132	5660
	104	5520	134	5670
	108	5540	136	5680
	110	5550	140	5700
	112	5560		

Note: The above Frequency and Channel in boldface were 802.11n HT40.

2.2 Pre-Scanned RF Power

Preliminary tests were performed in different data rate and data rate associated with the highest power were chosen for full test in the following tables. Final Output Power equals to Measured Output Power adds the duty factor.

Channel	Frequency	5GHz 802.11a RF Power (dBm)							
		OFDM Data Rate							
		6M bps	9M bps	12M bps	18M bps	24M bps	36M bps	48M bps	54M bps
CH 36	5180 MHz	13.23	13.15	13.16	13.17	13.15	13.21	13.20	13.21
CH 44	5220 MHz	13.60	13.52	13.53	13.54	13.52	13.58	13.57	13.58
CH 48	5240 MHz	12.94	12.86	12.87	12.88	12.86	12.92	12.91	12.92
CH 52	5260 MHz	12.42	12.34	12.35	12.36	12.34	12.40	12.39	12.40
CH 60	5300 MHz	13.02	12.94	12.95	12.96	12.94	13.00	12.99	13.00
CH 64	5320 MHz	12.83	12.75	12.76	12.77	12.75	12.81	12.80	12.81
CH 100	5500 MHz	13.51	13.43	13.44	13.45	13.43	13.49	13.48	13.49
CH 116	5580 MHz	14.20	14.12	14.13	14.14	14.12	14.18	14.17	14.18
CH 140	5700 MHz	14.57	14.49	14.50	14.51	14.49	14.55	14.54	14.55

Channel	Frequency	5GHz 802.11a/n HT20 RF Power (dBm)							
		OFDM Data Rate							
		MCS0	MCS1	MCS2	MCS3	MCS4	MCS5	MCS6	MCS7
CH 36	5180 MHz	11.60	11.52	11.56	11.53	11.55	11.55	11.57	11.58
CH 44	5220 MHz	11.97	11.89	11.93	11.90	11.92	11.92	11.94	11.95
CH 48	5240 MHz	11.31	11.23	11.27	11.24	11.26	11.26	11.28	11.29
CH 52	5260 MHz	10.67	10.59	10.63	10.60	10.62	10.62	10.64	10.65
CH 60	5300 MHz	11.35	11.27	11.31	11.28	11.30	11.30	11.32	11.33
CH 64	5320 MHz	11.09	11.01	11.05	11.02	11.04	11.04	11.06	11.07
CH 100	5500 MHz	12.79	12.71	12.75	12.72	12.74	12.74	12.76	12.77
CH 116	5580 MHz	12.75	12.67	12.71	12.68	12.70	12.70	12.72	12.73
CH 140	5700 MHz	12.86	12.78	12.82	12.79	12.81	12.81	12.83	12.84



Channel	Frequency	5GHz 802.11a/n HT40 RF Power (dBm)							
		OFDM Data Rate							
		MCS0	MCS1	MCS2	MCS3	MCS4	MCS5	MCS6	MCS7
CH 38	5190 MHz	14.16	14.14	14.12	14.09	14.10	14.12	14.10	14.13
CH 46	5230 MHz	14.02	14.00	13.98	13.95	13.96	13.98	13.96	13.99
CH 54	5270 MHz	13.70	13.68	13.66	13.63	13.64	13.66	13.64	13.67
CH 62	5310 MHz	14.00	13.98	13.96	13.93	13.94	13.96	13.94	13.97
CH 102	5510 MHz	13.58	13.56	13.54	13.51	13.52	13.54	13.52	13.55
CH 110	5550 MHz	13.80	13.78	13.76	13.73	13.74	13.76	13.74	13.77
CH 134	5670 MHz	14.75	14.73	14.71	14.68	14.69	14.71	14.69	14.72

2.3 Test Mode

Final results of test modes, data rates and test channels are shown as following table.

Test Cases				
	Test Items	Mode	Data rate	Test Channel
Conducted TCs	26dB and Power Spectral Density	802.11a	6 Mbps	L/M/H
		802.11n HT20	MCS0	L/M/H
		802.11n HT40	MCS0	L/M/H
	Output Power	802.11a	6 Mbps	L/M/H
		802.11n HT20	MCS0	L/M/H
		802.11n HT40	MCS0	L/M/H
	Peak Excursion	802.11a	6 Mbps	L
		802.11n HT20	MCS0	L
		802.11n HT40	MCS0	L
	Frequency Stability	802.11a	6 Mbps	L/H
Radiated TCs	Radiated Band Edge	802.11a	6 Mbps	L/H
		802.11n HT20	MCS0	L/H
		802.11n HT40	MCS0	L/H
	Radiated Spurious Emission	802.11a	6 Mbps	L/M/H
		802.11n HT20	MCS0	L/M/H
		802.11n HT40	MCS0	L/M/H
AC Conducted Emission	Mode 1 : GSM1900 Idle + Bluetooth Link + WLAN (5GHz) Link + Eaphone + NFC On + USB Cable (Charging from Adapter) + SIM 2			



Ch. #		Band I : 5150-5250 MHz	Band II : 5250-5350 MHz	Band III : 5470-5600 MHz and 5650-5725MHz
		802.11a	802.11a	802.11a
L	Low	36	52	100
M	Middle	44	60	116
H	High	48	64	140

Ch. #		Band I : 5150-5250 MHz	Band II : 5250-5350 MHz	Band III : 5470-5600 MHz and 5650-5725MHz
		802.11n HT20	802.11n HT20	802.11n HT20
L	Low	36	52	100
M	Middle	44	60	116
H	High	48	64	140

Ch. #		Band I : 5150-5250 MHz	Band II : 5250-5350 MHz	Band III : 5470-5600 MHz and 5650-5725MHz
		802.11n HT40	802.11n HT40	802.11n HT40
L	Low	38	54	102
M	Middle	-	-	110
H	High	46	62	134

2.4 Connection Diagram of Test System

<WLAN Tx Mode>

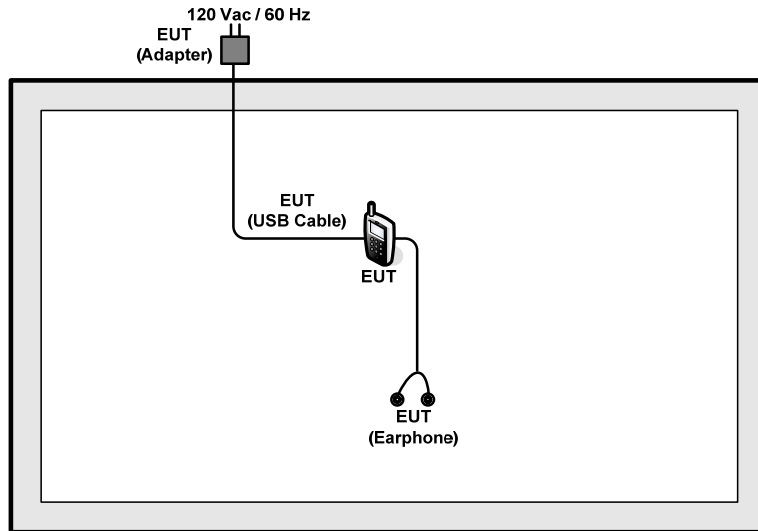

<AC Conducted Emission Mode>

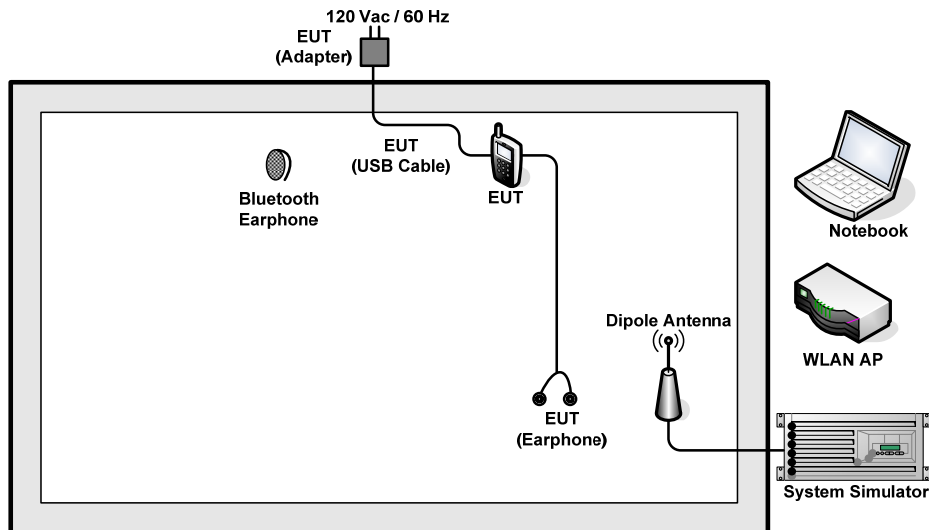

2.5 Support Unit used in test configuration and system

Item	Equipment	Trade Name	Model Name	FCC ID	Data Cable	Power Cord
1.	System Simulator	R&S	CMW 500	N/A	N/A	Unshielded, 1.8 m
2.	WLAN AP	D-Link	DIR-815	KA2DIR815A1	N/A	Unshielded, 1.8 m
3.	Notebook	DELL	Vostro 2420	FCC DoC	N/A	AC I/P: Unshielded, 1.2 m DC O/P: Shielded, 1.8 m
4.	Bluetooth Earphone	Nokia	BH-108	PYAHS-107W	N/A	N/A

2.6 EUT Operation Test Setup

For WLAN RF test items, an engineering test program was provided and enabled to make EUT continuous transmit/receive.

2.7 Measurement Results Explanation Example

For all conducted test items:

The offset level is set in the spectrum analyzer to compensate the RF cable loss and attenuator factor between EUT conducted output port and spectrum analyzer. With the offset compensation, the spectrum analyzer reading level is exactly the EUT RF output level.

Example :

The spectrum analyzer offset is derived from RF cable loss and attenuator factor.

Offset = RF cable loss + attenuator factor.

Following shows an offset computation example with cable loss 4.2 dB and 10dB attenuator.

$$\begin{aligned}
 \text{Offset(dB)} &= \text{RF cable loss(dB)} + \text{attenuator factor(dB)}. \\
 &= 4.2 + 10 = 14.2 \text{ (dB)}
 \end{aligned}$$

3 Test Result

3.1 26dB Bandwidth Measurement

3.1.1 Description of 26dB Bandwidth

There is no restriction limits for bandwidth. The maximum conducted output power can be limited by measured emission bandwidth (B).

For the band 5150-5250 MHz, the maximum conducted output power over the frequency band of operation shall not exceed the lesser of 50 mW (17dBm) or 4 dBm + 10log B.

For the bands 5250-5350 MHz and 5470-5600 MHz and 5650-5725MHz, the maximum conducted output power over the frequency bands of operation shall not exceed the lesser of 250 mW (24dBm) or 11 dBm + 10log B.

3.1.2 Measuring Instruments

The measuring equipment is listed in the section 4 of this test report.

3.1.3 Test Procedures

1. The testing follows FCC KDB 789033 D01 General UNII Test Procedures v01r03.
Section D) Emission bandwidth
2. Set RBW = approximately 1% of the emission bandwidth.
3. Set the VBW > RBW.
4. Detector = Peak.
5. Trace mode = max hold
6. Measure the maximum width of the emission that is 26 dB down from the peak of the emission.
Compare this with the RBW setting of the analyzer. Readjust RBW and repeat measurement as needed until the RBW/EBW ratio is approximately 1%.
7. Measure and record the results in the test report.

3.1.4 Test Setup

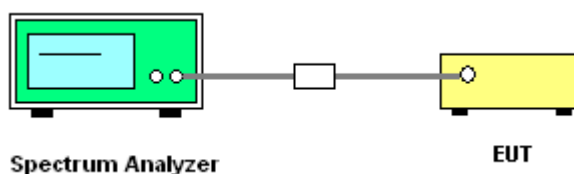



3.1.5 Test Result of 26dB Bandwidth Plots

Test Band :	5GHz band 1	Temperature :	24~26°C
Test Engineer :	Blithe Li	Relative Humidity :	50~53%

Mod.	Data Rate	N _{TX}	Channel	Freq. (MHz)	26dB Bandwidth (MHz)	FCC 26dB Bandwidth Power Limit (dBm)
11a	6Mbps	1	36	5180	28.65	16.99
11a	6Mbps	1	44	5220	27.30	16.99
11a	6Mbps	1	48	5240	26.05	16.99
HT20	MCS0	1	36	5180	23.75	16.99
HT20	MCS0	1	44	5220	24.20	16.99
HT20	MCS0	1	48	5240	23.60	16.99
HT40	MCS0	1	38	5190	63.09	16.99
HT40	MCS0	1	46	5230	60.57	16.99

Test Band :	5GHz band 2	Temperature :	24~26°C
Test Engineer :	Blithe Li	Relative Humidity :	50~53%

Mod.	Data Rate	N _{TX}	Channel	Freq. (MHz)	26dB Bandwidth (MHz)	FCC 26dB Bandwidth Power Limit (dBm)
11a	6Mbps	1	52	5260	24.90	23.98
11a	6Mbps	1	60	5300	26.10	23.98
11a	6Mbps	1	64	5320	26.30	23.98
HT20	MCS0	1	52	5260	23.00	23.98
HT20	MCS0	1	60	5300	23.05	23.98
HT20	MCS0	1	64	5320	22.85	23.98
HT40	MCS0	1	54	5270	55.98	23.98
HT40	MCS0	1	62	5310	70.38	23.98



Test Band :	5GHz band 3	Temperature :	24~26°C
Test Engineer :	Blithe Li	Relative Humidity :	50~53%

Mod.	Data Rate	N _{Tx}	Channel	Freq. (MHz)	26dB Bandwidth (MHz)	FCC 26dB Bandwidth Power Limit (dBm)
11a	6Mbps	1	100	5500	30.70	23.98
11a	6Mbps	1	116	5580	31.20	23.98
11a	6Mbps	1	140	5700	30.10	23.98
HT20	MCS0	1	100	5500	26.95	23.98
HT20	MCS0	1	116	5580	26.90	23.98
HT20	MCS0	1	140	5700	23.75	23.98
HT40	MCS0	1	102	5510	61.83	23.98
HT40	MCS0	1	110	5550	55.80	23.98
HT40	MCS0	1	134	5670	64.08	23.98

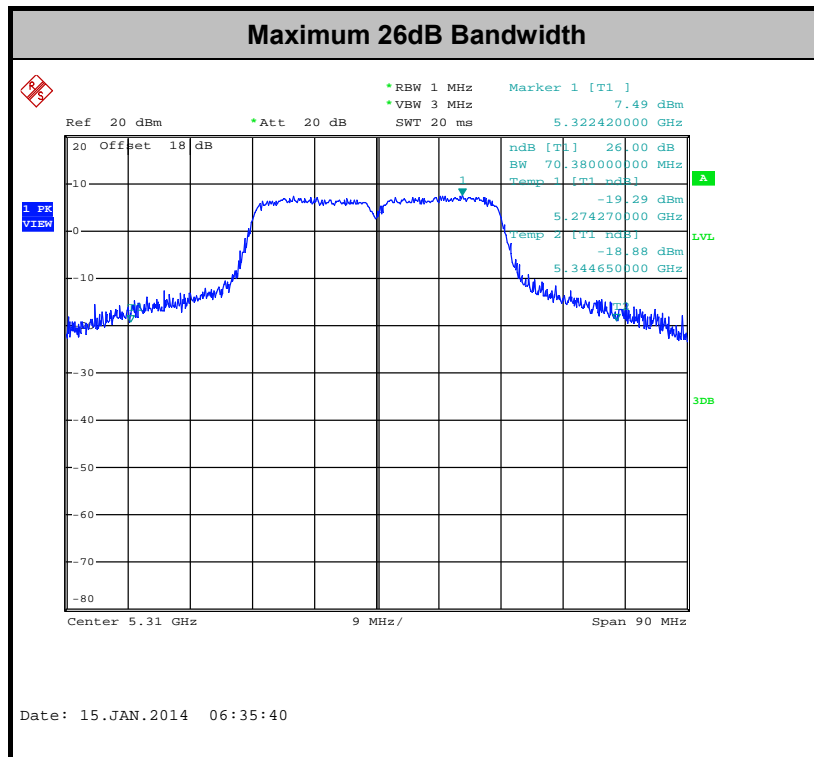

3.2 Maximum Conducted Output Power Measurement

3.2.1 Limit of Maximum Conducted Output Power

For the band 5150-5250 MHz, the maximum conducted output power shall not exceed the lesser of 50 mW (17dBm) or $4 \text{ dBm} + 10\log B$, where B is the 26 dB emissions bandwidth in 1-MHz. If transmitting antenna directional gain is greater than 6 dBi, the peak output power shall be reduced by the amount in dB that the directional gain of the antenna exceeds 6 dBi.

For the bands 5250-5350 MHz and 5470-5600 MHz and 5650-5725 MHz, bands, the maximum conducted output power shall not exceed the lesser of 250 mW (24dBm) or $11 \text{ dBm} + 10\log B$, where B is the 26 dB emissions bandwidth in 1-MHz. If transmitting antenna directional gain is greater than 6 dBi, the peak output power shall be reduced by the amount in dB that the directional gain of the antenna exceeds 6 dBi.

If transmitting antennas of directional gain greater than 6 dBi are used, the peak output power shall be reduced by the amount in dB that the directional gain of the antenna exceeds 6 dBi.

3.2.2 Measuring Instruments

The measuring equipment is listed in the section 4 of this test report.

3.2.3 Test Procedures

The testing follows Method PM of FCC KDB 789033 D01 General UNII Test Procedures v01r03.

Method PM (Measurement using an RF average power meter):

1. Measurement is performed using a wideband RF power meter.
2. The EUT is configured to transmit continuously with a consistent duty cycle at its maximum power control level.
3. Measure the average power of the transmitter, and the average power is corrected with duty factor, $10 \log(1/x)$, where x is the duty cycle.

3.2.4 Test Setup

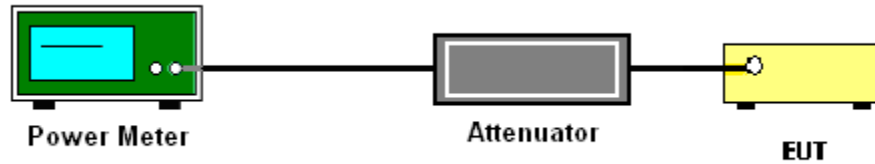

3.2.5 Test Result of Maximum Conducted Output Power

Test Band :	5GHz band 1	Temperature :	24~26°C
Test Engineer :	Blithe Li	Relative Humidity :	50~53%

Mod.	Data Rate	N _{TX}	Channel	Freq. (MHz)	Duty Factor (dB)	Average Conducted Power (dBm)	FCC Conducted Power Limit (dBm)	DG (dBi)	-	Pass/Fail
11a	6Mbps	1	36	5180	0.29	13.23	16.99	1.40	-	Pass
11a	6Mbps	1	44	5220	0.29	13.60	16.99	1.40		Pass
11a	6Mbps	1	48	5240	0.29	12.94	16.99	1.40		Pass
HT20	MCS0	1	36	5180	0.32	11.60	16.99	1.40		Pass
HT20	MCS0	1	44	5220	0.32	11.97	16.99	1.40		Pass
HT20	MCS0	1	48	5240	0.32	11.31	16.99	1.40		Pass
HT40	MCS0	1	38	5190	0.63	14.16	16.99	1.40		Pass
HT40	MCS0	1	46	5230	0.63	14.02	16.99	1.40		Pass

Note:

1. Final Output Power equals to Measured Output Power adds the duty factor.
2. For the band 5150-5250 MHz, the maximum average conducted output power shall not exceed lesser of 50 mW (17dBm) or 4 dBm + 10log (B), where B is 26dB BW for FCC.



Test Band :	5GHz band 2	Temperature :	24~26°C
Test Engineer :	Blithe Li	Relative Humidity :	50~53%

Mod.	Data Rate	N _{TX}	Channel	Freq. (MHz)	Duty Factor (dB)	Average Conducted Power (dBm)	FCC Conducted Power Limit (dBm)	DG (dBi)	-	Pass/Fail
11a	6Mbps	1	52	5260	0.29	12.42	23.98	1.40	-	Pass
11a	6Mbps	1	60	5300	0.29	13.02	23.98	1.40		Pass
11a	6Mbps	1	64	5320	0.29	12.83	23.98	1.40		Pass
HT20	MCS0	1	52	5260	0.32	10.67	23.98	1.40		Pass
HT20	MCS0	1	60	5300	0.32	11.35	23.98	1.40		Pass
HT20	MCS0	1	64	5320	0.32	11.09	23.98	1.40		Pass
HT40	MCS0	1	54	5270	0.63	13.70	23.98	1.40		Pass
HT40	MCS0	1	62	5310	0.63	14.00	23.98	1.40		Pass

Note:

1. Final Output Power equals to Measured Output Power adds the duty factor.
2. For the 5250-5350 MHz bands, the maximum conducted output power shall not exceed the lesser of 250 mW (24dBm) or 11 dBm + 10log (B), where B is 26dB BW for FCC.



Test Band :	5GHz band 3	Temperature :	24~26°C
Test Engineer :	Blithe Li	Relative Humidity :	50~53%

Mod.	Data Rate	N _{TX}	Channel	Freq. (MHz)	Duty Factor (dB)	Average Conducted Power (dBm)	FCC Conducted Power Limit (dBm)	DG (dBi)	-	Pass/Fail
11a	6Mbps	1	100	5500	0.29	13.51	23.98	-0.7	-	Pass
11a	6Mbps	1	116	5580	0.29	14.20	23.98	-0.7		Pass
11a	6Mbps	1	140	5700	0.29	14.57	23.98	-0.7		Pass
HT20	MCS0	1	100	5500	0.32	12.79	23.98	-0.7		Pass
HT20	MCS0	1	116	5580	0.32	12.75	23.98	-0.7		Pass
HT20	MCS0	1	140	5700	0.32	12.86	23.98	-0.7		Pass
HT40	MCS0	1	102	5510	0.63	13.58	23.98	-0.7		Pass
HT40	MCS0	1	110	5550	0.63	13.80	23.98	-0.7		Pass
HT40	MCS0	1	134	5670	0.63	14.75	23.98	-0.7		Pass

Note:

1. Final Output Power equals to Measured Output Power adds the duty factor.
2. For the 5470-5600 MHz and 5650-5725 MHz bands, the maximum conducted output power shall not exceed the lesser of 250 mW (24dBm) or 11 dBm + 10log (B), where B is 26dB BW for FCC.



3.3 Power Spectral Density Measurement

3.3.1 Limit of Power Spectral Density

For the band 5150-5250 MHz, the peak power spectral density shall not exceed 4 dBm in any 1-MHz band.

For the bands 5250-5350 MHz and 5470-5600 and 5650-5725 MHz, the peak power spectral density shall not exceed 11 dBm in any 1-MHz band.

If transmitting antenna directional gain is greater than 6 dBi, both the maximum conducted output power and the peak power spectral density shall be reduced by the amount in dB that the directional gain of the antenna exceeds 6 dBi.

3.3.2 Measuring Instruments

The measuring equipment is listed in the section 4 of this test report.

3.3.3 Test Procedures

The testing follows FCC KDB 789033 D01 General UNII Test Procedures v01r03.

Section F) Peak power spectral density (PPSD).

Note: Though the rule refers to “peak power spectral density”, the intent is to measure the maximum value of the time average of the power spectral density measured during a period of continuous transmission.

Method SA-2

(trace averaging across on and off times of the EUT transmissions, followed by duty cycle correction).

1. The testing follows Method SA-2 of FCC KDB 789033 D01 General UNII Test Procedures v01r03.
 - Measure the duty cycle.
 - Set span to encompass the entire emission bandwidth (EBW) of the signal.
 - Set RBW = 1 MHz.
 - Set VBW \geq 3 MHz.
 - Number of points in sweep \geq 2 Span / RBW.
 - Sweep time = auto.
 - Detector = RMS
 - Trace average at least 100 traces in power averaging mode.
 - Add $10 \log(1/x)$, where x is the duty cycle, to the measured power in order to compute the average power during the actual transmission times. For example, add $10 \log(1/0.25) = 6$ dB if the duty cycle is 25 percent.
2. The RF output of EUT was connected to the spectrum analyzer by a low loss cable.
3. Each plot has already offset with cable loss, and attenuator loss. Measure the PPSD and record it.

3.3.4 Test Setup

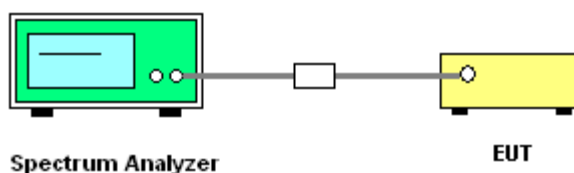



3.3.5 Test Result of Power Spectral Density

Test Band :	5GHz band 1	Temperature :	24~26°C
Test Engineer :	Blithe Li	Relative Humidity :	50~53%

Mod.	Data Rate	N _{TX}	CH	Freq. (MHz)	Duty Factor (dB)	Average Power Density (dBm/MHz)	Average PSD Limit (dBm)	DG (dBi)	Pass/Fail
11a	6Mbps	1	36	5180	0.29	2.91	4.00	1.40	Pass
11a	6Mbps	1	44	5220	0.29	1.72	4.00	1.40	Pass
11a	6Mbps	1	48	5240	0.29	2.53	4.00	1.40	Pass
HT20	MCS0	1	36	5180	0.32	0.77	4.00	1.40	Pass
HT20	MCS0	1	44	5220	0.32	-0.22	4.00	1.40	Pass
HT20	MCS0	1	48	5240	0.32	0.46	4.00	1.40	Pass
HT40	MCS0	1	38	5190	0.63	0.13	4.00	1.40	Pass
HT40	MCS0	1	46	5230	0.63	-0.22	4.00	1.40	Pass

Test Band :	5GHz band 2	Temperature :	24~26°C
Test Engineer :	Blithe Li	Relative Humidity :	50~53%

Mod.	Data Rate	N _{TX}	CH	Freq. (MHz)	Duty Factor (dB)	Average Power Density (dBm/MHz)	Average PSD Limit (dBm)	DG (dBi)	Pass/Fail
11a	6Mbps	1	52	5260	0.29	2.18	11.00	1.40	Pass
11a	6Mbps	1	60	5300	0.29	0.44	11.00	1.40	Pass
11a	6Mbps	1	64	5320	0.29	0.80	11.00	1.40	Pass
HT20	MCS0	1	52	5260	0.32	0.17	11.00	1.40	Pass
HT20	MCS0	1	60	5300	0.32	-1.47	11.00	1.40	Pass
HT20	MCS0	1	64	5320	0.32	-1.08	11.00	1.40	Pass
HT40	MCS0	1	54	5270	0.63	0.21	11.00	1.40	Pass
HT40	MCS0	1	62	5310	0.63	-1.53	11.00	1.40	Pass



Test Band :	5GHz band 3	Temperature :	24~26°C
Test Engineer :	Blithe Li	Relative Humidity :	50~53%

Mod.	Data Rate	N _{TX}	CH	Freq. (MHz)	Duty Factor (dB)	Average Power Density (dBm/MHz)	Average PSD Limit (dBm)	DG (dBi)	Pass/Fail
11a	6Mbps	1	100	5500	0.29	1.16	11.00	-0.7	Pass
11a	6Mbps	1	116	5580	0.29	3.29	11.00	-0.7	Pass
11a	6Mbps	1	140	5700	0.29	2.44	11.00	-0.7	Pass
HT20	MCS0	1	100	5500	0.32	0.26	11.00	-0.7	Pass
HT20	MCS0	1	116	5580	0.32	1.48	11.00	-0.7	Pass
HT20	MCS0	1	140	5700	0.32	0.57	11.00	-0.7	Pass
HT40	MCS0	1	102	5510	0.63	-1.42	11.00	-0.7	Pass
HT40	MCS0	1	110	5550	0.63	0.20	11.00	-0.7	Pass
HT40	MCS0	1	134	5670	0.63	1.28	11.00	-0.7	Pass

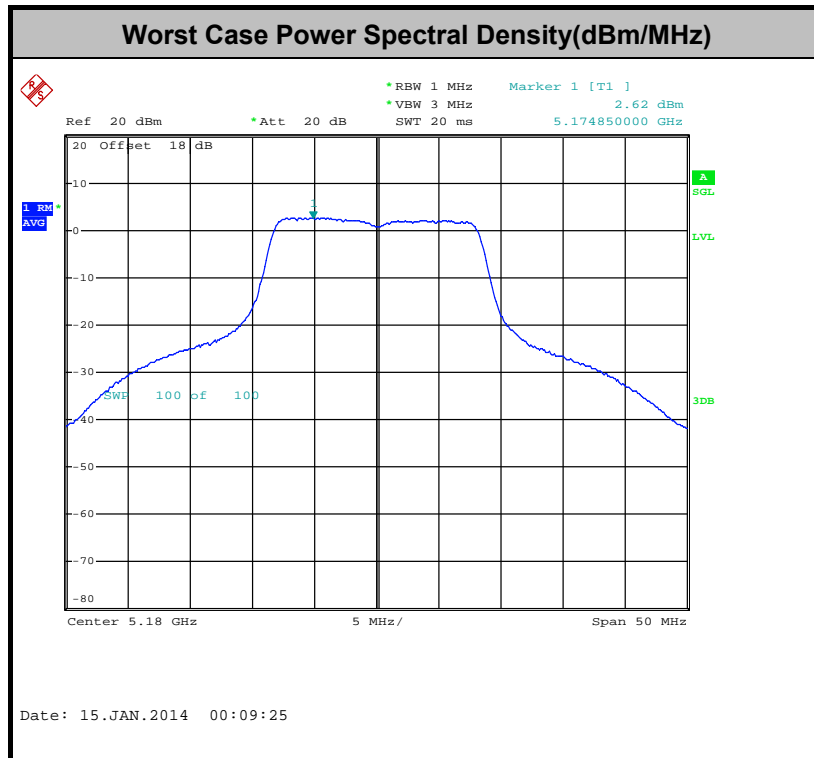

Note: Average Power Density (dB) = Measured value+ Duty Factor

3.4 Peak Excursion Ratio Measurement

3.4.1 Limit of Peak Excursion Ratio

The ratio of the peak excursion of the modulation envelope (measured using a peak hold function) to the maximum conducted output power (measured as specified above) shall not exceed 13 dB across any 1 MHz bandwidth or the emission bandwidth whichever is less.

3.4.2 Measuring Instruments

The measuring equipment is listed in the section 4 of this test report.

3.4.3 Test Procedures

The testing follows FCC KDB 789033 D01 General UNII Test Procedures v01r03.

Section G) Peak excursion measurement

1. The transmitter output is connected to the spectrum analyzer.
2. Set the spectrum analyzer span to view the entire emission bandwidth.
3. Find the maximum of the peak-max-hold spectrum.
 - *Set RBW = 1MHz.
 - *Set VBW \geq 3MHz.
 - *Detector = peak.
 - *Trace mode = max-hold.
 - *Allow the sweeps to continue until the trace stabilizes.
 - *Use the peak search function to find the peak of the spectrum.
4. Use the procedure found under section 3.3 to measure the PPSD.
5. Compute the ratio of the maximum of the peak-max-hold spectrum to the PPSD.

3.4.4 Test Setup

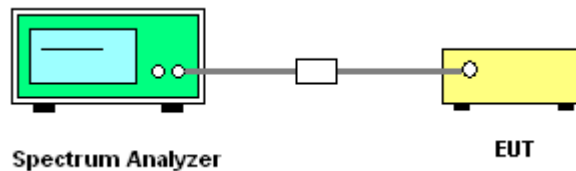

3.4.5 Test Result of Peak Excursion Ratio

Test Band :	5GHz band 3	Temperature :	24~26°C
Test Engineer :	Blithe Li	Relative Humidity :	50~53%

Mod.	N _{TX}	Channel	Freq. (MHz)	Peak Excursion Ratio (dB)					Max. Limits (dB)	Pass/Fail
				BPSK	QPSK	16QAM	64QAM	256QAM		
11a	1	100	5500	9.15	9.17	9.48	9.48	-	13	Pass
HT20	1	100	5500	9.27	9.40	9.29	9.10	-	13	Pass
HT40	1	102	5510	9.10	9.52	9.78	9.71	-	13	Pass

Note: All modulation measured based on the minimum data rate setting.

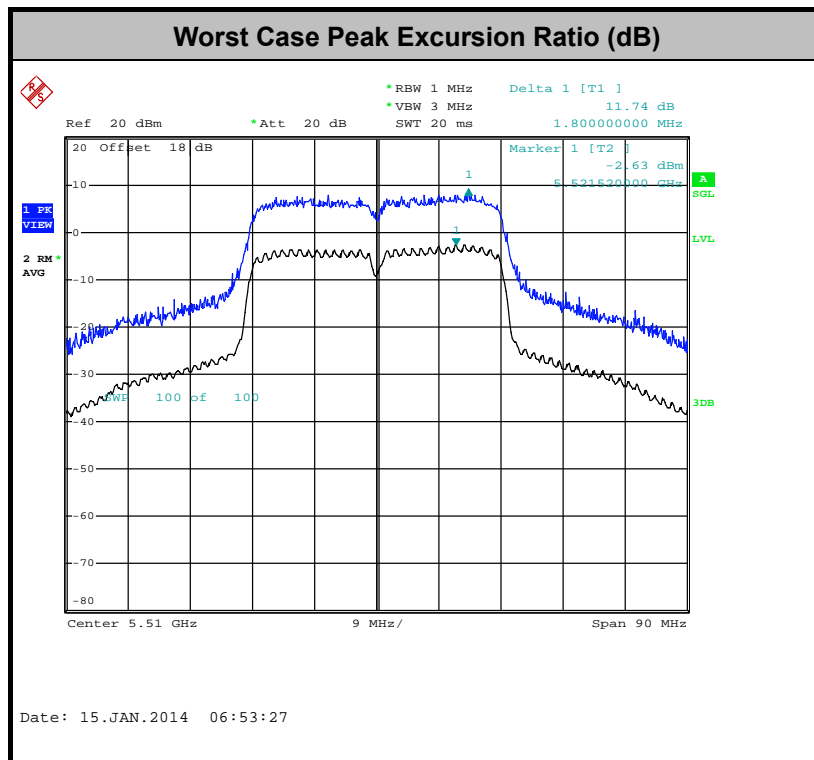

Note: Peak Excursion Ratio (dB) = Peak – (Average + Duty Cycle Offset)
 Duty Cycle Offset: 1.96 dB

3.5 Unwanted Radiated Emission Measurement

This section as specified in FCC Part 15.407(b) is to measure unwanted emissions through radiated measurement for band edge spurious emissions and out of band emissions measurement. The unwanted emissions shall comply with 15.407(b)(1) to (6), and restricted bands per FCC Part15.205.

3.5.1 Limit of Unwanted Emissions

(1) For transmitters operating in the 5150-5250 MHz band: all emissions outside of the 5150-5350 MHz band shall not exceed an EIRP of -27 dBm/MHz.

For transmitters operating in the 5250-5350 MHz band: all emissions outside of the 5150-5350 MHz band shall not exceed an EIRP of -27 dBm/MHz. Devices operating in the 5250-5350 MHz band that generate emissions in the 5150-5250 MHz band must meet all applicable technical requirements for operation in the 5150-5250 MHz band (including indoor use) or alternatively meet an out-of-band emission EIRP limit of -27 dBm/MHz in the 5150-5250 MHz band.

For transmitters operating in the 5470-5600 MHz and 5650-5725MHz band: all emissions outside of the 5470-5600 MHz and 5650-5725MHz band shall not exceed an EIRP of -27 dBm/MHz.

(2) Unwanted spurious emissions fallen in restricted bands per FCC Part15.205 shall comply with the general field strength limits set forth in § 15.209 as below table,

Frequency (MHz)	Field Strength (microvolts/meter)	Measurement Distance (meters)
0.009 – 0.490	2400/F(kHz)	300
0.490 – 1.705	24000/F(kHz)	30
1.705 – 30.0	30	30
30 – 88	100	3
88 – 216	150	3
216 - 960	200	3
Above 960	500	3

Note: The following formula is used to convert the EIRP to field strength.

$$E = \frac{1000000\sqrt{30P}}{3} \mu\text{V/m, where P is the eirp (Watts)}$$

EIRP (dBm)	Field Strength at 3m (dBμV/m)
-17	78.3
-27	68.3

(3) KDB789033 v01r03 H)2)c)(i) As specified in 15.407(b), emissions above 1000 MHz that are outside of the restricted bands are subject to a peak emission limit of -27 dBm/MHz (or -17 dBm/MHz as specified in 15.407(b)(4)). However, an out-of-band emission that complies with both the average and peak limits of 15.209 is not required to satisfy the -27 dBm/MHz or -17 dBm/MHz peak emission limit.

3.5.2 Measuring Instruments

The measuring equipment is listed in the section 4 of this test report.

3.5.3 Test Procedures

1. The testing follows FCC KDB 789033 D01 General UNII Test Procedures v01r03.
Section H) Unwanted emissions measurement.
 - (1) Procedure for Unwanted Emissions Measurements Below 1000MHz
 - RBW = 120 kHz
 - VBW = 300 kHz
 - Detector = Peak
 - Trace mode = max hold
 - (2) Procedure for Peak Unwanted Emissions Measurements Above 1000 MHz
 - The setting follows the H) 5) of FCC KDB 789033.
 - RBW = 1 MHz
 - VBW \geq 3 MHz
 - Detector = Peak
 - Sweep time = auto
 - Trace mode = max hold
 - (3) Procedures for Average Unwanted Emissions Measurements Above 1000MHz
 - The setting follows H) 6) of FCC KDB 789033.
 - RBW = 1 MHz
 - VBW = 10 Hz, when duty cycle is no less than 98 percent.
 - VBW \geq 1/T, when duty cycle is less than 98 percent where T is the minimum transmission duration over which the transmitter is on and is transmitting at its maximum power control level for the tested mode of operation.

Band	Duty Cycle(%)	T(μ s)	1/T(kHz)	VBW Setting
802.11a	93.60	1495.65	0.669	1kHz
802.11n HT20	92.94	1329.71	0.752	1kHz
802.11n HT40	86.53	633.33	1.580	3kHz

2. The EUT was placed on a rotatable table top 0.8 meter above ground.
3. The EUT was set 3 meters from the interference receiving antenna which was mounted on the top of a variable height antenna tower.
4. The antenna is a broadband antenna and its height is adjusted between one meter and four meters above ground to find the maximum value of the field strength for both horizontal polarization and vertical polarization of the antenna.
5. For each suspected emission, the EUT was arranged to its worst case and then adjust the antenna tower (from 1 m to 4 m) and turntable (from 0 degree to 360 degrees) to find the maximum reading.
6. For testing below 1GHz, if the emission level of the EUT in peak mode was 3 dB lower than the limit specified, then peak values of EUT will be reported, otherwise, the emissions will be repeated one by one using the CISPR quasi-peak method and reported.
7. For testing above 1GHz, the emission level of the EUT in peak mode was 20dB lower than average limit (that means the emission level in average mode also complies with the limit in average mode), then peak values of EUT will be reported, otherwise, the emissions will be measured in average mode again and reported.

3.5.4 Test Setup

For radiated emissions below 30MHz

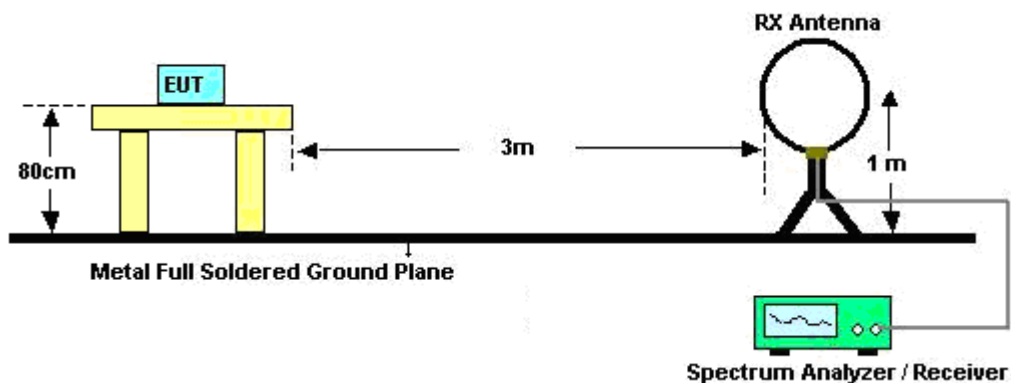

For radiated emissions from 30MHz to 1GHz

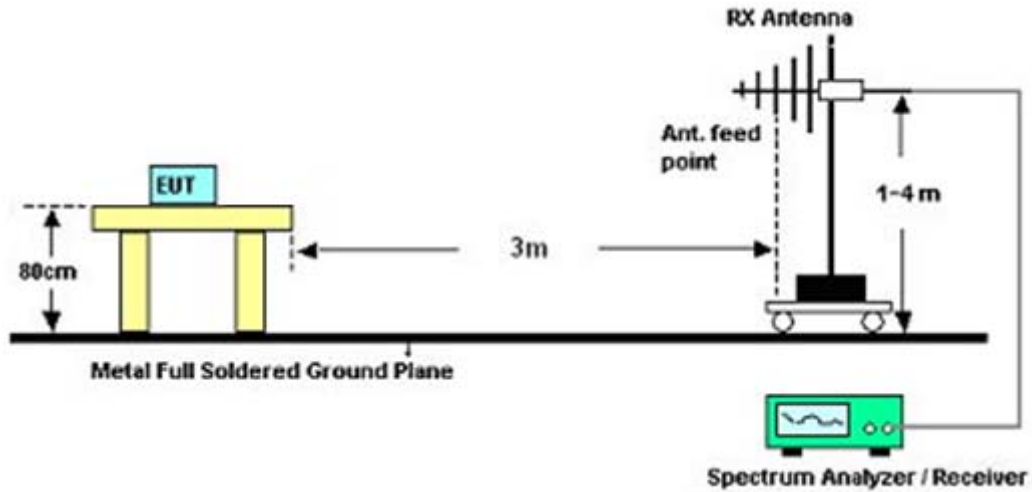

For radiated emissions above 1GHz

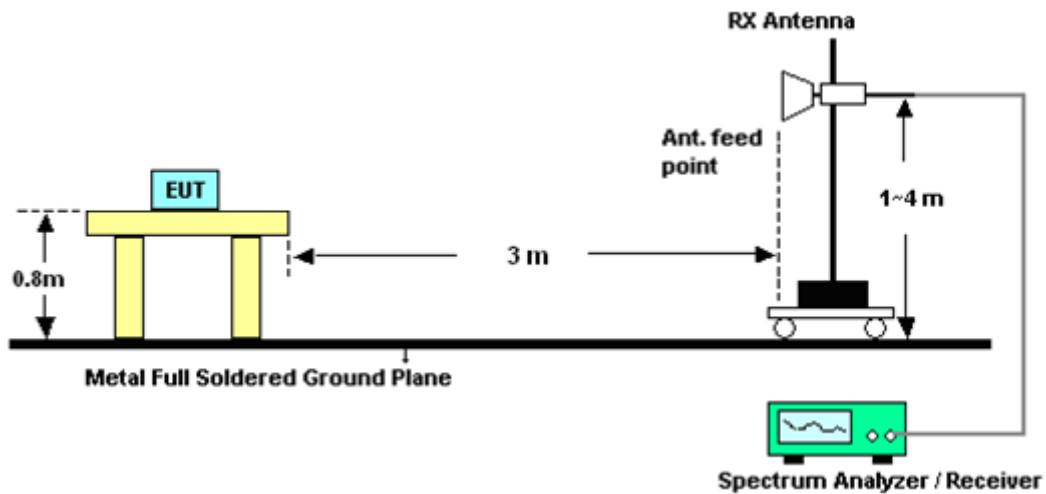

3.5.5 Test Results of Radiated Emissions (9 kHz ~ 30 MHz)

The low frequency, which started from 9 kHz to 30MHz, was pre-scanned and the result which was 20dB lower than the limit line per 15.31(o) was not reported.

3.5.6 Test Result

3.5.6.1 Test Result of Radiated Band Edges

Test Mode :	802.11a	Temperature :	24~26°C
Test Channel :	36	Relative Humidity :	49~52%
Test Engineer :	Robin Luo		

ANTENNA POLARITY : HORIZONTAL										
Frequency (MHz)	Level (dBμV/m)	Over Limit (dB)	Limit Line (dBμV/m)	Read Level (dBμV)	Antenna Factor (dB)	Cable Loss (dB)	Preamp Factor (dB)	Ant Pos (cm)	Table Pos (deg)	Remark
5096.3	53.18	-20.82	74	39.83	34.16	8.64	29.45	100	135	Peak
5150	43.18	-10.82	54	29.8	34.14	8.69	29.45	100	135	Average

ANTENNA POLARITY : VERTICAL										
Frequency (MHz)	Level (dBμV/m)	Over Limit (dB)	Limit Line (dBμV/m)	Read Level (dBμV)	Antenna Factor (dB)	Cable Loss (dB)	Preamp Factor (dB)	Ant Pos (cm)	Table Pos (deg)	Remark
5036.45	53.17	-20.83	74	39.86	34.19	8.57	29.45	100	27	Peak
5148.8	42.99	-11.01	54	29.61	34.14	8.69	29.45	100	27	Average

Test Mode :	802.11a	Temperature :	24~26°C
Test Channel :	48	Relative Humidity :	49~52%
Test Engineer :	Robin Luo		

ANTENNA POLARITY : HORIZONTAL										
Frequency (MHz)	Level (dBμV/m)	Over Limit (dB)	Limit Line (dBμV/m)	Read Level (dBμV)	Antenna Factor (dB)	Cable Loss (dB)	Preamp Factor (dB)	Ant Pos (cm)	Table Pos (deg)	Remark
5392.79	52.83	-21.17	74	39.29	34.05	8.93	29.44	100	187	Peak
5449.11	42.34	-11.66	54	28.78	34.02	8.98	29.44	100	187	Average

ANTENNA POLARITY : VERTICAL										
Frequency (MHz)	Level (dBμV/m)	Over Limit (dB)	Limit Line (dBμV/m)	Read Level (dBμV)	Antenna Factor (dB)	Cable Loss (dB)	Preamp Factor (dB)	Ant Pos (cm)	Table Pos (deg)	Remark
5362.21	52.84	-21.16	74	39.33	34.05	8.9	29.44	100	32	Peak
5404.12	42.27	-11.73	54	28.72	34.04	8.95	29.44	100	32	Average



Test Mode :	802.11a	Temperature :	24~26°C
Test Channel :	52	Relative Humidity :	49~52%
Test Engineer :	Robin Luo		

ANTENNA POLARITY : HORIZONTAL										
Frequency (MHz)	Level (dBμV/m)	Over Limit (dB)	Limit Line (dBμV/m)	Read Level (dBμV)	Antenna Factor (dB)	Cable Loss (dB)	Preamp Factor (dB)	Ant Pos (cm)	Table Pos (deg)	Remark
5110.4	53.36	-20.64	74	40.02	34.15	8.64	29.45	100	243	Peak
5097.5	42.63	-11.37	54	29.28	34.16	8.64	29.45	100	243	Average

ANTENNA POLARITY : VERTICAL										
Frequency (MHz)	Level (dBμV/m)	Over Limit (dB)	Limit Line (dBμV/m)	Read Level (dBμV)	Antenna Factor (dB)	Cable Loss (dB)	Preamp Factor (dB)	Ant Pos (cm)	Table Pos (deg)	Remark
5140.85	53.11	-20.89	74	39.75	34.14	8.67	29.45	100	30	Peak
5141.3	42.75	-11.25	54	29.39	34.14	8.67	29.45	100	30	Average

Test Mode :	802.11a	Temperature :	24~26°C
Test Channel :	64	Relative Humidity :	49~52%
Test Engineer :	Robin Luo		

ANTENNA POLARITY : HORIZONTAL										
Frequency (MHz)	Level (dBμV/m)	Over Limit (dB)	Limit Line (dBμV/m)	Read Level (dBμV)	Antenna Factor (dB)	Cable Loss (dB)	Preamp Factor (dB)	Ant Pos (cm)	Table Pos (deg)	Remark
5455.38	52.62	-21.38	74	39.04	34.02	9	29.44	111	146	Peak
5453.51	42.38	-11.62	54	28.8	34.02	9	29.44	111	146	Average

ANTENNA POLARITY : VERTICAL										
Frequency (MHz)	Level (dBμV/m)	Over Limit (dB)	Limit Line (dBμV/m)	Read Level (dBμV)	Antenna Factor (dB)	Cable Loss (dB)	Preamp Factor (dB)	Ant Pos (cm)	Table Pos (deg)	Remark
5408.52	52.94	-21.06	74	39.39	34.04	8.95	29.44	103	134	Peak
5393.01	42.38	-11.62	54	28.84	34.05	8.93	29.44	103	134	Average



Test Mode :	802.11a	Temperature :	24~26°C
Test Channel :	100	Relative Humidity :	49~52%
Test Engineer :	Robin Luo		

ANTENNA POLARITY : HORIZONTAL										
Frequency (MHz)	Level (dBμV/m)	Over Limit (dB)	Limit Line (dBμV/m)	Read Level (dBμV)	Antenna Factor (dB)	Cable Loss (dB)	Preamp Factor (dB)	Ant Pos (cm)	Table Pos (deg)	Remark
5367.76	52.83	-21.17	74	39.32	34.05	8.9	29.44	100	148	Peak
5388.4	42.28	-11.72	54	28.74	34.05	8.93	29.44	100	148	Average

ANTENNA POLARITY : VERTICAL										
Frequency (MHz)	Level (dBμV/m)	Over Limit (dB)	Limit Line (dBμV/m)	Read Level (dBμV)	Antenna Factor (dB)	Cable Loss (dB)	Preamp Factor (dB)	Ant Pos (cm)	Table Pos (deg)	Remark
5388.4	52.96	-21.04	74	39.42	34.05	8.93	29.44	100	41	Peak
5437.2	42.29	-11.71	54	28.72	34.03	8.98	29.44	100	41	Average

Test Mode :	802.11a	Temperature :	24~26°C
Test Channel :	140	Relative Humidity :	49~52%
Test Engineer :	Robin Luo		

ANTENNA POLARITY : HORIZONTAL										
Frequency (MHz)	Level (dBμV/m)	Over Limit (dB)	Limit Line (dBμV/m)	Read Level (dBμV)	Antenna Factor (dB)	Cable Loss (dB)	Preamp Factor (dB)	Ant Pos (cm)	Table Pos (deg)	Remark
5725.08	59.95	-14.05	74	46.41	34	9.13	29.59	102	129	Peak
5725.16	47.47	-6.53	54	33.93	34	9.13	29.59	102	129	Average

ANTENNA POLARITY : VERTICAL										
Frequency (MHz)	Level (dBμV/m)	Over Limit (dB)	Limit Line (dBμV/m)	Read Level (dBμV)	Antenna Factor (dB)	Cable Loss (dB)	Preamp Factor (dB)	Ant Pos (cm)	Table Pos (deg)	Remark
5725.4	57.91	-16.09	74	44.37	34	9.13	29.59	100	40	Peak
5725.24	46.06	-7.94	54	32.52	34	9.13	29.59	100	40	Average



Test Mode :	802.11n HT20	Temperature :	24~26°C
Test Channel :	36	Relative Humidity :	49~52%
Test Engineer :	Robin Luo		

ANTENNA POLARITY : HORIZONTAL										
Frequency (MHz)	Level (dBμV/m)	Over Limit (dB)	Limit Line (dBμV/m)	Read Level (dBμV)	Antenna Factor (dB)	Cable Loss (dB)	Preamp Factor (dB)	Ant Pos (cm)	Table Pos (deg)	Remark
5073.2	53.38	-20.62	74	40.04	34.17	8.62	29.45	111	40	Peak
5149.25	42.87	-11.13	54	29.49	34.14	8.69	29.45	111	40	Average

ANTENNA POLARITY : VERTICAL										
Frequency (MHz)	Level (dBμV/m)	Over Limit (dB)	Limit Line (dBμV/m)	Read Level (dBμV)	Antenna Factor (dB)	Cable Loss (dB)	Preamp Factor (dB)	Ant Pos (cm)	Table Pos (deg)	Remark
5030.6	53.57	-20.43	74	40.26	34.19	8.57	29.45	127	111	Peak
5148.5	43	-11	54	29.62	34.14	8.69	29.45	127	111	Average

Test Mode :	802.11n HT20	Temperature :	24~26°C
Test Channel :	48	Relative Humidity :	49~52%
Test Engineer :	Robin Luo		

ANTENNA POLARITY : HORIZONTAL										
Frequency (MHz)	Level (dBμV/m)	Over Limit (dB)	Limit Line (dBμV/m)	Read Level (dBμV)	Antenna Factor (dB)	Cable Loss (dB)	Preamp Factor (dB)	Ant Pos (cm)	Table Pos (deg)	Remark
5399.61	53	-21	74	39.45	34.04	8.95	29.44	100	305	Peak
5457.36	42.57	-11.43	54	28.99	34.02	9	29.44	100	305	Average

ANTENNA POLARITY : VERTICAL										
Frequency (MHz)	Level (dBμV/m)	Over Limit (dB)	Limit Line (dBμV/m)	Read Level (dBμV)	Antenna Factor (dB)	Cable Loss (dB)	Preamp Factor (dB)	Ant Pos (cm)	Table Pos (deg)	Remark
5432.17	52.76	-21.24	74	39.19	34.03	8.98	29.44	100	177	Peak
5359.35	42.51	-11.49	54	28.99	34.06	8.9	29.44	100	177	Average



Test Mode :	802.11n HT20	Temperature :	24~26°C
Test Channel :	52	Relative Humidity :	49~52%
Test Engineer :	Robin Luo		

ANTENNA POLARITY : HORIZONTAL										
Frequency (MHz)	Level (dBμV/m)	Over Limit (dB)	Limit Line (dBμV/m)	Read Level (dBμV)	Antenna Factor (dB)	Cable Loss (dB)	Preamp Factor (dB)	Ant Pos (cm)	Table Pos (deg)	Remark
5001.5	53.28	-20.72	74	39.99	34.2	8.54	29.45	110	304	Peak
5097.65	42.57	-11.43	54	29.22	34.16	8.64	29.45	110	304	Average

ANTENNA POLARITY : VERTICAL										
Frequency (MHz)	Level (dBμV/m)	Over Limit (dB)	Limit Line (dBμV/m)	Read Level (dBμV)	Antenna Factor (dB)	Cable Loss (dB)	Preamp Factor (dB)	Ant Pos (cm)	Table Pos (deg)	Remark
5099.45	52.75	-21.25	74	39.4	34.16	8.64	29.45	100	177	Peak
5144.6	42.53	-11.47	54	29.15	34.14	8.69	29.45	100	177	Average

Test Mode :	802.11n HT20	Temperature :	24~26°C
Test Channel :	64	Relative Humidity :	49~52%
Test Engineer :	Robin Luo		

ANTENNA POLARITY : HORIZONTAL										
Frequency (MHz)	Level (dBμV/m)	Over Limit (dB)	Limit Line (dBμV/m)	Read Level (dBμV)	Antenna Factor (dB)	Cable Loss (dB)	Preamp Factor (dB)	Ant Pos (cm)	Table Pos (deg)	Remark
5450.21	53.36	-20.64	74	39.78	34.02	9	29.44	101	137	Peak
5460	42.55	-11.45	54	28.97	34.02	9	29.44	101	137	Average

ANTENNA POLARITY : VERTICAL										
Frequency (MHz)	Level (dBμV/m)	Over Limit (dB)	Limit Line (dBμV/m)	Read Level (dBμV)	Antenna Factor (dB)	Cable Loss (dB)	Preamp Factor (dB)	Ant Pos (cm)	Table Pos (deg)	Remark
5414.9	53.4	-20.6	74	39.86	34.03	8.95	29.44	100	137	Peak
5458.57	42.47	-11.53	54	28.89	34.02	9	29.44	100	137	Average



Test Mode :	802.11n HT20	Temperature :	24~26°C
Test Channel :	100	Relative Humidity :	49~52%
Test Engineer :	Robin Luo		

ANTENNA POLARITY : HORIZONTAL										
Frequency (MHz)	Level (dBμV/m)	Over Limit (dB)	Limit Line (dBμV/m)	Read Level (dBμV)	Antenna Factor (dB)	Cable Loss (dB)	Preamp Factor (dB)	Ant Pos (cm)	Table Pos (deg)	Remark
5453.36	53	-21	74	39.42	34.02	9	29.44	115	146	Peak
5461.04	42.44	-11.56	54	28.86	34.02	9	29.44	115	146	Average

ANTENNA POLARITY : VERTICAL										
Frequency (MHz)	Level (dBμV/m)	Over Limit (dB)	Limit Line (dBμV/m)	Read Level (dBμV)	Antenna Factor (dB)	Cable Loss (dB)	Preamp Factor (dB)	Ant Pos (cm)	Table Pos (deg)	Remark
5458.32	53.89	-20.11	74	40.31	34.02	9	29.44	100	63	Peak
5405.04	42.25	-11.75	54	28.7	34.04	8.95	29.44	100	63	Average

Test Mode :	802.11n HT20	Temperature :	24~26°C
Test Channel :	140	Relative Humidity :	49~52%
Test Engineer :	Robin Luo		

ANTENNA POLARITY : HORIZONTAL										
Frequency (MHz)	Level (dBμV/m)	Over Limit (dB)	Limit Line (dBμV/m)	Read Level (dBμV)	Antenna Factor (dB)	Cable Loss (dB)	Preamp Factor (dB)	Ant Pos (cm)	Table Pos (deg)	Remark
5725	59.58	-14.42	74	46.04	34	9.13	29.59	100	141	Peak
5725	47.1	-6.9	54	33.56	34	9.13	29.59	100	141	Average

ANTENNA POLARITY : VERTICAL										
Frequency (MHz)	Level (dBμV/m)	Over Limit (dB)	Limit Line (dBμV/m)	Read Level (dBμV)	Antenna Factor (dB)	Cable Loss (dB)	Preamp Factor (dB)	Ant Pos (cm)	Table Pos (deg)	Remark
5725	57.07	-16.93	74	43.53	34	9.13	29.59	100	46	Peak
5725	45.54	-8.46	54	32	34	9.13	29.59	100	46	Average



Test Mode :	802.11n HT40	Temperature :	24~26°C
Test Channel :	38	Relative Humidity :	49~52%
Test Engineer :	Robin Luo		

ANTENNA POLARITY : HORIZONTAL										
Frequency (MHz)	Level (dBμV/m)	Over Limit (dB)	Limit Line (dBμV/m)	Read Level (dBμV)	Antenna Factor (dB)	Cable Loss (dB)	Preamp Factor (dB)	Ant Pos (cm)	Table Pos (deg)	Remark
5149.85	53.61	-20.39	74	40.14	34.14	8.69	29.36	119	65	Peak
5149.85	44.88	-9.12	54	31.41	34.14	8.69	29.36	119	65	Average

ANTENNA POLARITY : VERTICAL										
Frequency (MHz)	Level (dBμV/m)	Over Limit (dB)	Limit Line (dBμV/m)	Read Level (dBμV)	Antenna Factor (dB)	Cable Loss (dB)	Preamp Factor (dB)	Ant Pos (cm)	Table Pos (deg)	Remark
5082.05	53.65	-20.35	74	40.21	34.17	8.62	29.35	100	278	Peak
5148.95	44.33	-9.67	54	30.86	34.14	8.69	29.36	100	278	Average

Test Mode :	802.11n HT40	Temperature :	24~26°C
Test Channel :	46	Relative Humidity :	49~52%
Test Engineer :	Robin Luo		

ANTENNA POLARITY : HORIZONTAL										
Frequency (MHz)	Level (dBμV/m)	Over Limit (dB)	Limit Line (dBμV/m)	Read Level (dBμV)	Antenna Factor (dB)	Cable Loss (dB)	Preamp Factor (dB)	Ant Pos (cm)	Table Pos (deg)	Remark
5412.37	52.78	-21.22	74	39.24	34.03	8.95	29.44	100	317	Peak
5459.01	43.28	-10.72	54	29.7	34.02	9	29.44	100	317	Average

ANTENNA POLARITY : VERTICAL										
Frequency (MHz)	Level (dBμV/m)	Over Limit (dB)	Limit Line (dBμV/m)	Read Level (dBμV)	Antenna Factor (dB)	Cable Loss (dB)	Preamp Factor (dB)	Ant Pos (cm)	Table Pos (deg)	Remark
5453.73	52.81	-21.19	74	39.23	34.02	9	29.44	133	308	Peak
5458.57	43.09	-10.91	54	29.51	34.02	9	29.44	133	308	Average



Test Mode :	802.11n HT40	Temperature :	24~26°C
Test Channel :	54	Relative Humidity :	49~52%
Test Engineer :	Robin Luo		

ANTENNA POLARITY : HORIZONTAL										
Frequency (MHz)	Level (dBμV/m)	Over Limit (dB)	Limit Line (dBμV/m)	Read Level (dBμV)	Antenna Factor (dB)	Cable Loss (dB)	Preamp Factor (dB)	Ant Pos (cm)	Table Pos (deg)	Remark
5053.55	53.31	-20.69	74	39.99	34.18	8.59	29.45	100	318	Peak
5104.7	43.46	-10.54	54	30.11	34.16	8.64	29.45	100	318	Average

ANTENNA POLARITY : VERTICAL										
Frequency (MHz)	Level (dBμV/m)	Over Limit (dB)	Limit Line (dBμV/m)	Read Level (dBμV)	Antenna Factor (dB)	Cable Loss (dB)	Preamp Factor (dB)	Ant Pos (cm)	Table Pos (deg)	Remark
5123.6	52.97	-21.03	74	39.6	34.15	8.67	29.45	100	236	Peak
5092.55	43.47	-10.53	54	30.14	34.16	8.62	29.45	100	236	Average

Test Mode :	802.11n HT40	Temperature :	24~26°C
Test Channel :	62	Relative Humidity :	49~52%
Test Engineer :	Robin Luo		

ANTENNA POLARITY : HORIZONTAL										
Frequency (MHz)	Level (dBμV/m)	Over Limit (dB)	Limit Line (dBμV/m)	Read Level (dBμV)	Antenna Factor (dB)	Cable Loss (dB)	Preamp Factor (dB)	Ant Pos (cm)	Table Pos (deg)	Remark
5350.11	61.93	-12.07	74	48.41	34.06	8.9	29.44	100	360	Peak
5350.33	50.69	-3.31	54	37.17	34.06	8.9	29.44	100	360	Average

ANTENNA POLARITY : VERTICAL										
Frequency (MHz)	Level (dBμV/m)	Over Limit (dB)	Limit Line (dBμV/m)	Read Level (dBμV)	Antenna Factor (dB)	Cable Loss (dB)	Preamp Factor (dB)	Ant Pos (cm)	Table Pos (deg)	Remark
5351.65	57.74	-16.26	74	44.22	34.06	8.9	29.44	115	276	Peak
5350.66	48.21	-5.79	54	34.69	34.06	8.9	29.44	115	276	Average



Test Mode :	802.11n HT40	Temperature :	24~26°C
Test Channel :	102	Relative Humidity :	49~52%
Test Engineer :	Robin Luo		

ANTENNA POLARITY : HORIZONTAL										
Frequency (MHz)	Level (dBμV/m)	Over Limit (dB)	Limit Line (dBμV/m)	Read Level (dBμV)	Antenna Factor (dB)	Cable Loss (dB)	Preamp Factor (dB)	Ant Pos (cm)	Table Pos (deg)	Remark
5470	55.16	-18.84	74	41.59	34.01	9	29.44	107	317	Peak
5470	46.08	-7.92	54	32.51	34.01	9	29.44	107	317	Average

ANTENNA POLARITY : VERTICAL										
Frequency (MHz)	Level (dBμV/m)	Over Limit (dB)	Limit Line (dBμV/m)	Read Level (dBμV)	Antenna Factor (dB)	Cable Loss (dB)	Preamp Factor (dB)	Ant Pos (cm)	Table Pos (deg)	Remark
5470	55.67	-18.33	74	42.1	34.01	9	29.44	100	186	Peak
5470	45.71	-8.29	54	32.14	34.01	9	29.44	100	186	Average

Test Mode :	802.11n HT40	Temperature :	24~26°C
Test Channel :	134	Relative Humidity :	49~52%
Test Engineer :	Robin Luo		

ANTENNA POLARITY : HORIZONTAL										
Frequency (MHz)	Level (dBμV/m)	Over Limit (dB)	Limit Line (dBμV/m)	Read Level (dBμV)	Antenna Factor (dB)	Cable Loss (dB)	Preamp Factor (dB)	Ant Pos (cm)	Table Pos (deg)	Remark
5725	54.44	-19.56	74	40.9	34	9.13	29.59	117	312	Peak
5725	45.55	-8.45	54	32.01	34	9.13	29.59	117	312	Average

ANTENNA POLARITY : VERTICAL										
Frequency (MHz)	Level (dBμV/m)	Over Limit (dB)	Limit Line (dBμV/m)	Read Level (dBμV)	Antenna Factor (dB)	Cable Loss (dB)	Preamp Factor (dB)	Ant Pos (cm)	Table Pos (deg)	Remark
5725	55.24	-18.76	74	41.7	34	9.13	29.59	109	270	Peak
5725	46.02	-7.98	54	32.48	34	9.13	29.59	109	270	Average



3.5.6.2 Test Result of Unwanted Radiated Emission (30MHz ~ 10th Harmonic)

Test Mode :	802.11a	Temperature :	24~26°C
Test Channel :	36	Relative Humidity :	49~52%
Test Engineer :	Robin Luo	Polarization :	Horizontal
Remark :	1. 5180 MHz is fundamental signal which can be ignored. 2. 10360 MHz is not within a restricted band and satisfies both the average and peak limits of 15.209.		

Frequency (MHz)	Level (dBμV/m)	Over Limit (dB)	Limit Line (dBμV/m)	Read Level (dBμV)	Antenna Factor (dB)	Cable Loss (dB)	Preamp Factor (dB)	Ant Pos (cm)	Table Pos (deg)	Remark
5180	94.87	-	-	81.47	34.13	8.72	29.45	100	134	Peak
5180	85.94	-	-	72.54	34.13	8.72	29.45	100	134	Average
10360	39.44	-34.56	74	46.72	36.78	12.85	56.91	152	260	Peak

Test Mode :	802.11a	Temperature :	24~26°C
Test Channel :	36	Relative Humidity :	49~52%
Test Engineer :	Robin Luo	Polarization :	Vertical
Remark :	1. 5180 MHz is fundamental signal which can be ignored. 2. 10360 MHz is not within a restricted band and satisfies both the average and peak limits of 15.209.		

Frequency (MHz)	Level (dBμV/m)	Over Limit (dB)	Limit Line (dBμV/m)	Read Level (dBμV)	Antenna Factor (dB)	Cable Loss (dB)	Preamp Factor (dB)	Ant Pos (cm)	Table Pos (deg)	Remark
5180	91.44	-	-	78.04	34.13	8.72	29.45	100	27	Peak
5180	82.74	-	-	69.34	34.13	8.72	29.45	100	27	Average
10360	39.46	-34.54	74	46.74	36.78	12.85	56.91	152	260	Peak



Test Mode :	802.11a	Temperature :	24~26°C
Test Channel :	44	Relative Humidity :	49~52%
Test Engineer :	Robin Luo	Polarization :	Horizontal
Remark :	1. 5220 MHz is fundamental signal which can be ignored. 2. 10440 MHz is not within a restricted band and satisfies both the average and peak limits of 15.209.		

Frequency (MHz)	Level (dBμV/m)	Over Limit (dB)	Limit Line (dBμV/m)	Read Level (dBμV)	Antenna Factor (dB)	Cable Loss (dB)	Preamp Factor (dB)	Ant Pos (cm)	Table Pos (deg)	Remark
5220	97.01	-	-	83.6	34.11	8.75	29.45	100	245	Peak
5220	87.53	-	-	74.12	34.11	8.75	29.45	100	245	Average
10440	38.39	-35.61	74	45.65	36.74	12.89	56.89	125	230	Peak

Test Mode :	802.11a	Temperature :	24~26°C
Test Channel :	44	Relative Humidity :	49~52%
Test Engineer :	Robin Luo	Polarization :	Vertical
Remark :	1. 5220 MHz is fundamental signal which can be ignored. 2. 10440 MHz is not within a restricted band and satisfies both the average and peak limits of 15.209.		

Frequency (MHz)	Level (dBμV/m)	Over Limit (dB)	Limit Line (dBμV/m)	Read Level (dBμV)	Antenna Factor (dB)	Cable Loss (dB)	Preamp Factor (dB)	Ant Pos (cm)	Table Pos (deg)	Remark
5220	89.88	-	-	76.47	34.11	8.75	29.45	100	236	Peak
5220	81.86	-	-	68.45	34.11	8.75	29.45	100	236	Average
10440	42.26	-31.74	74	49.52	36.74	12.89	56.89	125	230	Peak



Test Mode :	802.11a	Temperature :	24~26°C
Test Channel :	48	Relative Humidity :	49~52%
Test Engineer :	Robin Luo	Polarization :	Horizontal
Remark :	1. 5240 MHz is fundamental signal which can be ignored. 2. 10480 MHz is not within a restricted band and satisfies both the average and peak limits of 15.209.		

Frequency (MHz)	Level (dBμV/m)	Over Limit (dB)	Limit Line (dBμV/m)	Read Level (dBμV)	Antenna Factor (dB)	Cable Loss (dB)	Preamp Factor (dB)	Ant Pos (cm)	Table Pos (deg)	Remark
5240	93.75	-	-	80.32	34.11	8.77	29.45	100	186	Peak
5240	85.61	-	-	72.18	34.11	8.77	29.45	100	186	Average
10480	43.06	-30.94	74	50.31	36.71	12.92	56.88	149	289	Peak

Test Mode :	802.11a	Temperature :	24~26°C
Test Channel :	48	Relative Humidity :	49~52%
Test Engineer :	Robin Luo	Polarization :	Vertical
Remark :	1. 5240 MHz is fundamental signal which can be ignored. 2. 10480 MHz is not within a restricted band and satisfies both the average and peak limits of 15.209.		

Frequency (MHz)	Level (dBμV/m)	Over Limit (dB)	Limit Line (dBμV/m)	Read Level (dBμV)	Antenna Factor (dB)	Cable Loss (dB)	Preamp Factor (dB)	Ant Pos (cm)	Table Pos (deg)	Remark
5240	88.51	-	-	75.08	34.11	8.77	29.45	100	31	Peak
5240	80.52	-	-	67.09	34.11	8.77	29.45	100	31	Average
10480	45.2	-28.8	74	52.45	36.71	12.92	56.88	100	0	Peak



Test Mode :	802.11a	Temperature :	24~26°C
Test Channel :	52	Relative Humidity :	49~52%
Test Engineer :	Robin Luo	Polarization :	Horizontal
Remark :	1. 5260 MHz is fundamental signal which can be ignored. 2. 10520 MHz is not within a restricted band and satisfies both the average and peak limits of 15.209.		

Frequency (MHz)	Level (dBμV/m)	Over Limit (dB)	Limit Line (dBμV/m)	Read Level (dBμV)	Antenna Factor (dB)	Cable Loss (dB)	Preamp Factor (dB)	Ant Pos (cm)	Table Pos (deg)	Remark
5260	93.66	-	-	80.21	34.09	8.8	29.44	100	243	Peak
5260	85.01	-	-	71.56	34.09	8.8	29.44	100	243	Average
10520	39.67	-34.33	74	46.9	36.71	12.93	56.87	110	220	Peak

Test Mode :	802.11a	Temperature :	24~26°C
Test Channel :	52	Relative Humidity :	49~52%
Test Engineer :	Robin Luo	Polarization :	Vertical
Remark :	1. 5260 MHz is fundamental signal which can be ignored. 2. 10520 MHz is not within a restricted band and satisfies both the average and peak limits of 15.209.		

Frequency (MHz)	Level (dBμV/m)	Over Limit (dB)	Limit Line (dBμV/m)	Read Level (dBμV)	Antenna Factor (dB)	Cable Loss (dB)	Preamp Factor (dB)	Ant Pos (cm)	Table Pos (deg)	Remark
5260	86.61	-	-	73.16	34.09	8.8	29.44	100	30	Peak
5260	78.88	-	-	65.43	34.09	8.8	29.44	100	30	Average
10520	40.98	-33.02	74	48.21	36.71	12.93	56.87	110	220	Peak



Test Mode :	802.11a	Temperature :	24~26°C
Test Channel :	60	Relative Humidity :	49~52%
Test Engineer :	Robin Luo	Polarization :	Horizontal
Remark :	1. 5300 MHz is fundamental signal which can be ignored. 2. Average measurement was not performed if peak level went lower than the average limit.		

Frequency (MHz)	Level (dBμV/m)	Over Limit (dB)	Limit Line (dBμV/m)	Read Level (dBμV)	Antenna Factor (dB)	Cable Loss (dB)	Preamp Factor (dB)	Ant Pos (cm)	Table Pos (deg)	Remark
5300	91.1	-	-	77.61	34.08	8.85	29.44	100	214	Peak
5300	83.23	-	-	69.74	34.08	8.85	29.44	100	214	Average
10600	38.55	-35.45	74	45.66	36.76	12.98	56.85	185	215	Peak

Test Mode :	802.11a	Temperature :	24~26°C
Test Channel :	60	Relative Humidity :	49~52%
Test Engineer :	Robin Luo	Polarization :	Vertical
Remark :	1. 5300 MHz is fundamental signal which can be ignored. 2. Average measurement was not performed if peak level went lower than the average limit.		

Frequency (MHz)	Level (dBμV/m)	Over Limit (dB)	Limit Line (dBμV/m)	Read Level (dBμV)	Antenna Factor (dB)	Cable Loss (dB)	Preamp Factor (dB)	Ant Pos (cm)	Table Pos (deg)	Remark
5300	84.96	-	-	71.47	34.08	8.85	29.44	100	219	Peak
5300	75.63	-	-	62.14	34.08	8.85	29.44	100	219	Average
10600	38.51	-35.49	74	45.62	36.76	12.98	56.85	185	215	Peak



Test Mode :	802.11a	Temperature :	24~26°C
Test Channel :	64	Relative Humidity :	49~52%
Test Engineer :	Robin Luo	Polarization :	Horizontal
Remark :	1. 5320 MHz is fundamental signal which can be ignored. 2. Average measurement was not performed if peak level went lower than the average limit.		

Frequency (MHz)	Level (dBμV/m)	Over Limit (dB)	Limit Line (dBμV/m)	Read Level (dBμV)	Antenna Factor (dB)	Cable Loss (dB)	Preamp Factor (dB)	Ant Pos (cm)	Table Pos (deg)	Remark
5320	89.59	-	-	76.11	34.07	8.85	29.44	110	145	Peak
5320	81.72	-	-	68.24	34.07	8.85	29.44	110	145	Average
10640	40.39	-33.61	74	47.44	36.78	13.01	56.84	152	135	Peak

Test Mode :	802.11a	Temperature :	24~26°C
Test Channel :	64	Relative Humidity :	49~52%
Test Engineer :	Robin Luo	Polarization :	Vertical
Remark :	1. 5320 MHz is fundamental signal which can be ignored. 2. Average measurement was not performed if peak level went lower than the average limit.		

Frequency (MHz)	Level (dBμV/m)	Over Limit (dB)	Limit Line (dBμV/m)	Read Level (dBμV)	Antenna Factor (dB)	Cable Loss (dB)	Preamp Factor (dB)	Ant Pos (cm)	Table Pos (deg)	Remark
5320	87.1	-	-	73.62	34.07	8.85	29.44	102	134	Peak
5320	78.96	-	-	65.48	34.07	8.85	29.44	102	134	Average
10640	40.29	-33.71	74	47.34	36.78	13.01	56.84	152	135	Peak



Test Mode :	802.11a	Temperature :	24~26°C
Test Channel :	100	Relative Humidity :	49~52%
Test Engineer :	Robin Luo	Polarization :	Horizontal
Remark :	1. 5500 MHz is fundamental signal which can be ignored. 2. Average measurement was not performed if peak level went lower than the average limit.		

Frequency (MHz)	Level (dBμV/m)	Over Limit (dB)	Limit Line (dBμV/m)	Read Level (dBμV)	Antenna Factor (dB)	Cable Loss (dB)	Preamp Factor (dB)	Ant Pos (cm)	Table Pos (deg)	Remark
5500	77.8	-	-	64.21	34	9.03	29.44	100	147	Peak
5500	68.86	-	-	55.27	34	9.03	29.44	100	147	Average
11000	42.18	-31.82	74	48.69	37	13.24	56.75	100	0	Peak

Test Mode :	802.11a	Temperature :	24~26°C
Test Channel :	100	Relative Humidity :	49~52%
Test Engineer :	Robin Luo	Polarization :	Vertical
Remark :	1. 5500 MHz is fundamental signal which can be ignored. 2. Average measurement was not performed if peak level went lower than the average limit.		

Frequency (MHz)	Level (dBμV/m)	Over Limit (dB)	Limit Line (dBμV/m)	Read Level (dBμV)	Antenna Factor (dB)	Cable Loss (dB)	Preamp Factor (dB)	Ant Pos (cm)	Table Pos (deg)	Remark
5500	83.35	-	-	69.76	34	9.03	29.44	100	41	Peak
5500	75.29	-	-	61.7	34	9.03	29.44	100	41	Average
11000	42.01	-31.99	74	48.52	37	13.24	56.75	100	0	Peak



Test Mode :	802.11a	Temperature :	24~26°C
Test Channel :	116	Relative Humidity :	49~52%
Test Engineer :	Robin Luo	Polarization :	Horizontal
Remark :	1. 5580 MHz is fundamental signal which can be ignored. 2. Average measurement was not performed if peak level went lower than the average limit.		

Frequency (MHz)	Level (dBμV/m)	Over Limit (dB)	Limit Line (dBμV/m)	Read Level (dBμV)	Antenna Factor (dB)	Cable Loss (dB)	Preamp Factor (dB)	Ant Pos (cm)	Table Pos (deg)	Remark
5580	86.05	-	-	72.49	34	9.07	29.51	100	214	Peak
5580	76.71	-	-	63.15	34	9.07	29.51	100	214	Average
11160	42.12	-31.88	74	48.19	37.27	13.29	56.63	100	0	Peak

Test Mode :	802.11a	Temperature :	24~26°C
Test Channel :	116	Relative Humidity :	49~52%
Test Engineer :	Robin Luo	Polarization :	Vertical
Remark :	1. 5580 MHz is fundamental signal which can be ignored. 2. Average measurement was not performed if peak level went lower than the average limit.		

Frequency (MHz)	Level (dBμV/m)	Over Limit (dB)	Limit Line (dBμV/m)	Read Level (dBμV)	Antenna Factor (dB)	Cable Loss (dB)	Preamp Factor (dB)	Ant Pos (cm)	Table Pos (deg)	Remark
5580	89.35	-	-	75.79	34	9.07	29.51	100	251	Peak
5580	80.54	-	-	66.98	34	9.07	29.51	100	251	Average
11160	43.56	-30.44	74	49.63	37.27	13.29	56.63	100	0	Peak



Test Mode :	802.11a	Temperature :	24~26°C
Test Channel :	140	Relative Humidity :	49~52%
Test Engineer :	Robin Luo	Polarization :	Horizontal
Remark :	1. 5700 MHz is fundamental signal which can be ignored. 2. Average measurement was not performed if peak level went lower than the average limit.		

Frequency (MHz)	Level (dBμV/m)	Over Limit (dB)	Limit Line (dBμV/m)	Read Level (dBμV)	Antenna Factor (dB)	Cable Loss (dB)	Preamp Factor (dB)	Ant Pos (cm)	Table Pos (deg)	Remark
5700	95.01	-	-	81.47	34	9.12	29.58	101	128	Peak
5700	87.1	-	-	73.56	34	9.12	29.58	101	128	Average
11400	41.9	-32.1	74	47.36	37.64	13.37	56.47	147	285	Peak

Test Mode :	802.11a	Temperature :	24~26°C
Test Channel :	140	Relative Humidity :	49~52%
Test Engineer :	Robin Luo	Polarization :	Vertical
Remark :	1. 5700 MHz is fundamental signal which can be ignored. 2. Average measurement was not performed if peak level went lower than the average limit.		

Frequency (MHz)	Level (dBμV/m)	Over Limit (dB)	Limit Line (dBμV/m)	Read Level (dBμV)	Antenna Factor (dB)	Cable Loss (dB)	Preamp Factor (dB)	Ant Pos (cm)	Table Pos (deg)	Remark
5700	95.35	-	-	81.81	34	9.12	29.58	100	40	Peak
5700	86.94	-	-	73.4	34	9.12	29.58	100	40	Average
11400	45.52	-28.48	74	50.98	37.64	13.37	56.47	147	285	Peak



Test Mode :	802.11n HT20	Temperature :	24~26°C
Test Channel :	36	Relative Humidity :	49~52%
Test Engineer :	Robin Luo	Polarization :	Horizontal
Remark :	1. 5180 MHz is fundamental signal which can be ignored. 2. 10360 MHz is not within a restricted band and satisfies both the average and peak limits of 15.209.		

Frequency (MHz)	Level (dBμV/m)	Over Limit (dB)	Limit Line (dBμV/m)	Read Level (dBμV)	Antenna Factor (dB)	Cable Loss (dB)	Preamp Factor (dB)	Ant Pos (cm)	Table Pos (deg)	Remark
5180	92.08	-	-	78.68	34.13	8.72	29.45	110	39	Peak
5180	83.14	-	-	69.74	34.13	8.72	29.45	110	39	Average
10360	40.43	-33.57	74	47.71	36.78	12.85	56.91	152	260	Peak

Test Mode :	802.11n HT20	Temperature :	24~26°C
Test Channel :	36	Relative Humidity :	49~52%
Test Engineer :	Robin Luo	Polarization :	Vertical
Remark :	1. 5180 MHz is fundamental signal which can be ignored. 2. 10360 MHz is not within a restricted band and satisfies both the average and peak limits of 15.209.		

Frequency (MHz)	Level (dBμV/m)	Over Limit (dB)	Limit Line (dBμV/m)	Read Level (dBμV)	Antenna Factor (dB)	Cable Loss (dB)	Preamp Factor (dB)	Ant Pos (cm)	Table Pos (deg)	Remark
5180	92.71	-	-	79.31	34.13	8.72	29.45	127	111	Peak
5180	83.8	-	-	70.4	34.13	8.72	29.45	127	111	Average
10360	39.46	-34.54	74	46.74	36.78	12.85	56.91	152	260	Peak



Test Mode :	802.11n HT20	Temperature :	24~26°C
Test Channel :	44	Relative Humidity :	49~52%
Test Engineer :	Robin Luo	Polarization :	Horizontal
Remark :	1. 5220 MHz is fundamental signal which can be ignored. 2. 10440 MHz is not within a restricted band and satisfies both the average and peak limits of 15.209.		

Frequency (MHz)	Level (dBμV/m)	Over Limit (dB)	Limit Line (dBμV/m)	Read Level (dBμV)	Antenna Factor (dB)	Cable Loss (dB)	Preamp Factor (dB)	Ant Pos (cm)	Table Pos (deg)	Remark
5220	91.82	-	-	78.41	34.11	8.75	29.45	100	246	Peak
5220	83.09	-	-	69.68	34.11	8.75	29.45	100	246	Average
10440	38.86	-35.14	74	46.12	36.74	12.89	56.89	125	230	Peak

Test Mode :	802.11n HT20	Temperature :	24~26°C
Test Channel :	44	Relative Humidity :	49~52%
Test Engineer :	Robin Luo	Polarization :	Vertical
Remark :	1. 5220 MHz is fundamental signal which can be ignored. 2. 10440 MHz is not within a restricted band and satisfies both the average and peak limits of 15.209.		

Frequency (MHz)	Level (dBμV/m)	Over Limit (dB)	Limit Line (dBμV/m)	Read Level (dBμV)	Antenna Factor (dB)	Cable Loss (dB)	Preamp Factor (dB)	Ant Pos (cm)	Table Pos (deg)	Remark
5220	93.55	-	-	80.14	34.11	8.75	29.45	100	247	Peak
5220	84.74	-	-	71.33	34.11	8.75	29.45	100	247	Average
10440	39.26	-34.74	74	46.52	36.74	12.89	56.89	125	230	Peak



Test Mode :	802.11n HT20	Temperature :	24~26°C
Test Channel :	48	Relative Humidity :	49~52%
Test Engineer :	Robin Luo	Polarization :	Horizontal
Remark :	1. 5240 MHz is fundamental signal which can be ignored. 2. 10480 MHz is not within a restricted band and satisfies both the average and peak limits of 15.209.		

Frequency (MHz)	Level (dBμV/m)	Over Limit (dB)	Limit Line (dBμV/m)	Read Level (dBμV)	Antenna Factor (dB)	Cable Loss (dB)	Preamp Factor (dB)	Ant Pos (cm)	Table Pos (deg)	Remark
5240	90.75	-	-	77.32	34.11	8.77	29.45	100	304	Peak
5240	82.14	-	-	68.71	34.11	8.77	29.45	100	304	Average
10480	40.78	-33.22	74	48.03	36.71	12.92	56.88	149	289	Peak

Test Mode :	802.11n HT20	Temperature :	24~26°C
Test Channel :	48	Relative Humidity :	49~52%
Test Engineer :	Robin Luo	Polarization :	Vertical
Remark :	1. 5240 MHz is fundamental signal which can be ignored. 2. 10480 MHz is not within a restricted band and satisfies both the average and peak limits of 15.209.		

Frequency (MHz)	Level (dBμV/m)	Over Limit (dB)	Limit Line (dBμV/m)	Read Level (dBμV)	Antenna Factor (dB)	Cable Loss (dB)	Preamp Factor (dB)	Ant Pos (cm)	Table Pos (deg)	Remark
5240	91.55	-	-	78.12	34.11	8.77	29.45	100	176	Peak
5240	84.03	-	-	70.6	34.11	8.77	29.45	100	176	Average
10480	40.55	-33.45	74	47.8	36.71	12.92	56.88	149	289	Peak



Test Mode :	802.11n HT20	Temperature :	24~26°C
Test Channel :	52	Relative Humidity :	49~52%
Test Engineer :	Robin Luo	Polarization :	Horizontal
Remark :	1. 5260 MHz is fundamental signal which can be ignored. 2. 10520 MHz is not within a restricted band and satisfies both the average and peak limits of 15.209.		

Frequency (MHz)	Level (dBμV/m)	Over Limit (dB)	Limit Line (dBμV/m)	Read Level (dBμV)	Antenna Factor (dB)	Cable Loss (dB)	Preamp Factor (dB)	Ant Pos (cm)	Table Pos (deg)	Remark
5260	90	-	-	76.55	34.09	8.8	29.44	109	303	Peak
5260	81.94	-	-	68.49	34.09	8.8	29.44	109	303	Average
10520	40.08	-33.92	74	47.31	36.71	12.93	56.87	110	220	Peak

Test Mode :	802.11n HT20	Temperature :	24~26°C
Test Channel :	52	Relative Humidity :	49~52%
Test Engineer :	Robin Luo	Polarization :	Vertical
Remark :	1. 5260 MHz is fundamental signal which can be ignored. 2. 10520 MHz is not within a restricted band and satisfies both the average and peak limits of 15.209.		

Frequency (MHz)	Level (dBμV/m)	Over Limit (dB)	Limit Line (dBμV/m)	Read Level (dBμV)	Antenna Factor (dB)	Cable Loss (dB)	Preamp Factor (dB)	Ant Pos (cm)	Table Pos (deg)	Remark
5260	92.66	-	-	79.21	34.09	8.8	29.44	100	176	Peak
5260	83.47	-	-	70.02	34.09	8.8	29.44	100	176	Average
10520	40.98	-33.02	74	48.21	36.71	12.93	56.87	110	220	Peak



Test Mode :	802.11n HT20	Temperature :	24~26°C
Test Channel :	60	Relative Humidity :	49~52%
Test Engineer :	Robin Luo	Polarization :	Horizontal
Remark :	1. 5300 MHz is fundamental signal which can be ignored. 2. Average measurement was not performed if peak level went lower than the average limit.		

Frequency (MHz)	Level (dBμV/m)	Over Limit (dB)	Limit Line (dBμV/m)	Read Level (dBμV)	Antenna Factor (dB)	Cable Loss (dB)	Preamp Factor (dB)	Ant Pos (cm)	Table Pos (deg)	Remark
5300	85.7	-	-	72.21	34.08	8.85	29.44	100	214	Peak
5300	76.94	-	-	63.45	34.08	8.85	29.44	100	214	Average
10600	38.67	-35.33	74	45.78	36.76	12.98	56.85	185	215	Peak

Test Mode :	802.11n HT20	Temperature :	24~26°C
Test Channel :	60	Relative Humidity :	49~52%
Test Engineer :	Robin Luo	Polarization :	Vertical
Remark :	1. 5300 MHz is fundamental signal which can be ignored. 2. Average measurement was not performed if peak level went lower than the average limit.		

Frequency (MHz)	Level (dBμV/m)	Over Limit (dB)	Limit Line (dBμV/m)	Read Level (dBμV)	Antenna Factor (dB)	Cable Loss (dB)	Preamp Factor (dB)	Ant Pos (cm)	Table Pos (deg)	Remark
5300	90.03	-	-	76.54	34.08	8.85	29.44	100	36	Peak
5300	81.39	-	-	67.9	34.08	8.85	29.44	100	36	Average
10600	38.51	-35.49	74	45.62	36.76	12.98	56.85	185	215	Peak



Test Mode :	802.11n HT20	Temperature :	24~26°C
Test Channel :	64	Relative Humidity :	49~52%
Test Engineer :	Robin Luo	Polarization :	Horizontal
Remark :	1. 5320 MHz is fundamental signal which can be ignored. 2. Average measurement was not performed if peak level went lower than the average limit.		

Frequency (MHz)	Level (dBμV/m)	Over Limit (dB)	Limit Line (dBμV/m)	Read Level (dBμV)	Antenna Factor (dB)	Cable Loss (dB)	Preamp Factor (dB)	Ant Pos (cm)	Table Pos (deg)	Remark
5320	84.97	-	-	71.49	34.07	8.85	29.44	101	137	Peak
5320	76.53	-	-	63.05	34.07	8.85	29.44	101	137	Average
10640	40.52	-33.48	74	47.57	36.78	13.01	56.84	152	135	Peak

Test Mode :	802.11n HT20	Temperature :	24~26°C
Test Channel :	64	Relative Humidity :	49~52%
Test Engineer :	Robin Luo	Polarization :	Vertical
Remark :	1. 5320 MHz is fundamental signal which can be ignored. 2. Average measurement was not performed if peak level went lower than the average limit.		

Frequency (MHz)	Level (dBμV/m)	Over Limit (dB)	Limit Line (dBμV/m)	Read Level (dBμV)	Antenna Factor (dB)	Cable Loss (dB)	Preamp Factor (dB)	Ant Pos (cm)	Table Pos (deg)	Remark
5320	88.49	-	-	75.01	34.07	8.85	29.44	100	136	Peak
5320	79.93	-	-	66.45	34.07	8.85	29.44	100	136	Average
10640	40.29	-33.71	74	47.34	36.78	13.01	56.84	152	135	Peak



Test Mode :	802.11n HT20	Temperature :	24~26°C
Test Channel :	100	Relative Humidity :	49~52%
Test Engineer :	Robin Luo	Polarization :	Horizontal
Remark :	1. 5500 MHz is fundamental signal which can be ignored. 2. Average measurement was not performed if peak level went lower than the average limit.		

Frequency (MHz)	Level (dBμV/m)	Over Limit (dB)	Limit Line (dBμV/m)	Read Level (dBμV)	Antenna Factor (dB)	Cable Loss (dB)	Preamp Factor (dB)	Ant Pos (cm)	Table Pos (deg)	Remark
5500	81.93	-	-	68.34	34	9.03	29.44	115	146	Peak
5500	73.06	-	-	59.47	34	9.03	29.44	115	146	Average
11000	38.96	-35.04	74	45.47	37	13.24	56.75	163	230	Peak

Test Mode :	802.11n HT20	Temperature :	24~26°C
Test Channel :	100	Relative Humidity :	49~52%
Test Engineer :	Robin Luo	Polarization :	Vertical
Remark :	1. 5500 MHz is fundamental signal which can be ignored. 2. Average measurement was not performed if peak level went lower than the average limit.		

Frequency (MHz)	Level (dBμV/m)	Over Limit (dB)	Limit Line (dBμV/m)	Read Level (dBμV)	Antenna Factor (dB)	Cable Loss (dB)	Preamp Factor (dB)	Ant Pos (cm)	Table Pos (deg)	Remark
5500	83.98	-	-	70.39	34	9.03	29.44	100	63	Peak
5500	74.4	-	-	60.81	34	9.03	29.44	100	63	Average
11000	39.68	-34.32	74	46.19	37	13.24	56.75	163	230	Peak



Test Mode :	802.11n HT20	Temperature :	24~26°C
Test Channel :	116	Relative Humidity :	49~52%
Test Engineer :	Robin Luo	Polarization :	Horizontal
Remark :	1. 5580 MHz is fundamental signal which can be ignored. 2. Average measurement was not performed if peak level went lower than the average limit.		

Frequency (MHz)	Level (dBμV/m)	Over Limit (dB)	Limit Line (dBμV/m)	Read Level (dBμV)	Antenna Factor (dB)	Cable Loss (dB)	Preamp Factor (dB)	Ant Pos (cm)	Table Pos (deg)	Remark
5580	83.55	-	-	69.99	34	9.07	29.51	100	245	Peak
5580	75.31	-	-	61.75	34	9.07	29.51	100	245	Average
11160	39.95	-34.05	74	46.02	37.27	13.29	56.63	170	200	Peak

Test Mode :	802.11n HT20	Temperature :	24~26°C
Test Channel :	116	Relative Humidity :	49~52%
Test Engineer :	Robin Luo	Polarization :	Vertical
Remark :	1. 5580 MHz is fundamental signal which can be ignored. 2. Average measurement was not performed if peak level went lower than the average limit.		

Frequency (MHz)	Level (dBμV/m)	Over Limit (dB)	Limit Line (dBμV/m)	Read Level (dBμV)	Antenna Factor (dB)	Cable Loss (dB)	Preamp Factor (dB)	Ant Pos (cm)	Table Pos (deg)	Remark
5580	88.06	-	-	74.5	34	9.07	29.51	100	75	Peak
5580	80.08	-	-	66.52	34	9.07	29.51	100	75	Average
11160	40.15	-33.85	74	46.22	37.27	13.29	56.63	170	200	Peak



Test Mode :	802.11n HT20	Temperature :	24~26°C
Test Channel :	140	Relative Humidity :	49~52%
Test Engineer :	Robin Luo	Polarization :	Horizontal
Remark :	1. 5700 MHz is fundamental signal which can be ignored. 2. Average measurement was not performed if peak level went lower than the average limit.		

Frequency (MHz)	Level (dBμV/m)	Over Limit (dB)	Limit Line (dBμV/m)	Read Level (dBμV)	Antenna Factor (dB)	Cable Loss (dB)	Preamp Factor (dB)	Ant Pos (cm)	Table Pos (deg)	Remark
5700	94.28	-	-	80.74	34	9.12	29.58	100	140	Peak
5700	85.63	-	-	72.09	34	9.12	29.58	100	140	Average
11400	40.63	-33.37	74	46.09	37.64	13.37	56.47	147	285	Peak

Test Mode :	802.11n HT20	Temperature :	24~26°C
Test Channel :	140	Relative Humidity :	49~52%
Test Engineer :	Robin Luo	Polarization :	Vertical
Remark :	1. 5700 MHz is fundamental signal which can be ignored. 2. Average measurement was not performed if peak level went lower than the average limit.		

Frequency (MHz)	Level (dBμV/m)	Over Limit (dB)	Limit Line (dBμV/m)	Read Level (dBμV)	Antenna Factor (dB)	Cable Loss (dB)	Preamp Factor (dB)	Ant Pos (cm)	Table Pos (deg)	Remark
5700	93.66	-	-	80.12	34	9.12	29.58	100	46	Peak
5700	85.66	-	-	72.12	34	9.12	29.58	100	46	Average
11400	41.52	-32.48	74	46.98	37.64	13.37	56.47	147	285	Peak



Test Mode :	802.11n HT40	Temperature :	24~26°C
Test Channel :	38	Relative Humidity :	49~52%
Test Engineer :	Robin Luo	Polarization :	Horizontal
Remark :	1. 5190 MHz is fundamental signal which can be ignored. 2. 10380 MHz is not within a restricted band and satisfies both the average and peak limits of 15.209.		

Frequency (MHz)	Level (dBμV/m)	Over Limit (dB)	Limit Line (dBμV/m)	Read Level (dBμV)	Antenna Factor (dB)	Cable Loss (dB)	Preamp Factor (dB)	Ant Pos (cm)	Table Pos (deg)	Remark
5190	89.04	-	-	75.55	34.13	8.72	29.36	119	65	Peak
5190	80.39	-	-	66.9	34.13	8.72	29.36	119	65	Average
10380	39.49	-34.51	74	46.76	36.77	12.86	56.9	100	0	Peak

Test Mode :	802.11n HT40	Temperature :	24~26°C
Test Channel :	38	Relative Humidity :	49~52%
Test Engineer :	Robin Luo	Polarization :	Vertical
Remark :	1. 5190 MHz is fundamental signal which can be ignored. 2. 10380 MHz is not within a restricted band and satisfies both the average and peak limits of 15.209.		

Frequency (MHz)	Level (dBμV/m)	Over Limit (dB)	Limit Line (dBμV/m)	Read Level (dBμV)	Antenna Factor (dB)	Cable Loss (dB)	Preamp Factor (dB)	Ant Pos (cm)	Table Pos (deg)	Remark
5190	86.13	-	-	72.64	34.13	8.72	29.36	100	278	Peak
5190	78.02	-	-	64.53	34.13	8.72	29.36	100	278	Average
10380	42.75	-31.25	74	50.02	36.77	12.86	56.9	100	360	Peak



Test Mode :	802.11n HT40	Temperature :	24~26°C
Test Channel :	46	Relative Humidity :	49~52%
Test Engineer :	Robin Luo	Polarization :	Horizontal
Remark :	1. 5230 MHz is fundamental signal which can be ignored. 2. 10460 MHz is not within a restricted band and satisfies both the average and peak limits of 15.209.		

Frequency (MHz)	Level (dBμV/m)	Over Limit (dB)	Limit Line (dBμV/m)	Read Level (dBμV)	Antenna Factor (dB)	Cable Loss (dB)	Preamp Factor (dB)	Ant Pos (cm)	Table Pos (deg)	Remark
5230	92.74	-	-	79.31	34.11	8.77	29.45	100	317	Peak
5230	83.87	-	-	70.44	34.11	8.77	29.45	100	317	Average
10460	40.07	-33.93	74	47.33	36.73	12.9	56.89	100	0	Peak

Test Mode :	802.11n HT40	Temperature :	24~26°C
Test Channel :	46	Relative Humidity :	49~52%
Test Engineer :	Robin Luo	Polarization :	Vertical
Remark :	1. 5230 MHz is fundamental signal which can be ignored. 2. 10460 MHz is not within a restricted band and satisfies both the average and peak limits of 15.209.		

Frequency (MHz)	Level (dBμV/m)	Over Limit (dB)	Limit Line (dBμV/m)	Read Level (dBμV)	Antenna Factor (dB)	Cable Loss (dB)	Preamp Factor (dB)	Ant Pos (cm)	Table Pos (deg)	Remark
5230	89.94	-	-	76.51	34.11	8.77	29.45	133	308	Peak
5230	82.54	-	-	69.11	34.11	8.77	29.45	133	308	Average
10460	46.56	-27.44	74	53.82	36.73	12.9	56.89	100	360	Peak



Test Mode :	802.11n HT40	Temperature :	24~26°C
Test Channel :	54	Relative Humidity :	49~52%
Test Engineer :	Robin Luo	Polarization :	Horizontal
Remark :	1. 5270 MHz is fundamental signal which can be ignored. 2. 10540 MHz is not within a restricted band and satisfies both the average and peak limits of 15.209.		

Frequency (MHz)	Level (dBμV/m)	Over Limit (dB)	Limit Line (dBμV/m)	Read Level (dBμV)	Antenna Factor (dB)	Cable Loss (dB)	Preamp Factor (dB)	Ant Pos (cm)	Table Pos (deg)	Remark
5270	91.57	-	-	78.12	34.09	8.8	29.44	100	317	Peak
5270	83.94	-	-	70.49	34.09	8.8	29.44	100	317	Average
10540	40.78	-33.22	74	47.97	36.72	12.95	56.86	100	0	Peak

Test Mode :	802.11n HT40	Temperature :	24~26°C
Test Channel :	54	Relative Humidity :	49~52%
Test Engineer :	Robin Luo	Polarization :	Vertical
Remark :	1. 5270 MHz is fundamental signal which can be ignored. 2. 10540 MHz is not within a restricted band and satisfies both the average and peak limits of 15.209.		

Frequency (MHz)	Level (dBμV/m)	Over Limit (dB)	Limit Line (dBμV/m)	Read Level (dBμV)	Antenna Factor (dB)	Cable Loss (dB)	Preamp Factor (dB)	Ant Pos (cm)	Table Pos (deg)	Remark
5270	83.99	-	-	70.54	34.09	8.8	29.44	100	236	Peak
5270	76.29	-	-	62.84	34.09	8.8	29.44	100	236	Average
10540	45.72	-28.28	74	52.91	36.72	12.95	56.86	100	360	Peak



Test Mode :	802.11n HT40	Temperature :	24~26°C
Test Channel :	62	Relative Humidity :	49~52%
Test Engineer :	Robin Luo	Polarization :	Horizontal
Remark :	1. 5310 MHz is fundamental signal which can be ignored. 2. Average measurement was not performed if peak level went lower than the average limit.		

Frequency (MHz)	Level (dBμV/m)	Over Limit (dB)	Limit Line (dBμV/m)	Read Level (dBμV)	Antenna Factor (dB)	Cable Loss (dB)	Preamp Factor (dB)	Ant Pos (cm)	Table Pos (deg)	Remark
114.39	24.17	-19.33	43.5	42.41	11.05	1.33	30.62	-	-	Peak
236.61	21.7	-24.3	46	38.1	12	1.81	30.21	-	-	Peak
393.75	23.93	-22.07	46	35.63	15.72	2.27	29.69	-	-	Peak
620.73	24.23	-21.77	46	31.94	18.64	2.82	29.17	-	-	Peak
735.19	27.01	-18.99	46	33.08	19.91	3.04	29.02	200	0	Peak
864.2	26.89	-19.11	46	31.81	20.63	3.3	28.85	-	-	Peak
5310	88.91	-	-	75.43	34.07	8.85	29.44	100	360	Peak
5310	81.24	-	-	67.76	34.07	8.85	29.44	100	360	Average
10620	40.29	-33.71	74	47.36	36.77	13	56.84	100	0	Peak



Test Mode :	802.11n HT40	Temperature :	24~26°C
Test Channel :	62	Relative Humidity :	49~52%
Test Engineer :	Robin Luo	Polarization :	Vertical
Remark :	1. 5310 MHz is fundamental signal which can be ignored. 2. Average measurement was not performed if peak level went lower than the average limit.		

Frequency (MHz)	Level (dBμV/m)	Over Limit (dB)	Limit Line (dBμV/m)	Read Level (dBμV)	Antenna Factor (dB)	Cable Loss (dB)	Preamp Factor (dB)	Ant Pos (cm)	Table Pos (deg)	Remark
59.1	19.69	-20.31	40	41.13	8.1	0.99	30.53	-	-	Peak
167.74	22.03	-21.47	43.5	40.11	10.79	1.57	30.44	-	-	Peak
298.69	22.16	-23.84	46	37.16	12.98	2.02	30	-	-	Peak
496.57	22.31	-23.69	46	32	17.13	2.52	29.34	-	-	Peak
621.7	26.2	-19.8	46	33.91	18.64	2.82	29.17	100	0	Peak
976.72	26.8	-27.2	54	30.73	21.3	3.47	28.7	-	-	Peak
5310	87.01	-	-	73.53	34.07	8.85	29.44	115	276	Peak
5310	79.38	-	-	65.9	34.07	8.85	29.44	115	276	Average
10620	42.69	-31.31	74	49.76	36.77	13	56.84	100	360	Peak



Test Mode :	802.11n HT40	Temperature :	24~26°C
Test Channel :	102	Relative Humidity :	49~52%
Test Engineer :	Robin Luo	Polarization :	Horizontal
Remark :	1. 5510 MHz is fundamental signal which can be ignored. 2. Average measurement was not performed if peak level went lower than the average limit.		

Frequency (MHz)	Level (dBμV/m)	Over Limit (dB)	Limit Line (dBμV/m)	Read Level (dBμV)	Antenna Factor (dB)	Cable Loss (dB)	Preamp Factor (dB)	Ant Pos (cm)	Table Pos (deg)	Remark
5510	80.89	-	-	67.31	34	9.04	29.46	107	317	Peak
5510	71.85	-	-	58.27	34	9.04	29.46	107	317	Average
11020	39.66	-34.34	74	46.12	37.03	13.25	56.74	100	0	Peak

Test Mode :	802.11n HT40	Temperature :	24~26°C
Test Channel :	102	Relative Humidity :	49~52%
Test Engineer :	Robin Luo	Polarization :	Vertical
Remark :	1. 5510 MHz is fundamental signal which can be ignored. 2. Average measurement was not performed if peak level went lower than the average limit.		

Frequency (MHz)	Level (dBμV/m)	Over Limit (dB)	Limit Line (dBμV/m)	Read Level (dBμV)	Antenna Factor (dB)	Cable Loss (dB)	Preamp Factor (dB)	Ant Pos (cm)	Table Pos (deg)	Remark
5510	81.62	-	-	68.04	34	9.04	29.46	100	185	Peak
5510	74	-	-	60.42	34	9.04	29.46	100	185	Average
11020	43.09	-30.91	74	49.55	37.03	13.25	56.74	100	360	Peak



Test Mode :	802.11n HT40	Temperature :	24~26°C
Test Channel :	110	Relative Humidity :	49~52%
Test Engineer :	Robin Luo	Polarization :	Horizontal
Remark :	1. 5550 MHz is fundamental signal which can be ignored. 2. Average measurement was not performed if peak level went lower than the average limit.		

Frequency (MHz)	Level (dBμV/m)	Over Limit (dB)	Limit Line (dBμV/m)	Read Level (dBμV)	Antenna Factor (dB)	Cable Loss (dB)	Preamp Factor (dB)	Ant Pos (cm)	Table Pos (deg)	Remark
5550	82.03	-	-	68.45	34	9.05	29.47	100	213	Peak
5550	73.05	-	-	59.47	34	9.05	29.47	100	213	Average
11100	41.58	-32.42	74	47.83	37.16	13.27	56.68	100	0	Peak

Test Mode :	802.11n HT40	Temperature :	24~26°C
Test Channel :	110	Relative Humidity :	49~52%
Test Engineer :	Robin Luo	Polarization :	Vertical
Remark :	1. 5550 MHz is fundamental signal which can be ignored. 2. Average measurement was not performed if peak level went lower than the average limit.		

Frequency (MHz)	Level (dBμV/m)	Over Limit (dB)	Limit Line (dBμV/m)	Read Level (dBμV)	Antenna Factor (dB)	Cable Loss (dB)	Preamp Factor (dB)	Ant Pos (cm)	Table Pos (deg)	Remark
5550	85.83	-	-	72.25	34	9.05	29.47	100	243	Peak
5550	77.26	-	-	63.68	34	9.05	29.47	100	243	Average
11100	45.59	-28.41	74	51.84	37.16	13.27	56.68	100	360	Peak



Test Mode :	802.11n HT40	Temperature :	24~26°C
Test Channel :	134	Relative Humidity :	49~52%
Test Engineer :	Robin Luo	Polarization :	Horizontal
Remark :	1. 5670 MHz is fundamental signal which can be ignored. 2. Average measurement was not performed if peak level went lower than the average limit.		

Frequency (MHz)	Level (dBμV/m)	Over Limit (dB)	Limit Line (dBμV/m)	Read Level (dBμV)	Antenna Factor (dB)	Cable Loss (dB)	Preamp Factor (dB)	Ant Pos (cm)	Table Pos (deg)	Remark
5670	89.55	-	-	76	34	9.11	29.56	116	311	Peak
5670	81.96	-	-	68.41	34	9.11	29.56	116	311	Average
11340	43.01	-30.99	74	48.66	37.53	13.34	56.52	100	0	Peak

Test Mode :	802.11n HT40	Temperature :	24~26°C
Test Channel :	134	Relative Humidity :	49~52%
Test Engineer :	Robin Luo	Polarization :	Vertical
Remark :	1. 5670 MHz is fundamental signal which can be ignored. 2. Average measurement was not performed if peak level went lower than the average limit.		

Frequency (MHz)	Level (dBμV/m)	Over Limit (dB)	Limit Line (dBμV/m)	Read Level (dBμV)	Antenna Factor (dB)	Cable Loss (dB)	Preamp Factor (dB)	Ant Pos (cm)	Table Pos (deg)	Remark
5670	92.44	-	-	78.89	34	9.11	29.56	100	0	Peak
5670	84.4	-	-	70.85	34	9.11	29.56	100	0	Average
11340	47.13	-26.87	74	52.78	37.53	13.34	56.52	100	360	Peak

3.6 AC Conducted Emission Measurement

3.6.1 Limit of AC Conducted Emission

For equipment that is designed to be connected to the public utility (AC) power line, the radio frequency voltage that is conducted back onto the AC power line on any frequency or frequencies within the band 150 kHz to 30 MHz shall not exceed the limits in the following table.

Frequency of emission (MHz)	Conducted limit (dB μ V)	
	Quasi-peak	Average
0.15-0.5	66 to 56*	56 to 46*
0.5-5	56	46
5-30	60	50

*Decreases with the logarithm of the frequency.

3.6.2 Measuring Instruments

The measuring equipment is listed in the section 4 of this test report.

3.6.3 Test Procedures

1. The EUT was placed 0.4 meter from the conducting wall of the shielding room was kept at least 80 centimeters from any other grounded conducting surface.
2. Connect EUT to the power mains through a line impedance stabilization network (LISN).
3. All the support units are connecting to the other LISN.
4. The LISN provides 50 ohm coupling impedance for the measuring instrument.
5. The FCC states that a 50 ohm, 50 microhenry LISN should be used.
6. Both sides of AC line were checked for maximum conducted interference.
7. The frequency range from 150 kHz to 30 MHz was searched.
8. Set the test-receiver system to Peak Detect Function and specified bandwidth with Maximum Hold Mode.

3.6.4 Test Setup

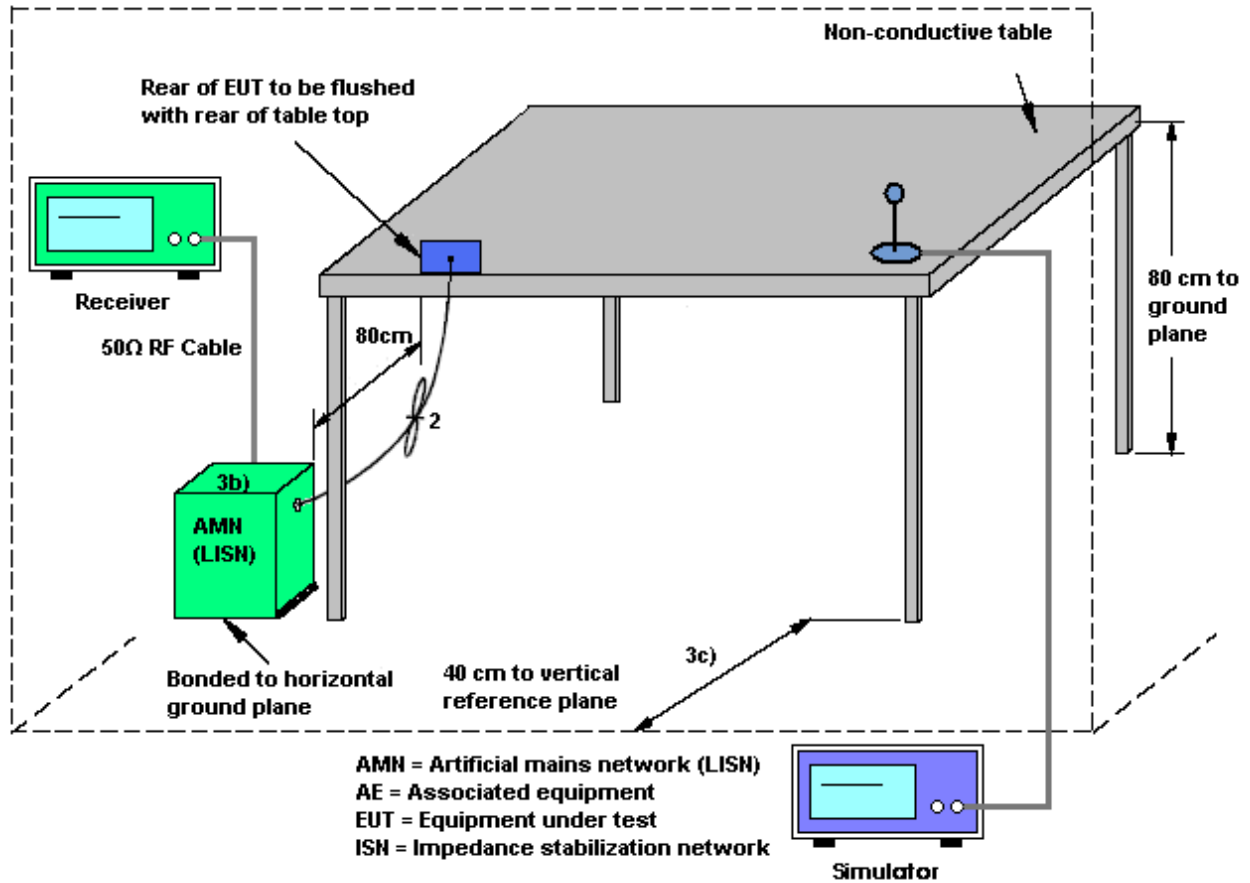



3.6.5 Test Result of AC Conducted Emission

Test Mode :	Mode 1	Temperature :	21~22°C
Test Engineer :	Leo Liao	Relative Humidity :	41~42%
Test Voltage :	120Vac / 60Hz	Phase :	Line
Function Type :	GSM1900 Idle + Bluetooth Link + WLAN (5GHz) Link + Eaphone + NFC On + USB Cable (Charging from Adapter) + SIM 2		

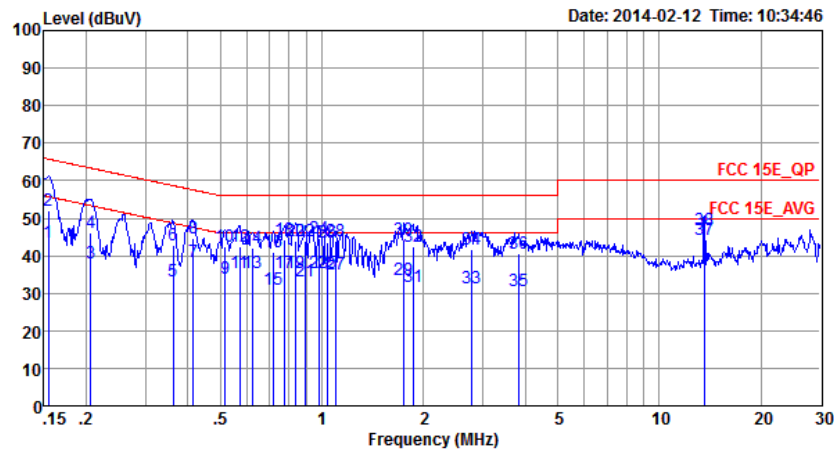

Site : CO01-SZ
 Condition: FCC 15E_QP LISN_L_20130328 LINE
 Mode : Mode 1

	Freq	Level	Over Limit	Limit Line	Read Level	LISN Factor	Cable Loss	Remark
	MHz	dBuV	dB	dBuV	dBuV	dB	dB	
1	0.15	43.71	-12.03	55.74	33.30	0.06	10.35	Average
2	0.15	51.91	-13.83	65.74	41.50	0.06	10.35	QP
3	0.21	38.06	-15.30	53.36	27.70	0.07	10.29	Average
4	0.21	45.96	-17.40	63.36	35.60	0.07	10.29	QP
5	0.36	33.10	-15.59	48.69	22.80	0.12	10.18	Average
6	0.36	42.80	-15.89	58.69	32.50	0.12	10.18	QP
7	0.41	38.29	-9.26	47.55	27.99	0.13	10.17	Average
8	0.41	44.59	-12.96	57.55	34.29	0.13	10.17	QP
9	0.52	33.80	-12.20	46.00	23.50	0.14	10.16	Average
10	0.52	42.30	-13.70	56.00	32.00	0.14	10.16	QP
11	0.57	35.40	-10.60	46.00	25.10	0.15	10.15	Average
12	0.57	42.50	-13.50	56.00	32.20	0.15	10.15	QP
13	0.62	35.50	-10.50	46.00	25.20	0.15	10.15	Average
14	0.62	42.10	-13.90	56.00	31.80	0.15	10.15	QP
15	0.72	31.11	-14.89	46.00	20.80	0.16	10.15	Average
16	0.72	41.11	-14.89	56.00	30.80	0.16	10.15	QP
17	0.78	35.52	-10.48	46.00	25.20	0.17	10.15	Average
18	0.78	44.12	-11.88	56.00	33.80	0.17	10.15	QP
19	0.83	35.33	-10.67	46.00	25.00	0.18	10.15	Average
20	0.83	43.83	-12.17	56.00	33.50	0.18	10.15	QP
21	0.89	33.14	-12.86	46.00	22.80	0.19	10.15	Average
22	0.89	44.04	-11.96	56.00	33.70	0.19	10.15	QP
23	0.98	35.35	-10.65	46.00	25.00	0.20	10.15	Average
24	0.98	44.65	-11.35	56.00	34.30	0.20	10.15	QP
25	1.04	35.55	-10.45	46.00	25.20	0.20	10.15	Average
26	1.04	43.45	-12.55	56.00	33.10	0.20	10.15	QP
27	1.10	35.16	-10.84	46.00	24.80	0.20	10.16	Average
28	1.10	43.86	-12.14	56.00	33.50	0.20	10.16	QP
29	1.75	33.61	-12.39	46.00	23.21	0.22	10.18	Average



Test Mode :	Mode 1	Temperature :	21~22°C
Test Engineer :	Leo Liao	Relative Humidity :	41~42%
Test Voltage :	120Vac / 60Hz	Phase :	Line
Function Type :	GSM1900 Idle + Bluetooth Link + WLAN (5GHz) Link + Eaphone + NFC On + USB Cable (Charging from Adapter) + SIM 2		

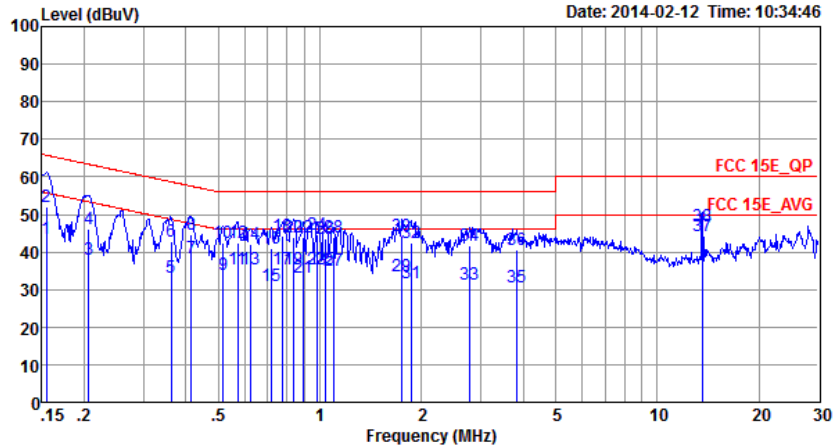

Site : C001-SZ
 Condition: FCC 15E QP LISN L 20130328 LINE
 Mode : Mode 1

	Freq	Level	Over Limit	Limit Line	Read Level	LISN Factor	Cable Loss	Remark
	MHz	dBuV	dB	dBuV	dBuV	dB	dB	
30	1.75	44.21	-11.79	56.00	33.81	0.22	10.18	QP
31	1.86	31.91	-14.09	46.00	21.50	0.23	10.18	Average
32	1.86	42.41	-13.59	56.00	32.00	0.23	10.18	QP
33	2.78	31.47	-14.53	46.00	21.00	0.26	10.21	Average
34	2.78	41.67	-14.33	56.00	31.20	0.26	10.21	QP
35	3.82	30.61	-15.39	46.00	20.10	0.29	10.22	Average
36	3.82	40.71	-15.29	56.00	30.20	0.29	10.22	QP
37 *	13.62	44.34	-5.66	50.00	33.00	0.86	10.48	Average
38	13.62	46.84	-13.16	60.00	35.50	0.86	10.48	QP



Test Mode :	Mode 1	Temperature :	21~22°C
Test Engineer :	Leo Liao	Relative Humidity :	41~42%
Test Voltage :	120Vac / 60Hz	Phase :	Neutral
Function Type :	GSM1900 Idle + Bluetooth Link + WLAN (5GHz) Link + Eaphone + NFC On + USB Cable (Charging from Adapter) + SIM 2		

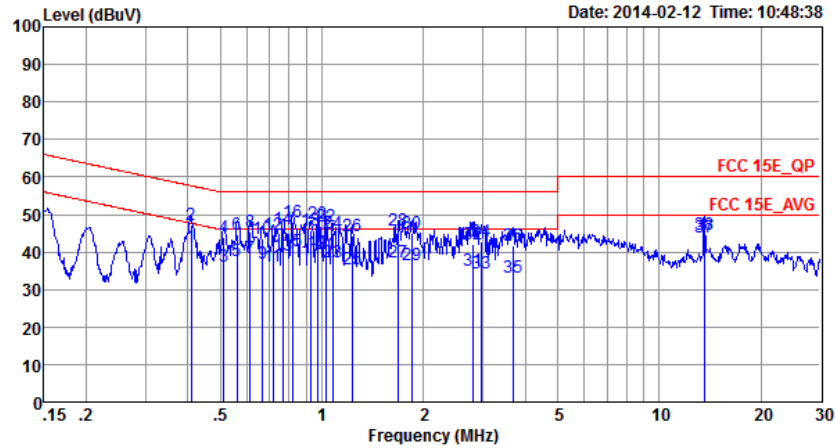

Site : C001-SZ
 Condition: FCC 15E_QP LISN_N_20130328 NEUTRAL

Mode : Mode 1

	Freq	Level	Over	Limit	Read	LISN	Cable	
	MHz	dBuV	Limit	Line	Level	Factor	Loss	Remark
			dB	dBuV	dBuV	dB	dB	
1	0.41	41.51	-6.13	47.64	31.30	0.04	10.17	Average
2	0.41	47.21	-10.43	57.64	37.00	0.04	10.17	QP
3	0.51	36.20	-9.80	46.00	26.00	0.04	10.16	Average
4	0.51	44.00	-12.00	56.00	33.80	0.04	10.16	QP
5	0.56	37.79	-8.21	46.00	27.60	0.04	10.15	Average
6	0.56	44.59	-11.41	56.00	34.40	0.04	10.15	QP
7	0.61	38.39	-7.61	46.00	28.20	0.04	10.15	Average
8	0.61	45.49	-10.51	56.00	35.30	0.04	10.15	QP
9	0.67	36.89	-9.11	46.00	26.70	0.04	10.15	Average
10	0.67	43.49	-12.51	56.00	33.30	0.04	10.15	QP
11	0.72	36.09	-9.91	46.00	25.90	0.04	10.15	Average
12	0.72	44.79	-11.21	56.00	34.60	0.04	10.15	QP
13	0.77	38.99	-7.01	46.00	28.80	0.04	10.15	Average
14	0.77	46.09	-9.91	56.00	35.90	0.04	10.15	QP
15 *	0.82	40.29	-5.71	46.00	30.10	0.04	10.15	Average
16	0.82	47.99	-8.01	56.00	37.80	0.04	10.15	QP
17	0.92	37.49	-8.51	46.00	27.30	0.04	10.15	Average
18	0.92	45.69	-10.31	56.00	35.50	0.04	10.15	QP
19	0.97	39.69	-6.31	46.00	29.50	0.04	10.15	Average
20	0.97	47.49	-8.51	56.00	37.30	0.04	10.15	QP
21	1.03	39.49	-6.51	46.00	29.30	0.04	10.15	Average
22	1.03	46.69	-9.31	56.00	36.50	0.04	10.15	QP
23	1.08	37.40	-8.60	46.00	27.21	0.04	10.15	Average
24	1.08	45.00	-11.00	56.00	34.81	0.04	10.15	QP
25	1.24	35.41	-10.59	46.00	25.20	0.05	10.16	Average
26	1.24	44.11	-11.89	56.00	33.90	0.05	10.16	QP
27	1.69	37.23	-8.77	46.00	26.99	0.06	10.18	Average
28	1.69	45.73	-10.27	56.00	35.49	0.06	10.18	QP
29	1.85	36.44	-9.56	46.00	26.20	0.06	10.18	Average



Test Mode :	Mode 1	Temperature :	21~22°C
Test Engineer :	Leo Liao	Relative Humidity :	41~42%
Test Voltage :	120Vac / 60Hz	Phase :	Neutral
Function Type :	GSM1900 Idle + Bluetooth Link + WLAN (5GHz) Link + Eaphone + NFC On + USB Cable (Charging from Adapter) + SIM 2		

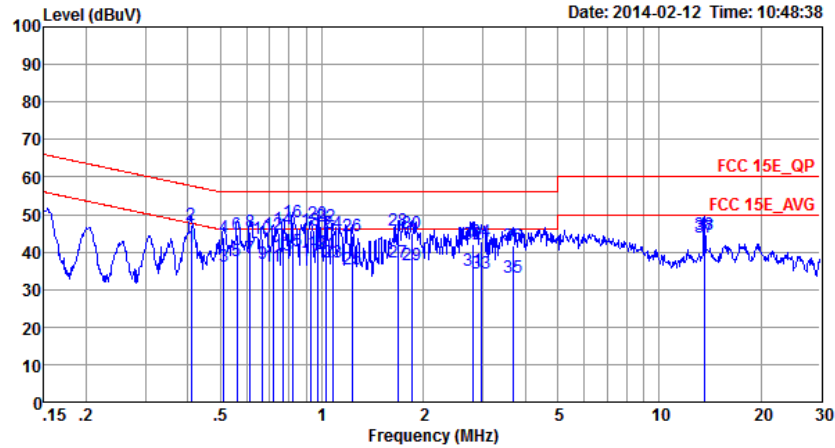

Site : C001-SZ
 Condition: FCC 15E_QP LISN_N_20130328 NEUTRAL
 Mode : Mode 1

	Freq	Level	Over Limit	Limit Line	Read Level	LISN Factor	Cable Loss	Remark
	MHz	dBuV	dB	dBuV	dBuV	dB	dB	
30	1.85	45.04	-10.96	56.00	34.80	0.06	10.18	QP
31	2.81	34.89	-11.11	46.00	24.60	0.08	10.21	Average
32	2.81	42.09	-13.91	56.00	31.80	0.08	10.21	QP
33	2.98	34.29	-11.71	46.00	24.00	0.08	10.21	Average
34	2.98	42.69	-13.31	56.00	32.40	0.08	10.21	QP
35	3.70	33.12	-12.88	46.00	22.81	0.09	10.22	Average
36	3.70	41.82	-14.18	56.00	31.51	0.09	10.22	QP
37	13.62	43.96	-6.04	50.00	33.00	0.48	10.48	Average
38	13.62	44.56	-15.44	60.00	33.60	0.48	10.48	QP

3.7 Frequency Stability Measurement

3.7.1 Limit of Frequency Stability

Manufacturers of U-NII devices are responsible for ensuring frequency stability such that an emission is maintained within the band of operation under all conditions of normal operation as specified in the user's manual.

3.7.2 Measuring Instruments

The measuring equipment is listed in the section 4 of this test report.

3.7.3 Test Procedures

1. To ensure emission at the band edge is maintained within the authorized band, those values shall be measured by radiation emissions at upper and lower frequency points, and finally compensated by frequency deviation as procedures below.
2. The EUT was operated at the maximum output power, and connected to the spectrum analyzer, which is set to maximum hold function and peak detector. The peak value of the power envelope was measured and noted. The upper and lower frequency points were respectively measured relatively 10dB lower than the measured peak value.
3. The frequency deviation was calculated by adding the upper frequency point and the lower frequency point divided by two. Those detailed values of frequency deviation are provided in table below.

3.7.4 Test Setup

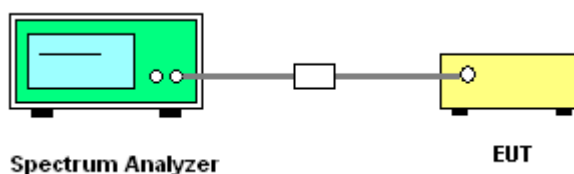



3.7.5 Test Result of Frequency Stability

Test Band :	5GHz band 1,2,3	Temperature :	24~26°C
Test Engineer :	Blithe Li	Relative Humidity :	50~53%

Mod.	Data Rate	N _{TX}	Channel	Frequency (MHz)	Center Frequency (Hz)	Frequency Deviation (Hz)	Frequency Stability (ppm)
11a	6Mbps	1	36	5180	5180000000.00	0.00	0.00
11a	6Mbps	1	48	5240	5240050000.00	50000.00	9.54

Mod.	Data Rate	N _{TX}	Channel	Freq. (MHz)	Center Frequency (Hz)	Frequency Deviation (Hz)	Frequency Stability (ppm)
11a	6Mbps	1	52	5260	5260000000.00	0.00	0.00
11a	6Mbps	1	64	5320	5320050000.00	50000.00	9.40

Mod.	Data Rate	N _{TX}	Channel	Freq. (MHz)	Center Frequency (Hz)	Frequency Deviation (Hz)	Frequency Stability (ppm)
11a	6Mbps	1	100	5500	5500050000.00	50000.00	9.09
11a	6Mbps	1	140	5700	5700050000.00	50000.00	8.77

Note: Center Frequency = (Low Frequency + High Frequency) / 2.

3.8 Automatically Discontinue Transmission

3.8.1 Limit of Automatically Discontinue Transmission

The device shall automatically discontinue transmission in case of either absence of information to transmit or operational failure. These provisions are not intended to preclude the transmission of control or signaling information or the use of repetitive codes used by certain digital technologies to complete frame or burst intervals. Applicants shall include in their application for equipment authorization to describe how this requirement is met.

3.8.2 Measuring Instruments

The measuring equipment is listed in the section 4 of this test report.

3.8.3 Test Result of Automatically Discontinue Transmission

While the EUT is not transmitting any information, the EUT can automatically discontinue transmission and become standby mode for power saving. The EUT can detect the controlling signal of ACK message transmitting from remote device and verify whether it shall resend or discontinue transmission.



3.9 Antenna Requirements

3.9.1 Standard Applicable

According to FCC 47 CFR Section 15.407(a)(1)(2), if transmitting antenna directional gain is greater than 6 dBi, both the peak transmit power and the peak power spectral density shall be reduced by the amount in dB that the directional gain of the antenna exceeds 6 dBi.

3.9.2 Antenna Anti-Replacement Construction

An embedded-in antenna design is used.

3.9.3 Antenna Gain

The antenna gain is less than 6 dBi. Therefore, it is not necessary to reduce maximum peak output power limit.

4 List of Measuring Equipment

Instrument	Manufacturer	Model No.	Serial No.	Characteristics	Calibration Date	Test Date	Due Date	Remark
Spectrum Analyzer	R&S	FSP30	101400	9kHz~30GHz	Mar. 28, 2013	Jan. 14, 2014~ Feb. 07, 2014	Mar. 27, 2014	Conducted (TH01-SZ)
Spectrum Analyzer	R&S	FSV40	101078	10Hz~40GHz	Jun. 17, 2013	Jan. 09, 2014 ~ Jan. 15, 2014	Jun. 16, 2014	Conducted (TH01-SZ)
Power Meter	Anritsu	ML2495A	1218010	13dBm~20dBm	Mar. 28, 2013	Jan. 14, 2014~ Feb. 07, 2014	Mar. 27, 2014	Conducted (TH01-SZ)
Power Sensor	Anritsu	MA2411B	1207253	0.3GHz~40GHz	Mar. 28, 2013	Jan. 14, 2014~ Feb. 07, 2014	Mar. 27, 2014	Conducted (TH01-SZ)
Spectrum Analyzer	Agilent Technologies	N9038A	MY52260185	20Hz~26.5GHz	Apr. 04, 2013	Jan. 15, 2014~ Feb. 10, 2014	Apr. 03, 2014	Radiation (03CH01-SZ)
Spectrum Analyzer	R&S	FSV40	101078	10Hz~40GHz	Jun. 17, 2013	Jan. 15, 2014~ Feb. 10, 2014	Jun. 16, 2014	Radiation (03CH01-SZ)
Loop Antenna	R&S	HFH2-Z2	100354	9kHz~30MHz	May 29, 2013	Jan. 15, 2014~ Feb. 10, 2014	May 28, 2014	Radiation (03CH01-SZ)
SHF-EHF-Horn	Schwarzbeck	BBHA9170	BBHA9170249	14GHz~40GHz	Jan. 13, 2014	Jan. 15, 2014~ Feb. 10, 2014	Jan. 12, 2015	Radiation (03CH01-SZ)
Bilog Antenna	SCHAFFNER	CBL6112B	2614	30MHz~2GHz	Dec. 25, 2013	Jan. 15, 2014~ Feb. 10, 2014	Dec. 24, 2014	Radiation (03CH01-SZ)
Double Ridge Horn Antenna	ETS Lindgren	3117	00119436	1GHz~18GHz	Oct. 26, 2013	Jan. 15, 2014~ Feb. 10, 2014	Oct. 25, 2014	Radiation (03CH01-SZ)
Amplifier	ADVANTEST	BB525C	E9007003	9kHz~3000MHz Gain 30db	Mar. 29, 2013	Jan. 15, 2014~ Feb. 10, 2014	Mar. 28, 2014	Radiation (03CH01-SZ)
Amplifier	Yiai	AV3860B	04030	2GHz~26.5GHz	Mar. 29, 2013	Jan. 15, 2014~ Feb. 10, 2014	Mar. 28, 2014	Radiation (03CH01-SZ)
Amplifier	EM	EM18G40G	060604	18GHz ~ 40GHz	Jun. 20, 2013	Jan. 15, 2014~ Feb. 10, 2014	Jun. 19, 2014	Radiation (03CH01-SZ)
Turn Table	EM Electronics	EM 1000	N/A	0~360 degree	NCR	Jan. 15, 2014~ Feb. 10, 2014	NCR	Radiation (03CH01-SZ)
Antenna Mast	EM Electronics	EM 1000	N/A	1 m~4 m	NCR	Jan. 15, 2014~ Feb. 10, 2014	NCR	Radiation (03CH01-SZ)
ESCIO Test Receiver	R&S	ESCI	100724	9kHz~3GHz	Mar. 29, 2013	Feb. 12, 2014	Mar. 28, 2014	Conduction (CO01-SZ)
AC LISN	EMCO	3816/2SH	00103912	9kHz~30MHz	Mar. 28, 2013	Feb. 12, 2014	Mar. 27, 2014	Conduction (CO01-SZ)
AC LISN (for auxiliary equipment)	EMCO	3816/2SH	00103892	9kHz~30MHz	Mar. 28, 2013	Feb. 12, 2014	Mar. 27, 2014	Conduction (CO01-SZ)
AC Power Source	Chroma	61602	616020000891	100Vac~250Vac	Dec. 17, 2013	Feb. 12, 2014	Dec. 16, 2014	Conduction (CO01-SZ)



5 Uncertainty of Evaluation

Uncertainty of Conducted Emission Measurement (150kHz ~ 30MHz)

Measuring Uncertainty for a Level of Confidence of 95% ($U = 2Uc(y)$)	2.31
---	------

Uncertainty of Radiated Emission Measurement (30 MHz ~ 1000 MHz)

Measuring Uncertainty for a Level of Confidence of 95% ($U = 2Uc(y)$)	3.90
---	------