

10. FUNCTIONS OF DEVICE

No	Name	Vender Code	Description
1	F401	FAR-D5CC-881M50-D1A6	Duplexer
2	Q403	RF2361	Low Noise Amplifier
3	U402	CMY210	Down-Converter
4	Q409	AT32033	RX Drive Amplifier
5	U404	P01204NA	Phase Locked Loop Module
6	Q405,Q406	AT32011	Buffer Amplifier
7	U302	RF2628TR13	Up-Converter
8	Q410	BFP420	Tx Drive Amplifier
9	U304	RI23124U	Power Amplifier
10	F310	CE053R836DCB	Isolator
11	OSC401	KT16-DCV30L-19.680M-T	Temperature Compansated Crystal Oscillator

List of Equipment

- DC Power Supply
- Test Zig
- Test Cable
- CDMA Mobile Station Test Set HP8924C
- Spectrum Analyzer(include COMA Test Mode) HP8596E

Configuration of Test

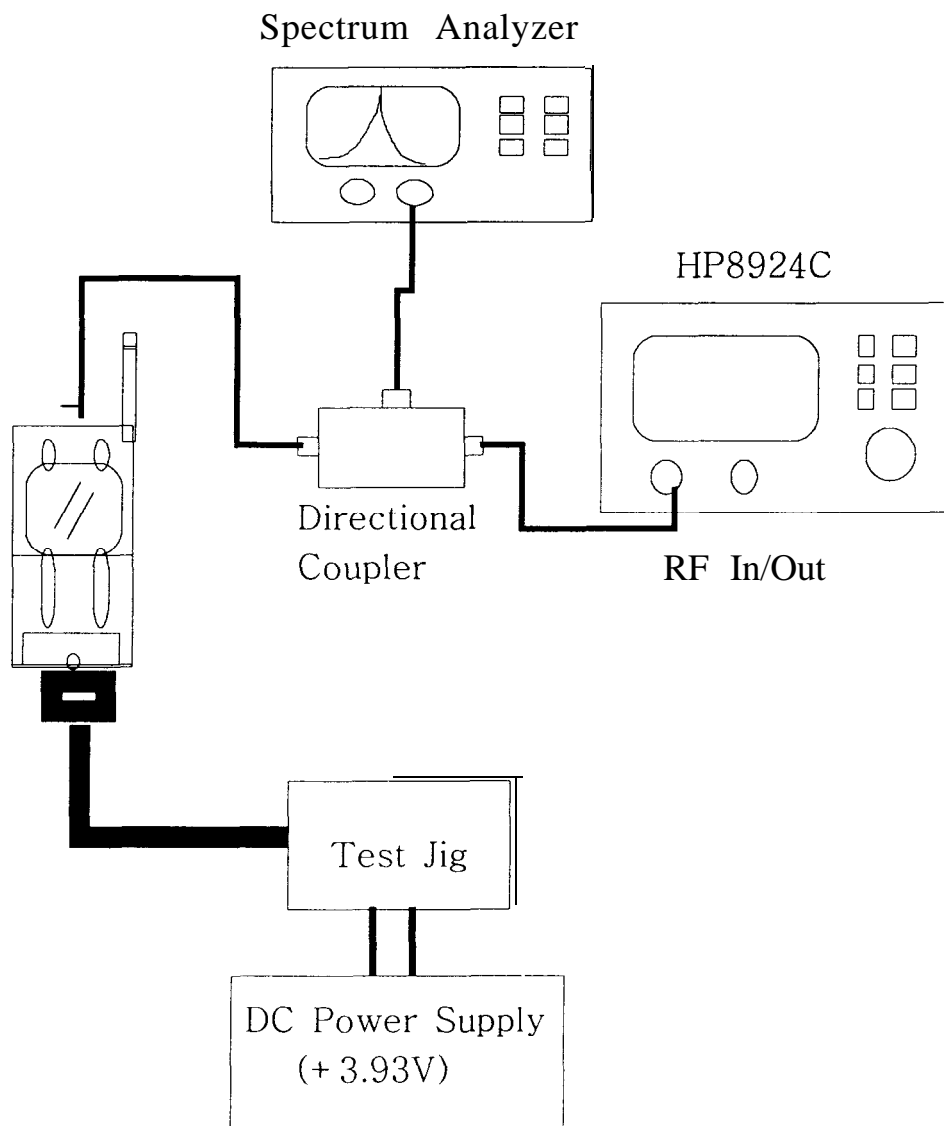

Change to Test Mode

A. To change the phone's state from Normal Mode to Test Mode, you should enter the following keys.

"*7 5 9 # 8 1 3 5 8 0"

B. The command "01" is Suspend.

C. To finish the Test Mode, you should enter the command "0 2".

Channel Selection and Tx Power Output Level Control.

A. Enter to Test Mode ("*7 5 9 # 8 1 3 5 8 0")

B. Suspend ("01")

C. Set to "363" channel ("0 9 0 3 6 3")

D. Carrier On ("07")

E. Spread spectrum to 1.23MHz band width ("34")

F. Output level setting to AGC level ("71")

AGC level range is from 0 to 5 11.

TEST ITEM	PROCEDURE
1. PREPARATION	Setup the test equipment. "*7 5 9 # 8 1 3 5 8 0" : Enter to Test Mode "0 1" : Suspend If you press a wrong key, press "#", then enter new command. To exit the Test Mode at any time, enter "0 2".
2. FREQUENCY ACCURACY	"0 1" : Suspend. "0 9 0 3 6 3" : Set to "0363" channel. "0 7" : Carrier On. "7 1" : Set AGC level. Measure the Tx frequency : 835.89MHz \pm 300Hz
3. OCCUPIED CDMA BANDWIDTH	"0 1 " : Suspend "0 9 0 3 6 3" : Set to "0363" channel. "0 7" : Carrier On. "3 4" : Spread spectrum. "7 1" : Set AGC level. Measure the bandwidth.
4. LIMITATIONS ON EMISSION	"01" : Suspend "0 9 0 3 6 3" : Set to "0363" channel. "0 7" : Carrier On. "3 4" : Spread spectrum. "7 1" : Set AGC level. Measure the spurious at $F_c \pm 900\text{KHz} / \pm 1.98\text{MHz}$ $2F_c, 3F_c, 1/2F_c$
5. GATED POWER & TIME	Set the service option : 2 Set the data rate : Eighth (1200bps) Registering & Call Measure the Gated Power & Time.

TEST COMMAND LIST

Command No	Command SW Name	Description
01(1F,0,0)	T_SUSPEND_I	Terminate the normal mode, enter to the test mode
02(3F,0,0)	T-RESTART-I	Terminate the test mode. enter to the normal mode
07(81,0,0)	T_CARRIERON_I	Turn on the carrier
08(82,0,0)	T_CARRIEROFF_I	Turn off the carrier
09(83,4,0)	T_LOADSYN_I	Set the synthesizer to the channel specified by ch_data
10(84,1,0)	T_PWRLEVEL_I	Change RF power level
11(85,0,0)	T_RXMUTE_I	Mute rx audio
12(86,0,0)	T_RXUNMUTE_I	Unmute rx audio
13(87,0,0)	T_TXMUTE_I	Mute tx audio
14(88,0,0)	T_TXUNMUTE_I	Unmute tx audio
15(89,1,0)	T_VOC_ESEC_I	Echo Canceller
16(8F,0,0)	T_STON_I	Turn on ST
17(90,0,0)	T_STOFF_I	Turn off ST
18(92,2,0)	T_LCD_CONTRAST_I	LCD contrast control
20(9E,3,0)	T_LNA_GAIN_WR_I	Write LNA gain for IMD test
21(9C,5,0)	T_TEST_SYS_I	Set test system & channel
22(91,96,96)	T_SNDNAM_I	Display and send NARI information.
23(95,3,4)	T_SNDVERSION_I	Display and return s/w version
24(9F,7,8)	T_SNDESN_I	Display and return ESN
25(92,0,0)	T_BACKLIGHT_ON_I	Turn on the backlight
26(93,0,0)	T_BACKLIGHT_OFF_I	Turn off the backlight
27(96,0,0)	T_DATASVC_ON_I	Turn on the LED
28(97,0,0)	T_DATASVC_OFF_I	Turn off the LED
30(9D,15,0)	T_PLINE_I	Display and return production date
31(00,1,0)	T_AUTO_ANSWER_I	Enable auto-answer mode
32(A0,1,0)	T_SATON_I	Turn on SAT
33(A1,0,0)	T_SATOFF_I	Turn off SAT
31(A2,0,0)	T_CDATA_I	Continuously send TX control data

38(A6.3.0)	T_VOC_ENC_OFFSET_I	Vocoder ENC offset
39(A7.3.0)	T_VOC_DEC_OFFSET_I	Vocoder DEC offset
40(A7.3.0)	T_VOC_CDMA_UNITY_GAIN_I	Vocoder CDhIA unity gain
42(AA.1.0)	T_DTMFON_I	Turn on DTMF
43(AB.0.0)	T_DTMFOFF_I	Turn off DTMF
44(B0.0.0)	T_COMPANDORON_I	Turn on compandor
45(B1.0.0)	T_COMPANDOROFF_I	Turn off compandor
48(B4.0.0)	T_VIBRATOR_ON_I	Activate a vibrator
49(B5.0.0)	T_VIBRATOR_OFF_I	Inactivate a vibrator
50(B6.0.4)	T_BATT_TYPE_I	Display Battery Type
52(B9.0.8)	T_HW_VERSION_I	Display H/W Version.
53(BA.3.0)	T-CARRIER-I	Target Carrier option
54(BB.7.8)	T_SNDPINFO_I	Send product information 8 character
55(AC.1.0)	T_EXT_AUDIO_I	External Audio Path on/off
57(BC.0.0)	T_MIC_ON_I	Mic path on
58(BD.0.0)	T_MIC_OFF_I	Mic path off
59(BE.0.0)	T_ALLPATH_I	Turn on the all audio path
67(C6.3.6)	T_READ_BATT_I	Display Battery Voltage Level
68(C8.0.3)	T_VBATT1_I	Set the low battery position in the standby
69(C9.0.3)	T_VBATT2_I	Set the low battery position in the talking
70(CA.3.0)	T_WRITE_BATT_I	Write low battery Level Value to NVM
71(D1.3.0)	T_CDMA_TXADJ_I	Set tx_agc_adj for CDhIA mode
73(D3.1.0)	T_SET_PA_R_I	Set PA R1,R0 range bits
74(D4.4.0)	T_TXRAS_ADJ_I	Set CDhIA Tx RAS Table
75(D5.0.3)	T_READ_RSSI_I	Read a RSSI and Adjust Rx RSSI
76(D6.3.0)	T_WRITE_RSSI_I	Write Rx RSSI Adjust Value(Just for Auto Test)
77(D7.0.3)	T_READ_TEMP_I	Read Temperature code
78(D8.0.3)	T_RXRAS_AUTO_I	Calcurate Rx RAS table(Just for Auto Test)
79(D9.1.0)	T_BUZZER_ON_I	Buzzer On
80(DA.0.0)	T_BUZZER_OFF_I	Buzzer OFF
81(E3.0.0)	T_VOC_PCMLPON_I	Play a PCM LOOP BACK
82(E4.0.0)	T_VOC_PCMLPOFF_I	Play off a PCM LOOP BACK
85(E7.0.0)	T_SPEAKER_ON_I	Turn on the speaker path
86(E8.0.0)	T_SPEAKER_OFF_I	Turn off the speaker path
89(EB.3.0)	T_CDTRK_ADJ_I	CDMA TRK local adjust
93(F3.1.0)	T_CDM IA-TEST-1	CDMA test
96(F6.4.0)	T_CH_FLATNESS_I	Adjust TX high power RAS
99(FC.1.0)	T_SND_GAIN_I	Mic/Speaker gain control