



# PCTEST ENGINEERING LABORATORY, INC.

6660-B Dobbin Road, Columbia, MD 21045 USA  
Tel. +1.410.290.6652 / Fax +1.410.290.6654  
<http://www.pctestlab.com>



## SAR COMPLIANCE EVALUATION REPORT

**Applicant Name:**  
Samsung Electronics, Co. Ltd.  
18600 Broadwick St.  
Rancho Dominguez, CA 90220  
United States

**Date of Testing:**  
05/02/11 - 05/04/11  
**Test Site/Location:**  
PCTEST Lab, Columbia, MD, USA  
**Test Report Serial No.:**  
0Y1104190774-R1.A3L

**FCC ID:** A3LSCHI905

**APPLICANT:** SAMSUNG ELECTRONICS, CO. LTD.

**EUT Type:** Cellular/PCS CDMA/EVDO and LTE Tablet with Bluetooth and WLAN  
**Application Type:** Certification  
**FCC Rule Part(s):** CFR §2.1093; FCC/OET Bulletin 65 Supplement C [June 2001]  
**Model(s):** SCH-I905  
**Tx Frequency:** 782 MHz (LTE)  
824.70 - 848.31 MHz (Cellular CDMA) / 1851.25 - 1908.75 MHz (PCS CDMA)  
2412 - 2462 MHz (WLAN 802.11b/g/n)  
5180 - 5240 MHz (WLAN 802.11a/n) / 5260 - 5320 MHz (WLAN 802.11a/n)  
5500 - 5700 MHz (WLAN 802.11 a/n) / 5745 - 5825 MHz (WLAN 802.11a/n)  
**Conducted Power:** 23.00 dBm LTE  
24.33 dBm Cell. CDMA / 24.47 dBm PCS CDMA  
13.30 dBm 2.4 GHz WLAN  
12.57 dBm 5.2 GHz WLAN / 13.01 dBm 5.3 GHz WLAN  
12.83 dBm 5.5 GHz WLAN / 13.32 dBm 5.8 GHz WLAN  
**Max. SAR Measurement:** 1.05 W/kg LTE Body SAR  
0.67 W/kg Cell. CDMA Body SAR / 0.76 W/kg PCS CDMA Body SAR  
1.18 W/kg 2.4 GHz WLAN Body SAR  
0.26 W/kg 5.2 GHz WLAN Body SAR / 0.29 W/kg 5.3 GHz WLAN Body SAR  
0.65 W/kg 5.5 GHz WLAN Body SAR / 0.72 W/kg 5.8 GHz WLAN Body SAR  
**Test Device Serial No.:** Pre-Production [S/N: FCC #1, FCC #2, FCC #3]

**Note:** This revised Test Report (S/N: 0Y1104190774-R1.A3L) supersedes and replaces the previously issued test report on the same subject EUT for the same type of testing as indicated. Please discard or destroy the previously issued test report and dispose of it accordingly.

This wireless portable device has been shown to be capable of compliance for localized specific absorption rate (SAR) for uncontrolled environment/general population exposure limits specified in ANSI/IEEE C95.1-1992 and has been tested in accordance with the measurement procedures specified in FCC/OET Bulletin 65 Supplement C (2001), IEEE 1528-2003 and in applicable Industry Canada Radio Standards Specifications (RSS); for North American frequency bands only.

I attest to the accuracy of data. All measurements reported herein were performed by me or were made under my supervision and are correct to the best of my knowledge and belief. I assume full responsibility for the completeness of these measurements and vouch for the qualifications of all persons taking them. Test results reported herein relate only to the item(s) tested.

PCTEST certifies that no party to this application has been subject to a denial of Federal benefits that includes FCC benefits pursuant to Section 5301 of the Anti-Drug Abuse Act of 1988, 21 U.S.C. 862.

Randy Ortanez  
President



<b>FCC ID:</b> A3LSCHI905		<b>SAR COMPLIANCE REPORT</b>		<b>Reviewed by:</b> Quality Manager
<b>Filename:</b> 0Y1104190774-R1.A3L	<b>Test Dates:</b> 05/02/11 - 05/04/11	<b>EUT Type:</b> Cellular/PCS CDMA/EVDO and LTE Tablet with Bluetooth and WLAN		Page 1 of 50

# 1

# LTE SPECIFICATIONS PER KDB 941225

KDB 941225 Pub LTE Information				
	<b>FCC ID</b>	<b>A3LSCHI905</b>		
	Form Factor	10.1" LCD Color Tablet		
1)	Frequency Range of each LTE transmission band	Band 13: 782 MHz		
2)	Channel Bandwidths	10 MHz BW		
3)	H, M, L channel numbers and frequencies			
	Band 13	Low	Mid	High
	10MHz BW:	NA	782 MHz (CH:23230)	NA
4)(a)	UE Category	3		
(b)	Modulations Supported in UL	QPSK, 16QAM		
	LTE Transmitter and Antenna Implementation	See Operational Description		
5)	Description of LTE Tx and Ant. Implementation	1 TX/RX Antenna and 1 Rx Antenna		
6)	LTE Voice over IMS available?	No		
	Hotspot with LTE+WIFI	Yes		
	Hotspot with LTE+WIFI active with 1XVoice sessions?	No		
7)	LTE MPR Permanently implemented per 3GPP TS 36.101 section 6.2.3~6.2.5? (manufacturer attestation to be provided)	Yes		
	A-MPR (Additional MPR) disabled for SAR Testing?	Yes		
8)	Conducted power Table provided for 1RB (low and high offset), 50% RB (centered), 100% RB	Yes		
9-10)	Non-LTE US Wireless Operating Modes/Band	RF Output Power	RF Exposure Configurations	
	835 MHz CDMA	24.33 dBm	Body	
	1900 MHz CDMA	24.47 dBm	Body	
	2.4 GHz Bluetooth	8.81 dBm	Body	
	2.4 GHz WI-FI	13.30 dBm	Body	
	5 GHz WI-FI	13.32 dBm	Body	
11)	Simultaneous Tx conditions	See Section 17 of the SAR Report		
12)	Power Reduction used for SAR Compliance?	Yes		
13)	Description of SAR Test	See Section 16		
14)	SAR Test Plan Proposal	Discussed in KDB inquiry 450108 & April 2011 TCB-Workshop Notes		
15)	SAR Test Data for Power Reduction	Power Reduction only for proximity sensors. See Section 16		

<b>FCC ID:</b> A3LSCHI905		<b>SAR COMPLIANCE REPORT</b>		<b>Reviewed by:</b> Quality Manager
<b>Filename:</b> OY1104190774-R1.A3L	<b>Test Dates:</b> 05/02/11 - 05/04/11	<b>EUT Type:</b> Cellular/PCS CDMA/EVDO and LTE Tablet with Bluetooth and WLAN		Page 2 of 50

# T A B L E O F C O N T E N T S

---

1	LTE SPECIFICATIONS PER KDB 941225 .....	2
2	INTRODUCTION .....	4
3	TEST SITE LOCATION .....	5
4	SAR MEASUREMENT SETUP .....	6
5	DASY E-FIELD PROBE SYSTEM .....	8
6	PROBE CALIBRATION PROCESS .....	9
7	PHANTOM AND EQUIVALENT TISSUES.....	10
8	DOSIMETRIC ASSESSMENT & PHANTOM SPECS.....	12
9	FCC RF EXPOSURE LIMITS.....	13
10	ANTENNA LOCATIONS AND KEY FEATURES .....	14
11	SAR TESTING CONSIDERATIONS & FCC KDB INQUIRIES .....	16
12	FCC 3G MEASUREMENT PROCEDURES.....	24
13	SAR TESTING WITH IEEE 802.11 TRANSMITTERS.....	27
14	4G LTE TEST CONFIGURATIONS .....	30
15	SYSTEM VERIFICATION.....	32
16	SAR DATA SUMMARY .....	34
17	SIMULTANEOUS TRANSMISSION ANALYSIS.....	39
18	EQUIPMENT LIST.....	40
19	MEASUREMENT UNCERTAINTIES .....	41
20	CONCLUSION.....	43
21	REFERENCES .....	44
22	SAR TEST SETUP PHOTOGRAPHS.....	46

<b>FCC ID:</b> A3LSCHI905		<b>SAR COMPLIANCE REPORT</b>		<b>Reviewed by:</b> Quality Manager
<b>Filename:</b> 0Y1104190774-R1.A3L	<b>Test Dates:</b> 05/02/11 - 05/04/11	<b>EUT Type:</b> Cellular/PCS CDMA/EVDO and LTE Tablet with Bluetooth and WLAN		Page 3 of 50

## 2 INTRODUCTION

The FCC has adopted the guidelines for evaluating the environmental effects of radio frequency (RF) radiation in ET Docket 93-62 on Aug. 6, 1996 to protect the public and workers from the potential hazards of RF emissions due to FCC-regulated portable devices. [1]

The safety limits used for the environmental evaluation measurements are based on the criteria published by the American National Standards Institute (ANSI) for localized specific absorption rate (SAR) in IEEE/ANSI C95.1-1992 Standard for Safety Levels with Respect to Human Exposure to Radio Frequency Electromagnetic Fields, 3 kHz to 300 GHz [3] and Health Canada RF Exposure Guidelines Safety Code 6 [24]. The measurement procedure described in IEEE/ANSI C95.3-2002 Recommended Practice for the Measurement of Potentially Hazardous Electromagnetic Fields - RF and Microwave [4] is used for guidance in measuring the Specific Absorption Rate (SAR) due to the RF radiation exposure from the Equipment Under Test (EUT). These criteria for SAR evaluation are similar to those recommended by the International Committee for Non-Ionizing Radiation Protection (ICNIRP) in "Biological Effects and Exposure Criteria for Radiofrequency Electromagnetic Fields," Report No. Vol 74. SAR is a measure of the rate of energy absorption due to exposure to an RF transmitting source. SAR values have been related to threshold levels for potential biological hazards.

### 2.1 SAR Definition

Specific Absorption Rate is defined as the time derivative (rate) of the incremental energy (dU) absorbed by (dissipated in) an incremental mass (dm) contained in a volume element (dV) of a given density ( $\rho$ ). It is also defined as the rate of RF energy absorption per unit mass at a point in an absorbing body (see Fig. 1-1).

$$SAR = \frac{d}{dt} \left( \frac{dU}{dm} \right) = \frac{d}{dt} \left( \frac{dU}{\rho dv} \right)$$

Figure 2-1  
SAR Mathematical Equation



SAR is expressed in units of Watts per Kilogram (W/kg).

$$SAR = \frac{\sigma \cdot E^2}{\rho}$$

where:

- $\sigma$  = conductivity of the tissue-simulating material (S/m)
- $\rho$  = mass density of the tissue-simulating material ( $\text{kg/m}^3$ )
- E = Total RMS electric field strength (V/m)

NOTE: The primary factors that control rate of energy absorption were found to be the wavelength of the incident field in relation to the dimensions and geometry of the irradiated organism, the orientation of the organism in relation to the polarity of field vectors, the presence of reflecting surfaces, and whether conductive contact is made by the organism with a ground plane.[6]

FCC ID: A3LSCHI905	 PCTEST ENGINEERING LABORATORY, INC.	SAR COMPLIANCE REPORT		Reviewed by: Quality Manager
Filename: 0Y1104190774-R1.A3L	Test Dates: 05/02/11 - 05/04/11	EUT Type: Cellular/PCS CDMA/EVDO and LTE Tablet with Bluetooth and WLAN		Page 4 of 50

### 3 TEST SITE LOCATION

#### 3.1 INTRODUCTION

The map at the right shows the location of the PCTEST LABORATORY in Columbia, Maryland. It is in proximity to the FCC Laboratory, the Baltimore-Washington International (BWI) airport, the city of Baltimore and Washington, DC.

These measurement tests were conducted at the PCTEST Engineering Laboratory, Inc. facility in New Concept Business Park, Guilford Industrial Park, Columbia, Maryland. The site address is 6660-B Dobbin Road, Columbia, MD 21045. The test site is one of the highest points in the Columbia area with an elevation of 390 feet above mean sea level. The site coordinates are 39° 11'15" N latitude and 76° 49' 38" W longitude. The facility is 1.5 miles north of the FCC laboratory, and the ambient signal and ambient signal strength are approximately equal to those of the FCC laboratory. There are no FM or TV transmitters within 15 miles of the site. The detailed description of the measurement facility was found to be in compliance with the requirements of § 2.948 according to ANSI C63.4 on January 27, 2006 and Industry Canada.





**Figure 3-1**  
Map of the Greater Baltimore and Metropolitan Washington, D.C. area

#### 3.2 Test Facility / Accreditations:

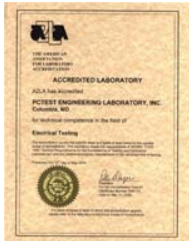
Measurements were performed at an independent accredited PCTEST Engineering Lab located in Columbia, MD 21045, U.S.A.



- PCTEST Lab is accredited to ISO 17025-2005 by the American Association for Laboratory Accreditation (A2LA) in Specific Absorption Rate (SAR) testing, Hearing-Aid Compatibility (HAC), Battery Safety, CTIA Test Plans, and wireless testing for FCC and Industry Canada Rules.
- PCTEST Lab is accredited to ISO 17025 by U.S. National Institute of Standards and Technology (NIST) under the National Voluntary Laboratory Accreditation Program (NVLAP Lab code: 100431-0) in EMC, FCC and Telecommunications.
- PCTEST facility is an FCC registered (PCTEST Reg. No. 90864) test facility with the site description report on file and has met all the requirements specified in Section 2.948 of the FCC Rules and Industry Canada (IC-2451).
- PCTEST Lab is a recognized U.S. Conformity Assessment Body (CAB) in EMC and R&TTE (n.b. 0982) under the U.S.-EU Mutual Recognition Agreement (MRA).
- PCTEST TCB is a Telecommunication Certification Body (TCB) accredited to ISO/IEC Guide 65 by the American National Standards Institute (ANSI) in all scopes of FCC Rules and all Industry Canada Standards (RSS).
- PCTEST facility is an IC registered (IC-2451) test laboratory with the site description on file at Industry Canada.
- PCTEST is a CTIA Authorized Test Laboratory (CATL) for AMPS and CDMA, and EvDO mobile phones.
- PCTEST is a CTIA Authorized Test Laboratory (CATL) for Over-the-Air (OTA) Antenna Performance testing for AMPS, CDMA, GSM, GPRS, EGPRS, UMTS (W-CDMA), CDMA 1xEVDO Data, CDMA 1xRTT Data

<b>FCC ID:</b> A3LSCHI905		<b>SAR COMPLIANCE REPORT</b>		<b>Reviewed by:</b> Quality Manager
<b>Filename:</b> OY1104190774-R1.A3L	<b>Test Dates:</b> 05/02/11 - 05/04/11	<b>EUT Type:</b> Cellular/PCS CDMA/EVDO and LTE Tablet with Bluetooth and WLAN		Page 5 of 50

## 4 SAR MEASUREMENT SETUP

### 4.1 Robotic System

Measurements are performed using the DASY4 automated dosimetric assessment system. The DASY4 is made by Schmid & Partner Engineering AG (SPEAG) in Zurich, Switzerland and consists of a high precision robotics system (Staubli), robot controller, desktop computer, near-field probe, probe alignment sensor, and the SAM phantom containing the head or body equivalent material. The robot is a six-axis industrial robot, performing precise movements to position the probe to the location (points) of maximum electromagnetic field (EMF) (see Figure 4-1).

### 4.2 System Hardware

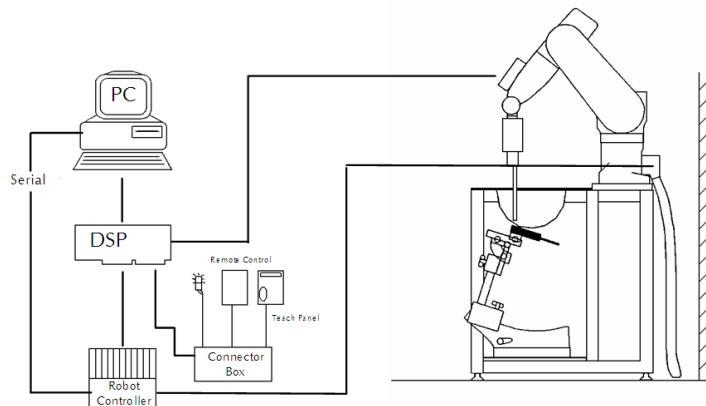

A cell controller system contains the power supply, robot controller, teach pendant (Joystick), and a remote control used to drive the robot motors. The PC consists of the SAR Measurement Software DASY4, A/D interface card, monitor, mouse, and keyboard. The Staubli Robot is connected to the cell controller to allow software manipulation of the robot. A data acquisition electronic (DAE) circuit that performs the signal amplification, signal multiplexing, A/D conversion, offset measurements, mechanical surface detection, collision detection, etc. is connected to the Electro-optical coupler (EOC). The EOC performs the conversion from the optical into digital electric signal from the DAE and transfers data to the PC card.

### 4.3 System Electronics



**Figure 4-1**  
**SAR Measurement System Setup**

The DAE consists of a highly sensitive electrometer-grade auto-zeroing preamplifier, a channel and gain-switching multiplexer, a fast 16 bit AD-converter and a command decoder and control logic unit. Transmission to the PC-card is accomplished through an optical downlink for data and status information and an optical uplink for commands and clock lines. The mechanical probe mounting device includes two different sensor systems for frontal and sidewise probe contacts. They are also used for mechanical surface detection and probe collision detection. The robot uses its own controller with a built in VME-bus computer.

FCC ID: A3LSCHI905	 PCTEST ENGINEERING LABORATORY, INC.	SAR COMPLIANCE REPORT		Reviewed by: Quality Manager
Filename: 0Y1104190774-R1.A3L	Test Dates: 05/02/11 - 05/04/11	EUT Type: Cellular/PCS CDMA/EVDO and LTE Tablet with Bluetooth and WLAN		Page 6 of 50

## 4.4 Automated Test System Specifications

Test Software: SPEAG DASY4 version 4.7 Measurement Software  
 Robot: Stäubli Unimation Corp. Robot RX60L  
 Repeatability: 0.02 mm  
 No. of Axes: 6

Data Acquisition Electronic System (DAE)

Data Converter

Features: Signal Amplifier, multiplexer, A/D converter & control logic  
 Software: SEMCAD software  
 Connecting Lines: Optical Downlink for data and status info  
 Optical upload for commands and clock

PC Interface Card

Function: Link to DAE  
 16-bit A/D converter for surface detection system  
 Two Serial & Ethernet link to robotics  
 Direct emergency stop output for robot

Phantom

Type: SAM Twin Phantom (V4.0)  
 Shell Material: Composite  
 Thickness:  $2.0 \pm 0.2$  mm



**Figure 4-2**  
**SAR Measurement System**

FCC ID: A3LSCHI905		SAR COMPLIANCE REPORT		Reviewed by: Quality Manager
Filename: 0Y1104190774-R1.A3L	Test Dates: 05/02/11 - 05/04/11	EUT Type: Cellular/PCS CDMA/EVDO and LTE Tablet with Bluetooth and WLAN		Page 7 of 50

### 5.1 Probe Measurement System



**Figure 5-1  
SAR System**

The SAR measurements were conducted with the dosimetric probe designed in the classical triangular configuration (see Figure 5-3) and optimized for dosimetric evaluation [9]. The probe is constructed using the thick film technique; with printed resistive lines on ceramic substrates. The probe is equipped with an optical multi-fiber line ending at the front of the probe tip. It is connected to the EOC box on the robot arm and provides an automatic detection of the phantom surface. Half of the fibers are connected to a pulsed infrared transmitter, the other half to a synchronized receiver. As the probe approaches the surface, the reflection from the surface produces a coupling from the transmitting to the receiving fibers. This reflection increases first during the approach, reaches maximum and then decreases. If the probe is flatly touching the surface, the coupling is zero. The distance of the coupling maximum to the surface is independent of the surface reflectivity and largely independent of the surface to probe angle. The DASY4 software reads the reflection during a software approach and looks for the

maximum using a 2nd order curve fitting (see Figure 6-1). The approach is stopped at reaching the maximum.

### 5.2 Probe Specifications

<b>Model(s):</b>	ES3DV2, ES3DV3, EX3DV4
<b>Frequency Range:</b>	10 MHz – 6.0 GHz (EX3DV4) 10 MHz – 4 GHz (ES3DV3)
<b>Calibration:</b>	In head and body simulating tissue at Frequencies from 300 up to 6000MHz
<b>Linearity:</b>	± 0.2 dB (30 MHz to 6 GHz) for EX3DV4 ± 0.2 dB (30 MHz to 4 GHz) for ES3DV3
<b>Dynamic Range:</b>	10 mW/kg – 100 W/kg
<b>Probe Length:</b>	330 mm
<b>Probe Tip Length:</b>	20 mm
<b>Body Diameter:</b>	12 mm
<b>Tip Diameter:</b>	2.5 mm (3.9mm for ES3DV3)
<b>Tip-Center:</b>	1 mm (2.0 mm for ES3DV3)
<b>Application:</b>	SAR Dosimetry Testing Compliance tests of mobile phones Dosimetry in strong gradient fields



**Figure 5-2  
Near-Field Probe**



**Figure 5-3  
Triangular Probe  
Configuration**

FCC ID: A3LSCHI905	 PCTEST ENGINEERING LABORATORY, INC.	SAR COMPLIANCE REPORT		Reviewed by: Quality Manager
Filename: 0Y1104190774-R1.A3L	Test Dates: 05/02/11 - 05/04/11	EUT Type: Cellular/PCS CDMA/EVDO and LTE Tablet with Bluetooth and WLAN		Page 8 of 50

# 6 PROBE CALIBRATION PROCESS

## 6.1 Dosimetric Assessment Procedure

Each E-Probe/Probe Amplifier combination has unique calibration parameters. A TEM cell calibration procedure is conducted to determine the proper amplifier settings to enter in the probe parameters. The amplifier settings are determined for a given frequency by subjecting the probe to a known E-field density (1 mW/cm<sup>2</sup>) using an RF Signal generator, TEM cell, and RF Power Meter.

## 6.2 Free Space Assessment

The free space E-field from amplified probe outputs is determined in a test chamber. This calibration can be performed in a TEM cell if the frequency is below 1 GHz and in a waveguide or other methodologies above 1 GHz for free space. For the free space calibration, the probe is placed in the volumetric center of the cavity and at the proper orientation with the field. The probe is rotated 360 degrees until the three channels show the maximum reading. The power density readings equates to 1 mW/cm<sup>2</sup>.

## 6.3 Temperature Assessment

E-field temperature correlation calibration is performed in a flat phantom filled with the appropriate simulated head tissue. The E-field in the medium correlates with the temperature rise in the dielectric medium. For temperature correlation calibration a RF transparent thermistor-based temperature probe is used in conjunction with the E-field probe.

$$SAR = C \frac{\Delta T}{\Delta t}$$

where:

- $\Delta t$  = exposure time (30 seconds),
- C = heat capacity of tissue (brain or muscle),
- $\Delta T$  = temperature increase due to RF exposure.

$$SAR = \frac{|E|^2 \cdot \sigma}{\rho}$$

where:

- $\sigma$  = simulated tissue conductivity,
- $\rho$  = Tissue density (1.25 g/cm<sup>3</sup> for brain tissue)

SAR is proportional to  $\Delta T/\Delta t$ , the initial rate of tissue heating, before thermal diffusion takes place. The electric field in the simulated tissue can be used to estimate SAR by equating the thermally derived SAR to that with the E- field component.

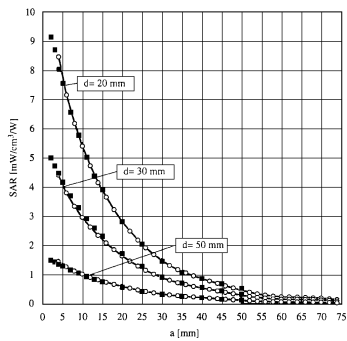

Figure 6-1 E-Field and Temperature measurements at 900MHz [9]

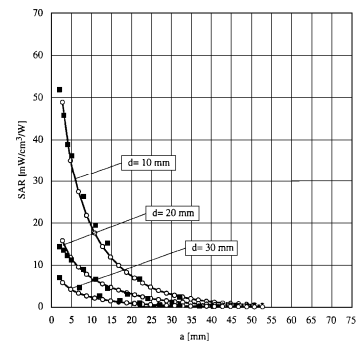

Figure 6-2 E-Field and temperature measurements at 1.9GHz [9]

FCC ID: A3LSCHI905		SAR COMPLIANCE REPORT		Reviewed by: Quality Manager
Filename: 0Y1104190774-R1.A3L	Test Dates: 05/02/11 - 05/04/11	EUT Type: Cellular/PCS CDMA/EVDO and LTE Tablet with Bluetooth and WLAN		Page 9 of 50

# 7 PHANTOM AND EQUIVALENT TISSUES

## 7.1 SAM Phantoms



**Figure 7-1  
SAM Phantoms**

The SAM Twin Phantom V4.0 is constructed of a fiberglass shell integrated in a table. The shape of the shell is based on data from an anatomical study designed to represent the 90<sup>th</sup> percentile of the population [12][13]. The phantom enables the dosimetric evaluation of SAR for both left and right handed handset usage, as well as body-worn usage using the flat phantom region. Reference markings on the Phantom allow the complete setup of all predefined phantom positions and measurement grids by manually teaching three points in the robot. The shell phantom has a 2mm shell thickness (except the ear region where shell thickness increases to 6 mm).

## 7.2 Tissue Simulating Mixture Characterization



**Figure 7-2  
SAM Phantom with  
Simulating Tissue**

The mixture is characterized to obtain proper dielectric constant (permittivity) and conductivity of the tissue of interest. The tissue dielectric parameters recommended in IEEE 1528 and IEC 62209 have been used as targets for the compositions, and are to match within 5%, per the FCC recommendations.

**Table 7-1**  
Composition of the Tissue Equivalent Matter

Frequency (MHz)	835	1900	2450	5200-5800
Tissue	Body	Body	Body	Body
Ingredients (% by weight)				
Bactericide	0.1			
DGBE		29.44	26.7	
HEC	1			
NaCl	0.94	0.39	0.1	
Sucrose	44.9			
Triton X-100				10.67
Diethylenglycol monohexylether				10.67
Water	53.06	70.17	73.2	78.66

Note: See next page for 750 MHz information

FCC ID: A3LSCHI905	 PCTEST ENGINEERING LABORATORY, INC.	SAR COMPLIANCE REPORT		Reviewed by: Quality Manager
Filename: OY1104190774-R1.A3L	Test Dates: 05/02/11 - 05/04/11	EUT Type: Cellular/PCS CDMA/EVDO and LTE Tablet with Bluetooth and WLAN		Page 10 of 50

**Table 7-2**  
Composition of the 750MHz Body Tissue Equivalent Matter

<b>2 Composition / Information on ingredients</b>	
The Item is composed of the following ingredients:	
H <sub>2</sub> O	Water, 35 – 58%
Sucrose	Sugar, white, refined, 40 – 60%
NaCl	Sodium Chloride, 0 – 6%
Hydroxyethyl-cellulose	Medium Viscosity (CAS# 9004-82-0), <0.3%
Preventol-D7	Preservative: aqueous preparation, (CAS# 55965-84-9), containing 5-chloro-2-methyl-3(2H)-isothiazolone and 2-methyl-3(2H)-isothiazolone, 0.1 – 0.7%
	Relevant for safety; Refer to the respective Safety Data Sheet <sup>®</sup> .

**Note:** 750MHz Body liquid recipe is proprietary SPEAG. The composition is approximate to the actual liquids utilized. Thus the manufacturer production sheet is provided below.

**Figure 7-1**  
750MHz Body Tissue Equivalent Matter

f [MHz]	HP-e'	HP-e''	sigma	P/N:	SL AAM 075	TARGET PARAMETERS		
300	61.02	35.43	0.59	Charge:	090224-1	f [MHz]	eps	sigma
350	60.21	32.13	0.63	Mea Date:	05-Mrz-09	700	55.7	0.96
400	59.50	29.71	0.66	Temp [°C]	22	750	55.5	0.96
450	58.79	28.00	0.70			800	55.3	0.97
500	58.16	26.60	0.74					
550	57.57	25.54	0.78					
600	56.99	24.68	0.82					
650	56.43	23.97	0.87					
700	55.88	23.46	0.91					
750	55.35	22.91	0.96					
800	55.02	22.56	1.00					
850	54.50	22.31	1.06					
900	54.02	22.08	1.11					
950	53.55	21.89	1.16					
1000	53.05	21.70	1.21					

FCC ID: A3LSCHI905	 PCTEST ENGINEERING LABORATORY, INC.	<b>SAR COMPLIANCE REPORT</b>		Reviewed by: Quality Manager
Filename: 0Y1104190774-R1.A3L	Test Dates: 05/02/11 - 05/04/11	EUT Type: Cellular/PCS CDMA/EVDO and LTE Tablet with Bluetooth and WLAN		Page 11 of 50

### 8.1 Measurement Procedure

The evaluation was performed using the following procedure:

1. The SAR distribution at the exposed side of the head was measured at a distance no greater than 5.0 mm from the inner surface of the shell. The area covered the entire dimension of the head and the horizontal grid spacing was 15mm x 15mm.
2. The point SAR measurement was taken at the maximum SAR region determined from Step 1 to enable the monitoring of SAR fluctuations/drifts during testing the 1 gram cube. This fixed point was measured and used as a reference value.
3. Based on the area scan data, the area of the maximum absorption was determined by spline interpolation. Around this point, a volume of 32mm x 32mm x 30mm (fine resolution volume scan, zoom scan) was assessed by measuring 5 x 5 x 7 points. On this basis of this data set, the spatial peak SAR value was evaluated with the following procedure (see references or the DASY manual for more details):
  - a. The data was extrapolated to the surface of the outer-shell of the phantom. The combined distance extrapolated was the combined distance from the center of the dipoles 2.7mm away from the tip of the probe housing plus the 1.2 mm distance between the surface and the lowest measuring point. The extrapolation was based on a least-squares algorithm. A polynomial of the fourth order was calculated through the points in the z-axis (normal to the phantom shell).
  - b. After the maximum interpolated values were calculated between the points in the cube, the SAR was averaged over the spatial volume (1g or 10g) using a 3D-Spline interpolation algorithm. The 3D-spline is composed of three one-dimensional splines with the "Not a knot" condition (in x, y, and z directions). The volume was then integrated with the trapezoidal algorithm. One thousand points (10 x 10 x 10) were obtained through interpolation, in order to calculate the averaged SAR.
  - c. All neighboring volumes were evaluated until no neighboring volume with a higher average value was found.
4. The SAR reference value, at the same location as step 2, was re-measured after the zoom scan was complete. If the value deviated by more than 5%, the evaluation was repeated.
5. For 5 GHz testing finer resolution zoom scans were performed as specified by FCC SAR Measurement Requirements for 3 – 6 GHz, KDB pub 865664. The 5 GHz zoom scan requires a minimum volume of 24mm x 24mm x 20mm and 7 x 7 x 11 points.

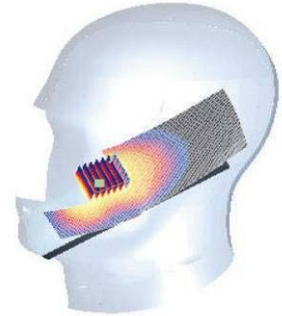



**Figure 8-1**  
Sample SAR Area Scan

### 8.2 Specific Anthropomorphic Mannequin (SAM) Specifications

The phantom for handset SAR assessment testing is a low-loss dielectric shell, with shape and dimensions derived from the anthropometric data of the 90th percentile adult male head dimensions as tabulated by the US Army. The SAM Twin Phantom shell is bisected along the mid-sagittal plane into right and left halves (see Figure 8-2). The perimeter sidewalls of each phantom halves are extended to allow filling with liquid to a depth that is sufficient to minimize reflections from the upper surface. The liquid depth is maintained at a minimum depth of 15 cm.



**Figure 8-2**  
SAM Twin Phantom Shell

FCC ID: A3LSCHI905	 <b>PCTEST</b> ENGINEERING LABORATORY, INC.	<b>SAR COMPLIANCE REPORT</b>		Reviewed by: Quality Manager
Filename: OY1104190774-R1.A3L	Test Dates: 05/02/11 - 05/04/11	EUT Type: Cellular/PCS CDMA/EVDO and LTE Tablet with Bluetooth and WLAN		Page 12 of 50

# 9 FCC RF EXPOSURE LIMITS

## 9.1 Uncontrolled Environment

UNCONTROLLED ENVIRONMENTS are defined as locations where there is the exposure of individuals who have no knowledge or control of their exposure. The general population/uncontrolled exposure limits are applicable to situations in which the general public may be exposed or in which persons who are exposed as a consequence of their employment may not be made fully aware of the potential for exposure or cannot exercise control over their exposure. Members of the general public would come under this category when exposure is not employment-related; for example, in the case of a wireless transmitter that exposes persons in its vicinity.



## 9.2 Controlled Environment

CONTROLLED ENVIRONMENTS are defined as locations where there is exposure that may be incurred by persons who are aware of the potential for exposure, (i.e. as a result of employment or occupation). In general, occupational/controlled exposure limits are applicable to situations in which persons are exposed as a consequence of their employment, who have been made fully aware of the potential for exposure and can exercise control over their exposure. This exposure category is also applicable when the exposure is of a transient nature due to incidental passage through a location where the exposure levels may be higher than the general population/uncontrolled limits, but the exposed person is fully aware of the potential for exposure and can exercise control over his or her exposure by leaving the area or by some other appropriate means.

**Table 9-1  
SAR Human Exposure Specified in ANSI/IEEE C95.1-1992 and Health Canada Safety Code 6**

HUMAN EXPOSURE LIMITS		
	UNCONTROLLED ENVIRONMENT <i>General Population</i> (W/kg) or (mW/g)	CONTROLLED ENVIRONMENT <i>Occupational</i> (W/kg) or (mW/g)
SPATIAL PEAK SAR Brain	1.6	8.0
SPATIAL AVERAGE SAR Whole Body	0.08	0.4
SPATIAL PEAK SAR Hands, Feet, Ankles, Wrists	4.0	20

1. The Spatial Peak value of the SAR averaged over any 1 gram of tissue (defined as a tissue volume in the shape of a cube) and over the appropriate averaging time.
2. The Spatial Average value of the SAR averaged over the whole body.
3. The Spatial Peak value of the SAR averaged over any 10 grams of tissue (defined as a tissue volume in the shape of a cube) and over the appropriate averaging time.

FCC ID: A3LSCHI905	 PCTEST ENGINEERING LABORATORY, INC.	SAR COMPLIANCE REPORT		Reviewed by: Quality Manager
Filename: 0Y1104190774-R1.A3L	Test Dates: 05/02/11 - 05/04/11	EUT Type: Cellular/PCS CDMA/EVDO and LTE Tablet with Bluetooth and WLAN		Page 13 of 50

# 10 ANTENNA LOCATIONS AND KEY FEATURES

## 10.1 Antennas and Key Feature Information

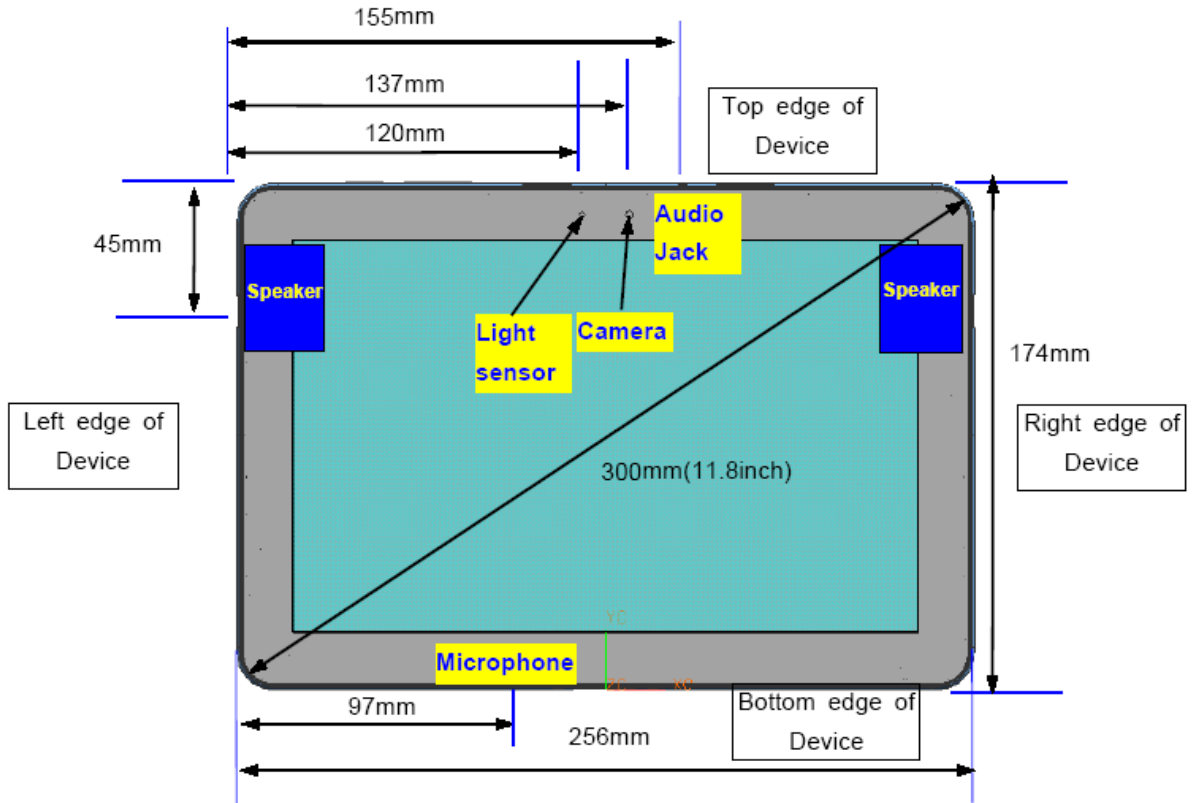

**Figure 10-1  
Front View of Device**

FCC ID: A3LSCHI905	PCTEST ENGINEERING LABORATORY, INC.	SAR COMPLIANCE REPORT	SAMSUNG	Reviewed by: Quality Manager
Filename: 0Y1104190774-R1.A3L	Test Dates: 05/02/11 - 05/04/11	EUT Type: Cellular/PCS CDMA/EVDO and LTE Tablet with Bluetooth and WLAN		Page 14 of 50

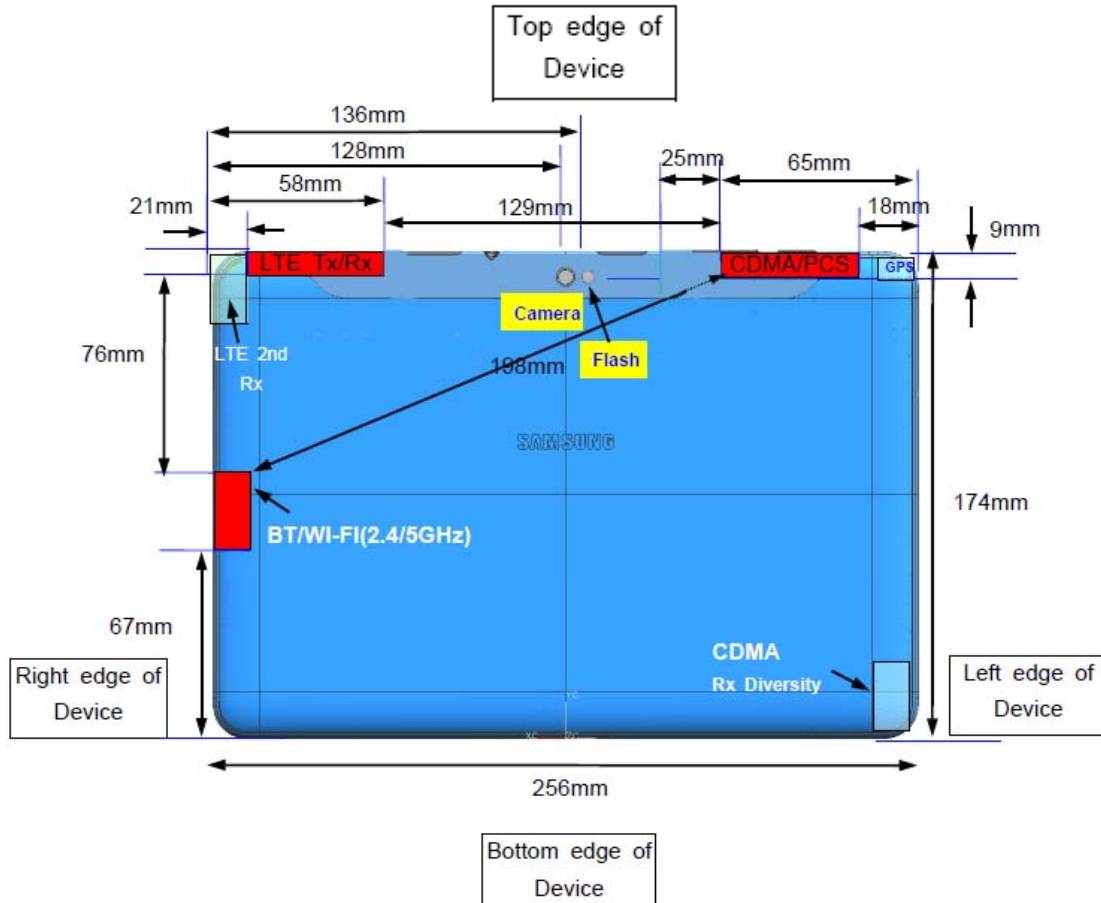

**Figure 10-2**  
**Back View of Device**



**Figure 10-3**  
**Top View of Device**

The operational description contains information about design including sensor sizes and locations. Note: Rear camera is not for video calls but for standard digital functions.

## 10.2 Proximity Sensor Information

The sensor pads are located near the upper half of the device to cover exposure conditions to the main antennas. The technical description contains information about sensor sizes and locations. Power reduction levels are provided in Section 11.3.

## 10.3 Display Orientations Capabilities

This device is capable of multiple display orientations supporting both portrait and landscape positions. Therefore per KDB Publication 447498 4) b) ii) (2), SAR testing applies for the tablet edges with antennas located within 5 cm of each tablet edge closest to the user (with KDB Publication 616217 applied to edges with antennas located 5 cm from the user). According to KDB Publication 447498 4) b) ii) (2), for each antenna, SAR is only required for the edge with the most conservative exposure condition.

FCC ID: A3LSCHI905	PCTEST ENGINEERING LABORATORY, INC.	SAR COMPLIANCE REPORT	SAMSUNG	Reviewed by: Quality Manager
Filename: 0Y1104190774-R1.A3L	Test Dates: 05/02/11 - 05/04/11	EUT Type: Cellular/PCS CDMA/EVDO and LTE Tablet with Bluetooth and WLAN		Page 15 of 50

# 11 SAR TESTING CONSIDERATIONS & FCC KDB INQUIRIES

## 11.1 Tablet testing for SAR

Lap-touching devices that have transmitting antennas located less than 20 cm from the lap of the user require routine SAR evaluation. Such devices are considered portable, and are capable of being held to the body. Devices are to be setup according to KDB 447498 requirements and are configured with maximum output power during SAR assessment for a worst-case SAR evaluation.

## 11.2 SAR Testing for Tablet per KDB 447498 Section 4

Per KDB 448498 4) b) i) the bottom face (back of the device) is required to be tested touching the flat phantom.

Per KDB 447498 4) b) ii) (2), SAR testing applies for the tablet edges with antennas located within 5 cm of each tablet edge closest to the user (with KDB 616217 applied to edges with antennas located  $\geq 5$  cm from the user). According to KDB 447498 4) b) ii) (2), for each antenna, SAR is only required for the edge with the most conservative exposure condition.

**Table 11-1 SAR Requirement Table per KDB pub 616217 D01**

Antenna Output Power (mW)	$\leq 60/f_{(GHz)}$	$> 60/f_{(GHz)}$
Individual Transmitter or Antenna	SAR not required	Antenna-to-user distance – $\geq (5 + \frac{1}{2} \cdot n)$ cm: test SAR on highest output channel only $< (5 + \frac{1}{2} \cdot n)$ cm: test SAR according to normal procedures
Simultaneous Transmitting Antennas	SAR not required: antenna-to-antenna or antenna-to-person distance $\geq 5$ cm	SAR not required: antenna-to-antenna $\geq (5 + \frac{1}{2} \cdot n_x + \frac{1}{2} \cdot n_y)$ and antenna-to-person $\geq (5 + \frac{1}{2} \cdot n_k)$ cm
	SAR not required: when $\sum (SAR_{1g}) < SAR$ limit, antenna-to-antenna distances $> 5$ cm and antenna-to-user distance $> 5$ cm if output $> 60/f$ otherwise, test antenna(s) using highest SAR configuration for the individual transmitter/antenna	

**Table 11-2 Distance Thresholds calculations KDB 616217 Publication**

Mode	Freq (GHz)	Power (mW)	60/f	$n=\{P/(60/f)\}-1$	distance thres ( $5+1/2n$ )
LTE Band 13	0.782	200	76.73	1.61	5.8
EVDO 835	0.835	271	71.86	2.77	6.4
EVDO 1900	1.88	280	31.91	7.77	8.9
WIFI b	2.462	21	24.37	-0.14	4.9
WIFI g	2.462	16	24.37	-0.34	4.8
WIFI n	2.462	17	24.37	-0.30	4.8
WIFI a	5.8	21	10.34	1.03	5.5
WIFI n	5.2	21	11.54	0.82	5.4

According to KDB 616217 publication and the antennas distance from the user to the edges of the device, the main WWAN antenna is required to be tested for SAR at the back and top edge of the device for all technologies as well as right edge for LTE and left edge for CDMA. The WLAN antenna is required to be tested for SAR at the back, and right edge of the device. Bottom edge for WLAN was also tested according to KDB 447498 4) b) ii) (2) since SAR is only required for the edges with the most conservative exposure condition.

Per KDB 447498 4) b) since the output power of the antenna is  $\leq 60/f$  (GHz), Bluetooth SAR is not required for both back side and edge exposure conditions.

FCC ID: A3LSCHI905	 <b>PCTEST</b> ENGINEERING LABORATORY, INC.	<b>SAR COMPLIANCE REPORT</b>		Reviewed by: Quality Manager
Filename: 0Y1104190774-R1.A3L	Test Dates: 05/02/11 - 05/04/11	EUT Type: Cellular/PCS CDMA/EVDO and LTE Tablet with Bluetooth and WLAN		Page 16 of 50

### 11.3 Additional SAR Testing for the Back and Top of the Device

Based on the type and implementation of the sensor, testing lab KDB Inquiry requires sensor information regarding: (1) additional SAR evaluation at a conservative distance from the device where power back-off is de-activated, and (2) reliability sensor activation data. Reliability sensor activation data is provided for both the back and top edge of the tablet at 0° to cover direct usage and also at 45° to cover angled usage (See Tables 11-3, 11-4, 11-5, and 11-6).

Since the back-off sensor de-activation distance at 45° was greater than 5 mm for the top edge for CDMA, a conservative distance of 5 mm was tested. Details about sensing mechanism and sensor location are included in the technical description.

The sensor is designed to support sufficient detection range and sensitivity to cover regions of the both antennas (CDMA and LTE) in all applicable directions per the manufacturer technical description.

**Table 11-3**  
**CDMA Distance from Back of Tablet**

distance in mm	9	10	11	12	13	14
Condition of Sensor in the back of the device	on	on	on	off	off	off

Please see Figure 11-1 and Figure 11-2 for power vs. back-off distance plots for CDMA and PCS modes.

**Backoff Sensor Power Reduction (back side)**

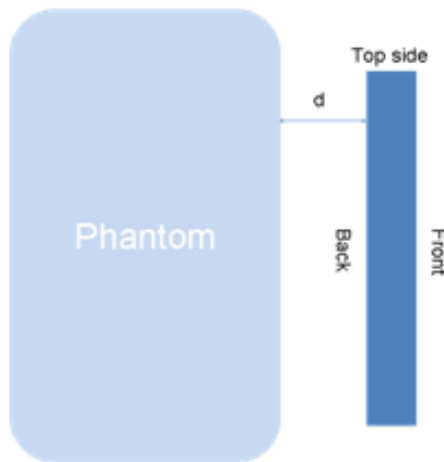

FCC ID: A3LSCHI905	 PCTEST ENGINEERING LABORATORY, INC.	SAR COMPLIANCE REPORT		Reviewed by: Quality Manager
Filename: 0Y1104190774-R1.A3L	Test Dates: 05/02/11 - 05/04/11	EUT Type: Cellular/PCS CDMA/EVDO and LTE Tablet with Bluetooth and WLAN		Page 17 of 50

## Backoff Sensor Power Reduction (Back side/CDMA)

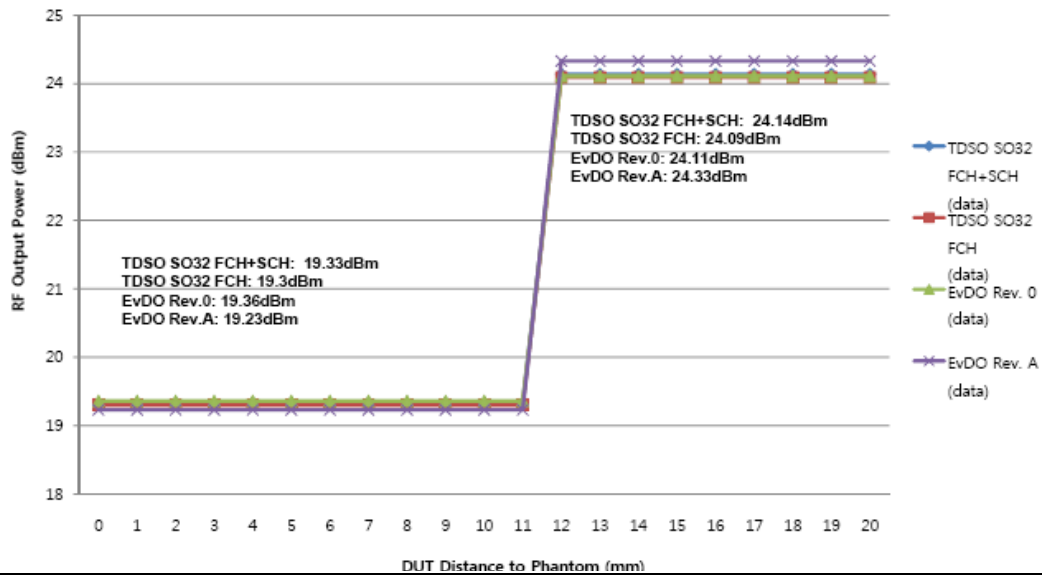

Figure 11-1

## CDMA Back off Power Reduction Graph – Back at 0° Angle

## Backoff Sensor Power Reduction (Back side/PCS)

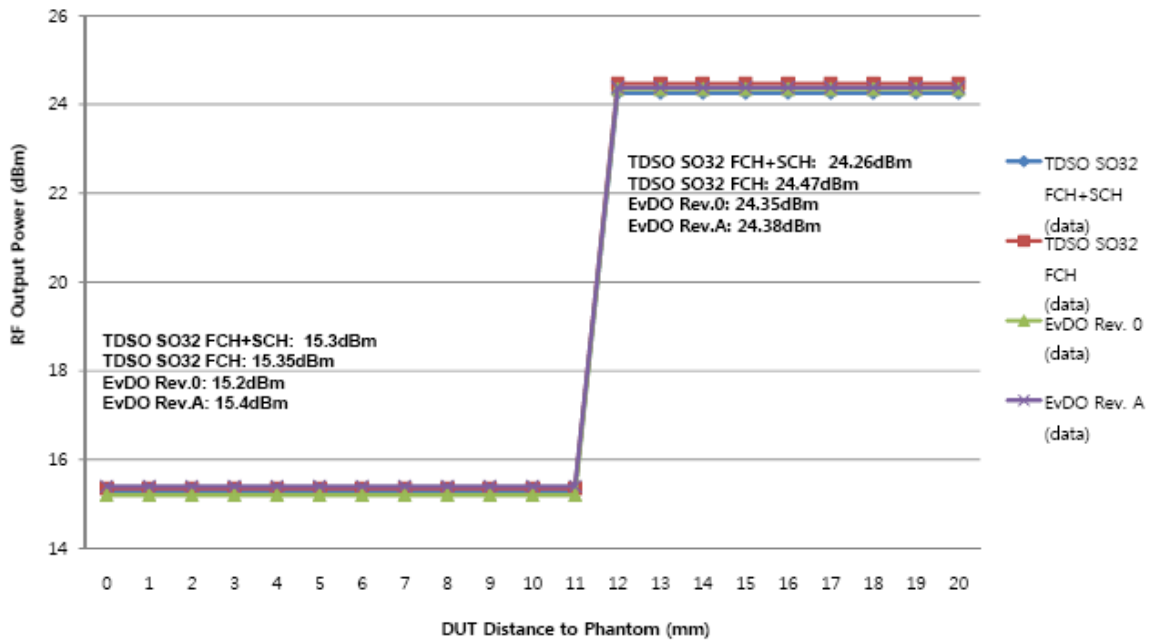

Figure 11-2

## PCS Back off Power Reduction Graph – Back at 0° Angle

FCC ID: A3LSCH1905	PCTEST ENGINEERING LABORATORY, INC.	SAR COMPLIANCE REPORT	SAMSUNG	Reviewed by: Quality Manager
Filename: 0Y1104190774-R1.A3L	Test Dates: 05/02/11 - 05/04/11	EUT Type: Cellular/PCS CDMA/EVDO and LTE Tablet with Bluetooth and WLAN		Page 18 of 50

**Table 11-4**  
**LTE Distance from Back of Tablet**

distance in mm	5	6	7	8	9	10
Condition of Sensor in the back of the device	on	off	off	off	off	off

Please see Figure 11-3 for power vs. back-off distance plots for LTE mode.

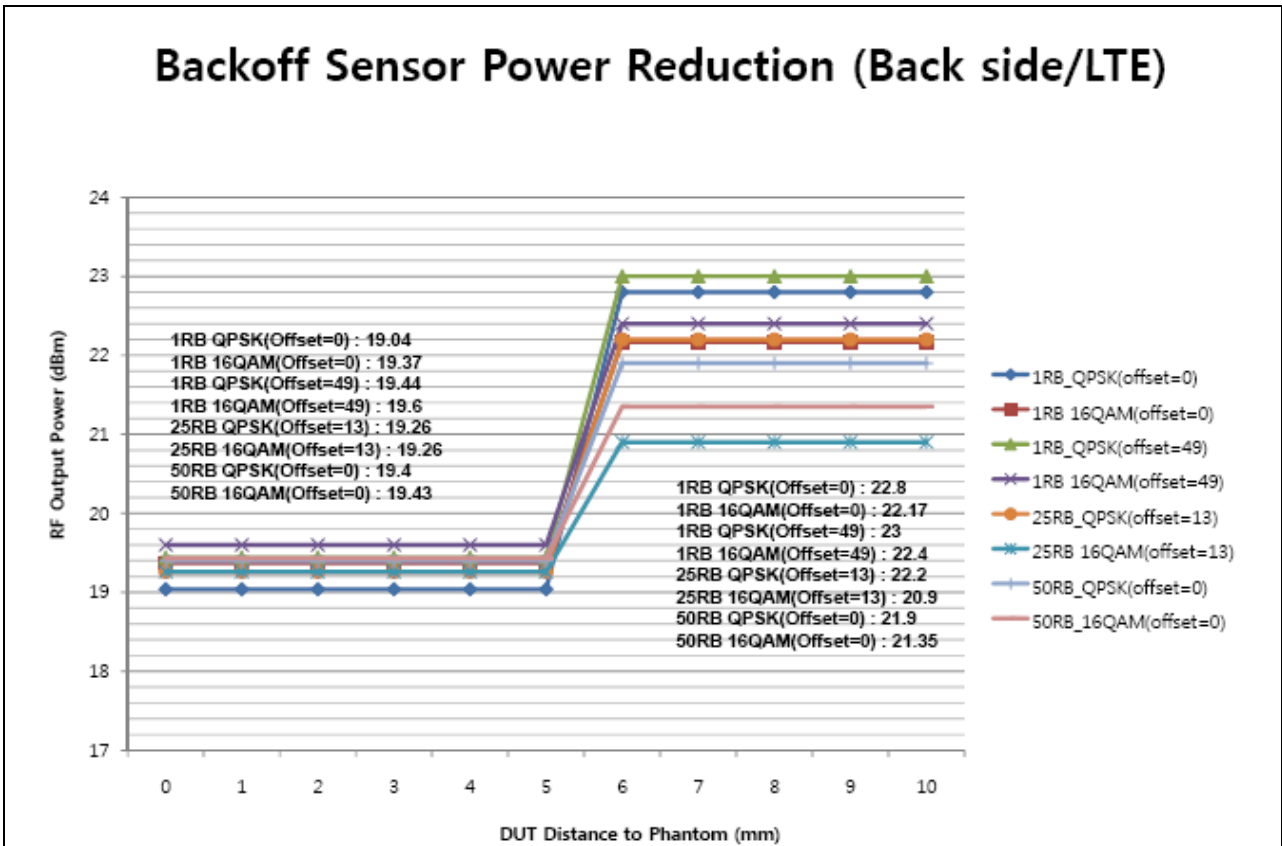

**Figure 11-3**  
**LTE Back off Power Reduction Graph – Back at 0° Angle**

FCC ID: A3LSCHI905		<b>SAR COMPLIANCE REPORT</b>		Reviewed by: Quality Manager
Filename: OY1104190774-R1.A3L	Test Dates: 05/02/11 - 05/04/11	EUT Type: Cellular/PCS CDMA/EVDO and LTE Tablet with Bluetooth and WLAN		Page 19 of 50

**Table 11-5 (CDMA)**  
**Distance from Top Edge of Tablet - 0° Angle**

distance in mm	5	6	7	8	9	10
Condition of Sensor in the back of the device	on	on	off	off	off	off

Please see Figure 11-4 and Figure 11-5 for power vs. back-off distance plots for each mode.

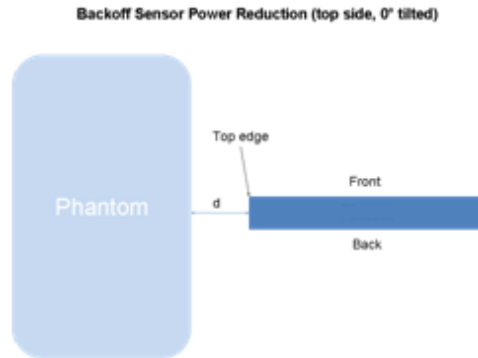

Note: Angle mentioned for top edge description is the perpendicular angle.  
 Above figure represents "0 degrees"

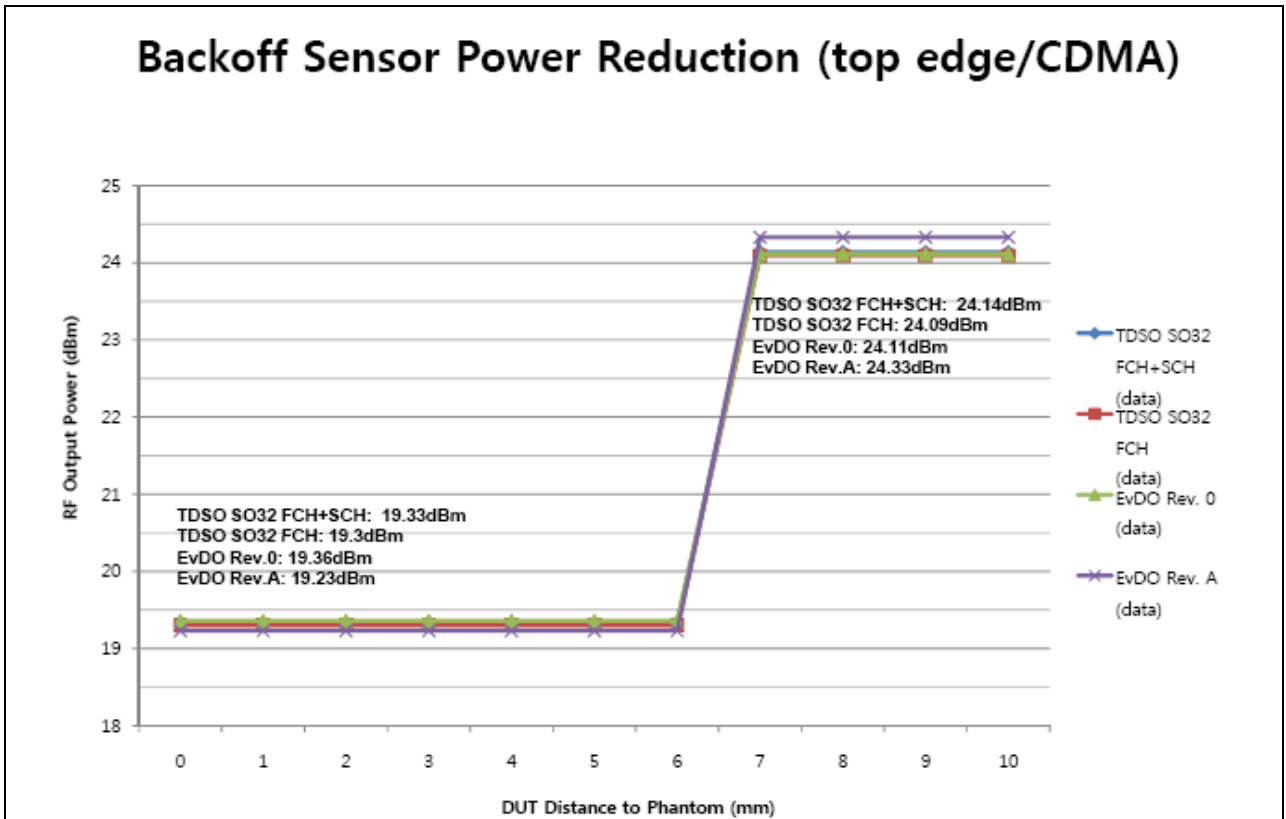

**Figure 11-4**  
**CDMA Back off Power Reduction Graph – Top at 0° Angle**

FCC ID: A3LSCHI905		SAR COMPLIANCE REPORT		Reviewed by: Quality Manager
Filename: 0Y1104190774-R1.A3L	Test Dates: 05/02/11 - 05/04/11	EUT Type: Cellular/PCS CDMA/EVDO and LTE Tablet with Bluetooth and WLAN	Page 20 of 50	

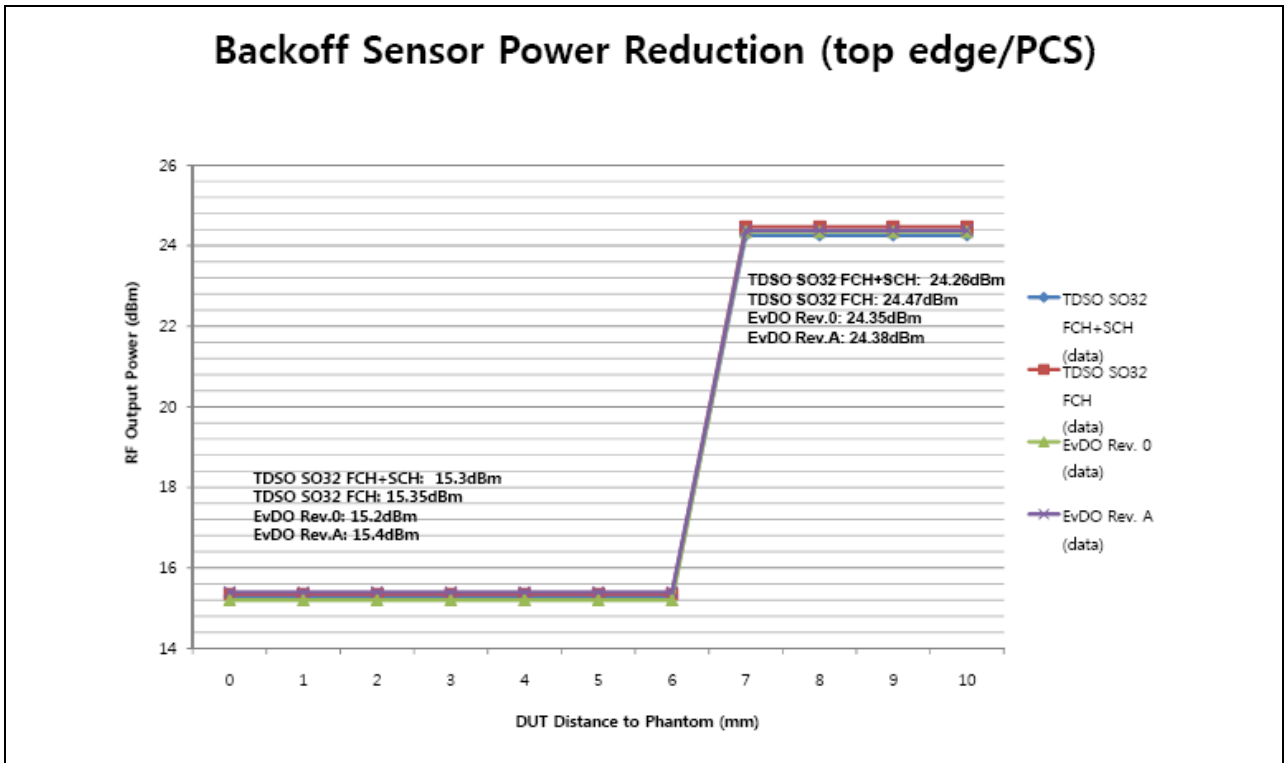
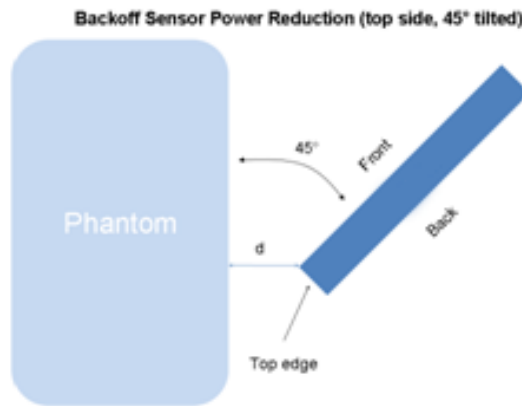

**Figure 11-5**  
**PCS Back off Power Reduction Graph – Top at 0° Angle**

**Table 11-6 (CDMA)**  
**Distance from Top of Tablet - 45° Angle**

distance in mm	5	6	7	8	9	10
Condition of Sensor in the back of the device	on	off	off	off	off	off

Please see Figure 11-7 and Figure 11-7 for power vs. back-off distance plots for each mode.



Note: Angle mentioned for top edge description is the perpendicular angle.  
 Above figure represents “45 degrees” between the screen face and phantom face.

<b>FCC ID:</b> A3LSCHI905	<b>PCTEST</b> ENGINEERING LABORATORY, INC.	<b>SAR COMPLIANCE REPORT</b>		<b>Reviewed by:</b> Quality Manager
<b>Filename:</b> OY1104190774-R1.A3L	<b>Test Dates:</b> 05/02/11 - 05/04/11	<b>EUT Type:</b> Cellular/PCS CDMA/EVDO and LTE Tablet with Bluetooth and WLAN		Page 21 of 50

## Backoff Sensor Power Reduction (45° tilted/CDMA)

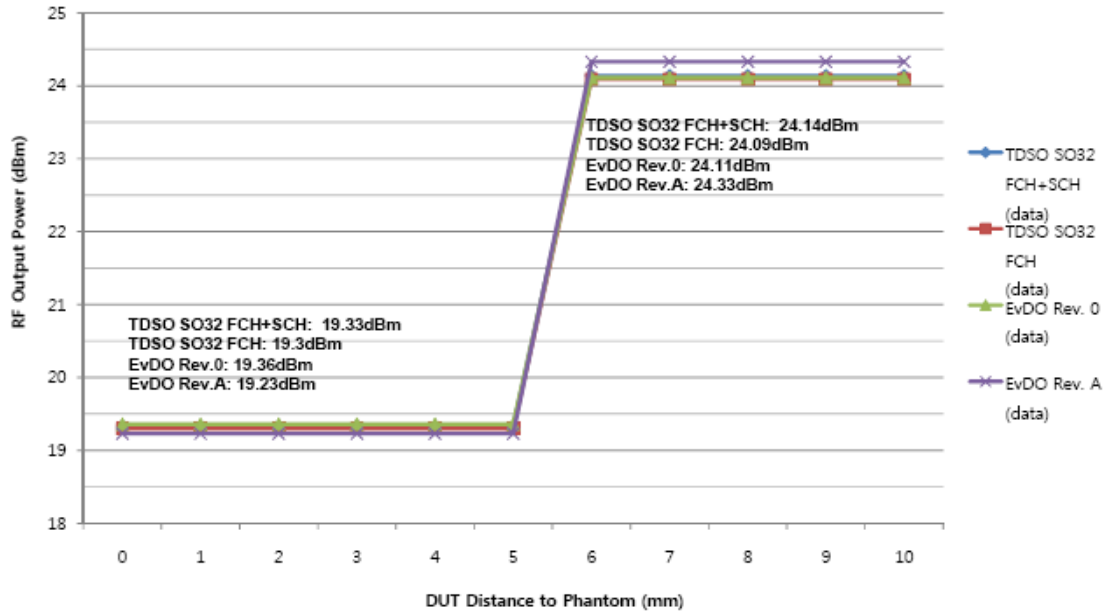

Figure 11-6  
CDMA Back off Power Reduction Graph – Back at 45° Angle

## Backoff Sensor Power Reduction (45° tilted/PCS)

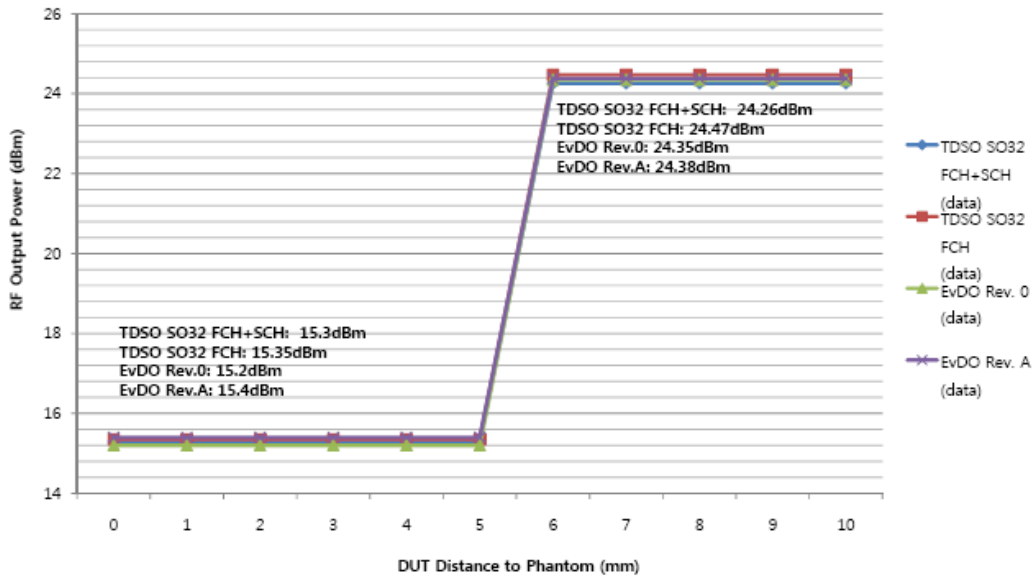

Figure 11-7  
PCS Back off Power Reduction Graph – Back at 45° Angle

FCC ID: A3LSCHI905	 PCTEST ENGINEERING LABORATORY, INC.	SAR COMPLIANCE REPORT		Reviewed by: Quality Manager
Filename: 0Y1104190774-R1.A3L	Test Dates: 05/02/11 - 05/04/11	EUT Type: Cellular/PCS CDMA/EVDO and LTE Tablet with Bluetooth and WLAN		Page 22 of 50

## 11.4 Method of SAR Measurement with Power Reduction

Based on the power-reduction activation vs. distance results for the sensors, the device was tested at 0mm distance from the phantom with the sensor activated, and additionally at a conservative 5mm (for LTE) and 10 mm (for CDMA) distance with the sensor de-activated (max power, no power reduction) from the back side; and 5 mm (for CDMA) from the top edge.

To test SAR with power back-off sensor active while touching, the device was configured in maximum power transmit mode with a base station simulator. The device was then positioned to touching position under the tissue equivalent liquid-filled flat phantom, to activate the proximity sensors.

For the additional SAR measurements with the sensors de-activated when the device is positioned away from the user, SAR is needed to be evaluated without power back-off at 10 mm (from the back) and 5mm (from the top edge) for CDMA and 5 mm (from the back) for LTE. Since the device sensor detection mechanism is active at these distances, the sensor had to be disabled via manufacturer test software for SAR test purposes. The device was then placed in maximum power transmit mode with a base station simulator under the tissue equivalent liquid-filled flat phantom at a distance of 10 mm for the back and 5 mm for the top edge with the sensor deactivated (via manufacturer test software) and then tested at maximum power.

<b>FCC ID:</b> A3LSCHI905	 <b>PCTEST</b> ENGINEERING LABORATORY, INC.	<b>SAR COMPLIANCE REPORT</b>		<b>Reviewed by:</b> Quality Manager
<b>Filename:</b> 0Y1104190774-R1.A3L	<b>Test Dates:</b> 05/02/11 - 05/04/11	<b>EUT Type:</b> Cellular/PCS CDMA/EVDO and LTE Tablet with Bluetooth and WLAN		Page 23 of 50

## 12 FCC 3G MEASUREMENT PROCEDURES

Power measurements were performed using a base station simulator under digital average power.

### 12.1 Procedures Used to Establish RF Signal for SAR

The device was placed into a simulated call using a base station simulator in a shielded chamber. Such test signals offer a consistent means for testing SAR and are recommended for evaluating SAR [4]. SAR measurements were taken with a fully charged battery. In order to verify that the device was tested and maintained at full power, it was configured with the base station simulator. The SAR measurement software calculates a reference point at the start and end of the test to check for power drifts. If SAR deviations of more than 5% occurred, the tests were repeated.

### 12.2 SAR Measurement Conditions for CDMA2000

The following procedures were performed according to FCC KDB Publication 941225 "SAR Measurement Procedures for 3G Devices" v02, October 2007.

#### 12.2.1 Output Power Verification

See 3GPP2 C.S0011/TIA-98-E as recommended by "SAR Measurement Procedures for 3G Devices" v02, October 2007. Maximum output power is verified on the High, Middle and Low channels according to procedures in section 4.4.5.2 of 3GPP2 C.S0011/TIA-98-E. SO55 tests were measured with power control bits in the "All Up" condition.

1. If the mobile station (MS) supports Reverse TCH RC 1 and Forward TCH RC 1, set up a call using Fundamental Channel Test Mode 1 (RC=1/1) with 9600 bps data rate only.
2. Under RC1, C.S0011 Table 4.4.5.2-1, Table 12-1 parameters were applied.
3. If the MS supports the RC 3 Reverse FCH, RC3 Reverse SCH<sub>0</sub> and demodulation of RC 3,4, or 5, set up a call using Supplemental Channel Test Mode 3 (RC 3/3) with 9600 bps Fundamental Channel and 9600 bps SCH<sub>0</sub> data rate.
4. Under RC3, C.S0011 Table 4.4.5.2-2, Table 13-2 was applied.
5. FCHs were configured at full rate for maximum SAR with "All Up" power control bits.

**Table 12-1**  
Parameters for Max. Power for RC1

Parameter	Units	Value
$I_{or}$	dBm/1.23 MHz	-104
$\frac{Pilot E_c}{I_{or}}$	dB	-7
$\frac{Traffic E_c}{I_{or}}$	dB	-7.4

**Table 12-2**  
Parameters for Max. Power for RC3

Parameter	Units	Value
$I_{or}$	dBm/1.23 MHz	-86
$\frac{Pilot E_c}{I_{or}}$	dB	-7
$\frac{Traffic E_c}{I_{or}}$	dB	-7.4

#### 12.2.2 Body SAR Measurements

SAR for body exposure configurations is measured in RC3 with the DUT configured to transmit at full rate on FCH with all other code channels disabled using TDSO / SO32. SAR for multiple code channels (FCH + SCH<sub>n</sub>) is not required when the maximum average output of each RF channel is less than ¼ dB higher than that measured with FCH only. Otherwise, SAR is measured on the maximum output channel (FCH + SCH<sub>n</sub>) with FCH at full rate and SCH<sub>0</sub> enabled at 9600 bps using the exposure configuration that results in the highest SAR for that channel with FCH only. When multiple code channels are enabled, the DUT output may shift by more than 0.5 dB and lead to higher SAR drifts and SCH dropouts. Body SAR was measured using TDSO / SO32 with power control bits in the "All Up"

FCC ID: A3LSCHI905	 PCTEST ENGINEERING LABORATORY, INC.	SAR COMPLIANCE REPORT		Reviewed by: Quality Manager
Filename: OY1104190774-R1.A3L	Test Dates: 05/02/11 - 05/04/11	EUT Type: Cellular/PCS CDMA/EVDO and LTE Tablet with Bluetooth and WLAN	Page 24 of 50	

Body SAR in RC1 is not required when the maximum average output of each channel is less than ¼ dB higher than that measured in RC3. Otherwise, SAR is measured on the maximum output channel in RC1; with Loopback Service Option SO55, at full rate, using the body exposure configuration that results in the highest SAR for that channel in RC3.

### 12.2.3 Body SAR Measurements with EVDO Data Devices

Body SAR is measured using Subtype 0/1 Physical Layer configurations for Rev. 0. SAR for Subtype 2 Physical layer configurations is not required for Rev. A when the maximum average output of each RF channels is less than that measured in Subtype 0/1 Physical layer configurations. Otherwise, SAR is measured on the maximum output channel for Rev. A using the exposure configuration that results in the highest SAR for the RF channels in Rev. 0.

The AT is tested with a Reverse Data Channel rate of 153.6 kbps in Subtype 0/1 Physical Layer configurations; and a Reverse Data Channel payload size of 4096 bits and Termination Target of 16 slots in Subtype 2 Physical Layer configurations. Both FTAP and FETAP are configured with a Forward Traffic Channel data rate corresponding to the 2-slot version of 307.2 kbps with the ACK Channel transmitting in all slots. AT power control should be in “All Bits Up” conditions for TAP/ETAPK Channel transmitting in all slots would be configured in the downlink for both Rev. 0 and Rev. A.

## 12.3 RF Conducted Powers

### 12.3.1 CDMA Conducted Powers

Max Power					
Band	Channel	TDSO SO32 [dBm]	TDSO SO32 [dBm]	1x EvDO Rev. 0 [dBm]	1x EvDO Rev. A [dBm]
	F-RC	FCH+SCH	FCH	(RTAP)	(RETAP)
Cellular	1013	23.86	23.85	24.04	24.22
	384	23.99	23.95	24.06	24.30
	777	24.14	24.09	24.11	24.33
PCS	25	24.26	24.21	24.00	24.03
	600	23.90	24.02	24.06	24.26
	1175	24.21	24.47	24.35	24.38

FCC ID: A3LSCHI905	 PCTEST ENGINEERING LABORATORY, INC.	SAR COMPLIANCE REPORT		Reviewed by: Quality Manager
Filename: OY1104190774-R1.A3L	Test Dates: 05/02/11 - 05/04/11	EUT Type: Cellular/PCS CDMA/EVDO and LTE Tablet with Bluetooth and WLAN		Page 25 of 50

Reduced Power					
Band	Channel	TDSO SO32 [dBm]	TDSO SO32 [dBm]	1x EvDO Rev. 0 [dBm]	1x EvDO Rev. A [dBm]
	F-RC	FCH+SCH	FCH	(RTAP)	(RETAP)
Cellular	1013	19.19	19.20	19.14	19.04
	384	19.33	19.27	19.36	19.17
	777	19.32	19.30	19.35	19.23
PCS	25	15.18	15.10	15.20	15.16
	600	15.30	15.35	15.20	15.40
	1175	15.16	15.19	15.18	15.17

Note: RC1 is only applicable for IS-95 compatibility.



**Figure 12-1**  
**Power Measurement Setup**

Note:

1. CDMA2000 Body SAR was tested under EVDO Rev 0 per FCC 3G Guidance. EVDO Rev. A was not required since the powers were not more than 0.25 dB than that of the EVDO Rev. 0 powers according to the FCC 3G Guidance.

## 12.4 Target Power with Proximity Sensor (with tolerance)

Mode	Target Conducted Power (dBm)	Target Conducted Power w/ Sensor Active (dBm)
Cellular CDMA	24.5	19.5
PCS CDMA	24.5	15.5

Note: There is no proximity sensor power reduction for WLAN modes.

FCC ID: A3LSCHI905	PCTEST ENGINEERING LABORATORY, INC.	SAR COMPLIANCE REPORT		Reviewed by: Quality Manager
Filename: 0Y1104190774-R1.A3L	Test Dates: 05/02/11 - 05/04/11	EUT Type: Cellular/PCS CDMA/EVDO and LTE Tablet with Bluetooth and WLAN		Page 26 of 50

# 13 SAR TESTING WITH IEEE 802.11 TRANSMITTERS

Normal network operating configurations are not suitable for measuring the SAR of 802.11 a/b/g transmitters. Unpredictable fluctuations in network traffic and antenna diversity conditions can introduce undesirable variations in SAR results. The SAR for these devices should be measured using chipset based test mode software to ensure the results are consistent and reliable.

## 13.1 General Device Setup

Chipset based test mode software is hardware dependent and generally varies among manufacturers. The device operating parameters established in test mode for SAR measurements must be identical to those programmed in production units, including output power levels, amplifier gain settings and other RF performance tuning parameters. The test frequencies should correspond to actual channel frequencies defined for domestic use. SAR for devices with switched diversity should be measured with only one antenna transmitting at a time during each SAR measurement, according to a fixed modulation and data rate. The same data pattern should be used for all measurements.

## 13.2 Frequency Channel Configurations [27]

802.11 a/b/g and 4.9 GHz operating modes are tested independently according to the service requirements in each frequency band. 802.11 b/g modes are tested on channels 1, 6 and 11. 802.11a is tested for UNII operations on channels 36 and 48 in the 5.15-5.25 GHz band; channels 52 and 64 in the 5.25-5.35 GHz band; channels 104, 116, 124 and 136 in the 5.470-5.725 GHz band; and channels 149 and 161 in the 5.8 GHz band. When 5.8 GHz §15.247 is also available, channels 149, 157 and 165 should be tested instead of the UNII channels. 4.9 GHz is tested on channels 1, 10 and 5 or 6, whichever has the higher output power, for 5 MHz channels; channels 11, 15 and 19 for 10 MHz channels; and channels 21 and 25 for 20 MHz channels. These are referred to as the “default test channels”. 802.11g mode was evaluated only if the output power was 0.25 dB higher than the 802.11b mode.

**Table 13-1  
802.11 Test Channels per FCC Requirements**

Mode	GHz	Channel	Turbo Channel	“Default Test Channels”		UNII
				§15.247	UNII	
802.11 b/g	2.412	1		√	∇	
	2.437	6	6	√	∇	
	2.462	11		√	∇	
802.11a	5.18	36				√
	5.20	40	42 (5.21 GHz)			*
	5.22	44				
	5.24	48	50 (5.25 GHz)			√
	5.26	52				√
	5.28	56	58 (5.29 GHz)			*
	5.30	60				*
	5.32	64				√
	5.500	100	Unknown			*
	5.520	104				√
	5.540	108				*
	5.560	112				*
	5.580	116				√
	5.600	120				*
	5.620	124				√
	5.640	128				*
	5.660	132				*
	5.680	136				√
	5.700	140			*	
	UNII or §15.247	5.745	149		√	√
5.765		153	152 (5.76 GHz)		*	*
5.785		157		√		*
5.805		161	160 (5.80 GHz)		*	√
§15.247		5.825	165		√	

FCC ID: A3LSCHI905	 PCTEST ENGINEERING LABORATORY, INC.	SAR COMPLIANCE REPORT		Reviewed by: Quality Manager
Filename: OY1104190774-R1.A3L	Test Dates: 05/02/11 - 05/04/11	EUT Type: Cellular/PCS CDMA/EVDO and LTE Tablet with Bluetooth and WLAN		Page 27 of 50

**Table 13-2**  
**IEEE 802.11b Average RF Power**

Mode	Freq [MHz]	Channel	Conducted Power [dBm]			
			Data Rate [Mbps]			
			1	2	5.5	11
802.11b	2412	1	13.01	12.92	13.05	13.02
802.11b	2437	6	13.24	13.17	13.41	13.35
802.11b	2462	11	13.30	13.33	13.41	13.45

**Table 13-3**  
**IEEE 802.11g Average RF Power**

Mode	Freq [MHz]	Channel	Conducted Power [dBm]							
			Data Rate [Mbps]							
			6	9	12	18	24	36	48	54
802.11g	2412	1	11.61	11.65	11.68	11.66	11.62	11.57	11.64	11.65
802.11g	2437	6	11.86	11.88	11.91	11.97	11.93	11.74	11.86	11.79
802.11g	2462	11	11.92	11.95	11.91	11.97	11.96	11.89	11.86	11.87

**Table 13-4**  
**IEEE 802.11n Average RF Power**

Mode	Freq [MHz]	Channel	Conducted Power [dBm]							
			Data Rate [Mbps]							
			6.5/7.2	13/14.4	19.5/21.7	26/28.9	39/43.3	52/57.8	58.5/65	65/72.2
802.11n	2412	1	11.21	11.18	11.19	11.07	11.14	11.17	11.26	11.21
802.11n	2437	6	11.76	11.67	11.82	11.85	11.73	11.78	11.84	11.81
802.11n	2462	11	12.24	12.07	12.31	12.04	12.36	12.21	12.29	12.16

**Table 13-5**  
**IEEE 802.11a Average RF Power**

Mode	Freq [MHz]	Channel	Conducted Power [dBm]							
			Data Rate [Mbps]							
			6	9	12	18	24	36	48	54
802.11a	5180	36	12.57	12.64	12.69	12.60	12.65	12.60	12.74	12.77
802.11a	5200	40	12.55	12.64	12.63	12.73	12.74	12.65	12.71	12.73
802.11a	5220	44	12.42	12.59	12.61	12.63	12.71	12.61	12.72	12.63
802.11a	5240	48	12.45	12.59	12.55	12.62	12.68	12.61	12.67	12.63
802.11a	5260	52	13.00	12.99	12.96	13.08	13.10	13.04	13.13	13.14
802.11a	5280	56	13.01	13.00	12.98	13.02	13.07	13.07	13.07	13.05
802.11a	5300	60	12.95	12.89	13.06	13.14	13.11	13.07	13.19	13.19
802.11a	5320	64	13.00	12.99	12.98	13.10	13.12	13.03	13.11	13.16
802.11a	5500	100	12.64	12.74	12.68	12.57	12.64	12.73	12.74	12.75
802.11a	5520	104	12.73	12.61	12.79	12.81	12.76	12.78	12.73	12.78
802.11a	5540	108	12.65	12.73	12.78	12.54	12.78	12.63	12.84	12.80
802.11a	5560	112	12.61	12.53	12.51	12.51	12.53	12.58	12.58	12.61
802.11a	5580	116	12.59	12.45	12.37	12.42	12.29	12.33	12.35	12.54
802.11a	5600	120	12.48	12.43	12.44	12.48	12.37	12.63	12.59	12.67
802.11a	5620	124	12.49	12.48	12.49	12.56	12.52	12.49	12.61	12.56
802.11a	5640	128	12.56	12.56	12.58	12.67	12.57	12.61	12.72	12.73
802.11a	5660	132	12.64	12.66	12.62	12.69	12.73	12.74	12.73	12.72
802.11a	5680	136	12.76	12.73	12.75	12.83	12.69	12.74	12.79	12.76
802.11a	5700	140	12.83	12.89	12.83	12.87	12.86	12.88	12.84	12.92
802.11a	5745	149	12.96	13.05	13.06	13.22	13.17	13.21	13.25	13.31
802.11a	5765	153	13.19	13.21	13.07	13.16	13.21	13.30	13.34	13.37
802.11a	5785	157	13.21	13.26	13.24	13.34	13.39	13.28	13.36	13.43
802.11a	5805	161	13.27	13.32	13.39	13.37	13.35	13.37	13.41	13.37
802.11a	5825	165	13.32	13.20	13.26	13.35	13.40	13.35	13.35	13.48

FCC ID: A3LSCHI905	 <b>PCTEST</b> ENGINEERING LABORATORY, INC.	<b>SAR COMPLIANCE REPORT</b>		Reviewed by: Quality Manager
Filename: OY1104190774-R1.A3L	Test Dates: 05/02/11 - 05/04/11	EUT Type: Cellular/PCS CDMA/EVDO and LTE Tablet with Bluetooth and WLAN		Page 28 of 50

**Table 13-6  
IEEE 802.11n Average RF Power**

Mode	Freq [MHz]	Channel	Conducted Power [dBm]							
			Data Rate [Mbps]							
			6.5/7.2	13/14.4	19.5/21.7	26/28.9	39/43.3	52/57.8	58.5/65	65/72.2
802.11n	5180	36	11.30	11.46	11.58	11.61	11.69	11.71	11.66	11.76
802.11n	<b>5200</b>	40	11.31	11.35	11.52	11.59	11.57	11.61	11.59	11.59
802.11n	5220	44	11.40	11.37	11.53	11.68	11.54	11.65	11.68	11.62
802.11n	<b>5240</b>	48	11.32	11.24	11.45	11.51	11.57	11.61	11.62	11.54
802.11n	5260	52	11.92	11.93	12.04	12.10	12.07	12.12	12.13	12.16
802.11n	<b>5280</b>	56	11.81	11.90	11.98	12.09	11.95	12.02	12.09	12.14
802.11n	5300	60	11.78	11.74	11.97	12.08	12.04	12.08	12.11	12.16
802.11n	<b>5320</b>	64	11.77	11.86	11.90	11.98	12.07	12.09	12.24	12.08
802.11n	<b>5500</b>	100	11.43	11.53	11.44	11.62	11.72	11.56	11.58	11.69
802.11n	5520	104	11.45	11.53	11.56	11.69	11.72	11.63	11.56	11.68
802.11n	<b>5540</b>	108	11.44	11.46	11.52	11.55	11.62	11.66	11.62	11.70
802.11n	5560	112	11.48	11.54	11.64	11.60	11.56	11.76	11.62	11.77
802.11n	<b>5580</b>	116	11.48	11.57	11.66	11.66	11.64	11.68	11.59	11.62
802.11n	5600	120	11.43	11.36	11.45	11.43	11.54	11.51	11.53	11.58
802.11n	<b>5620</b>	124	11.47	11.44	11.56	11.61	11.70	11.63	11.62	11.65
802.11n	5640	128	11.63	11.69	11.64	11.72	11.70	11.68	11.69	11.77
802.11n	<b>5660</b>	132	11.68	11.67	11.72	11.75	11.72	11.73	11.83	11.86
802.11n	5680	136	11.81	11.82	11.85	11.83	11.87	11.86	11.87	11.97
802.11n	<b>5700</b>	140	11.84	11.91	11.92	11.93	11.96	11.98	11.98	12.08
802.11n	5745	149	12.98	12.95	13.05	13.09	13.17	13.12	13.25	13.29
802.11n	<b>5765</b>	153	13.01	12.96	13.14	13.18	13.27	13.21	13.29	13.34
802.11n	5785	157	13.01	13.11	13.16	13.24	13.28	13.35	13.41	13.36
802.11n	<b>5805</b>	161	13.16	13.15	13.24	13.28	13.28	13.22	13.34	13.39
802.11n	5825	165	13.23	13.21	13.32	13.30	13.19	13.28	13.29	13.42



**Figure 13-1  
Power Measurement Setup**

**Notes:**

1. The maximum RF output power for all channels across all data rates was measured.
2. Per KDB 248227 Publication, for 5 GHz bands with 1g SAR < 0.8 W/kg, the highest default channel per 5 GHz band across the lowest data rates were evaluated for SAR.
3. Justification for reduced test configurations for WIFI channels per KDB Publication 248227 and April 2010 FCC/TCB Meeting Notes: IEEE 802.11n for 5GHz bands and IEEE 802.11g/n for 2.4 GHz Bands and higher data rates for both bands were not investigated since the average output powers were not greater than 0.25 dB that of the corresponding channel in the lowest data rate. Bolded powers above were tested for SAR.
4. WIFI has no power back-off capability in this device.

FCC ID: A3LSCHI905		<b>SAR COMPLIANCE REPORT</b>		Reviewed by: Quality Manager
Filename: OY1104190774-R1.A3L	Test Dates: 05/02/11 - 05/04/11	EUT Type: Cellular/PCS CDMA/EVDO and LTE Tablet with Bluetooth and WLAN		Page 29 of 50

# 14 4G LTE TEST CONFIGURATIONS

## 14.1 Frequency of Operation per 27.5

Per FCC Rule 27.5(b)(3): “(3) Two paired channels of 11 megahertz each are available for assignment in Block C in the 746-757 MHz and 776-787 MHz bands.”

## 14.2 Test Conditions

SAR tests for LTE were performed with a base station simulator, Rohde & Schwarz CMW500. Closed loop power control was used so the UE transmits with maximum output power during SAR testing.

## 14.3 LTE Measured Maximum RF Output Conducted Powers

All powers were measured with the CMW500. This device supports 10 MHz bandwidth. For 10 MHz, there is one channel (782 MHz).

There is a permanently applied MPR implemented by the module when implemented in the device. With the MPR permanently implemented, this device will never operate at higher power levels than that indicated in the Tune up procedure. MPR is enabled for this device, according to 3GPP TS36.101 Section 6.2.3 – 6.2.5 under Table 6.2.3-1. See LTE SAR Data tables in Section 16 for specific MPR per mode and configuration.

A-MPR has been disabled for all SAR Tests. LTE modes were selected according to LTE procedures in FCC KDB 941225 D05 publication. Please see notes following SAR data for required test configurations.



**Figure 14-1**  
**Power Measurement Setup**

<b>FCC ID:</b> A3LSCHI905	 <b>PCTEST</b> ENGINEERING LABORATORY, INC.	<b>SAR COMPLIANCE REPORT</b>		<b>Reviewed by:</b> Quality Manager
<b>Filename:</b> 0Y1104190774-R1.A3L	<b>Test Dates:</b> 05/02/11 - 05/04/11	<b>EUT Type:</b> Cellular/PCS CDMA/EVDO and LTE Tablet with Bluetooth and WLAN		Page 30 of 50

## 14.4 LTE Conducted Powers

### 14.4.1 Max Power

Frequency	BW	Modulation	RB Size	RB Offset	Maximum Average Power [dBm]	Target MPR	3GPP Max MPR allowed
782 MHz	10 MHz	QPSK	1	0	22.80	0.0	0
		16QAM	1	0	22.17	0.8	0 ~ 1
		QPSK	1	49	23.00	0.0	0
		16QAM	1	49	22.40	0.8	0 ~ 1
		QPSK	25	12	22.20	1.0	0 ~ 1
		16QAM	25	12	20.90	1.9	0 ~ 2
		QPSK	50	0	21.90	1.0	0 ~ 1
		16QAM	50	0	21.35	1.9	0 ~ 2

### 14.4.2 Reduced Power

Frequency	BW	Modulation	RB Size	RB Offset	Maximum Average Power [dBm]	Target MPR	3GPP Max MPR allowed
782 MHz	10 MHz	QPSK	1	0	19.04	0.0	0
		16QAM	1	0	19.37	0.0	0 ~ 1
		QPSK	1	49	19.44	0.0	0
		16QAM	1	49	19.60	0.0	0 ~ 1
		QPSK	25	12	19.26	0.0	0 ~ 1
		16QAM	25	12	19.26	0.0	0 ~ 2
		QPSK	50	0	19.40	0.0	0 ~ 1
		16QAM	50	0	19.43	0.0	0 ~ 2

Proximity sensor power reduction for LTE is applied from the maximum conducted power before LTE MPR is implemented for each configuration. There is no LTE MPR when the proximity sensor power reduction is applied.

Notes: LTE SAR Test Considerations

- Per KDB Publication 941225 D05 Page 4, 3) A), QPSK with 50% RB is required.
- Per KDB Publication 941225 D05 Page 4, 3) B), QPSK with 1 RB for both channel edges are required.
- Per KDB Publication 941225 D05 Page 4, 4) A), 16QAM with 50% RB is required.
- Per KDB Publication 941225 D05 Page 4, 4) B), 16QAM with 1RB for both channel edges are required.
- Per KDB Publication 941225 D05 Page 4, A) I), 100% RB Allocation is not required to be tested since SAR is not > 1.45 W/kg.

## 14.5 Target Power with Proximity Sensor (with tolerance)

Mode	Target Conducted Power (dBm)	Target Conducted Power w/ Sensor Active (dBm)
LTE	23	19.5

Note: There is no proximity sensor power reduction for WLAN modes.

FCC ID: A3LSCHI905	 PCTEST ENGINEERING LABORATORY, INC.	SAR COMPLIANCE REPORT		Reviewed by: Quality Manager
Filename: OY1104190774-R1.A3L	Test Dates: 05/02/11 - 05/04/11	EUT Type: Cellular/PCS CDMA/EVDO and LTE Tablet with Bluetooth and WLAN	Page 31 of 50	

# 15 SYSTEM VERIFICATION

## 15.1 Tissue Verification



**Table 15-1  
Measured Tissue Properties**

Calibrated for Tests Performed on:	Tissue Type	Measured Frequency (MHz)	Measured Conductivity, $\sigma$ (S/m)	Measured Dielectric Constant, $\epsilon$	TARGET Conductivity, $\sigma$ (S/m)	TARGET Dielectric Constant, $\epsilon$	% dev $\sigma$	% dev $\epsilon$
05/03/2011	750B	725	0.964	56.70	0.96	55.82	0.42%	1.58%
		740	0.965	56.62	0.96	55.73	0.42%	1.59%
		755	0.973	56.40	0.96	55.65	1.04%	1.35%
		770	0.994	56.24	0.96	55.56	3.11%	1.22%
		785	1.004	55.92	0.97	55.48	4.04%	0.79%
		800	1.012	55.91	0.97	55.40	4.65%	0.93%
05/04/2011	835B	820	0.947	53.20	0.97	55.28	-2.27%	-3.77%
		835	0.957	53.13	0.97	55.20	-1.34%	-3.75%
		850	0.969	53.21	0.99	55.15	-1.92%	-3.52%
04/27/2011	1900B	1850	1.477	52.57	1.52	53.30	-2.83%	-1.37%
		1880	1.504	52.43	1.52	53.30	-1.05%	-1.63%
		1910	1.532	52.29	1.52	53.30	0.79%	-1.89%
05/03/2011	2450B	2401	1.949	50.46	1.90	52.77	2.42%	-4.37%
		2450	2.008	50.18	1.95	52.70	2.97%	-4.78%
		2499	2.078	50.05	2.02	52.64	2.92%	-4.92%
05/03/2011	5200B-5800B	5170	5.244	49.21	5.26	49.06	-0.38%	0.32%
		5210	5.324	48.90	5.31	49.00	0.24%	-0.21%
		5250	5.400	49.06	5.36	48.95	0.78%	0.23%
		5270	5.371	48.95	5.38	48.92	-0.19%	0.06%
		5310	5.512	48.81	5.43	48.87	1.55%	-0.11%
		5350	5.542	48.65	5.47	48.81	1.32%	-0.33%
		5470	5.684	48.28	5.62	48.65	1.23%	-0.76%
		5510	5.769	48.49	5.66	48.59	1.91%	-0.21%
		5550	5.804	48.15	5.71	48.54	1.68%	-0.80%
		5570	5.855	48.15	5.73	48.51	2.16%	-0.75%
		5610	5.845	48.18	5.78	48.46	1.16%	-0.57%
		5650	6.025	47.90	5.83	48.40	3.43%	-1.04%
		5670	6.003	48.09	5.85	48.38	2.65%	-0.59%
		5710	6.055	47.91	5.90	48.32	2.71%	-0.85%
		5750	6.167	47.70	5.94	48.27	3.79%	-1.18%
		5770	6.216	47.74	5.97	48.24	4.21%	-1.04%
		5810	6.154	47.64	6.01	48.19	2.36%	-1.13%
5850	6.304	47.56	6.06	48.13	4.06%	-1.19%		

Note: KDB Publication 450824 was ensured to be applied for probe calibration frequencies greater than or equal to 50 MHz of the DUT frequencies.

The above measured tissue parameters were used in the DASY software to perform interpolation via the DASY software to determine actual dielectric parameters at the test frequencies (per IEEE 1528 6.6.1.2). The SAR test plots may slightly differ from the table above since the DASY software rounds to three significant digits.

Probe calibration used within  $\pm 100$  MHz of the test frequency in either 5.725 - 5.85 or 5.47-5.725 GHz is acceptable per KDB Publication 865664 since the design of the SAR probe supports the extended frequency, provided the DASY software version recommended is used for the tests, and the expanded calibration uncertainty ( $k=2$ ) is less than or equal to 15% (See SAR probe calibration certificate for this information). The dielectric and conductivities measured are within 10% and 5% respectively of the target parameters specified in Supplement C 01-01.

FCC ID: A3LSCHI905	 PCTEST ENGINEERING LABORATORY, INC.	SAR COMPLIANCE REPORT		Reviewed by: Quality Manager
Filename: OY1104190774-R1.A3L	Test Dates: 05/02/11 - 05/04/11	EUT Type: Cellular/PCS CDMA/EVDO and LTE Tablet with Bluetooth and WLAN		Page 32 of 50

## 15.2 Measurement Procedure for Tissue verification

- 1) The network analyzer and probe system was configured and calibrated.
- 2) The probe was immersed in the sample which was placed in a nonmetallic container. Trapped air bubbles beneath the flange were minimized by placing the probe at a slight angle.
- 3) The complex admittance with respect to the probe aperture was measured
- 4) The complex relative permittivity , for example from the below equation (Pournaropoulos and Misra):

$$Y = \frac{j2\omega\epsilon_r\epsilon_0}{[\ln(b/a)]^2} \int_a^b \int_a^b \int_0^\pi \cos\phi' \frac{\exp[-j\omega r(\mu_0\epsilon_r\epsilon_0)^{1/2}]}{r} d\phi' d\rho' d\rho$$

where Y is the admittance of the probe in contact with the sample, the primed and unprimed coordinates refer to source and observation points, respectively,  $r^2 = \rho^2 + \rho'^2 - 2\rho\rho' \cos\phi'$  ,  $\omega$  is the angular frequency, and  $j = \sqrt{-1}$  .

## 15.3 Test System Verification

Prior to assessment, the system is verified to  $\pm 10\%$  of the manufacturer SAR measurement on the reference dipole at the time of calibration.

**Table 15-2**  
**System Verification Results**

System Verification TARGET & MEASURED										
Date:	Amb. Temp (°C)	Liquid Temp (°C)	Input Power (W)	Tissue Frequency (MHz)	Dipole SN	Tissue Type	Measured SAR <sub>1g</sub> (W/kg)	1 W Target SAR <sub>1g</sub> (W/kg)	1 W Normalized SAR <sub>1g</sub> (W/kg)	Deviation (%)
05/03/2011	23.4	21.8	0.250	750	1003	Body	2.16	8.850	8.640	-2.37%
05/04/2011	24.2	22.4	0.063	835	4d047	Body	0.617	9.850	9.794	-0.57%
05/02/2011	24.0	22.8	0.040	1900	502	Body	1.66	41.100	41.500	0.97%
05/03/2011	24.3	22.9	0.025	2450	797	Body	1.38	52.300	55.200	5.54%
05/03/2011	23.6	22.3	0.025	5200	1057	Body	1.92	77.700	76.800	-1.16%
05/03/2011	23.8	22.5	0.025	5500	1057	Body	2.04	84.400	81.600	-3.32%
05/03/2011	24.0	22.7	0.025	5800	1057	Body	1.84	75.000	73.600	-1.87%

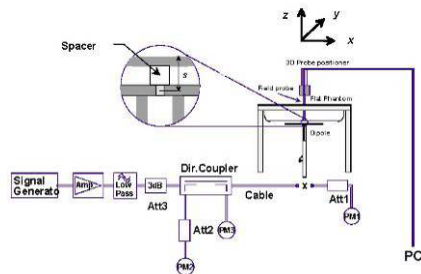

**Figure 15-1**  
**System Verification Setup Diagram**



**Figure 15-2**  
**System Verification Setup Photo**



FCC ID: A3LSCHI905	PCTEST ENGINEERING LABORATORY, INC.	SAR COMPLIANCE REPORT	SAMSUNG	Reviewed by: Quality Manager
Filename: OY1104190774-R1.A3L	Test Dates: 05/02/11 - 05/04/11	EUT Type: Cellular/PCS CDMA/EVDO and LTE Tablet with Bluetooth and WLAN	Page 33 of 50	

**Table 16-1  
CDMA Body SAR Results**

MEASUREMENT RESULTS										
FREQUENCY		Mode	Service	Conducted Power [dBm]	Conducted Power Target Level [dBm]	Power Drift [dB]	Spacing	Serial Number	Side	SAR (1g)
MHz	Ch.									(W/kg)
836.52	384	Cell. CDMA	EVDO	19.36	19.50	0.09	0.0 cm	FCC #2	back*	0.669
836.52	384	Cell. CDMA	EVDO	19.36	19.50	0.00	0.0 cm	FCC #2	top*	0.250
836.52	384	Cell. CDMA	EVDO	24.06	24.50	0.04	0.0 cm	FCC #1	left	0.454
836.52	384	Cell. CDMA	EVDO	24.06	24.50	0.06	0.5 cm	FCC #1	top	0.369
836.52	384	Cell. CDMA	EVDO	24.06	24.50	0.05	1.0 cm	FCC #1	back	0.570
1880.00	600	PCS CDMA	EVDO	15.20	15.50	0.05	0.0 cm	FCC #2	back*	0.759
1880.00	600	PCS CDMA	EVDO	15.20	15.50	0.07	0.0 cm	FCC #2	top*	0.229
1880.00	600	PCS CDMA	EVDO	24.06	24.50	0.00	0.0 cm	FCC #1	left	0.214
1880.00	600	PCS CDMA	EVDO	24.06	24.50	-0.01	0.5 cm	FCC #1	top	0.685
1880.00	600	PCS CDMA	EVDO	24.06	24.50	-0.03	1.0 cm	FCC #1	back	0.627
<b>ANSI / IEEE C95.1 1992 - SAFETY LIMIT</b>							<b>Body</b>			
<b>Spatial Peak</b>							<b>1.6 W/kg (mW/g)</b>			
<b>Uncontrolled Exposure/General Population</b>							<b>averaged over 1 gram</b>			



## Notes:

- The test data reported are the worst-case SAR value with the position set in a typical configuration. Test procedures used were according to FCC/OET Bulletin 65, Supplement C [June 2001].
- Per KDB 448498 4) b) i) the back side is required to be tested touching the flat phantom.
- This device is capable of multiple display orientations supporting both portrait and landscape positions. Therefore per KDB 447498 4) b) ii) (2), SAR testing applies for the tablet edges with antennas located within 5 cm of each tablet edge closest to the user (with KDB 616217 applied to edges with antennas located  $\geq 5$  cm from the user). According to KDB 447498 4) b) ii) (2), for each antenna, SAR is only required for the edge with the most conservative exposure condition.
- All modes of operation were investigated, and worst-case results are reported.
- Tissue parameters and temperatures are listed on the SAR plots.
- Batteries are fully charged for all readings.
- Liquid tissue depth was at least 15.0 cm.
- Device was tested using a fixed spacing.
- CDMA2000 Body SAR was tested under EVDO Rev 0. Per FCC 3G Guidance. EVDO Rev. A was not required since the powers were not more than 0.25 dB than that of the EVDO Rev. 0 powers according to the FCC 3G Guidance.
- Justification for reduced test configurations: Per KDB 447498 D01 1) e) i), when the SAR procedures require multiple channels to be tested and the 1-g SAR for the highest output channel is less than 0.8 W/kg, the other channels are not required.
- Asterisk (\*) denotes power reduction activated.
- Per lab KDB Inquiry 738936, a conservative additional test distance of 10 mm from the back and 5 mm from the top were tested for SAR at the maximum power. See Section 11.3 for more details.

FCC ID: A3LSCHI905	 <b>PCTEST</b> ENGINEERING LABORATORY, INC.	<b>SAR COMPLIANCE REPORT</b>		Reviewed by: Quality Manager
Filename: OY1104190774-R1.A3L	Test Dates: 05/02/11 - 05/04/11	EUT Type: Cellular/PCS CDMA/EVDO and LTE Tablet with Bluetooth and WLAN		Page 34 of 50

**Table 16-2**  
**LTE Body SAR Results**

MEASUREMENT RESULTS													
FREQUENCY		Mode	Modulation	Conducted Power [dBm]	LTE MPR [dB]	Conducted Power Target Level [dBm]	Power Drift [dB]	Spacing	Serial Number	# of RBs	RB Offset	Side	SAR (1g)
MHz	Ch.												(W/kg)
782	23230	LTE	QPSK	19.26	0	19.50	-0.03	0.0 cm	FCC #2	25	12	Back*	0.638
782	23230	LTE	QPSK	19.04	0	19.50	0.03	0.0 cm	FCC #2	1	0	Back*	0.565
782	23230	LTE	QPSK	19.44	0	19.50	0.02	0.0 cm	FCC #2	1	49	Back*	0.600
782	23230	LTE	16QAM	19.26	0	19.50	0.00	0.0 cm	FCC #2	25	12	Back*	0.637
782	23230	LTE	16QAM	19.37	0	19.50	0.02	0.0 cm	FCC #2	1	0	Back*	0.629
782	23230	LTE	16QAM	19.60	0	19.50	-0.04	0.0 cm	FCC #2	1	49	Back*	0.642
782	23230	LTE	QPSK	22.20	1	22.00	0.01	0.0 cm	FCC #1	25	12	Top	0.871
782	23230	LTE	QPSK	22.80	0	23.00	0.06	0.0 cm	FCC #1	1	0	Top	1.050
782	23230	LTE	QPSK	23.00	0	23.00	-0.06	0.0 cm	FCC #1	1	49	Top	1.010
782	23230	LTE	16QAM	20.90	1.9	21.10	0.09	0.0 cm	FCC #1	25	12	Top	0.707
782	23230	LTE	16QAM	22.17	0.8	22.20	0.08	0.0 cm	FCC #1	1	0	Top	0.863
782	23230	LTE	16QAM	22.40	0.8	22.20	-0.06	0.0 cm	FCC #1	1	49	Top	0.915
782	23230	LTE	QPSK	22.20	1	22.00	0.00	0.0 cm	FCC #1	25	12	Right	0.085
782	23230	LTE	QPSK	22.80	0	23.00	-0.07	0.0 cm	FCC #1	1	0	Right	0.097
782	23230	LTE	QPSK	23.00	0	23.00	0.08	0.0 cm	FCC #1	1	49	Right	0.075
782	23230	LTE	16QAM	20.90	1.9	21.10	0.08	0.0 cm	FCC #1	25	12	Right	0.067
782	23230	LTE	16QAM	22.17	0.8	22.20	-0.08	0.0 cm	FCC #1	1	0	Right	0.082
782	23230	LTE	16QAM	22.40	0.8	22.20	0.01	0.0 cm	FCC #1	1	49	Right	0.069
782	23230	LTE	QPSK	22.20	1	22.00	0.09	0.5 cm	FCC #1	25	12	Back	0.413
782	23230	LTE	QPSK	22.80	0	23.00	0.08	0.5 cm	FCC #1	1	0	Back	0.487
782	23230	LTE	QPSK	23.00	0	23.00	0.01	0.5 cm	FCC #1	1	49	Back	0.526
782	23230	LTE	16QAM	20.90	1.9	21.10	0.09	0.5 cm	FCC #1	25	12	Back	0.412
782	23230	LTE	16QAM	22.17	0.8	22.20	-0.06	0.5 cm	FCC #1	1	0	Back	0.472
782	23230	LTE	16QAM	22.40	0.8	22.20	-0.01	0.5 cm	FCC #1	1	49	Back	0.488
<b>ANSI / IEEE C95.1 1992 - SAFETY LIMIT</b>								<b>Body</b>					
<b>Spatial Peak</b>								<b>1.6 W/kg (mW/g)</b>					
<b>Uncontrolled Exposure/General Population</b>								<b>averaged over 1 gram</b>					

FCC ID: A3LSCHI905	 <b>PCTEST</b> <small>ENGINEERING LABORATORY, INC.</small>	<b>SAR COMPLIANCE REPORT</b>		Reviewed by: Quality Manager
Filename: OY1104190774-R1.A3L	Test Dates: 05/02/11 - 05/04/11	EUT Type: Cellular/PCS CDMA/EVDO and LTE Tablet with Bluetooth and WLAN		Page 35 of 50

Notes:

1. The test data reported are the worst-case SAR value with the position set in a typical configuration. Test procedures used were according to FCC/OET Bulletin 65, Supplement C [June 2001].
2. Per KDB 448498 4) b) i) the back side is required to be tested touching the flat phantom.
3. This device is capable of multiple display orientations supporting both portrait and landscape positions. Therefore per KDB 447498 4) b) ii) (2), SAR testing applies for the tablet edges with antennas located within 5 cm of each tablet edge closest to the user (with KDB 616217 applied to edges with antennas located  $\geq 5$  cm from the user). According to KDB 447498 4) b) ii) (2), for each antenna, SAR is only required for the edge with the most conservative exposure condition.
4. All modes of operation were investigated, and worst-case results are reported.
5. Tissue parameters and temperatures are listed on the SAR plots.
6. Batteries are fully charged for all readings.
7. Liquid tissue depth was at least 15.0 cm.
8. Device was tested using a fixed spacing.
9. LTE SAR Test Considerations:
  - a. Per KDB Publication 941225 D05 Page 4, 3) A), QPSK with 50% RB is required.
  - b. Per KDB Publication 941225 D05 Page 4, 3) B), QPSK with 1 RB for both channel edges are required.
  - c. Per KDB Publication 941225 D05 Page 4, 4) A), 16QAM with 50% RB is required.
  - d. Per KDB Publication 941225 D05 Page 4, 4) B), 16QAM with 1RB for both channel edges are required.
  - e. Per KDB Publication 941225 D05 Page 4, A) I), 100% RB Allocation is not required to be tested since SAR is not  $> 1.45$  W/kg.
10. There is a permanently applied MPR implemented by the manufacturer. MPR is enabled for this device, according to 3GPP TS36.101 Section 6.2.3 – 6.2.5 under Table 6.2.3-1.
11. Asterisk (\*) denotes power reduction activated.
12. Per lab KDB Inquiry 450108, additional SAR Testing at a conservative additional test distance of 5 mm from the back was tested for SAR at the maximum power. See Section 11.3 for more details.
13. A-MPR was disabled for all SAR tests.



FCC ID: A3LSCHI905		SAR COMPLIANCE REPORT		Reviewed by: Quality Manager
Filename: 0Y1104190774-R1.A3L	Test Dates: 05/02/11 - 05/04/11	EUT Type: Cellular/PCS CDMA/EVDO and LTE Tablet with Bluetooth and WLAN		Page 36 of 50

**Table 16-3  
2.4 GHz Body SAR Results**

MEASUREMENT RESULTS										
FREQUENCY		Mode	Service	Conducted Power [dBm]	Power Drift [dB]	Spacing	Serial Number	Data Rate (Mbps)	Side	SAR
MHz	Ch.									(W/kg)
2462	11	IEEE 802.11b	DSSS	13.30	-0.08	0.0 cm	FCC #3	1	back	0.686
2462	11	IEEE 802.11b	DSSS	13.30	0.04	0.0 cm	FCC #3	1	bottom	0.045
2412	1	IEEE 802.11b	DSSS	13.01	0.10	0.0 cm	FCC #3	1	right	1.070
2437	6	IEEE 802.11b	DSSS	13.24	0.06	0.0 cm	FCC #3	1	right	1.140
2462	11	IEEE 802.11b	DSSS	13.30	0.07	0.0 cm	FCC #3	1	right	1.180
ANSI / IEEE C95.1 1992 - SAFETY LIMIT Spatial Peak Uncontrolled Exposure/General Population						Body 1.6 W/kg (mW/g) averaged over 1 gram				

Notes:

- The test data reported are the worst-case SAR value with the position set in a typical configuration. Test procedures used were according to FCC/OET Bulletin 65, Supplement C [June 2001].
- Per KDB 448498 4) b) i) the back side is required to be tested touching the flat phantom.
- This device is capable of multiple display orientations supporting both portrait and landscape positions. Therefore per KDB 447498 4) b) ii) (2), SAR testing applies for the tablet edges with antennas located within 5 cm of each tablet edge closest to the user (with KDB 616217 applied to edges with antennas located  $\geq 5$  cm from the user). According to KDB 447498 4) b) ii) (2), for each antenna, SAR is only required for the edge with the most conservative exposure condition.
- All modes of operation were investigated, and worst-case results are reported.
- Batteries are fully charged for all readings.
- Tissue parameters and temperatures are listed on the SAR plots.
- Liquid tissue depth is was at least 15.0 cm.
- Device was tested using a fixed spacing.
- Justification for reduced test configurations for WIFI channels per KDB Publication 248227 and April 2010 FCC/TCB Meeting Notes: Highest average RF output power channel for the lowest data rate were selected for SAR evaluation. Other IEEE 802.11 modes (including 802.11g/n and higher data rates) were not investigated since the average output powers were not greater than 0.25 dB than that of the corresponding channel in the lowest data rate IEEE 802.11b mode.
- WLAN transmission was verified using a spectrum analyzer.
- There is no power reduction for WIFI.
- Per FCC KDB 447498 4) b) since the output power of the antenna is  $\leq 60/f$  (GHz), Bluetooth SAR is not required for both back side and edge exposure conditions.

FCC ID: A3LSCHI905	 PCTEST ENGINEERING LABORATORY, INC.	SAR COMPLIANCE REPORT		Reviewed by: Quality Manager
Filename: OY1104190774-R1.A3L	Test Dates: 05/02/11 - 05/04/11	EUT Type: Cellular/PCS CDMA/EVDO and LTE Tablet with Bluetooth and WLAN		Page 37 of 50

**Table 16-4  
5 GHz Body SAR Results**

<b>MEASUREMENT RESULTS</b>										
FREQUENCY		Mode	Service	Conducted Power [dBm]	Power Drift [dB]	Spacing	Serial Number	Data Rate (Mbps)	Side	SAR (1g)
MHz	Ch.									(W/kg)
5180	36	IEEE 802.11a	OFDM	12.57	0.09	0.0 cm	FCC #3	6	back	0.139
5180	36	IEEE 802.11a	OFDM	12.57	-0.06	0.0 cm	FCC #3	6	bottom	0.029
5180	36	IEEE 802.11a	OFDM	12.57	0.05	0.0 cm	FCC #3	6	right	0.259
5280	56	IEEE 802.11a	OFDM	13.01	0.05	0.0 cm	FCC #3	6	back	0.294
5280	56	IEEE 802.11a	OFDM	13.01	0.09	0.0 cm	FCC #3	6	bottom	0.048
5280	56	IEEE 802.11a	OFDM	13.01	0.08	0.0 cm	FCC #3	6	right	0.284
5700	140	IEEE 802.11a	OFDM	12.83	0.07	0.0 cm	FCC #3	6	back	0.534
5700	140	IEEE 802.11a	OFDM	12.83	0.08	0.0 cm	FCC #3	6	bottom	0.048
5700	140	IEEE 802.11a	OFDM	12.83	0.05	0.0 cm	FCC #3	6	right	0.654
5825	165	IEEE 802.11a	OFDM	13.32	-0.06	0.0 cm	FCC #3	6	back	0.464
5825	165	IEEE 802.11a	OFDM	13.32	0.05	0.0 cm	FCC #3	6	bottom	0.086
5825	165	IEEE 802.11a	OFDM	13.32	0.07	0.0 cm	FCC #3	6	right	0.715
<b>ANSI / IEEE C95.1 1992 - SAFETY LIMIT</b>						<b>Body</b>				
<b>Spatial Peak</b>						<b>1.6 W/kg (mW/g)</b>				
<b>Uncontrolled Exposure/General Population</b>						averaged over 1 gram				

Notes:

- The test data reported are the worst-case SAR value with the position set in a typical configuration. Test procedures used were according to FCC/OET Bulletin 65, Supplement C [June 2001].
- Per KDB 448498 4) b) i) the back side is required to be tested touching the flat phantom.
- This device is capable of multiple display orientations supporting both portrait and landscape positions. Therefore per KDB 447498 4) b) ii) (2), SAR testing applies for the tablet edges with antennas located within 5 cm of each tablet edge closest to the user (with KDB 616217 applied to edges with antennas located  $\geq 5$  cm from the user). According to KDB 447498 4) b) ii) (2), for each antenna, SAR is only required for the edge with the most conservative exposure condition.
- All modes of operation were investigated, and worst-case results are reported.
- Batteries are fully charged for all readings.
- Tissue parameters and temperatures are listed on the SAR plots.
- Liquid tissue depth is was at least 15.0 cm.
- Device was tested using a fixed spacing.
- Justification for reduced test configurations for WIFI channels per KDB Publication 248227 and April 2010 FCC/TCB Meeting Notes: Highest average RF output power channel for the lowest data rate were selected for SAR evaluation. Other IEEE 802.11 modes (including 802.11n and higher data) were not investigated since the average output powers were not greater than 0.25 dB than that of the corresponding channel in the lowest data rate IEEE 802.11a mode.
- Per KDB 248227 Publication, since the SAR < 0.8 W/kg, no additional channels were required.
- WLAN transmission was verified using a spectrum analyzer.
- There is no power reduction for WIFI.

<b>FCC ID:</b> A3LSCHI905		<b>SAR COMPLIANCE REPORT</b>		<b>Reviewed by:</b> Quality Manager
<b>Filename:</b> OY1104190774-R1.A3L	<b>Test Dates:</b> 05/02/11 - 05/04/11	<b>EUT Type:</b> Cellular/PCS CDMA/EVDO and LTE Tablet with Bluetooth and WLAN		Page 38 of 50

# 17 SIMULTANEOUS TRANSMISSION ANALYSIS

## 17.1 Simultaneous Transmission Information

This device contains multiple transmitters that may operate simultaneously and therefore, require a simultaneous transmission analysis according to KDB Publication 447498 4) b) iii) procedures (See Section 10.3). The tablet procedures required by KDB Publication 447498 generally do not require separate hotspot mode testing.

Bluetooth and WIFI cannot transmit simultaneously since it shares the same circuit path and are switched by the radio. LTE and CDMA cannot transmit simultaneously.

When Hotspot is enabled, all 5 GHz bands are disabled. Therefore there is no simultaneous transmission with 5 GHz. Table 17-1 shows all possible simultaneous transmission scenarios for this device.

**Table 17-1  
Simultaneous Transmission Scenarios**

Simult Tx	Configuration	Spacing	Cell. CDMA SAR (W/kg)	2.4 GHz WIFI SAR (W/kg)	Σ SAR (W/kg)	Simult Tx	Configuration	Spacing	PCS CDMA SAR (W/kg)	2.4 GHz WIFI SAR (W/kg)	Σ SAR (W/kg)
Body SAR	Back*	0 cm	0.669	0.686	1.355	Body SAR	Back*	0 cm	0.759	0.686	1.445
	Back	1.0 cm	0.570	<0.686	<1.256		Back	1.0 cm	0.627	<0.686	<1.313
	Top*	0 cm	0.250	-	0.250		Top*	0 cm	0.229	-	0.229
	Top	0.5 cm	0.369	-	0.369		Top	0.5 cm	0.685	-	0.685
	Bottom	0 cm	-	0.045	-		Bottom	0 cm	-	0.045	0.045
	Right	0 cm	-	1.180	1.180		Right	0 cm	-	1.180	1.180
	Left	0 cm	0.454	-	0.454		Left	0 cm	0.214	-	0.214
	Simult Tx	Configuration	Spacing	LTE-750 SAR (W/kg)	2.4 GHz WIFI SAR (W/kg)	Σ SAR (W/kg)					
Body SAR	Back*	0 cm	0.642	0.686	1.328						
	Back	1.0 cm	0.526	<0.686	<1.212						
	Top	0 cm	1.050	-	1.050						
	Bottom	0 cm	-	0.045	0.045						
	Right	0 cm	0.097	1.180	1.277						
	Left	0 cm	-	-	-						

**Notes:**

1. “-” SAR results shown in the tables are zero for summation purposes. SAR was not required to be measured due to exclusions mentioned in Section 11.2.
2. Asterisk (\*) denotes power reduction activated
3. For sum SAR calculations at 1.0 cm, WLAN SAR values for 0.0 cm were used since the 0.0 cm test distance for WLAN was more conservative. “<” denotes the 0.0 cm WLAN SAR values used for the summations.

## 17.2 Simultaneous Transmission Conclusion

Per KDB Publication 447498 4) b) iii), no aggregate volumetric simultaneous transmission is required for the tablet, since the sum SAR and the SAR to peak separation ratios are < 0.3 for all antenna pairs according to procedures in KDB 648474.

FCC ID: A3LSCHI905	 PCTEST ENGINEERING LABORATORY, INC.	SAR COMPLIANCE REPORT		Reviewed by: Quality Manager
Filename: 0Y1104190774-R1.A3L	Test Dates: 05/02/11 - 05/04/11	EUT Type: Cellular/PCS CDMA/EVDO and LTE Tablet with Bluetooth and WLAN		Page 39 of 50

# 18 EQUIPMENT LIST

Manufacturer	Model	Description	Cal Date	Cal Interval	Cal Due	Serial Number
Agilent	85070B	Dielectric Probe Kit	8/22/2010	Annual	8/22/2011	US33020316
Agilent	8648D	(9kHz-4GHz) Signal Generator	10/13/2010	Annual	10/13/2011	3613A00315
Agilent	8753E	(30kHz-6GHz) Network Analyzer	4/21/2011	Annual	4/21/2012	JP38020182
Agilent	E5515C	Wireless Communications Test Set	10/11/2010	Annual	10/11/2011	GB46110872
Agilent	E5515C	Wireless Communications Test Set	10/8/2010	Annual	10/8/2011	GB46310798
Agilent	E5515C	Wireless Communications Test Set	8/13/2010	Annual	8/13/2011	GB41450275
Agilent	E8257D	(250kHz-20GHz) Signal Generator	4/8/2011	Annual	4/8/2012	MY45470194
Gigatronics	80701A	(0.05-18GHz) Power Sensor	10/11/2010	Annual	10/11/2011	1833460
Gigatronics	8651A	Universal Power Meter	10/11/2010	Annual	10/11/2011	8650319
Index SAR	IXTL-010	Dielectric Measurement Kit	N/A		N/A	N/A
Index SAR	IXTL-030	30MM TEM line for 6 GHz	N/A		N/A	N/A
Pasternack	PE2208-6	Bidirectional Coupler	N/A		N/A	N/A
Pasternack	PE2209-10	Bidirectional Coupler	N/A		N/A	N/A
Rohde & Schwarz	CMU200	Base Station Simulator	11/11/2010	Annual	11/11/2011	836371/0079
Rohde & Schwarz	CMU200	Base Station Simulator	6/21/2010	Annual	6/21/2011	833855/0010
Rohde & Schwarz	NRVD	Dual Channel Power Meter	4/8/2011	Biennial	4/8/2013	101695
SPEAG	D1900V2	1900 MHz SAR Dipole	2/17/2011	Annual	2/17/2012	502
SPEAG	D1900V2	1900 MHz SAR Dipole	8/18/2009	Biennial	8/18/2011	5d080
SPEAG	D2450V2	2450 MHz SAR Dipole	8/27/2009	Biennial	8/27/2011	719
SPEAG	D2450V2	2450 MHz SAR Dipole	2/8/2011	Annual	2/8/2012	797
SPEAG	D2600V2	2600 MHz SAR Dipole	4/15/2011	Biennial	4/15/2013	1004
SPEAG	D5GHzV2	5 GHz SAR Dipole	8/19/2009	Biennial	8/19/2011	1007
SPEAG	D5GHzV2	5 GHz SAR Dipole	2/11/2011	Annual	2/11/2012	1057
SPEAG	D835V2	835 MHz SAR Dipole	2/9/2011	Annual	2/9/2012	4d047
SPEAG	D835V2	835 MHz SAR Dipole	8/24/2009	Biennial	8/24/2011	4d026
SPEAG	DAE3	Dasy Data Acquisition Electronics	11/18/2010	Annual	11/18/2011	455
SPEAG	DAE4	Dasy Data Acquisition Electronics	3/17/2011	Annual	3/17/2012	704
SPEAG	DAE4	Dasy Data Acquisition Electronics	4/20/2011	Annual	4/20/2012	665
SPEAG	DAE4	Dasy Data Acquisition Electronics	2/21/2011	Annual	2/21/2012	649
SPEAG	ES3DV2	SAR Probe	9/21/2010	Annual	9/21/2011	3022
SPEAG	EX3DV4	SAR Probe	8/19/2010	Annual	8/19/2011	3561
SPEAG	EX3DV4	SAR Probe	2/14/2011	Annual	2/14/2012	3550
SPEAG	DAE4	Dasy Data Acquisition Electronics	7/8/2010	Annual	7/8/2011	859
SPEAG	D750V3	750 MHz Dipole	2/14/2011	Annual	2/14/2012	1003
SPEAG	ES3DV3	SAR Probe	3/24/2011	Annual	3/24/2012	3213
SPEAG	ES3DV3	SAR Probe	4/18/2011	Annual	4/18/2012	3209
Rohde & Schwarz	SMIQ03B	Signal Generator	4/6/2011	Annual	4/6/2012	DE27259
SPEAG	D1640V2	1640 MHz Dipole	8/17/2010	Biennial	8/17/2012	321
Rohde & Schwarz	CMW500	LTE Radio Communication Tester	8/30/2010	Annual	8/30/2011	100976
Anritsu	MA2481A	Power Sensor	2/7/2011	Annual	2/7/2012	5318
Anritsu	MA2481A	Power Sensor	2/7/2011	Annual	2/7/2012	5442
Anritsu	ML2438A	Power Meter	2/7/2011	Annual	2/7/2012	1190013
Anritsu	ML2438A	Power Meter	2/7/2011	Annual	2/7/2012	98150041
Agilent	8648D	Signal Generator	4/5/2011	Annual	4/5/2012	3629U00687
Anritsu	ML2438A	Power Meter	2/7/2011	Annual	2/7/2012	1070030
Anritsu	MA2481A	Power Sensor	2/7/2011	Annual	2/7/2012	5821
Anritsu	MA2481A	Power Sensor	2/7/2011	Annual	2/7/2012	8013
Anritsu	MA2481A	Power Sensor	2/7/2011	Annual	2/7/2012	2400
Apriel	ALS-PR-DIEL	Dielectric Probe Kit	N/A		N/A	260-00959
Agilent	E5515C	Wireless Communications Test Set	8/13/2010	Annual	8/13/2011	GB43304447
Agilent	E5515C	Wireless Communications Tester	4/21/2011	Annual	4/21/2012	US41140256
Amplifier Research	5S1G4	5W, 800MHz-4.2GHz	N/A			17042
Mini-Circuits	BW-N20W5+	DC to 18 GHz Precision Fixed 20 dB Attenuator	N/A			N/A
Agilent	E5515C	Wireless Communications Test Set	2/8/2011	Annual	2/8/2012	GB45360985
Speag	D3700V2	3700 MHz SAR Dipole	2/16/2011	Annual	2/16/2012	1002
Rohde & Schwarz	CMW500	LTE Radio Communication Tester	3/11/2011	Annual	3/11/2012	103962
Control Company	61220-416	Long-Stem Thermometer	2/15/2011	Biennial	2/15/2013	111331322
Control Company	61220-416	Long-Stem Thermometer	2/15/2011	Biennial	2/15/2013	111331323
Control Company	61220-416	Long-Stem Thermometer	2/15/2011	Biennial	2/15/2013	111331330
Control Company	61220-416	Long-Stem Thermometer	2/15/2011	Biennial	2/15/2013	111331332
Control Company	61220-416	Long-Stem Thermometer	3/16/2011	Biennial	3/16/2013	111391601

FCC ID: A3LSCHI905	 PCTEST Engineering Laboratory, Inc.	SAR COMPLIANCE REPORT		Reviewed by: Quality Manager
Filename: OY1104190774-R1.A3L	Test Dates: 05/02/11 - 05/04/11	EUT Type: Cellular/PCS CDMA/EVDO and LTE Tablet with Bluetooth and WLAN		Page 40 of 50

# 19 MEASUREMENT UNCERTAINTIES

Applicable for 750 – 3000 MHz.

a	b	c	d	e= f(d,k)	f	g	h = c x f/e	i = c x g/e	k
Uncertainty Component	IEEE 1528 Sec.	Tol. (± %)	Prob. Dist.	Div.	c <sub>i</sub> 1gm	c <sub>i</sub> 10 gms	1gm u <sub>i</sub> (± %)	10gms u <sub>i</sub> (± %)	v <sub>i</sub>
<b>Measurement System</b>									
Probe Calibration	E.2.1	6.0	N	1	1.0	1.0	6.0	6.0	∞
Axial Isotropy	E.2.2	0.25	N	1	0.7	0.7	0.2	0.2	∞
Hemishperical Isotropy	E.2.2	1.3	N	1	1.0	1.0	1.3	1.3	∞
Boundary Effect	E.2.3	0.4	N	1	1.0	1.0	0.4	0.4	∞
Linearity	E.2.4	0.3	N	1	1.0	1.0	0.3	0.3	∞
System Detection Limits	E.2.5	5.1	N	1	1.0	1.0	5.1	5.1	∞
Readout Electronics	E.2.6	1.0	N	1	1.0	1.0	1.0	1.0	∞
Response Time	E.2.7	0.8	R	1.73	1.0	1.0	0.5	0.5	∞
Integration Time	E.2.8	2.6	R	1.73	1.0	1.0	1.5	1.5	∞
RF Ambient Conditions	E.6.1	3.0	R	1.73	1.0	1.0	1.7	1.7	∞
Probe Positioner Mechanical Tolerance	E.6.2	0.4	R	1.73	1.0	1.0	0.2	0.2	∞
Probe Positioning w/ respect to Phantom	E.6.3	2.9	R	1.73	1.0	1.0	1.7	1.7	∞
Extrapolation, Interpolation & Integration algorithms for Max. SAR Evaluation	E.5	1.0	R	1.73	1.0	1.0	0.6	0.6	∞
<b>Test Sample Related</b>									
Test Sample Positioning	E.4.2	6.0	N	1	1.0	1.0	6.0	6.0	287
Device Holder Uncertainty	E.4.1	3.32	R	1.73	1.0	1.0	1.9	1.9	∞
Output Power Variation - SAR drift measurement	6.6.2	5.0	R	1.73	1.0	1.0	2.9	2.9	∞
<b>Phantom &amp; Tissue Parameters</b>									
Phantom Uncertainty (Shape & Thickness tolerances)	E.3.1	4.0	R	1.73	1.0	1.0	2.3	2.3	∞
Liquid Conductivity - deviation from target values	E.3.2	5.0	R	1.73	0.64	0.43	1.8	1.2	∞
Liquid Conductivity - measurement uncertainty	E.3.3	3.8	N	1	0.64	0.43	2.4	1.6	6
Liquid Permittivity - deviation from target values	E.3.2	5.0	R	1.73	0.60	0.49	1.7	1.4	∞
Liquid Permittivity - measurement uncertainty	E.3.3	4.5	N	1	0.60	0.49	2.7	2.2	6
<b>Combined Standard Uncertainty (k=1)</b>				RSS			12.1	11.7	299
<b>Expanded Uncertainty (95% CONFIDENCE LEVEL)</b>				k=2			24.2	23.5	

The above measurement uncertainties are according to IEEE Std. 1528-2003

FCC ID: A3LSCHI905	 PCTEST ENGINEERING LABORATORY, INC.	SAR COMPLIANCE REPORT		Reviewed by: Quality Manager
Filename: 0Y1104190774-R1.A3L	Test Dates: 05/02/11 - 05/04/11	EUT Type: Cellular/PCS CDMA/EVDO and LTE Tablet with Bluetooth and WLAN		Page 41 of 50

Applicable for 5 GHz:

a	b	c	d	e= f(d,k)	f	g	h = c x f/e	i = c x g/e	k	
Uncertainty Component	IEEE 1528 Sec.	Tol. (± %)	Prob. Dist.	Div.	c <sub>i</sub> 1gm	c <sub>i</sub> 10 gms	1gm u <sub>i</sub> (± %)	10gms u <sub>i</sub> (± %)	v <sub>i</sub>	
<b>Measurement System</b>										
Probe Calibration	E.2.1	6.55	N	1	1.0	1.0	6.6	6.6	∞	
Axial Isotropy	E.2.2	0.25	N	1	0.7	0.7	0.2	0.2	∞	
Hemishperical Isotropy	E.2.2	1.3	N	1	1.0	1.0	1.3	1.3	∞	
Boundary Effect	E.2.3	0.4	N	1	1.0	1.0	0.4	0.4	∞	
Linearity	E.2.4	0.3	N	1	1.0	1.0	0.3	0.3	∞	
System Detection Limits	E.2.5	5.1	N	1	1.0	1.0	5.1	5.1	∞	
Readout Electronics	E.2.6	1.0	N	1	1.0	1.0	1.0	1.0	∞	
Response Time	E.2.7	0.8	R	1.73	1.0	1.0	0.5	0.5	∞	
Integration Time	E.2.8	2.6	R	1.73	1.0	1.0	1.5	1.5	∞	
RF Ambient Conditions	E.6.1	3.0	R	1.73	1.0	1.0	1.7	1.7	∞	
Probe Positioner Mechanical Tolerance	E.6.2	0.4	R	1.73	1.0	1.0	0.2	0.2	∞	
Probe Positioning w/ respect to Phantom	E.6.3	2.9	R	1.73	1.0	1.0	1.7	1.7	∞	
Extrapolation, Interpolation & Integration algorithms for Max. SAR Evaluation	E.5	1.0	R	1.73	1.0	1.0	0.6	0.6	∞	
<b>Test Sample Related</b>										
Test Sample Positioning	E.4.2	6.0	N	1	1.0	1.0	6.0	6.0	287	
Device Holder Uncertainty	E.4.1	3.32	R	1.73	1.0	1.0	1.9	1.9	∞	
Output Power Variation - SAR drift measurement	6.6.2	5.0	R	1.73	1.0	1.0	2.9	2.9	∞	
<b>Phantom &amp; Tissue Parameters</b>										
Phantom Uncertainty (Shape & Thickness tolerances)	E.3.1	4.0	R	1.73	1.0	1.0	2.3	2.3	∞	
Liquid Conductivity - deviation from target values	E.3.2	5.0	R	1.73	0.64	0.43	1.8	1.2	∞	
Liquid Conductivity - measurement uncertainty	E.3.3	3.8	N	1	0.64	0.43	2.4	1.6	6	
Liquid Permittivity - deviation from target values	E.3.2	5.0	R	1.73	0.60	0.49	1.7	1.4	∞	
Liquid Permittivity - measurement uncertainty	E.3.3	4.5	N	1	0.60	0.49	2.7	2.2	6	
<b>Combined Standard Uncertainty (k=1)</b>							RSS	12.4	12.0	299
<b>Expanded Uncertainty</b> (95% CONFIDENCE LEVEL)							k=2	24.7	24.0	

The above measurement uncertainties are according to IEEE Std. 1528-2003

FCC ID: A3LSCHI905	 PCTEST ENGINEERING LABORATORY, INC.	SAR COMPLIANCE REPORT		Reviewed by: Quality Manager
Filename: 0Y1104190774-R1.A3L	Test Dates: 05/02/11 - 05/04/11	EUT Type: Cellular/PCS CDMA/EVDO and LTE Tablet with Bluetooth and WLAN		Page 42 of 50

### 20.1 Measurement Conclusion

The SAR evaluation indicates that the EUT complies with the RF radiation exposure limits of the FCC and Industry Canada, with respect to all parameters subject to this test. These measurements were taken to simulate the RF effects of RF exposure under worst-case conditions. Precise laboratory measures were taken to assure repeatability of the tests. The results and statements relate only to the item(s) tested.

Please note that the absorption and distribution of electromagnetic energy in the body are very complex phenomena that depend on the mass, shape, and size of the body, the orientation of the body with respect to the field vectors, and the electrical properties of both the body and the environment. Other variables that may play a substantial role in possible biological effects are those that characterize the environment (e.g. ambient temperature, air velocity, relative humidity, and body insulation) and those that characterize the individual (e.g. age, gender, activity level, debilitation, or disease). Because various factors may interact with one another to vary the specific biological outcome of an exposure to electromagnetic fields, any protection guide should consider maximal amplification of biological effects as a result of field-body interactions, environmental conditions, and physiological variables. [3]

<b>FCC ID:</b> A3LSCHI905		<b>SAR COMPLIANCE REPORT</b>		<b>Reviewed by:</b> Quality Manager
<b>Filename:</b> 0Y1104190774-R1.A3L	<b>Test Dates:</b> 05/02/11 - 05/04/11	<b>EUT Type:</b> Cellular/PCS CDMA/EVDO and LTE Tablet with Bluetooth and WLAN		Page 43 of 50

## 21 REFERENCES

- [1] Federal Communications Commission, ET Docket 93-62, Guidelines for Evaluating the Environmental Effects of Radiofrequency Radiation, Aug. 1996.
- [2] ANSI/IEEE C95.1-2005, American National Standard safety levels with respect to human exposure to radio frequency electromagnetic fields, 300kHz to 100GHz, New York: IEEE, 2006.
- [3] ANSI/IEEE C95.1-1992, American National Standard safety levels with respect to human exposure to radio frequency electromagnetic fields, 300kHz to 100GHz, New York: IEEE, Sept. 1992.
- [4] ANSI/IEEE C95.3-2002, IEEE Recommended Practice for the Measurement of Potentially Hazardous Electromagnetic Fields - RF and Microwave, New York: IEEE, December 2002.
- [5] Federal Communications Commission, OET Bulletin 65 (Edition 97-01), Supplement C (Edition 01-01), Evaluating Compliance with FCC Guidelines for Human Exposure to Radiofrequency Electromagnetic Fields, June 2001.
- [6] IEEE Standards Coordinating Committee 34 – IEEE Std. 1528-2003, Recommended Practice for Determining the Peak Spatial-Average Specific Absorption Rate (SAR) in the Human Body Due to Wireless Communications Devices.
- [7] NCRP, National Council on Radiation Protection and Measurements, Biological Effects and Exposure Criteria for RadioFrequency Electromagnetic Fields, NCRP Report No. 86, 1986. Reprinted Feb. 1995.
- [8] T. Schmid, O. Egger, N. Kuster, Automated E-field scanning system for dosimetric assessments, IEEE Transaction on Microwave Theory and Techniques, vol. 44, Jan. 1996, pp. 105-113.
- [9] K. Pokovic, T. Schmid, N. Kuster, Robust setup for precise calibration of E-field probes in tissue simulating liquids at mobile communications frequencies, ICECOM97, Oct. 1997, pp. 120-124.
- [10] K. Pokovic, T. Schmid, and N. Kuster, E-field Probe with improved isotropy in brain simulating liquids, Proceedings of the ELMAR, Zadar, Croatia, June 23-25, 1996, pp. 172-175.
- [11] Schmid & Partner Engineering AG, Application Note: Data Storage and Evaluation, June 1998, p2.
- [12] V. Hombach, K. Meier, M. Burkhardt, E. Kuhn, N. Kuster, The Dependence of EM Energy Absorption upon Human Head Modeling at 900 MHz, IEEE Transaction on Microwave Theory and Techniques, vol. 44 no. 10, Oct. 1996, pp. 1865-1873.
- [13] N. Kuster and Q. Balzano, Energy absorption mechanism by biological bodies in the near field of dipole antennas above 300MHz, IEEE Transaction on Vehicular Technology, vol. 41, no. 1, Feb. 1992, pp. 17-23.
- [14] G. Hartsgrrove, A. Kraszewski, A. Surowiec, Simulated Biological Materials for Electromagnetic Radiation Absorption Studies, University of Ottawa, Bioelectromagnetics, Canada: 1987, pp. 29-36.
- [15] Q. Balzano, O. Garay, T. Manning Jr., Electromagnetic Energy Exposure of Simulated Users of Portable Cellular Telephones, IEEE Transactions on Vehicular Technology, vol. 44, no.3, Aug. 1995.
- [16] W. Gander, Computermathematik, Birkhaeuser, Basel, 1992.
- [17] W.H. Press, S.A. Teukolsky, W.T. Vetterling, and B.P. Flannery, Numerical Receptions in C, The Art of Scientific Computing, Second edition, Cambridge University Press, 1992.

<b>FCC ID:</b> A3LSCHI905		<b>SAR COMPLIANCE REPORT</b>		<b>Reviewed by:</b> Quality Manager
<b>Filename:</b> 0Y1104190774-R1.A3L	<b>Test Dates:</b> 05/02/11 - 05/04/11	<b>EUT Type:</b> Cellular/PCS CDMA/EVDO and LTE Tablet with Bluetooth and WLAN		Page 44 of 50

- [18] Federal Communications Commission, OET Bulletin 65, Evaluating Compliance with FCC Guidelines for Human Exposure to Radiofrequency Electromagnetic Fields. Supplement C, Dec. 1997.
- [19] N. Kuster, R. Kastle, T. Schmid, Dosimetric evaluation of mobile communications equipment with known precision, IEEE Transaction on Communications, vol. E80-B, no. 5, May 1997, pp. 645-652.
- [20] CENELEC CLC/SC111B, European Prestandard (prENV 50166-2), Human Exposure to Electromagnetic Fields High-frequency: 10kHz-300GHz, Jan. 1995.
- [21] Prof. Dr. Niels Kuster, ETH, Eidgenössische Technische Hochschule Zürich, Dosimetric Evaluation of the Cellular Phone.
- [22] IEC 62209-1, Human exposure to radio frequency fields from hand-held and body-mounted wireless communication devices - Human models, instrumentation, and procedures - Part 1: Procedure to determine the specific absorption rate (SAR) for hand-held devices used in close proximity to the ear (frequency range of 300 MHz to 3 GHz), Feb. 2005.
- [23] Industry Canada RSS-102 Radio Frequency Exposure Compliance of Radiocommunication Apparatus (All Frequency Bands) Issue 4, March 2010.
- [24] Health Canada Safety Code 6 Limits of Human Exposure to Radio Frequency Electromagnetic Fields in the Frequency Range from 3 kHz – 300 GHz, 2009
- [25] FCC Public Notice DA-02-1438. Office of Engineering and Technology Announces a Transition Period for the Phantom Requirements of Supplement C to OET Bulletin 65, June 19, 2002
- [26] FCC SAR Measurement Procedures for 3G Devices KDB Publication 941225
- [27] SAR Measurement procedures for IEEE 802.11a/b/g KDB Publication 248227
- [28] FCC SAR Considerations for Handsets with Multiple Transmitters and Antennas, KDB Publication 648474
- [29] FCC Application Note for SAR Probe Calibration and System Verification Consideration for Measurements at 150 MHz – 3 GHz, KDB Publication 450824
- [30] FCC SAR Evaluation Considerations for Laptop Computers with Antennas Built-in on Display Screens, KDB Publication 616217
- [31] FCC SAR Measurement Requirements for 3 – 6 GHz, KDB Publication 865664
- [32] FCC Mobile Portable RF Exposure Procedure, KDB Publication 447498
- [33] FCC SAR Procedures for Dongle Transmitters, KDB Publication 447498
- [34] Anexo à Resolução No. 533, de 10 de Setembro de 2009.
- [35] FCC SAR Test Considerations for LTE Handsets and Data Modems, KDB Publication 941225.
- [36] IEC 62209-2, Human exposure to radio frequency fields from hand-held and body-mounted wireless communication devices - Human models, instrumentation, and procedures - Part 2: Procedure to determine the specific absorption rate (SAR) for wireless communication devices used in close proximity to the human body (frequency range of 30 MHz to 6 GHz), Mar. 2010.
- [37] FCC Hot Spot SAR v01, KDB Publication 941225 D06.

<b>FCC ID:</b> A3LSCHI905	 <b>PCTEST</b> ENGINEERING LABORATORY, INC.	<b>SAR COMPLIANCE REPORT</b>		<b>Reviewed by:</b> Quality Manager
<b>Filename:</b> 0Y1104190774-R1.A3L	<b>Test Dates:</b> 05/02/11 - 05/04/11	<b>EUT Type:</b> Cellular/PCS CDMA/EVDO and LTE Tablet with Bluetooth and WLAN	Page 45 of 50	

## **APPENDIX A: SAR TEST DATA**

# PCTEST ENGINEERING LABORATORY, INC.

**DUT: A3LSCHI905; Type: Cellular/PCS CDMA/EVDO and LTE Tablet with Bluetooth and WLAN; Serial: FCC #2**

Communication System: LTE RF; Frequency: 782 MHz; Duty Cycle: 1:1

Medium: 785 Body Medium parameters used (interpolated):

$$f = 782 \text{ MHz}; \sigma = 1 \text{ mho/m}; \epsilon_r = 56; \rho = 1000 \text{ kg/m}^3$$

Phantom section: Flat Section; Space: 0.0 cm

Test Date: 05-03-2011; Ambient Temp: 23.4 °C; Tissue Temp: 21.8 °C

Probe: ES3DV2 - SN3022; ConvF(6.09, 6.09, 6.09); Calibrated: 9/21/2010

Sensor-Surface: 4mm (Mechanical Surface Detection)

Electronics: DAE4 Sn704; Calibrated: 3/17/2011

Phantom: SAM with CRP; Type: SAM; Serial: TP1375

Measurement SW: DASY4, V4.7 Build 80; Postprocessing SW: SEMCAD, V1.8 Build 186

**Mode: LTE, Body SAR, Back side, Mid.ch, 16 QAM, 1 RBs, RB Offset 49**

**Area Scan (7x19x1):** Measurement grid: dx=15mm, dy=15mm

**Zoom Scan (5x5x7)/Cube 0:** Measurement grid: dx=8mm, dy=8mm, dz=5mm

Reference Value = 25.9 V/m

Peak SAR (extrapolated) = 1.32 W/kg

SAR(1 g) = 0.642 mW/g; SAR(10 g) = 0.327 mW/g

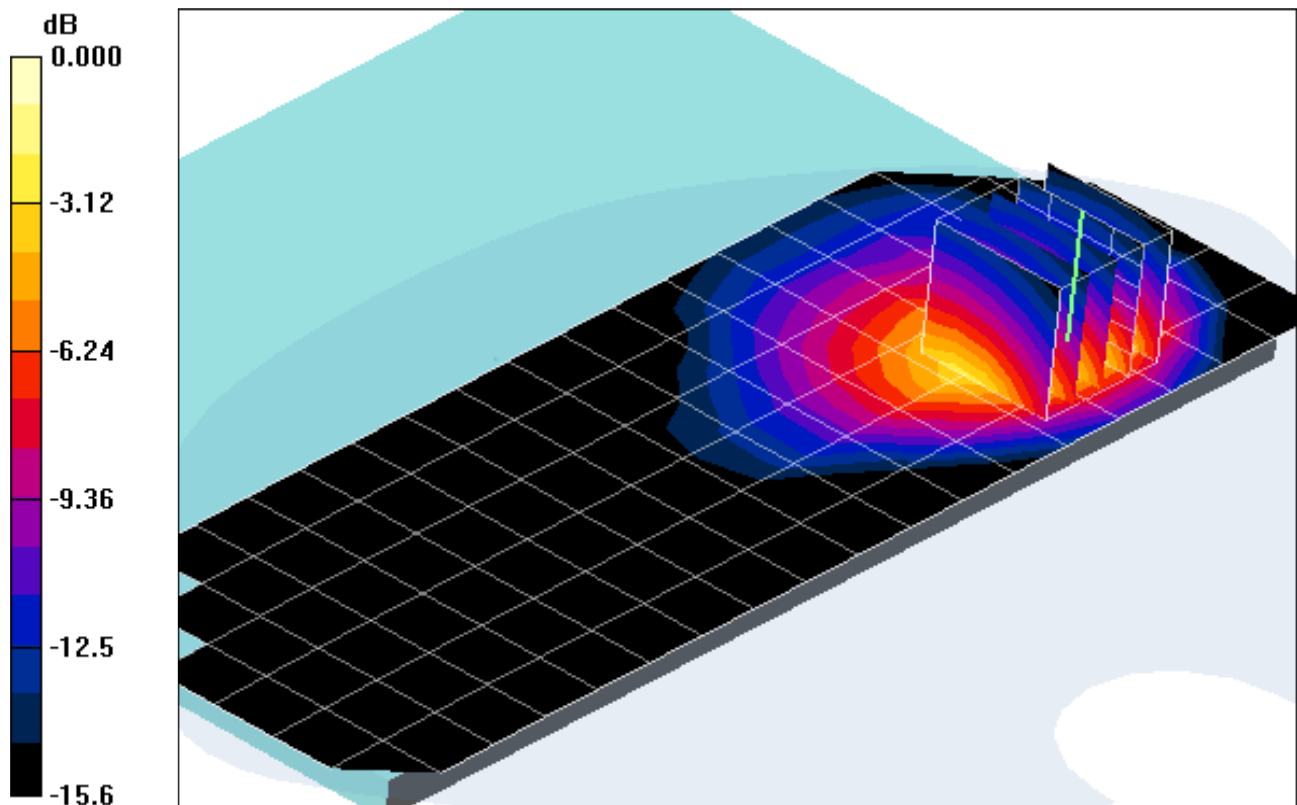

0 dB = 0.771mW/g

# PCTEST ENGINEERING LABORATORY, INC.

**DUT: A3LSCHI905; Type: Cellular/PCS CDMA/EVDO and LTE Tablet with Bluetooth and WLAN; Serial: FCC #1**

Communication System: LTE RF; Frequency: 782 MHz; Duty Cycle: 1:1

Medium: 785 Body Medium parameters used (interpolated):

$$f = 782 \text{ MHz}; \sigma = 1 \text{ mho/m}; \epsilon_r = 56; \rho = 1000 \text{ kg/m}^3$$

Phantom section: Flat Section; Space: 0.0 cm

Test Date: 05-03-2011; Ambient Temp: 23.4 °C; Tissue Temp: 21.8 °C

Probe: ES3DV2 - SN3022; ConvF(6.09, 6.09, 6.09); Calibrated: 9/21/2010

Sensor-Surface: 4mm (Mechanical Surface Detection)

Electronics: DAE4 Sn704; Calibrated: 3/17/2011

Phantom: SAM with CRP; Type: SAM; Serial: TP1375

Measurement SW: DASY4, V4.7 Build 80; Postprocessing SW: SEMCAD, V1.8 Build 186

**Mode: LTE, Body SAR, Top Edge, Mid.ch, QPSK, 1 RBs, RB Offset 0**

**Area Scan (5x19x1):** Measurement grid: dx=15mm, dy=15mm

**Zoom Scan (5x5x7)/Cube 0:** Measurement grid: dx=8mm, dy=8mm, dz=5mm

Reference Value = 39.2 V/m

Peak SAR (extrapolated) = 2.20 W/kg

SAR(1 g) = 1.05 mW/g; SAR(10 g) = 0.528 mW/g

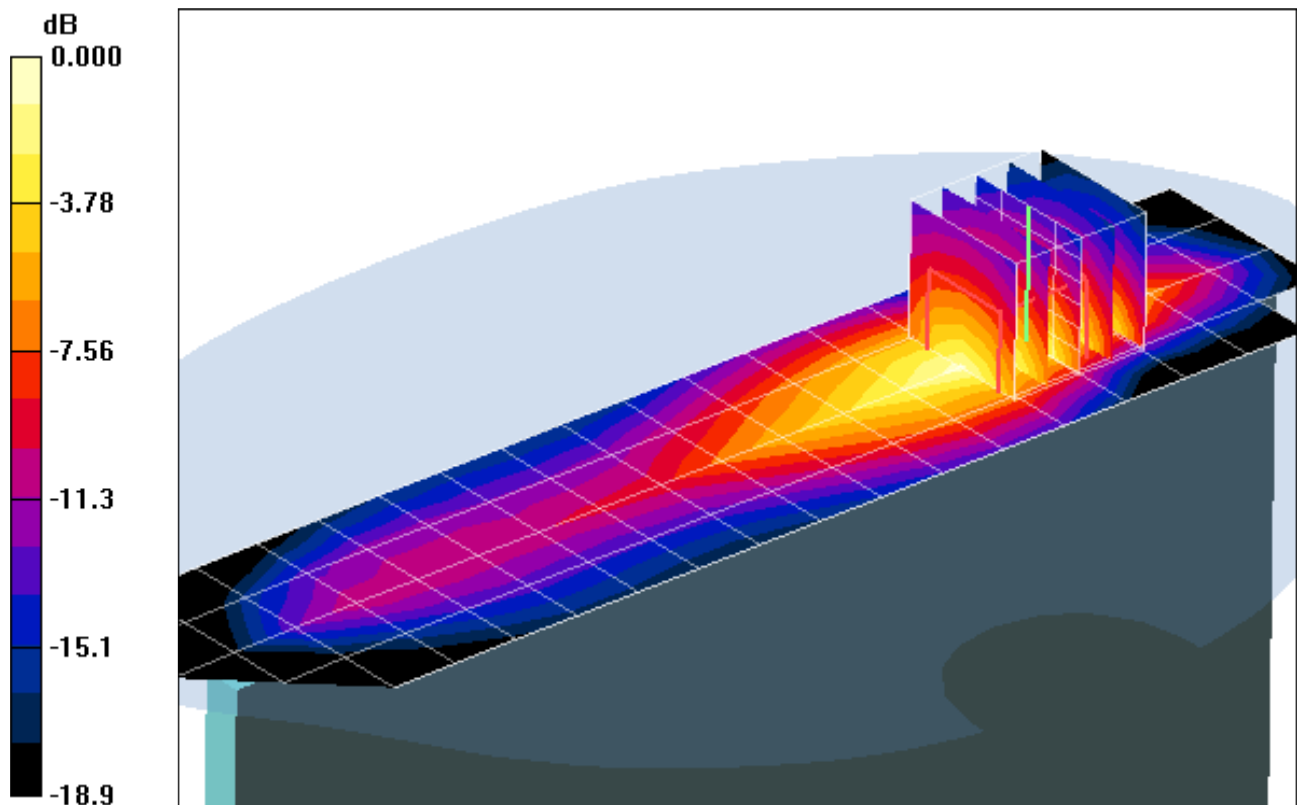

0 dB = 1.27mW/g

# PCTEST ENGINEERING LABORATORY, INC.

**DUT: A3LSCHI905; Type: Cellular/PCS CDMA/EVDO and LTE Tablet  
with Bluetooth and WLAN; Serial: FCC #1**

Communication System: LTE RF; Frequency: 782 MHz; Duty Cycle: 1:1

Medium: 785 Body Medium parameters used (interpolated):

$$f = 782 \text{ MHz}; \sigma = 1 \text{ mho/m}; \epsilon_r = 56; \rho = 1000 \text{ kg/m}^3$$

Phantom section: Flat Section; Space: 0.0 cm

Test Date: 05-03-2011; Ambient Temp: 23.4 °C; Tissue Temp: 21.8 °C

Probe: ES3DV2 - SN3022; ConvF(6.09, 6.09, 6.09); Calibrated: 9/21/2010

Sensor-Surface: 4mm (Mechanical Surface Detection)

Electronics: DAE4 Sn704; Calibrated: 3/17/2011

Phantom: SAM with CRP; Type: SAM; Serial: TP1375

Measurement SW: DASY4, V4.7 Build 80; Postprocessing SW: SEMCAD, V1.8 Build 186

**Mode: LTE, Body SAR, Top Edge, Mid.ch, QPSK, 1 RBs, RB Offset 0**

**Area Scan (5x19x1):** Measurement grid: dx=15mm, dy=15mm

**Zoom Scan (5x5x7)/Cube 0:** Measurement grid: dx=8mm, dy=8mm, dz=5mm

Reference Value = 39.2 V/m

Peak SAR (extrapolated) = 2.20 W/kg

**SAR(1 g) = 1.05 mW/g; SAR(10 g) = 0.528 mW/g**

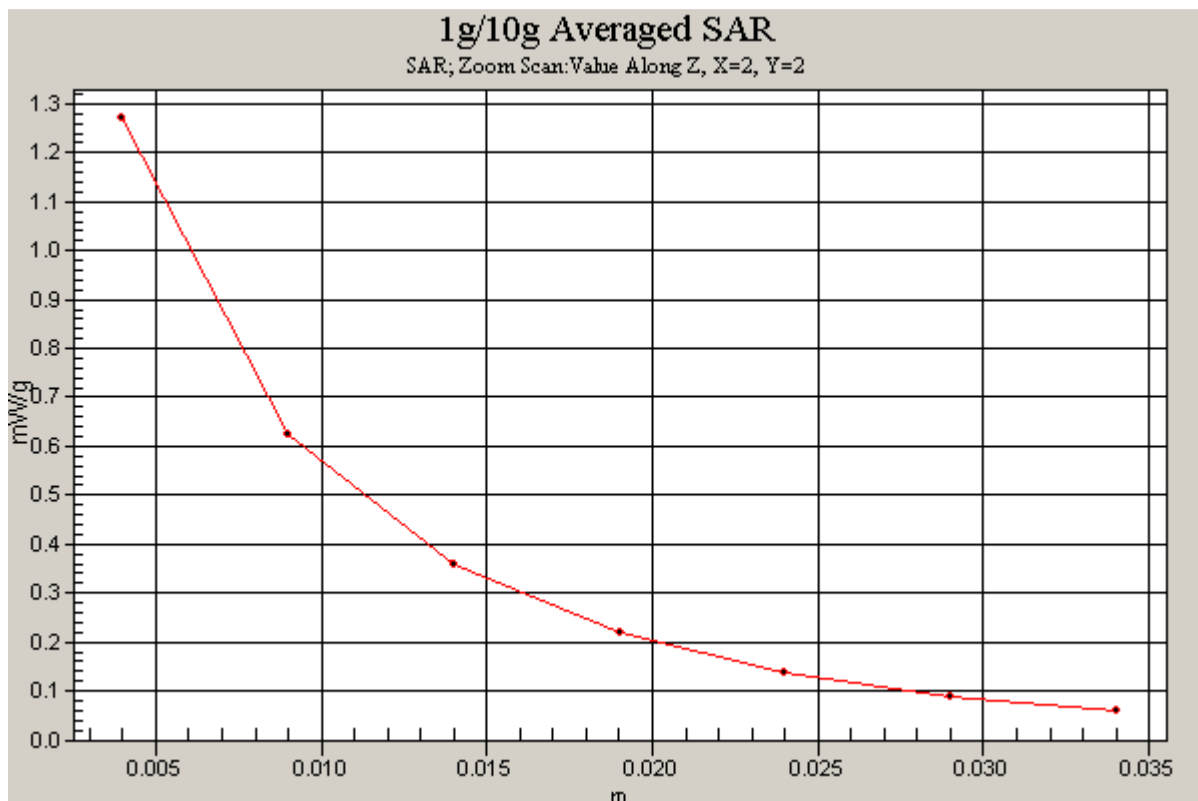

# PCTEST ENGINEERING LABORATORY, INC.

**DUT: A3LSCHI905; Type: Cellular/PCS CDMA/EVDO and LTE Tablet  
with Bluetooth and WLAN; Serial: FCC #1**

Communication System: LTE RF; Frequency: 782 MHz; Duty Cycle: 1:1

Medium: 785 Body Medium parameters used (interpolated):

$$f = 782 \text{ MHz}; \sigma = 1 \text{ mho/m}; \epsilon_r = 56; \rho = 1000 \text{ kg/m}^3$$

Phantom section: Flat Section; Space: 0.0 cm

Test Date: 05-03-2011; Ambient Temp: 23.4 °C; Tissue Temp: 21.8 °C

Probe: ES3DV2 - SN3022; ConvF(6.09, 6.09, 6.09); Calibrated: 9/21/2010

Sensor-Surface: 4mm (Mechanical Surface Detection)

Electronics: DAE4 Sn704; Calibrated: 3/17/2011

Phantom: SAM with CRP; Type: SAM; Serial: TP1375

Measurement SW: DASY4, V4.7 Build 80; Postprocessing SW: SEMCAD, V1.8 Build 186

**Mode: LTE, Body SAR, Right Edge, Mid.ch, QPSK, 1 RBs, RB Offset 0**

**Area Scan (5x19x1):** Measurement grid: dx=15mm, dy=15mm

**Zoom Scan (5x5x7)/Cube 0:** Measurement grid: dx=8mm, dy=8mm, dz=5mm

Reference Value = 14.2 V/m

Peak SAR (extrapolated) = 0.262 W/kg

**SAR(1 g) = 0.097 mW/g; SAR(10 g) = 0.041 mW/g**

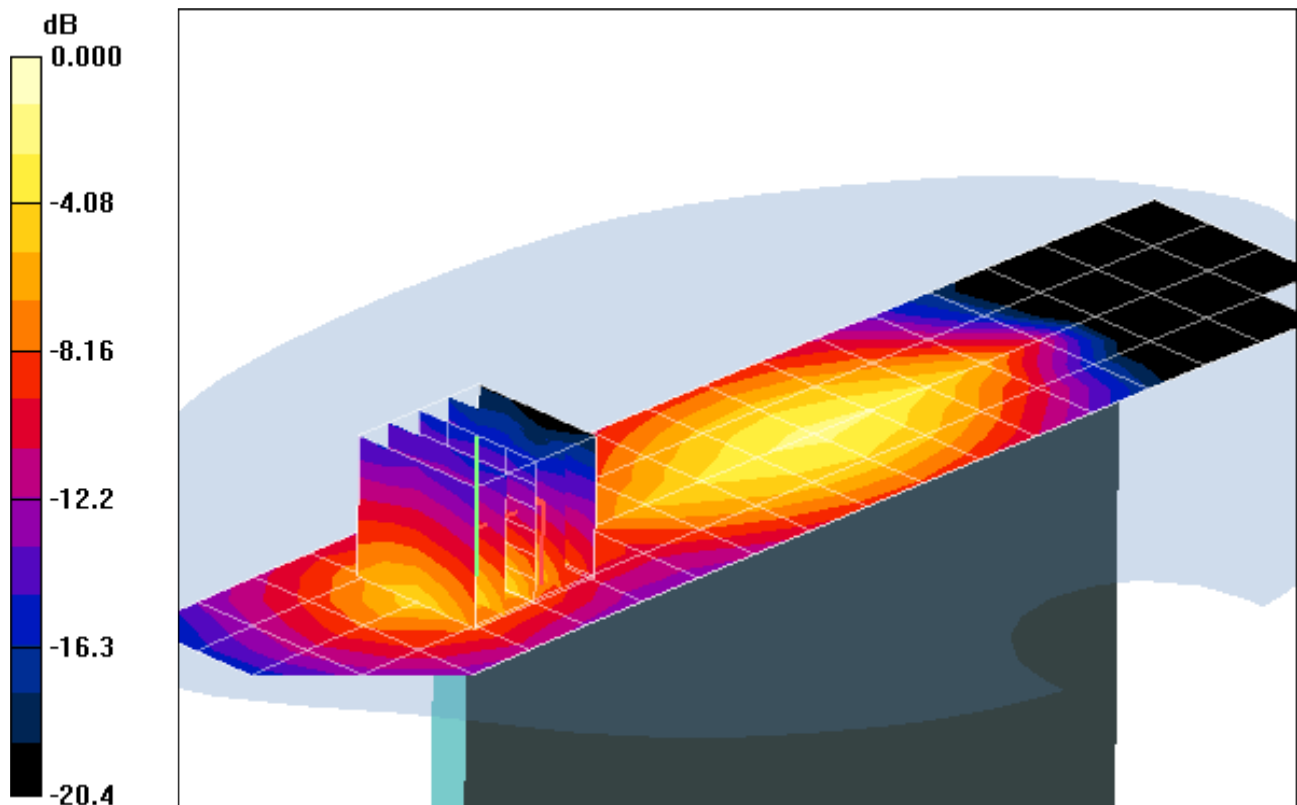

0 dB = 0.129mW/g

# PCTEST ENGINEERING LABORATORY, INC.

**DUT: A3LSCHI905; Type: Cellular/PCS CDMA/EVDO and LTE Tablet  
with Bluetooth and WLAN; Serial: FCC #2**

Communication System: Cellular CDMA; Frequency: 836.52 MHz; Duty Cycle: 1:1  
Medium: 835 Body Medium parameters used (interpolated):

$f = 836.52 \text{ MHz}$ ;  $\sigma = 0.958 \text{ mho/m}$ ;  $\epsilon_r = 53.13$ ;  $\rho = 1000 \text{ kg/m}^3$

Phantom section: Flat Section; Space: 0.0 cm

Test Date: 05-04-2011; Ambient Temp: 24.2 °C; Tissue Temp: 22.4 °C

Probe: EX3DV4 - SN3561; ConvF(8.09, 8.09, 8.09); Calibrated: 8/19/2010

Sensor-Surface: 4mm (Mechanical Surface Detection)

Electronics: DAE4 Sn649; Calibrated: 2/21/2011

Phantom: SAM Main; Type: SAM 4.0; Serial: TP-1406

Measurement SW: DASY4, V4.7 Build 80; Postprocessing SW: SEMCAD, V1.8 Build 186

**Mode: Cellular CDMA, EvDO Body SAR, Back side, Mid.ch**

**Area Scan (7x19x1):** Measurement grid: dx=15mm, dy=15mm

**Zoom Scan (5x5x7)/Cube 0:** Measurement grid: dx=8mm, dy=8mm, dz=5mm

Reference Value = 2.88 V/m

Peak SAR (extrapolated) = 1.34 W/kg

**SAR(1 g) = 0.669 mW/g; SAR(10 g) = 0.367 mW/g**

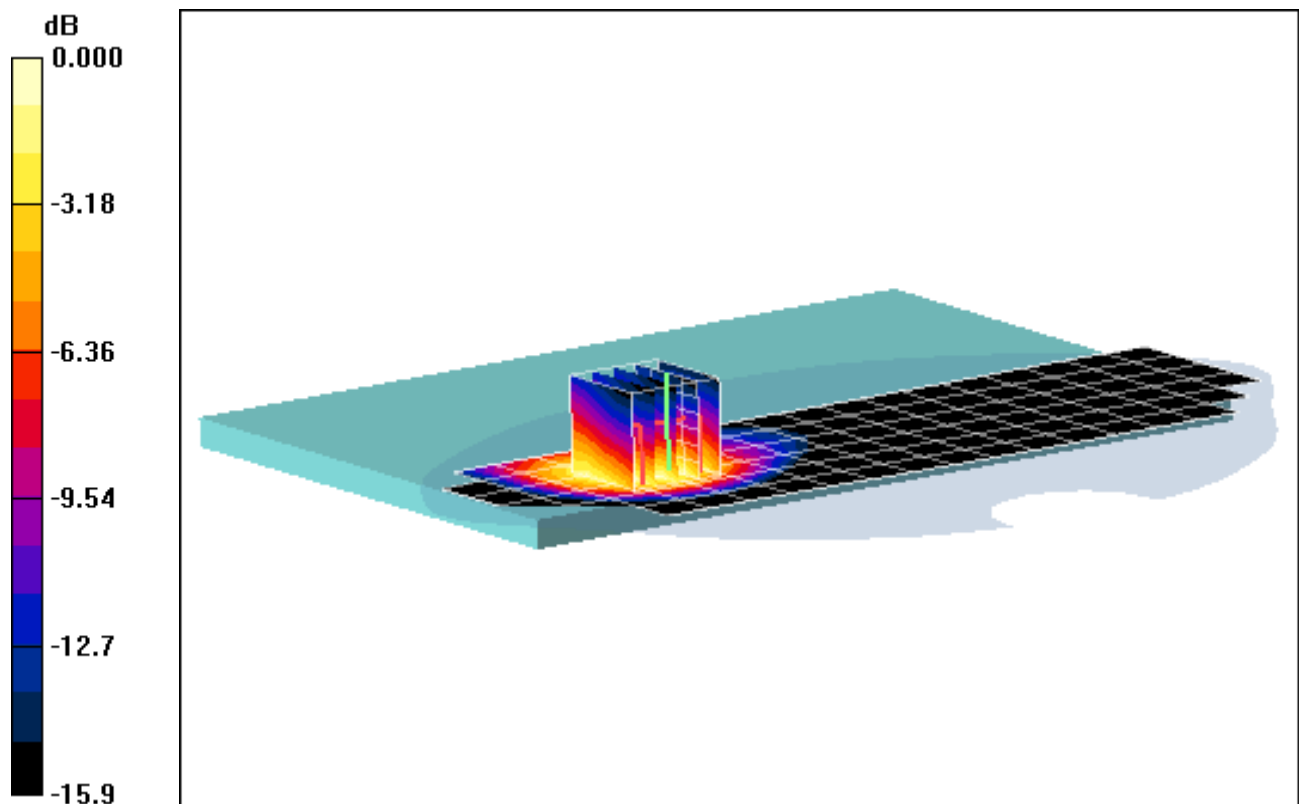

0 dB = 0.742mW/g

# PCTEST ENGINEERING LABORATORY, INC.

**DUT: A3LSCHI905; Type: Cellular/PCS CDMA/EVDO and LTE Tablet  
with Bluetooth and WLAN; Serial: FCC #2**

Communication System: Cellular CDMA; Frequency: 836.52 MHz; Duty Cycle: 1:1  
Medium: 835 Body Medium parameters used (interpolated):

$f = 836.52 \text{ MHz}$ ;  $\sigma = 0.958 \text{ mho/m}$ ;  $\epsilon_r = 53.13$ ;  $\rho = 1000 \text{ kg/m}^3$

Phantom section: Flat Section; Space: 0.0 cm

Test Date: 05-04-2011; Ambient Temp: 24.2 °C; Tissue Temp: 22.4 °C

Probe: EX3DV4 - SN3561; ConvF(8.09, 8.09, 8.09); Calibrated: 8/19/2010

Sensor-Surface: 4mm (Mechanical Surface Detection)

Electronics: DAE4 Sn649; Calibrated: 2/21/2011

Phantom: SAM Main; Type: SAM 4.0; Serial: TP-1406

Measurement SW: DASY4, V4.7 Build 80; Postprocessing SW: SEMCAD, V1.8 Build 186

**Mode: Cellular CDMA, EvDO Body SAR, Back side, Mid.ch**

**Area Scan (7x19x1):** Measurement grid: dx=15mm, dy=15mm

**Zoom Scan (5x5x7)/Cube 0:** Measurement grid: dx=8mm, dy=8mm, dz=5mm

Reference Value = 2.88 V/m

Peak SAR (extrapolated) = 1.34 W/kg

**SAR(1 g) = 0.669 mW/g; SAR(10 g) = 0.367 mW/g**

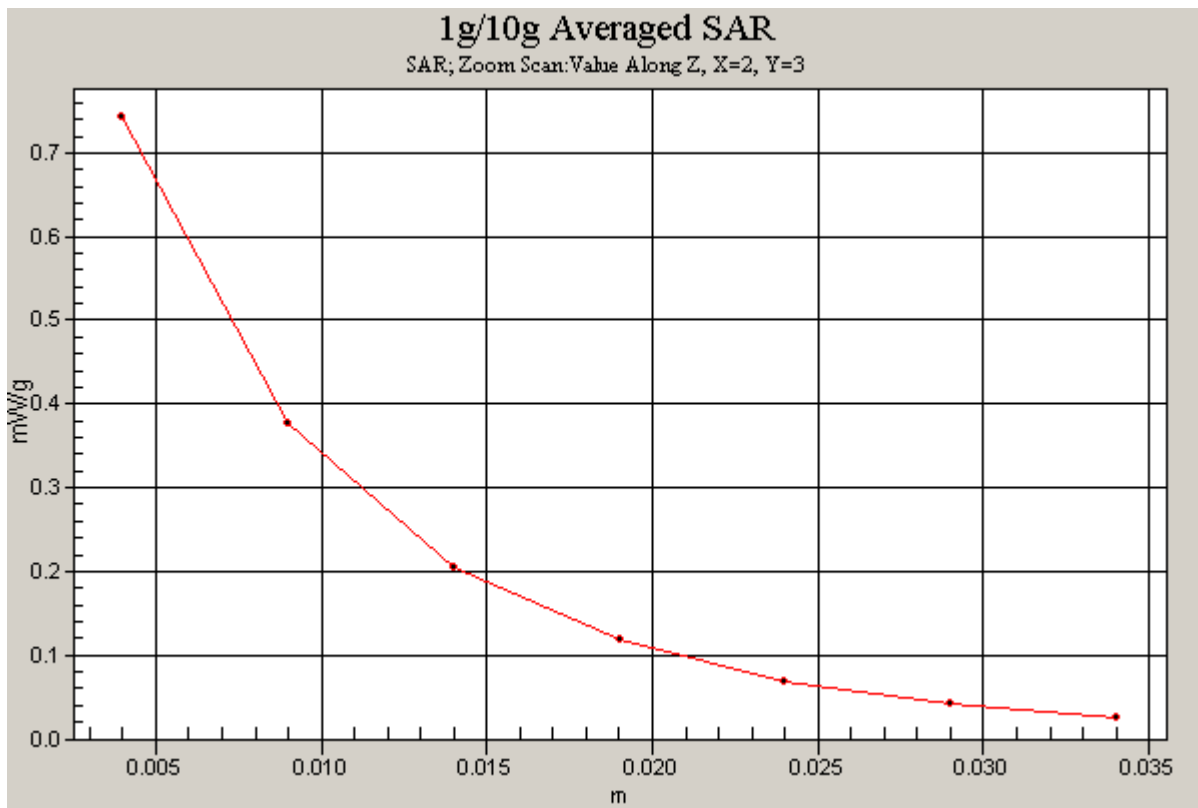

# PCTEST ENGINEERING LABORATORY, INC.

**DUT: A3LSCHI905; Type: Cellular/PCS CDMA/EVDO and LTE Tablet  
with Bluetooth and WLAN; Serial: FCC #1**

Communication System: Cellular CDMA; Frequency: 836.52 MHz; Duty Cycle: 1:1  
Medium: 835 Body Medium parameters used (interpolated):

$f = 836.52 \text{ MHz}$ ;  $\sigma = 0.958 \text{ mho/m}$ ;  $\epsilon_r = 53.13$ ;  $\rho = 1000 \text{ kg/m}^3$

Phantom section: Flat Section; Space: 0.5 cm

Test Date: 05-04-2011; Ambient Temp: 24.2 °C; Tissue Temp: 22.4 °C

Probe: EX3DV4 - SN3561; ConvF(8.09, 8.09, 8.09); Calibrated: 8/19/2010

Sensor-Surface: 4mm (Mechanical Surface Detection)

Electronics: DAE4 Sn649; Calibrated: 2/21/2011

Phantom: SAM Main; Type: SAM 4.0; Serial: TP-1406

Measurement SW: DASY4, V4.7 Build 80; Postprocessing SW: SEMCAD, V1.8 Build 186

**Mode: Cell CDMA EVDO, Body SAR, Top Edge, Mid.ch**

**Area Scan (5x19x1):** Measurement grid: dx=15mm, dy=15mm

**Zoom Scan (5x5x7)/Cube 0:** Measurement grid: dx=8mm, dy=8mm, dz=5mm

Reference Value = 9.33 V/m

Peak SAR (extrapolated) = 0.777 W/kg

**SAR(1 g) = 0.369 mW/g; SAR(10 g) = 0.183 mW/g**

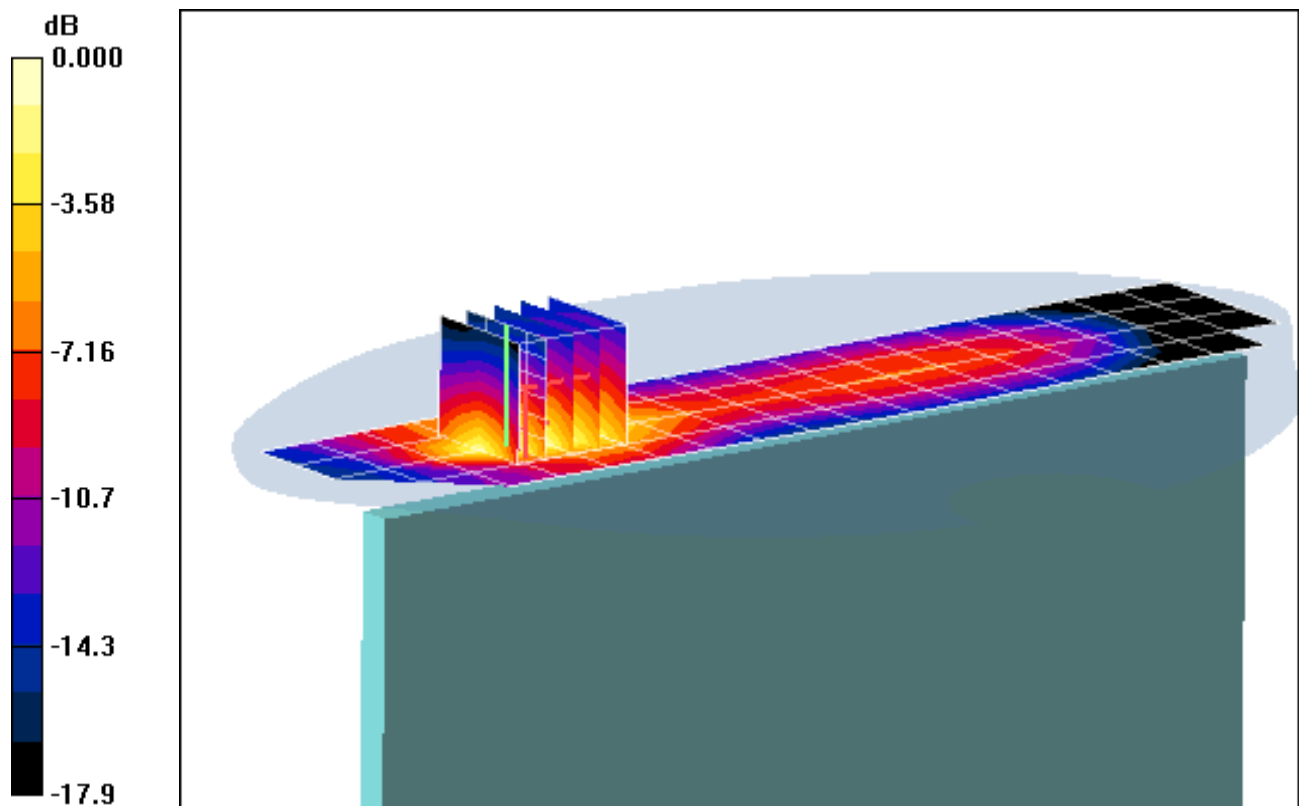

0 dB = 0.423mW/g

# PCTEST ENGINEERING LABORATORY, INC.

**DUT: A3LSCHI905; Type: Cellular/PCS CDMA/EVDO and LTE Tablet  
with Bluetooth and WLAN; Serial: FCC #1**

Communication System: Cellular CDMA; Frequency: 836.52 MHz; Duty Cycle: 1:1  
Medium: 835 Body Medium parameters used (interpolated):

$f = 836.52 \text{ MHz}$ ;  $\sigma = 0.958 \text{ mho/m}$ ;  $\epsilon_r = 53.13$ ;  $\rho = 1000 \text{ kg/m}^3$

Phantom section: Flat Section; Space: 0.0 cm

Test Date: 05-04-2011; Ambient Temp: 24.2 °C; Tissue Temp: 22.4 °C

Probe: EX3DV4 - SN3561; ConvF(8.09, 8.09, 8.09); Calibrated: 8/19/2010

Sensor-Surface: 4mm (Mechanical Surface Detection)

Electronics: DAE4 Sn649; Calibrated: 2/21/2011

Phantom: SAM Main; Type: SAM 4.0; Serial: TP-1406

Measurement SW: DASY4, V4.7 Build 80; Postprocessing SW: SEMCAD, V1.8 Build 186

**Mode: Cell CDMA EVDO, Body SAR, Left Edge, Mid.ch**

**Area Scan (5x14x1):** Measurement grid: dx=15mm, dy=15mm

**Zoom Scan (5x5x7)/Cube 0:** Measurement grid: dx=8mm, dy=8mm, dz=5mm

Reference Value = 23.4 V/m

Peak SAR (extrapolated) = 0.718 W/kg

**SAR(1 g) = 0.454 mW/g; SAR(10 g) = 0.290 mW/g**

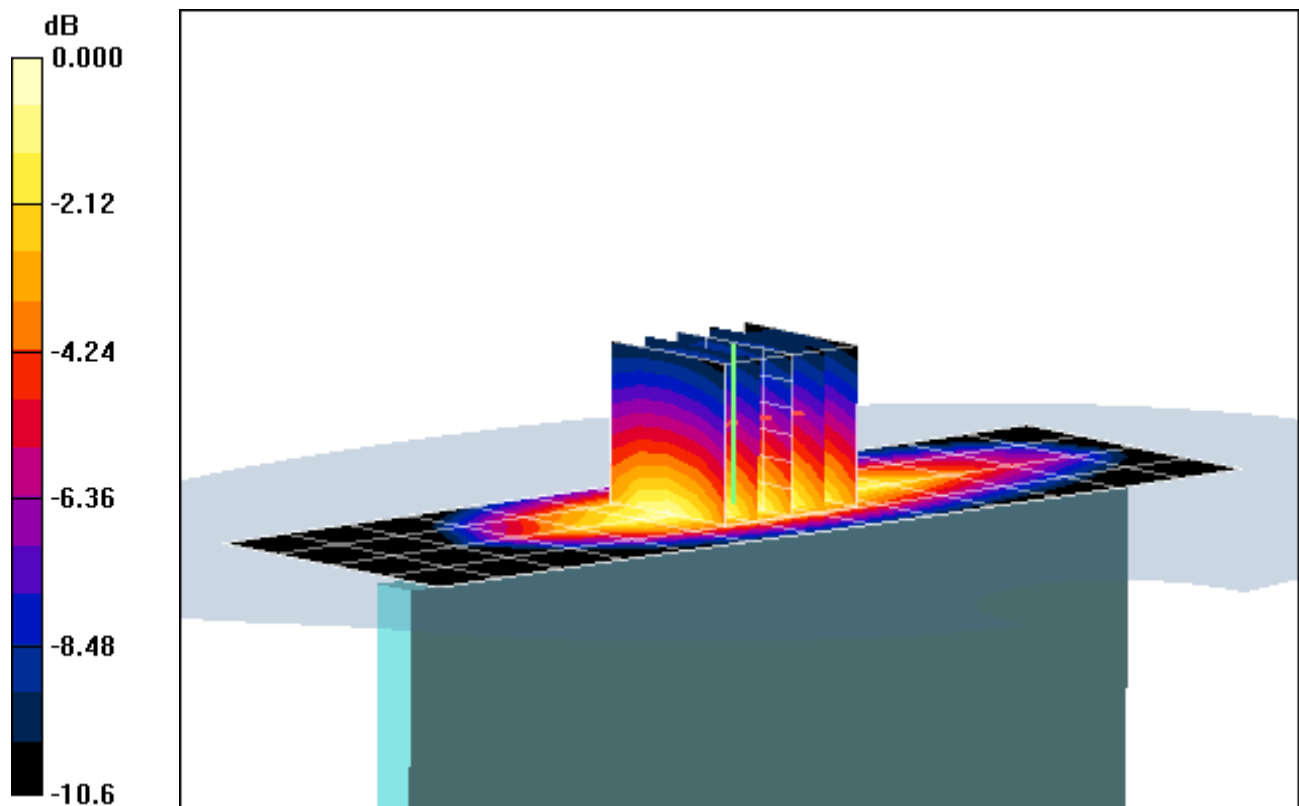

0 dB = 0.497mW/g

# PCTEST ENGINEERING LABORATORY, INC.

**DUT: A3LSCHI905; Type: Cellular/PCS CDMA/EVDO and LTE Tablet with Bluetooth and WLAN; Serial: FCC #2**

Communication System: PCS CDMA; Frequency: 1880 MHz; Duty Cycle: 1:1  
Medium: 1900 Body Medium parameters used:

$f = 1880 \text{ MHz}$ ;  $\sigma = 1.5 \text{ mho/m}$ ;  $\epsilon_r = 52.4$ ;  $\rho = 1000 \text{ kg/m}^3$

Phantom section: Flat Section; Space: 0.0 cm

Test Date: 05-02-2011; Ambient Temp: 24.0 °C; Tissue Temp: 22.8 °C

Probe: EX3DV4 - SN3561; ConvF(6.59, 6.59, 6.59); Calibrated: 8/19/2010

Sensor-Surface: 4mm (Mechanical Surface Detection)

Electronics: DAE4 Sn649; Calibrated: 2/21/2011

Phantom: SAM Sub; Type: SAM 4.0; Serial: TP-1357

Measurement SW: DASY4, V4.7 Build 80; Postprocessing SW: SEMCAD, V1.8 Build 186

**Mode: PCS CDMA, EvDO Body SAR, Back side, Mid.ch**

**Area Scan (7x19x1):** Measurement grid: dx=15mm, dy=15mm

**Zoom Scan (5x5x7)/Cube 0:** Measurement grid: dx=8mm, dy=8mm, dz=5mm

Reference Value = 1.88 V/m

Peak SAR (extrapolated) = 1.89 W/kg

**SAR(1 g) = 0.759 mW/g; SAR(10 g) = 0.337 mW/g**

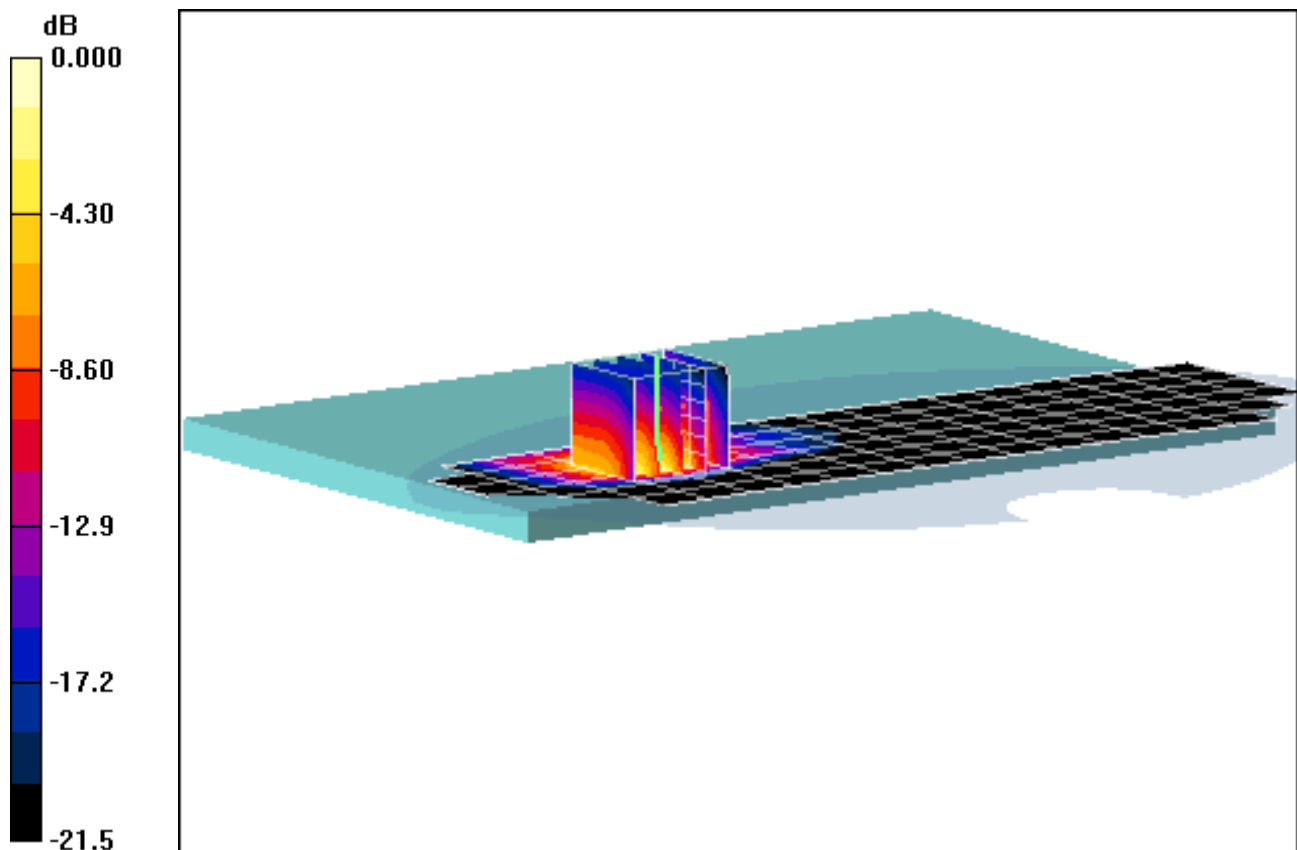

0 dB = 0.887mW/g

# PCTEST ENGINEERING LABORATORY, INC.

**DUT: A3LSCHI905; Type: Cellular/PCS CDMA/EVDO and LTE Tablet  
with Bluetooth and WLAN; Serial: FCC #2**

Communication System: PCS CDMA; Frequency: 1880 MHz; Duty Cycle: 1:1  
Medium: 1900 Body Medium parameters used:

$$f = 1880 \text{ MHz}; \sigma = 1.5 \text{ mho/m}; \epsilon_r = 52.4; \rho = 1000 \text{ kg/m}^3$$

Phantom section: Flat Section; Space: 0.0 cm

Test Date: 05-02-2011; Ambient Temp: 24.0 °C; Tissue Temp: 22.8 °C

Probe: EX3DV4 - SN3561; ConvF(6.59, 6.59, 6.59); Calibrated: 8/19/2010

Sensor-Surface: 4mm (Mechanical Surface Detection)

Electronics: DAE4 Sn649; Calibrated: 2/21/2011

Phantom: SAM Sub; Type: SAM 4.0; Serial: TP-1357

Measurement SW: DASY4, V4.7 Build 80; Postprocessing SW: SEMCAD, V1.8 Build 186

**Mode: PCS CDMA, EvDO Body SAR, Back side, Mid.ch**

**Area Scan (7x19x1):** Measurement grid: dx=15mm, dy=15mm

**Zoom Scan (5x5x7)/Cube 0:** Measurement grid: dx=8mm, dy=8mm, dz=5mm

Reference Value = 1.88 V/m

Peak SAR (extrapolated) = 1.89 W/kg

**SAR(1 g) = 0.759 mW/g; SAR(10 g) = 0.337 mW/g**

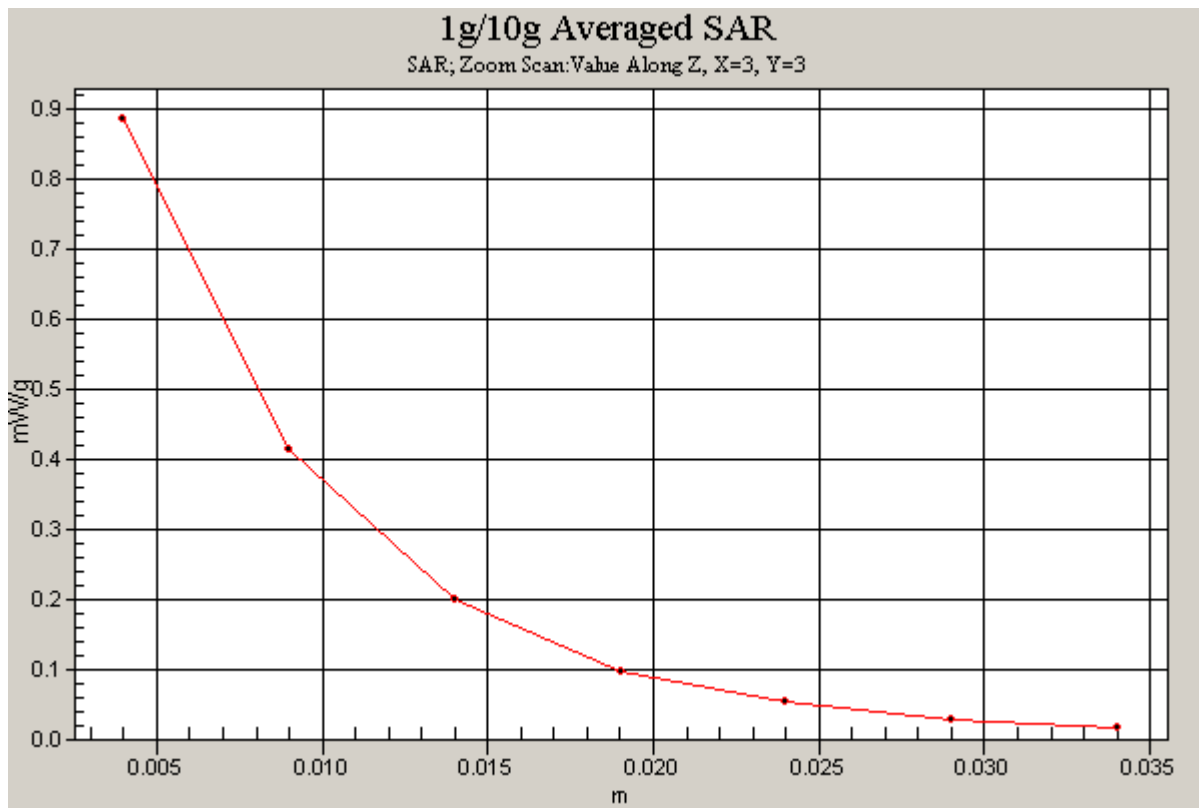

# PCTEST ENGINEERING LABORATORY, INC.

**DUT: A3LSCHI905; Type: Cellular/PCS CDMA/EVDO and LTE Tablet with Bluetooth and WLAN; Serial: FCC #1**

Communication System: PCS CDMA; Frequency: 1880 MHz; Duty Cycle: 1:1  
Medium: 1900 Body Medium parameters used:

$f = 1880 \text{ MHz}$ ;  $\sigma = 1.5 \text{ mho/m}$ ;  $\epsilon_r = 52.4$ ;  $\rho = 1000 \text{ kg/m}^3$

Phantom section: Flat Section; Space: 0.5 cm

Test Date: 05-02-2011; Ambient Temp: 24.0 °C; Tissue Temp: 22.8 °C

Probe: EX3DV4 - SN3561; ConvF(6.59, 6.59, 6.59); Calibrated: 8/19/2010

Sensor-Surface: 4mm (Mechanical Surface Detection)

Electronics: DAE4 Sn649; Calibrated: 2/21/2011

Phantom: SAM Sub; Type: SAM 4.0; Serial: TP-1357

Measurement SW: DASY4, V4.7 Build 80; Postprocessing SW: SEMCAD, V1.8 Build 186

**Mode: PCS CDMA, EVDO Body SAR, Top Edge, Mid.ch**

**Area Scan (5x19x1):** Measurement grid: dx=15mm, dy=15mm

**Zoom Scan (5x5x7)/Cube 0:** Measurement grid: dx=8mm, dy=8mm, dz=5mm

Reference Value = 21.7 V/m

Peak SAR (extrapolated) = 1.11 W/kg

**SAR(1 g) = 0.685 mW/g; SAR(10 g) = 0.393 mW/g**

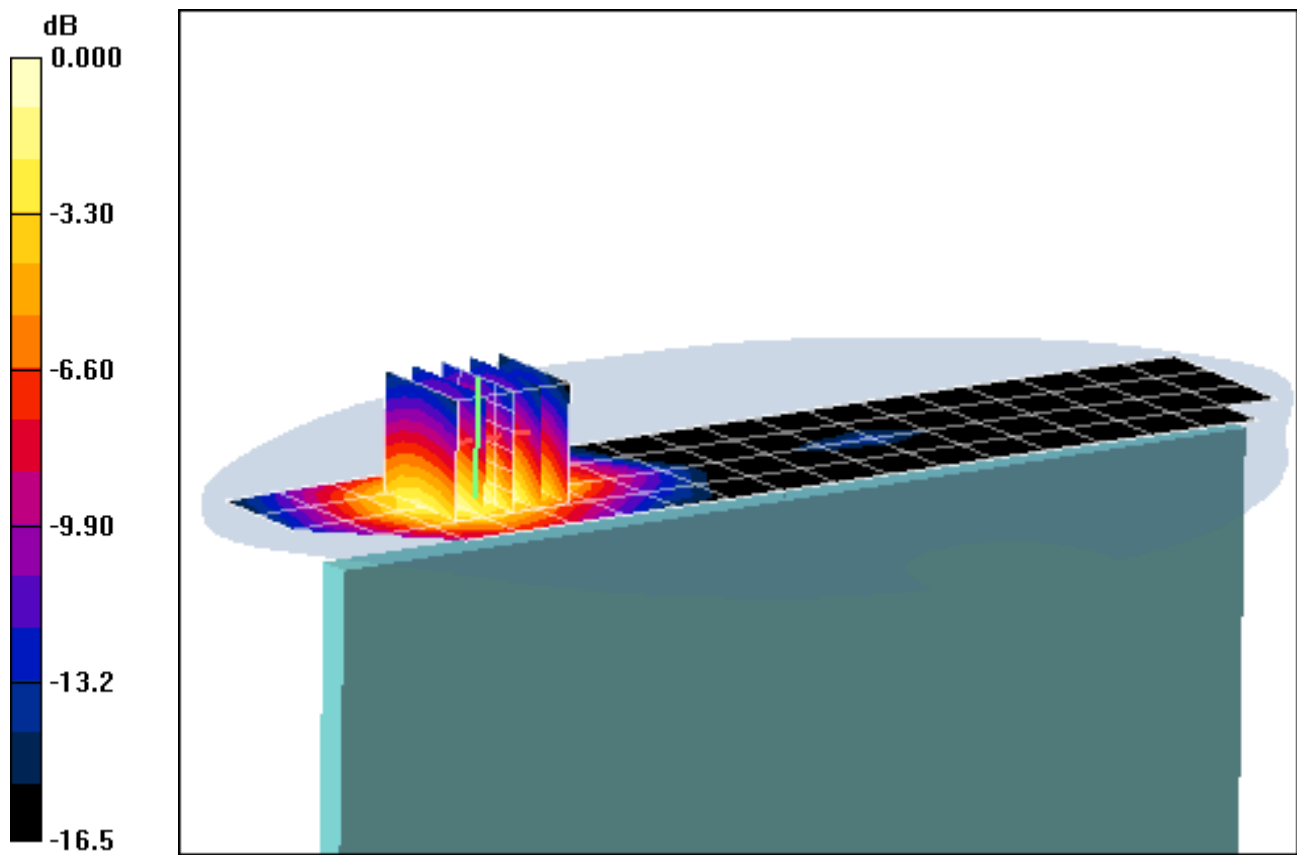

0 dB = 0.742mW/g

# PCTEST ENGINEERING LABORATORY, INC.

**DUT: A3LSCHI905; Type: Cellular/PCS CDMA/EVDO and LTE Tablet with Bluetooth and WLAN; Serial: FCC #1**

Communication System: PCS CDMA; Frequency: 1880 MHz; Duty Cycle: 1:1  
Medium: 1900 Body Medium parameters used:

$$f = 1880 \text{ MHz}; \sigma = 1.5 \text{ mho/m}; \epsilon_r = 52.4; \rho = 1000 \text{ kg/m}^3$$

Phantom section: Flat Section; Space: 0.0 cm

Test Date: 05-02-2011; Ambient Temp: 24.0 °C; Tissue Temp: 22.8 °C

Probe: EX3DV4 - SN3561; ConvF(6.59, 6.59, 6.59); Calibrated: 8/19/2010

Sensor-Surface: 4mm (Mechanical Surface Detection)

Electronics: DAE4 Sn649; Calibrated: 2/21/2011

Phantom: SAM Sub; Type: SAM 4.0; Serial: TP-1357

Measurement SW: DASY4, V4.7 Build 80; Postprocessing SW: SEMCAD, V1.8 Build 186

**Mode: PCS CDMA, EVDO Body SAR, Left Edge, Mid.ch**

**Area Scan (5x19x1):** Measurement grid: dx=15mm, dy=15mm

**Zoom Scan (5x5x7)/Cube 0:** Measurement grid: dx=8mm, dy=8mm, dz=5mm

Reference Value = 13.3 V/m

Peak SAR (extrapolated) = 0.379 W/kg

**SAR(1 g) = 0.214 mW/g; SAR(10 g) = 0.122 mW/g**

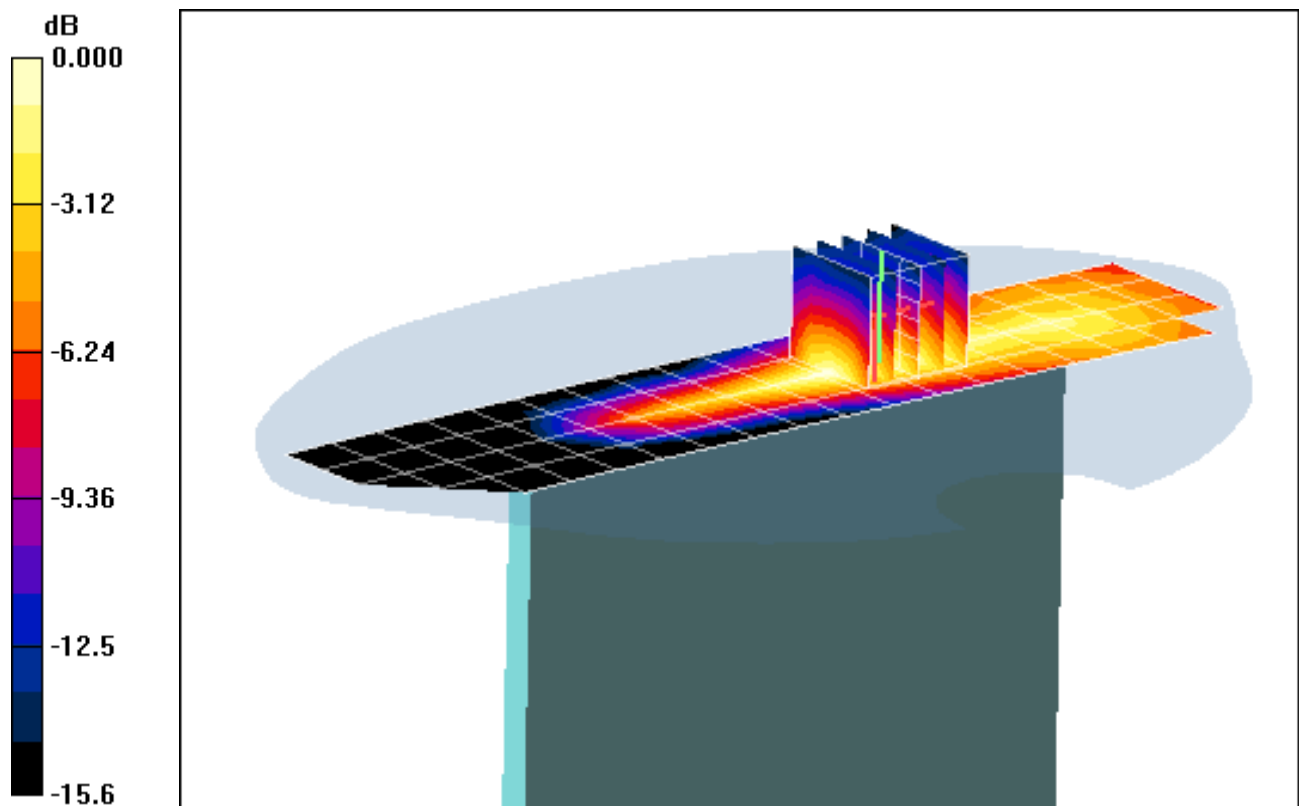

0 dB = 0.238mW/g

# PCTEST ENGINEERING LABORATORY, INC.

**DUT: A3LSCHI905; Type: Cellular/PCS CDMA/EVDO and LTE Tablet with Bluetooth and WLAN; Serial: FCC #3**

Communication System: IEEE 802.11b; Frequency: 2462 MHz; Duty Cycle: 1:1

Medium: 2450 Body Medium parameters used (interpolated):

$f = 2462 \text{ MHz}$ ;  $\sigma = 2.03 \text{ mho/m}$ ;  $\epsilon_r = 50.1$ ;  $\rho = 1000 \text{ kg/m}^3$

Phantom section: Flat Section; Space: 0.0 cm

Test Date: 05-03-2011; Ambient Temp: 24.3 °C; Tissue Temp: 22.9 °C

Probe: EX3DV4 - SN3550; ConvF(6.25, 6.25, 6.25); Calibrated: 2/14/2011

Sensor-Surface: 3mm (Mechanical Surface Detection)

Electronics: DAE4 Sn859; Calibrated: 7/8/2010

Phantom: SAM Sub; Type: SAM 4.0; Serial: TP-1357

Measurement SW: DASY4, V4.7 Build 80; Postprocessing SW: SEMCAD, V1.8 Build 186

**Mode: IEEE 802.11b, Body SAR, Ch.11, 1Mbps, Back Side**

**Area Scan (14x19x1):** Measurement grid: dx=15mm, dy=15mm

**Zoom Scan (5x5x7)/Cube 0:** Measurement grid: dx=8mm, dy=8mm, dz=5mm

Reference Value = 16.6 V/m

Peak SAR (extrapolated) = 1.62 W/kg

**SAR(1 g) = 0.686 mW/g; SAR(10 g) = 0.289 mW/g**

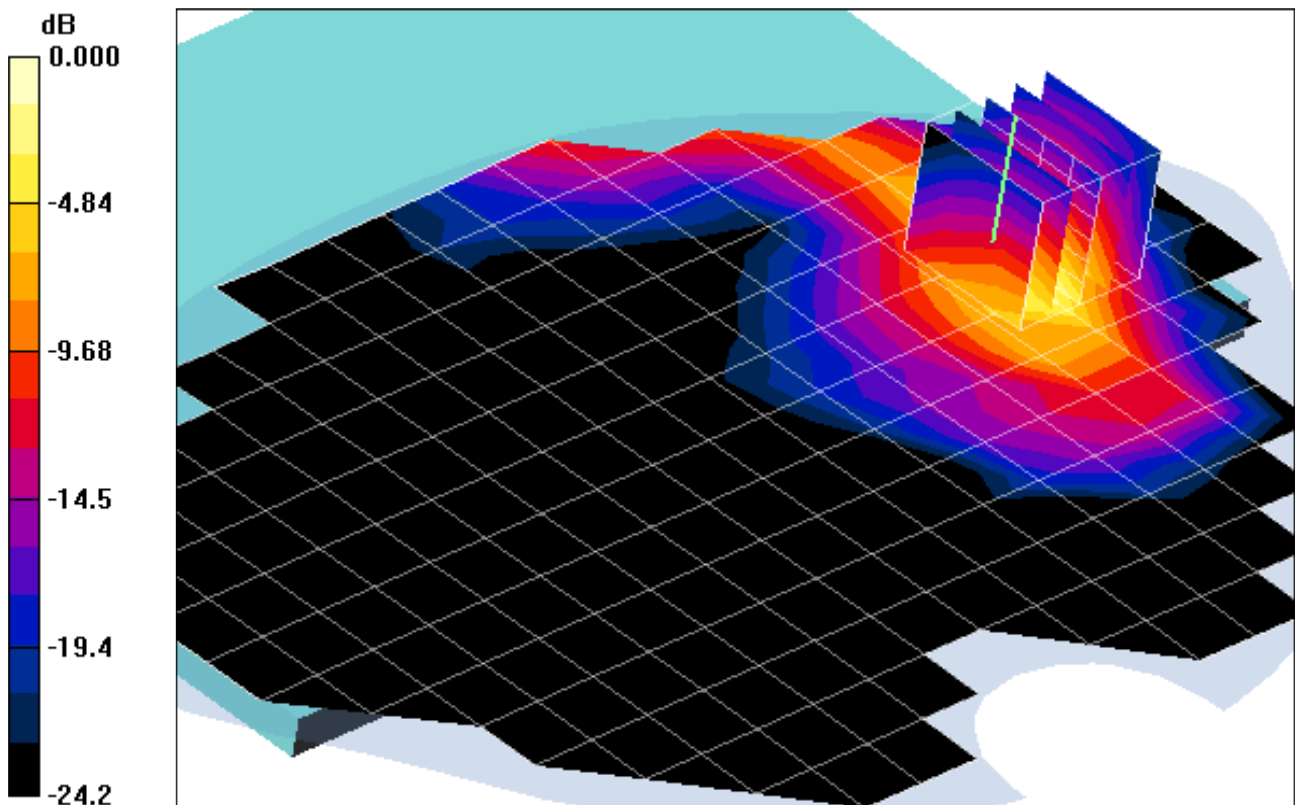

0 dB = 0.842mW/g

# PCTEST ENGINEERING LABORATORY, INC.

**DUT: A3LSCHI905; Type: Cellular/PCS CDMA/EVDO and LTE Tablet  
with Bluetooth and WLAN; Serial: FCC #3**

Communication System: IEEE 802.11b; Frequency: 2462 MHz; Duty Cycle: 1:1  
Medium: 2450 Body Medium parameters used (interpolated):  
 $f = 2462 \text{ MHz}$ ;  $\sigma = 2.03 \text{ mho/m}$ ;  $\epsilon_r = 50.1$ ;  $\rho = 1000 \text{ kg/m}^3$   
Phantom section: Flat Section; Space: 0.0 cm

Test Date: 05-03-2011; Ambient Temp: 24.3 °C; Tissue Temp: 22.9 °C

Probe: EX3DV4 - SN3550; ConvF(6.25, 6.25, 6.25); Calibrated: 2/14/2011  
Sensor-Surface: 3mm (Mechanical Surface Detection)  
Electronics: DAE4 Sn859; Calibrated: 7/8/2010  
Phantom: SAM Sub; Type: SAM 4.0; Serial: TP-1357

Measurement SW: DASY4, V4.7 Build 80; Postprocessing SW: SEMCAD, V1.8 Build 186

**Mode: IEEE 802.11b, Body SAR, Ch.11, 1Mbps, Bottom Edge**

**Area Scan (5x19x1):** Measurement grid: dx=15mm, dy=15mm

**Zoom Scan (5x5x7)/Cube 0:** Measurement grid: dx=8mm, dy=8mm, dz=5mm

Reference Value = 4.86 V/m

Peak SAR (extrapolated) = 0.081 W/kg

**SAR(1 g) = 0.045 mW/g; SAR(10 g) = 0.027 mW/g**

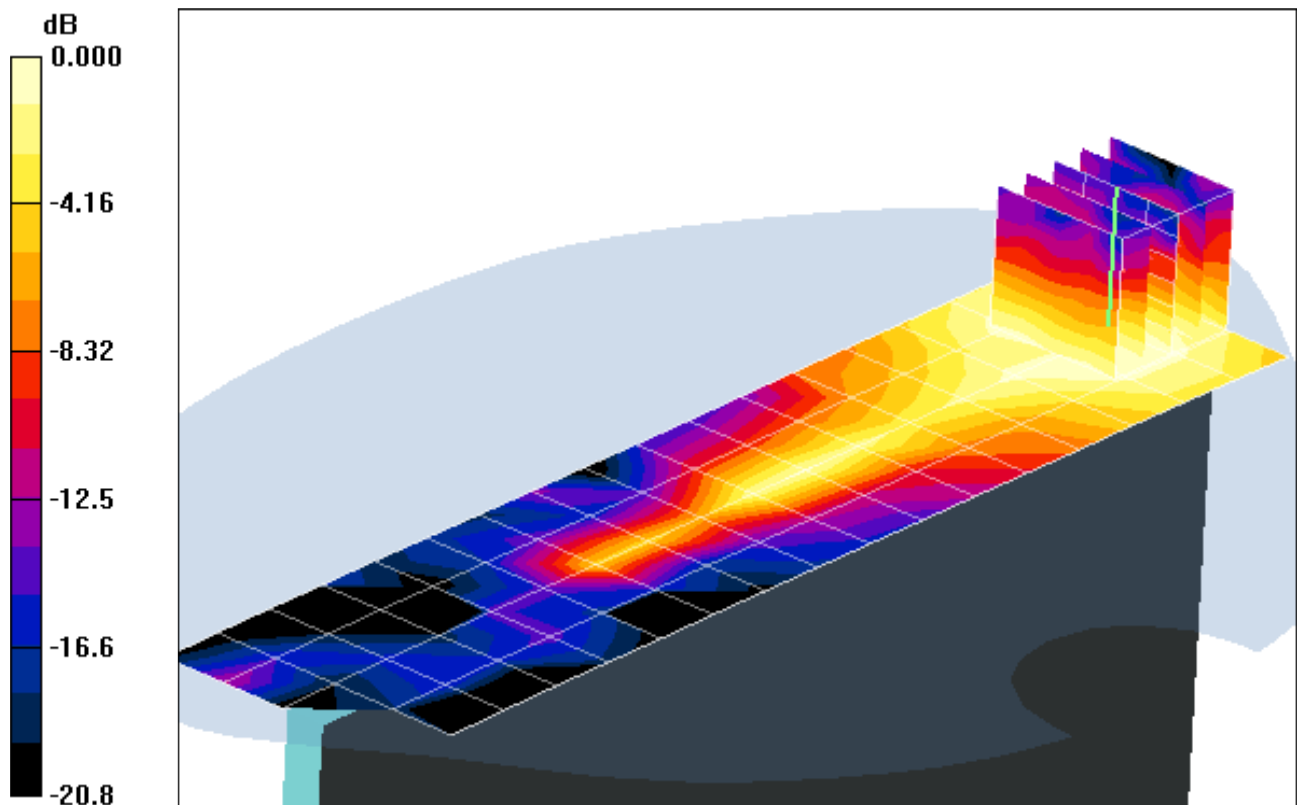

0 dB = 0.054mW/g

# PCTEST ENGINEERING LABORATORY, INC.

**DUT: A3LSCHI905; Type: Cellular/PCS CDMA/EVDO and LTE Tablet with Bluetooth and WLAN; Serial: FCC #3**

Communication System: IEEE 802.11b; Frequency: 2462 MHz; Duty Cycle: 1:1

Medium: 2450 Body Medium parameters used (interpolated):

$f = 2462 \text{ MHz}$ ;  $\sigma = 2.03 \text{ mho/m}$ ;  $\epsilon_r = 50.1$ ;  $\rho = 1000 \text{ kg/m}^3$

Phantom section: Flat Section; Space: 0.0 cm

Test Date: 05-03-2011; Ambient Temp: 24.3 °C; Tissue Temp: 22.9 °C

Probe: EX3DV4 - SN3550; ConvF(6.25, 6.25, 6.25); Calibrated: 2/14/2011

Sensor-Surface: 3mm (Mechanical Surface Detection)

Electronics: DAE4 Sn859; Calibrated: 7/8/2010

Phantom: SAM Sub; Type: SAM 4.0; Serial: TP-1357

Measurement SW: DASY4, V4.7 Build 80; Postprocessing SW: SEMCAD, V1.8 Build 186

**Mode: IEEE 802.11b, Body SAR, Ch.11, 1Mbps, Right Edge**

**Area Scan (5x15x1):** Measurement grid: dx=15mm, dy=15mm

**Zoom Scan (5x5x7)/Cube 0:** Measurement grid: dx=8mm, dy=8mm, dz=5mm

Reference Value = 25.2 V/m

Peak SAR (extrapolated) = 2.67 W/kg

**SAR(1 g) = 1.18 mW/g; SAR(10 g) = 0.477 mW/g**

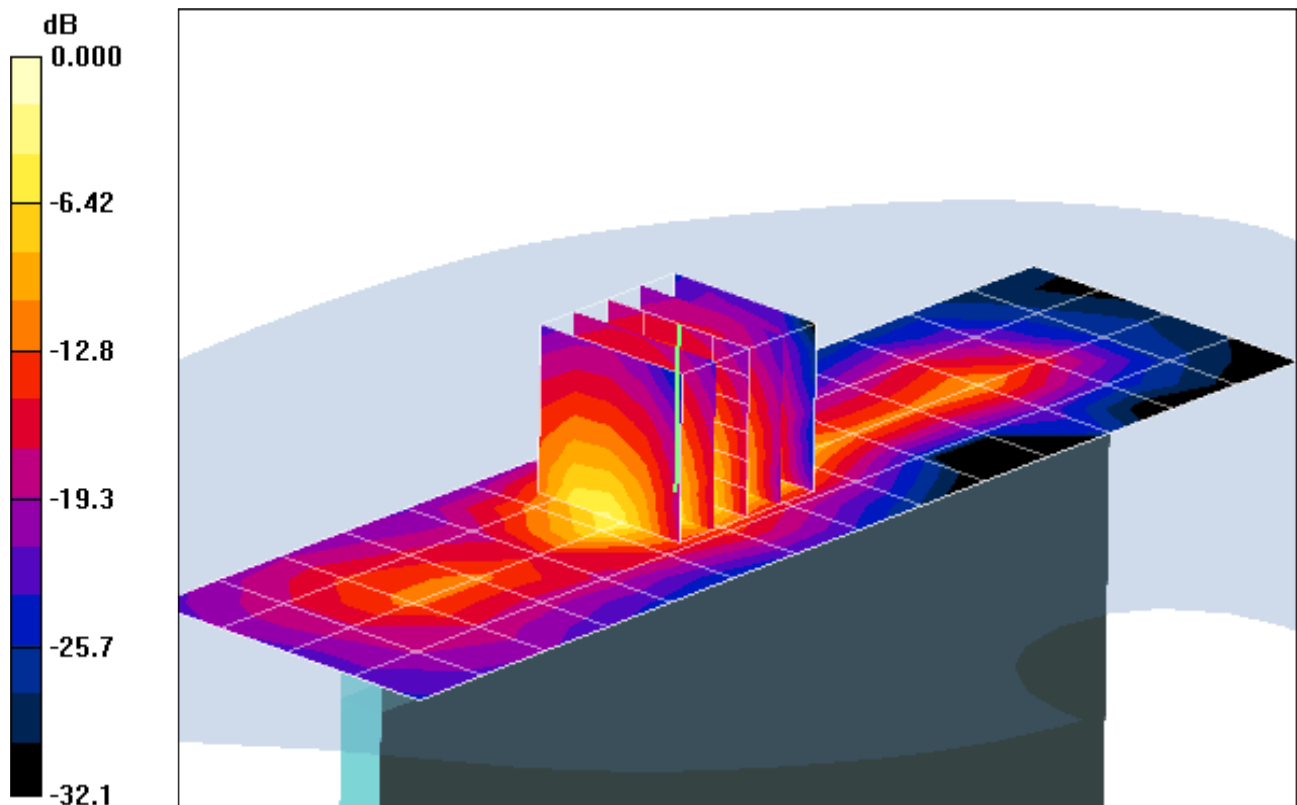

0 dB = 1.48mW/g

# PCTEST ENGINEERING LABORATORY, INC.

**DUT: A3LSCHI905; Type: Cellular/PCS CDMA/EVDO and LTE Tablet  
with Bluetooth and WLAN; Serial: FCC #3**

Communication System: IEEE 802.11b; Frequency: 2462 MHz; Duty Cycle: 1:1

Medium: 2450 Body Medium parameters used (interpolated):

$f = 2462 \text{ MHz}$ ;  $\sigma = 2.03 \text{ mho/m}$ ;  $\epsilon_r = 50.1$ ;  $\rho = 1000 \text{ kg/m}^3$

Phantom section: Flat Section; Space: 0.0 cm

Test Date: 05-03-2011; Ambient Temp: 24.3 °C; Tissue Temp: 22.9 °C

Probe: EX3DV4 - SN3550; ConvF(6.25, 6.25, 6.25); Calibrated: 2/14/2011

Sensor-Surface: 3mm (Mechanical Surface Detection)

Electronics: DAE4 Sn859; Calibrated: 7/8/2010

Phantom: SAM Sub; Type: SAM 4.0; Serial: TP-1357

Measurement SW: DASY4, V4.7 Build 80; Postprocessing SW: SEMCAD, V1.8 Build 186

**Mode: IEEE 802.11b, Body SAR, Ch.11, 1Mbps, Right Edge**

**Area Scan (5x15x1):** Measurement grid: dx=15mm, dy=15mm

**Zoom Scan (5x5x7)/Cube 0:** Measurement grid: dx=8mm, dy=8mm, dz=5mm

Reference Value = 25.2 V/m

Peak SAR (extrapolated) = 2.67 W/kg

**SAR(1 g) = 1.18 mW/g; SAR(10 g) = 0.477 mW/g**

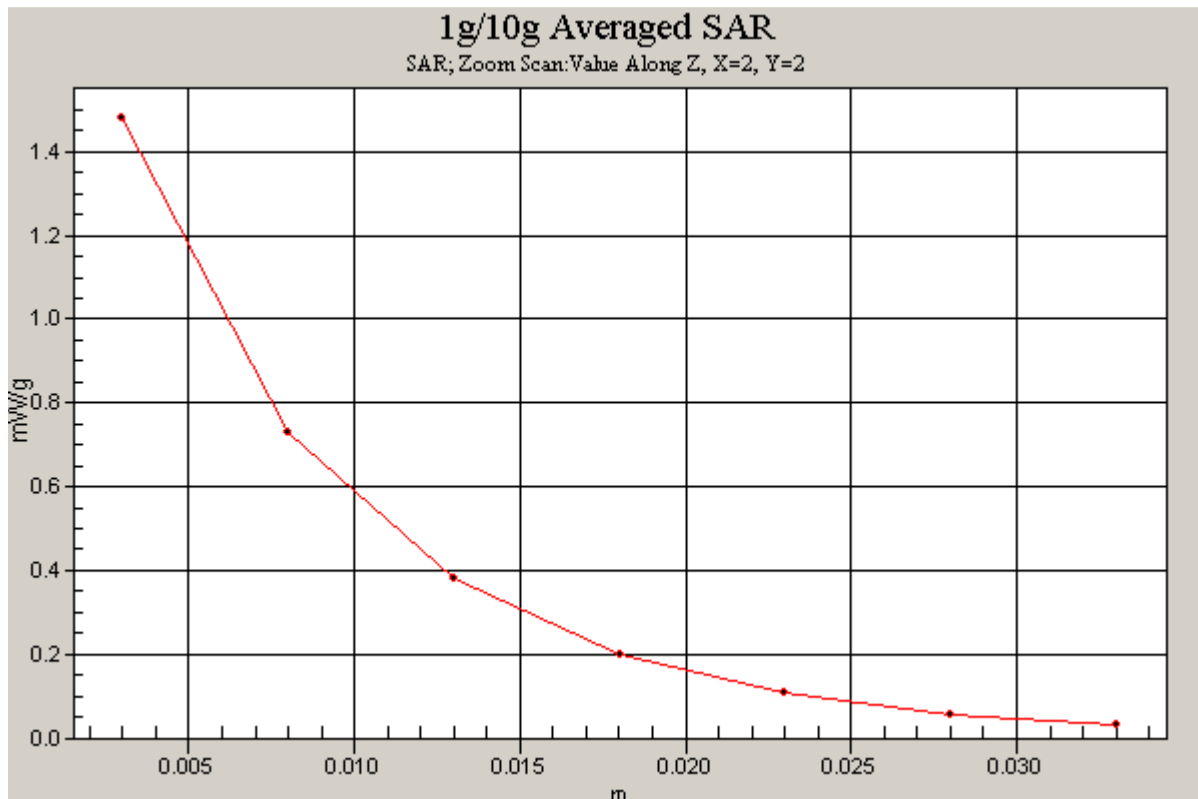

# PCTEST ENGINEERING LABORATORY, INC.

**DUT: A3LSCHI905; Type: Cellular/PCS CDMA/EVDO and LTE Tablet  
with Bluetooth and WLAN; Serial: 12**

Communication System: IEEE 802.11a 5.2-5.8 GHz Band; Frequency: 5180 MHz; Duty Cycle: 1:1  
Medium: 5 GHz Body Medium parameters used (interpolated):  
 $f = 5180 \text{ MHz}$ ;  $\sigma = 5.26 \text{ mho/m}$ ;  $\epsilon_r = 49.1$ ;  $\rho = 1000 \text{ kg/m}^3$   
Phantom section: Flat Section; Space: 0.0 cm

Test Date: 05-03-2011; Ambient Temp: 23.6 °C; Tissue Temp: 22.3 °C

Probe: EX3DV4 - SN3550; ConvF(3.58, 3.58, 3.58); Calibrated: 2/14/2011  
Sensor-Surface: 2mm (Mechanical Surface Detection)  
Electronics: DAE4 Sn859; Calibrated: 7/8/2010  
Phantom: SAM Main; Type: SAM 4.0; Serial: TP-1114

Measurement SW: DASY4, V4.7 Build 80; Postprocessing SW: SEMCAD, V1.8 Build 186

**Mode: IEEE 802.11a, 5.2 GHz, Body SAR, Ch 36, 6 Mbps, Back Side**

**Area Scan (9x26x1):** Measurement grid: dx=10mm, dy=10mm

**Zoom Scan (7x7x11)/Cube 0:** Measurement grid: dx=4mm, dy=4mm, dz=2mm

Reference Value = 6.93 V/m

Peak SAR (extrapolated) = 0.542 W/kg

**SAR(1 g) = 0.139 mW/g; SAR(10 g) = 0.041 mW/g**

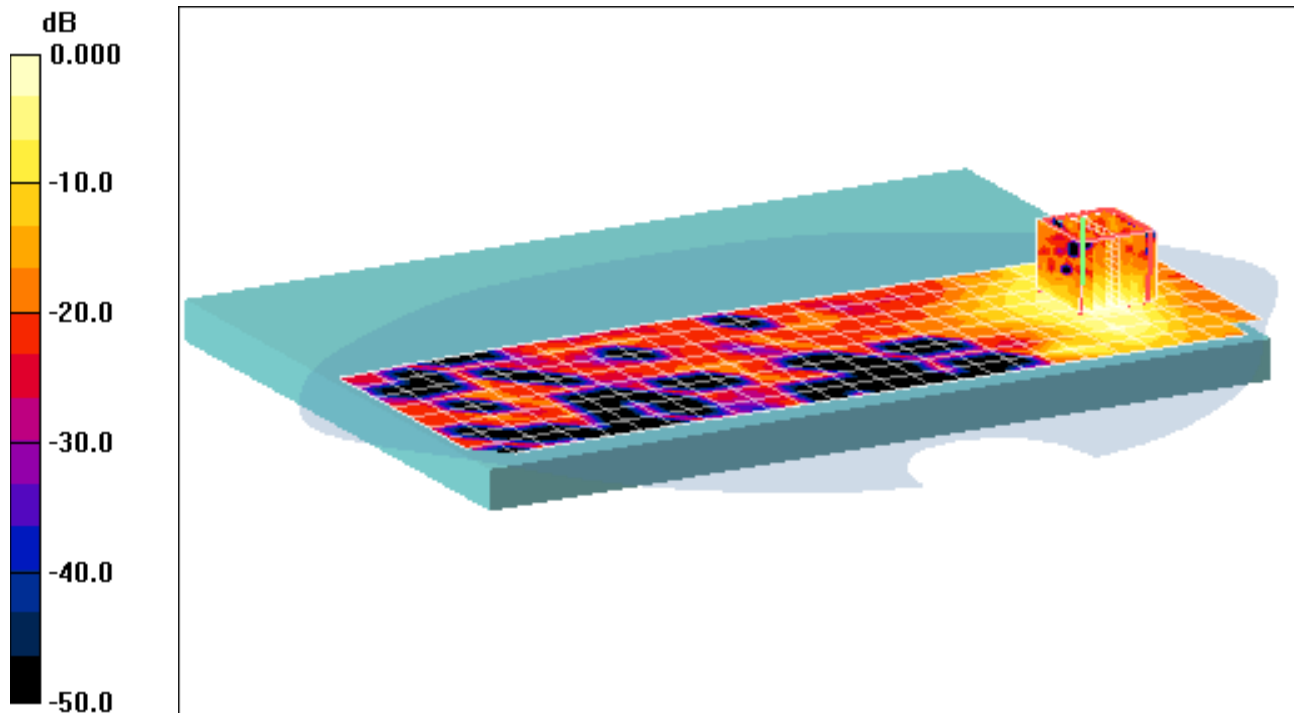

0 dB = 0.297mW/g

# PCTEST ENGINEERING LABORATORY, INC.

**DUT: A3LSCHI905; Type: Cellular/PCS CDMA/EVDO and LTE Tablet  
with Bluetooth and WLAN; Serial: FCC #3**

Communication System: IEEE 802.11a 5.2-5.8 GHz Band; Frequency: 5180 MHz; Duty Cycle: 1:1  
Medium: 5 GHz Body Medium parameters used (interpolated):  
 $f = 5180 \text{ MHz}$ ;  $\sigma = 5.26 \text{ mho/m}$ ;  $\epsilon_r = 49.1$ ;  $\rho = 1000 \text{ kg/m}^3$   
Phantom section: Flat Section; Space: 0.0 cm

Test Date: 05-03-2011; Ambient Temp: 23.6 °C; Tissue Temp: 22.3 °C

Probe: EX3DV4 - SN3550; ConvF(3.58, 3.58, 3.58); Calibrated: 2/14/2011

Sensor-Surface: 2mm (Mechanical Surface Detection)

Electronics: DAE4 Sn859; Calibrated: 7/8/2010

Phantom: SAM Main; Type: SAM 4.0; Serial: TP-1114

Measurement SW: DASY4, V4.7 Build 80; Postprocessing SW: SEMCAD, V1.8 Build 186

**Mode: IEEE 802.11a, 5.2 GHz, Body SAR, Ch 36, 6 Mbps, Bottom Side**

**Area Scan (7x28x1):** Measurement grid: dx=10mm, dy=10mm

**Zoom Scan (7x7x11)/Cube 0:** Measurement grid: dx=4mm, dy=4mm, dz=2mm

Reference Value = 3.02 V/m

Peak SAR (extrapolated) = 0.166 W/kg

**SAR(1 g) = 0.029 mW/g; SAR(10 g) = 0.00847 mW/g**

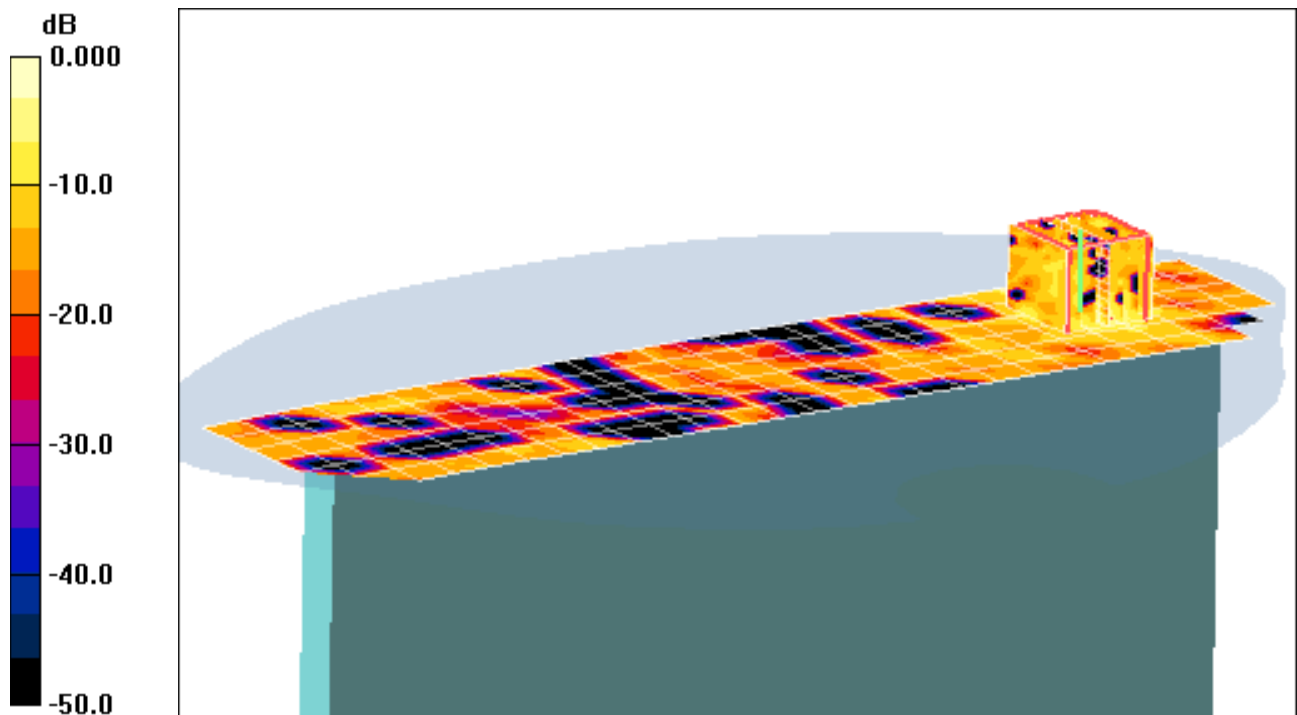

0 dB = 0.077mW/g

# PCTEST ENGINEERING LABORATORY, INC.

**DUT: A3LSCHI905; Type: Cellular/PCS CDMA/EVDO and LTE Tablet  
with Bluetooth and WLAN; Serial: FCC #3**

Communication System: IEEE 802.11a 5.2-5.8 GHz Band; Frequency: 5180 MHz; Duty Cycle: 1:1  
Medium: 5 GHz Body Medium parameters used (interpolated):  
 $f = 5180 \text{ MHz}$ ;  $\sigma = 5.26 \text{ mho/m}$ ;  $\epsilon_r = 49.1$ ;  $\rho = 1000 \text{ kg/m}^3$   
Phantom section: Flat Section; Space: 0.0 cm

Test Date: 05-03-2011; Ambient Temp: 23.6 °C; Tissue Temp: 22.3 °C

Probe: EX3DV4 - SN3550; ConvF(3.58, 3.58, 3.58); Calibrated: 2/14/2011  
Sensor-Surface: 2mm (Mechanical Surface Detection)  
Electronics: DAE4 Sn859; Calibrated: 7/8/2010  
Phantom: SAM Main; Type: SAM 4.0; Serial: TP-1114

Measurement SW: DASY4, V4.7 Build 80; Postprocessing SW: SEMCAD, V1.8 Build 186

**Mode: IEEE 802.11a, 5.2 GHz, Body SAR, Ch 36, 6 Mbps, Right Side**

**Area Scan (7x22x1):** Measurement grid: dx=10mm, dy=10mm

**Zoom Scan (7x7x11)/Cube 0:** Measurement grid: dx=4mm, dy=4mm, dz=2mm

Reference Value = 7.26 V/m

Peak SAR (extrapolated) = 1.28 W/kg

**SAR(1 g) = 0.259 mW/g; SAR(10 g) = 0.084 mW/g**

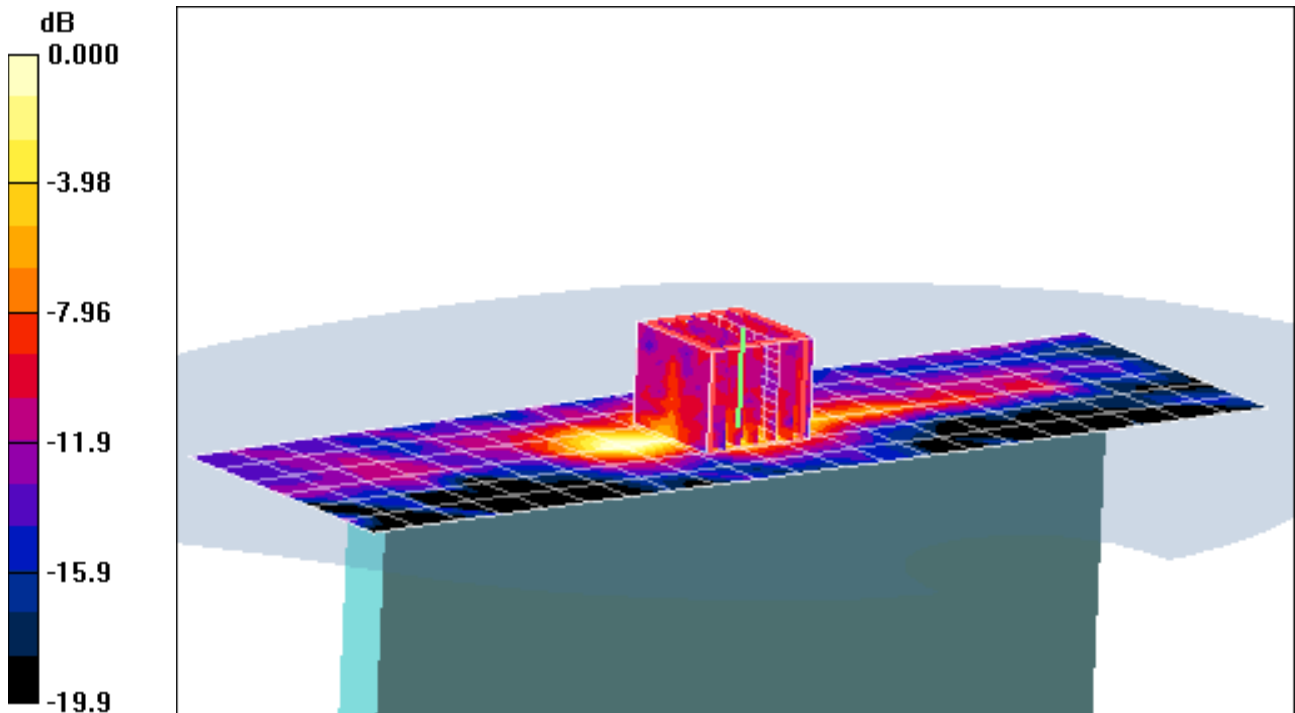

0 dB = 0.498mW/g

# PCTEST ENGINEERING LABORATORY, INC.

**DUT: A3LSCHI905; Type: Cellular/PCS CDMA/EVDO and LTE Tablet  
with Bluetooth and WLAN; Serial: FCC #3**

Communication System: IEEE 802.11a 5.2-5.8 GHz Band; Frequency: 5280 MHz; Duty Cycle: 1:1  
Medium: 5 GHz Body Medium parameters used (interpolated):  
 $f = 5280 \text{ MHz}$ ;  $\sigma = 5.41 \text{ mho/m}$ ;  $\epsilon_r = 48.9$ ;  $\rho = 1000 \text{ kg/m}^3$   
Phantom section: Flat Section; Space: 0.0 cm

Test Date: 05-03-2011; Ambient Temp: 23.6 °C; Tissue Temp: 22.3 °C

Probe: EX3DV4 - SN3550; ConvF(3.31, 3.31, 3.31); Calibrated: 2/14/2011  
Sensor-Surface: 2mm (Mechanical Surface Detection)  
Electronics: DAE4 Sn859; Calibrated: 7/8/2010  
Phantom: SAM Main; Type: SAM 4.0; Serial: TP-1114

Measurement SW: DASY4, V4.7 Build 80; Postprocessing SW: SEMCAD, V1.8 Build 186

**Mode: IEEE 802.11a, 5.3 GHz, Body SAR, Ch 56, 6 Mbps, Back Side**

**Area Scan (9x26x1):** Measurement grid: dx=10mm, dy=10mm

**Zoom Scan (7x7x11)/Cube 0:** Measurement grid: dx=4mm, dy=4mm, dz=2mm

Reference Value = 7.47 V/m

Peak SAR (extrapolated) = 0.985 W/kg

**SAR(1 g) = 0.294 mW/g; SAR(10 g) = 0.182 mW/g**

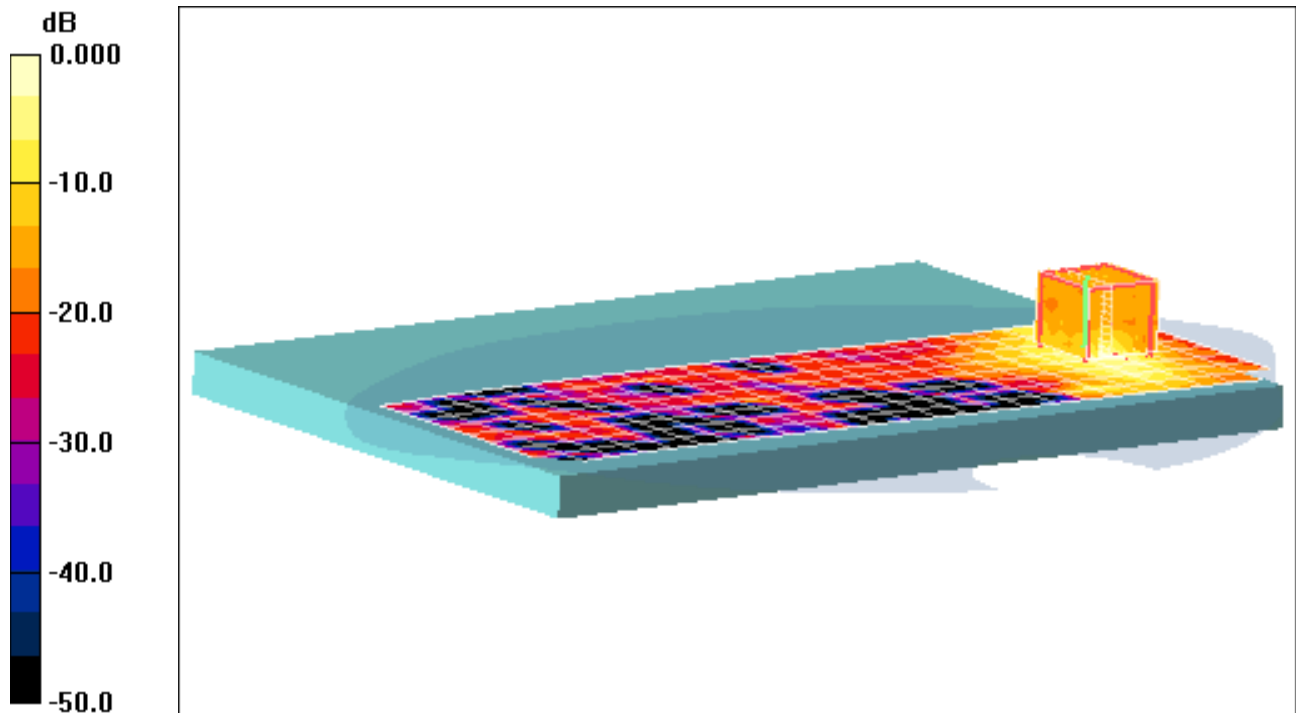

0 dB = 0.419mW/g

# PCTEST ENGINEERING LABORATORY, INC.

**DUT: A3LSCHI905; Type: Cellular/PCS CDMA/EVDO and LTE Tablet  
with Bluetooth and WLAN; Serial: FCC #3**

Communication System: IEEE 802.11a 5.2-5.8 GHz Band; Frequency: 5280 MHz; Duty Cycle: 1:1  
Medium: 5 GHz Body Medium parameters used (interpolated):  
 $f = 5280 \text{ MHz}$ ;  $\sigma = 5.41 \text{ mho/m}$ ;  $\epsilon_r = 48.9$ ;  $\rho = 1000 \text{ kg/m}^3$   
Phantom section: Flat Section; Space: 0.0 cm

Test Date: 05-03-2011; Ambient Temp: 23.6 °C; Tissue Temp: 22.3 °C

Probe: EX3DV4 - SN3550; ConvF(3.31, 3.31, 3.31); Calibrated: 2/14/2011  
Sensor-Surface: 2mm (Mechanical Surface Detection)  
Electronics: DAE4 Sn859; Calibrated: 7/8/2010  
Phantom: SAM Main; Type: SAM 4.0; Serial: TP-1114

Measurement SW: DASY4, V4.7 Build 80; Postprocessing SW: SEMCAD, V1.8 Build 186

**Mode: IEEE 802.11a, 5.3 GHz, Body SAR, Ch 56, 6 Mbps, Bottom Side**

**Area Scan (7x28x1):** Measurement grid:  $dx=10\text{mm}$ ,  $dy=10\text{mm}$

**Zoom Scan (7x7x11)/Cube 0:** Measurement grid:  $dx=4\text{mm}$ ,  $dy=4\text{mm}$ ,  $dz=2\text{mm}$

Reference Value = 3.40 V/m

Peak SAR (extrapolated) = 0.235 W/kg

**SAR(1 g) = 0.048 mW/g; SAR(10 g) = 0.014 mW/g**

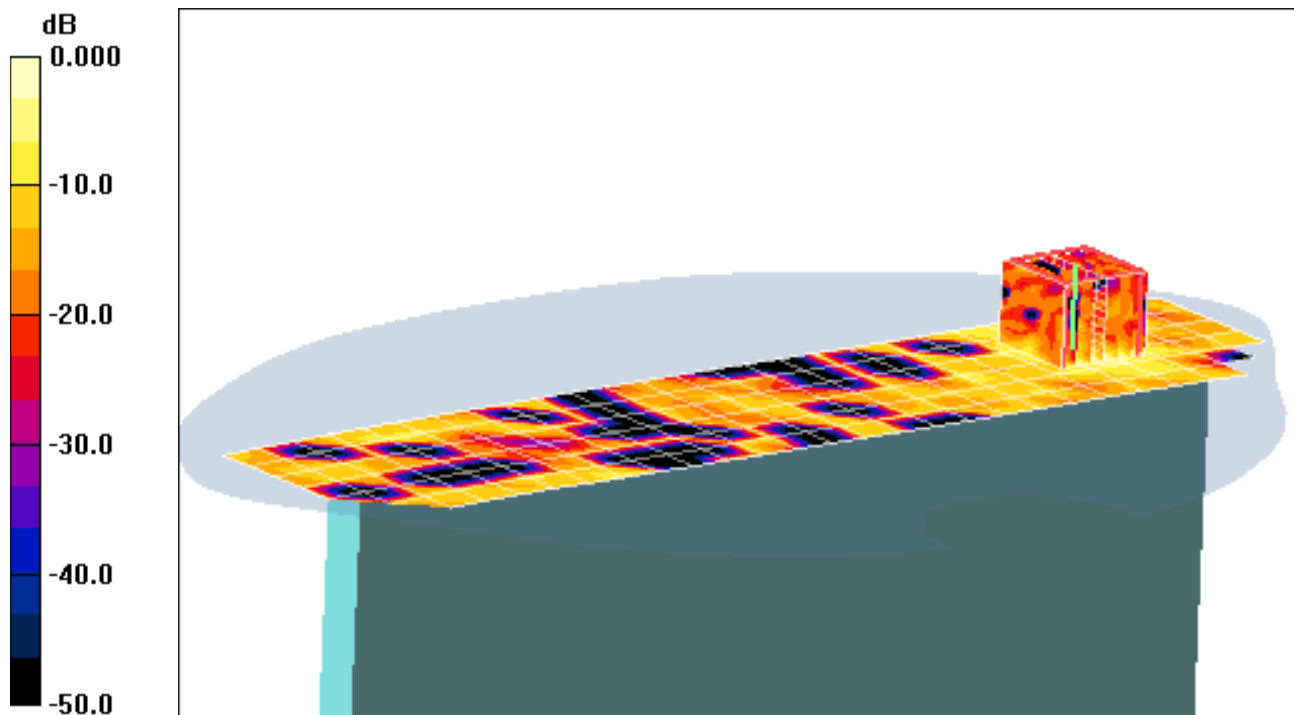

0 dB = 0.046mW/g

# PCTEST ENGINEERING LABORATORY, INC.

**DUT: A3LSCHI905; Type: Cellular/PCS CDMA/EVDO and LTE Tablet  
with Bluetooth and WLAN; Serial: FCC #3**

Communication System: IEEE 802.11a 5.2-5.8 GHz Band; Frequency: 5280 MHz; Duty Cycle: 1:1

Medium: 5 GHz Body Medium parameters used (interpolated):

$f = 5280 \text{ MHz}$ ;  $\sigma = 5.41 \text{ mho/m}$ ;  $\epsilon_r = 48.9$ ;  $\rho = 1000 \text{ kg/m}^3$

Phantom section: Flat Section; Space: 0.0 cm

Test Date: 05-03-2011; Ambient Temp: 23.6 °C; Tissue Temp: 22.3 °C

Probe: EX3DV4 - SN3550; ConvF(3.31, 3.31, 3.31); Calibrated: 2/14/2011

Sensor-Surface: 2mm (Mechanical Surface Detection)

Electronics: DAE4 Sn859; Calibrated: 7/8/2010

Phantom: SAM Main; Type: SAM 4.0; Serial: TP-1114

Measurement SW: DASY4, V4.7 Build 80; Postprocessing SW: SEMCAD, V1.8 Build 186

**Mode: IEEE 802.11a, 5.3 GHz, Body SAR, Ch 56, 6 Mbps, Right Side**

**Area Scan (7x22x1):** Measurement grid: dx=10mm, dy=10mm

**Zoom Scan (7x7x11)/Cube 0:** Measurement grid: dx=4mm, dy=4mm, dz=2mm

Reference Value = 7.57 V/m

Peak SAR (extrapolated) = 0.977 W/kg

**SAR(1 g) = 0.284 mW/g; SAR(10 g) = 0.092 mW/g**

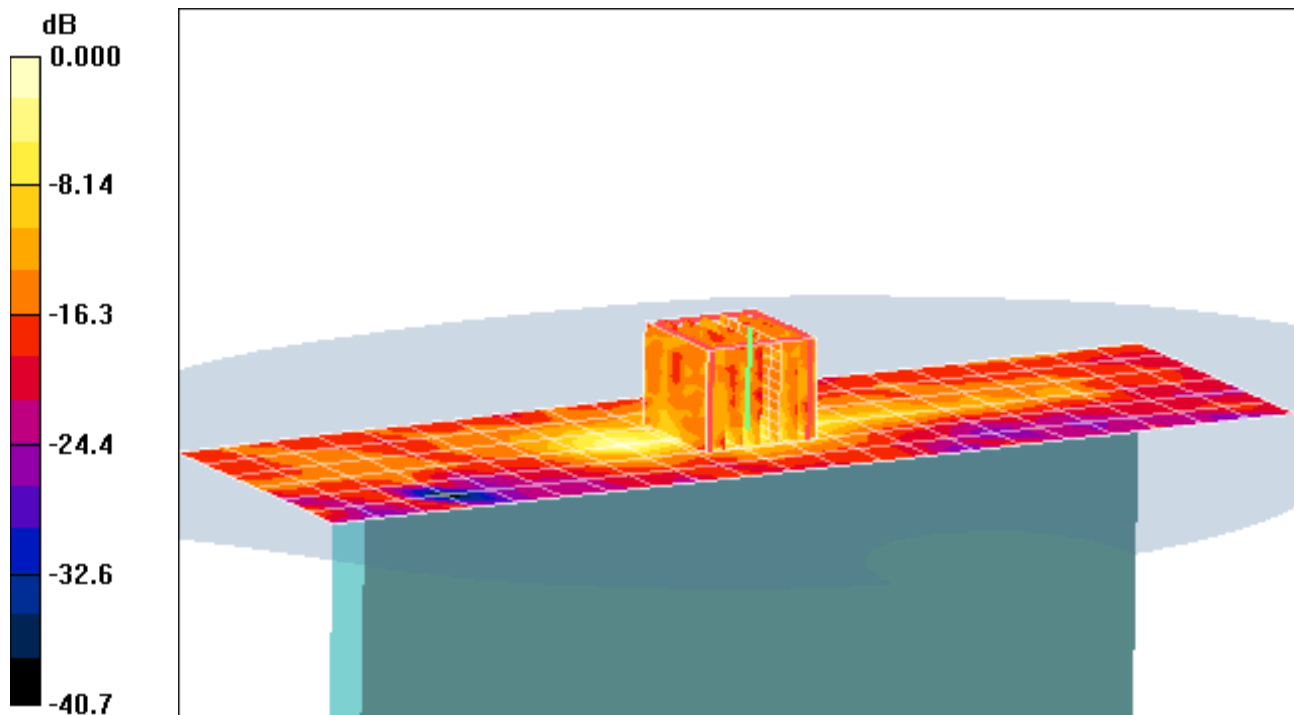

0 dB = 0.982mW/g

# PCTEST ENGINEERING LABORATORY, INC.

**DUT: A3LSCHI905; Type: Cellular/PCS CDMA/EVDO and LTE Tablet  
with Bluetooth and WLAN; Serial: FCC #3**

Communication System: IEEE 802.11a 5.2-5.8 GHz Band; Frequency: 5700 MHz; Duty Cycle: 1:1  
Medium: 5 GHz Body Medium parameters used (interpolated):  
 $f = 5700 \text{ MHz}$ ;  $\sigma = 6.04 \text{ mho/m}$ ;  $\epsilon_r = 48$ ;  $\rho = 1000 \text{ kg/m}^3$   
Phantom section: Flat Section; Space: 0.0 cm

Test Date: 05-03-2011; Ambient Temp: 23.8 °C; Tissue Temp: 22.5 °C

Probe: EX3DV4 - SN3550; ConvF(3.19, 3.19, 3.19); Calibrated: 2/14/2011  
Sensor-Surface: 2mm (Mechanical Surface Detection)  
Electronics: DAE4 Sn859; Calibrated: 7/8/2010  
Phantom: SAM Main; Type: SAM 4.0; Serial: TP-1114

Measurement SW: DASY4, V4.7 Build 80; Postprocessing SW: SEMCAD, V1.8 Build 186

**Mode: IEEE 802.11a, 5.5 GHz, Body SAR, Ch 140, 6 Mbps, Back Side**

**Area Scan (9x26x1):** Measurement grid: dx=10mm, dy=10mm

**Zoom Scan (7x7x11)/Cube 0:** Measurement grid: dx=4mm, dy=4mm, dz=2mm

Reference Value = 8.05 V/m

Peak SAR (extrapolated) = 2.69 W/kg

**SAR(1 g) = 0.534 mW/g; SAR(10 g) = 0.155 mW/g**

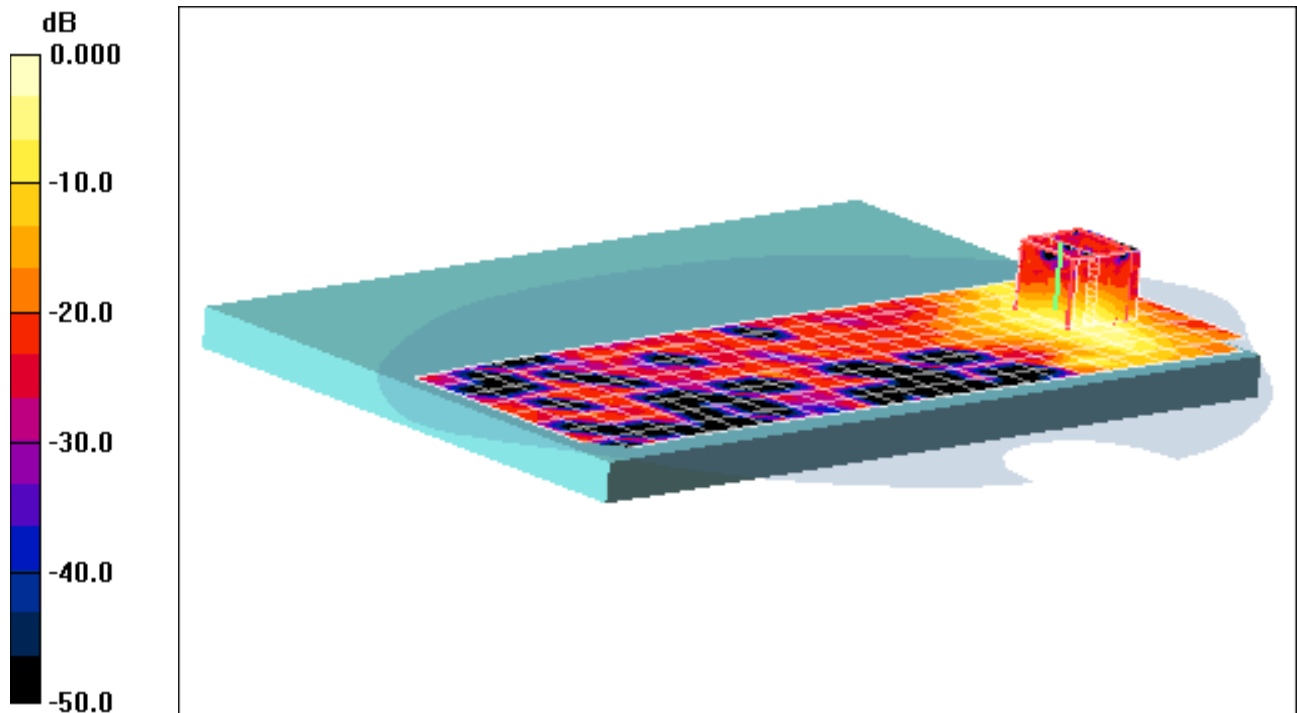

0 dB = 0.419mW/g

# PCTEST ENGINEERING LABORATORY, INC.

**DUT: A3LSCHI905; Type: Cellular/PCS CDMA/EVDO and LTE Tablet  
with Bluetooth and WLAN; Serial: FCC #3**

Communication System: IEEE 802.11a 5.2-5.8 GHz Band; Frequency: 5700 MHz; Duty Cycle 1:1  
Medium: 5 GHz Body Medium parameters used (interpolated):

$f = 5700 \text{ MHz}$ ;  $\sigma = 6.04 \text{ mho/m}$ ;  $\epsilon_r = 48$ ;  $\rho = 1000 \text{ kg/m}^3$

Phantom section: Flat Section; Space: 0.0 cm

Test Date: 05-03-2011; Ambient Temp: 23.8 °C; Tissue Temp: 22.5 °C

Probe: EX3DV4 - SN3550; ConvF(3.19, 3.19, 3.19); Calibrated: 2/14/2011

Sensor-Surface: 2mm (Mechanical Surface Detection)

Electronics: DAE4 Sn859; Calibrated: 7/8/2010

Phantom: SAM Main; Type: SAM 4.0; Serial: TP-1114

Measurement SW: DASY4, V4.7 Build 80; Postprocessing SW: SEMCAD, V1.8 Build 186

**Mode: IEEE 802.11a, 5.5 GHz, Body SAR, Ch 140, 6 Mbps, Bottom Side**

**Area Scan (7x28x1):** Measurement grid: dx=10mm, dy=10mm

**Zoom Scan (7x7x11)/Cube 0:** Measurement grid: dx=4mm, dy=4mm, dz=2mm

Reference Value = 2.78 V/m

Peak SAR (extrapolated) = 0.324 W/kg

**SAR(1 g) = 0.048 mW/g; SAR(10 g) = 0.017 mW/g**

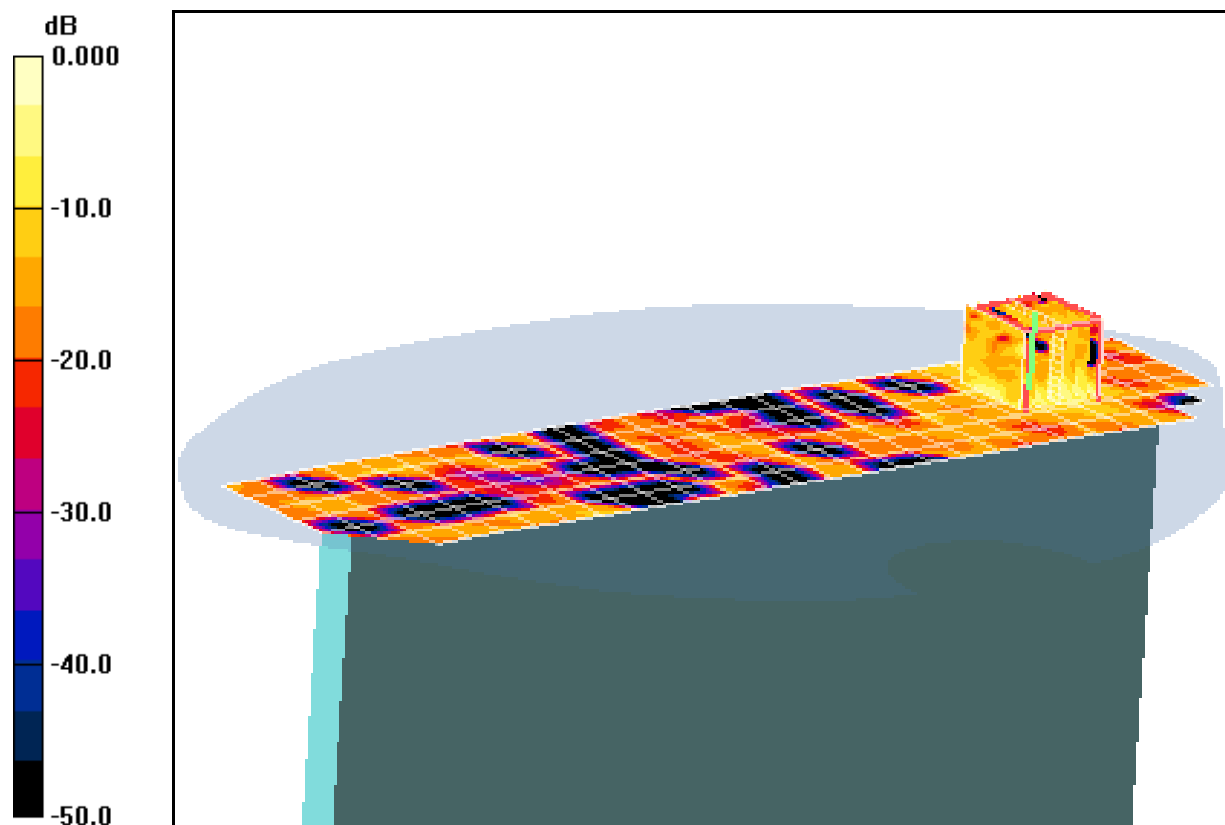

0 dB = 0.113mW/g

# PCTEST ENGINEERING LABORATORY, INC.

**DUT: A3LSCHI905; Type: Cellular/PCS CDMA/EVDO and LTE Tablet  
with Bluetooth and WLAN; Serial: FCC #3**

Communication System: IEEE 802.11a 5.2-5.8 GHz Band; Frequency: 5700 MHz; Duty Cycle: 1:1  
Medium: 5 GHz Body Medium parameters used (interpolated):  
 $f = 5700 \text{ MHz}$ ;  $\sigma = 6.04 \text{ mho/m}$ ;  $\epsilon_r = 48$ ;  $\rho = 1000 \text{ kg/m}^3$   
Phantom section: Flat Section; Space: 0.0 cm

Test Date: 05-03-2011; Ambient Temp: 23.8 °C; Tissue Temp: 22.5 °C

Probe: EX3DV4 - SN3550; ConvF(3.19, 3.19, 3.19); Calibrated: 2/14/2011

Sensor-Surface: 2mm (Mechanical Surface Detection)

Electronics: DAE4 Sn859; Calibrated: 7/8/2010

Phantom: SAM Main; Type: SAM 4.0; Serial: TP-1114

Measurement SW: DASY4, V4.7 Build 80; Postprocessing SW: SEMCAD, V1.8 Build 186

**Mode: IEEE 802.11a, 5.5 GHz, Body SAR, Ch 140, 6 Mbps, Right Side**

**Area Scan (7x22x1):** Measurement grid: dx=10mm, dy=10mm

**Zoom Scan (7x7x11)/Cube 0:** Measurement grid: dx=4mm, dy=4mm, dz=2mm

Reference Value = 10.7 V/m

Peak SAR (extrapolated) = 2.70 W/kg

**SAR(1 g) = 0.654 mW/g; SAR(10 g) = 0.212 mW/g**

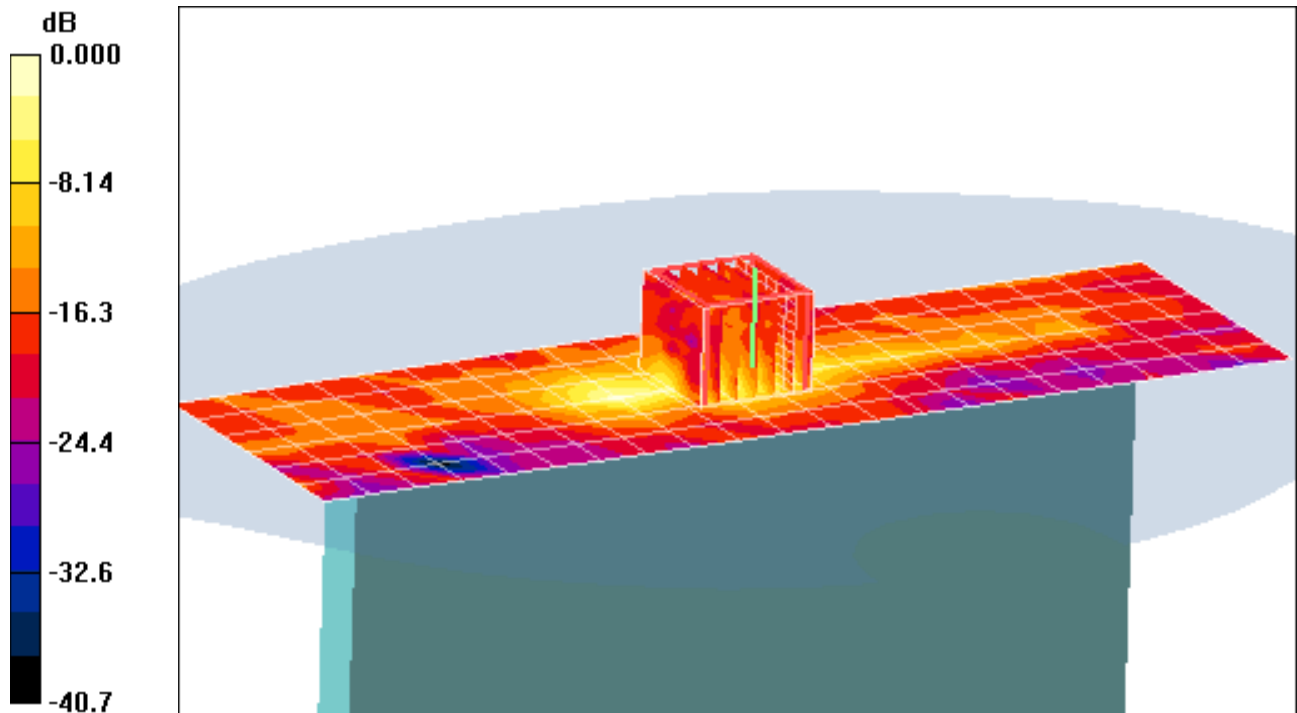

0 dB = 0.982mW/g

# PCTEST ENGINEERING LABORATORY, INC.

**DUT: A3LSCHI905; Type: Cellular/PCS CDMA/EVDO and LTE Tablet  
with Bluetooth and WLAN; Serial: FCC #3**

Communication System: IEEE 802.11a 5.2-5.8 GHz Band; Frequency: 5825 MHz; Duty Cycle: 1:1  
Medium: 5 GHz Body Medium parameters used (interpolated):  
 $f = 5825 \text{ MHz}$ ;  $\sigma = 6.21 \text{ mho/m}$ ;  $\epsilon_r = 47.6$ ;  $\rho = 1000 \text{ kg/m}^3$   
Phantom section: Flat Section; Space: 0.0 cm

Test Date: 05-03-2011; Ambient Temp: 24.0 °C; Tissue Temp: 22.7 °C

Probe: EX3DV4 - SN3550; ConvF(3.29, 3.29, 3.29); Calibrated: 2/14/2011  
Sensor-Surface: 2mm (Mechanical Surface Detection)  
Electronics: DAE4 Sn859; Calibrated: 7/8/2010  
Phantom: SAM Main; Type: SAM 4.0; Serial: TP-1114

Measurement SW: DASY4, V4.7 Build 80; Postprocessing SW: SEMCAD, V1.8 Build 186

**Mode: IEEE 802.11a, 5.8 GHz, Body SAR, Ch 165, 6 Mbps, Back Side**

**Area Scan (9x26x1):** Measurement grid: dx=10mm, dy=10mm

**Zoom Scan (7x7x11)/Cube 0:** Measurement grid: dx=4mm, dy=4mm, dz=2mm

Reference Value = 7.09 V/m

Peak SAR (extrapolated) = 2.17 W/kg

**SAR(1 g) = 0.464 mW/g; SAR(10 g) = 0.132 mW/g**

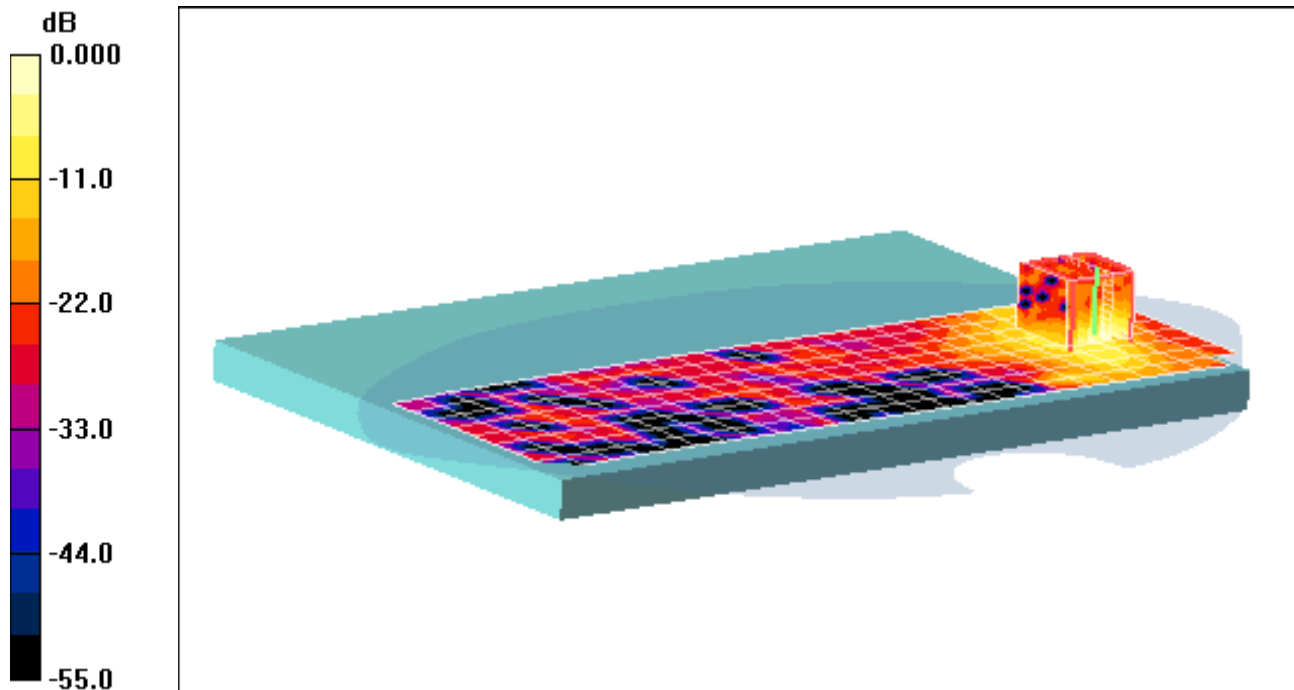

0 dB = 0.995mW/g

# PCTEST ENGINEERING LABORATORY, INC.

**DUT: A3LSCHI905; Type: Cellular/PCS CDMA/EVDO and LTE Tablet  
with Bluetooth and WLAN; Serial: FCC #3**

Communication System: IEEE 802.11a 5.2-5.8 GHz Band; Frequency: 5825 MHz; Duty Cycle: 1:1  
Medium: 5 GHz Body Medium parameters used (interpolated):  
 $f = 5825 \text{ MHz}$ ;  $\sigma = 6.21 \text{ mho/m}$ ;  $\epsilon_r = 47.6$ ;  $\rho = 1000 \text{ kg/m}^3$   
Phantom section: Flat Section; Space: 0.0 cm

Test Date: 05-03-2011; Ambient Temp: 24.0 °C; Tissue Temp: 22.7 °C

Probe: EX3DV4 - SN3550; ConvF(3.29, 3.29, 3.29); Calibrated: 2/14/2011

Sensor-Surface: 2mm (Mechanical Surface Detection)

Electronics: DAE4 Sn859; Calibrated: 7/8/2010

Phantom: SAM Main; Type: SAM 4.0; Serial: TP-1114

Measurement SW: DASY4, V4.7 Build 80; Postprocessing SW: SEMCAD, V1.8 Build 186

**Mode: IEEE 802.11a, 5.8 GHz, Body SAR, Ch 165, 6 Mbps, Bottom Side**

**Area Scan (7x28x1):** Measurement grid: dx=10mm, dy=10mm

**Zoom Scan (7x7x11)/Cube 0:** Measurement grid: dx=4mm, dy=4mm, dz=2mm

Reference Value = 3.17 V/m

Peak SAR (extrapolated) = 0.362 W/kg

**SAR(1 g) = 0.086 mW/g; SAR(10 g) = 0.053 mW/g**

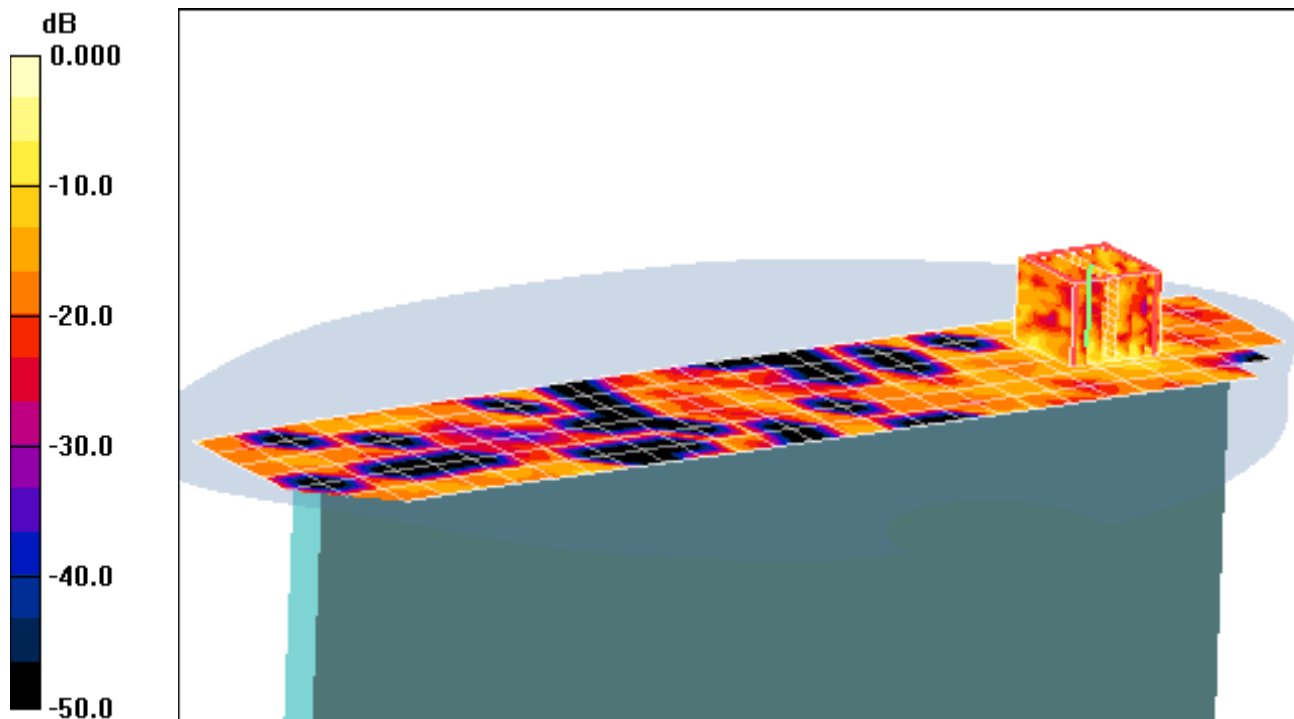

0 dB = 0.137mW/g

# PCTEST ENGINEERING LABORATORY, INC.

**DUT: A3LSCHI905; Type: Cellular/PCS CDMA/EVDO and LTE Tablet  
with Bluetooth and WLAN; Serial: FCC #3**

Communication System: IEEE 802.11a 5.2-5.8 GHz Band; Frequency: 5825 MHz; Duty Cycle: 1:1

Medium: 5 GHz Body Medium parameters used (interpolated):

$f = 5825 \text{ MHz}$ ;  $\sigma = 6.21 \text{ mho/m}$ ;  $\epsilon_r = 47.6$ ;  $\rho = 1000 \text{ kg/m}^3$

Phantom section: Flat Section; Space: 0.0 cm

Test Date: 05-03-2011; Ambient Temp: 24.0 °C; Tissue Temp: 22.7 °C

Probe: EX3DV4 - SN3550; ConvF(3.29, 3.29, 3.29); Calibrated: 2/14/2011

Sensor-Surface: 2mm (Mechanical Surface Detection)

Electronics: DAE4 Sn859; Calibrated: 7/8/2010

Phantom: SAM Main; Type: SAM 4.0; Serial: TP-1114

Measurement SW: DASY4, V4.7 Build 80; Postprocessing SW: SEMCAD, V1.8 Build 186

**Mode: IEEE 802.11a, 5.8 GHz, Body SAR, Ch 165, 6 Mbps, Right Side**

**Area Scan (7x22x1):** Measurement grid: dx=10mm, dy=10mm

**Zoom Scan (7x7x11)/Cube 0:** Measurement grid: dx=4mm, dy=4mm, dz=2mm

Reference Value = 10.9 V/m

Peak SAR (extrapolated) = 3.10 W/kg

**SAR(1 g) = 0.715 mW/g; SAR(10 g) = 0.216 mW/g**

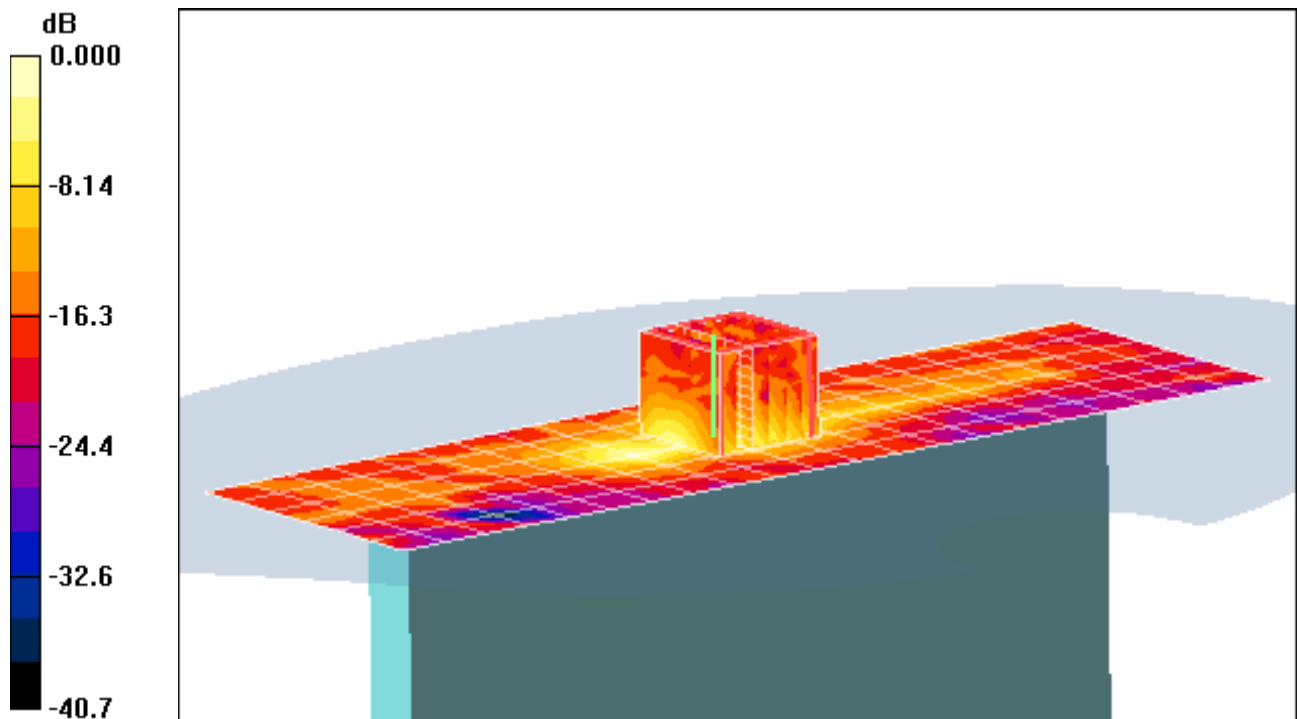

0 dB = 0.982mW/g

# PCTEST ENGINEERING LABORATORY, INC.

**DUT: A3LSCHI905; Type: Cellular/PCS CDMA/EVDO and LTE Tablet  
with Bluetooth and WLAN; Serial: FCC #3**

Communication System: IEEE 802.11a 5.2-5.8 GHz Band; Frequency: 5825 MHz; Duty Cycle: 1:1  
Medium: 5 GHz Body Medium parameters used (interpolated):  
 $f = 5825 \text{ MHz}$ ;  $\sigma = 6.21 \text{ mho/m}$ ;  $\epsilon_r = 47.6$ ;  $\rho = 1000 \text{ kg/m}^3$   
Phantom section: Flat Section; Space: 0.0 cm

Test Date: 05-03-2011; Ambient Temp: 24.0 °C; Tissue Temp: 22.7 °C

Probe: EX3DV4 - SN3550; ConvF(3.29, 3.29, 3.29); Calibrated: 2/14/2011

Sensor-Surface: 2mm (Mechanical Surface Detection)

Electronics: DAE4 Sn859; Calibrated: 7/8/2010

Phantom: SAM Main; Type: SAM 4.0; Serial: TP-1114

Measurement SW: DASY4, V4.7 Build 80; Postprocessing SW: SEMCAD, V1.8 Build 186

**Mode: IEEE 802.11a, 5.8 GHz, Body SAR, Ch 165, 6 Mbps, Right Side**

**Area Scan (7x22x1):** Measurement grid: dx=10mm, dy=10mm

**Zoom Scan (7x7x11)/Cube 0:** Measurement grid: dx=4mm, dy=4mm, dz=2mm

Reference Value = 10.9 V/m

Peak SAR (extrapolated) = 3.10 W/kg

**SAR(1 g) = 0.715 mW/g; SAR(10 g) = 0.216 mW/g**

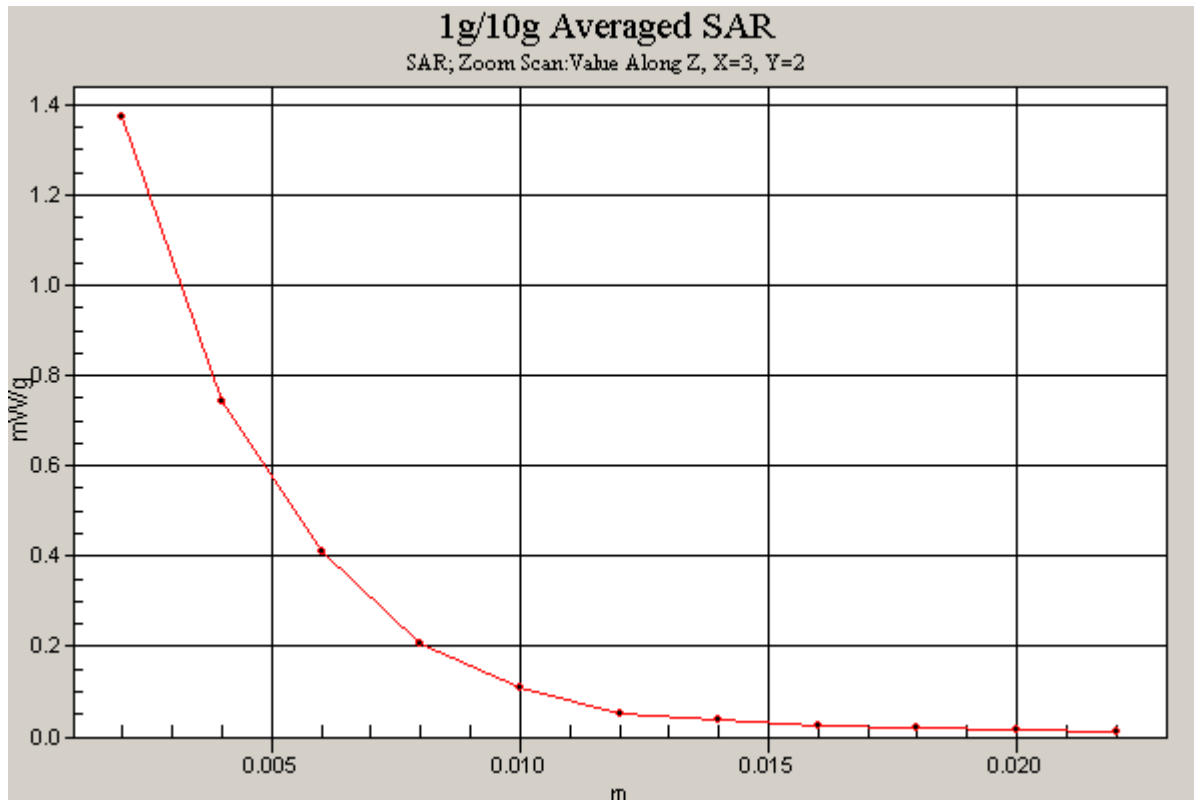

## **APPENDIX B: DIPOLE VALIDATION**

# PCTEST ENGINEERING LABORATORY, INC.

**DUT: Dipole 750 MHz; Type: D750V3; Serial: 1003**

Communication System: CW; Frequency: 750 MHz; Duty Cycle: 1:1

Medium: 740 Body Medium parameters used (interpolated):

$f = 750 \text{ MHz}$ ;  $\sigma = 0.97 \text{ mho/m}$ ;  $\epsilon_r = 56.5$ ;  $\rho = 1000 \text{ kg/m}^3$

Phantom section: Flat Section; Space: 1.5 cm

Test Date: 05-03-2011; Ambient Temp: 23.4 °C; Tissue Temp: 21.8 °C

Probe: ES3DV2 - SN3022; ConvF(6.09, 6.09, 6.09); Calibrated: 9/21/2010

Sensor-Surface: 4mm (Mechanical Surface Detection)

Electronics: DAE4 Sn704; Calibrated: 3/17/2011

Phantom: SAM with CRP; Type: SAM; Serial: TP1375

Measurement SW: DASY4, V4.7 Build 80; Postprocessing SW: SEMCAD, V1.8 Build 186

## 750MHz System Verification

**Area Scan (7x13x1):** Measurement grid: dx=15mm, dy=15mm

**Zoom Scan (5x5x7)/Cube 0:** Measurement grid: dx=8mm, dy=8mm, dz=5mm

Input Power = 24.0 dBm (250 mW)

**SAR(1 g) = 2.16 mW/g; SAR(10 g) = 1.42 mW/g**

Deviation = -2.37 %

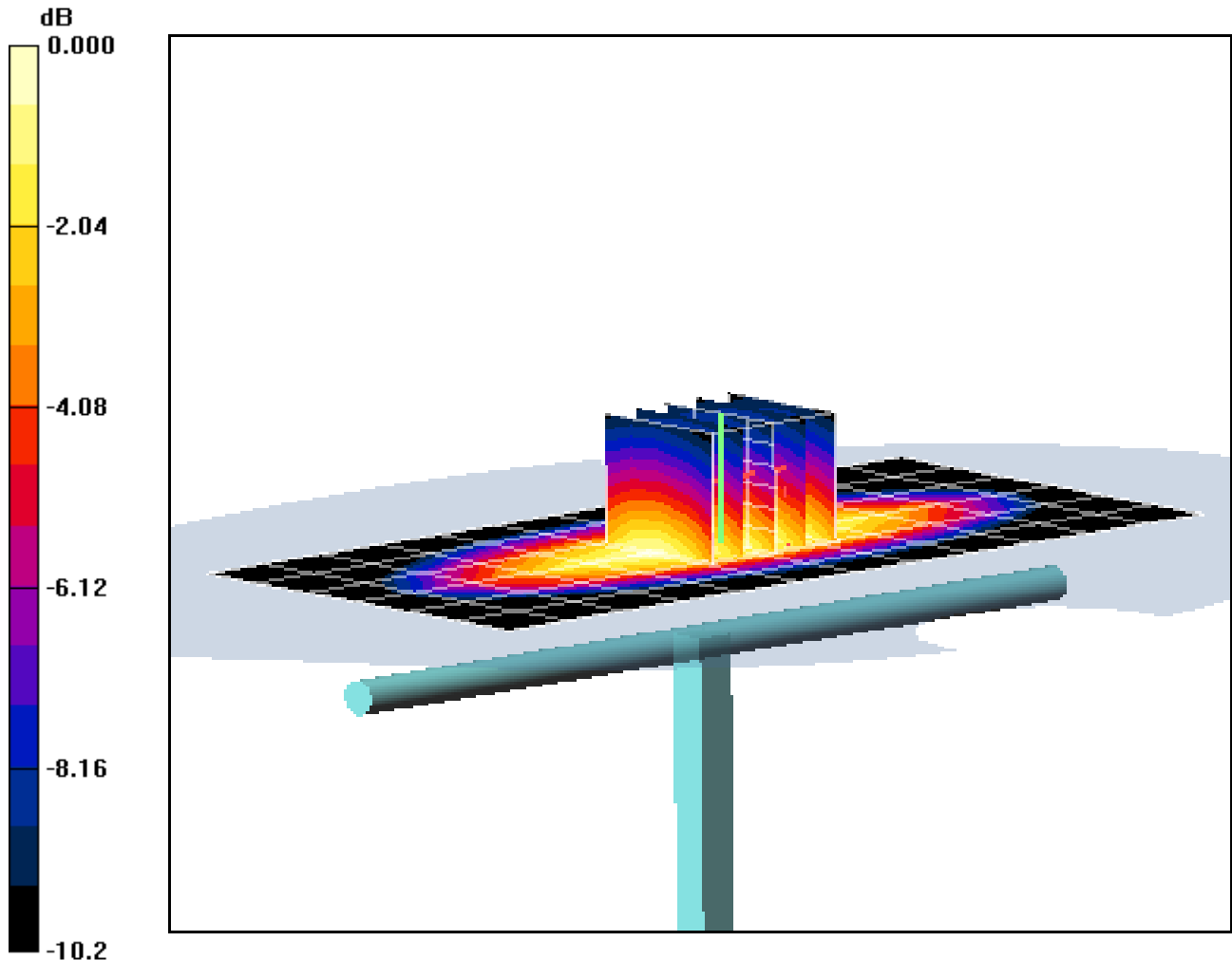

0 dB = 2.32mW/g

# PCTEST ENGINEERING LABORATORY, INC.

**DUT: Dipole 835 MHz; Type: D835V2; Serial: 4d047**

Communication System: CW; Frequency: 835 MHz; Duty Cycle: 1:1

Medium: 835 Body Medium parameters used:

$f = 835 \text{ MHz}$ ;  $\sigma = 0.957 \text{ mho/m}$ ;  $\epsilon_r = 53.1$ ;  $\rho = 1000 \text{ kg/m}^3$

Phantom section: Flat Section; Space: 1.5 cm

Test Date: 05-04-2011; Ambient Temp: 24.2 °C; Tissue Temp: 22.4 °C

Probe: EX3DV4 - SN3561; ConvF(8.09, 8.09, 8.09); Calibrated: 8/19/2010

Sensor-Surface: 4mm (Mechanical Surface Detection)

Electronics: DAE4 Sn649; Calibrated: 2/21/2011

Phantom: SAM Main; Type: SAM 4.0; Serial: TP-1406

Measurement SW: DASY4, V4.7 Build 80; Postprocessing SW: SEMCAD, V1.8 Build 186

## 835MHz System Verification

**Area Scan (7x13x1):** Measurement grid: dx=15mm, dy=15mm

**Zoom Scan (5x5x7)/Cube 0:** Measurement grid: dx=8mm, dy=8mm, dz=5mm

Input Power = 18.0 dBm (63 mW)

**SAR(1 g) = 0.617 mW/g; SAR(10 g) = 0.406 mW/g**

Deviation = -0.57 %

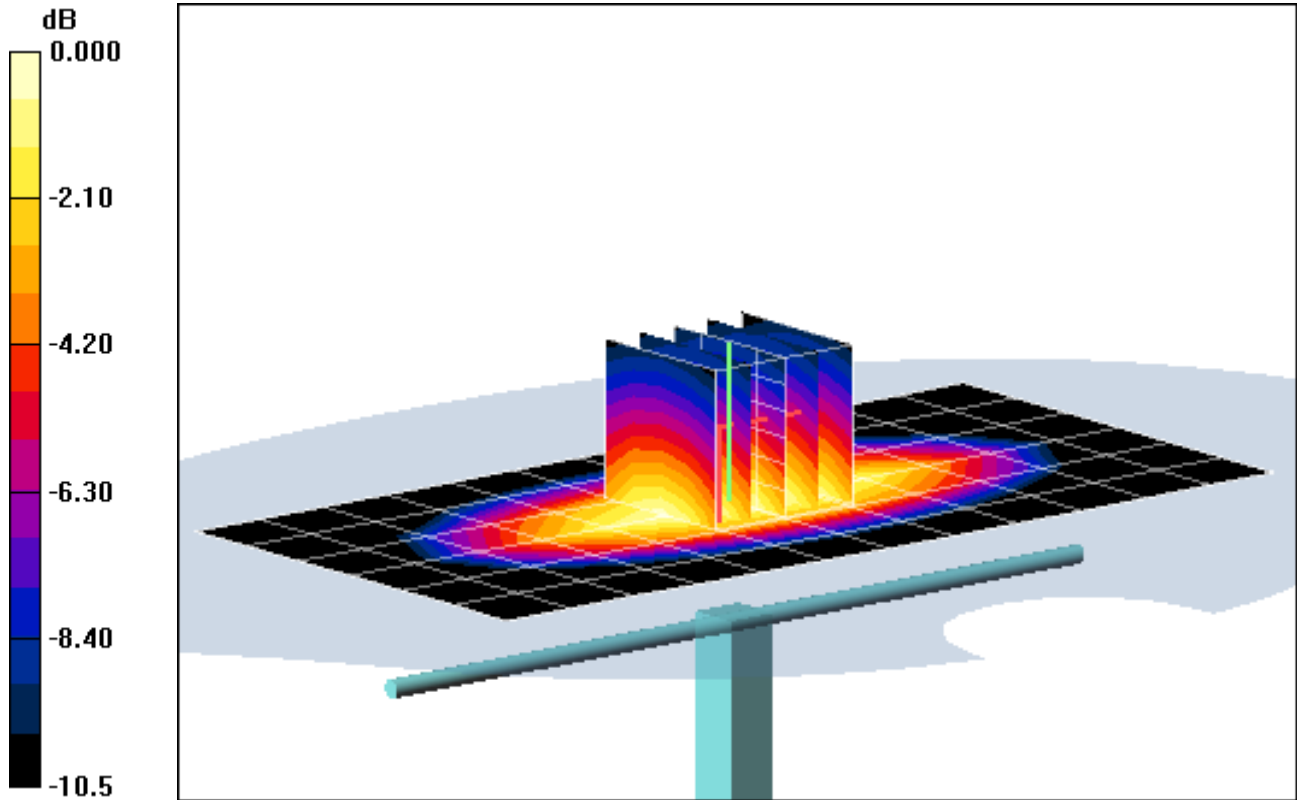

0 dB = 0.666mW/g

# PCTEST ENGINEERING LABORATORY, INC.

**DUT: SAR Dipole 1900 MHz; Type: D1900V2; Serial: 502**

Communication System: CW; Frequency: 1900 MHz; Duty Cycle: 1:1

Medium: 1900 Body Medium parameters used (interpolated):

$f = 1900 \text{ MHz}$ ;  $\sigma = 1.52 \text{ mho/m}$ ;  $\epsilon_r = 52.3$ ;  $\rho = 1000 \text{ kg/m}^3$

Phantom section: Flat Section; Space: 1.0 cm

Test Date: 05-02-2011; Ambient Temp: 24.0 °C; Tissue Temp: 22.8 °C

Probe: EX3DV4 - SN3561; ConvF(6.59, 6.59, 6.59); Calibrated: 8/19/2010

Sensor-Surface: 4mm (Mechanical Surface Detection)

Electronics: DAE4 Sn649; Calibrated: 2/21/2011

Phantom: SAM Sub; Type: SAM 4.0; Serial: TP-1357

Measurement SW: DASY4, V4.7 Build 80; Postprocessing SW: SEMCAD, V1.8 Build 186

## 1900MHz System Verification

**Area Scan (5x7x1):** Measurement grid: dx=15mm, dy=15mm

**Zoom Scan (5x5x7)/Cube 0:** Measurement grid: dx=8mm, dy=8mm, dz=5mm

Input Power = 16.0 dBm (40 mW)

**SAR(1 g) = 1.66 mW/g; SAR(10 g) = 0.857 mW/g**

Deviation = 0.97 %

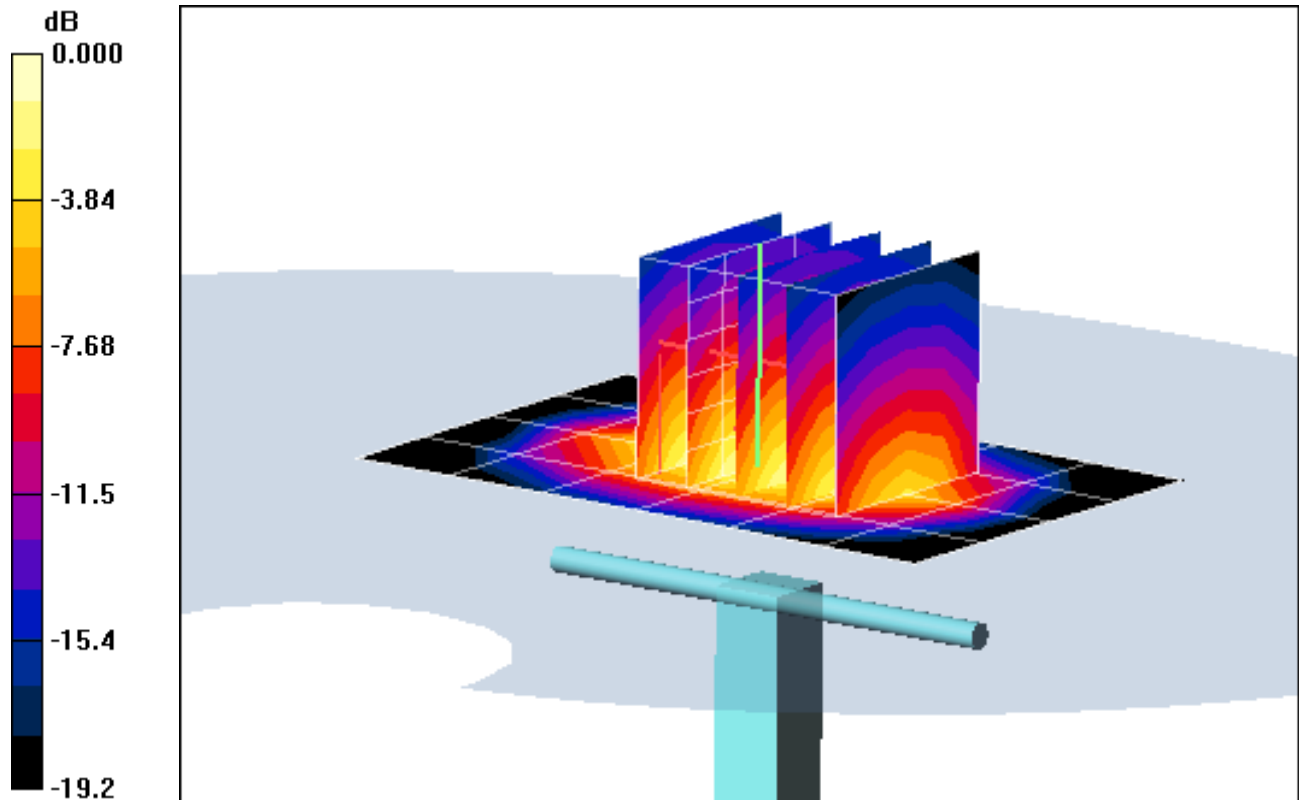

0 dB = 1.88mW/g

# PCTEST ENGINEERING LABORATORY, INC.

**DUT: SAR Dipole 2450 MHz; Type: D2450V2; Serial: 797**

Communication System: CW; Frequency: 2450 MHz; Duty Cycle: 1:1

Medium: 2450 Body Medium parameters used:

$f = 2450 \text{ MHz}$ ;  $\sigma = 2.01 \text{ mho/m}$ ;  $\epsilon_r = 50.2$ ;  $\rho = 1000 \text{ kg/m}^3$

Phantom section: Flat Section; Space: 1.0 cm

Test Date: 05-03-2011; Ambient Temp: 24.3 °C; Tissue Temp: 22.9 °C

Probe: EX3DV4 - SN3550; ConvF(6.25, 6.25, 6.25); Calibrated: 2/14/2011

Sensor-Surface: 3mm (Mechanical Surface Detection)

Electronics: DAE4 Sn859; Calibrated: 7/8/2010

Phantom: SAM Sub; Type: SAM 4.0; Serial: TP-1357

Measurement SW: DASY4, V4.7 Build 80; Postprocessing SW: SEMCAD, V1.8 Build 186

## 2450MHz System Verification

**Area Scan (5x7x1):** Measurement grid: dx=15mm, dy=15mm

**Zoom Scan (5x5x7)/Cube 0:** Measurement grid: dx=8mm, dy=8mm, dz=5mm

Input Power = 14.0 dBm (25 mW)

**SAR(1 g) = 1.38 mW/g; SAR(10 g) = 0.647 mW/g**

Deviation = 5.54 %

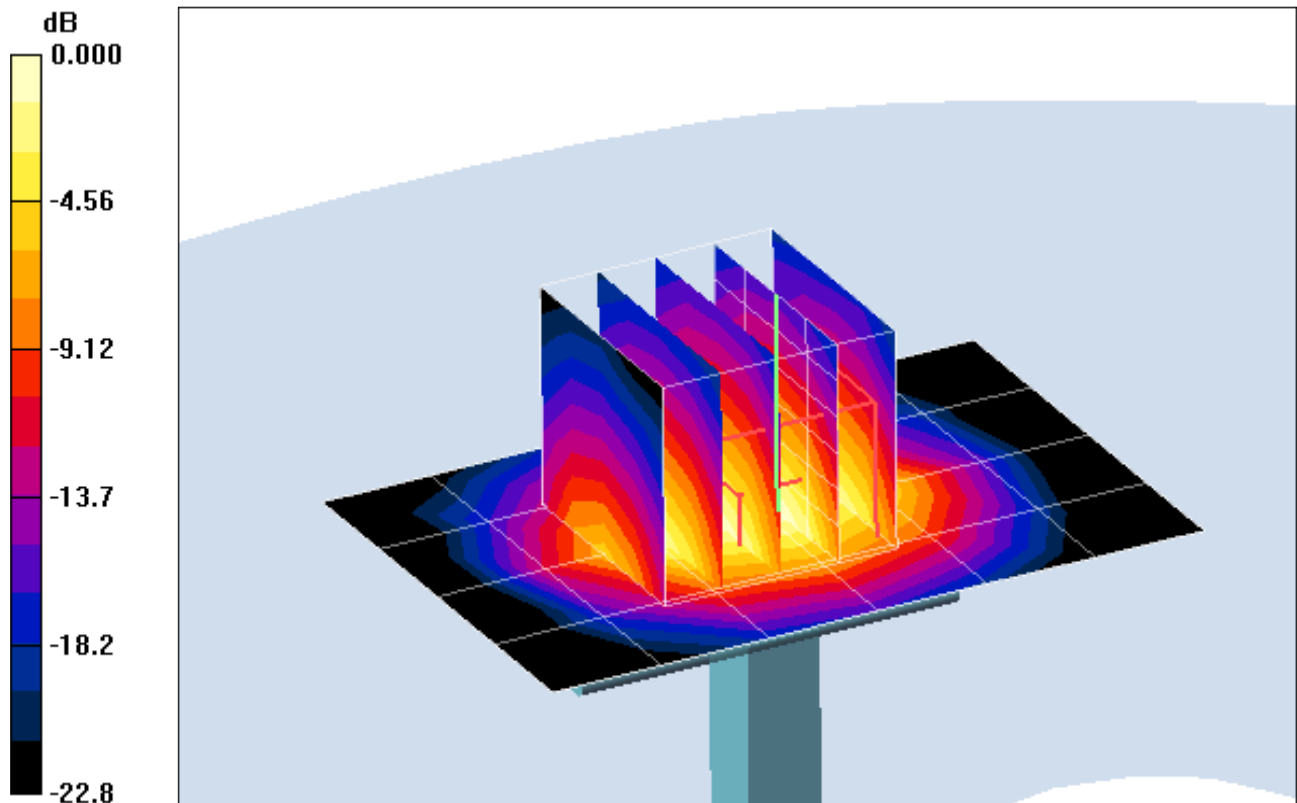

0 dB = 1.77mW/g

# PCTEST ENGINEERING LABORATORY, INC.

**DUT: Dipole 5200 MHz; Type: D5GHzV2; Serial: 1057**

Communication System: CW; Frequency: 5200 MHz; Duty Cycle: 1:1

Medium: 5 GHz Body Medium parameters used (interpolated):

$f = 5200 \text{ MHz}$ ;  $\sigma = 5.3 \text{ mho/m}$ ;  $\epsilon_r = 49$ ;  $\rho = 1000 \text{ kg/m}^3$

Phantom section: Flat Section; Space: 1.0 cm

Test Date: 05-03-2011; Ambient Temp: 23.6 °C; Tissue Temp: 22.3 °C

Probe: EX3DV4 - SN3550; ConvF(3.58, 3.58, 3.58); Calibrated: 2/14/2011

Sensor-Surface: 2mm (Mechanical Surface Detection)

Electronics: DAE4 Sn859; Calibrated: 7/8/2010

Phantom: SAM Main; Type: SAM 4.0; Serial: TP-1114

Measurement SW: DASY4, V4.7 Build 80; Postprocessing SW: SEMCAD, V1.8 Build 186

## 5200MHz System Verification

**Area Scan (7x9x1):** Measurement grid: dx=10mm, dy=10mm

**Zoom Scan (7x7x11)/Cube 0:** Measurement grid: dx=4mm, dy=4mm, dz=2mm

Input Power = 14.0 dBm (25 mW)

**SAR(1 g) = 1.92 mW/g; SAR(10 g) = 0.532 mW/g**

Deviation = -1.16 %

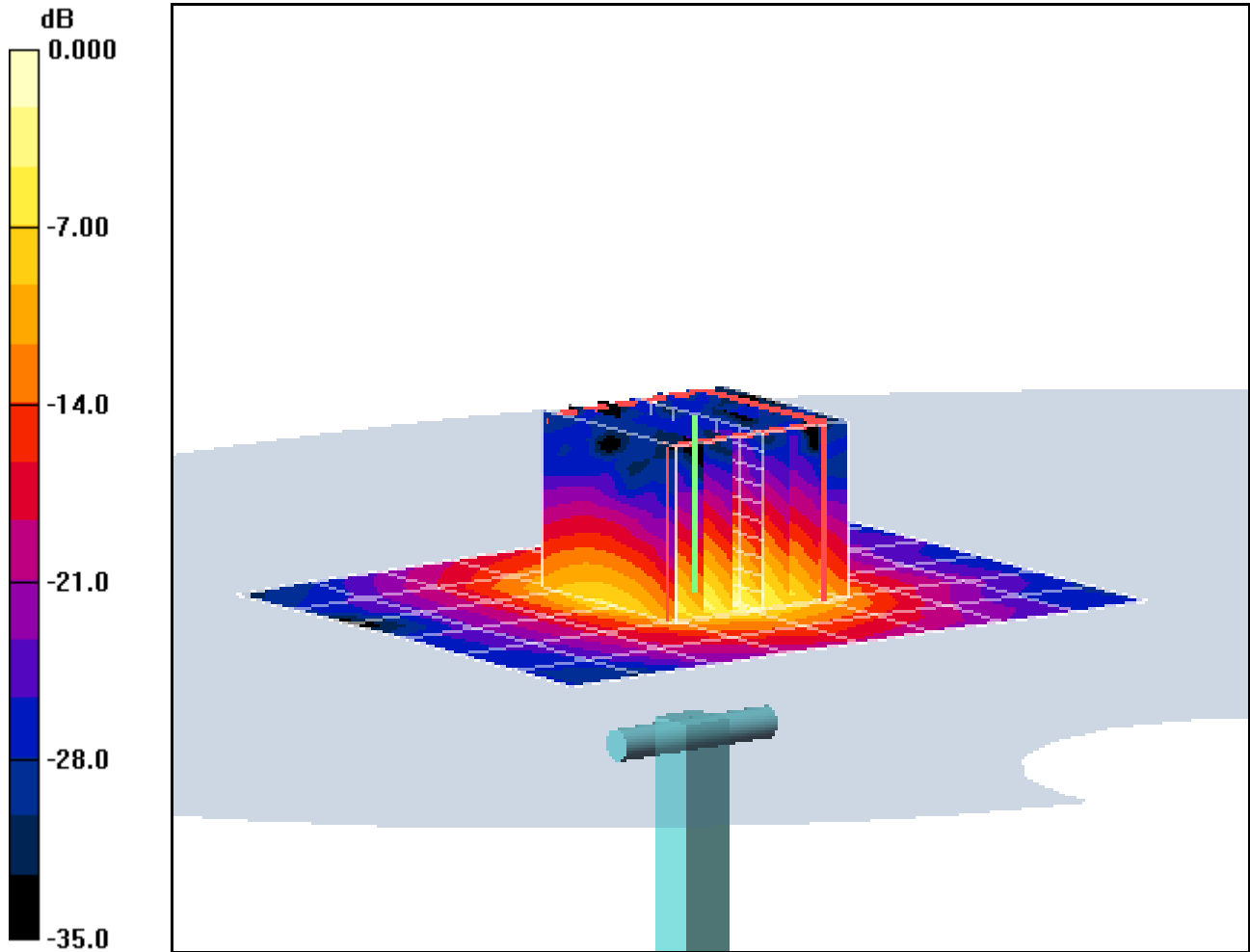

0 dB = 3.96mW/g

# PCTEST ENGINEERING LABORATORY, INC.

**DUT: Dipole 5500 MHz; Type: D5GHzV2; Serial: 1057**

Communication System: CW; Frequency: 5500 MHz; Duty Cycle: 1:1

Medium: 5 GHz Body Medium parameters used (interpolated):

$f = 5500 \text{ MHz}$ ;  $\sigma = 5.75 \text{ mho/m}$ ;  $\epsilon_r = 48.4$ ;  $\rho = 1000 \text{ kg/m}^3$

Phantom section: Flat Section; Space: 1.0 cm

Test Date: 05-03-2011; Ambient Temp: 23.8 °C; Tissue Temp: 22.5 °C

Probe: EX3DV4 - SN3550; ConvF(3.21, 3.21, 3.21); Calibrated: 2/14/2011

Sensor-Surface: 2mm (Mechanical Surface Detection)

Electronics: DAE4 Sn859; Calibrated: 7/8/2010

Phantom: SAM Main; Type: SAM 4.0; Serial: TP-1114

Measurement SW: DASY4, V4.7 Build 80; Postprocessing SW: SEMCAD, V1.8 Build 186

## 5500MHz System Verification

**Area Scan (7x9x1):** Measurement grid: dx=10mm, dy=10mm

**Zoom Scan (7x7x11)/Cube 0:** Measurement grid: dx=4mm, dy=4mm, dz=2mm

Input Power = 14.0 dBm (25 mW)

**SAR(1 g) = 2.04 mW/g; SAR(10 g) = 0.557 mW/g**

Deviation = -3.32 %

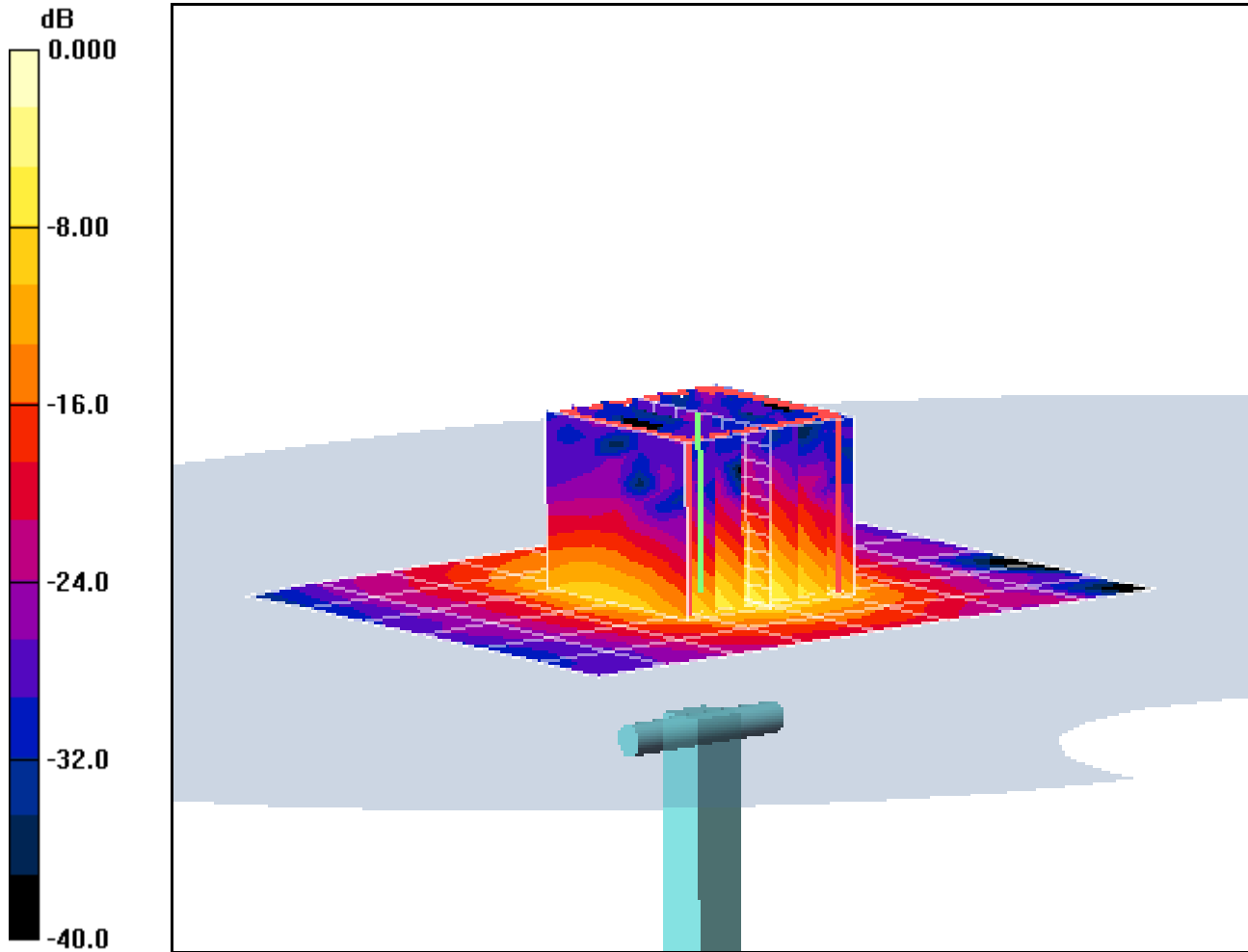

0 dB = 4.13mW/g

# PCTEST ENGINEERING LABORATORY, INC.

**DUT: Dipole 5800 MHz; Type: D5GHzV2; Serial: 1057**

Communication System: CW; Frequency: 5800 MHz; Duty Cycle: 1:1

Medium: 5 GHz Body Medium parameters used (interpolated):

$f = 5800 \text{ MHz}$ ;  $\sigma = 6.17 \text{ mho/m}$ ;  $\epsilon_r = 47.7$ ;  $\rho = 1000 \text{ kg/m}^3$

Phantom section: Flat Section; Space: 1.0 cm

Test Date: 05-03-2011; Ambient Temp: 24.0 °C; Tissue Temp: 22.7 °C

Probe: EX3DV4 - SN3550; ConvF(3.29, 3.29, 3.29); Calibrated: 2/14/2011

Sensor-Surface: 2mm (Mechanical Surface Detection)

Electronics: DAE4 Sn859; Calibrated: 7/8/2010

Phantom: SAM Main; Type: SAM 4.0; Serial: TP-1114

Measurement SW: DASY4, V4.7 Build 80; Postprocessing SW: SEMCAD, V1.8 Build 186

## 5800MHz System Verification

**Area Scan (7x9x1):** Measurement grid: dx=10mm, dy=10mm

**Zoom Scan (7x7x11)/Cube 0:** Measurement grid: dx=4mm, dy=4mm, dz=2mm

Input Power = 14.0 dBm (25 mW)

**SAR(1 g) = 1.84 mW/g; SAR(10 g) = 0.503 mW/g**

Deviation = -1.87 %

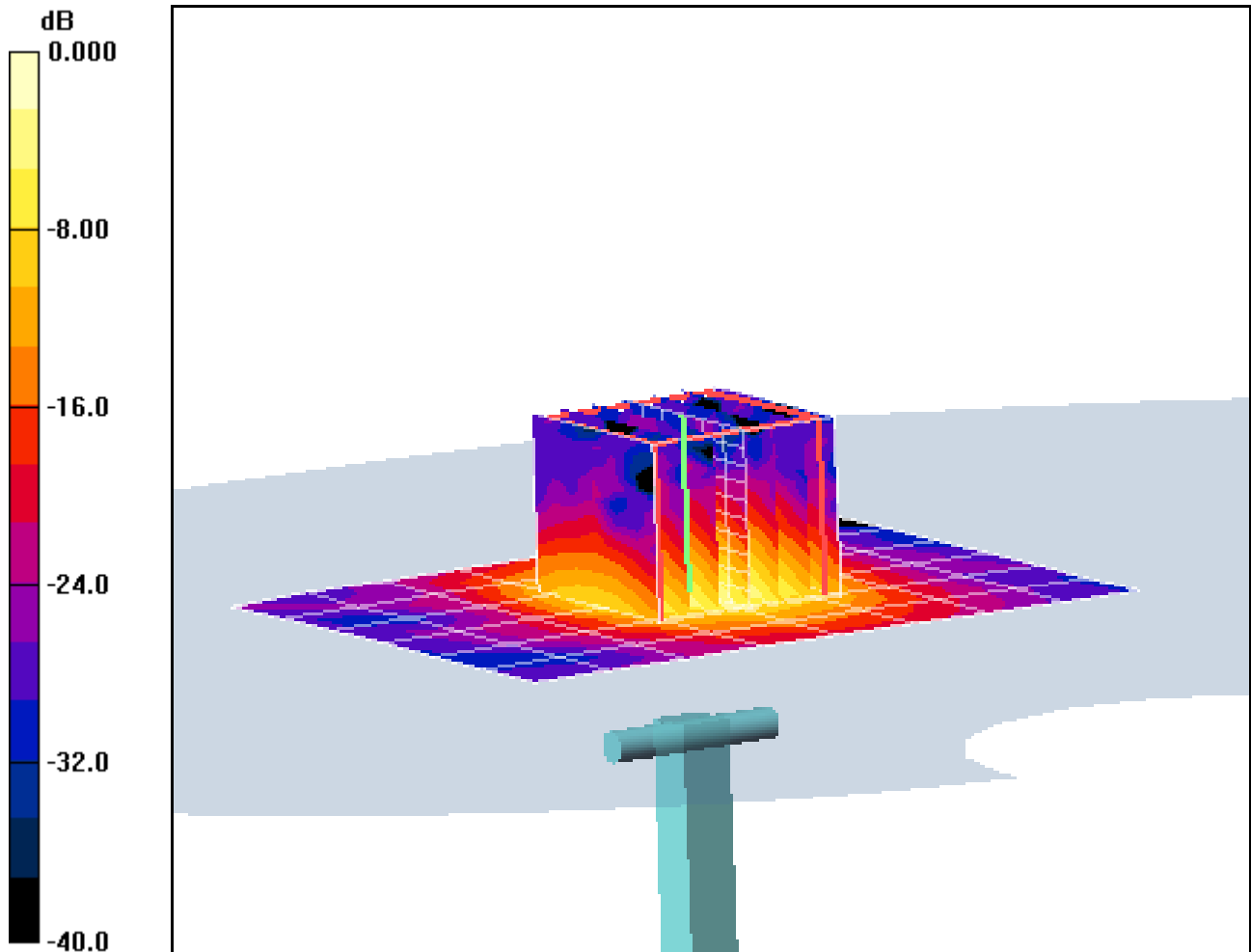

0 dB = 3.96mW/g

## **APPENDIX C: PROBE CALIBRATION**



Accredited by the Swiss Accreditation Service (SAS)  
The Swiss Accreditation Service is one of the signatories to the EA  
Multilateral Agreement for the recognition of calibration certificates

Accreditation No.: **SCS 108**

Client **PC Test**

Certificate No: **ES3-3022\_Sep10**

## CALIBRATION CERTIFICATE

Object **ES3DV2 - SN:3022**

Calibration procedure(s) **QA CAL-01.v6, QA CAL-23.v3 and QA CAL-25.v2  
Calibration procedure for dosimetric E-field probes**

Calibration date: **September 21, 2010**

✓  
KOK  
9/29/10

This calibration certificate documents the traceability to national standards, which realize the physical units of measurements (SI).  
The measurements and the uncertainties with confidence probability are given on the following pages and are part of the certificate.

All calibrations have been conducted in the closed laboratory facility: environment temperature (22 ± 3)°C and humidity < 70%.

Calibration Equipment used (M&TE critical for calibration)

Primary Standards	ID #	Cal Date (Certificate No.)	Scheduled Calibration
Power meter E4419B	GB41293874	1-Apr-10 (No. 217-01136)	Apr-11
Power sensor E4412A	MY41495277	1-Apr-10 (No. 217-01136)	Apr-11
Power sensor E4412A	MY41498087	1-Apr-10 (No. 217-01136)	Apr-11
Reference 3 dB Attenuator	SN: S5054 (3c)	30-Mar-10 (No. 217-01159)	Mar-11
Reference 20 dB Attenuator	SN: S5086 (20b)	30-Mar-10 (No. 217-01161)	Mar-11
Reference 30 dB Attenuator	SN: S5129 (30b)	30-Mar-10 (No. 217-01160)	Mar-11
Reference Probe ES3DV2	SN: 3013	30-Dec-09 (No. ES3-3013_Dec09)	Dec-10
DAE4	SN: 660	20-Apr-10 (No. DAE4-660_Apr10)	Apr-11
Secondary Standards	ID #	Check Date (in house)	Scheduled Check
RF generator HP 8648C	US3642U01700	4-Aug-99 (in house check Oct-09)	In house check: Oct-11
Network Analyzer HP 8753E	US37390585	18-Oct-01 (in house check Oct-09)	In house check: Oct10

	Name	Function	Signature
Calibrated by:	Jeton Kastrati	Laboratory Technician	
Approved by:	Katja Pokovic	Technical Manager	

Issued: September 22, 2010

This calibration certificate shall not be reproduced except in full without written approval of the laboratory.



Accredited by the Swiss Accreditation Service (SAS)  
The Swiss Accreditation Service is one of the signatories to the EA  
Multilateral Agreement for the recognition of calibration certificates

Accreditation No.: **SCS 108**

### Glossary:

TSL	tissue simulating liquid
NORM <sub>x,y,z</sub>	sensitivity in free space
ConvF	sensitivity in TSL / NORM <sub>x,y,z</sub>
DCP	diode compression point
CF	crest factor (1/duty_cycle) of the RF signal
A, B, C	modulation dependent linearization parameters
Polarization $\varphi$	$\varphi$ rotation around probe axis
Polarization $\vartheta$	$\vartheta$ rotation around an axis that is in the plane normal to probe axis (at measurement center), i.e., $\vartheta = 0$ is normal to probe axis

### Calibration is Performed According to the Following Standards:

- IEEE Std 1528-2003, "IEEE Recommended Practice for Determining the Peak Spatial-Averaged Specific Absorption Rate (SAR) in the Human Head from Wireless Communications Devices: Measurement Techniques", December 2003
- IEC 62209-1, "Procedure to measure the Specific Absorption Rate (SAR) for hand-held devices used in close proximity to the ear (frequency range of 300 MHz to 3 GHz)", February 2005

### Methods Applied and Interpretation of Parameters:

- NORM<sub>x,y,z</sub>**: Assessed for E-field polarization  $\vartheta = 0$  ( $f \leq 900$  MHz in TEM-cell;  $f > 1800$  MHz: R22 waveguide). NORM<sub>x,y,z</sub> are only intermediate values, i.e., the uncertainties of NORM<sub>x,y,z</sub> does not effect the  $E^2$ -field uncertainty inside TSL (see below *ConvF*).
- NORM(f)<sub>x,y,z</sub> = NORM<sub>x,y,z</sub> \* frequency\_response** (see Frequency Response Chart). This linearization is implemented in DASY4 software versions later than 4.2. The uncertainty of the frequency response is included in the stated uncertainty of *ConvF*.
- DCP<sub>x,y,z</sub>**: DCP are numerical linearization parameters assessed based on the data of power sweep with CW signal (no uncertainty required). DCP does not depend on frequency nor media.
- A<sub>x,y,z</sub>; B<sub>x,y,z</sub>; C<sub>x,y,z</sub>; VR<sub>x,y,z</sub>; A, B, C** are numerical linearization parameters assessed based on the data of power sweep for specific modulation signal. The parameters do not depend on frequency nor media. VR is the maximum calibration range expressed in RMS voltage across the diode.
- ConvF and Boundary Effect Parameters**: Assessed in flat phantom using E-field (or Temperature Transfer Standard for  $f \leq 800$  MHz) and inside waveguide using analytical field distributions based on power measurements for  $f > 800$  MHz. The same setups are used for assessment of the parameters applied for boundary compensation (alpha, depth) of which typical uncertainty values are given. These parameters are used in DASY4 software to improve probe accuracy close to the boundary. The sensitivity in TSL corresponds to **NORM<sub>x,y,z</sub> \* ConvF** whereby the uncertainty corresponds to that given for *ConvF*. A frequency dependent *ConvF* is used in DASY version 4.4 and higher which allows extending the validity from  $\pm 50$  MHz to  $\pm 100$  MHz.
- Spherical isotropy (3D deviation from isotropy)**: in a field of low gradients realized using a flat phantom exposed by a patch antenna.
- Sensor Offset**: The sensor offset corresponds to the offset of virtual measurement center from the probe tip (on probe axis). No tolerance required.

# Probe ES3DV2

## SN:3022

Manufactured:	April 15, 2003
Last calibrated:	September 18, 2009
Recalibrated:	September 21, 2010

Calibrated for DASY/EASY Systems

(Note: non-compatible with DASY2 system!)

**DASY/EASY - Parameters of Probe: ES3DV2 SN:3022****Basic Calibration Parameters**

	Sensor X	Sensor Y	Sensor Z	Unc (k=2)
Norm ( $\mu\text{V}/(\text{V}/\text{m})^2$ ) <sup>A</sup>	1.01	1.05	1.01	± 10.1%
DCP (mV) <sup>B</sup>	92.8	92.5	89.7	

**Modulation Calibration Parameters**

UID	Communication System Name	PAR		A dB	B dBuV	C	VR mV	Unc <sup>E</sup> (k=2)
10000	CW	0.00	X	0.00	0.00	1.00	300.0	± 1.5%
			Y	0.00	0.00	1.00	300.0	
			Z	0.00	0.00	1.00	300.0	

The reported uncertainty of measurement is stated as the standard uncertainty of measurement multiplied by the coverage factor k=2, which for a normal distribution corresponds to a coverage probability of approximately 95%.

<sup>A</sup> The uncertainties of NormX,Y,Z do not affect the E<sup>2</sup>-field uncertainty inside TSL (see Pages 5 and 6).

<sup>B</sup> Numerical linearization parameter: uncertainty not required.

<sup>E</sup> Uncertainty is determined using the maximum deviation from linear response applying recatangular distribution and is expressed for the square of the field value.

## DASY/EASY - Parameters of Probe: ES3DV2 SN:3022

### Calibration Parameter Determined in Head Tissue Simulating Media

f [MHz]	Validity [MHz] <sup>c</sup>	Permittivity	Conductivity	ConvF X	ConvF Y	ConvF Z	Alpha	Depth Unc (k=2)
750	± 50 / ± 100	41.9 ± 5%	0.89 ± 5%	6.32	6.32	6.32	0.87	1.01 ± 11.0%
835	± 50 / ± 100	41.5 ± 5%	0.90 ± 5%	6.02	6.02	6.02	0.62	1.20 ± 11.0%
1750	± 50 / ± 100	40.1 ± 5%	1.37 ± 5%	5.01	5.01	5.01	0.27	2.23 ± 11.0%
1900	± 50 / ± 100	40.0 ± 5%	1.40 ± 5%	4.83	4.83	4.83	0.25	2.29 ± 11.0%
2450	± 50 / ± 100	39.2 ± 5%	1.80 ± 5%	4.21	4.21	4.21	0.25	2.62 ± 11.0%
2600	± 50 / ± 100	39.0 ± 5%	1.96 ± 5%	4.14	4.14	4.14	0.25	2.64 ± 11.0%

<sup>c</sup> The validity of ± 100 MHz only applies for DASY v4.4 and higher (see Page 2). The uncertainty is the RSS of the ConvF uncertainty at calibration frequency and the uncertainty for the indicated frequency band.

## DASY/EASY - Parameters of Probe: ES3DV2 SN:3022

### Calibration Parameter Determined in Body Tissue Simulating Media

f [MHz]	Validity [MHz] <sup>c</sup>	Permittivity	Conductivity	ConvF X	ConvF Y	ConvF Z	Alpha	Depth Unc (k=2)
750	± 50 / ± 100	55.5 ± 5%	0.96 ± 5%	6.09	6.09	6.09	0.68	1.20 ± 11.0%
835	± 50 / ± 100	55.2 ± 5%	0.97 ± 5%	5.89	5.89	5.89	0.65	1.20 ± 11.0%
1750	± 50 / ± 100	53.4 ± 5%	1.49 ± 5%	4.59	4.59	4.59	0.23	2.83 ± 11.0%
1900	± 50 / ± 100	53.3 ± 5%	1.52 ± 5%	4.34	4.34	4.34	0.22	3.71 ± 11.0%
2450	± 50 / ± 100	52.7 ± 5%	1.95 ± 5%	4.06	4.06	4.06	0.41	1.42 ± 11.0%
2600	± 50 / ± 100	52.5 ± 5%	2.16 ± 5%	4.06	4.06	4.06	0.53	1.23 ± 11.0%

<sup>c</sup> The validity of ± 100 MHz only applies for DASY v4.4 and higher (see Page 2). The uncertainty is the RSS of the ConvF uncertainty at calibration frequency and the uncertainty for the indicated frequency band.

### Frequency Response of E-Field

(TEM-Cell:ifi110 EXX, Waveguide: R22)

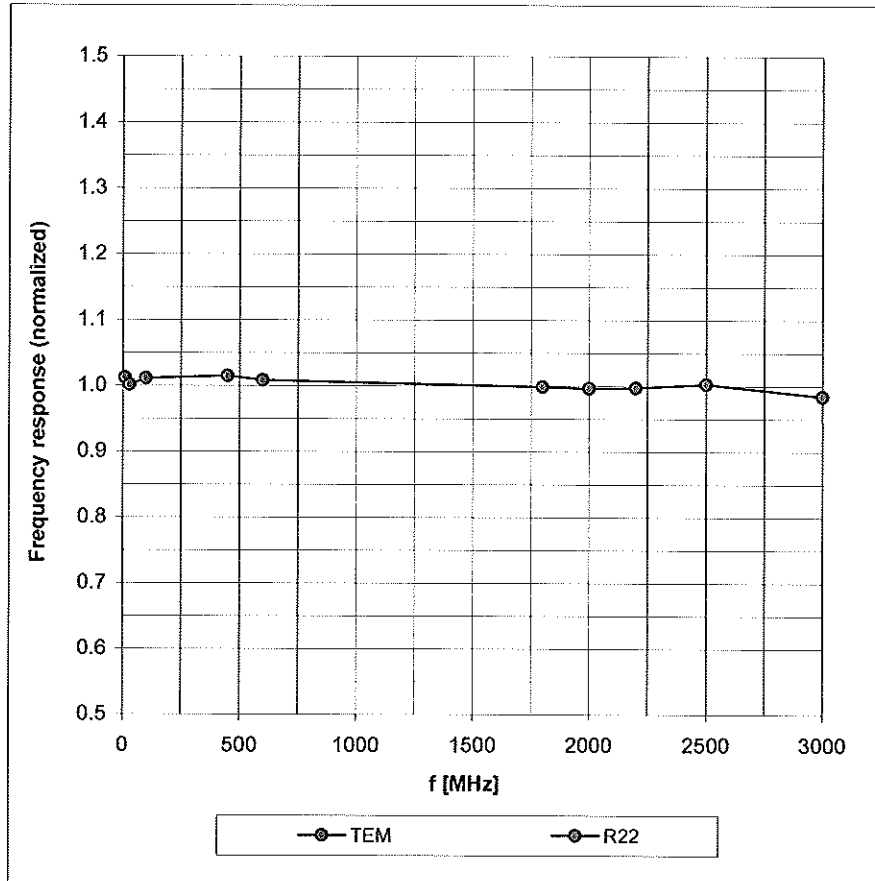

Uncertainty of Frequency Response of E-field:  $\pm 6.3\%$  (k=2)

### Receiving Pattern ( $\phi$ ), $\vartheta = 0^\circ$

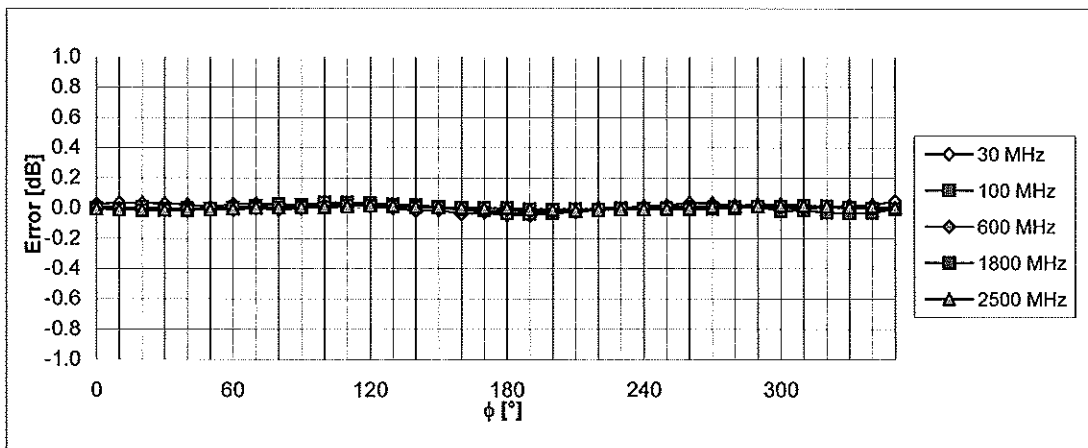
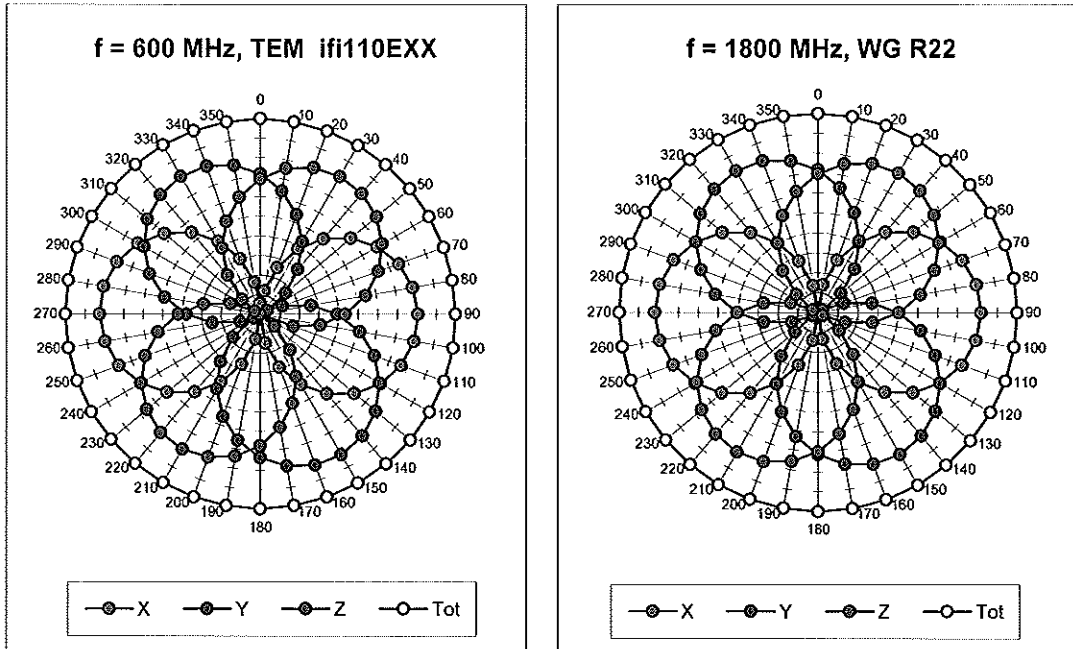

Uncertainty of Axial Isotropy Assessment:  $\pm 0.5\%$  ( $k=2$ )

### Dynamic Range $f(SAR_{head})$ (Waveguide R22, $f = 1800$ MHz)

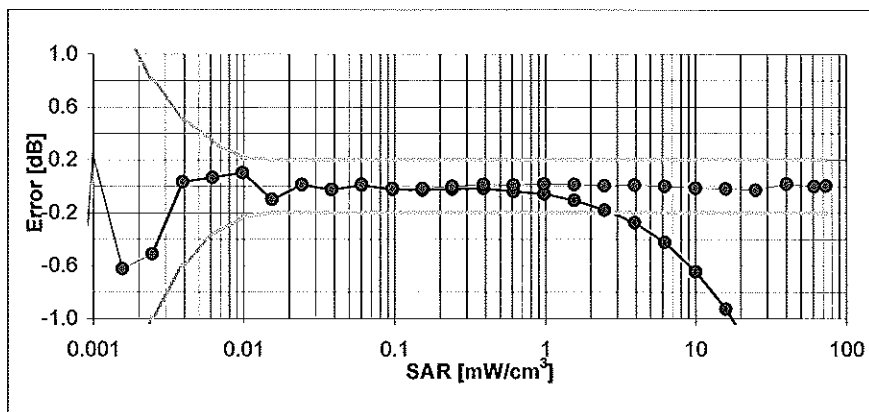
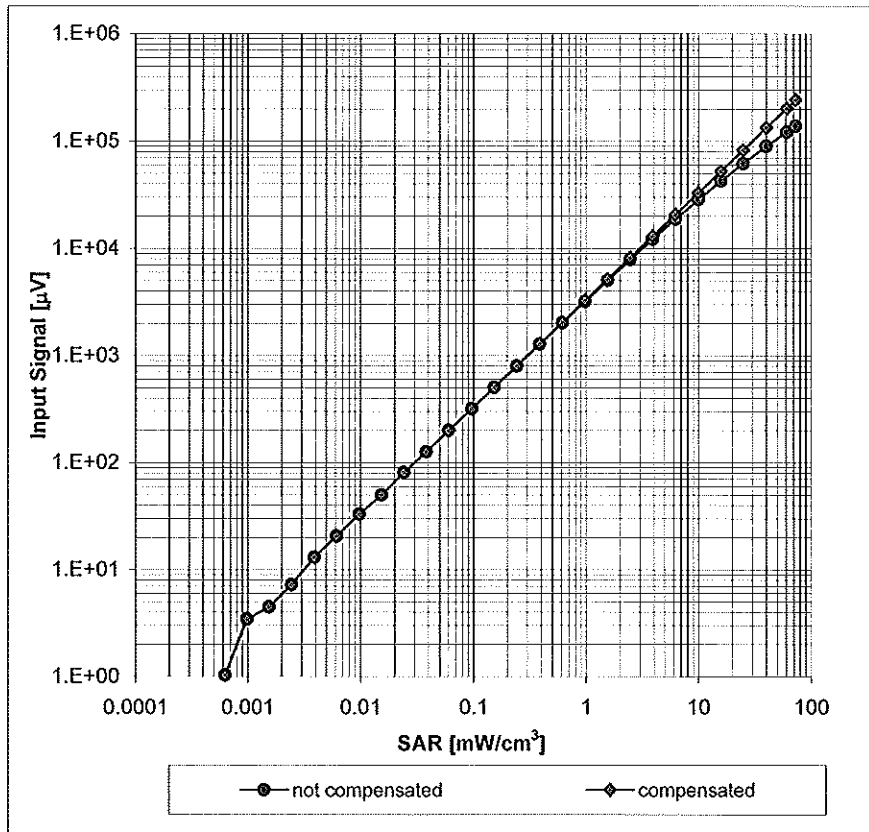

Uncertainty of Linearity Assessment:  $\pm 0.6\%$  ( $k=2$ )

### Conversion Factor Assessment

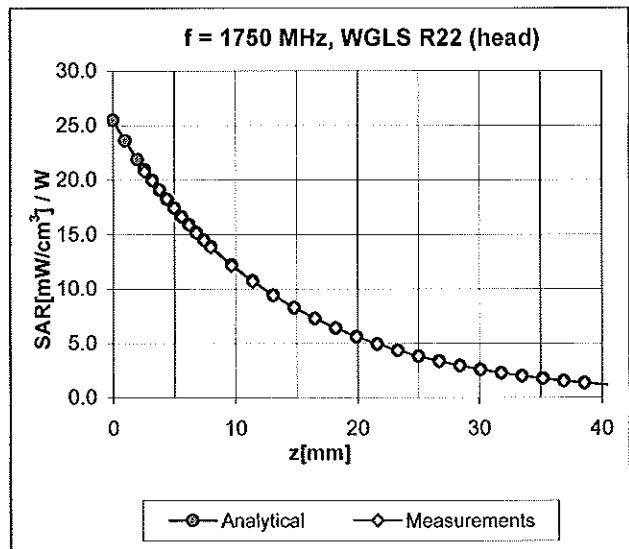
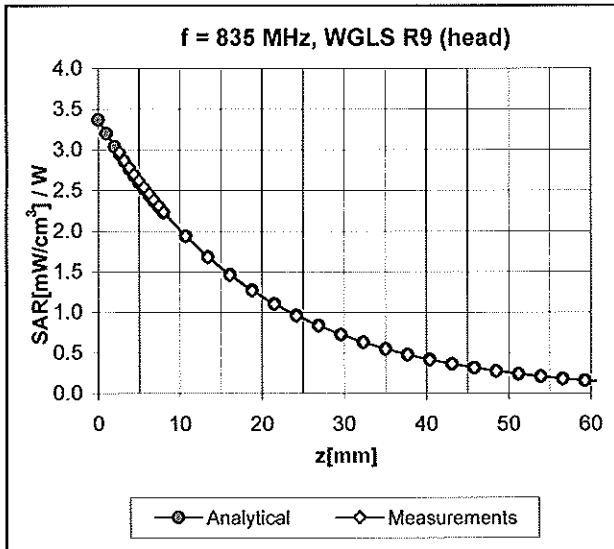

### Deviation from Isotropy in HSL

Error ( $\phi, \theta$ ), f = 900 MHz

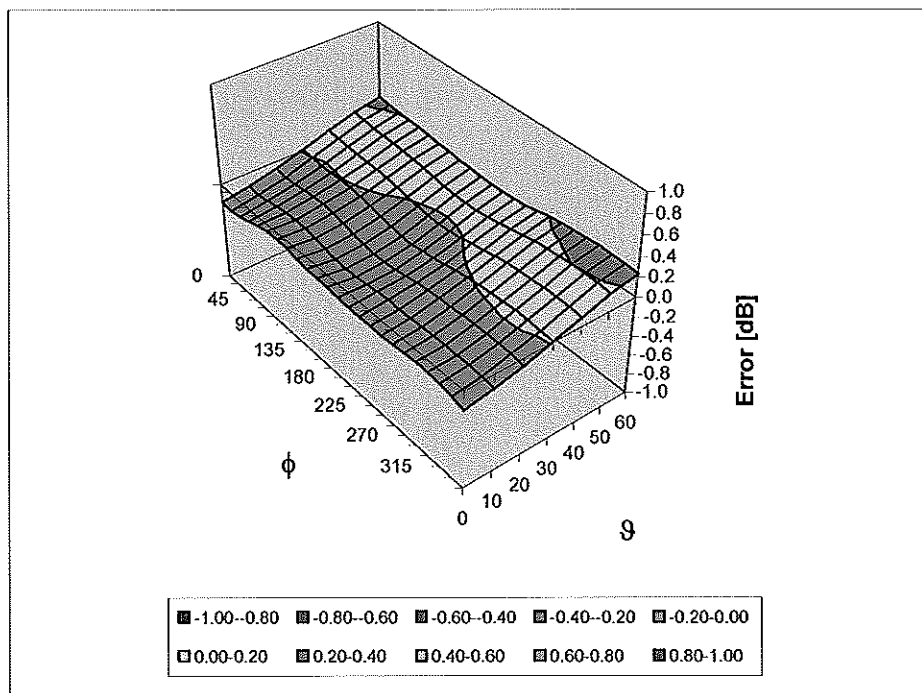

Uncertainty of Spherical Isotropy Assessment:  $\pm 2.6\%$  (k=2)

## Other Probe Parameters

Sensor Arrangement	Triangular
Connector Angle (°)	Not applicable
Mechanical Surface Detection Mode	enabled
Optical Surface Detection Mode	disabled
Probe Overall Length	337 mm
Probe Body Diameter	10 mm
Tip Length	10 mm
Tip Diameter	4.0 mm
Probe Tip to Sensor X Calibration Point	2 mm
Probe Tip to Sensor Y Calibration Point	2 mm
Probe Tip to Sensor Z Calibration Point	2 mm
Recommended Measurement Distance from Surface	3 mm



Accredited by the Swiss Accreditation Service (SAS)  
The Swiss Accreditation Service is one of the signatories to the EA  
Multilateral Agreement for the recognition of calibration certificates

Accreditation No.: **SCS 108**

Client **PC Test**

Certificate No: **EX-3550\_Feb11**

**CALIBRATION CERTIFICATE**

Object: **EX3DV4 - SN:3550**

Calibration procedure(s): **QA CAL-01.v7, QA CAL-14.v3, QA CAL-23.v4, QA CAL-25.v3  
Calibration procedure for dosimetric E-field probes**

Calibration date: **February 14, 2011**

This calibration certificate documents the traceability to national standards, which realize the physical units of measurements (SI).  
The measurements and the uncertainties with confidence probability are given on the following pages and are part of the certificate.

All calibrations have been conducted in the closed laboratory facility: environment temperature (22 ± 3)°C and humidity < 70%.

Calibration Equipment used (M&TE critical for calibration)

✓  
KOK  
2/22/11

Primary Standards	ID	Cal Date (Certificate No.)	Scheduled Calibration
Power meter E4419B	GB41293874	01-Apr-10 (No. 217-01136)	Apr-11
Power sensor E4412A	MY41495277	01-Apr-10 (No. 217-01136)	Apr-11
Power sensor E4412A	MY41498087	01-Apr-10 (No. 217-01136)	Apr-11
Reference 3 dB Attenuator	SN: S5054 (3c)	30-Mar-10 (No. 217-01159)	Mar-11
Reference 20 dB Attenuator	SN: S5086 (20b)	30-Mar-10 (No. 217-01161)	Mar-11
Reference 30 dB Attenuator	SN: S5129 (30b)	30-Mar-10 (No. 217-01160)	Mar-11
Reference Probe ES3DV2	SN: 3013	29-Dec-10 (No. ES3-3013_Dec10)	Dec-11
DAE4	SN: 654	23-Apr-10 (No. DAE4-654_Apr10)	Apr-11
Secondary Standards	ID	Check Date (in house)	Scheduled Check
RF generator HP 8648C	US3642U01700	4-Aug-99 (in house check Oct-09)	In house check: Oct-11
Network Analyzer HP 8753E	US37390585	18-Oct-01 (in house check Oct-10)	In house check: Oct-11

	Name	Function	Signature
Calibrated by:	Katja Pokovic	Technical Manager	
Approved by:	Niels Kuster	Quality Manager	

Issued: February 14, 2011

This calibration certificate shall not be reproduced except in full without written approval of the laboratory.



Accredited by the Swiss Accreditation Service (SAS)

Accreditation No.: **SCS 108**

The Swiss Accreditation Service is one of the signatories to the EA Multilateral Agreement for the recognition of calibration certificates

### Glossary:

TSL	tissue simulating liquid
NORM <sub>x,y,z</sub>	sensitivity in free space
ConvF	sensitivity in TSL / NORM <sub>x,y,z</sub>
DCP	diode compression point
CF	crest factor (1/duty_cycle) of the RF signal
A, B, C	modulation dependent linearization parameters
Polarization $\omega$	$\omega$ rotation around probe axis
Polarization $\vartheta$	$\vartheta$ rotation around an axis that is in the plane normal to probe axis (at measurement center), i.e., $\vartheta = 0$ is normal to probe axis

### Calibration is Performed According to the Following Standards:

- IEEE Std 1528-2003, "IEEE Recommended Practice for Determining the Peak Spatial-Averaged Specific Absorption Rate (SAR) in the Human Head from Wireless Communications Devices: Measurement Techniques", December 2003
- IEC 62209-1, "Procedure to measure the Specific Absorption Rate (SAR) for hand-held devices used in close proximity to the ear (frequency range of 300 MHz to 3 GHz)", February 2005

### Methods Applied and Interpretation of Parameters:

- NORM<sub>x,y,z</sub>**: Assessed for E-field polarization  $\vartheta = 0$  ( $f \leq 900$  MHz in TEM-cell;  $f > 1800$  MHz: R22 waveguide). NORM<sub>x,y,z</sub> are only intermediate values, i.e., the uncertainties of NORM<sub>x,y,z</sub> does not affect the E<sup>2</sup>-field uncertainty inside TSL (see below ConvF).
- NORM(f)<sub>x,y,z</sub> = NORM<sub>x,y,z</sub> \* frequency\_response** (see Frequency Response Chart). This linearization is implemented in DASY4 software versions later than 4.2. The uncertainty of the frequency response is included in the stated uncertainty of ConvF.
- DCP<sub>x,y,z</sub>**: DCP are numerical linearization parameters assessed based on the data of power sweep with CW signal (no uncertainty required). DCP does not depend on frequency nor media.
- PAR**: PAR is the Peak to Average Ratio that is not calibrated but determined based on the signal characteristics
- A<sub>x,y,z</sub>; B<sub>x,y,z</sub>; C<sub>x,y,z</sub>** are numerical linearization parameters in dB assessed based on the data of power sweep for specific modulation signal. The parameters do not depend on frequency nor media.
- VR**: VR is the validity range of the calibration related to the average diode voltage or DAE voltage in mV.
- ConvF and Boundary Effect Parameters**: Assessed in flat phantom using E-field (or Temperature Transfer Standard for  $f \leq 800$  MHz) and inside waveguide using analytical field distributions based on power measurements for  $f > 800$  MHz. The same setups are used for assessment of the parameters applied for boundary compensation (alpha, depth) of which typical uncertainty values are given. These parameters are used in DASY4 software to improve probe accuracy close to the boundary. The sensitivity in TSL corresponds to NORM<sub>x,y,z</sub> \* ConvF whereby the uncertainty corresponds to that given for ConvF. A frequency dependent ConvF is used in DASY version 4.4 and higher which allows extending the validity from  $\pm 50$  MHz to  $\pm 100$  MHz.
- Spherical isotropy (3D deviation from isotropy)**: in a field of low gradients realized using a flat phantom exposed by a patch antenna.
- Sensor Offset**: The sensor offset corresponds to the offset of virtual measurement center from the probe tip (on probe axis). No tolerance required.

# Probe EX3DV4

## SN:3550

Manufactured: May 19, 2004  
Calibrated: February 14, 2011

Calibrated for DASY/EASY Systems  
(Note: non-compatible with DASY2 system!)

## DASY/EASY - Parameters of Probe: EX3DV4 - SN:3550

### Basic Calibration Parameters

	Sensor X	Sensor Y	Sensor Z	Unc (k=2)
Norm ( $\mu\text{V}/(\text{V}/\text{m})^2$ ) <sup>A</sup>	0.52	0.45	0.50	$\pm 10.1 \%$
DCP (mV) <sup>B</sup>	100.3	98.8	99.0	

### Modulation Calibration Parameters

UID	Communication System Name	PAR		A dB	B dB	C dB	VR mV	Unc <sup>E</sup> (k=2)
10000	CW	0.00	X	0.00	0.00	1.00	110.7	$\pm 2.2 \%$
			Y	0.00	0.00	1.00	145.7	
			Z	0.00	0.00	1.00	148.8	

The reported uncertainty of measurement is stated as the standard uncertainty of measurement multiplied by the coverage factor  $k=2$ , which for a normal distribution corresponds to a coverage probability of approximately 95%.

<sup>A</sup> The uncertainties of NormX,Y,Z do not affect the  $E^2$ -field uncertainty inside TSL (see Pages 5 and 6).

<sup>B</sup> Numerical linearization parameter: uncertainty not required.

<sup>E</sup> Uncertainty is determined using the max. deviation from linear response applying rectangular distribution and is expressed for the square of the field value.

## DASY/EASY - Parameters of Probe: EX3DV4 - SN:3550

### Calibration Parameter Determined in Head Tissue Simulating Media

f (MHz) <sup>C</sup>	Relative Permittivity <sup>F</sup>	Conductivity (S/m) <sup>F</sup>	ConvF X	ConvF Y	ConvF Z	Alpha	Depth (mm)	Unct. (k=2)
750	41.9	0.89	8.42	8.42	8.42	0.48	0.69	± 12.0 %
835	41.5	0.90	8.04	8.04	8.04	0.33	0.84	± 12.0 %
1750	40.1	1.37	7.33	7.33	7.33	0.46	0.65	± 12.0 %
1900	40.0	1.40	7.01	7.01	7.01	0.42	0.72	± 12.0 %
2450	39.2	1.80	6.29	6.29	6.29	0.13	1.57	± 12.0 %
2600	39.0	1.96	6.13	6.13	6.13	0.20	1.32	± 12.0 %
4950	36.3	4.40	4.37	4.37	4.37	0.35	1.80	± 13.1 %
5200	36.0	4.66	4.06	4.06	4.06	0.35	1.80	± 13.1 %
5300	35.9	4.76	3.92	3.92	3.92	0.35	1.80	± 13.1 %
5500	35.6	4.96	3.77	3.77	3.77	0.35	1.80	± 13.1 %
5600	35.5	5.07	3.50	3.50	3.50	0.40	1.80	± 13.1 %
5800	35.3	5.27	3.64	3.64	3.64	0.40	1.80	± 13.1 %

<sup>C</sup> Frequency validity of ± 100 MHz only applies for DASY v4.4 and higher (see Page 2), else it is restricted to ± 50 MHz. The uncertainty is the RSS of the ConvF uncertainty at calibration frequency and the uncertainty for the indicated frequency band.

<sup>F</sup> At frequencies below 3 GHz, the validity of tissue parameters ( $\epsilon$  and  $\sigma$ ) can be relaxed to ± 10% if liquid compensation formula is applied to measured SAR values. At frequencies above 3 GHz, the validity of tissue parameters ( $\epsilon$  and  $\sigma$ ) is restricted to ± 5%. The uncertainty is the RSS of the ConvF uncertainty for indicated target tissue parameters.

## DASY/EASY - Parameters of Probe: EX3DV4- SN:3550

### Calibration Parameter Determined in Body Tissue Simulating Media

f (MHz) <sup>c</sup>	Relative Permittivity <sup>f</sup>	Conductivity (S/m) <sup>f</sup>	ConvF X	ConvF Y	ConvF Z	Alpha	Depth (mm)	Unct. (k=2)
750	55.5	0.96	8.18	8.18	8.18	0.23	1.09	± 12.0 %
835	55.2	0.97	8.11	8.11	8.11	0.25	1.05	± 12.0 %
1750	53.4	1.49	7.21	7.21	7.21	0.42	0.89	± 12.0 %
1900	53.3	1.52	6.77	6.77	6.77	0.35	0.84	± 12.0 %
2450	52.7	1.95	6.25	6.25	6.25	0.30	0.86	± 12.0 %
2600	52.5	2.16	5.98	5.98	5.98	0.21	1.03	± 12.0 %
3700	51.0	3.55	5.42	5.42	5.42	0.20	1.95	± 13.1 %
4950	49.4	5.01	3.72	3.72	3.72	0.45	1.90	± 13.1 %
5200	49.0	5.30	3.58	3.58	3.58	0.45	1.90	± 13.1 %
5300	48.9	5.42	3.31	3.31	3.31	0.48	1.90	± 13.1 %
5500	48.6	5.65	3.21	3.21	3.21	0.47	1.90	± 13.1 %
5600	48.5	5.77	3.19	3.19	3.19	0.45	1.90	± 13.1 %
5800	48.2	6.00	3.29	3.29	3.29	0.50	1.90	± 13.1 %

<sup>c</sup> Frequency validity of ± 100 MHz only applies for DASY v4.4 and higher (see Page 2), else it is restricted to ± 50 MHz. The uncertainty is the RSS of the ConvF uncertainty at calibration frequency and the uncertainty for the indicated frequency band.

<sup>f</sup> At frequencies below 3 GHz, the validity of tissue parameters ( $\epsilon$  and  $\sigma$ ) can be relaxed to ± 10% if liquid compensation formula is applied to measured SAR values. At frequencies above 3 GHz, the validity of tissue parameters ( $\epsilon$  and  $\sigma$ ) is restricted to ± 5%. The uncertainty is the RSS of the ConvF uncertainty for indicated target tissue parameters.

# Frequency Response of E-Field

(TEM-Cell:ifi110 EXX, Waveguide: R22)

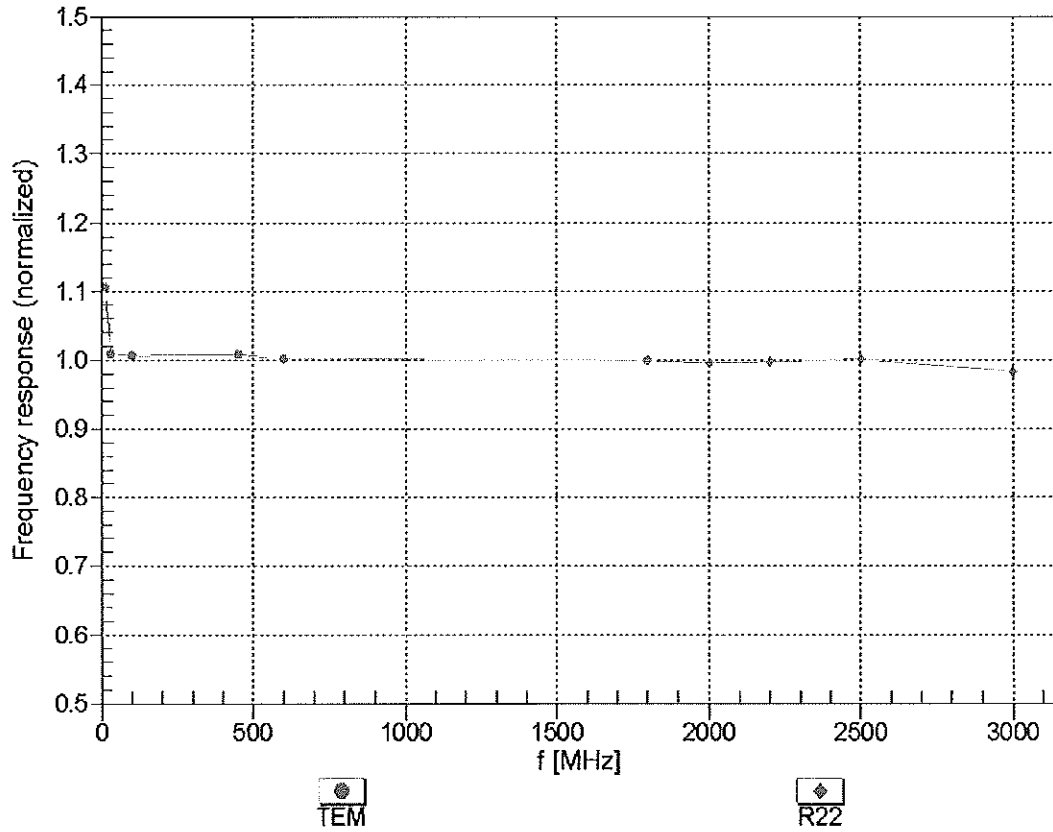

Uncertainty of Frequency Response of E-field:  $\pm 6.3\%$  (k=2)

## Receiving Pattern ( $\phi$ ), $\theta = 0^\circ$

f=600 MHz,TEM

f=1800 MHz,R22

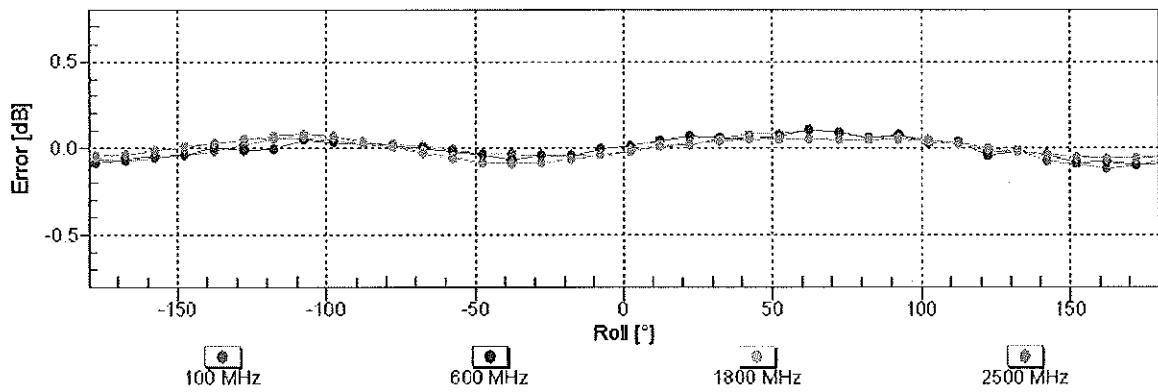
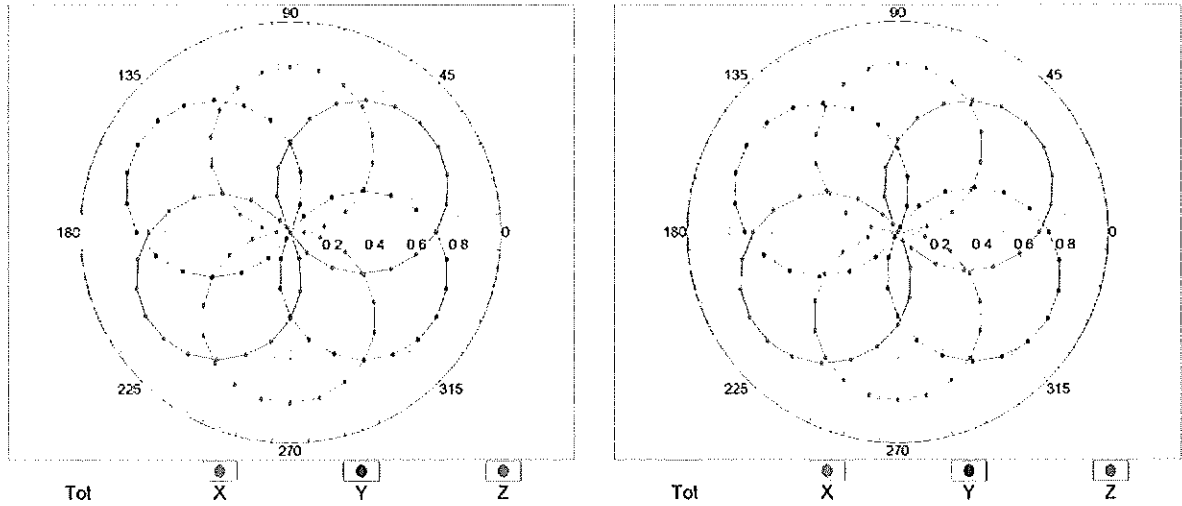

Uncertainty of Axial Isotropy Assessment:  $\pm 0.5\%$  ( $k=2$ )

## Dynamic Range $f(\text{SAR}_{\text{head}})$ (TEM cell, $f = 900 \text{ MHz}$ )

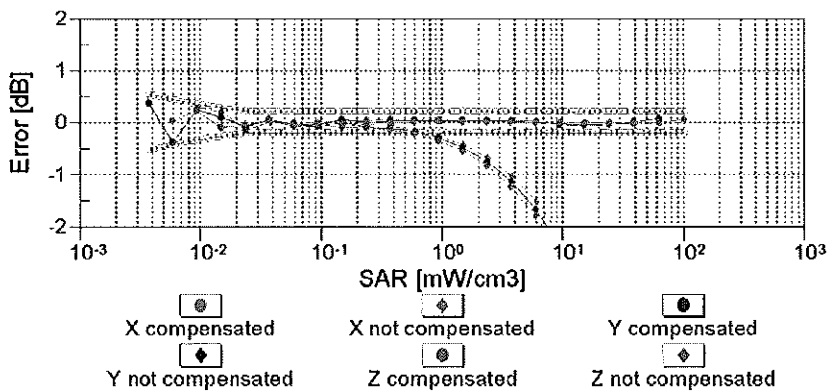
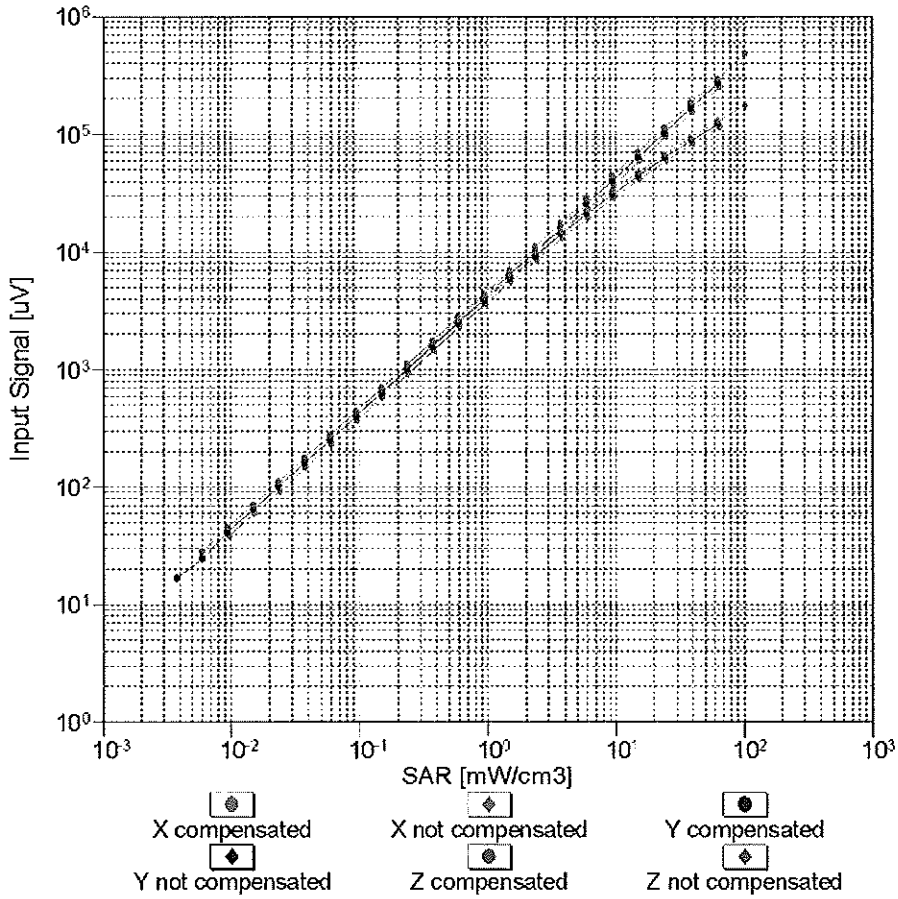

**Uncertainty of Linearity Assessment:  $\pm 0.6\%$  ( $k=2$ )**

# Conversion Factor Assessment

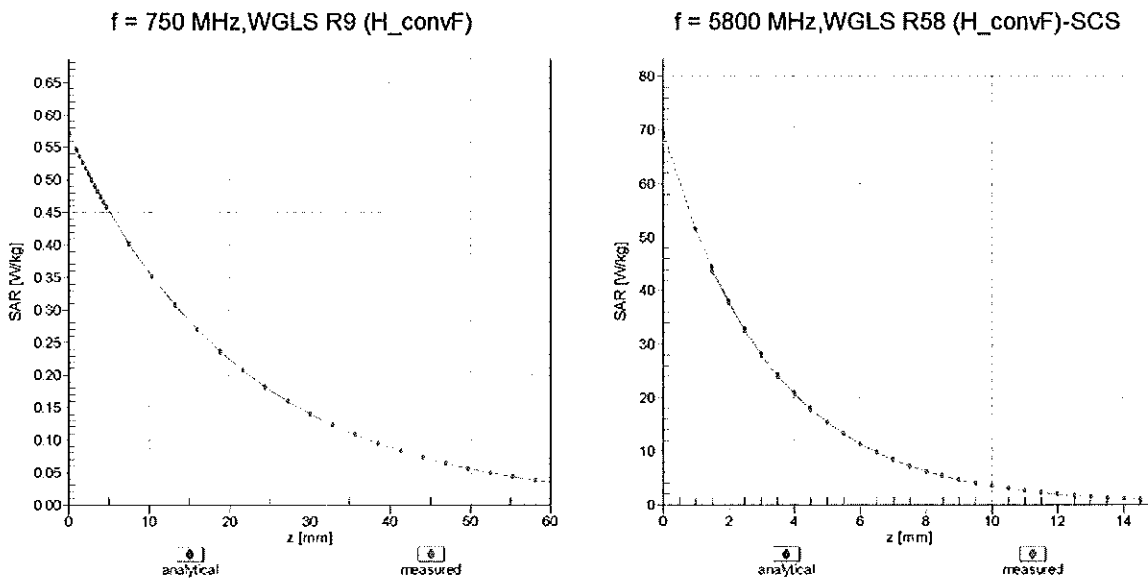

## Deviation from Isotropy in Air Error ( $\phi, \vartheta$ ), f = 900 MHz

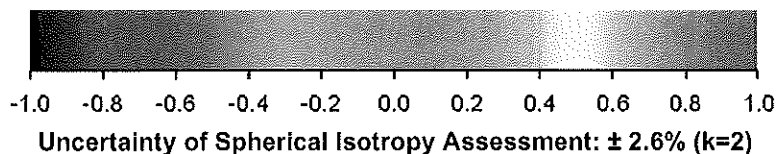
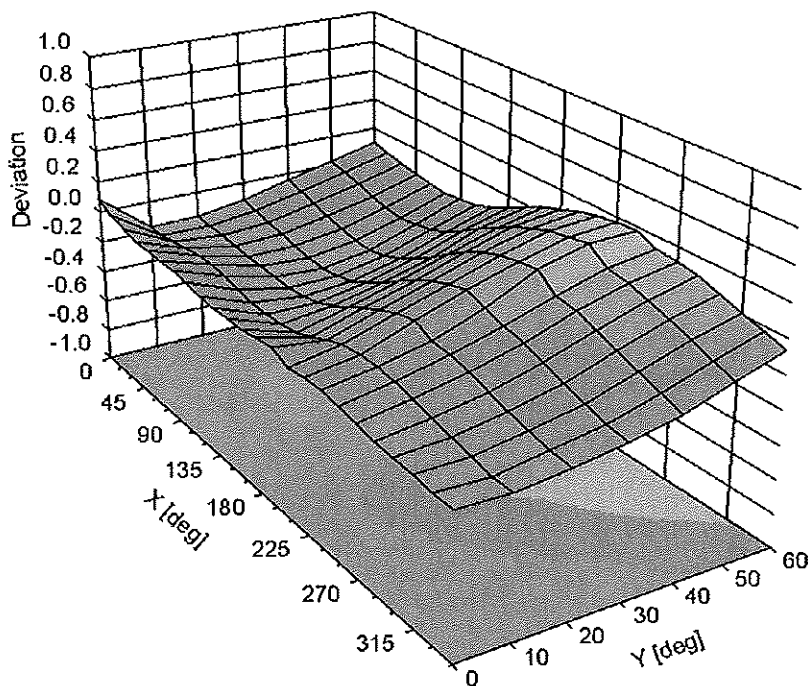

## DASY/EASY - Parameters of Probe: EX3DV4 - SN:3550

### Other Probe Parameters

Sensor Arrangement	Triangular
Connector Angle (°)	Not applicable
Mechanical Surface Detection Mode	enabled
Optical Surface Detection Mode	disabled
Probe Overall Length	337 mm
Probe Body Diameter	10 mm
Tip Length	9 mm
Tip Diameter	3 mm
Probe Tip to Sensor X Calibration Point	1 mm
Probe Tip to Sensor Y Calibration Point	1 mm
Probe Tip to Sensor Z Calibration Point	1 mm
Recommended Measurement Distance from Surface	2 mm