



SAR EVALUATION REPORT

Applicant Name:
 Samsung Electronics Co., Ltd.
 416, Maetan 3-dong, Yeongtong-gu, Suwon-si
 Gyeonggi-do, 443-742
 Republic of Korea

Date of Testing:
 05/31/12 - 06/19/12
Test Site/Location:
 PCTEST Lab, Columbia, MD, USA
Document Serial No.:
 0Y1205290731.A3L

FCC ID: A3LSCHI415

APPLICANT: SAMSUNG ELECTRONICS CO., LTD.

DUT Type: Portable Handset
Application Type: Certification
FCC Rule Part(s): CFR §2.1093
Model(s): SCH-I415

Band & Mode	Tx Frequency	Conducted Power [dBm]	SAR		
			1 gm Head (W/kg)	1 gm Body-Worn (W/kg)	1 gm Hotspot (W/kg)
Cell. CDMA/EVDO	824.70 - 848.31 MHz	24.39	0.29	0.59	0.69
PCS CDMA/EVDO	1851.25 - 1908.75 MHz	24.55	0.20	0.50	0.57
GSM/GPRS/EDGE 850	824.20 - 848.80 MHz	32.46	0.26	0.76	0.76
GSM/GPRS/EDGE 1900	1850.20 - 1909.80 MHz	30.01	0.15	0.78	0.78
LTE Band 13	782 MHz	22.89	0.08	0.23	0.23
2.4 GHz WLAN	2412 - 2462 MHz	16.45	0.07	0.12	0.12
5.8 GHz WLAN	5745 - 5825 MHz	12.81	0.08	0.00	
5.2 GHz WLAN	5180 - 5240 MHz	12.18	0.02	0.00	
5.3 GHz WLAN	5260 - 5320 MHz	12.73	0.06	0.00	
5.5 GHz WLAN	5500 - 5700 MHz	12.75	0.05	0.01	
Bluetooth	2402 - 2480 MHz	10.32	N/A		
Simultaneous SAR per KDB 690783 D01:			0.37	0.79	0.90

Note: Powers in the above table represent output powers for the SAR test configurations and may not represent the highest output powers for all configurations for each mode.



This wireless portable device has been shown to be capable of compliance for localized specific absorption rate (SAR) for uncontrolled environment/general population exposure limits specified in ANSI/IEEE C95.1-1992 and has been tested in accordance with the measurement procedures specified in FCC/OET Bulletin 65 Supplement C (2001), IEEE 1528-2003 and in applicable Industry Canada Radio Standards Specifications (RSS); for North American frequency bands only.

I attest to the accuracy of data. All measurements reported herein were performed by me or were made under my supervision and are correct to the best of my knowledge and belief. I assume full responsibility for the completeness of these measurements and vouch for the qualifications of all persons taking them. Test results reported herein relate only to the item(s) tested.

PCTEST certifies that no party to this application has been subject to a denied of the Federal benefits that includes FCC benefits pursuant to Section 5301 of the Anti-Drug Abuse Act of 1988, 21 U.S.C. 862.



 Randy Ortanez
 President



FCC ID: A3LSCHI415		SAR EVALUATION REPORT		Reviewed by: Quality Manager
Document S/N: 0Y1205290731.A3L	Test Dates: 05/31/12 - 06/19/12	DUT Type: Portable Handset	Page 1 of 61	

T A B L E O F C O N T E N T S

1	DEVICE UNDER TEST	3
2	LTE CHECKLIST PER KDB 941225 D05	8
3	INTRODUCTION	9
4	SAR MEASUREMENT SETUP	10
5	DOSIMETRIC ASSESSMENT	13
6	DEFINITION OF REFERENCE POINTS	14
7	TEST CONFIGURATION POSITIONS FOR HANDSETS	15
8	FCC RF EXPOSURE LIMITS	18
9	FCC MEASUREMENT PROCEDURES	19
10	RF CONDUCTED POWERS	22
11	LTE POWER REDUCTION	28
12	SYSTEM VERIFICATION	33
13	SAR DATA SUMMARY	36
14	FCC MULTI-TX AND ANTENNA SAR CONSIDERATIONS	48
15	EQUIPMENT LIST	56
16	MEASUREMENT UNCERTAINTIES	57
17	CONCLUSION	59
18	REFERENCES	60

FCC ID: A3LSCHI415		SAR EVALUATION REPORT		Reviewed by: Quality Manager
Document S/N: 0Y1205290731.A3L	Test Dates: 05/31/12 - 06/19/12	DUT Type: Portable Handset	Page 2 of 61	

1 DEVICE UNDER TEST

1.1 Device Overview

Band & Mode		Tx Frequency
CDMA/EVDO	Cell. CDMA/EVDO	824.70 – 848.31 MHz
	PCS CDMA/EVDO	1851.25 – 1908.75 MHz
GSM/GPRS/EDGE	GSM/GPRS/EDGE 850	824.20 – 848.80 MHz
	GSM/GPRS/EDGE 1900	1850.20 – 1909.80 MHz
LTE	LTE Band 13	782 MHz
WLAN	2.4 GHz WLAN	2412 – 2462 MHz
	5.8 GHz WLAN	5745 – 5825 MHz
	5.2 GHz WLAN	5180 – 5240 MHz
	5.3 GHz WLAN	5260 – 5320 MHz
	5.5 GHz WLAN	5500 – 5700 MHz
Bluetooth	Bluetooth	2402 – 2480 MHz
NFC	NFC	13.56 MHz

1.2 Near Field Communications (NFC) Antenna

This DUT has NFC operations. The NFC antenna is integrated into the standard battery and will be the only battery available from the manufacturer for this model. Therefore all SAR tests were performed with the standard battery which already integrates the NFC antenna. The device restricts the battery used to battery model: **EB-L1K61LZ**.

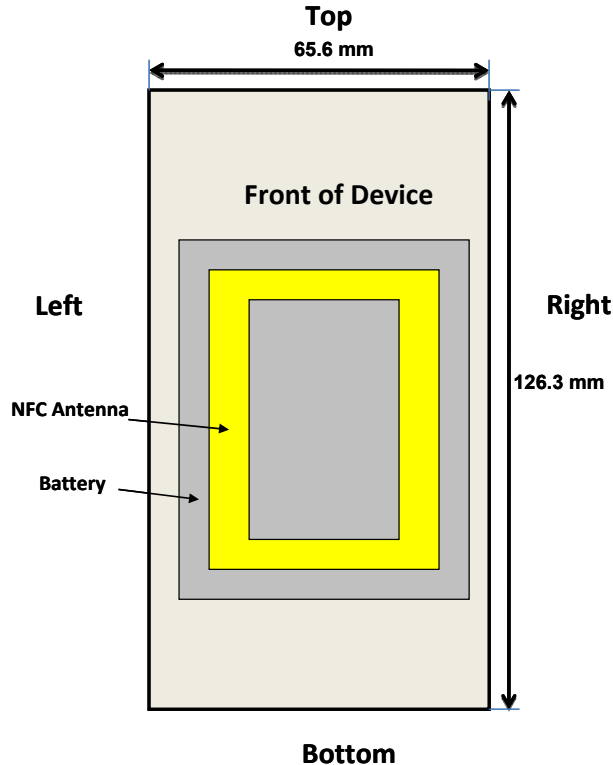

Figure 1-1
NFC Antenna Locations

FCC ID: A3LSCH1415	PCTEST ENGINEERING LABORATORY, INC.	SAR EVALUATION REPORT	SAMSUNG	Reviewed by: Quality Manager
Document S/N: 0Y1205290731.A3L	Test Dates: 05/31/12 - 06/19/12	DUT Type: Portable Handset		Page 3 of 61

1.3 DUT Antenna Locations

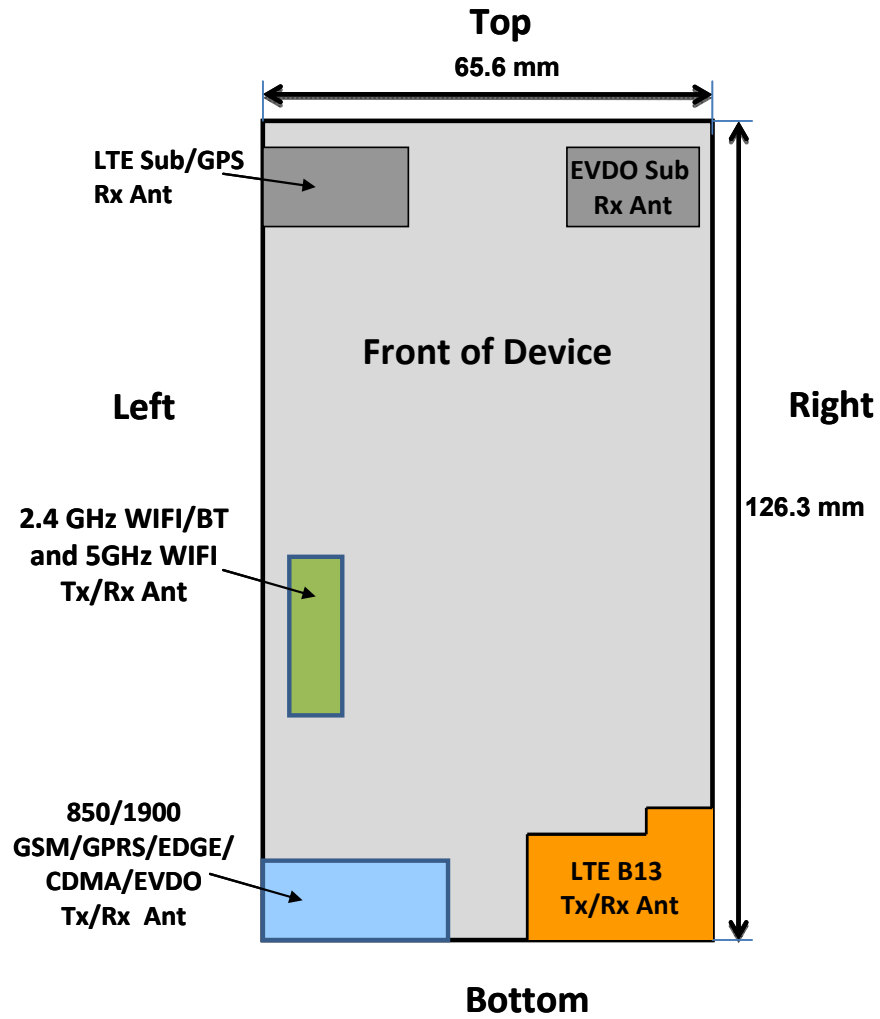



Figure 1-2
DUT Antenna Locations

FCC ID: A3LSCH1415		SAR EVALUATION REPORT		Reviewed by: Quality Manager
Document S/N: 0Y1205290731.A3L	Test Dates: 05/31/12 - 06/19/12	DUT Type: Portable Handset		Page 4 of 61

**Table 1-1
Mobile Hotspot Sides for SAR Testing**

Mobile Hotspot Sides for SAR Testing						
Mode	Back	Front	Top	Bottom	Right	Left
Cell. CDMA/EVDO	Yes	Yes	No	Yes	No	Yes
PCS CDMA/EVDO	Yes	Yes	No	Yes	No	Yes
GPRS 850	Yes	Yes	No	Yes	No	Yes
GPRS 1900	Yes	Yes	No	Yes	No	Yes
LTE Band 13	Yes	Yes	No	Yes	Yes	No
2.4 GHz WLAN	Yes	Yes	No	No	No	Yes

Note: Particular DUT edges were not required to be evaluated for Wireless Router SAR if the edges were greater than 2.5 cm from the transmitting antenna according to FCC KDB Publication 941225 D06 guidance, page 2. The antenna document shows the distances between the transmit antennas and the edges of the device. When the wireless router mode is enabled, all 5 GHz bands are disabled. Therefore 5 GHz WIFI is not considered in this section.

1.4 Power Reduction for SAR

This device uses power reduction mechanisms for LTE during SVLTE (voice + LTE data) operation for SAR compliance. See Section 11 for more details.

1.5 Simultaneous Transmission Capabilities

According to KDB 648474, transmitters are considered to be transmitting simultaneously when there is overlapping transmission, with the exception of transmissions during network hand-offs with maximum hand-off duration less than 30 seconds. Possible transmission paths for the DUT are shown in Figure 1-3 and are color-coded to indicate communication modes which share the same path. Modes which share the same transmission path cannot transmit simultaneously with one another.



**Figure 1-3
Simultaneous Transmission Paths**

This device contains multiple transmitters that may operate simultaneously, and therefore requires a simultaneous transmission analysis according to KDB 447498 3) procedures.

FCC ID: A3LSCHI415		SAR EVALUATION REPORT		Reviewed by: Quality Manager
Document S/N: 0Y1205290731.A3L	Test Dates: 05/31/12 - 06/19/12	DUT Type: Portable Handset		Page 5 of 61

**Table 1-2
Simultaneous Transmission Scenarios**



Ref.	Simultaneous Transmit Configurations	Power Reduction	SAR Report Section	Head	Body-Worn Accessory	Hot Spot	Note
				IEEE 1528, Supp C	Supplement C	FCC KDB 941225 D06 edges/sides	
A	1X CDMA 850 Voice + LTE 782 MHz Data	LTE	Section 14.6	Yes	10mm	-	SVLTE
B	1X CDMA 1900 Voice + LTE 782 MHz Data			Yes	10mm	-	SVLTE
C	1X CDMA 850 Voice + 2.4 GHz WIFI	-	Section 14.4	Yes	10mm	-	
D	1X CDMA 850 Voice + 5 GHz WIFI			Yes	10mm	-	
E	1X CDMA 1900 Voice + 2.4 GHz WIFI			Yes	10mm	-	
F	1X CDMA 1900 Voice + 5 GHz WIFI			Yes	10mm	-	
G	GSM850 Voice + 2.4 GHz WIFI			Yes	10mm	-	
H	GSM850 Voice + 5 GHz WIFI			Yes	10mm	-	
I	GSM1900 Voice + 2.4 GHz WIFI			Yes	10mm	-	
J	GSM1900 Voice + 5 GHz WIFI	Yes	10mm	-			
K	1X CDMA 850 Voice + LTE 782 MHz Data + 2.4 GHz WIFI	LTE	Section 14.6	Yes	10mm	Yes	Voice + LTE + WIFI Hotspot
L	1X CDMA 1900 Voice + LTE 782 MHz Data + 2.4 GHz WIFI			Yes	10mm	Yes	Voice + LTE + WIFI Hotspot
M	1X CDMA 850 Data + 2.4 GHz WIFI	-	Section 14.5	-	-	Yes	1X CDMA Data +WIFI Hotspot
N	1X CDMA 1900 Data + 2.4 GHz WIFI			-	-	Yes	1X CDMA Data +WIFI Hotspot
O	EVDO 850 Data + 2.4 GHz WIFI			-	-	Yes	EVDO+WIFI Hotspot
P	EVDO 1900 Data + 2.4 GHz WIFI			-	-	Yes	EVDO+WIFI Hotspot
Q	LTE 782 MHz Data + 2.4 GHz WIFI			-	-	Yes	LTE+WIFI Hotspot
R	GPRS/EDGE 850 Data + 2.4 GHz WIFI			-	-	Yes	GPRS/EDGE + WIFI Hotspot
S	GPRS/EDGE 1900 Data + 2.4 GHz WIFI			-	-	Yes	GPRS/EDGE + WIFI Hotspot
	1x CDMA 850 Voice + EVDO 850 Data	-	-	-	-	-	Not Supported by HW
	1x CDMA 850 Voice + EVDO 1900 Data	-	-	-	-	-	Not Supported by HW
	1x CDMA 1900 Voice + EVDO 850 Data	-	-	-	-	-	Not Supported by HW
	1x CDMA 1900 Voice + EVDO 1900 Data	-	-	-	-	-	Not Supported by HW
	1x CDMA 850 Voice + EVDO 850 Data + 2.4 GHz WIFI	-	-	-	-	-	Not Supported by HW (Voice + EVDO + WIFI Hotspot)
	1x CDMA 850 Voice + EVDO 1900 Data + 2.4 GHz WIFI	-	-	-	-	-	Not Supported by HW (Voice + EVDO + WIFI Hotspot)
	1x CDMA 1900 Voice + EVDO 850 Data + 2.4 GHz WIFI	-	-	-	-	-	Not Supported by HW (Voice + EVDO + WIFI Hotspot)
	1x CDMA 1900 Voice + EVDO 1900 Data + 2.4 GHz WIFI	-	-	-	-	-	Not Supported by HW (Voice + EVDO + WIFI Hotspot)
	GSM 850/1900 Voice + 850/1900 1X-RTT CDMA Data	-	-	-	-	-	Not Supported by HW
	GSM 850/1900 Voice + EVDO/GPRS/EDGE Data	-	-	-	-	-	Not Supported by HW
	GSM 850/1900 Voice + LTE	-	-	-	-	-	Not Supported by SW
	GSM 850/1900 Voice + 850/1900 1X-RTT CDMA + 2.4/5 GHz WIFI	-	-	-	-	-	Not Supported by HW
	GSM 850/1900 Voice + EVDO/GPRS/EDGE + 2.4/5 GHz WIFI	-	-	-	-	-	Not supported by HW
	GSM 850/1900 Voice + LTE + 2.4/5 GHz WIFI	-	-	-	-	-	Not Supported by SW
	1X CDMA 850 Voice + LTE 782 MHz Data + 5 GHz WIFI	-	-	-	-	-	Not Supported by SW
	1X CDMA 1900 Voice + LTE 782 MHz Data + 5 GHz WIFI	-	-	-	-	-	Not Supported by SW
	GPRS/EDGE 850/1900 Data + 5 GHz WIFI	-	-	-	-	-	Not Supported by SW
	LTE 782MHz Data + 5 GHz WIFI	-	-	-	-	-	Not Supported by SW
	1X 850/1900 Data + 5 GHz WIFI	-	-	-	-	-	Not Supported by SW
	EVDO 850/1900 Data + 5 GHz WIFI	-	-	-	-	-	Not Supported by SW
	850/1900 GPRS/EDGE Data + LTE 782 MHz Data	-	-	-	-	-	Not supported by SW
	850/1900 EVDO Data + 850/1900 GPRS/EDGE Data	-	-	-	-	-	Not supported by HW
	850/1900 EVDO data + LTE 782 MHz Data	-	-	-	-	-	Not supported by SW

1.6 SAR Test Exclusions Applied

(A) WIFI/BT

Since Wireless Router operations are not allowed by the chipset firmware using 5 GHz WIFI, only 2.4 GHz WIFI Hotspot SAR tests and combinations are considered for SAR with respect to Wireless Router configurations in KDB 941225 D06.

The separation between the CDMA/EVDO/GSM/GPRS/EDGE antenna and the Bluetooth/WLAN antennas is 18.2 mm. The separation between the LTE antenna and the Bluetooth/WLAN antenna is 42.7 mm.

FCC ID: A3LSCH1415		SAR EVALUATION REPORT		Reviewed by: Quality Manager
Document S/N: 0Y1205290731.A3L	Test Dates: 05/31/12 - 06/19/12	DUT Type: Portable Handset		Page 6 of 61

RF Conducted Power of Bluetooth Tx is 10.765 mW (Please refer to the EMC DSS Report for a full set of Bluetooth conducted powers).

2.4 GHz and 5 GHz WIFI and Bluetooth share the same antenna path and cannot transmit simultaneously.

Per KDB Publication 648474, **Bluetooth SAR was not required** based on the maximum conducted power, the Bluetooth/WLAN to main antenna separation distance and Body-SAR of the main antenna.

This device supports 20MHz and 40MHz Bandwidths for IEEE 802.11n for 5 GHz WIFI only. 802.11n was not evaluated for SAR since the average output power of 20 MHz and 40 MHz bandwidths was not more than 0.25 dB higher than the average output power of 802.11a.

(B) Licensed Transmitter(s)

GSM/GPRS/EDGE DTM is not supported. Therefore GSM Voice cannot transmit simultaneously with GPRS/EDGE Data.

Simultaneous Voice and EVDO data (“SVDO”) cannot transmit simultaneously since they utilize the same transmission path as illustrated in **Figure 1-3**.



1.7 Guidance Applied

- FCC OET Bulletin 65 Supplement C [June 2001]
- IEEE 1528-2003
- FCC KDB 941225 (2G/3G/4G and Hotspot)
- FCC KDB 248227 (802.11)
- FCC KDB 648474 (Simultaneous)
- FCC KDB 865664 (5 GHz)



1.8 Samples Used for SAR Testing

Several samples were used with identical hardware. Reduced power levels were configured by the manufacturer via software to support SAR test cases.

Mode/Band:	Cell. CDMA/EVDO		PCS CDMA/EVDO		GSM850	GSM1900
Target Power (dBm):	24.5	18	24.5	18	32	30
Serial Number:	0841-1297	0841-1300	0841-1297	0841-1300	0841-1295	0841-1299
Mode/Band:	LTE					
Target Power (dBm):	23	19				
Serial Number:	0841-1298	0841-1300				
Mode/Band:	2.4 + 5 GHz WIFI					
Serial Number:	0841-1295					

FCC ID: A3LSCHI415	 PCTEST ENGINEERING LABORATORY, INC.	SAR EVALUATION REPORT		Reviewed by: Quality Manager
Document S/N: 0Y1205290731.A3L	Test Dates: 05/31/12 - 06/19/12	DUT Type: Portable Handset	Page 7 of 61	

KDB 941225 Pub LTE Information			
KDB 941225 Sec.	FCC ID:	A3LSCHI415	
	Form Factor	Portable Handset	
1)	Frequency Range of each LTE transmission band	BAND 13: 782 MHz	
2)	Channel Bandwidths (MHz)	Band 13: 10 MHz	
3)	Channel Numbers and Frequencies (MHz)	Low	Mid
	LTE Band 2 and BW 5MHz		782 MHz (23230)
4)(a)	UE Category	3	
(b)	Modulations Supported in UL	QPSK, 16QAM	
	LTE Transmitter and Antenna Implementation	LTE and CDMA/EVDO/GSM operate on separate antenna paths.	
5)	Description of LTE Tx and Ant. Implementation	1 Tx/Rx Ant, 1 Rx Ant only	
6)	LTE Voice available	NO	
	Hotspot with LTE+WIFI	Yes	
	Hotspot with LTE+WIFI with Voice	Yes	
7)	LTE MPR Permanently implemented per 3GPP TS 36.101 section 6.2.3~6.2.5? (manufacturer attestatin to be provided)	YES	
	A-MPR (Additional MPR) disabled for SAR Testing?	YES	
8)	Conducted power Table provided for 1RB (low and high offset), 50% RB (centered), 100% RB	YES	
9-10)	Non-LTE US Wireless Operating Modes/Bands	RF Output Power	RF Exposure Configurations
	Cell. CDMA/EVDO	See Page 1	
	PCS CDMA/EVDO		
	850 MHz GSM/GPRS/EDGE		
	1900 MHz GSM/GPRS/EDGE		
	2.4 GHz Bluetooth		
	2.4 GHz WI-FI		
5 GHz Wi-Fi			
11)	Simultaneous Tx Conditions (Voice and Data Configurations)	See Section 1.5	
12)	Power Reduction used for SAR Compliance?	Yes	
13)	Describe Power Reduction (LTE Modes)	See Section 11	
14)	SAR Test Plan	See Section 11	
15)	SAR test data, preliminary	See Section 13	

FCC ID: A3LSCHI415		SAR EVALUATION REPORT		Reviewed by: Quality Manager
Document S/N: 0Y1205290731.A3L	Test Dates: 05/31/12 - 06/19/12	DUT Type: Portable Handset	Page 8 of 61	

3 INTRODUCTION

The FCC has adopted the guidelines for evaluating the environmental effects of radio frequency (RF) radiation in ET Docket 93-62 on Aug. 6, 1996 to protect the public and workers from the potential hazards of RF emissions due to FCC-regulated portable devices. [1]

The safety limits used for the environmental evaluation measurements are based on the criteria published by the American National Standards Institute (ANSI) for localized specific absorption rate (SAR) in IEEE/ANSI C95.1-1992 Standard for Safety Levels with Respect to Human Exposure to Radio Frequency Electromagnetic Fields, 3 kHz to 300 GHz [3] and Health Canada RF Exposure Guidelines Safety Code 6 [24]. The measurement procedure described in IEEE/ANSI C95.3-2002 Recommended Practice for the Measurement of Potentially Hazardous Electromagnetic Fields - RF and Microwave [4] is used for guidance in measuring the Specific Absorption Rate (SAR) due to the RF radiation exposure from the Equipment Under Test (EUT). These criteria for SAR evaluation are similar to those recommended by the International Committee for Non-Ionizing Radiation Protection (ICNIRP) in Biological Effects and Exposure Criteria for Radiofrequency Electromagnetic Fields," Report No. Vol 74. SAR is a measure of the rate of energy absorption due to exposure to an RF transmitting source. SAR values have been related to threshold levels for potential biological hazards.

3.1 SAR Definition

Specific Absorption Rate is defined as the time derivative (rate) of the incremental energy (dU) absorbed by (dissipated in) an incremental mass (dm) contained in a volume element (dV) of a given density (ρ). It is also defined as the rate of RF energy absorption per unit mass at a point in an absorbing body (see Equation 3-1).

Equation 3-1
SAR Mathematical Equation

$$SAR = \frac{d}{dt} \left(\frac{dU}{dm} \right) = \frac{d}{dt} \left(\frac{dU}{\rho dV} \right)$$



SAR is expressed in units of Watts per Kilogram (W/kg).

$$SAR = \frac{\sigma \cdot E^2}{\rho}$$

where:

- σ = conductivity of the tissue-simulating material (S/m)
- ρ = mass density of the tissue-simulating material (kg/m^3)
- E = Total RMS electric field strength (V/m)

NOTE: The primary factors that control rate of energy absorption were found to be the wavelength of the incident field in relation to the dimensions and geometry of the irradiated organism, the orientation of the organism in relation to the polarity of field vectors, the presence of reflecting surfaces, and whether conductive contact is made by the organism with a ground plane.[6]

FCC ID: A3LSCHI415	 PCTEST ENGINEERING LABORATORY, INC.	SAR EVALUATION REPORT		Reviewed by: Quality Manager
Document S/N: 0Y1205290731.A3L	Test Dates: 05/31/12 - 06/19/12	DUT Type: Portable Handset		Page 9 of 61

4 SAR MEASUREMENT SETUP

4.1 Automated SAR Measurement System

Measurements are performed using the DASY automated dosimetric SAR assessment system. The DASY is made by Schmid & Partner Engineering AG (SPEAG) in Zurich, Switzerland and consists of a high precision robotics system (Staubli), robot controller, desktop computer, near-field probe, probe alignment sensor, and the SAM phantom containing the head or body equivalent material. The robot is a six-axis industrial robot, performing precise movements to position the probe to the location (points) of maximum electromagnetic field (EMF). See www.speag.com for more information about the specification of the SAR assessment system.



Figure 4-1
SAR Measurement System





Figure 4-2
Near-Field Probe

Table 4-1
Composition of the Tissue Equivalent Matter

Frequency (MHz)	835	835	1900	1900	2450	2450	5200-5800	5200-5800
Tissue	Head	Body	Head	Body	Head	Body	Head	Body
Ingredients (% by weight)								
Bactericide	0.1	0.1						
DGBE			44.92	29.44	7.99	26.7		
HEC	1	1						
NaCl	1.45	0.94	0.18	0.39	0.16	0.1		
Sucrose	57	44.9						
Triton X-100					19.97		17.24	
Diethylenglycol monohexylether							17.24	
Polysorbate (Tween) 80								20
Water	40.45	53.06	54.9	70.17	71.88	73.2	65.52	80

See next page for 750 MHz Tissue Composition

FCC ID: A3LSCHI415		SAR EVALUATION REPORT		Reviewed by: Quality Manager
Document S/N: 0Y1205290731.A3L	Test Dates: 05/31/12 - 06/19/12	DUT Type: Portable Handset		Page 10 of 61

**Table 4-2
Composition of 750 MHz Head and Body Tissue Equivalent Matter**

2 Composition / Information on ingredients	
The Item is composed of the following ingredients:	
H ₂ O	Water, 35 – 58%
Sucrose	Sugar, white, refined, 40 – 60%
NaCl	Sodium Chloride, 0 – 6%
Hydroxyethyl-cellulose	Medium Viscosity (CAS# 9004-82-0), <0.3%
Preventol-D7	Preservative: aqueous preparation, (CAS# 55965-84-9), containing 5-chloro-2-methyl-3(2H)-isothiazolone and 2-methyl-3(2H)-isothiazolone, 0.1 – 0.7%
Relevant for safety: Refer to the respective Safety Data Sheet*.	

Note: 750MHz liquid recipes are proprietary SPEAG. Since the composition is approximate to the actual liquids utilized, the manufacturer tissue-equivalent liquid data sheets are provided below.

Measurement Certificate / Material Test

Item Name	Body Tissue Simulating Liquid (MSL 750)
Product No.	SL AAM 075 AA (Charge: 110606-1)
Manufacturer	SPEAG

Measurement Method

TSL dielectric parameters measured using calibrated OCP probe (type DAK).

Target Parameters

Target parameters as defined in the IEEE 1528 and IEC 62209 compliance standards.

Test Condition

Ambient Condition 22°C ; 30% humidity
TSL Temperature 22°C
Test Date 8-Jun-11

Additional Information

TSL Density 1.212 g/cm³
TSL Heat-capacity 3.006 kJ/(kg*K)

Results

f (MHz)	Measured			Target		Diff. to Target [%]	
	HP-e'	HP-e''	sigma	eps	sigma	Δ-eps	Δ-sigma
600	57.4	24.88	0.83	56.1	0.95	2.4	-12.7
625	57.2	24.53	0.85	56.0	0.95	2.1	-10.6
650	57.0	24.18	0.87	55.9	0.96	1.8	-8.5
675	56.7	23.90	0.90	55.8	0.96	1.5	-6.3
700	56.4	23.61	0.92	55.7	0.96	1.2	-4.2
725	56.2	23.37	0.94	55.6	0.96	0.9	-2.0
750	55.9	23.12	0.96	55.5	0.96	0.7	0.1
775	55.7	22.95	0.99	55.4	0.97	0.4	2.5
800	55.4	22.78	1.01	55.3	0.97	0.1	4.8
825	55.2	22.61	1.04	55.2	0.98	-0.2	6.1
838	55.0	22.52	1.05	55.2	0.98	-0.3	6.7
850	54.9	22.44	1.06	55.2	0.99	-0.4	7.3
875	54.7	22.30	1.09	55.1	1.02	-0.7	6.5
900	54.5	22.17	1.11	55.0	1.05	-1.0	5.7
925	54.2	22.05	1.13	55.0	1.06	-1.3	6.8
950	54.0	21.94	1.16	54.9	1.08	-1.7	7.8
975	53.8	21.85	1.19	54.9	1.09	-2.0	9.0
1000	53.6	21.75	1.21	54.8	1.10	-2.3	10.2

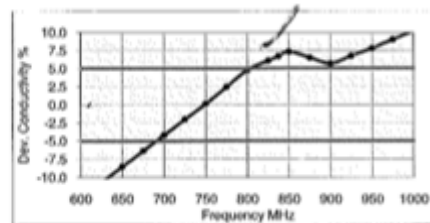
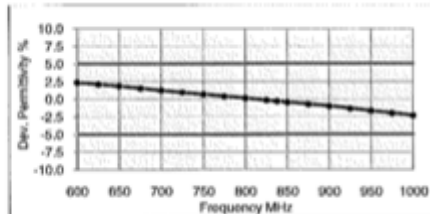

**Figure 4-3
750MHz Body Tissue Equivalent Matter**

FCC ID: A3LSCH1415	PCTEST Engineering Laboratory, Inc.	SAR EVALUATION REPORT	SAMSUNG	Reviewed by: Quality Manager
Document S/N: 0Y1205290731.A3L	Test Dates: 05/31/12 - 06/19/12	DUT Type: Portable Handset		Page 11 of 61

Measurement Certificate / Material Test

Item Name **Head Tissue Simulating Liquid (HSL 750)**
 Product No. SL AAH 075 (Charge: 110601-1)
 Manufacturer SPEAG

Measurement Method
 TSL dielectric parameters measured using calibrated OCP probe (type DAK).

Target Parameters
 Target parameters as defined in the IEEE 1528 and IEC 62209 compliance standards.

Test Condition
 Ambient Condition 22°C ; 30% humidity
 TSL Temperature 22°C
 Test Date 8-Jun-11

Additional Information
 TSL Density 1.284 g/cm³
 TSL Heat-capacity 2.701 kJ/(kg*K)

Results

f (MHz)	Measured			Target		Diff.to Target [%]	
	HP-e'	HP-e''	sigma	eps	sigma	Δ-eps	Δ-sigma
600	43.9	23.01	0.77	42.7	0.88	2.7	-12.9
625	43.5	22.75	0.79	42.6	0.88	2.1	-10.5
650	43.1	22.49	0.81	42.5	0.89	1.5	-8.2
675	42.7	22.26	0.84	42.3	0.89	1.0	-5.9
700	42.4	22.03	0.86	42.2	0.89	0.4	-3.5
725	42.0	21.84	0.88	42.1	0.89	-0.1	-1.2
750	41.7	21.65	0.90	41.9	0.89	-0.6	1.1
775	41.4	21.50	0.93	41.8	0.90	-1.1	3.5
800	41.0	21.34	0.95	41.7	0.90	-1.6	5.9
825	40.7	21.19	0.97	41.6	0.91	-2.1	7.3
838	40.5	21.12	0.98	41.5	0.91	-2.4	8.0
850	40.4	21.05	1.00	41.5	0.92	-2.7	8.6
875	40.1	20.91	1.02	41.5	0.94	-3.3	7.9
900	39.8	20.77	1.04	41.5	0.97	-4.0	7.2
925	39.6	20.66	1.06	41.5	0.98	-4.6	6.2
950	39.3	20.55	1.08	41.4	0.99	-5.2	9.2
975	39.0	20.44	1.11	41.4	1.00	-5.8	10.3
1000	38.7	20.32	1.13	41.3	1.01	-6.4	11.4

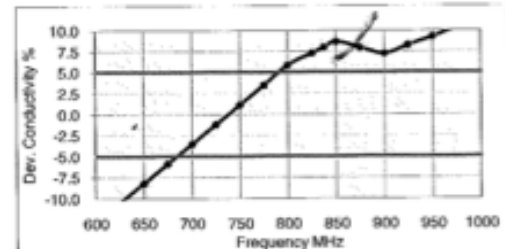
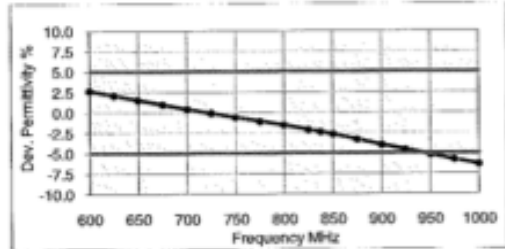

Figure 4-4
750MHz Head Tissue Equivalent Matter

FCC ID: A3LSCH1415	PCTEST Engineering Laboratory, Inc.	SAR EVALUATION REPORT		Reviewed by: Quality Manager
Document S/N: 0Y1205290731.A3L	Test Dates: 05/31/12 - 06/19/12	DUT Type: Portable Handset		Page 12 of 61

5 DOSIMETRIC ASSESSMENT

5.1 Measurement Procedure

The evaluation was performed using the following procedure:

1. The SAR distribution at the exposed side of the head or body was measured at a distance no greater than 5.0 mm from the inner surface of the shell. The area covered the entire dimension of the device-head interface and the horizontal grid resolution was 15mm and 15mm for frequencies < 3 GHz in the x and y directions respectively. When applicable, for frequencies above 3 GHz, a 10 mm by 10 mm resolution was used.
2. The point SAR measurement was taken at the maximum SAR region determined from Step 1 to enable the monitoring of SAR fluctuations/drifts during the 1 gram cube evaluation. SAR at this fixed point was measured and used as a reference value.
3. Based on the area scan data, the peak area of the maximum absorption was determined by spline interpolation. Around this point, a volume of 32mm x 32mm x 30mm (fine resolution volume scan, zoom scan) was assessed by measuring at least 5 x 5 x 7 points. On this basis of this data set, the spatial peak SAR value was evaluated with the following procedure (see references or the DASY manual online for more details):
 - a. The data was extrapolated to the surface of the outer-shell of the phantom. The combined distance extrapolated was the combined distance from the center of the dipoles 2.7mm away from the tip of the probe housing plus the 1.2 mm distance between the surface and the lowest measuring point. The extrapolation was based on a least-squares algorithm. A polynomial of the fourth order was calculated through the points in the z-axis (normal to the phantom shell).
 - b. After the maximum interpolated values were calculated between the points in the cube, the SAR was averaged over the spatial volume (1g or 10g) using a 3D-Spline interpolation algorithm. The 3D-spline is composed of three one-dimensional splines with the “Not a knot” condition (in x, y, and z directions). The volume was then integrated with the trapezoidal algorithm. One thousand points (10 x 10 x 10) were obtained through interpolation, in order to calculate the averaged SAR.
 - c. All neighboring volumes were evaluated until no neighboring volume with a higher average value was found.
4. The SAR reference value, at the same location as step 2, was re-measured after the zoom scan was complete to calculate the SAR drift. If the drift deviated by more than 5%, the SAR test and drift measurements were repeated.
5. For testing 5 GHz devices, finer resolution zoom scans were performed as specified by FCC SAR Measurement Requirements for 3 – 6 GHz, KDB 865664 publication. The 5 GHz zoom scan requires a minimum volume of 24mm x 24mm x 20mm and 7 x 7 x 11 points.

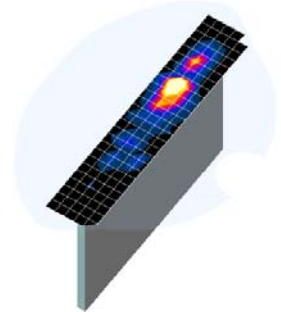



Figure 5-1
Sample SAR Area Scan

FCC ID: A3LSCHI415		SAR EVALUATION REPORT		Reviewed by: Quality Manager
Document S/N: 0Y1205290731.A3L	Test Dates: 05/31/12 - 06/19/12	DUT Type: Portable Handset		Page 13 of 61

6

DEFINITION OF REFERENCE POINTS

6.1 EAR REFERENCE POINT

Figure 6-2 shows the front, back and side views of the SAM Twin Phantom. The point “M” is the reference point for the center of the mouth, “LE” is the left ear reference point (ERP), and “RE” is the right ERP. The ERP is 15mm posterior to the entrance to the ear canal (EEC) along the B-M line (Back-Mouth), as shown in Figure 6-1. The plane passing through the two ear canals and M is defined as the Reference Plane. The line N-F (Neck-Front) is perpendicular to the reference plane and passing through the RE (or LE) is called the Reference Pivoting Line (see Figure 6-2). Line B-M is perpendicular to the N-F line. Both N-F and B-M lines are marked on the external phantom shell to facilitate handset positioning [5].

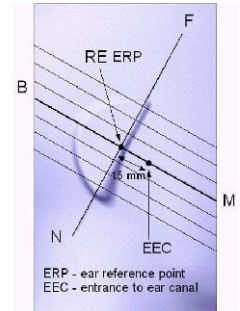

Figure 6-1
Close-Up Side view
of ERP

6.2 HANDSET REFERENCE POINTS

Two imaginary lines on the handset were established: the vertical centerline and the horizontal line. The test device was placed in a normal operating position with the “test device reference point” located along the “vertical centerline” on the front of the device aligned to the “ear reference point” (See Figure 6-3). The “test device reference point” was then located at the same level as the center of the ear reference point. The test device was positioned so that the “vertical centerline” was bisecting the front surface of the handset at its top and bottom edges, positioning the “ear reference point” on the outer surface of the both the left and right head phantoms on the ear reference point.



Figure 6-2
Front, back and side view of SAM Twin Phantom

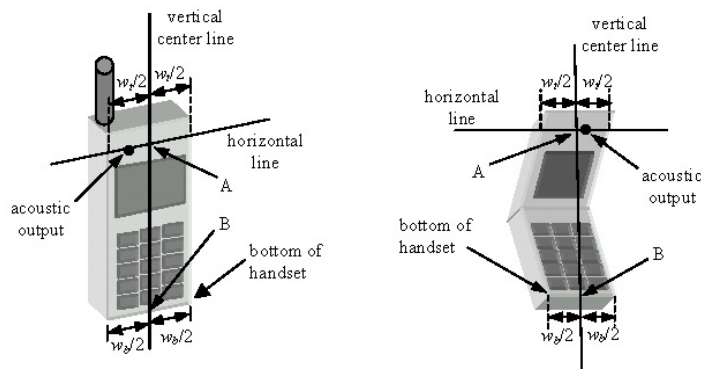



Figure 6-3
Handset Vertical Center & Horizontal Line Reference Points

FCC ID: A3LSCH1415	 PCTEST ENGINEERING LABORATORY, INC.	SAR EVALUATION REPORT		Reviewed by: Quality Manager
Document S/N: 0Y1205290731.A3L	Test Dates: 05/31/12 - 06/19/12	DUT Type: Portable Handset		Page 14 of 61

7 TEST CONFIGURATION POSITIONS FOR HANDSETS

7.1 Device Holder

The DASY device holder has been made out of low-loss POM material having the following dielectric parameters: relative permittivity $\epsilon = 3$ and loss tangent $\delta = 0.02$.

7.2 Positioning for Cheek/Touch

1. The test device was positioned with the handset close to the surface of the phantom such that point A is on the (virtual) extension of the line passing through points RE and LE on the phantom (see Figure 7-1), such that the plane defined by the vertical center line and the horizontal line of the phone is approximately parallel to the sagittal plane of the phantom.

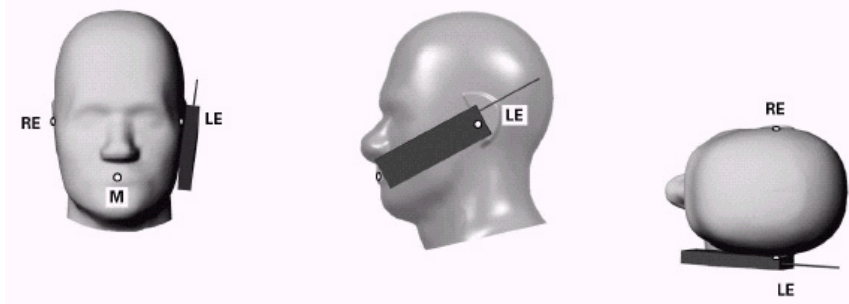



Figure 7-1 Front, Side and Top View of Cheek/Touch Position

2. The handset was translated towards the phantom along the line passing through RE & LE until the handset touches the ear.
3. While maintaining the handset in this plane, the handset was rotated around the LE-RE line until the vertical centerline was in the plane normal to MB-NF including the line MB (reference plane).
4. The phone was then rotated around the vertical centerline until the phone (horizontal line) was symmetrical with respect to the line NF.
5. While maintaining the vertical centerline in the reference plane, keeping point A on the line passing through RE and LE, and maintaining the phone contact with the ear, the handset was rotated about the line NF until any point on the handset made contact with a phantom point below the ear (cheek) (See Figure 7-2).

7.3 Positioning for Ear / 15° Tilt

With the test device aligned in the “Cheek/Touch Position”:

1. While maintaining the orientation of the phone, the phone was retracted parallel to the reference plane far enough to enable a rotation of the phone by 15degree.
2. The phone was then rotated around the horizontal line by 15 degree.
3. While maintaining the orientation of the phone, the phone was moved parallel to the reference plane until any part of the phone touches the head. (In this position, point A was located on the line RE-LE). The tilted position is obtained when the contact is on the pinna. If the contact was at any location other than the pinna, the angle of the phone would then be reduced. The tilted position was obtained when any part of the phone was in contact of the ear as well as a second part of the phone was in contact with the head (see Figure 7-2).

FCC ID: A3LSCHI415		SAR EVALUATION REPORT		Reviewed by: Quality Manager
Document S/N: 0Y1205290731.A3L	Test Dates: 05/31/12 - 06/19/12	DUT Type: Portable Handset		Page 15 of 61

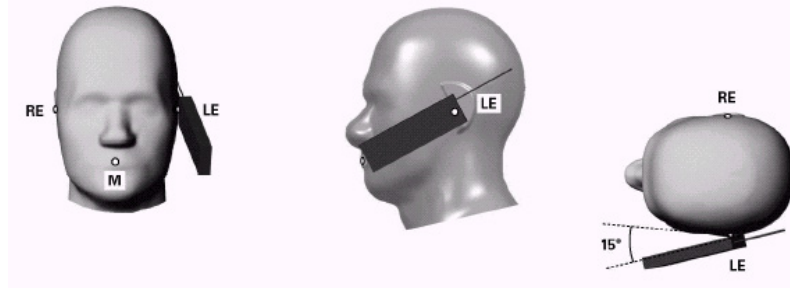

Figure 7-2 Front, Side and Top View of Ear/15° Tilt Position

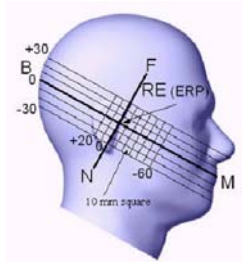

Figure 7-3 Side view w/ relevant markings



Figure 7-4 Body SAR Sample Photo (Not Actual EUT)

7.4 SAR Evaluations near the Mouth/Jaw Regions of the SAM Phantom

Antennas located near the bottom of a phone may require SAR measurements around the mouth and jaw regions of the SAM head phantom. This typically applies to clam-shell style phones that are generally longer in the unfolded normal use positions or to certain older style long rectangular phones.

Under these circumstances, the following procedures apply, adopted from the FCC guidance on SAR handsets document publication 648474. The SAR required in these regions of SAM should be measured using a flat phantom. **Rectangular shaped phones** should be positioned with its bottom edge positioned from the flat phantom with the same distance provided by the cheek touching position using SAM. The ear reference point (ERP, as defined for SAM) of the phone should be positioned ½ cm from the flat phantom shell. **Clam-shell phones** should be positioned with the hinge against a smooth edge of the flat phantom where the upper half of the phone is unfolded and extended beyond the phantom side wall. The lower half of the phone is secured in the test device holder at a fixed distance below the flat phantom determined by the minimum separation along the lower edge of the phone in the cheek touching position using SAM. Any case with substantial variation in separation distance along the lower edge of a clam shell is discussed with the FCC for best-to-use methodology.

The latest IEEE 1528 committee developments propose the usage of a tilted phantom when the antenna of the phone is mounted at the bottom or in all cases the peak absorption is in the chin region. Both SAM heads of the TwinSAM-Chin20 are rotated 20 degrees around the NF line. Each head can be removed individually from the table for emptying and cleaning.

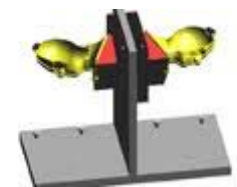

Figure 7-5 Twin SAM Chin20

7.5 Body-Worn Accessory Configurations

Body-worn operating configurations are tested with the belt-clips and holsters attached to the device and positioned against a flat phantom in a normal use configuration (see Figure 7-4). A device with a headset output is tested with a headset connected to the device.

FCC ID: A3LSCHI415	PCTEST ENGINEERING LABORATORY, INC.	SAR EVALUATION REPORT		Reviewed by: Quality Manager
Document S/N: 0Y1205290731.A3L	Test Dates: 05/31/12 - 06/19/12	DUT Type: Portable Handset		Page 16 of 61



Accessories for Body-worn operation configurations are divided into two categories: those that do not contain metallic components and those that do contain metallic components. When multiple accessories that do not contain metallic components are supplied with the device, the device is tested with only the accessory that dictates the closest spacing to the body. Then multiple accessories that contain metallic components are tested with the device with each accessory. If multiple accessories share an identical metallic component (i.e. the same metallic belt-clip used with different holsters with no other metallic components) only the accessory that dictates the closest spacing to the body is tested.

Body-worn accessories may not always be supplied or available as options for some devices intended to be authorized for body-worn use. In this case, a test configuration with a separation distance between the back of the device and the flat phantom is used. Test position spacing was documented. Transmitters that are designed to operate in front of a person's face, as in push-to-talk configurations, are tested for SAR compliance with the front of the device positioned to face the flat phantom in head fluid. For devices that are carried next to the body such as a shoulder, waist or chest-worn transmitters, SAR compliance is tested with the accessories, including headsets and microphones, attached to the device and positioned against a flat phantom in a normal use configuration.

7.6 Wireless Router Configurations

Some battery-operated handsets have the capability to transmit and receive internet connectivity through simultaneous transmission of WIFI in conjunction with a separate licensed transmitter. The FCC has provided guidance in KDB Publication 941225 D06 where SAR test considerations for handsets ($L \times W \geq 9 \text{ cm} \times 5 \text{ cm}$) are based on a composite test separation distance of 10 mm from the front, back and edges of the device with antennas 2.5 cm or closer to the edge of the device, determined from general mixed use conditions for this type of devices. Since the hotspot SAR results may overlap with the body-worn accessory SAR requirements, the more conservative configurations can be considered, thus excluding some body-worn accessory SAR tests.

When the user enables the personal wireless router functions for the handset, actual operations include simultaneous transmission of both the WIFI transmitter and another licensed transmitter. Both transmitters often do not transmit at the same transmitting frequency and thus cannot be evaluated for SAR under actual use conditions. Therefore, SAR must be evaluated for each frequency transmission and mode separately and summed with the WIFI transmitter according to KDB 648474 publication procedures. The "Portable Hotspot" feature on the handset was NOT activated, to ensure the SAR measurements were evaluated for a single transmission frequency RF signal.

FCC ID: A3LSCHI415		SAR EVALUATION REPORT		Reviewed by: Quality Manager
Document S/N: 0Y1205290731.A3L	Test Dates: 05/31/12 - 06/19/12	DUT Type: Portable Handset	Page 17 of 61	

8 FCC RF EXPOSURE LIMITS

8.1 Uncontrolled Environment

UNCONTROLLED ENVIRONMENTS are defined as locations where there is the exposure of individuals who have no knowledge or control of their exposure. The general population/uncontrolled exposure limits are applicable to situations in which the general public may be exposed or in which persons who are exposed as a consequence of their employment may not be made fully aware of the potential for exposure or cannot exercise control over their exposure. Members of the general public would come under this category when exposure is not employment-related; for example, in the case of a wireless transmitter that exposes persons in its vicinity.



8.2 Controlled Environment

CONTROLLED ENVIRONMENTS are defined as locations where there is exposure that may be incurred by persons who are aware of the potential for exposure, (i.e. as a result of employment or occupation). In general, occupational/controlled exposure limits are applicable to situations in which persons are exposed as a consequence of their employment, who have been made fully aware of the potential for exposure and can exercise control over their exposure. This exposure category is also applicable when the exposure is of a transient nature due to incidental passage through a location where the exposure levels may be higher than the general population/uncontrolled limits, but the exposed person is fully aware of the potential for exposure and can exercise control over his or her exposure by leaving the area or by some other appropriate means.

Table 8-1
SAR Human Exposure Specified in ANSI/IEEE C95.1-1992 and Health Canada Safety Code 6

HUMAN EXPOSURE LIMITS		
	UNCONTROLLED ENVIRONMENT <i>General Population</i> (W/kg) or (mW/g)	CONTROLLED ENVIRONMENT <i>Occupational</i> (W/kg) or (mW/g)
SPATIAL PEAK SAR Brain	1.6	8.0
SPATIAL AVERAGE SAR Whole Body	0.08	0.4
SPATIAL PEAK SAR Hands, Feet, Ankles, Wrists	4.0	20

1. The Spatial Peak value of the SAR averaged over any 1 gram of tissue (defined as a tissue volume in the shape of a cube) and over the appropriate averaging time.
2. The Spatial Average value of the SAR averaged over the whole body.
3. The Spatial Peak value of the SAR averaged over any 10 grams of tissue (defined as a tissue volume in the shape of a cube) and over the appropriate averaging time.

FCC ID: A3LSCHI415	 PCTEST ENGINEERING LABORATORY, INC.	SAR EVALUATION REPORT		Reviewed by: Quality Manager
Document S/N: 0Y1205290731.A3L	Test Dates: 05/31/12 - 06/19/12	DUT Type: Portable Handset		Page 18 of 61

9

FCC MEASUREMENT PROCEDURES

Power measurements were performed using a base station simulator under digital average power.

9.1 Procedures Used to Establish RF Signal for SAR

The following procedures are according to FCC KDB Publication 941225 D01 "SAR Measurement Procedures for 3G Devices" v02, October 2007.

The device was placed into a simulated call using a base station simulator in a RF shielded chamber. Establishing connections in this manner ensure a consistent means for testing SAR and are recommended for evaluating SAR [4]. Devices under test were evaluated prior to testing, with a fully charged battery and were configured to operate at maximum output power. In order to verify that the device was tested throughout the SAR test at maximum output power, the SAR measurement system measures a "point SAR" at an arbitrary reference point at the start and end of the 1 gram SAR evaluation, to assess for any power drifts during the evaluation. If the power drift deviated by more than 5%, the SAR test and drift measurements were repeated.

9.2 SAR Measurement Conditions for CDMA2000

The following procedures were performed according to FCC KDB Publication 941225 D01 "SAR Measurement Procedures for 3G Devices" v02, October 2007.

9.2.1 Output Power Verification

See 3GPP2 C.S0011/TIA-98-E as recommended by "SAR Measurement Procedures for 3G Devices" v02, October 2007. Maximum output power is verified on the High, Middle and Low channels according to procedures in section 4.4.5.2 of 3GPP2 C.S0011/TIA-98-E. SO55 tests were measured with power control bits in the "All Up" condition.

1. If the mobile station (MS) supports Reverse TCH RC 1 and Forward TCH RC 1, set up a call using Fundamental Channel Test Mode 1 (RC=1/1) with 9600 bps data rate only.
2. Under RC1, C.S0011 Table 4.4.5.2-1, Table 9-1 parameters were applied.
3. If the MS supports the RC 3 Reverse FCH, RC3 Reverse SCH₀ and demodulation of RC 3,4, or 5, set up a call using Supplemental Channel Test Mode 3 (RC 3/3) with 9600 bps Fundamental Channel and 9600 bps SCH0 data rate.
4. Under RC3, C.S0011 Table 4.4.5.2-2, Table 9-2 was applied.
5. FCHs were configured at full rate for maximum SAR with "All Up" power control bits.

Table 9-1
Parameters for Max. Power for RC1



Parameter	Units	Value
I_{or}	dBm/1.23 MHz	-104
$\frac{Pilot E_c}{I_{or}}$	dB	-7
$\frac{Traffic E_c}{I_{or}}$	dB	-7.4

Table 9-2
Parameters for Max. Power for RC3

Parameter	Units	Value
I_{or}	dBm/1.23 MHz	-86
$\frac{Pilot E_c}{I_{or}}$	dB	-7
$\frac{Traffic E_c}{I_{or}}$	dB	-7.4

9.2.2 Head SAR Measurements

SAR for head exposure configurations is measured in RC3 with the DUT configured to transmit at full rate using Loopback Service Option SO55. SAR for RC1 is not required when the maximum average output of each channel is less than ¼ dB higher than that measured in RC3. Otherwise, SAR is measured on the maximum output channel in RC1 using the exposure configuration that results in the highest SAR for that channel in RC3.

FCC ID: A3LSCH1415	 PCTEST ENGINEERING LABORATORY, INC.	SAR EVALUATION REPORT		Reviewed by: Quality Manager
Document S/N: 0Y1205290731.A3L	Test Dates: 05/31/12 - 06/19/12	DUT Type: Portable Handset	Page 19 of 61	

9.2.3 Body SAR Measurements

SAR for body exposure configurations is measured in RC3 with the DUT configured to transmit at full rate on FCH with all other code channels disabled using TDSO / SO32. SAR for multiple code channels (FCH + SCH_n) is not required when the maximum average output of each RF channel is less than ¼ dB higher than that measured with FCH only. Otherwise, SAR is measured on the maximum output channel (FCH + SCH_n) with FCH at full rate and SCH₀ enabled at 9600 bps using the exposure configuration that results in the highest SAR for that channel with FCH only. When multiple code channels are enabled, the DUT output may shift by more than 0.5 dB and lead to higher SAR drifts and SCH dropouts. Body SAR was measured using TDSO / SO32 with power control bits in the “All Up”

Body SAR in RC1 is not required when the maximum average output of each channel is less than ¼ dB higher than that measured in RC3. Otherwise, SAR is measured on the maximum output channel in RC1; with Loopback Service Option SO55, at full rate, using the body exposure configuration that results in the highest SAR for that channel in RC3.

9.2.4 Handsets with EVDO

For handsets with Ev-Do capabilities, when the maximum average output of each channel in Rev. 0 is less than ¼ dB higher than that measured in RC3 (1x RTT), body SAR for EV-DO is not required. Otherwise, SAR for Rev. 0 is measured on the maximum output channel at 153.6 kbps using the body exposure configuration that results in the highest SAR for that channel in RC3. SAR for Rev. A is not required when the maximum average output of each channel is less than that measured in Rev. 0 or less than ¼ dB higher than that measured in RC3. Otherwise, SAR is measured on the maximum output channel for Rev. A using a Reverse Data Channel payload size of 4096 bits and a Termination Target of 16 slots defined for Subtype 2 Physical Layer configurations. A Forward Traffic Channel data rate corresponding to the 2-slot version of 307.2 kbps with the ACK Channel transmitting in all slots would be configured in the downlink for both Rev. 0 and Rev. A.

9.2.5 Body SAR Measurements for EVDO Hotspot



Hotspot Body SAR is measured using Subtype 0/1 Physical Layer configurations for Rev. 0 per KDB Publication 941225 D01 procedures for “1x Ev-Do data Devices”. SAR for Subtype 2 Physical layer configurations is not required for Rev. A when the maximum average output of each RF channels is less than that measured in Subtype 0/1 Physical layer configurations. Otherwise, SAR is measured on the maximum output channel for Rev. A for the configuration that produced the highest SAR with Rev. 0 using a Reverse Data Channel payload size of 4096 bits and a Termination Target of 16 slots defined for Subtype 2 Physical Layer configurations. A Forward Traffic Channel data rate corresponding to the 2-slot version of 307.2 kbps with the ACK Channel transmitting in all slots would be configured in the downlink for both Rev. 0 and Rev. A.

9.3 SAR Measurement Conditions for LTE

LTE modes were tested according to FCC KDB 941225 D05 publication. Please see Section 9.3.3 for required test configurations. Establishing connections with base station simulators ensure a consistent means for testing SAR and are recommended for evaluating SAR [4]. The R&S CMW500 was used for LTE output power measurements and SAR testing. Closed loop power control was used so the UE transmits with maximum output power during SAR testing.

9.3.1 MPR

MPR is implemented for this device by the manufacturer when the transmit power is not limited by the power reduction mechanism. The specific manufacturer target MPR is indicated alongside the

FCC ID: A3LSCHI415	 PCTEST ENGINEERING LABORATORY, INC.	SAR EVALUATION REPORT		Reviewed by: Quality Manager
Document S/N: 0Y1205290731.A3L	Test Dates: 05/31/12 - 06/19/12	DUT Type: Portable Handset		Page 20 of 61

SAR results. MPR is enabled for this device, according to 3GPP TS36.101 Section 6.2.3 – 6.2.5 under Table 6.2.3-1. See Section 10.3 and Section 11.3 for MPR targets.

9.3.2 A-MPR

A-MPR (Additional MPR) has been disabled for all SAR tests by setting NS=01 on the base station simulator.

9.3.3 Required RB Size and RB Offsets for SAR Testing

Per FCC KDB 941225 D05, Page 2, footnote 1, the available channels are tested when LTE bands that do not support at least 3 channels in certain bandwidths. There is only one 10 MHz channel in LTE Band 13.

According to FCC KDB 941225 D05:

- a. Per Page 4, 3) A), QPSK with 50% RB is required for the highest bandwidth.
- b. Per Page 4, 3) B), QPSK with 1 RB for both channel edges are required.
- c. Per Page 4, 4) A), 16QAM with 50% RB is required.
- d. Per Page 4, 4) B), 16QAM with 1RB for both channel edges are.
- e. Per Page 4, 4), A) I) and Page 5, 4), A)I), 100% RB Allocation is not required to be tested when the 50% RB SAR is not > 1.45 W/kg for the highest bandwidth.

9.4 SAR Testing with 802.11 Transmitters

Normal network operating configurations are not suitable for measuring the SAR of 802.11 a/b/g/n transmitters. Unpredictable fluctuations in network traffic and antenna diversity conditions can introduce undesirable variations in SAR results. The SAR for these devices should be measured using chipset based test mode software to ensure the results are consistent and reliable. See KDB Publication 248227 for more details.

9.4.1 General Device Setup



Chipset based test mode software is hardware dependent and generally varies among manufacturers. The device operating parameters established in test mode for SAR measurements must be identical to those programmed in production units, including output power levels, amplifier gain settings and other RF performance tuning parameters. The test frequencies should correspond to actual channel frequencies defined for domestic use. SAR for devices with switched diversity should be measured with only one antenna transmitting at a time during each SAR measurement, according to a fixed modulation and data rate. The same data pattern should be used for all measurements.

9.4.2 Frequency Channel Configurations [27]

For 2.4 GHz, the highest average RF output power channel between the low, mid and high channel at the lowest data rate was selected for SAR evaluation in 802.11b mode. 802.11g/n modes and higher data rates for 802.11b were additionally evaluated for SAR if the output power of the respective mode was 0.25 dB or higher than the powers of the SAR configurations tested in the 802.11b mode.

For 5 GHz, the highest average RF output power channel across the default test channels at the lowest data rate was selected for SAR evaluation in 802.11a. When the adjacent channels are higher in power than the default channels, these “required channels” were considered instead of the default channels for SAR testing. 802.11n modes and higher data rates for 802.11a/n were evaluated only if the respective mode was 0.25 dB or higher than the 802.11a mode.

If the maximum extrapolated peak SAR of the zoom scan for the highest output channel was less than 1.6 W/kg or if the 1g averaged SAR was less than 0.8 W/kg, SAR testing was not required for the other test channels in the band.

FCC ID: A3LSCHI415	 PCTEST ENGINEERING LABORATORY, INC.	SAR EVALUATION REPORT		Reviewed by: Quality Manager
Document S/N: 0Y1205290731.A3L	Test Dates: 05/31/12 - 06/19/12	DUT Type: Portable Handset		Page 21 of 61

10 RF CONDUCTED POWERS

10.1 Standalone CDMA Conducted Powers

Table 10-1
CDMA/EVDO Average RF Power

Band	Channel	Frequency	SO55 [dBm]	SO55 [dBm]	TDSO SO32 [dBm]	TDSO SO32 [dBm]	1x EvDO Rev. 0 [dBm]	1x EvDO Rev. A [dBm]
	F-RC	MHz	RC1	RC3	FCH+SCH	FCH	(RTAP)	(RETAP)
Cellular	1013	824.7	24.44	24.41	24.31	24.31	24.36	24.34
	384	836.52	24.46	24.39	24.26	24.33	24.32	24.31
	777	848.31	24.36	24.33	24.27	24.29	24.29	24.28
PCS	25	1851.25	24.61	24.57	24.51	24.53	24.51	24.45
	600	1880	24.54	24.51	24.47	24.55	24.49	24.45
	1175	1908.75	24.61	24.55	24.53	24.56	24.53	24.50

Note: RC1 is only applicable for IS-95 compatibility.

Per KDB Publication 941225 D01:

1. Head SAR was tested with SO55 RC3. SO55 RC1 was not required since the average output power was not more than 0.25 dB than the SO55 RC3 powers.
2. Body-Worn SAR was tested with 1x RTT with TDSO / SO32 FCH Only. TDSO / SO32 FCH+SCH SAR tests were not required since the average output power was not more than 0.25 dB higher than the TDSO / SO32 FCH only powers.
3. According to FCC KDB 941225, EVDO SAR (Hotspot) is measured using Subtype 0/1 Physical Layer configurations for Rev. 0. When the maximum output power of Rev. A for each channel is greater than the Rev.0 power, Rev. A must additionally be tested using the highest output channel for the configuration that resulted in the highest SAR for Rev.0.
4. CDMA 1x-RTT SAR was required to be evaluated for Hotspot exposure conditions to support simultaneous capabilities per Table 1-2.



Figure 10-1
Power Measurement Setup

FCC ID: A3LSCHI415	PCTEST ENGINEERING LABORATORY, INC.	SAR EVALUATION REPORT	SAMSUNG	Reviewed by: Quality Manager
Document S/N: 0Y1205290731.A3L	Test Dates: 05/31/12 - 06/19/12	DUT Type: Portable Handset		Page 22 of 61

10.2 Standalone GSM Conducted Powers

**Table 10-2
GSM/GPRS/EDGE Average RF Power**

		Maximum Burst-Averaged Output Power				
		Voice	GPRS/EDGE Data (GMSK)		EDGE Data (8-PSK)	
Band	Channel	GSM [dBm] CS (1 Slot)	GPRS [dBm] 1 Tx Slot	GPRS [dBm] 2 Tx Slot	EDGE [dBm] 1 Tx Slot	EDGE [dBm] 2 Tx Slot
Cellular	128	32.25	32.29	29.85	26.74	26.55
	190	32.46	32.48	29.93	26.84	26.61
	251	32.05	32.10	29.71	26.84	26.64
PCS	512	29.92	29.93	28.59	25.51	25.37
	661	30.01	30.00	28.80	25.54	25.48
	810	29.99	30.02	28.94	25.49	25.35

		Calculated Maximum Frame-Averaged Output Power				
		Voice	GPRS/EDGE Data (GMSK)		EDGE Data (8-PSK)	
Band	Channel	GSM [dBm] CS (1 Slot)	GPRS [dBm] 1 Tx Slot	GPRS [dBm] 2 Tx Slot	EDGE [dBm] 1 Tx Slot	EDGE [dBm] 2 Tx Slot
Cellular	128	23.22	23.26	23.83	17.71	20.53
	190	23.43	23.45	23.91	17.81	20.59
	251	23.02	23.07	23.69	17.81	20.62
PCS	512	20.89	20.90	22.57	16.48	19.35
	661	20.98	20.97	22.78	16.51	19.46
	810	20.96	20.99	22.92	16.46	19.33

Note: Both burst-averaged and calculated frame-averaged powers are included. Frame-averaged power was calculated from the measured burst-averaged power by converting the slot powers into linear units and calculating the energy over 8 timeslots.

The bolded GPRS modes were selected according to the highest frame-averaged output power table according to KDB 941225 D03.

GPRS/EDGE (GMSK) output powers were measured with CS1 on the base station simulator. CS1 coding scheme was used in GPRS output power measurements and SAR Testing, as a condition where GMSK modulation was ensured. Investigation has shown that CS1 - CS4 settings do not have any impact on the output levels in the GPRS modes. EDGE (8-PSK) output powers were measured with MCS7 on the base station simulator. MCS7 coding scheme was used to measure the output powers for EDGE since investigation has shown that choosing MCS7 coding scheme will ensure 8-PSK modulation and MCS levels that produce 8-PSK modulation do not have an impact on output power levels.

GSM Class: B
GPRS Multislot class: 10 (max 2 Tx Uplink slots)
EDGE Multislot class: 10 (max 2Tx Uplink slots)
DTM Multislot Class: N/A



**Figure 10-2
Power Measurement Setup**

FCC ID: A3LSCHI415	PCTEST ENGINEERING LABORATORY, INC.	SAR EVALUATION REPORT	SAMSUNG	Reviewed by: Quality Manager
Document S/N: 0Y1205290731.A3L	Test Dates: 05/31/12 - 06/19/12	DUT Type: Portable Handset	Page 23 of 61	

10.3 Standalone LTE Conducted Powers

Table 10-3
LTE Band 13 RF Conducted Powers

Frequency [MHz]	Channel	Bandwidth [MHz]	Modulation	RB Size	RB Offset	Conducted Power [dBm]	Target MPR [dB]	MPR Allowed per 3GPP [dB]
782.0	23230	10	QPSK	1	0	22.89	0	0
782.0	23230	10	QPSK	1	49	22.76	0	0
782.0	23230	10	QPSK	25	12	22.24	1	0-1
782.0	23230	10	QPSK	50	0	22.31	1	0-1
782.0	23230	10	16QAM	1	0	22.08	1	0-1
782.0	23230	10	16QAM	1	49	21.96	1	0-1
782.0	23230	10	16QAM	25	12	20.91	2	0-2
782.0	23230	10	16QAM	50	0	20.89	2	0-2

10.3.1 Required RB Size and RB Offsets for SAR Testing

According to FCC KDB 941225 D05:

- 1) Per Page 4, 3) A), QPSK with 50% RB is required.
- 2) Per Page 4, 3) B), QPSK with 1 RB for both channel edges are required.
- 3) Per Page 4, 4) A), 16QAM with 50% RB is required.
- 4) Per Page 4, 4) B), 16QAM with 1RB for both channel edges are required.
- 5) Per Page 4, 4), A) I) and Page 5, 4), A),I), 100% RB Allocation is not required to be tested when the 50% RB SAR is not > 1.45 W/kg for the highest bandwidth.
- 6) The bolded configurations above were tested for SAR.

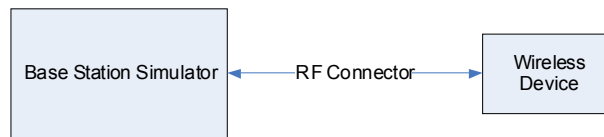

Figure 10-3
Power Measurement Setup

10.4 WLAN Conducted Powers

Table 10-4
IEEE 802.11b Average RF Power

Mode	Freq [MHz]	Channel	Conducted Power [dBm]			
			Data Rate [Mbps]			
			1	2	5.5	11
802.11b	2412	1	16.45	15.68	16.13	15.78
802.11b	2437	6	15.19	14.36	14.36	14.51
802.11b	2462	11	14.83	14.17	14.14	14.13

FCC ID: A3LSCHI415	PCTEST ENGINEERING LABORATORY, INC.	SAR EVALUATION REPORT		Reviewed by: Quality Manager
Document S/N: 0Y1205290731.A3L	Test Dates: 05/31/12 - 06/19/12	DUT Type: Portable Handset		Page 24 of 61

**Table 10-5
IEEE 802.11g Average RF Power**

Mode	Freq [MHz]	Channel	Conducted Power [dBm]							
			Data Rate [Mbps]							
	6	9	12	18	24	36	48	54		
802.11g	2412	1	9.81	9.43	9.25	9.52	8.96	9.41	9.22	8.76
802.11g	2437	6	8.42	7.61	7.12	7.96	8.14	8.57	8.15	8.29
802.11g	2462	11	7.52	7.48	7.54	7.46	7.37	7.73	7.14	7.05

**Table 10-6
IEEE 802.11n Average RF Power**

Mode	Freq [MHz]	Channel	Conducted Power [dBm]							
			Data Rate [Mbps]							
	6.5	13	20	26	39	52	58	65		
802.11n	2412	1	9.26	8.95	8.91	9.05	8.89	9.23	8.62	9.02
802.11n	2437	6	7.37	7.52	7.45	7.26	8.06	7.52	7.17	7.59
802.11n	2462	11	6.63	7.00	6.84	6.12	6.67	6.91	7.01	6.79

**Table 10-7
IEEE 802.11a Average RF Power**

Mode	Freq [MHz]	Channel	Conducted Power [dBm]							
			Data Rate [Mbps]							
	6	9	12	18	24	36	48	54		
802.11a	5180	36*	11.87	11.93	11.91	11.94	12.01	11.93	11.97	11.91
802.11a	5200	40	11.96	12.01	12.03	12.03	12.02	11.97	11.99	12.07
802.11a	5220	44	12.18	12.15	12.11	12.13	12.12	12.10	12.08	12.13
802.11a	5240	48*	12.06	11.98	12.02	12.01	11.99	11.93	11.91	11.98
802.11a	5260	52*	12.21	12.19	12.16	12.19	12.22	12.21	12.25	12.23
802.11a	5280	56	12.32	12.27	12.28	12.28	12.30	12.27	12.29	12.28
802.11a	5300	60	12.46	12.52	12.51	12.54	12.52	12.49	12.50	12.52
802.11a	5320	64*	12.73	12.74	12.72	12.76	12.74	12.80	12.71	12.73
802.11a	5500	100	12.65	12.65	12.69	12.71	12.68	12.67	12.66	12.72
802.11a	5520	104*	12.66	12.61	12.69	12.65	12.62	12.64	12.62	12.65
802.11a	5540	108	12.65	12.66	12.68	12.64	12.66	12.64	12.61	12.63
802.11a	5560	112	12.75	12.78	12.76	12.76	12.79	12.78	12.77	12.76
802.11a	5580	116*	12.68	12.74	12.71	12.72	12.71	12.73	12.70	12.76
802.11a	5600	120	N/A	N/A	N/A	N/A	N/A	N/A	N/A	N/A
802.11a	5620	124	N/A	N/A	N/A	N/A	N/A	N/A	N/A	N/A
802.11a	5640	128	N/A	N/A	N/A	N/A	N/A	N/A	N/A	N/A
802.11a	5660	132	12.59	12.61	12.59	12.62	12.54	12.59	12.58	12.57
802.11a	5680	136*	12.44	12.46	12.45	12.43	12.47	12.45	12.47	12.45
802.11a	5700	140	12.75	12.76	12.75	12.78	12.75	12.79	12.78	12.74
802.11a	5745	149*	12.70	12.68	12.66	12.63	12.70	12.68	12.67	12.68
802.11a	5765	153	12.80	12.76	12.77	12.78	12.76	12.75	12.73	12.68
802.11a	5785	157*	12.81	12.78	12.80	12.85	12.80	12.78	12.81	12.79
802.11a	5805	161*	12.55	12.54	12.59	12.65	12.57	12.60	12.65	12.59
802.11a	5825	165	12.51	12.49	12.55	12.53	12.51	12.47	12.49	12.52

Per FCC KDB Publication 443999 and RSS-210 A9.2(3), transmission on channels which overlap the 5600-5650 MHz is prohibited as a client. This device does not transmit any beacons or initiate any transmissions in 5.3 and 5.5 GHz Band. (*) – indicates default channels per KDB Publication 248227. When the adjacent channels are higher in power then the default channels, these “required channels” are considered instead of the default channels for SAR testing.



FCC ID: A3LSCHI415	 PCTEST ENGINEERING LABORATORY, INC.	SAR EVALUATION REPORT		Reviewed by: Quality Manager
Document S/N: 0Y1205290731.A3L	Test Dates: 05/31/12 - 06/19/12	DUT Type: Portable Handset		Page 25 of 61

Table 10-8
IEEE 802.11n (20 MHz) Average RF Power



Mode	Freq [MHz]	Channel	Conducted Power [dBm]							
			Data Rate [Mbps]							
			6.5	13	20	26	39	52	58	65
802.11n	5180	36*	11.89	11.90	11.92	11.90	11.89	11.89	11.85	11.87
802.11n	5200	40	11.93	11.89	11.93	11.91	11.89	11.88	11.89	11.91
802.11n	5220	44	12.08	12.09	12.06	12.08	12.08	12.07	12.09	12.08
802.11n	5240	48*	12.12	12.14	12.15	12.11	12.12	12.13	12.14	12.13
802.11n	5260	52*	12.32	12.29	12.30	12.33	12.34	12.32	12.29	12.27
802.11n	5280	56	12.27	12.19	12.21	12.28	12.29	12.25	12.21	12.26
802.11n	5300	60	12.34	12.49	12.46	12.47	12.50	12.48	12.45	12.46
802.11n	5320	64*	12.57	12.56	12.60	12.61	12.60	12.58	12.63	12.58
802.11n	5500	100	12.71	12.75	12.73	12.73	12.72	12.71	12.73	12.74
802.11n	5520	104*	12.68	12.72	12.70	12.67	12.67	12.65	12.71	12.73
802.11n	5540	108	12.82	12.81	12.77	12.83	12.79	12.80	12.82	12.81
802.11n	5560	112	12.89	12.87	12.88	12.87	12.86	12.89	12.87	12.90
802.11n	5580	116*	12.71	12.75	12.73	12.75	12.76	12.78	12.75	12.72
802.11n	5600	120	N/A	N/A	N/A	N/A	N/A	N/A	N/A	N/A
802.11n	5620	124	N/A	N/A	N/A	N/A	N/A	N/A	N/A	N/A
802.11n	5640	128	N/A	N/A	N/A	N/A	N/A	N/A	N/A	N/A
802.11n	5660	132	12.74	12.72	12.71	12.67	12.70	12.71	12.69	12.70
802.11n	5680	136*	12.53	12.53	12.56	12.59	12.54	12.61	12.59	12.55
802.11n	5700	140	12.50	12.51	12.53	12.51	12.49	12.52	12.53	12.51
802.11n	5745	149*	12.69	12.70	12.69	12.68	12.66	12.70	12.69	12.66
802.11n	5765	153	12.76	12.79	12.77	12.76	12.78	12.74	12.78	12.72
802.11n	5785	157*	12.73	12.71	12.69	12.66	12.72	12.70	12.71	12.69
802.11n	5805	161*	12.59	12.62	12.59	12.67	12.59	12.60	12.56	12.58
802.11n	5825	165	12.67	12.68	12.69	12.68	12.71	12.63	12.69	12.66

Per FCC KDB Publication 443999 and RSS-210 A9.2(3), transmission on channels which overlap the 5600-5650 MHz is prohibited as a client. This device does not transmit any beacons or initiate any transmissions in 5.3 and 5.5 GHz Bands. (*) – indicates default channels per KDB Publication 248227. When the adjacent channels are higher in power than the default channels, these “required channels” are considered instead of the default channels for SAR testing.

Table 10-9
IEEE 802.11n (40 MHz) Average RF Power

Mode	Freq [MHz]	Channel	802.11n (40MHz Bandwidth) Conducted Power [dBm]							
			Data Rate [Mbps]							
			13.5/15	27/30	40.5/45	54/60	81/90	108/120	121.5/135	135/150
802.11n	5190	38*	11.79	11.78	11.81	11.76	11.80	11.78	11.81	11.79
802.11n	5230	46	11.45	11.42	11.51	11.50	11.45	11.48	11.42	11.48
802.11n	5270	54	11.32	11.19	11.18	11.23	11.14	11.21	11.19	11.20
802.11n	5310	62*	12.86	12.82	12.94	12.92	12.88	12.91	12.86	12.90
802.11n	5510	102	11.78	11.81	11.74	11.79	11.82	11.80	11.79	11.76
802.11n	5550	110	11.34	11.41	11.45	11.43	11.42	11.43	11.41	11.46
802.11n	5590	118	N/A	N/A	N/A	N/A	N/A	N/A	N/A	N/A
802.11n	5630	126	N/A	N/A	N/A	N/A	N/A	N/A	N/A	N/A
802.11n	5670	134	12.87	12.93	12.90	12.92	12.99	12.98	12.89	12.96
802.11n	5755	151*	11.42	11.34	11.46	11.46	11.48	11.41	11.49	11.52
802.11n	5795	159	11.51	11.52	11.54	11.52	11.59	11.61	11.61	11.56

Per FCC KDB Publication 443999 and RSS-210 A9.2(3), transmission on channels which overlap the 5600-5650 MHz is prohibited as a client. This device does not transmit any beacons or initiate any transmissions in 5.3 and 5.5 GHz Bands. (*) – indicates default channels per KDB Publication 248227. When the adjacent channels are higher in power than the default channels, these “required channels” are considered instead of the default channels for SAR testing.



FCC ID: A3LSCHI415	 PCTEST Engineering Laboratory, Inc.	SAR EVALUATION REPORT		Reviewed by: Quality Manager
Document S/N: 0Y1205290731.A3L	Test Dates: 05/31/12 - 06/19/12	DUT Type: Portable Handset		Page 26 of 61

Justification for reduced test configurations for WIFI channels per KDB Publication 248227 and April 2010 FCC/TCB Meeting Notes:

- For 2.4 GHz, highest average RF output power channel for the lowest data rate for IEEE 802.11b were selected for SAR evaluation. Other IEEE 802.11 modes (including 802.11g/n) were not investigated since the average output powers over all channels and data rates were not more than 0.25 dB higher than the tested channel in the lowest data rate of IEEE 802.11b mode.
- For 5 GHz, highest average RF output power channel for the lowest data rate for IEEE 802.11a were selected for SAR evaluation. Other IEEE 802.11 modes (including 802.11n for 20MHz and 40 MHz Bandwidth) were not investigated since the average output powers over all channels and data rates were not more than 0.25 dB higher than the tested channel in the lowest data rate of IEEE 802.11a mode.
- When the maximum extrapolated peak SAR of the zoom scan for the maximum output channel is <1.6 W/kg and the 1g averaged SAR is <0.8 W/kg, SAR testing on other channels is not required. Otherwise, the other default (or corresponding required) test channels were additionally tested using the lowest data rate.
- The bolded data rate and channel above were tested for SAR.



Figure 10-4
Power Measurement Setup

FCC ID: A3LSCHI415		SAR EVALUATION REPORT		Reviewed by: Quality Manager
Document S/N: 0Y1205290731.A3L	Test Dates: 05/31/12 - 06/19/12	DUT Type: Portable Handset		Page 27 of 61

11 LTE POWER REDUCTION

11.1 Introduction to LTE Power Reduction

This device is capable of Simultaneous Voice and LTE (SVLTE) calls, with the voice call supported by a CDMA 1xRTT transmitter and the data connection supported by separate LTE transmitter. A LTE power reduction scheme is applied during a LTE connection operating simultaneously with 1x-RTT voice calls. The maximum transmit power of LTE is limited depending on the CDMA 1x voice power level. When CDMA 1x Voice is operating at a certain range of high power levels, maximum LTE transmit power is limited. When CDMA 1x Voice power is below a certain threshold transmit power level, LTE can transmit at the maximum power. Target levels of power reduction and CDMA voice threshold levels are provided in Table 11-1.

**Table 11-1
SVLTE Power Reduction Scheme**



Mode	Voice Avg Power(P) 1x 850/1900 MHz (dBm)	Max. B13 LTE Data Avg Power (dBm)
SVLTE	$P \geq 18$	19
	$P < 18$	23

11.2 Output Power Verification

Per page 7 of KDB Publication 941225 D05, 5) B), output powers were measured in SVLTE mode to determine that the power reduction mechanism was operating reliably and consistently. The power reduction was investigated by simultaneously connecting the device to both LTE and CDMA base station simulators. LTE output powers were measured through conducted RF connections by first connecting the device in a LTE data call and subsequently a CDMA 1xRTT call. CDMA powers were controlled by setting the CDMA base station simulator to active bits. The LTE output power was monitored while changing the CDMA cell output power level.

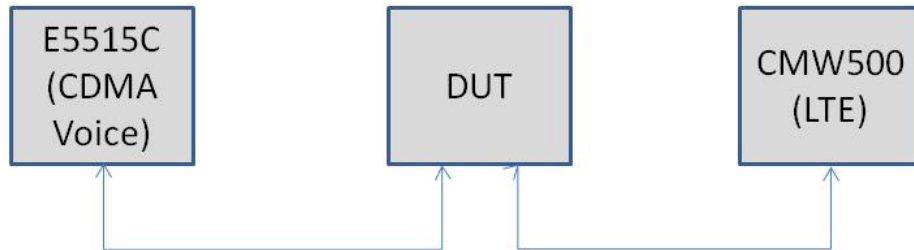
The power reduction targets and threshold level described in Table 11-1 were confirmed. Please see results in Table 11-2 - Table 11-7.



FCC ID: A3LSCHI415	 PCTEST ENGINEERING LABORATORY, INC.	SAR EVALUATION REPORT		Reviewed by: Quality Manager
Document S/N: 0Y1205290731.A3L	Test Dates: 05/31/12 - 06/19/12	DUT Type: Portable Handset		Page 28 of 61

**Table 11-2
SVLTE Power Reduction Verification Results – Low Ch. Cell CDMA**

1x-RTT CDMA Voice Band	BC0 1x-RTT CDMA Voice Channel	BC0 1x-RTT CDMA Voice Tx (dBm)	LTE Band 13 Conducted Power (dBm)							
			QPSK				16QAM			
			1 RB 0 RB Offset	1 RB 49 RB Offset	25 RB 12 RB Offset	50 RB 0 RB Offset	1 RB 0 RB Offset	1 RB 49 RB Offset	25 RB 12 RB Offset	50 RB 0 RB Offset
835 MHz	1013	25	18.65	18.57	19	19.13	19.16	18.86	19.11	19.25
		24	18.65	18.57	19	19.13	19.16	18.86	19.11	19.25
		23	18.65	18.57	19	19.13	19.16	18.86	19.11	19.25
		22	18.65	18.57	19	19.13	19.16	18.86	19.11	19.25
		21	18.65	18.57	19	19.13	19.16	18.86	19.11	19.25
		20	18.65	18.57	19	19.13	19.16	18.86	19.11	19.25
		19	18.65	18.57	19	19.13	19.16	18.86	19.11	19.25
		18	18.65	18.57	19	19.13	19.16	18.86	19.11	19.25
		17	22.75	22.65	22.1	22.09	22.23	22.11	20.99	21.26
		16	22.75	22.65	22.1	22.09	22.23	22.11	20.99	21.26
		15	22.75	22.65	22.1	22.09	22.23	22.11	20.99	21.26
		14	22.75	22.65	22.1	22.09	22.23	22.11	20.99	21.26
		13	22.75	22.65	22.1	22.09	22.23	22.11	20.99	21.26
12	22.75	22.65	22.1	22.09	22.23	22.11	20.99	21.26		
11	22.75	22.65	22.1	22.09	22.23	22.11	20.99	21.26		

**Table 11-3
SVLTE Power Reduction Verification Results – Mid Ch. Cell CDMA**

1x-RTT CDMA Voice Band	BC0 1x-RTT CDMA Voice Channel	BC0 1x-RTT CDMA Voice Tx (dBm)	LTE Band 13 Conducted Power (dBm)							
			QPSK				16QAM			
			1 RB 0 RB Offset	1 RB 49 RB Offset	25 RB 12 RB Offset	50 RB 0 RB Offset	1 RB 0 RB Offset	1 RB 49 RB Offset	25 RB 12 RB Offset	50 RB 0 RB Offset
835 MHz	384	25	18.75	18.56	19	19.15	18.8	19.19	19.01	19.29
		24	18.75	18.56	19	19.15	18.8	19.19	19.01	19.29
		23	18.75	18.56	19	19.15	18.8	19.19	19.01	19.29
		22	18.75	18.56	19	19.15	18.8	19.19	19.01	19.29
		21	18.75	18.56	19	19.15	18.8	19.19	19.01	19.29
		20	18.75	18.56	19	19.15	18.8	19.19	19.01	19.29
		19	18.75	18.56	19	19.15	18.8	19.19	19.01	19.29
		18	18.75	18.56	19	19.15	18.8	19.19	19.01	19.29
		17	22.74	22.68	22.06	22.05	21.76	21.88	20.97	21.27
		16	22.74	22.68	22.06	22.05	21.76	21.88	20.97	21.27
		15	22.74	22.68	22.06	22.05	21.76	21.88	20.97	21.27
		14	22.74	22.68	22.06	22.05	21.76	21.88	20.97	21.27
		13	22.74	22.68	22.06	22.05	21.76	21.88	20.97	21.27
12	22.74	22.68	22.06	22.05	21.76	21.88	20.97	21.27		
11	22.74	22.68	22.06	22.05	21.76	21.88	20.97	21.27		

**Table 11-4
SVLTE Power Reduction Verification Results – High Ch. Cell CDMA**

1x-RTT CDMA Voice Band	BC0 1x-RTT CDMA Voice Channel	BC0 1x-RTT CDMA Voice Tx (dBm)	LTE Band 13 Conducted Power (dBm)							
			QPSK				16QAM			
			1 RB 0 RB Offset	1 RB 49 RB Offset	25 RB 12 RB Offset	50 RB 0 RB Offset	1 RB 0 RB Offset	1 RB 49 RB Offset	25 RB 12 RB Offset	50 RB 0 RB Offset
835 MHz	777	25	18.86	18.55	19	19.09	19.05	18.73	19	19.3
		24	18.86	18.55	19	19.09	19.05	18.73	19	19.3
		23	18.86	18.55	19	19.09	19.05	18.73	19	19.3
		22	18.86	18.55	19	19.09	19.05	18.73	19	19.3
		21	18.86	18.55	19	19.09	19.05	18.73	19	19.3
		20	18.86	18.55	19	19.09	19.05	18.73	19	19.3
		19	18.86	18.55	19	19.09	19.05	18.73	19	19.3
		18	18.86	18.55	19	19.09	19.05	18.73	19	19.3
		17	22.67	22.5	21.78	22.1	21.86	21.57	21.09	21.15
		16	22.67	22.5	21.78	22.1	21.86	21.57	21.09	21.15
		15	22.67	22.5	21.78	22.1	21.86	21.57	21.09	21.15
		14	22.67	22.5	21.78	22.1	21.86	21.57	21.09	21.15
		13	22.67	22.5	21.78	22.1	21.86	21.57	21.09	21.15
12	22.67	22.5	21.78	22.1	21.86	21.57	21.09	21.15		
11	22.67	22.5	21.78	22.1	21.86	21.57	21.09	21.15		

FCC ID: A3LSCH1415		SAR EVALUATION REPORT		Reviewed by: Quality Manager
--------------------	---	------------------------------	---	---------------------------------

Document S/N: 0Y1205290731.A3L	Test Dates: 05/31/12 - 06/19/12	DUT Type: Portable Handset	Page 29 of 61
-----------------------------------	------------------------------------	-------------------------------	---------------

Table 11-5
SVLTE Power Reduction Verification Results – Low Ch. PCS CDMA



1x-RTT CDMA Voice Band	BC0 1x-RTT CDMA Voice Channel	BC0 1x-RTT CDMA Voice Tx (dBm)	LTE Band 13 Conducted Power (dBm)							
			QPSK				16QAM			
			1 RB 0 RB Offset	1 RB 49 RB Offset	25 RB 12 RB Offset	50 RB 0 RB Offset	1 RB 0 RB Offset	1 RB 49 RB Offset	25 RB 12 RB Offset	50 RB 0 RB Offset
1900 MHz	25	25	18.80	18.59	19.04	19.14	19.12	19.12	19	19.2
		24	18.80	18.59	19.04	19.14	19.12	19.12	19	19.2
		23	18.80	18.59	19.04	19.14	19.12	19.12	19	19.2
		22	18.80	18.59	19.04	19.14	19.12	19.12	19	19.2
		21	18.80	18.59	19.04	19.14	19.12	19.12	19	19.2
		20	18.80	18.59	19.04	19.14	19.12	19.12	19	19.2
		19	18.80	18.59	19.04	19.14	19.12	19.12	19	19.2
		18	18.80	18.59	19.04	19.14	19.12	19.12	19	19.2
		17	22.81	22.55	22.02	22.02	21.84	21.95	20.72	21.22
		16	22.81	22.55	22.02	22.02	21.84	21.95	20.72	21.22
		15	22.81	22.55	22.02	22.02	21.84	21.95	20.72	21.22
		14	22.81	22.55	22.02	22.02	21.84	21.95	20.72	21.22
		13	22.81	22.55	22.02	22.02	21.84	21.95	20.72	21.22
12	22.81	22.55	22.02	22.02	21.84	21.95	20.72	21.22		
11	22.81	22.55	22.02	22.02	21.84	21.95	20.72	21.22		

Table 11-6
SVLTE Power Reduction Verification Results – Mid Ch. PCS CDMA

1x-RTT CDMA Voice Band	BC0 1x-RTT CDMA Voice Channel	BC0 1x-RTT CDMA Voice Tx (dBm)	LTE Band 13 Conducted Power (dBm)							
			QPSK				16QAM			
			1 RB 0 RB Offset	1 RB 49 RB Offset	25 RB 12 RB Offset	50 RB 0 RB Offset	1 RB 0 RB Offset	1 RB 49 RB Offset	25 RB 12 RB Offset	50 RB 0 RB Offset
1900 MHz	600	25	18.94	18.8	19.07	19.05	19.27	18.87	19.18	19.27
		24	18.94	18.8	19.07	19.05	19.27	18.87	19.18	19.27
		23	18.94	18.8	19.07	19.05	19.27	18.87	19.18	19.27
		22	18.94	18.8	19.07	19.05	19.27	18.87	19.18	19.27
		21	18.94	18.8	19.07	19.05	19.27	18.87	19.18	19.27
		20	18.94	18.8	19.07	19.05	19.27	18.87	19.18	19.27
		19	18.94	18.8	19.07	19.05	19.27	18.87	19.18	19.27
		18	18.94	18.8	19.07	19.05	19.27	18.87	19.18	19.27
		17	22.58	22.5	21.76	21.92	22.11	22.14	20.98	21.21
		16	22.58	22.5	21.76	21.92	22.11	22.14	20.98	21.21
		15	22.58	22.5	21.76	21.92	22.11	22.14	20.98	21.21
		14	22.58	22.5	21.76	21.92	22.11	22.14	20.98	21.21
		13	22.58	22.5	21.76	21.92	22.11	22.14	20.98	21.21
12	22.58	22.5	21.76	21.92	22.11	22.14	20.98	21.21		
11	22.58	22.5	21.76	21.92	22.11	22.14	20.98	21.21		

Table 11-7
SVLTE Power Reduction Verification Results – High Ch. PCS CDMA

1x-RTT CDMA Voice Band	BC0 1x-RTT CDMA Voice Channel	BC0 1x-RTT CDMA Voice Tx (dBm)	LTE Band 13 Conducted Power (dBm)							
			QPSK				16QAM			
			1 RB 0 RB Offset	1 RB 49 RB Offset	25 RB 12 RB Offset	50 RB 0 RB Offset	1 RB 0 RB Offset	1 RB 49 RB Offset	25 RB 12 RB Offset	50 RB 0 RB Offset
1900 MHz	1175	25	18.74	18.5	19.02	19.15	18.74	18.94	18.99	19.22
		24	18.74	18.5	19.02	19.15	18.74	18.94	18.99	19.22
		23	18.74	18.5	19.02	19.15	18.74	18.94	18.99	19.22
		22	18.74	18.5	19.02	19.15	18.74	18.94	18.99	19.22
		21	18.74	18.5	19.02	19.15	18.74	18.94	18.99	19.22
		20	18.74	18.5	19.02	19.15	18.74	18.94	18.99	19.22
		19	18.74	18.5	19.02	19.15	18.74	18.94	18.99	19.22
		18	18.74	18.5	19.02	19.15	18.74	18.94	18.99	19.22
		17	22.60	22.5	22.02	22.03	21.61	21.65	21.04	21.26
		16	22.60	22.5	22.02	22.03	21.61	21.65	21.04	21.26
		15	22.60	22.5	22.02	22.03	21.61	21.65	21.04	21.26
		14	22.60	22.5	22.02	22.03	21.61	21.65	21.04	21.26
		13	22.60	22.5	22.02	22.03	21.61	21.65	21.04	21.26
12	22.60	22.5	22.02	22.03	21.61	21.65	21.04	21.26		
11	22.60	22.5	22.02	22.03	21.61	21.65	21.04	21.26		

FCC ID: A3LSCH1415		SAR EVALUATION REPORT		Reviewed by: Quality Manager
Document S/N: 0Y1205290731.A3L	Test Dates: 05/31/12 - 06/19/12	DUT Type: Portable Handset		Page 30 of 61

11.3 SVLTE SAR Testing Procedures



SAR testing was additionally performed at the reduced CDMA and LTE power levels with respect to the various SVLTE simultaneous transmission scenarios. Additional samples were tuned to reduced power levels for the purpose of evaluating the simultaneous SAR based on the sum SAR of standalone 1x-RTT CDMA and standalone LTE combinations. While the power reduction mechanism is activated at the CDMA Voice power level of 18 dBm, simultaneous SAR summations were evaluated maximum power LTE. SAR was additionally evaluated at reduced power LTE levels to perform simultaneous SAR analysis when CDMA voice is at maximum output power.

**Table 11-8
Reduced LTE Conducted Powers**

Frequency [MHz]	Channel	Bandwidth [MHz]	Modulation	RB Size	RB Offset	Conducted Power [dBm]	Target MPR [dB]	MPR Allowed per 3GPP [dB]
782.0	23230	10	QPSK	1	0	18.91	0	0
782.0	23230	10	QPSK	1	49	19.07	0	0
782.0	23230	10	QPSK	25	12	18.98	0	0-1
782.0	23230	10	QPSK	50	0	19.15	0	0-1
782.0	23230	10	16QAM	1	0	18.75	0	0-1
782.0	23230	10	16QAM	1	49	18.77	0	0-1
782.0	23230	10	16QAM	25	12	19.23	0	0-2
782.0	23230	10	16QAM	50	0	19.26	0	0-2

According to FCC KDB 941225 D05:

- 1) Per Page 4, 3) A), QPSK with 50% RB is required.
- 2) Per Page 4, 3) B), QPSK with 1 RB for both channel edges are required.
- 3) Per Page 4, 4) A), 16QAM with 50% RB is required.
- 4) Per Page 4, 4) B), 16QAM with 1RB for both channel edges are required.
- 5) Per Page 4, 4), A) I) and Page 5, 4), A), I), 100% RB Allocation is not required to be tested when the 50% RB SAR is not > 1.45 W/kg for the highest bandwidth.
- 6) The bolded configurations above were tested for SAR.

FCC ID: A3LSCH1415	 PCTEST ENGINEERING LABORATORY, INC.	SAR EVALUATION REPORT		Reviewed by: Quality Manager
Document S/N: 0Y1205290731.A3L	Test Dates: 05/31/12 - 06/19/12	DUT Type: Portable Handset		Page 31 of 61

**Table 11-9
Fixed CDMA Conducted Powers**



Band	Channel	Frequency	SO55 [dBm]	SO55 [dBm]	TDSO SO32 [dBm]	TDSO SO32 [dBm]
	F-RC	MHz	RC1	RC3	FCH+SCH	FCH
Cellular	1013	824.7	17.93	17.95	17.92	17.91
	384	836.52	18.02	18.05	18.01	18.03
	777	848.31	17.93	17.92	17.96	17.99
PCS	25	1851.25	18.21	18.31	18.31	18.32
	600	1880	18.14	18.19	18.18	18.23
	1175	1908.75	18.06	18.11	18.08	18.01

Note: There is no power reduction applied to the CDMA Voice modes, however the device with output powers represented in the table above was tuned down (for SAR Test purposes only) to analyze simultaneous SAR scenarios in the SVLTE condition where LTE is operating at maximum output power in conjunction with a lower CDMA voice level (See Table 11-1).

CDMA 1x Test Notes:

Per KDB Publication 941225 D01:

1. Head SAR was tested with SO55 RC3. SO55 RC1 was not required since the average output power was not more than 0.25 dB than the SO55 RC3 powers.
2. Body-Worn and Hotspot SAR was tested with 1x RTT with TDSO / SO32 FCH Only. TDSO / SO32 FCH+SCH SAR tests were not required since the average output power was not more than 0.25 dB higher than the TDSO / SO32 FCH only powers.

FCC ID: A3LSCH1415		SAR EVALUATION REPORT		Reviewed by: Quality Manager
Document S/N: 0Y1205290731.A3L	Test Dates: 05/31/12 - 06/19/12	DUT Type: Portable Handset		Page 32 of 61



12 SYSTEM VERIFICATION

12.1 Tissue Verification

**Table 12-1
Measured Tissue Properties**

Calibrated for Tests Performed on:	Tissue Type	Tissue Temp During Calibration (C°)	Measured Frequency (MHz)	Measured Conductivity, σ (S/m)	Measured Dielectric Constant, ϵ	TARGET Conductivity, σ (S/m)	TARGET Dielectric Constant, ϵ	% dev σ	% dev ϵ
06/12/2012	750H	21.1	725	0.876	40.79	0.89	42.03	-1.35%	-2.96%
			740	0.891	40.57	0.89	41.95	0.22%	-3.30%
			755	0.905	40.33	0.89	41.88	1.57%	-3.69%
			770	0.917	40.15	0.89	41.81	2.80%	-3.96%
			785	0.934	39.98	0.89	41.74	4.47%	-4.21%
05/31/2012	835H	24.7	820	0.886	42.28	0.90	41.57	-1.34%	1.71%
			835	0.897	42.00	0.90	41.50	-0.33%	1.20%
			850	0.909	41.99	0.92	41.50	-0.76%	1.18%
06/18/2012	835H	22.7	820	0.902	41.66	0.90	41.57	0.45%	0.21%
			835	0.920	41.47	0.90	41.50	2.22%	-0.07%
			850	0.934	41.31	0.92	41.50	1.97%	-0.46%
06/04/2012	1900H	22.6	1850	1.337	38.51	1.40	40.00	-4.50%	-3.73%
			1880	1.370	38.36	1.40	40.00	-2.14%	-4.10%
			1910	1.399	38.27	1.40	40.00	-0.07%	-4.32%
06/11/2012	1900H	23.2	1850	1.392	39.59	1.40	40.00	-0.57%	-1.02%
			1880	1.423	39.40	1.40	40.00	1.64%	-1.50%
			1910	1.452	39.26	1.40	40.00	3.71%	-1.85%
06/19/2012	2450H	23.3	2401	1.743	37.42	1.76	39.30	-0.85%	-4.78%
			2450	1.819	37.67	1.80	39.20	1.06%	-3.90%
			2499	1.890	38.09	1.85	39.14	2.05%	-2.67%
06/19/2012	5200-5800H	24.9	5200	4.623	36.44	4.66	36.00	-0.79%	1.22%
			5220	4.673	36.52	4.68	35.98	-0.15%	1.50%
			5320	4.767	36.21	4.78	35.88	-0.27%	0.92%
			5500	4.911	35.97	4.97	35.65	-1.09%	0.90%
			5700	5.114	35.63	5.17	35.40	-1.08%	0.65%
			5785	5.181	35.51	5.26	35.32	-1.41%	0.55%
			5800	5.209	35.54	5.27	35.30	-1.16%	0.68%
06/11/2012	750B	23.4	725	0.946	54.75	0.96	55.82	-1.46%	-1.91%
			740	0.958	54.60	0.96	55.73	-0.31%	-2.03%
			755	0.976	54.44	0.96	55.65	1.35%	-2.17%
			770	0.990	54.24	0.96	55.56	2.70%	-2.38%
			785	1.006	54.04	0.97	55.48	4.25%	-2.60%
05/31/2012	835B	22.9	820	0.984	53.70	0.97	55.28	1.55%	-2.87%
			835	0.997	53.66	0.97	55.20	2.78%	-2.79%
			850	1.013	53.50	0.99	55.15	2.53%	-3.00%
06/18/2012	835B	23.5	820	0.981	54.90	0.97	55.28	1.24%	-0.69%
			835	0.996	54.74	0.97	55.20	2.68%	-0.83%
			850	1.008	54.65	0.99	55.15	2.02%	-0.91%
06/05/2012	1900B	22.8	1850	1.468	52.45	1.52	53.30	-3.42%	-1.59%
			1880	1.499	52.36	1.52	53.30	-1.38%	-1.76%
			1910	1.533	52.26	1.52	53.30	0.86%	-1.95%
06/19/2012	2450B	22.7	2401	1.962	54.71	1.90	52.77	3.10%	3.69%
			2450	2.026	54.60	1.95	52.70	3.90%	3.61%
			2499	2.078	54.41	2.02	52.64	2.92%	3.37%
06/19/2012	5200-5800B	24.9	5200	5.342	48.31	5.30	49.01	0.81%	-1.44%
			5220	5.395	48.30	5.32	48.99	1.35%	-1.40%
			5320	5.541	47.92	5.44	48.61	1.88%	-1.41%
			5500	5.780	47.53	5.65	48.58	2.30%	-2.16%
			5700	6.097	46.92	5.88	48.28	3.69%	-2.81%
			5785	6.191	46.71	5.98	48.24	3.49%	-3.18%
			5800	6.233	46.71	6.00	48.20	3.88%	-3.09%

The above measured tissue parameters were used in the DASY software to perform interpolation via the DASY software to determine actual dielectric parameters at the test frequencies (per IEEE 1528 6.6.1.2). The SAR test plots may slightly differ from the table above since the DASY software rounds to three significant digits.

FCC ID: A3LSCHI415	 PCTEST ENGINEERING LABORATORY, INC.	SAR EVALUATION REPORT		Reviewed by: Quality Manager
Document S/N: 0Y1205290731.A3L	Test Dates: 05/31/12 - 06/19/12	DUT Type: Portable Handset		Page 33 of 61



Probe calibration used within ± 100 MHz of the test frequency in either 5.725 - 5.85 or 5.47-5.725 GHz is acceptable per KDB Publication 865664 since the design of the SAR probe supports the extended frequency, provided the DASY software version recommended is used for the tests, and the expanded calibration uncertainty ($k=2$) is less than or equal to 15% (See SAR probe calibration certificate for this information). The dielectric and conductivities measured are within 10% and 5% respectively of the target parameters specified in Supplement C 01-01.

12.2 Measurement Procedure for Tissue verification

- 1) The network analyzer and probe system was configured and calibrated.
- 2) The probe was immersed in the sample which was placed in a nonmetallic container. Trapped air bubbles beneath the flange were minimized by placing the probe at a slight angle.
- 3) The complex admittance with respect to the probe aperture was measured
- 4) The complex relative permittivity ϵ can be calculated from the below equation (Pournaropoulos and Misra):

$$Y = \frac{j2\omega\epsilon_r\epsilon_0}{[\ln(b/a)]^2} \int_a^b \int_a^b \int_0^\pi \cos\phi' \frac{\exp[-j\omega r(\mu_0\epsilon_r\epsilon_0)^{1/2}]}{r} d\phi' d\rho' d\rho$$

where Y is the admittance of the probe in contact with the sample, the primed and unprimed coordinates refer to source and observation points, respectively, $r^2 = \rho^2 + \rho'^2 - 2\rho\rho'\cos\phi'$, ω is the angular frequency, and $j = \sqrt{-1}$.

FCC ID: A3LSCHI415	 PCTEST ENGINEERING LABORATORY, INC.	SAR EVALUATION REPORT		Reviewed by: Quality Manager
Document S/N: 0Y1205290731.A3L	Test Dates: 05/31/12 - 06/19/12	DUT Type: Portable Handset		Page 34 of 61

12.3 Test System Verification

Prior to assessment, the system is verified to $\pm 10\%$ of the manufacturer SAR measurement on the reference dipole at the time of calibration.

Table 12-2
System Verification Results

System Verification TARGET & MEASURED											
Tissue Frequency (MHz)	Tissue Type	Date:	Amb. Temp (°C)	Liquid Temp (°C)	Input Power (W)	Dipole SN	Probe SN	Measured SAR _{1g} (W/kg)	1 W Target SAR _{1g} (W/kg)	1 W Normalized SAR _{1g} (W/kg)	Deviation (%)
750	Head	06/12/2012	21.9	21.6	0.100	1046	3561	0.815	8.400	8.150	-2.98%
835	Head	05/31/2012	24.8	23.2	0.100	4d119	3258	0.939	9.420	9.390	-0.32%
835	Head	06/18/2012	24.1	23.3	0.100	4d133	3209	0.961	9.450	9.610	1.69%
1900	Head	06/04/2012	23.9	22.1	0.100	5d149	3288	4.00	39.300	40.000	1.78%
1900	Head	06/11/2012	22.9	21.6	0.100	5d080	3022	3.91	39.900	39.100	-2.01%
2450	Head	06/19/2012	24.4	22.9	0.100	719	3258	5.36	53.800	53.600	-0.37%
5200	Head	06/19/2012	24.8	24.0	0.0158	1057	3589	1.30	79.100	82.278	4.02%
5500	Head	06/19/2012	24.6	23.9	0.0141	1057	3589	1.20	84.900	85.106	0.24%
5800	Head	06/19/2012	24.5	23.7	0.0141	1057	3589	1.07	79.500	75.887	-4.54%
750	Body	06/11/2012	22.4	21.9	0.250	1046	3561	2.07	8.800	8.280	-5.91%
835	Body	05/31/2012	23.6	22.5	0.100	4d119	3258	1.02	9.560	10.200	6.69%
835	Body	06/18/2012	24.1	23.0	0.100	4d133	3209	0.958	9.600	9.580	-0.21%
1900	Body	06/05/2012	23.3	22.4	0.100	5d149	3288	3.95	39.300	39.500	0.51%
2450	Body	06/19/2012	23.1	22.9	0.100	719	3258	5.38	51.300	53.800	4.87%
5200	Body	06/19/2012	24.5	23.8	0.0158	1057	3589	1.23	73.400	77.848	6.06%
5500	Body	06/19/2012	24.5	23.9	0.0158	1057	3589	1.30	78.900	82.278	4.28%
5800	Body	06/19/2012	24.6	23.9	0.0158	1057	3589	1.27	74.300	80.380	8.18%

Note: Per KDB Publication 865664, when a reference dipole is not defined within ± 100 MHz of the test frequency, the system verification may be conducted within ± 200 MHz of the center frequency of the measurement frequencies if the SAR probe calibration is valid and the same tissue-equivalent matter is used for verification and test measurements.

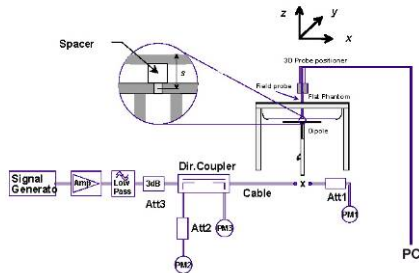

Figure 12-1
System Verification Setup Diagram



Figure 12-2
System Verification Setup Photo

FCC ID: A3LSCH1415	PCTEST ENGINEERING LABORATORY, INC.	SAR EVALUATION REPORT	SAMSUNG	Reviewed by: Quality Manager
Document S/N: 0Y1205290731.A3L	Test Dates: 05/31/12 - 06/19/12	DUT Type: Portable Handset		Page 35 of 61

13 SAR DATA SUMMARY



13.1 Standalone Head SAR Data

Table 13-1
Cell. CDMA Head SAR Results

MEASUREMENT RESULTS									
FREQUENCY		Mode/Band	Conducted Power [dBm]	Power Drift [dB]	Target Power [dBm]	Side	Test Position	Device Serial Number	SAR (1g)
MHz	Ch.								(W/kg)
836.52	384	Cell. CDMA	24.39	0.00	24.50	Right	Touch	0841-1297	0.234
836.52	384	Cell. CDMA	24.39	-0.05	24.50	Right	Tilt	0841-1297	0.171
836.52	384	Cell. CDMA	24.39	-0.01	24.50	Left	Touch	0841-1297	0.285
836.52	384	Cell. CDMA	24.39	-0.04	24.50	Left	Tilt	0841-1297	0.173
836.52	384	Cell. CDMA	18.05	-0.01	18.00	Right	Touch	0841-1300	0.058
836.52	384	Cell. CDMA	18.05	0.01	18.00	Right	Tilt	0841-1300	0.044
836.52	384	Cell. CDMA	18.05	0.00	18.00	Left	Touch	0841-1300	0.081
836.52	384	Cell. CDMA	18.05	-0.02	18.00	Left	Tilt	0841-1300	0.050
ANSI / IEEE C95.1 1992 - SAFETY LIMIT Spatial Peak Uncontrolled Exposure/General Population						Head 1.6 W/kg (mW/g) averaged over 1 gram			

Table 13-2
PCS CDMA Head SAR Results

MEASUREMENT RESULTS									
FREQUENCY		Mode/Band	Conducted Power [dBm]	Power Drift [dB]	Target Power [dBm]	Side	Test Position	Device Serial Number	SAR (1g)
MHz	Ch.								(W/kg)
1880.00	600	PCS CDMA	24.51	0.10	24.50	Right	Touch	0841-1297	0.201
1880.00	600	PCS CDMA	24.51	-0.17	24.50	Right	Tilt	0841-1297	0.054
1880.00	600	PCS CDMA	24.51	0.06	24.50	Left	Touch	0841-1297	0.101
1880.00	600	PCS CDMA	24.51	0.02	24.50	Left	Tilt	0841-1297	0.037
1880.00	600	PCS CDMA	18.19	0.08	18.00	Right	Touch	0841-1300	0.034
1880.00	600	PCS CDMA	18.19	-0.08	18.00	Right	Tilt	0841-1300	0.012
1880.00	600	PCS CDMA	18.19	-0.02	18.00	Left	Touch	0841-1300	0.021
1880.00	600	PCS CDMA	18.19	0.01	18.00	Left	Tilt	0841-1300	0.013
ANSI / IEEE C95.1 1992 - SAFETY LIMIT Spatial Peak Uncontrolled Exposure/General Population						Head 1.6 W/kg (mW/g) averaged over 1 gram			



FCC ID: A3LSCHI415	 PCTEST ENGINEERING LABORATORY, INC.	SAR EVALUATION REPORT		Reviewed by: Quality Manager
Document S/N: 0Y1205290731.A3L	Test Dates: 05/31/12 - 06/19/12	DUT Type: Portable Handset		Page 36 of 61

**Table 13-3
GSM 850 Head SAR Results**

MEASUREMENT RESULTS								
FREQUENCY		Mode	Conducted Power [dBm]	Power Drift [dB]	Side	Test Position	Device Serial Number	SAR (1g)
MHz	Ch.							(W/kg)
836.60	190	GSM 850	32.46	0.04	Right	Touch	0841-1295	0.224
836.60	190	GSM 850	32.46	0.10	Right	Tilt	0841-1295	0.125
836.60	190	GSM 850	32.46	-0.01	Left	Touch	0841-1295	0.261
836.60	190	GSM 850	32.46	0.04	Left	Tilt	0841-1295	0.137
ANSI / IEEE C95.1 1992 - SAFETY LIMIT Spatial Peak Uncontrolled Exposure/General Population					Head 1.6 W/kg (mW/g) averaged over 1 gram			

**Table 13-4
GSM 1900 Head SAR Results**

MEASUREMENT RESULTS								
FREQUENCY		Mode	Conducted Power [dBm]	Power Drift [dB]	Side	Test Position	Device Serial Number	SAR (1g)
MHz	Ch.							(W/kg)
1880.00	661	GSM 1900	30.01	-0.20	Right	Touch	0841-1299	0.148
1880.00	661	GSM 1900	30.01	-0.01	Right	Tilt	0841-1299	0.045
1880.00	661	GSM 1900	30.01	-0.13	Left	Touch	0841-1299	0.083
1880.00	661	GSM 1900	30.01	-0.12	Left	Tilt	0841-1299	0.045
ANSI / IEEE C95.1 1992 - SAFETY LIMIT Spatial Peak Uncontrolled Exposure/General Population					Head 1.6 W/kg (mW/g) averaged over 1 gram			

FCC ID: A3LSCHI415		SAR EVALUATION REPORT		Reviewed by: Quality Manager
Document S/N: 0Y1205290731.A3L	Test Dates: 05/31/12 - 06/19/12	DUT Type: Portable Handset		Page 37 of 61

**Table 13-5
LTE Band 13 Head SAR Results – Max Power**

MEASUREMENT RESULTS														
FREQUENCY		Mode	Bandwidth [MHz]	Target Power [dBm]	Conducted Power [dBm]	Power Drift [dB]	MPR [dB]	Side	Test Position	Modulation	# of RB	RB Offset	Device Serial Number	SAR (1g)
MHz	Ch.													(W/kg)
782.00	23230	LTE Band 13	10	22	22.24	-0.12	1	Right	Touch	QPSK	25	12	0841-1298	0.045
782.00	23230	LTE Band 13	10	23	22.89	0.10	0	Right	Touch	QPSK	1	0	0841-1298	0.084
782.00	23230	LTE Band 13	10	23	22.76	0.12	0	Right	Touch	QPSK	1	49	0841-1298	0.081
782.00	23230	LTE Band 13	10	21	20.91	0.16	2	Right	Touch	16 QAM	25	12	0841-1298	0.031
782.00	23230	LTE Band 13	10	22	22.08	0.15	1	Right	Touch	16 QAM	1	0	0841-1298	0.067
782.00	23230	LTE Band 13	10	22	21.96	0.15	1	Right	Touch	16 QAM	1	49	0841-1298	0.067
782.00	23230	LTE Band 13	10	22	22.24	0.21	1	Right	Tilt	QPSK	25	12	0841-1298	0.024
782.00	23230	LTE Band 13	10	23	22.89	-0.03	0	Right	Tilt	QPSK	1	0	0841-1298	0.052
782.00	23230	LTE Band 13	10	23	22.76	-0.01	0	Right	Tilt	QPSK	1	49	0841-1298	0.037
782.00	23230	LTE Band 13	10	21	20.91	0.14	2	Right	Tilt	16 QAM	25	12	0841-1298	0.016
782.00	23230	LTE Band 13	10	22	22.08	0.03	1	Right	Tilt	16 QAM	1	0	0841-1298	0.040
782.00	23230	LTE Band 13	10	22	21.96	0.09	1	Right	Tilt	16 QAM	1	49	0841-1298	0.031
782.00	23230	LTE Band 13	10	22	22.24	0.12	1	Left	Touch	QPSK	25	12	0841-1298	0.028
782.00	23230	LTE Band 13	10	23	22.89	0.19	0	Left	Touch	QPSK	1	0	0841-1298	0.054
782.00	23230	LTE Band 13	10	23	22.76	0.03	0	Left	Touch	QPSK	1	49	0841-1298	0.053
782.00	23230	LTE Band 13	10	21	20.91	0.08	2	Left	Touch	16 QAM	25	12	0841-1298	0.017
782.00	23230	LTE Band 13	10	22	22.08	0.06	1	Left	Touch	16 QAM	1	0	0841-1298	0.040
782.00	23230	LTE Band 13	10	22	21.96	0.03	1	Left	Touch	16 QAM	1	49	0841-1298	0.043
782.00	23230	LTE Band 13	10	22	22.24	0.06	1	Left	Tilt	QPSK	25	12	0841-1298	0.016
782.00	23230	LTE Band 13	10	23	22.89	-0.13	0	Left	Tilt	QPSK	1	0	0841-1298	0.036
782.00	23230	LTE Band 13	10	23	22.76	0.04	0	Left	Tilt	QPSK	1	49	0841-1298	0.027
782.00	23230	LTE Band 13	10	21	20.91	0.09	2	Left	Tilt	16 QAM	25	12	0841-1298	0.012
782.00	23230	LTE Band 13	10	22	22.08	-0.02	1	Left	Tilt	16 QAM	1	0	0841-1298	0.027
782.00	23230	LTE Band 13	10	22	21.96	0.09	1	Left	Tilt	16 QAM	1	49	0841-1298	0.022
ANSI / IEEE C95.1 1992 - SAFETY LIMIT Spatial Peak Uncontrolled Exposure/General Population									Head 1.6 W/kg (mW/g) averaged over 1 gram					





FCC ID: A3LSCH1415	 PCTEST ENGINEERING LABORATORY, INC.	SAR EVALUATION REPORT		Reviewed by: Quality Manager
Document S/N: 0Y1205290731.A3L	Test Dates: 05/31/12 - 06/19/12	DUT Type: Portable Handset		Page 38 of 61

Table 13-6
LTE Band 13 Head SAR Results – Reduce Power

MEASUREMENT RESULTS														
FREQUENCY		Mode	Bandwidth [MHz]	Target Power [dBm]	Conducted Power [dBm]	Power Drift [dB]	MPR [dB]	Side	Test Position	Modulation	# of RB	RB Offset	Device Serial Number	SAR (1g)
MHz	Ch.													(W/kg)
782.00	23230	LTE Band 13	10	19	18.98	0.09	0	Right	Touch	QPSK	25	12	0841-1300	0.011
782.00	23230	LTE Band 13	10	19	18.91	-0.09	0	Right	Touch	QPSK	1	0	0841-1300	0.014
782.00	23230	LTE Band 13	10	19	19.07	0.09	0	Right	Touch	QPSK	1	49	0841-1300	0.017
782.00	23230	LTE Band 13	10	19	19.23	-0.11	0	Right	Touch	16 QAM	25	12	0841-1300	0.012
782.00	23230	LTE Band 13	10	19	18.75	0.04	0	Right	Touch	16 QAM	1	0	0841-1300	0.012
782.00	23230	LTE Band 13	10	19	18.77	0.12	0	Right	Touch	16 QAM	1	49	0841-1300	0.015
782.00	23230	LTE Band 13	10	19	18.98	0.19	0	Right	Tilt	QPSK	25	12	0841-1300	0.017
782.00	23230	LTE Band 13	10	19	18.91	-0.05	0	Right	Tilt	QPSK	1	0	0841-1300	0.028
782.00	23230	LTE Band 13	10	19	19.07	0.02	0	Right	Tilt	QPSK	1	49	0841-1300	0.020
782.00	23230	LTE Band 13	10	19	19.23	0.21	0	Right	Tilt	16 QAM	25	12	0841-1300	0.018
782.00	23230	LTE Band 13	10	19	18.75	-0.05	0	Right	Tilt	16 QAM	1	0	0841-1300	0.029
782.00	23230	LTE Band 13	10	19	18.77	-0.06	0	Right	Tilt	16 QAM	1	49	0841-1300	0.020
782.00	23230	LTE Band 13	10	19	18.98	-0.17	0	Left	Touch	QPSK	25	12	0841-1300	0.015
782.00	23230	LTE Band 13	10	19	18.91	0.11	0	Left	Touch	QPSK	1	0	0841-1300	0.023
782.00	23230	LTE Band 13	10	19	19.07	0.06	0	Left	Touch	QPSK	1	49	0841-1300	0.025
782.00	23230	LTE Band 13	10	19	19.23	0.11	0	Left	Touch	16 QAM	25	12	0841-1300	0.015
782.00	23230	LTE Band 13	10	19	18.75	0.11	0	Left	Touch	16 QAM	1	0	0841-1300	0.024
782.00	23230	LTE Band 13	10	19	18.77	0.09	0	Left	Touch	16 QAM	1	49	0841-1300	0.025
782.00	23230	LTE Band 13	10	19	18.98	0.13	0	Left	Tilt	QPSK	25	12	0841-1300	0.011
782.00	23230	LTE Band 13	10	19	18.91	0.08	0	Left	Tilt	QPSK	1	0	0841-1300	0.021
782.00	23230	LTE Band 13	10	19	19.07	0.03	0	Left	Tilt	QPSK	1	49	0841-1300	0.013
782.00	23230	LTE Band 13	10	19	19.23	0.07	0	Left	Tilt	16 QAM	25	12	0841-1300	0.015
782.00	23230	LTE Band 13	10	19	18.75	0.08	0	Left	Tilt	16 QAM	1	0	0841-1300	0.024
782.00	23230	LTE Band 13	10	19	18.77	0.05	0	Left	Tilt	16 QAM	1	49	0841-1300	0.014
ANSI / IEEE C95.1 1992 - SAFETY LIMIT Spatial Peak Uncontrolled Exposure/General Population								Head 1.6 W/kg (mW/g) averaged over 1 gram						

Table 13-7
2.4 GHz WLAN Head SAR Results

MEASUREMENT RESULTS										
FREQUENCY		Mode	Service	Conducted Power [dBm]	Power Drift [dB]	Side	Test Position	Device Serial Number	Data Rate (Mbps)	SAR (1g)
MHz	Ch.									(W/kg)
2412	1	IEEE 802.11b	DSSS	16.45	-0.18	Right	Touch	0841-1295	1	0.041
2412	1	IEEE 802.11b	DSSS	16.45	0.00	Right	Tilt	0841-1295	1	0.052
2412	1	IEEE 802.11b	DSSS	16.45	-0.14	Left	Touch	0841-1295	1	0.058
2412	1	IEEE 802.11b	DSSS	16.45	0.08	Left	Tilt	0841-1295	1	0.066
ANSI / IEEE C95.1 1992 - SAFETY LIMIT Spatial Peak Uncontrolled Exposure/General Population						Head 1.6 W/kg (mW/g) averaged over 1 gram				

FCC ID: A3LSCH1415	 PCTEST ENGINEERING LABORATORY, INC.	SAR EVALUATION REPORT		Reviewed by: Quality Manager
Document S/N: 0Y1205290731.A3L	Test Dates: 05/31/12 - 06/19/12	DUT Type: Portable Handset		Page 39 of 61

**Table 13-8
5 GHz WLAN Head SAR Results**



MEASUREMENT RESULTS										
FREQUENCY		Mode	Service	Conducted Power [dBm]	Power Drift [dB]	Side	Test Position	Device Serial Number	Data Rate (Mbps)	SAR (1g)
MHz	Ch.									(W/kg)
5785	157	IEEE 802.11a	OFDM	12.81	0.18	Right	Touch	0841-1295	6	0.027
5785	157	IEEE 802.11a	OFDM	12.81	0.14	Right	Tilt	0841-1295	6	0.008
5785	157	IEEE 802.11a	OFDM	12.81	0.02	Left	Touch	0841-1295	6	0.082
5785	157	IEEE 802.11a	OFDM	12.81	0.00	Left	Tilt	0841-1295	6	0.001
5220	44	IEEE 802.11a	OFDM	12.18	0.00	Right	Touch	0841-1295	6	0.024
5220	44	IEEE 802.11a	OFDM	12.18	0.00	Right	Tilt	0841-1295	6	0.001
5220	44	IEEE 802.11a	OFDM	12.18	-0.14	Left	Touch	0841-1295	6	0.003
5220	44	IEEE 802.11a	OFDM	12.18	0.00	Left	Tilt	0841-1295	6	0.000
5320	64	IEEE 802.11a	OFDM	12.73	0.18	Right	Touch	0841-1295	6	0.031
5320	64	IEEE 802.11a	OFDM	12.73	0.00	Right	Tilt	0841-1295	6	0.002
5320	64	IEEE 802.11a	OFDM	12.73	-0.04	Left	Touch	0841-1295	6	0.056
5320	64	IEEE 802.11a	OFDM	12.73	0.16	Left	Tilt	0841-1295	6	0.000
5700	140	IEEE 802.11a	OFDM	12.75	0.00	Right	Touch	0841-1295	6	0.033
5700	140	IEEE 802.11a	OFDM	12.75	0.00	Right	Tilt	0841-1295	6	0.004
5700	140	IEEE 802.11a	OFDM	12.75	0.01	Left	Touch	0841-1295	6	0.049
5700	140	IEEE 802.11a	OFDM	12.75	0.16	Left	Tilt	0841-1295	6	0.002
ANSI / IEEE C95.1 1992 - SAFETY LIMIT Spatial Peak Uncontrolled Exposure/General Population						Head 1.6 W/kg (mW/g) averaged over 1 gram				

13.2 Standalone Body-Worn SAR Data

**Table 13-9
CDMA Body-Worn SAR Results**

MEASUREMENT RESULTS										
FREQUENCY		Mode	Service	Conducted Power [dBm]	Power Drift [dB]	Target Power [dBm]	Spacing	Device Serial Number	Side	SAR (1g)
MHz	Ch.									(W/kg)
836.52	384	Cell. CDMA	TDSO / SO32	24.33	0.00	24.50	1.0 cm	0841-1297	back	0.589
836.52	384	Cell. CDMA	TDSO / SO32	18.03	-0.03	18.00	1.0 cm	0841-1300	back	0.174
1880.00	600	PCS CDMA	TDSO / SO32	24.55	-0.03	24.50	1.0 cm	0841-1297	back	0.501
1880.00	600	PCS CDMA	TDSO / SO32	18.23	-0.03	18.00	1.0 cm	0841-1300	back	0.110
ANSI / IEEE C95.1 1992 - SAFETY LIMIT Spatial Peak Uncontrolled Exposure/General Population						Body 1.6 W/kg (mW/g) averaged over 1 gram				

Note: For CDMA 1x mode, hotspot back side SAR Data was used for supporting body-worn accessory compliance per FCC KDB Publication 941225 D06. CDMA 1x-RTT SAR was required to be evaluated for Hotspot exposure conditions to support simultaneous capabilities per Table 1-2.

FCC ID: A3LSCH1415	 PCTEST ENGINEERING LABORATORY, INC.	SAR EVALUATION REPORT		Reviewed by: Quality Manager
Document S/N: 0Y1205290731.A3L	Test Dates: 05/31/12 - 06/19/12	DUT Type: Portable Handset		Page 40 of 61

**Table 13-10
GSM/GPRS Body-Worn SAR Results**

MEASUREMENT RESULTS										
FREQUENCY		Mode	Service	Conducted Power [dBm]	Power Drift [dB]	Spacing	Device Serial Number	# of Time Slots	Side	SAR (1g)
MHz	Ch.									(W/kg)
836.60	190	GSM 850	GSM	32.46	-0.02	1.0 cm	0841-1295	1	back	0.576
836.60	190	GSM 850	GPRS	29.93	-0.12	1.0 cm	0841-1295	2	back	0.762
1880.00	661	GSM 1900	GSM	30.01	-0.05	1.0 cm	0841-1299	1	back	0.469
1880.00	661	GSM 1900	GPRS	28.80	-0.06	1.0 cm	0841-1299	2	back	0.783
ANSI / IEEE C95.1 1992 - SAFETY LIMIT Spatial Peak Uncontrolled Exposure/General Population						Body 1.6 W/kg (mW/g) averaged over 1 gram				

Note: For GPRS modes, Hotspot SAR Data was used for supporting body-worn accessory compliance per FCC KDB Publication 941225 D06.

**Table 13-11
LTE Body-Worn SAR Results**



MEASUREMENT RESULTS														
FREQUENCY		Mode	Bandwidth [MHz]	Target Power [dBm]	Conducted Power [dBm]	Power Drift [dB]	MPR [dB]	Device Serial Number	Modulation	# of RB	RB Offset	Spacing	Side	SAR (1g)
MHz	Ch.													(W/kg)
782.00	23230	LTE Band 13	10	22	22.24	-0.02	1	0841-1298	QPSK	25	12	1.0 cm	back	0.121
782.00	23230	LTE Band 13	10	23	22.89	-0.07	0	0841-1298	QPSK	1	0	1.0 cm	back	0.192
782.00	23230	LTE Band 13	10	23	22.76	0.03	0	0841-1298	QPSK	1	49	1.0 cm	back	0.228
782.00	23230	LTE Band 13	10	21	20.91	0.08	2	0841-1298	16 QAM	25	12	1.0 cm	back	0.087
782.00	23230	LTE Band 13	10	22	22.08	0.11	1	0841-1298	16 QAM	1	0	1.0 cm	back	0.155
782.00	23230	LTE Band 13	10	22	21.96	0.00	1	0841-1298	16 QAM	1	49	1.0 cm	back	0.192
782.00	23230	LTE Band 13	10	19	18.98	-0.05	0	0841-1300	QPSK	25	12	1.0 cm	back	0.052
782.00	23230	LTE Band 13	10	19	18.91	-0.12	0	0841-1300	QPSK	1	0	1.0 cm	back	0.064
782.00	23230	LTE Band 13	10	19	19.07	-0.05	0	0841-1300	QPSK	1	49	1.0 cm	back	0.088
782.00	23230	LTE Band 13	10	19	19.23	0.02	0	0841-1300	16 QAM	25	12	1.0 cm	back	0.053
782.00	23230	LTE Band 13	10	19	18.75	-0.15	0	0841-1300	16 QAM	1	0	1.0 cm	back	0.064
782.00	23230	LTE Band 13	10	19	18.77	-0.05	0	0841-1300	16 QAM	1	49	1.0 cm	back	0.080
ANSI / IEEE C95.1 1992 - SAFETY LIMIT Spatial Peak Uncontrolled Exposure/General Population								Body 1.6 W/kg (mW/g) averaged over 1 gram						

Note: For LTE Mode, Hotspot SAR Data was used for supporting body-worn accessory compliance per FCC KDB Publication 941225 D06.

**Table 13-12
WLAN Body-Worn SAR Results**

MEASUREMENT RESULTS										
FREQUENCY		Mode	Service	Conducted Power [dBm]	Power Drift [dB]	Spacing	Device Serial Number	Data Rate (Mbps)	Side	SAR (1g)
MHz	Ch.									(W/kg)
2412	1	IEEE 802.11b	DSSS	16.45	0.10	1.0 cm	0841-1295	1	back	0.116
5785	157	IEEE 802.11a	OFDM	12.81	0.10	1.0 cm	0841-1295	6	back	0.001
5220	44	IEEE 802.11a	OFDM	12.18	0.00	1.0 cm	0841-1295	6	back	0.000
5320	64	IEEE 802.11a	OFDM	12.73	-0.15	1.0 cm	0841-1295	6	back	0.000
5700	140	IEEE 802.11a	OFDM	12.75	0.10	1.0 cm	0841-1295	6	back	0.005
ANSI / IEEE C95.1 1992 - SAFETY LIMIT Spatial Peak Uncontrolled Exposure/General Population						Body 1.6 W/kg (mW/g) averaged over 1 gram				



Note: For IEEE 802.11b mode, Hotspot SAR Data was used for supporting body-worn accessory compliance per FCC KDB Publication 941225 D06.

FCC ID: A3LSCH1415		SAR EVALUATION REPORT		Reviewed by: Quality Manager
Document S/N: 0Y1205290731.A3L	Test Dates: 05/31/12 - 06/19/12	DUT Type: Portable Handset	Page 41 of 61	

13.3 Standalone Wireless Router SAR Data

Table 13-13
CDMA/EVDO Hotspot SAR Data

MEASUREMENT RESULTS											
FREQUENCY		Mode	Service	Conducted Power [dBm]	Power Drift [dB]	Target Power [dBm]	Position	Spacing	Device Serial Number	Side	SAR (1g)
MHz	Ch.										(W/kg)
836.52	384	Cell. CDMA	TDSO / SO32	24.33	0.00	24.50	Body	1.0 cm	0841-1297	back	0.589
836.52	384	Cell. CDMA	TDSO / SO32	24.33	-0.03	24.50	Body	1.0 cm	0841-1297	front	0.307
836.52	384	Cell. CDMA	TDSO / SO32	24.33	0.17	24.50	Body	1.0 cm	0841-1297	bottom	0.153
836.52	384	Cell. CDMA	TDSO / SO32	24.33	0.05	24.50	Body	1.0 cm	0841-1297	left	0.526
836.52	384	Cell. CDMA	TDSO / SO32	18.03	-0.03	18.00	Body	1.0 cm	0841-1300	back	0.174
836.52	384	Cell. CDMA	TDSO / SO32	18.03	-0.02	18.00	Body	1.0 cm	0841-1300	front	0.077
836.52	384	Cell. CDMA	TDSO / SO32	18.03	0.02	18.00	Body	1.0 cm	0841-1300	bottom	0.031
836.52	384	Cell. CDMA	TDSO / SO32	18.03	0.04	18.00	Body	1.0 cm	0841-1300	left	0.120
836.52	384	Cell. CDMA	EVDO Rev. 0	24.32	-0.06	24.50	Body	1.0 cm	0841-1297	back	0.693
836.52	384	Cell. CDMA	EVDO Rev. 0	24.32	0.01	24.50	Body	1.0 cm	0841-1297	front	0.297
836.52	384	Cell. CDMA	EVDO Rev. 0	24.32	0.18	24.50	Body	1.0 cm	0841-1297	bottom	0.150
836.52	384	Cell. CDMA	EVDO Rev. 0	24.32	0.00	24.50	Body	1.0 cm	0841-1297	left	0.499
1880.00	600	PCS CDMA	TDSO / SO32	24.55	-0.03	24.50	Body	1.0 cm	0841-1297	back	0.501
1880.00	600	PCS CDMA	TDSO / SO32	24.55	-0.09	24.50	Body	1.0 cm	0841-1297	front	0.259
1880.00	600	PCS CDMA	TDSO / SO32	24.55	0.03	24.50	Body	1.0 cm	0841-1297	bottom	0.420
1880.00	600	PCS CDMA	TDSO / SO32	24.55	-0.05	24.50	Body	1.0 cm	0841-1297	left	0.187
1880.00	600	PCS CDMA	TDSO / SO32	18.23	-0.03	18.00	Body	1.0 cm	0841-1300	back	0.110
1880.00	600	PCS CDMA	TDSO / SO32	18.23	0.08	18.00	Body	1.0 cm	0841-1300	front	0.048
1880.00	600	PCS CDMA	TDSO / SO32	18.23	0.14	18.00	Body	1.0 cm	0841-1300	bottom	0.092
1880.00	600	PCS CDMA	TDSO / SO32	18.23	-0.01	18.00	Body	1.0 cm	0841-1300	left	0.034
1880.00	600	PCS CDMA	EVDO Rev. 0	24.49	-0.01	24.50	Body	1.0 cm	0841-1297	back	0.573
1880.00	600	PCS CDMA	EVDO Rev. 0	24.49	-0.03	24.50	Body	1.0 cm	0841-1297	front	0.270
1880.00	600	PCS CDMA	EVDO Rev. 0	24.49	0.09	24.50	Body	1.0 cm	0841-1297	bottom	0.402
1880.00	600	PCS CDMA	EVDO Rev. 0	24.49	-0.08	24.50	Body	1.0 cm	0841-1297	left	0.199
ANSI / IEEE C95.1 1992 - SAFETY LIMIT								Body			
Spatial Peak								1.6 W/kg (mW/g)			
Uncontrolled Exposure/General Population								averaged over 1 gram			

FCC ID: A3LSCH1415	 PCTEST ENGINEERING LABORATORY, INC.	SAR EVALUATION REPORT		Reviewed by: Quality Manager
Document S/N: 0Y1205290731.A3L	Test Dates: 05/31/12 - 06/19/12	DUT Type: Portable Handset		Page 42 of 61

**Table 13-14
GPRS Hotspot SAR Data**

MEASUREMENT RESULTS											
FREQUENCY		Mode	Service	Conducted Power [dBm]	Power Drift [dB]	Position	Spacing	Device Serial Number	# of GPRS Slots	Side	SAR (1g)
MHz	Ch.										(W/kg)
836.60	190	GSM 850	GPRS	29.93	-0.12	Body	1.0 cm	0841-1295	2	back	0.762
836.60	190	GSM 850	GPRS	29.93	-0.09	Body	1.0 cm	0841-1295	2	front	0.368
836.60	190	GSM 850	GPRS	29.93	0.18	Body	1.0 cm	0841-1295	2	bottom	0.148
836.60	190	GSM 850	GPRS	29.93	-0.05	Body	1.0 cm	0841-1295	2	left	0.507
1880.00	661	GSM 1900	GPRS	28.80	-0.06	Body	1.0 cm	0841-1299	2	back	0.783
1880.00	661	GSM 1900	GPRS	28.80	-0.02	Body	1.0 cm	0841-1299	2	front	0.383
1880.00	661	GSM 1900	GPRS	28.80	-0.01	Body	1.0 cm	0841-1299	2	bottom	0.522
1880.00	661	GSM 1900	GPRS	28.80	-0.08	Body	1.0 cm	0841-1299	2	left	0.224
ANSI / IEEE C95.1 1992 - SAFETY LIMIT							Body				
Spatial Peak							1.6 W/kg (mW/g)				
Uncontrolled Exposure/General Population							averaged over 1 gram				



FCC ID: A3LSCH1415	 PCTEST ENGINEERING LABORATORY, INC.	SAR EVALUATION REPORT		Reviewed by: Quality Manager
Document S/N: 0Y1205290731.A3L	Test Dates: 05/31/12 - 06/19/12	DUT Type: Portable Handset		Page 43 of 61

Table 13-15
LTE Band 13 Hotspot SAR Data – Max Power

MEASUREMENT RESULTS														
FREQUENCY		Mode	Bandwidth [MHz]	Target Power [dBm]	Conducted Power [dBm]	Power Drift [dB]	MPR [dB]	Device Serial Number	Modulation	# of RB	RB Offset	Spacing	Side	SAR (1g)
MHz	Ch.													(W/kg)
782.00	23230	LTE Band 13	10	22	22.24	-0.02	1	0841-1298	QPSK	25	12	1.0 cm	back	0.121
782.00	23230	LTE Band 13	10	23	22.89	-0.07	0	0841-1298	QPSK	1	0	1.0 cm	back	0.192
782.00	23230	LTE Band 13	10	23	22.76	0.03	0	0841-1298	QPSK	1	49	1.0 cm	back	0.228
782.00	23230	LTE Band 13	10	21	20.91	0.08	2	0841-1298	16 QAM	25	12	1.0 cm	back	0.087
782.00	23230	LTE Band 13	10	22	22.08	0.11	1	0841-1298	16 QAM	1	0	1.0 cm	back	0.155
782.00	23230	LTE Band 13	10	22	21.96	0.00	1	0841-1298	16 QAM	1	49	1.0 cm	back	0.192
782.00	23230	LTE Band 13	10	22	22.24	0.08	1	0841-1298	QPSK	25	12	1.0 cm	front	0.031
782.00	23230	LTE Band 13	10	23	22.89	0.00	0	0841-1298	QPSK	1	0	1.0 cm	front	0.053
782.00	23230	LTE Band 13	10	23	22.76	-0.01	0	0841-1298	QPSK	1	49	1.0 cm	front	0.060
782.00	23230	LTE Band 13	10	21	20.91	-0.07	2	0841-1298	16 QAM	25	12	1.0 cm	front	0.022
782.00	23230	LTE Band 13	10	22	22.08	-0.02	1	0841-1298	16 QAM	1	0	1.0 cm	front	0.043
782.00	23230	LTE Band 13	10	22	21.96	0.09	1	0841-1298	16 QAM	1	49	1.0 cm	front	0.051
782.00	23230	LTE Band 13	10	22	22.24	-0.08	1	0841-1298	QPSK	25	12	1.0 cm	bottom	0.048
782.00	23230	LTE Band 13	10	23	22.89	-0.16	0	0841-1298	QPSK	1	0	1.0 cm	bottom	0.092
782.00	23230	LTE Band 13	10	23	22.76	0.06	0	0841-1298	QPSK	1	49	1.0 cm	bottom	0.102
782.00	23230	LTE Band 13	10	21	20.91	0.01	2	0841-1298	16 QAM	25	12	1.0 cm	bottom	0.039
782.00	23230	LTE Band 13	10	22	22.08	-0.01	1	0841-1298	16 QAM	1	0	1.0 cm	bottom	0.075
782.00	23230	LTE Band 13	10	22	21.96	-0.02	1	0841-1298	16 QAM	1	49	1.0 cm	bottom	0.087
782.00	23230	LTE Band 13	10	22	22.24	0.12	1	0841-1298	QPSK	25	12	1.0 cm	right	0.073
782.00	23230	LTE Band 13	10	23	22.89	0.02	0	0841-1298	QPSK	1	0	1.0 cm	right	0.131
782.00	23230	LTE Band 13	10	23	22.76	-0.11	0	0841-1298	QPSK	1	49	1.0 cm	right	0.131
782.00	23230	LTE Band 13	10	21	20.91	0.04	2	0841-1298	16 QAM	25	12	1.0 cm	right	0.055
782.00	23230	LTE Band 13	10	22	22.08	-0.14	1	0841-1298	16 QAM	1	0	1.0 cm	right	0.123
782.00	23230	LTE Band 13	10	22	21.96	0.02	1	0841-1298	16 QAM	1	49	1.0 cm	right	0.104
ANSI / IEEE C95.1 1992 - SAFETY LIMIT								Body						
Spatial Peak								1.6 W/kg (mW/g)						
Uncontrolled Exposure/General Population								averaged over 1 gram						





FCC ID: A3LSCHI415	 PCTEST ENGINEERING LABORATORY, INC.	SAR EVALUATION REPORT		Reviewed by: Quality Manager
Document S/N: 0Y1205290731.A3L	Test Dates: 05/31/12 - 06/19/12	DUT Type: Portable Handset		Page 44 of 61

Table 13-16
LTE Band 13 Hotspot SAR Data – Reduced Power

MEASUREMENT RESULTS														
FREQUENCY		Mode	Bandwidth [MHz]	Target Power [dBm]	Conducted Power [dBm]	Power Drift [dB]	MPR [dB]	Device Serial Number	Modulation	# of RB	RB Offset	Spacing	Side	SAR (1g)
MHz	Ch.													(W/kg)
782.00	23230	LTE Band 13	10	19	18.98	-0.05	0	0841-1300	QPSK	25	12	1.0 cm	back	0.052
782.00	23230	LTE Band 13	10	19	18.91	-0.12	0	0841-1300	QPSK	1	0	1.0 cm	back	0.064
782.00	23230	LTE Band 13	10	19	19.07	-0.05	0	0841-1300	QPSK	1	49	1.0 cm	back	0.088
782.00	23230	LTE Band 13	10	19	19.23	0.02	0	0841-1300	16 QAM	25	12	1.0 cm	back	0.053
782.00	23230	LTE Band 13	10	19	18.75	-0.15	0	0841-1300	16 QAM	1	0	1.0 cm	back	0.064
782.00	23230	LTE Band 13	10	19	18.77	-0.05	0	0841-1300	16 QAM	1	49	1.0 cm	back	0.080
782.00	23230	LTE Band 13	10	19	18.98	-0.10	0	0841-1300	QPSK	25	12	1.0 cm	front	0.019
782.00	23230	LTE Band 13	10	19	18.91	0.14	0	0841-1300	QPSK	1	0	1.0 cm	front	0.030
782.00	23230	LTE Band 13	10	19	19.07	0.07	0	0841-1300	QPSK	1	49	1.0 cm	front	0.024
782.00	23230	LTE Band 13	10	19	19.23	0.09	0	0841-1300	16 QAM	25	12	1.0 cm	front	0.027
782.00	23230	LTE Band 13	10	19	18.75	0.11	0	0841-1300	16 QAM	1	0	1.0 cm	front	0.033
782.00	23230	LTE Band 13	10	19	18.77	0.05	0	0841-1300	16 QAM	1	49	1.0 cm	front	0.036
782.00	23230	LTE Band 13	10	19	18.98	0.09	0	0841-1300	QPSK	25	12	1.0 cm	bottom	0.027
782.00	23230	LTE Band 13	10	19	18.91	0.06	0	0841-1300	QPSK	1	0	1.0 cm	bottom	0.036
782.00	23230	LTE Band 13	10	19	19.07	0.06	0	0841-1300	QPSK	1	49	1.0 cm	bottom	0.039
782.00	23230	LTE Band 13	10	19	19.23	0.08	0	0841-1300	16 QAM	25	12	1.0 cm	bottom	0.027
782.00	23230	LTE Band 13	10	19	18.75	-0.05	0	0841-1300	16 QAM	1	0	1.0 cm	bottom	0.035
782.00	23230	LTE Band 13	10	19	18.77	-0.03	0	0841-1300	16 QAM	1	49	1.0 cm	bottom	0.039
782.00	23230	LTE Band 13	10	19	18.98	-0.03	0	0841-1300	QPSK	25	12	1.0 cm	right	0.044
782.00	23230	LTE Band 13	10	19	18.91	0.11	0	0841-1300	QPSK	1	0	1.0 cm	right	0.067
782.00	23230	LTE Band 13	10	19	19.07	0.08	0	0841-1300	QPSK	1	49	1.0 cm	right	0.055
782.00	23230	LTE Band 13	10	19	19.23	0.01	0	0841-1300	16 QAM	25	12	1.0 cm	right	0.044
782.00	23230	LTE Band 13	10	19	18.75	-0.11	0	0841-1300	16 QAM	1	0	1.0 cm	right	0.065
782.00	23230	LTE Band 13	10	19	18.77	0.04	0	0841-1300	16 QAM	1	49	1.0 cm	right	0.052
ANSI / IEEE C95.1 1992 - SAFETY LIMIT Spatial Peak Uncontrolled Exposure/General Population								Body 1.6 W/kg (mW/g) averaged over 1 gram						

Table 13-17
WLAN Hotspot SAR Data

MEASUREMENT RESULTS										
FREQUENCY		Mode	Service	Conducted Power [dBm]	Power Drift [dB]	Spacing	Device Serial Number	Data Rate (Mbps)	Side	SAR (1g)
MHz	Ch.									(W/kg)
2412	1	IEEE 802.11b	DSSS	16.45	0.10	1.0 cm	0841-1295	1	back	0.116
2412	1	IEEE 802.11b	DSSS	16.45	-0.03	1.0 cm	0841-1295	1	front	0.036
2412	1	IEEE 802.11b	DSSS	16.45	-0.03	1.0 cm	0841-1295	1	left	0.110
ANSI / IEEE C95.1 1992 - SAFETY LIMIT Spatial Peak Uncontrolled Exposure/General Population						Body 1.6 W/kg (mW/g) averaged over 1 gram				

FCC ID: A3LSCH1415	 PCTEST ENGINEERING LABORATORY, INC.	SAR EVALUATION REPORT		Reviewed by: Quality Manager
Document S/N: 0Y1205290731.A3L	Test Dates: 05/31/12 - 06/19/12	DUT Type: Portable Handset		Page 45 of 61

13.4 SAR Test Notes

General Notes:



1. The test data reported are the worst-case SAR value with the position set in a typical configuration. Test procedures used were according to FCC/OET Bulletin 65, Supplement C [June 2001].
2. Batteries are fully charged for all readings. The standard battery was used.
3. Tissue parameters and temperatures are listed on the SAR plots.
4. Liquid tissue depth was at least 15.0 cm. To confirm the proper SAR liquid depth, the z-axis plots from the system verifications were included since the system verifications were performed using the same liquid, probe and DAE as the SAR tests in the same time period.
5. The manufacturer has confirmed that the device(s) tested have the same physical, mechanical and thermal characteristics and are within operational tolerances expected for production units..
6. Per FCC/OET Bulletin 65 Supplement C and Public Notice DA-02-1438, if the SAR measured at the middle channel for each test configuration is at least 3.0 dB lower than the SAR limit, testing at the high and low channels is optional for such test configuration(s).
7. Device was tested using a fixed spacing for body-worn accessory testing. A separation distance of 10 mm was considered because the manufacturer has determined that there will be body-worn accessories available in the marketplace for users to support this separation distance.
8. This DUT has NFC operations. The NFC antenna is integrated into the standard battery and will be the only battery available from the manufacturer for this model. Therefore all SAR tests were performed with the standard battery which already integrates the NFC antenna. The device restricts the battery used to battery model: **EB-L1K61LZ**.

GSM Test Notes:

1. Body-Worn accessory testing is typically associated with voice operations. Therefore, GSM voice was evaluated for body-worn SAR using headphones.
2. Per FCC guidance, GPRS Data Mode is additionally required for body-worn configuration. Per KDB 941225 D06, when the same wireless modes and device transmission configurations are required for body-worn accessories and hotspot mode, it is not necessary to additionally test body-worn accessory SAR for the same device orientation. Therefore, the hotspot data for the back side configurations additionally shows body-worn compliance at the same distance.
3. Justification for reduced test configurations per KDB Publication 941225 D03: The source-based time-averaged output power was evaluated for all multi-slot operations. The worse-case was evaluated for SAR.

CDMA Notes:

1. Head SAR for CDMA2000 mode was tested under RC3/SO55 per KDB Publication 941225 D01.
2. Body-Worn SAR was tested with 1x RTT with TDSO / SO32 FCH Only. TDSO / SO32 FCH+SCH SAR tests were not required since the average output power was not more than 0.25 dB higher than the TDSO / SO32 FCH only powers.
3. According to FCC KDB 941225 D01 publication, EVDO SAR (Hotspot) is measured using Subtype 0/1 Physical Layer configurations for Rev. 0. When the maximum output power of Rev. A for each channel is greater than the Rev.0 power, Rev. A must additionally be tested using the highest output channel for the configuration that resulted in the highest SAR for Rev.0. CDMA 1x-RTT SAR was required to be evaluated for Hotspot exposure conditions to support simultaneous capabilities per Table 1-2.
4. Per FCC KDB Publication 941225 D06, when the same wireless modes and device transmission configurations are required for body-worn accessories and hotspot mode, it is not necessary to additionally test body-worn accessory SAR for the same device orientation. Therefore, the CDMA 1x RTT hotspot data for the back side configuration additionally shows body-worn compliance at the same distance.

FCC ID: A3LSCHI415	 PCTEST ENGINEERING LABORATORY, INC.	SAR EVALUATION REPORT		Reviewed by: Quality Manager
Document S/N: 0Y1205290731.A3L	Test Dates: 05/31/12 - 06/19/12	DUT Type: Portable Handset		Page 46 of 61

LTE Notes:



1. LTE Considerations: LTE test configurations are determined according to SAR Test Considerations for LTE handsets and Data Modems KDB 941225 D05 Publication and were evaluated independently for each position. General test procedures can be found in Section 9.3.3.
2. MPR is implemented for this device by the manufacturer when the transmit power is not limited by the power reduction mechanism. The specific manufacturer target MPR is indicated alongside the SAR results. MPR is enabled for this device, according to 3GPP TS36.101 Section 6.2.3 – 6.2.5 under Table 6.2.3-1.
3. A-MPR was disabled for all SAR tests by setting NS=01 on the base station simulator.
4. Per FCC KDB Publication 941225 D06, when the same wireless modes and device transmission configurations are required for body-worn accessories and hotspot mode, it is not necessary to additionally test body-worn accessory SAR for the same device orientation. Therefore, the hotspot data for the back side configuration additionally shows body-worn compliance at the same distance.

WLAN Notes:

1. Justification for reduced test configurations for WIFI channels per KDB Publication 248227 and April 2010 FCC/TCB Meeting Notes for 2.4 GHz WIFI: Highest average RF output power channel for the lowest data rate was selected for SAR evaluation in 802.11b. Other IEEE 802.11 modes (including 802.11g/n) were not investigated since the average output powers over all channels and data rates were not more than 0.25 dB higher than the tested channel in the lowest data rate of IEEE 802.11b mode.
2. Justification for reduced test configurations for WIFI channels per KDB Publication 248227 and April 2010 FCC/TCB Meeting Notes for 5 GHz WIFI: Highest average RF output power channel for the lowest data rate was selected for SAR evaluation in 802.11a. Other IEEE 802.11 modes (including 802.11n 20 MHz and 40 MHz Bandwidth) were not investigated since the average output powers over all channels and data rates were not more than 0.25 dB higher than the tested channel in the lowest data rate of IEEE 802.11a mode.
3. WLAN transmission was verified using an uncalibrated spectrum analyzer.
4. When the maximum extrapolated peak SAR of the zoom scan for the maximum output channel is <1.6 W/kg and the 1g averaged SAR is <0.8 W/kg, SAR testing on other channels is not required. Otherwise, the other default (or corresponding required) test channels were additionally tested using the lowest data rate.
5. Per FCC KDB Publication 941225 D06, when the same wireless modes and device transmission configurations are required for body-worn accessories and hotspot mode, it is not necessary to additionally test body-worn accessory SAR for the same device orientation. Therefore, the 2.4 GHz WLAN hotspot data for the back side configuration additionally shows body-worn compliance at the same distance.

Hotspot Notes:

1. Top and Right Edges for the CDMA/EVDO/GSM/GPRS/EDGE transmitter were not tested since the antenna distance from the edge was greater than 2.5 cm per FCC KDB Publication 941225 D06 guidance (see Section 1.3).
2. Top and Left Edges for the LTE transmitter were not tested since the antenna distance from the edge was greater than 2.5 cm per FCC KDB Publication 941225 D06 (see Section 1.3).
3. Top, Bottom, and Right Edges for the WLAN transmitter were not tested since the antenna distance from the edge was greater than 2.5 cm per FCC KDB Publication 941225 D06 (see Section 1.3).
4. During SAR Testing for the Wireless Router conditions per KDB 941225 D06, the actual Portable Hotspot operation (with actual simultaneous transmission of a transmitter with WIFI) was not activated (See Section 7.6.)

FCC ID: A3LSCHI415		SAR EVALUATION REPORT		Reviewed by: Quality Manager
Document S/N: 0Y1205290731.A3L	Test Dates: 05/31/12 - 06/19/12	DUT Type: Portable Handset	Page 47 of 61	

14 FCC MULTI-TX AND ANTENNA SAR CONSIDERATIONS

14.1 Introduction

The following procedures adopted from “FCC SAR Considerations for Cell Phones with Multiple Transmitters” FCC KDB Publication 648474 are applicable to handsets with built-in unlicensed transmitters such as 802.11a/b/g/n and Bluetooth devices which may simultaneously transmit with the licensed transmitter.

14.2 FCC Power Tables & Conditions



	2.45	5.15 - 5.35	5.47 - 5.85	GHz
P_{Ref}	12	6	5	mW

Device output power should be rounded to the nearest mW to compare with values specified in this table.

Figure 14-1
Output Power Thresholds for Unlicensed Transmitters

	Individual Transmitter	Simultaneous Transmission
Licensed Transmitters	<u>Routine evaluation required</u>	SAR not required: <u>Unlicensed only</u>
Unlicensed Transmitters	<p><u>When there is no simultaneous transmission –</u></p> <ul style="list-style-type: none"> output ≤ 60/f: SAR not required output > 60/f: stand-alone SAR required <p><u>When there is simultaneous transmission –</u> <u>Stand-alone SAR not required when</u></p> <ul style="list-style-type: none"> output $\leq 2 \cdot P_{Ref}$ and antenna is ≥ 5.0 cm from other antennas output $\leq P_{Ref}$ and antenna is ≥ 2.5 cm from other antennas output $\leq P_{Ref}$ and antenna is < 2.5 cm from other antennas, each with either output power $\leq P_{Ref}$ or 1-g SAR < 1.2 W/kg <p><u>Otherwise stand-alone SAR is required</u></p> <p><u>When stand-alone SAR is required</u></p> <ul style="list-style-type: none"> test SAR on highest output channel for each wireless mode and exposure condition if SAR for highest output channel is $> 50\%$ of SAR limit, evaluate all channels according to normal procedures 	<p><u>Licensed & Unlicensed</u></p> <ul style="list-style-type: none"> when stand-alone 1-g SAR is not required and antenna is ≥ 5 cm from other antennas when the sum of the 1-g SAR is < 1.6 W/kg for all simultaneous transmitting antennas when SAR to peak location separation ratio of simultaneous transmitting antenna pair is < 0.3 <p>SAR required: <u>Licensed & Unlicensed</u></p> <p>antenna pairs with SAR to peak location separation ratio ≥ 0.3; test is only required for the configuration that results in the highest SAR in stand-alone configuration for each wireless mode and exposure condition</p> <p>Note: simultaneous transmission exposure conditions for head and body can be different for different style phones; therefore, different test requirements may apply</p>

Figure 14-2
SAR Evaluation Requirements for Multiple Transmitter Handsets

FCC ID: A3LSCHI415		SAR EVALUATION REPORT		Reviewed by: Quality Manager
Document S/N: 0Y1205290731.A3L	Test Dates: 05/31/12 - 06/19/12	DUT Type: Portable Handset		Page 48 of 61



14.3 Simultaneous Transmission Capabilities

According to Figure 14-1 and Figure 14-2, simultaneous transmission analysis of SAR may be required for this device for the licensed and unlicensed transmitters. Possible simultaneous transmissions for this device indicated in Table 14-1 were numerically summed using stand-alone SAR data and are shown in the following tables.

Per KDB Publication 648474, standalone Bluetooth SAR tests were not required. Standalone SAR tests for 2.4GHz and 5GHz WLAN were required. See Section 1.6(A) for more information.

**Table 14-1
Simultaneous Transmission Scenarios**

Ref.	Simultaneous Transmit Configurations	Power Reduction	SAR Report Section	Head	Body-Worn Accessory	Hot Spot	Note
				IEEE 1528, Supp C	Supplement C	FCC KDB 941225 D06 edges/sides	
A	1X CDMA 850 Voice + LTE 782 MHz Data	LTE	Section 14.6	Table 14-7	Table 14-8	-	SVLTE
B	1X CDMA 1900 Voice + LTE 782 MHz Data			Table 14-7	Table 14-8	-	SVLTE
C	1X CDMA 850 Voice + 2.4 GHz WIFI	-	Section 14.4	Table 14-2	Table 14-4	-	
D	1X CDMA 850 Voice + 5 GHz WIFI			Table 14-3	Table 14-5	-	
E	1X CDMA 1900 Voice + 2.4 GHz WIFI			Table 14-2	Table 14-4	-	
F	1X CDMA 1900 Voice + 5 GHz WIFI			Table 14-3	Table 14-5	-	
G	GSM850 Voice + 2.4 GHz WIFI			Table 14-2	Table 14-4	-	
H	GSM850 Voice + 5 GHz WIFI			Table 14-3	Table 14-5	-	
I	GSM1900 Voice + 2.4 GHz WIFI			Table 14-2	Table 14-4	-	
J	GSM1900 Voice + 5 GHz WIFI			Table 14-3	Table 14-5	-	
K	1X CDMA 850 Voice + LTE 782 MHz Data + 2.4 GHz WIFI	LTE	Section 14.6	Table 14-7	Table 14-8	Table 14-9	Voice + LTE + WIFI Hotspot
L	1X CDMA 1900 Voice + LTE 782 MHz Data + 2.4 GHz WIFI			Table 14-7	Table 14-8	Table 14-9	Voice + LTE + WIFI Hotspot
M	1X CDMA 850 Data + 2.4 GHz WIFI	-	Section 14.5	-	-	Table 14-6	1X CDMA Data +WIFI Hotspot
N	1X CDMA 1900 Data + 2.4 GHz WIFI			-	-	Table 14-6	1X CDMA Data +WIFI Hotspot
O	EVDO 850 Data + 2.4 GHz WIFI			-	-	Table 14-6	EVDO+WIFI Hotspot
P	EVDO 1900 Data + 2.4 GHz WIFI			-	-	Table 14-6	EVDO+WIFI Hotspot
Q	LTE 782 MHz Data + 2.4 GHz WIFI			-	-	Table 14-6	LTE+WIFI Hotspot
R	GPRS/EDGE 850 Data + 2.4 GHz WIFI			-	-	Table 14-6	GPRS/EDGE + WIFI Hotspot
S	GPRS/EDGE 1900 Data + 2.4 GHz WIFI			-	-	Table 14-6	GPRS/EDGE + WIFI Hotspot

FCC ID: A3LSCH1415		SAR EVALUATION REPORT		Reviewed by: Quality Manager
Document S/N: 0Y1205290731.A3L	Test Dates: 05/31/12 - 06/19/12	DUT Type: Portable Handset		Page 49 of 61



14.4 Voice + WIFI Simultaneous Transmission Analysis

Table 14-2
Simultaneous Transmission Scenario (Held to Ear)

Table 14-1 Simult. Tx Ref	Configuration	Cell. CDMA SAR (W/kg)	2.4 GHz WLAN SAR (W/kg)	Σ SAR (W/kg)	Table 14-1 Simult. Tx Ref	Configuration	PCS CDMA SAR (W/kg)	2.4 GHz WLAN SAR (W/kg)	Σ SAR (W/kg)
C	Target Power (dBm)	24.5	-	0.275	E	Target Power (dBm)	24.5	-	0.242
	Reference	Table 13-1	Table 13-7			Reference	Table 13-2	Table 13-7	
	Right Cheek	0.234	0.041			Right Cheek	0.201	0.041	
	Right Tilt	0.171	0.052			Right Tilt	0.054	0.052	
	Left Cheek	0.285	0.058			Left Cheek	0.101	0.058	
	Left Tilt	0.173	0.066			Left Tilt	0.037	0.066	
Table 14-1 Simult. Tx Ref	Configuration	GSM 850 SAR (W/kg)	2.4 GHz WLAN SAR (W/kg)	Σ SAR (W/kg)	Table 14-1 Simult. Tx Ref	Configuration	GSM 1900 SAR (W/kg)	2.4 GHz WLAN SAR (W/kg)	Σ SAR (W/kg)
	Target Power (dBm)	32	-			Target Power (dBm)	30	-	
	Reference	Table 13-3	Table 13-7			Reference	Table 13-4	Table 13-7	
	Right Cheek	0.224	0.041			Right Cheek	0.148	0.041	
	Right Tilt	0.125	0.052			Right Tilt	0.045	0.052	
	Left Cheek	0.261	0.058			Left Cheek	0.083	0.058	
Left Tilt	0.137	0.066	Left Tilt	0.045	0.066				
G	Target Power (dBm)	32	-	0.265	I	Target Power (dBm)	30	-	0.189
	Reference	Table 13-3	Table 13-7			Reference	Table 13-4	Table 13-7	
	Right Cheek	0.224	0.041			Right Cheek	0.148	0.041	
	Right Tilt	0.125	0.052			Right Tilt	0.045	0.052	
	Left Cheek	0.261	0.058			Left Cheek	0.083	0.058	
	Left Tilt	0.137	0.066			Left Tilt	0.045	0.066	

Table 14-3
Simultaneous Transmission Scenario (Held to Ear)

Table 14-1 Simult. Tx Ref	Configuration	Cell. CDMA SAR (W/kg)	5 GHz WLAN SAR (W/kg)	Σ SAR (W/kg)	Table 14-1 Simult. Tx Ref	Configuration	PCS CDMA SAR (W/kg)	5 GHz WLAN SAR (W/kg)	Σ SAR (W/kg)
D	Target Power (dBm)	24.5	-	0.267	F	Target Power (dBm)	24.5	-	0.234
	Reference	Table 13-1	Table 13-8			Reference	Table 13-2	Table 13-8	
	Right Cheek	0.234	0.033			Right Cheek	0.201	0.033	
	Right Tilt	0.171	0.008			Right Tilt	0.054	0.008	
	Left Cheek	0.285	0.082			Left Cheek	0.101	0.082	
	Left Tilt	0.173	0.002			Left Tilt	0.037	0.002	
Table 14-1 Simult. Tx Ref	Configuration	GSM 850 SAR (W/kg)	5 GHz WLAN SAR (W/kg)	Σ SAR (W/kg)	Table 14-1 Simult. Tx Ref	Configuration	GSM 1900 SAR (W/kg)	5 GHz WLAN SAR (W/kg)	Σ SAR (W/kg)
	Target Power (dBm)	32	-			Target Power (dBm)	30	-	
	Reference	Table 13-3	Table 13-8			Reference	Table 13-4	Table 13-8	
	Right Cheek	0.224	0.033			Right Cheek	0.148	0.033	
	Right Tilt	0.125	0.008			Right Tilt	0.045	0.008	
	Left Cheek	0.261	0.082			Left Cheek	0.083	0.082	
Left Tilt	0.137	0.002	Left Tilt	0.045	0.002				
H	Target Power (dBm)	32	-	0.257	J	Target Power (dBm)	30	-	0.181
	Reference	Table 13-3	Table 13-8			Reference	Table 13-4	Table 13-8	
	Right Cheek	0.224	0.033			Right Cheek	0.148	0.033	
	Right Tilt	0.125	0.008			Right Tilt	0.045	0.008	
	Left Cheek	0.261	0.082			Left Cheek	0.083	0.082	
	Left Tilt	0.137	0.002			Left Tilt	0.045	0.002	



FCC ID: A3LSCHI415	 PCTEST ENGINEERING LABORATORY, INC.	SAR EVALUATION REPORT		Reviewed by: Quality Manager
Document S/N: 0Y1205290731.A3L	Test Dates: 05/31/12 - 06/19/12	DUT Type: Portable Handset		Page 50 of 61

**Table 14-4
Simultaneous Transmission Scenario (Body-Worn at 1.0 cm)**

Table 14-1 Simultaneous Tx. Ref.	Mode	Target Power (dBm)	CDMA/GSM SAR (W/kg)	2.4 GHz WLAN SAR (W/kg)	Σ SAR (W/kg)
			Table 13-9	Table 13-12	
C	Cell. CDMA	24.5	0.589	0.116	0.705
E	PCS CDMA	24.5	0.501	0.116	0.617
			Table 13-10	Table 13-12	
G	GSM 850	32	0.576	0.116	0.692
I	GSM 1900	30	0.469	0.116	0.585

**Table 14-5
Simultaneous Transmission Scenario (Body-Worn at 1.0 cm)**

Table 14-1 Simultaneous Tx. Ref.	Mode	Target Power (dBm)	CDMA/GSM SAR (W/kg)	5 GHz WLAN SAR (W/kg)	Σ SAR (W/kg)
			Table 13-9	Table 13-12	
D	Cell. CDMA	24.5	0.589	0.005	0.594
F	PCS CDMA	24.5	0.501	0.005	0.506
			Table 13-10	Table 13-12	
H	GSM 850	32	0.576	0.005	0.581
J	GSM 1900	30	0.469	0.005	0.474



FCC ID: A3LSCH1415	 PCTEST ENGINEERING LABORATORY, INC.	SAR EVALUATION REPORT		Reviewed by: Quality Manager
Document S/N: 0Y1205290731.A3L	Test Dates: 05/31/12 - 06/19/12	DUT Type: Portable Handset		Page 51 of 61

14.5 Hotspot SAR Simultaneous Transmission Analysis

Table 14-6
Simultaneous Transmission Scenario (Hotspot at 1.0 cm)

Table 14-1 Simultaneous Tx. Ref	Configuration	Cell. EVDO SAR (W/kg)	2.4 GHz WLAN SAR (W/kg)	Σ SAR (W/kg)	Table 14-1 Simultaneous Tx. Ref	Configuration	PCS EVDO SAR (W/kg)	2.4 GHz WLAN SAR (W/kg)	Σ SAR (W/kg)		
M, O	Target Power (dBm)	24.5	-	0.809	N, P	Target Power (dBm)	24.5	-	0.689		
	Reference	Table 13-13	Table 13-17			Reference	Table 13-13	Table 13-17			
	Back	0.693	0.116			0.333	Back	0.573		0.116	0.306
	Front	0.297	0.036			0.000	Front	0.270		0.036	0.000
	Top	-	-			0.150	Top	-		-	0.402
	Bottom	0.150	-			0.000	Bottom	0.402		-	0.000
	Right	-	-			0.609	Right	-		-	0.309
Left	0.499	0.110		Left	0.199	0.110					
	Table 14-1 Simultaneous Tx. Ref	Configuration	LTE Band 13 SAR (W/kg)	2.4 GHz WLAN SAR (W/kg)	Σ SAR (W/kg)						
	Q	Target Power (dBm)	24.5	-	0.344						
		Reference	Table 13-15	Table 13-17							
		Back	0.228	0.116		0.096					
		Front	0.060	0.036		0.000					
		Top	-	-		0.102					
		Bottom	0.102	-		0.131					
		Right	0.131	-		0.110					
	Left	-	0.110	0.110							
Table 14-1 Simultaneous Tx. Ref	Configuration	GPRS 850 SAR (W/kg)	2.4 GHz WLAN SAR (W/kg)	Σ SAR (W/kg)	Table 14-1 Simultaneous Tx. Ref	Configuration	GPRS 1900 SAR (W/kg)	2.4 GHz WLAN SAR (W/kg)	Σ SAR (W/kg)		
R	Target Power (dBm)	29.5	-	0.878	S	Target Power (dBm)	29	-	0.899		
	Reference	Table 13-14	Table 13-17			Reference	Table 13-14	Table 13-17			
	Back	0.762	0.116			0.404	Back	0.783		0.116	0.419
	Front	0.368	0.036			0.000	Front	0.383		0.036	0.000
	Top	-	-			0.148	Top	-		-	0.522
	Bottom	0.148	-			0.000	Bottom	0.522		-	0.000
	Right	-	-			0.617	Right	-		-	0.334
Left	0.507	0.110		Left	0.224	0.110					

Note: Per FCC KDB Publication 941225 D06, the edges with antennas more than 2.5 cm are not required to be evaluated for SAR (“-”).

FCC ID: A3LSCHI415	 PCTEST ENGINEERING LABORATORY, INC.	SAR EVALUATION REPORT		Reviewed by: Quality Manager
Document S/N: 0Y1205290731.A3L	Test Dates: 05/31/12 - 06/19/12	DUT Type: Portable Handset		Page 52 of 61

14.6 SVLTE Simultaneous Transmission Scenario Analysis

Table 14-7
Simultaneous Transmission Scenario (Held to Ear)

Table 14-1 Simult. Tx Ref	CDMA Power Level (dBm)	Configuration	Cell. CDMA SAR (W/kg)	LTE Band 13 SAR (W/kg)	2.4 GHz WLAN SAR (W/kg)	Σ SAR (W/kg)	
			1	2	3	1+2	1+2+3
A, K	P ≥ 18	Target Power (dBm)	24.5	19	-	1+2	1+2+3
		Reference	Table 13-1	Table 13-6	Table 13-7		
		Right Cheek	0.234	0.017	0.041	0.251	0.292
		Right Tilt	0.171	0.029	0.052	0.200	0.252
		Left Cheek	0.285	0.025	0.058	0.310	0.368
		Left Tilt	0.173	0.024	0.066	0.197	0.263
	P < 18	Target Power (dBm)	18	23	-		
		Reference	Table 13-1	Table 13-5	Table 13-7		
		Right Cheek	0.058	0.084	0.041	0.142	0.183
		Right Tilt	0.044	0.052	0.052	0.096	0.148
		Left Cheek	0.081	0.054	0.058	0.135	0.193
		Left Tilt	0.050	0.036	0.066	0.086	0.152

Table 14-1 Simult. Tx Ref	CDMA Power Level (dBm)	Configuration	PCS CDMA SAR (W/kg)	LTE Band 13 SAR (W/kg)	2.4 GHz WLAN SAR (W/kg)	Σ SAR (W/kg)	
			1	2	3	1+2	1+2+3
B, L	P ≥ 18	Target Power (dBm)	24.5	19	-	1+2	1+2+3
		Reference	Table 13-2	Table 13-6	Table 13-7		
		Right Cheek	0.201	0.017	0.041	0.218	0.259
		Right Tilt	0.054	0.029	0.052	0.083	0.135
		Left Cheek	0.101	0.025	0.058	0.126	0.184
		Left Tilt	0.037	0.024	0.066	0.061	0.127
	P < 18	Target Power (dBm)	18	23	-		
		Reference	Table 13-2	Table 13-5	Table 13-7		
		Right Cheek	0.034	0.084	0.041	0.118	0.159
		Right Tilt	0.012	0.052	0.052	0.064	0.116
		Left Cheek	0.021	0.054	0.058	0.075	0.133
		Left Tilt	0.013	0.036	0.066	0.049	0.115



FCC ID: A3LSCHI415	 PCTEST ENGINEERING LABORATORY, INC.	SAR EVALUATION REPORT		Reviewed by: Quality Manager
Document S/N: 0Y1205290731.A3L	Test Dates: 05/31/12 - 06/19/12	DUT Type: Portable Handset		Page 53 of 61

Table 14-8
Simultaneous Transmission Scenario (Body-worn at 1.0 cm)

Table 14-1 Simultaneous Tx. Ref.	CDMA Power Level (dBm)	Mode	CDMA/GSM SAR (W/kg)	LTE Band 13 SAR (W/kg)	2.4 GHz WLAN SAR (W/kg)	Σ SAR (W/kg)	
		Tx Ant	1	2	3		
		Target Power	24.5	19	-	1+2	1+2+3
		Reference	Table 13-9	Table 13-11	Table 13-12		
A, K	P \geq 18	Cell. CDMA	0.589	0.088	0.116	0.677	0.793
B, L		PCS CDMA	0.501	0.088	0.116	0.589	0.705
		Target Power (dBm)	18	23	-		
		Reference	Table 13-9	Table 13-11	Table 13-12		
A, K	P < 18	Cell. CDMA	0.174	0.228	0.116	0.402	0.518
B, L		PCS CDMA	0.110	0.228	0.116	0.338	0.454

Table 14-9
Simultaneous Transmission Scenario (Hotspot at 1.0 cm)



Table 14-1 Simultaneous Tx. Ref	CDMA Power Level (dBm)	Configuration	Cell. CDMA SAR (W/kg)	LTE Band 13 SAR (W/kg)	2.4 GHz WLAN SAR (W/kg)	Σ SAR (W/kg)
		Tx Ant.	1	2	3	
K	P \geq 18	Target Power (dBm)	24.5	19	-	
		Reference	Table 13-13	Table 13-16	Table 13-17	1+2+3
		Back	0.589	0.088	0.116	0.793
		Front	0.307	0.036	0.036	0.379
		Top	-	-	-	0.000
		Bottom	0.153	0.039	-	0.192
		Right	-	0.067	-	0.067
		Left	0.526	-	0.110	0.636
	P < 18	Target Power (dBm)	18	23	-	
		Reference	Table 13-13	Table 13-15	Table 13-17	
		Back	0.174	0.228	0.116	0.518
		Front	0.077	0.060	0.036	0.173
		Top	-	-	-	0.000
		Bottom	0.031	0.102	-	0.133
		Right	-	0.131	-	0.131
		Left	0.120	-	0.110	0.230

Table 14-1 Simultaneous Tx. Ref	CDMA Power Level (dBm)	Configuration	PCS CDMA SAR (W/kg)	LTE Band 13 SAR (W/kg)	2.4 GHz WLAN SAR (W/kg)	Σ SAR (W/kg)
			1	2	3	
L	$P \geq 18$	Tx Ant.	1	2	3	
		Target Power (dBm)	24.5	19	-	
		Reference	Table 13-13	Table 13-16	Table 13-17	1+2+3
		Back	0.501	0.088	0.116	0.705
		Front	0.259	0.036	0.036	0.331
		Top	-	-	-	0.000
		Bottom	0.420	0.039	-	0.459
		Right	-	0.067	-	0.067
		Left	0.187	-	0.110	0.297
	$P < 18$	Target Power (dBm)	18	23	-	
		Reference	Table 13-13	Table 13-15	Table 13-17	
		Back	0.110	0.228	0.116	0.454
		Front	0.048	0.060	0.036	0.144
		Top	-	-	-	0.000
		Bottom	0.092	0.102	-	0.194
		Right	-	0.131	-	0.131
		Left	0.034	-	0.110	0.144

Note: Per FCC KDB Publication 941225 D06, the edges with antennas more than 2.5 cm are not required to be evaluated for SAR (“-”).

14.7 Simultaneous Transmission Conclusion



The above numerical summed SAR was below the SAR limit. Therefore, the above analysis is sufficient to determine that simultaneous transmission cases will not exceed the SAR limit. No volumetric SAR summation is required per FCC KDB Publication 648474.

FCC ID: A3LSCHI415	 PCTEST ENGINEERING LABORATORY, INC.	SAR EVALUATION REPORT		Reviewed by: Quality Manager
Document S/N: 0Y1205290731.A3L	Test Dates: 05/31/12 - 06/19/12	DUT Type: Portable Handset		Page 55 of 61

15 EQUIPMENT LIST

Manufacturer	Model	Description	Cal Date	Cal Interval	Cal Due	Serial Number
Agilent	8648D	(9kHz-4GHz) Signal Generator	10/10/2011	Annual	10/10/2012	3613A00315
Agilent	E5515C	Wireless Communications Test Set	2/12/2012	Annual	2/12/2013	GB45360985
Agilent	E5515C	Wireless Communications Test Set	2/14/2012	Annual	2/14/2013	GB43304447
Agilent	E5515C	Wireless Communications Test Set	2/14/2012	Annual	2/14/2013	GB43163447
Agilent	85070E	Dielectric Probe Kit	3/8/2012	Annual	3/8/2013	MY44300633
Agilent	8648D	Signal Generator	4/3/2012	Annual	4/3/2013	3629U00687
Agilent	8753E	(30kHz-6GHz) Network Analyzer	4/3/2012	Annual	4/3/2013	US37390350
Agilent	8753E	(30kHz-6GHz) Network Analyzer	4/4/2012	Annual	4/4/2013	JP38020182
Agilent	E5515C	Wireless Communications Tester	4/4/2012	Annual	4/4/2013	US41140256
Agilent	E8257D	(250kHz-20GHz) Signal Generator	4/5/2012	Annual	4/5/2013	MY45470194
Agilent	85047A	S-Parameter Test Set	N/A			2904A00579
Amplifier Research	5S1G4	5W, 800MHz-4.2GHz	CBT	N/A	CBT	21910
Anritsu	ML2438A	Power Meter	10/13/2011	Annual	10/13/2012	1070030
Anritsu	MA2411B	Pulse Sensor	10/13/2011	Annual	10/13/2012	1027293
Anritsu	ML2495A	Power Meter	10/13/2011	Annual	10/13/2012	1039008
Anritsu	MT8820C	Radio Communication Tester	11/11/2011	Annual	11/11/2012	6200901190
Anritsu	MA2481A	Power Sensor	2/14/2012	Annual	2/14/2013	5318
Anritsu	MA2481A	Power Sensor	2/14/2012	Annual	2/14/2013	5442
Anritsu	ML2438A	Power Meter	2/14/2012	Annual	2/14/2013	1190013
Anritsu	ML2438A	Power Meter	2/14/2012	Annual	2/14/2013	98150041
Anritsu	MA2481A	Power Sensor	2/14/2012	Annual	2/14/2013	5821
Anritsu	MA2481A	Power Sensor	2/14/2012	Annual	2/14/2013	8013
Anritsu	MA2481A	Power Sensor	2/14/2012	Annual	2/14/2013	2400
Anritsu	MA2481A	Power Sensor	4/5/2012	Annual	4/5/2013	5605
COMTECH	AR85729-5/5759B	Solid State Amplifier	CBT	N/A	CBT	M3W1A00-1002
COMTECH	AR85729-5	Solid State Amplifier	CBT	N/A	CBT	M1S5A00-009
Control Company	61220-416	Long-Stem Thermometer	2/15/2011	Biennial	2/15/2013	111331322
Control Company	61220-416	Long-Stem Thermometer	2/15/2011	Biennial	2/15/2013	111331323
Gigatronics	80701A	(0.05-18GHz) Power Sensor	10/12/2011	Annual	10/12/2012	1833460
Gigatronics	8651A	Universal Power Meter	10/12/2011	Annual	10/12/2012	8650319
Intelligent Weigh	PD-3000	Electronic Balance	3/27/2012	Annual	3/27/2013	11081534
MCL	BW-N6W5+	6dB Attenuator	CBT	N/A	CBT	1139
MiniCircuits	VLF-6000+	Low Pass Filter	CBT	N/A	CBT	N/A
MiniCircuits	VLF-6000+	Low Pass Filter	CBT	N/A	CBT	N/A
MiniCircuits	SLP-2400+	Low Pass Filter	CBT	N/A	CBT	R8979500903
Mini-Circuits	BW-N20W5+	DC to 18 GHz Precision Fixed 20 dB Attenuator	CBT	N/A	CBT	N/A
Mini-Circuits	NLP-2950+	Low Pass Filter DC to 2700 MHz	CBT	N/A	CBT	N/A
Mini-Circuits	NLP-1200+	Low Pass Filter DC to 1000 MHz	CBT	N/A	CBT	N/A
Narda	4014C-6	4 - 8 GHz SMA 6 dB Directional Coupler	CBT	N/A	CBT	N/A
Narda	4772-3	Attenuator (3dB)	CBT	N/A	CBT	9406
Narda	BW-S3W2	Attenuator (3dB)	CBT	N/A	CBT	120
Rohde & Schwarz	CMW500	LTE Radio Communication Tester	8/5/2011	Annual	8/5/2012	112347
Rohde & Schwarz	CMW500	LTE Radio Communication Tester	8/25/2011	Annual	8/25/2012	100976
Rohde & Schwarz	CMW500	LTE Radio Communication Tester	10/7/2011	Annual	10/7/2012	103962
Rohde & Schwarz	CMW500	LTE Radio Communication Tester	11/30/2011	Annual	11/30/2012	101699
Rohde & Schwarz	CMW500	LTE Radio Communication Tester	3/5/2012	Annual	3/5/2013	102060
Rohde & Schwarz	SMIQ03B	Signal Generator	4/5/2012	Annual	4/5/2013	DE27259
Rohde & Schwarz	NRVD	Dual Channel Power Meter	4/8/2011	Biennial	4/8/2013	101695
Seekonk	NC-100	Torque Wrench (8" lb)	11/29/2011	Triennial	11/29/2014	21053
Seekonk	NC-100	Torque Wrench (8" lb)	3/5/2012	Triennial	3/5/2015	N/A
Seekonk	NC-100	Torque Wrench (8" lb)	3/5/2012	Triennial	3/5/2015	N/A
SPEAG	D1900V2	1900 MHz SAR Dipole	7/22/2011	Annual	7/22/2012	5d080
SPEAG	EX3DV4	SAR Probe	7/27/2011	Annual	7/27/2012	3561
SPEAG	D2450V2	2450 MHz SAR Dipole	8/19/2011	Annual	8/19/2012	719
SPEAG	D750V3	750 MHz Dipole	10/27/2011	Annual	10/27/2012	1046
Speag	DAK-3.5	Dielectric Assessment Kit	12/1/2011	Annual	12/1/2012	1031
SPEAG	DAE4	Dasy Data Acquisition Electronics	1/18/2012	Annual	1/18/2013	1272
SPEAG	D5GHzV2	5 GHz SAR Dipole	1/19/2012	Annual	1/19/2013	1057
SPEAG	EX3DV4	SAR Probe	1/27/2012	Annual	1/27/2013	3589
SPEAG	ES3DV3	SAR Probe	2/7/2012	Annual	2/7/2013	3288
SPEAG	DAE4	Dasy Data Acquisition Electronics	2/15/2012	Annual	2/15/2013	1323
SPEAG	D835V2	835 MHz SAR Dipole	2/17/2012	Annual	2/17/2013	4d133
SPEAG	ES3DV3	SAR Probe	2/21/2012	Annual	2/21/2013	3258
SPEAG	D1900V2	1900 MHz SAR Dipole	2/22/2012	Annual	2/22/2013	5d149
SPEAG	ES3DV3	SAR Probe	3/16/2012	Annual	3/16/2013	3209
SPEAG	DAE4	Dasy Data Acquisition Electronics	4/12/2012	Annual	4/12/2013	1333
SPEAG	DAE4	Dasy Data Acquisition Electronics	4/19/2012	Annual	4/19/2013	665
SPEAG	D835V2	835 MHz SAR Dipole	4/20/2012	Annual	4/20/2013	4d119
SPEAG	ES3DV2	SAR Probe	8/25/2011	Annual	8/25/2012	3022
Tektronix	RSA-6114A	Real Time Spectrum Analyzer	4/5/2012	Annual	4/5/2013	B010177
VWR	36934-158	Wall-Mounted Thermometer	1/21/2011	Biennial	1/21/2013	111286445
VWR	36934-158	Wall-Mounted Thermometer	1/21/2011	Biennial	1/21/2013	111286460
VWR	36934-158	Wall-Mounted Thermometer	1/21/2011	Biennial	1/21/2013	111286454

Note: CBT (Calibrated Before Testing). Prior to testing, the measurement paths containing a cable, attenuator, amplifier, coupler or filter were connected to a calibrated source (i.e. a signal generator) to determine the losses of the measurement path. The power meter offset was then adjusted to compensate for the measurement system losses. This level offset is stored within the power meter before measurements are made. This calibration verification procedure applies to the system verification and output power measurements. The calibrated reading is then taken directly from the power meter after compensation of the losses for all final power measurements.



FCC ID: A3LSCH1415		SAR EVALUATION REPORT		Reviewed by: Quality Manager
Document S/N: 0Y1205290731.A3L	Test Dates: 05/31/12 - 06/19/12	DUT Type: Portable Handset	Page 56 of 61	

16 MEASUREMENT UNCERTAINTIES

Applicable for frequencies less than 3000 MHz.

a	b	c	d	e= f(d,k)	f	g	h = c x f/e	i = c x g/e	k	
Uncertainty Component	IEEE 1528 Sec.	Tol. (± %)	Prob. Dist.	Div.	c _i 1gm	c _i 10 gms	1gm u _i (± %)	10gms u _i (± %)	v _i	
Measurement System										
Probe Calibration	E.2.1	6.0	N	1	1.0	1.0	6.0	6.0	∞	
Axial Isotropy	E.2.2	0.25	N	1	0.7	0.7	0.2	0.2	∞	
Hemishperical Isotropy	E.2.2	1.3	N	1	1.0	1.0	1.3	1.3	∞	
Boundary Effect	E.2.3	0.4	N	1	1.0	1.0	0.4	0.4	∞	
Linearity	E.2.4	0.3	N	1	1.0	1.0	0.3	0.3	∞	
System Detection Limits	E.2.5	5.1	N	1	1.0	1.0	5.1	5.1	∞	
Readout Electronics	E.2.6	1.0	N	1	1.0	1.0	1.0	1.0	∞	
Response Time	E.2.7	0.8	R	1.73	1.0	1.0	0.5	0.5	∞	
Integration Time	E.2.8	2.6	R	1.73	1.0	1.0	1.5	1.5	∞	
RF Ambient Conditions	E.6.1	3.0	R	1.73	1.0	1.0	1.7	1.7	∞	
Probe Positioner Mechanical Tolerance	E.6.2	0.4	R	1.73	1.0	1.0	0.2	0.2	∞	
Probe Positioning w/ respect to Phantom	E.6.3	2.9	R	1.73	1.0	1.0	1.7	1.7	∞	
Extrapolation, Interpolation & Integration algorithms for Max. SAR Evaluation	E.5	1.0	R	1.73	1.0	1.0	0.6	0.6	∞	
Test Sample Related										
Test Sample Positioning	E.4.2	6.0	N	1	1.0	1.0	6.0	6.0	287	
Device Holder Uncertainty	E.4.1	3.32	R	1.73	1.0	1.0	1.9	1.9	∞	
Output Power Variation - SAR drift measurement	6.6.2	5.0	R	1.73	1.0	1.0	2.9	2.9	∞	
Phantom & Tissue Parameters										
Phantom Uncertainty (Shape & Thickness tolerances)	E.3.1	4.0	R	1.73	1.0	1.0	2.3	2.3	∞	
Liquid Conductivity - deviation from target values	E.3.2	5.0	R	1.73	0.64	0.43	1.8	1.2	∞	
Liquid Conductivity - measurement uncertainty	E.3.3	3.8	N	1	0.64	0.43	2.4	1.6	6	
Liquid Permittivity - deviation from target values	E.3.2	5.0	R	1.73	0.60	0.49	1.7	1.4	∞	
Liquid Permittivity - measurement uncertainty	E.3.3	4.5	N	1	0.60	0.49	2.7	2.2	6	
Combined Standard Uncertainty (k=1)							RSS	12.1	11.7	299
Expanded Uncertainty (95% CONFIDENCE LEVEL)							k=2	24.2	23.5	



The above measurement uncertainties are according to IEEE Std. 1528-2003

FCC ID: A3LSCH1415	 PCTEST ENGINEERING LABORATORY, INC.	SAR EVALUATION REPORT		Reviewed by: Quality Manager
Document S/N: 0Y1205290731.A3L	Test Dates: 05/31/12 - 06/19/12	DUT Type: Portable Handset		Page 57 of 61

Applicable for frequencies up to 6 GHz.

a	b	c	d	e= f(d,k)	f	g	h = c x f/e	i = c x g/e	k	
Uncertainty Component	IEEE 1528 Sec.	Tol. (± %)	Prob. Dist.	Div.	c _i 1gm	c _i 10 gms	1gm u _i (± %)	10gms u _i (± %)	v _i	
Measurement System										
Probe Calibration	E.2.1	6.55	N	1	1.0	1.0	6.6	6.6	∞	
Axial Isotropy	E.2.2	0.25	N	1	0.7	0.7	0.2	0.2	∞	
Hemishperical Isotropy	E.2.2	1.3	N	1	1.0	1.0	1.3	1.3	∞	
Boundary Effect	E.2.3	0.4	N	1	1.0	1.0	0.4	0.4	∞	
Linearity	E.2.4	0.3	N	1	1.0	1.0	0.3	0.3	∞	
System Detection Limits	E.2.5	5.1	N	1	1.0	1.0	5.1	5.1	∞	
Readout Electronics	E.2.6	1.0	N	1	1.0	1.0	1.0	1.0	∞	
Response Time	E.2.7	0.8	R	1.73	1.0	1.0	0.5	0.5	∞	
Integration Time	E.2.8	2.6	R	1.73	1.0	1.0	1.5	1.5	∞	
RF Ambient Conditions	E.6.1	3.0	R	1.73	1.0	1.0	1.7	1.7	∞	
Probe Positioner Mechanical Tolerance	E.6.2	0.4	R	1.73	1.0	1.0	0.2	0.2	∞	
Probe Positioning w/ respect to Phantom	E.6.3	2.9	R	1.73	1.0	1.0	1.7	1.7	∞	
Extrapolation, Interpolation & Integration algorithms for Max. SAR Evaluation	E.5	1.0	R	1.73	1.0	1.0	0.6	0.6	∞	
Test Sample Related										
Test Sample Positioning	E.4.2	6.0	N	1	1.0	1.0	6.0	6.0	287	
Device Holder Uncertainty	E.4.1	3.32	R	1.73	1.0	1.0	1.9	1.9	∞	
Output Power Variation - SAR drift measurement	6.6.2	5.0	R	1.73	1.0	1.0	2.9	2.9	∞	
Phantom & Tissue Parameters										
Phantom Uncertainty (Shape & Thickness tolerances)	E.3.1	4.0	R	1.73	1.0	1.0	2.3	2.3	∞	
Liquid Conductivity - deviation from target values	E.3.2	5.0	R	1.73	0.64	0.43	1.8	1.2	∞	
Liquid Conductivity - measurement uncertainty	E.3.3	3.8	N	1	0.64	0.43	2.4	1.6	6	
Liquid Permittivity - deviation from target values	E.3.2	5.0	R	1.73	0.60	0.49	1.7	1.4	∞	
Liquid Permittivity - measurement uncertainty	E.3.3	4.5	N	1	0.60	0.49	2.7	2.2	6	
Combined Standard Uncertainty (k=1)							RSS	12.4	12.0	299
Expanded Uncertainty (95% CONFIDENCE LEVEL)							k=2	24.7	24.0	

The above measurement uncertainties are according to IEEE Std. 1528-2003



FCC ID: A3LSCHI415	 PCTEST ENGINEERING LABORATORY, INC.	SAR EVALUATION REPORT		Reviewed by: Quality Manager
Document S/N: 0Y1205290731.A3L	Test Dates: 05/31/12 - 06/19/12	DUT Type: Portable Handset		Page 58 of 61

17 CONCLUSION

17.1 Measurement Conclusion



The SAR evaluation indicates that the EUT complies with the RF radiation exposure limits of the FCC and Industry Canada, with respect to all parameters subject to this test. These measurements were taken to simulate the RF effects of RF exposure under worst-case conditions. Precise laboratory measures were taken to assure repeatability of the tests. The results and statements relate only to the item(s) tested.

Please note that the absorption and distribution of electromagnetic energy in the body are very complex phenomena that depend on the mass, shape, and size of the body, the orientation of the body with respect to the field vectors, and the electrical properties of both the body and the environment. Other variables that may play a substantial role in possible biological effects are those that characterize the environment (e.g. ambient temperature, air velocity, relative humidity, and body insulation) and those that characterize the individual (e.g. age, gender, activity level, debilitation, or disease). Because various factors may interact with one another to vary the specific biological outcome of an exposure to electromagnetic fields, any protection guide should consider maximal amplification of biological effects as a result of field-body interactions, environmental conditions, and physiological variables. [3]



FCC ID: A3LSCHI415	 PCTEST ENGINEERING LABORATORY, INC.	SAR EVALUATION REPORT		Reviewed by: Quality Manager
Document S/N: 0Y1205290731.A3L	Test Dates: 05/31/12 - 06/19/12	DUT Type: Portable Handset		Page 59 of 61

18 REFERENCES

- [1] Federal Communications Commission, ET Docket 93-62, Guidelines for Evaluating the Environmental Effects of Radiofrequency Radiation, Aug. 1996.
- [2] ANSI/IEEE C95.1-2005, American National Standard safety levels with respect to human exposure to radio frequency electromagnetic fields, 3kHz to 300GHz, New York: IEEE, 2006.
- [3] ANSI/IEEE C95.1-1992, American National Standard safety levels with respect to human exposure to radio frequency electromagnetic fields, 3kHz to 300GHz, New York: IEEE, Sept. 1992.
- [4] ANSI/IEEE C95.3-2002, IEEE Recommended Practice for the Measurement of Potentially Hazardous Electromagnetic Fields - RF and Microwave, New York: IEEE, December 2002.
- [5] Federal Communications Commission, OET Bulletin 65 (Edition 97-01), Supplement C (Edition 01-01), Evaluating Compliance with FCC Guidelines for Human Exposure to Radiofrequency Electromagnetic Fields, June 2001.
- [6] IEEE Standards Coordinating Committee 34 – IEEE Std. 1528-2003, Recommended Practice for Determining the Peak Spatial-Average Specific Absorption Rate (SAR) in the Human Body Due to Wireless Communications Devices.
- [7] NCRP, National Council on Radiation Protection and Measurements, Biological Effects and Exposure Criteria for RadioFrequency Electromagnetic Fields, NCRP Report No. 86, 1986. Reprinted Feb. 1995.
- [8] T. Schmid, O. Egger, N. Kuster, Automated E-field scanning system for dosimetric assessments, IEEE Transaction on Microwave Theory and Techniques, vol. 44, Jan. 1996, pp. 105-113.
- [9] K. Pokovic, T. Schmid, N. Kuster, Robust setup for precise calibration of E-field probes in tissue simulating liquids at mobile communications frequencies, ICECOM97, Oct. 1997, pp. 120-124.
- [10] K. Pokovic, T. Schmid, and N. Kuster, E-field Probe with improved isotropy in brain simulating liquids, Proceedings of the ELMAR, Zadar, Croatia, June 23-25, 1996, pp. 172-175.
- [11] Schmid & Partner Engineering AG, Application Note: Data Storage and Evaluation, June 1998, p2.
- [12] V. Hombach, K. Meier, M. Burkhardt, E. Kuhn, N. Kuster, The Dependence of EM Energy Absorption upon Human Head Modeling at 900 MHz, IEEE Transaction on Microwave Theory and Techniques, vol. 44 no. 10, Oct. 1996, pp. 1865-1873.
- [13] N. Kuster and Q. Balzano, Energy absorption mechanism by biological bodies in the near field of dipole antennas above 300MHz, IEEE Transaction on Vehicular Technology, vol. 41, no. 1, Feb. 1992, pp. 17-23.
- [14] G. Hartsgrove, A. Kraszewski, A. Surowiec, Simulated Biological Materials for Electromagnetic Radiation Absorption Studies, University of Ottawa, Bioelectromagnetics, Canada: 1987, pp. 29-36.
- [15] Q. Balzano, O. Garay, T. Manning Jr., Electromagnetic Energy Exposure of Simulated Users of Portable Cellular Telephones, IEEE Transactions on Vehicular Technology, vol. 44, no.3, Aug. 1995.
- [16] W. Gander, Computermathematick, Birkhaeuser, Basel, 1992.
- [17] W.H. Press, S.A. Teukolsky, W.T. Vetterling, and B.P. Flannery, Numerical Recipes in C, The Art of Scientific Computing, Second edition, Cambridge University Press, 1992.

FCC ID: A3LSCHI415	 PCTEST ENGINEERING LABORATORY, INC.	SAR EVALUATION REPORT		Reviewed by: Quality Manager
Document S/N: 0Y1205290731.A3L	Test Dates: 05/31/12 - 06/19/12	DUT Type: Portable Handset		Page 60 of 61

- [18] Federal Communications Commission, OET Bulletin 65, Evaluating Compliance with FCC Guidelines for Human Exposure to Radiofrequency Electromagnetic Fields. Supplement C, Dec. 1997.
- [19] N. Kuster, R. Kastle, T. Schmid, Dosimetric evaluation of mobile communications equipment with known precision, IEEE Transaction on Communications, vol. E80-B, no. 5, May 1997, pp. 645-652.
- [20] CENELEC CLC/SC111B, European Prestandard (prENV 50166-2), Human Exposure to Electromagnetic Fields High-frequency: 10kHz-300GHz, Jan. 1995.
- [21] Prof. Dr. Niels Kuster, ETH, Eidgenössische Technische Hochschule Zürich, Dosimetric Evaluation of the Cellular Phone.
- [22] IEC 62209-1, Human exposure to radio frequency fields from hand-held and body-mounted wireless communication devices - Human models, instrumentation, and procedures - Part 1: Procedure to determine the specific absorption rate (SAR) for hand-held devices used in close proximity to the ear (frequency range of 300 MHz to 3 GHz), Feb. 2005.
- [23] Industry Canada RSS-102 Radio Frequency Exposure Compliance of Radiocommunication Apparatus (All Frequency Bands) Issue 4, March 2010.
- [24] Health Canada Safety Code 6 Limits of Human Exposure to Radio Frequency Electromagnetic Fields in the Frequency Range from 3 kHz – 300 GHz, 2009
- [25] FCC Public Notice DA-02-1438. Office of Engineering and Technology Announces a Transition Period for the Phantom Requirements of Supplement C to OET Bulletin 65, June 19, 2002
- [26] FCC SAR Measurement Procedures for 3G Devices KDB Publication 941225
- [27] SAR Measurement procedures for IEEE 802.11a/b/g KDB Publication 248227
- [28] FCC SAR Considerations for Handsets with Multiple Transmitters and Antennas, KDB Publication 648474
- [29] FCC Application Note for SAR Probe Calibration and System Verification Consideration for Measurements at 150 MHz – 3 GHz, KDB Publication 450824
- [30] FCC SAR Evaluation Considerations for Laptop Computers with Antennas Built-in on Display Screens, KDB Publication 616217
- [31] FCC SAR Measurement Requirements for 3 – 6 GHz, KDB Publication 865664
- [32] FCC Mobile Portable RF Exposure Procedure, KDB Publication 447498
- [33] FCC SAR Procedures for Dongle Transmitters, KDB Publication 447498
- [34] Anexo à Resolução No. 533, de 10 de Setembro de 2009.
- [35] FCC SAR Test Considerations for LTE Handsets and Data Modems, KDB Publication 941225.
- [36] IEC 62209-2, Human exposure to radio frequency fields from hand-held and body-mounted wireless communication devices - Human models, instrumentation, and procedures - Part 2: Procedure to determine the specific absorption rate (SAR) for wireless communication devices used in close proximity to the human body (frequency range of 30 MHz to 6 GHz), Mar. 2010.
- [37] FCC Hot Spot SAR v01, KDB Publication 941225 D06.

FCC ID: A3LSCHI415		SAR EVALUATION REPORT		Reviewed by: Quality Manager
Document S/N: 0Y1205290731.A3L	Test Dates: 05/31/12 - 06/19/12	DUT Type: Portable Handset	Page 61 of 61	

APPENDIX A: SAR TEST DATA

PCTEST ENGINEERING LABORATORY, INC.

DUT: A3LSCHI415; Type: Portable Handset; Serial: 0841-1298

Communication System: LTE RF Band 13; Frequency: 782 MHz; Duty Cycle: 1:1
Medium: 770 Head; Medium parameters used (interpolated):
 $f = 782 \text{ MHz}$; $\sigma = 0.931 \text{ mho/m}$; $\epsilon_r = 40.014$; $\rho = 1000 \text{ kg/m}^3$
Phantom section: Right Section

Test Date: 06-12-2012; Ambient Temp: 21.9°C; Tissue Temp: 21.6°C

Probe: EX3DV4 - SN3561; ConvF(8.38, 8.38, 8.38); Calibrated: 7/27/2011
Sensor-Surface: 4mm (Mechanical Surface Detection)
Electronics: DAE4 Sn1333; Calibrated: 4/12/2012
Phantom: SAM V5.0 Right; Type: QD000P40CD; Serial: 1647
Measurement SW: DASY52, Version 52.8 (0); SEMCAD X Version 14.6.4 (4989)

**Mode: LTE Band 13, Right Head, Touch, Mid.ch,
QPSK, 10 MHz Bandwidth, 1 RB, RB Offset 0**

Area Scan (7x12x1): Measurement grid: dx=15mm, dy=15mm
Zoom Scan (5x5x7)/Cube 0: Measurement grid: dx=8mm, dy=8mm, dz=5mm
Reference Value = 9.716 V/m; Power Drift = 0.10 dB
Peak SAR (extrapolated) = 0.1060 W/kg
SAR(1 g) = 0.084 mW/g; SAR(10 g) = 0.064 mW/g

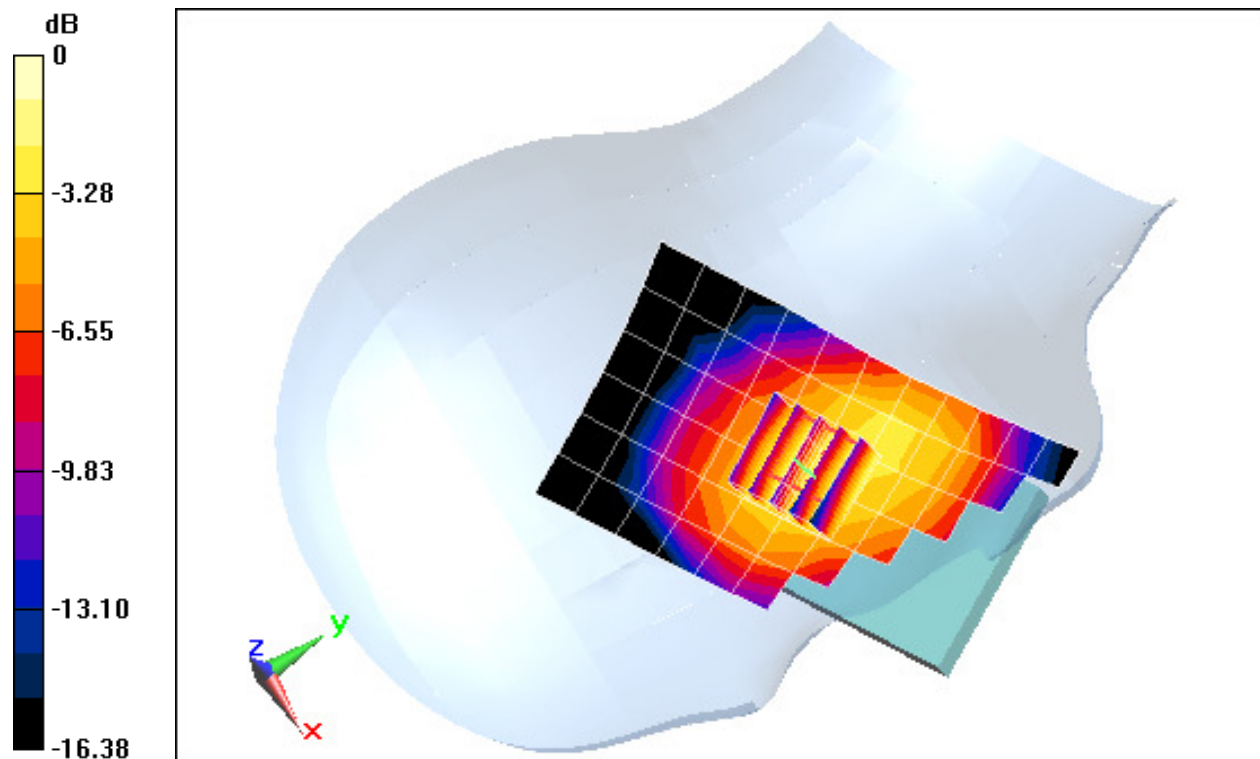

0 dB = 0.090mW/g = -20.92 dB mW/g

PCTEST ENGINEERING LABORATORY, INC.

DUT: A3LSCHI415; Type: Portable Handset; Serial: 0841-1298

Communication System: LTE RF Band 13; Frequency: 782 MHz; Duty Cycle: 1:1
Medium: 770 Head; Medium parameters used (interpolated):
 $f = 782 \text{ MHz}$; $\sigma = 0.931 \text{ mho/m}$; $\epsilon_r = 40.014$; $\rho = 1000 \text{ kg/m}^3$
Phantom section: Right Section

Test Date: 06-12-2012; Ambient Temp: 21.9°C; Tissue Temp: 21.6°C

Probe: EX3DV4 - SN3561; ConvF(8.38, 8.38, 8.38); Calibrated: 7/27/2011
Sensor-Surface: 4mm (Mechanical Surface Detection)
Electronics: DAE4 Sn1333; Calibrated: 4/12/2012
Phantom: SAM V5.0 Right; Type: QD000P40CD; Serial: 1647
Measurement SW: DASY52, Version 52.8 (0);SEMCAD X Version 14.6.4 (4989)

**Mode: LTE Band 13, Right Head, Tilt, Mid. ch,
QPSK, 10 MHz Bandwidth, 1 RB, RB Offset 0**

Area Scan (7x12x1): Measurement grid: dx=15mm, dy=15mm
Zoom Scan (5x5x7)/Cube 0: Measurement grid: dx=8mm, dy=8mm, dz=5mm
Reference Value = 7.562 V/m; Power Drift = -0.03 dB
Peak SAR (extrapolated) = 0.0680 W/kg
SAR(1 g) = 0.052 mW/g; SAR(10 g) = 0.039 mW/g

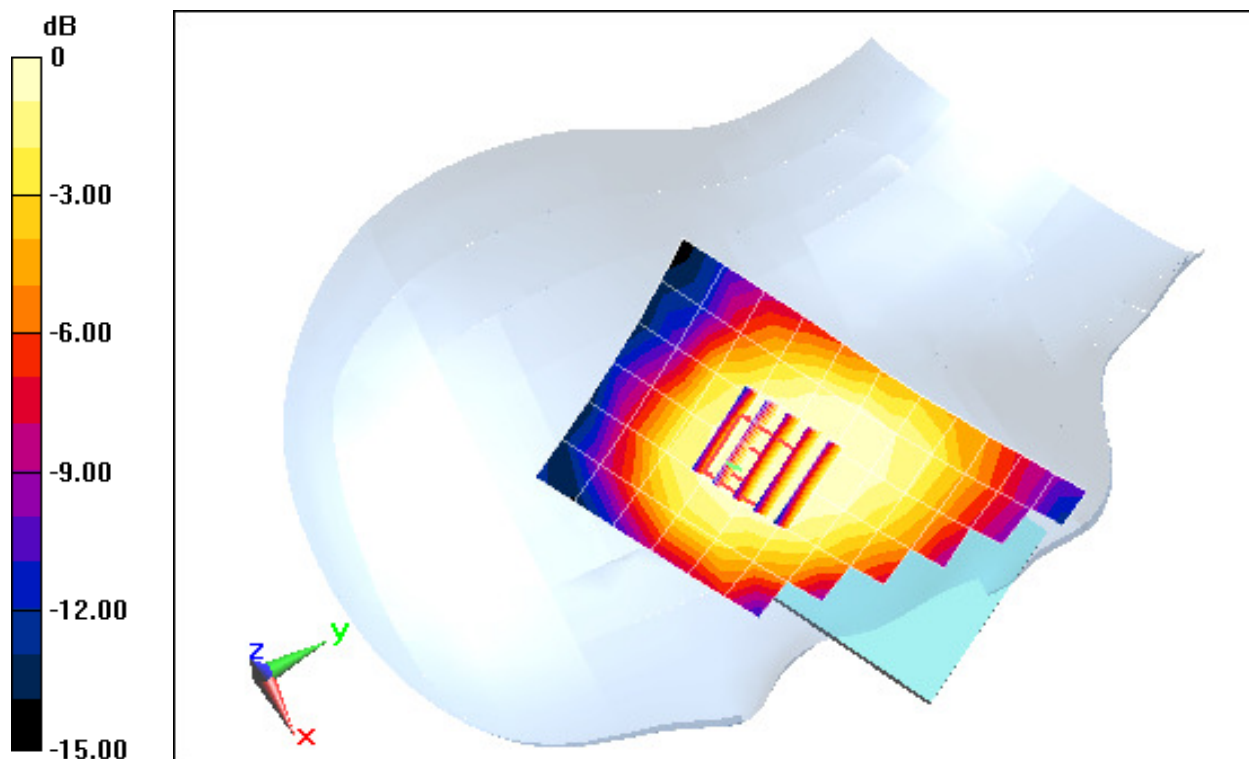

0 dB = 0.020mW/g = -33.98 dB mW/g

PCTEST ENGINEERING LABORATORY, INC.

DUT: A3LSCHI415; Type: Portable Handset; Serial: 0841-1298

Communication System: LTE RF Band 13; Frequency: 782 MHz; Duty Cycle: 1:1
Medium: 770 Head; Medium parameters used (interpolated):
 $f = 782 \text{ MHz}$; $\sigma = 0.931 \text{ mho/m}$; $\epsilon_r = 40.014$; $\rho = 1000 \text{ kg/m}^3$
Phantom section: Left Section

Test Date: 06-12-2012; Ambient Temp: 21.9°C; Tissue Temp: 21.6°C

Probe: EX3DV4 - SN3561; ConvF(8.38, 8.38, 8.38); Calibrated: 7/27/2011
Sensor-Surface: 4mm (Mechanical Surface Detection)
Electronics: DAE4 Sn1333; Calibrated: 4/12/2012
Phantom: SAM V5.0 Right; Type: QD000P40CD; Serial: 1647
Measurement SW: DASY52, Version 52.8 (0); SEMCAD X Version 14.6.4 (4989)

**Mode: LTE Band 13, Left Head, Touch, Mid.ch,
QPSK, 10 MHz Bandwidth, 1 RB, RB Offset 0**

Area Scan (7x14x1): Measurement grid: dx=15mm, dy=15mm
Zoom Scan (5x5x7)/Cube 0: Measurement grid: dx=8mm, dy=8mm, dz=5mm
Reference Value = 7.561 V/m; Power Drift = 0.19 dB
Peak SAR (extrapolated) = 0.0660 W/kg
SAR(1 g) = 0.054 mW/g; SAR(10 g) = 0.040 mW/g

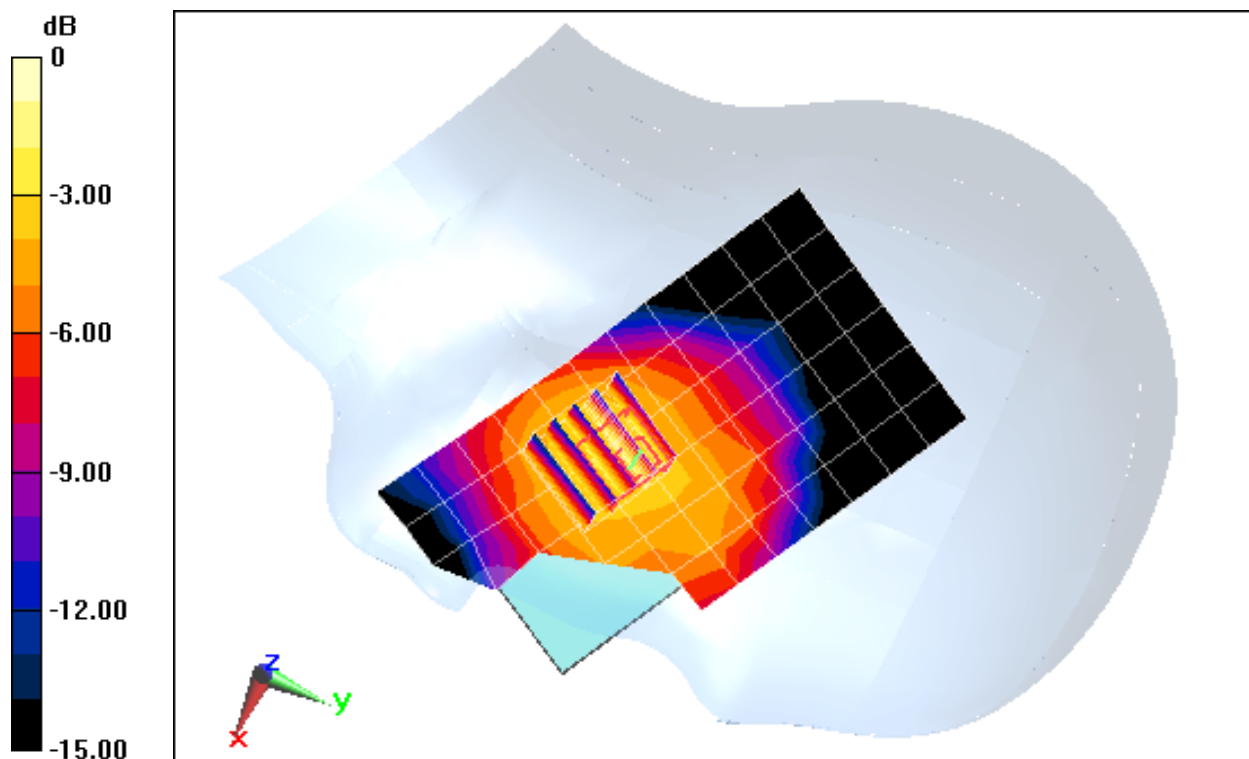

0 dB = 0.060mW/g = -24.44 dB mW/g

PCTEST ENGINEERING LABORATORY, INC.

DUT: A3LSCHI415; Type: Portable Handset; Serial: 0841-1298

Communication System: LTE RF Band 13; Frequency: 782 MHz; Duty Cycle: 1:1
Medium: 770 Head; Medium parameters used (interpolated):
 $f = 782 \text{ MHz}$; $\sigma = 0.931 \text{ mho/m}$; $\epsilon_r = 40.014$; $\rho = 1000 \text{ kg/m}^3$
Phantom section: Left Section

Test Date: 06-12-2012; Ambient Temp: 21.9°C; Tissue Temp: 21.6°C

Probe: EX3DV4 - SN3561; ConvF(8.38, 8.38, 8.38); Calibrated: 7/27/2011
Sensor-Surface: 4mm (Mechanical Surface Detection)
Electronics: DAE4 Sn1333; Calibrated: 4/12/2012
Phantom: SAM V5.0 Right; Type: QD000P40CD; Serial: 1647
Measurement SW: DASY52, Version 52.8 (0);SEMCAD X Version 14.6.4 (4989)

**Mode: LTE Band 13, Left Head, Tilt, Mid. ch,
QPSK, 10 MHz Bandwidth, 1 RB, RB Offset 0**

Area Scan (7x14x1): Measurement grid: dx=15mm, dy=15mm
Zoom Scan (5x5x7)/Cube 0: Measurement grid: dx=8mm, dy=8mm, dz=5mm
Reference Value = 5.173 V/m; Power Drift = -0.13 dB
Peak SAR (extrapolated) = 0.0470 W/kg
SAR(1 g) = 0.036 mW/g; SAR(10 g) = 0.026 mW/g

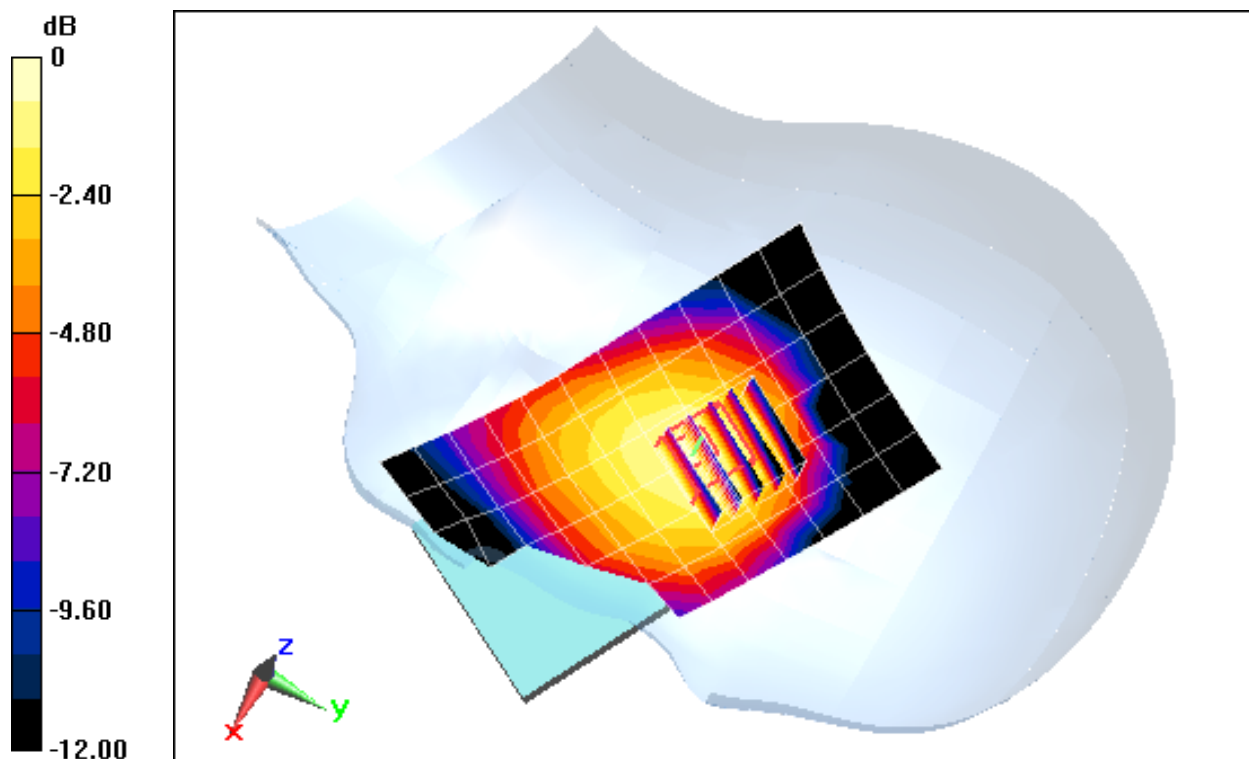

0 dB = 0.050mW/g = -26.02 dB mW/g

PCTEST ENGINEERING LABORATORY, INC.

DUT: A3LSCHI415; Type: Portable Handset; Serial: 0841-1297

Communication System: Cellular CDMA; Frequency: 836.52 MHz; Duty Cycle: 1:1

Medium: 835 Head; Medium parameters used (interpolated):

$f = 836.52$ MHz; $\sigma = 0.898$ mho/m; $\epsilon_r = 41.999$; $\rho = 1000$ kg/m³

Phantom section: Right Section

Test Date: 05-31-2012; Ambient Temp: 24.8°C; Tissue Temp: 23.2°C

Probe: ES3DV3 - SN3258; ConvF(6.01, 6.01, 6.01); Calibrated: 2/21/2012

Sensor-Surface: 4mm (Mechanical Surface Detection)

Electronics: DAE4 Sn1272; Calibrated: 1/18/2012

Phantom: SAM Sub; Type: SAM 4.0; Serial: TP-1403

Measurement SW: DASY4, Version 4.7 (80);SEMCAD X Version 14.6.4 (4989)

Mode: Cellular CDMA, Right Head, Touch, Mid.ch

Area Scan (7x14x1): Measurement grid: dx=15mm, dy=15mm

Zoom Scan (5x5x7)/Cube 0: Measurement grid: dx=8mm, dy=8mm, dz=5mm

Reference Value = 17.336 V/m; Power Drift = 0.0042 dB

Peak SAR (extrapolated) = 0.2840 W/kg

SAR(1 g) = 0.234 mW/g; SAR(10 g) = 0.180 mW/g

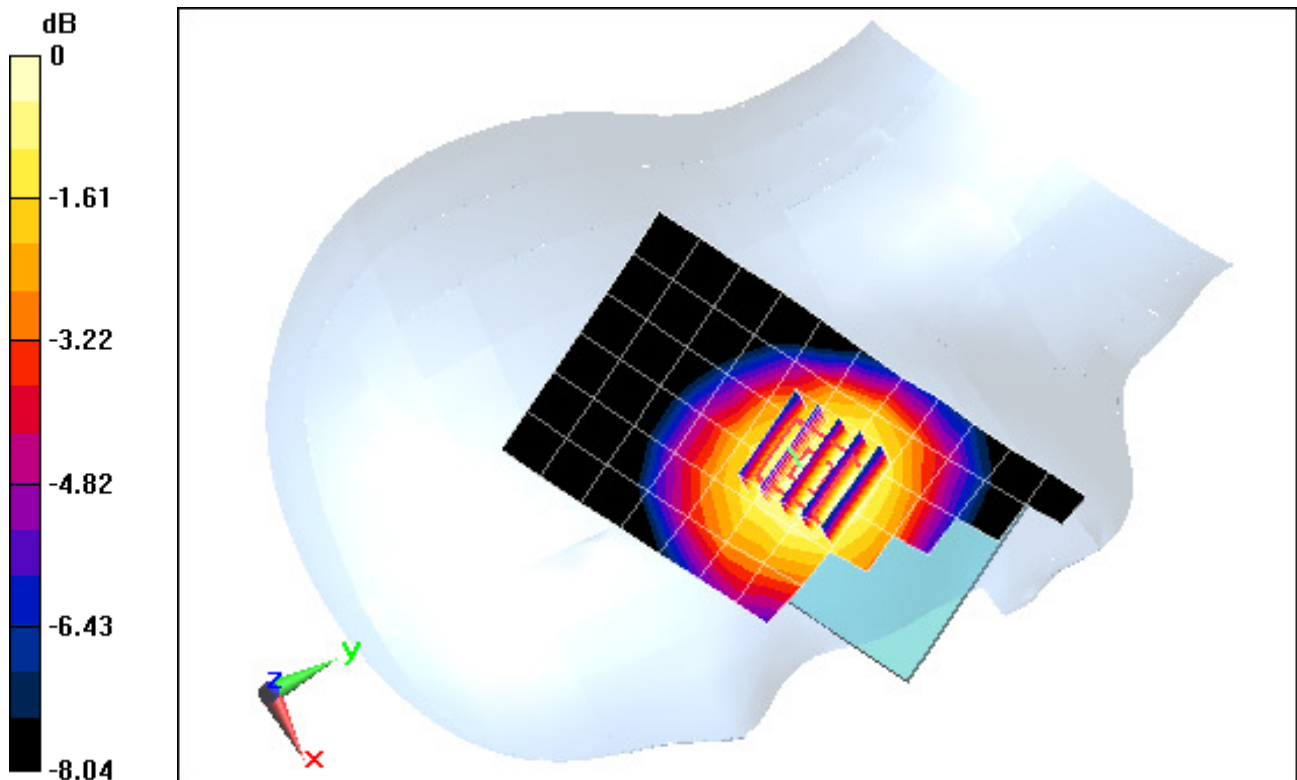

0 dB = 0.240mW/g = -12.40 dB mW/g

PCTEST ENGINEERING LABORATORY, INC.

DUT: A3LSCHI415; Type: Portable Handset; Serial: 0841-1297

Communication System: Cellular CDMA; Frequency: 836.52 MHz; Duty Cycle: 1:1

Medium: 835 Head; Medium parameters used (interpolated):

$f = 836.52$ MHz; $\sigma = 0.898$ mho/m; $\epsilon_r = 41.999$; $\rho = 1000$ kg/m³

Phantom section: Right Section

Test Date: 05-31-2012; Ambient Temp: 24.8°C; Tissue Temp: 23.2°C

Probe: ES3DV3 - SN3258; ConvF(6.01, 6.01, 6.01); Calibrated: 2/21/2012

Sensor-Surface: 4mm (Mechanical Surface Detection)

Electronics: DAE4 Sn1272; Calibrated: 1/18/2012

Phantom: SAM Sub; Type: SAM 4.0; Serial: TP-1403

Measurement SW: DASY4, Version 4.7 (80);SEMCAD X Version 14.6.4 (4989)

Mode: Cellular CDMA, Right Head, Tilt, Mid.ch

Area Scan (7x14x1): Measurement grid: dx=15mm, dy=15mm

Zoom Scan (5x5x7)/Cube 0: Measurement grid: dx=8mm, dy=8mm, dz=5mm

Reference Value = 14.977 V/m; Power Drift = -0.05 dB

Peak SAR (extrapolated) = 0.2070 W/kg

SAR(1 g) = 0.171 mW/g; SAR(10 g) = 0.133 mW/g

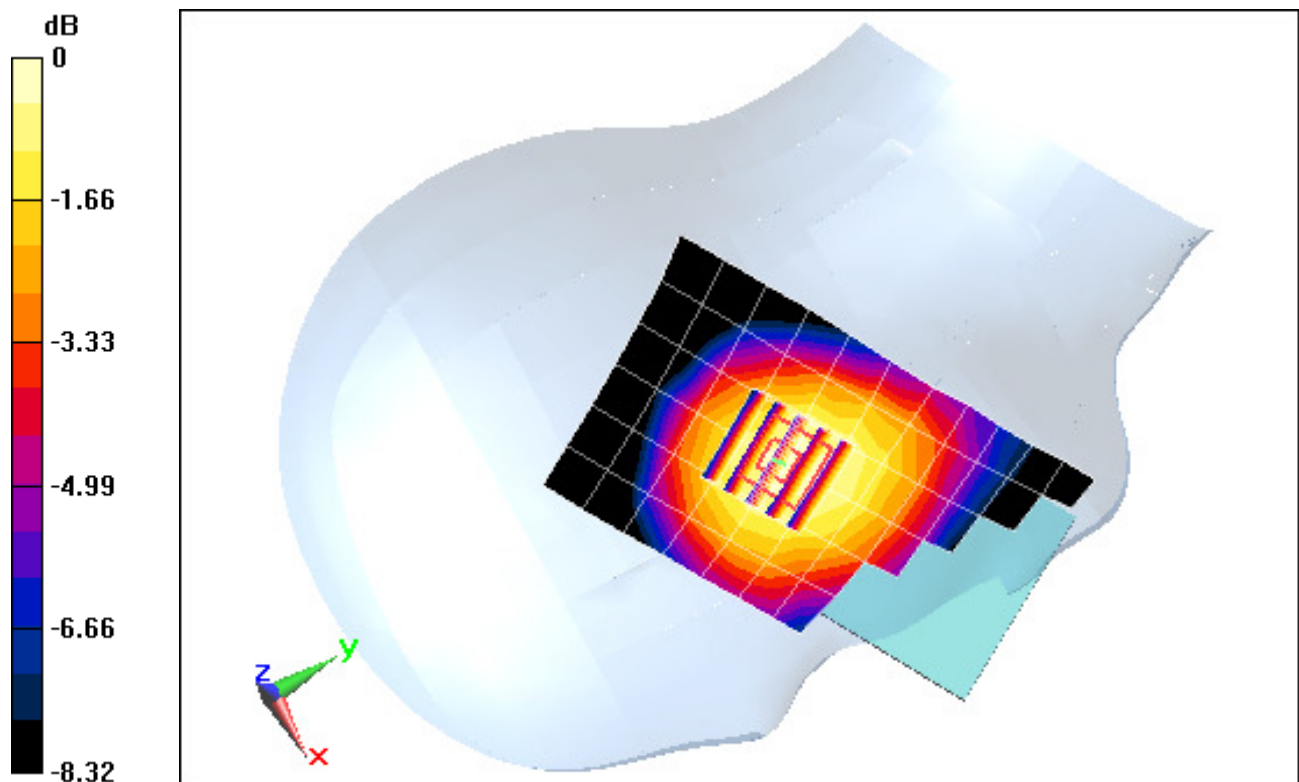

0 dB = 0.180mW/g = -14.89 dB mW/g

PCTEST ENGINEERING LABORATORY, INC.

DUT: A3LSCHI415; Type: Portable Handset; Serial: 0841-1297

Communication System: Cellular CDMA; Frequency: 836.52 MHz; Duty Cycle: 1:1

Medium: 835 Head; Medium parameters used (interpolated):

$f = 836.52$ MHz; $\sigma = 0.898$ mho/m; $\epsilon_r = 41.999$; $\rho = 1000$ kg/m³

Phantom section: Left Section

Test Date: 05-31-2012; Ambient Temp: 24.8°C; Tissue Temp: 23.2°C

Probe: ES3DV3 - SN3258; ConvF(6.01, 6.01, 6.01); Calibrated: 2/21/2012

Sensor-Surface: 4mm (Mechanical Surface Detection)

Electronics: DAE4 Sn1272; Calibrated: 1/18/2012

Phantom: SAM Sub; Type: SAM 4.0; Serial: TP-1403

Measurement SW: DASY4, Version 4.7 (80);SEMCAD X Version 14.6.4 (4989)

Mode: Cellular CDMA, Left Head, Touch, Mid.ch

Area Scan (7x14x1): Measurement grid: dx=15mm, dy=15mm

Zoom Scan (5x5x7)/Cube 0: Measurement grid: dx=8mm, dy=8mm, dz=5mm

Reference Value = 19.317 V/m; Power Drift = -0.01 dB

Peak SAR (extrapolated) = 0.3620 W/kg

SAR(1 g) = 0.285 mW/g; SAR(10 g) = 0.216 mW/g

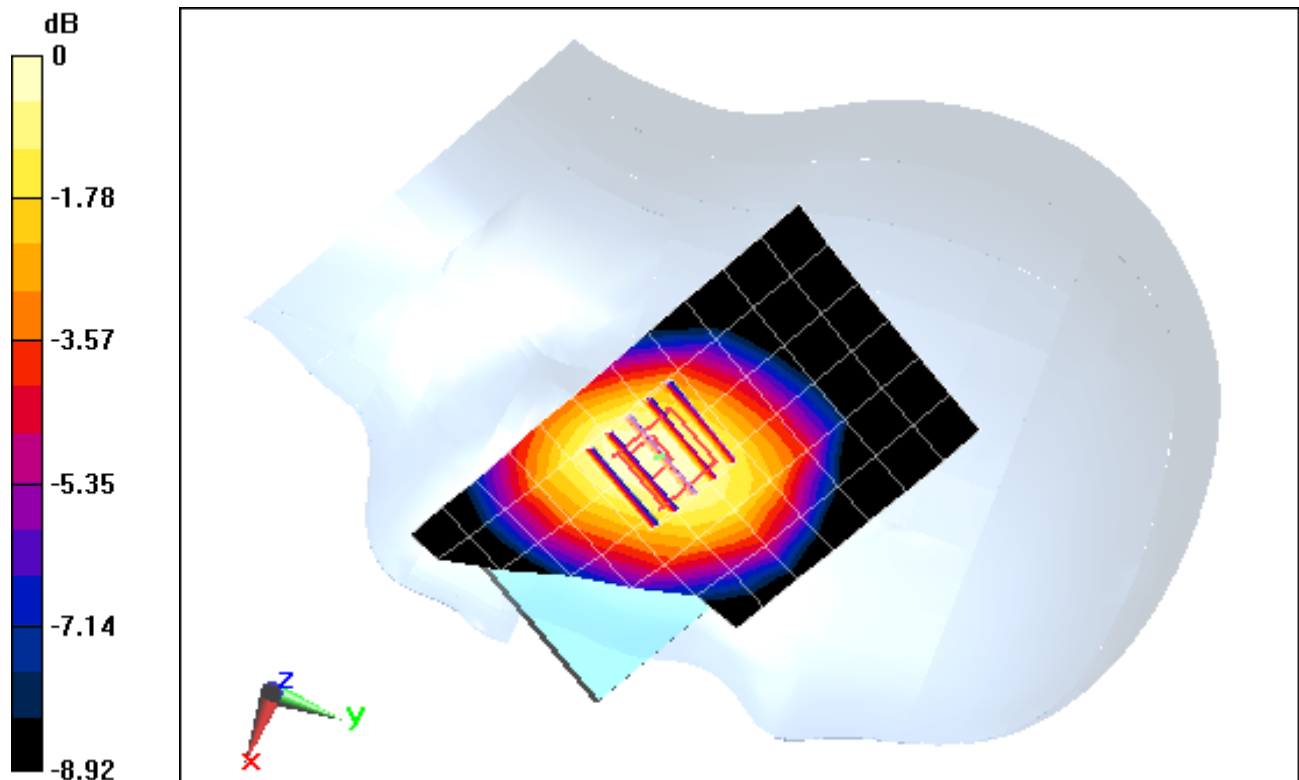

0 dB = 0.300mW/g = -10.46 dB mW/g

PCTEST ENGINEERING LABORATORY, INC.

DUT: A3LSCHI415; Type: Portable Handset; Serial: 0841-1297

Communication System: Cellular CDMA; Frequency: 836.52 MHz; Duty Cycle: 1:1

Medium: 835 Head; Medium parameters used (interpolated):

$f = 836.52$ MHz; $\sigma = 0.898$ mho/m; $\epsilon_r = 41.999$; $\rho = 1000$ kg/m³

Phantom section: Left Section

Test Date: 05-31-2012; Ambient Temp: 24.8°C; Tissue Temp: 23.2°C

Probe: ES3DV3 - SN3258; ConvF(6.01, 6.01, 6.01); Calibrated: 2/21/2012

Sensor-Surface: 4mm (Mechanical Surface Detection)

Electronics: DAE4 Sn1272; Calibrated: 1/18/2012

Phantom: SAM Sub; Type: SAM 4.0; Serial: TP-1403

Measurement SW: DASY4, Version 4.7 (80);SEMCAD X Version 14.6.4 (4989)

Mode: Cellular CDMA, Left Head, Tilt, Mid.ch

Area Scan (7x14x1): Measurement grid: dx=15mm, dy=15mm

Zoom Scan (5x5x7)/Cube 0: Measurement grid: dx=8mm, dy=8mm, dz=5mm

Reference Value = 15.057 V/m; Power Drift = -0.04 dB

Peak SAR (extrapolated) = 0.2110 W/kg

SAR(1 g) = 0.173 mW/g; SAR(10 g) = 0.136 mW/g

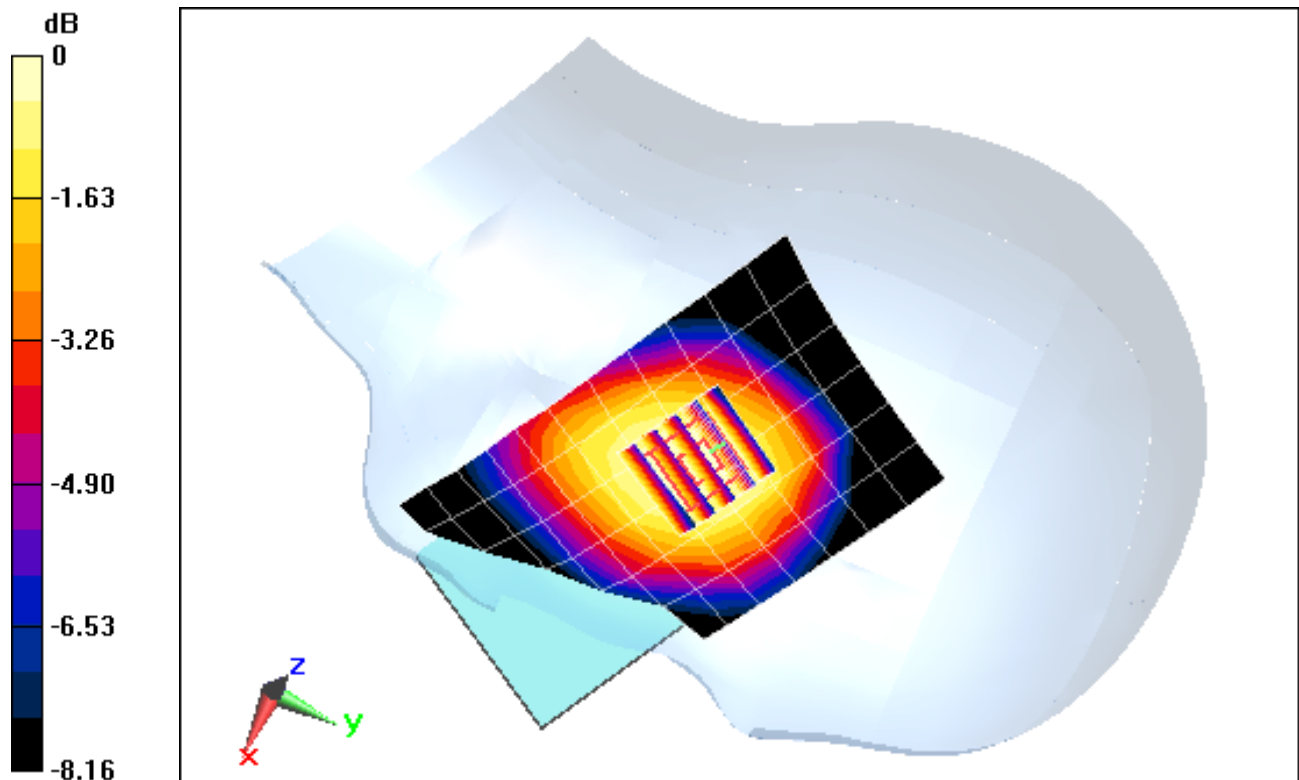

0 dB = 0.180mW/g = -14.89 dB mW/g

PCTEST ENGINEERING LABORATORY, INC.

DUT: A3LSCHI415; Type: Portable Handset; Serial: 0841-1295

Communication System: GSM850; Frequency: 836.6 MHz; Duty Cycle: 1:8.3

Medium: 835 Head; Medium parameters used (interpolated):

$f = 836.6 \text{ MHz}$; $\sigma = 0.921 \text{ mho/m}$; $\epsilon_r = 41.453$; $\rho = 1000 \text{ kg/m}^3$

Phantom section: Right Section

Test Date: 06-18-2012; Ambient Temp: 24.1°C Tissue Temp: 23.3°C

Probe: ES3DV3 - SN3209; ConvF(6.22, 6.22, 6.22); Calibrated: 3/16/2012

Sensor-Surface: 4mm (Mechanical Surface Detection)

Electronics: DAE4 Sn1323; Calibrated: 2/15/2012

Phantom: SAM Main; Type: SAM 4.0; Serial: TP-1114

Measurement SW: DASY4, Version 4.7 (80);SEMCAD X Version 14.6.4 (4989)

Mode: GSM 850, Right Head, Touch, Mid.ch

Area Scan (7x14x1): Measurement grid: dx=15mm, dy=15mm

Zoom Scan (5x5x7)/Cube 0: Measurement grid: dx=8mm, dy=8mm, dz=5mm

Reference Value = 16.110 V/m; Power Drift = 0.04 dB

Peak SAR (extrapolated) = 0.2650 W/kg

SAR(1 g) = 0.224 mW/g; SAR(10 g) = 0.175 mW/g

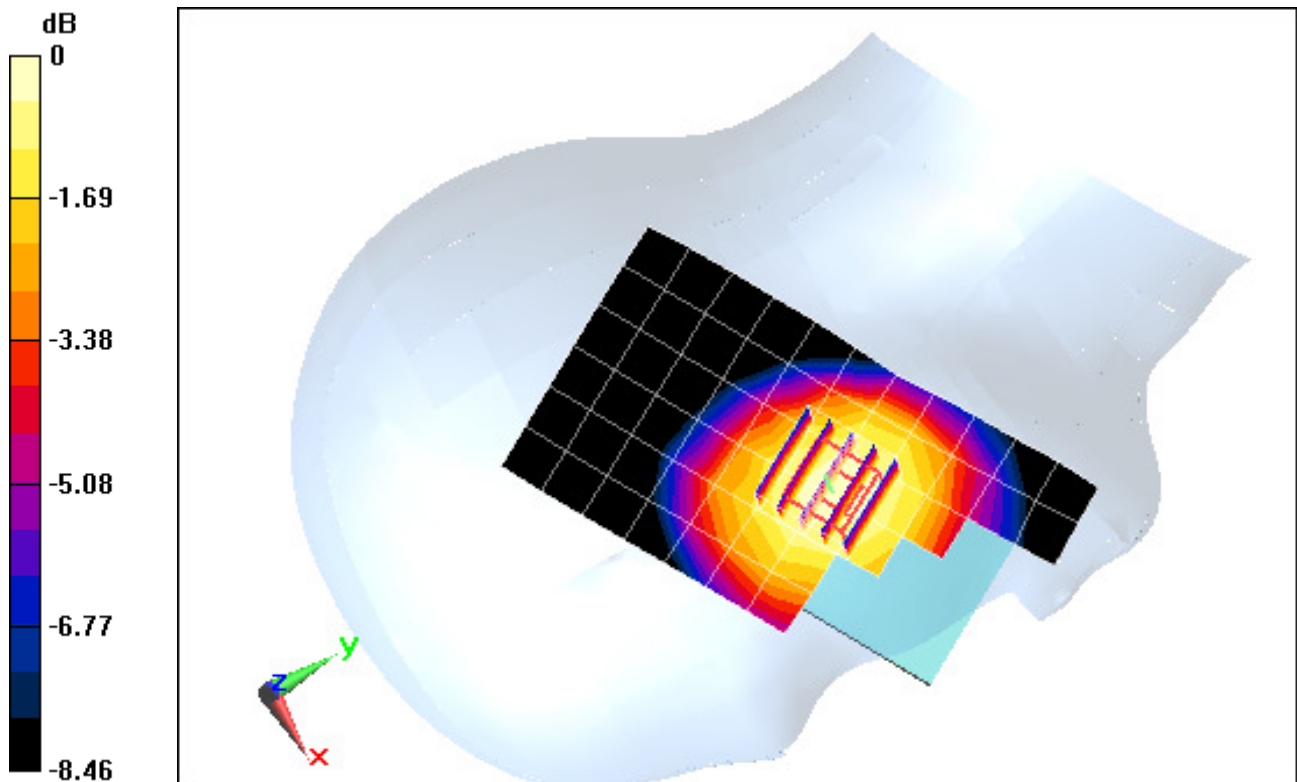

0 dB = 0.240mW/g = -12.40 dB mW/g

PCTEST ENGINEERING LABORATORY, INC.

DUT: A3LSCHI415; Type: Portable Handset; Serial: 0841-1295

Communication System: GSM850; Frequency: 836.6 MHz; Duty Cycle: 1:8.3

Medium: 835 Head; Medium parameters used (interpolated):

$f = 836.6$ MHz; $\sigma = 0.921$ mho/m; $\epsilon_r = 41.453$; $\rho = 1000$ kg/m³

Phantom section: Right Section

Test Date: 06-18-2012; Ambient Temp: 24.1°C; Tissue Temp: 23.3°C

Probe: ES3DV3 - SN3209; ConvF(6.22, 6.22, 6.22); Calibrated: 3/16/2012

Sensor-Surface: 4mm (Mechanical Surface Detection)

Electronics: DAE4 Sn1323; Calibrated: 2/15/2012

Phantom: SAM Main; Type: SAM 4.0; Serial: TP-1114

Measurement SW: DASY4, Version 4.7 (80);SEMCAD X Version 14.6.4 (4989)

Mode: GSM 850, Right Head, Tilt, Mid.ch

Area Scan (7x14x1): Measurement grid: dx=15mm, dy=15mm

Zoom Scan (5x5x7)/Cube 0: Measurement grid: dx=8mm, dy=8mm, dz=5mm

Reference Value = 11.940 V/m; Power Drift = 0.10 dB

Peak SAR (extrapolated) = 0.1460 W/kg

SAR(1 g) = 0.125 mW/g; SAR(10 g) = 0.099 mW/g

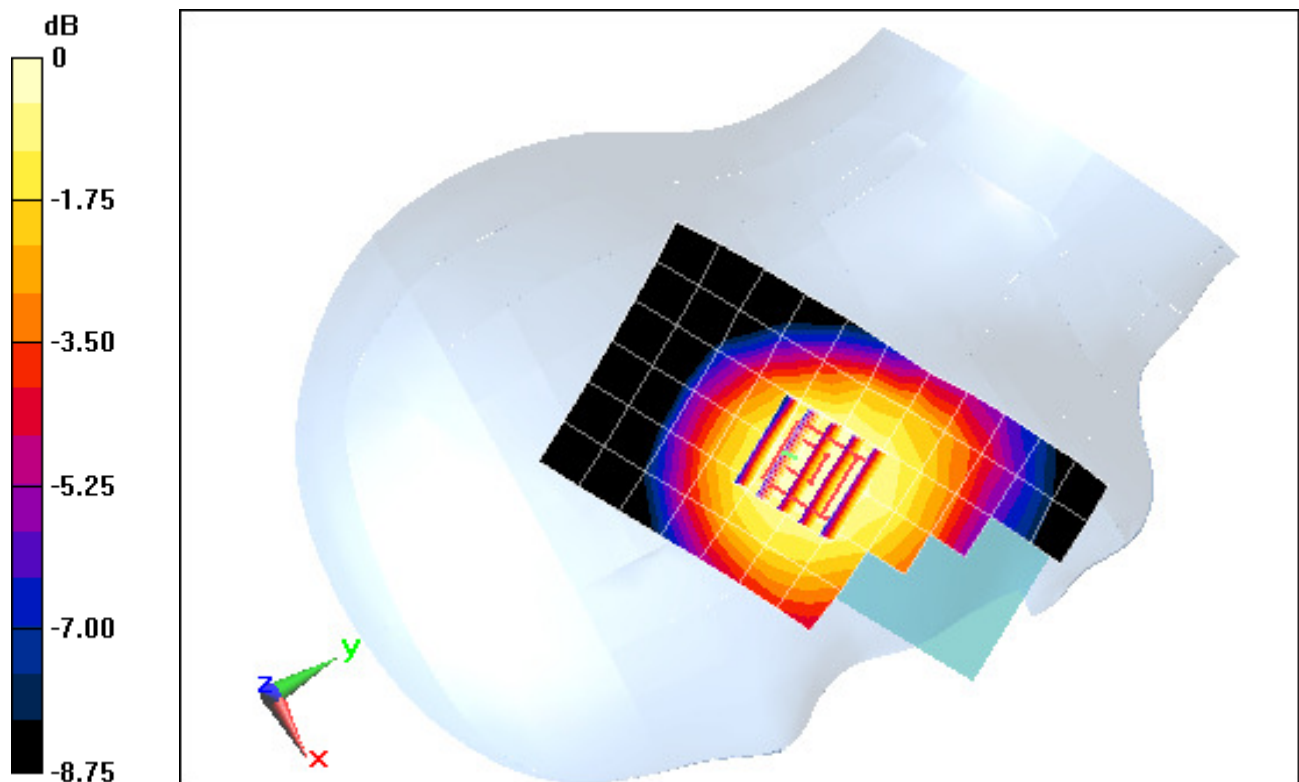

0 dB = 0.130mW/g = -17.72 dB mW/g

PCTEST ENGINEERING LABORATORY, INC.

DUT: A3LSCHI415; Type: Portable Handset; Serial: 0841-1295

Communication System: GSM850; Frequency: 836.6 MHz; Duty Cycle: 1:8.3

Medium: 835 Head; Medium parameters used (interpolated):

$f = 836.6 \text{ MHz}$; $\sigma = 0.921 \text{ mho/m}$; $\epsilon_r = 41.453$; $\rho = 1000 \text{ kg/m}^3$

Phantom section: Left Section

Test Date: 06-18-2012; Ambient Temp: 24.1°C Tissue Temp: 23.3°C

Probe: ES3DV3 - SN3209; ConvF(6.22, 6.22, 6.22); Calibrated: 3/16/2012

Sensor-Surface: 4mm (Mechanical Surface Detection)

Electronics: DAE4 Sn1323; Calibrated: 2/15/2012

Phantom: SAM Main; Type: SAM 4.0; Serial: TP-1114

Measurement SW: DASY4, Version 4.7 (80);SEMCAD X Version 14.6.4 (4989)

Mode: GSM 850, Left Head, Touch, Mid.ch

Area Scan (7x14x1): Measurement grid: dx=15mm, dy=15mm

Zoom Scan (5x5x7)/Cube 0: Measurement grid: dx=8mm, dy=8mm, dz=5mm

Reference Value = 17.664 V/m; Power Drift = -0.01 dB

Peak SAR (extrapolated) = 0.3140 W/kg

SAR(1 g) = 0.261 mW/g; SAR(10 g) = 0.203 mW/g

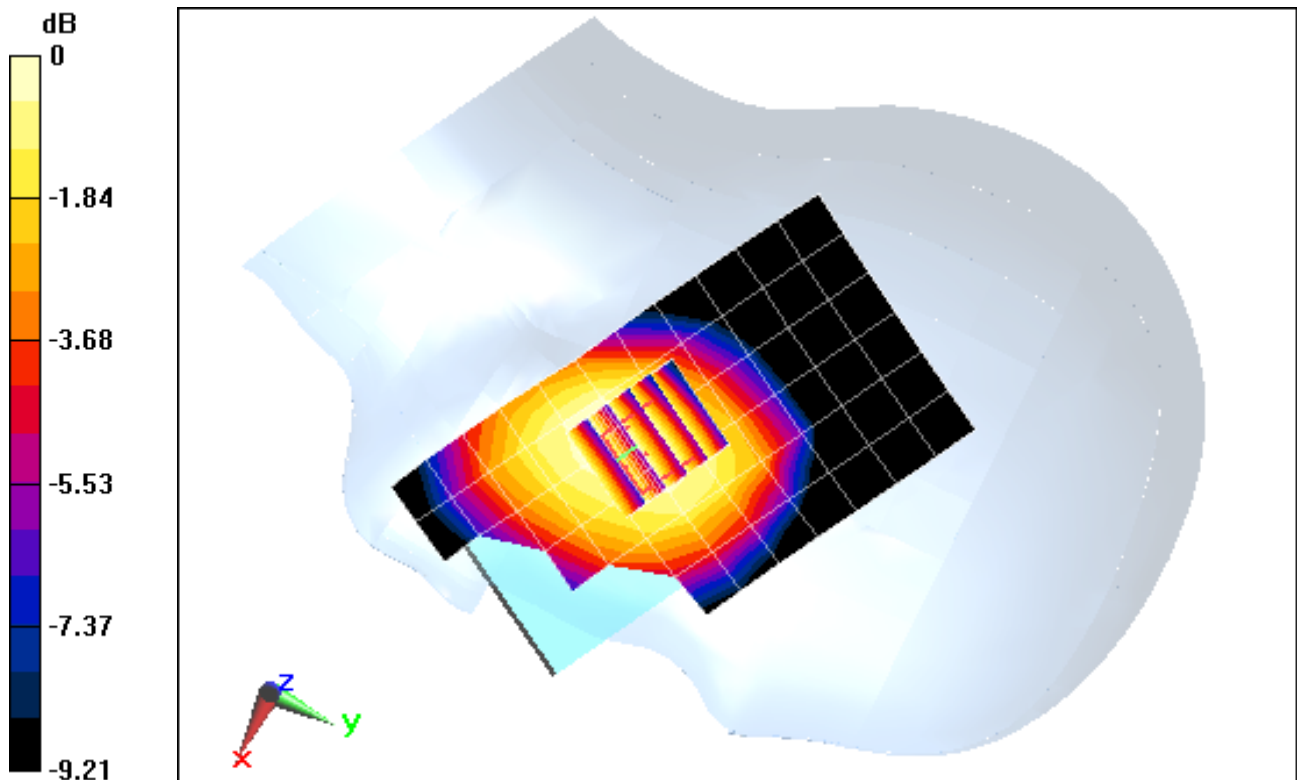

0 dB = 0.270mW/g = -11.37 dB mW/g

PCTEST ENGINEERING LABORATORY, INC.

DUT: A3LSCHI415; Type: Portable Handset; Serial: 0841-1295

Communication System: GSM850; Frequency: 836.6 MHz; Duty Cycle: 1:8.3

Medium: 835 Head; Medium parameters used (interpolated):

$f = 836.6$ MHz; $\sigma = 0.921$ mho/m; $\epsilon_r = 41.453$; $\rho = 1000$ kg/m³

Phantom section: Left Section

Test Date: 06-18-2012; Ambient Temp: 24.1°C Tissue Temp: 23.3°C

Probe: ES3DV3 - SN3209; ConvF(6.22, 6.22, 6.22); Calibrated: 3/16/2012

Sensor-Surface: 4mm (Mechanical Surface Detection)

Electronics: DAE4 Sn1323; Calibrated: 2/15/2012

Phantom: SAM Main; Type: SAM 4.0; Serial: TP-1114

Measurement SW: DASY4, Version 4.7 (80);SEMCAD X Version 14.6.4 (4989)

Mode: GSM 850, Left Head, Tilt, Mid.ch

Area Scan (7x14x1): Measurement grid: dx=15mm, dy=15mm

Zoom Scan (5x5x7)/Cube 0: Measurement grid: dx=8mm, dy=8mm, dz=5mm

Reference Value = 12.582 V/m; Power Drift = 0.04 dB

Peak SAR (extrapolated) = 0.1630 W/kg

SAR(1 g) = 0.137 mW/g; SAR(10 g) = 0.107 mW/g

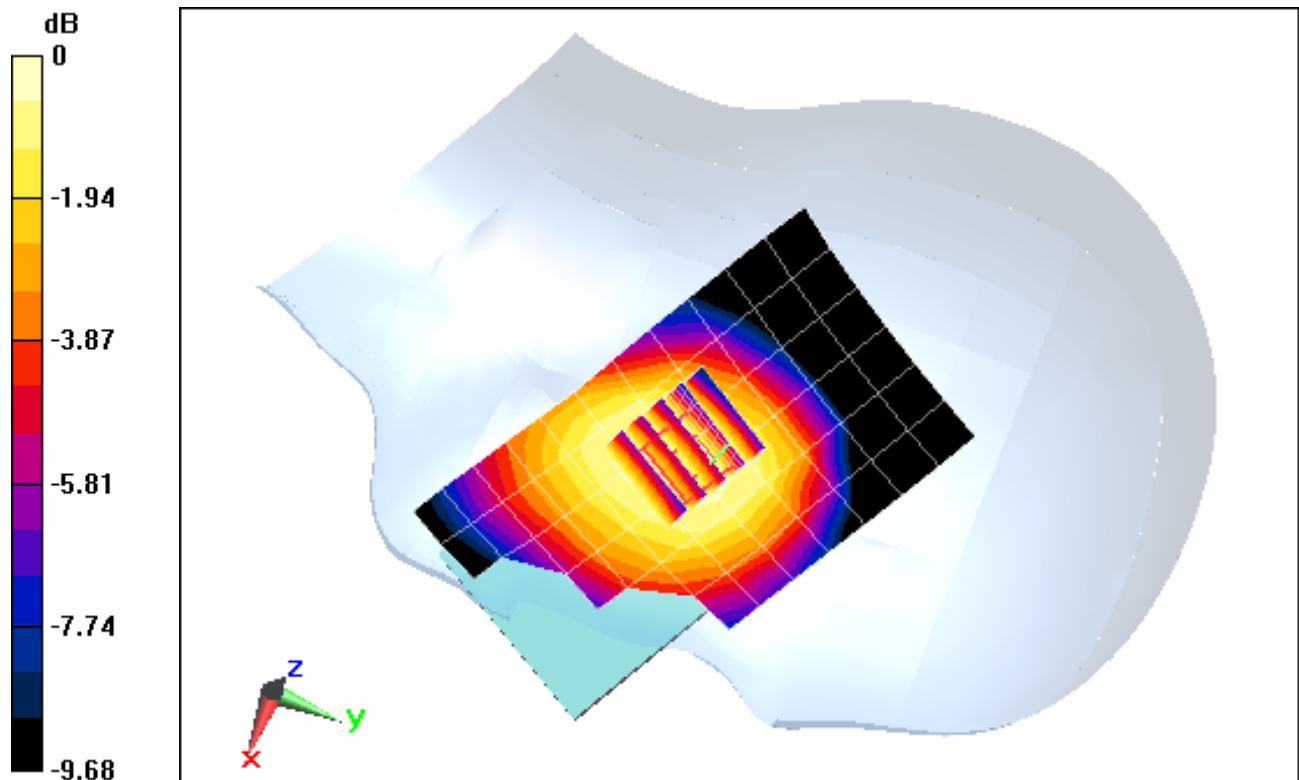

0 dB = 0.140mW/g = -17.08 dB mW/g

PCTEST ENGINEERING LABORATORY, INC.

DUT: A3LSCHI415; Type: Portable Handset; Serial: 0841-1297

Communication System: CDMA; Frequency: 1880 MHz; Duty Cycle: 1:1
Medium: 1900 Head; Medium parameters used:

$f = 1880 \text{ MHz}$; $\sigma = 1.37 \text{ mho/m}$; $\epsilon_r = 38.36$; $\rho = 1000 \text{ kg/m}^3$

Phantom section: Right Section

Test Date: 06-04-2012; Ambient Temp: 23.9°C; Tissue Temp: 22.1°C

Probe: ES3DV3 - SN3288; ConvF(5.16, 5.16, 5.16); Calibrated: 2/7/2012
Sensor-Surface: 4mm (Mechanical Surface Detection)

Electronics: DAE4 Sn1333; Calibrated: 4/12/2012

Phantom: SAM V5.0 Right; Type: QD000P40CD; Serial: 1647

Measurement SW: DASY52, Version 52.8 (0); SEMCAD X Version 14.6.4 (4989)

Mode: PCS CDMA, Right Head, Touch, Mid.ch

Area Scan (7x12x1): Measurement grid: dx=15mm, dy=15mm

Zoom Scan (5x5x7)/Cube 0: Measurement grid: dx=8mm, dy=8mm, dz=5mm

Reference Value = 12.010 V/m; Power Drift = 0.10 dB

Peak SAR (extrapolated) = 0.3130 W/kg

SAR(1 g) = 0.201 mW/g; SAR(10 g) = 0.125 mW/g

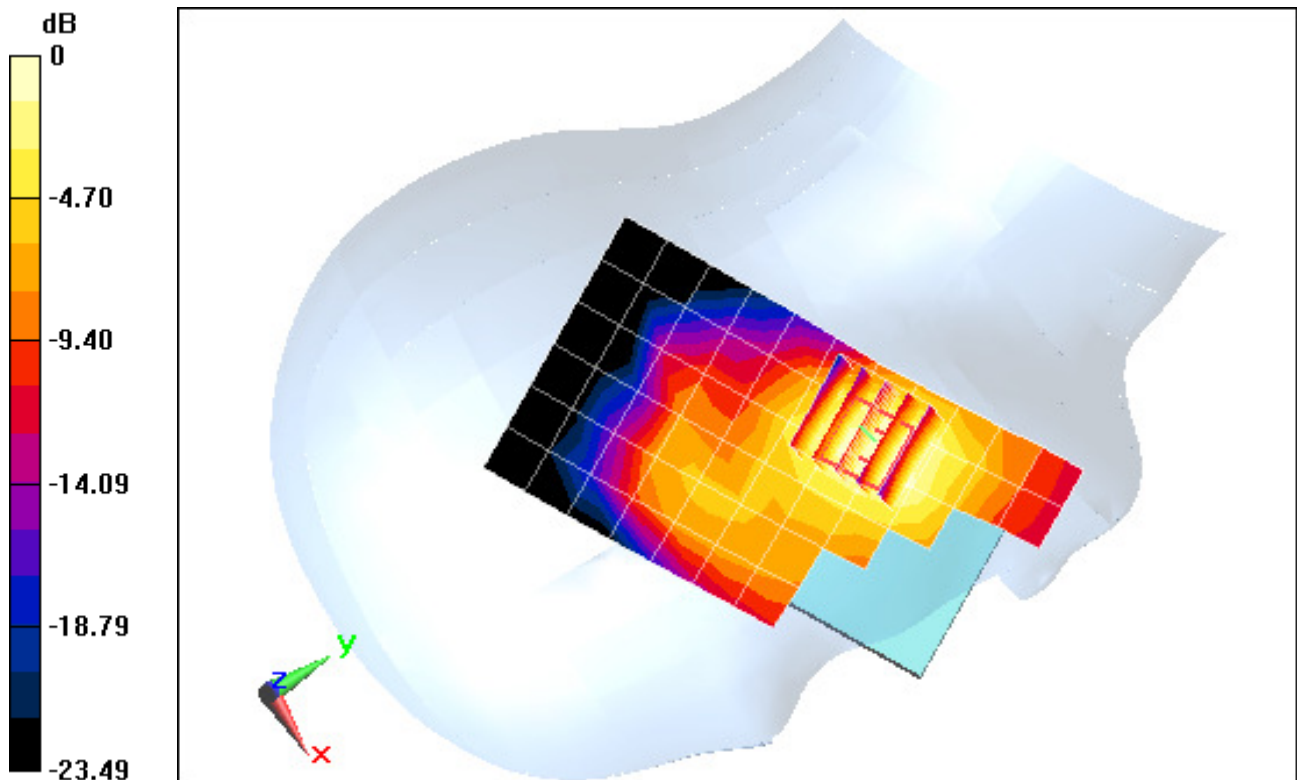

0 dB = 0.220mW/g = -13.15 dB mW/g

PCTEST ENGINEERING LABORATORY, INC.

DUT: A3LSCHI415; Type: Portable Handset; Serial: 0841-1297

Communication System: CDMA; Frequency: 1880 MHz; Duty Cycle: 1:1
Medium: 1900 Head; Medium parameters used:

$f = 1880 \text{ MHz}$; $\sigma = 1.37 \text{ mho/m}$; $\epsilon_r = 38.36$; $\rho = 1000 \text{ kg/m}^3$

Phantom section: Right Section

Test Date: 06-04-2012; Ambient Temp: 23.9°C; Tissue Temp: 22.1°C

Probe: ES3DV3 - SN3288; ConvF(5.16, 5.16, 5.16); Calibrated: 2/7/2012
Sensor-Surface: 4mm (Mechanical Surface Detection)

Electronics: DAE4 Sn1333; Calibrated: 4/12/2012

Phantom: SAM V5.0 Right; Type: QD000P40CD; Serial: 1647

Measurement SW: DASY52, Version 52.8 (0);SEMCAD X Version 14.6.4 (4989)

Mode: PCS CDMA, Right Head, Tilt, Mid.ch

Area Scan (7x12x1): Measurement grid: dx=15mm, dy=15mm

Zoom Scan (5x5x7)/Cube 0: Measurement grid: dx=8mm, dy=8mm, dz=5mm

Reference Value = 6.749 V/m; Power Drift = -0.17 dB

Peak SAR (extrapolated) = 0.0840 W/kg

SAR(1 g) = 0.054 mW/g; SAR(10 g) = 0.032 mW/g

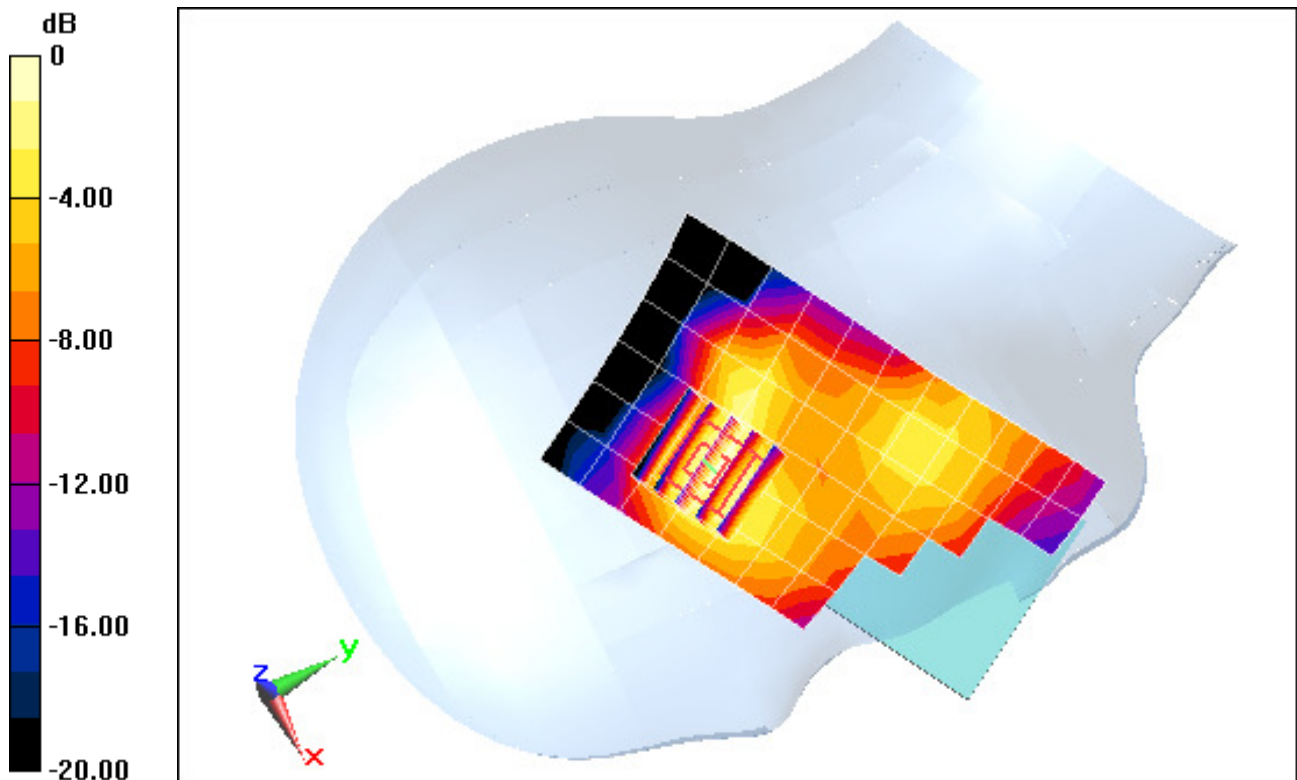

0 dB = 0.060mW/g = -24.44 dB mW/g

PCTEST ENGINEERING LABORATORY, INC.

DUT: A3LSCHI415; Type: Portable Handset; Serial: 0841-1297

Communication System: CDMA; Frequency: 1880 MHz; Duty Cycle: 1:1
Medium: 1900 Head; Medium parameters used:

$f = 1880 \text{ MHz}$; $\sigma = 1.37 \text{ mho/m}$; $\epsilon_r = 38.36$; $\rho = 1000 \text{ kg/m}^3$

Phantom section: Left Section

Test Date: 06-04-2012; Ambient Temp: 23.9°C; Tissue Temp: 22.1°C

Probe: ES3DV3 - SN3288; ConvF(5.16, 5.16, 5.16); Calibrated: 2/7/2012
Sensor-Surface: 4mm (Mechanical Surface Detection)

Electronics: DAE4 Sn1333; Calibrated: 4/12/2012

Phantom: SAM V5.0 Right; Type: QD000P40CD; Serial: 1647

Measurement SW: DASY52, Version 52.8 (0);SEMCAD X Version 14.6.4 (4989)

Mode: PCS CDMA, Left Head, Touch, Mid.ch

Area Scan (7x14x1): Measurement grid: dx=15mm, dy=15mm

Zoom Scan (5x5x7)/Cube 0: Measurement grid: dx=8mm, dy=8mm, dz=5mm

Reference Value = 8.969 V/m; Power Drift = 0.06 dB

Peak SAR (extrapolated) = 0.1610 W/kg

SAR(1 g) = 0.101 mW/g; SAR(10 g) = 0.061 mW/g

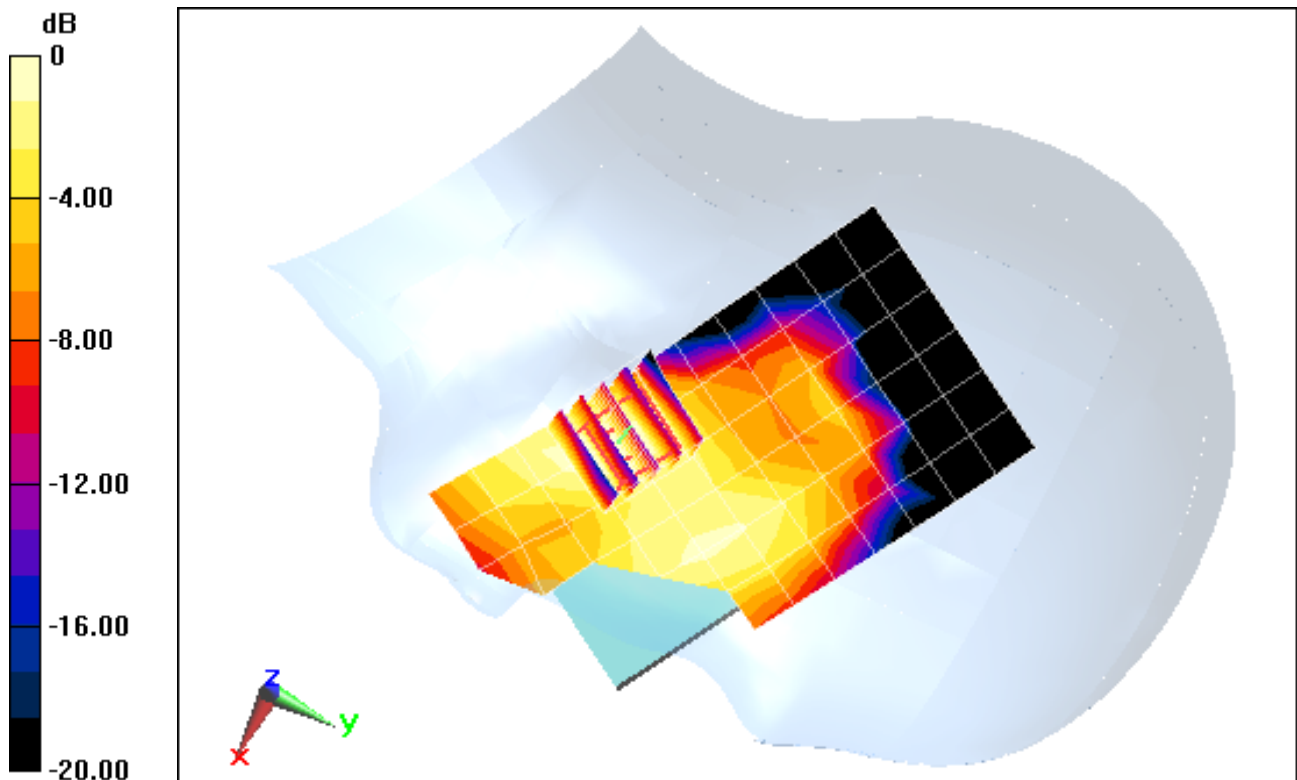

0 dB = 0.110mW/g = -19.17 dB mW/g

PCTEST ENGINEERING LABORATORY, INC.

DUT: A3LSCHI415; Type: Portable Handset; Serial: 0841-1297

Communication System: CDMA; Frequency: 1880 MHz; Duty Cycle: 1:1
Medium: 1900 Head; Medium parameters used:

$f = 1880 \text{ MHz}$; $\sigma = 1.37 \text{ mho/m}$; $\epsilon_r = 38.36$; $\rho = 1000 \text{ kg/m}^3$

Phantom section: Left Section

Test Date: 06-04-2012; Ambient Temp: 23.9°C; Tissue Temp: 22.1°C

Probe: ES3DV3 - SN3288; ConvF(5.16, 5.16, 5.16); Calibrated: 2/7/2012
Sensor-Surface: 4mm (Mechanical Surface Detection)

Electronics: DAE4 Sn1333; Calibrated: 4/12/2012

Phantom: SAM V5.0 Right; Type: QD000P40CD; Serial: 1647

Measurement SW: DASY52, Version 52.8 (0);SEMCAD X Version 14.6.4 (4989)

Mode: PCS CDMA, Left Head, Tilt, Mid.ch

Area Scan (7x12x1): Measurement grid: dx=15mm, dy=15mm

Zoom Scan (5x5x7)/Cube 0: Measurement grid: dx=8mm, dy=8mm, dz=5mm

Reference Value = 5.398 V/m; Power Drift = 0.024 dB

Peak SAR (extrapolated) = 0.0610 W/kg

SAR(1 g) = 0.037 mW/g; SAR(10 g) = 0.020 mW/g

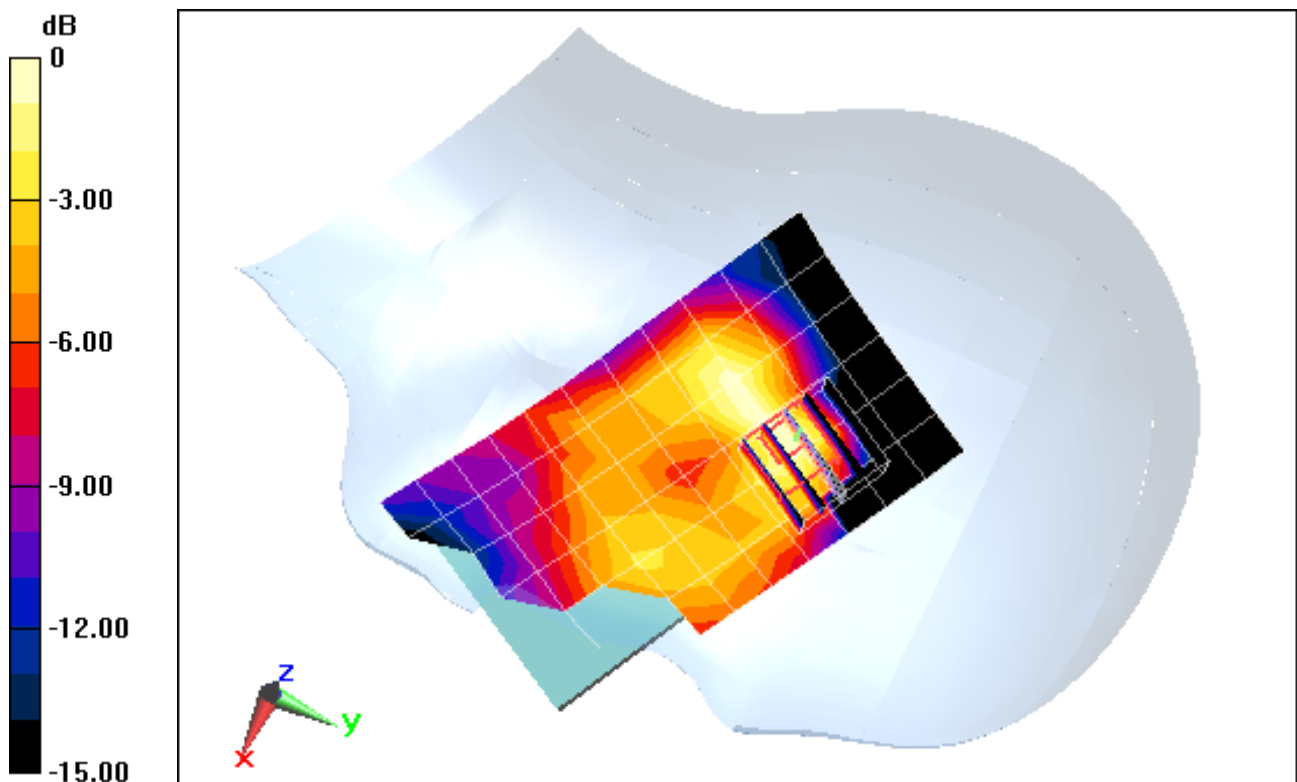

0 dB = 0.040mW/g = -27.96 dB mW/g

PCTEST ENGINEERING LABORATORY, INC.

DUT: A3LSCHI415; Type: Portable Handset; Serial: 0841-1299

Communication System: GSM1900; Frequency: 1880 MHz; Duty Cycle: 1:8.3

Medium: 1900 Head; Medium parameters used:

$f = 1880 \text{ MHz}$; $\sigma = 1.423 \text{ mho/m}$; $\epsilon_r = 39.4$; $\rho = 1000 \text{ kg/m}^3$

Phantom section: Right Section

Test Date: 06-11-2012; Ambient Temp: 22.9°C; Tissue Temp: 21.6°C

Probe: ES3DV2 - SN3022; ConvF(4.98, 4.98, 4.98); Calibrated: 8/25/2011

Sensor-Surface: 4mm (Mechanical Surface Detection)

Electronics: DAE4 Sn665; Calibrated: 4/19/2012

Phantom: SAM with CRP; Type: SAM; Serial: TP1375

Measurement SW: DASY4, Version 4.7 (80); SEMCAD X Version 14.6.4 (4989)

Mode: GSM 1900, Right Head, Touch, Mid.ch

Area Scan (7x14x1): Measurement grid: dx=15mm, dy=15mm

Zoom Scan (5x5x7)/Cube 0: Measurement grid: dx=8mm, dy=8mm, dz=5mm

Reference Value = 10.385 V/m; Power Drift = -0.20 dB

Peak SAR (extrapolated) = 0.2270 W/kg

SAR(1 g) = 0.148 mW/g; SAR(10 g) = 0.092 mW/g

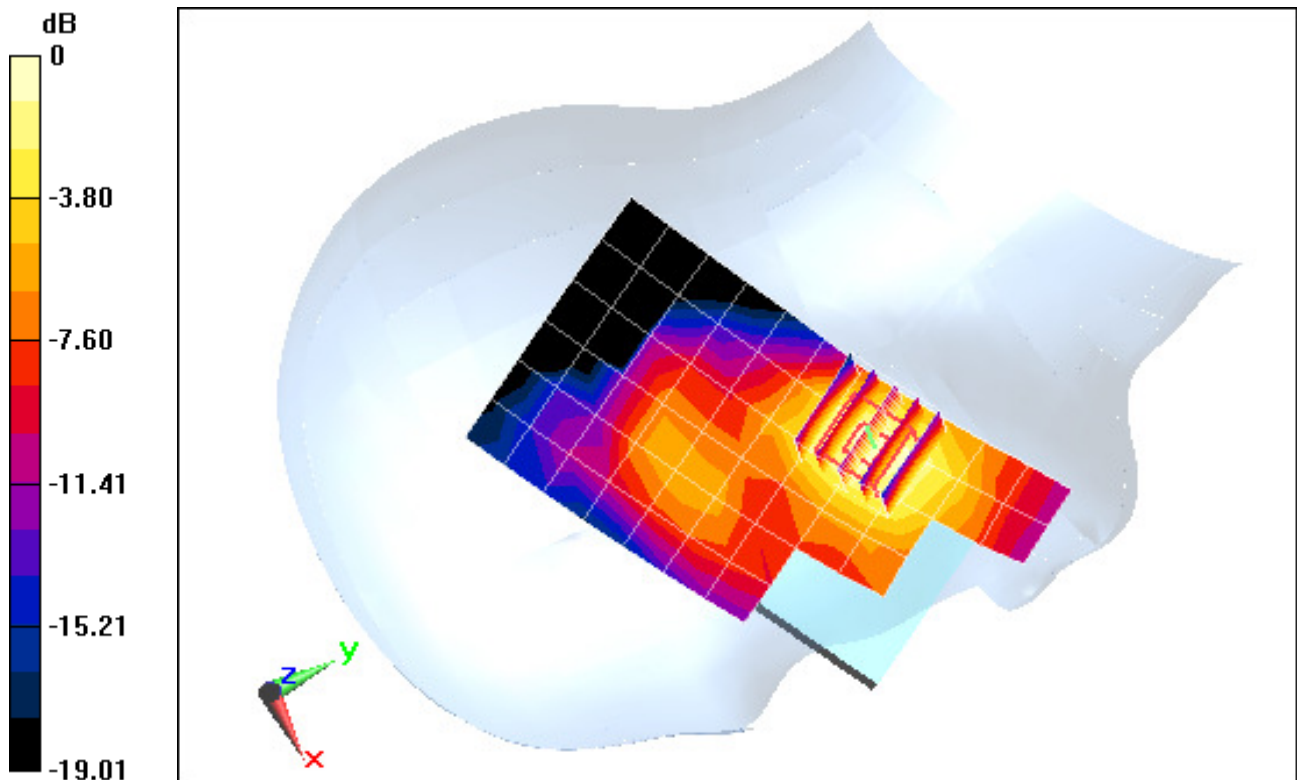

0 dB = 0.160mW/g = -15.92 dB mW/g

PCTEST ENGINEERING LABORATORY, INC.

DUT: A3LSCHI415; Type: Portable Handset; Serial: 0841-1299

Communication System: GSM1900; Frequency: 1880 MHz; Duty Cycle: 1:8.3

Medium: 1900 Head; Medium parameters used:

$f = 1880 \text{ MHz}$; $\sigma = 1.423 \text{ mho/m}$; $\epsilon_r = 39.4$; $\rho = 1000 \text{ kg/m}^3$

Phantom section: Right Section

Test Date: 06-11-2012; Ambient Temp: 22.9°C; Tissue Temp: 21.6°C

Probe: ES3DV2 - SN3022; ConvF(4.98, 4.98, 4.98); Calibrated: 8/25/2011

Sensor-Surface: 4mm (Mechanical Surface Detection)

Electronics: DAE4 Sn665; Calibrated: 4/19/2012

Phantom: SAM with CRP; Type: SAM; Serial: TP1375

Measurement SW: DASY4, Version 4.7 (80); SEMCAD X Version 14.6.4 (4989)

Mode: GSM 1900, Right Head, Tilt, Mid.ch

Area Scan (7x14x1): Measurement grid: dx=15mm, dy=15mm

Zoom Scan (5x5x7)/Cube 0: Measurement grid: dx=8mm, dy=8mm, dz=5mm

Reference Value = 5.745 V/m; Power Drift = -0.0051 dB

Peak SAR (extrapolated) = 0.0680 W/kg

SAR(1 g) = 0.045 mW/g; SAR(10 g) = 0.028 mW/g

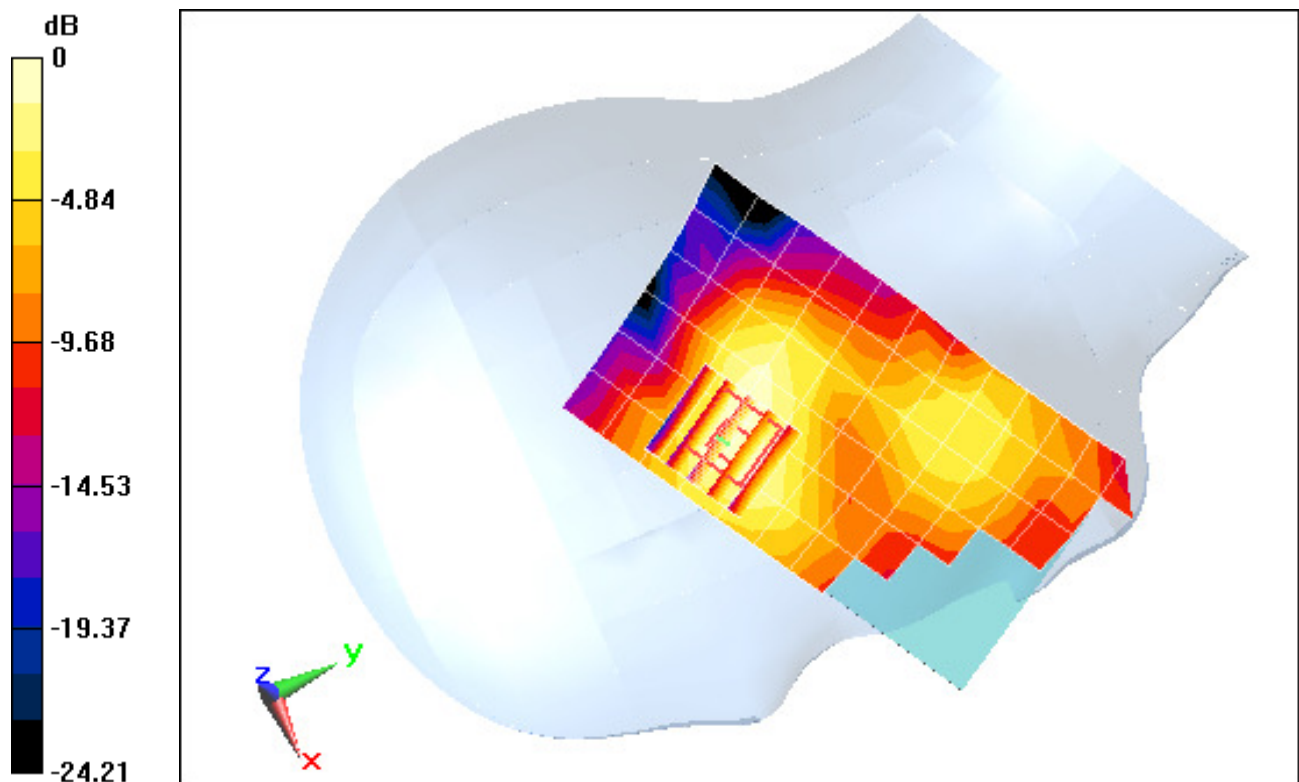

0 dB = 0.050mW/g = -26.02 dB mW/g

PCTEST ENGINEERING LABORATORY, INC.

DUT: A3LSCHI415; Type: Portable Handset; Serial: 0841-1299

Communication System: GSM1900; Frequency: 1880 MHz; Duty Cycle: 1:8.3

Medium: 1900 Head; Medium parameters used:

$f = 1880 \text{ MHz}$; $\sigma = 1.423 \text{ mho/m}$; $\epsilon_r = 39.4$; $\rho = 1000 \text{ kg/m}^3$

Phantom section: Left Section

Test Date: 06-11-2012; Ambient Temp: 22.9°C; Tissue Temp: 21.6°C

Probe: ES3DV2 - SN3022; ConvF(4.98, 4.98, 4.98); Calibrated: 8/25/2011

Sensor-Surface: 4mm (Mechanical Surface Detection)

Electronics: DAE4 Sn665; Calibrated: 4/19/2012

Phantom: SAM with CRP; Type: SAM; Serial: TP1375

Measurement SW: DASY4, Version 4.7 (80);SEMCAD X Version 14.6.4 (4989)

Mode: GSM 1900, Left Head, Touch, Mid.ch

Area Scan (7x14x1): Measurement grid: dx=15mm, dy=15mm

Zoom Scan (5x5x7)/Cube 0: Measurement grid: dx=8mm, dy=8mm, dz=5mm

Reference Value = 7.963 V/m; Power Drift = -0.13 dB

Peak SAR (extrapolated) = 0.1200 W/kg

SAR(1 g) = 0.083 mW/g; SAR(10 g) = 0.054 mW/g

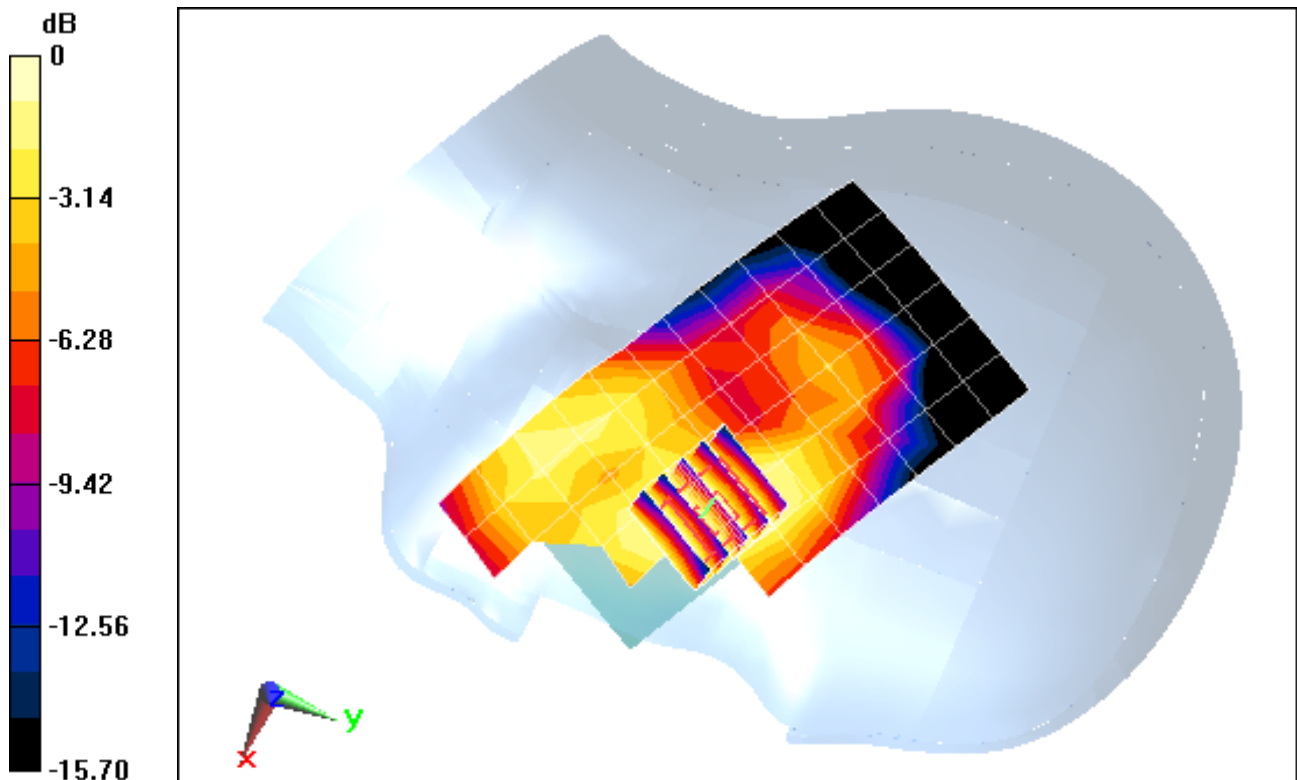

0 dB = 0.090mW/g = -20.92 dB mW/g

PCTEST ENGINEERING LABORATORY, INC.

DUT: A3LSCHI415; Type: Portable Handset; Serial: 0841-1299

Communication System: GSM1900; Frequency: 1880 MHz; Duty Cycle: 1:8.3

Medium: 1900 Head; Medium parameters used:

$f = 1880 \text{ MHz}$; $\sigma = 1.423 \text{ mho/m}$; $\epsilon_r = 39.4$; $\rho = 1000 \text{ kg/m}^3$

Phantom section: Left Section

Test Date: 06-11-2012; Ambient Temp: 22.9°C; Tissue Temp: 21.6°C

Probe: ES3DV2 - SN3022; ConvF(4.98, 4.98, 4.98); Calibrated: 8/25/2011

Sensor-Surface: 4mm (Mechanical Surface Detection)

Electronics: DAE4 Sn665; Calibrated: 4/19/2012

Phantom: SAM with CRP; Type: SAM; Serial: TP1375

Measurement SW: DASY4, Version 4.7 (80);SEMCAD X Version 14.6.4 (4989)

Mode: GSM 1900, Left Head, Tilt, Mid.ch

Area Scan (7x14x1): Measurement grid: $dx=15\text{mm}$, $dy=15\text{mm}$

Zoom Scan (5x5x7)/Cube 0: Measurement grid: $dx=8\text{mm}$, $dy=8\text{mm}$, $dz=5\text{mm}$

Reference Value = 5.527 V/m; Power Drift = -0.12 dB

Peak SAR (extrapolated) = 0.0740 W/kg

SAR(1 g) = 0.045 mW/g; SAR(10 g) = 0.026 mW/g

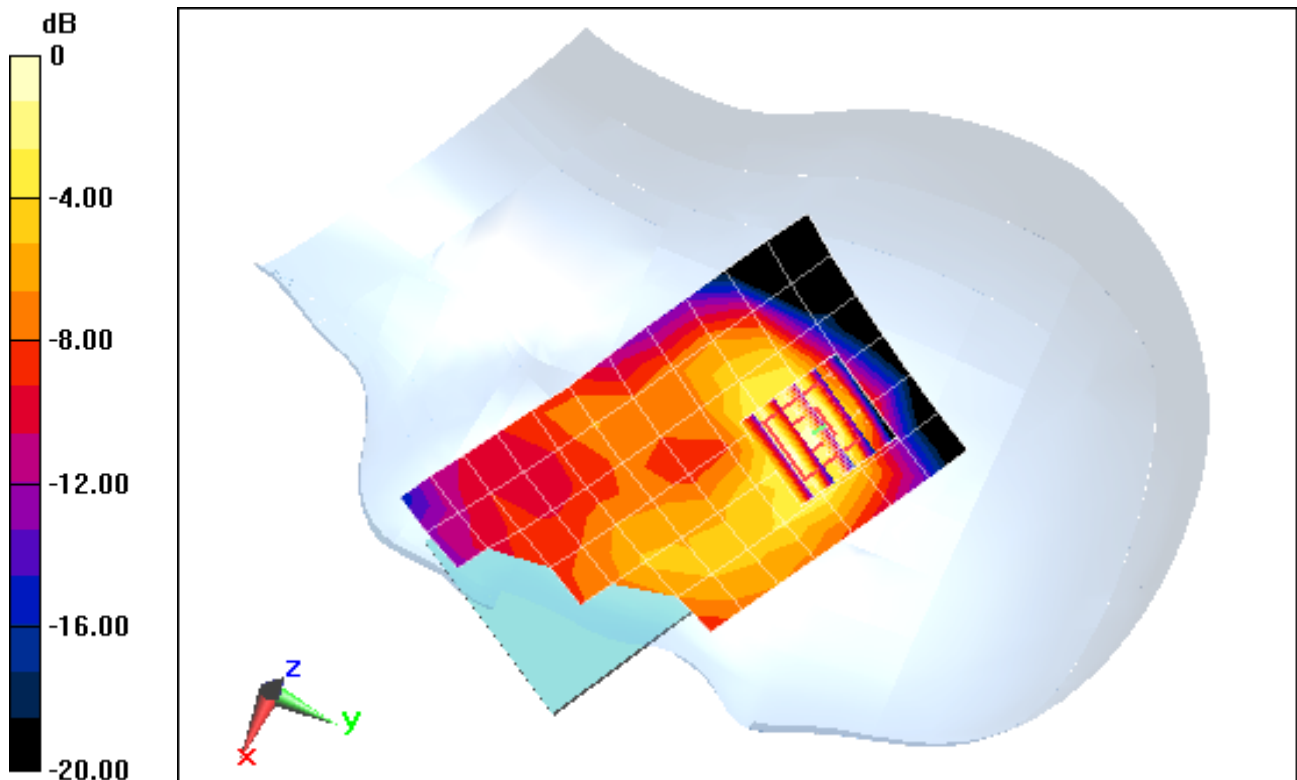

0 dB = 0.050mW/g = -26.02 dB mW/g

PCTEST ENGINEERING LABORATORY, INC.

DUT: A3LSCHI415; Type: Portable Handset; Serial: 0841-1295

Communication System: IEEE 802.11b; Frequency: 2412 MHz; Duty Cycle: 1:1
Medium: 2450 Head; Medium parameters used (interpolated):

$f = 2412 \text{ MHz}$; $\sigma = 1.76 \text{ mho/m}$; $\epsilon_r = 37.476$; $\rho = 1000 \text{ kg/m}^3$

Phantom section: Right Section

Test Date: 06-19-2012; Ambient Temp: 24.4°C; Tissue Temp: 22.9°C

Probe: ES3DV3 - SN3258; ConvF(4.46, 4.46, 4.46); Calibrated: 2/21/2012

Sensor-Surface: 3mm (Mechanical Surface Detection)

Electronics: DAE4 Sn1272; Calibrated: 1/18/2012

Phantom: SAM Sub; Type: SAM 4.0; Serial: TP-1403

Measurement SW: DASY4, Version 4.7 (80);SEMCAD X Version 14.6.4 (4989)

Mode: IEEE 802.11b, Right Head, Touch, Ch 01, 1 Mbps

Area Scan (10x17x1): Measurement grid: dx=12mm, dy=12mm

Zoom Scan (7x7x7)/Cube 0: Measurement grid: dx=5mm, dy=5mm, dz=5mm

Reference Value = 5.013 V/m; Power Drift = -0.18 dB

Peak SAR (extrapolated) = 0.0800 W/kg

SAR(1 g) = 0.041 mW/g; SAR(10 g) = 0.021 mW/g

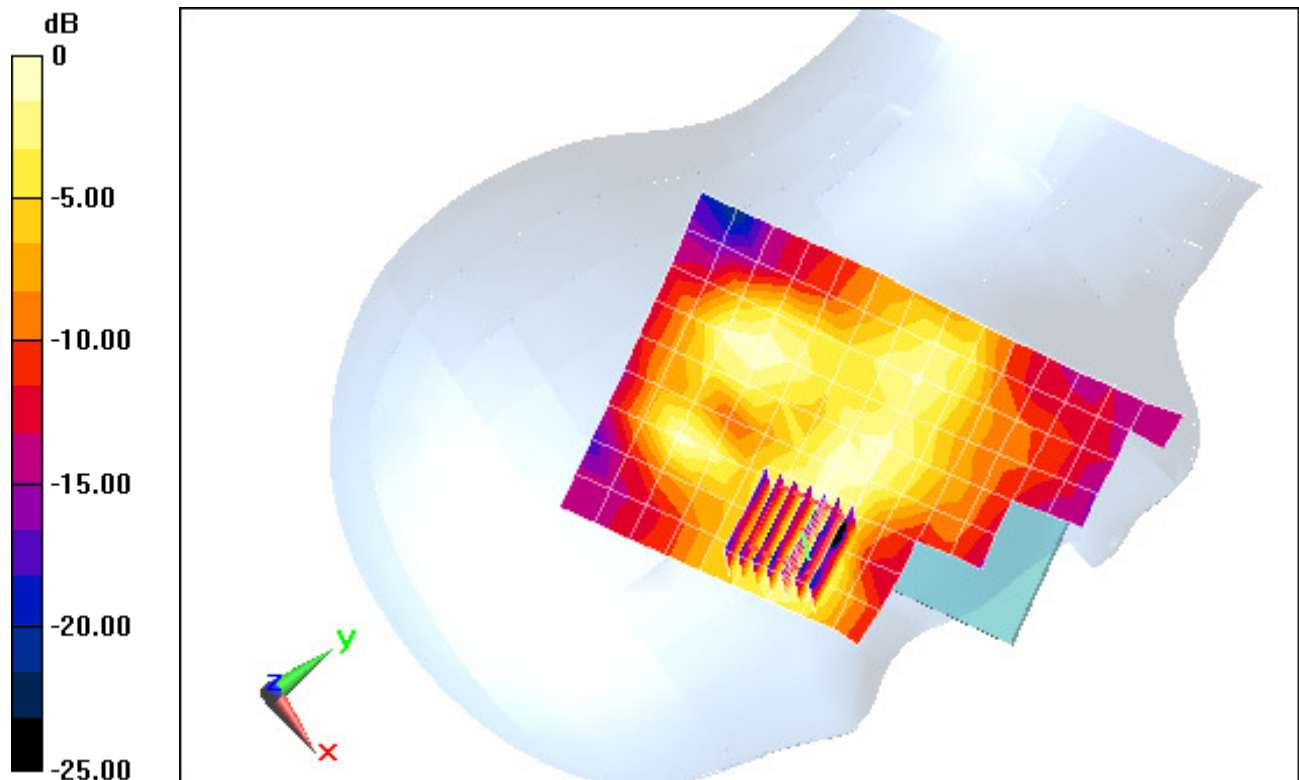

0 dB = 0.050mW/g = -26.02 dB mW/g

PCTEST ENGINEERING LABORATORY, INC.

DUT: A3LSCHI415; Type: Portable Handset; Serial: 0841-1295

Communication System: IEEE 802.11b; Frequency: 2412 MHz; Duty Cycle: 1:1
Medium: 2450 Head; Medium parameters used (interpolated):

$f = 2412 \text{ MHz}$; $\sigma = 1.76 \text{ mho/m}$; $\epsilon_r = 37.476$; $\rho = 1000 \text{ kg/m}^3$

Phantom section: Right Section

Test Date: 06-19-2012; Ambient Temp: 24.4°C; Tissue Temp: 22.9°C

Probe: ES3DV3 - SN3258; ConvF(4.46, 4.46, 4.46); Calibrated: 2/21/2012

Sensor-Surface: 3mm (Mechanical Surface Detection)

Electronics: DAE4 Sn1272; Calibrated: 1/18/2012

Phantom: SAM Sub; Type: SAM 4.0; Serial: TP-1403

Measurement SW: DASY4, Version 4.7 (80);SEMCAD X Version 14.6.4 (4989)

Mode: IEEE 802.11b, Right Head, Tilt, Ch 01, 1 Mbps

Area Scan (10x17x1): Measurement grid: dx=12mm, dy=12mm

Zoom Scan (7x7x7)/Cube 0: Measurement grid: dx=5mm, dy=5mm, dz=5mm

Reference Value = 5.602 V/m; Power Drift = -0.00096 dB

Peak SAR (extrapolated) = 0.0950 W/kg

SAR(1 g) = 0.052 mW/g; SAR(10 g) = 0.025 mW/g

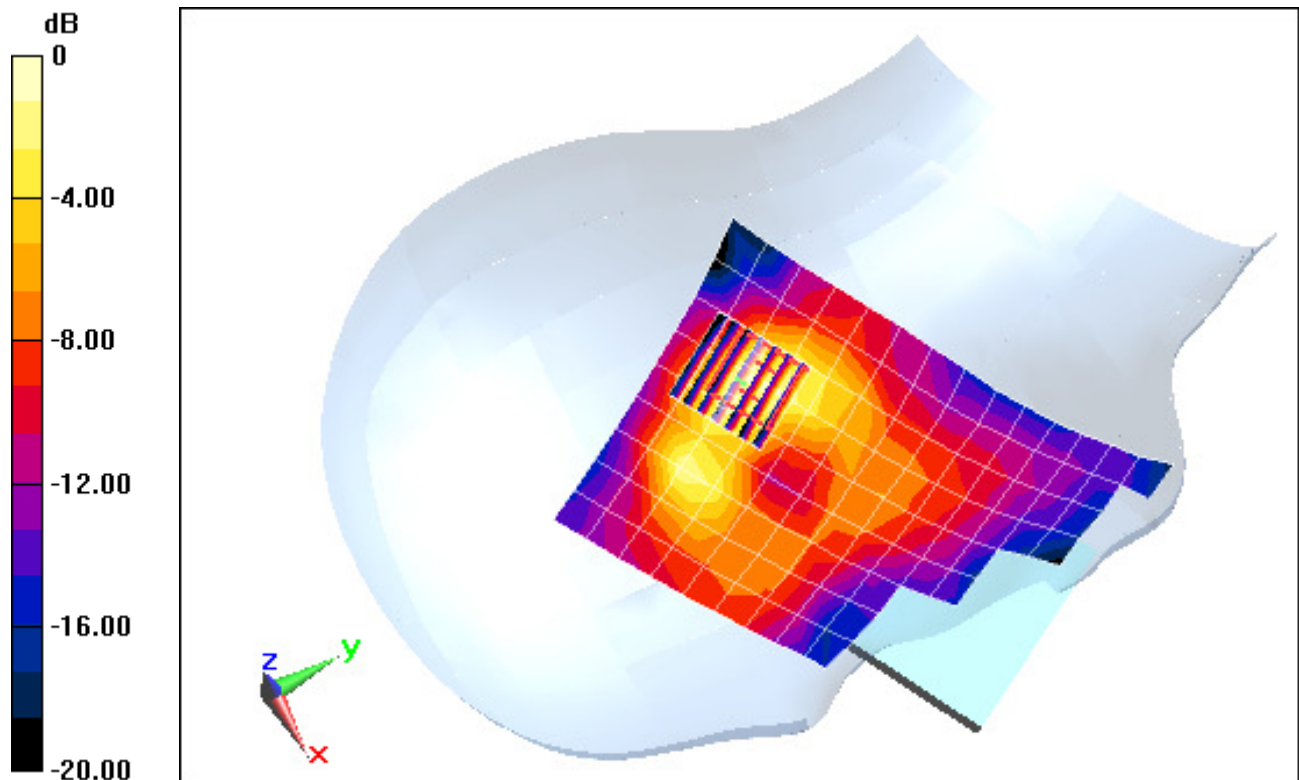

0 dB = 0.070mW/g = -23.10 dB mW/g

PCTEST ENGINEERING LABORATORY, INC.

DUT: A3LSCHI415; Type: Portable Handset; Serial: 0841-1295

Communication System: IEEE 802.11b; Frequency: 2412 MHz; Duty Cycle: 1:1

Medium: 2450 Head; Medium parameters used (interpolated):

$f = 2412$ MHz; $\sigma = 1.76$ mho/m; $\epsilon_r = 37.476$; $\rho = 1000$ kg/m³

Phantom section: Left Section

Test Date: 06-19-2012; Ambient Temp: 24.4°C; Tissue Temp: 22.9°C

Probe: ES3DV3 - SN3258; ConvF(4.46, 4.46, 4.46); Calibrated: 2/21/2012

Sensor-Surface: 3mm (Mechanical Surface Detection)

Electronics: DAE4 Sn1272; Calibrated: 1/18/2012

Phantom: SAM Sub; Type: SAM 4.0; Serial: TP-1403

Measurement SW: DASY4, Version 4.7 (80);SEMCAD X Version 14.6.4 (4989)

Mode: IEEE 802.11b, Left Head, Touch, Ch 01, 1 Mbps

Area Scan (10x15x1): Measurement grid: dx=12mm, dy=12mm

Zoom Scan (7x7x7)/Cube 0: Measurement grid: dx=5mm, dy=5mm, dz=5mm

Reference Value = 5.646 V/m; Power Drift = -0.14 dB

Peak SAR (extrapolated) = 0.1260 W/kg

SAR(1 g) = 0.058 mW/g; SAR(10 g) = 0.025 mW/g

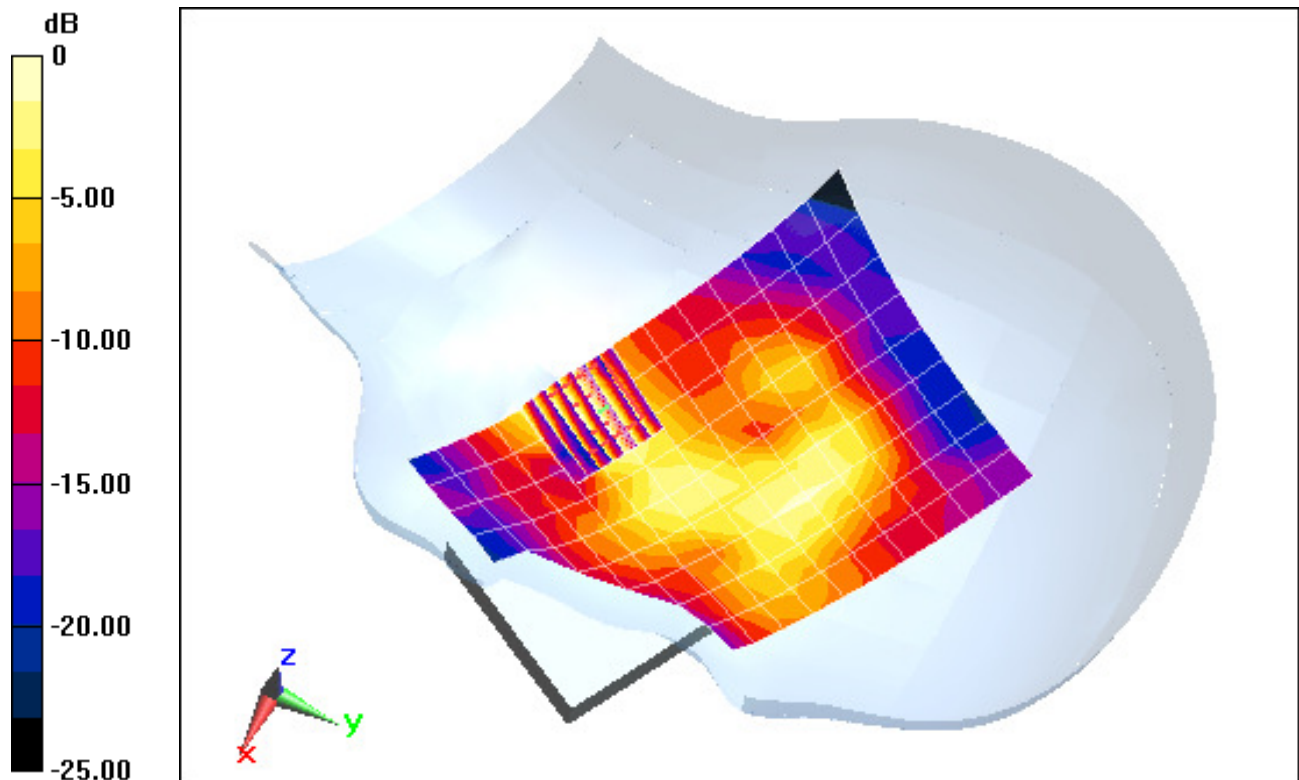

0 dB = 0.070mW/g = -23.10 dB mW/g

PCTEST ENGINEERING LABORATORY, INC.

DUT: A3LSCHI415; Type: Portable Handset; Serial: 0841-1295

Communication System: IEEE 802.11b; Frequency: 2412 MHz; Duty Cycle: 1:1
Medium: 2450 Head; Medium parameters used (interpolated):

$f = 2412 \text{ MHz}$; $\sigma = 1.76 \text{ mho/m}$; $\epsilon_r = 37.476$; $\rho = 1000 \text{ kg/m}^3$

Phantom section: Left Section

Test Date: 06-19-2012; Ambient Temp: 24.4°C; Tissue Temp: 22.9°C

Probe: ES3DV3 - SN3258; ConvF(4.46, 4.46, 4.46); Calibrated: 2/21/2012
Sensor-Surface: 3mm (Mechanical Surface Detection)

Electronics: DAE4 Sn1272; Calibrated: 1/18/2012

Phantom: SAM Sub; Type: SAM 4.0; Serial: TP-1403

Measurement SW: DASY4, Version 4.7 (80);SEMCAD X Version 14.6.4 (4989)

Mode: IEEE 802.11b, Left Head, Tilt, Ch 01, 1 Mbps

Area Scan (10x15x1): Measurement grid: dx=12mm, dy=12mm

Zoom Scan (7x7x7)/Cube 0: Measurement grid: dx=5mm, dy=5mm, dz=5mm

Reference Value = 6.336 V/m; Power Drift = 0.08 dB

Peak SAR (extrapolated) = 0.1190 W/kg

SAR(1 g) = 0.066 mW/g; SAR(10 g) = 0.034 mW/g

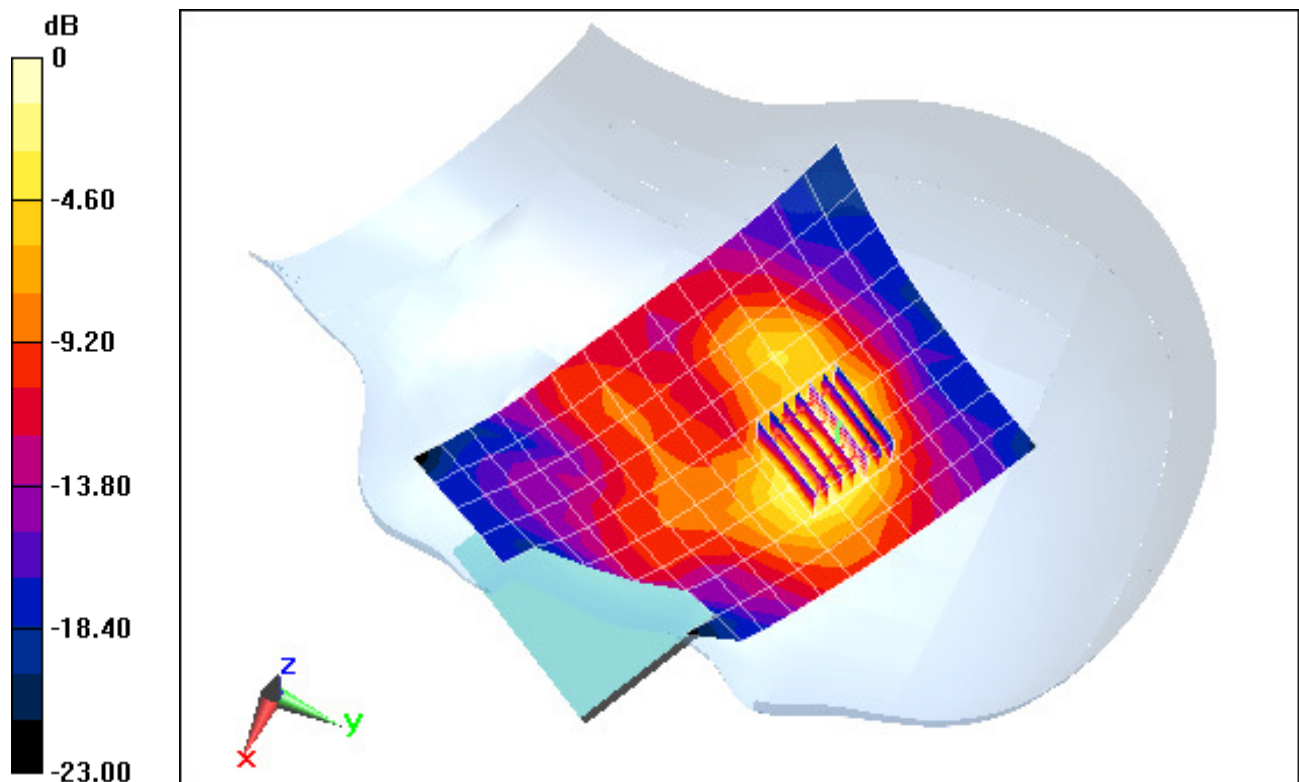

0 dB = 0.080mW/g = -21.94 dB mW/g

PCTEST ENGINEERING LABORATORY, INC.

DUT: A3LSCHI415; Type: Portable Handset; Serial: 0841-1295

Communication System: IEEE 802.11a 5.2-5.8 GHz Band; Frequency: 5700 MHz; Duty Cycle: 1:1
Medium: 5 GHz Head; Medium parameters used:

$f = 5700$ MHz; $\sigma = 5.114$ mho/m; $\epsilon_r = 35.63$; $\rho = 1000$ kg/m³

Phantom section: Right Section

Test Date: 06-19-2012; Ambient Temp: 24.5°C; Tissue Temp: 23.7°C

Probe: EX3DV4 - SN3589; ConvF(4.05, 4.05, 4.05); Calibrated: 1/27/2012

Sensor-Surface: 2mm (Mechanical Surface Detection)

Electronics: DAE4 Sn1323; Calibrated: 2/15/2012

Phantom: SAM Main; Type: SAM 4.0; Serial: TP-1114

Measurement SW: DASY4, Version 4.7 (80); SEMCAD X Version 14.6.4 (4989)

Mode: IEEE 802.11a 5.5 - 5.7 GHz, Right Head, Touch, Ch 140, 6 Mbps

Area Scan (12x17x1): Measurement grid: dx=10mm, dy=10mm

Zoom Scan (7x7x11)/Cube 0: Measurement grid: dx=4mm, dy=4mm, dz=2mm

Reference Value = 0 V/m; Power Drift = 0.00 dB

Peak SAR (extrapolated) = 0.4580 W/kg

SAR(1 g) = 0.033 mW/g; SAR(10 g) = 0.00488 mW/g

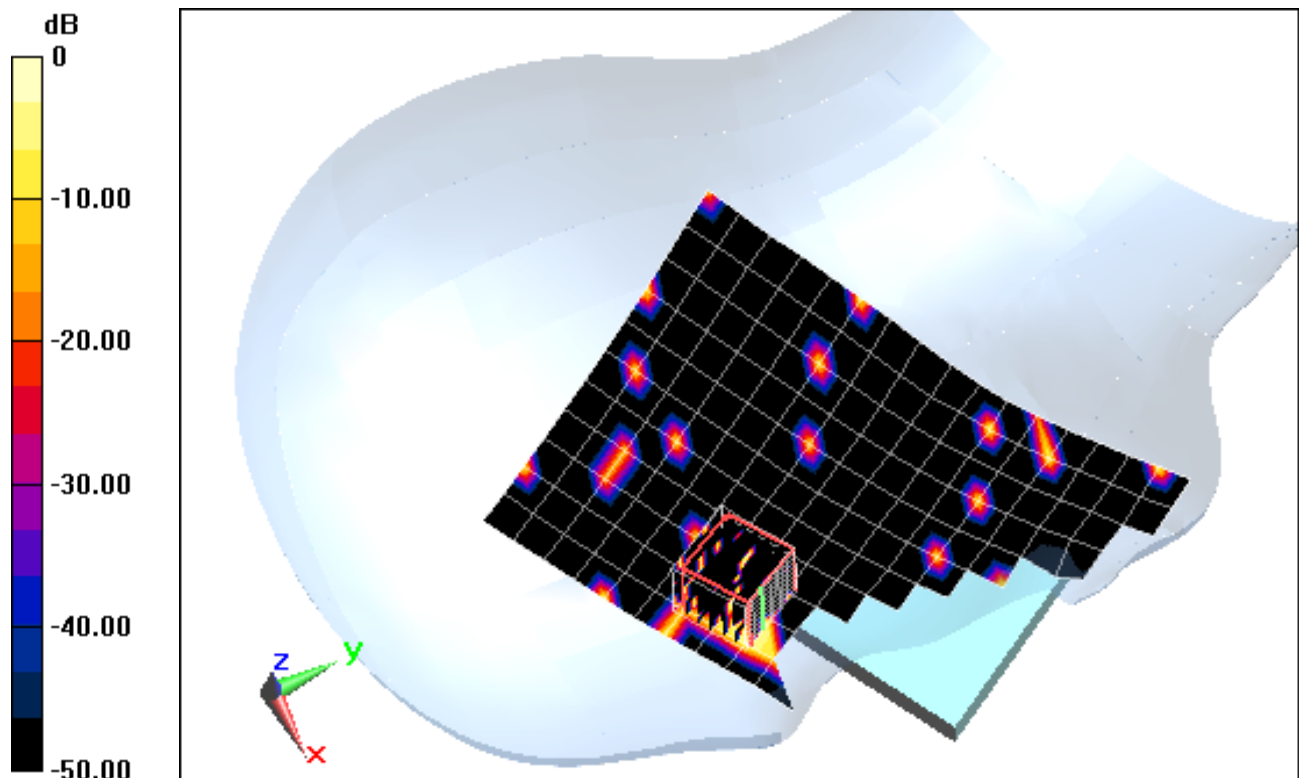

0 dB = 0.060mW/g = -24.44 dB mW/g

PCTEST ENGINEERING LABORATORY, INC.

DUT: A3LSCHI415; Type: Portable Handset; Serial: 0841-1295

Communication System: IEEE 802.11a 5.2-5.8 GHz Band; Frequency: 5785 MHz; Duty Cycle: 1:1
Medium: 5 GHz Head; Medium parameters used:

$f = 5785 \text{ MHz}$; $\sigma = 5.181 \text{ mho/m}$; $\epsilon_r = 35.51$; $\rho = 1000 \text{ kg/m}^3$

Phantom section: Right Section

Test Date: 06-19-2012; Ambient Temp: 24.5°C; Tissue Temp: 23.7°C

Probe: EX3DV4 - SN3589; ConvF(4.05, 4.05, 4.05); Calibrated: 1/27/2012

Sensor-Surface: 2mm (Mechanical Surface Detection)

Electronics: DAE4 Sn1323; Calibrated: 2/15/2012

Phantom: SAM Main; Type: SAM 4.0; Serial: TP-1114

Measurement SW: DASY4, Version 4.7 (80);SEMCAD X Version 14.6.4 (4989)

Mode: IEEE 802.11a 5.8 GHz, Right Head, Tilt, Ch 157, 6 Mbps

Area Scan (12x16x1): Measurement grid: dx=10mm, dy=10mm

Zoom Scan (7x7x11)/Cube 0: Measurement grid: dx=4mm, dy=4mm, dz=2mm

Reference Value = 0.548 V/m; Power Drift = 0.140 dB

Peak SAR (extrapolated) = 0.2000 W/kg

SAR(1 g) = 0.00751 mW/g; SAR(10 g) = 0.000858 mW/g

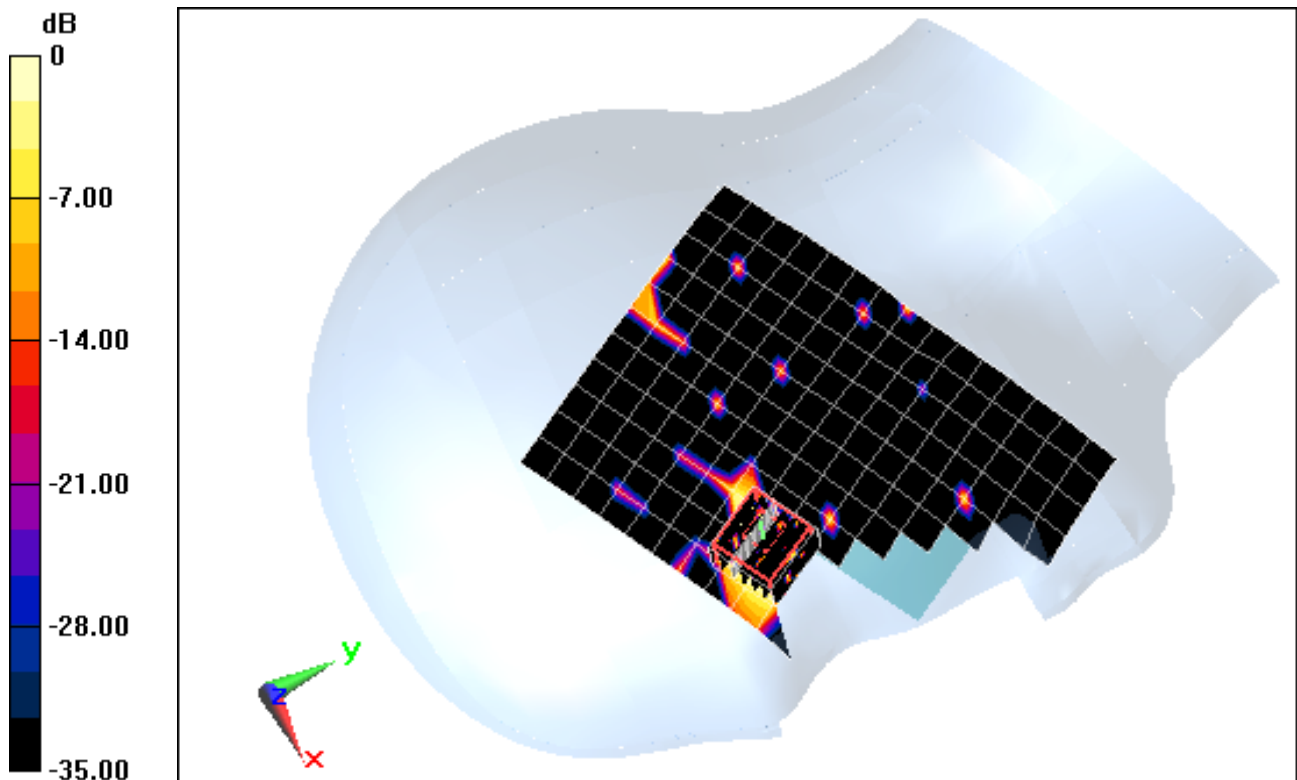

0 dB = 0.060mW/g = -24.44 dB mW/g

PCTEST ENGINEERING LABORATORY, INC.

DUT: A3LSCHI415; Type: Portable Handset; Serial: 0841-1295

Communication System: IEEE 802.11a 5.2-5.8 GHz Band; Frequency: 5785 MHz; Duty Cycle: 1:1
Medium: 5 GHz Head; Medium parameters used:

$f = 5785 \text{ MHz}$; $\sigma = 5.181 \text{ mho/m}$; $\epsilon_r = 35.51$; $\rho = 1000 \text{ kg/m}^3$

Phantom section: Left Section

Test Date: 06-19-2012; Ambient Temp: 24.5°C; Tissue Temp: 23.7°C

Probe: EX3DV4 - SN3589; ConvF(4.05, 4.05, 4.05); Calibrated: 1/27/2012

Sensor-Surface: 2mm (Mechanical Surface Detection)

Electronics: DAE4 Sn1323; Calibrated: 2/15/2012

Phantom: SAM Main; Type: SAM 4.0; Serial: TP-1114

Measurement SW: DASY4, Version 4.7 (80);SEMCAD X Version 14.6.4 (4989)

Mode: IEEE 802.11a, 5.8 GHz Left Head, Touch, Ch 157, 6 Mbps

Area Scan (12x17x1): Measurement grid: dx=10mm, dy=10mm

Zoom Scan (7x7x11)/Cube 0: Measurement grid: dx=4mm, dy=4mm, dz=2mm

Reference Value = 5.059 V/m; Power Drift = 0.023 dB

Peak SAR (extrapolated) = 0.5190 W/kg

SAR(1 g) = 0.082 mW/g; SAR(10 g) = 0.024 mW/g

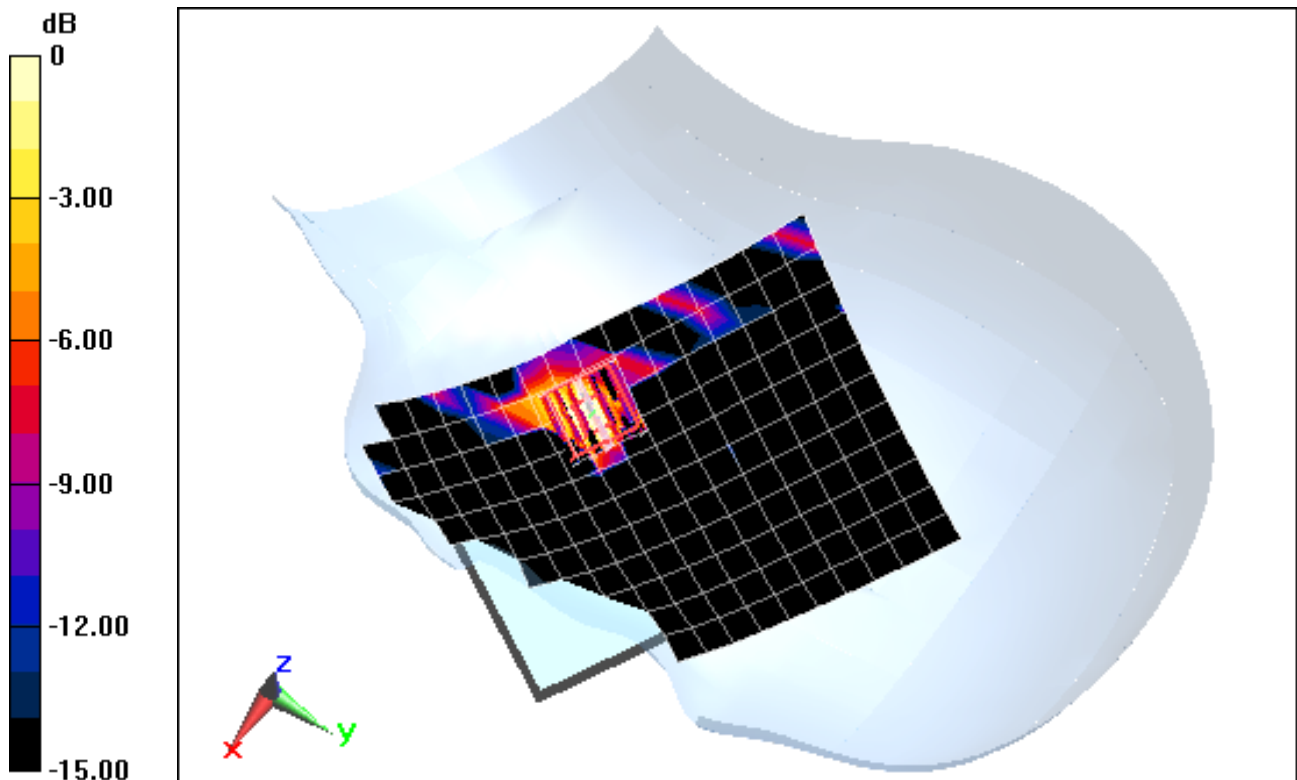

PCTEST ENGINEERING LABORATORY, INC.

DUT: A3LSCHI415; Type: Portable Handset; Serial: 0841-1295

Communication System: IEEE 802.11a 5.2-5.8 GHz Band; Frequency: 5700 MHz; Duty Cycle: 1:1

Medium: 5 GHz Head; Medium parameters used: f

$f = 5700 \text{ MHz}$; $\sigma = 5.114 \text{ mho/m}$; $\epsilon_r = 35.63$; $\rho = 1000 \text{ kg/m}^3$

Phantom section: Left Section

Test Date: 06-19-2012; Ambient Temp: 24.5°C; Tissue Temp: 23.7°C

Probe: EX3DV4 - SN3589; ConvF(4.05, 4.05, 4.05); Calibrated: 1/27/2012

Sensor-Surface: 2mm (Mechanical Surface Detection)

Electronics: DAE4 Sn1323; Calibrated: 2/15/2012

Phantom: SAM Main; Type: SAM 4.0; Serial: TP-1114

Measurement SW: DASY4, Version 4.7 (80); SEMCAD X Version 14.6.4 (4989)

Mode: IEEE 802.11a, 5.5 - 5.7 GHz Left Head, Tilt, Ch 140, 6 Mbps

Area Scan (12x17x1): Measurement grid: dx=10mm, dy=10mm

Zoom Scan (7x7x11)/Cube 0: Measurement grid: dx=4mm, dy=4mm, dz=2mm

Reference Value = 0.896 V/m; Power Drift = 0.16 dB

Peak SAR (extrapolated) = 0.0860 W/kg

SAR(1 g) = 0.00235 mW/g; SAR(10 g) = 0.000281 mW/g

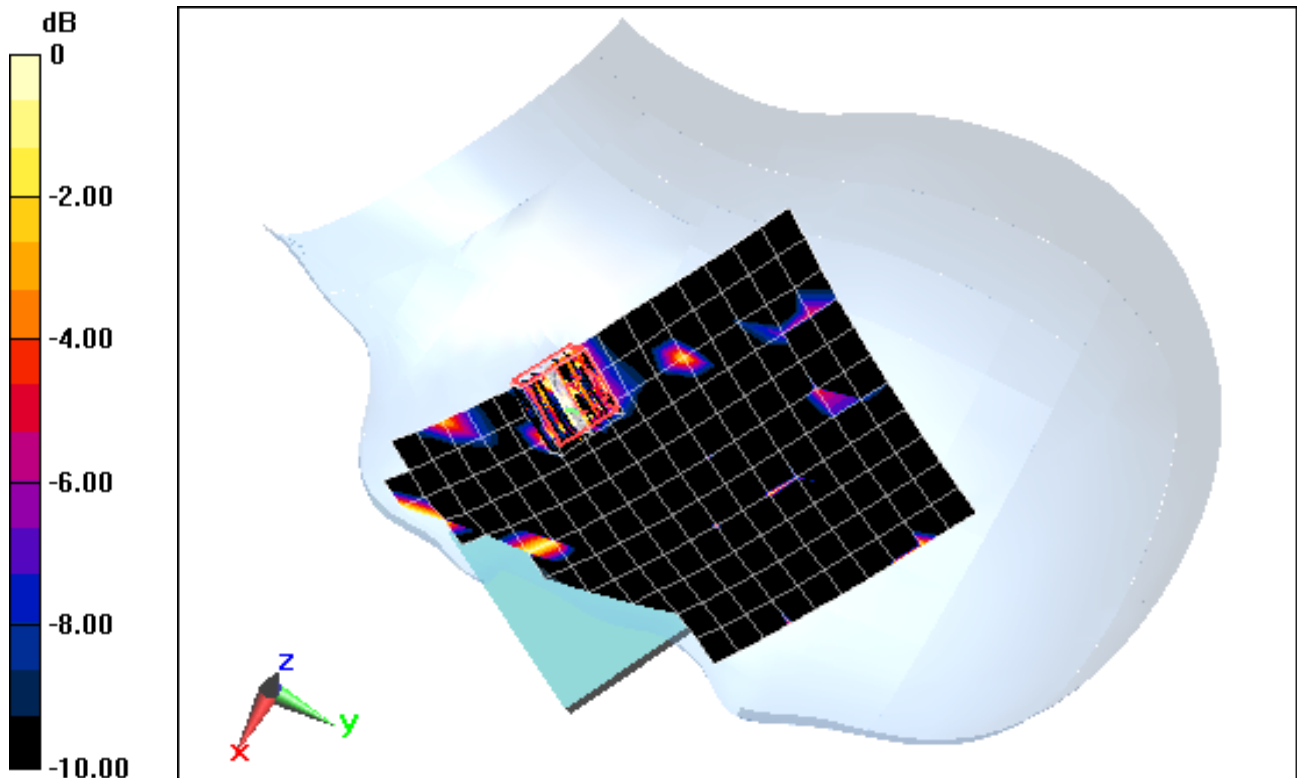

0 dB = 0.040mW/g = -27.96 dB mW/g

PCTEST ENGINEERING LABORATORY, INC.

DUT: A3LSCHI415; Type: Portable Handset; Serial: 0841-1298

Communication System: LTE Band 13; Frequency: 782 MHz; Duty Cycle: 1:1

Medium: 770 Body; Medium parameters used (interpolated):

$f = 782 \text{ MHz}$; $\sigma = 1.003 \text{ mho/m}$; $\epsilon_r = 54.08$; $\rho = 1000 \text{ kg/m}^3$

Phantom section: Flat Section; Space: 1.0 cm

Test Date: 06-11-2012; Ambient Temp: 22.4°C; Tissue Temp: 21.9°C

Probe: EX3DV4 - SN3561; ConvF(8.34, 8.34, 8.34); Calibrated: 7/27/2011

Sensor-Surface: 4mm (Mechanical Surface Detection)

Electronics: DAE4 Sn1333; Calibrated: 4/12/2012

Phantom: SAM 5.0 front; Type: QD000P40CD; Serial: TP:-1648

Measurement SW: DASY52, Version 52.8 (0);SEMCAD X Version 14.6.4 (4989)

**Mode: LTE Band 13, Body SAR, Back side, Mid.ch,
QPSK, 10 MHz Bandwidth, 1 RB, RB Offset 49**

Area Scan (7x11x1): Measurement grid: dx=15mm, dy=15mm

Zoom Scan (5x5x7)/Cube 0: Measurement grid: dx=8mm, dy=8mm, dz=5mm

Reference Value = 15.662 V/m; Power Drift = 0.03 dB

Peak SAR (extrapolated) = 0.3970 W/kg

SAR(1 g) = 0.228 mW/g; SAR(10 g) = 0.139 mW/g

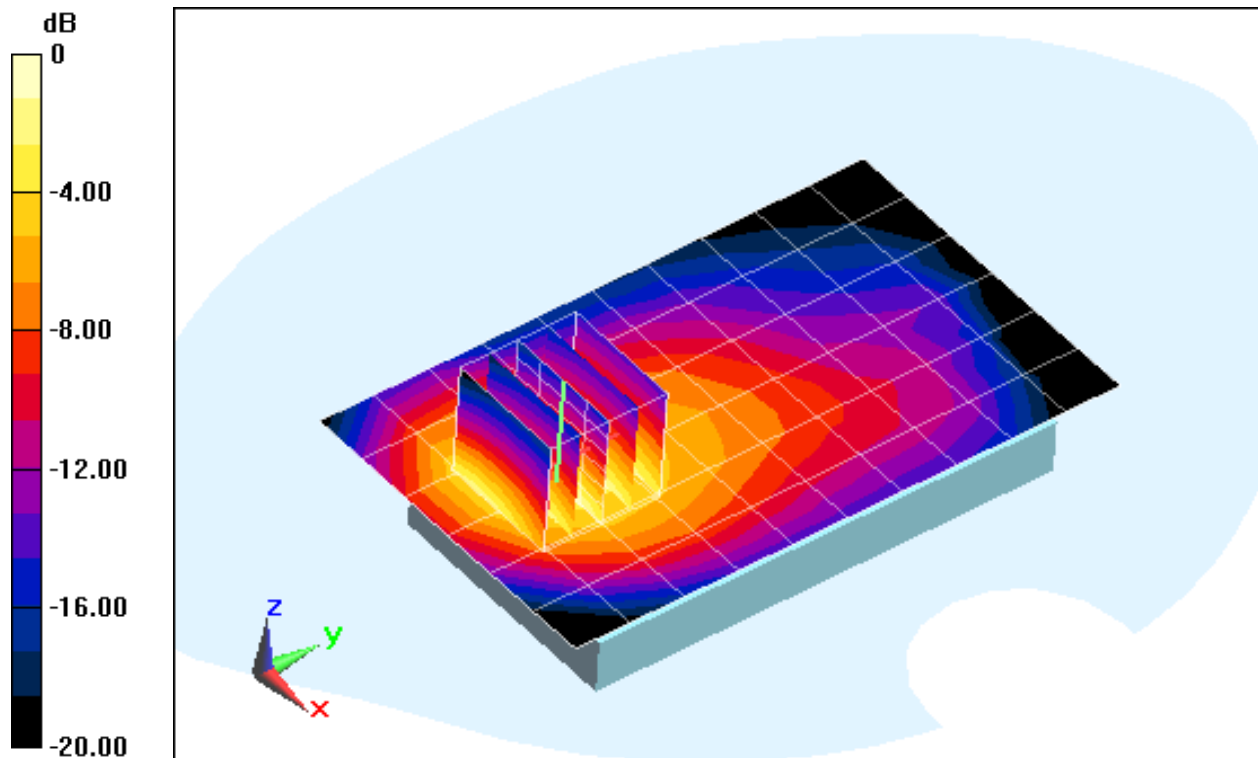

0 dB = 0.240mW/g = -12.40 dB mW/g

PCTEST ENGINEERING LABORATORY, INC.

DUT: A3LSCHI415; Type: Portable Handset; Serial: 0841-1298

Communication System: LTE Band 13; Frequency: 782 MHz; Duty Cycle: 1:1
Medium: 770 Body; Medium parameters used (interpolated):
 $f = 782 \text{ MHz}$; $\sigma = 1.003 \text{ mho/m}$; $\epsilon_r = 54.08$; $\rho = 1000 \text{ kg/m}^3$
Phantom section: Flat Section; Space: 1.0 cm

Test Date: 06-11-2012; Ambient Temp: 22.4°C; Tissue Temp: 21.9°C

Probe: EX3DV4 - SN3561; ConvF(8.34, 8.34, 8.34); Calibrated: 7/27/2011
Sensor-Surface: 4mm (Mechanical Surface Detection)
Electronics: DAE4 Sn1333; Calibrated: 4/12/2012
Phantom: SAM 5.0 front; Type: QD000P40CD; Serial: TP:-1648
Measurement SW: DASY52, Version 52.8 (0);SEMCAD X Version 14.6.4 (4989)

**Mode/LTE Band 13, Body SAR, Front side, Mid.ch,
QPSK, 10 MHz Bandwidth, 1 RB, RB Offset 49**

Area Scan (7x11x1): Measurement grid: dx=15mm, dy=15mm
Zoom Scan (5x5x7)/Cube 0: Measurement grid: dx=8mm, dy=8mm, dz=5mm
Reference Value = 7.846 V/m; Power Drift = -0.01 dB
Peak SAR (extrapolated) = 0.0910 W/kg
SAR(1 g) = 0.060 mW/g; SAR(10 g) = 0.039 mW/g

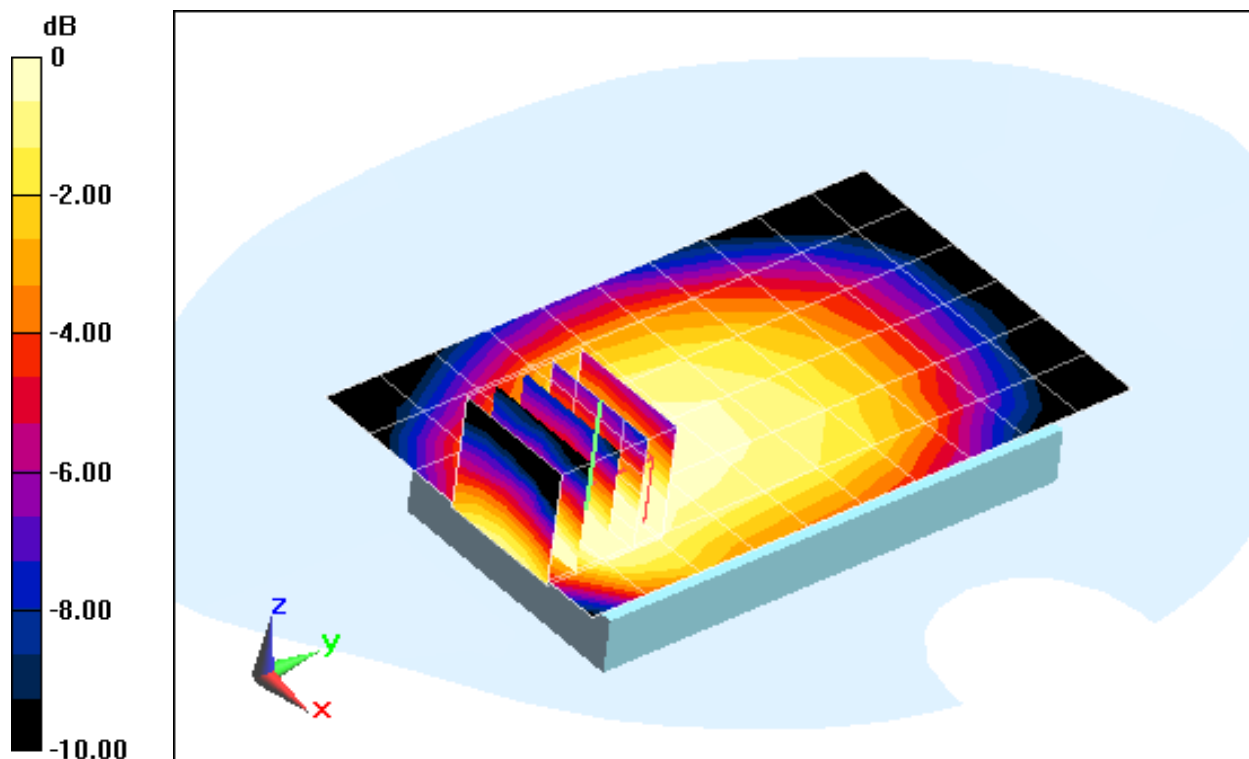

0 dB = 0.030mW/g = -30.46 dB mW/g

PCTEST ENGINEERING LABORATORY, INC.

DUT: A3LSCHI415; Type: Portable Handset; Serial: 0841-1298

Communication System: LTE Band 13; Frequency: 782 MHz; Duty Cycle: 1:1

Medium: 770 Body; Medium parameters used (interpolated):

$f = 782 \text{ MHz}$; $\sigma = 1.003 \text{ mho/m}$; $\epsilon_r = 54.08$; $\rho = 1000 \text{ kg/m}^3$

Phantom section: Flat Section; Space: 1.0 cm

Test Date: 06-11-2012; Ambient Temp: 22.4°C; Tissue Temp: 21.9°C

Probe: EX3DV4 - SN3561; ConvF(8.34, 8.34, 8.34); Calibrated: 7/27/2011

Sensor-Surface: 4mm (Mechanical Surface Detection)

Electronics: DAE4 Sn1333; Calibrated: 4/12/2012

Phantom: SAM 5.0 front; Type: QD000P40CD; Serial: TP:-1648

Measurement SW: DASY52, Version 52.8 (0);SEMCAD X Version 14.6.4 (4989)

**Mode: LTE Band 13, Body SAR, Bottom Edge, Mid.ch,
QPSK, 10 MHz Bandwidth, 1 RB, RB Offset 49**

Area Scan (5x7x1): Measurement grid: dx=15mm, dy=15mm

Zoom Scan (5x5x7)/Cube 0: Measurement grid: dx=8mm, dy=8mm, dz=5mm

Reference Value = 10.376 V/m; Power Drift = 0.06 dB

Peak SAR (extrapolated) = 0.1600 W/kg

SAR(1 g) = 0.102 mW/g; SAR(10 g) = 0.063 mW/g

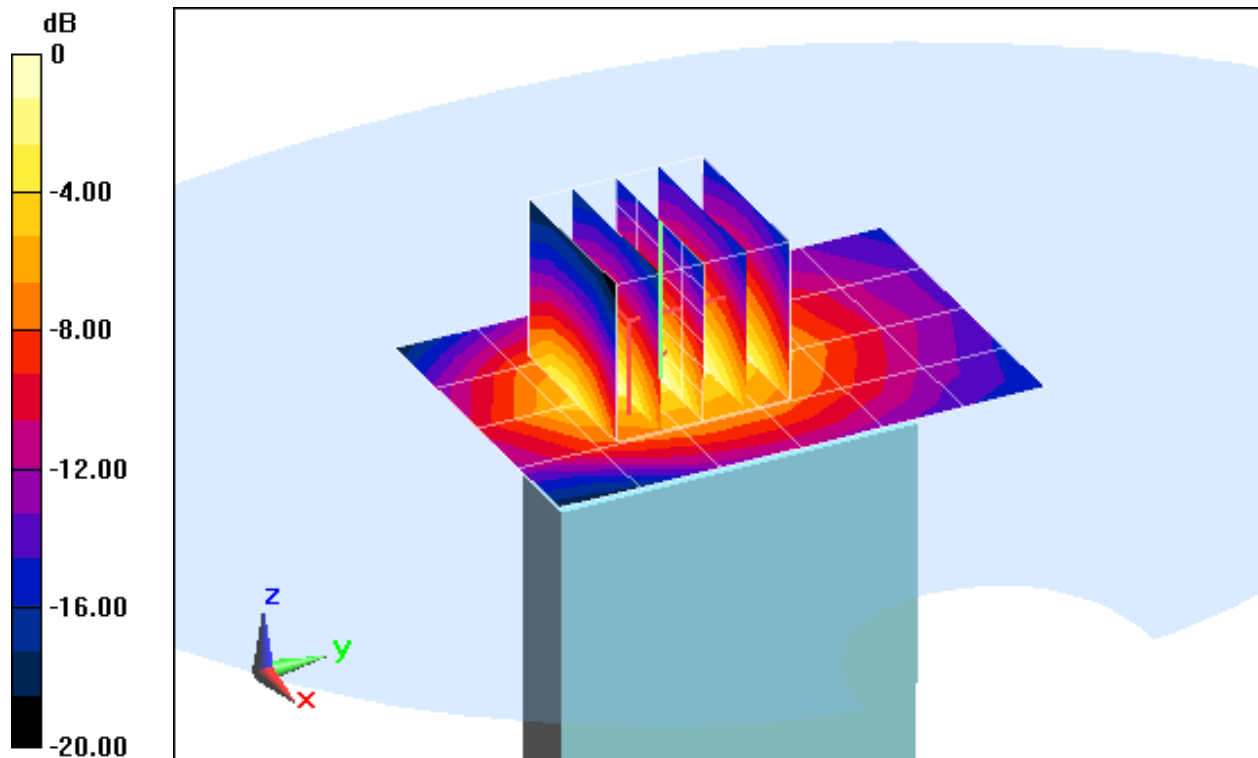

0 dB = 0.110mW/g = -19.17 dB mW/g

PCTEST ENGINEERING LABORATORY, INC.

DUT: A3LSCHI415; Type: Portable Handset; Serial: 0841-1298

Communication System: LTE Band 13; Frequency: 782 MHz; Duty Cycle: 1:1

Medium: 770 Body; Medium parameters used (interpolated):

$f = 782 \text{ MHz}$; $\sigma = 1.003 \text{ mho/m}$; $\epsilon_r = 54.08$; $\rho = 1000 \text{ kg/m}^3$

Phantom section: Flat Section; Space: 1.0 cm

Test Date: 06-11-2012; Ambient Temp: 22.4°C; Tissue Temp: 21.9°C

Probe: EX3DV4 - SN3561; ConvF(8.34, 8.34, 8.34); Calibrated: 7/27/2011

Sensor-Surface: 4mm (Mechanical Surface Detection)

Electronics: DAE4 Sn1333; Calibrated: 4/12/2012

Phantom: SAM 5.0 front; Type: QD000P40CD; Serial: TP:-1648

Measurement SW: DASY52, Version 52.8 (0);SEMCAD X Version 14.6.4 (4989)

**Mode: LTE Band 13, Body SAR, Right Edge, Mid.ch,
QPSK, 10 MHz Bandwidth, 1 RB, RB Offset 0**

Area Scan (5x13x1): Measurement grid: dx=15mm, dy=15mm

Zoom Scan (5x5x7)/Cube 0: Measurement grid: dx=8mm, dy=8mm, dz=5mm

Reference Value = 11.795 V/m; Power Drift = 0.02 dB

Peak SAR (extrapolated) = 0.1880 W/kg

SAR(1 g) = 0.131 mW/g; SAR(10 g) = 0.090 mW/g

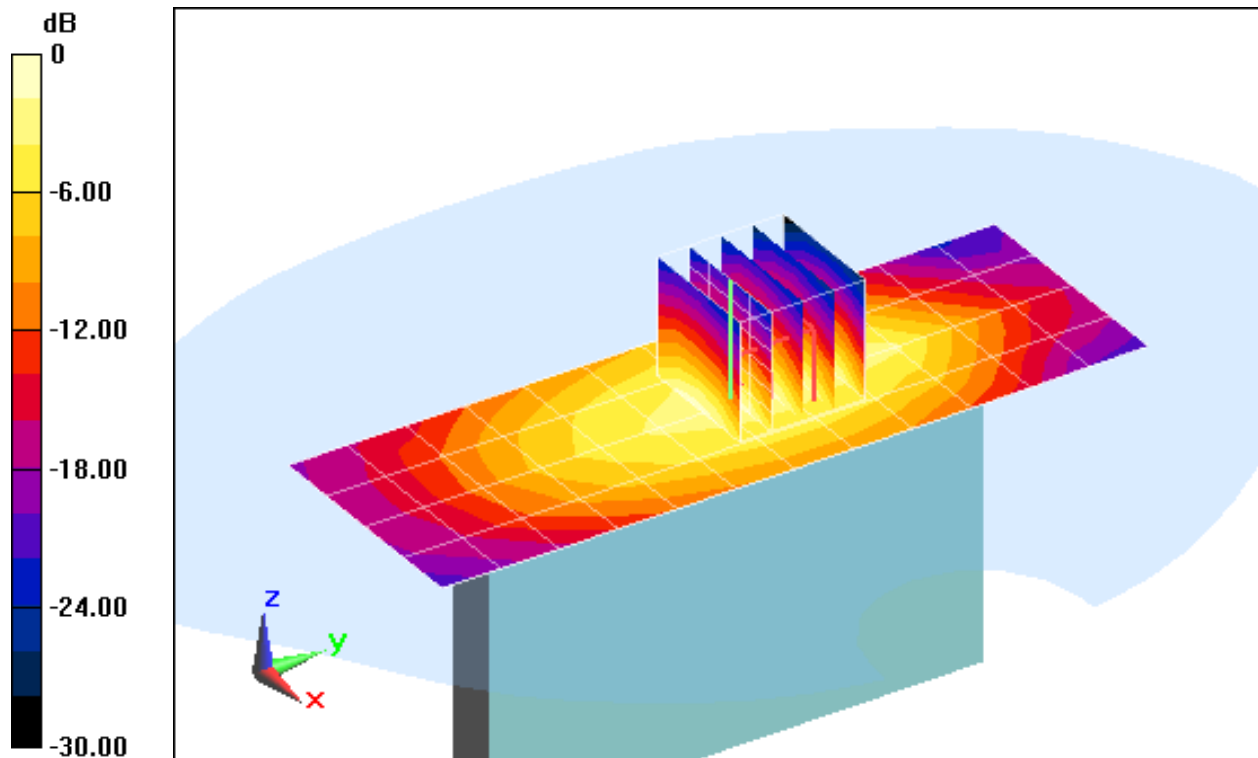

0 dB = 0.140mW/g = -17.08 dB mW/g

PCTEST ENGINEERING LABORATORY, INC.

DUT: A3LSCHI415; Type: Portable Handset; Serial: 0841-1297

Communication System: Cellular CDMA; Frequency: 836.52 MHz; Duty Cycle: 1:1

Medium: 835 Body; Medium parameters used (interpolated):

$f = 836.52$ MHz; $\sigma = 0.999$ mho/m; $\epsilon_r = 53.644$; $\rho = 1000$ kg/m³

Phantom section: Flat Section; Space: 1.0 cm

Test Date: 05-31-2012; Ambient Temp: 23.6°C; Tissue Temp: 22.5°C

Probe: ES3DV3 - SN3258; ConvF(6.06, 6.06, 6.06); Calibrated: 2/21/2012

Sensor-Surface: 4mm (Mechanical Surface Detection)

Electronics: DAE4 Sn1272; Calibrated: 1/18/2012

Phantom: SAM Main; Type: SAM 4.0; Serial: TP-1406

Measurement SW: DASY4, Version 4.7 (80);SEMCAD X Version 14.6.4 (4989)

Mode: Cellular EVDO, Body SAR, Back side, Mid.ch

Area Scan (7x12x1): Measurement grid: dx=15mm, dy=15mm

Zoom Scan (5x5x7)/Cube 0: Measurement grid: dx=8mm, dy=8mm, dz=5mm

Reference Value = 29.042 V/m; Power Drift = -0.06 dB

Peak SAR (extrapolated) = 1.0490 W/kg

SAR(1 g) = 0.693 mW/g; SAR(10 g) = 0.464 mW/g

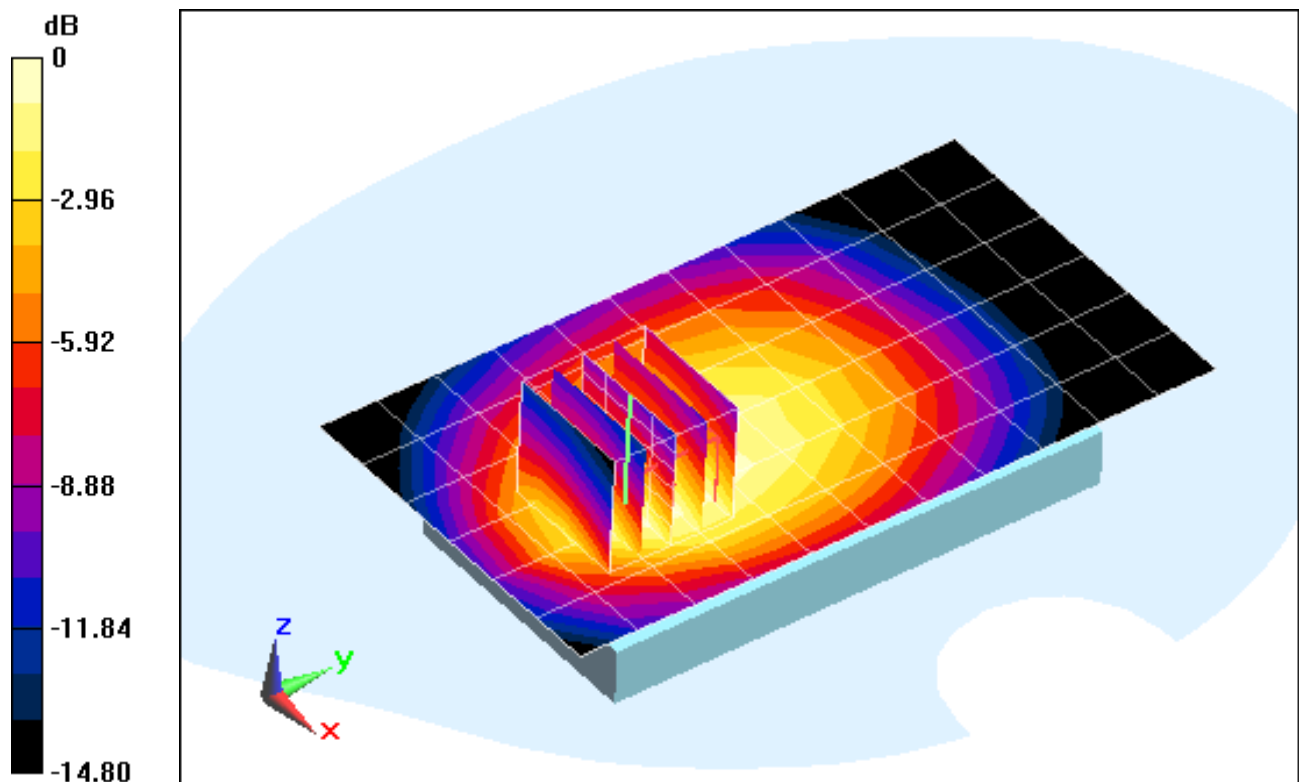

0 dB = 0.740mW/g = -2.62 dB mW/g

PCTEST ENGINEERING LABORATORY, INC.

DUT: A3LSCHI415; Type: Portable Handset; Serial: 0841-1297

Communication System: Cellular CDMA; Frequency: 836.52 MHz; Duty Cycle: 1:1

Medium: 835 Body; Medium parameters used (interpolated):

$f = 836.52$ MHz; $\sigma = 0.999$ mho/m; $\epsilon_r = 53.644$; $\rho = 1000$ kg/m³

Phantom section: Flat Section; Space: 1.0 cm

Test Date: 05-31-2012; Ambient Temp: 23.6°C; Tissue Temp: 22.5°C

Probe: ES3DV3 - SN3258; ConvF(6.06, 6.06, 6.06); Calibrated: 2/21/2012

Sensor-Surface: 4mm (Mechanical Surface Detection)

Electronics: DAE4 Sn1272; Calibrated: 1/18/2012

Phantom: SAM Main; Type: SAM 4.0; Serial: TP-1406

Measurement SW: DASY4, Version 4.7 (80);SEMCAD X Version 14.6.4 (4989)

Mode: Cellular CDMA, Body SAR, Front side, Mid.ch

Area Scan (7x12x1): Measurement grid: dx=15mm, dy=15mm

Zoom Scan (5x5x7)/Cube 0: Measurement grid: dx=8mm, dy=8mm, dz=5mm

Reference Value = 18.795 V/m; Power Drift = -0.03 dB

Peak SAR (extrapolated) = 0.3860 W/kg

SAR(1 g) = 0.307 mW/g; SAR(10 g) = 0.232 mW/g

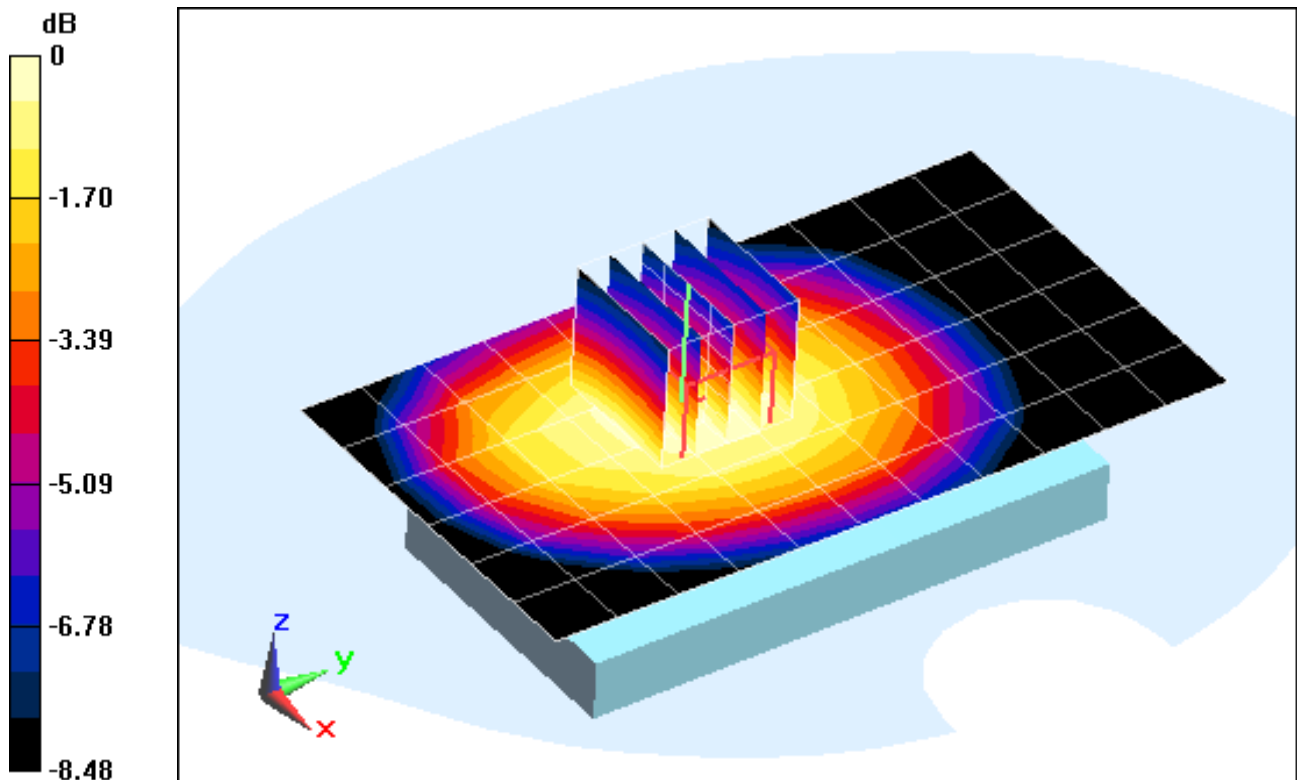

0 dB = 0.320mW/g = -9.90 dB mW/g

PCTEST ENGINEERING LABORATORY, INC.

DUT: A3LSCHI415; Type: Portable Handset; Serial: 0841-1297

Communication System: Cellular CDMA; Frequency: 836.52 MHz; Duty Cycle: 1:1

Medium: 835 Body; Medium parameters used (interpolated):

$f = 836.52$ MHz; $\sigma = 0.999$ mho/m; $\epsilon_r = 53.644$; $\rho = 1000$ kg/m³

Phantom section: Flat Section; Space: 1.0 cm

Test Date: 05-31-2012; Ambient Temp: 23.6°C; Tissue Temp: 22.5°C

Probe: ES3DV3 - SN3258; ConvF(6.06, 6.06, 6.06); Calibrated: 2/21/2012

Sensor-Surface: 4mm (Mechanical Surface Detection)

Electronics: DAE4 Sn1272; Calibrated: 1/18/2012

Phantom: SAM Main; Type: SAM 4.0; Serial: TP-1406

Measurement SW: DASY4, Version 4.7 (80); SEMCAD X Version 14.6.4 (4989)

Mode: Cellular CDMA, Body SAR, Bottom Edge, Mid.ch

Area Scan (5x7x1): Measurement grid: dx=15mm, dy=15mm

Zoom Scan (5x5x7)/Cube 0: Measurement grid: dx=8mm, dy=8mm, dz=5mm

Reference Value = 13.659 V/m; Power Drift = 0.17 dB

Peak SAR (extrapolated) = 0.2650 W/kg

SAR(1 g) = 0.153 mW/g; SAR(10 g) = 0.090 mW/g

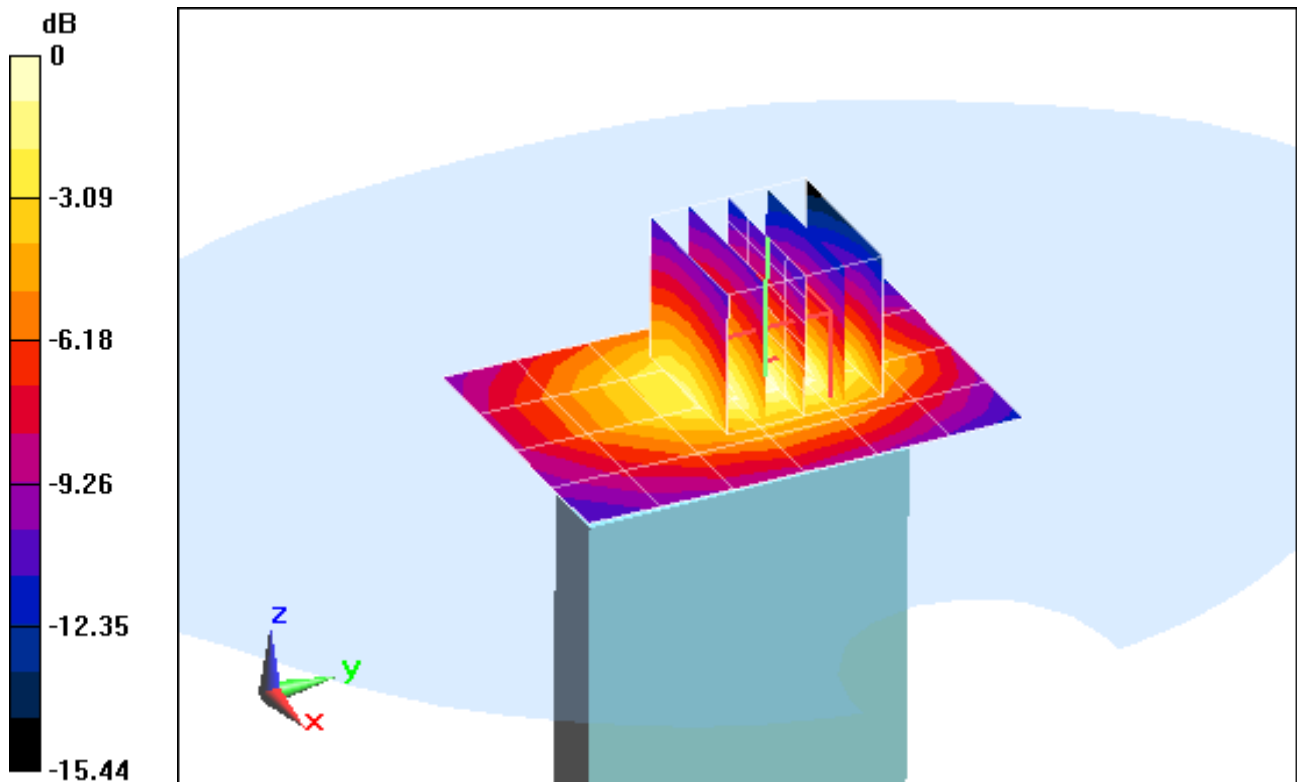

0 dB = 0.170mW/g = -15.39 dB mW/g

PCTEST ENGINEERING LABORATORY, INC.

DUT: A3LSCHI415; Type: Portable Handset; Serial: 0841-1297

Communication System: Cellular CDMA; Frequency: 836.52 MHz; Duty Cycle: 1:1

Medium: 835 Body; Medium parameters used (interpolated):

$f = 836.52$ MHz; $\sigma = 0.999$ mho/m; $\epsilon_r = 53.644$; $\rho = 1000$ kg/m³

Phantom section: Flat Section; Space: 1.0 cm

Test Date: 05-31-2012; Ambient Temp: 23.6°C; Tissue Temp: 22.5°C

Probe: ES3DV3 - SN3258; ConvF(6.06, 6.06, 6.06); Calibrated: 2/21/2012

Sensor-Surface: 4mm (Mechanical Surface Detection)

Electronics: DAE4 Sn1272; Calibrated: 1/18/2012

Phantom: SAM Main; Type: SAM 4.0; Serial: TP-1406

Measurement SW: DASY4, Version 4.7 (80);SEMCAD X Version 14.6.4 (4989)

Mode: Cellular CDMA, Body SAR, Left Edge, Mid.ch

Area Scan (5x13x1): Measurement grid: dx=15mm, dy=15mm

Zoom Scan (5x5x7)/Cube 0: Measurement grid: dx=8mm, dy=8mm, dz=5mm

Reference Value = 25.220 V/m; Power Drift = 0.05 dB

Peak SAR (extrapolated) = 0.7250 W/kg

SAR(1 g) = 0.526 mW/g; SAR(10 g) = 0.366 mW/g

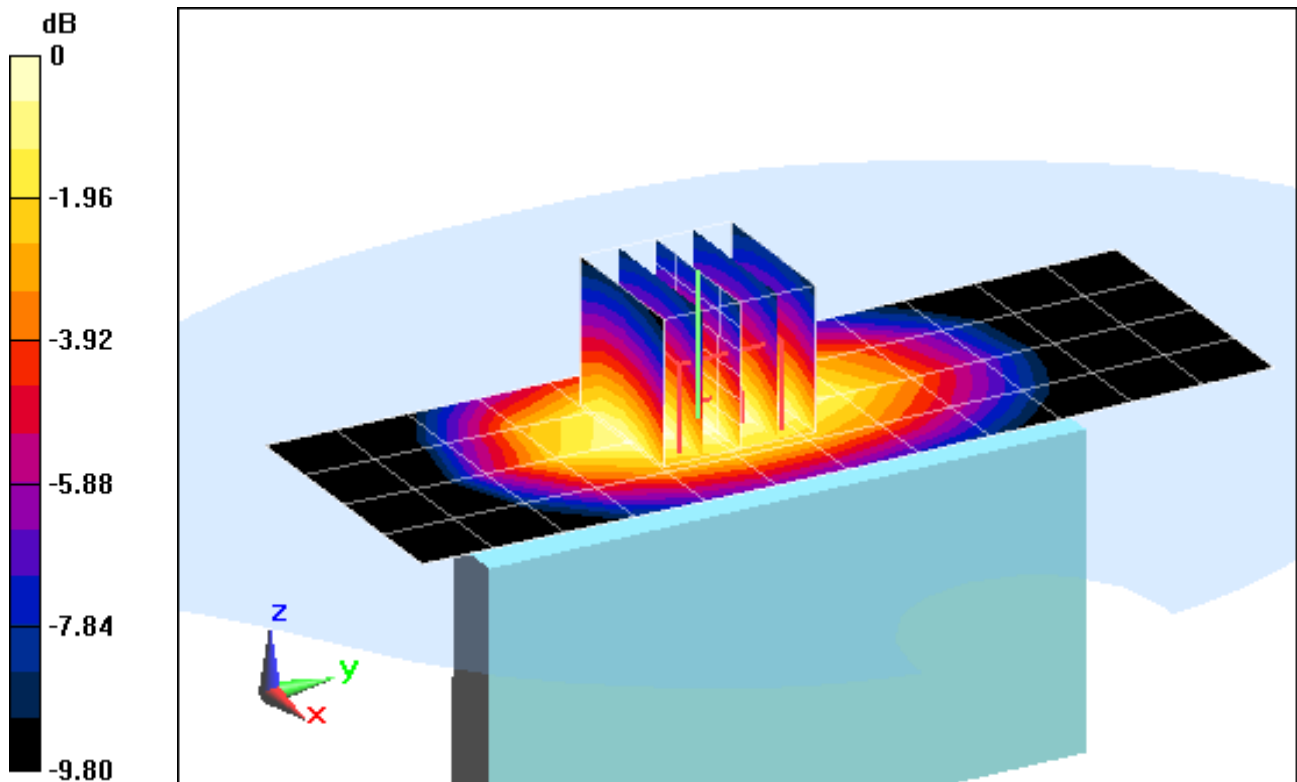

0 dB = 0.560mW/g = -5.04 dB mW/g

PCTEST ENGINEERING LABORATORY, INC.

DUT: A3LSCHI415; Type: Portable Handset; Serial: 0841-1295

Communication System: GSM850 GPRS; 2 Tx slots; Frequency: 836.6 MHz; Duty Cycle: 1:4.15

Medium: 835 Body; Medium parameters used (interpolated):

$f = 836.6$ MHz; $\sigma = 0.997$ mho/m; $\epsilon_r = 54.73$; $\rho = 1000$ kg/m³

Phantom section: Flat Section; Space: 1.0 cm

Test Date: 06-18-2012; Ambient Temp: 24.1°C; Tissue Temp: 23.0°C

Probe: ES3DV3 - SN3209; ConvF(6.13, 6.13, 6.13); Calibrated: 3/16/2012

Sensor-Surface: 4mm (Mechanical Surface Detection)

Electronics: DAE4 Sn1323; Calibrated: 2/15/2012

Phantom: SAM Sub; Type: SAM 4.0; Serial: TP-1357

Measurement SW: DASY4, Version 4.7 (80);SEMCAD X Version 14.6.4 (4989)

Mode: GPRS 850, Body SAR, Back side, Mid.ch, 2 Tx Slots

Area Scan (8x12x1): Measurement grid: dx=15mm, dy=15mm

Zoom Scan (5x5x7)/Cube 0: Measurement grid: dx=8mm, dy=8mm, dz=5mm

Reference Value = 29.070 V/m; Power Drift = -0.12 dB

Peak SAR (extrapolated) = 1.1450 W/kg

SAR(1 g) = 0.762 mW/g; SAR(10 g) = 0.528 mW/g

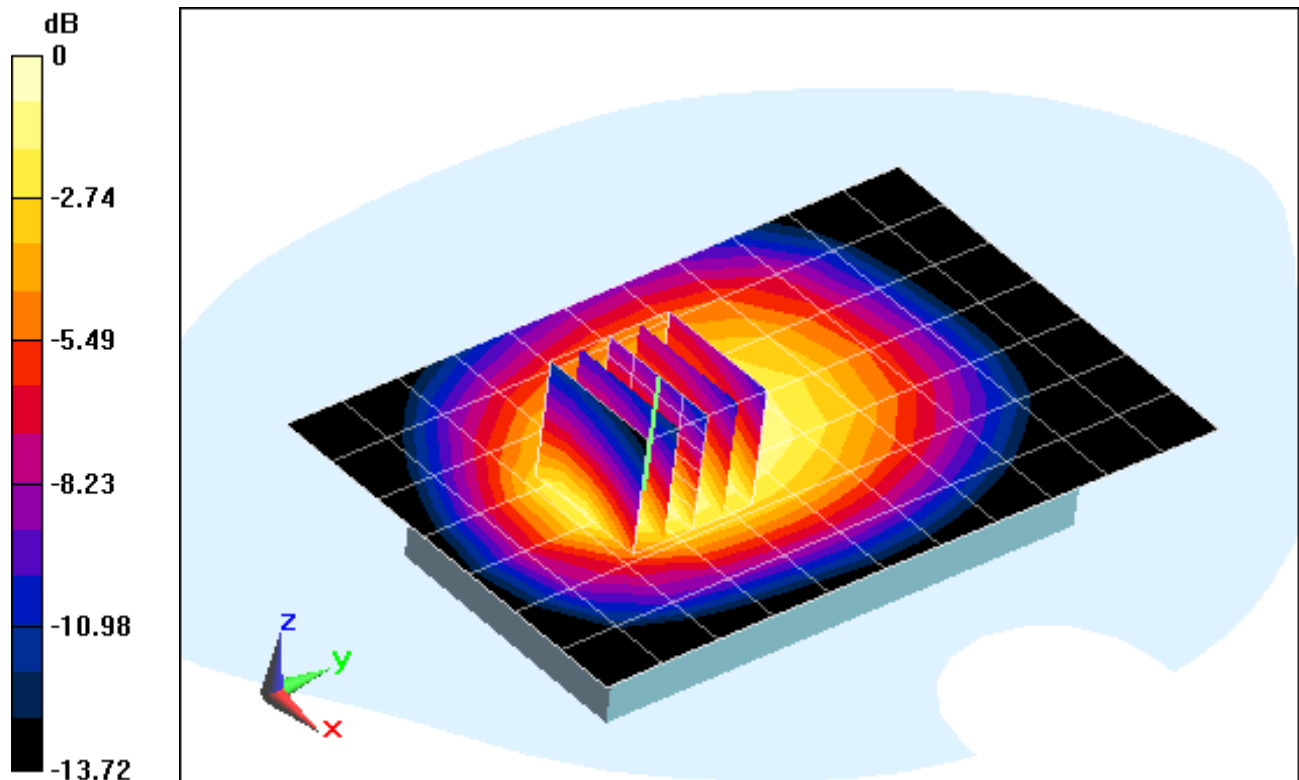

0 dB = 0.810mW/g = -1.83 dB mW/g

PCTEST ENGINEERING LABORATORY, INC.

DUT: A3LSCHI415; Type: Portable Handset; Serial: 0841-1295

Communication System: GSM 850 GPRS; 2 Tx slots; Frequency: 836.6 MHz; Duty Cycle: 1:4.15

Medium: 835 Body; Medium parameters used (interpolated):

$f = 836.6$ MHz; $\sigma = 0.997$ mho/m; $\epsilon_r = 54.73$; $\rho = 1000$ kg/m³

Phantom section: Flat Section; Space: 1.0 cm

Test Date: 06-18-2012; Ambient Temp: 24.1°C; Tissue Temp: 23.0°C

Probe: ES3DV3 - SN3209; ConvF(6.13, 6.13, 6.13); Calibrated: 3/16/2012

Sensor-Surface: 4mm (Mechanical Surface Detection)

Electronics: DAE4 Sn1323; Calibrated: 2/15/2012

Phantom: SAM Sub; Type: SAM 4.0; Serial: TP-1357

Measurement SW: DASY4, Version 4.7 (80);SEMCAD X Version 14.6.4 (4989)

Mode: GPRS 850, Body SAR, Front side, Mid.ch, 2 Tx Slots

Area Scan (8x12x1): Measurement grid: dx=15mm, dy=15mm

Zoom Scan (5x5x7)/Cube 0: Measurement grid: dx=8mm, dy=8mm, dz=5mm

Reference Value = 19.842 V/m; Power Drift = -0.09 dB

Peak SAR (extrapolated) = 0.4540 W/kg

SAR(1 g) = 0.368 mW/g; SAR(10 g) = 0.280 mW/g

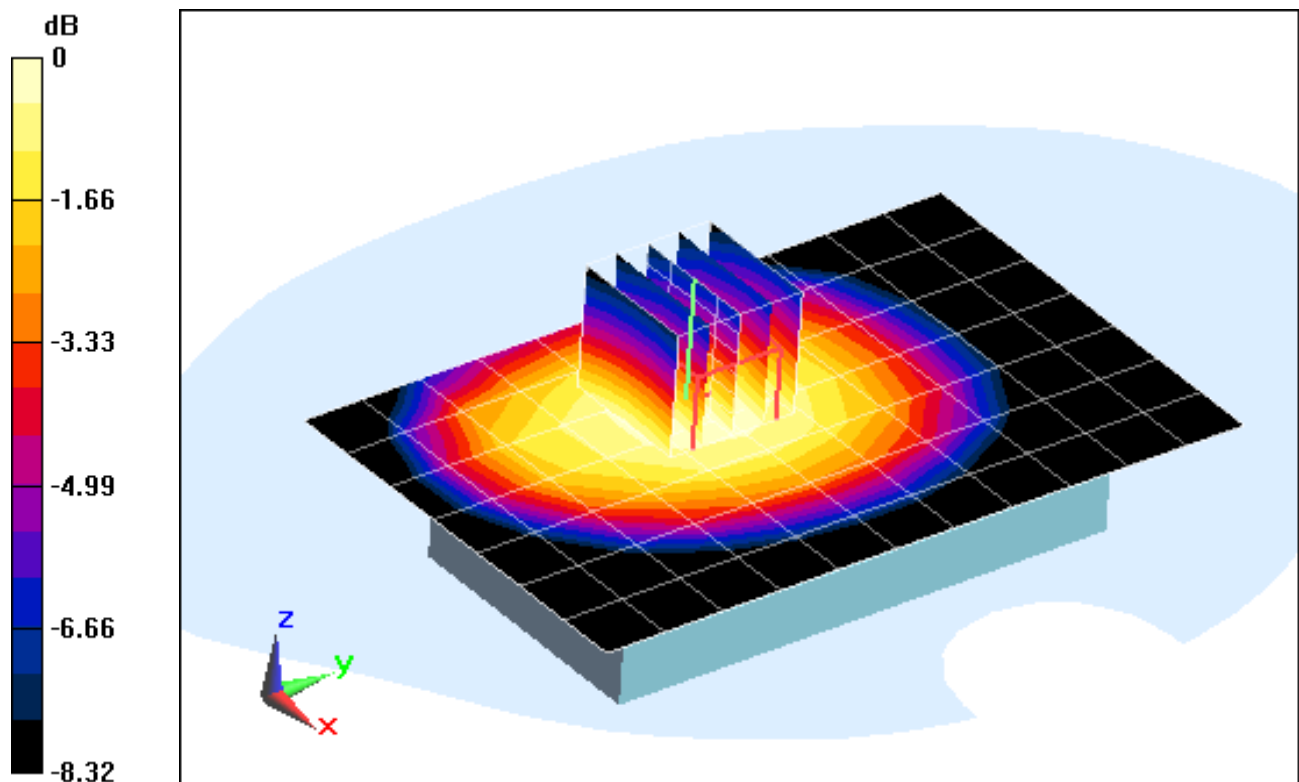

0 dB = 0.390mW/g = -8.18 dB mW/g

PCTEST ENGINEERING LABORATORY, INC.

DUT: A3LSCHI415; Type: Portable Handset; Serial: 0841-1295

Communication System: GSM 850 GPRS; 2 Tx slots; Frequency: 836.6 MHz; Duty Cycle: 1:4.15

Medium: 835 Body; Medium parameters used (interpolated):

$f = 836.6$ MHz; $\sigma = 0.997$ mho/m; $\epsilon_r = 54.73$; $\rho = 1000$ kg/m³

Phantom section: Flat Section; Space: 1.0 cm

Test Date: 06-18-2012; Ambient Temp: 24.1°C; Tissue Temp: 23.0°C

Probe: ES3DV3 - SN3209; ConvF(6.13, 6.13, 6.13); Calibrated: 3/16/2012

Sensor-Surface: 4mm (Mechanical Surface Detection)

Electronics: DAE4 Sn1323; Calibrated: 2/15/2012

Phantom: SAM Sub; Type: SAM 4.0; Serial: TP-1357

Measurement SW: DASY4, Version 4.7 (80); SEMCAD X Version 14.6.4 (4989)

Mode: GPRS 850, Body SAR, Bottom Edge, Mid.ch, 2 Tx Slots

Area Scan (5x7x1): Measurement grid: dx=15mm, dy=15mm

Zoom Scan (5x5x7)/Cube 0: Measurement grid: dx=8mm, dy=8mm, dz=5mm

Reference Value = 12.887 V/m; Power Drift = 0.18 dB

Peak SAR (extrapolated) = 0.2620 W/kg

SAR(1 g) = 0.148 mW/g; SAR(10 g) = 0.085 mW/g

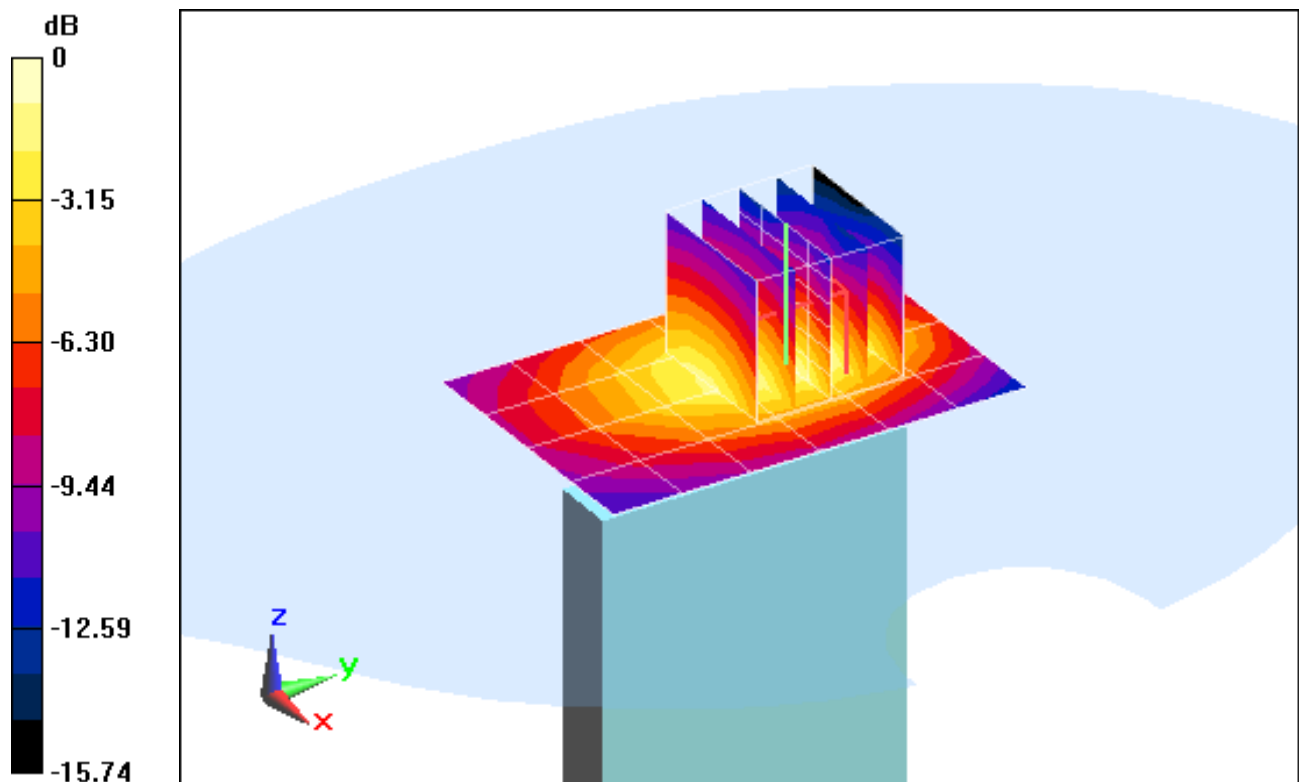

0 dB = 0.160mW/g = -15.92 dB mW/g

PCTEST ENGINEERING LABORATORY, INC.

DUT: A3LSCHI415; Type: Portable Handset; Serial: 0841-1295

Communication System: GSM 850 GPRS; 2 Tx slots; Frequency: 836.6 MHz; Duty Cycle: 1:4.15

Medium: 835 Body; Medium parameters used (interpolated):

$f = 836.6 \text{ MHz}$; $\sigma = 0.997 \text{ mho/m}$; $\epsilon_r = 54.73$; $\rho = 1000 \text{ kg/m}^3$

Phantom section: Flat Section; Space: 1.0 cm

Test Date: 06-18-2012; Ambient Temp: 24.1°C; Tissue Temp: 23.0°C

Probe: ES3DV3 - SN3209; ConvF(6.13, 6.13, 6.13); Calibrated: 3/16/2012

Sensor-Surface: 4mm (Mechanical Surface Detection)

Electronics: DAE4 Sn1323; Calibrated: 2/15/2012

Phantom: SAM Sub; Type: SAM 4.0; Serial: TP-1357

Measurement SW: DASY4, Version 4.7 (80);SEMCAD X Version 14.6.4 (4989)

Mode: GPRS 850, Body SAR, Left Edge, Mid.ch, 2 Tx Slots

Area Scan (5x13x1): Measurement grid: dx=15mm, dy=15mm

Zoom Scan (5x5x7)/Cube 0: Measurement grid: dx=8mm, dy=8mm, dz=5mm

Reference Value = 22.494 V/m; Power Drift = -0.05 dB

Peak SAR (extrapolated) = 0.6920 W/kg

SAR(1 g) = 0.507 mW/g; SAR(10 g) = 0.353 mW/g

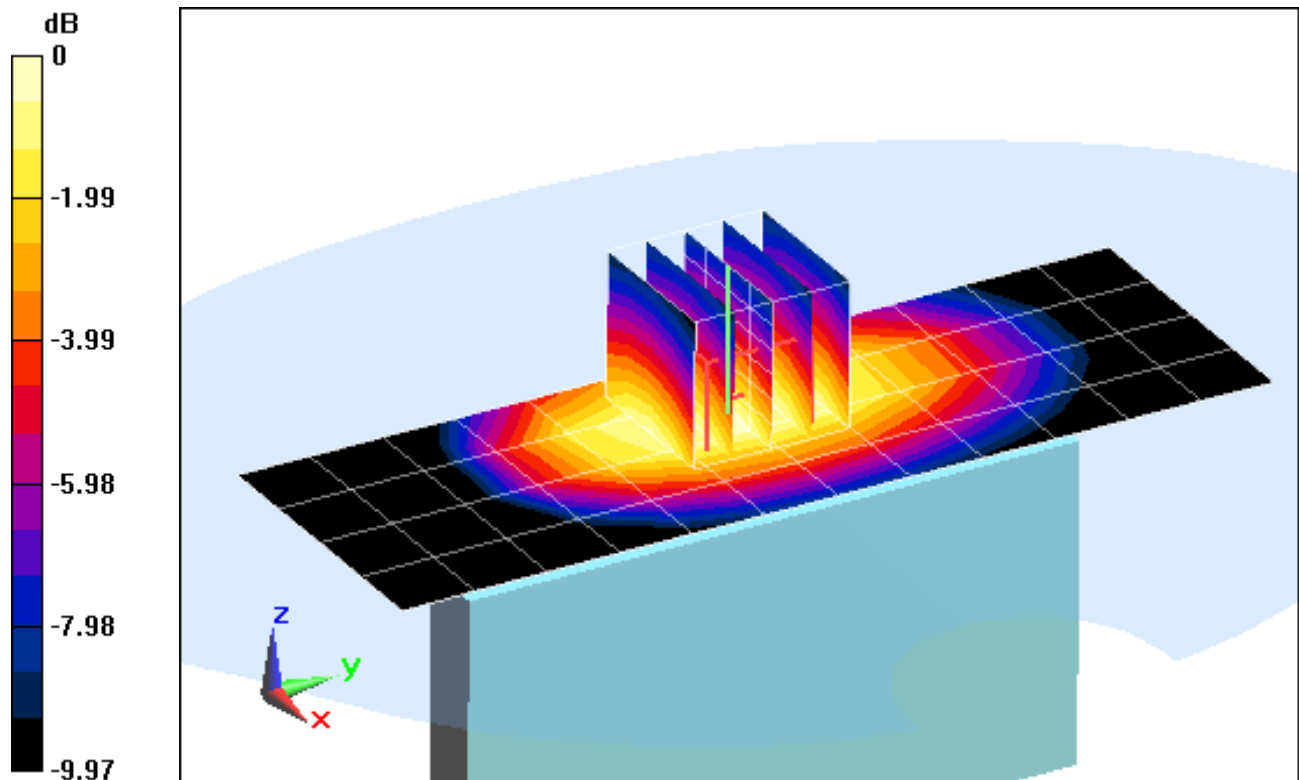

0 dB = 0.540mW/g = -5.35 dB mW/g