

APPENDIX A: SAR TEST DATA

PCTEST ENGINEERING LABORATORY, INC.

DUT: SAMSUNG A3LSCHA650; Type: Tri Mode Phone; S/N: FA-018-J
Program: SCH-A650 AMPS Mode

Communication System: AMPS; Frequency: 836.49 MHz; Duty Cycle: 1:1
Medium: 835 Brain ($\sigma = 0.89$ mho/m, $\epsilon_r = 41.48$, $\rho = 1000$ kg/m³)
Phantom section: Right Section

Test Date: 09-10-2003; Ambient Temp: 22.5°C; Tissue Temp: 20.6°C

Probe: ET3DV6 - SN1560; ConvF(6.9, 6.9, 6.9); Calibrated: 9/27/2002
Sensor-Surface: 4mm (Mechanical And Optical Surface Detection)
Electronics: DAE3 SN330; Calibrated: 12/1/2002
Phantom: SAM 12b; Type: SAM 4.0; Serial: TP:1197

Measurement SW: DASY4, V4.1 Build 47; Postprocessing SW: SEMCAD, V1.6 Build 115

Ch.0383, Touch, Ant.Out, Standard Battery

Area Scan (51x131x1): Measurement grid: dx=15mm, dy=15mm

Zoom Scan (7x7x7)/Cube 0: Measurement grid: dx=5mm, dy=5mm, dz=5mm

Peak SAR (extrapolated) = 2.06 W/kg

SAR(1 g) = 1.33 mW/g; SAR(10 g) = 0.819 mW/g

Reference Value = 9.72 V/m

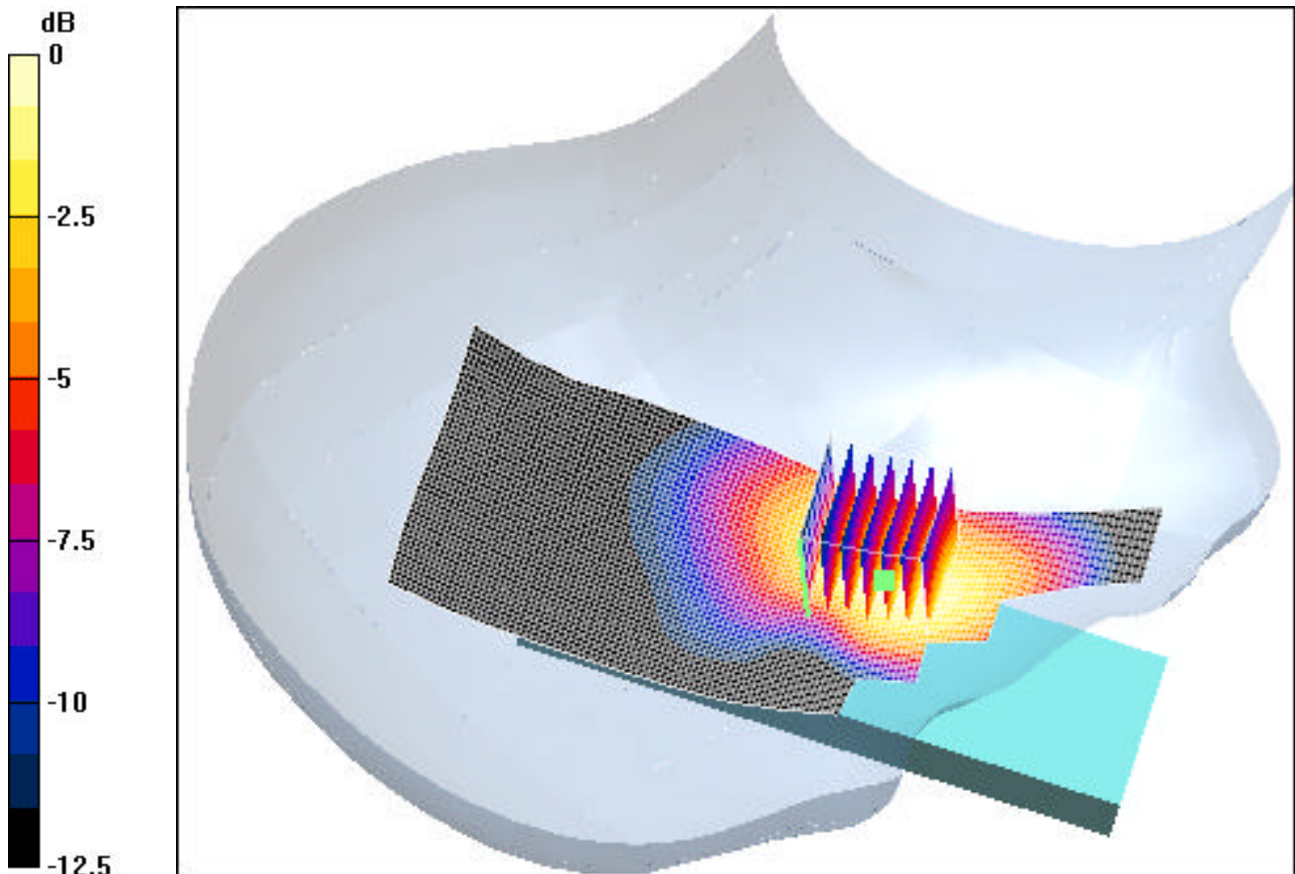

PCTEST ENGINEERING LABORATORY, INC.

DUT: SAMSUNG A3LSCHA650; Type: Tri Mode Phone; S/N: FA-018-J
Program: SCH-A650 AMPS Mode

Communication System: AMPS; Frequency: 836.49 MHz; Duty Cycle: 1:1
Medium: 835 Brain ($\sigma = 0.89$ mho/m, $\epsilon_r = 41.48$, $\rho = 1000$ kg/m³)
Phantom section: Right Section

Test Date: 09-10-2003; Ambient Temp: 22.5°C; Tissue Temp: 20.6°C

Probe: ET3DV6 - SN1560; ConvF(6.9, 6.9, 6.9); Calibrated: 9/27/2002
Sensor-Surface: 4mm (Mechanical And Optical Surface Detection)
Electronics: DAE3 SN330; Calibrated: 12/1/2002
Phantom: SAM 12b; Type: SAM 4.0; Serial: TP:1197

Measurement SW: DASY4, V4.1 Build 47; Postprocessing SW: SEMCAD, V1.6 Build 115

Ch.0383, Tilt, Ant.Out, Standard Battery

Area Scan (51x131x1): Measurement grid: dx=15mm, dy=15mm

Zoom Scan (7x7x7)/Cube 0: Measurement grid: dx=5mm, dy=5mm, dz=5mm

Peak SAR (extrapolated) = 0.348 W/kg

SAR(1 g) = 0.248 mW/g; SAR(10 g) = 0.177 mW/g

Reference Value = 8.73 V/m

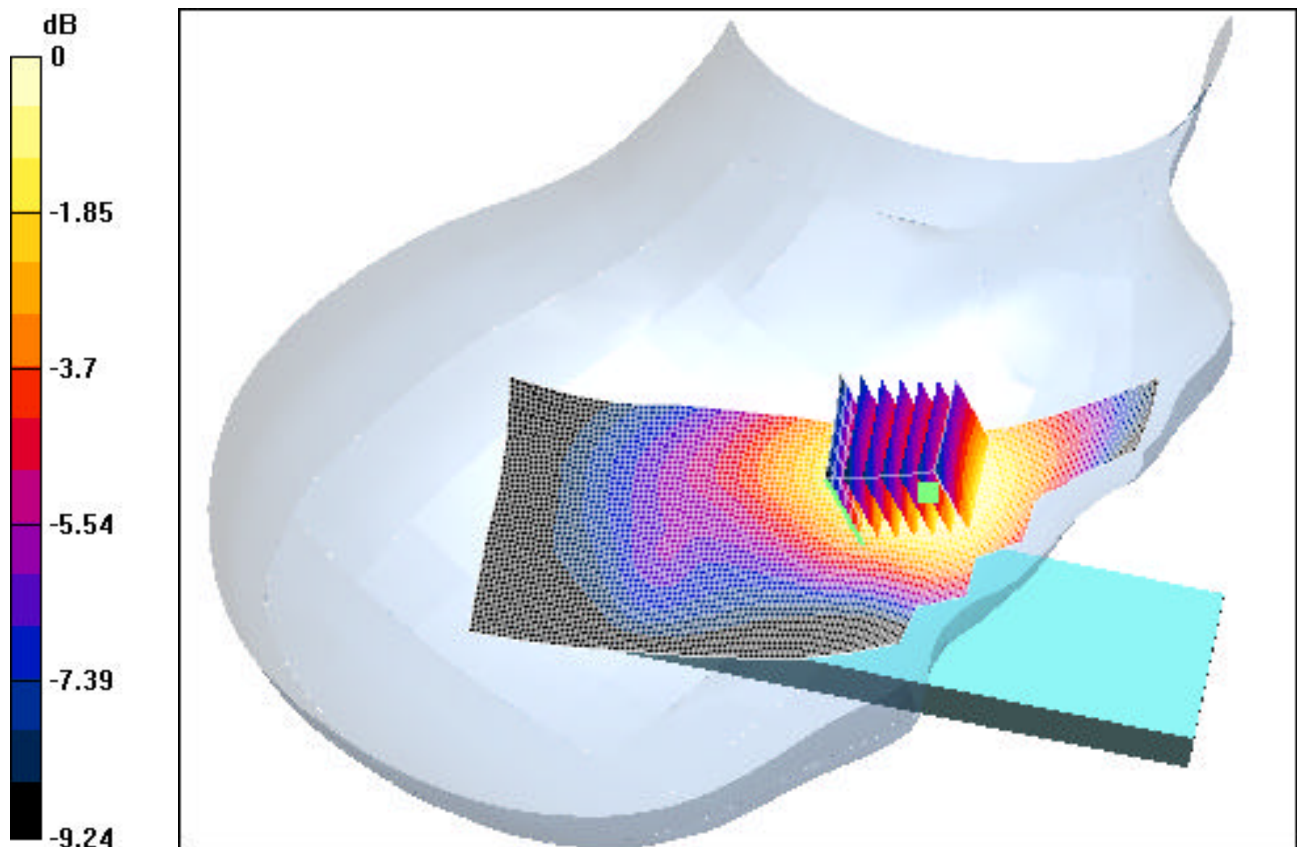

PCTEST ENGINEERING LABORATORY, INC.

DUT: SAMSUNG A3LSCH; Type: Tri Mode Phone; S/N: FA -018-J
Program: SCH-A650 AMPS Mode

Communication System: AMPS; Frequency: 836.49 MHz; Duty Cycle: 1:1
Medium: 835 Brain ($\sigma = 0.89$ mho/m, $\epsilon_r = 41.48$, $\rho = 1000$ kg/m³)
Phantom section: Left Section

Test Date: 09-10-2003; Ambient Temp: 22.5°C; Tissue Temp: 20.6°C

Probe: ET3DV6 - SN1560; ConvF(6.9, 6.9, 6.9); Calibrated: 9/27/2002
Sensor-Surface: 4mm (Mechanical And Optical Surface Detection)
Electronics: DAE3 SN330; Calibrated: 12/1/2002
Phantom: SAM 12b; Type: SAM 4.0; Serial: TP:1197

Measurement SW: DASY4, V4.1 Build 47; Postprocessing SW: SEMCAD, V1.6 Build 115

Ch.0383, Touch, Ant Out, Standard Battery

Area Scan (51x131x1): Measurement grid: dx=15mm, dy=15mm

Zoom Scan (7x7x7)/Cube 0: Measurement grid: dx=5mm, dy=5mm, dz=5mm

Peak SAR (extrapolated) = 1.75 W/kg

SAR(1 g) = 1.17 mW/g; SAR(10 g) = 0.747 mW/g

Reference Value = 8.18 V/m

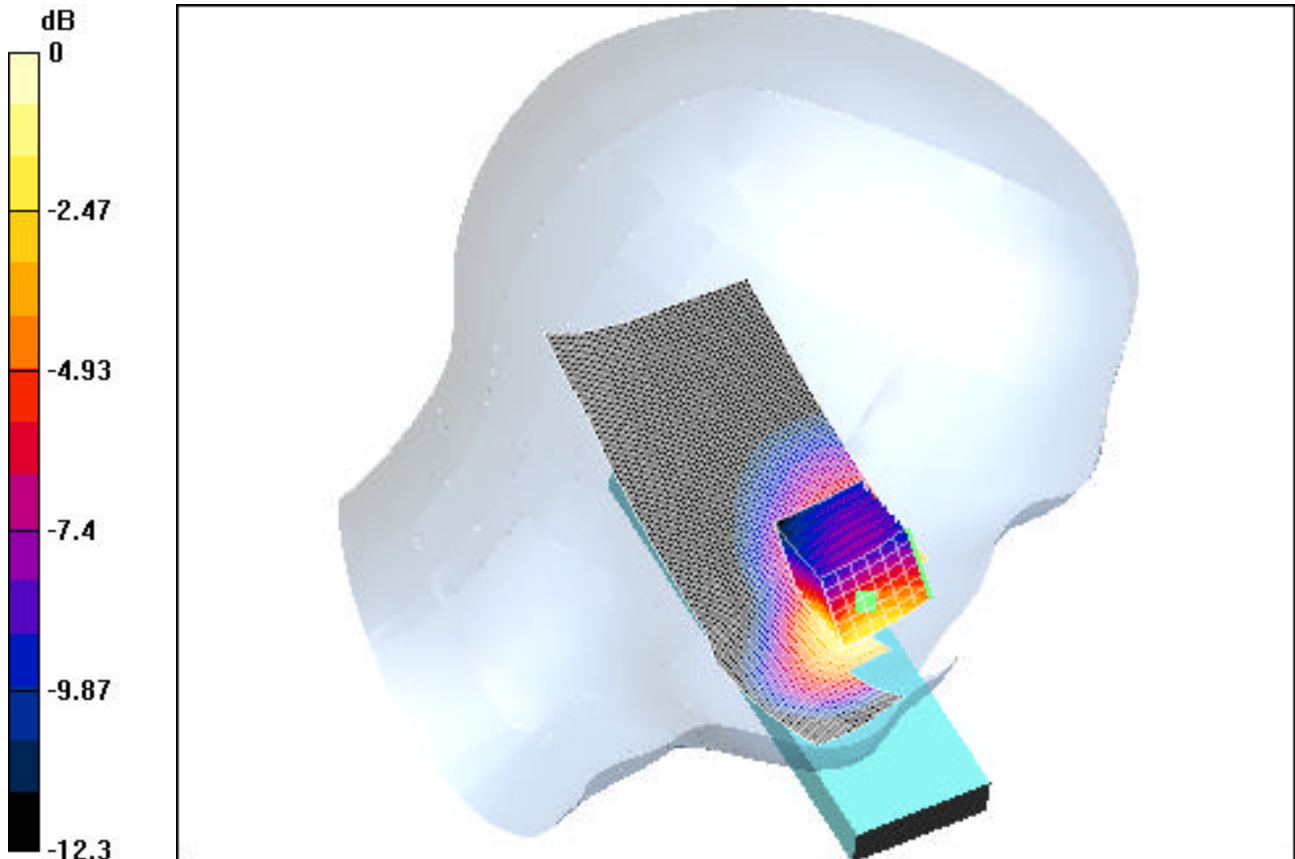

PCTEST ENGINEERING LABORATORY, INC.

DUT: SAMSUNG A3LSCHA650; Type: Tri Mode Phone; S/N: FA-018-J
Program: SCH-A650 AMPS Mode

Communication System: AMPS; Frequency: 836.49 MHz; Duty Cycle: 1:1
Medium: 835 Brain ($\sigma = 0.89$ mho/m, $\epsilon_r = 41.48$, $\rho = 1000$ kg/m³)
Phantom section: Left Section

Test Date: 09-10-2003; Ambient Temp: 22.5°C; Tissue Temp: 20.6°C

Probe: ET3DV6 - SN1560; ConvF(6.9, 6.9, 6.9); Calibrated: 9/27/2002
Sensor-Surface: 4mm (Mechanical And Optical Surface Detection)
Electronics: DAE3 SN330; Calibrated: 12/1/2002
Phantom: SAM 12b; Type: SAM 4.0; Serial: TP:1197

Measurement SW: DASY4, V4.1 Build 47; Postprocessing SW: SEMCAD, V1.6 Build 115

Ch.0383, Tilt, Ant Out, Standard Battery

Area Scan (51x131x1): Measurement grid: dx=15mm, dy=15mm

Zoom Scan (7x7x7)/Cube 0: Measurement grid: dx=5mm, dy=5mm, dz=5mm

Peak SAR (extrapolated) = 0.272 W/kg

SAR(1 g) = 0.203 mW/g; SAR(10 g) = 0.145 mW/g

Reference Value = 8.61 V/m.

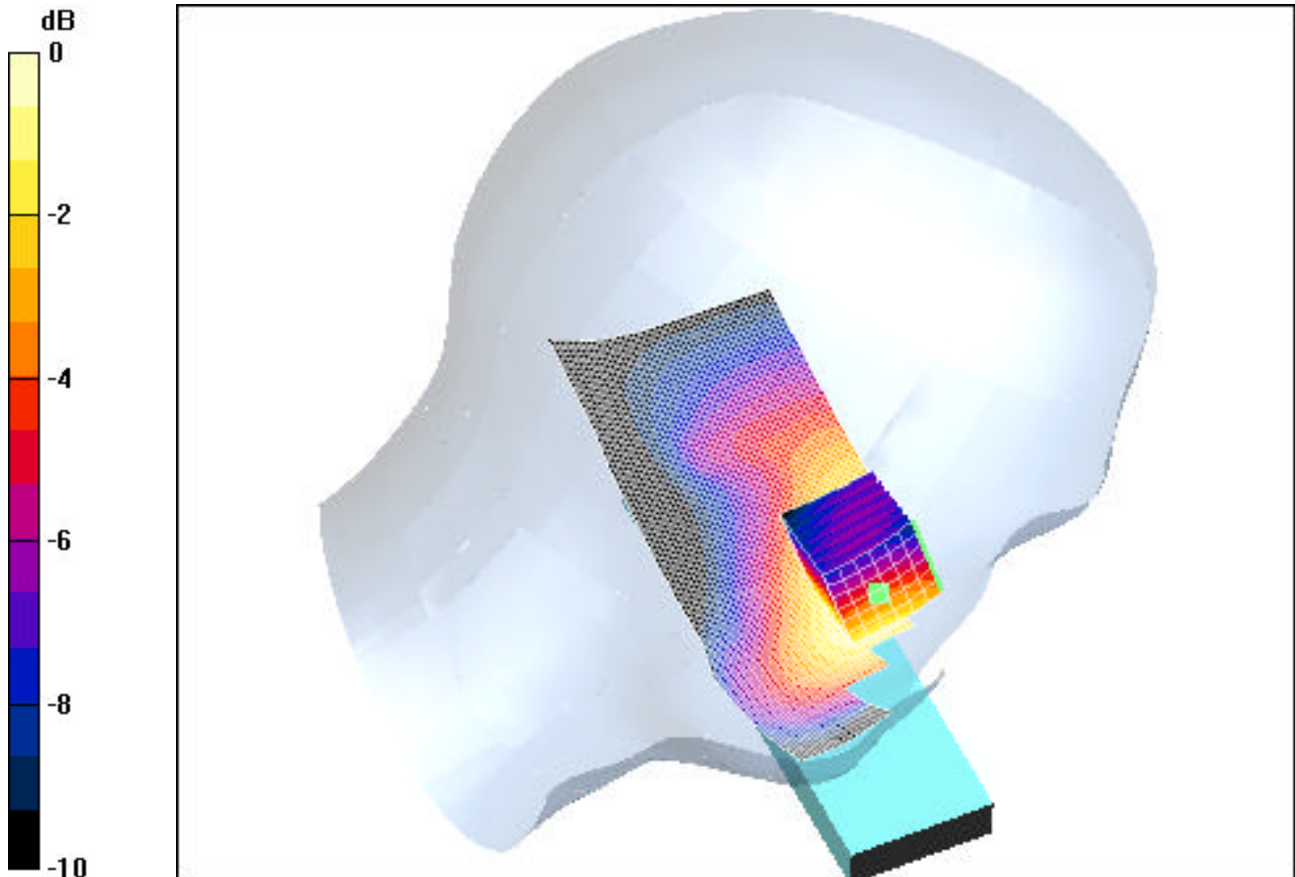

PCTEST ENGINEERING LABORATORY, INC.

DUT: SAMSUNG A3LSCHA650; Type: Tri Mode Phone; S/N: FA-018-J
Program: SCH-A650 CDMA Mode

Communication System: Cellular CDMA; Frequency: 835.89 MHz; Duty Cycle: 1:1
Medium: 835 Brain ($\sigma = 0.89$ mho/m, $\epsilon_r = 41.48$, $\rho = 1000$ kg/m³)
Phantom section: Right Section

Test Date: 09-11-2003; Ambient Temp: 22.8°C; Tissue Temp: 20.6°C

Probe: ET3DV6 - SN1560; ConvF(6.9, 6.9, 6.9); Calibrated: 9/27/2002
Sensor-Surface: 4mm (Mechanical And Optical Surface Detection)
Electronics: DAE3 SN330; Calibrated: 12/1/2002
Phantom: SAM 12b; Type: SAM 4.0; Serial: TP:1197

Measurement SW: DASY4, V4.1 Build 47; Postprocessing SW: SEMCAD, V1.6 Build 115

Ch.0363, Touch, Ant.Out, Standard Battery

Area Scan (51x131x1): Measurement grid: dx=15mm, dy=15mm

Zoom Scan (7x7x7)/Cube 0: Measurement grid: dx=5mm, dy=5mm, dz=5mm

Peak SAR (extrapolated) = 1.56 W/kg

SAR(1 g) = 0.999 mW/g; SAR(10 g) = 0.616 mW/g

Reference Value = 8.57 V/m

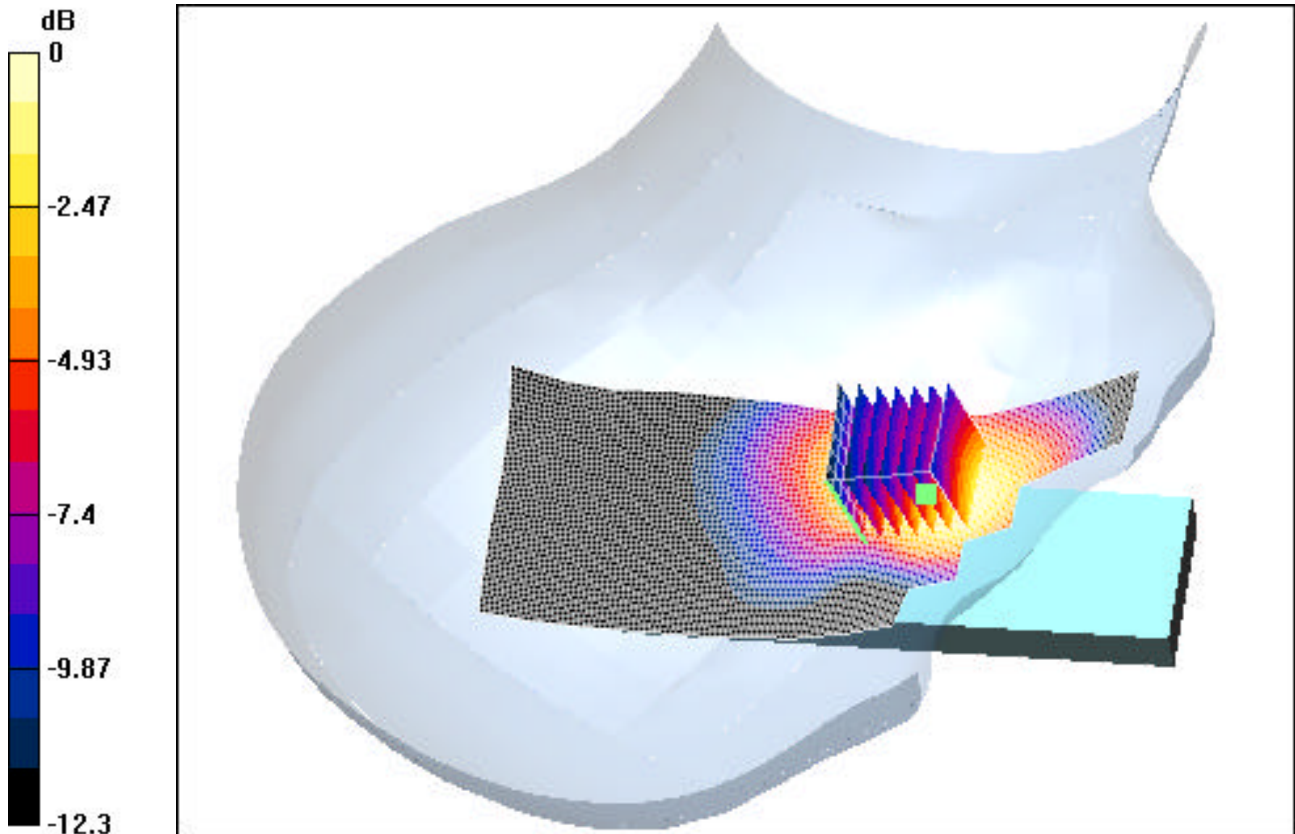

PCTEST ENGINEERING LABORATORY, INC.

DUT: SAMSUNG A3LSCHA650; Type: Tri Mode Phone; S/N: FA-018-J
Program: A3LSCHA650 CDMA Mode

Communication System: Cellular CDMA; Frequency: 835.89 MHz; Duty Cycle: 1:1
Medium: 835 Brain ($\sigma = 0.89$ mho/m, $\epsilon_r = 41.48$, $\rho = 1000$ kg/m³)
Phantom section: Right Section

Test Date: 09-11-2003; Ambient Temp: 22.8°C; Tissue Temp: 20.6°C

Probe: ET3DV6 - SN1560; ConvF(6.9, 6.9, 6.9); Calibrated: 9/27/2002
Sensor-Surface: 4mm (Mechanical And Optical Surface Detection)
Electronics: DAE3 SN330; Calibrated: 12/1/2002
Phantom: SAM 12b; Type: SAM 4.0; Serial: TP:1197

Measurement SW: DASY4, V4.1 Build 47; Postprocessing SW: SEMCAD, V1.6 Build 115

Ch.0363, Tilt, Ant.Out, Standard Battery

Area Scan (51x131x1): Measurement grid: dx=15mm, dy=15mm

Zoom Scan (7x7x7)/Cube 0: Measurement grid: dx=5mm, dy=5mm, dz=5mm

Peak SAR (extrapolated) = 0.228 W/kg

SAR(1 g) = 0.171 mW/g; SAR(10 g) = 0.124 mW/g

Reference Value = 7.72 V/m

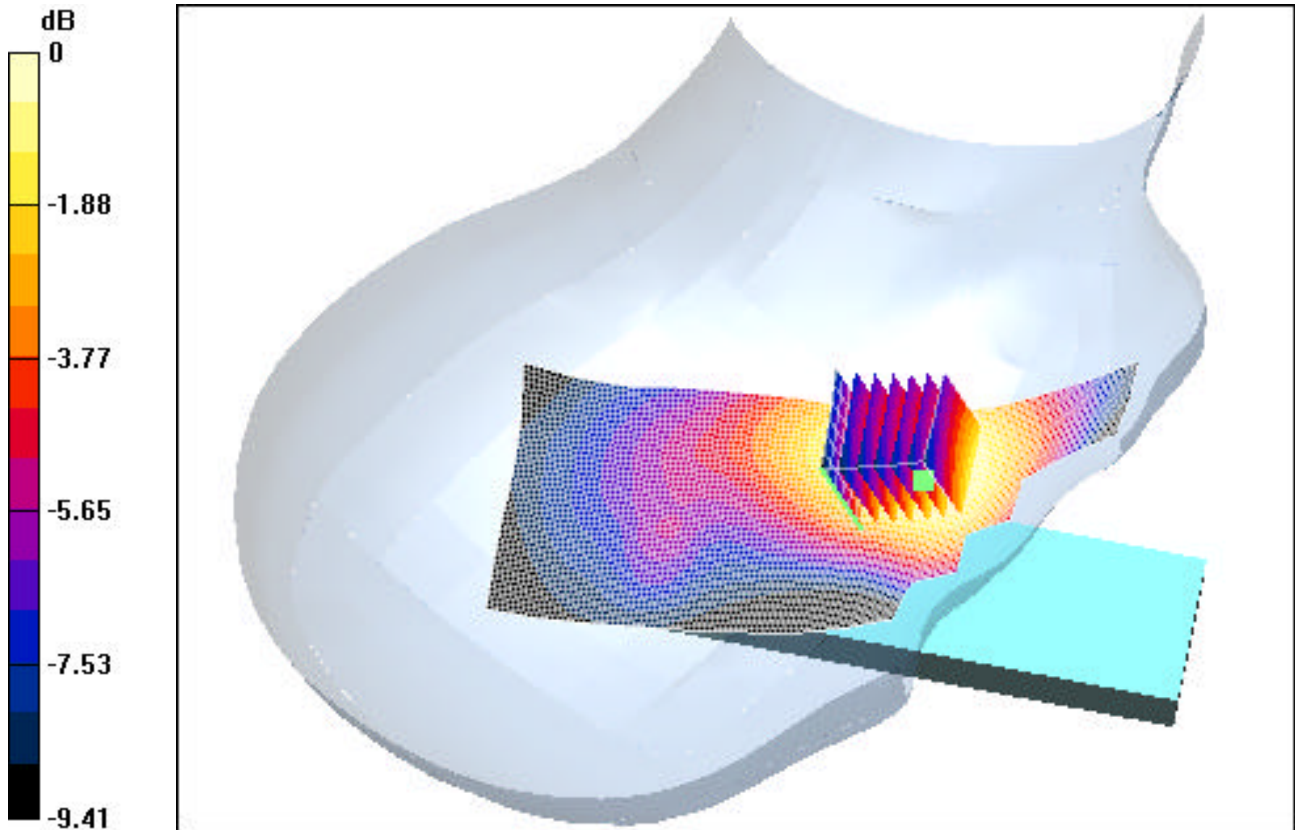

PCTEST ENGINEERING LABORATORY, INC.

DUT: SAMSUNG A3LCSHA650; Type: Tri Mode Phone; S/N: FA-018-J
Program: SCH-A650 CDMA Mode

Communication System: Cellular CDMA; Frequency: 835.89 MHz; Duty Cycle: 1:1
Medium: 835 Brain ($\sigma = 0.89$ mho/m, $\epsilon_r = 41.48$, $\rho = 1000$ kg/m³)
Phantom section: Left Section

Test Date: 09-11-2003; Ambient Temp: 22.8°C; Tissue Temp: 20.6°C

Probe: ET3DV6 - SN1560; ConvF(6.9, 6.9, 6.9); Calibrated: 9/27/2002
Sensor-Surface: 4mm (Mechanical And Optical Surface Detection)
Electronics: DAE3 SN330; Calibrated: 12/1/2002
Phantom: SAM 12b; Type: SAM 4.0; Serial: TP:1197

Measurement SW: DASY4, V4.1 Build 47; Postprocessing SW: SEMCAD, V1.6 Build 115

Ch.0363, Touch, Ant Out, Standard Battery

Area Scan (51x131x1): Measurement grid: dx=15mm, dy=15mm

Zoom Scan (7x7x7)/Cube 0: Measurement grid: dx=5mm, dy=5mm, dz=5mm

Peak SAR (extrapolated) = 1.35 W/kg

SAR(1 g) = 0.878 mW/g; SAR(10 g) = 0.552 mW/g

Reference Value = 7.25 V/m

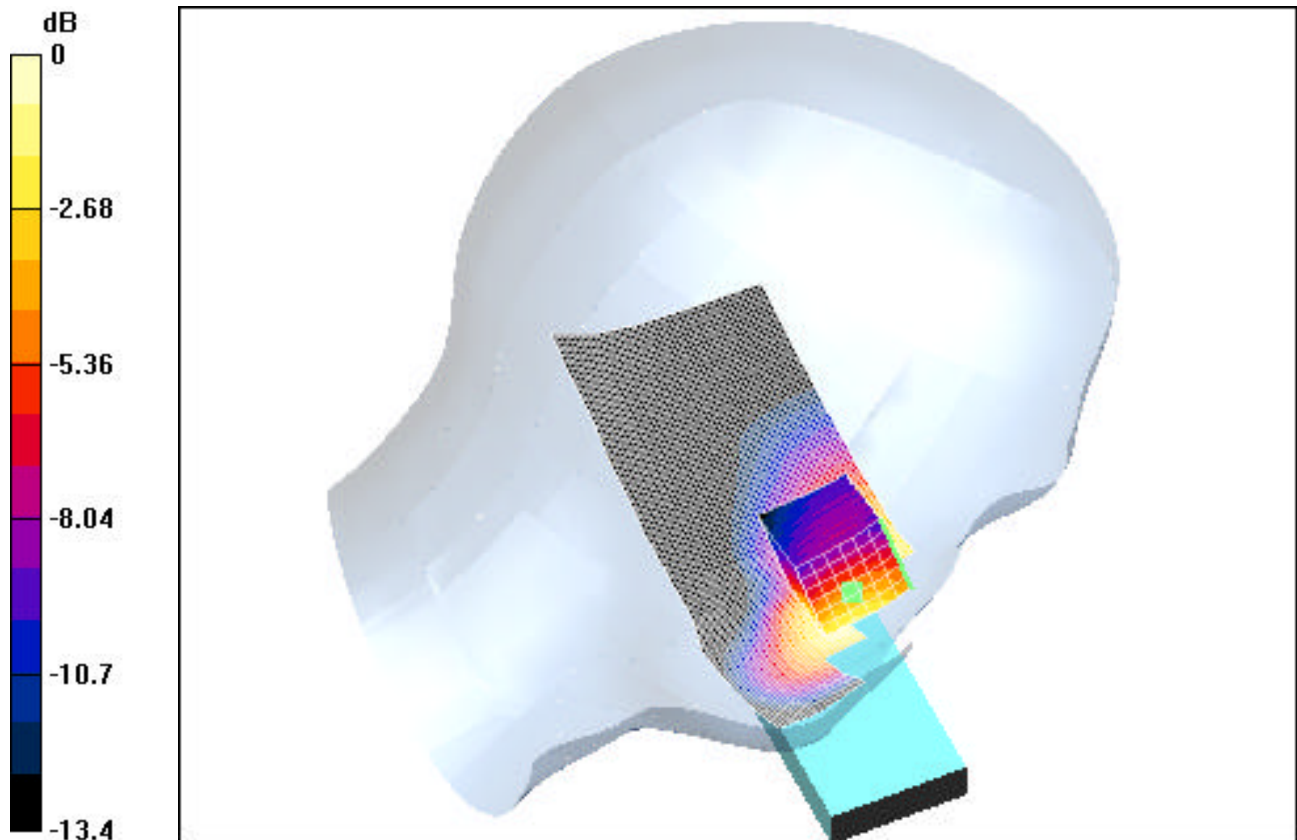

PCTEST ENGINEERING LABORATORY, INC.

DUT: SAMSUNG A3LSCHA650; Type: Tri Mode Phone; S/N: FA-018-J
Program: SCH-A650 CDMA Mode

Communication System: Cellular CDMA; Frequency: 835.89 MHz; Duty Cycle: 1:1
Medium: 835 Brain ($\sigma = 0.89$ mho/m, $\epsilon_r = 41.48$, $\rho = 1000$ kg/m³)
Phantom section: Left Section

Test Date: 09-11-2003; Ambient Temp: 22.8°C; Tissue Temp: 20.6°C

Probe: ET3DV6 - SN1560; ConvF(6.9, 6.9, 6.9); Calibrated: 9/27/2002
Sensor-Surface: 4mm (Mechanical And Optical Surface Detection)
Electronics: DAE3 SN330; Calibrated: 12/1/2002
Phantom: SAM 12b; Type: SAM 4.0; Serial: TP:1197

Measurement SW: DASY4, V4.1 Build 47; Postprocessing SW: SEMCAD, V1.6 Build 115

Ch.0363, Tilt, Ant Out, Standard Battery

Area Scan (51x131x1): Measurement grid: dx=15mm, dy=15mm

Zoom Scan (7x7x7)/Cube 0: Measurement grid: dx=5mm, dy=5mm, dz=5mm

Peak SAR (extrapolated) = 0.184 W/kg

SAR(1 g) = 0.133 mW/g; SAR(10 g) = 0.0929 mW/g

Reference Value = 5.52 V/m

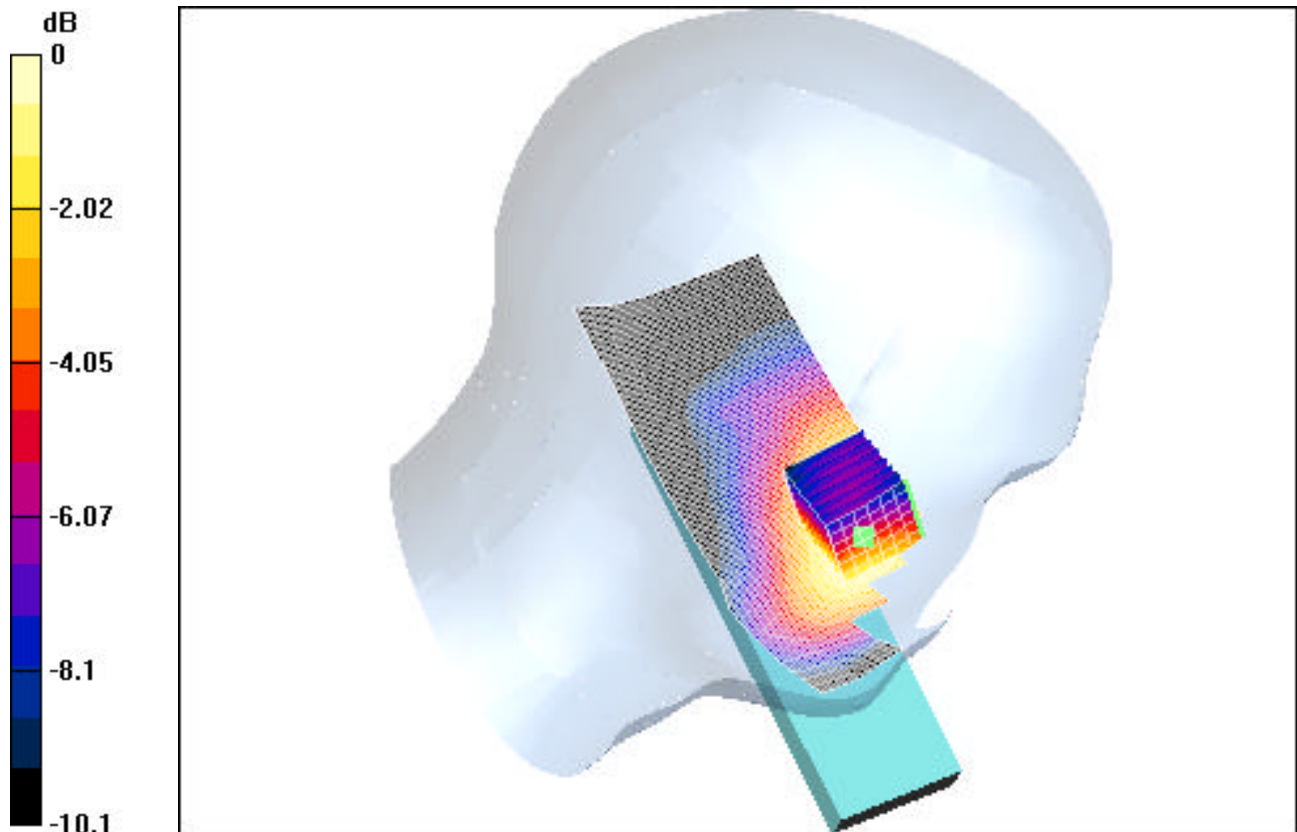

PCTEST ENGINEERING LABORATORY, INC.

DUT: SAMSUNG A3LSCHA650; Type: Tri Mode Phone; S/N: FA-018-J
Program: SCH-A650 PCS Mode

Communication System: PCS CDMA; Frequency: 1851.25 MHz; Duty Cycle: 1:1
Medium: 1900 Brain ($\sigma = 1.37$ mho/m, $\xi = 39.34$, $\rho = 1000$ kg/m³)
Phantom section: Right Section

Test Date: 09-08-2003; Ambient Temp: 22.7°C; Tissue Temp: 20.1°C

Probe: ET3DV6 - SN1560; ConvF(5.4, 5.4, 5.4); Calibrated: 9/27/2002
Sensor-Surface: 4mm (Mechanical And Optical Surface Detection)
Electronics: DAE3 SN330; Calibrated: 12/1/2002
Phantom: SAM 12b; Type: SAM 4.0; Serial: TP:1197

Measurement SW: DASY4, V4.1 Build 47; Postprocessing SW: SEMCAD, V1.6 Build 115

Ch.0025, Touch, Ant.In, Standard Battery

Area Scan (51x121x1): Measurement grid: dx=15mm, dy=15mm

Zoom Scan (7x7x7)/Cube 0: Measurement grid: dx=5mm, dy=5mm, dz=5mm

Peak SAR (extrapolated) = 1.91 W/kg

SAR(1 g) = 0.953 mW/g; SAR(10 g) = 0.459 mW/g

Reference Value = 5.48 V/m

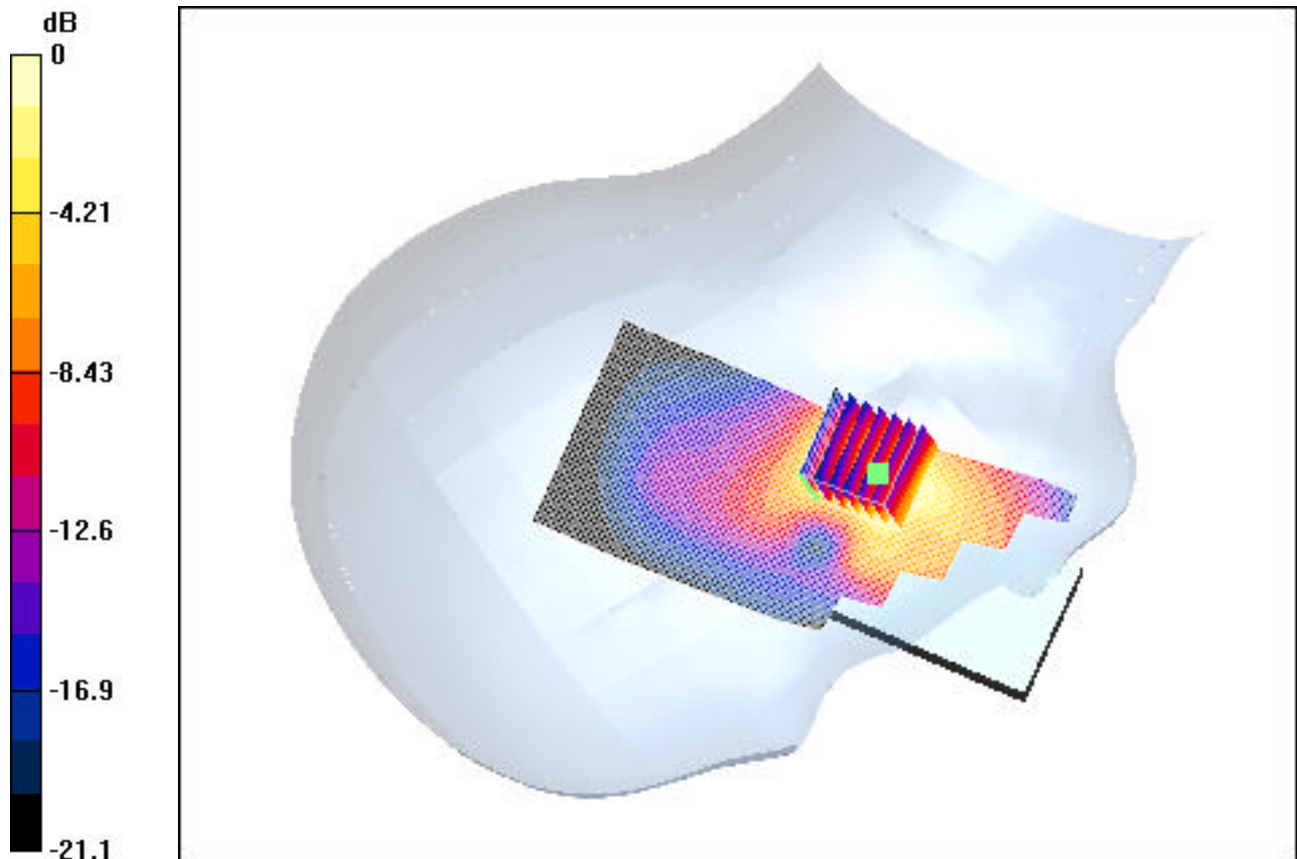

PCTEST ENGINEERING LABORATORY, INC.

DUT: SAMSUNG A3LSCHA650; Type: Tri Mode Phone; S/N: FA-018-J
Program: SCH-A650 PCS Mode

Communication System: PCS CDMA; Frequency: 1880 MHz; Duty Cycle: 1:1
Medium: 1900 Brain ($\sigma = 1.37$ mho/m, $\xi = 39.34$, $\rho = 1000$ kg/m³)
Phantom section: Right Section

Test Date: 09-08-2003; Ambient Temp: 22.7°C; Tissue Temp: 20.1°C

Probe: ET3DV6 - SN1560; ConvF(5.4, 5.4, 5.4); Calibrated: 9/27/2002
Sensor-Surface: 4mm (Mechanical And Optical Surface Detection)
Electronics: DAE3 SN330; Calibrated: 12/1/2002
Phantom: SAM 12b; Type: SAM 4.0; Serial: TP:1197

Measurement SW: DASY4, V4.1 Build 47; Postprocessing SW: SEMCAD, V1.6 Build 115

Ch,0600, Tilt, Ant.In, Standard Battery

Area Scan (51x121x1): Measurement grid: dx=15mm, dy=15mm

Zoom Scan (7x7x7)/Cube 0: Measurement grid: dx=5mm, dy=5mm, dz=5mm

Peak SAR (extrapolated) = 0.156 W/kg

SAR(1 g) = 0.098 mW/g; SAR(10 g) = 0.058 mW/g

Reference Value = 8.68 V/m

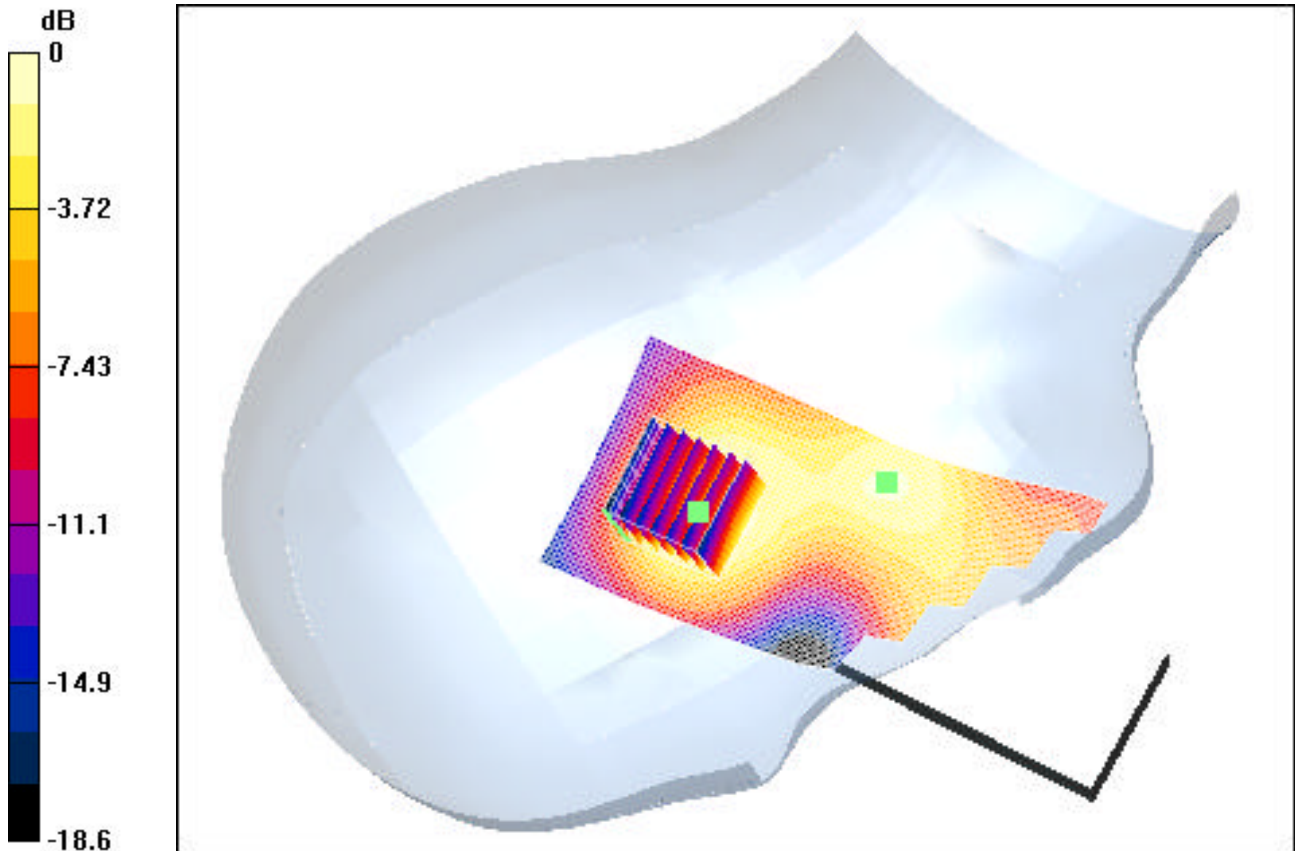

PCTEST ENGINEERING LABORATORY, INC.

DUT: SAMSUNG A3LSCHA650; Type: Tri Mode Phone; S/N: FA-018-J
Program: SCH-A650 PCS Mode

Communication System: PCS CDMA; Frequency: 1851.25 MHz; Duty Cycle: 1:1
Medium: 1900 Brain ($\sigma = 1.37$ mho/m, $\epsilon = 39.34$, $\rho = 1000$ kg/m³)
Phantom section: Left Section

Test Date: 09-09-2003; Ambient Temp: 22.8°C; Tissue Temp: 20.1°C

Probe: ET3DV6 - SN1560; ConvF(5.4, 5.4, 5.4); Calibrated: 9/27/2002
Sensor-Surface: 4mm (Mechanical And Optical Surface Detection)
Electronics: DAE3 SN330; Calibrated: 12/1/2002
Phantom: SAM 12b; Type: SAM 4.0; Serial: TP:1197

Measurement SW: DASY4, V4.1 Build 47; Postprocessing SW: SEMCAD, V1.6 Build 115

Ch.0025, Touch, Ant.In, Standard Battery

Area Scan (51x121x1): Measurement grid: dx=15mm, dy=15mm

Zoom Scan (7x7x7)/Cube 0: Measurement grid: dx=5mm, dy=5mm, dz=5mm

Peak SAR (extrapolated) = 1.86 W/kg

SAR(1 g) = 0.971 mW/g; SAR(10 g) = 0.484 mW/g

Reference Value = 5.87 V/m

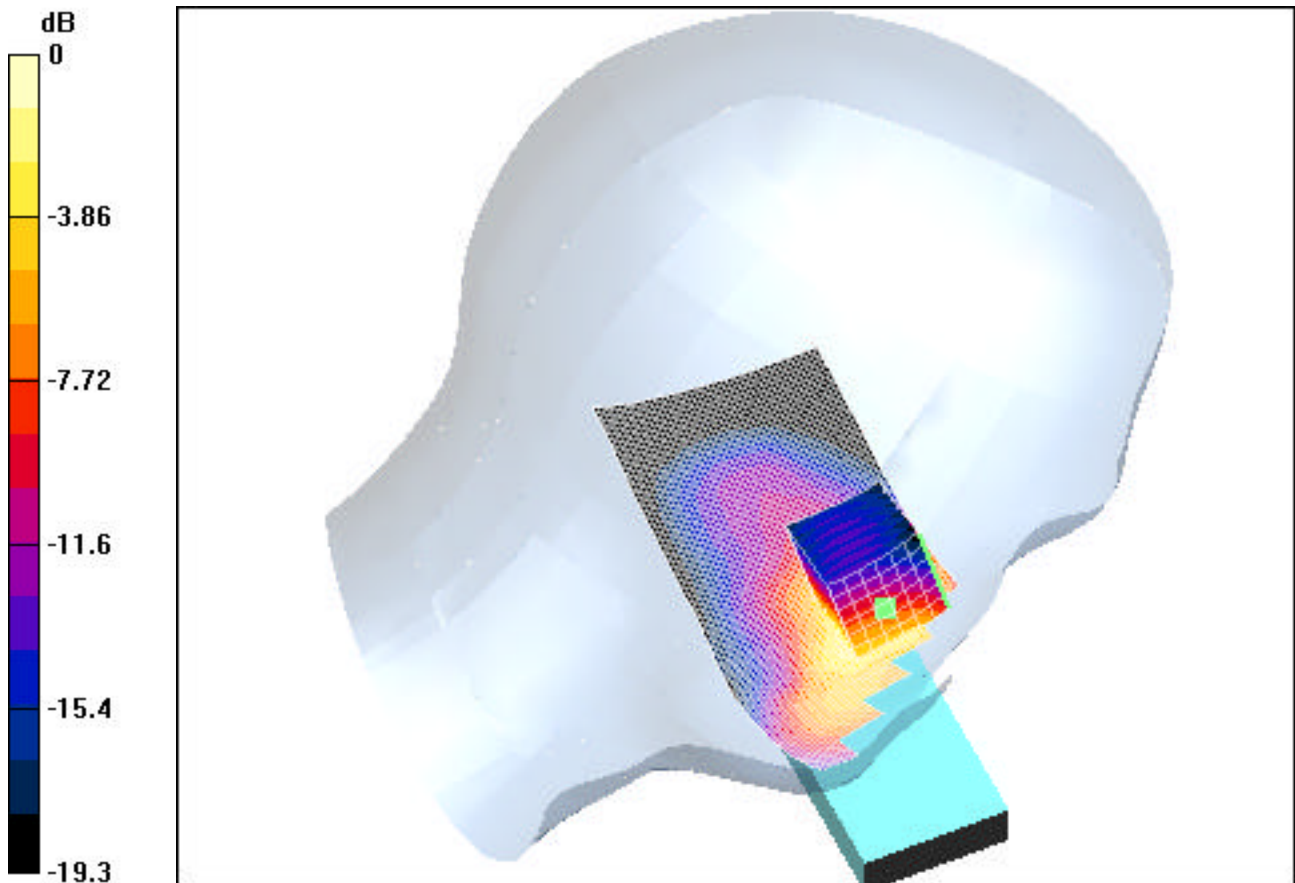

PCTEST ENGINEERING LABORATORY, INC.

DUT: SAMSUNG A3LSCHA650; Type: Tri Mode Phone; S/N: FA-018-J
Program: SCH-A650 PCS Mode

Communication System: PCS CDMA; Frequency: 1880 MHz; Duty Cycle: 1:1
Medium: 1900 Brain ($\sigma = 1.37$ mho/m, $\xi = 39.34$, $\rho = 1000$ kg/m³)
Phantom section: Left Section

Test Date: 09-09-2003; Ambient Temp: 22.8°C; Tissue Temp: 20.1°C

Probe: ET3DV6 - SN1560; ConvF(5.4, 5.4, 5.4); Calibrated: 9/27/2002
Sensor-Surface: 4mm (Mechanical And Optical Surface Detection)
Electronics: DAE3 SN330; Calibrated: 12/1/2002
Phantom: SAM 12b; Type: SAM 4.0; Serial: TP:1197

Measurement SW: DASY4, V4.1 Build 47; Postprocessing SW: SEMCAD, V1.6 Build 115

Ch.0600,Tilt, Ant.In, Standard Battery

Area Scan (51x121x1): Measurement grid: dx=15mm, dy=15mm

Zoom Scan (7x7x7)/Cube 0: Measurement grid: dx=5mm, dy=5mm, dz=5mm

Peak SAR (extrapolated) = 0.139 W/kg

SAR(1 g) = 0.089 mW/g; SAR(10 g) = 0.053 mW/g

Reference Value = 7.69 V/m

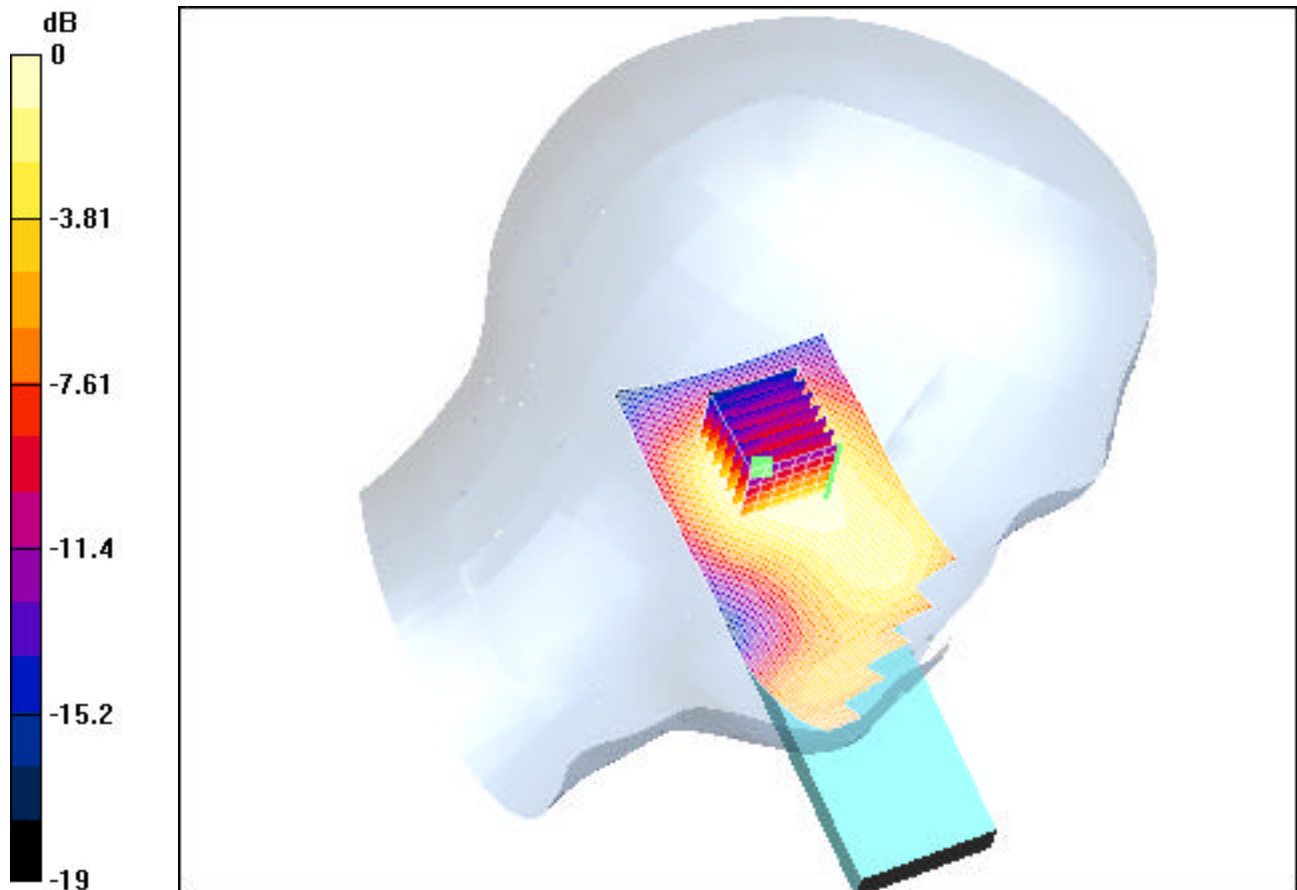

PCTEST ENGINEERING LABORATORY, INC.

DUT: SAMSUNG A3LSCHA650; Type: Tri Mode Phone; Serial: FA-018-J
Program: SCH-A650 AMPS Mode; Body

Communication System: AMPS; Frequency: 824.04 MHz; Duty Cycle: 1:1
Medium: 835 Muscle ($\sigma = 0.98$ mho/m, $\epsilon_r = 52.95$, $\rho = 1000$ kg/m³)
Phantom section: Flat Section

Test Date: 09-11-2003; Ambient Temp: 22.9°C; Tissue Temp: 20.5°C

Probe: ET3DV6 - SN1560; ConvF(6.6, 6.6, 6.6); Calibrated: 9/27/2002
Sensor-Surface: 4mm (Mechanical And Optical Surface Detection)
Electronics: DAE3 SN330; Calibrated: 12/1/2002
Phantom: SAM 12b; Type: SAM 4.0; Serial: TP:1197

Measurement SW: DASY4, V4.1 Build 47; Postprocessing SW: SEMCAD, V1.6 Build 115

Ch.0991, Ant Out, Standard Battery, w/ Beltclip, Space 1.8cm,

Area Scan (51x141x1): Measurement grid: dx=15mm, dy=15mm

Ch.0991, Ant Out, Standard Battery/Zoom Scan (7x7x7)/Cube 0: Measurement grid: dx=5mm,
dy=5mm, dz=5mm

Peak SAR (extrapolated) = 1.48 W/kg

SAR(1 g) = 1.12 mW/g; SAR(10 g) = 0.788 mW/g

Reference Value = 32.2 V/m

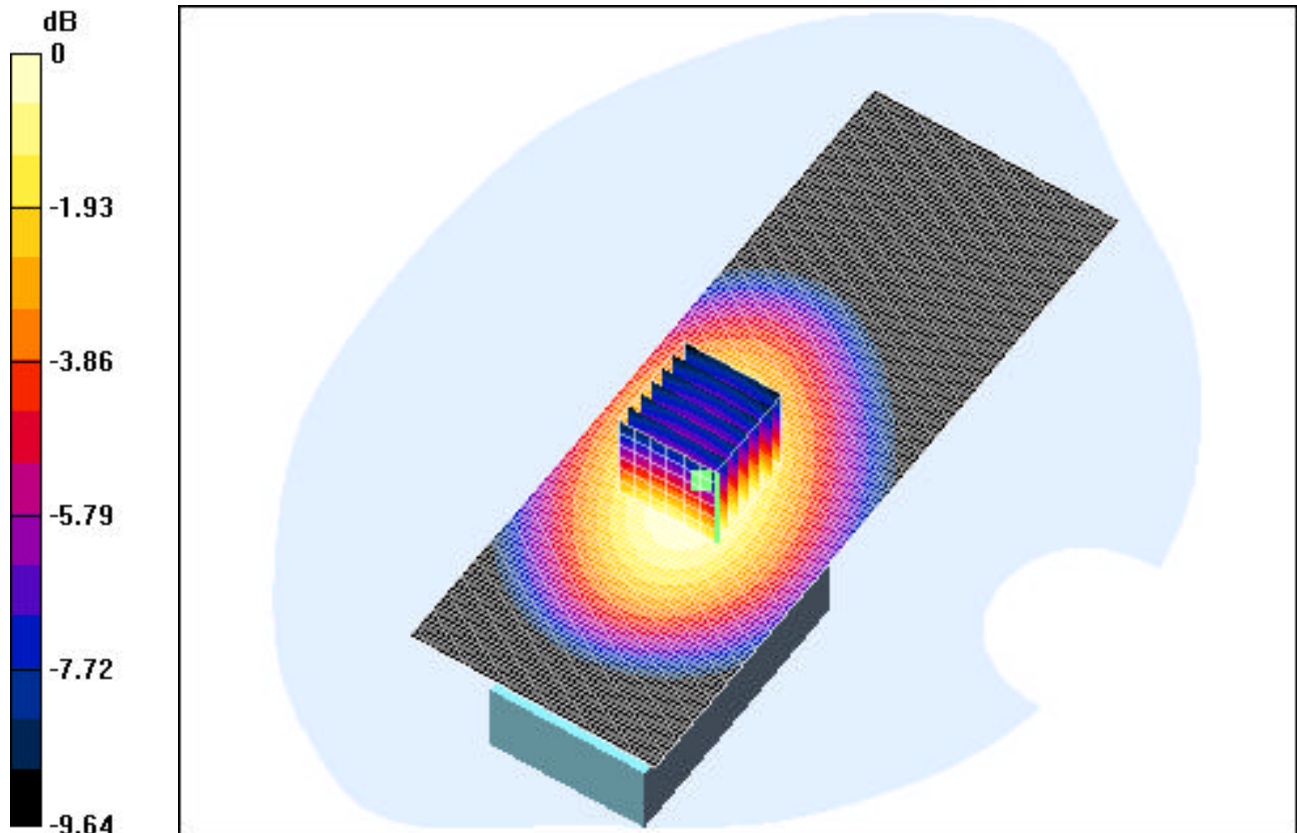

PCTEST ENGINEERING LABORATORY, INC.

DUT: SAMSUNG A3LSCHA650; Type: Tri Mode Phone; S/N: FA-018-J
Program: SCH-A650 CDMA Mode; Body

Communication System: Cellular CDMA; Frequency: 835.89 MHz; Duty Cycle: 1:1
Medium: 835 Muscle ($\sigma = 0.98$ mho/m, $\epsilon_r = 52.95$, $\rho = 1000$ kg/m³)
Phantom section: Flat Section

Test Date: 09-12-2003; Ambient Temp: 22.9°C; Tissue Temp: 20.5°C

Probe: ET3DV6 - SN1560; ConvF(6.6, 6.6, 6.6); Calibrated: 9/27/2002
Sensor-Surface: 4mm (Mechanical And Optical Surface Detection)
Electronics: DAE3 SN330; Calibrated: 12/1/2002
Phantom: SAM 12b; Type: SAM 4.0; Serial: TP:1197

Measurement SW: DASY4, V4.1 Build 47; Postprocessing SW: SEMCAD, V1.6 Build 115

Ch.0363, Ant Out, Standard Battery, w/ Beltclip, Space 1.8cm.

Area Scan (51x141x1): Measurement grid: dx=15mm, dy=15mm
Zoom Scan (7x7x7)/Cube 0: Measurement grid: dx=5mm, dy=5mm, dz=5mm
Peak SAR (extrapolated) = 1.22 W/kg
SAR(1 g) = 0.906 mW/g; SAR(10 g) = 0.631 mW/g
Reference Value = 28.1 V/m

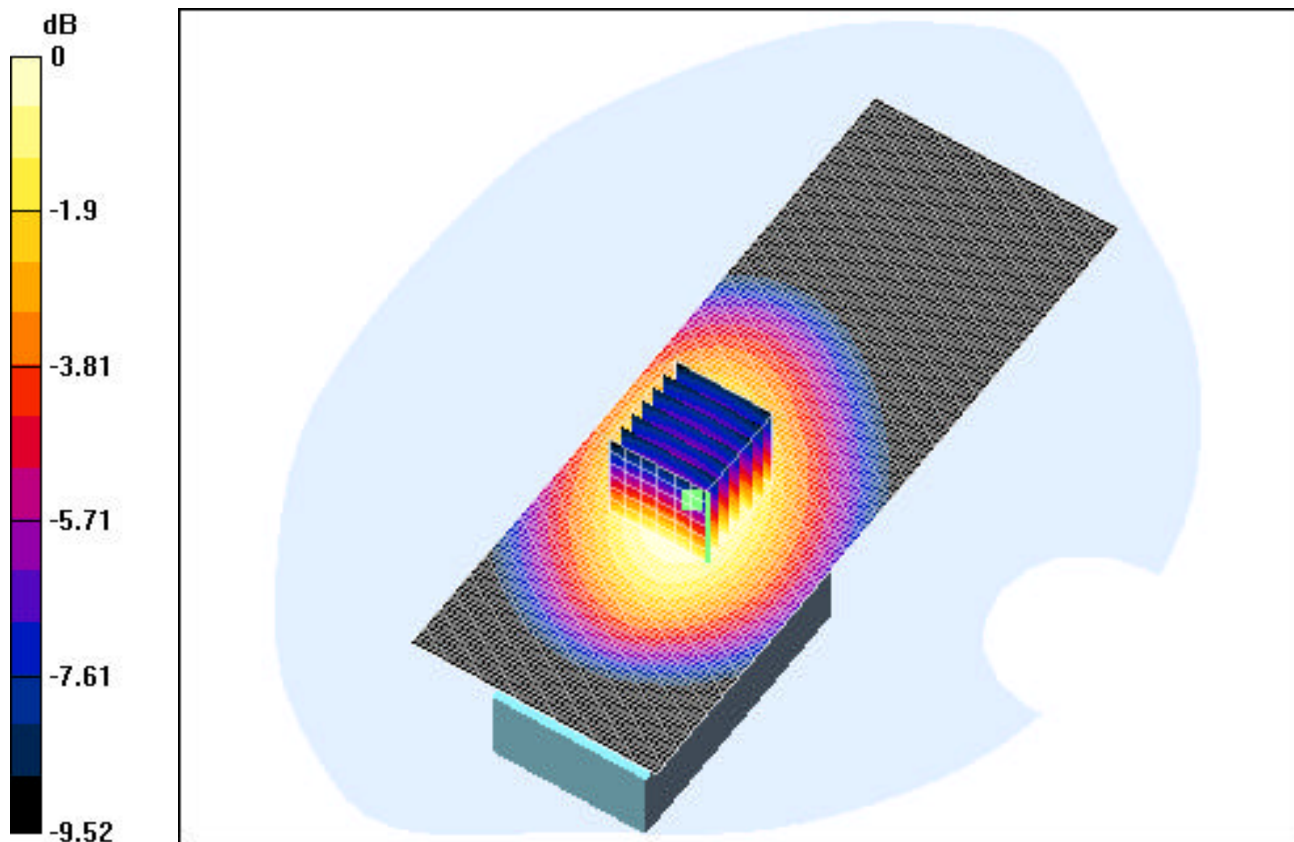

PCTEST ENGINEERING LABORATORY, INC.

DUT: SAMSUNG A3LSCHA650; Type: Tri Mode Phone; S/N: FA-018-J
Program: SCH-A650 PCS Mode; Body

Communication System: PCS CDMA; Frequency: 1851.25 MHz; Duty Cycle: 1:1
Medium: 1900 Muscle ($\sigma = 1.57$ mho/m, $\epsilon_r = 51.02$, $\rho = 1000$ kg/m³)
Phantom section: Flat Section

Test Date: 09-12-2003; Ambient Temp: 22.7°C; Tissue Temp: 20.4°C

Probe: ET3DV6 - SN1560; ConvF(4.9, 4.9, 4.9); Calibrated: 9/27/2002
Sensor-Surface: 4mm (Mechanical And Optical Surface Detection)
Electronics: DAE3 SN330; Calibrated: 12/1/2002
Phantom: SAM 12b; Type: SAM 4.0; Serial: TP:1197

Measurement SW: DASY4, V4.1 Build 47; Postprocessing SW: SEMCAD, V1.6 Build 115

Ch.0025, Ant Out, Standard Battery, w/ Beltclip, Space 1.8cm.

Area Scan (51x141x1): Measurement grid: dx=15mm, dy=15mm

Zoom Scan (7x7x7)/Cube 0: Measurement grid: dx=5mm, dy=5mm, dz=5mm

Peak SAR (extrapolated) = 0.715 W/kg

SAR(1 g) = 0.426 mW/g; SAR(10 g) = 0.247 mW/g

Reference Value = 11.6 V/m

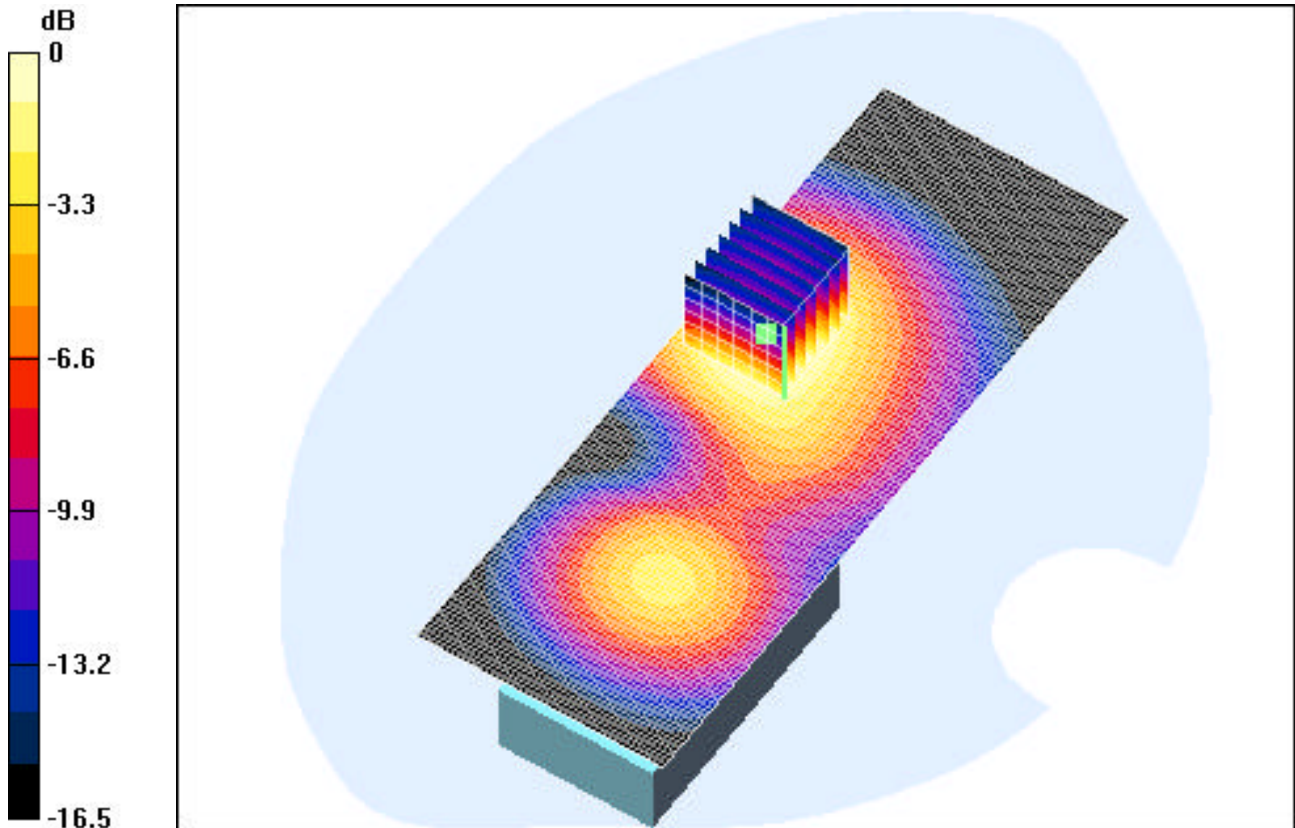

PCTEST ENGINEERING LABORATORY, INC.

DUT: SAMSUNG A3LSCHA650; Type: Tri Mode Phone; S/N: FA-018-J
Program: SCH-650 AMPS Mode

Communication System: AMPS; Frequency: 836.49 MHz; Duty Cycle: 1:1
Medium: 835 Brain ($\sigma = 0.89$ mho/m, $\epsilon_r = 41.48$, $\rho = 1000$ kg/m³)
Phantom section: Right Section

Test Date: 09-10-2003; Ambient Temp: 22.5°C; Tissue Temp: 20.6°C

Probe: ET3DV6 - SN1560; ConvF(6.9, 6.9, 6.9); Calibrated: 9/27/2002
Sensor-Surface: 4mm (Mechanical And Optical Surface Detection)
Electronics: DAE3 SN330; Calibrated: 12/1/2002
Phantom: SAM 12b; Type: SAM 4.0; Serial: TP:1197

Measurement SW: DASY4, V4.1 Build 47; Postprocessing SW: SEMCAD, V1.6 Build 115

Ch.0383, Touch, Ant.Out, Standard Battery

Area Scan (51x131x1): Measurement grid: dx=15mm, dy=15mm

Zoom Scan (7x7x7)/Cube 0: Measurement grid: dx=5mm, dy=5mm, dz=5mm

Peak SAR (extrapolated) = 2.06 W/kg

SAR(1 g) = 1.33 mW/g; SAR(10 g) = 0.819 mW/g

Reference Value = 9.72 V/m

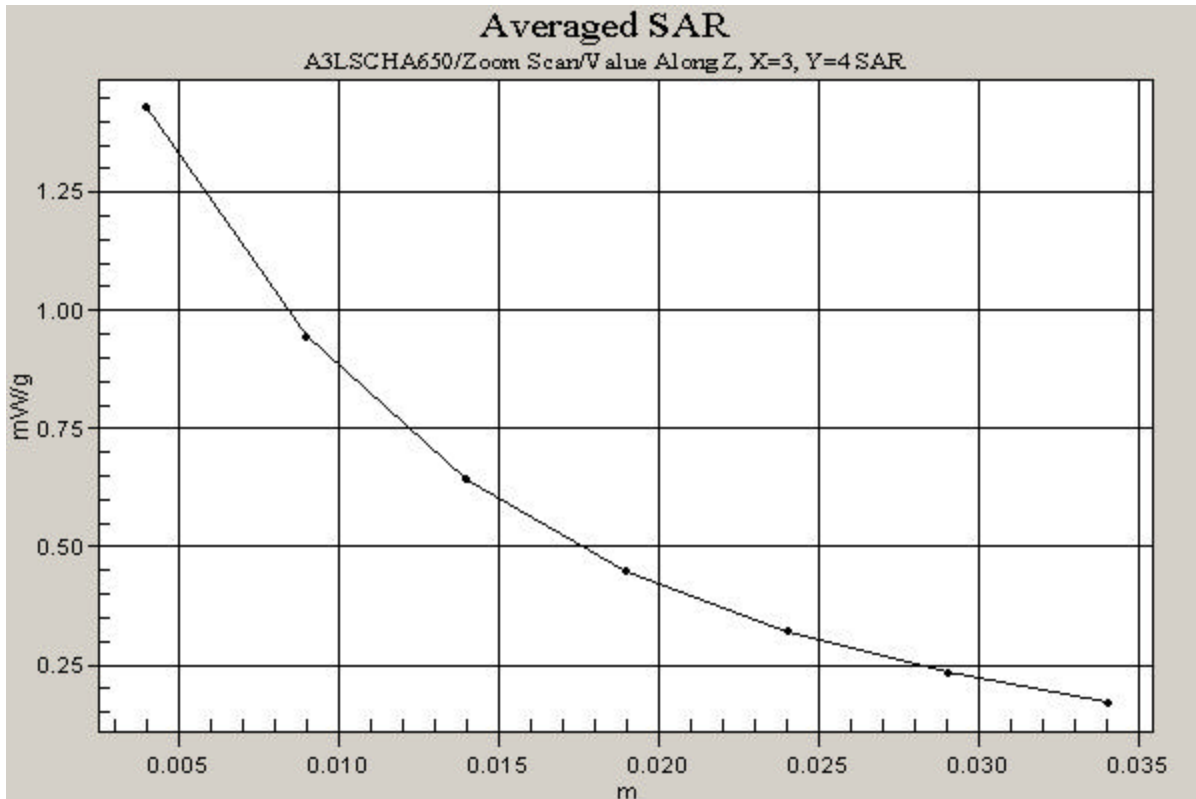

PCTEST ENGINEERING LABORATORY, INC.

DUT: SAMSUNG A3LSCHA650; Type: Tri Mode Phone; Serial: FA-018-J
Program: SCH-A650 AMPS Mode; Body

Communication System: AMPS; Frequency: 824.04 MHz; Duty Cycle: 1:1
Medium: 835 Muscle ($\sigma = 0.98$ mho/m, $\epsilon_r = 52.95$, $\rho = 1000$ kg/m³)
Phantom section: Flat Section

Test Date: 09-11-2003; Ambient Temp: 22.9°C; Tissue Temp: 20.5°C

Probe: ET3DV6 - SN1560; ConvF(6.6, 6.6, 6.6); Calibrated: 9/27/2002
Sensor-Surface: 4mm (Mechanical And Optical Surface Detection)
Electronics: DAE3 SN330; Calibrated: 12/1/2002
Phantom: SAM 12b; Type: SAM 4.0; Serial: TP:1197

Measurement SW: DASY4, V4.1 Build 47; Postprocessing SW: SEMCAD, V1.6 Build 115

Ch.0991, Ant Out, Standard Battery, w/ Beltclip, Space 1.8cm.

Area Scan (51x141x1): Measurement grid: dx=15mm, dy=15mm
Zoom Scan (7x7x7)/Cube 0: Measurement grid: dx=5mm, dy=5mm, dz=5mm
Peak SAR (extrapolated) = 1.48 W/kg
SAR(1 g) = 1.12 mW/g; SAR(10 g) = 0.788 mW/g
Reference Value = 32.2 V/m

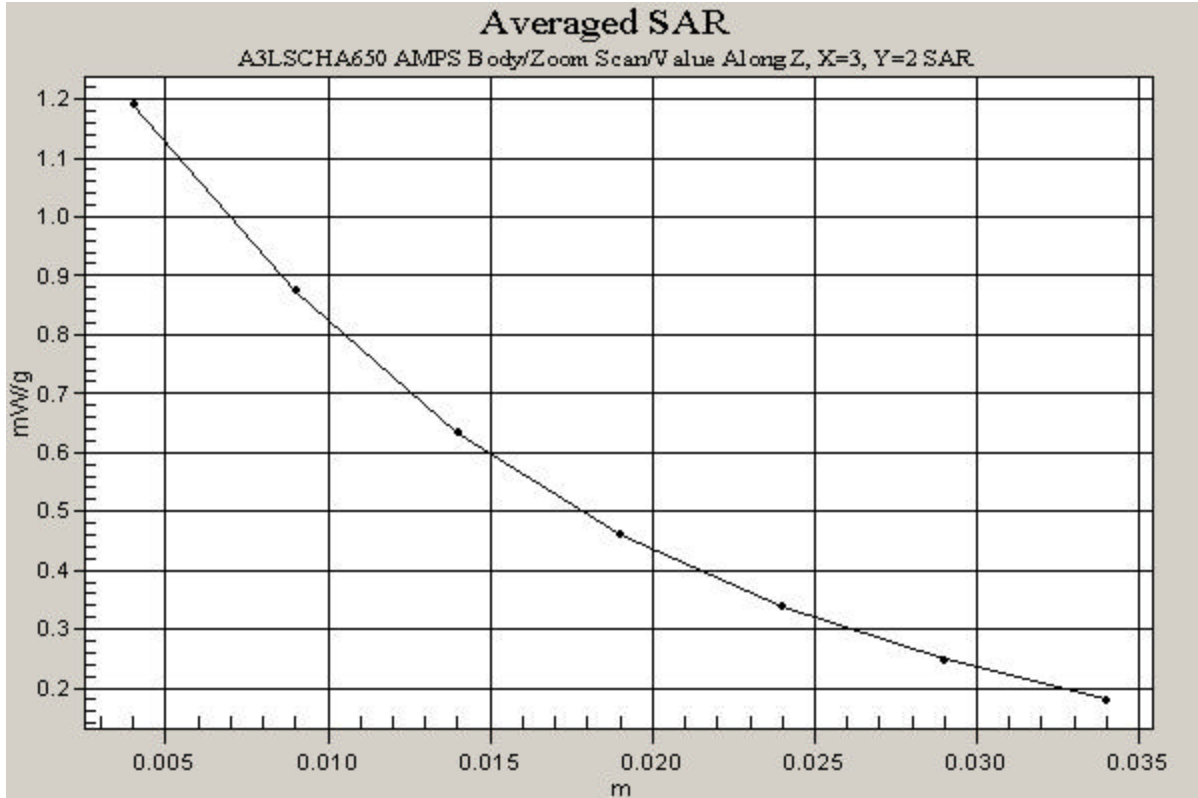

PCTEST ENGINEERING LABORATORY, INC.

DUT: SAMSUNG A3LSCHA650; Type: Tri Mode Phone; S/N: FA-018-J
Program: SCH-A650 PCS Mode

Communication System: PCS CDMA; Frequency: 1851.25 MHz; Duty Cycle: 1:1
Medium: 1900 Brain ($\sigma = 1.37$ mho/m, $\epsilon = 39.34$, $\rho = 1000$ kg/m³)
Phantom section: Left Section

Test Date: 09-08-2003; Ambient Temp: 22.7°C; Tissue Temp: 20.1°C

Probe: ET3DV6 - SN1560; ConvF(5.4, 5.4, 5.4); Calibrated: 9/27/2002
Sensor-Surface: 4mm (Mechanical And Optical Surface Detection)
Electronics: DAE3 SN330; Calibrated: 12/1/2002
Phantom: SAM 12b; Type: SAM 4.0; Serial: TP:1197

Measurement SW: DASY4, V4.1 Build 47; Postprocessing SW: SEMCAD, V1.6 Build 115

Ch.0025, Touch, Ant.In, Standard Battery

Area Scan (51x121x1): Measurement grid: dx=15mm, dy=15mm

Zoom Scan (7x7x7)/Cube 0: Measurement grid: dx=5mm, dy=5mm, dz=5mm

Peak SAR (extrapolated) = 1.86 W/kg

SAR(1 g) = 0.971 mW/g; SAR(10 g) = 0.484 mW/g

Reference Value = 5.87 V/m

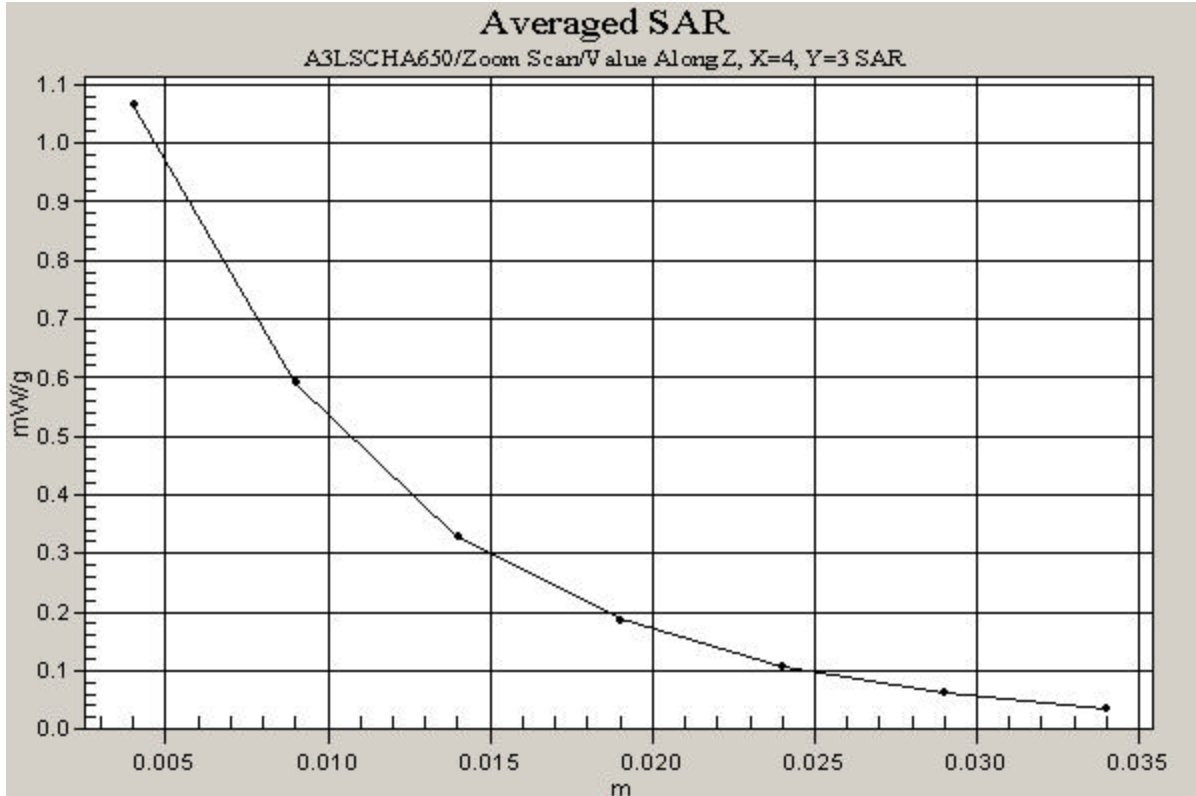

PCTEST ENGINEERING LABORATORY, INC.

DUT: SAMSUNG A3LSCHA650; Type: Tri Mode Phone; S/N: FA-018-J
Program: SCH-A650 PCS Mode; Body

Communication System: PCS CDMA; Frequency: 1851.25 MHz; Duty Cycle: 1:1
Medium: 1900 Muscle ($\sigma = 1.57$ mho/m, $\epsilon_r = 51.02$, $\rho = 1000$ kg/m³)
Phantom section: Flat Section

Test Date: 09-12-2003; Ambient Temp: 22.7°C; Tissue Temp: 20.4°C

Probe: ET3DV6 - SN1560; ConvF(4.9, 4.9, 4.9); Calibrated: 9/27/2002
Sensor-Surface: 4mm (Mechanical And Optical Surface Detection)
Electronics: DAE3 SN330; Calibrated: 12/1/2002
Phantom: SAM 12b; Type: SAM 4.0; Serial: TP:1197

Measurement SW: DASY4, V4.1 Build 47; Postprocessing SW: SEMCAD, V1.6 Build 115

Ch.0025, Ant Out, Standard Battery, w/ Beltclip, Space 1.8cm.

Area Scan (51x141x1): Measurement grid: dx=15mm, dy=15mm
Zoom Scan (7x7x7)/Cube 0: Measurement grid: dx=5mm, dy=5mm, dz=5mm
Peak SAR (extrapolated) = 0.715 W/kg
SAR(1 g) = 0.426 mW/g; SAR(10 g) = 0.247 mW/g
Reference Value = 11.6 V/m

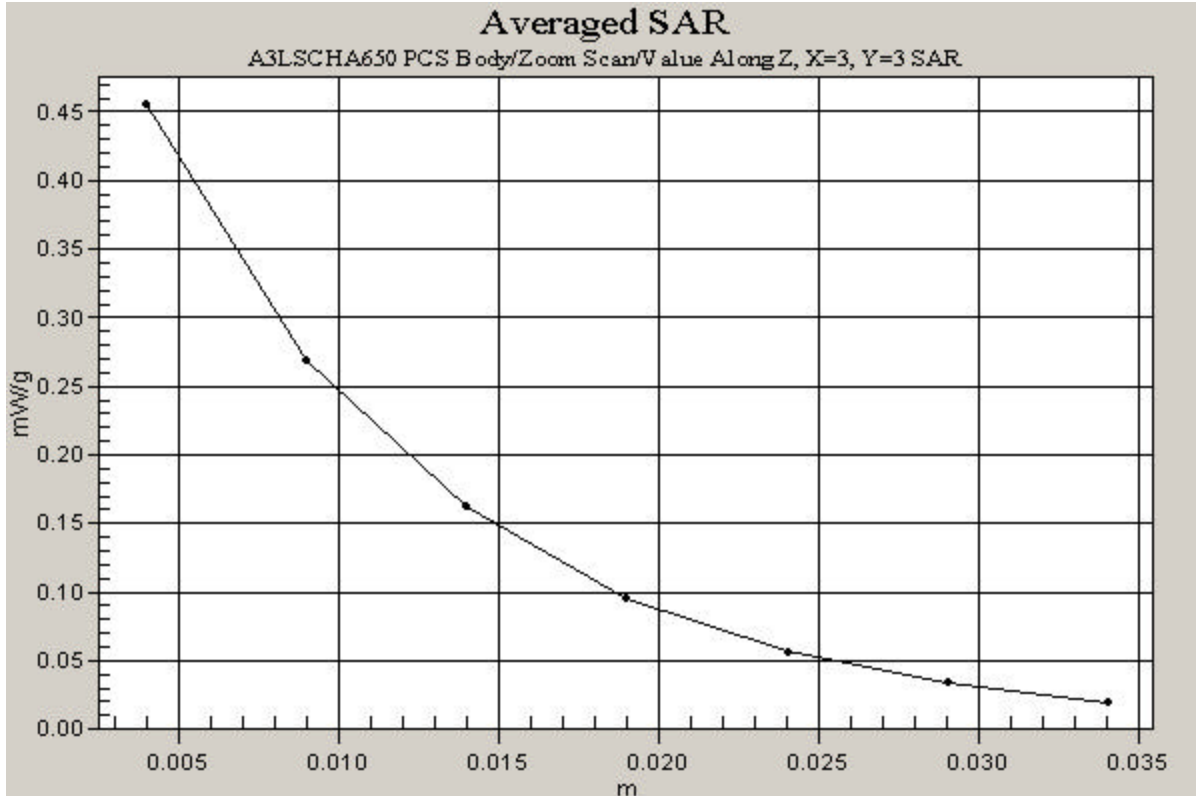

APPENDIX B: DIPOLE VALIDATION

PCTEST ENGINEERING LABORATORY, INC.

DUT: Dipole 835MHz; Type: D835V2; SN:406
Program: 835MHz. Dipole Validation - 1560

Communication System: CW; Frequency: 835 MHz; Duty Cycle: 1:1
Medium: 835MHz. Brain ($\sigma = 0.89$ mho/m, $\epsilon_r = 41.48$, $\rho = 1000$ kg/m³)
Phantom section: Flat Section

Test Date: 09-10-2003; Ambient Temp: 22.5°C; Tissue Temp: 20.6°C

Probe: ET3DV6 - SN1560; ConvF(6.9, 6.9, 6.9); Calibrated: 9/27/2002
Sensor-Surface: 4mm (Mechanical And Optical Surface Detection)
Electronics: DAE3 SN330; Calibrated: 12/1/2002
Phantom: SAM 12b; Type: SAM 4.0; Serial: TP:1197

Measurement SW: DASY4, V4.1 Build 47; Postprocessing SW: SEMCAD, V1.6 Build 115

835MHz. Dipole Validation - 1560

Area Scan (61x61x1): Measurement grid: dx=15mm, dy=15mm
Zoom Scan (7x7x7)/Cube 0: Measurement grid: dx=5mm, dy=5mm, dz=5mm
Peak SAR (extrapolated) = 3.65 W/kg
SAR(1 g) = 2.38 mW/g; SAR(10 g) = 1.58 mW/g
Reference Value = 59.34 V/m

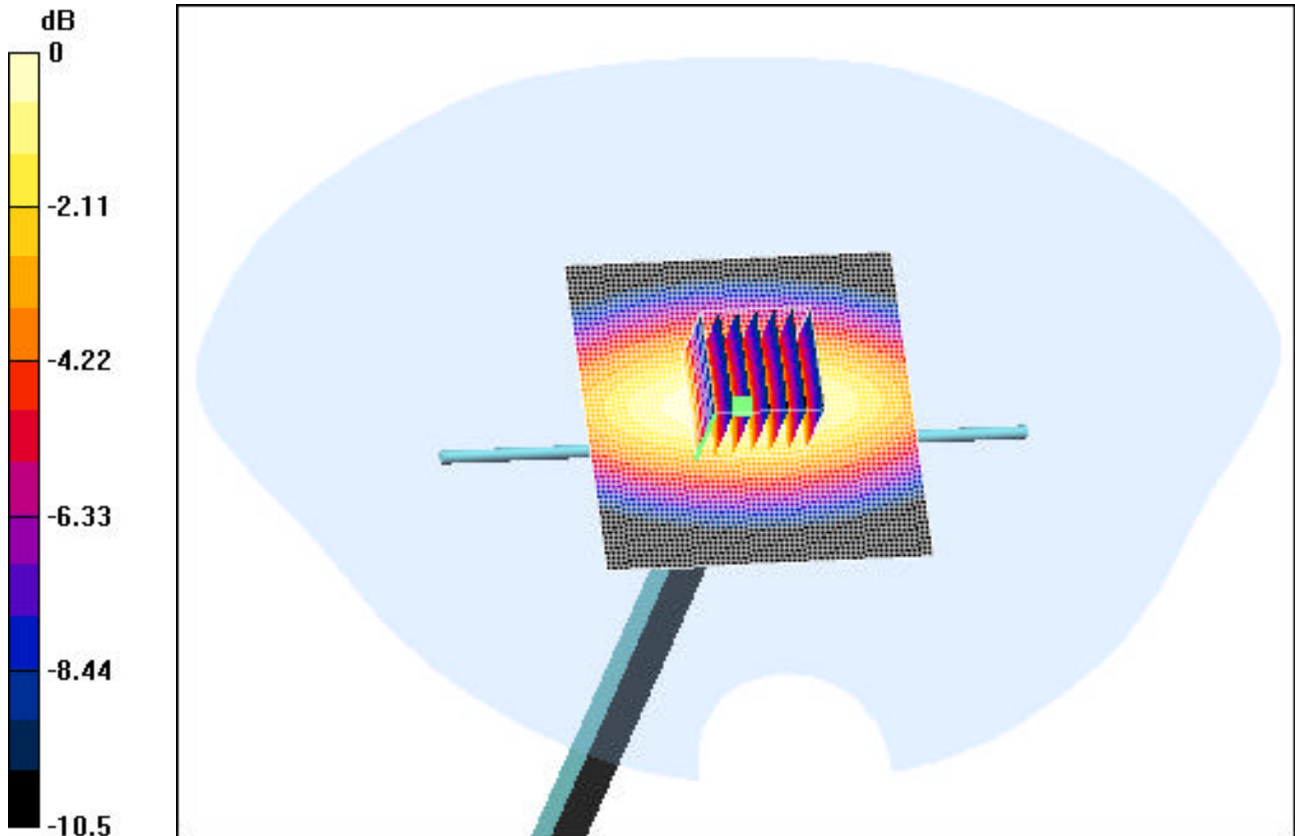

PCTEST ENGINEERING LABORATORY, INC.

DUT: Dipole 835MHz; Type: D835V2; SN:406
Program: 835MHz. Dipole Validation - 1560

Communication System: CW; Frequency: 835 MHz; Duty Cycle: 1:1
Medium: 835MHz. Brain ($\sigma = 0.89$ mho/m, $\epsilon_r = 41.48$, $\rho = 1000$ kg/m³)
Phantom section: Flat Section

Test Date: 09-11-2003; Ambient Temp: 22.5°C; Tissue Temp: 20.6°C

Probe: ET3DV6 - SN1560; ConvF(6.9, 6.9, 6.9); Calibrated: 9/27/2002
Sensor-Surface: 4mm (Mechanical And Optical Surface Detection)
Electronics: DAE3 SN330; Calibrated: 12/1/2002
Phantom: SAM 12b; Type: SAM 4.0; Serial: TP:1197

Measurement SW: DASY4, V4.1 Build 47; Postprocessing SW: SEMCAD, V1.6 Build 115

835MHz. Dipole Validation - 1560

Area Scan (61x61x1): Measurement grid: dx=15mm, dy=15mm
Zoom Scan (7x7x7)/Cube 0: Measurement grid: dx=5mm, dy=5mm, dz=5mm
Peak SAR (extrapolated) = 3.65 W/kg
SAR(1 g) = 2.38 mW/g; SAR(10 g) = 1.58 mW/g
Reference Value = 59.34 V/m

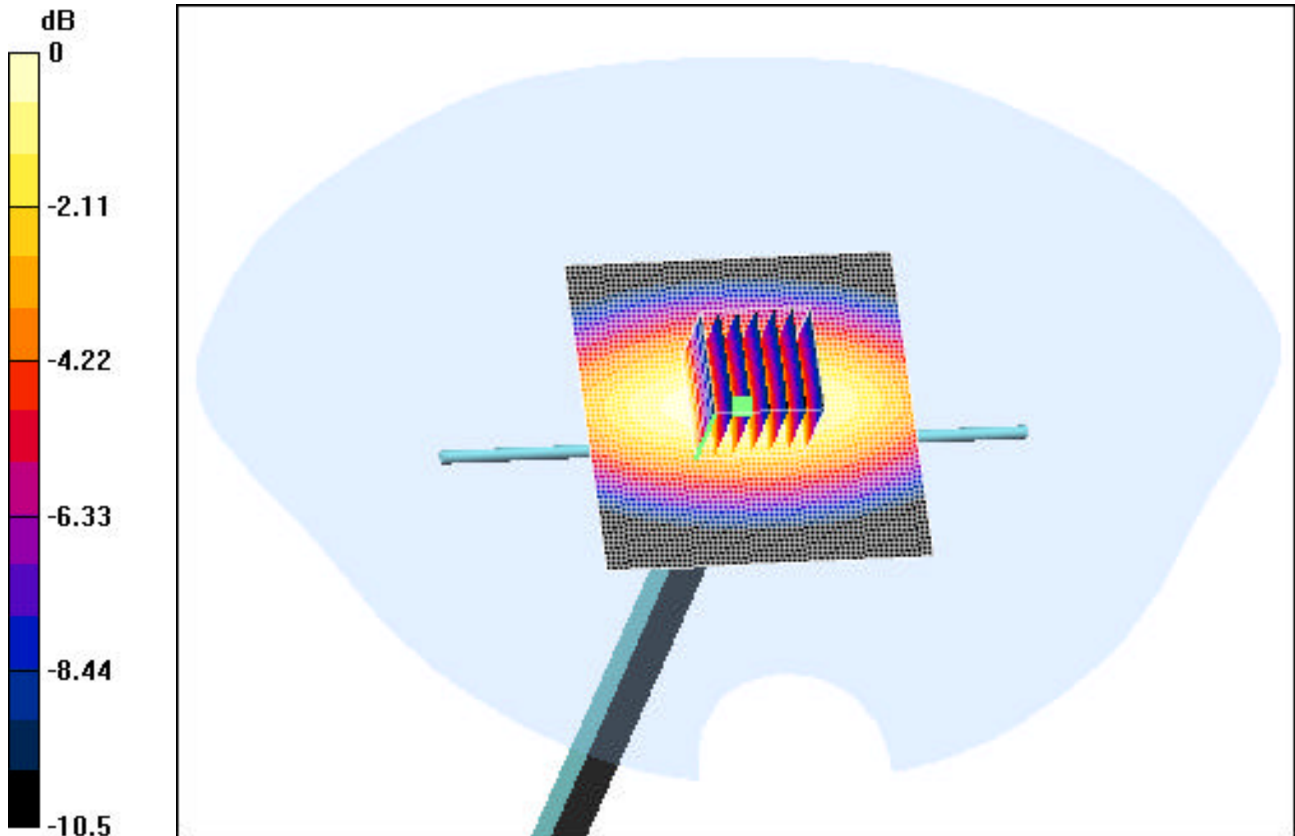

PCTEST ENGINEERING LABORATORY, INC.

DUT: Dipole 1900 MHz; Type: D1900V2; SN:502
Program: 1900MHz Dipole Validation - 1560

Communication System: CW; Frequency: 1900 MHz; Duty Cycle: 1:1
Medium: 1900MHz. Brain ($\sigma = 1.37$ mho/m, $\epsilon_r = 39.94$, $\rho = 1000$ kg/m³)
Phantom section: Flat Section

Test Date: 09-08-2003; Ambient Temp: 22.7°C; Tissue Temp: 20.1°C

Probe: ET3DV6 - SN1560; ConvF(5.4, 5.4, 5.4); Calibrated: 9/27/2002
Sensor-Surface: 4mm (Mechanical And Optical Surface Detection)
Electronics: DAE3 SN330; Calibrated: 12/1/2002
Phantom: SAM 12b; Type: SAM 4.0; Serial: TP:1197

Measurement SW: DASY4, V4.1 Build 33; Postprocessing SW: SEMCAD, V1.6 Build 115

1900MHz Dipole Validation - 1560

Area Scan (61x61x1): Measurement grid: dx=15mm, dy=15mm
Zoom Scan (7x7x7)/Cube 0: Measurement grid: dx=5mm, dy=5mm, dz=5mm
Peak SAR (extrapolated) = 17.9 W/kg
SAR(1 g) = 3.92 mW/g; SAR(10 g) = 5.08 mW/g
Reference Value = 93.5 V/m

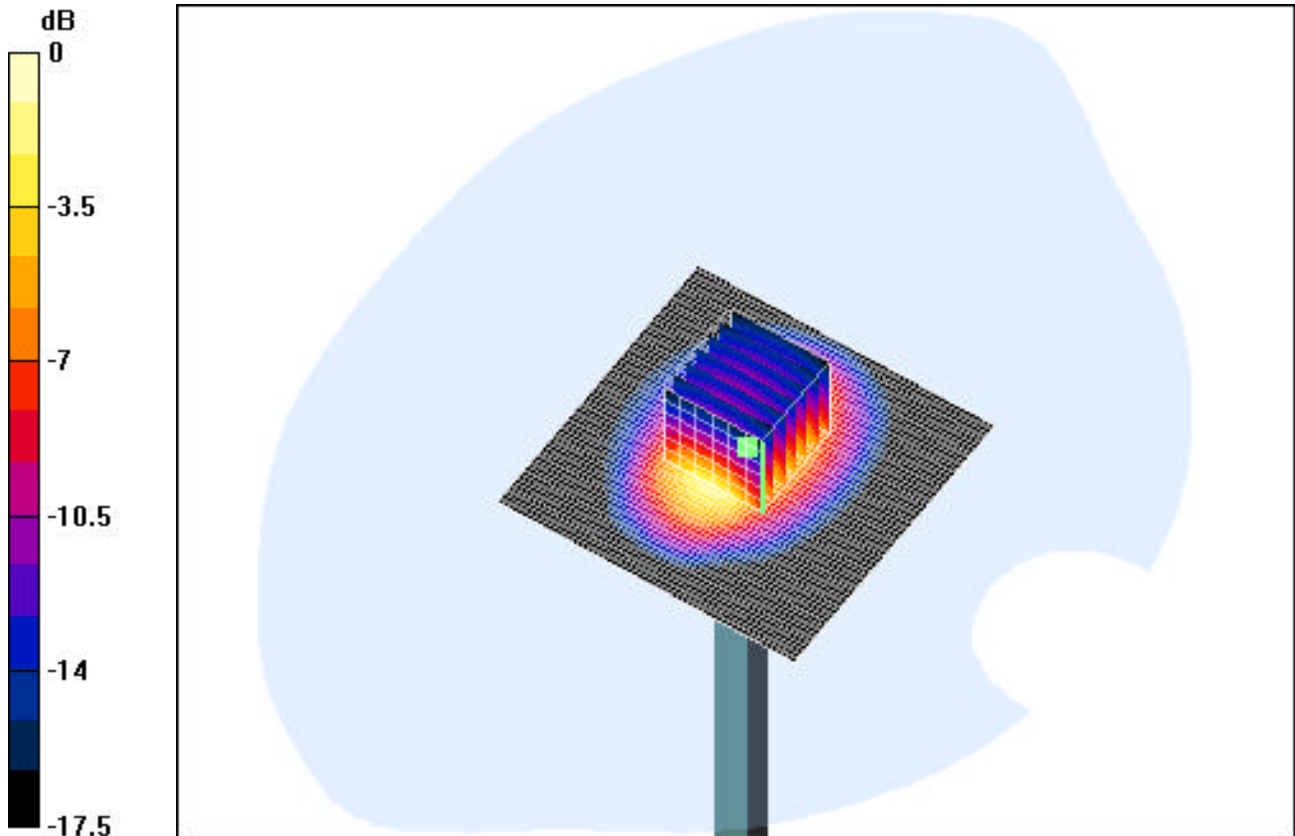

PCTEST ENGINEERING LABORATORY, INC.

DUT: Dipole 1900 MHz; Type: D1900V2; SN:502
Program: 1900MHz Dipole Validation - 1560

Communication System: CW; Frequency: 1900 MHz; Duty Cycle: 1:1
Medium: 1900MHz. Brain ($\sigma = 1.37$ mho/m, $\epsilon_r = 39.94$, $\rho = 1000$ kg/m³)
Phantom section: Flat Section

Test Date: 09-09-2003; Ambient Temp: 22.5°C; Tissue Temp: 20.6°C

Probe: ET3DV6 - SN1560; ConvF(5.4, 5.4, 5.4); Calibrated: 9/27/2002
Sensor-Surface: 4mm (Mechanical And Optical Surface Detection)
Electronics: DAE3 SN330; Calibrated: 12/1/2002
Phantom: SAM 12b; Type: SAM 4.0; Serial: TP:1197

Measurement SW: DASY4, V4.1 Build 33; Postprocessing SW: SEMCAD, V1.6 Build 115

1900MHz Dipole Validation - 1560

Area Scan (61x61x1): Measurement grid: dx=15mm, dy=15mm
Zoom Scan (7x7x7)/Cube 0: Measurement grid: dx=5mm, dy=5mm, dz=5mm
Peak SAR (extrapolated) = 17.9 W/kg
SAR(1 g) = 3.92 mW/g; SAR(10 g) = 5.08 mW/g
Reference Value = 93.5 V/m

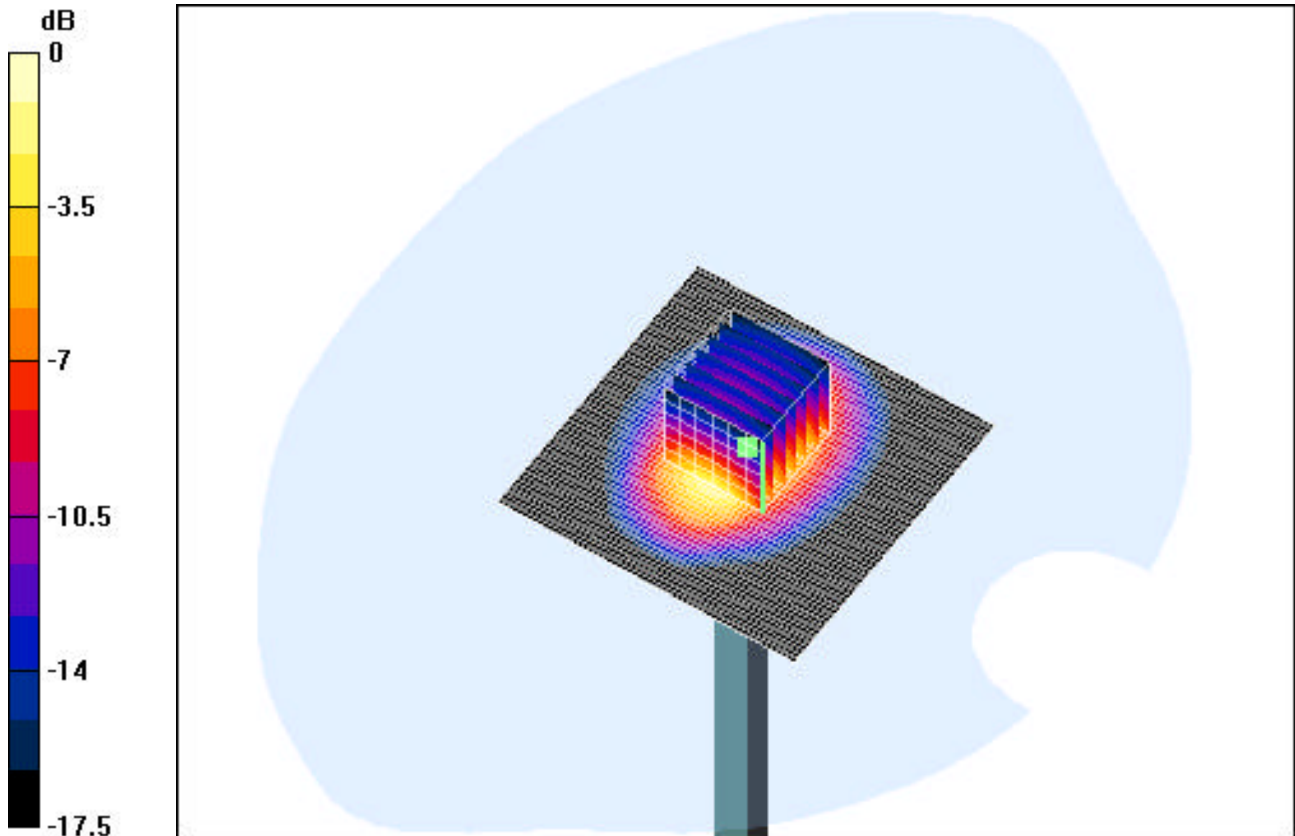

APPENDIX C: PROBE CALIBRATION

Schmid & Partner Engineering AG

Zeughausstrasse 43, 8004 Zurich, Switzerland, Phone +41 1 245 97 00, Fax +41 1 245 97 79

Calibration Certificate

Dosimetric E-Field Probe

Type:

ET3DV6

Serial Number:

1560

Place of Calibration:

Zurich

Date of Calibration:

September 27, 2002

Calibration Interval:

12 months

Schmid & Partner Engineering AG hereby certifies, that this device has been calibrated on the date indicated above. The calibration was performed in accordance with specifications and procedures of Schmid & Partner Engineering AG.

Wherever applicable, the standards used in the calibration process are traceable to international standards. In all other cases the standards of the Laboratory for EMF and Microwave Electronics at the Swiss Federal Institute of Technology (ETH) in Zurich, Switzerland have been applied.

Calibrated by:

N. Vetter

Approved by:

Alvin Kofler

Probe ET3DV6

SN:1560

Manufactured:	December 1, 2000
Last calibration:	February 20, 2001
Recalibrated:	September 27, 2002

Calibrated for DASY Systems

(Note: non-compatible with DASY2 system!)

DASY - Parameters of Probe: ET3DV6 SN:1560

Sensitivity in Free Space

NormX	1.48 $\mu\text{V}/(\text{V}/\text{m})^2$
NormY	1.50 $\mu\text{V}/(\text{V}/\text{m})^2$
NormZ	1.42 $\mu\text{V}/(\text{V}/\text{m})^2$

Diode Compression

DCP X	93	mV
DCP Y	93	mV
DCP Z	93	mV

Sensitivity in Tissue Simulating Liquid

Head	835 MHz	$\epsilon_r = 41.5 \pm 5\%$	$\sigma = 0.90 \pm 5\%$ mho/m
Head	900 MHz	$\epsilon_r = 41.5 \pm 5\%$	$\sigma = 0.97 \pm 5\%$ mho/m
	ConvF X	6.9 $\pm 9.5\%$ (k=2)	Boundary effect:
	ConvF Y	6.9 $\pm 9.5\%$ (k=2)	Alpha 0.60
	ConvF Z	6.9 $\pm 9.5\%$ (k=2)	Depth 1.69
Head	1900 MHz	$\epsilon_r = 40.0 \pm 5\%$	$\sigma = 1.40 \pm 5\%$ mho/m
Head	1800 MHz	$\epsilon_r = 40.0 \pm 5\%$	$\sigma = 1.40 \pm 5\%$ mho/m
	ConvF X	5.4 $\pm 9.5\%$ (k=2)	Boundary effect:
	ConvF Y	5.4 $\pm 9.5\%$ (k=2)	Alpha 0.49
	ConvF Z	5.4 $\pm 9.5\%$ (k=2)	Depth 2.36

Boundary Effect

Head	835 MHz	Typical SAR gradient: 5 % per mm	
	Probe Tip to Boundary	1 mm	2 mm
	SAR _{be} [%] Without Correction Algorithm	7.3	3.7
	SAR _{be} [%] With Correction Algorithm	0.0	0.2
Head	1900 MHz	Typical SAR gradient: 10 % per mm	
	Probe Tip to Boundary	1 mm	2 mm
	SAR _{be} [%] Without Correction Algorithm	11.1	7.6
	SAR _{be} [%] With Correction Algorithm	0.2	0.4

Sensor Offset

Probe Tip to Sensor Center	2.7	mm
Optical Surface Detection	1.3 \pm 0.2	mm

Receiving Pattern (ϕ), $\theta = 0^\circ$

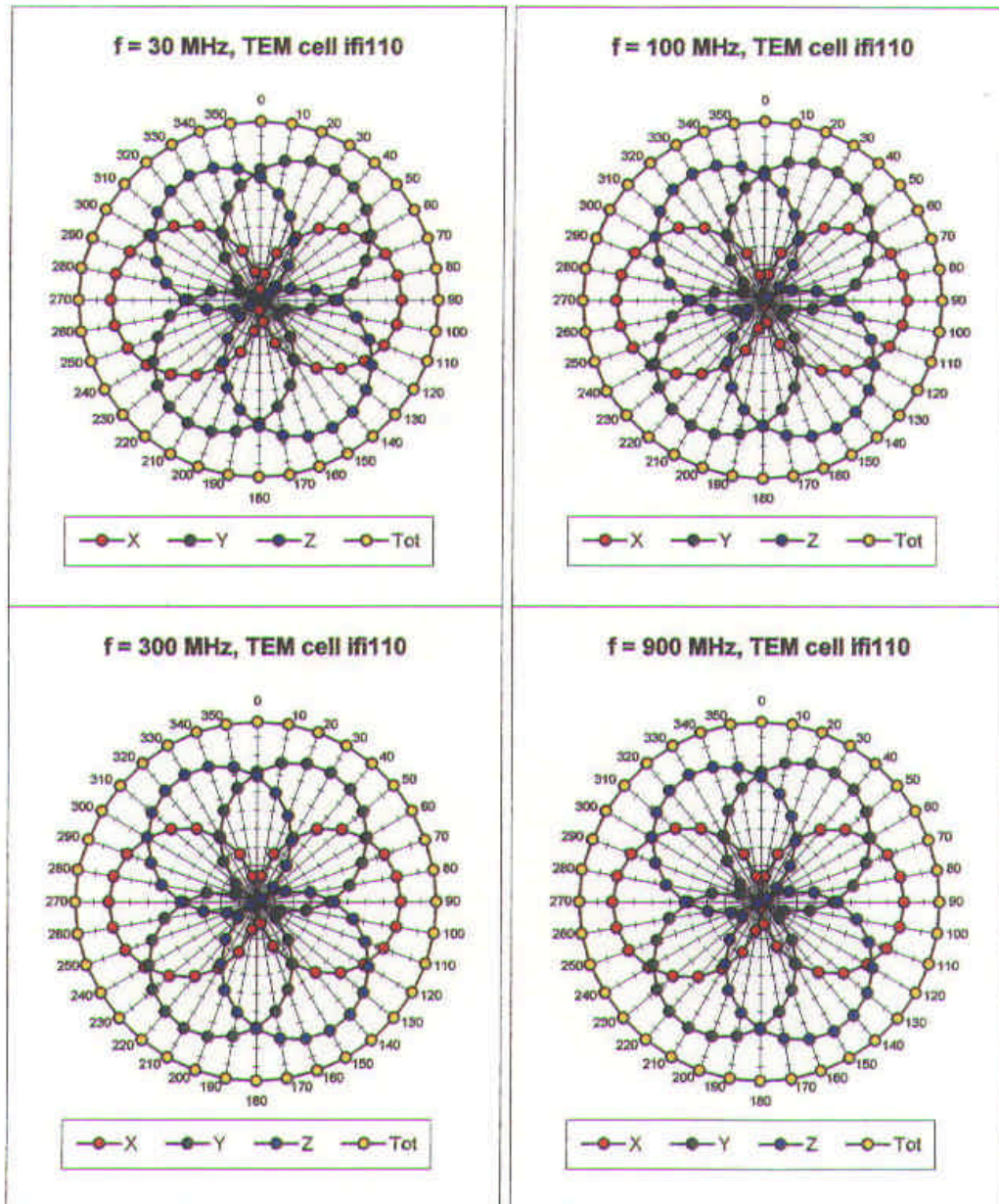

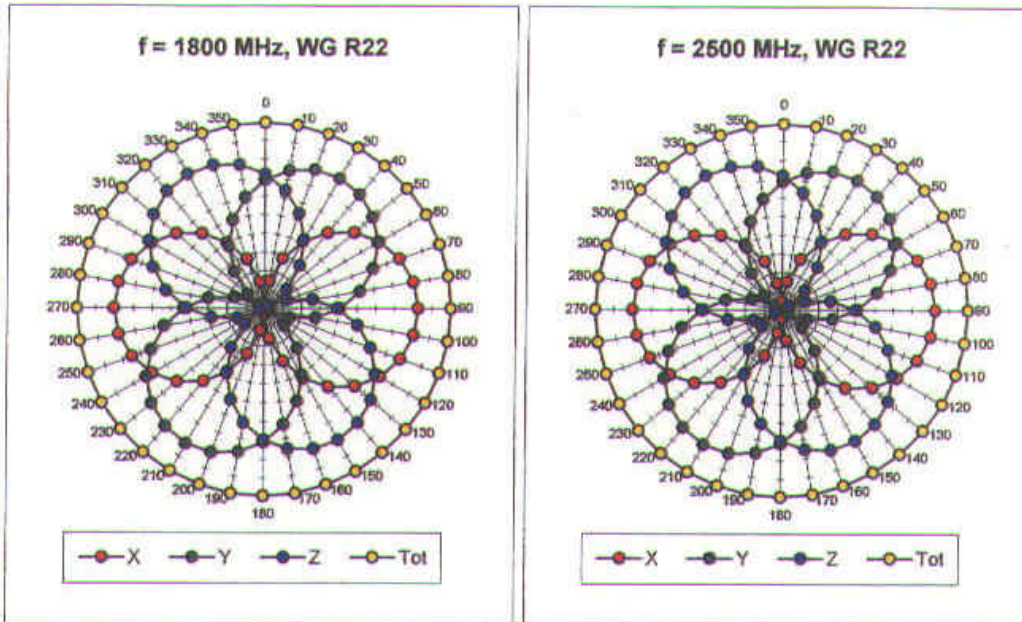

Isotropy Error (ϕ), $\theta = 0^\circ$

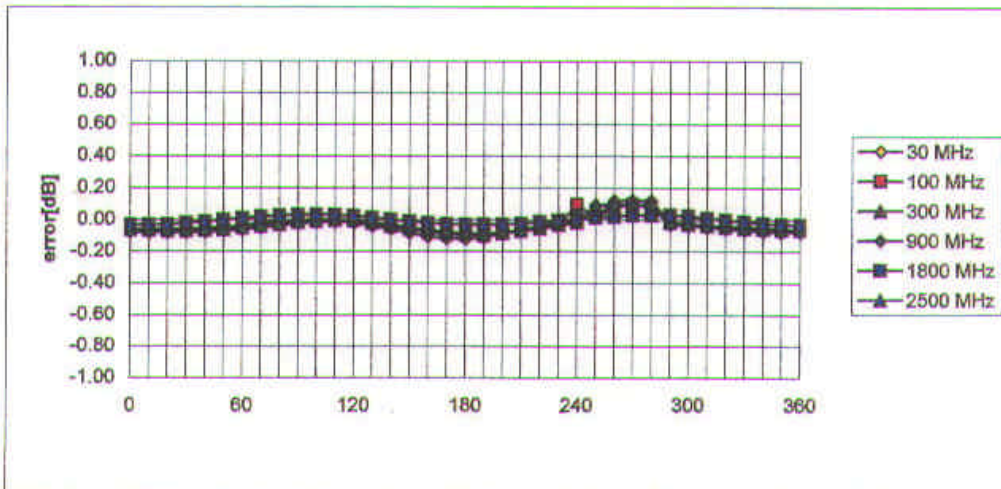

Frequency Response of E-Field

(TEM-Cell:ifi110, Waveguide R22)

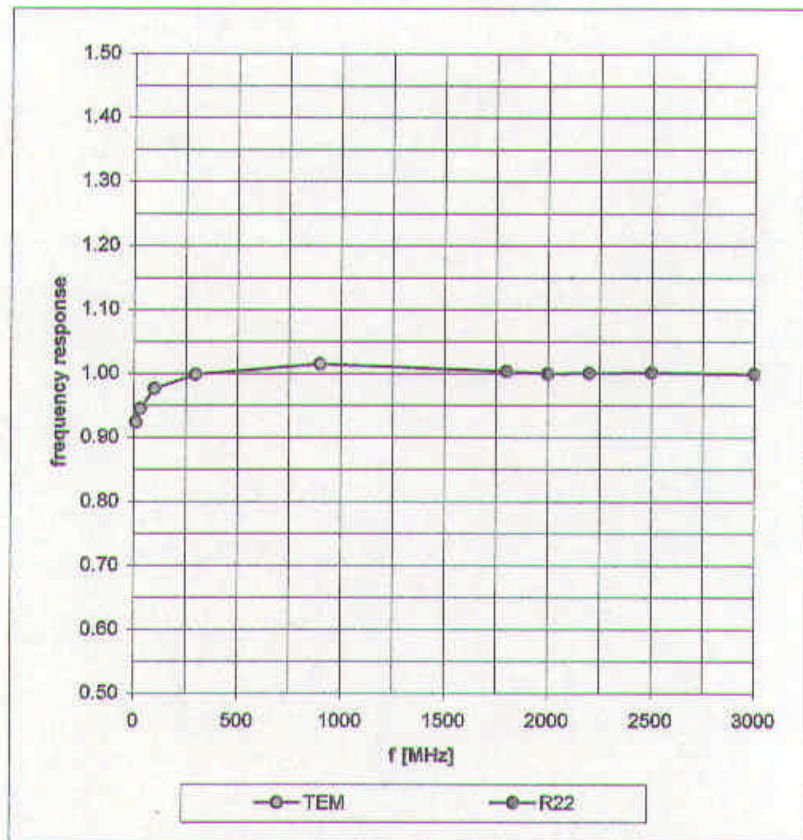

Dynamic Range $f(\text{SAR}_{\text{brain}})$ (Waveguide R22)

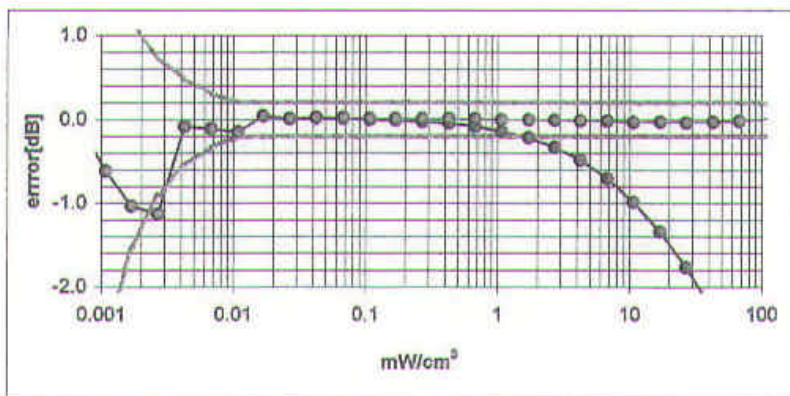
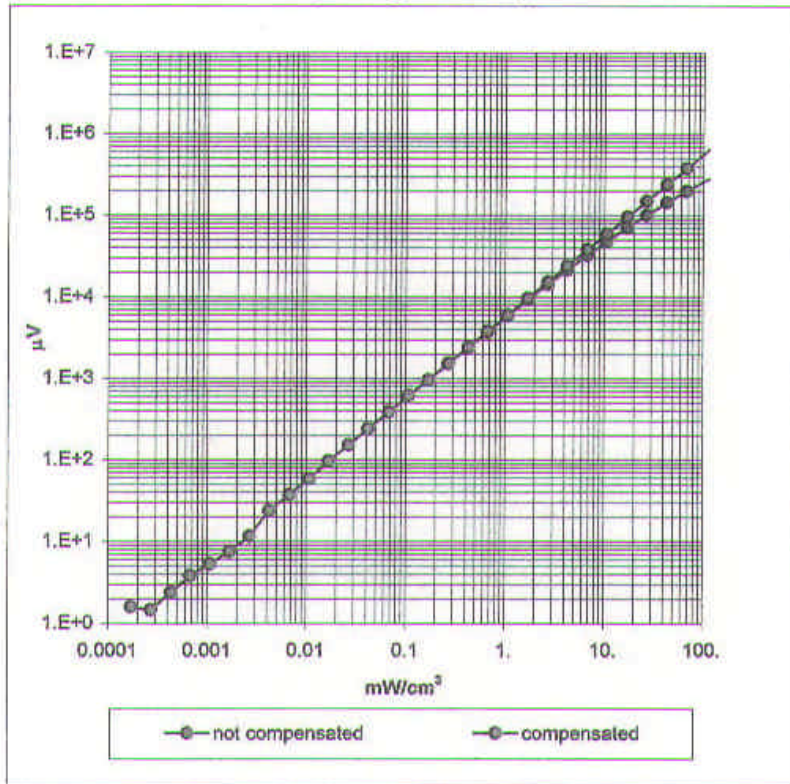

Conversion Factor Assessment

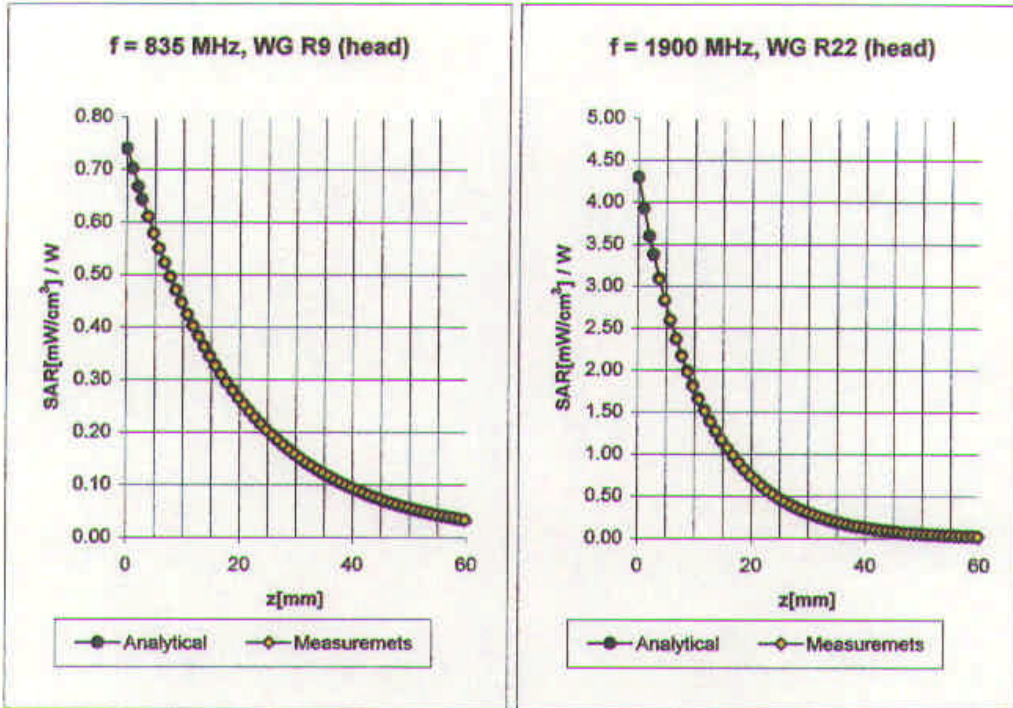

Head	835 MHz	$\epsilon_r = 41.5 \pm 5\%$	$\sigma = 0.90 \pm 5\%$ mho/m	
Head	900 MHz	$\epsilon_r = 41.5 \pm 5\%$	$\sigma = 0.97 \pm 5\%$ mho/m	
	ConvF X	$6.9 \pm 9.5\%$ (k=2)	Boundary effect:	
	ConvF Y	$6.9 \pm 9.5\%$ (k=2)	Alpha	0.60
	ConvF Z	$6.9 \pm 9.5\%$ (k=2)	Depth	1.69
Head	1900 MHz	$\epsilon_r = 40.0 \pm 5\%$	$\sigma = 1.40 \pm 5\%$ mho/m	
Head	1800 MHz	$\epsilon_r = 40.0 \pm 5\%$	$\sigma = 1.40 \pm 5\%$ mho/m	
	ConvF X	$5.4 \pm 9.5\%$ (k=2)	Boundary effect:	
	ConvF Y	$5.4 \pm 9.5\%$ (k=2)	Alpha	0.49
	ConvF Z	$5.4 \pm 9.5\%$ (k=2)	Depth	2.36

Conversion Factor Assessment

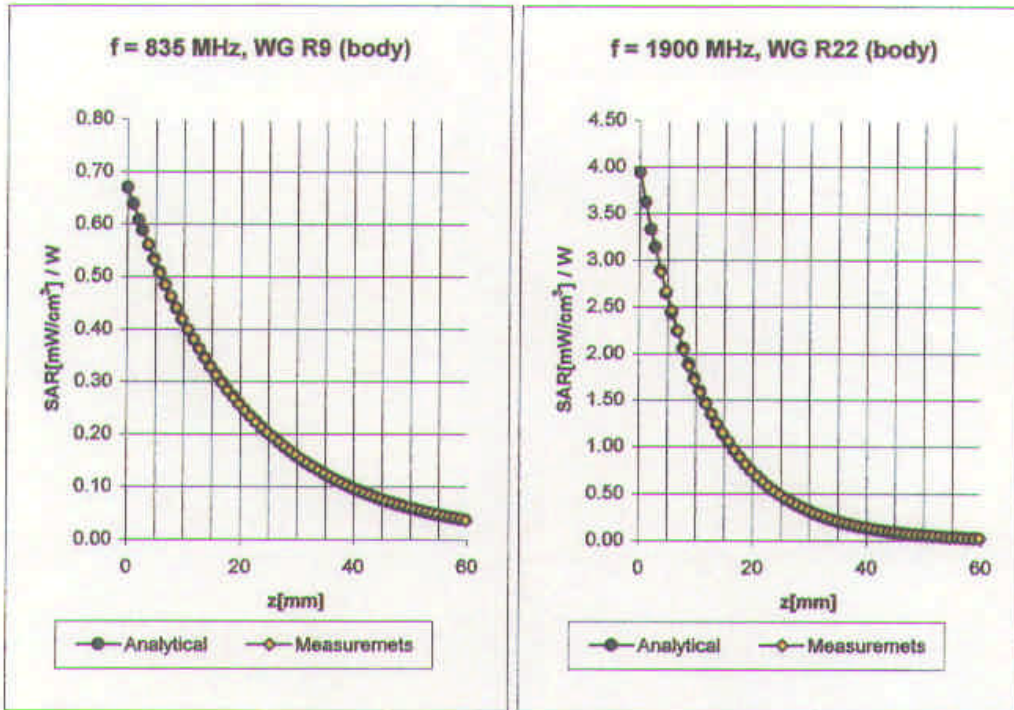

Body	835 MHz	$\epsilon_r = 55.2 \pm 5\%$	$\sigma = 0.97 \pm 5\%$ mho/m	
Body	900 MHz	$\epsilon_r = 55.0 \pm 5\%$	$\sigma = 1.05 \pm 5\%$ mho/m	
	ConvF X	$6.6 \pm 9.5\%$ (k=2)	Boundary effect:	
	ConvF Y	$6.6 \pm 9.5\%$ (k=2)	Alpha	0.33
	ConvF Z	$6.6 \pm 9.5\%$ (k=2)	Depth	2.60
Body	1900 MHz	$\epsilon_r = 53.3 \pm 5\%$	$\sigma = 1.52 \pm 5\%$ mho/m	
Body	1800 MHz	$\epsilon_r = 53.3 \pm 5\%$	$\sigma = 1.52 \pm 5\%$ mho/m	
	ConvF X	$4.9 \pm 9.5\%$ (k=2)	Boundary effect:	
	ConvF Y	$4.9 \pm 9.5\%$ (k=2)	Alpha	0.64
	ConvF Z	$4.9 \pm 9.5\%$ (k=2)	Depth	2.24

Conversion Factor Assessment

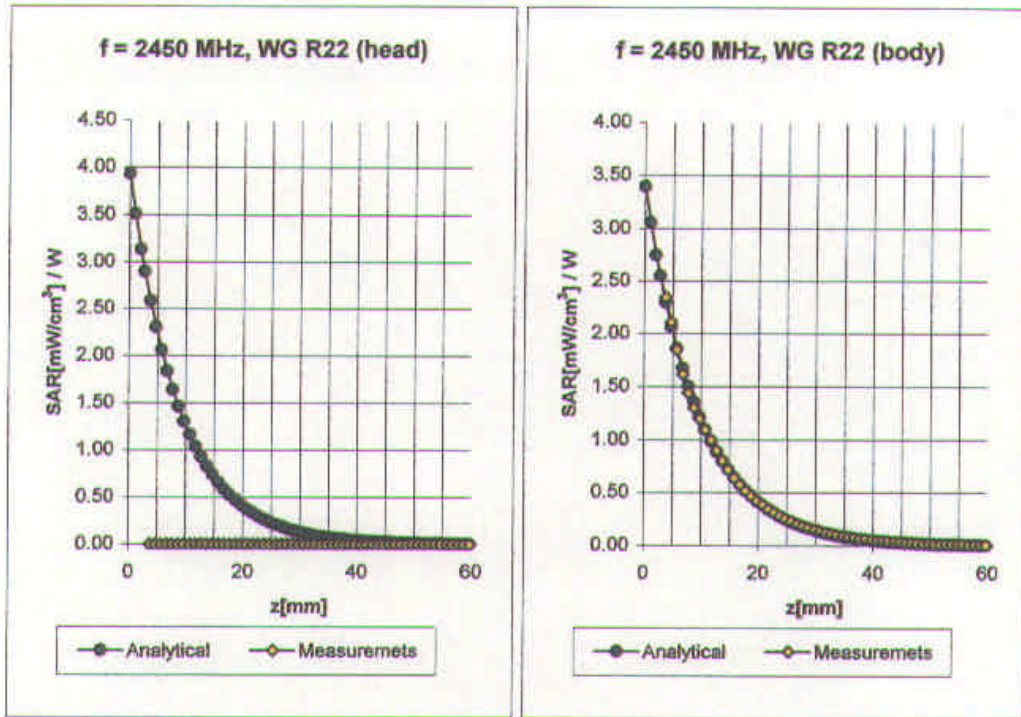

2450	Head	MHz	$\epsilon_r = 39.2 \pm 5\%$	$\sigma = 1.80 \pm 5\%$ mho/m
	ConvF X	4.9 \pm 8.9% (k=2)		Boundary effect:
	ConvF Y	4.9 \pm 8.9% (k=2)		Alpha 1.00
	ConvF Z	4.9 \pm 8.9% (k=2)		Depth 1.60
2450	Body	MHz	$\epsilon_r = 62.7 \pm 5\%$	$\sigma = 1.95 \pm 5\%$ mho/m
	ConvF X	4.4 \pm 8.9% (k=2)		Boundary effect:
	ConvF Y	4.4 \pm 8.9% (k=2)		Alpha 1.00
	ConvF Z	4.4 \pm 8.9% (k=2)		Depth 1.50

Deviation from Isotropy in HSL

Error (θ, ϕ), $f = 900$ MHz

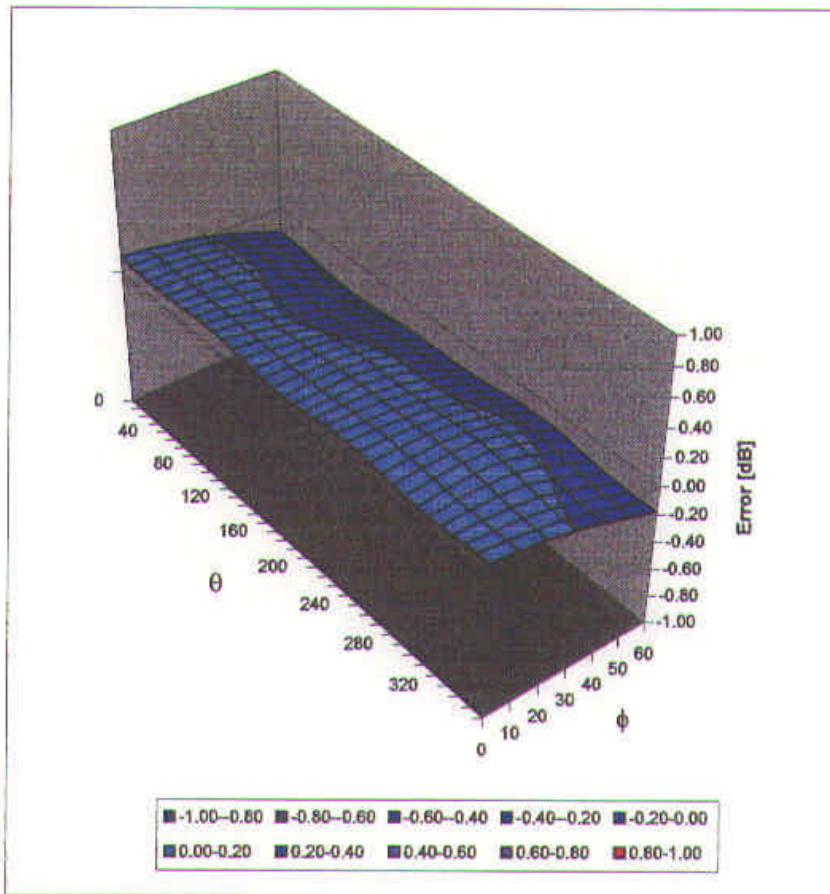

Additional Conversion Factors for Dosimetric E-Field Probe

Type:

ET3DV6

Serial Number:

1560

Place of Assessment:

Zurich

Date of Assessment:

September 30, 2002

Probe Calibration Date:

September 27, 2002

Schmid & Partner Engineering AG hereby certifies that conversion factor(s) of this probe have been evaluated on the date indicated above. The assessment was performed using the FDTD numerical code SEMCAD of Schmid & Partner Engineering AG. Since the evaluation is coupled with measured conversion factors, it has to be recalculated yearly, i.e., following the re-calibration schedule of the probe. The uncertainty of the numerical assessment is based on the extrapolation from measured value at 900 MHz or at 1800 MHz.

Assessed by:

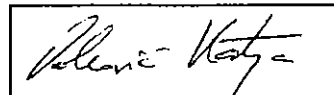

Dosimetric E-Field Probe ET3DV6 SN: 1560

Conversion factor (\pm standard deviation)

150 MHz	ConvF	8.6 \pm 8%	$\epsilon_r = 52.3 \pm 5\%$ $s = 0.76 \pm 5\%$ mho/m (Head tissue)
150 MHz	ConvF	8.5 \pm 8%	$\epsilon_r = 61.9 \pm 5\%$ $s = 0.80 \pm 5\%$ mho/m (Body tissue)
300 MHz	ConvF	7.4 \pm 8%	$\epsilon_r = 45.3 \pm 5\%$ $s = 0.87 \pm 5\%$ mho/m (Head tissue)
450 MHz	ConvF	7.9 \pm 8%	$\epsilon_r = 45.1 \pm 5\%$ $s = 0.85 \pm 5\%$ mho/m (Head tissue)
450 MHz	ConvF	7.7 \pm 8%	$\epsilon_r = 56.7 \pm 5\%$ $s = 0.94 \pm 5\%$ mho/m (Body tissue)