

Retractable bottom helical Antenna

Vendor : Allgon Mobile commucations AB

Vendor P/N : 39445.1

Electrical Data

Freq. Band

Transmit Band (Tx) : 824 - 849 / 1851.25 - 1908.75 MHz

Receive Band (Rx) : 869 - 894 / 1931.25 - 1988.75 MHz

Impedance

Nominal Value : 50 Ω

VSWR (Free Space)

	Maximum Values	
	Tx	Rx
extended	2:1	2:1
retracted	3.2:1	3.2:1

GAIN

Typical Minimum Values in Maximum Direction

	Tx	Rx
extended	-2dBd	-2dBd
retracted	-3.5dBd	-3.5dBd

± 0 dBd : dB relative to a dipole

Maximum Lobe Tilt

	Tx	Rx
extended	45 $^{\circ}$	45 $^{\circ}$
retracted	45 $^{\circ}$	45 $^{\circ}$

Power Rating

Maximum Value P = 2W (continuous wave)

Environment

Operational Temperature

Low Operational Temperature T_{LO} : -20°C

High Operational Temperature T_{HO} : +70°C

Method : The antenna is placed in a climatic chamber at T_{LO} (or T_{HO})
The antenna is taken out after 1 hour, and the VSWR is immediately measured.

Temperature Cycling

Low Temperature Cycling T_{LC} : -40°C

High Temperature Cycling T_{HC} : +80°C

Method : The antenna is placed in a climatic chamber. The temperature is cycled as follows:
The temperature is kept constantly at T_{LC} for 1 hour, increased to T_{HC} during 1 hour, kept constantly at T_{HC} for 1 hour, and then decreased to T_{LC} during 1 hour. This procedure is repeated 10 times, ending at room temperature.

Humidity

Relative Humidity : 95%

Temperature : +55°C

Method : The antenna is placed in a climatic chamber for 24 hours.
The antenna is taken out from the chamber and measured after another 24 hours in room temperature.

Sinusoidal Vibration

Vibration Freq. : 8-25-8 Hz (1 cycle)

Sweep Rate : 1 octave/min (logarithmic)

Maximum Amplitude : $A = 1.5$ mm

Maximum Acceleration : 2g

Crossover Freq. : 18.2Hz

Method : The extended antenna is assembled in the test equipment.
The vibration is done both x- and z- directions, with a duration of 1 hour in each direction.

PRODUCT SPECIFICATION DRAWING 39445101G . Version 3

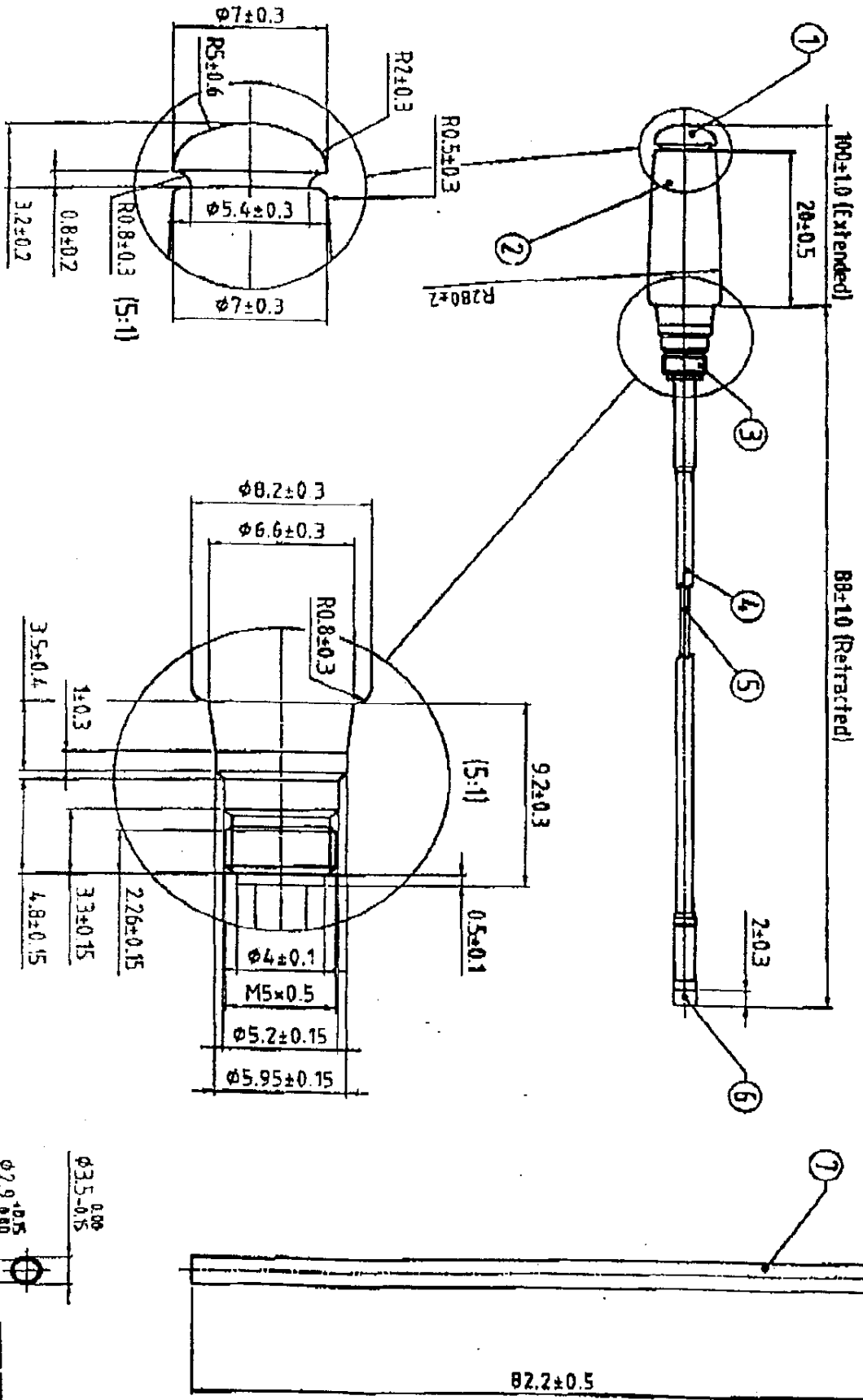

NO.	MATERIAL	SURFACE TREATMENT
1	Plastic Zyrel 66 E101 L	Surface acc. to Charities VDI 3400 no. 30. Colour according to NCS 9500
2	Plastic Saniprene 103-40	Surface acc. to Charities VDI 3400 no. 33. Colour according to NCS 8500
3	Brass SS 5170-04	Cu/CuNi2-4b acc. to SS ISO 1458
4	Plastic PVC	
5	Ni-Ti-Cr Super elastic alloy	
6	Brass SS 5170-04	Cu/CuNi2-4b acc. to SS ISO 1458

Scale
2:1

Drawn
98-02-24 HAS

ALLGOM MOBILE
COMMUNICATIONS AB
SWEDEN



This document and its contents are the property of ALLGOM MOBILE COMMUNICATIONS AB, SWEDEN and must not be copied, reproduced, borrowed or disclosed to any third party without the consent of its Corporation or its personnel.