

NAM features can be programmed as follows:

Notes:

- If you enter the NAM program mode, each item shows the currently stored data. Go to the next item by pressing **OK**.
- You can modify the data by entering a new data.
- If you enter a wrong digit, press **CLR** to delete the last digit. Press and hold **CLR** to delete all digits.
- To scroll items backwards or forwards, press the **VOLUME** button on the left side of the phone or **NAVI_UP/DOWN** key.

Setting Up NAM1

LCD Display	Key in	Function
SVC Menu 1.Basic 2.General 3.NAM1 4.NAM2	1	-Choose 'Phone#.'
Phone # 1.NAM1 2.NAM2	1	-Choose 'NAM1'
Phone # 1234567890	phone number OK : Mobile ID	Phone number currently used. -to change, enter new one. -stores it.
Mobile ID # 3003003000	mobile ID number OK : SVC Menu	Mobile ID number currently used. -to change, enter new one. -stores it.
SVC Menu	3	-Choose 'NAM1'
SETUP Menu 1.FM 2.CDMA	2	-Choose 'CDMA'
HOME SID 4369	ID number ja : CDMA FNID ja , OK : NID	System ID for home, current status is displayed. -to change, enter new one. -stores it.
IMSI_MCC 000	number OK, ja : IMSI_MNC	IMSI Mobile Country Code,current code is displayed. -to change, enter new one. -stores it.
IMSI_MNC 00	number OK, ja : CDMA ACCOLC ja : IMSI_MNC	IMSI Mobile Network Code,current code is displayed. -to change, enter new one. -stores it.
CDMA ACCOLC 0	class number OK, ja : CDMA HOME SID ja : IMSI_MNC	CDMA Access Overload Class,current status is displayed. -to change,enter new one. -stores it.
CDMA HOME SID Yes	ca ,or co OK, ja : CDMA fSID ja : CDMA ACCOLC	CDMA Home system ID, current status is displayed. -changes the status. -stores it.
CDMA fSID Yes	ca ,or co OK, ja : CDMA FNID ja : CDMA Home SID	CDMA foreign SID, current status is displayed. -changes the status. -stores it.
CDMA fNID Yes	ca ,or co OK, ja : Home SID ja : CDMA fSID	CDMA foreign NID, current status is displayed. -changes the status. -stores it.
NID	OK, ja : HOME SID	-Choose 'HOME SID'

Setting Up NAM2

LCD Display	Key in	Function
SVC Menu 1:Phone #	1	-Choose 'Basic.'
Phone # 1.NAM1 2.NAM2	2	-Choose 'NAM2'
Phone # 1234567890	phone number OK : Mobile ID	Phone number currently used. -to change, enter new one. -stores it.
Mobile ID # 3003003000	mobile ID number OK : SVC Menu	Mobile ID number currently used. -to change, enter new one. -stores it.
HOME SID 4369	ID number ja : CDMA fNID ja , OK : NID	System ID for home, current status is displayed. -to change, enter new one. -stores it.
IMSI_MCC 000	number OK , ja : IMSI_MNC	IMSI Mobile Country Code,current code is displayed. -to change, enter new one. -stores it.
IMSI_MNC 00	number OK , ja : CDMA ACCOLC ja : IMSI_MNC	IMSI Mobile Network Code,current code is displayed. -to change, enter new one. -stores it.
CDMA ACCOLC 0	class number OK , ja : CDMA Home SID ja : IMSI_MNC	CDMA Access Overload Class,current status is displayed. -to change,enter new one. -stores it.
CDMA HOME SID Yes	o , or o OK , ja : CDMA fSID ja : CDMA ACCOLC	CDMA Home system ID, current status is displayed. -changes the status. -stores it.
CDMA fSID Yes	o , or o OK , ja : Home fNID ja : CDMA Home SID	CDMA foreign SID, current status is displayed. -changes the status. -stores it.
CDMA fNID Yes	o , or o OK , ja : Home SID ja : CDMA fSID	CDMA foreign NID, current status is displayed. -changes the status. -stores it.
SVC Menu 1.Phone # 2.General 3.NAM1 4.NAM2	4	-Choose 'NAM2'
Setup NAM2 1.FM 2.CDMA	2	-Choose 'CDMA'

5. TEST PROCEDURE

TUNE-UP PROCEDURE

List of Equipment

- DC Power Supply
- Test Jig
- Test Cable
- CDMA Mobile Station Test Set HP8924C, HP83236A, CMD-80, etc
- Spectrum Analyzer(include CDMA test mode) HP8596E

Configuration of Test

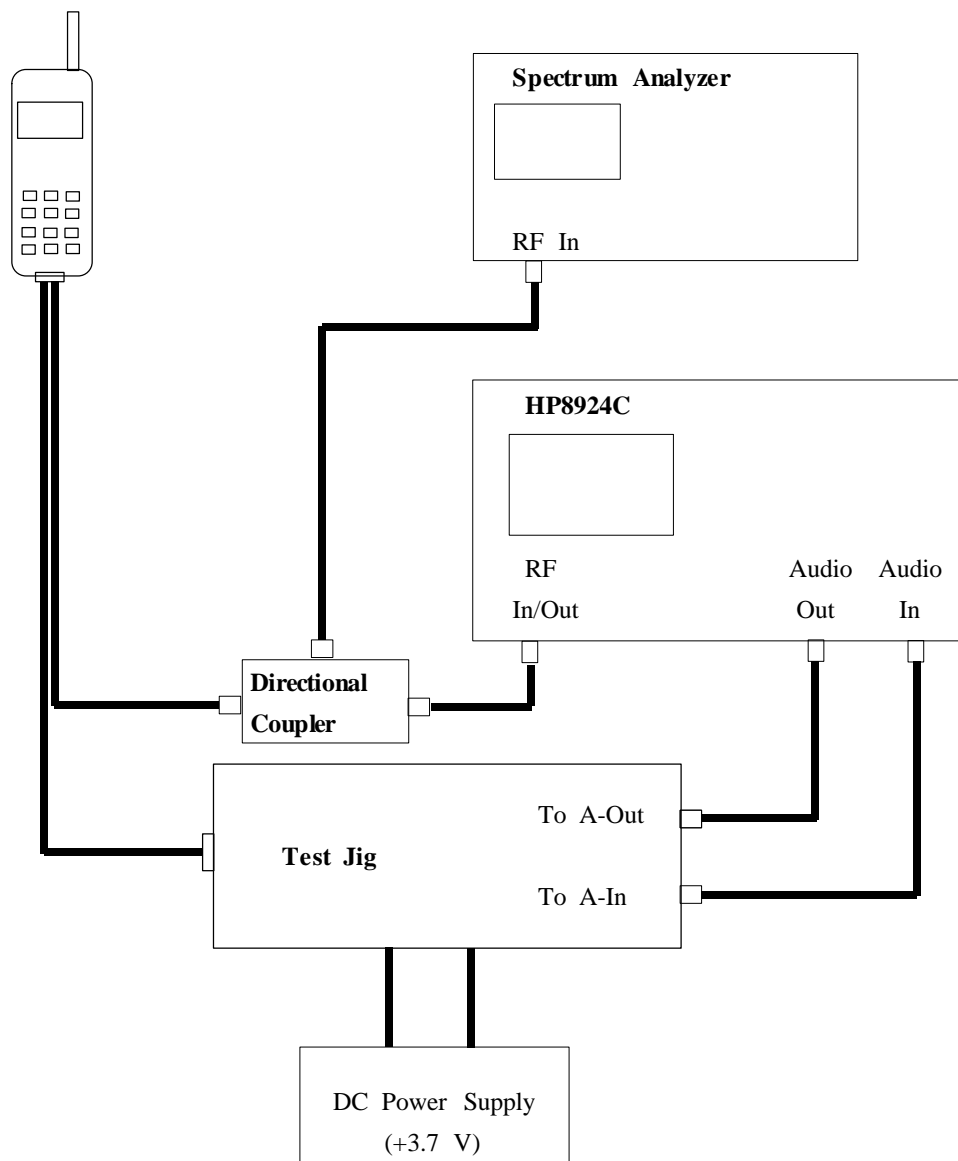

Change to Test Mode

A. To change the phone from Normal Mode to test Mode, You should enter the following keys.

" 4 7 * 8 6 9 # 1 2 3 5 "

B. The command $\text{j}^{\circ}0 1$ (Suspend) is entered to start test.

C. To finish the Test Mode, You should enter the command "0 2".

Channel Selection and Tx Power Output level Control

1. PCS

A. You should change the phone from Normal Mode to PCS(Home only) Test mode

: press [MENE 3], choose 'SPRINT PCS' by using $\text{j}^{\circ}\tilde{a}$ or $\text{j}^{\circ}\grave{a}$ key

: press [OK]

B. The command $\text{j}^{\circ}0 1$ (Suspend) is entered to start test : press [0 1]

C. You should enter the following keys.

" 0 9 0 6 0 0 #, 0 7, 3 4, 7 1 X X X "

- If you enter the command "0 9", You can select the channel

ex) 0 9 X X X X (under-bar means channel number)

- The command "0 7 \pm " means Carrier On (Carrier Off : $\text{j}^{\circ}0 8\pm$)

- If you enter the command "7 1", You can control the power output level. Following under-bar means AGC code. And you can control the power output level using [SEND] or [END] Keys.

ex) 7 1 4 7 5

- If you enter the command "3 4", You can spread the carrier.

D. After enter the command "7 4" and control the Tx Power Output Level to be 0.0dBm

using [SEND] or [END] key , press "OK" key to store Data in EEPROM.

2. AMPS

A. You should change the phone from Normal Mode to AMPS Test mode

B. The command 0 1 (Suspend) is entered to start test.

C. You should enter the following keys.

" 0 9 X X X X #, 0 7, 9 7 X X X "

- If you enter the command "0 9", You can select the channel

ex) 0 9 0 3 8 3 (under-bar means channel number)

- The command "0 7" means Carrier On (Carrier Off : 0 8)

- If you enter the command "9 2", You can control the power output level. Following under-bar means AGC code. And you can control the power output level using [SEND] or [END] key

ex) 9 2 4 7 5

D. Control the TX Power Output Level using [SEND] or [END] key.

When you press "OK" key to store Data in EEPROM, enter next power level control step automatically.

LEVEL	LCD Display	TX OUPUT POWER	STORE
2	TXpwr[02]	+26dBm +2 /-4dB	OK
3	TXpwr[03]	+24dBm +2 /-4dB	OK
4	TXpwr[04]	+20dBm +2 /-4dB	OK
5	TXpwr[05]	+16dBm +2 /-4dB	OK
6	TXpwr[06]	+12dBm +2 /-4dB	OK
7	TXpwr[07]	+ 8dBm +2 /-4dB	OK

Configuration of Test (Hands-Free)

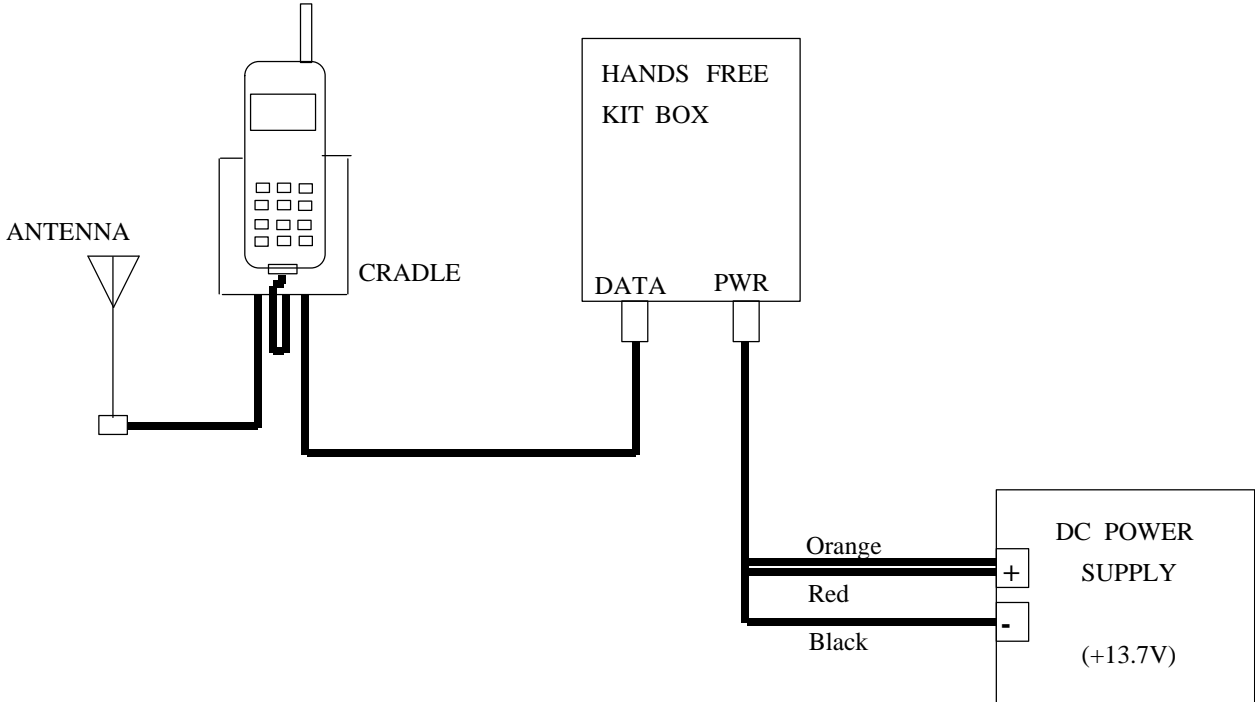

TEST CABLE DESCRIPTION FOR SCH-3500

1. TEST CABLE

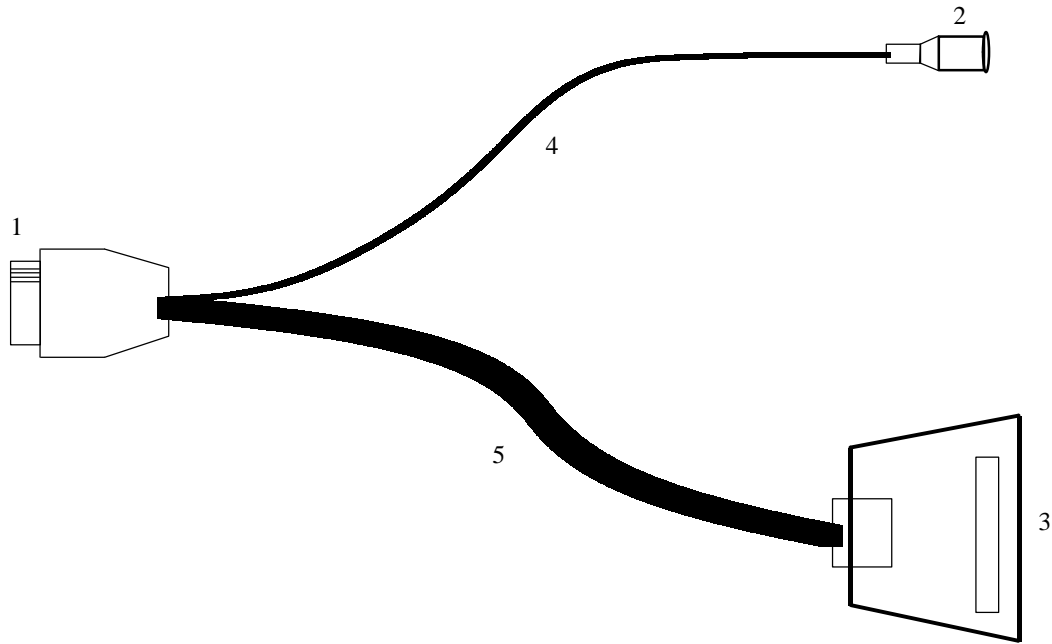

2. TEST CABLE CONNECTIONS

1	PLUG CONNECT TO SCH-3500
2	BNC CONNECTOR (RF)
3	Dsub 25PIN CONNECTOR (DATA)
4	RF CABLE
5	DATA CABLE

3. Dsub 25 PIN CONNECTOR PIN DESCRIPTION (TEST CABLE 1, BACK SIDE)

DATA DESCRIPTION	Dsub CONN. PIN NO.
Vcc	4, 5, 6
GND	13, 23, 24, 25
PW ON/OFF	7
TX AUDIO	10
TX DATA	22
RX AUDIO	12
RX DATA	21
RSSI	8

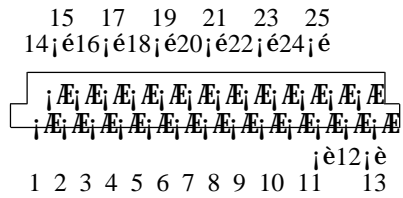

4. CONVERSION TABLE OF FREQUENCY vs CHANNEL

T Y P E	CHANNEL	CONVERSION EQUATION	REMARK
TX FREQUENCY	1 ; N ; 799 990 ; N ; 1023	F=0.03 ; N + 825.00 F=0.03 ; (N-1023) + 825.00	N ; CH NUMBER F ; FREQUENCY
RX FREQUENCY	1 ; N ; 799 990 ; N ; 1023	F=0.03 ; N + 870.00 F=0.03 ; (N-1023) + 870.00	

AMPS MODE

TEST ITEM	STEP	PROCEDURE
1. PREPARE	<p>a</p> <p>b</p> <p>c</p> <p>d</p> <p>e</p> <p>f</p>	<p>Connect the test equipment</p> <p>Select AMPS mode:press[MENU 3], choose 'Analog' and press [OK].</p> <p>Enter the test mode: press [4 7 * 8 6 9 # 1 2 3 5]</p> <p>Press [0 1] : You must do it at first in FM test mode.</p> <p>If you press a wrong key, press [#] key and then enter new command.</p> <p>To exit the test mode at any time : press [0 2]</p>
2. RF POWER	<p>a</p> <p>b</p> <p>c</p> <p>d</p> <p>e</p> <p>f</p>	<p>Set the channel 383 : Press [0 9 0 3 6 3] (Ch number must be 4 digits)</p> <p>Turn the carrier on, and set the power level 2 : press [0 7 1 0 2]</p> <p>Measure the RF Power Output : + 26 dBm +2/ -4 dB</p> <p>Note 1 : In case of using the antenna cable, must compensate for the cable loss.</p> <p>Note 2 : To prevent from damaging the hhp, must measure by calibrated test equipment.</p> <p>Warning !</p> <p>Adjustments without calibrated equipment can result in excessive heat and will void the warranty.</p> <p>Power level control mode is [1 0 X] Adjust power level by using [SEND] or [END]key, and store. : press [9 2]</p> <p>Then measure the power output for each level by pressing [OK] at every step .</p> <p>Then turn carrier off : press [0 8]</p>
3. TX FREQUENCY	<p>a</p> <p>b</p> <p>c</p> <p>d</p>	<p>Set the channel 383 : press [0 9 0 3 6 3]</p> <p>Turn the carrier on : press [0 7]</p> <p>Measure the tx frequency : 836.490MHz $\pm \frac{3}{4}$ 2.5ppm ($\pm \frac{3}{4}$2090Hz)</p> <p>Turn the carrier off : press [0 8]</p>

TEST ITEM	STEP	PROCEDURE
4. VOICE DEVIATION	<p>a</p> <p>b</p> <p>c</p> <p>d</p> <p>e</p> <p>f</p> <p>g</p> <p>h</p> <p>i</p> <p>l</p>	<p>Set the channel 383 : [0 9 0 3 6 3]</p> <p>Send the RF power, and set TX audio unmute :press [0 7 4 6 1 4]</p> <p>Turn the carrier on, and set the power level 2</p> <p>Set the audio generator output to 1KHz, 7.0Vrms Measure the TX voice deviation by using the HPF of 20Hz and the LPF of 99kHz. (spec : ± 12KHz less)</p> <p>To adjust the peak deviation, (¥) Press [6 3] and use the [SEND] or [END] key (¥) Store the peak deviation : press [OK]</p> <p>Set the audio generator output to 1KHz, 70Vrms.</p> <p>Measure the TX voice deviation by using the HPF of Cmessage and the LPF of 15kHz. (spec : ± 2.9 kHz $\pm 10\%$)</p> <p>To adjust the compressor off deviation : press [60], and use [SEND] or [END] key. (spec : ± 2.9 kHz ± 0.2 kHz)</p> <p>Store the compressor off deviation : press [OK]</p> <p>Turn the carrier off, and TX mute : [0 8 1 3]</p>
5. ST DEVIATION	<p>a</p> <p>b</p> <p>c</p> <p>d</p> <p>e</p> <p>f</p> <p>g</p>	<p>Set the channel 383 : press [0 9 0 3 6 3]</p> <p>Turn the carrier on, and set the power level 2</p> <p>Set ST : press [1 6]</p> <p>Measure the TX ST deviation by using the HPF of 20Hz and the LPF of 15kHz. (spec : ± 8 kHz 10%)</p> <p>To adjust the deviation ; press [66], and use [SEND] or [END] key.</p> <p>Store the deviation code in EEPROM : press [OK]</p> <p>Turn the ST and the carrier off : press [1 7 0 8]</p>

TEST ITEM	STEP	PROCEDURE
6. SAT DEVIATION	a	Set the channel 383 : [0 9 0 3 6 3]
	b	Turn the carrier on, and set the power level 2
	c	Set the Voice State and SAT on : press [4 6 3 2 1]
	d	Measure the TX SAT deviation by using the HPF of 20 Hz and the BPF of 6 kHz. (spec : ± 2 kHz $\pm 10\%$)
	e	To adjust the deviation within specification : press [64], and use [SEND] or [END] key.
	f	Store the deviation code in EEPROM: press [OK]
	g	Turn the SAT and the carrier off : press [3 3 0 8]
7. WBD DEVIATION	a	Set the channel and carrier on : [0 9 0 3 6 3 0 7]
	b	WBD on : [3 4]
	c	Measure the WBD deviation by using the HPF of 20 Hz and the LPF of 99 kHz. (spec : ± 8 kHz $\pm 10\%$)
	d	To adjust the WBD deviation : press [6 5], and use [SEND] or [END] key.
	e	Store the deviation code in EEPROM : press [OK]
	f	Turn the carrier off : press [0 8]
8. RX AUDIO	a	Set the equipment as below. RF frequency : 881.49 MHz Input RF level : - 80 dBm Modulation frequency : 1 KHz Frequency deviation : 8 KHz
	b	Set the channel 383 and the Voice State : press [0 9 0 3 6 3 4 6]
	c	Set the RX audio unmute : press [1 2]
	d	Set compandor on : press [4 4]
	e	Set speaker power level : Press [1 3]
	f	Adjust the expandor on audio level : press [6 1] Use [SEND] or [END] key.
	g	Store the expandor on audio level :press [OK]
	h	Finish the test and exit test mode : press [0 2]

PCS MODE

TEST ITEM	STEP	PROCEDURE
1. PREPARE	a b c d e f	Connect the test equipment Select FM mode: press [MENU 0], choose 'HOME ONLY' Store the PCS mode: press [OK] Enter the test mode: press [4 7 * 8 6 9 # 1 2 3 5] If you press a wrong key, press [#] key and then enter new command. To exit the test mode at any time : press [0 2]
2. FREQUENCY ACCURACY	a b c d e	Set the channel 600: press [0 9 0 6 0 0] Turn the carrier on and set the power level. : press [0 7 3 4 7 1 X X X] Measure the frequency accuracy (spec: $\pm 300\text{Hz}$) To adjust the Frequency Accuracy : press [8 9] and use [SEND] or [END] key. Store the Frequency Accuracy in EEPROM: Press [OK]
3. OCCUPIED CDMA BAND WIDTH	a b c	Set the channel 600 : press [0 9 0 6 0 0] Turn the carrier on and set the power level. : press [0 7 3 4 7 1 X X X] Measure the Band Width. (spec: 1.32MHz)
4. LIMITATIONS ON EMISSIONS	a b c	Set the channel 600: press [0 9 0 6 0 0] Turn the carrier on and set the power level. : press [0 7 3 4 7 1 X X X] Measure the spurious at $F_c \pm 1.25\text{MHz}$, $2F_c$, $3F_c$, $1/2F_c$ spec: $F_c \pm 1.25\text{MHz}$ below 42dBc/30KHz Outside Receive Band $-43+10\log(\text{PY})$ PY: Mean output power in watts
5. GATED POWER & TIME	a b c d e	Set the Service option: 2 Set the Data Rate: Eighth (1200bps) Registering: HHP --> HP8924C Call : HP8924C --> HHP Measure the Gated Power & Time spec: Gated Power at least 20dB Gated Time - Rising Time: below 6us Falling Time: below 6us Burst Time: below 1.25ms