

CLASS II PERMISSIVE CHANGE

SAMSUNG ELECTRONICS CO., LTD.

Product : **Notebook Computer**

Model No. : **SENS Pro 720**

FCC ID : **A3LS720**

DATE : **November 5, 1998**

SAMSUNG Reference NO. : 981110

This test report is to certify that the tested device properly complies with the requirements of FCC Rules and Regulations Part 15 Subpart B Unintentional Radiators. All tests necessary to show compliance to the requirements were and these results met the specifications requirement.

1. Applicant Name : SAMSUNG ELECTRONICS CO., LTD.
(Company name & Address) 416 Maetan 3 Dong, Paldal-Ku,
Suwon City, Kyungki Do, Korea,
441-742

2. Identification of tested device

2.1 FCC ID : A3LS720
2.2 Device Name : Notebook Computer
2.3 Brand (Trade Name) : SAMSUNG
2.4 Model Number : SENS Pro 720

3. Test Procedure and Items

3.1 AC Powerline Conducted Emissions Measurement : ANSI C63.4-1992
3.2 Radiated Emissions Measurement : ANSI C63.4-1992

4. Issued Date : November 5, 1998

TESTED BY : N. C. Park
No-Cheon, PARK / Test Engineer

APPROVED BY : T. J. Shin
Taek-Jeong, SHIN / Manager of EMC Lab.

TABLE OF CONTENTS

1. GENERAL INFORMATION
 - 1.1 Product Description
 - 1.2 Permissive Contents(Alternative LCD)
 - 1.3 Grants
 - 1.4 Tested System Details
 - 1.5 Test Methodology
 - 1.6 Test Facility

2. SYSTEM TEST CONFIGURATION
 - 2.1 Justification
 - 2.2 Video Mode Justification
 - 2.3 EUT Exercise Software
 - 2.4 Special Accessories
 - 2.5 Equipment Modification
 - 2.6 Test System configuration
 - 2.7 Photographs

3. CONDUCTED EMISSION DATA

4. RADIATED EMISSION DATA

5. LIST OF TEST INSTRUMENT

1. General Information

1.1 Product Description

The Samsung Electronics Co., Ltd. Notebook Computer Model SENS Pro 720(FCC ID :A3LN720)is based on the powerful Pentium II processor. It can be operated from rechargeable battery pack or by 100-240V AC Adapter(with ferrite bead).

1.2 Permissive Contents(Alternative LCD)

Unit	From	To	Remark
LCD	12.1", 13.3"	12.1", 13.3" and LCD 14.1"(LT141X4)	Refer to photographs
# This model is identical to the basic model except for the LCD unit and LCD cover.			

1.3 Grants

The EUT was tested with a External FDD. Samsung does not intend to market this as a separate unit; therefore, an application for certification is not being filed. This device will be supplied with this computer.

1.4 Test System Details

The FCC IDs for all equipment plus descriptions of all cables used with the tested system (including inserted cards which have grant) are:

FCC ID	DESCRIPTION (Model Name)	CABLE DESCRIPTION
A3LS720	EUT (SENS Pro 720)	-
A3LCST768	External Monitor (CST7687L)	Shielded interface
D2LCC	Serial Mouse (M-CG7)	Unshielded interface
GJJSKR-1032B	Keyboard (SEM-K15Z)	Unshielded interface
N/A	AC Adaper (AD-5019)	Unshielded interface
N/A	USB Termination cable	Unshielded interface
A3LSPR500E	Port Replicator (SPR-500E)	Unshielded interface
N/A	TelePhone (SSP-2501)	Unshielded interface
N/A	Microphone (YMC-2511)	Unshielded interface
DSI16XU222	Inkjet Printer (2225C)	Shielded interface
N/A	PCMCIA(SLOTS-2EA)FLASH MEMORY	-
N/A	External FDD (SFD-600E)	Unshielded interface
N/A	Loud Speaker (BS-211)	Unshielded interface

1.5 Test Methodology

Both radiated and conducted tests were performed according to the procedure in ANSI C63.4-1992. Radiated testing was performed at an antenna-to-EUT distance of three meters.

1.6 Test Facility

All test described in this report were performed by :

SAMSUNG ELECTRONICS CO., LTD.
EMC TESTING LABORATORY
416 Maetan 3 Dong, Paldal-Ku,
Suwon City, Kyungki Do, Korea, 441-742
Open area test site (3 meter) and Shielded Room.

This test facility has been filed in FCC under the criteria in ANSI C63.4-1992.

2. SYSTEM TEST CONFIGURATION

2.1 Justification

The system was configured for testing in typical fashion (as a customer would use it). The EUT has internal clock speeds of 14.318, 33, 48 56.448 and 66.6MHz. And the EUT have various CPUs(233,266 and 300MHz speed CPU) The EUT was investigated while operating at all speeds. The highest speed of 300MHz CPU was used for final testing as it was found to cause worst case emissions. And the EUT has LCD displays of 14.1" TFT type.

The EUT's video circuitry is capable of operating at a maximum non-interlaced resolution of 1024x768 pixels. The EUT was observed while scrolling a continuous stream for capital "H's" in the 1024x768 mode(both LCD display and External Monitor).

Comparing the test results without port replicator and with port replicator. The test result without port replicator was found the worst case emissions. And so the final testing was performed without port replicator.

The EUT was tested with a Samsung AC Adapter Model number AD-5019. Further details of cabling and configuration are shown in the test system configuration.

2.2 Video Mode Justification

The system was tested in 1024x768 resolution mode and in the highest resolution mode of 1024x768. Since the 1024x768 resolution mode(LCD & External Monitor both in use) was found to be worst case, this mode was used to collect the included data.

2.3 EUT Exercise Software

The EUT exercise program used during testing was designed to exercise the system in a manner similar to a typical use. This program was contained on the EUT's Hard Disk and Floppy Disk. Once loaded, the program sequentially exercise each system component in turn. The sequence used was : 1) serial "H"s scrolled to the LCD and Monitor; 2) copy series of "H"s characters to mass storage device.

3) print series of H characters to printer. Since the mouse and speaker are strictly input device, no data was transmitted to them during testing. They are, however, continuously scanned for data input activity.

2.4 Special Accessories

As shown in Test System configuration, all interface cables used for compliance testing are unshielded. The Samsung AC adapter and Floppy disk drive connect cable has a ferrite bead on the line as supplied by the manufacturer.

The ferrite specification that used on AC adapter and floppy disk drive connection cable. The following is ferrite specification.

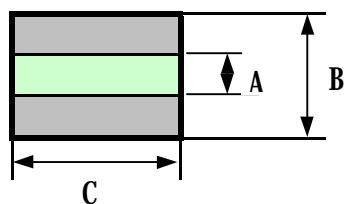

Ext. FDD

A : 7mm

B : 18mm

C : 32mm

AC Adapter

A : 4.7mm

B : 9.8mm

C : 24.5mm

2.5 Equipment Modifications

No equipment modifications were performed during testing.

2.6 Test System configuration

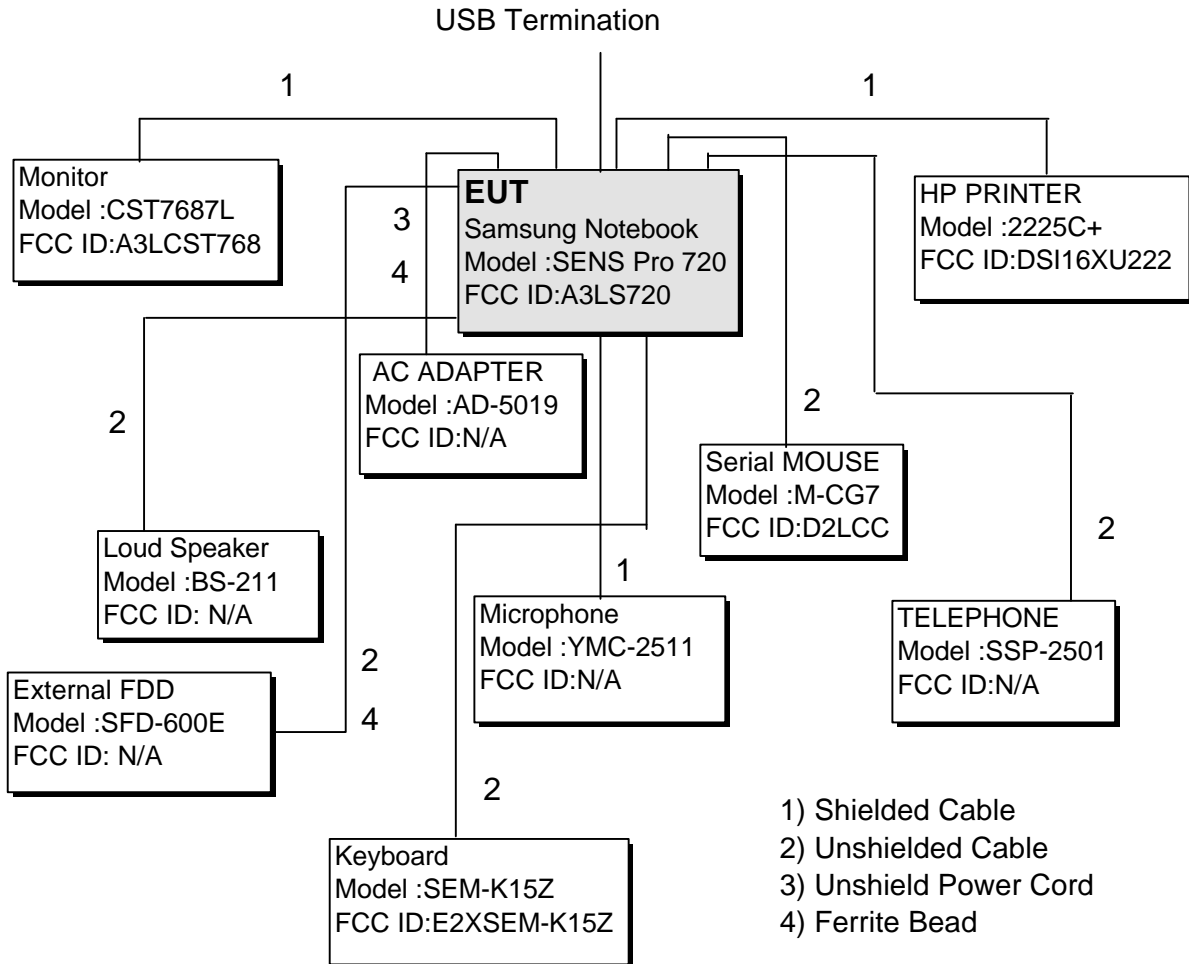

2.7 Photographs

***;* \hat{U} Radiation(Front View)**



***;* \hat{U} Radiation(Rear View)**

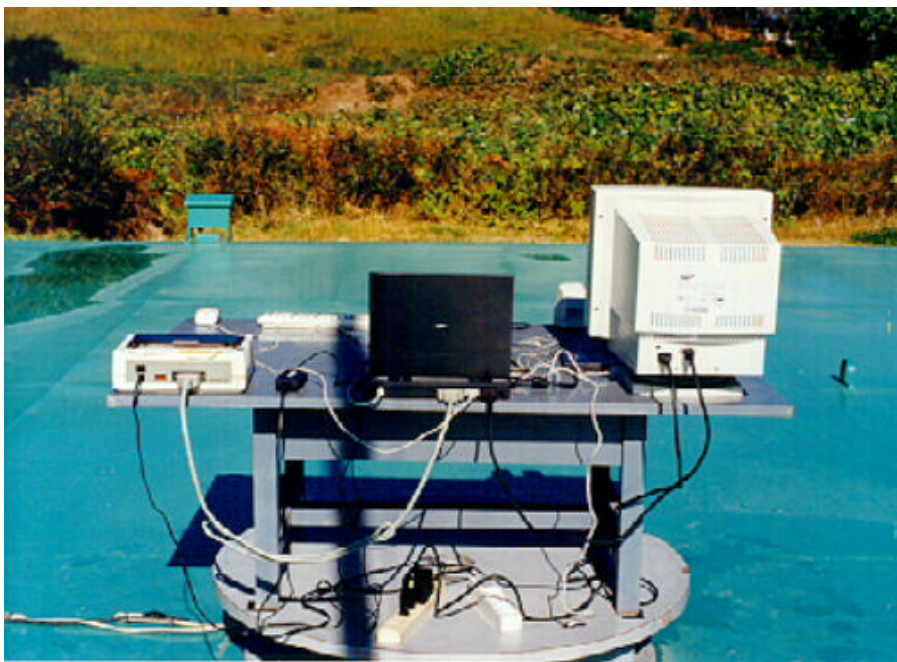

;Û Conduction(Front View)



;Û Conduction(Side View)

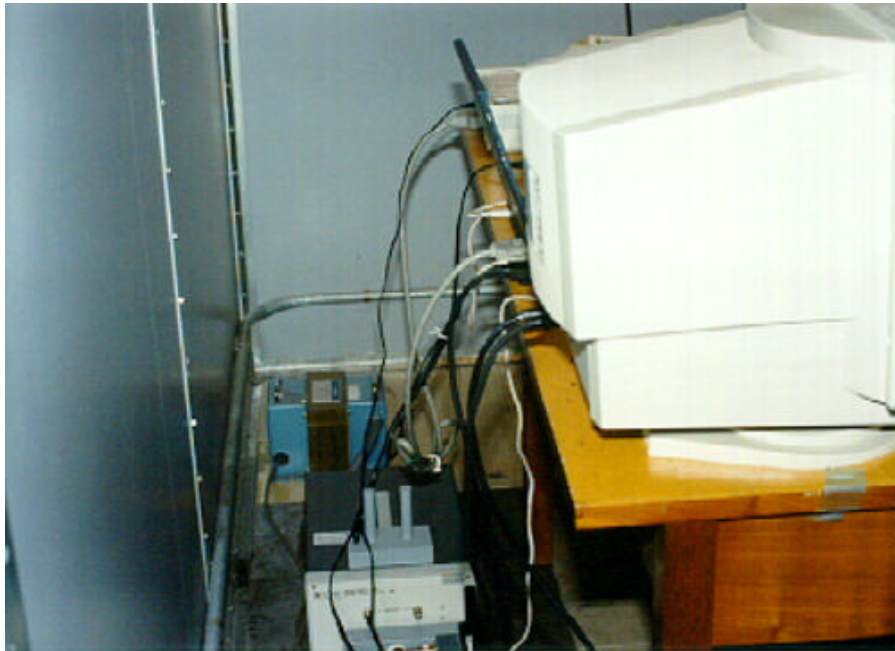

3. CONDUCTED EMISSION DATA

The initial step in collecting conducted data was to perform a quasi-peak scan over the measurement range using a spectrum analyzer.

Sample Calculation

Frequency : 0.477 [MHz]
 Meter Reading : 38.3 [dBuV]
 Factor of LISN : 0.1 [dB]

Then, Result is calculated as follows.

$$38.3 + 0.1 = 38.4 \text{ [dBuV]}$$

Test Data Sheet

Tested Frequency [MHz]	Meter Reading (Quasi-Peak) [A] [dBuV]	LISN Pol. [L1,L2]	Total Loss	Results	Limits [dBuV]	FCC Margin [dB]
			[B]	[A+B]		
			[dB]	[dBuV]		
0.477	38.3	L2	0.1	38.4	48	9.6
0.482	38.2	L1	0.1	38.3	48	9.7
0.546	35.2	L1	0.1	35.3	48	12.7
0.549	40.1	L2	0.1	40.2	48	7.8
0.753	39.3	L2	0.1	39.4	48	8.6
0.957	39.1	L2	0.1	39.2	48	8.8

4. RADIATED EMISSION DATA

The initial step in collecting radiated data was to perform a quasi-peak scan over the measurement range using a spectrum analyzer. All modes of operation were investigated and the worst-case emission are reported. All other emission are non-significant.

Sample Calculation

Frequency : 41.6 [MHz]
 Meter Reading : 15 [dBuV]
 Total of Loss : 13.9 [dB]

Then, Result is calculated as follows.

$$15 + 13.9 = 28.9 \text{ [dBuV]}$$

Test Data Sheet

Frequency Range [MHz]	Tested Frequency [MHz]	ANT Pol.	Meter Reading [A] [dBuV/m]	Total Loss [B] [dB]	Results [A+B] [dBuV/m]	FCC Margin [dB]	Limits [3m] [dBuV/m]
30 - 88	41.6	V	15.0	13.9	28.9	11.1	40.0
	51.6	H	20.4	11.17	31.57	8.43	
	52.7	V	23.5	11.2	34.7	5.3	
	75.9	H	25.3	9.15	34.45	5.55	
	77.9	H	20.9	9.3	30.2	9.8	
	78.3	H	22.5	9.3	31.8	8.2	
88 - 216	100.5	H	25.3	9.9	35.2	8.3	43.5
	152.3	H	25.5	10	35.5	8	
	176.1	H	24.7	11.05	35.75	7.75	
	182.6	H	24.5	11.2	35.7	7.8	
	189	H	24.0	11.6	35.6	7.9	
	215.2	H	24.8	12.6	37.4	6.1	
216 - 960	228.2	H	23.9	13.25	37.15	8.85	46.0
	247.6	H	23.8	14.15	37.95	8.05	
	260.9	H	26.9	14.6	41.5	4.5	
	283	H	26.9	15.62	42.52	3.48	
	324.5	H	20.5	16.75	37.25	8.75	
	734.6	H	16.4	26	42.4	3.6	
960 -	961.2	H	<6	31.4	-	-	54.0
	1242.2	H	<6	31.5	-	-	
	1778.4	H	-	36.4	-	-	

[NOTE] "<" Means equal or less than

Receiving Antenna polarization : **Horizontal, Vertical**

5. LIST OF TEST INSTRUMENT.

Equipment	Model No.	Serial No.	Makers	Calibration Last calibration and Interval
Spectrum analyzer	8566B	2611A02672	H.P	98/ 9/21, 12Months
Quasi-peak adapter	85650A	2521A00687	H.P	98/ 9/21, 12Months
RF Preselector	85685A	2602A00224	H.P	98/ 9/21, 12Months
Field strength meter	ESS	844861/005	R & S	98/ 3/16, 12Months
	ESVP	860688/015	R & S	98/ 9/21, 12Months
Pre-amplifier	8447D	2443A04331	H.P	97/12/22, 12Months
L.I.S.N	3825-2	9208-1981	EMCO	98/ 9/ 5, 12Months
Double Ridged WaveGuide	3115	4028	EMCO	98/10/ 2, 12Months
Bi-conical Antenna	3110B	2012	EMCO	97/12/ 1, 12Months
Log-periodic Antenna	3146A	1320	EMCO	97/12/ 1, 12Months