

**SAMSUNG**

# **RT4401-48A Installation Manual**

*<Replace this text with a short document summary of no more two or three lines>*

Document Version 3.0  
February 2019

*Radio Access Network*

**Document Number: 2600-00NETNGAA**

© 2019 SAMSUNG Electronics Co., Ltd.

All Rights Reserved. No part of this document shall be photocopied, reproduced, stored in a retrieval system, or transmitted, in any form or by any means whether, electronic, mechanical, or otherwise without the prior written permission of SAMSUNG Electronics Co., Ltd.

No warranty of accuracy is given concerning the contents of the information contained in this publication. To the extent permitted by law no liability (including liability to any person by reason of negligence) will be accepted by SAMSUNG Electronics Co., Ltd., its subsidiaries or employees for any direct or indirect loss or damage caused by omissions from or inaccuracies in this document. SAMSUNG Electronics Co., Ltd. reserves the right to change details in this publication without notice.

SNMTC-v3-0312

This manual should be read and used as a guideline for properly installing and/or operating the product. Owing to product variations across the range, any illustrations and photographs used in this manual may not be a wholly accurate depiction of the actual products you are using. This manual may be changed for system improvement, standardization and other technical reasons without prior notice. Samsung Networks documentation is available at <http://www.samsungdocs.com>

# Contents

---

<b>Preface</b>	<b>x</b>
Conventions in this Document .....	x
New and Changed Information .....	xi
Revision History.....	xi
Organization of This Document .....	xi
Related Documentation .....	xi
Personal and Product Safety .....	xii
Equipment Markings .....	xvi
<b>Chapter 1 Before Installation</b>	<b>1</b>
System View and External Interface .....	1
<i>System View</i> .....	1
<i>System External Interface</i> .....	2
Specifications .....	5
Cautions for Installation .....	7
<i>Before Installing</i> .....	7
<i>While Installing</i> .....	7
<i>After Installing</i> .....	8
Installation Tools .....	9
<b>Chapter 2 Installing System</b>	<b>12</b>
Installation Procedure .....	12
System Arrangement .....	13
<i>Using Tilting and Swiveling Bracket</i> .....	13
<i>Using Tilting Bracket</i> .....	16
<i>Without Tilting Bracket</i> .....	17
<i>Using Side by Side Bracket</i> .....	17
Transporting and Unpacking .....	19
<i>Bringing in Items</i> .....	19
<i>Unpacking</i> .....	19
Fixing RRH .....	20
<i>Assembling Clip on Antenna</i> .....	20
<i>Assembling AC-DC Power Unit</i> .....	24
<i>Using Tilting and Swiveling Bracket</i> .....	26
<i>Using Tilting Bracket</i> .....	46
<i>Without the Tilting Bracket</i> .....	54
<i>Using Side by Side Bracket</i> .....	62
<b>Chapter 3 Connecting Cables</b>	<b>80</b>
Cabling Procedure .....	80
Guidelines for Cable Connections .....	81
<i>Cable Path Inspection</i> .....	81
<i>Cable Cutting</i> .....	82
<i>Cable Installation</i> .....	82
<i>Cable Binding</i> .....	83
<i>Connector Attachment</i> .....	83
<i>Identification Tag Attachment</i> .....	84
Cabling Diagram .....	85

---

Grounding .....	87
<i>Connecting Ground Cable</i> .....	87
Power Cabling .....	92
<i>Connecting Power Cable</i> .....	93
Interface Cable Connection .....	104
<i>Remove/Insert Optical Module</i> .....	104
<i>Connecting CPRI Cable</i> .....	106
<i>Connecting UDA Cable</i> .....	110
<i>Connecting RET Cable</i> .....	115
<i>Connecting RF Cable (External RF Antenna connection)</i> .....	118
Assembling Cable Cover .....	124
<b>Chapter 4 Inspect the Installation</b> .....	<b>126</b>
<b>Appendix A Acronyms</b> .....	<b>130</b>
<b>Appendix B Clean the Optical Connectors</b> .....	<b>131</b>
Introduction .....	131
<i>Measure the Optical Output and Connecting the Optical Connector</i> .....	131
<b>Appendix C Standard Torque</b> .....	<b>133</b>

# List of Figures

---

Figure 1.	System View (RRH only) .....	1
Figure 2.	System View (with Clip-on: Antenna + AC-DC Power Unit).....	2
Figure 3.	System External Interface (RRH only) .....	3
Figure 4.	System External Interface (with Clip-on: Antenna + AC-DC Power Unit).....	3
Figure 5.	Procedure to Install the RRH .....	12
Figure 6.	RRH Arrangement_1 Sector Pole Type Installation .....	13
Figure 7.	RRH Arrangement_1 Sector Wall Type Installation .....	14
Figure 8.	RRH Arrangement_1 Sector Tilting .....	14
Figure 9.	RRH Arrangement_Swivelling .....	15
Figure 10.	RRH Arrangement_3 Sector Pole Type Installation .....	16
Figure 11.	RRH Arrangement_3 Sector Tilting .....	16
Figure 12.	RRH Arrangement_3 Sector Pole Type Installation .....	17
Figure 13.	RRH Arrangement_3 Sector Pole Type Side by Side Installation .....	18
Figure 14.	RRH Arrangement_3 Sector Wall Type Side by Side Installation .....	18
Figure 15.	Assembling Clip on Antenna (1) .....	20
Figure 16.	Assembling Clip on Antenna (2) .....	21
Figure 17.	Assembling Clip on Antenna (3) .....	22
Figure 18.	Assembling Clip on Antenna (4) .....	23
Figure 19.	Assembling Clip on Antenna (5) .....	24
Figure 20.	Assembling AC-DC Power Unit (1).....	25
Figure 21.	Assembling AC-DC Power Unit (2).....	26
Figure 22.	Fixing Unit Bracket (1) .....	27
Figure 23.	Fixing Unit Bracket (2) .....	27
Figure 24.	Fixing Unit Bracket (3) .....	28
Figure 25.	Fixing Mounting Bracket on the Pole (1).....	29
Figure 26.	Fixing Mounting Bracket on the Pole (2).....	29
Figure 27.	Fixing Mounting Bracket on the Pole (3).....	30
Figure 28.	Fixing Mounting Bracket on the Pole (4).....	30
Figure 29.	Lifting RRH .....	31
Figure 30.	Fixing RRH on the Pole (1).....	32
Figure 31.	Fixing RRH on the Pole (2).....	33
Figure 32.	RRH Marking Dimensions.....	35
Figure 33.	Marking .....	36
Figure 34.	Drilling .....	37
Figure 35.	Fixing Mounting Bracket on the Wall (1) .....	38
Figure 36.	Fixing Mounting Bracket on the Wall (2) .....	38
Figure 37.	Fixing RRH on the Wall (1).....	39
Figure 38.	Fixing RRH on the Wall (2).....	40
Figure 39.	RRH Tilting Adjustment (1).....	41
Figure 40.	RRH Tilting Adjustment (2).....	42
Figure 41.	RRH Tilting Adjustment (3).....	43
Figure 42.	RRH Swivelling Adjustment (1).....	44
Figure 43.	RRH Swivelling Adjustment (2).....	45
Figure 44.	RRH Swivelling Adjustment (3).....	46
Figure 45.	Fixing Mounting Bracket on the Pole (1).....	48
Figure 46.	Fixing Mounting Bracket on the Pole (2).....	49
Figure 47.	Fixing Mounting Bracket on the Pole (3).....	49

Figure 48.	Fixing Mounting Bracket on the Pole (4).....	50
Figure 49.	Lifting RRH .....	51
Figure 50.	Fixing RRHs on the 3Sector Pole Type (1) .....	52
Figure 51.	Fixing RRHs on the 3Sector Pole Type (2) .....	53
Figure 52.	Fixing RRHs on the 3Sector Pole Type (3) .....	54
Figure 53.	Fixing Unit Bracket (1) .....	55
Figure 54.	Fixing Unit Bracket (2) .....	55
Figure 55.	Fixing Mounting Bracket on the Pole (1).....	57
Figure 56.	Fixing Mounting Bracket on the Pole (2).....	58
Figure 57.	Fixing Mounting Bracket on the Pole (3).....	58
Figure 58.	Fixing Mounting Bracket on the Pole (4).....	59
Figure 59.	Fixing RRHs on the Pole (1) .....	60
Figure 60.	Fixing RRHs on the Pole (2) .....	61
Figure 61.	Fixing RRHs on the Pole (3) .....	61
Figure 62.	Fixing RRHs on the Pole (4) .....	62
Figure 63.	Fixing Unit Bracket_Side Installation (1) .....	63
Figure 64.	Fixing Unit Bracket_Side Installation (2) .....	63
Figure 65.	Assembling Mounting Bracket Assembly_Pole Type (1) .....	64
Figure 66.	Assembling Mounting Bracket Assembly_Pole Type (2) .....	65
Figure 67.	Assembling Mounting Bracket Assembly_Pole Type (3) .....	65
Figure 68.	Fixing Side by Side Bracket Assembly_Pole Type (1).....	66
Figure 69.	Fixing Side by Side Bracket Assembly_Pole Type (2).....	66
Figure 70.	Fixing Side by Side Bracket Assembly_Pole Type (3).....	67
Figure 71.	Fixing Side by Side Bracket Assembly_Pole Type (4).....	67
Figure 72.	Levelling Side by Side Bracket Assembly_Pole Type .....	68
Figure 73.	Fixing RRH on the Pole Type Side by Side Installation (1) .....	70
Figure 74.	Fixing RRH on the Pole Type Side by Side Installation (2) .....	70
Figure 75.	RRH Marking Dimensions.....	72
Figure 76.	Marking .....	72
Figure 77.	Drilling.....	73
Figure 78.	Fixing Side by Side Bracket on the Wall (1) .....	74
Figure 79.	Fixing Side by Side Bracket on the Wall (2) .....	75
Figure 80.	Fixing Side by Side Bracket on the Wall (3) .....	76
Figure 81.	Fixing RRH on the Wall (1).....	78
Figure 82.	Fixing RRH on the Wall (2).....	78
Figure 83.	Procedure to Connect System Cable.....	80
Figure 84.	Cable Connection Procedure.....	81
Figure 85.	RRH Cable Diagram (RRH only) .....	85
Figure 86.	RRH Cable Diagram (with Clip-on Antenna and AC-DC Power Unit).....	86
Figure 87.	Connecting Ground Cable_only RRH (1) .....	89
Figure 88.	Connecting Ground Cable_with AC-DC Power Unit (2).....	89
Figure 89.	Connecting Ground Cable_only RRH (3) .....	90
Figure 90.	Connecting Ground Cable_with AC-DC Power Unit (4).....	91
Figure 91.	Power Equipment Elements_RRH only .....	92
Figure 92.	Power Equipment Elements_with AC-DC Power Unit.....	92
Figure 93.	Connecting DC Link Cable (1) .....	94
Figure 94.	Connecting DC Link Cable (2) .....	94
Figure 95.	Connecting DC Link Cable (3) .....	95
Figure 96.	Connecting AC/DC Power Unit AC Power Cable (1) .....	97
Figure 97.	Connecting AC/DC Power Unit AC Power Cable (2) .....	98
Figure 98.	Connecting AC/DC Power Unit AC Power Cable (3) .....	98
Figure 99.	Connecting DC Power Cable (1) .....	100

---

Figure 100.	Connecting DC Power Cable (2) .....	101
Figure 101.	Connecting DC Power Cable (3) .....	102
Figure 102.	Optical Module Removal (1) .....	104
Figure 103.	Optical Module Removal (2) .....	104
Figure 104.	Optical Module Removal (3) .....	105
Figure 105.	Optical Module Insert .....	105
Figure 106.	Connecting CPRI Cable (1).....	107
Figure 107.	Connecting CPRI Cable (2).....	107
Figure 108.	Connecting CPRI Cable (3).....	108
Figure 109.	Connecting CPRI Cable (4).....	109
Figure 110.	Connecting CPRI Cable (5).....	109
Figure 111.	Connecting UDA Cable (1).....	111
Figure 112.	Connecting UDA Cable (2).....	112
Figure 113.	Connecting UDA Cable (3).....	113
Figure 114.	Connecting UDA Cable (4).....	114
Figure 115.	Connecting RET Cable (1).....	116
Figure 116.	Connecting RET Cable (2).....	117
Figure 117.	Connecting RET Cable (3).....	117
Figure 118.	Connecting RET Cable (4).....	117
Figure 119.	Connecting RF Cable (1).....	119
Figure 120.	Connecting RF Cable (2).....	119
Figure 121.	Connecting RF Cable (3).....	120
Figure 122.	Connecting RF Cable (4).....	120
Figure 123.	Connecting RF Cable (5).....	121
Figure 124.	Connecting RF Cable (6).....	122
Figure 125.	Connecting RF Cable (7).....	123
Figure 126.	Assembling Cable Cover (1).....	124
Figure 127.	Assembling Cable Cover (2).....	125
Figure 128.	Installation Inspection Procedure .....	126

# List of Tables

---

Table 1.	Specifications .....	5
Table 2.	AC/DC Power Unit Specifications .....	6
Table 3.	Basic Installation Tools .....	9
Table 4.	Parts and Tools for Assembling Clip on Antenna on RRH.....	20
Table 5.	Parts and Tools for Assembling AC-DC Power Unit on RRH .....	24
Table 6.	Parts and Tools for Fixing Unit Bracket on RRH .....	26
Table 7.	Parts and Tools for Fixing Mounting Bracket on the Pole .....	28
Table 8.	Parts and Tools for Fixing RRH on the Pole .....	31
Table 9.	Tools for Marking .....	34
Table 10.	Parts and Tools for Drilling .....	36
Table 11.	Anchor Bolt Drill Bits and Hole Depth .....	36
Table 12.	Parts and Tools for Fixing Mounting Bracket on the Wall.....	37
Table 13.	Parts and Tools for Fixing RRH on the Wall.....	39
Table 14.	Tools for Tilting RRH.....	41
Table 15.	Tools for Swiveling RRH.....	44
Table 16.	Parts and Tools for Fixing Unit Bracket on RRH .....	47
Table 17.	Parts and Tools for Fixing Mounting Bracket on the Pole .....	48
Table 18.	Parts and Tools for Fixing RRH on the 3Sector Pole Type .....	51
Table 19.	Parts and Tools for Fixing Unit Bracket on RRH .....	54
Table 20.	Parts and Tools for Fixing Mounting Bracket on the Pole.....	56
Table 21.	Tools for Fixing RRHs on the Pole.....	59
Table 22.	Parts and Tools for Fixing Unit Bracket on RRH .....	62
Table 23.	Parts and Tools for Fixing Side by Side Bracket on the Pole .....	64
Table 24.	Parts and Tools for Fixing Side by Side Bracket Assembly_Pole Type .....	65
Table 25.	Parts and Tools for fixing RRH_Pole Type Side by Side Installation .....	69
Table 26.	Tools for Marking .....	71
Table 27.	Parts and Tools for Drilling .....	73
Table 28.	Bolt Drill Bits and Hole Depth.....	73
Table 29.	Parts and Tools for Fixing Side by Side Bracket on the Wall .....	74
Table 30.	Parts and Tools for Fixing RRH on the Wall.....	77
Table 31.	Recommended Minimum Allowed Cable bend Radius.....	82
Table 32.	RRH Connection Cable .....	85
Table 33.	RRH Connection Cable .....	86
Table 34.	Parts and Tools for Connecting Ground Cable .....	87
Table 35.	Parts and Tools for Connecting Power Cable .....	93
Table 36.	Parts and Tools for Connecting AC Power Cable.....	96
Table 37.	AC/DC Power Unit AC Power Cable Connector Pin Map.....	96
Table 38.	Parts and Tools for Connecting DC Power Cable.....	99
Table 39.	DC Power Cable/Connector Pin Map .....	100
Table 40.	Parts and Tools for connecting CPRI Cable .....	106
Table 41.	Parts and Tools for Connecting UDA Cable .....	110
Table 42.	UDA Cable Pin Map .....	111
Table 43.	Parts for connecting RET Cable .....	115
Table 44.	RET Cable Pin Map .....	116
Table 45.	RF Cable Minimum Radius of Curvature .....	118
Table 46.	Parts and Tools for connecting RF cable .....	118
Table 47.	Parts and Tools for Assembling Cable Cover .....	124



Table 48.	Construction Situation Checklist .....	127
Table 49.	Standard Torque Value for Fastening Bolts .....	133
Table 50.	Brass Bolts Torque Value.....	133
Table 51.	Connector Connection Torque Value .....	133

# Preface







---

This manual describes how to install the RT4401-48A (CBRS RRH) including how to connect cables. This manual includes the following RRH:

## Conventions in this Document

Samsung Networks product documentation uses the following conventions.

### Symbols

Symbol	Description
	Indicates a task.
	Indicates a shortcut or an alternative method.
	Provides additional information.
	Provides information or instructions that you should follow to avoid service failure or damage to equipment.
	Provides information or instructions that you should follow to avoid personal injury or fatality.
	Provides antistatic precautions that you should observe.

### Menu Commands

**menu | command**

This indicates that you must select a command on a menu, where **menu** is the name of the menu, and **command** is the name of the command on that menu.

### File Names and Paths

These are indicated by a bold typeface. For example:

Copy **filename.ext** into the **/home/folder1/folder2/bin/** folder.

### User Input and Console Screen Output Text

- The input and output text is presented in the Courier New font. For example, `context <designated epc-context-name>`
- The CLI command is presented in capital letters and Courier New, bold style. For example, Type the **RTRV-NE-STS** command in the input field.
- The YANG object is presented in the small letters and boldface. For example, **eutran-cell-conf-idle**

## New and Changed Information

This section describes information that has been added/changed since the previous publication of this manual.

- The 'Installation' section and the 'Power Supply Connection' section of Personal and Product Safety is updated.

## Revision History

The following table lists all versions of this document.

Document Version	Publication Date	Remarks
1.0	January 2019	First version
2.0	January 2019	-
3.0	February 2019	-

## Organization of This Document

Section	Title	Description
Chapter 1	Before Installation	This chapter introduces RRH and describes items should be understood before installation.
Chapter 2	Installing System	This chapter describes the procedures to install the RRH.
Chapter 3	Connecting Cables	This chapter describes the procedures to connect the cables to the RRH installed.
Chapter 4	Inspect the Installation	This chapter describes the procedures of inspecting installation status after RRH installation and cabling is completed.
Appendix A	Acronyms	This annex describes the acronyms used in this manual.
Appendix B	Clean the Optical Connectors	This annex describes the procedure of cleaning the optical connector and cleaning tool.
Appendix C	Standard Torque	This annex describes the standard torque when fastening the bolt.

## Related Documentation

- LTE eNB System Description

## Personal and Product Safety

*This product safety information includes European directives, which you must follow. If these do not apply in your country, please follow similar directives that do apply in your country.*

### Electrical

The product is designed to operate from a -48 V DC supply and is therefore classified as Safe Extra Low Voltage (SELV) equipment.

All structural parts are grounded and all input and outputs have built-in isolation from the network. All input and output ports that connect to external power sources are designed to meet relevant national safety requirements.

The product contains hazardous energy levels as defined by UL 60950. Care must be taken when maintaining this equipment as injury to personnel or damage to the equipment could result from mistakes. Maintenance should only be carried out by trained and competent engineers who are familiar with the relevant procedures and instructions.

### Lasers

The product is fitted with optical modules rated as Class 1 radiation-emitting devices under EN 60825-1. During installation, operation, and maintenance, never look into the end of an optical fiber directly or by reflection either with the naked eye or through an optical instrument. Do not operate equipment with exposed fiber connectors—cover these with fiber cables or blanking caps. Do not remove equipment covers during operation unless requested to do so in the documentation. Carry out normal safety precautions when trimming fibers during installation.

### Manual Handling

Care should be taken when handling equipment. Give due consideration to the weight of the equipment, the physical capability of the individuals handling the equipment, and movements such as twisting, bending and stooping, which could lead to skeletal and muscular injuries.

### Installation

Installation must be carried out by trained and competent engineers only. All relevant safety measures should be taken to ensure equipment is not connected to live power and transmission sources during installation. Equipment must be correctly installed to meet the relevant safety standards and approval conditions.

Each power feed to the unit requires a separate fused feed from the provided power supply. The cable between the power distribution point and the installed equipment must have a minimum cross-sectional area of 2.5 mm<sup>2</sup>.



The CBRS RU product is installed on the Network Telecommunication Facilities.

## Maintenance

Maintenance must only be carried out by a suitably trained and competent technician. All safety instructions must be carefully observed at all times. Equipment covers should not be removed while live power and transmission is connected unless in a controlled environment by trained technicians.

## Fire

The product is powered from a -48 V DC. To protect against fire, the equipment is fused.

## Environment

The product must be operated in an environment with the specified relative humidity and ambient temperature ranges.

Keep all liquids away from the equipment as accidental spillage can cause severe damage.

## Anti-Static Precautions

The circuit boards and other modules in the product are sensitive to and easily damaged by static electricity. If any card or sub-assembly is removed from the unit, the following anti-static precautions must be observed at all times:

- Service personnel must wear anti-static wrist straps.
- Circuit boards and sub-assemblies must be placed on ground conductive mats or in conductive bags.
- All tools must be discharged to ground before use.
- The anti-static wrist strap and cord must be checked at regular intervals for their suitability for use.

## Grounding

To comply with UL 60950, the equipment must be connected to a safety grounding point through a permanent link. Grounding points are located on the product for this purpose. Always connect the ground cable before fitting other cables. The product must remain grounded continuously unless all connections to the power supply and data network are all removed.

If equipment is grounded through a cabinet or rack, make sure it is done so properly.

## Power Supply Connection

Power connections and installation of associated wiring must be carried out by a suitably qualified technician.

Only devices that comply with all relevant national safety requirements should be connected to the unit's power supply inlets. Other usage will invalidate any approval given to this equipment.

Connection of this equipment to devices that are not marked with all relevant national safety requirements may produce hazardous conditions on the network.

When the power supply is obtained by a rectifier/safety isolation transformer, the supply must meet the requirements of UL 60950 providing double/reinforced insulation between hazardous voltages and SELV/TNV circuits. Any battery must be separated from hazardous voltages by reinforced insulation.



The RTN of the CBRS RU is not connected to Grounding.

---

## Indirect Connection

Before indirectly connecting any equipment to another device through a shared power supply, ALWAYS seek advice from a competent engineer.

Devices that are not marked according to the relevant national safety standards may produce hazardous conditions on the network.

## Product Disposal

To reduce the environmental impact of products, Samsung has joined WEEE compliance activities.

The WEEE symbol on the product indicates that the product is covered by the European Directive 2002/96/CE for the disposal of Waste Electrical and Electronic Equipment (WEEE). This means that the product should be disposed of separately from the municipal waste stream through designated collection facilities appointed by the government or the local authorities. This will help prevent potential negative consequences for the environment and human health. Please check the terms and conditions of the purchase contract for information about correct disposal.

## California USA Only

This Perchlorate warning applies only to primary CR (Manganese Dioxide) Lithium coin cells in the product sold or distributed ONLY in California USA

‘Perchlorate Material-special handling may apply, See [www.dtsc.ca.gov/hazardouswaste/perchlorate](http://www.dtsc.ca.gov/hazardouswaste/perchlorate).’

## FCC Statement

This equipment has been tested and found to comply with the limits for a Class A

digital device, pursuant to part 15 of the FCC Rules. These limits are designed to provide reasonable protection against harmful interference when the equipment is operated in a commercial environment. This equipment generates, uses, and can radiate radio frequency energy and, if not installed and used in accordance with the instruction manual, may cause harmful interference to radio communications. Operation of this equipment in a residential area is likely to cause harmful interference in which case the user will be required to correct the interference at his own expense.

Any changes or modifications not expressly approved by the party responsible for compliance could void the user's authority to operate this equipment.

## Equipment Markings



This marking on the product, accessories or literature indicates that the product and its electronic accessories (for example, charger, headset, and USB cable) should not be disposed of with other household waste at the end of their working life. To prevent possible harm to the environment or human health from uncontrolled waste disposal, please separate these items from other types of waste and recycle them responsibly to promote the sustainable reuse of material resources.

Household users should contact either the retailer where they purchased this product, or their local government office, for details of where and how they can take these items for environmentally safe recycling.

Business users should contact their supplier and check the terms and conditions of the purchase contract. This product and its electronic accessories should not be mixed with other commercial wastes for disposal.

**Protective earth**

RRH AC/DC power unit should be grounded.



# Chapter 1 Before Installation

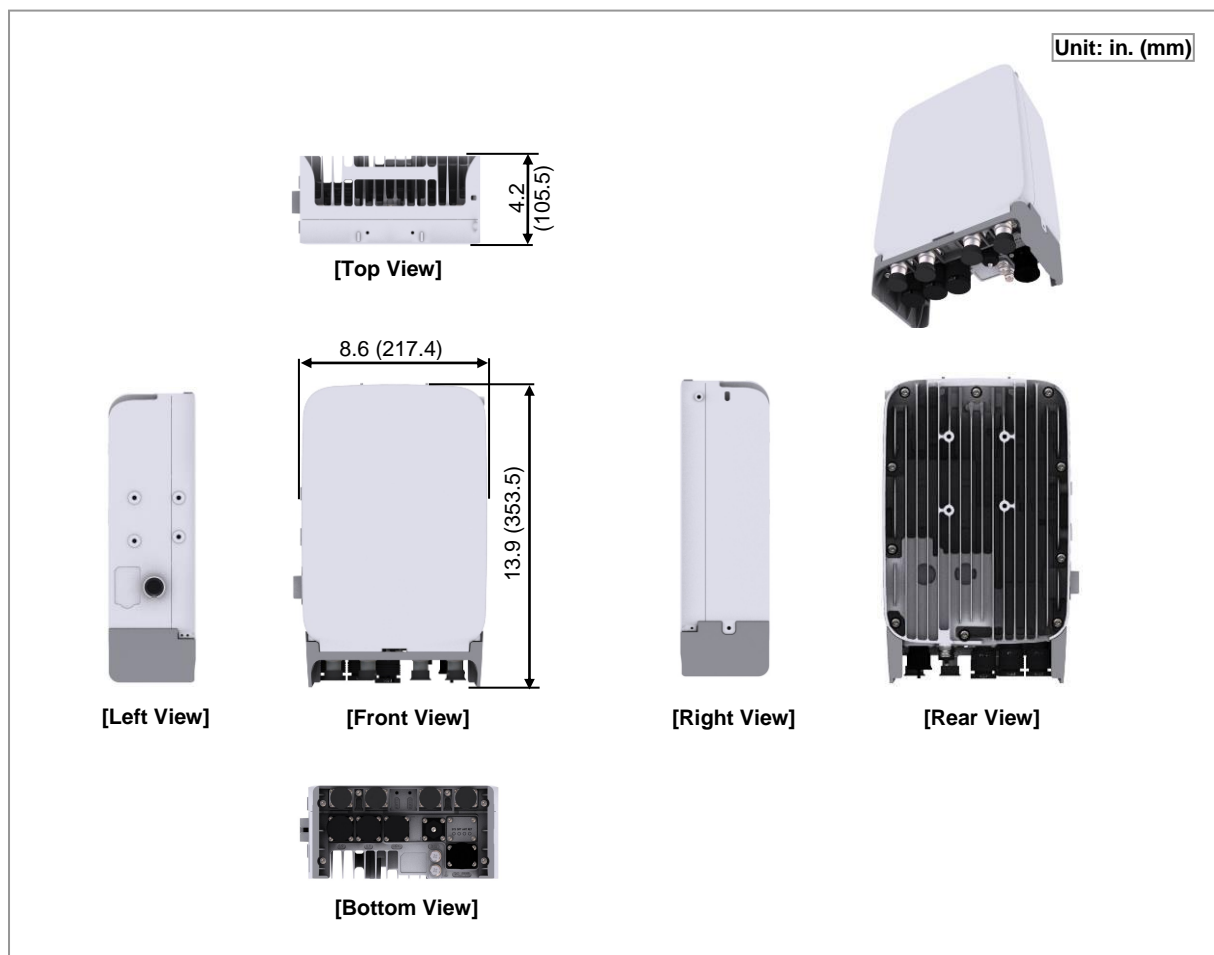
## System View and External Interface

This section provides the physical structure of the RRH system and its interfaces.

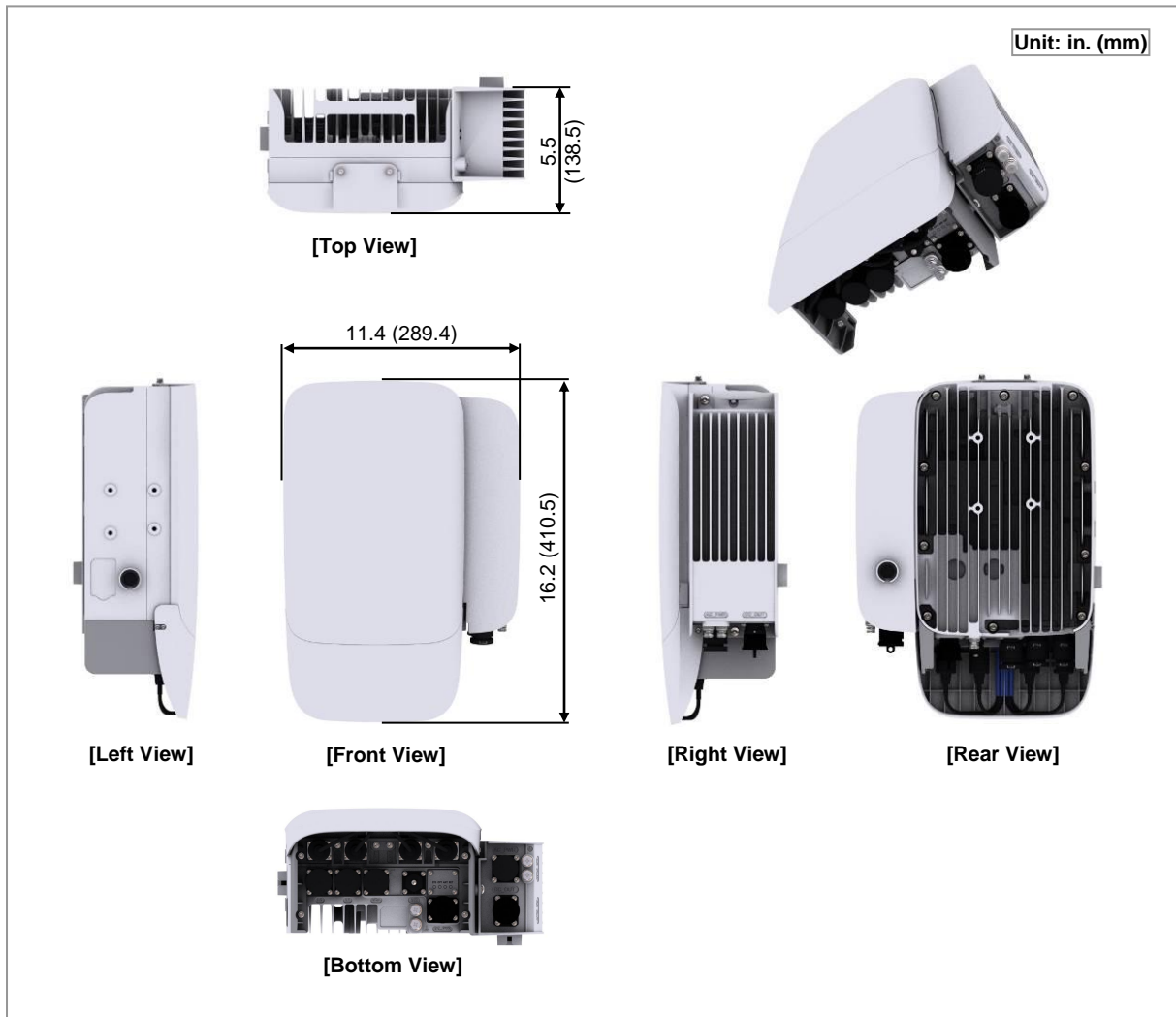
### System View

The figure below depicts the physical structure of the system.

Figure 1. System View (RRH only)



*Figure 2. System View (with Clip-on: Antenna + AC-DC Power Unit)*



## System External Interface

The figure below depicts the external interface structure of the RRH system.

Figure 3. System External Interface (RRH only)

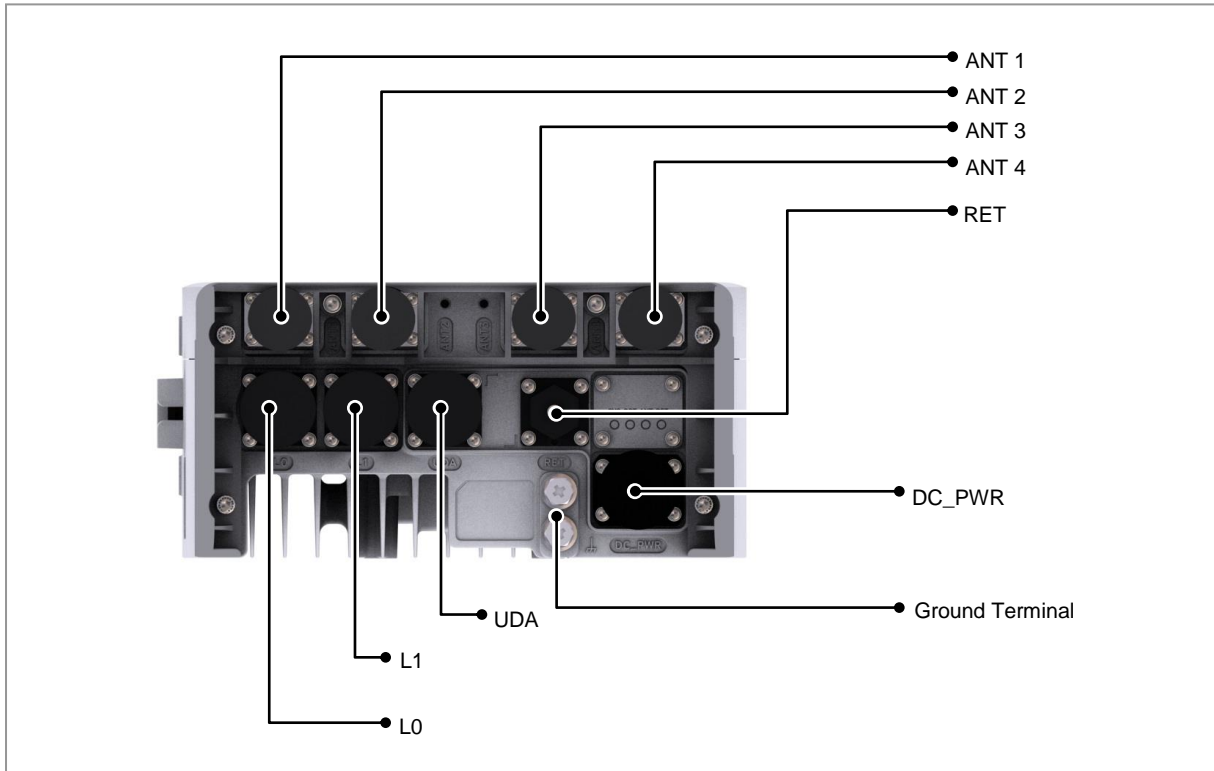
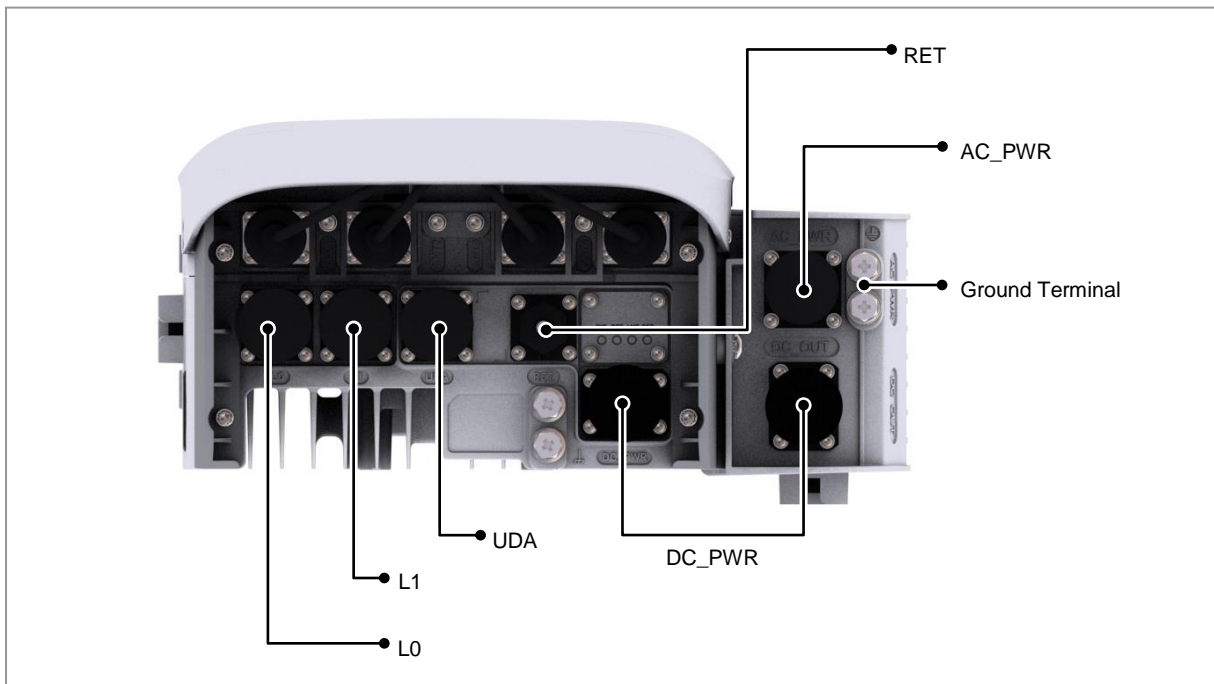
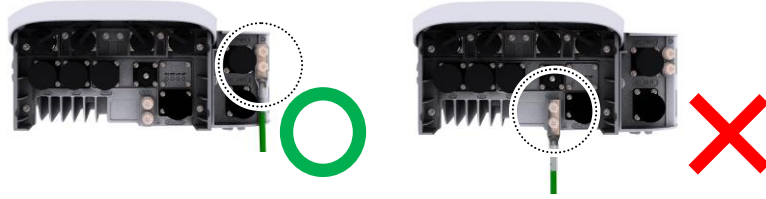


Figure 4. System External Interface (with Clip-on: Antenna + AC-DC Power Unit)





When interoperating the AC-DC power unit, the ground cable must be connected to the ground terminal of the AC-DC power unit.



# Specifications

The table below outlines the main specifications of the RRH.

**Table 1. Specifications**

Item	RT4401-48A
Air Technology	LTE
Band	Band 48 (3.5 GHz)
Operating Frequency (MHz)	3550 to 3700
RF Chain	4TX/4RX
Input Power	-48 V DC (-38 to -57 V DC, 1 SKU), with clip-on AC-DC converter (Option)
Dimension (W x D x H) (mm)	8.55 in. (217.4) x 4.15 in. (105.5) x 13.91 in. (353.5) * RRH only 11.39 in. (289.4) x 5.45 in. (138.5) x 16.16 in. (410.5) * with Clip-on antenna, AC-DC power unit
Cooling	Natural convection
Unwanted Emission	3GPP 36.104 Category A [B48]: FCC 47 CFR 96.41 e)
Spectrum Analyzer	TX/RX Support
Antenna Type	Integrated (Clip-on) antenna (Option), External antenna (Option)
Operating Humidity	5 to 100 [%] (RH), condensing, not to exceed 30 g/m <sup>3</sup> absolute humidity
Altitude	-60 to 1,800 m
Earthquake	Telcordia Earthquake Risk Zone4 (Telcordia GR-63-CORE)
Vibration in Use Transportation Vibration	Office Vibration Transportation Vibration
Noise	Fanless (natural convection cooling)
Wind Resistance	Telcordia GR-487-CORE, Section 3.34
EMC	FCC Title 47, CFR Part 96
Safety	UL 60950-1 2nd ED

<b>Item</b>	<b>RT4401-48A</b>
	UL 62368-1 UL 60950-22
RF	FCC Title 47, CFR Part 96

The table below outlines the AC/DC power unit specifications of the RRH system.

## Cautions for Installation

Observe the safety instructions described in this section when installing the system. Installation should be done in accordance with the applicable local electric codes.

### Before Installing

Before starting the installation, ensure the following:

- Post warning signs in areas where high-voltage cables are installed.
- Post “off limit” signs in areas where accidents are most expected.
- Use guardrails or fences to block open areas such as ditches, open roof areas, and scaffolds.



Install the system in the restricted access area.

---

### While Installing

During installation, ensure the following:

The system power must be cut off before installing.



Ensure that the power switch of the power supply is off when installing the system. Installing the system with power on may cause system damage or fatal human injury when connecting or disconnecting cables.



Ensure that workers wear protection gloves and goggles to prevent injury from debris while drilling holes in a wall or ceiling.



Do not wear accessories such as watches and rings to prevent electrical shock.



When using the AC / DC converter, connect the DC power cable first before connecting the AC power.

---



Cover unused ports with a cap. This prevents foreign substances from entering into the unused ports.



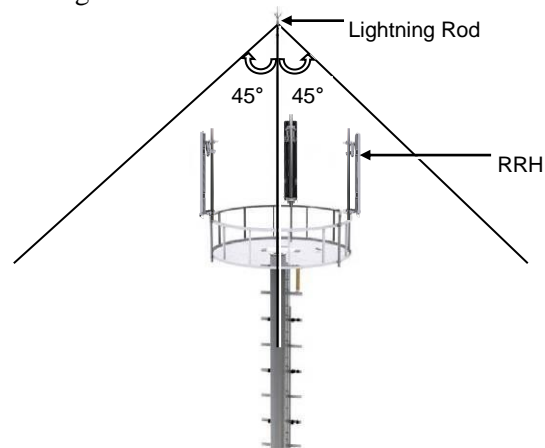
To prevent foreign substances, outdoor air, and moisture from entering the cable inlet (including cable gland and conduit), finish the inlet as follows:

- Unused inlet: Use the hole finishing materials including cap and rubber packing.
- Cable-installed inlet: After cable installation, block any space in the inlet with tape, compressed sponge, rubber packing, and silicone.



When operator installs the RRH, the RRH must be within the protective angle (left/right side 45° each from the central axis) to prevent the RRH from lightning

damage.



## After Installing

After installation, remove any debris produced during the work and clean up the installation site.



In the system, the laser beam light runs through the optical cable. The workers must handle the optical cables with care as the laser beam can seriously damage the eyes.



When using the AC / DC converter, if servicing of the RRU is required, disconnect the AC power first.



Ensure that the workers do not damage installed cables while cleaning the system.












While cleaning the power supply device, take precaution that the device does not come in contact with foreign objects that may cause power failure.















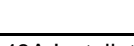









# Installation Tools

The basic tools required for installation are listed in the table below. The additional tools required for each site need to be identified and arranged during a site survey before starting the installation.

**Table 3. Basic Installation Tools**

No.	Name	Specification	Purpose of use
1	 Torque Driver	Apply a torque range : 20 to 90 lbf-in	Fastening M6 SEMS
		Apply a torque range : 6 to 22 lbf-in	Fastening M3, M4 Torx screw
2	 Screw Driver Bit	'+', No. 3	Fastening M6 SEMS
3	 Screw Driver	'+', No. 3	Loosening M6 SEMS
4	 Torx Screw Driver	(T10H/T2H/T25H)	Loosening Torx screw
5	 Torx Driver Bit	T10H	Fastening Torx screw (T10H)
		T20H	Fastening Torx screw (T20H)
		T25H	Fastening Torx screw (T25H)
6	 Torque Wrench	Apply a torque range : 10 to 50 lbf-in	Tightening M6 Hexagonal. bolt
		Apply a torque range : 100 to 400 lbf-in	Tightening M10, M12 hexagonal. bolt
7	 Torque Wrench Spanner Head	Apply hexagonal.bolt head: 10 mm (for 10 to 50 lbf-in)	Tightening M6 hexagonal.bolt
		Apply hexagonal. bolt head: 13 mm (for 100 to 400 lbf-in)	Tightening M8 hexagonal.bolt
		Apply hexagonal.bolt head: 17 mm (for 100 to 400 lbf-in)	Tightening M10 hexagonal.nut
		Apply hexagonal.bolt head: 19 mm (for 100 to 400 lbf-in)	Tightening M12 hexagonal.nut
8	 Spanner	10 mm	Tightening M6 hexagonal. bolt
		13 mm	Tightening M8 hexagonal. bolt
		17 mm	Tightening M10 hexagonal. bolt
		19 mm	Tightening M12 hexagonal. bolt
9	 Mini DIN Male Torque Wrench	TQ-78-F8	Tightening 4.3-10 and mini din connector
10	Tape Measure	16 ft./150 ft.	Measuring length

No.	Name	Specification	Purpose of use
			
11	Level 	Normal	Levelling horizontality and verticality
12	Power Extension Cable 	100 ft.	Basic tool
13	Hammer Drill 	Normal	Wall type drilling
14	Optical Connector Cleaner 	For LC Connector	Cleaning optical connector
15	Concrete Drill Bit 	14 mm	Setting M10 anchor
16	Anchor Punch (Set) 	M10	Setting M10 anchor
17	Hammer 	Normal	Fixing anchor
18	Vacuum Cleaner 	Normal	Removing dust during the drilling work
19	Cable Cutter 	0.24-1.26 in. (6-32 mm)	Cutting cable
20	Crimping Tool 	14 AWG-4 AWG (1.5 to 16 mm <sup>2</sup> )	Crimping pressure terminal
21	Cable Stripper 	Apply cable thickness: 1.5 to 6.2 in. (4 to 16 mm)	Removing cable sheath
22	Nipper 	Basic Tool	Cutting cable
23	Flush cutter 	Basic Tool	For cutting cable tie
24	Industrial Scissor 	Basic Tool	Cutting

No.	Name	Specification	Purpose of use
			
25	Knife 	Basic Tool	Cutting
26	Heating Gun 	50°C to 300°C	Shrinking the feeder cable tube
27	Multi tester 	Digital Pocket Tester	Checking voltage and current to detect cable disconnection
28	Angle Meter 	Normal	Checking RRH tilting
29	Fiber Optical Test Set 	Wave length: 1270 nm, 1310 nm, 1550 nm (single-mode) 850 nm, 1310 nm (multi-mode)	Checking optical level
30	RF Alignment Tool 	-	Checking azimuth and tilting



The required installation tools may vary depending on the site conditions. In addition to the basic tools, protractor, ladder, safety equipment, and cleaning tools must also be arranged, considering the site conditions.

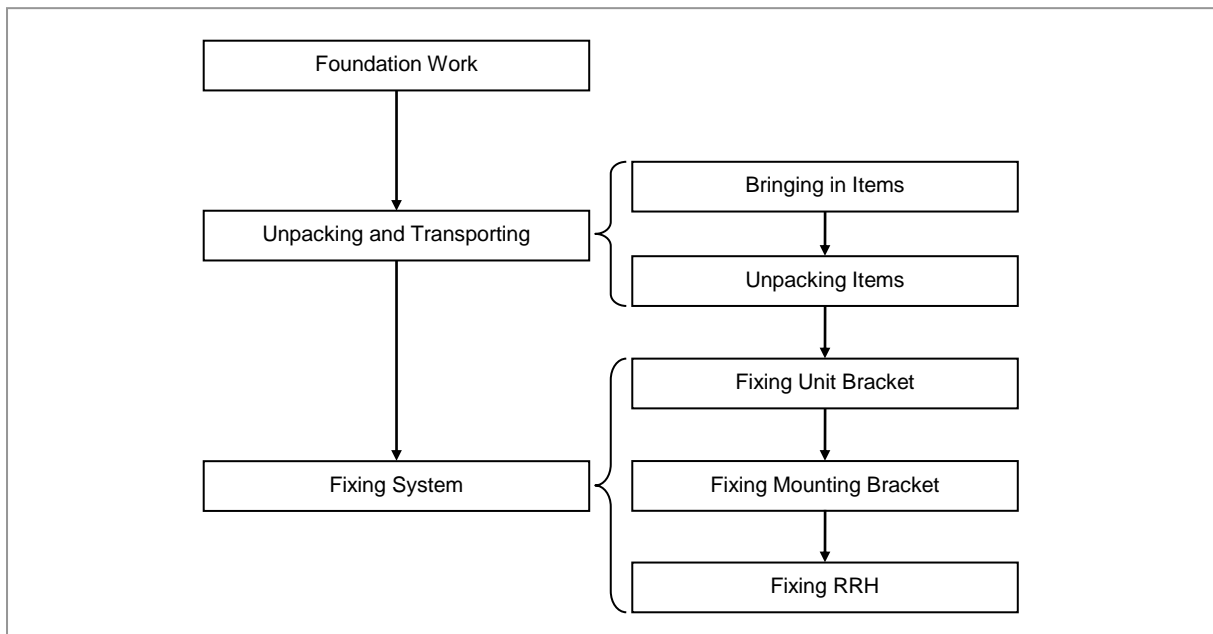
# Chapter 2 Installing System

This chapter describes the installation procedures of the RRH.

## Installation Procedure

The figure below depicts the overall procedures for installing the RRH:

Figure 5. Procedure to Install the RRH



Ensure that the power switch of the power supply is OFF when installing the system. Installing the system with the power switch ON may cause system damage or fatal human injury when connecting or disconnecting the cables.



To prevent the risk of electrical shock, do not wear accessories such as watches and rings.

# System Arrangement

A minimum distance must be secured around the RRH, in each direction for installation and maintenance.



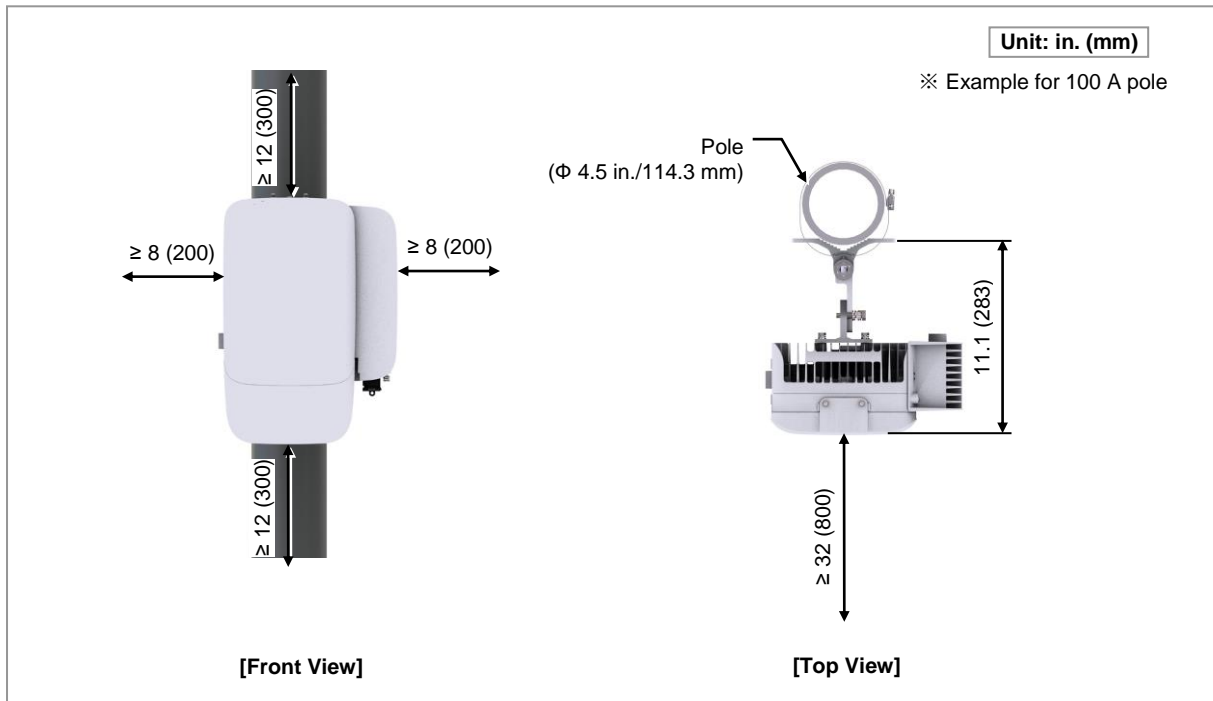
The recommended clearance for installing the RRH is as follows.

Category	Recommended Distances	Remarks
Front	≥ 32 in. (800 mm)	-
Sides	≥ 8 in. (200 mm)	Standard Installation
Top	≥ 12 in. (300 mm)	-
Bottom	≥ 12 in. (300 mm)	Over the air, without cover
	≥ 16 in. (400 mm)	Over the ground, without cover

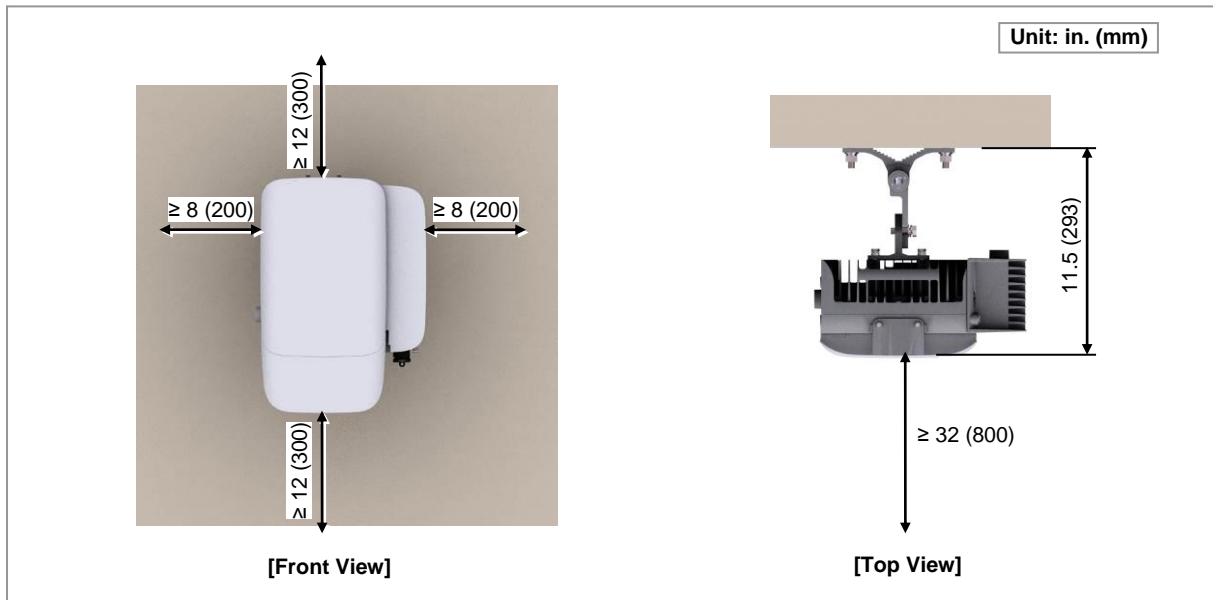
## Using Tilting and Swiveling Bracket

The figures below depict the recommended distances for each direction of the RRH using the tilting and swiveling bracket for the wall and the pole type installations.

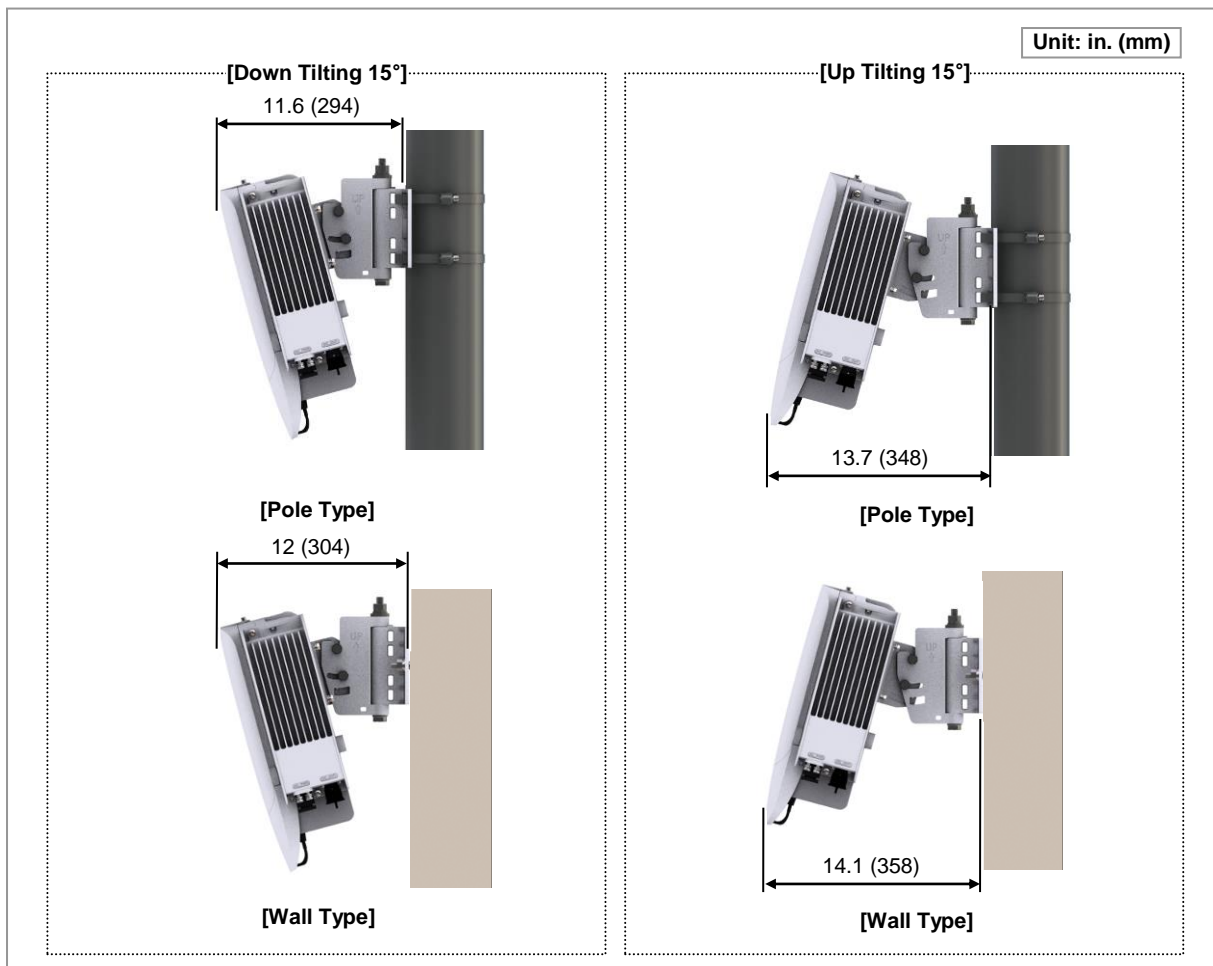
Figure 6. RRH Arrangement\_1 Sector Pole Type Installation



*Figure 7. RRH Arrangement\_1 Sector Wall Type Installation*



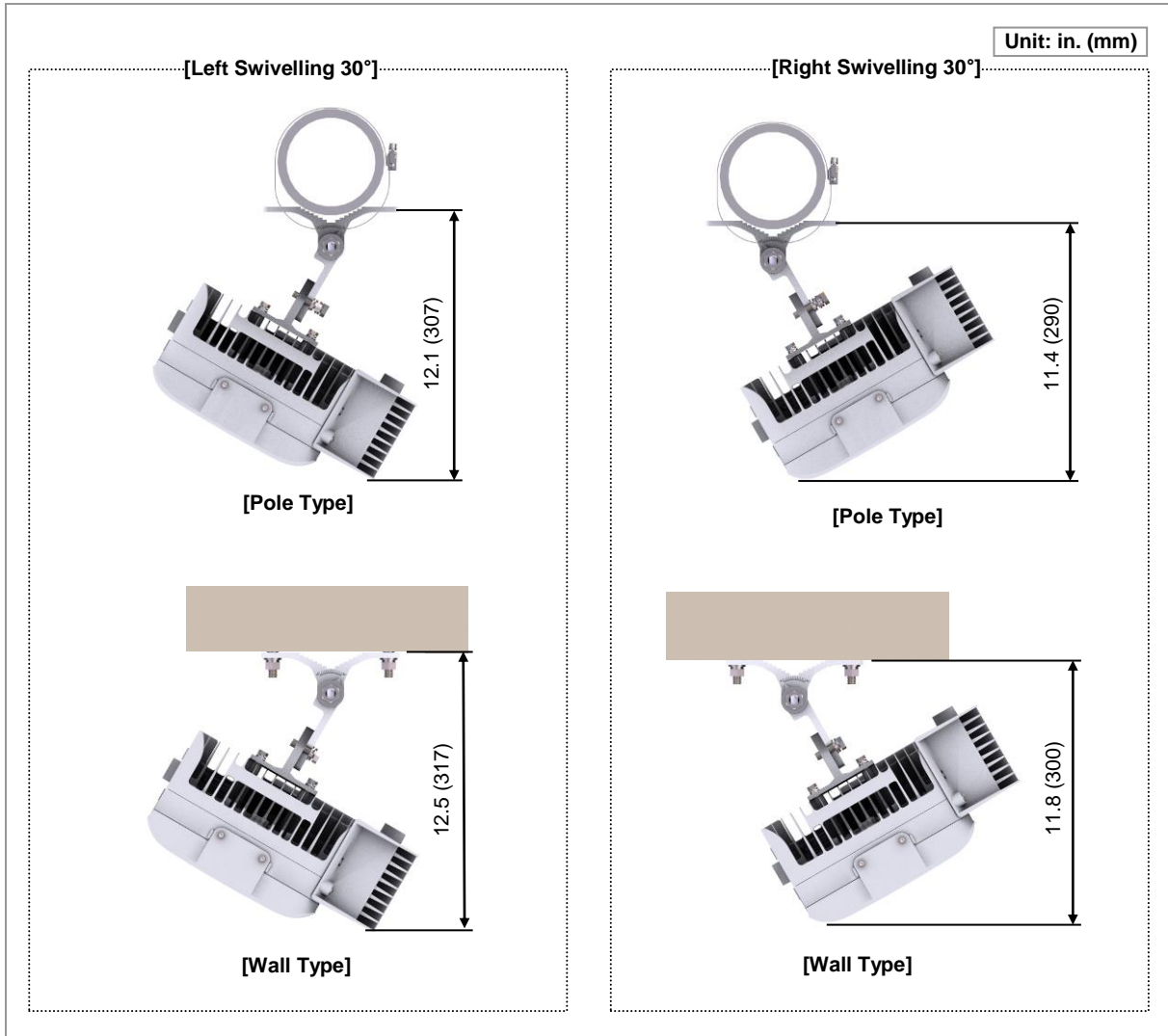
*Figure 8. RRH Arrangement\_1 Sector Tilting*





The dimensions of the RRH change according to the tilt angle, and the maximum dimensions are described in the figure above (RRH Arrangement\_Down, Up Tilting 15°).

**Figure 9. RRH Arrangement\_Swivelling**

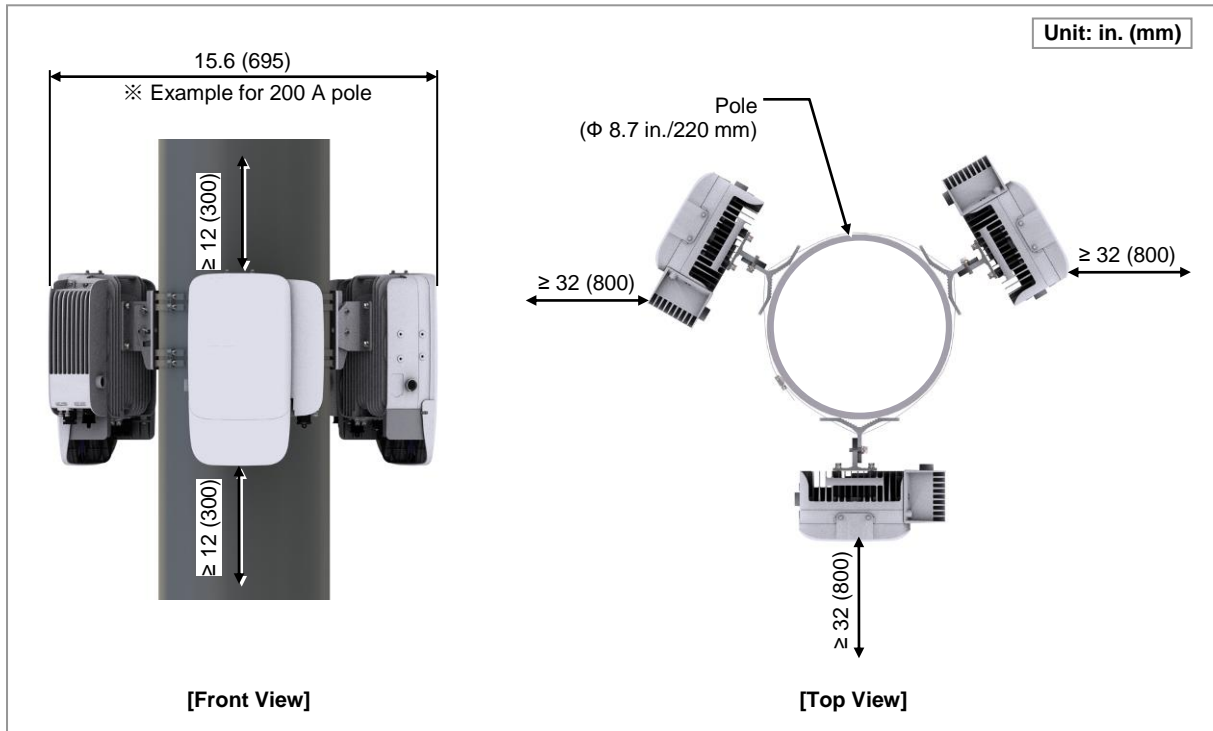


The dimensions of the front of the RRH change according to the tilt angle, and the maximum dimensions are described in the figure above. (RRH Arrangement\_Left, Right Swivelling 30°).

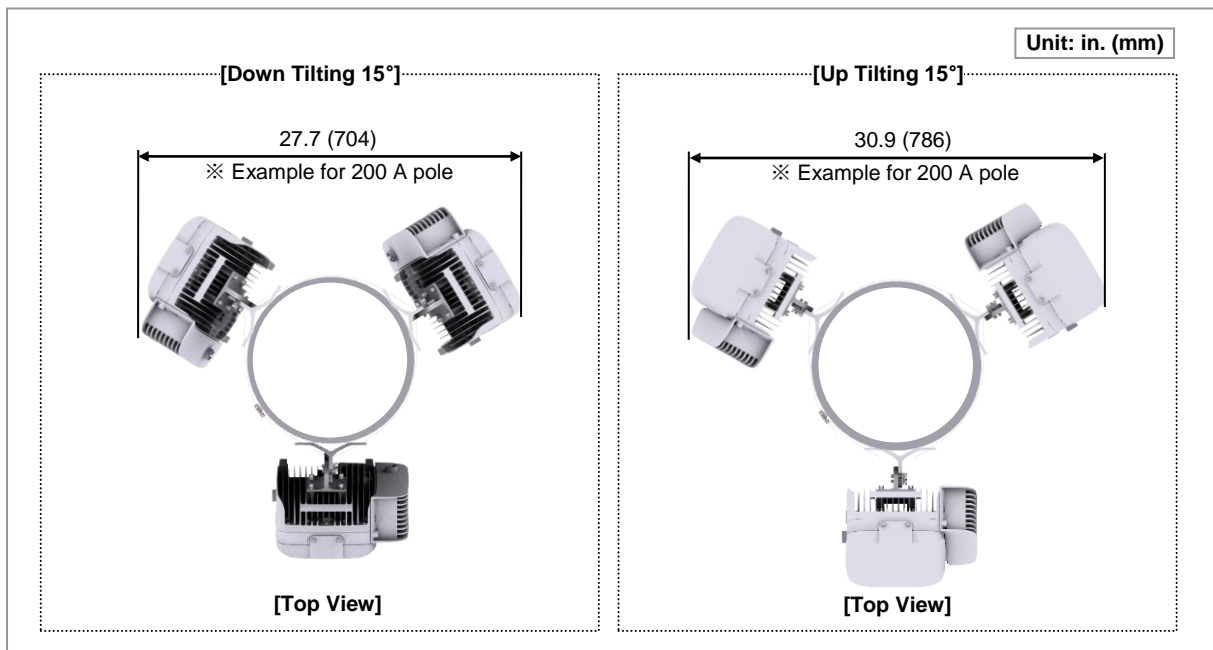
## Using Tilting Bracket

The figures below depict the recommended distances for each direction of the RRH using the tilting bracket for the pole type installation.

**Figure 10. RRH Arrangement\_3 Sector Pole Type Installation**



**Figure 11. RRH Arrangement\_3 Sector Tilting**





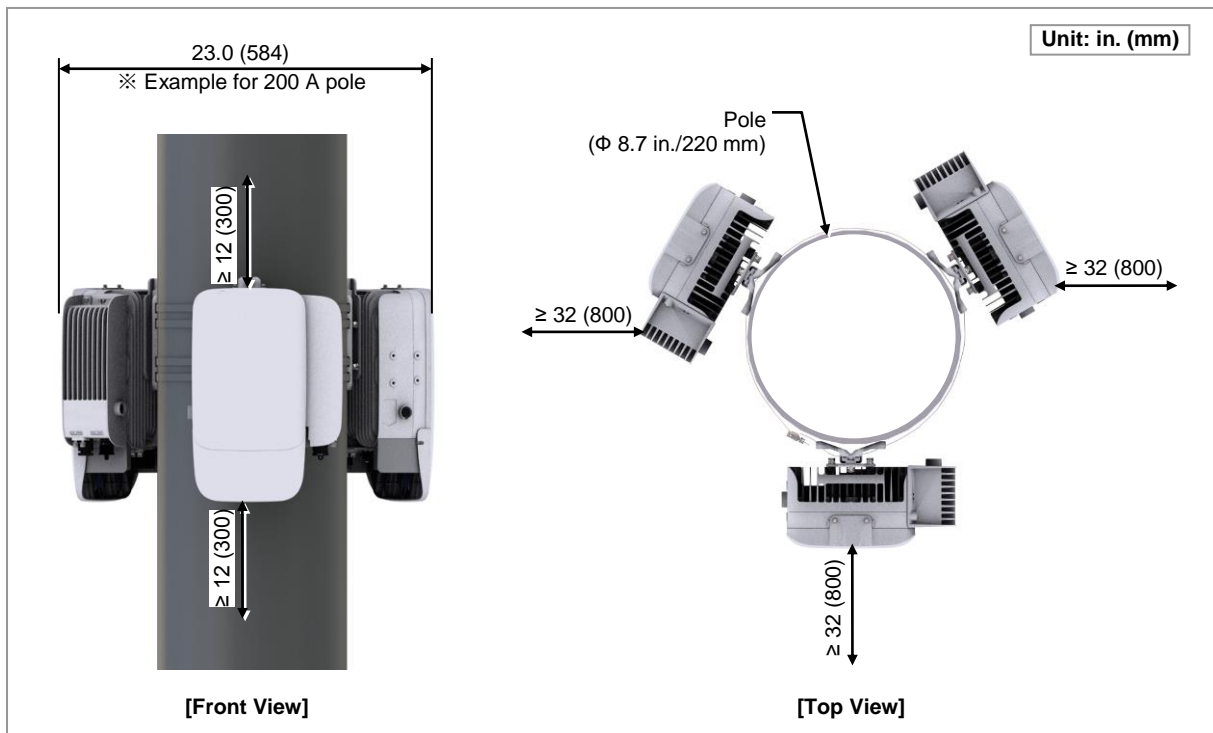


The dimensions of the RRH change according to the tilt angle, and the maximum dimensions are described in the figure above (RRH Arrangement\_Down, Up Tilting 15°).

### Without Tilting Bracket

The figures below depict the recommended distances for each direction of the RRH without using the tilting bracket.

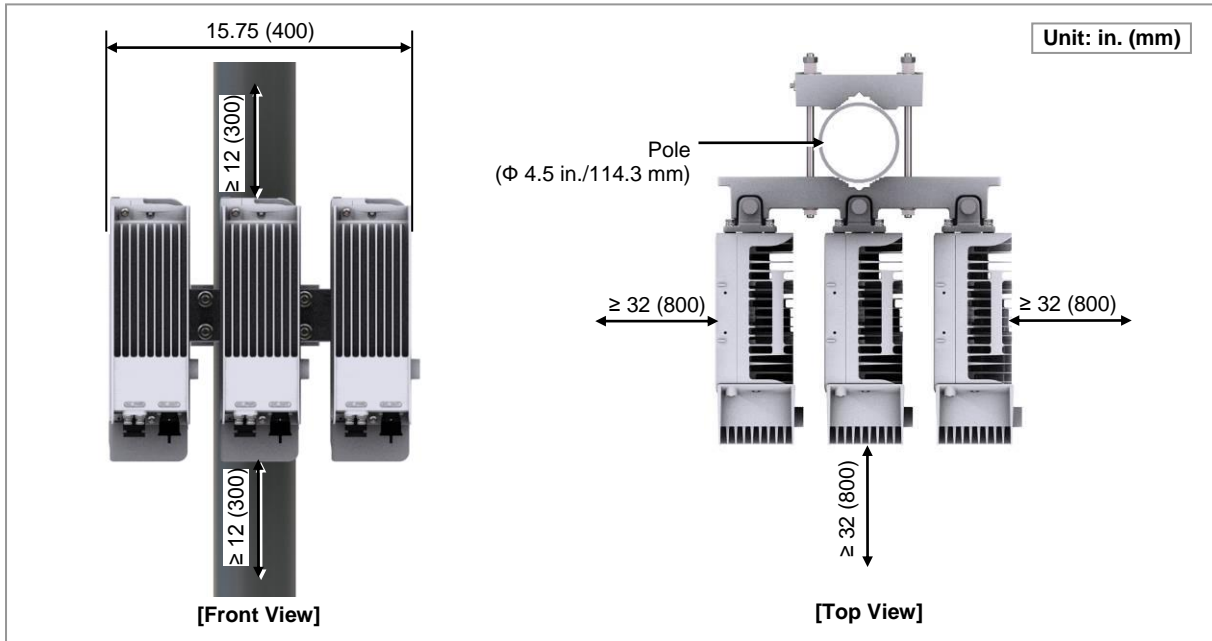
**Figure 12. RRH Arrangement\_3 Sector Pole Type Installation**



### Using Side by Side Bracket

The figures below depict the recommended distances for each direction of the RRH using the side by side bracket for the pole type installation.

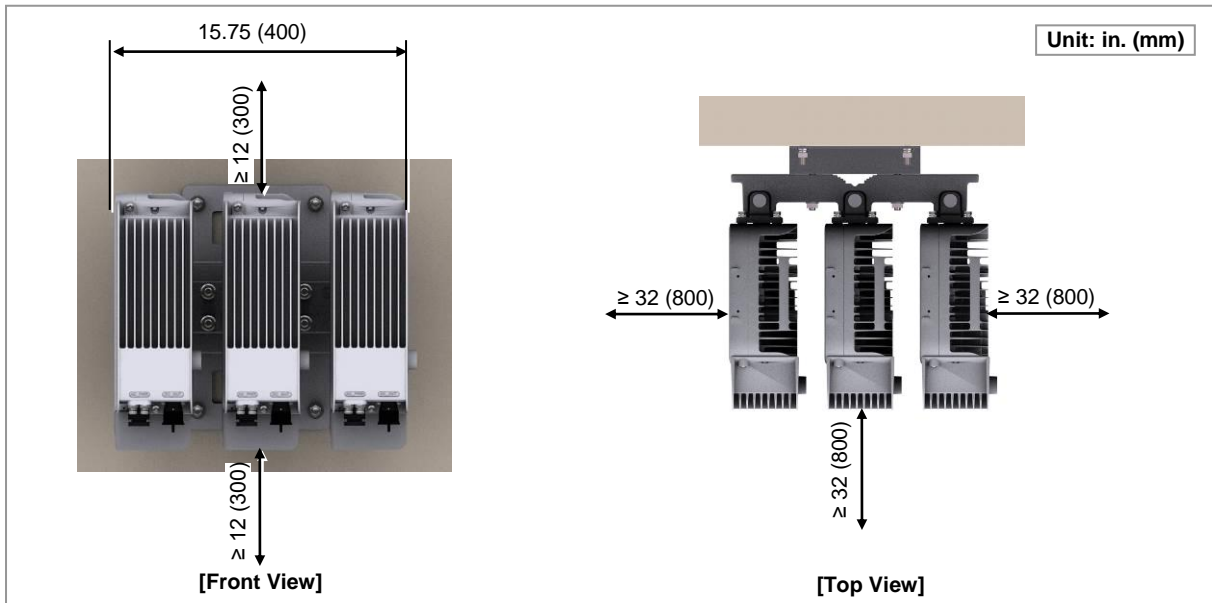
**Figure 13. RRH Arrangement\_3 Sector Pole Type Side by Side Installation**



When fixing a mounting bracket, the length of stud bolts are 8.7 in. (220 mm) for the pole diameter of 50 to 100 A.

Pole Size (Diameter)	Length of Stud Bolt
50 A to 100 A	8.7 in. (220 mm)

**Figure 14. RRH Arrangement\_3 Sector Wall Type Side by Side Installation**



## Transporting and Unpacking

This section describes how to transport the items to the installation place and provides the procedure to unpack cabinets and other components.

### Bringing in Items

Ensure the following at each stage of transportation of the items:

- Before moving a system, check storage place for the system and remove obstacles in advance.
- When carrying the system:
  - Fasten the system firmly to the transport vehicle or carrier to prevent damage to the system from a vibration or shock.
  - Use an elevator to prevent accidents. However, if the system must be carried by people, ensure there are enough people to carry the system.
- The system must not be shocked physically.
- The system should be protected from dust, moisture, and static electricity.

### Unpacking

To unpack the items, ensure the following:

- The items must be packed until they reach the installation place.
- The items are classified in accordance with each job specification and stored at a place that does not interfere with working.
- Unpacked systems must be installed immediately. If immediate installation of the systems is not planned, the systems must be stored in the installation place temporarily.
- Unpack only external packing, leaving the internal packing in unpacked status.
- Unpack the inner packaging after each system is placed on its installation location.
- Dispose by-products (packaging waste) in accordance with waste management rules. Do not recycle the by-products.

# Fixing RRH

This section describes the procedures to fix the RRH with different methods.

## Assembling Clip on Antenna

This section describes the procedure to fix the clip on antenna on the RRH.

### Assembling Clip on Antenna

To fix the clip on antenna, do the following:

#### Prerequisites

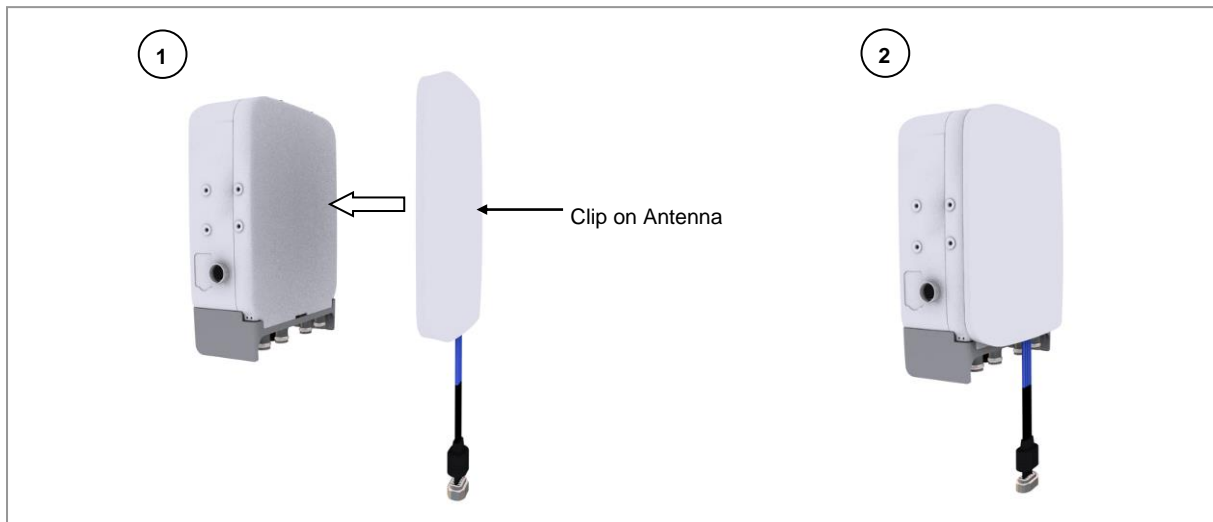
Before proceeding with assembling the clip on antenna, make sure that you have the items mentioned in the table below.

**Table 4. Parts and Tools for Assembling Clip on Antenna on RRH**

Category	Description		
Parts	Clip on Antenna		1 EA
	Fasteners	M4 x L10 Torx Screw	4 EA
Recommended Torque Value	M4 Torx Screw		13 lbf-in
	4.3-10 (Plus) Male Connector		44 lbf-in
Working Tools	<ul style="list-style-type: none"> <li>• Torque Wrench (10 to 50 lbf-in)</li> <li>• Torque Driver (6 to 22 lbf-in)</li> <li>• Screw Driver Bit (T20H)</li> <li>• Torque Wrench Spanner Head (apply Hex. head: 22 mm)</li> </ul>		

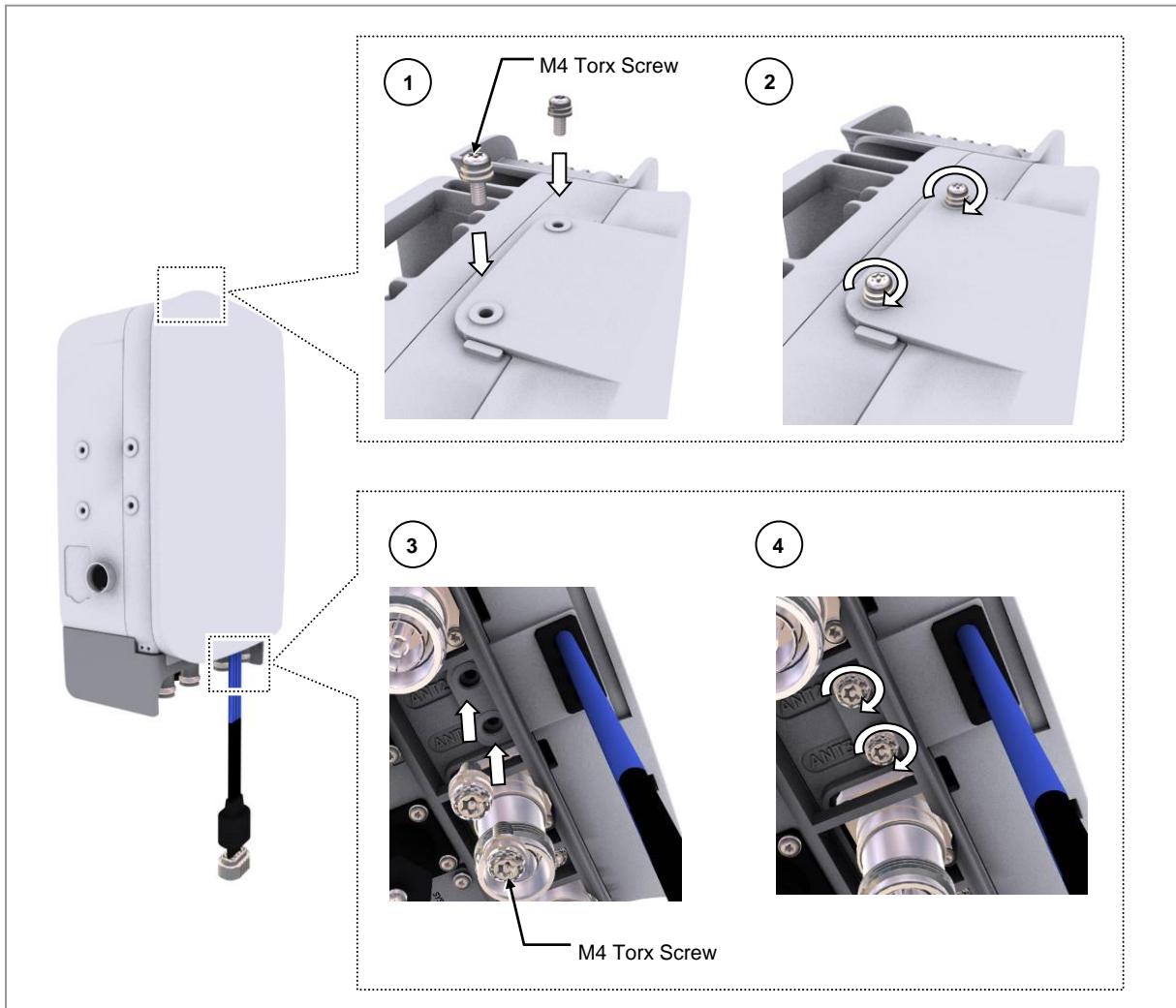
- 1 Check the position for mounting the clip on antenna on the front of the RRH and place it in that position.

**Figure 15. Assembling Clip on Antenna (1)**



2 Fix the clip on antenna using the fasteners.

Figure 16. Assembling Clip on Antenna (2)



3 Insert port seal into RRH ANT 1, 2, 3, 4 port.



When inserting the port seal to RRH ANT port, take care of the direction.

- The screw thread of port seal should be downwards.

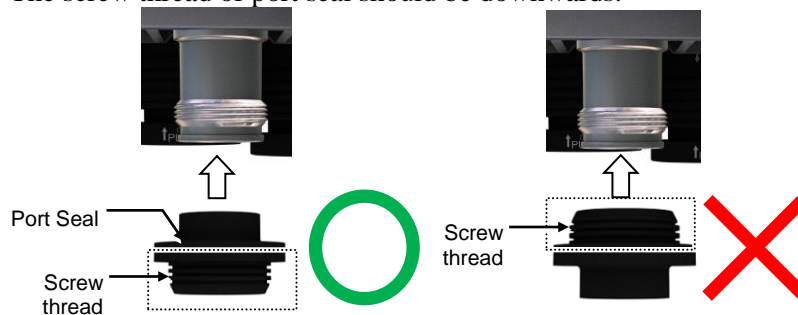
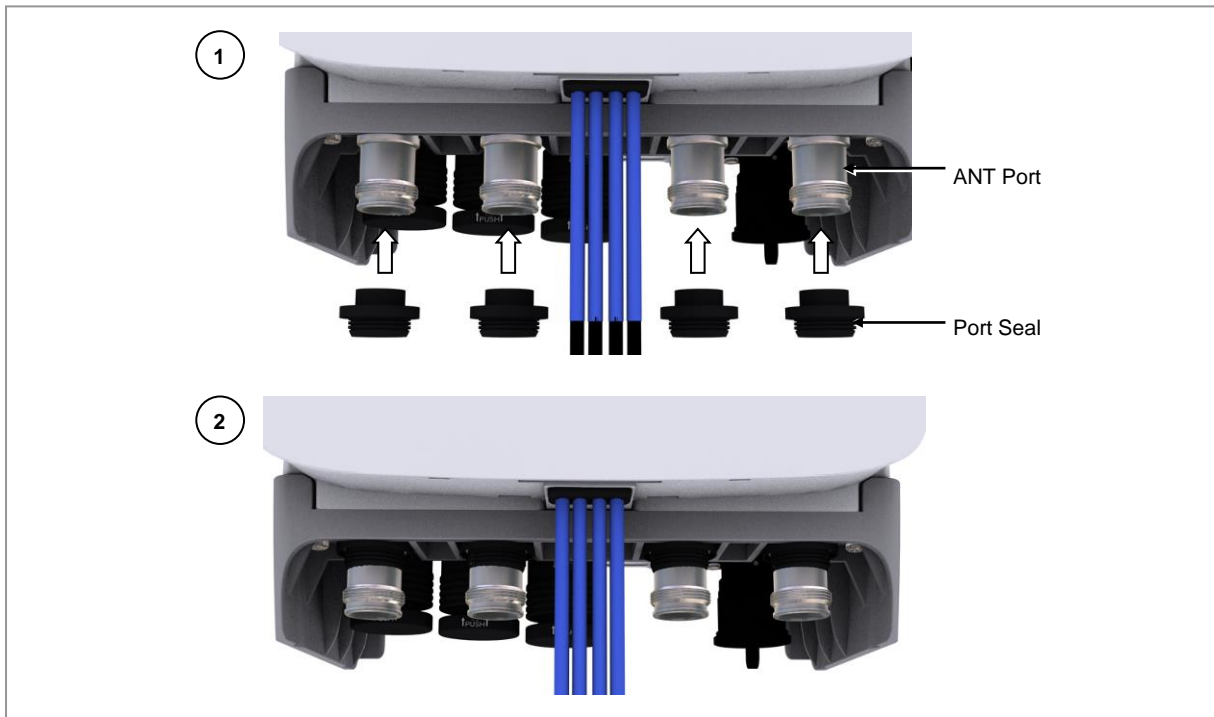
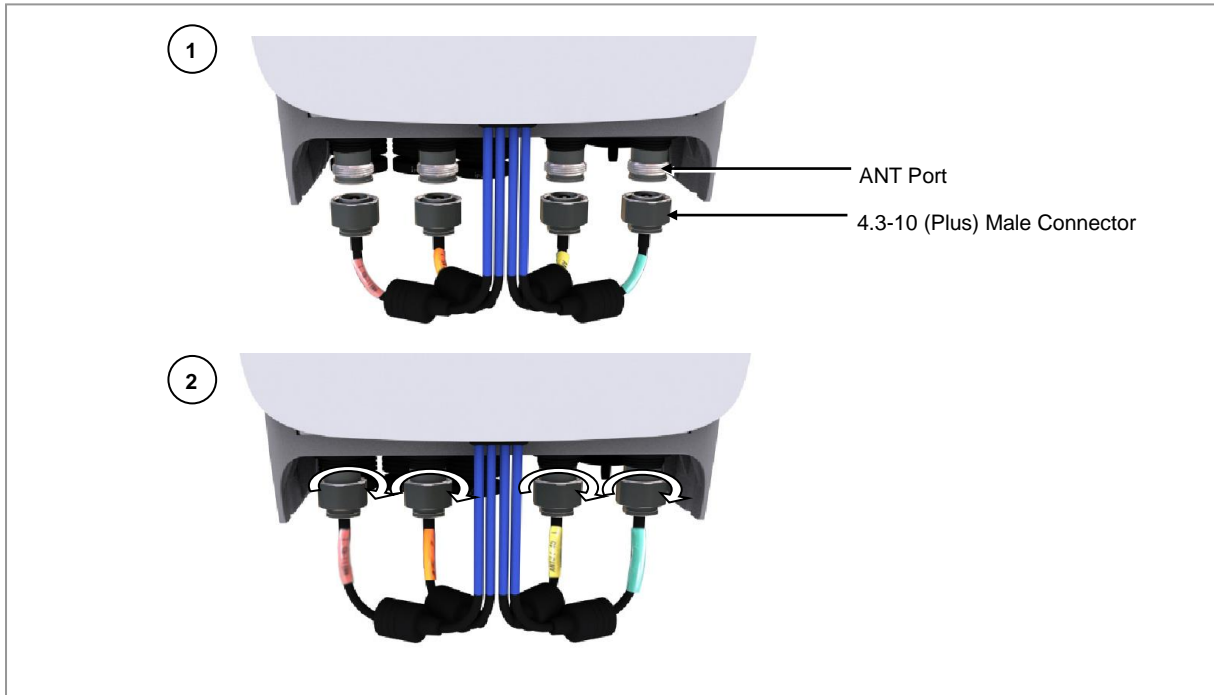


Figure 17. Assembling Clip on Antenna (3)

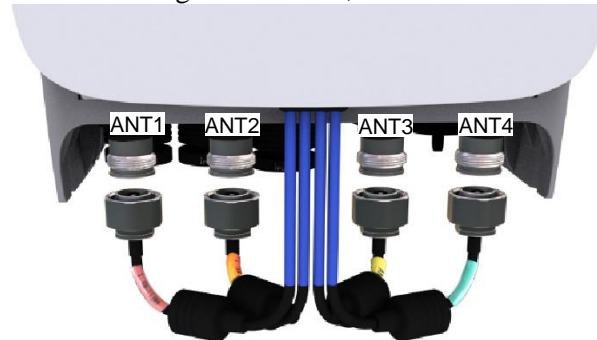


**4** Connect the RF connector of clip on antenna to the RRH ANT 1, 2, 3, 4 port.

Figure 18. Assembling Clip on Antenna (4)



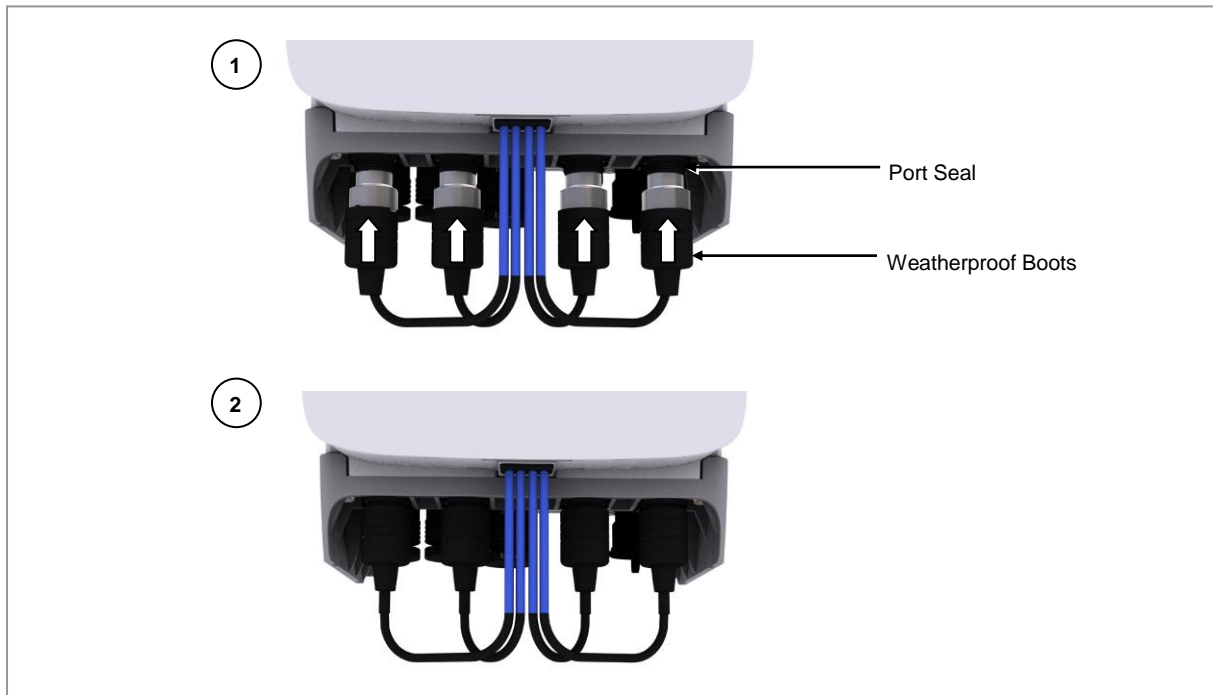
When connecting the RF cable, check the color of the tags on the side of RF cable.



RF Port	Tag Color
ANT1	RED
ANT2	Orange
ANT3	Yellow
ANT4	Aqua blue

**5** Push weatherproof boots up to the port seal.

Figure 19. Assembling Clip on Antenna (5)



## Assembling AC-DC Power Unit

This section describes the procedure to fix the AC-DC power unit on the RRH.

### Assembling Clip on Antenna

To fix the AC-DC power unit, do the following:

#### Prerequisites

Before proceeding with assembling the AC-DC power unit make sure that you have the items mentioned in the table below.

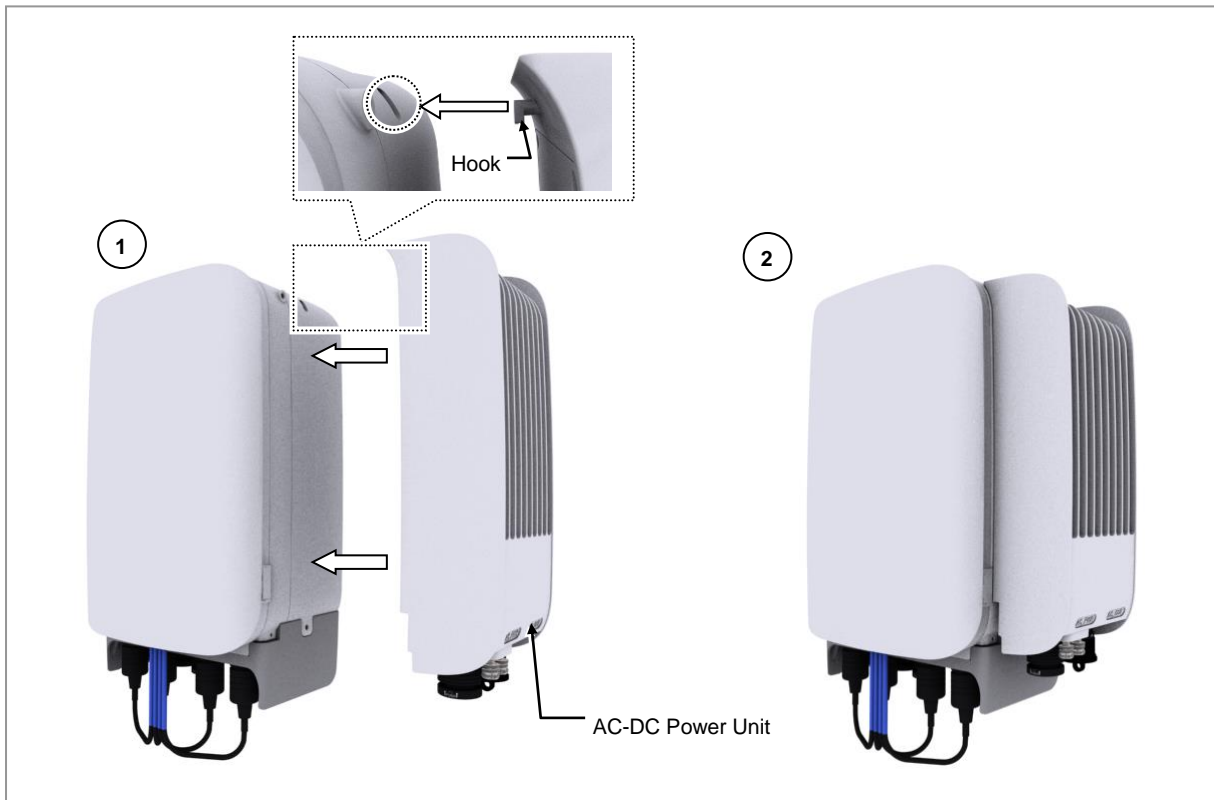
Table 5. Parts and Tools for Assembling AC-DC Power Unit on RRH

Category	Description		
Parts	AC-DC Power Unit		1 EA
	Fasteners	M5 × L16 Torx Screw	2 EA
Recommended Torque Value	M5 Torx Screw		25 lbf-in
Working Tools	<ul style="list-style-type: none"> <li>• Torque Driver (20 to 90 lbf-in)</li> <li>• Screw Driver Bit (T25H)</li> </ul>		

- 1 Place an AC-DC power unit to the right side of the RRH.

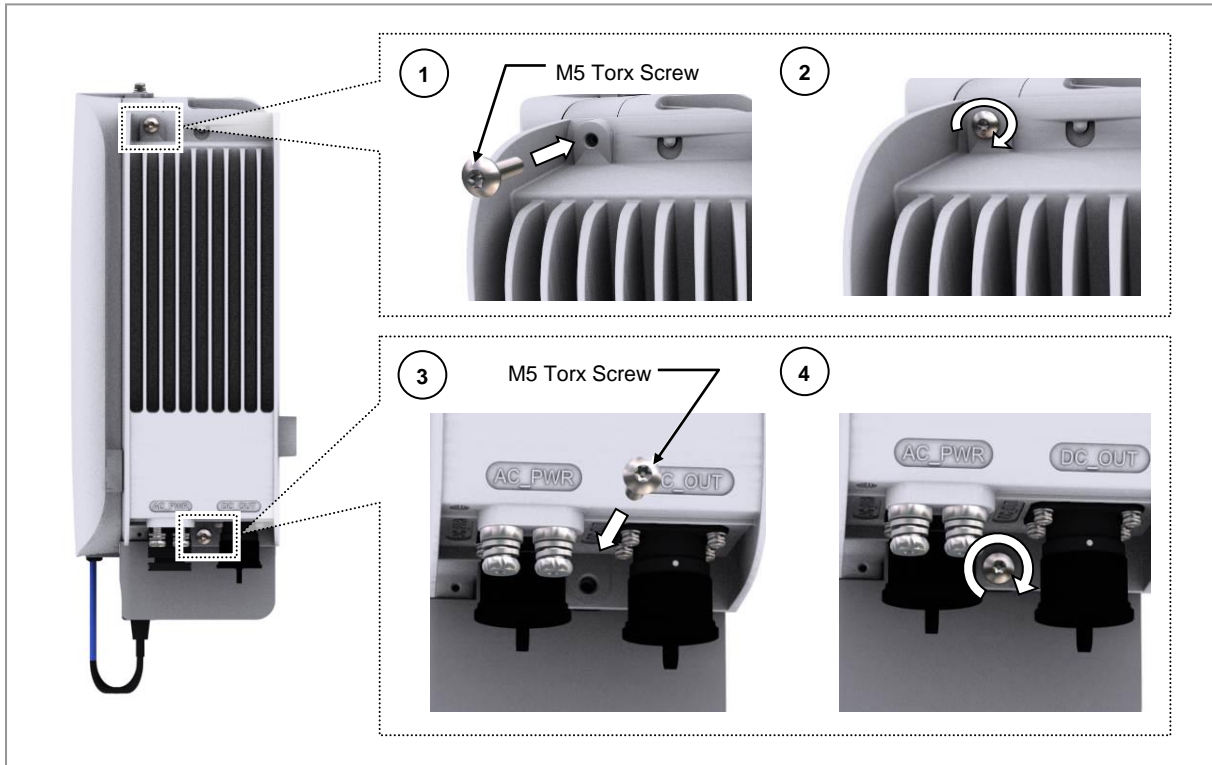


Figure 20. Assembling AC-DC Power Unit (1)



2 Fix the AC-DC power unit using the fasteners.

Figure 21. Assembling AC-DC Power Unit (2)



## Using Tilting and Swiveling Bracket

This section describes the procedure to fix the unit bracket using the tilting and swiveling bracket.

### Fixing Unit Bracket

To fix the unit bracket, do the following:

#### Prerequisites

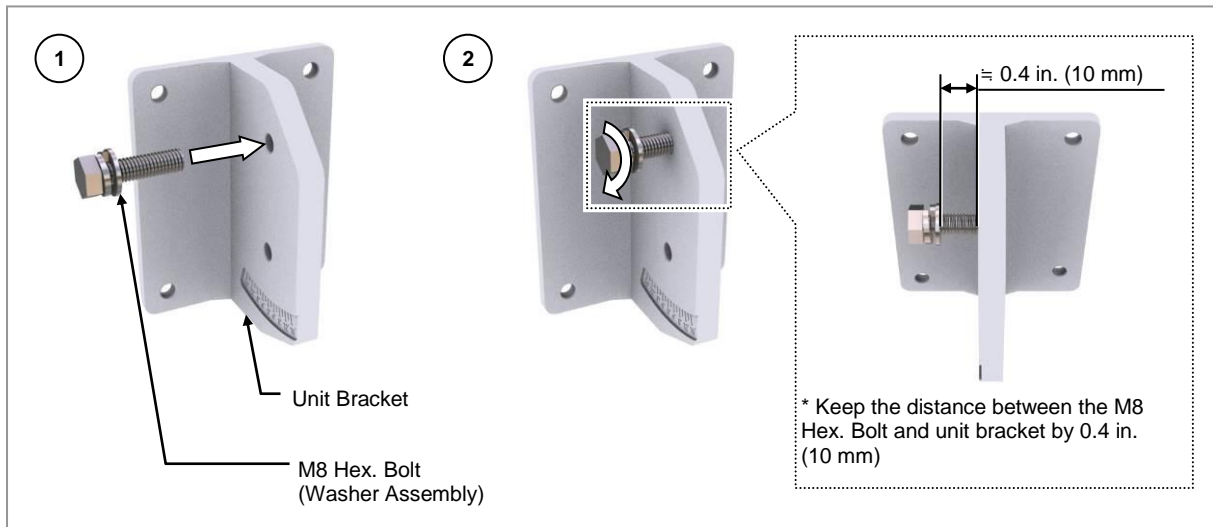
Before proceeding with fixing the unit bracket, make sure that you have the items mentioned in the table below:

Table 6. Parts and Tools for Fixing Unit Bracket on RRH

Category	Description		
Parts	Unit Bracket		1 EA/RRH
	Fasteners	M6 x L20 hexagonal bolt (Washer assembly)	4 EA/RRH
		M8 x L30 hexagonal bolt (Washer assembly)	1 EA/RRH
Recommended Torque Value	M6 hexagonal bolt	43 lbf-in	
Working Tools	<ul style="list-style-type: none"> <li>• Torque Wrench (10 to 50 lbf-in)</li> <li>• Torque Wrench Spanner Head (apply hexagonal head: 10 mm)</li> <li>• Spanner (apply hexagonal head: 13 mm)</li> </ul>		

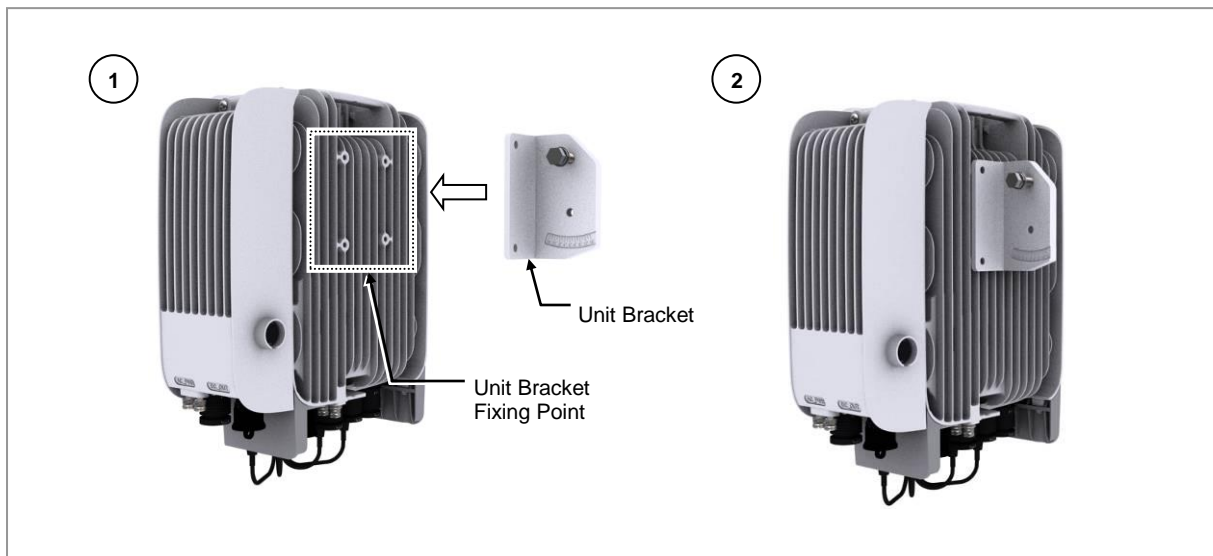
- 1 Inset the M8 hexagonal bolt to the unit bracket temporarily.

**Figure 22. Fixing Unit Bracket (1)**



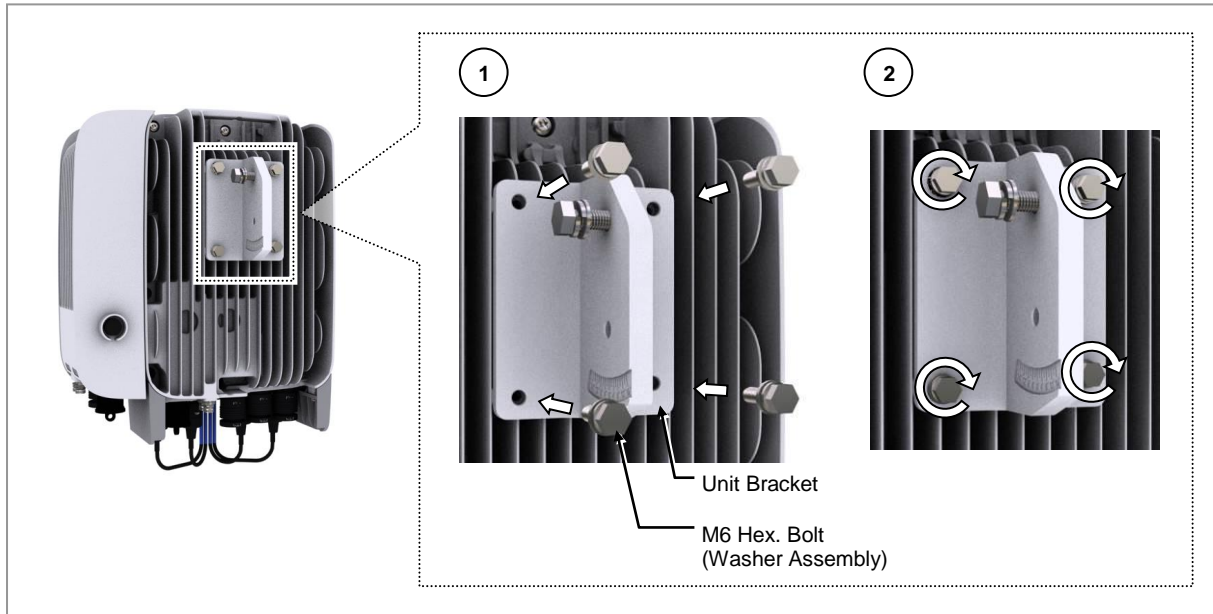
- 2 Check the position for mounting the unit bracket on the back of the RRH and place it in that position.

**Figure 23. Fixing Unit Bracket (2)**



- 3 Fix the unit bracket using the fasteners.

**Figure 24. Fixing Unit Bracket (3)**



**Fixing Pole Type\_1 Sector**

This section describes the procedures for fixing the system on the pole.



The standard of the pole on which the mounting bracket can be attached using steel bands is 50 A to 125 A. When installing on a pole of 125 A or more, the steel band should be replaced.

**Assembling Mounting Bracket**

To assemble the mounting bracket for 1-sector, do the following:

**Prerequisites**

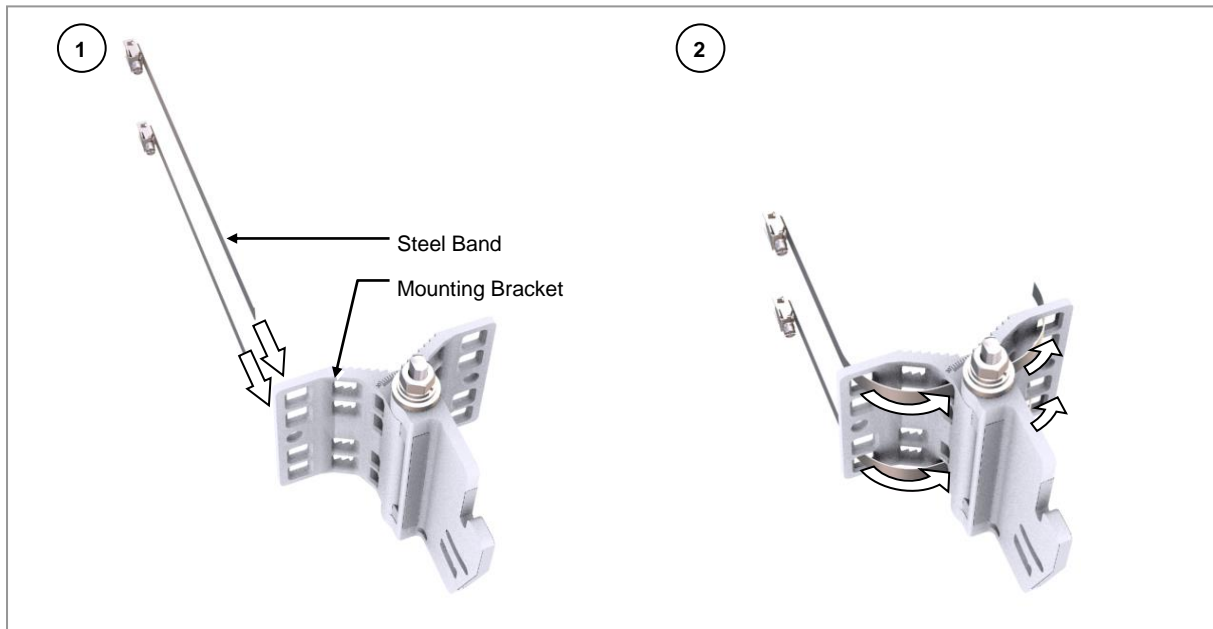
Before proceeding with assembling the mounting bracket for 1-sector, make sure that you have the items mentioned in the table below:

**Table 7. Parts and Tools for Fixing Mounting Bracket on the Pole**

Category	Description		
Parts	Mounting Bracket		1 EA
	Fasteners	Steel Band	2 EA
Recommended Torque Value	Steel Band Fixing Screw		110 lbf·in
Working Tools	<ul style="list-style-type: none"> <li>• Torque Driver (20 to 90 lbf·in)</li> <li>• Screw Driver Bit ('+', No. 3)</li> <li>• Antenna Alignment Tool</li> </ul>		

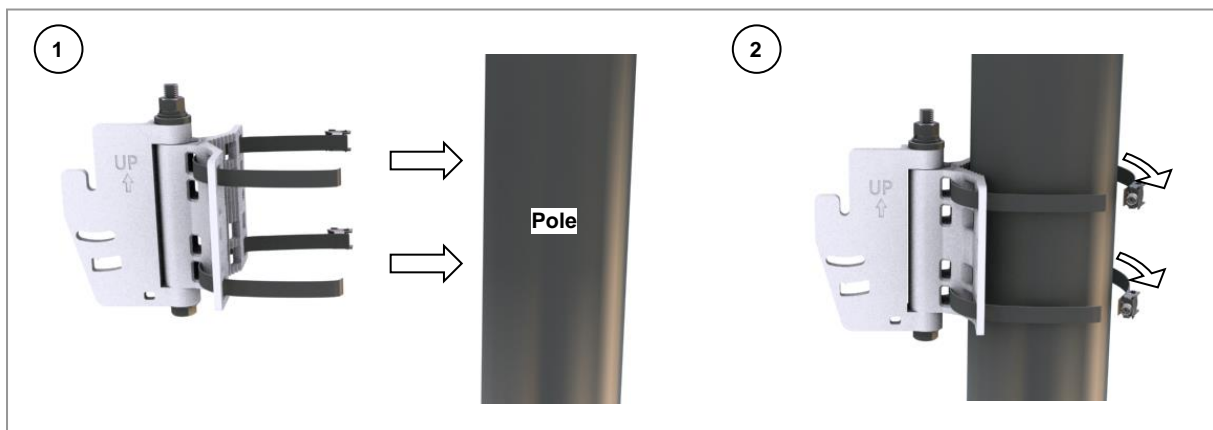
- 1 Pass the steel band through the fixing hole of the mounting bracket.

**Figure 25. Fixing Mounting Bracket on the Pole (1)**



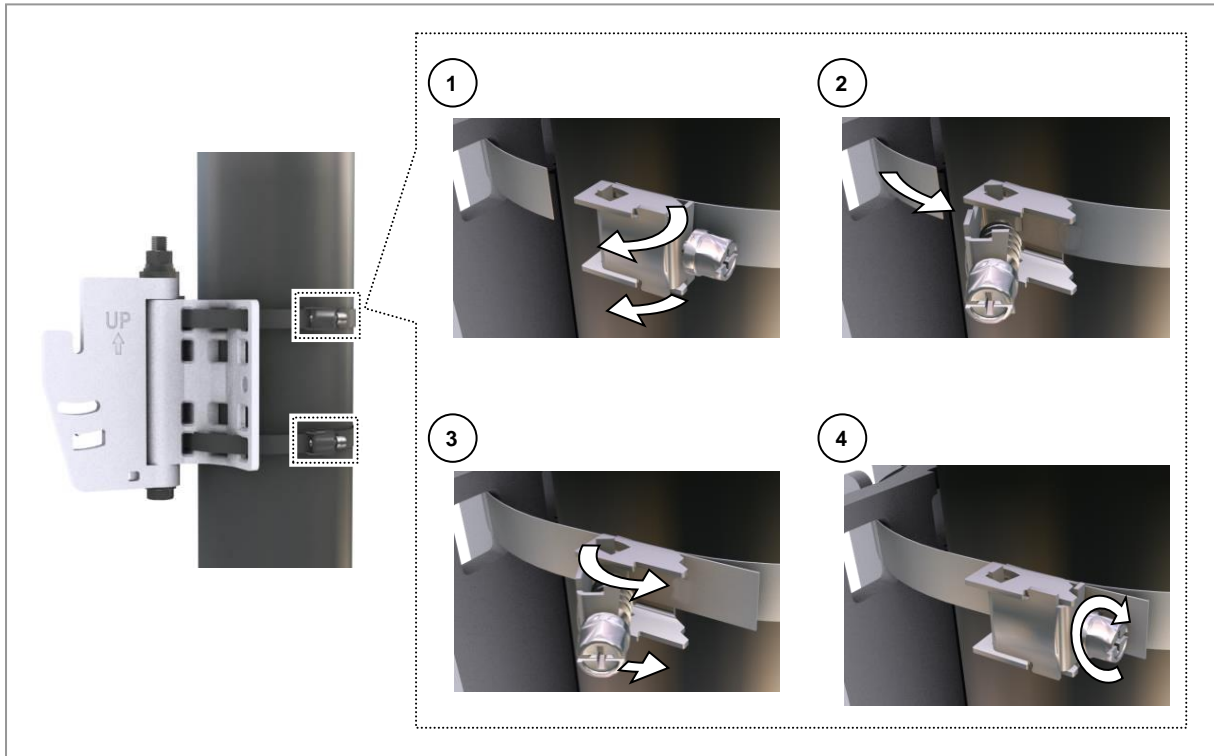
**2** Place the mounting bracket to the pole.

**Figure 26. Fixing Mounting Bracket on the Pole (2)**



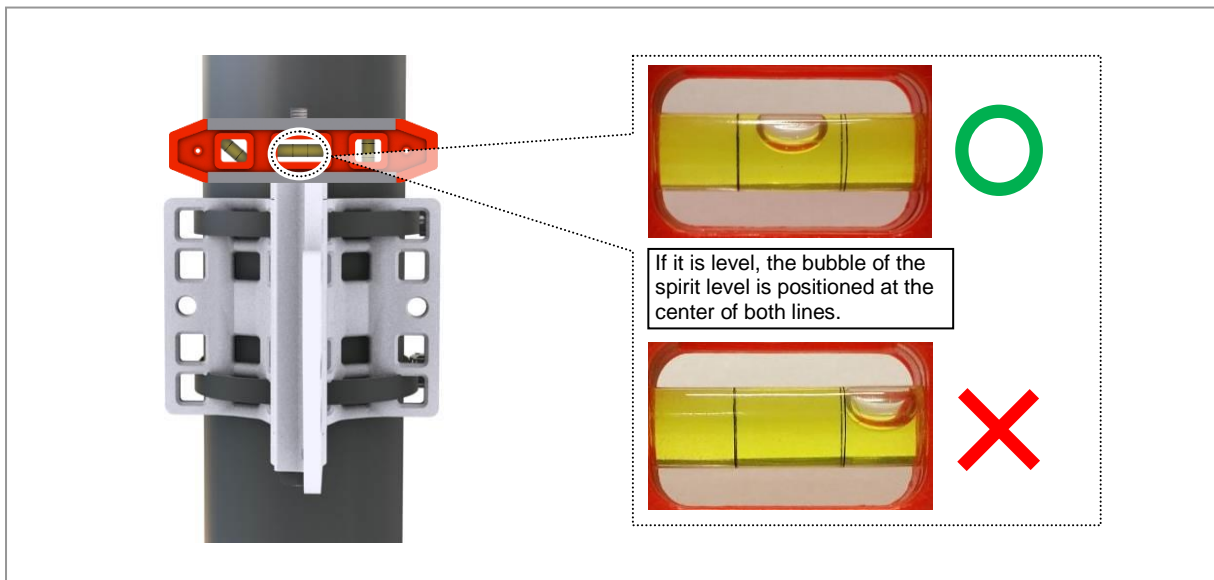
**3** Fix the mounting bracket to the pole using the steel band.

**Figure 27. Fixing Mounting Bracket on the Pole (3)**





**4** Check the level of mounting bracket on the pole and adjust the level.

**Figure 28. Fixing Mounting Bracket on the Pole (4)**



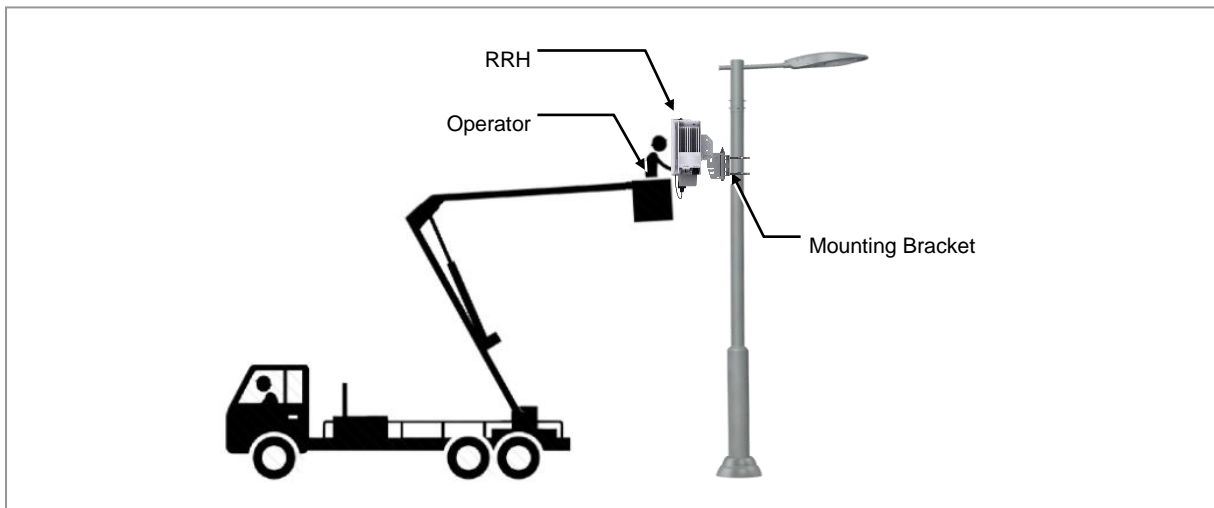
When fixing the mounting bracket on the pole, ensure to check the level of bracket. After finishing the installation, adjust the level minutely.

-  When poor leveling happens, adjust the position of fasteners used to fix the mounting bracket.
-  After fixing the steel band, push the remainder of band inside the mounting bracket.

**Lifting RRH**

To lift the RRH, do the following:  
Lift the RRH with a cherry picker.

*Figure 29. Lifting RRH*



**Fixing RRH on the Pole**

To fix the RRH on the pole, do the following:

**Prerequisites**

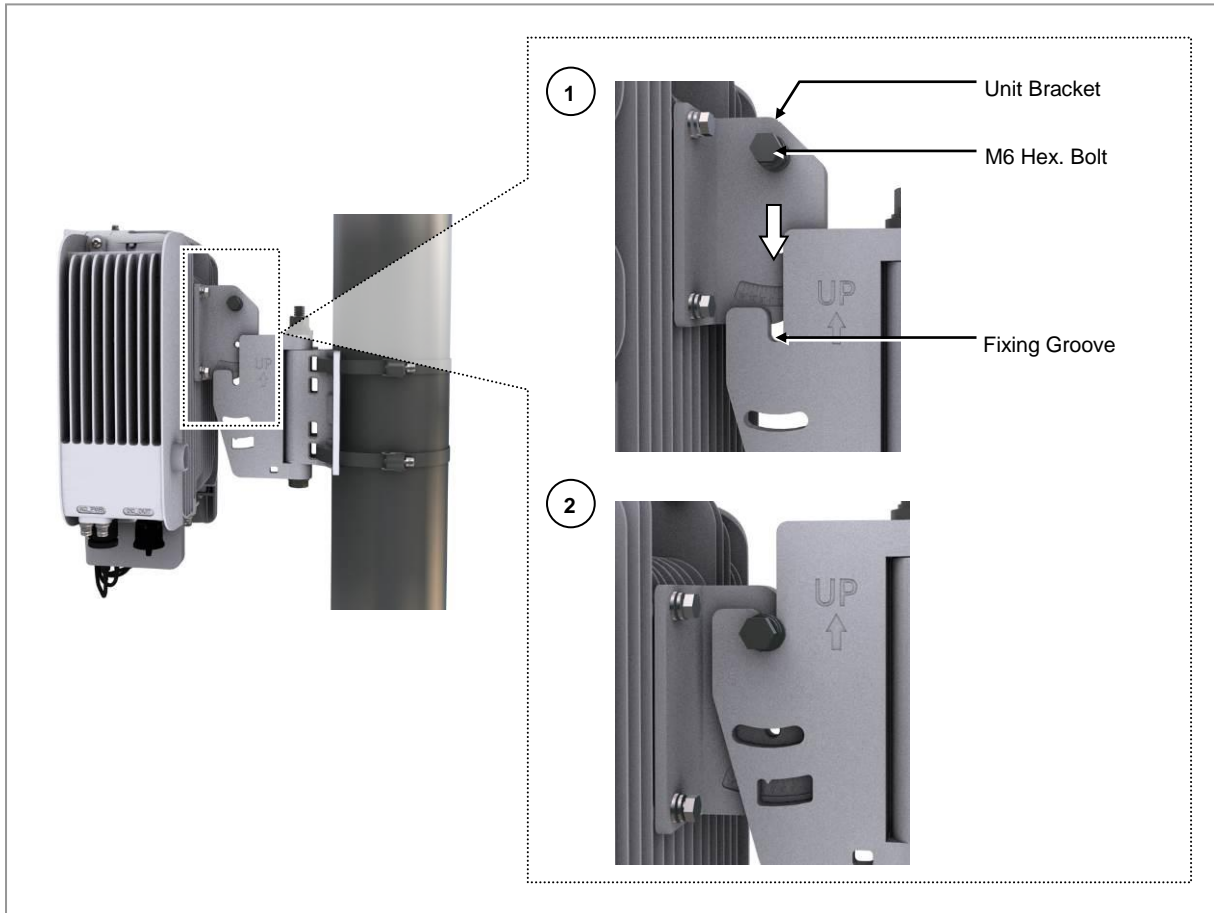
Before proceeding with fixing the RRH on the pole, make sure that you have the items mentioned in the table below.

*Table 8. Parts and Tools for Fixing RRH on the Pole*

Category	Description	
Fasteners	M8 x L30 hexagonal bolt (Washer assembly)	1 EA
Recommended Torque Value	M8 hexagonal. bolt	110 lbf-in
Working Tools	<ul style="list-style-type: none"> <li>• Torque Wrench (100 to 400 lbf-in)</li> <li>• Torque Wrench Spanner Head (apply hexagon head: 13 mm)</li> <li>• RF Alignment Tool</li> </ul>	

- 1** Place the unit bracket on the fixing groove of the mounting bracket.

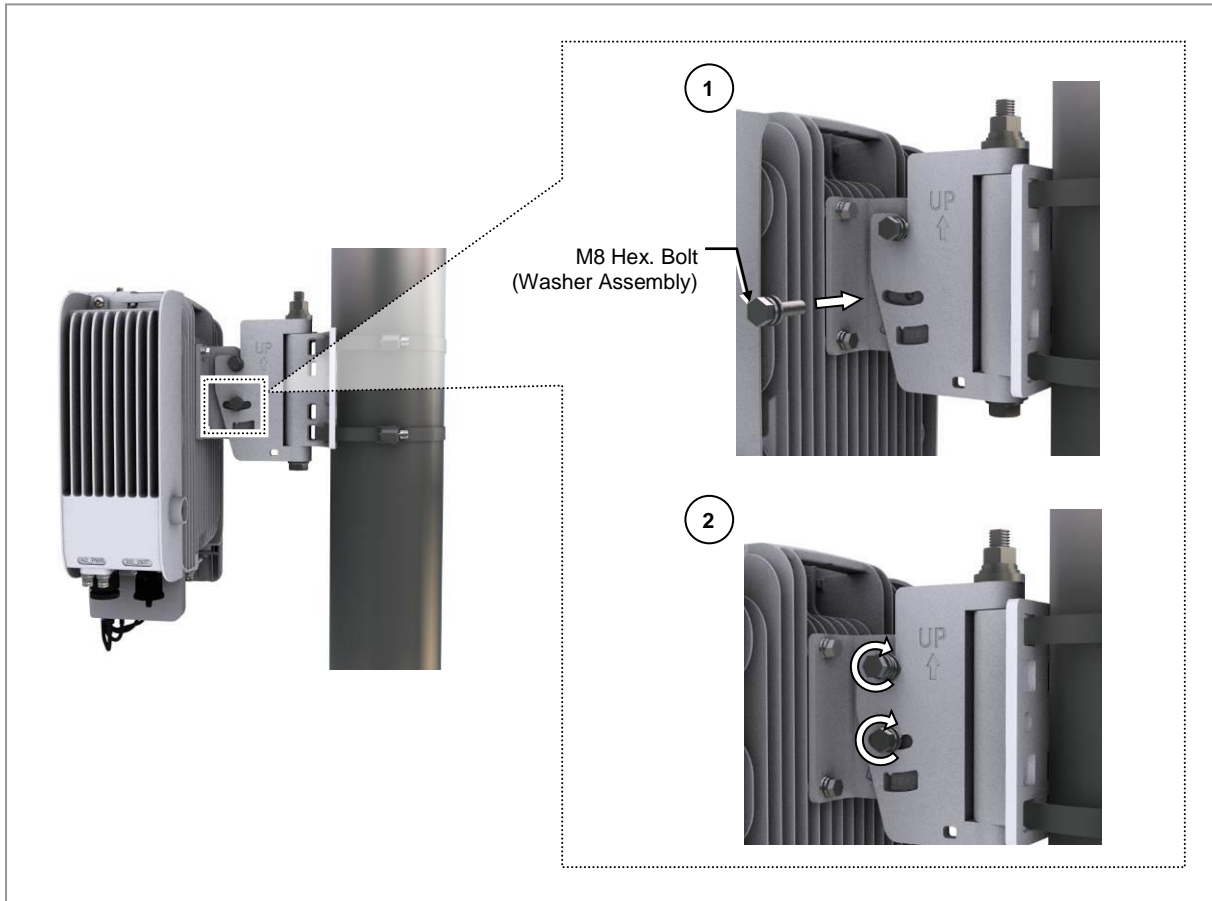
Figure 30. Fixing RRH on the Pole (1)



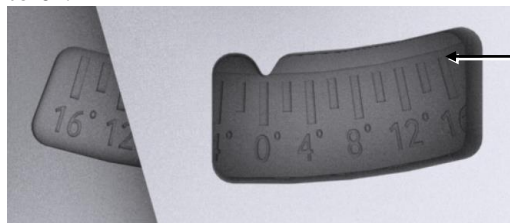
**2** Fix the RRH using the fasteners.



Figure 31. Fixing RRH on the Pole (2)



When installing the RRH, the tilting angle pointer of the unit bracket should point to 0°.



Tilting angle scale of the unit bracket

[Angle pointer position for unit bracket with 0° tilt when installing the RRH]

**3** Check the tilt and the azimuth using the RF alignment tool, and adjust when there is an issue.



For detailed instructions of how to use the RF alignment tool, refer to the user manual per manufacturer.

**Fixing Wall Type\_1 Sector**

This section describes the procedures for fixing the system on the wall.

**Fixing Mounting Bracket**

To fix the mounting bracket on the wall, do the following:

**Prerequisites**

Before proceeding with fixing the mounting bracket for 1-sector on the wall, make sure that you have the items mentioned in the table below.

**Table 9. Tools for Marking**

Category	Description
Working Tools	<ul style="list-style-type: none"> <li>• Tape Measure</li> <li>• Permanent Maker</li> <li>• Level</li> </ul>



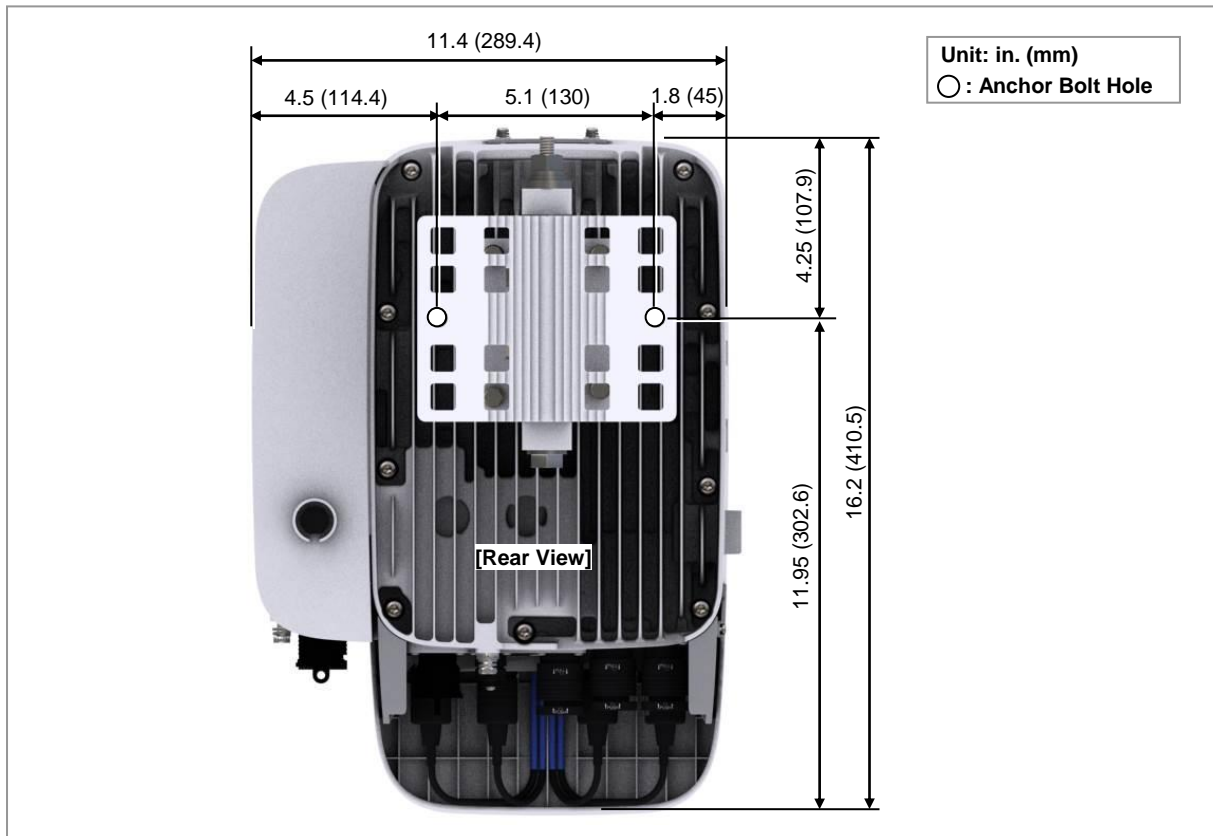
To mount the system on a wall, perform the leveling test by referring to the System Leveling to check the positions that are marked to be horizontal or vertical before the drilling process. If the result shows that they are not horizontal or vertical, modify the marking positions.



When the position where the system will be placed is determined, place the system on that position and then mark the positions where anchor bolts will be fixed. This will reduce marking error range.

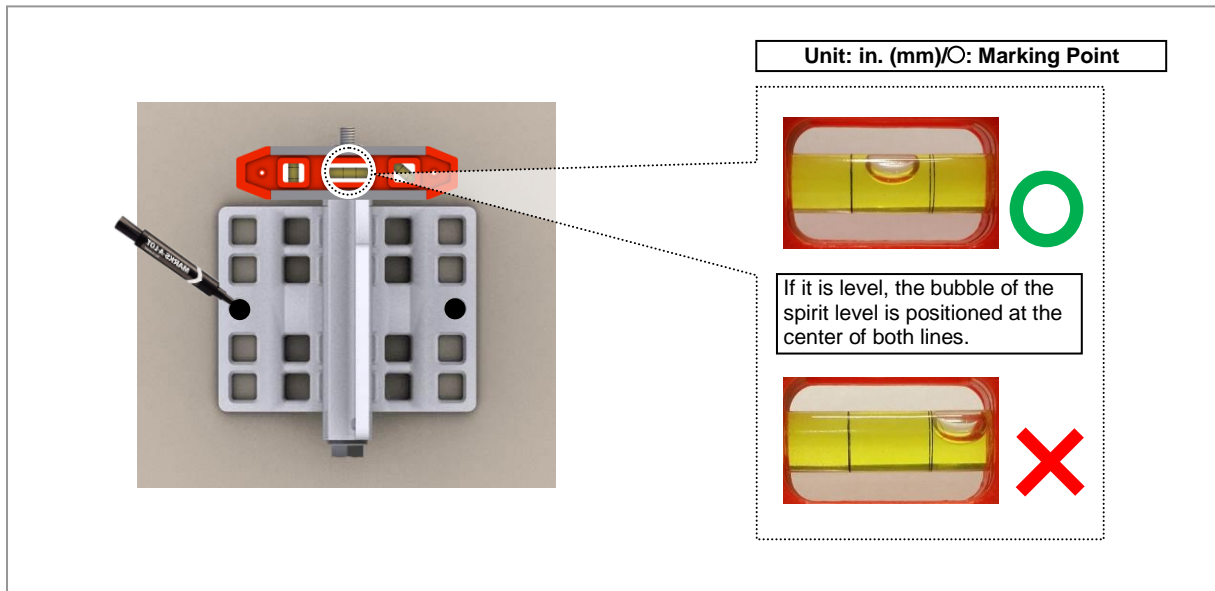
- 1 Check the distance between the location for fixing the RRH and the anchor bolt hole.

Figure 32. RRH Marking Dimensions



- 2 Place a mounting bracket on the fixing location, and then check the level status using a level, and adjust the level of bracket assembly.
- 3 If the level status is normal, mark the anchor bolt holes on a wall.

Figure 33. Marking



**Prerequisites**

Before proceeding with the drilling process, make sure that you have items mentioned in the following table

Table 10. Parts and Tools for Drilling

Category	Description
Working Tools	<ul style="list-style-type: none"> <li>• Hammer Drill</li> <li>• Concrete Drill Bit [0.6 in. (14 mm)]</li> <li>• Vacuum Cleaner</li> </ul>

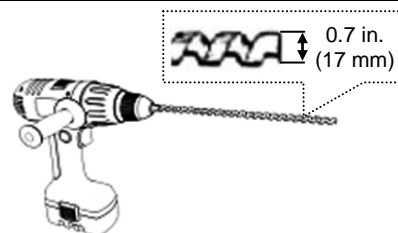
Table 11. Anchor Bolt Drill Bits and Hole Depth

Category	Anchor Bolt	Drill Bits	Hole Depth
RRH (Wall Type)	M10	0.6 in. (14 mm)	1.7 in. (44 mm)

[Anchor Hole Cross Section]

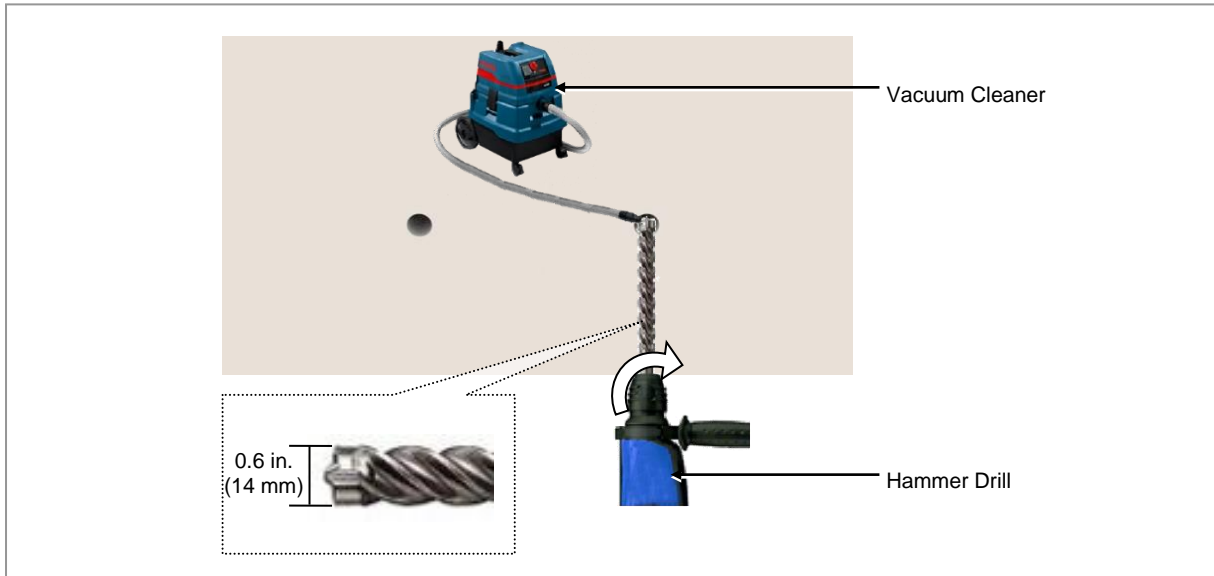


\* Remove the debris from the drilled hole.



Drill the anchor holes at the marked points. Remove dust from the holes using a vacuum cleaner.

Figure 34. Drilling



**Fixing Mounting Bracket on the Wall**

To fix the mounting bracket on the wall, do the following:

**Prerequisites**

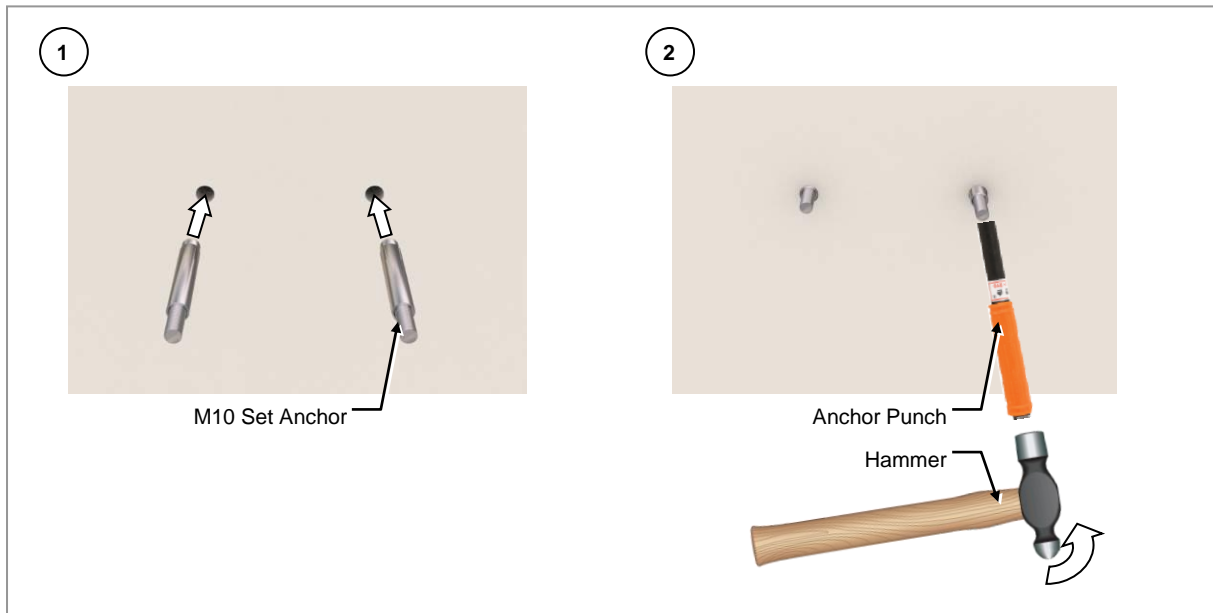
Before proceeding with fixing the mounting bracket for 1-sector on the wall, make sure that you have the items mentioned in the table below:

Table 12. Parts and Tools for Fixing Mounting Bracket on the Wall

Category	Description	
Parts	Mounting Bracket	1 EA
	Fasteners	M10 Set Anchor Assembly • M10 Set Anchor 1 EA/set • M10 Plain Washer 1 EA/set • M10 Spring Washer 1 EA/set • M10 Hexagonal. Nut 1 EA/set
Recommended Torque Value	M10 Hexagonal Nut	217 lbf-in
Working Tools	• Torque Wrench (100 to 400 lbf-in) • Torque Wrench Spanner head (apply Hex. head: 17 mm) • Spanner (17 mm) • Hammer • Anchor Punch (for M10 set anchor bolt)	

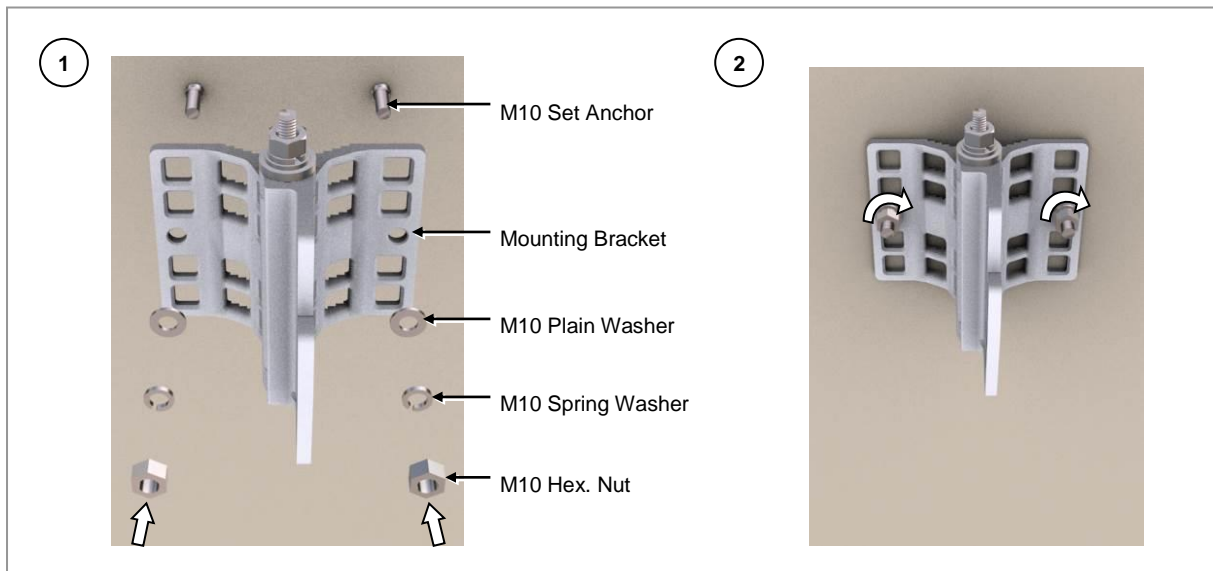
- 1 Fix the anchor to the drilled hole.

**Figure 35. Fixing Mounting Bracket on the Wall (1)**



2 Place the mounting bracket on the wall and fix it using the fasteners.

**Figure 36. Fixing Mounting Bracket on the Wall (2)**



**Fixing RRH on the Wall**

To fix the RRH on the wall, do the following:

**Prerequisites**

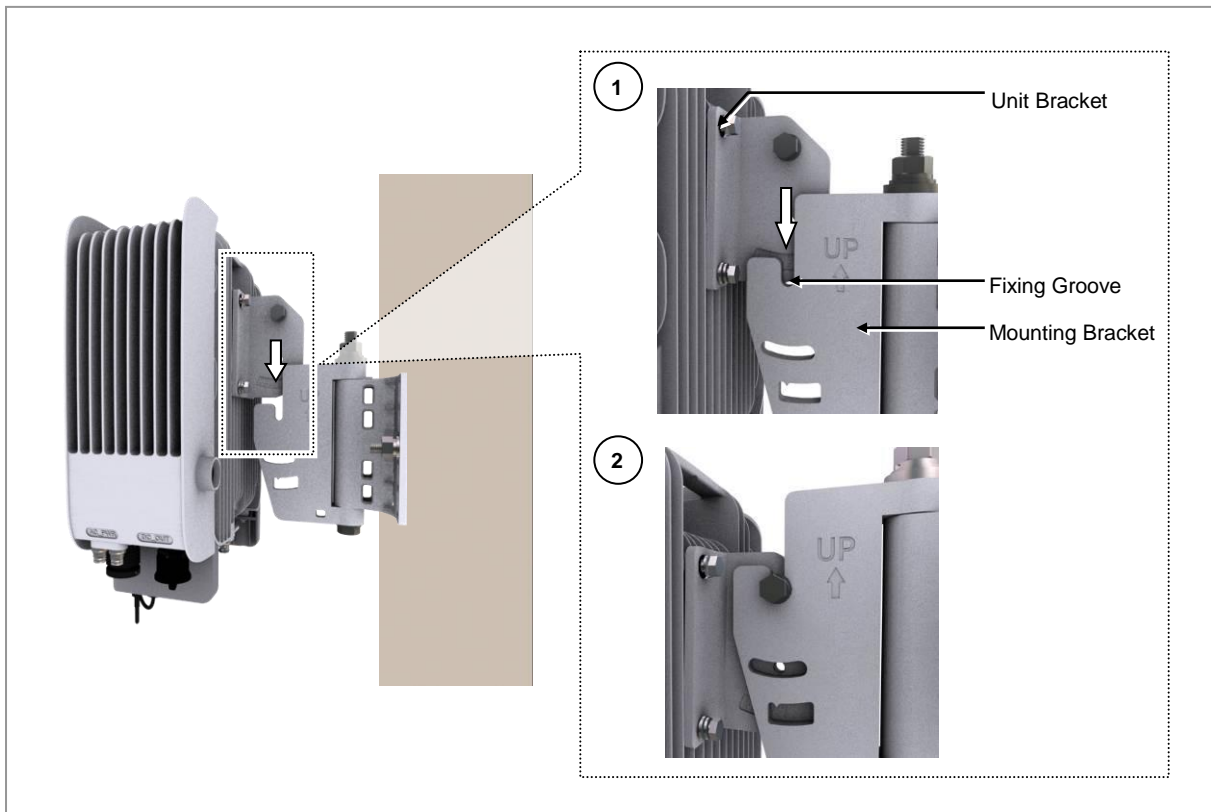
Before proceeding with fixing the RRH on the wall, make sure that you have the items mentioned in the table below:

**Table 13. Parts and Tools for Fixing RRH on the Wall**

Category	Description	
Fasteners	M8 x L30 hexagonal bolt (Washer assembly)	1 EA
Recommended Torque Value	M8 hexagonal. bolt	110 lbf-in
Working Tools	<ul style="list-style-type: none"> <li>• Torque Wrench (100 to 400 lbf-in)</li> <li>• Torque Wrench Spanner Head (apply Hex. head: 13 mm)</li> <li>• RF Alignment Tool</li> </ul>	

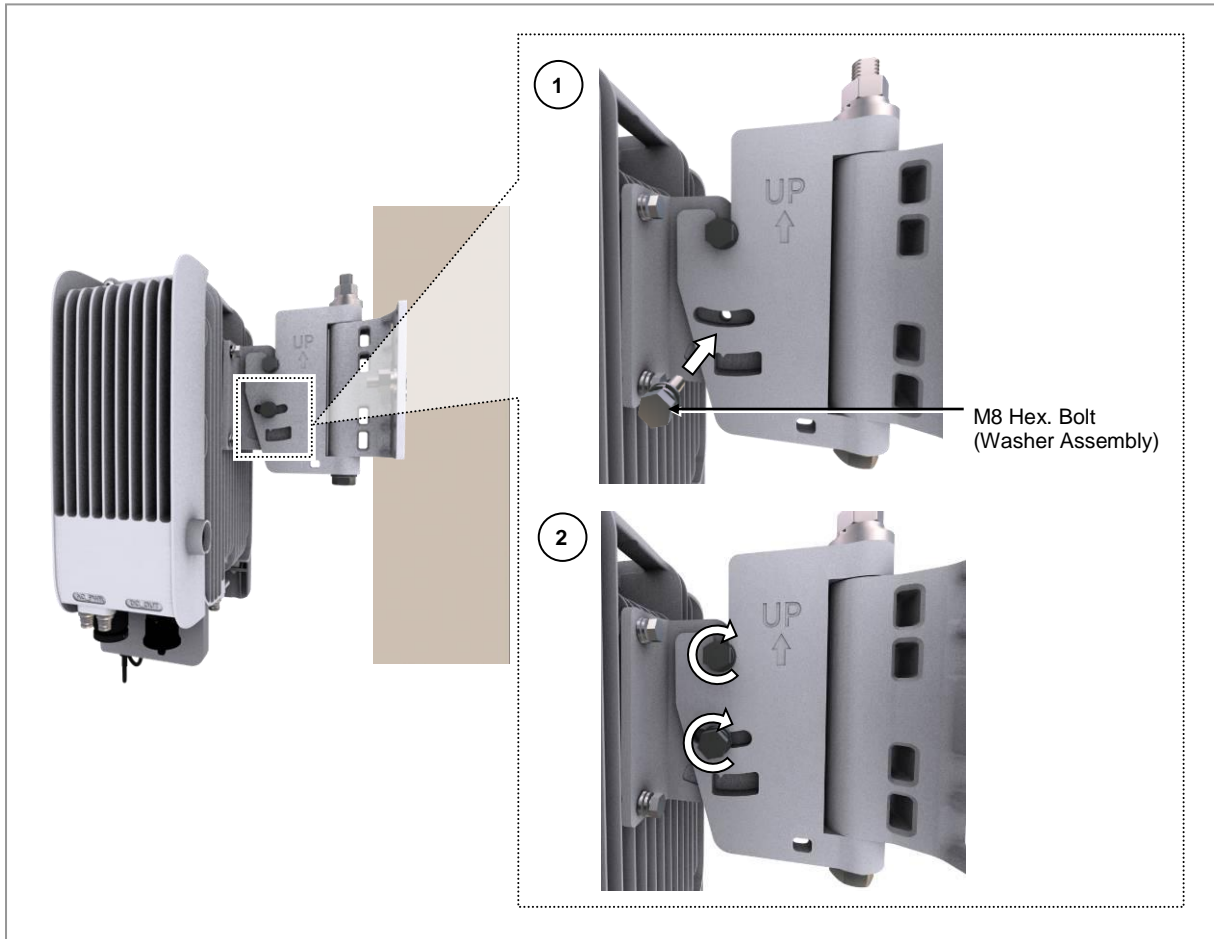
- 1 Place the unit bracket on the fixing groove of the mounting bracket.

**Figure 37. Fixing RRH on the Wall (1)**



- 2 Fix the RRH using the fasteners.

Figure 38. Fixing RRH on the Wall (2)



**3** Check the tilt and the azimuth using the RF alignment tool, and adjust when there is an issue.



For detailed instructions on how to use the RF alignment tool, refer to the user manual per manufacturer.

**Tilting**



The instructions for tilting the RRH apply to all installation types.



The adjustable tilting range is as follows:

- Down tilting: 0° to 16°
- Up tilting: 0° to 16°

To adjust the RRH tilting, do the following:

**Prerequisites**

Before proceeding with adjusting the RRH tilting, make sure that you have the items mentioned in the table below:

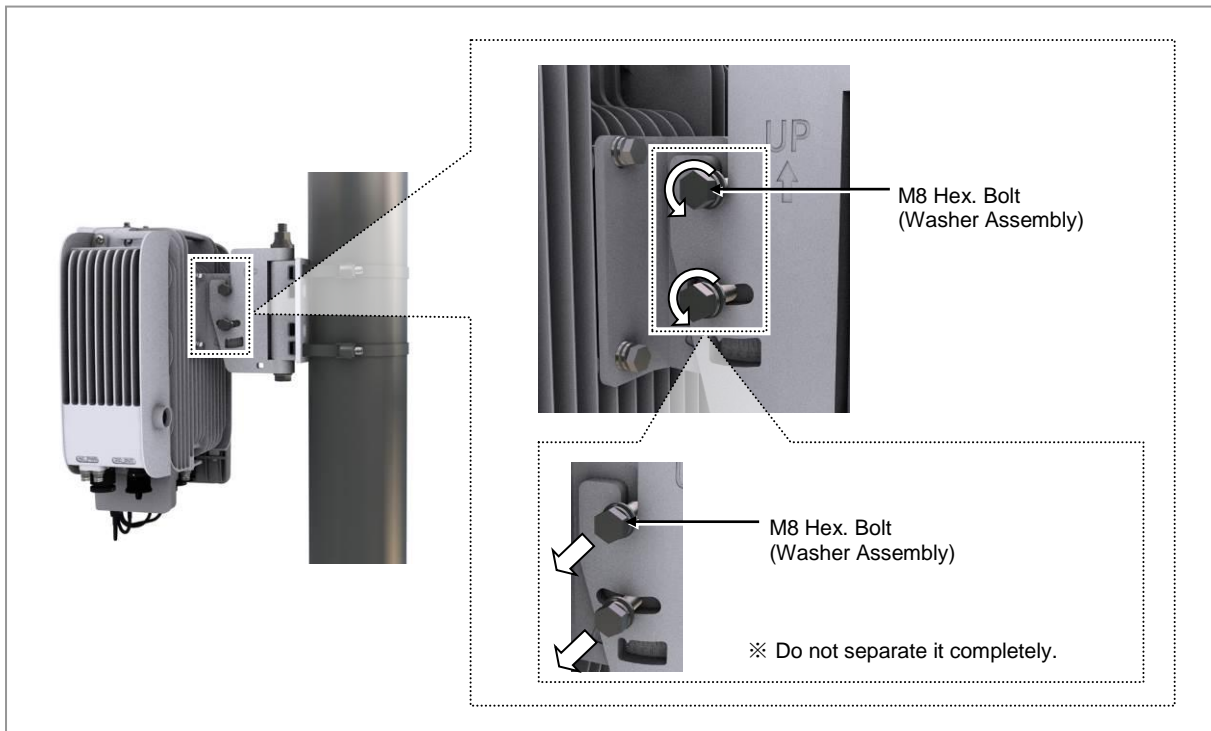


**Table 14. Tools for Tilting RRH**

Category	Description	
Recommended Torque Value	M8 hexagonal bolt	110 lbf·in
Working Tools	<ul style="list-style-type: none"> <li>• Torque Wrench (100 to 400 lbf·in)</li> <li>• Torque Wrench Spanner Head (apply hexagonal. head: 13 mm)</li> <li>• Spanner (13 mm)</li> <li>• RF Alignment Tool</li> </ul>	

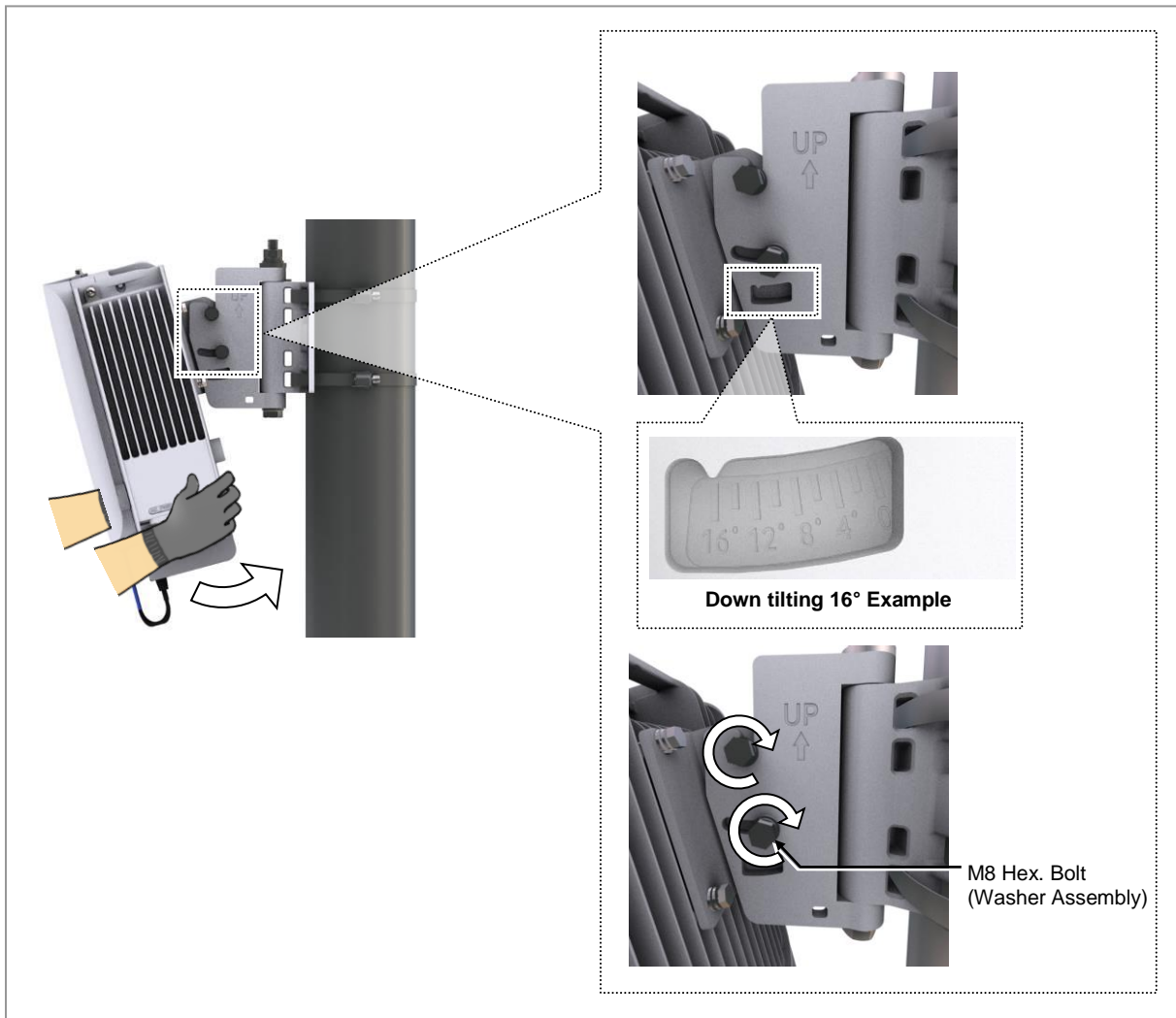
- 1 Loosen the RRH by turning M8 hexagonal bolt of mounting bracket two or three times counterclockwise. Do not separate it completely.

**Figure 39. RRH Tilting Adjustment (1)**



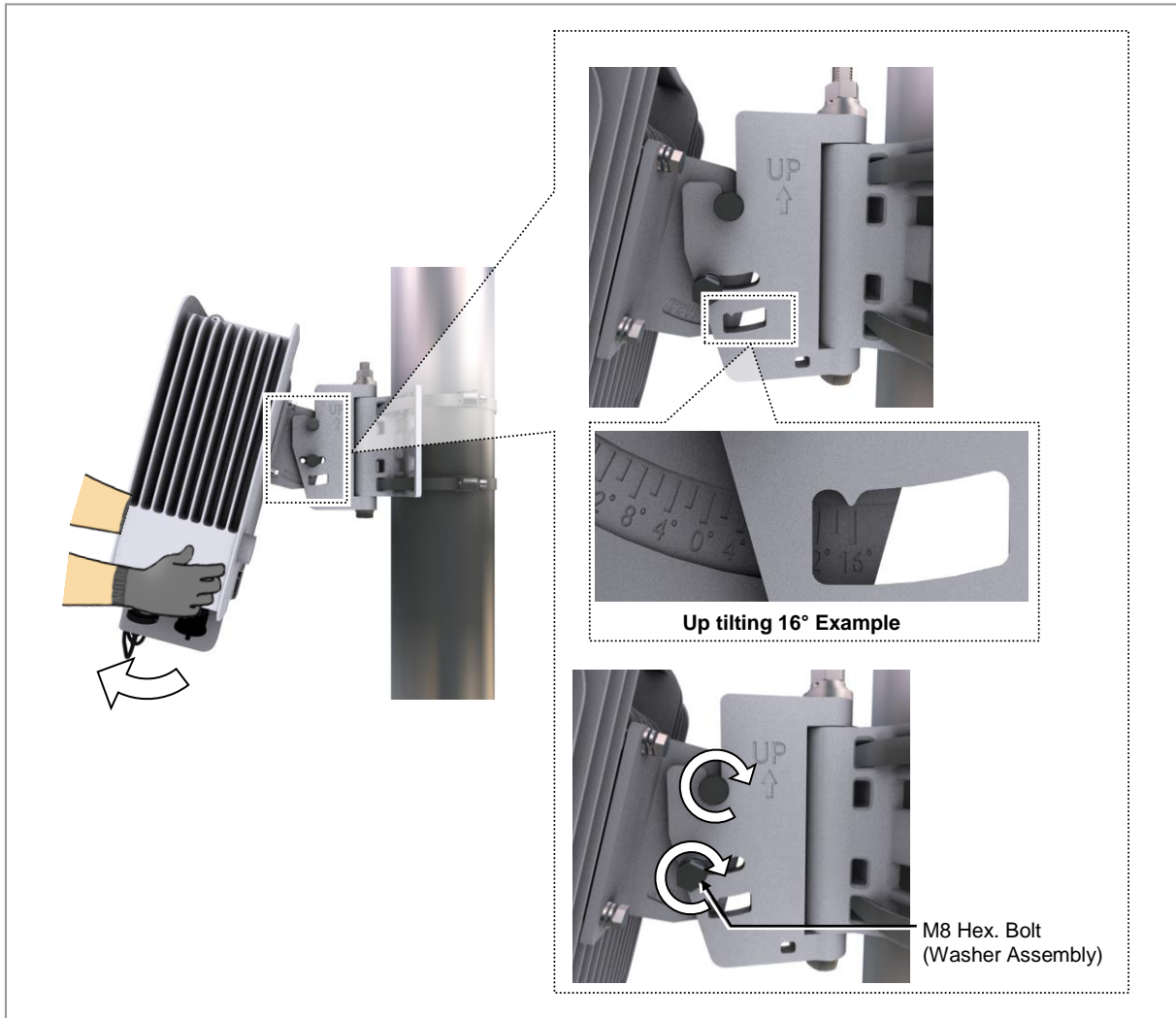
- 2 Push the RRH down to adjust the tilting angle and fix the RRH using the working tools.

Figure 40. RRH Tilting Adjustment (2)



**3** When executing up tilting, use the same method with down tilting.

Figure 41. RRH Tilting Adjustment (3)



**4** Check the tilt and the azimuth using the RF alignment tool and adjust when there is an issue.



For detailed instructions on how to use the RF alignment tool, refer to the user manual per manufacturer.

**Swiveling**



The instructions for swiveling the RRH apply to all installation types.



The adjustable swivelling is as follows:

- Left Swivelling: 0° to 30°
- Right Swivelling: 0° to 30°

To adjust the RRH swivelling, do the following

**Prerequisites**

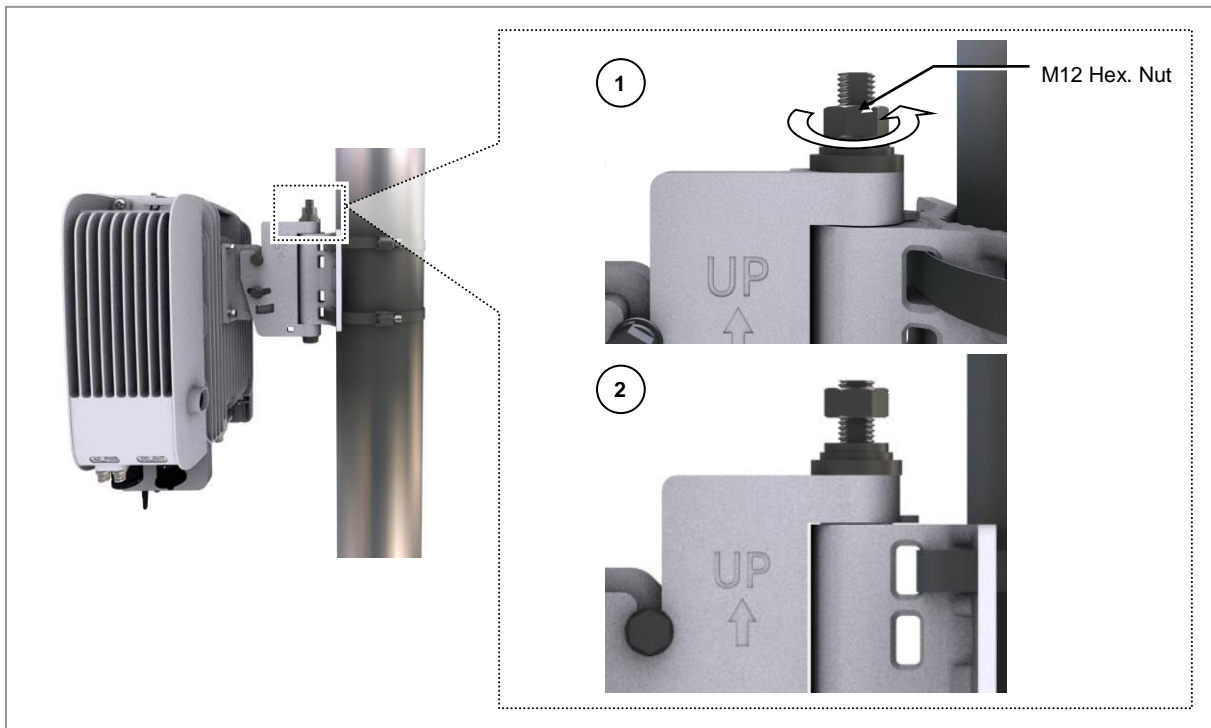
Before proceeding with swivelling the RRH, make sure that you have the items mentioned in the table below:

**Table 15. Tools for Swiveling RRH**

Category	Description	
Recommended Torque Value	M12 hexagonal nut	372 lbf-in
Working Tools	<ul style="list-style-type: none"> <li>• Torque Wrench (100 to 400 lbf-in)</li> <li>• Torque Wrench Spanner Head (apply Hex. head: 19 mm)</li> <li>• Spanner (19 mm)</li> <li>• RF Alignment Tool</li> </ul>	

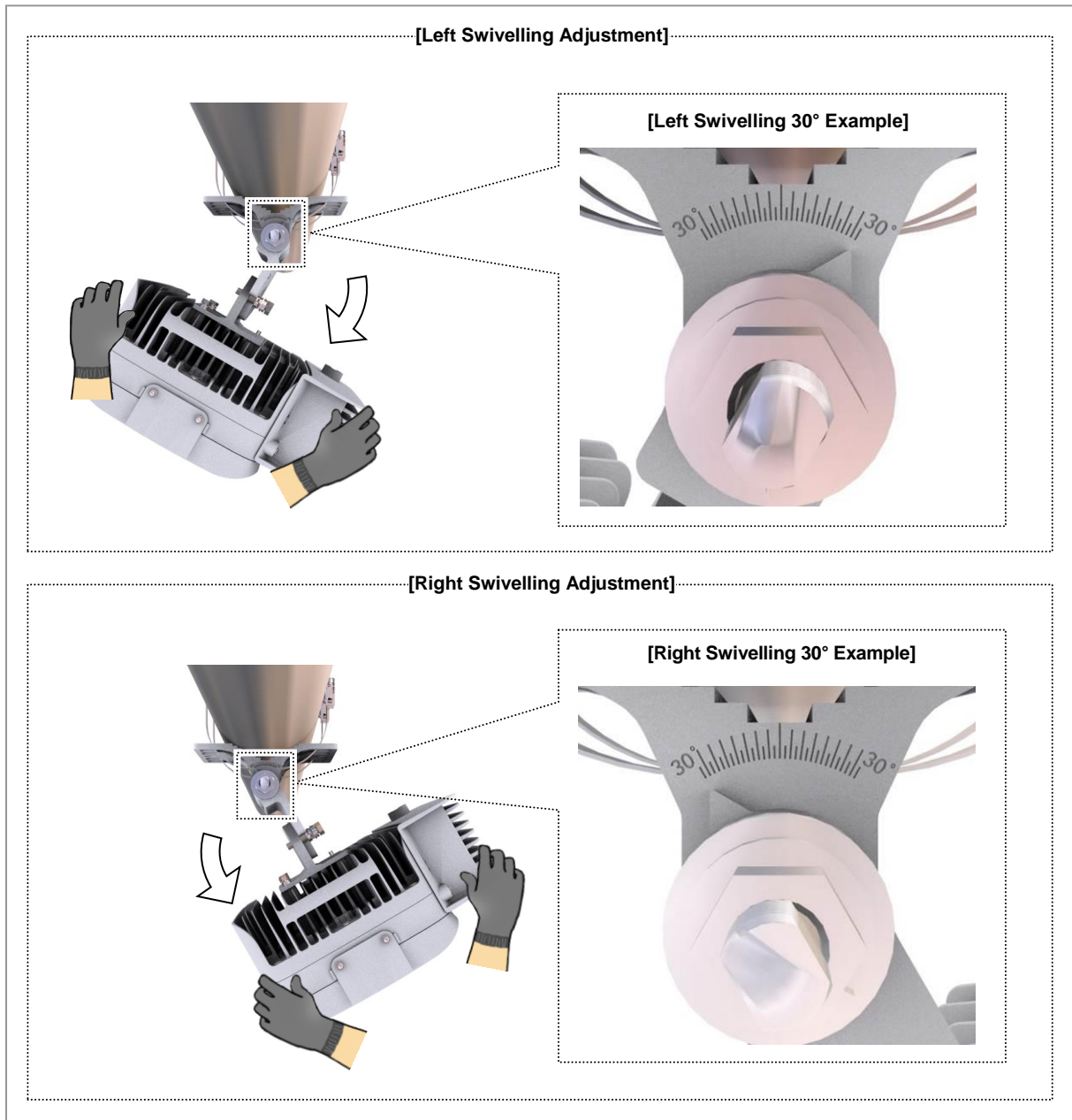
- 1 Loosen the RRH by turning M12 hexagonal nut of mounting bracket two or three times counter clockwise.  
Do not separate it completely.

**Figure 42. RRH Swivelling Adjustment (1)**



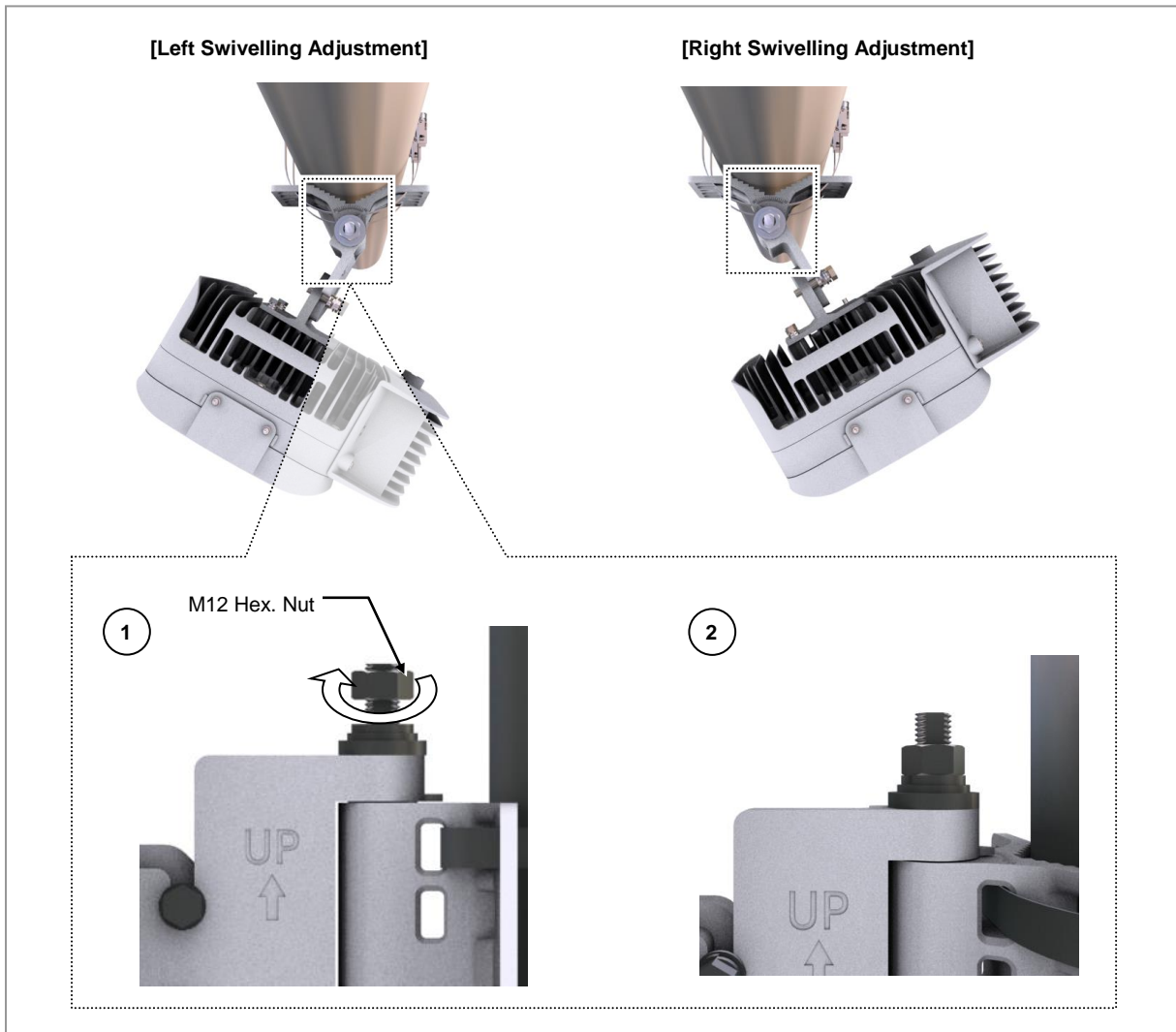
- 2 Pull the RRH left/right to adjust the swivelling angle.

Figure 43. RRH Swivelling Adjustment (2)



**3** Fix the RRH using the working tools.

Figure 44. RRH Swivelling Adjustment (3)



- 4 Check the tilt and the azimuth using the RF alignment tool, and adjust when there is an issue.



For detailed instructions of how to use the RF alignment tool, refer to the user manual per each manufacturer.

## Using Tilting Bracket

This section describes the procedure to fix the unit bracket using the tilting bracket.

### Fixing Unit Bracket



These instructions for mounting a unit bracket to the RRH apply to all installation types.

To fix the unit bracket, do the following:

**Prerequisites**

Before proceeding with fixing the unit bracket, make sure that you have the items mentioned in the table below:

**Table 16. Parts and Tools for Fixing Unit Bracket on RRH**

Category	Description	
Parts	Unit Bracket	
	Fasteners	M6 x L20 hexagonal bolt (Washer assembly)
		M8 x L30 hexagonal bolt (Washer assembly)
Recommended Torque Value	M6 hexagonal bolt	43 lbf-in
Working Tools	<ul style="list-style-type: none"> <li>• Torque Wrench (10 to 50 lbf-in)</li> <li>• Torque Wrench Spanner Head (apply Hex. head: 10 mm)</li> <li>• Spanner (apply Hex. head: 13 mm)</li> </ul>	



Refer to the 'tilting and swivelling bracket' assembly method to assemble the unit bracket.



**Assembling Mounting Bracket for 3 Sector Pole Type**

To assemble the mounting bracket for 3-sector, do the following:

**Prerequisites**

Before proceeding with assembling the mounting bracket for 3sector, make sure that you have the items mentioned in the table below:



Three RRHs can be installed when the pole diameter is more than 8 in. (200 A, 220 mm) to 12 in. (300 A, 320 mm).



The length of the steel band is 930 mm, 1160 mm, and 1330 mm, and it is used



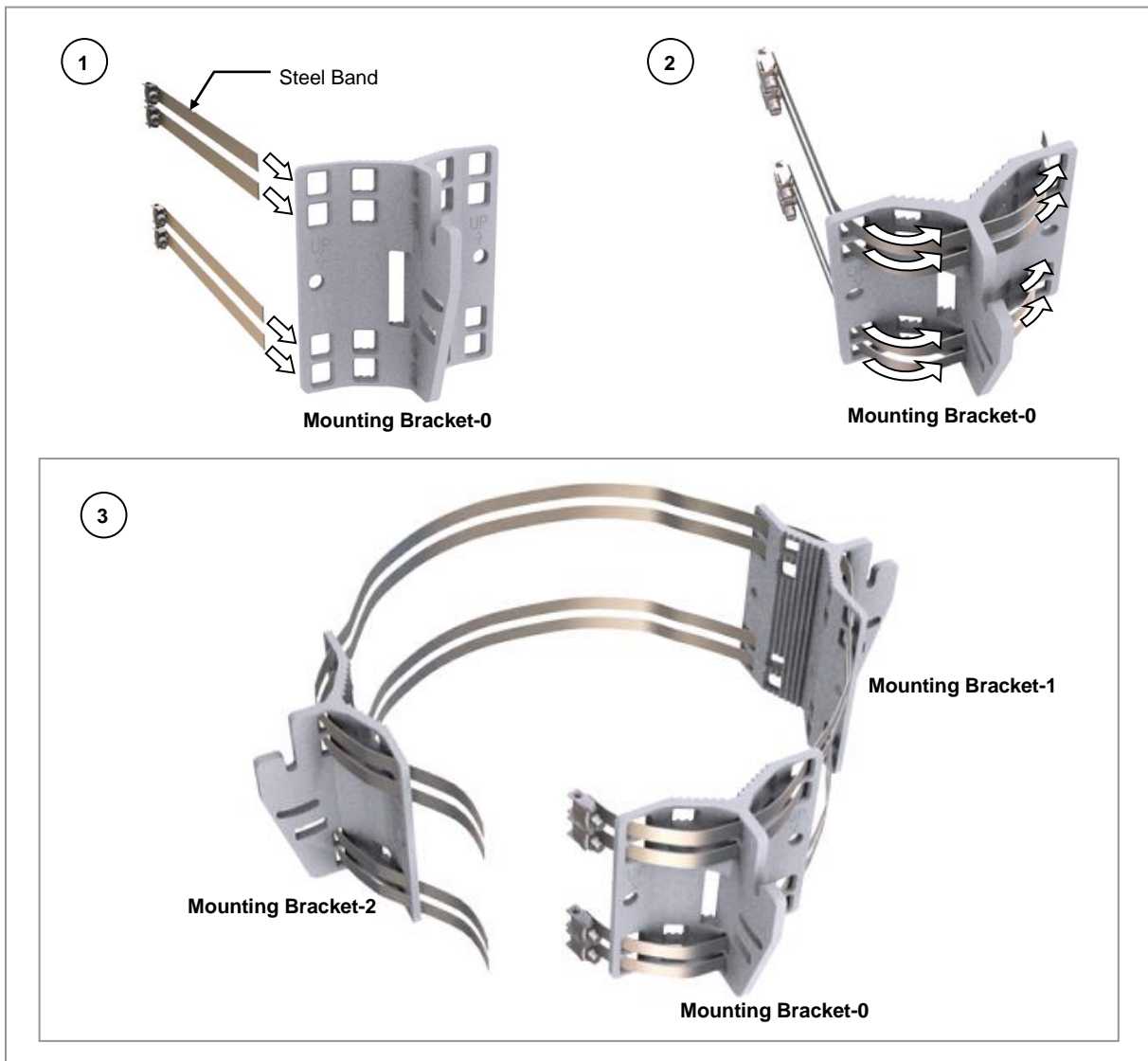
according to the pole diameter.

**Table 17. Parts and Tools for Fixing Mounting Bracket on the Pole**

Category	Description		
Parts	Mounting Bracket		3 EA
	Fasteners	Steel Band	4 EA
Recommended Torque Value	Steel Band Fixing Screw		110 lbf-in
Working Tools	<ul style="list-style-type: none"> <li>• Torque Driver (20 to 90 lbf-in)</li> <li>• Screw Driver Bit ('+', No. 3)</li> <li>• Antenna Alignment Tool</li> </ul>		

**1** Pass the steel band through the fixing hole of the mounting brackets.

**Figure 45. Fixing Mounting Bracket on the Pole (1)**





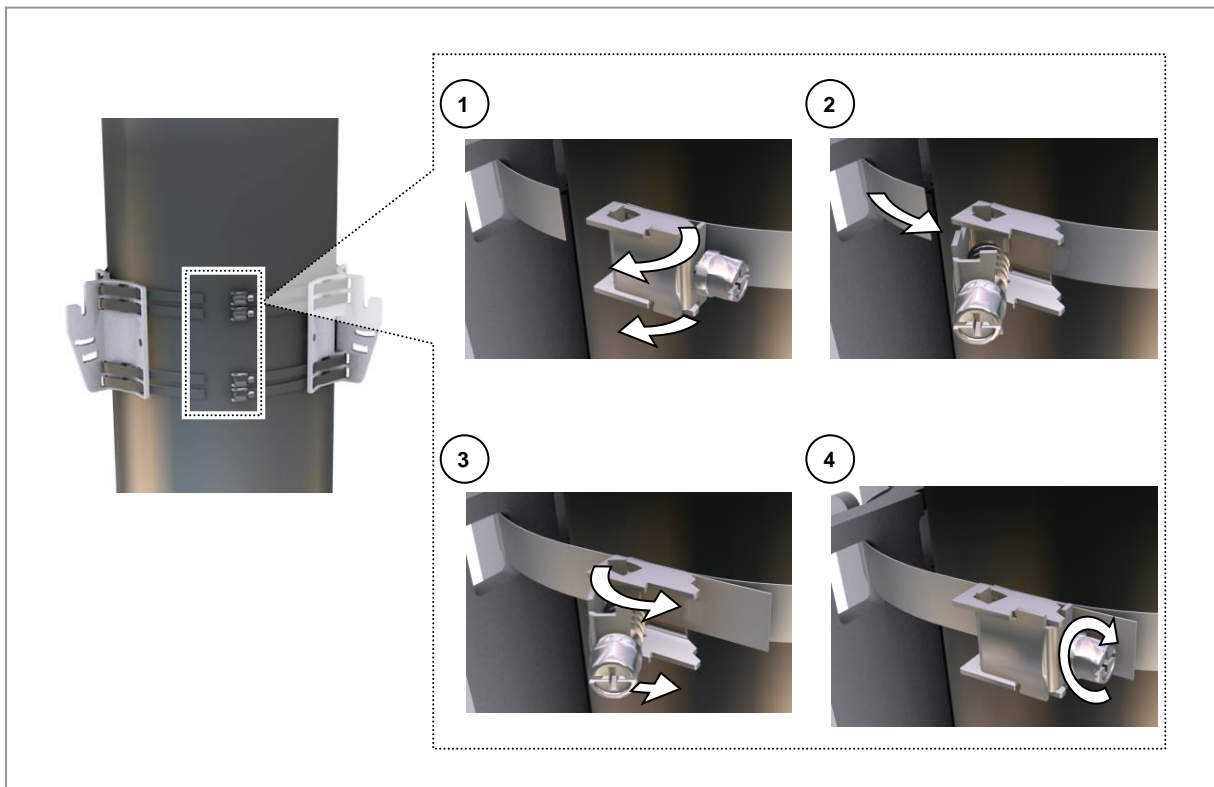
- 2 Place the mounting brackets to the pole.

*Figure 46. Fixing Mounting Bracket on the Pole (2)*



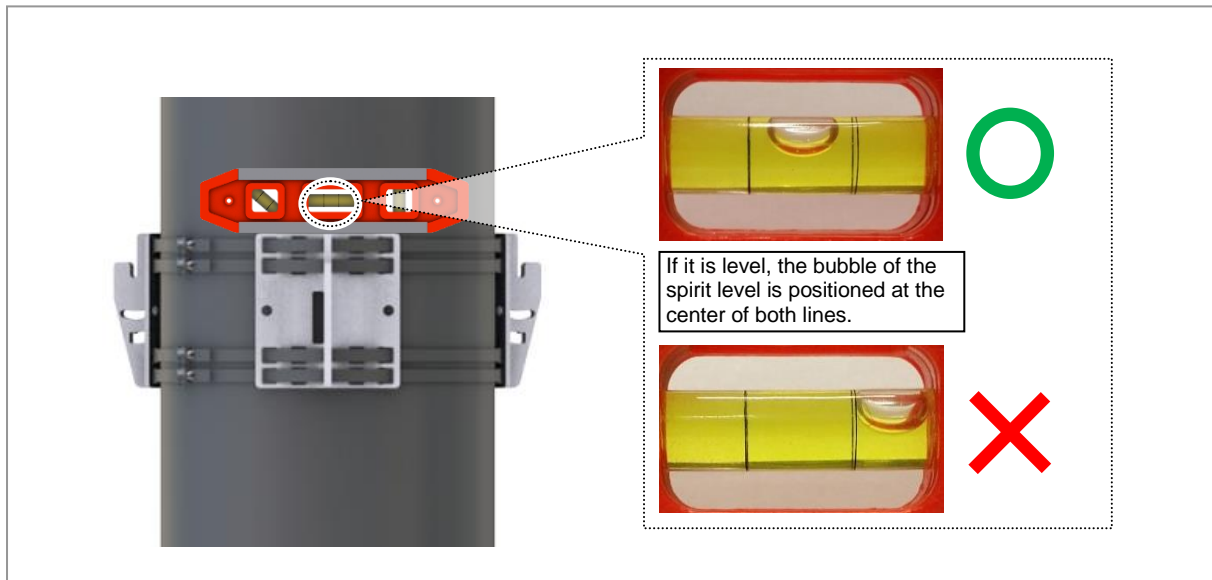
- 3 Fix the mounting brackets to the pole using the steel band.




*Figure 47. Fixing Mounting Bracket on the Pole (3)*



- 4 Check the level of each mounting brackets on the pole and adjust the level.

Figure 48. Fixing Mounting Bracket on the Pole (4)



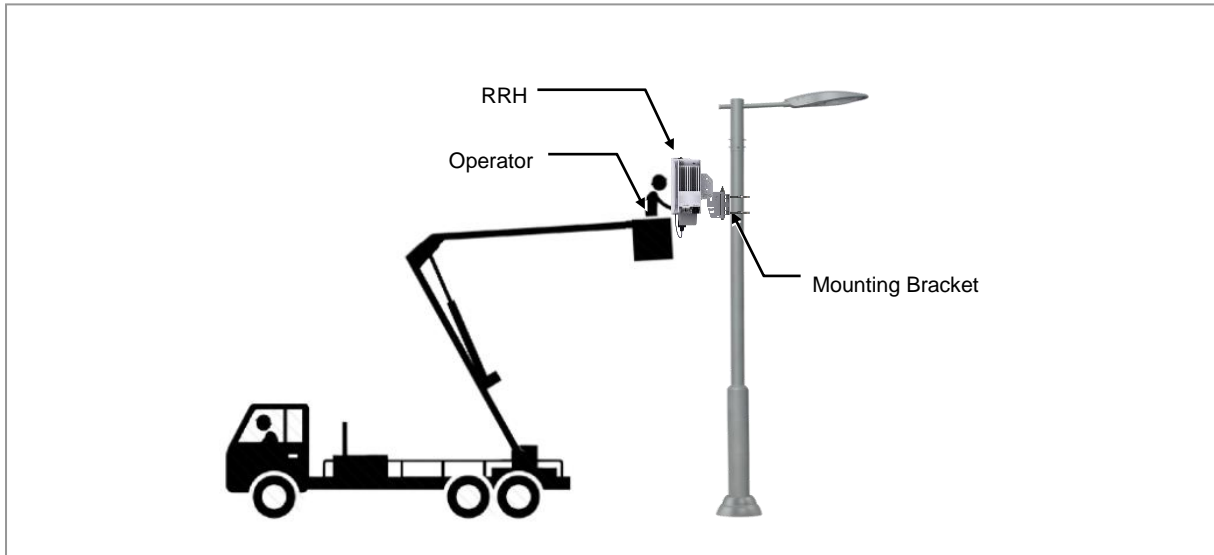
-  When fixing the mounting bracket on the pole, ensure to check the level of bracket. After finishing the installation, adjust the level minutely.
-  When poor leveling happens, adjust the position of fasteners to fix the mounting bracket.
-  After fixing the steel band, push the remainder of band inside the mounting bracket

### Lifting RRH

To lift the RRH, do the following:

Lift the RRH with a cherry picker.

**Figure 49. Lifting RRH**



**Fixing RRHs on the 3Sector Pole Type**

To fix the RRH on the pole, do the following:

**Prerequisites**

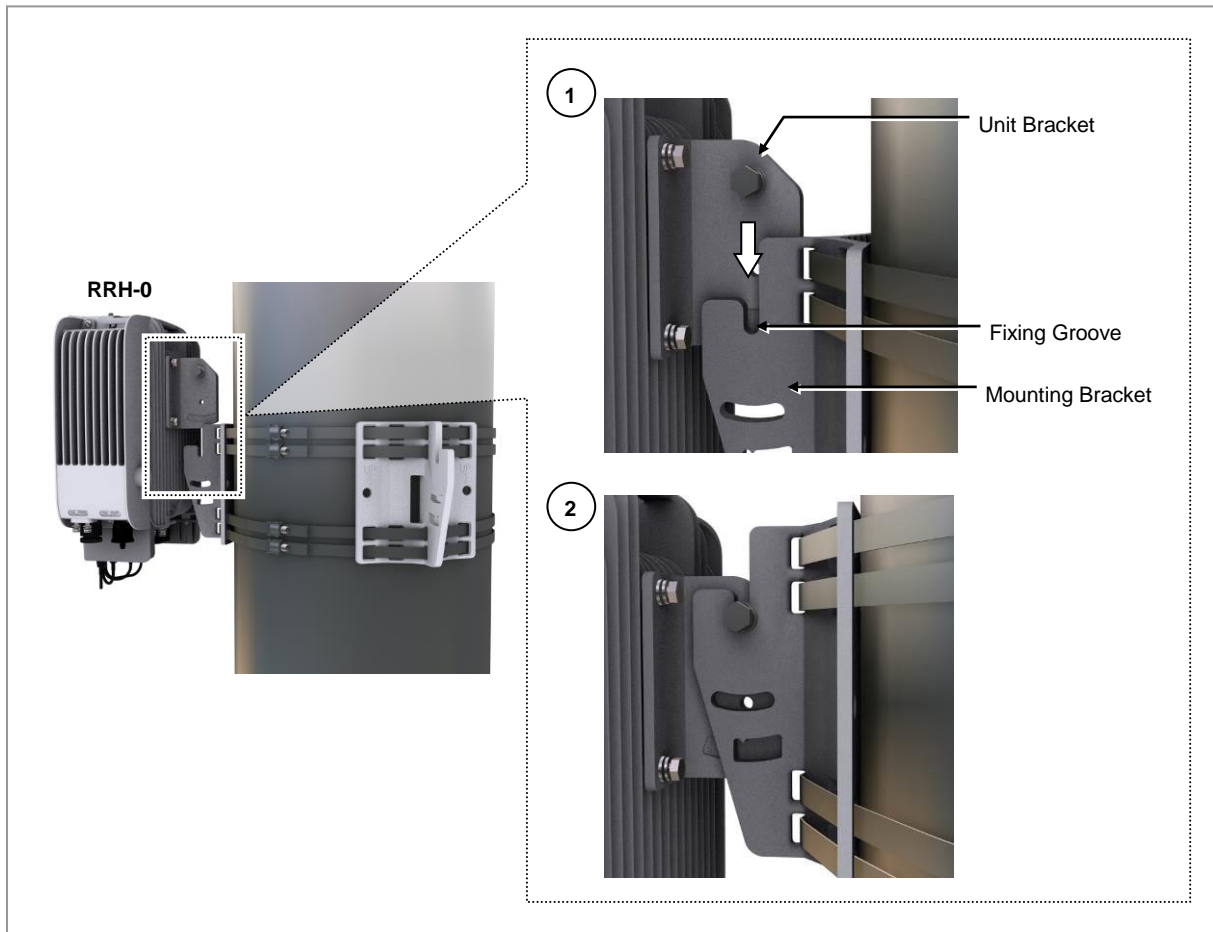
Before proceeding with fixing the RRH on the pole, make sure that you have items mentioned in the following table.

**Table 18. Parts and Tools for Fixing RRH on the 3Sector Pole Type**

Category	Description	
Fasteners	M8 × L30 hexagonal bolt (Washer assembly)	1 EA/RRH
Recommended Torque Value	M8 hexagonal bolt	110 lbf-in
Working Tools	<ul style="list-style-type: none"> <li>• Torque Wrench (100 to 400 lbf-in)</li> <li>• Torque Wrench Spanner Head (apply Hex. head: 13 mm)</li> <li>• Antenna Alignment Tool</li> </ul>	

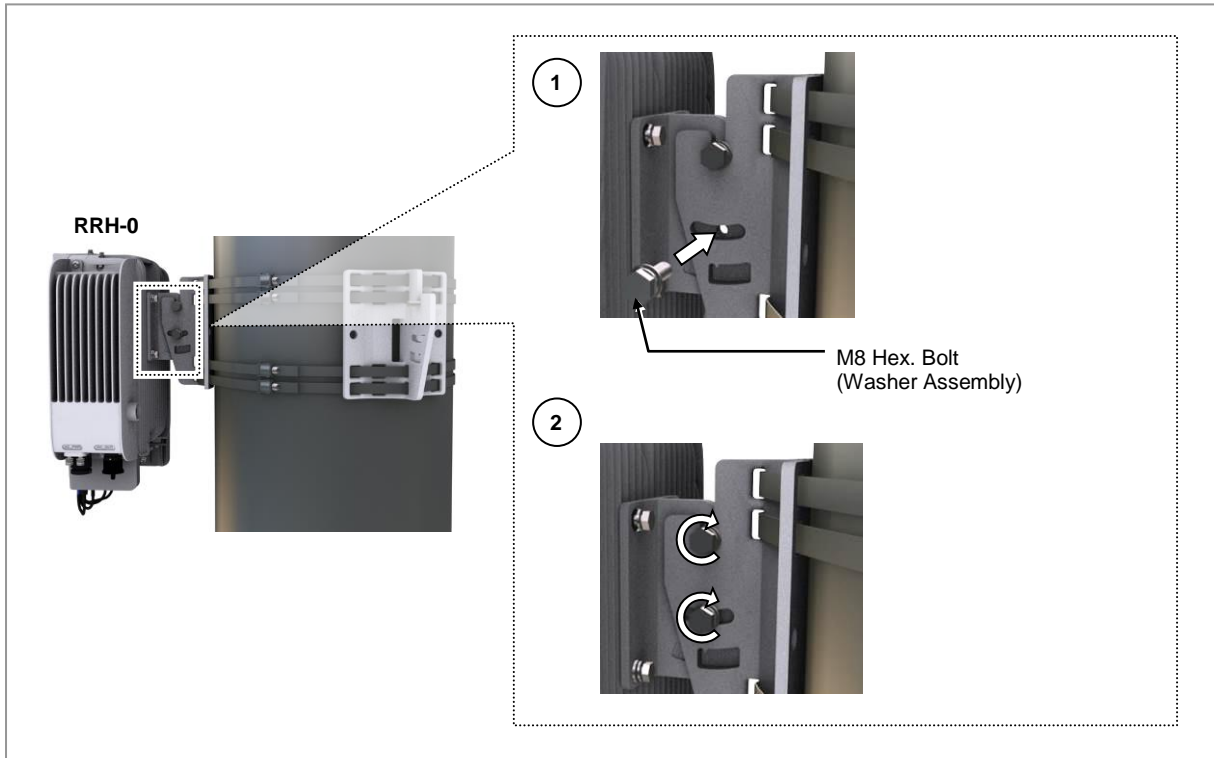
- 1** Place the unit bracket of RRH-0 on the fixing groove of the mounting bracket.

Figure 50. Fixing RRHs on the 3Sector Pole Type (1)

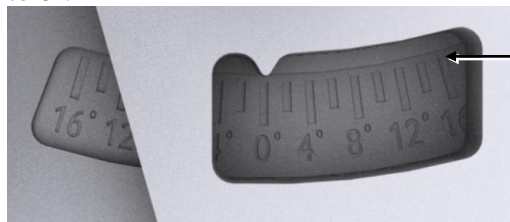


2 Fix the RRH-0 using the fasteners.

Figure 51. Fixing RRHs on the 3Sector Pole Type (2)



When installing the RRH, the tilting angle pointer of the unit bracket should point to 0°.



Tilting angle scale of the unit bracket

[Angle pointer position for unit bracket with 0° tilt when installing the RRH]

**3** Fix the RRH-1 and RRH-2 in the same way as the RRH-0.

Figure 52. Fixing RRHs on the 3Sector Pole Type (3)



- 4 Check the tilt and the azimuth using the RF alignment tool and adjust when there is an issue.



For detailed instructions of how to use the RF alignment tool, refer to the user manual per manufacturer.

## Without the Tilting Bracket

This section describes the procedures to fix the unit bracket and the mounting bracket.

### Fixing Unit Bracket

To fix the unit bracket without tilting bracket, do the following:

#### Prerequisites

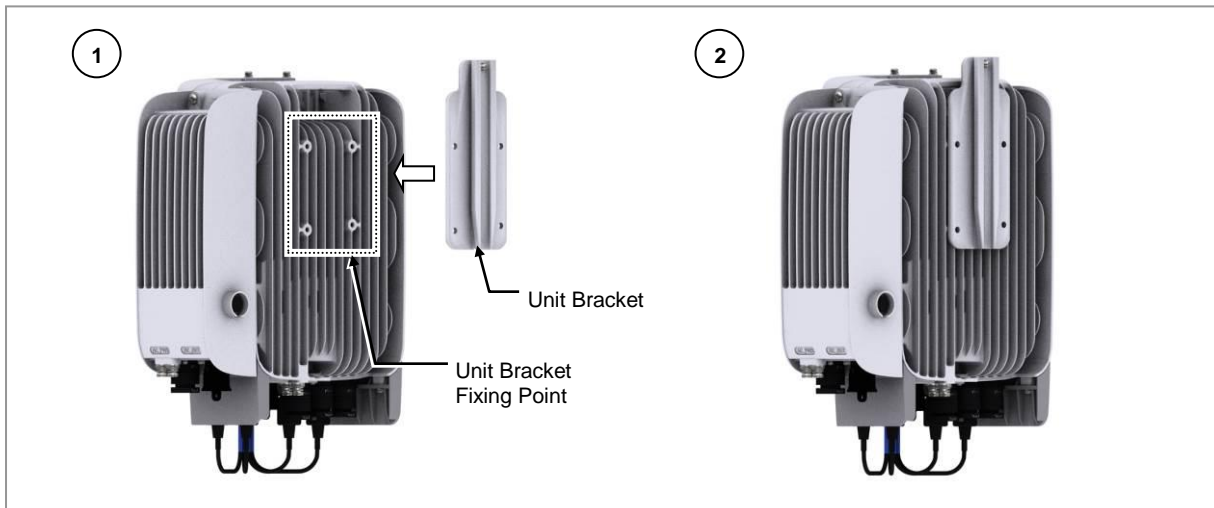
Before proceeding with fixing the unit bracket on the RRH, make sure that you have the items mentioned in the table below:

Table 19. Parts and Tools for Fixing Unit Bracket on RRH

Category	Description		
Parts	Unit Bracket		1 EA/RRH
	Fasteners	M6 x L20 hexagonal. bolt (Washer assembly)	4 EA/RRH
Recommended Torque Value	M6 hexagonal bolt		43 lbf-in
Working Tools	<ul style="list-style-type: none"> <li>• Torque Wrench (10 to 50 lbf-in)</li> <li>• Torque Wrench Spanner Head (apply Hex. head: 10 mm)</li> </ul>		

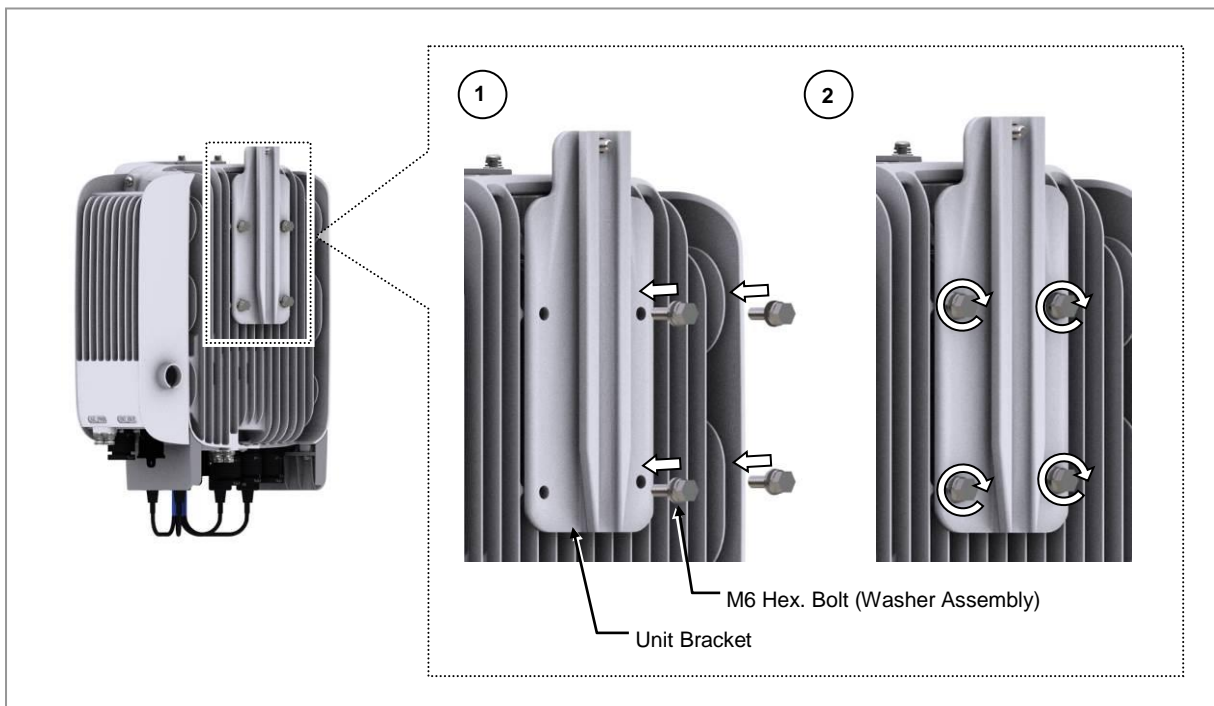
- 1 Check the position for mounting the unit bracket on the back of the RRH and place it in that position.

**Figure 53. Fixing Unit Bracket (1)**



2 Fix the unit bracket using the fasteners.

**Figure 54. Fixing Unit Bracket (2)**



**Fixing Pole Type**



Three RRHs can be installed when the pole diameter is than 8 in. (200 A, 220 mm) to 12 in. (300 A, 320 mm).



The length of the steel band is 930 mm, 1160 mm, and 1330 mm, and it is used

according to the pole diameter.

**Fixing Mounting Bracket for 3 Sector**

To fix the mounting bracket on the pole, do the following:

**Prerequisites**

Before proceeding with fixing the mounting bracket 3 sector pole type, make sure that you have the items mentioned in the table below:

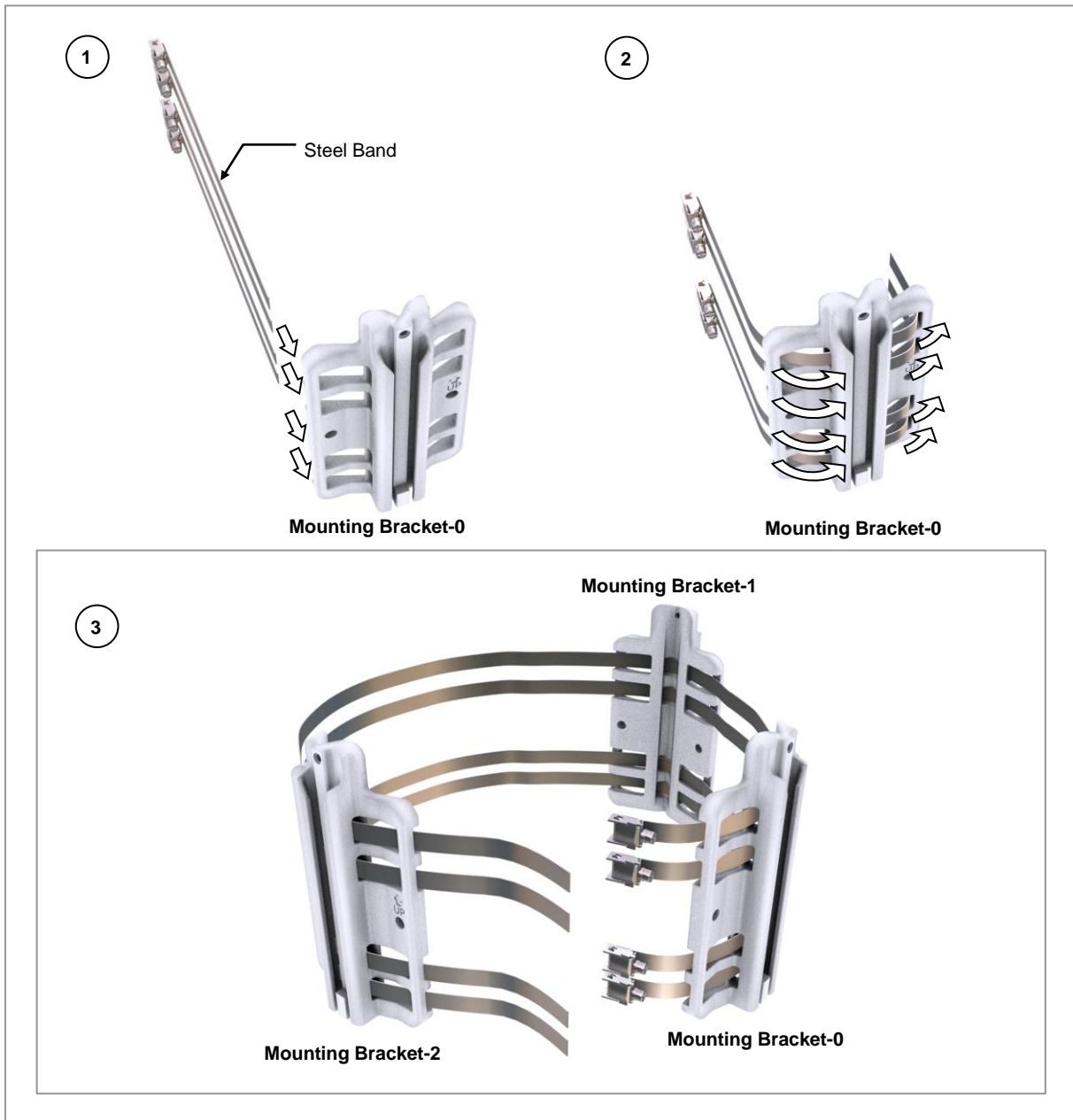
**Table 20. Parts and Tools for Fixing Mounting Bracket on the Pole**

Category	Description		
Parts	Mounting Bracket		3 EA
	Fasteners	Steel Band	4 EA
Recommended Torque Value	Steel Band Fixing Screw		110 lbf·in
Working Tools	<ul style="list-style-type: none"> <li>• Torque Driver (20 to 90 lbf·in)</li> <li>• Screw Driver Bit ('+', No. 3)</li> <li>• Antenna Alignment Tool</li> </ul>		

- 1 Pass the steel band through the fixing hole of the mounting brackets.

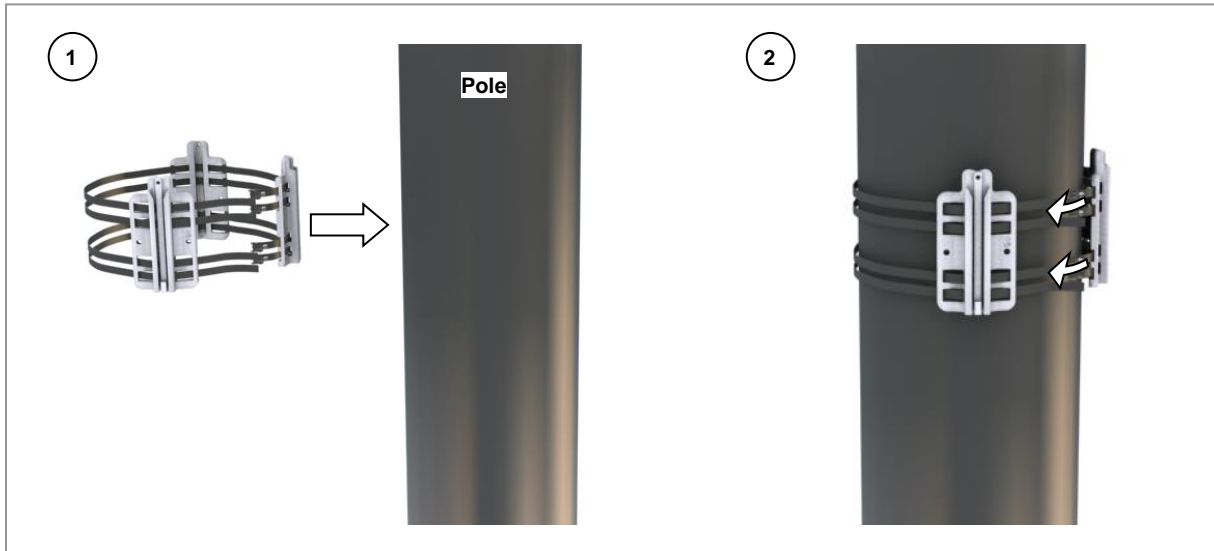


Figure 55. Fixing Mounting Bracket on the Pole (1)



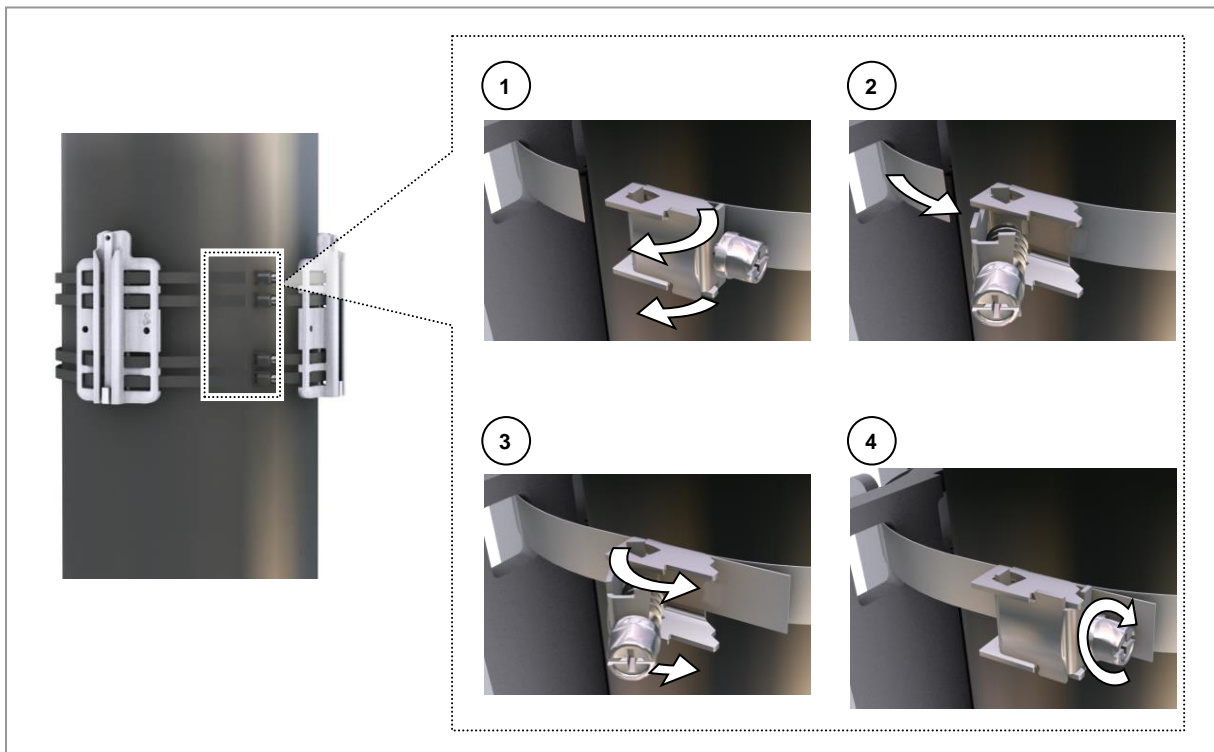
2 Place the mounting brackets to the pole.

*Figure 56. Fixing Mounting Bracket on the Pole (2)*



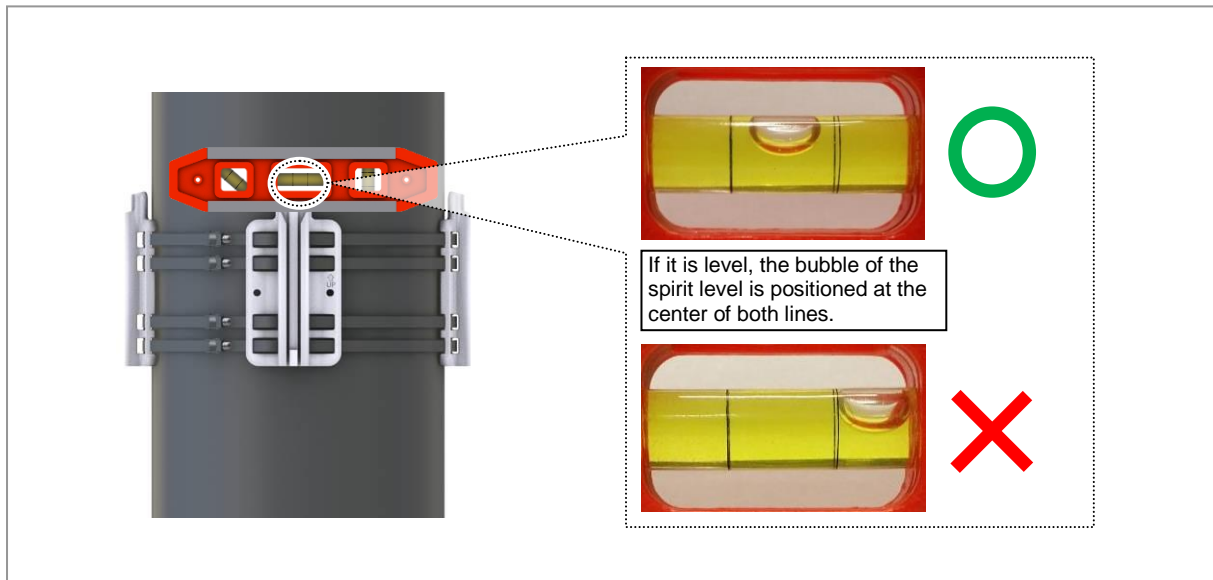
**3** Fix the mounting brackets to the pole using the steel band.




*Figure 57. Fixing Mounting Bracket on the Pole (3)*



**4** Check the level of each mounting brackets on the pole and adjust the level.

Figure 58. Fixing Mounting Bracket on the Pole (4)



-  When fixing the mounting bracket on the pole, ensure to check the level of bracket. After finishing the installation, adjust the level minutely.
-  When poor leveling happens, adjust the position of fasteners to fix the mounting bracket.
-  After fixing the steel band, push the remainder of band inside the mounting bracket

**Fixing RRUs on the Pole**

To fix the RRH on the pole, do the following:

**Prerequisites**

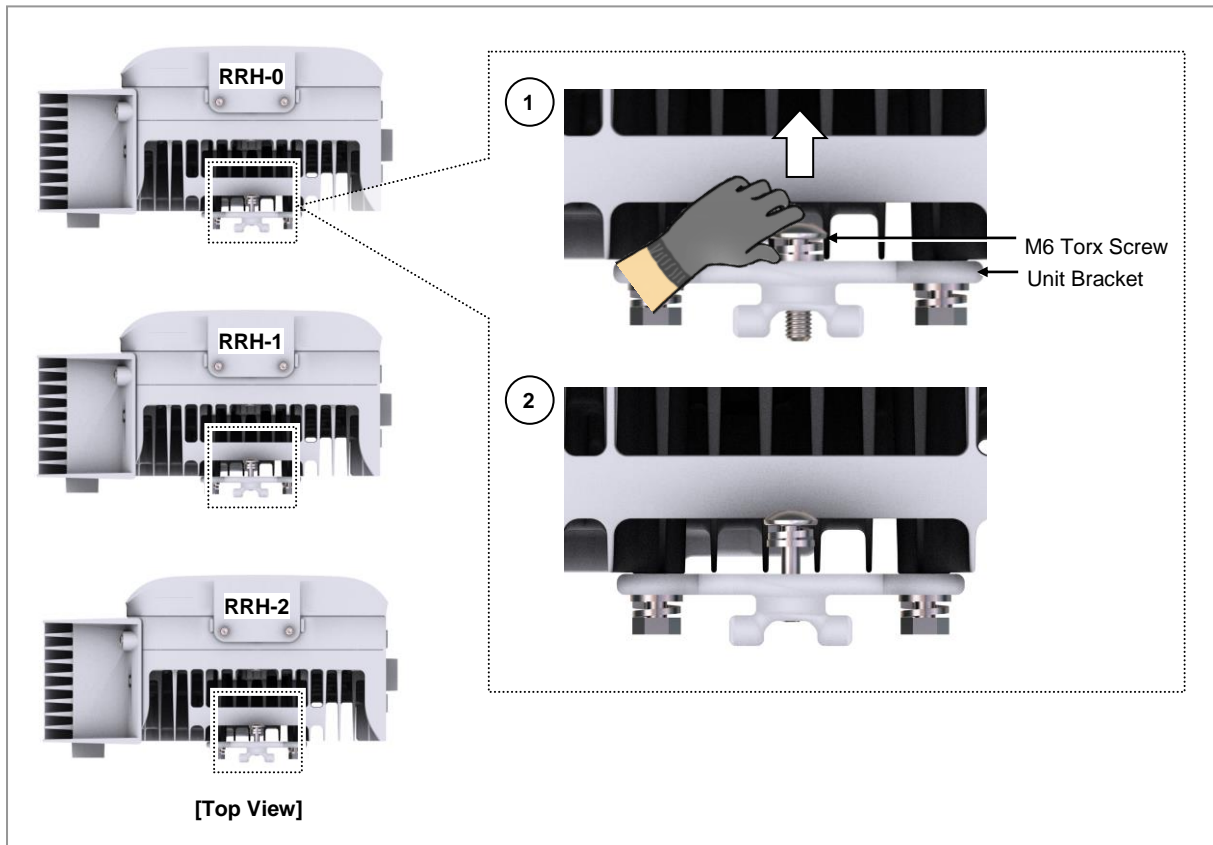
Before proceeding with fixing the RRH on the pole, make sure that you have the items mentioned in the table below:

Table 21. Tools for Fixing RRHs on the Pole

Category	Description
Recommended Torque Value	M6 Torx Screw 43 lbf-in
Working Tools	<ul style="list-style-type: none"> <li>• Torx Driver Bit (T30H)</li> <li>• Torque Driver (20 to 90 lbf-in)</li> <li>• Antenna Alignment Tool</li> </ul>

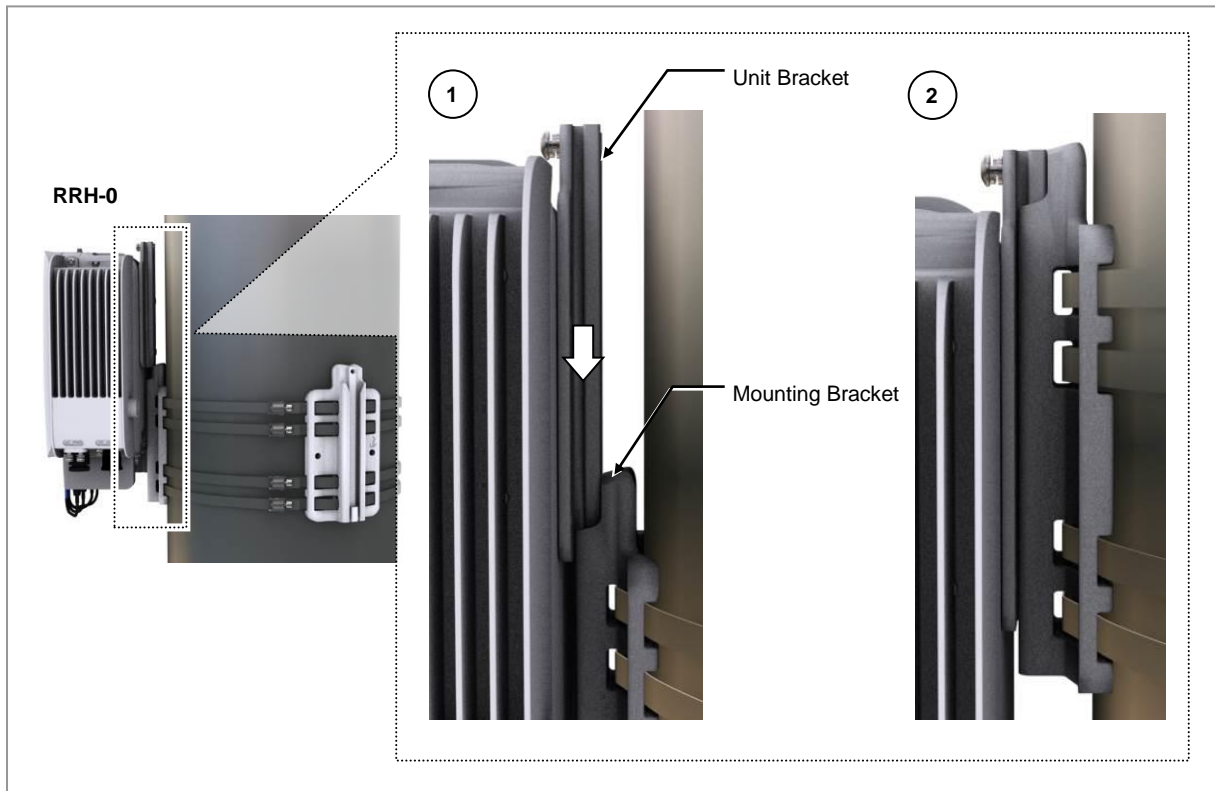
- 1 Pull out the fastening materials so that they do not extend out from the fixing groove of the unit bracket. Do not pull out completely.

Figure 59. Fixing RRHs on the Pole (1)



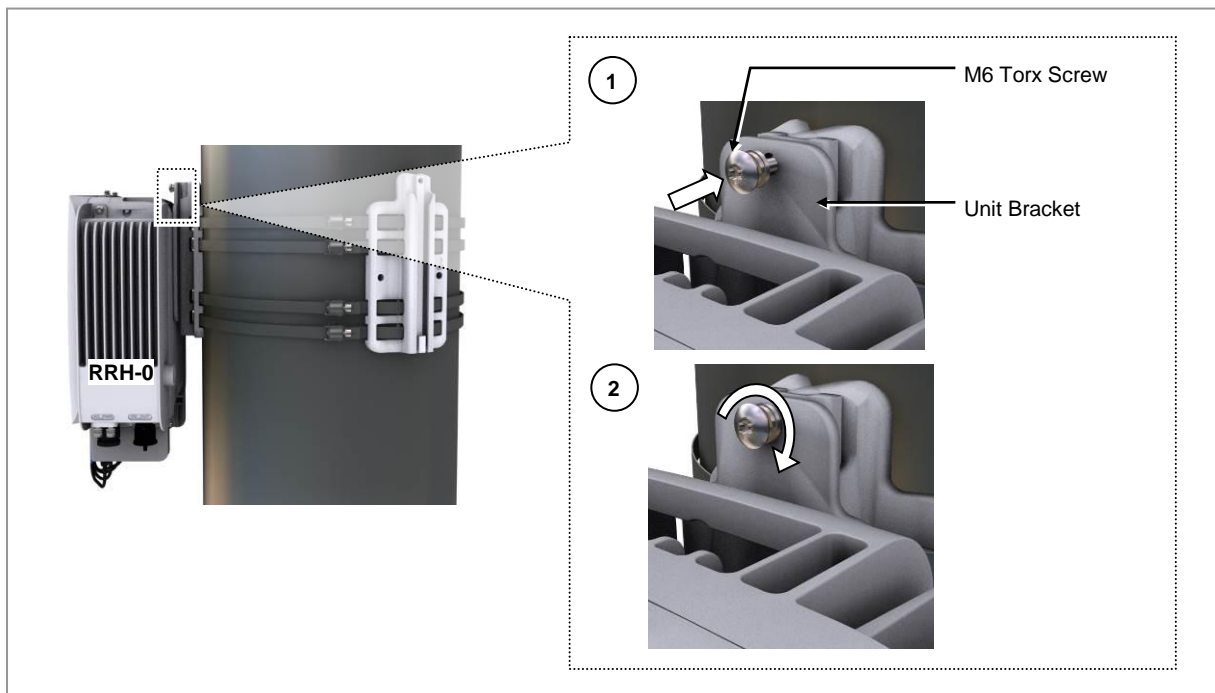
- 2 Place the unit bracket on the fixing grooves of the mounting bracket and push the unit bracket down to fix the RRH-0 in place.

Figure 60. Fixing RRHs on the Pole (2)



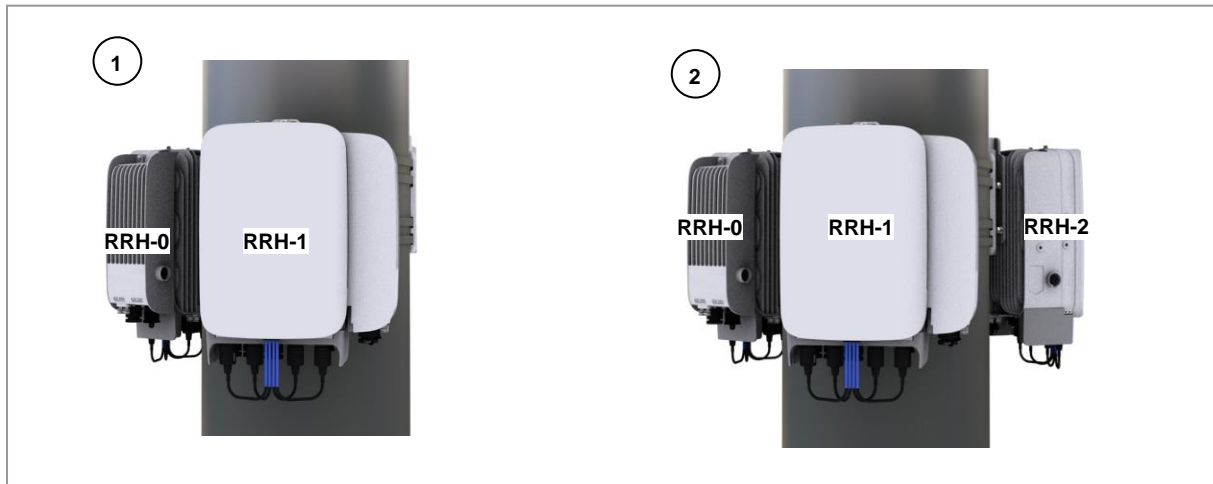
3 Fix the unit bracket of the RRH-0 to the mounting bracket using the fastener.

Figure 61. Fixing RRHs on the Pole (3)



- 4 Fix the RRH-1 and RRH-2 in the same way as the RRH-0.

**Figure 62. Fixing RRHs on the Pole (4)**



- 5 Check the tilt and the azimuth using the RF alignment tool and adjust when there is an issue.



For detailed instructions on how to use the RF alignment tool, refer to the user manual per manufacturer.

## Using Side by Side Bracket

This section describes the procedures to fix the side by side bracket.

### Fixing Unit Bracket

To fix the unit bracket, do the following:

#### Prerequisites

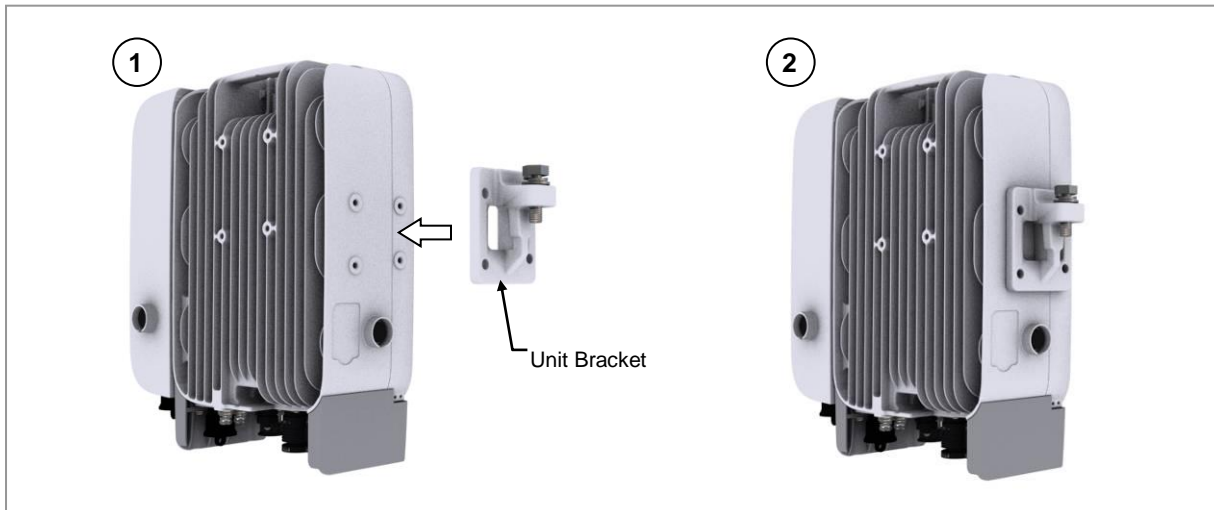
Before proceeding with fixing the unit bracket, make sure that you have the items mentioned in the table below:

**Table 22. Parts and Tools for Fixing Unit Bracket on RRH**

Category	Description	
Parts	Unit Bracket	
	Fasteners	M6 x L20 hexagonal. bolt (Washer assembly)
Recommended Torque Value	M6 hexagonal bolt	43 lbf-in
Working Tools	<ul style="list-style-type: none"> <li>• Torque Wrench (10 to 50 lbf-in)</li> <li>• Torque Wrench Spanner Head (apply hexagonal head: 10 mm)</li> <li>• Spanner (apply hexagonal head: 13 mm)</li> </ul>	

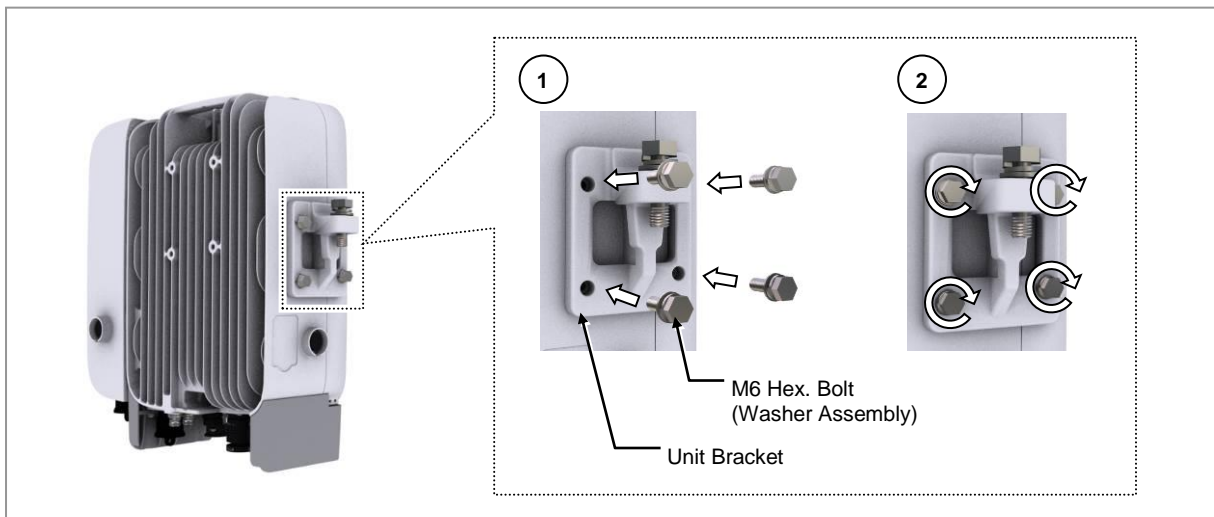
- 1 Place the unit bracket to the RRH left.

**Figure 63. Fixing Unit Bracket\_Side Installation (1)**



- 2 Fix the unit bracket using the fasteners.

**Figure 64. Fixing Unit Bracket\_Side Installation (2)**



**Fixing Pole Type\_Side by Side**

This section describes the procedures for fixing the system on the pole.



The standard of the pole on which the mounting bracket can be attached using steel bands is 50 A to 100 A.

**Assembling Mounting Bracket**

To assemble the mounting bracket for 1 sector, do the following:



**Prerequisites**

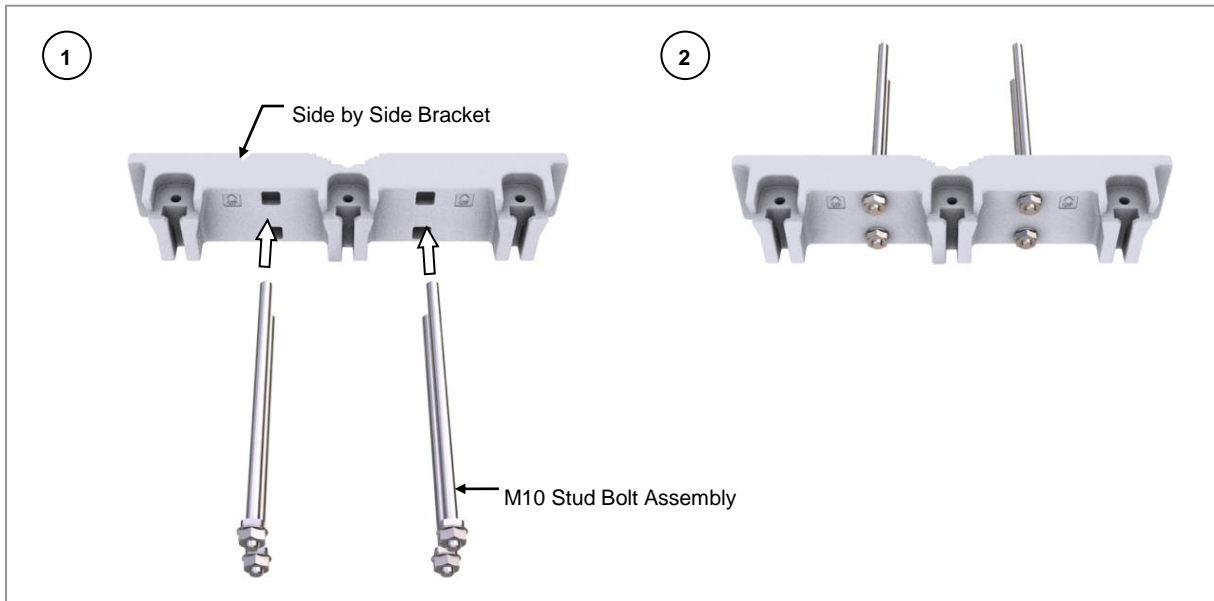
Before proceeding with assembling the side by side bracket, make sure that you have the items mentioned in the table below:

**Table 23. Parts and Tools for Fixing Side by Side Bracket on the Pole**

Category	Description		
Parts	Side by Side Bracket	1 EA	
	Rear Mounting Bracket	1 EA	
	Fasteners	• M10 × L220 Stud Bolt Assembly	4 EA
		• M10 Flange Nut	4 EA
• M10 Hexagonal Nut		4 EA	
Working Tools	Spanner (apply hexagonal. head: 17 mm)		

- 1 Insert the stud bolts to the fixing hole of side by side bracket assembly.

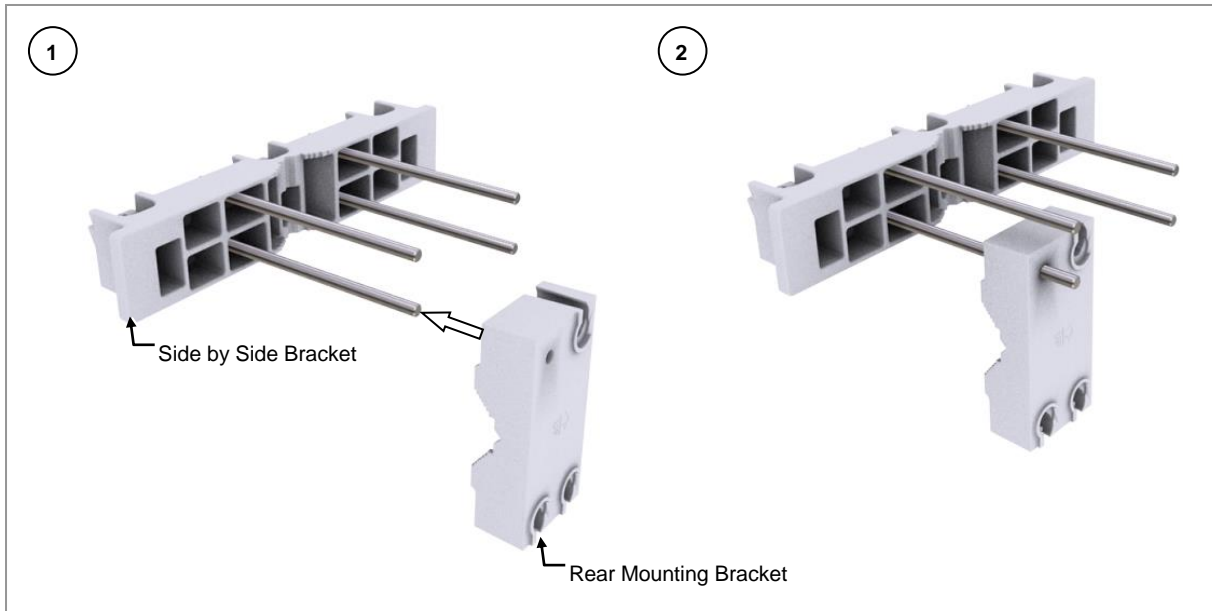
**Figure 65. Assembling Mounting Bracket Assembly\_Pole Type (1)**



- 2 Insert the rear mounting bracket with aligning the hole and stud bolt at the left lower side of side by side bracket.

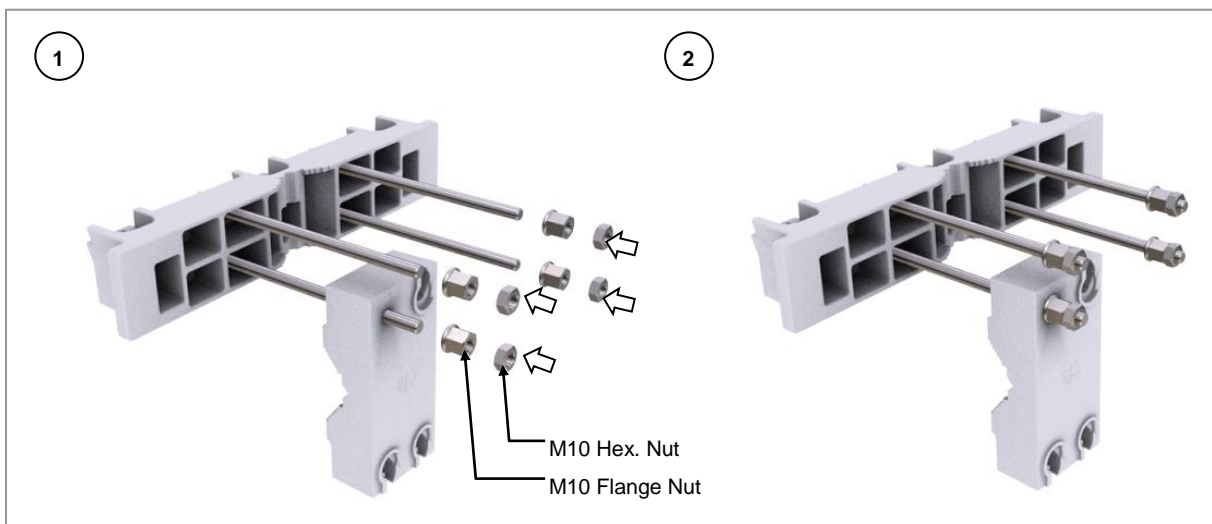


Figure 66. Assembling Mounting Bracket Assembly\_Pole Type (2)



3 Fix the fasteners to the stud bolts of side by side bracket.

Figure 67. Assembling Mounting Bracket Assembly\_Pole Type (3)



**Fixing Side by Side Bracket on the Pole**

To fix the side by side bracket on the wall, do the following:

**Prerequisites**

Before proceeding with fixing the side by side bracket for 3-sector on the pole, ensure that you have the items mentioned in the table below:

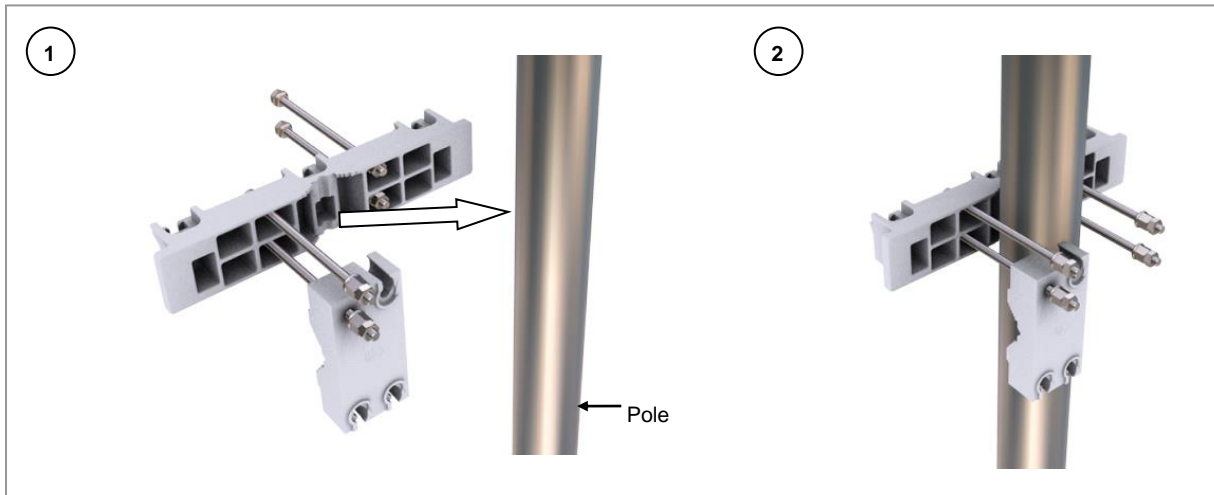
Table 24. Parts and Tools for Fixing Side by Side Bracket Assembly\_Pole Type

Category	Description	
Parts	Side by Side Bracket Assembly	1 EA

Category	Description	
Recommended Torque Value	M10 Flange Nut/M10 Hexagonal Nut	217 lb·in
Working Tools	Torque Wrench (100 to 400 lbf·in) Torque Wrench Spanner head (apply hexagonal. head: 17 mm) Spanner (17 mm) Level	

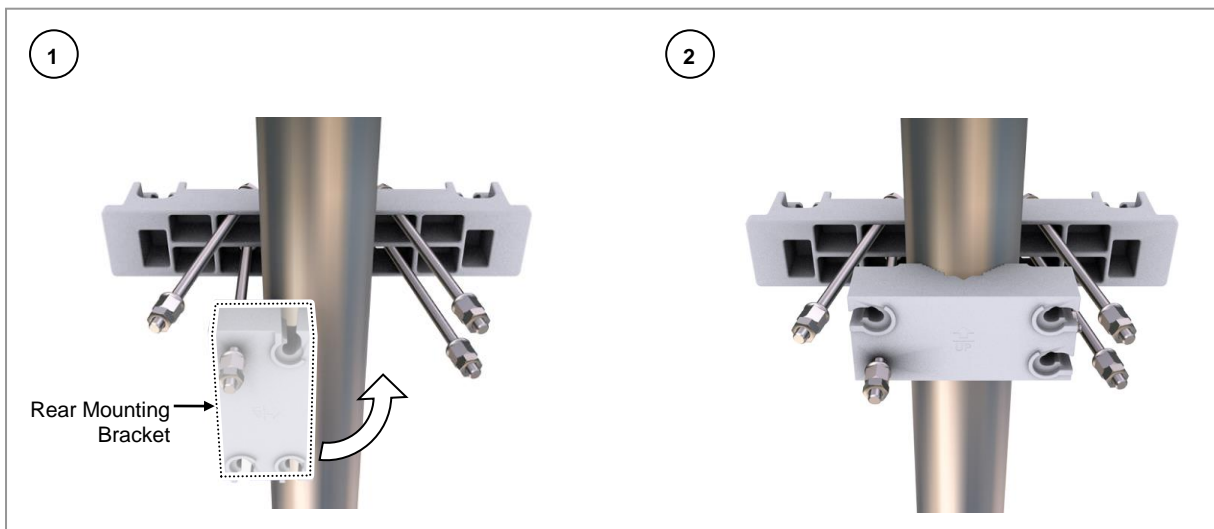
- 1 Place the side by side bracket assembly to the pole.

**Figure 68. Fixing Side by Side Bracket Assembly\_Pole Type (1)**



- 2 Locate a rear mounting bracket on a fixing location with the “Up” mark towards the upper side.

**Figure 69. Fixing Side by Side Bracket Assembly\_Pole Type (2)**



- 3 Place the rest three stud bolts to the rear mounting bracket holes and fix the stud bolts using the fasteners.