

# Nemko Korea Co., Ltd.

300-2, Osan-Ri, Mohyeon-Myeon, Cheoin-Gu, Yongin-Si, Gyeonggi-Do, KOREA

TEL:+82 31 322 2333 FAX:+82 31 322 2332

## FCC and IC EVALUATION REPORT FOR CERTIFICATION

### Applicant :

Samsung Electronics Co., Ltd.  
416, Maetan-3Dong, Yeongtong-Gu,  
Suwon-Si, Gyeonggi-Do, Korea.  
(Post code : 443-742)  
Attn. : Mr. Jaywoo. Lee

Dates of Issue : February 24, 2010  
Test Report No. : NK-10-R-005  
Test Site : Nemko Korea Co., Ltd.

FCC ID  
IC ID

Brand Name

Contact Person

**A3LRMC30C1**  
**649E-RMC30C1**

**SAMSUNG**

**Samsung Electronics Co., Ltd.**  
**416, Maetan-3Dog, Yeongtong-Gu,**  
**Suwon-Si, Gyeonggi-Do, Korea, 442-742.**  
**Mr. Jaywoo. Lee**  
**Telephone No. : +82-10-5691-9410**

Applied Standard: FCC 47 CFR Part 15C and IC RSS-210  
Classification: FCC part 15 Spread Spectrum Transmitter  
EUT Type: 3" TOUCH REMOTE

The device bearing the brand name and model specified above has been shown to comply with the applicable technical standards as indicated in the measurement report and was tested in accordance with the measurement procedures specified in ANSI C63.4-2003. The client should not use it to claim product endorsement by TAF or any government agencies. The test results in the report only apply to the tested sample.

I attest to the accuracy of data and all measurements reported herein were performed by me or were made under my supervision and are correct to the best of my knowledge and belief. I assume full responsibility for the completeness of these measurements and vouch for the qualifications of all persons taking them.



Feb. 24. 2010

Tested By : Minchul Shin  
Engineer



Feb. 24. 2010

Reviewed By : H.H. Kim  
Manager & Chief Engineer

Samsung Electronics Co., Ltd.

Page 1 of 101

FCC ID : A3LRMC30C1 / IC ID : 649E-RMC30C1

# TABLE OF CONTENTS

---

<b>1.</b>	<b>Scope</b>	<b>4</b>
<b>2.</b>	<b>Introduction (Site Description)</b>	<b>5</b>
<b>3.</b>	<b>Test Conditions &amp; EUT Information</b>	<b>6</b>
	3.1 Operation During Test	6
	3.2 Support Equipment	7
	3.3 Setup Drawing	7
	3.4 EUT Information	8
<b>4.</b>	<b>Summary of Test Results</b>	<b>9</b>
<b>5.</b>	<b>Recommendation / Conclusion</b>	<b>10</b>
<b>6.</b>	<b>Antenna Requirements</b>	<b>10</b>
<b>7.</b>	<b>Description of Test</b>	<b>11</b>
	7.1 Conducted Emissions	11
	7.2 Radiated Emissions	12
	7.3 6 dB Bandwidth	13
	7.4 Maximum Peak Output Power	13
	7.5 Peak Power Spectral Density	14
	7.6 Conducted Spurious Emissions	14
<b>8.</b>	<b>Test Data</b>	<b>15</b>
	8.1 Conducted Emissions	15
	8.2 Radiated Emissions	18
	8.3 6 dB Modulated Bandwidth	19
	8.4 Peak Power Output	27
	8.5 Power Spectral Density	29
	8.6 Conducted Spurious Emissions	37
	8.7 Radiated Spurious Emissions	54
	8.8 Receiver Spurious Emissions	77



<b>9</b>	<b>Accuracy of Measurement</b>	<b>78</b>
<b>10.</b>	<b>Test Equipment</b>	<b>80</b>
	<b>Appendix A: Labelling Requirement</b>	<b>81</b>
	<b>Appendix B: Photographs of Test Set-up</b>	<b>82</b>
	<b>Appendix C: EUT Photographs</b>	<b>84</b>

# 1. SCOPE

---

Measurement and determination of electromagnetic emissions (EME) of radio frequency devices including intentional and/or unintentional radiators for compliance with the technical rules and regulations of the Federal Communications Commission under FCC part 15 and IC RSS-210.

<b>Responsible Party :</b>	Samsung Electronics Co., Ltd.
<b>Contact Person :</b>	Mr. Jaywoo. Lee
<b>Manufacturer :</b>	Samsung Electronics Co., Ltd. 416 Maetan-3Dong, Yeongtong-Gu, Suwon-Si, Gyeonggi-Do, 443-742 KOREA

- FCC ID: A3LRMC30C1
- Model: RMC30C1
- Brand Name: SAMSUNG
- EUT Type: 3" TOUCH REMOTE
- Classification: FCC part 15 Spread Spectrum Transmitter
- Applied Standard: FCC 47 CFR Part 15 subpart C and IC RSS-210
- Test Procedure(s): ANSI C63.4 (2003)
- Dates of Test: Jan. 6, 2010 ~ Feb. 19, 2010
- Place of Tests: Nemko Korea Co., Ltd.

## 2. INTRODUCTION

The measurement procedure described in American National Standard for Methods of Measurement of Radio-Noise Emissions from Low-Voltage Electrical and Electronic Equipment in the Range of 9kHz to 40GHz (ANSI C63.4-2003) was used in determining radiated and conducted emissions emanating from **Samsung Electronics Co., Ltd.**

FCC ID : **A3LRMC30C1** and IC ID : **649E-RMC30C1**

These measurement tests were conducted at **Nemko Korea Co., Ltd. EMC Laboratory** . The site address is 300-2, Osan-Ri, Mohyeon-Myeon, Cheoin-Gu, Yongin-Si, Gyeonggi-Do, KOREA.

The area of Nemko Korea Corporation Ltd. EMC Test Site is located in a mountain area at 80 kilo-meters (48 miles) southeast and Incheon International Airport (Incheon Airport), 30 kilometers (18miles) south-southeast from central Seoul.

It is located in the valley surrounded by mountains in all directions where ambient radio signal conditions are quiet and a favorable area to measure the radio frequency interference on open field test site for the computing and ISM devices manufactures.

The detailed description of the measurement facility was found to be in compliance with the requirements of §2.948 according to ANSI C63.4 2003.



Nemko Korea Co., Ltd.  
EMC Lab.  
300-2, Osan-Ri, Mohyeon-Myeon, Cheoin-Gu, Yongin-Si, Gyeonggi-Do,  
KOREA 449-852  
Tel)+82-31-322-2333

Fig. 1. The map above shows the Seoul in Korea vicinity area.  
The map also shows Nemko Korea Corporation Ltd. EMC Lab. and Incheon Airport.

### 3. TEST CONDITIONS & EUT INFORMATION

#### 3.1 Operation During Test

The EUT was tested at the lowest channel, middle channel and the highest channel with the maximum RF power and all test data recorded in the report. During the test, the EUT was connected to notebook PC and then a test program supported by manufacturer was executed to operate EUT continuously.

The EUT is programmed with the following data rate setting that used during testing:

Test frequency		2412 MHz	2437 MHz	2462 MHz
802.11b	Power Level	17	17	17
	Data rate	11	11	11
802.11g	Power Level	14	14	14
	Data rate	54	54	54
802.11n(HT20)	Power Level	14	14	14
	Data rate	MCS0	MCS0	MCS0

Test frequency		2422 MHz	2437 MHz	2452 MHz
802.11n(HT40)	Power Level	12	14	12
	Data rate	MCS0	MCS0	MCS0

### 3.2 Support Equipment

3" TOUCH REMOTE (EUT)	Samsung Electronics Co., Ltd. FCC ID: A3LRMC30C1	S/N: N/A
TRAVEL ADAPTER	Dongyang E&P Model : ATADU19JBE 2.0 m shielded power cable	FCC Verification S/N: N/A
Earphone	N/A 0.8 m unshielded earphone cable	S/N: N/A

### 3.3 Setup Drawing

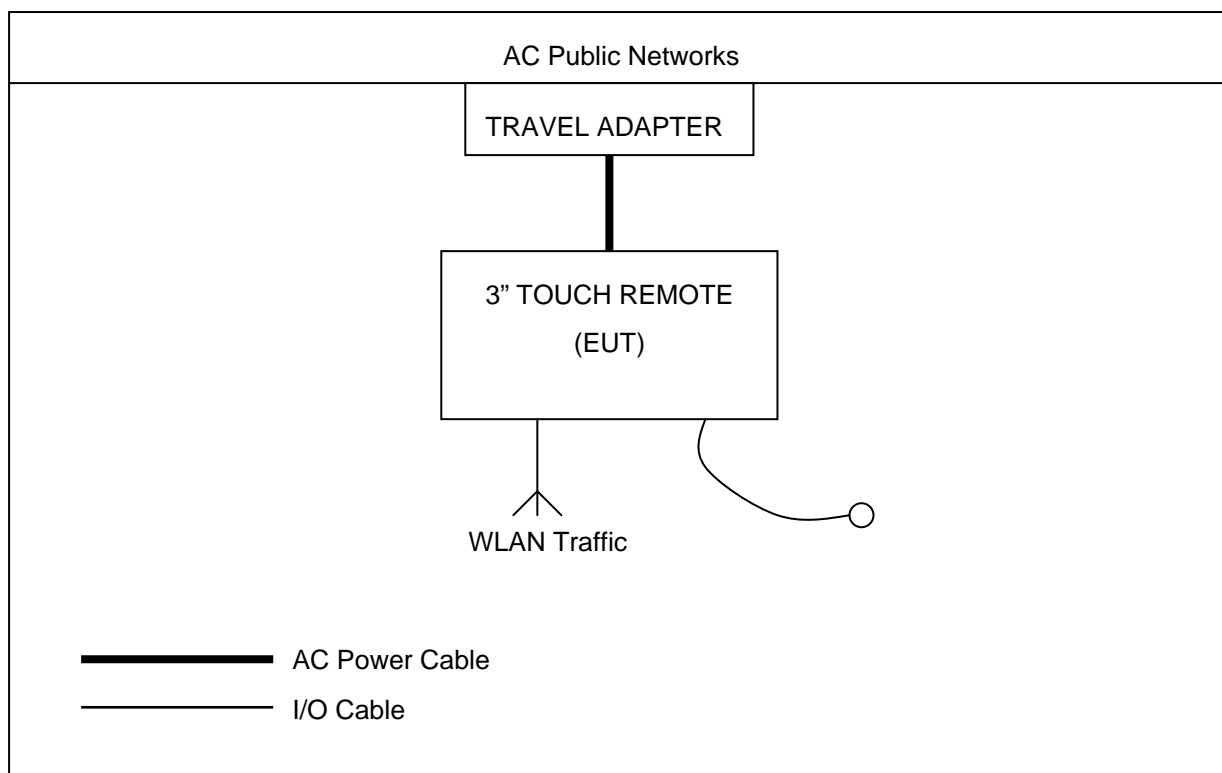

### 3.4 EUT Information

The EUT is the **Samsung 3" TOUCH REMOTE FCC ID: A3LRMC30C1, IC ID: 649E-RMC30C1.**

Specifications:

EUT Type	3" TOUCH REMOTE
Model Name	RMC30C1
Brand Name	SAMSUNG
Frequency of Operation	2412 MHz to 2462 MHz
Peak Power Output (Conducted)	802.11b : 16.23 dBm 802.11g : 15.67 dBm 802.11n(HT20) : 14.64 dBm 802.11n(HT40) : 13.39 dBm
Channels	802.11b,g,n(HT20) : 11 CH 802.11n(HT40) : 9 CH
Antenna Gain	-0.473 dBi
Spreading	DSSS, OFDM
Modulations	BPSK, QPSK, 16QAM, 64QAM
Temperature Range	0 °C ~ +35 °C
Voltage	DC 3.7 V
Dimension(W x D x H)	58 mm x 157 mm x 12 mm
Weight	95 g
Remarks	-

## 4. SUMMARY OF TEST RESULTS

---

The EUT has been tested according to the following specification:

Name of Test	FCC Paragraph No.	IC Paragraph No.	Result	Remark
Conducted Emission	15.207	RSS-GEN	Complies	
Radiated Emission	15.205 15.209	RSS-210 Clause 2.6, RSS-GEN Clause 6	Complies	
6 dB Bandwidth	15.247(a)(2)	RSS-210 A8.2 (a)	Complies	
Peak Power Output	15.247(b)(3)	RSS-210 Issue 7 Clause A8.4	Complies	
Power Spectral Density	15.247(e)	RSS-210 Clause A8.2	Complies	
Conducted Spurious Emission	15.247(d)	IC RSS-210 A8.5	Complies	
Radiated Spurious Emission	15.247(d)	RSS-210 Clause 2.6, RSS-GEN Clause 6	Complies	

## 5. RECOMMENDATION/CONCLUSION

---

The data collected shows that the **Samsung 3" TOUCH REMOTE FCC ID: A3LRMC30C1, IC ID: 649E-RMC30C1** is in compliance with Part 15 Subpart C 15.247 of the FCC Rules.

## 6. ANTENNA REQUIREMENTS

---

### §15.203 of the FCC Rules part 15 Subpart C

: An intentional radiator shall be designed to ensure that no antenna other than that furnished by the responsible party shall be used with the device. The use of a permanently attached antenna or of an antenna that uses a unique coupling to the intentional radiator shall be considered sufficient to comply with the provisions of this section.

The antenna of the **Samsung 3" TOUCH REMOTE FCC ID: A3LRMC30C1, IC ID: 649E-RMC30C1** is **permanently attached** and there are no provisions for connection to an external antenna. It complies with the requirement of §15.203.

## 7. DESCRIPTION OF TESTS

### 7.1 Conducted Emissions

The Line conducted emission test facility is located inside a 4 X 7 X 2.5 meter shielded enclosure.

It is manufactured by EM engineering. The shielding effectiveness of the shielded room is in accordance with MIL-STD-285 or NSA 65-6.

A 1m X 1.5m wooden table 0.8m height is placed 0.4m away from the vertical wall and 1.5m away from the side of wall of the shielded room Rohde & Schwarz (ESH3-Z5) and Kyoritsu (KNW-407) of the 50ohm/50uH Line Impedance Stabilization Network(LISN) are bonded to the shielded room.

The EUT is powered from the Rohde & Schwarz LISN and the support equipment is powered from the Kyoritsu LISN. Power to the LISNs are filtered by high-current high insertion loss Power line filters. The purpose of filter is to attenuate ambient signal interference and this filter is also bonded to shielded enclosure. All electrical cables are shielded by tinned copper zipper tubing with inner diameter of 1/2".

If DC power device, power will be derived from the source power supply it normally will be powered from the supply lines will be connected to the LISNs, All interconnecting cables more than 1 meter were shortened by non inductive bundling (serpentine fashion) to a 1 meter length.

Sufficient time for EUT, support equipment, and test equipment was allowed in order for them to warm up to their normal operating condition. The RF output of the LISN was connected to the spectrum analyzer to determine the frequency producing the maximum EME from the EUT.

The spectrum was scanned from 150 kHz to 30 MHz with 200 msec sweep time.

The frequency producing the maximum level was re-examined using the EMI test receiver. (Rohde & Schwarz ESCS30).

The detector function were set to CISPR quasi-peak mode & average mode.

The bandwidth of receiver was set to 9KHz. The EUT, support equipment, and interconnecting cables were arranged and manipulated to maximize each EME emission.

Each emission was maximized by; switching power lines; varying the mode of operation or resolution; clock or data exchange speed; scrolling H pattern to the EUT and of support equipment, and powering the monitor from the floor mounted outlet box and computer aux AC outlet, if applicable; which ever determined the worst case emission.

Each EME reported was calibrated using the R&S signal generator.

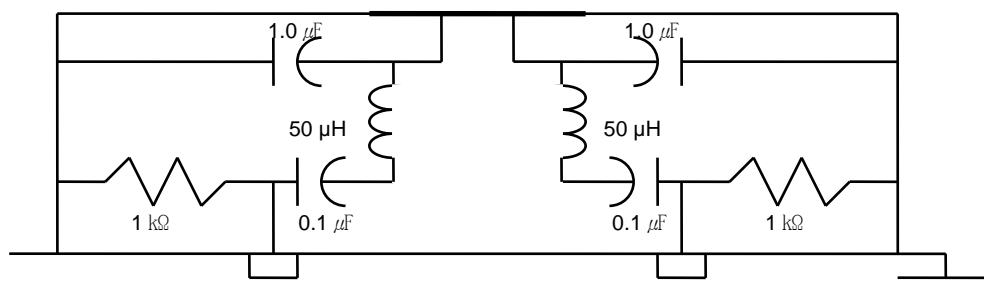

Fig. 2. LISN Schematic Diagram

## 7.2 Radiated Emissions

Preliminary measurement were made indoors at 3 meter using broad band antennas, broadband amplifier, and spectrum analyzer to determine the frequency producing the maximum EME. Appropriate precaution was taken to ensure that all EME from the EUT were maximized and investigated. The Technology configuration, clock speed, mode of operation or video resolution, turntable azimuth with respect to the antenna was note for each frequency found. The spectrum was scanned from 9 kHz to 30 MHz using Loop Antenne(EMCO, 6502) and 30 to 1000 MHz using Bi-conical log Antenna(ARA, LPB-2520/A). Above 1 GHz, Horn antenna (Scwarzbeck BBHA 9120D: upto 18 GHz , BBHA9170 : upto 40 GHz) was used. Final Measurements were made outdoors at 3 or 10 m test range using Loop Antenne(EMCO, 6502) and Logbicon Super Antenna (Schwarzbeck, VULB9166) or Horn antenna.(Scwarzbeck BBHA 9120D: upto 18 GHz , BBHA9170 : upto 40 GHz).

The test equipment was placed on a wooden table. Sufficient time for the EUT, support equipment, and test equipment was allowed in order for them to warm up to their normal operating condition.

Each frequency found during pre-scan measurements was reexamined and investigated using EMI test receiver.(ESCS30) The detector function was set to CISPR peak mode or quasi-peak mode or average mode and the band-width of the receiver was set to 120 kHz or 1MHz depending on the frequency or type of signal. The half wave dipole antenna was tuned to the frequency found during preliminary radiated measurements. The EUT support equipment and interconnecting cables were re configured to the setup producing the maximum emission for the frequency and were placed on top of a 0.8 m high non- metallic 1.0 X 1.5 meter table. The EUT, support equipment and interconnecting cables were re-arranged and manipulated to maximize each EME emission. The turn table containing the Technology was rotated; the antenna height was varied 1 to 4meter and stopped at the azimuth or height producing the maximum emission Each emission was maximized by : switching power lines; varying the mode of operation or resolution; clock or data exchange speed; scrolling H pattern to the EUT and of support equipment, and powering the monitor from the floor mounted outlet box and computer aux AC outlet, if applicable; which ever determined the worst case emission.

Each EME reported was calibrated using the R/S signal generator.

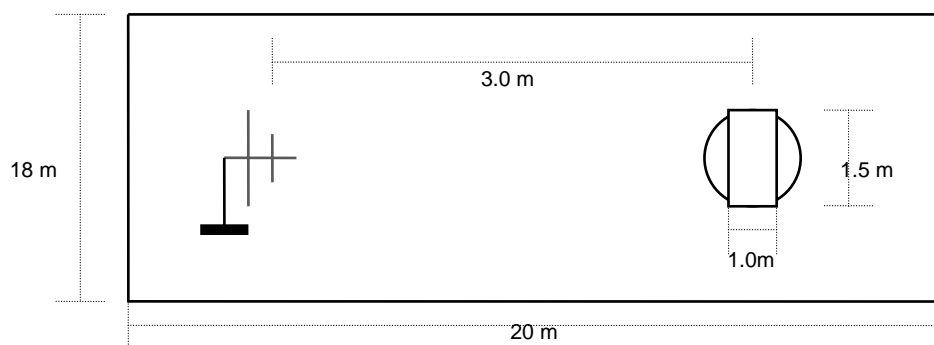
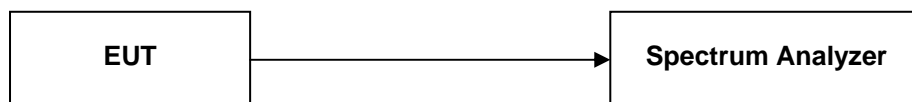

Fig. 3. Dimensions of Outdoor Test Site

### 7.3 6 dB Bandwidth

#### Test Setup



#### Test Procedure

The transmitter is set to the Low, Middle, High channels connected to the spectrum analyzer. The RBW and VBW of spectrum analyzer are set to 100 kHz.

The sweep time is coupled.

### 7.4 Maximum Peak Output Power

#### Test Setup

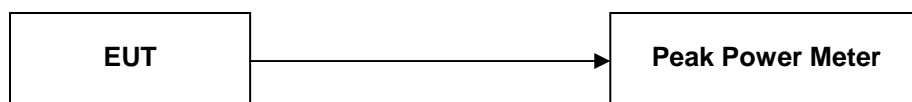

#### Test Procedure

The transmitter is set to the Lowest, Middle, Highest channels connected to the Peak Power Meter.

## 7.5 Peak Power Spectral Density

### Test Setup

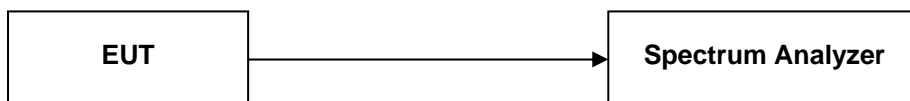

### Test Procedure

The transmitter is connected to the Spectrum analyzer.

The maximum level in a 3 kHz bandwidth is measured with the spectrum analyzer.

The RBW of spectrum analyzer is set to 3 kHz and VBW is set to 3 kHz.

The sweep time is set to Span/3 kHz and video averaging is turned off.

The PPSD is the highest level found across the emission in any 3 kHz band.

## 7.6 Conducted Spurious Emissions

### Test Setup

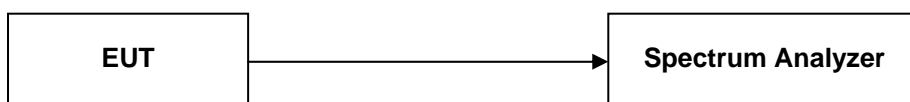

### Test Procedure

The transmitter is connected to the spectrum analyzer.

The RBW of spectrum analyzer is set to 1 MHz and VBW is set to the 1 MHz.

Measurements are made over the 30 MHz to 25 GHz range with the transmitter set to the Lowest, Middle and highest channels.

## 8. TEST DATA

### 8.1 Conducted Emissions

FCC §15.207. 15.107

Frequency (MHz)	Level(dB $\mu$ V)		*)Factor (dB)	**) Line	Limit(dB $\mu$ V)		Margin(dB)	
	Q-Peak	Average			Q-Peak	Average	Q-Peak	Average
0.38	40.2	33.7	0.1	L	58.3	48.3	18.1	14.6
0.59	38.8	25.8	0.1	N	56.0	46.0	17.2	20.2
2.02	43.5	31.2	0.3	N	56.0	46.0	12.5	14.8
2.36	43.1	32.0	0.3	N	56.0	46.0	12.9	14.0
2.48	43.6	32.1	0.3	N	56.0	46.0	12.4	13.9
2.70	42.7	32.5	0.3	N	56.0	46.0	13.3	13.5

**Line Conducted Emissions Tabulated Data**

**NOTES:**

1. Measurements using CISPR quasi-peak mode & average mode.
2. All modes of operation were investigated and the worst -case emission are reported.  
See attached Plots.
3. Factor = LISN + Cable Loss
4. LINE : L =Line , N = Neutral
5. The limit is on the FCC Part section 15.207(a), 15.107(a).

# PLOTS OF EMISSIONS

● **Conducted Emission at the Mains port (Line)**

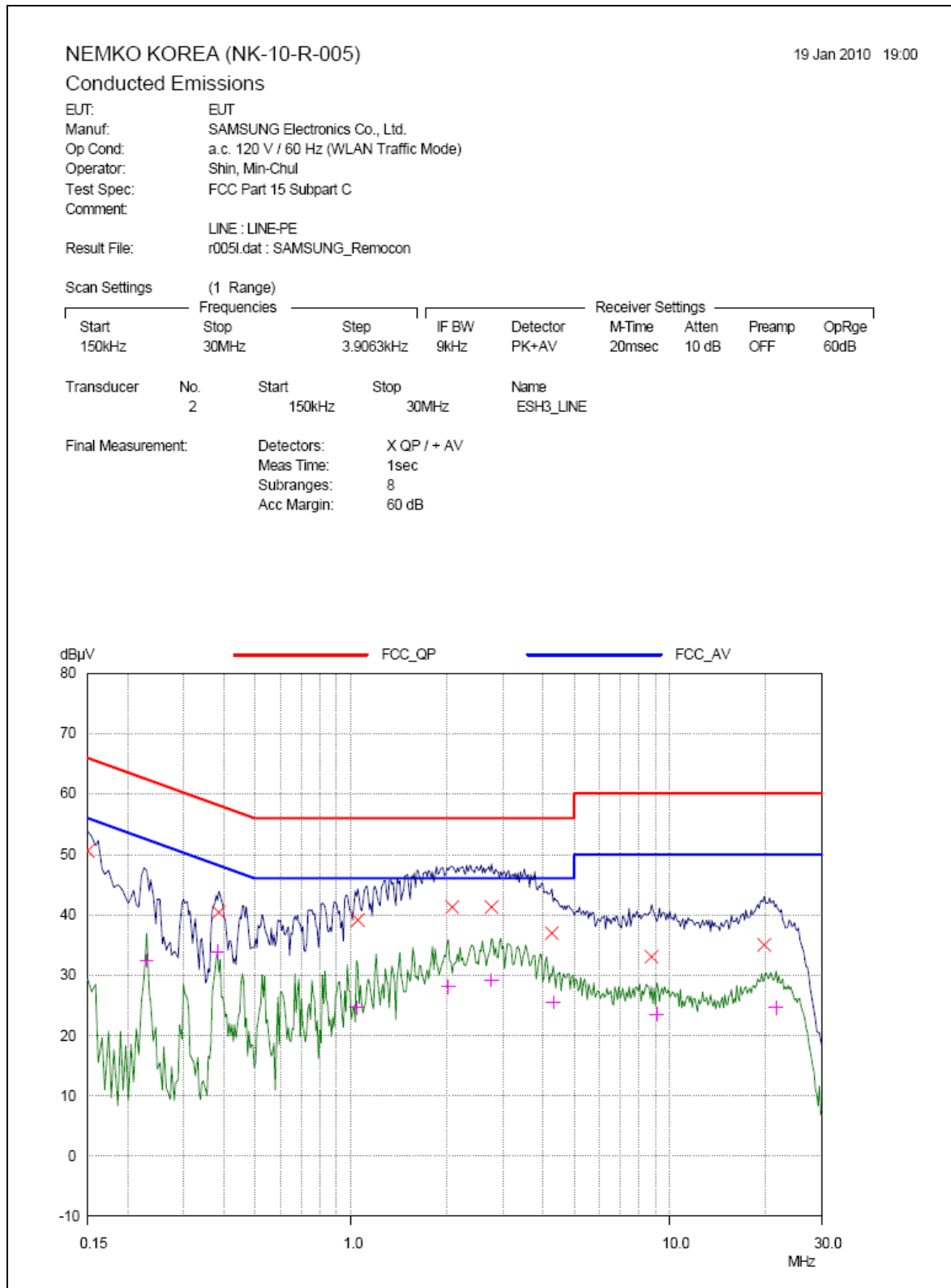

# PLOTS OF EMISSIONS

- Conducted Emission at the Mains port (Neutral)

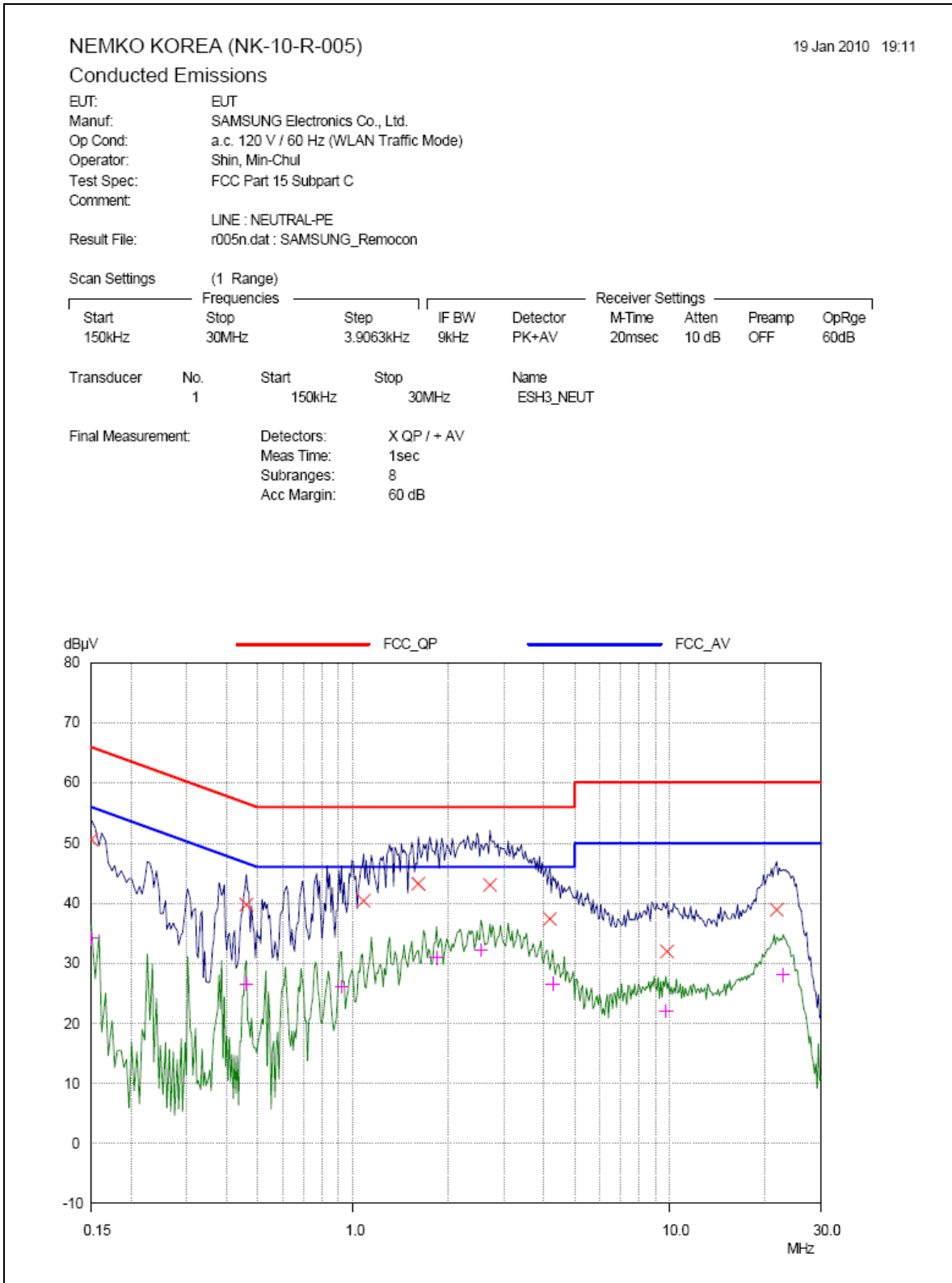

# TEST DATA

## 8.2 Radiated Emissions

FCC §15.209, 15. 205, IC RSS-210 Clause 2.6, IC RSS-GEN Clause 6

Frequency (MHz)	Reading (dB $\mu$ V/m)	Pol* (H/V)	AF+CL+Amp (dB)**	Result (dB $\mu$ V/m)	Limit (dB $\mu$ V/m)	Margin (dB)
329.98	53.6	H	-13.6	40.0	46.0	6.0
359.98	52.6	H	-13.6	39.0	46.0	7.0
383.98	46.0	H	-13.6	32.4	46.0	13.6
407.98	53.6	H	-11.1	42.5	46.0	3.5
431.98	50.2	H	-11.1	39.1	46.0	6.9
989.95	36.6	H	-1.3	35.3	46.0	10.7

Radiated Measurements at 3meters

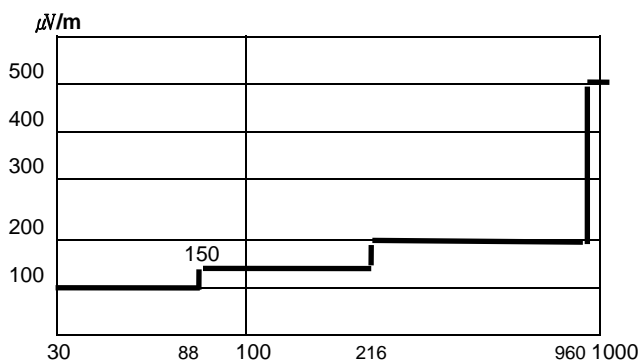

Fig. 4. Limits at 3 meters

**NOTES:**

1. All modes were measured and the worst-case emission was reported.
  - 2 The radiated limits are shown on Figure 4.
- Above 1GHz the limit is 500  $\mu$ V/m.

MHz

1. \*Pol. H=Horizontal, V=Vertical
2. \*\*AF+CL+Amp. = Antenna Factor + Cable Loss + Amplifier.
3. Measurements using CISPR quasi-peak mode.
4. The radiated emissions testing were made by rotating through three orthogonal axes.  
The worst date was recorded.
5. The limit is on the FCC Part section 15.109(a), 15.209(a).

## TEST DATA

---

### 8.3 6 dB Modulated Bandwidth

FCC §15.247(a), IC RSS-210 A8.1(b)

Test Mode : Set to Lowest channel, Middle channel and Highest channel

Result:

#### 802.11b mode

Channel	Frequency(MHz)	Result(MHz)	Limit(MHz)
Low	2412	11.56	0.5
Middle	2437	11.71	0.5
High	2462	11.55	0.5

#### 802.11g mode

Channel	Frequency(MHz)	Result(MHz)	Limit(MHz)
Low	2412	16.62	0.5
Middle	2437	16.61	0.5
High	2462	16.61	0.5

#### 802.11n (HT20) mode

Channel	Frequency(MHz)	Result(MHz)	Limit(MHz)
Low	2412	17.78	0.5
Middle	2437	17.75	0.5
High	2462	17.78	0.5

## TEST DATA

---

### 802.11n (HT40) mode

Channel	Frequency(MHz)	Result(MHz)	Limit(MHz)
Low	2422	36.55	0.5
Middle	2437	36.62	0.5
High	2452	36.63	0.5

**PLOTS OF EMISSIONS**

**802.11b mode**

**6 dB Bandwidth, 802.11b mode, Lowest Channel**

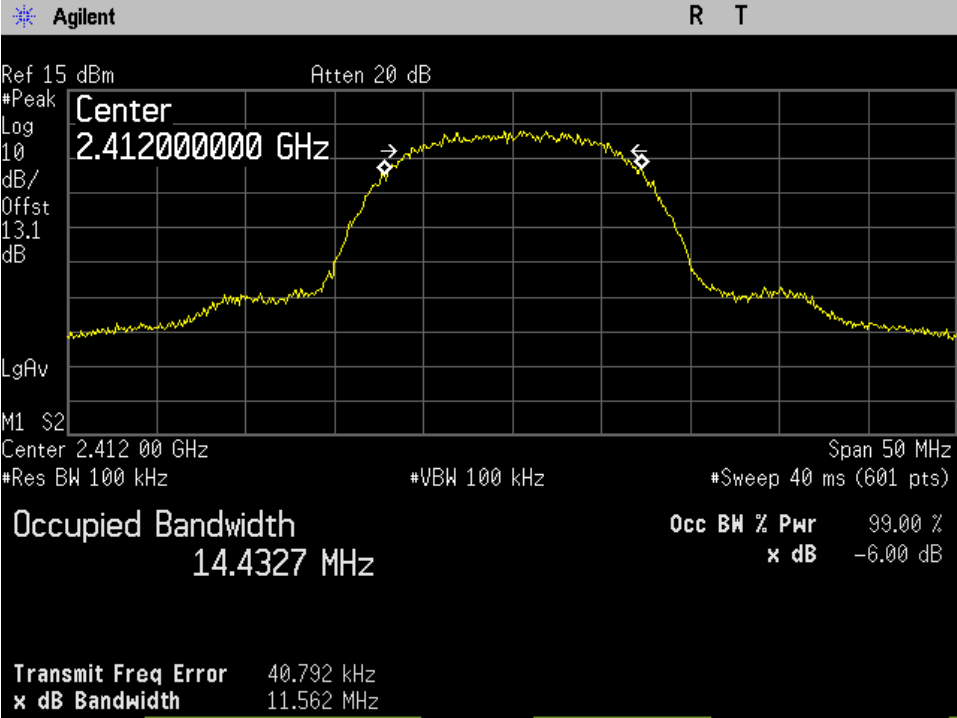

**6 dB Bandwidth, 802.11b mode, Middle Channel**

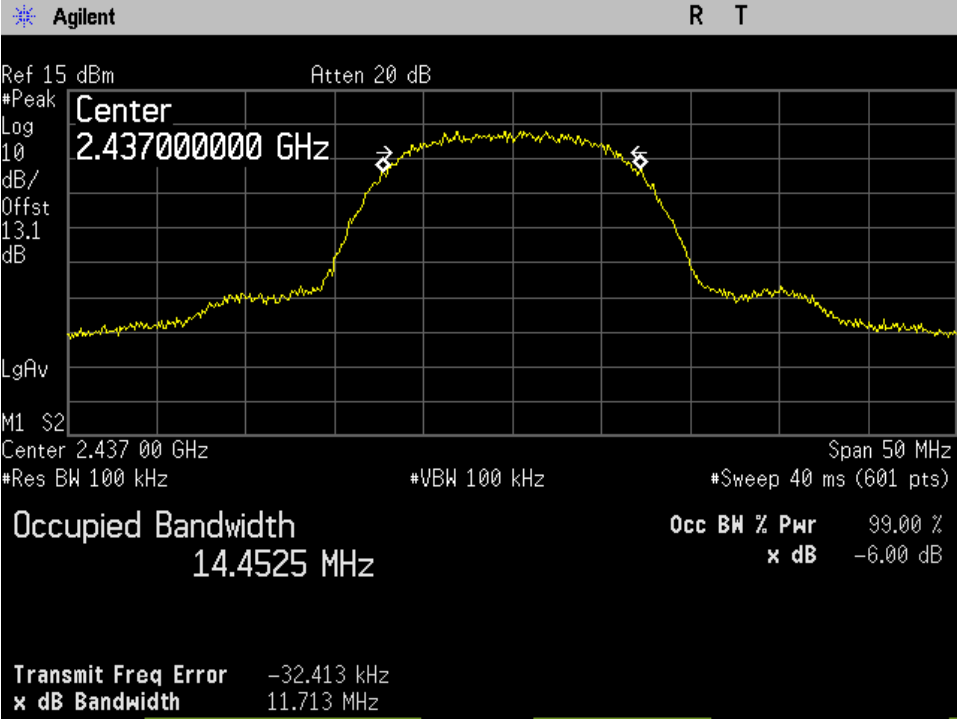

**PLOTS OF EMISSIONS**

**6 dB Bandwidth, 802.11b mode, Highest Channel**

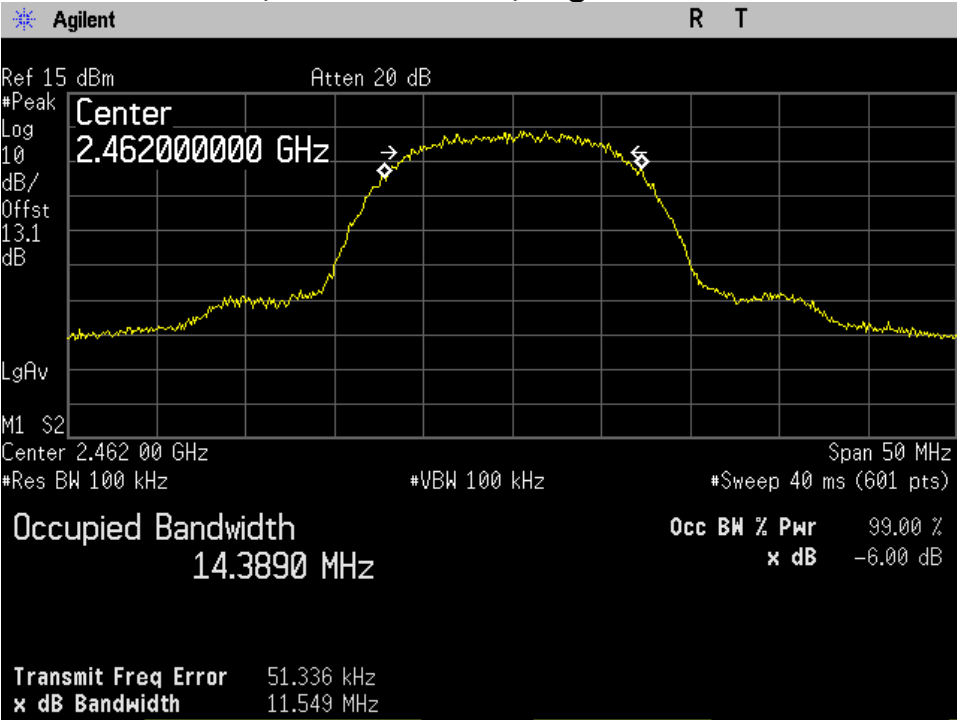

**802.11g mode**

**6 dB Bandwidth, 802.11g mode, Lowest Channel**

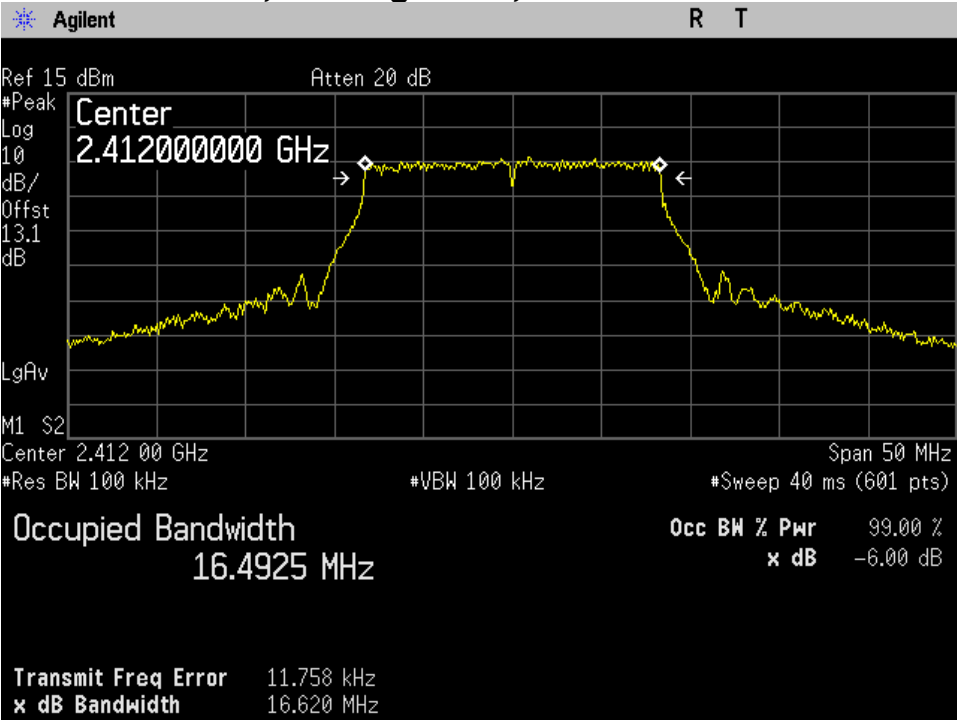

# PLOTS OF EMISSIONS

## 6 dB Bandwidth, 802.11g mode, Middle Channel

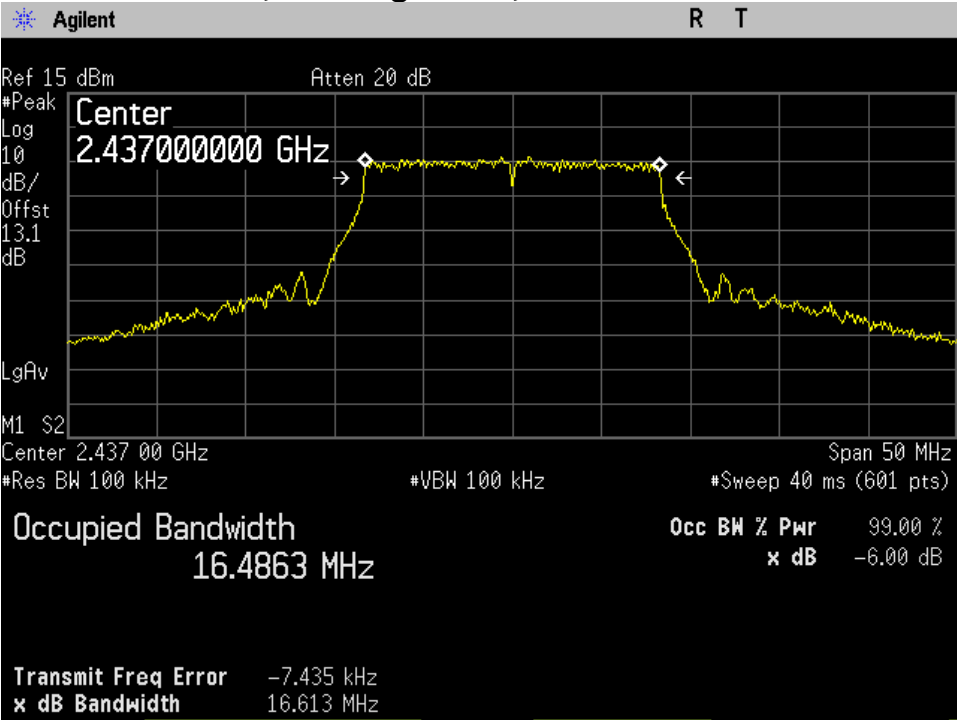

## 6 dB Bandwidth, 802.11g mode, Highest Channel

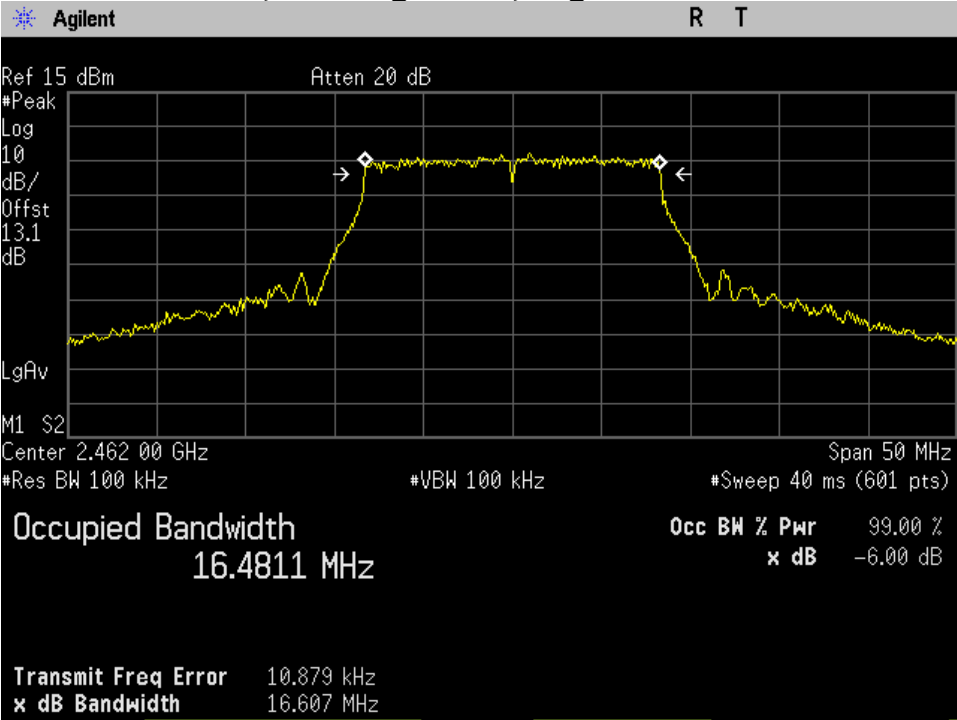

# PLOTS OF EMISSIONS

**802.11n(HT20) mode**

**6 dB Bandwidth, 802.11n(HT20) mode, Lowest Channel**

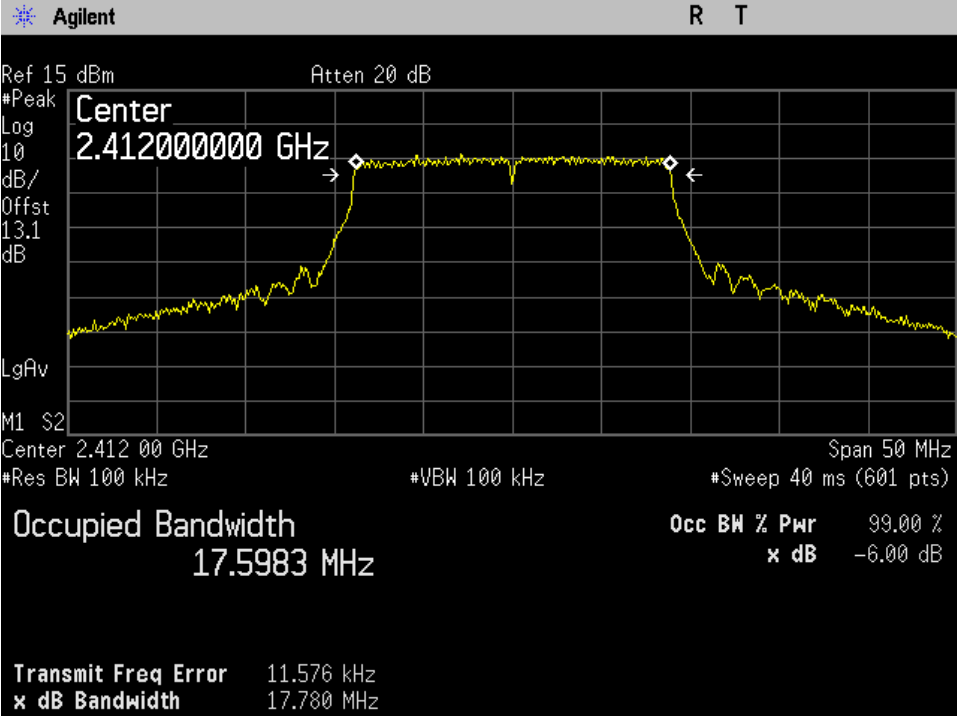

**6 dB Bandwidth, 802.11n(HT20) mode, Middle Channel**

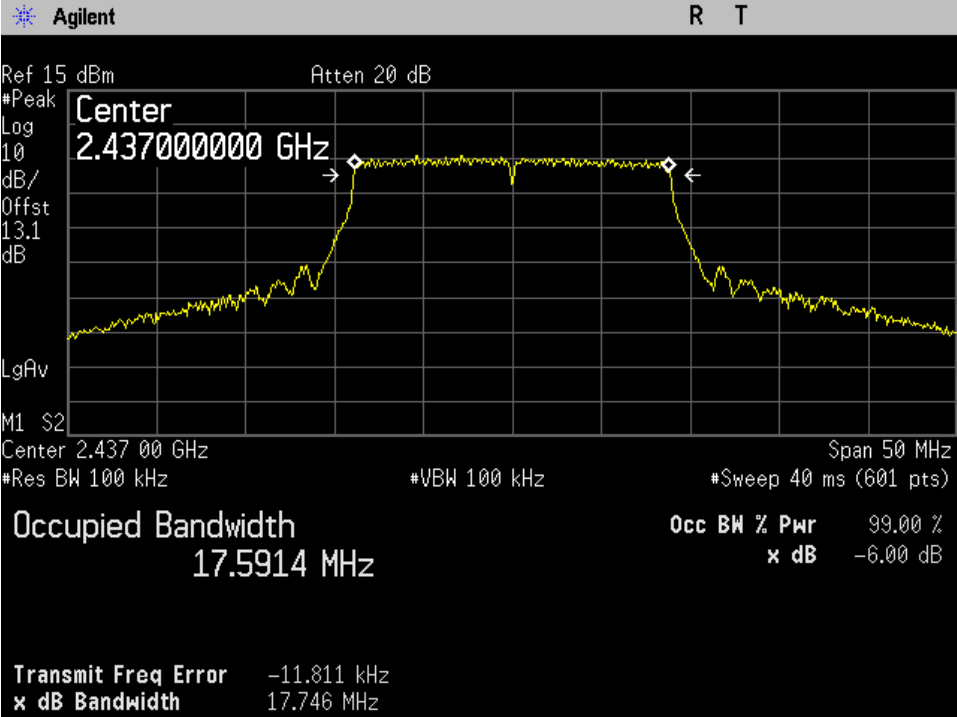

# PLOTS OF EMISSIONS

## 6 dB Bandwidth, 802.11n(HT20) mode, Highest Channel

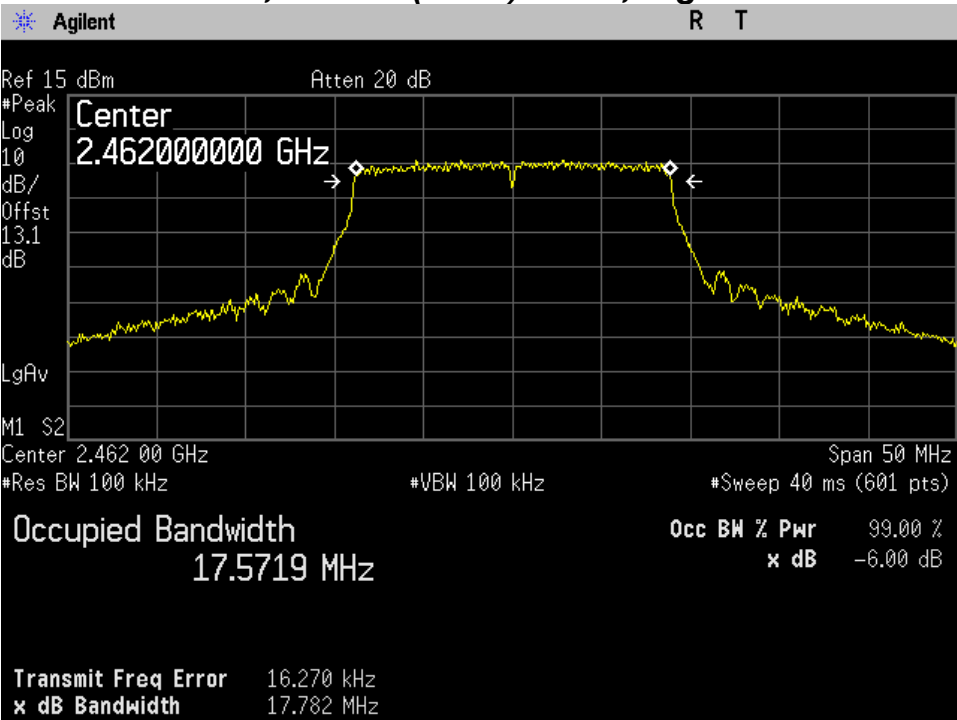

## 802.11n(HT40) mode

### 6 dB Bandwidth, 802.11n(HT40) mode, Lowest Channel

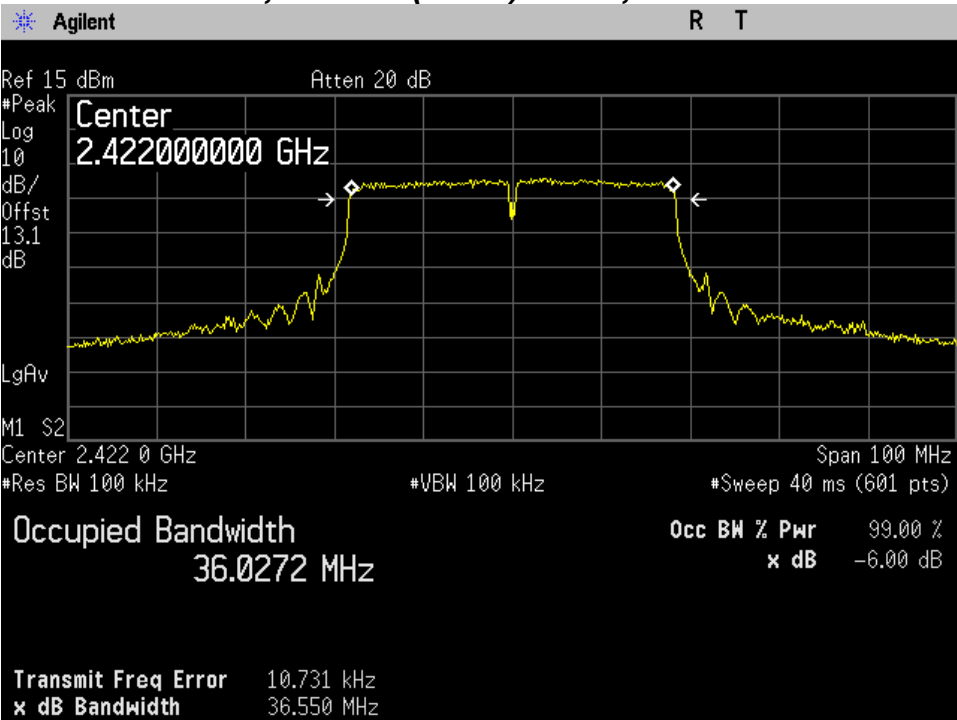

**PLOTS OF EMISSIONS**

**6 dB Bandwidth, 802.11n(HT40) mode, Middle Channel**

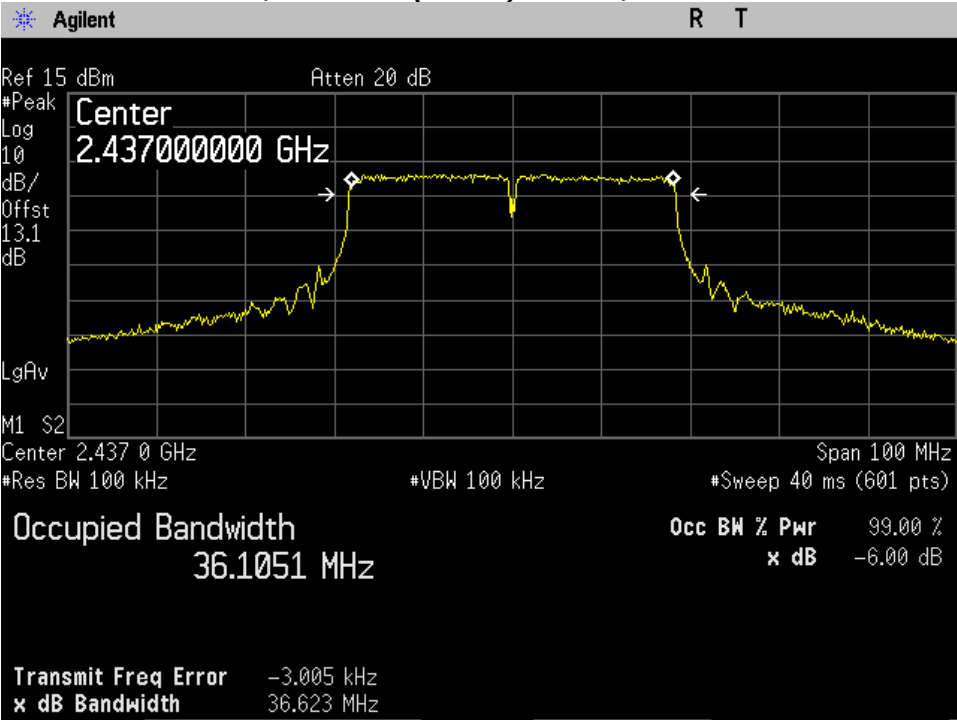

**6 dB Bandwidth, 802.11n(HT40) mode, Highest Channel**

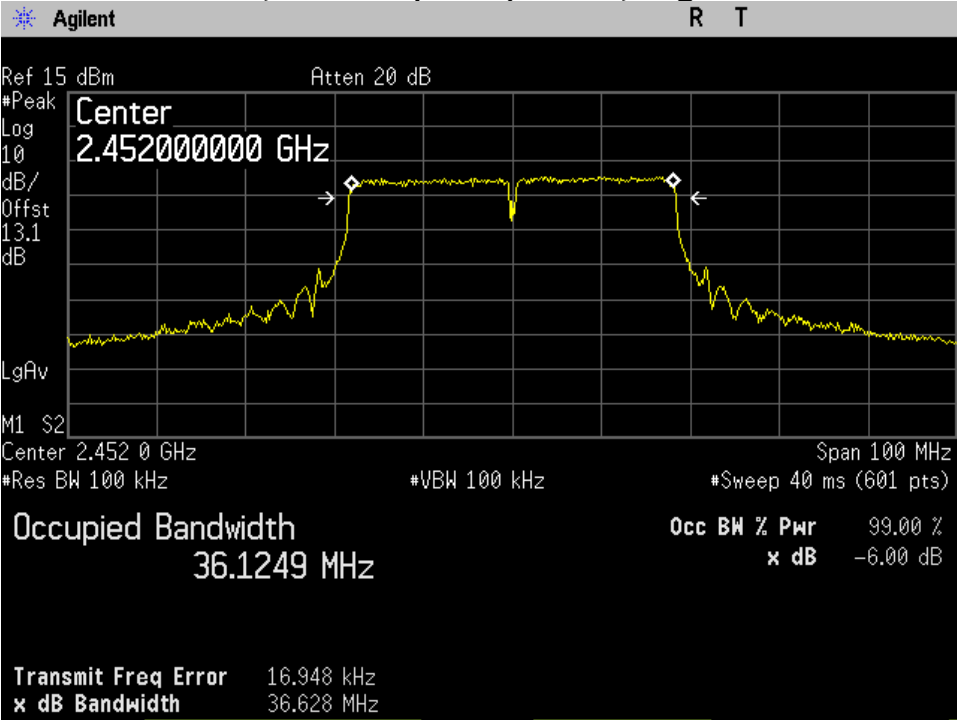

## TEST DATA

---

### 8.4 Peak Power Output

FCC §15.247(b), IC RSS-210 Issue 7 Clause A8.4

Test Mode : Set to Lowest channel, Middle channel and Highest channel

Result:

#### 802.11b mode

Channel	Frequency(MHz)	Peak Power(dBm)	Limit(dBm)
Low	2412	15.91	30
Middle	2437	16.17	30
High	2462	16.23	30

#### 802.11g mode

Channel	Frequency(MHz)	Peak Power(dBm)	Limit(dBm)
Low	2412	14.35	30
Middle	2437	14.98	30
High	2462	15.67	30

**TEST DATA**

---

**802.11n (HT20) mode**

Channel	Frequency(MHz)	Peak Power(dBm)	Limit(dBm)
Low	2412	14.62	30
Middle	2437	14.64	30
High	2462	14.44	30

**802.11n (HT40) mode**

Channel	Frequency(MHz)	Peak Power(dBm)	Limit(dBm)
Low	2422	12.37	30
Middle	2437	13.39	30
High	2452	11.46	30

## TEST DATA

---

### 8.5 Power Spectral Density

FCC §15.247(e), IC RSS-210 Issue 7 Clause A8.2

Test Mode : Set to Lowest channel, Middle channel and Highest channel

Result:

#### **802.11b mode**

Channel	Frequency(MHz)	PPSD(dBm)	Limit(dBm)
Low	2412	-8.90	8
Middle	2437	-9.27	8
High	2462	-8.89	8

#### **802.11g mode**

Channel	Frequency(MHz)	PPSD(dBm)	Limit(dBm)
Low	2412	-17.56	8
Middle	2437	-17.09	8
High	2462	-17.15	8

## TEST DATA

---

### 802.11n(HT20) mode

Channel	Frequency(MHz)	PPSD(dBm)	Limit(dBm)
Low	2412	-18.60	8
Middle	2437	-18.31	8
High	2462	-18.77	8

### 802.11n(HT40) mode

Channel	Frequency(MHz)	PPSD(dBm)	Limit(dBm)
Low	2422	-19.73	8
Middle	2437	-19.50	8
High	2452	-20.16	8

**PLOTS OF EMISSIONS**

**802.11b mode**

**Power Spectral Density, 802.11b mode, Lowest Channel**

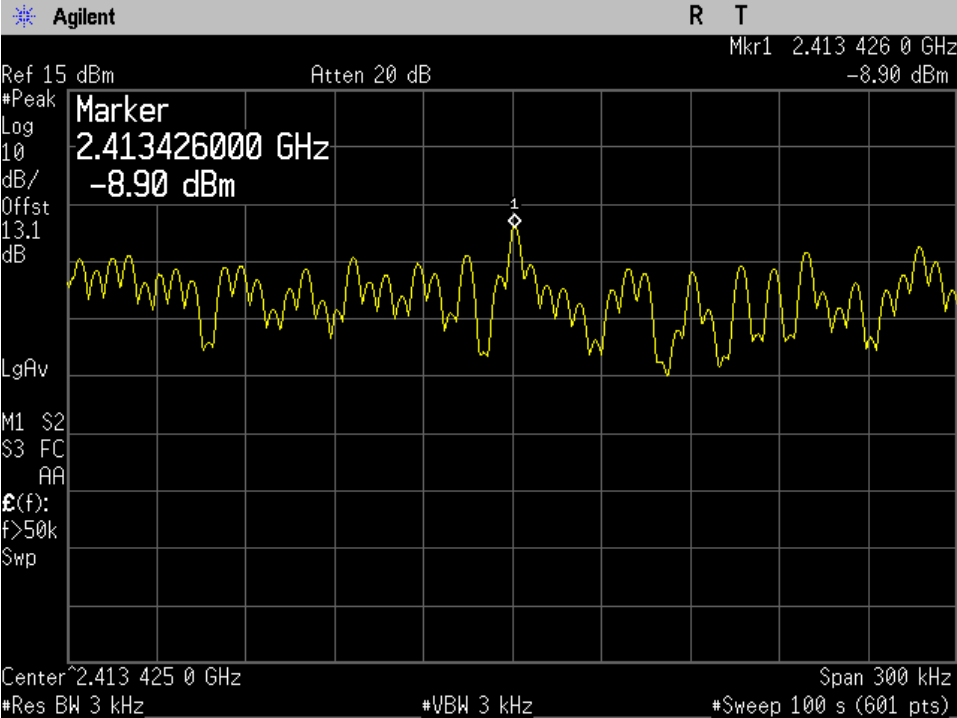

**Power Spectral Density, 802.11b mode, Middle Channel**

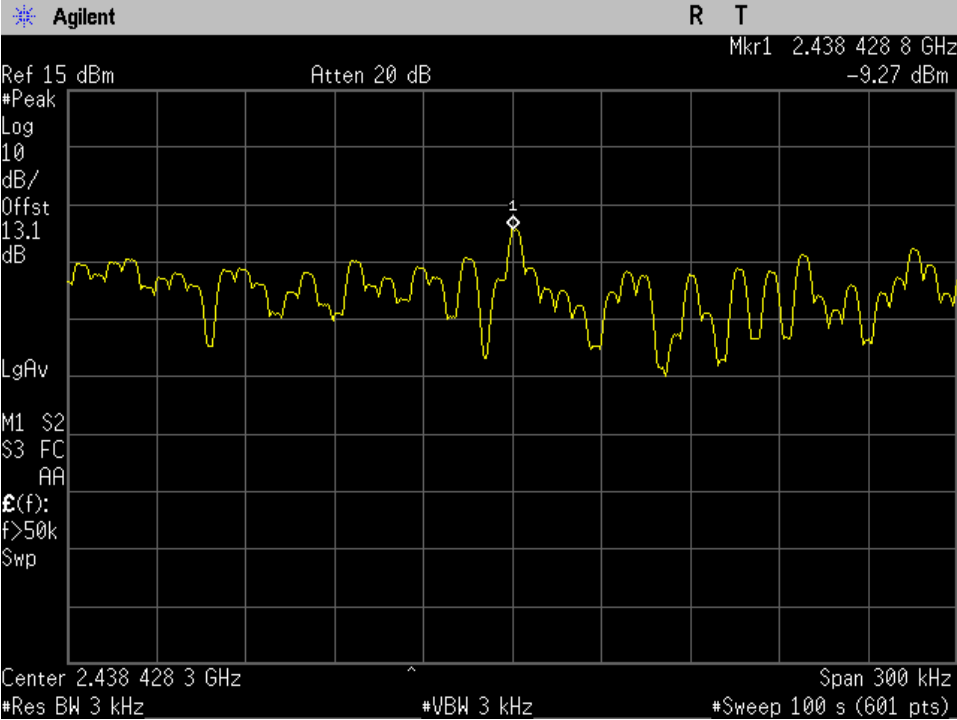

**PLOTS OF EMISSIONS**

**Power Spectral Density, 802.11b mode, Highest Channel**

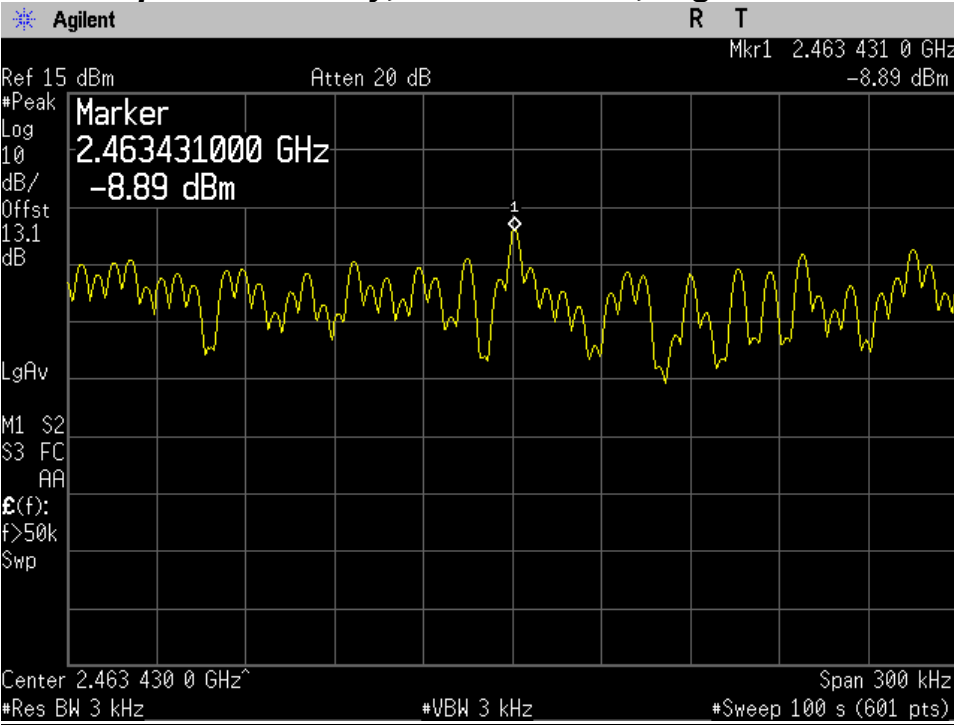

**802.11g mode**

**Power Spectral Density, 802.11g mode, Lowest Channel**

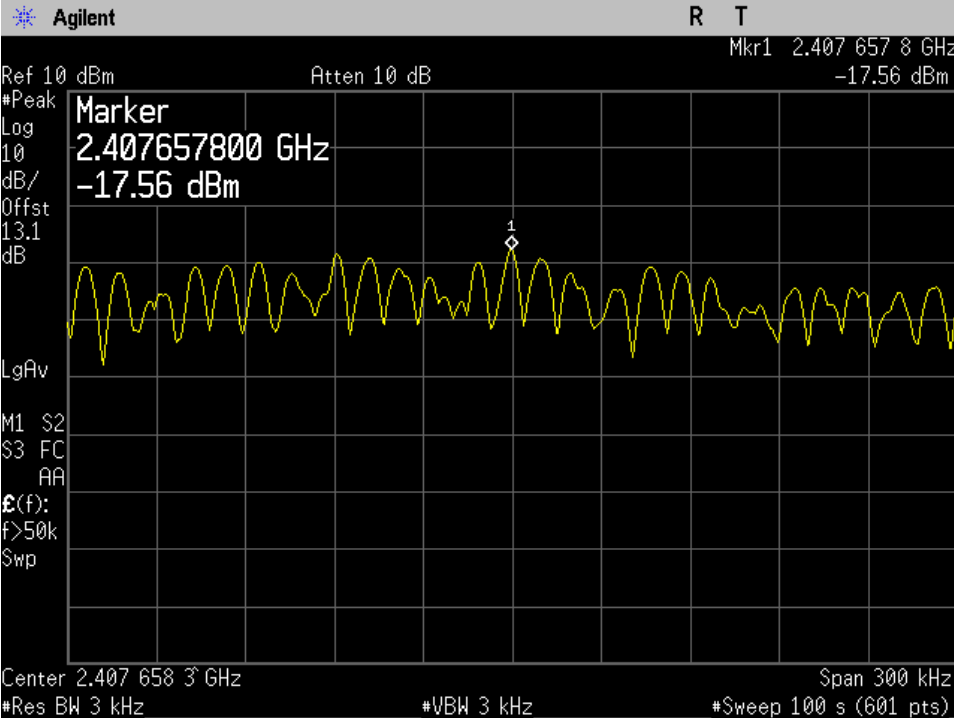

# PLOTS OF EMISSIONS

## Power Spectral Density, 802.11g mode, Middle Channel

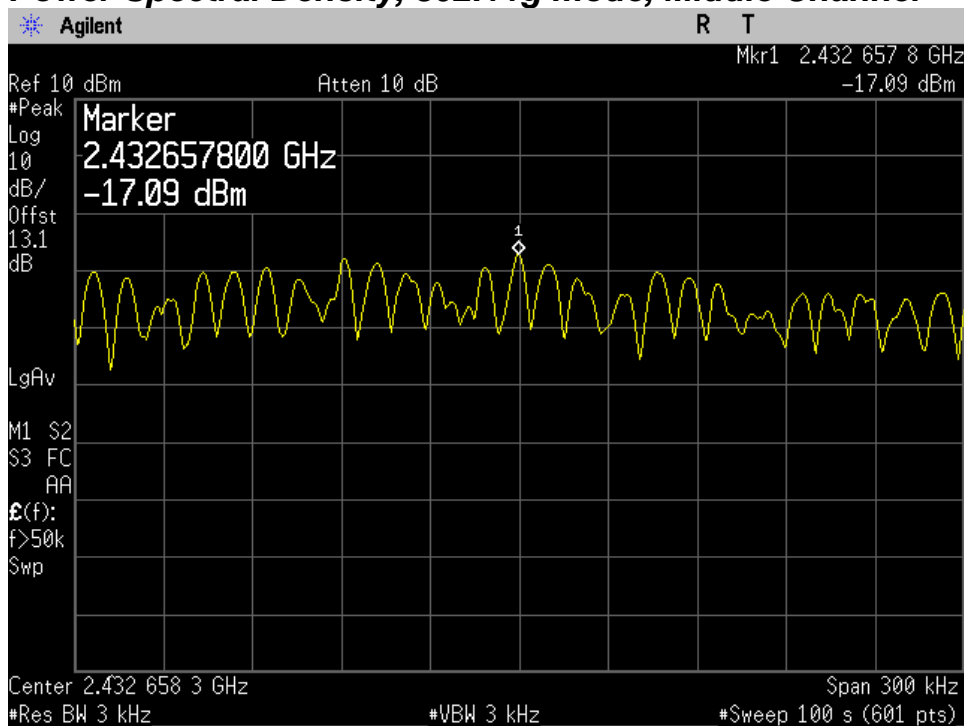

## Power Spectral Density, 802.11g mode, Highest Channel

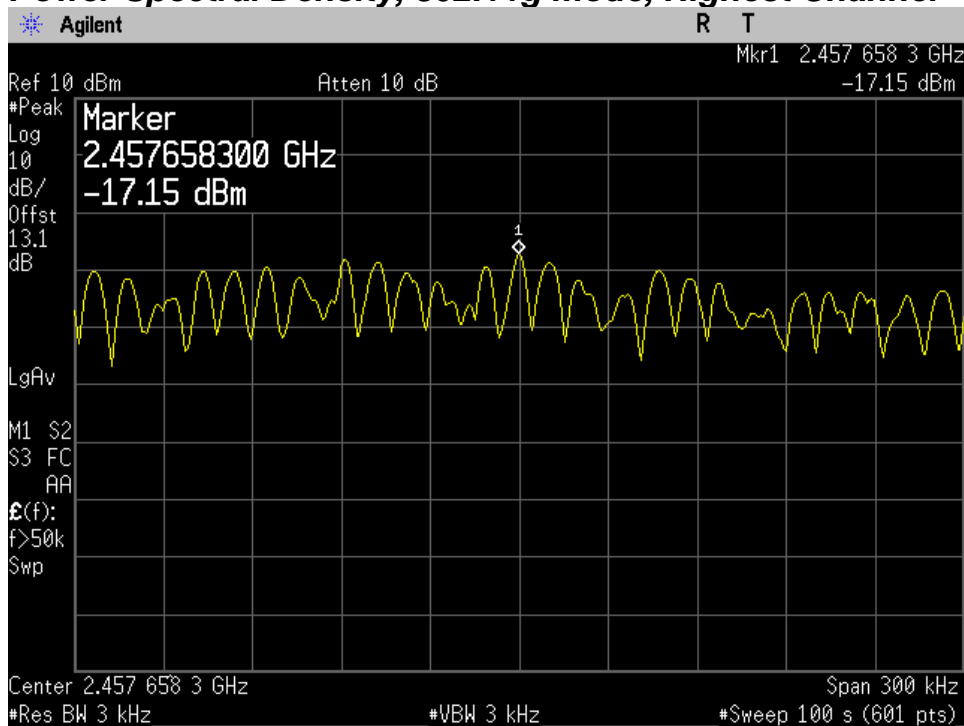

# PLOTS OF EMISSIONS

## 802.11n(HT20) mode

### **Power Spectral Density, 802.11n(HT20)mode, Lowest Channel**

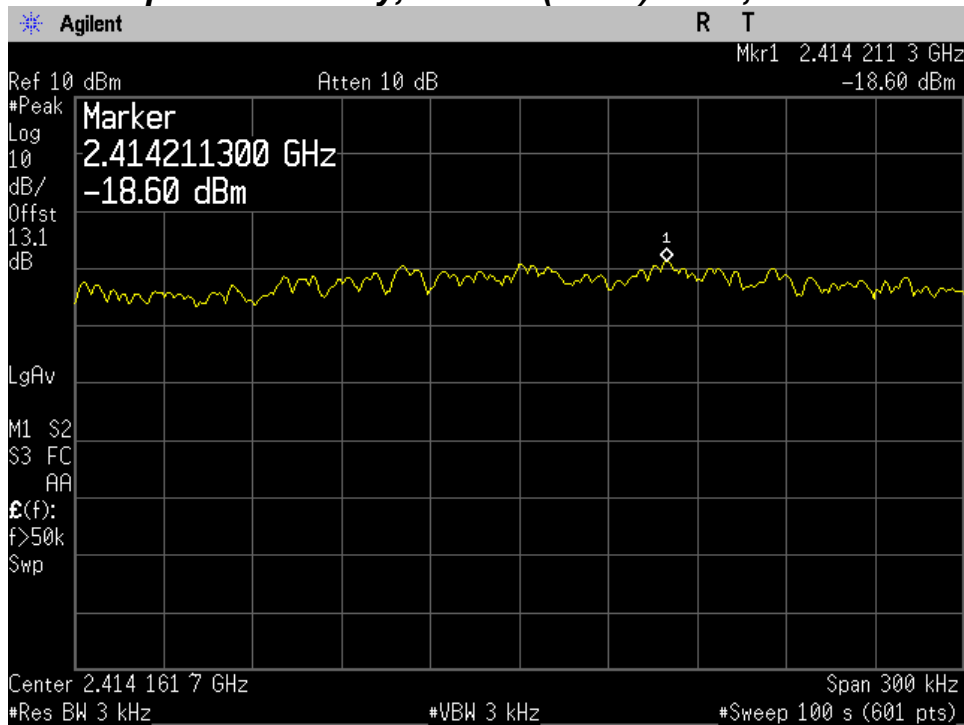

### **Power Spectral Density, 802.11n(HT20)mode, Middle Channel**

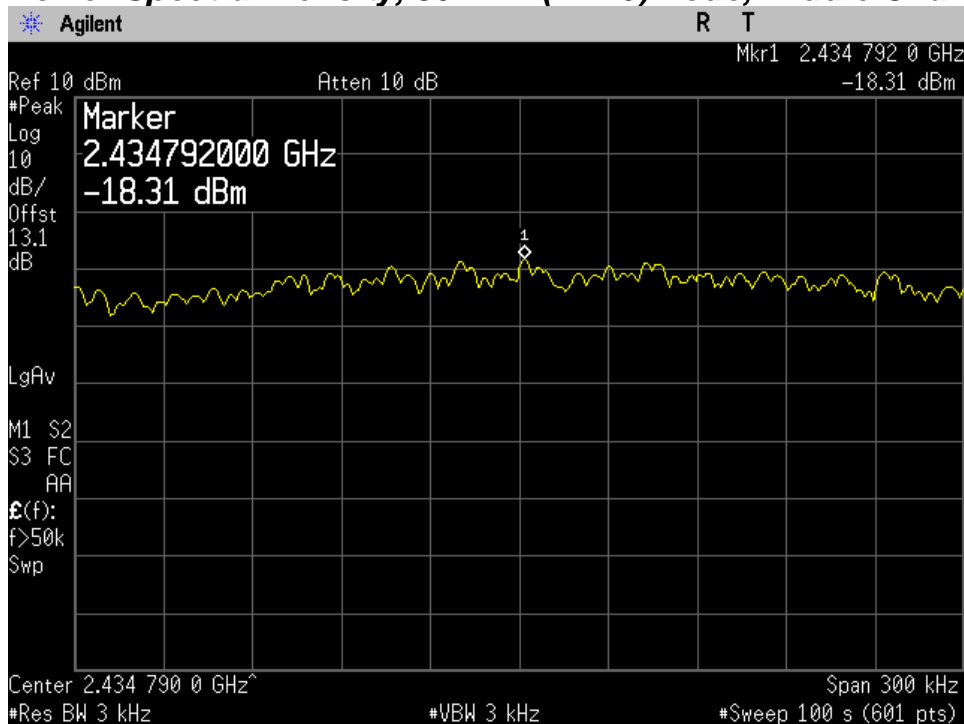

# PLOTS OF EMISSIONS

## Power Spectral Density, 802.11n(HT20)mode, Highest Channel

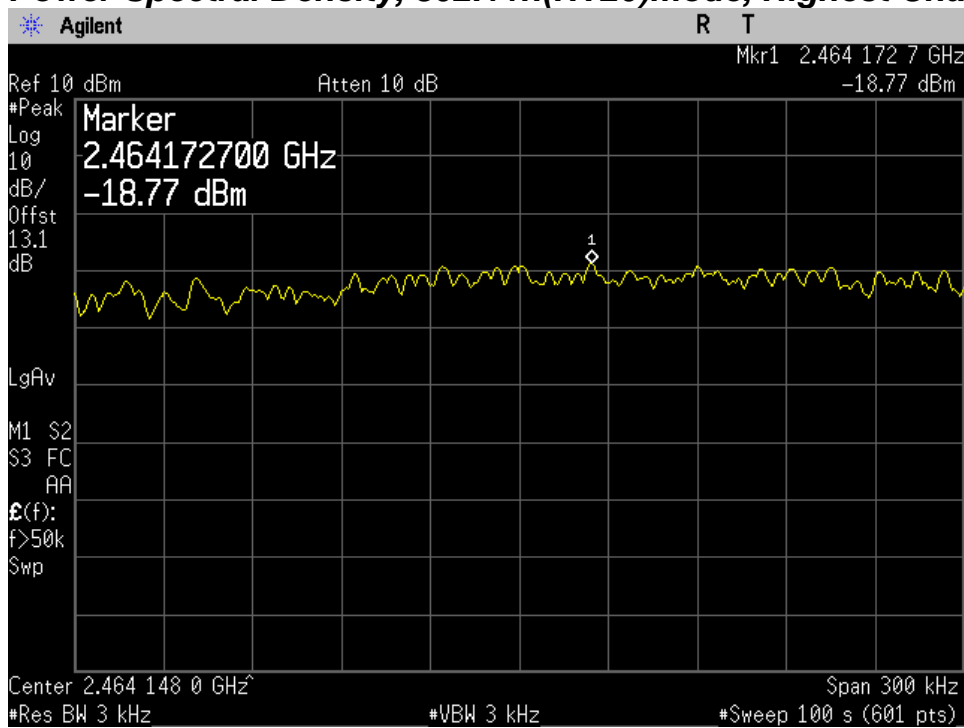

## 802.11n(HT40) mode

## Power Spectral Density, 802.11n(HT40)mode, Lowest Channel

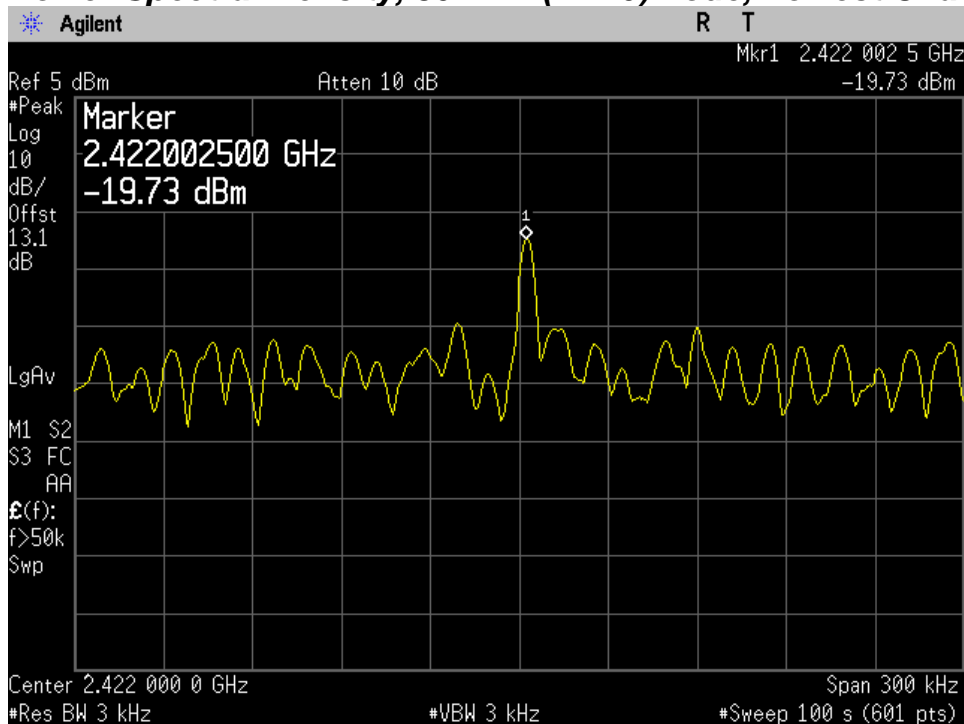

**PLOTS OF EMISSIONS**

**Power Spectral Density, 802.11n(HT40)mode, Middle Channel**

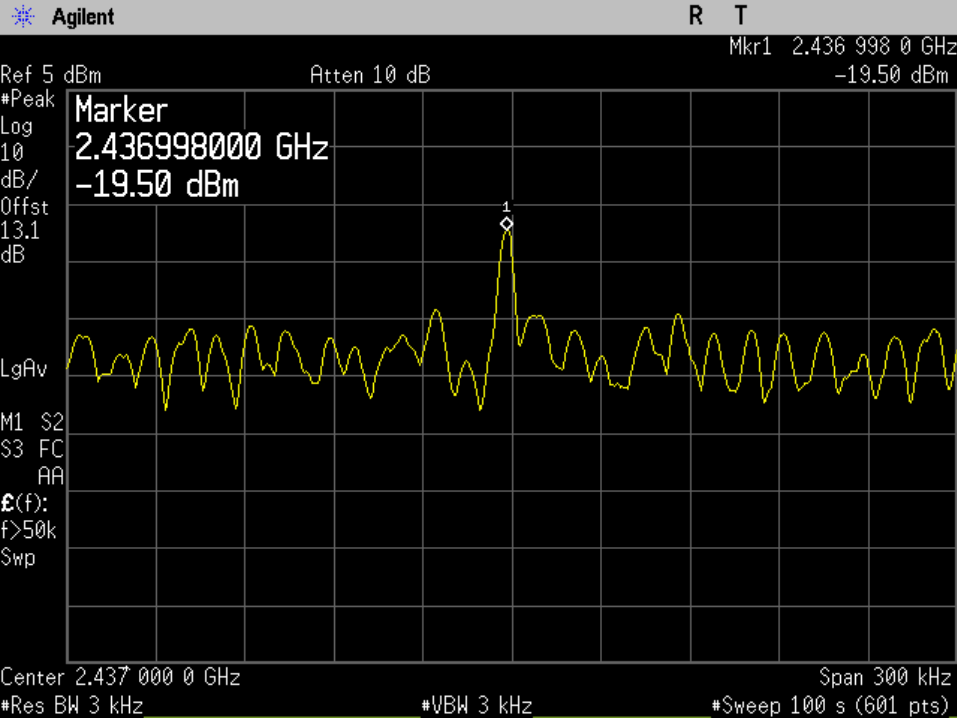

**Power Spectral Density, 802.11n(HT40)mode, Highest Channel**

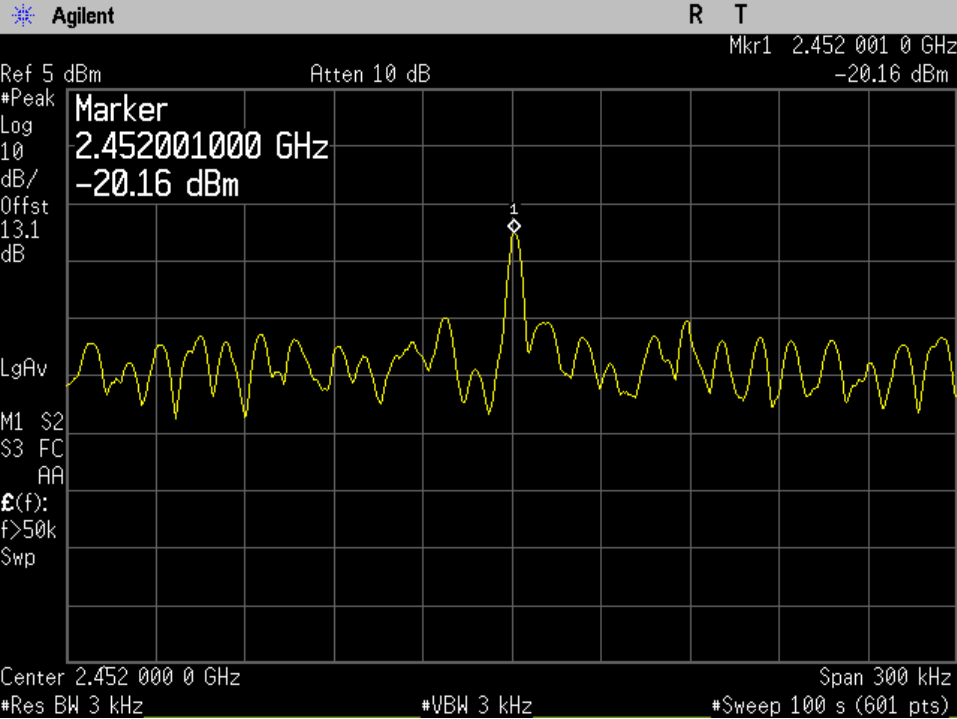

## TEST DATA

---

### 8.6 Conducted Spurious Emissions

FCC §15.247(d), IC RSS-210 A8.5

Test Mode : Set to Lowest channel, Middle channel and Highest channel

Result:

#### 802.11b/g/n(HT20) mode

Channel	Frequency(MHz)	Result(dBc)	Limit(dBc)
Low	2412	More than 20 dBc	20
Middle	2437	More than 20 dBc	20
High	2462	More than 20 dBc	20

#### 802.11n(HT40) mode

Channel	Frequency(MHz)	Result(dBc)	Limit(dBc)
Low	2422	More than 20 dBc	20
Middle	2437	More than 20 dBc	20
High	2452	More than 20 dBc	20

# PLOT OF TEST DATA

**802.11b mode**  
**Conducted Spurious Emissions, 802.11b mode,**  
**30 MHz ~ 10 GHz, Lowest Channel**

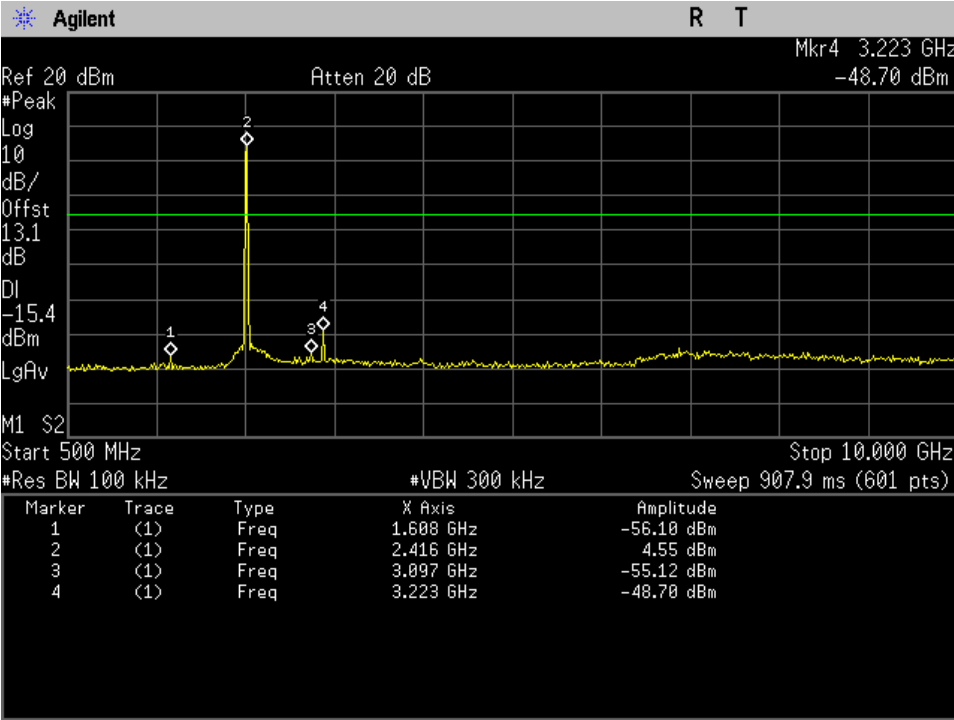

**Conducted Spurious Emissions, 802.11b mode,**  
**10 GHz ~ 25 GHz, Lowest Channel**

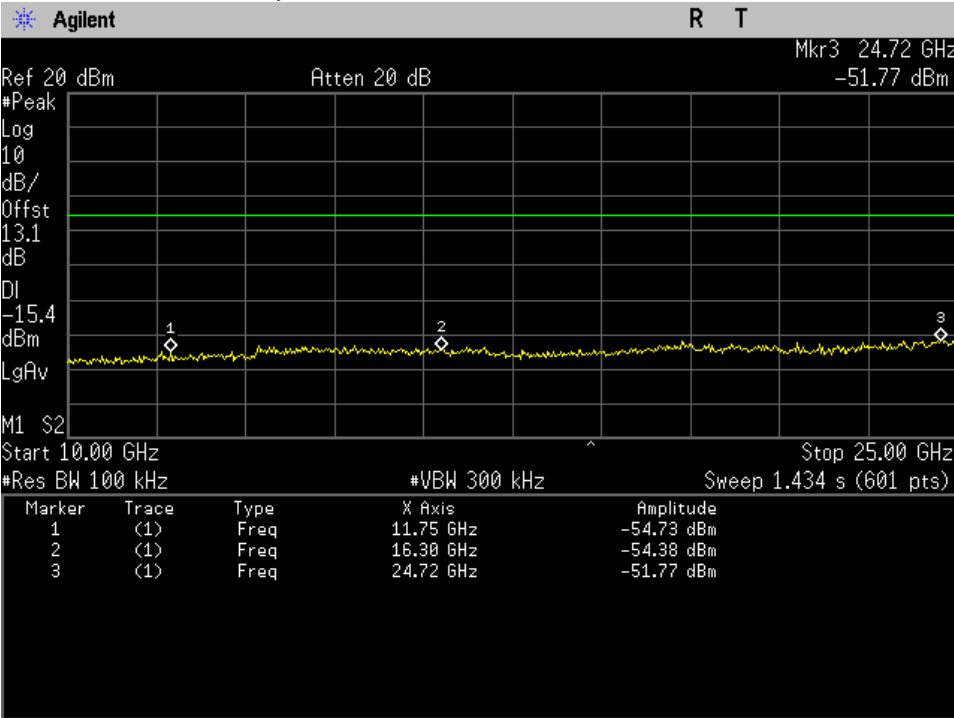

# PLOT OF TEST DATA

## Conducted Spurious Emissions, 802.11b mode, 30 MHz ~ 10 GHz, Middle Channel

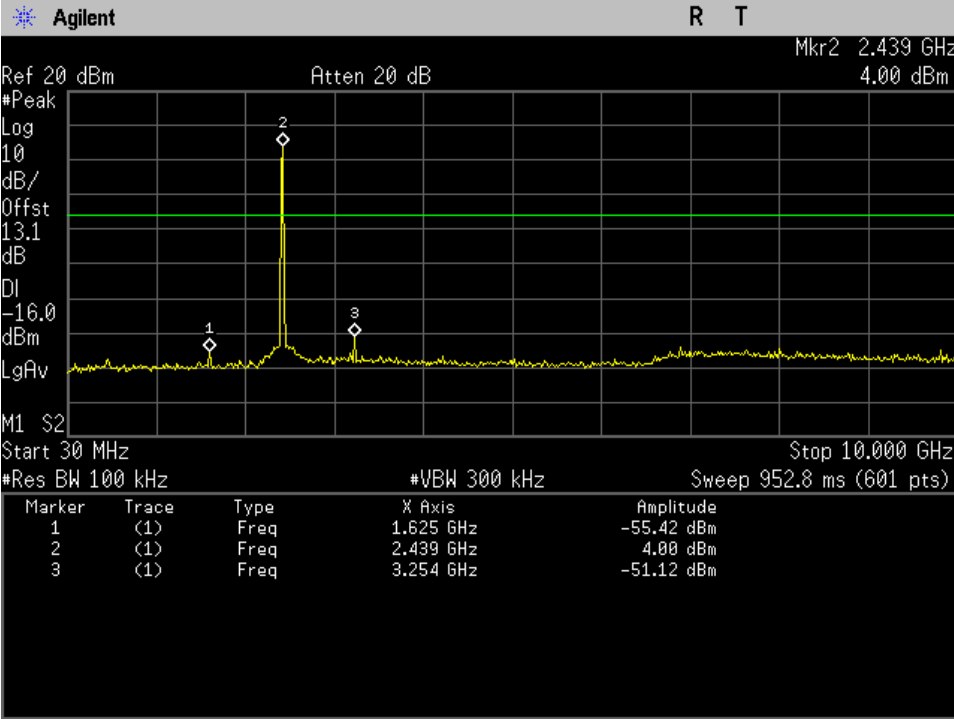

## Conducted Spurious Emissions, 802.11b mode, 10 GHz ~ 25 GHz, Middle Channel

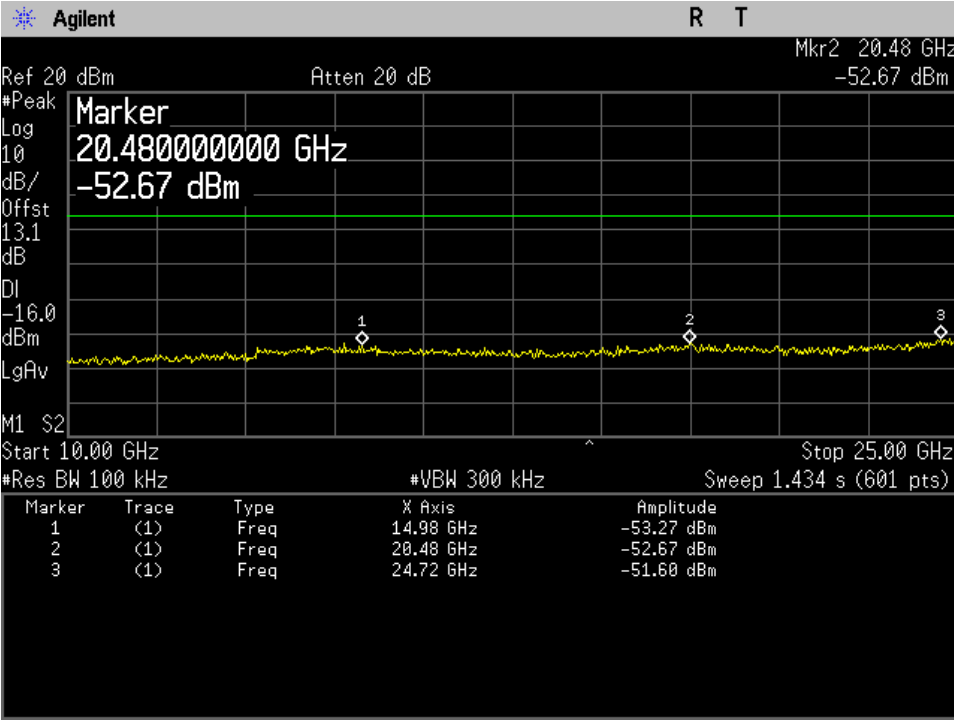

**PLOT OF TEST DATA**

**Conducted Spurious Emissions, 802.11b mode,  
30 MHz ~ 10 GHz, Highest Channel**

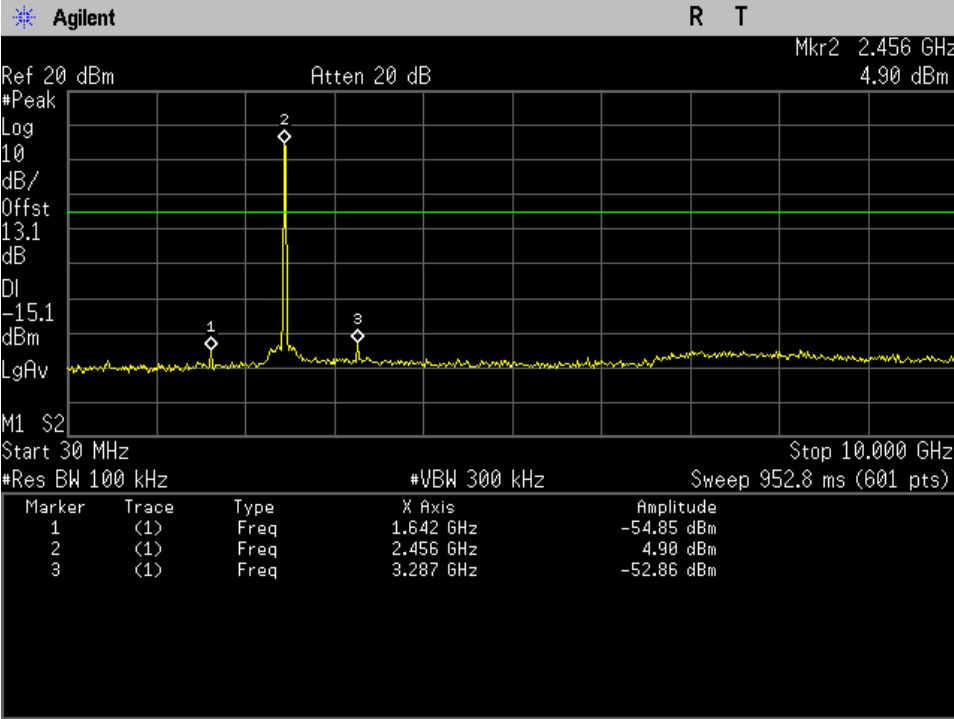

**Conducted Spurious Emissions, 802.11b mode,  
10 GHz ~ 25 GHz, Highest Channel**

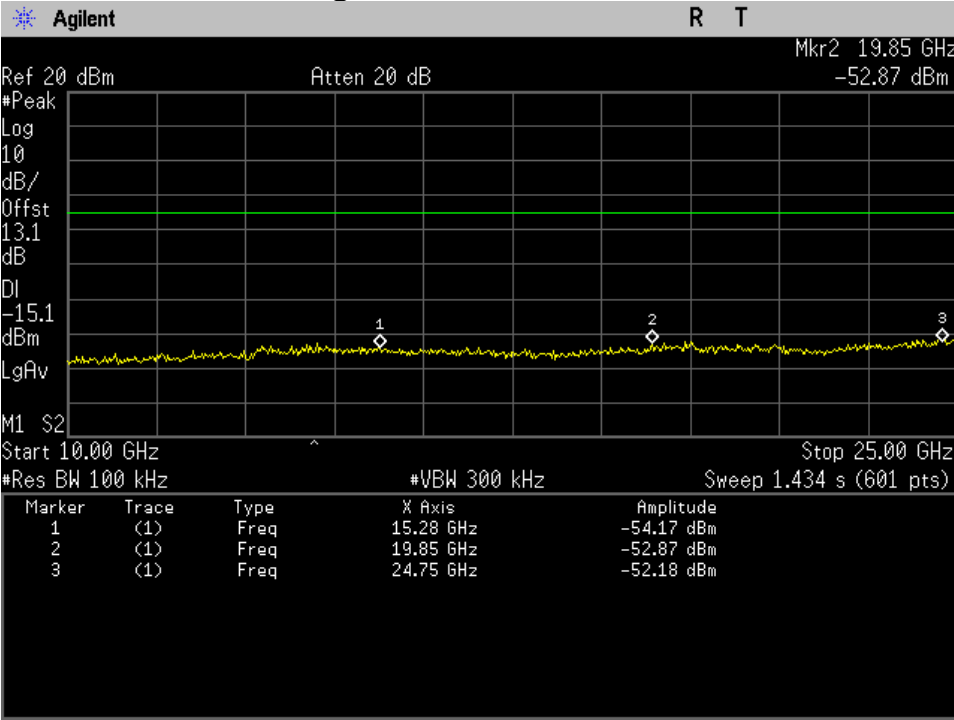

**PLOT OF TEST DATA**

**802.11g mode**  
**Conducted Spurious Emissions, 802.11g mode,**  
**30 MHz ~ 10 GHz, Lowest Channel**

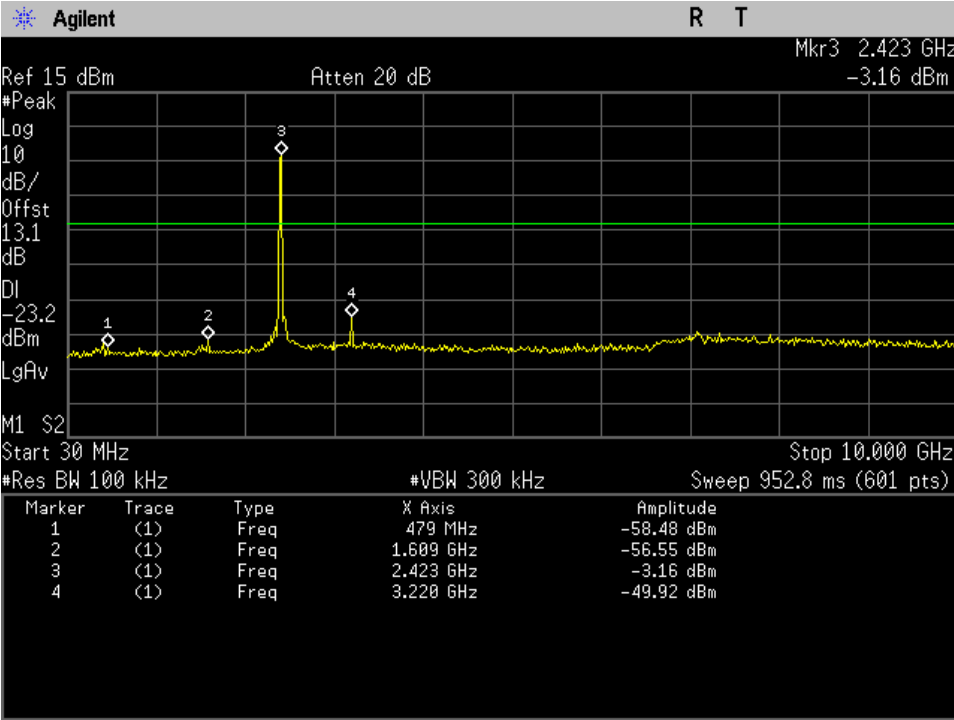

**Conducted Spurious Emissions, 802.11g mode,**  
**10 GHz ~ 25 GHz, Lowest Channel**

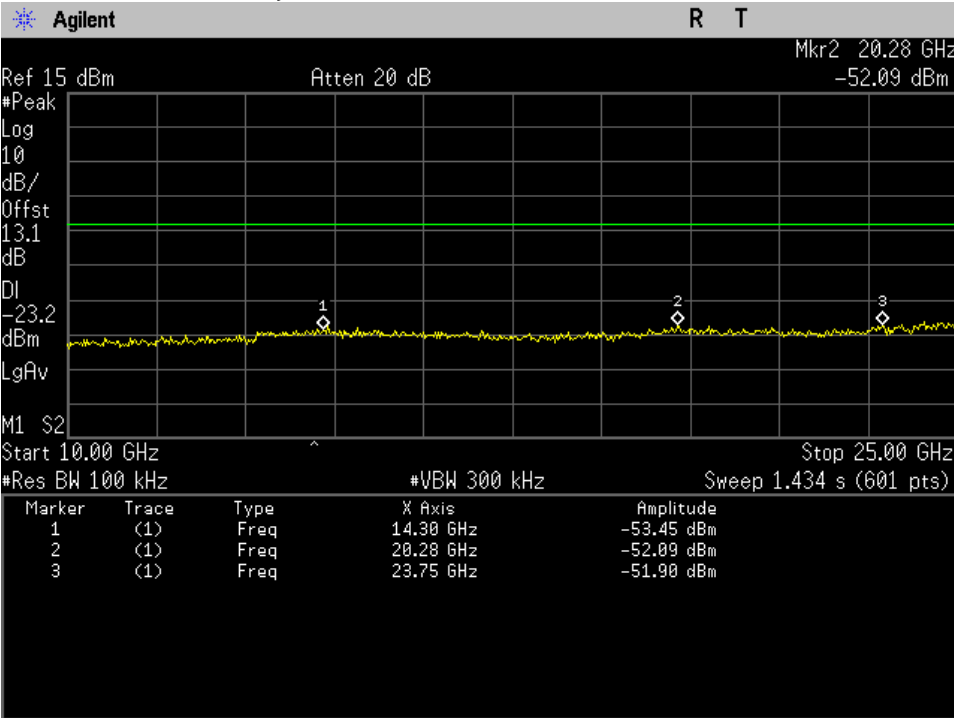

# PLOT OF TEST DATA

## Conducted Spurious Emissions, 802.11g mode, 30 MHz ~ 10 GHz, Middle Channel

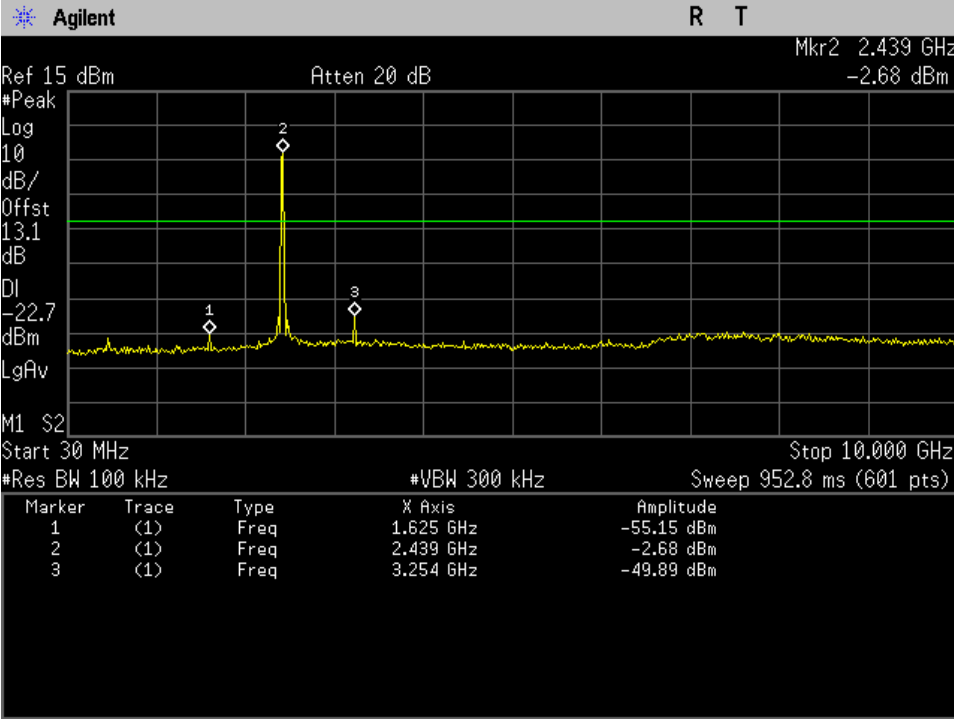

## Conducted Spurious Emissions, 802.11g mode, 10 GHz ~ 25 GHz, Middle Channel

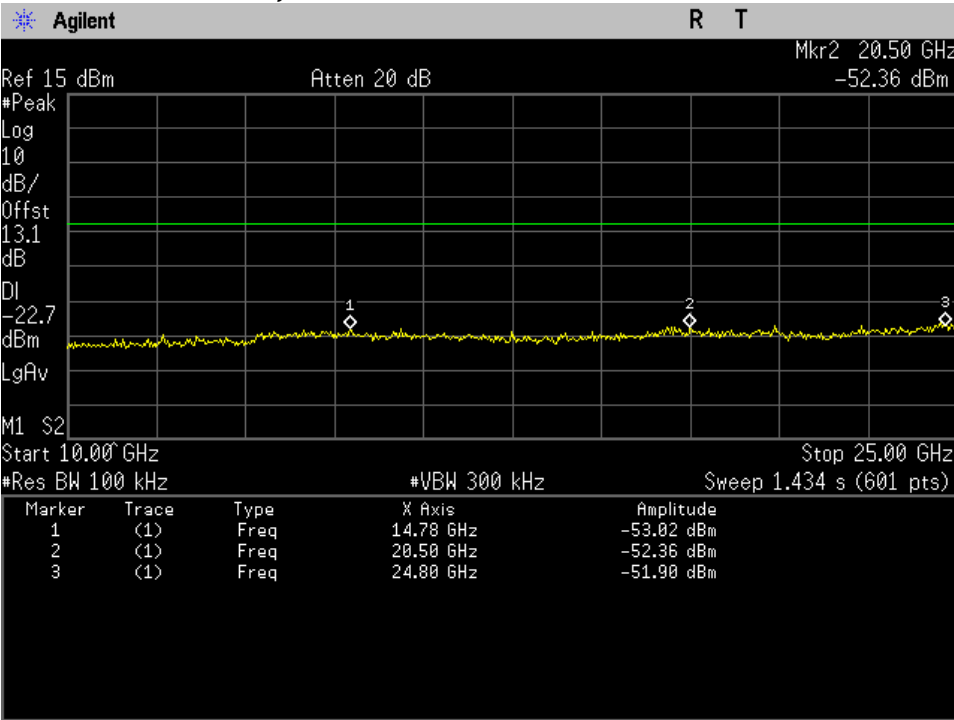

**PLOT OF TEST DATA**

**Conducted Spurious Emissions, 802.11g mode,  
30 MHz ~ 10 GHz, Highest Channel**

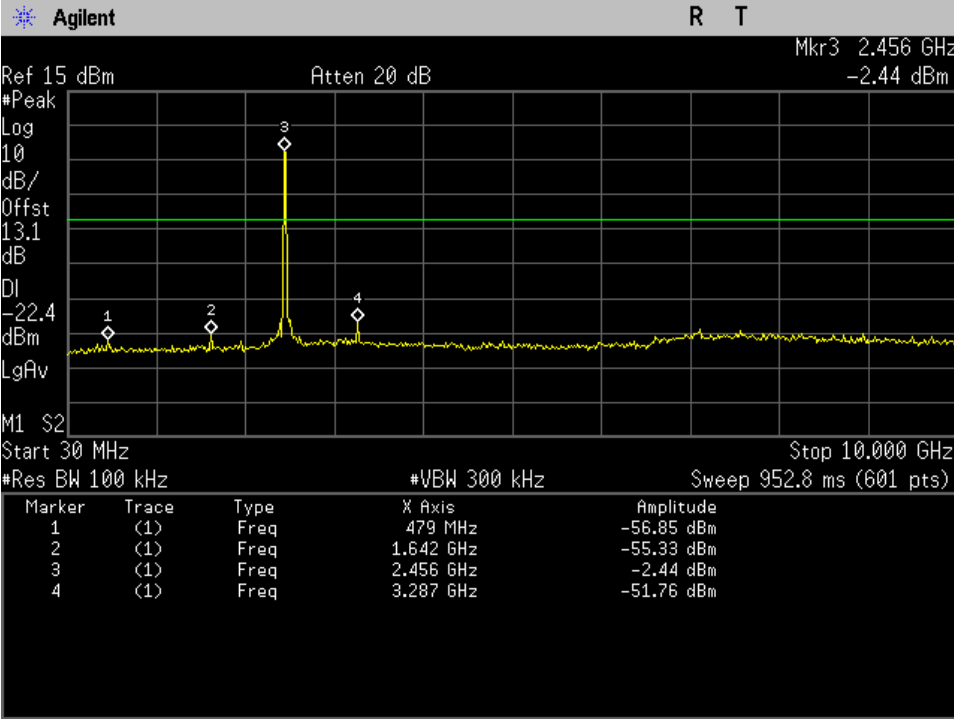

**Conducted Spurious Emissions, 802.11g mode,  
10 GHz ~ 25 GHz, Highest Channel**

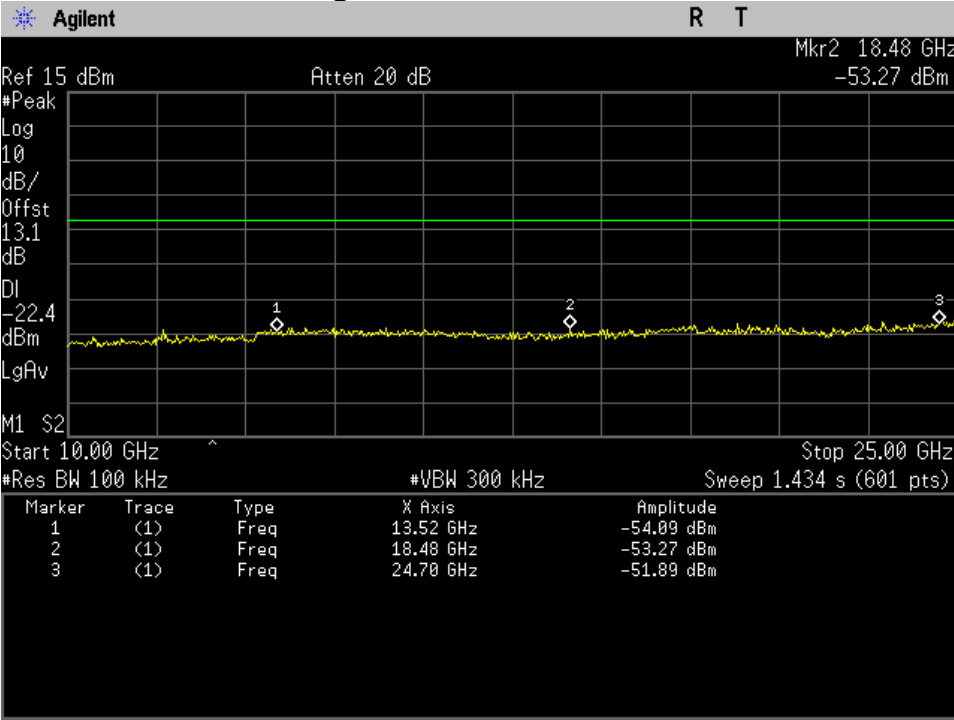

**PLOT OF TEST DATA**

**802.11n(HT20) mode  
Conducted Spurious Emissions, 802.11n(HT20) mode,  
30 MHz ~ 10 GHz, Lowest Channel**

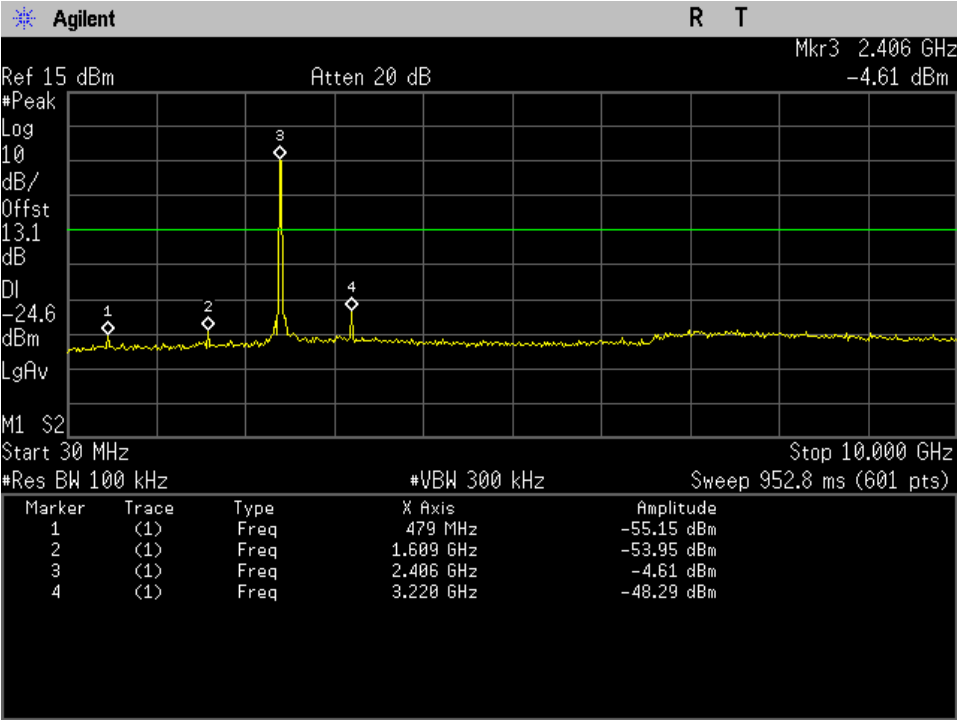

**Conducted Spurious Emissions, 802.11n(HT20) mode,  
10 GHz ~ 25 GHz, Lowest Channel**

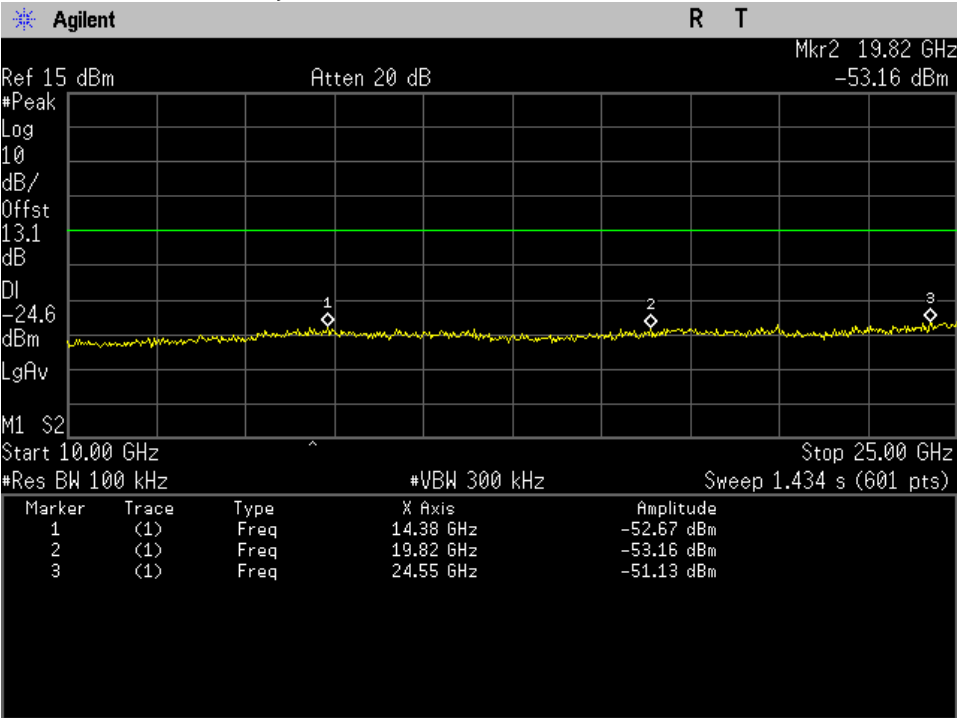

# PLOT OF TEST DATA

## Conducted Spurious Emissions, 802.11n(HT20) mode, 30 MHz ~ 10 GHz, Middle Channel

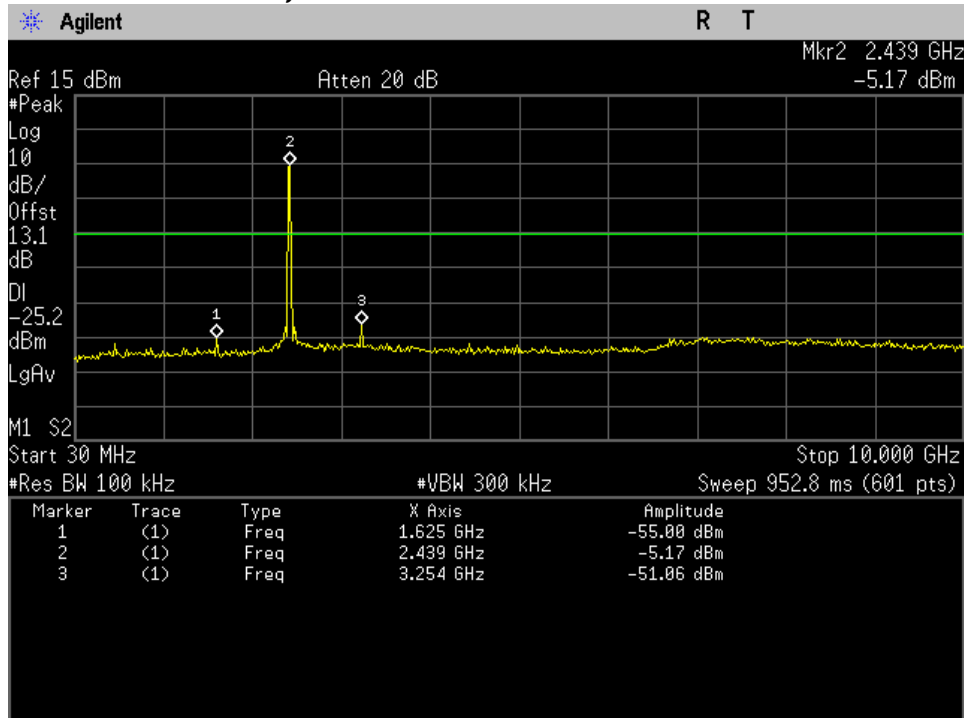

## Conducted Spurious Emissions, 802.11n(HT20) mode, 10 GHz ~ 25 GHz, Middle Channel

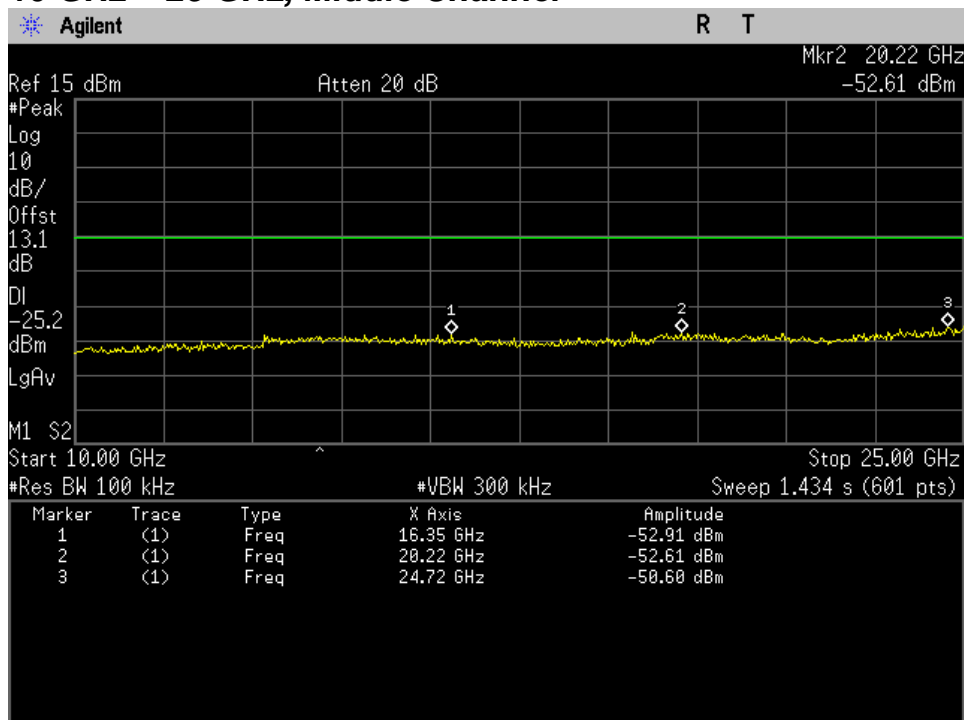

# PLOT OF TEST DATA

## Conducted Spurious Emissions, 802.11n(HT20) mode, 30 MHz ~ 10 GHz, Highest Channel

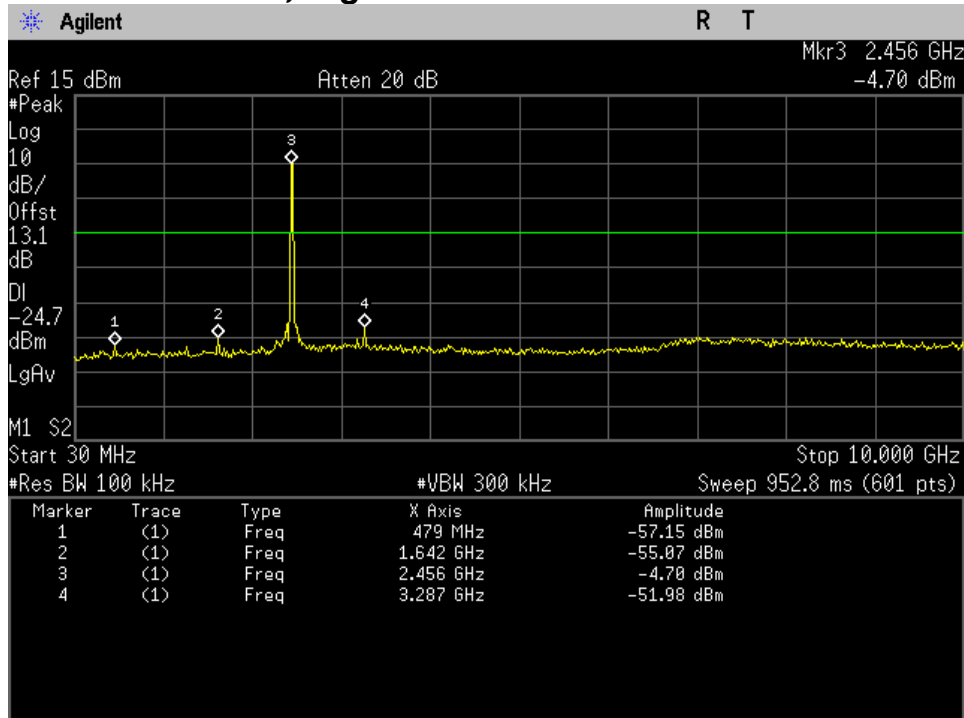

## Conducted Spurious Emissions, 802.11n(HT20) mode, 10 GHz ~ 25 GHz, Highest Channel

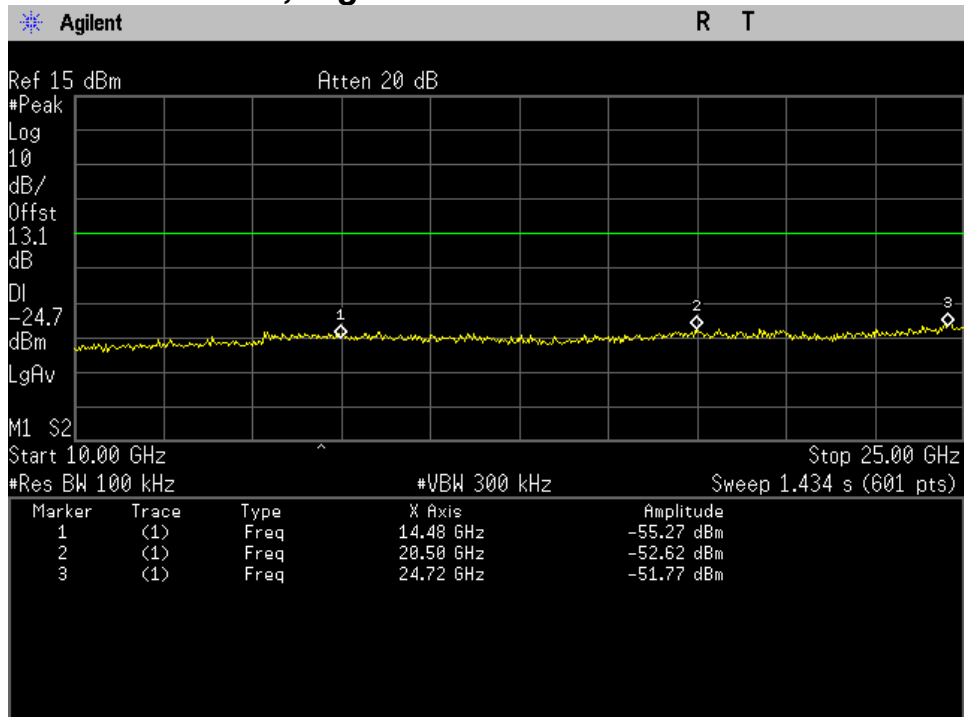

# PLOT OF TEST DATA

## 802.11n(HT40) mode

### Conducted Spurious Emissions, 802.11n(HT40) mode, 30 MHz ~ 10 GHz, Lowest Channel

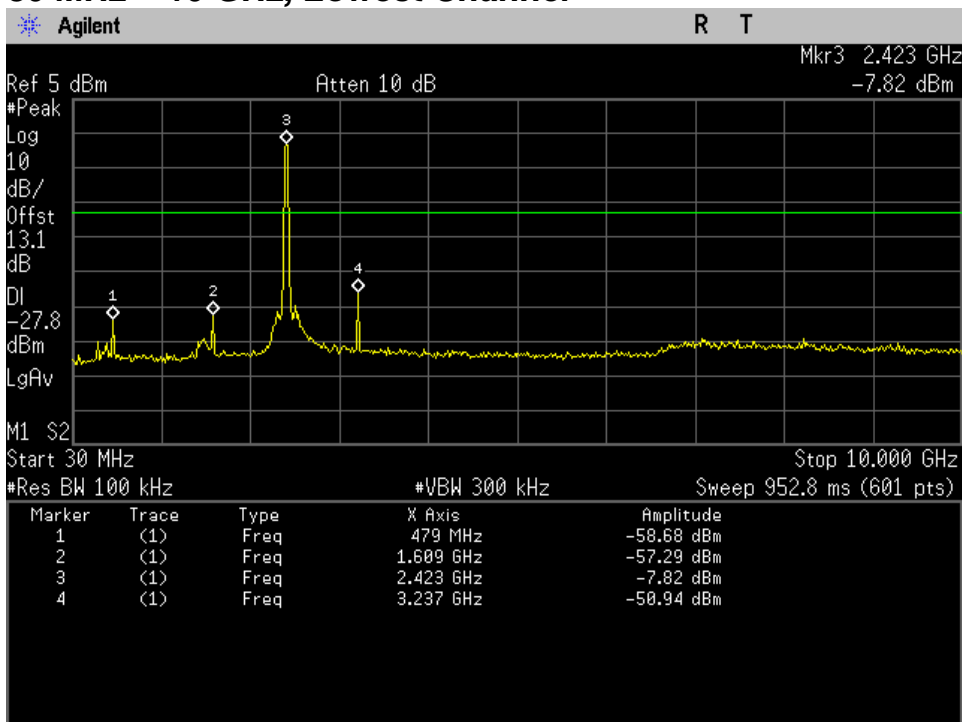

### Conducted Spurious Emissions, 802.11n(HT40) mode, 10 GHz ~ 25 GHz, Lowest Channel

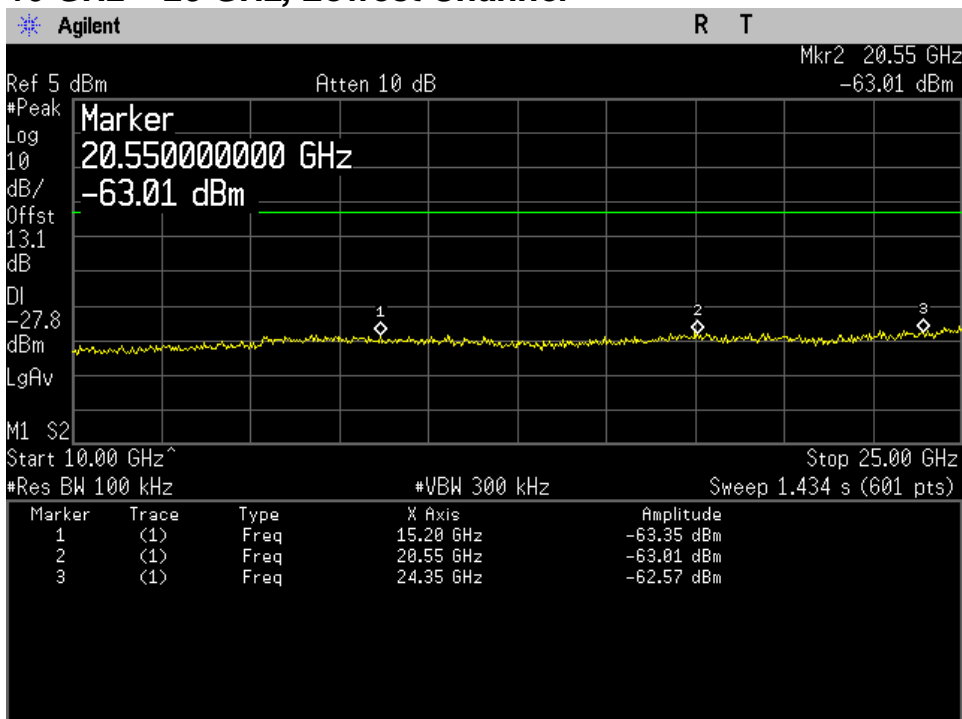

# PLOT OF TEST DATA

## Conducted Spurious Emissions, 802.11n(HT40) mode, 30 MHz ~ 10 GHz, Middle Channel

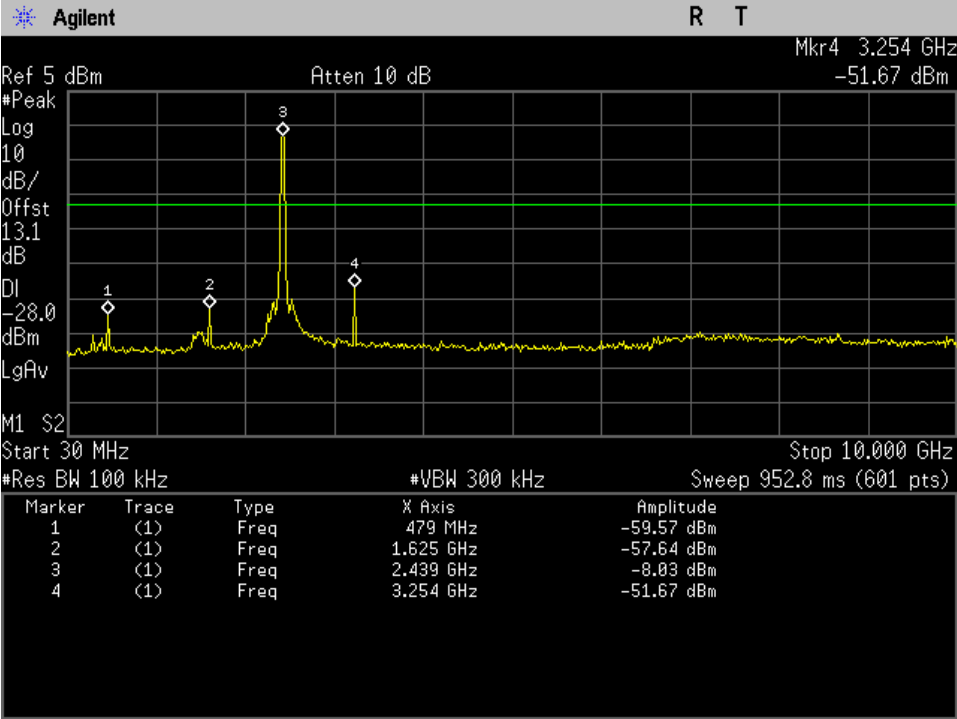

## Conducted Spurious Emissions, 802.11n(HT40) mode, 10 GHz ~ 25 GHz, Middle Channel

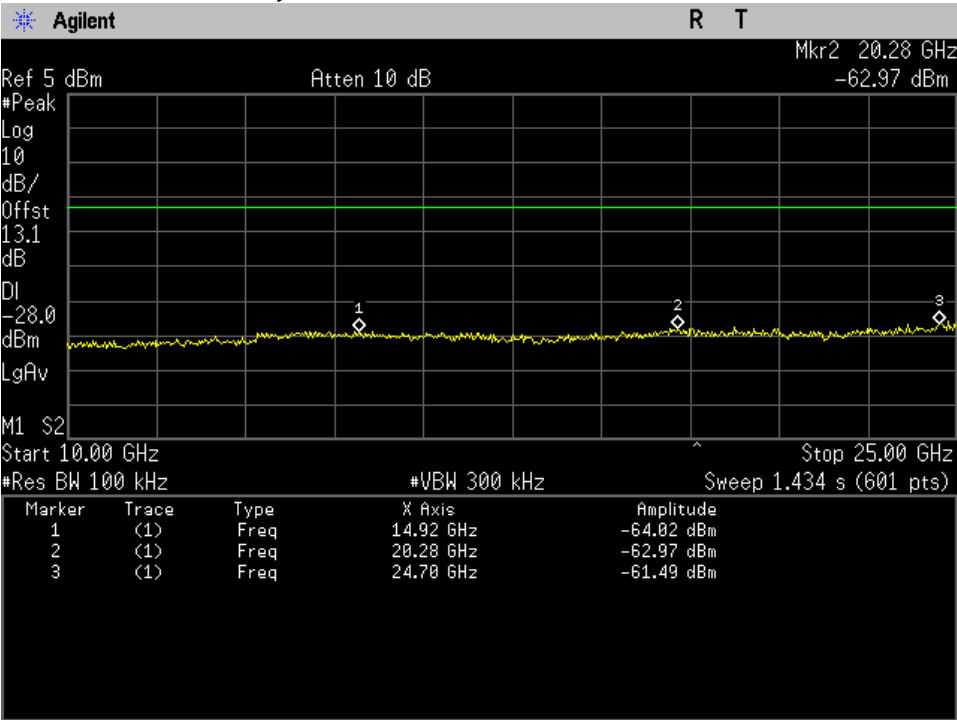

# PLOT OF TEST DATA

## Conducted Spurious Emissions, 802.11n(HT40) mode, 30 MHz ~ 10 GHz, Highest Channel

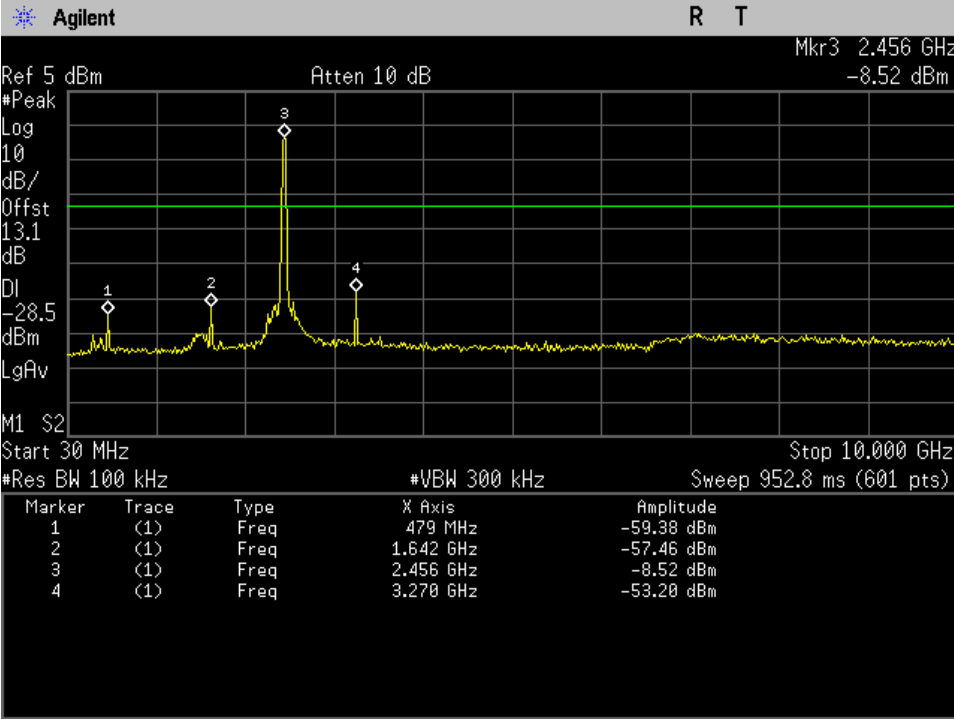

## Conducted Spurious Emissions, 802.11n(HT40) mode, 10 GHz ~ 25 GHz, Highest Channel

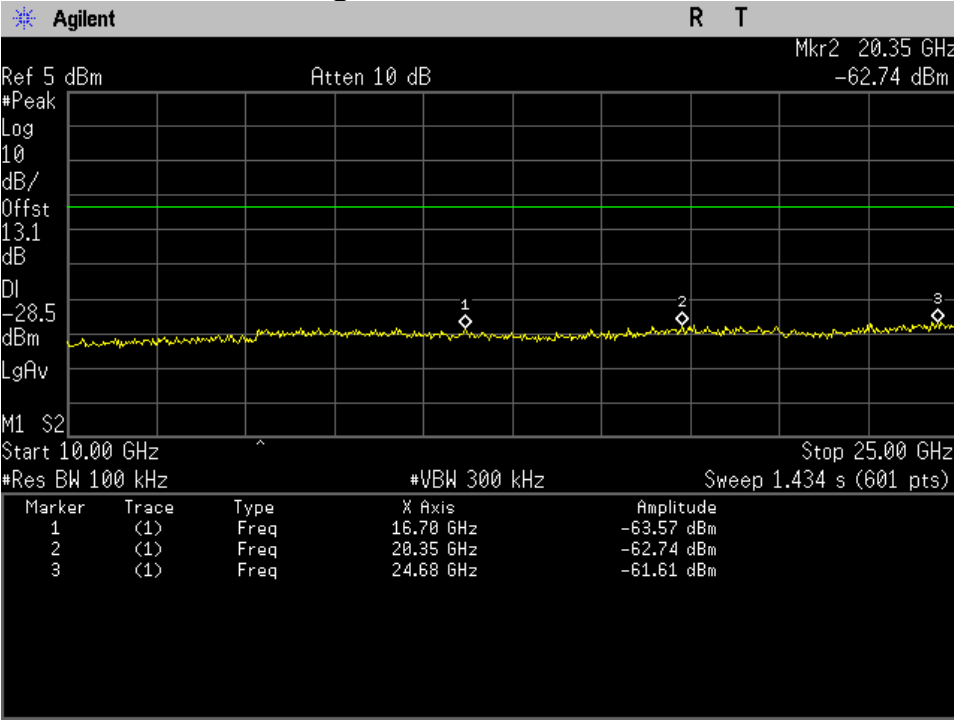

**PLOT OF TEST DATA**

**802.11b mode**

**Band Edge , 802.11b mode, Lowest Channel**

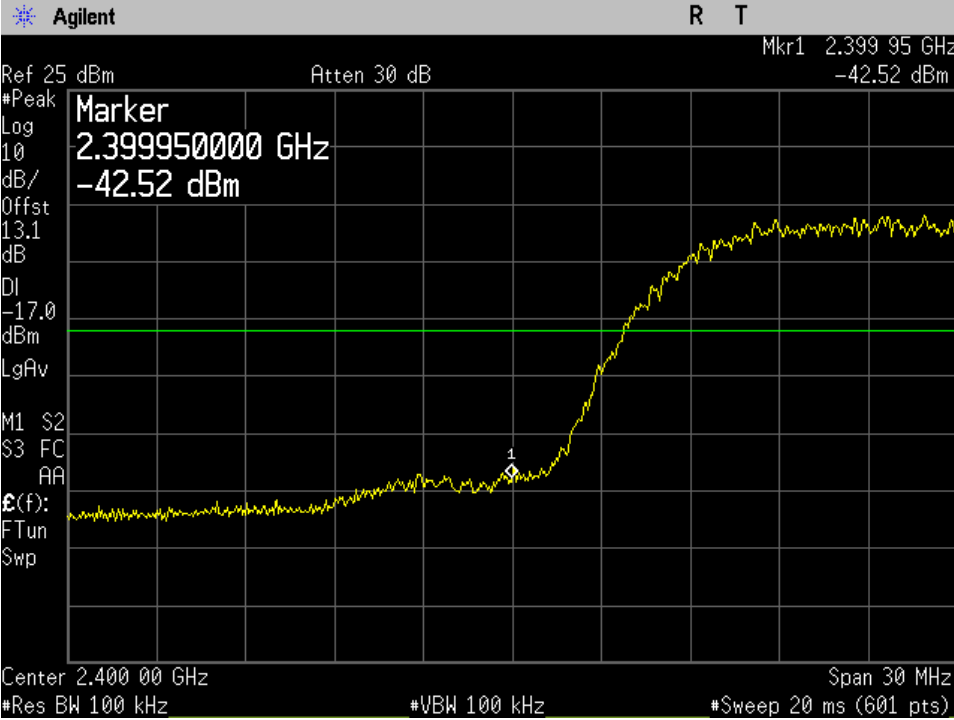

**Band Edge , 802.11b mode Highest Channel**

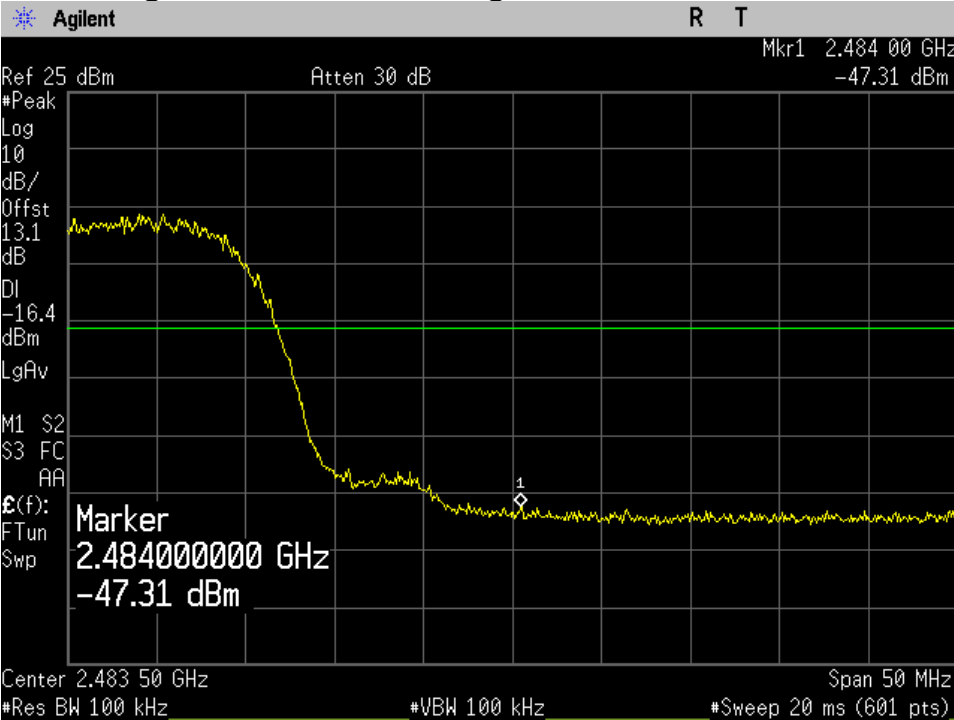

**PLOT OF TEST DATA**

**802.11g mode**

**Band Edge , 802.11g mode, Lowest Channel**

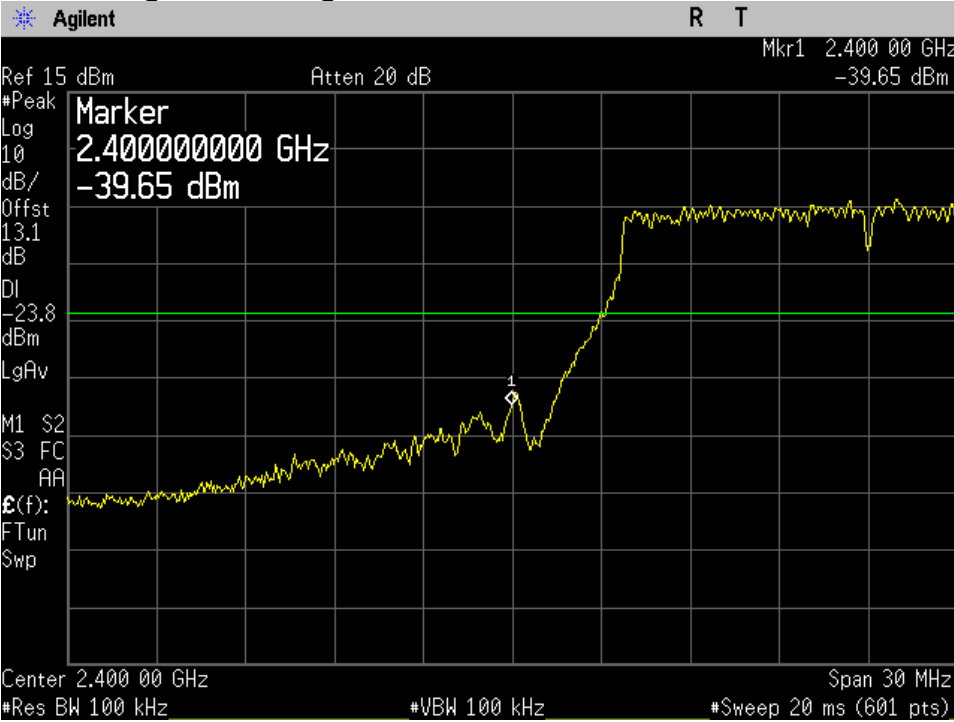

**Band Edge , 802.11g mode Highest Channel**

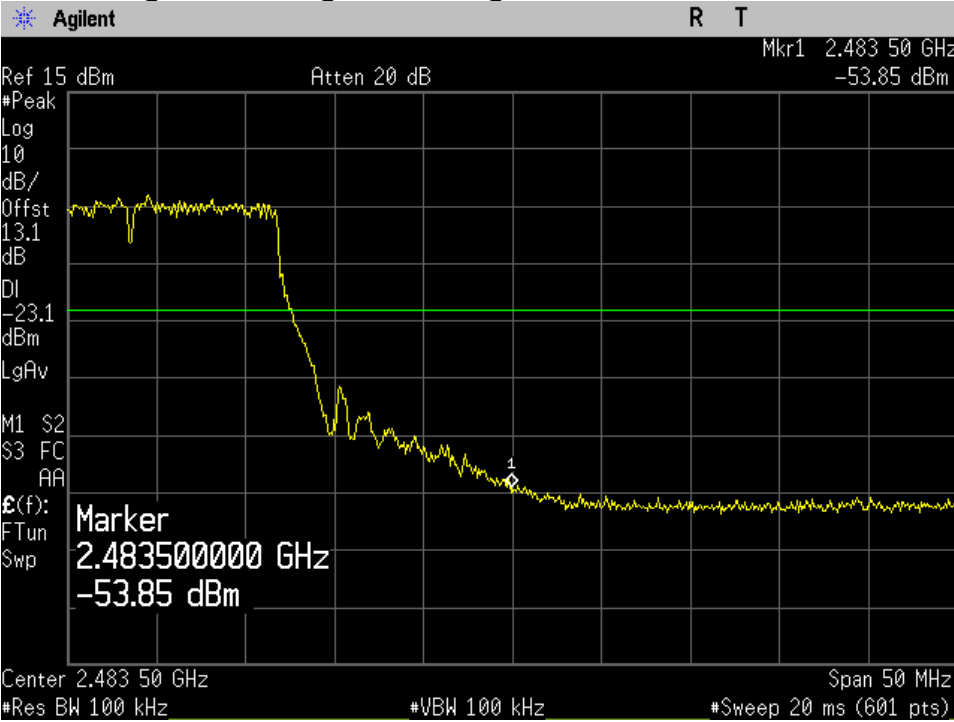

**PLOT OF TEST DATA**

**802.11n(HT20) mode**

**Band Edge , 802.11n(HT20) mode, Lowest Channel**

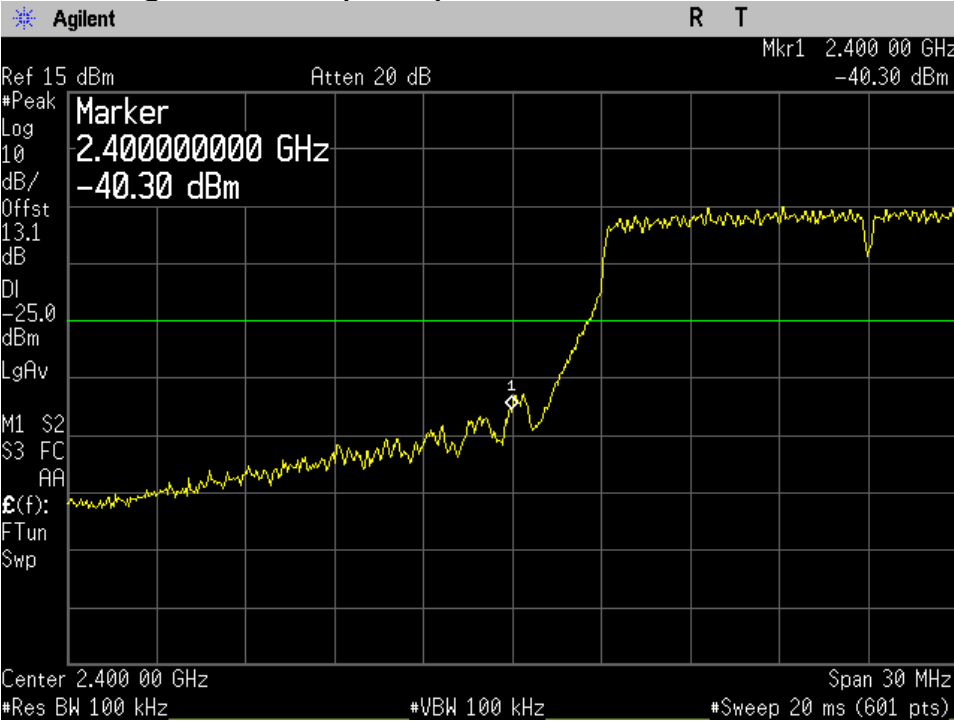

**Band Edge , 802.11n(HT20) mode, Highest Channel**

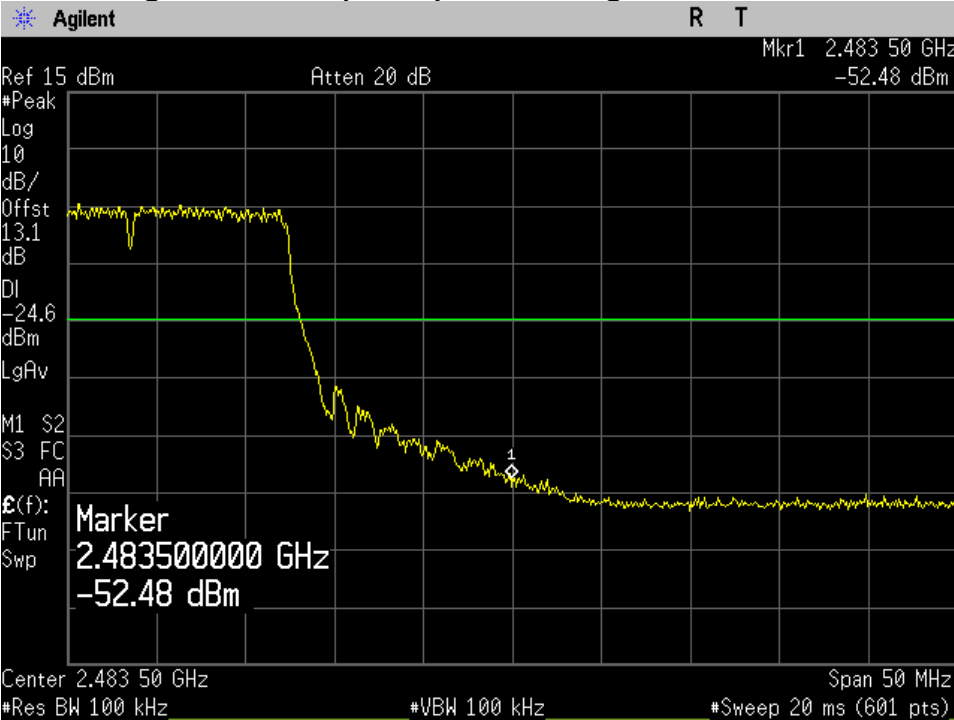

**PLOT OF TEST DATA**

**802.11n(HT40) mode**

**Band Edge , 802.11n(HT40) mode, Lowest Channel**

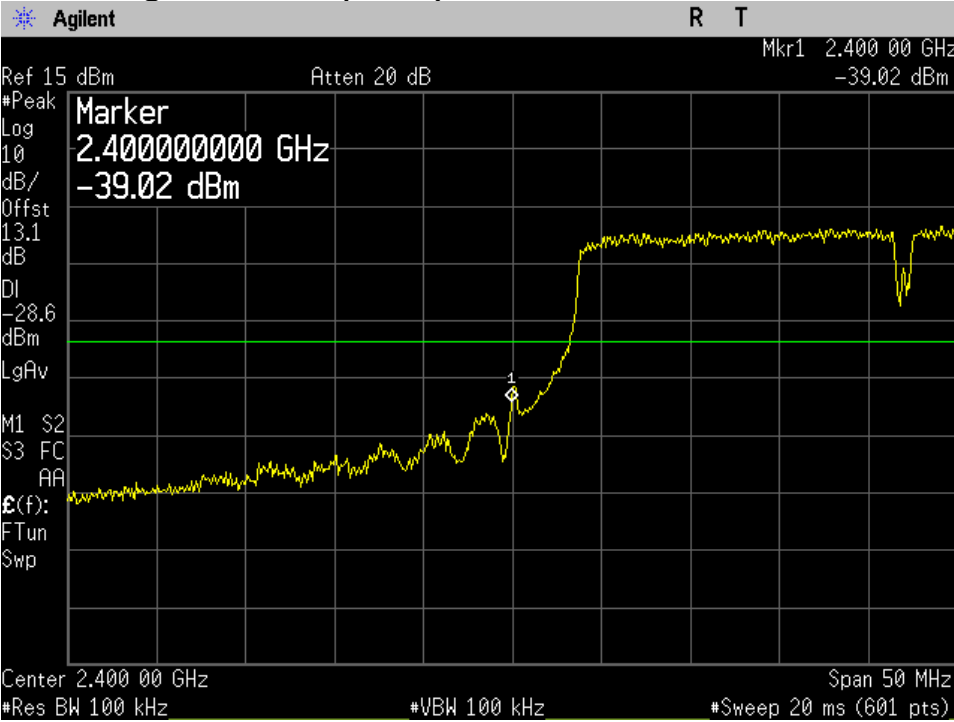

**Band Edge , 802.11n(HT40) mode, Highest Channel**

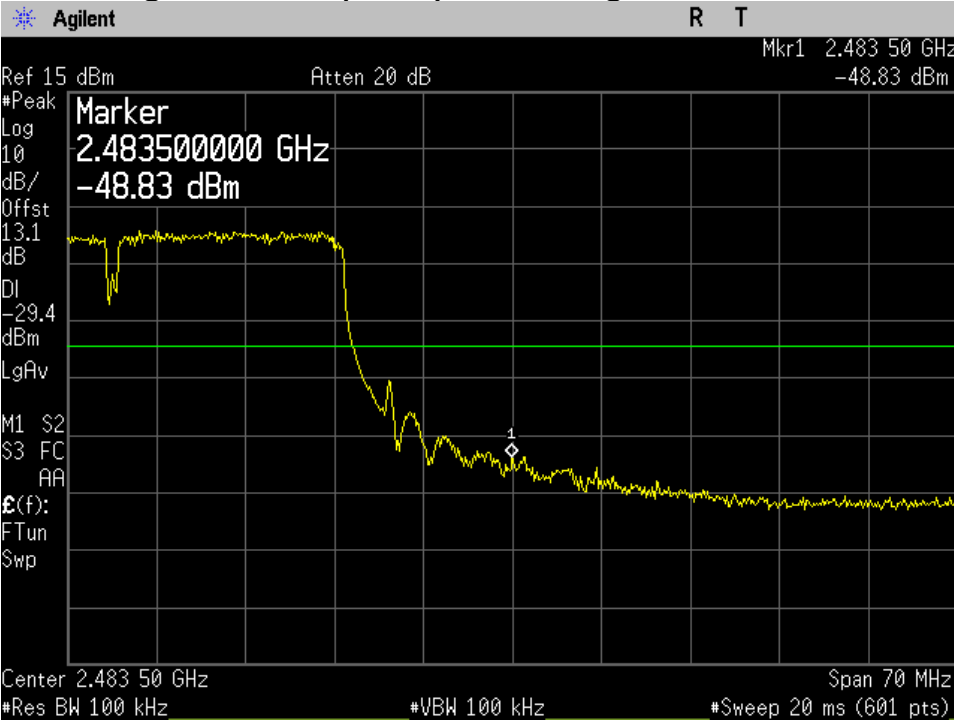

# TEST DATA

## 8.7 Radiated Spurious Emissions

FCC §15.247(d), IC RSS-210 Clause 2.6, IC RSS-GEN Clause 6

Test Mode : Set to Lowest channel, Middle channel and Highest channel

Result:

### 802.11b mode

#### Lowest Channel

Frequency (MHz)	Reading (dB $\mu$ N)	Pol* (H/V)	mode	AF+CL+Amp (dB)**	Result (dB $\mu$ N/m)	Limit (dB $\mu$ N/m)	Margin (dB)
1439.00	46.9	V	peak	-4.7	42.2	74.0	31.8
1439.00	35.6	V	average	-4.7	30.9	54.0	23.1
1650.00	46.3	H	peak	-4.1	42.2	74.0	31.8
1650.00	38.8	H	average	-4.1	34.7	54.0	19.3
1980.00	46.8	V	peak	-3.5	43.3	74.0	30.7
1980.00	36.9	V	average	-3.5	33.4	54.0	20.6
2310.00	48.4	V	peak	-2.2	46.2	74.0	27.8
2310.00	39.7	V	average	-2.2	37.5	54.0	16.5
4824.00	43.1	H	peak	8.7	51.8	74.0	22.2
4824.00	34.0	H	average	8.7	42.7	54.0	11.3
7987.12	43.0	V	peak	16.7	59.7	74.0	14.3
7987.12	31.7	V	average	16.7	48.4	54.0	5.6

## TEST DATA

### Middle Channel

Frequency (MHz)	Reading (dB $\mu$ N)	Pol* (H/V)	mode	AF+CL+Amp (dB)**	Result (dB $\mu$ N/m)	Limit (dB $\mu$ N/m)	Margin (dB)
1650.00	46.9	H	peak	-4.1	42.8	74.0	31.2
1650.00	38.9	H	average	-4.1	34.8	54.0	19.2
1980.00	46.5	V	peak	-3.5	43.0	74.0	31.0
1980.00	36.9	V	average	-3.5	33.4	54.0	20.6
2310.00	47.0	V	peak	-2.2	44.8	74.0	29.2
2310.00	39.1	V	average	-2.2	36.9	54.0	17.1
4874.00	45.5	H	peak	8.9	54.4	74.0	19.6
4874.00	36.1	H	average	8.9	45.0	54.0	9.0
5452.12	43.0	H	peak	9.8	52.8	74.0	21.2
5452.12	31.6	H	average	9.8	41.4	54.0	12.6

### Highest Channel

Frequency (MHz)	Reading (dB $\mu$ N)	Pol* (H/V)	mode	AF+CL+Amp (dB)**	Result (dB $\mu$ N/m)	Limit (dB $\mu$ N/m)	Margin (dB)
1341.00	47.4	H	peak	-5.0	42.4	74.0	31.6
1341.00	36.8	H	average	-5.0	31.8	54.0	22.2
1650.00	45.7	H	peak	-4.1	41.6	74.0	32.4
1650.00	38.2	H	average	-4.1	34.1	54.0	19.9
1980.00	45.8	V	peak	-3.5	42.3	74.0	31.7
1980.00	37.7	V	average	-3.5	34.2	54.0	19.8
2310.00	45.6	V	peak	-2.2	43.4	74.0	30.6
2310.00	38.9	V	average	-2.2	36.7	54.0	17.3
4924.00	47.2	H	peak	9.0	56.2	74.0	17.8
4924.00	36.6	H	average	9.0	45.6	54.0	8.4
6885.37	43.3	V	peak	13.8	57.1	74.0	16.9
6885.37	31.6	V	average	13.8	45.4	54.0	8.6

# TEST DATA

## 802.11g mode

### Lowest Channel

Frequency (MHz)	Reading (dB $\mu$ N)	Pol* (H/V)	mode	AF+CL+Amp (dB)**	Result (dB $\mu$ N/m)	Limit (dB $\mu$ N/m)	Margin (dB)
1044.00	47.7	H	peak	-5.9	41.8	74.0	32.2
1044.00	37.3	H	average	-5.9	31.4	54.0	22.6
1650.00	46.1	H	peak	-4.1	42.0	74.0	32.0
1650.00	38.0	H	average	-4.1	33.9	54.0	20.1
1980.00	45.8	V	peak	-3.5	42.3	74.0	31.7
1980.00	36.9	V	average	-3.5	33.4	54.0	20.6
2310.00	46.3	V	peak	-2.2	44.1	74.0	29.9
2310.00	39.5	V	average	-2.2	37.3	54.0	16.7
4824.00	42.4	H	peak	8.7	51.1	74.0	22.9
4824.00	32.3	H	average	8.7	41.0	54.0	13.0

### Middle Channel

Frequency (MHz)	Reading (dB $\mu$ N)	Pol* (H/V)	mode	AF+CL+Amp (dB)**	Result (dB $\mu$ N/m)	Limit (dB $\mu$ N/m)	Margin (dB)
1650.00	45.9	H	peak	-4.1	41.8	74.0	32.2
1650.00	37.7	H	average	-4.1	33.6	54.0	20.4
1980.00	45.1	V	peak	-3.5	41.6	74.0	32.4
1980.00	37.2	V	average	-3.5	33.7	54.0	20.3
2310.00	46.4	V	peak	-2.2	44.2	74.0	29.8
2310.00	39.7	V	average	-2.2	37.5	54.0	16.5
4874.00	44.5	H	peak	8.9	53.4	74.0	20.6
4874.00	33.8	H	average	8.9	42.7	54.0	11.3
6178.50	43.7	H	peak	11.0	54.7	74.0	19.3
6178.50	33.8	H	average	11.0	44.8	54.0	9.2

# TEST DATA

## Highest Channel

Frequency (MHz)	Reading (dB $\mu$ V)	Pol* (H/V)	mode	AF+CL+Amp (dB)**	Result (dB $\mu$ V/m)	Limit (dB $\mu$ V/m)	Margin (dB)
1650.00	46.1	H	peak	-4.1	42.0	74.0	32.0
1650.00	38.3	H	average	-4.1	34.2	54.0	19.8
1980.00	45.3	V	peak	-3.5	41.8	74.0	32.2
1980.00	37.1	V	average	-3.5	33.6	54.0	20.4
2310.00	46.4	V	peak	-2.2	44.2	74.0	29.8
2310.00	39.8	V	average	-2.2	37.6	54.0	16.4
3107.23	45.3	V	peak	4.1	49.4	74.0	24.6
3107.23	34.3	V	average	4.1	38.4	54.0	15.6
4924.00	44.3	H	peak	9.0	53.3	74.0	20.7
4924.00	33.8	H	average	9.0	42.8	54.0	11.2

## 802.11n(HT20) mode

### Lowest Channel

Frequency (MHz)	Reading (dB $\mu$ V)	Pol* (H/V)	mode	AF+CL+Amp (dB)**	Result (dB $\mu$ V/m)	Limit (dB $\mu$ V/m)	Margin (dB)
1650.00	46.1	H	peak	-4.1	42.0	74.0	32.0
1650.00	38.4	H	average	-4.1	34.3	54.0	19.7
1808.00	47.2	V	peak	-3.9	43.3	74.0	30.7
1808.00	35.6	V	average	-3.9	31.7	54.0	22.3
1980.00	46.6	H	peak	-3.5	43.1	74.0	30.9
1980.00	36.9	H	average	-3.5	33.4	54.0	20.6
2310.00	46.4	V	peak	-2.2	44.2	74.0	29.8
2310.00	39.1	V	average	-2.2	36.9	54.0	17.1
4824.00	44.5	H	peak	8.6	53.1	74.0	20.9
4824.00	34.0	H	average	8.6	42.6	54.0	11.4

# TEST DATA

## Middle Channel

Frequency (MHz)	Reading (dB $\mu$ V)	Pol* (H/V)	mode	AF+CL+Amp (dB)**	Result (dB $\mu$ V/m)	Limit (dB $\mu$ V/m)	Margin (dB)
1650.00	46.4	H	peak	-4.1	42.3	74.0	31.7
1650.00	39.2	H	average	-4.1	35.1	54.0	18.9
1980.00	45.3	V	peak	-3.5	41.8	74.0	32.2
1980.00	36.5	V	average	-3.5	33.0	54.0	21.0
2310.00	47.1	V	peak	-2.2	44.9	74.0	29.1
2310.00	40.6	V	average	-2.2	38.4	54.0	15.6
3214.00	44.9	V	peak	4.4	49.3	74.0	24.7
3214.00	33.4	V	average	4.4	37.8	54.0	16.2
4874.00	42.3	H	peak	8.9	51.2	74.0	22.8
4874.00	33.0	H	average	8.9	41.9	54.0	12.1
5096.25	43.6	V	peak	9.4	53.0	74.0	21.0
5096.25	31.6	V	average	9.4	41.0	54.0	13.0

## Highest Channel

Frequency (MHz)	Reading (dB $\mu$ V)	Pol* (H/V)	mode	AF+CL+Amp (dB)**	Result (dB $\mu$ V/m)	Limit (dB $\mu$ V/m)	Margin (dB)
1650.00	45.7	H	peak	-4.1	41.6	74.0	32.4
1650.00	38.5	H	average	-4.1	34.4	54.0	19.6
1980.00	45.8	V	peak	-3.5	42.3	74.0	31.7
1980.00	36.6	V	average	-3.5	33.1	54.0	20.9
2310.00	47.7	V	peak	-2.2	45.5	74.0	28.5
2310.00	40.2	V	average	-2.2	38.0	54.0	16.0
4924.00	44.2	H	peak	9.0	53.2	74.0	20.8
4924.00	35.0	H	average	9.0	44.0	54.0	10.0
5944.50	42.6	V	peak	10.6	53.2	74.0	20.8
5944.50	31.4	V	average	10.6	42.0	54.0	12.0

# TEST DATA

## 802.11n(HT40) mode

### Lowest Channel

Frequency (MHz)	Reading (dB $\mu$ V)	Pol* (H/V)	mode	AF+CL+Amp (dB)**	Result (dB $\mu$ N/m)	Limit (dB $\mu$ N/m)	Margin (dB)
1113.00	47.3	H	peak	-5.7	41.6	74.0	32.4
1113.00	36.0	H	average	-5.7	30.3	54.0	23.7
2310.00	46.5	H	peak	-2.2	44.3	74.0	29.7
2310.00	37.1	H	average	-2.2	34.9	54.0	19.1
2792.00	47.3	H	peak	-0.1	47.2	74.0	26.8
2792.00	35.4	H	average	-0.1	35.3	54.0	18.7
4844.00	42.5	V	peak	8.7	51.2	74.0	22.8
4844.00	33.6	V	average	8.7	42.3	54.0	11.7
6276.00	42.1	H	peak	11.5	53.6	74.0	20.4
6276.00	31.0	H	average	11.5	42.5	54.0	11.5

### Middle Channel

Frequency (MHz)	Reading (dB $\mu$ V)	Pol* (H/V)	mode	AF+CL+Amp (dB)**	Result (dB $\mu$ N/m)	Limit (dB $\mu$ N/m)	Margin (dB)
1009.00	47.3	V	peak	-6.0	41.3	74.0	32.7
1009.00	37.4	V	average	-6.0	31.4	54.0	22.6
1650.00	45.8	H	peak	-4.1	41.7	74.0	32.3
1650.00	38.9	H	average	-4.1	34.8	54.0	19.2
2310.00	47.1	V	peak	-2.2	44.9	74.0	29.1
2310.00	39.8	V	average	-2.2	37.6	54.0	16.4
4874.00	42.6	V	peak	8.9	51.5	74.0	22.5
4874.00	33.7	V	average	8.9	42.6	54.0	11.4
5418.00	43.0	V	peak	9.7	52.7	74.0	21.3
5418.00	32.1	V	average	9.7	41.8	54.0	12.2

# TEST DATA

## Highest Channel

Frequency (MHz)	Reading (dB $\mu$ V)	Pol* (H/V)	mode	AF+CL+Amp (dB)**	Result (dB $\mu$ V/m)	Limit (dB $\mu$ V/m)	Margin (dB)
1650.00	46.9	H	peak	-4.1	42.8	74.0	31.2
1650.00	40.3	H	average	-4.1	36.2	54.0	17.8
1971.00	48.1	H	peak	-3.5	44.6	74.0	29.4
1971.00	37.2	H	average	-3.5	33.7	54.0	20.3
2027.00	47.9	H	peak	-3.4	44.5	74.0	29.5
2027.00	36.1	H	average	-3.4	32.7	54.0	21.3
3658.00	44.4	V	peak	5.4	49.8	74.0	24.2
3658.00	32.8	V	average	5.4	38.2	54.0	15.8
4904.00	45.1	V	peak	8.9	54.0	74.0	20.0
4904.00	35.5	V	average	8.9	44.4	54.0	9.6

1. \*Pol. H=Horizontal V=Vertical
2. \*\*AF+CL+Amp. = Antenna Factor + Cable Loss + Amplifier.
3. Other spurious are 20 dB below than Fundamental.
4. The radiated emissions testing were made by rotating through three orthogonal axes.  
The worst date was recorded.
5. For measurements the resolution bandwidth is set to 1 MHz, and then the video bandwidth is set to 1 MHz for peak measurements and 10 Hz for average measurements.
6. The spectrum is measured from 9 kHz to 10<sup>th</sup> harmonic and the worst-case emissions are reported. No significant emissions were found beyond the fifth harmonic for this device.

# PLOT OF TEST DATA

## 802.11b mode

### **Restricted Band Spurious Emissions, 802.11b, Lowest channel Horizontal, Peak**

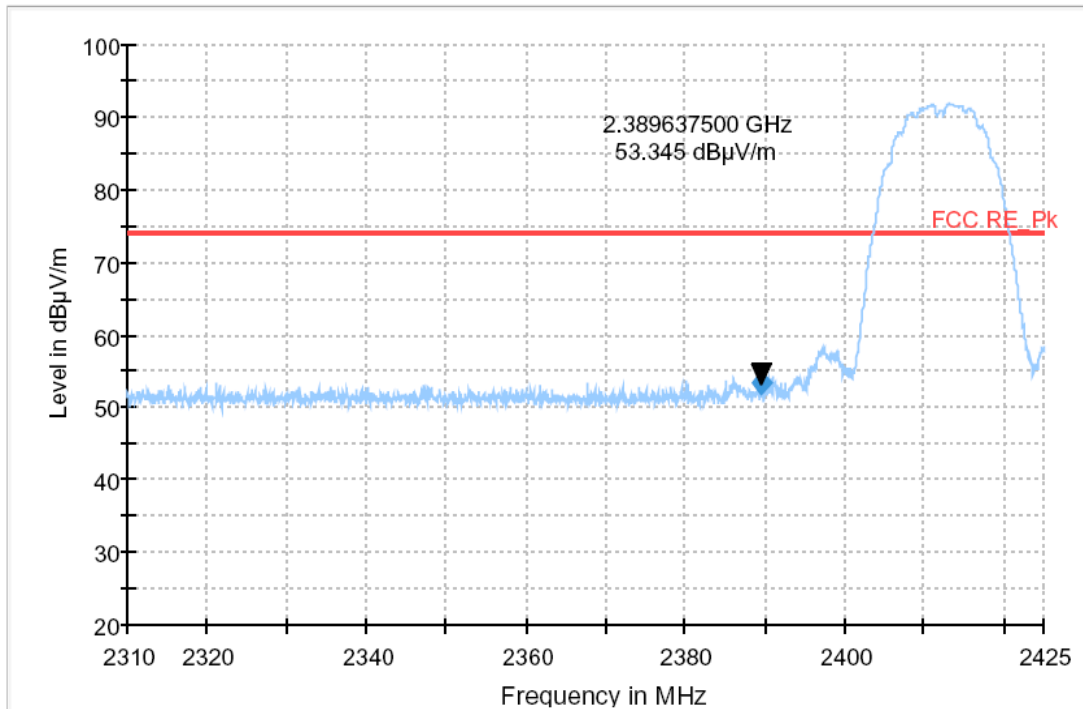

### **Restricted Band Spurious Emissions, 802.11b, Lowest channel Horizontal, Average**

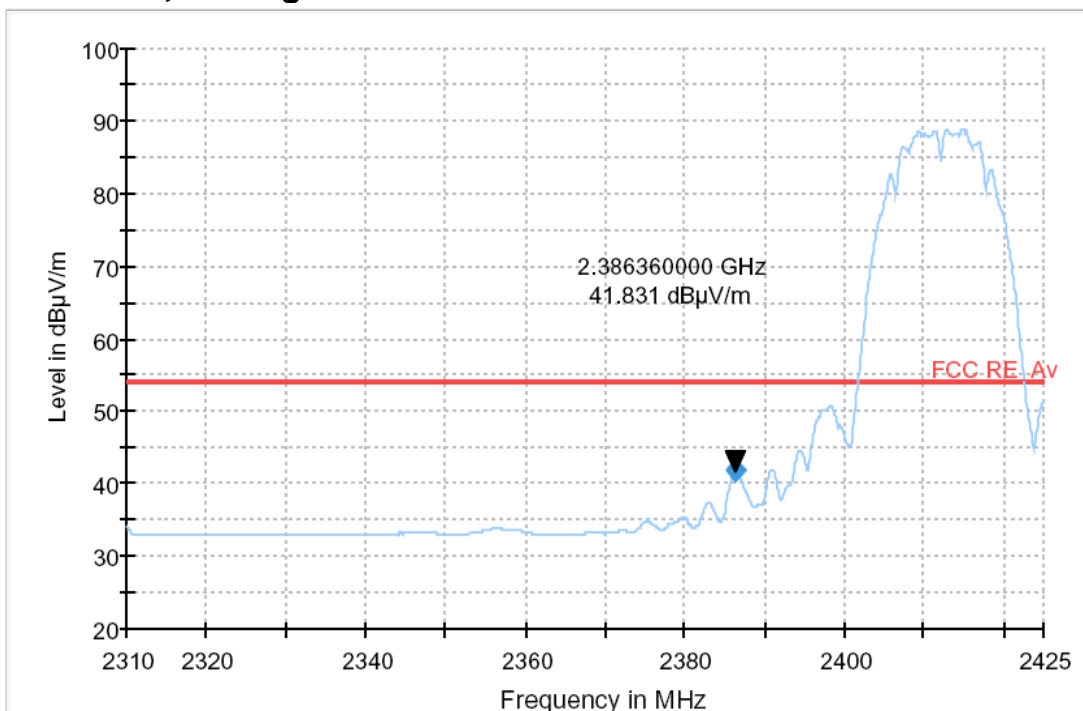

# PLOT OF TEST DATA

## Restricted Band Spurious Emissions, 802.11b, Lowest channel Vertical, Peak

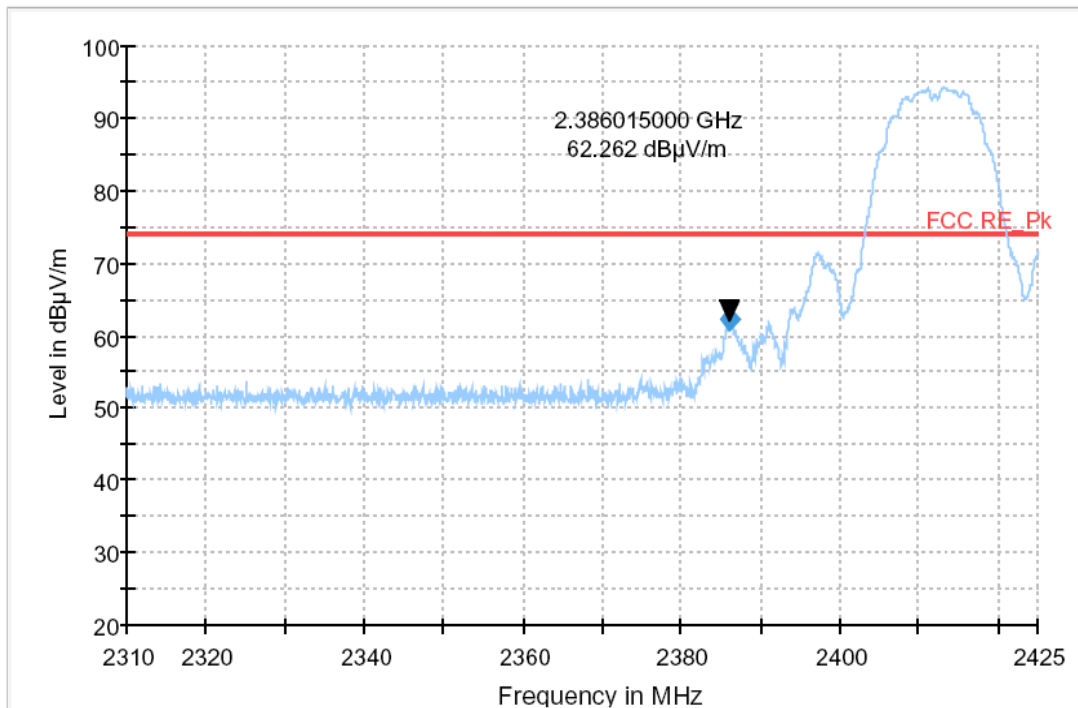

## Restricted Band Spurious Emissions, 802.11b, Lowest channel Vertical, Average

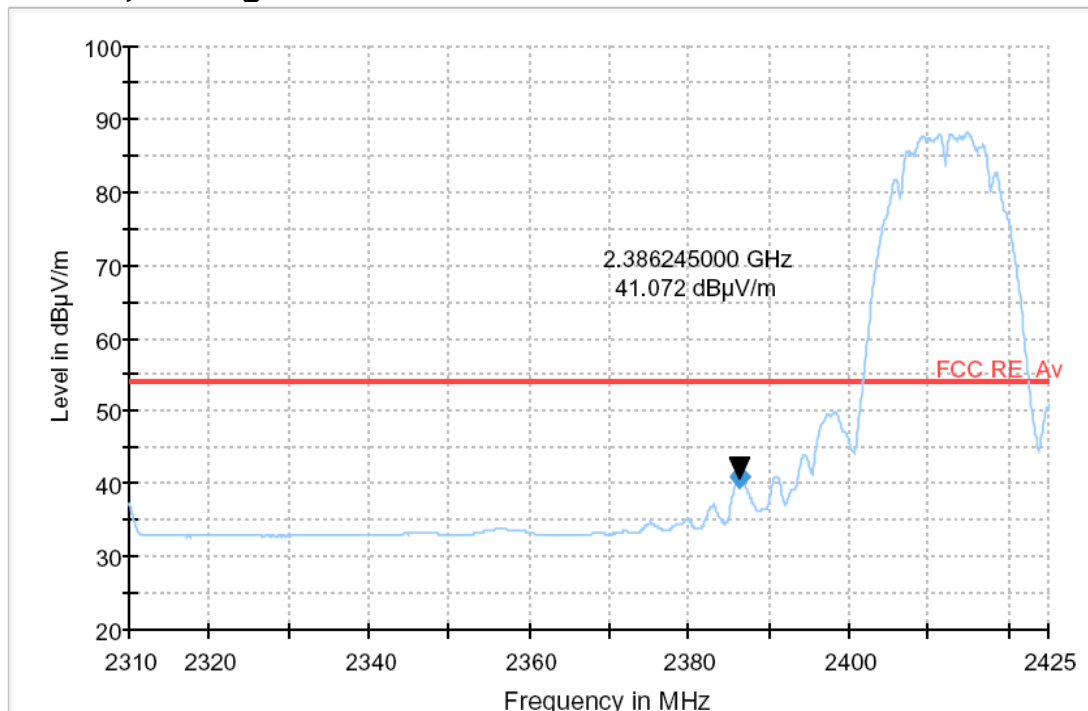

# PLOT OF TEST DATA

## Restricted Band Spurious Emissions, 802.11b, Highest channel Horizontal, Peak

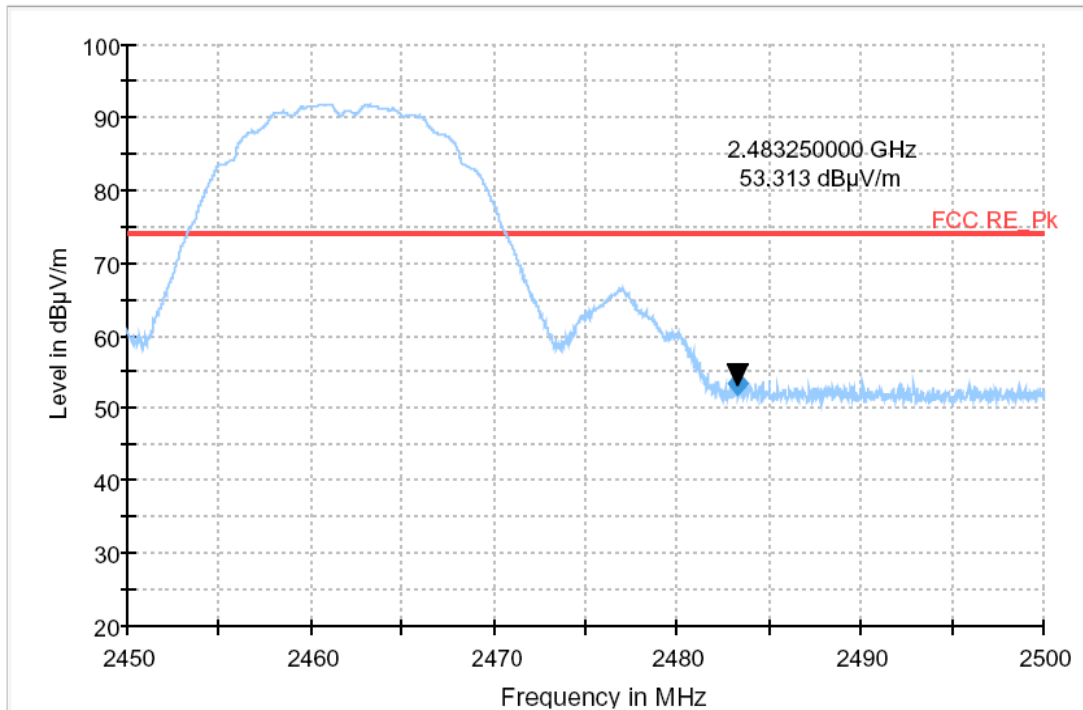

## Restricted Band Spurious Emissions, 802.11b, Highest channel Horizontal, Average

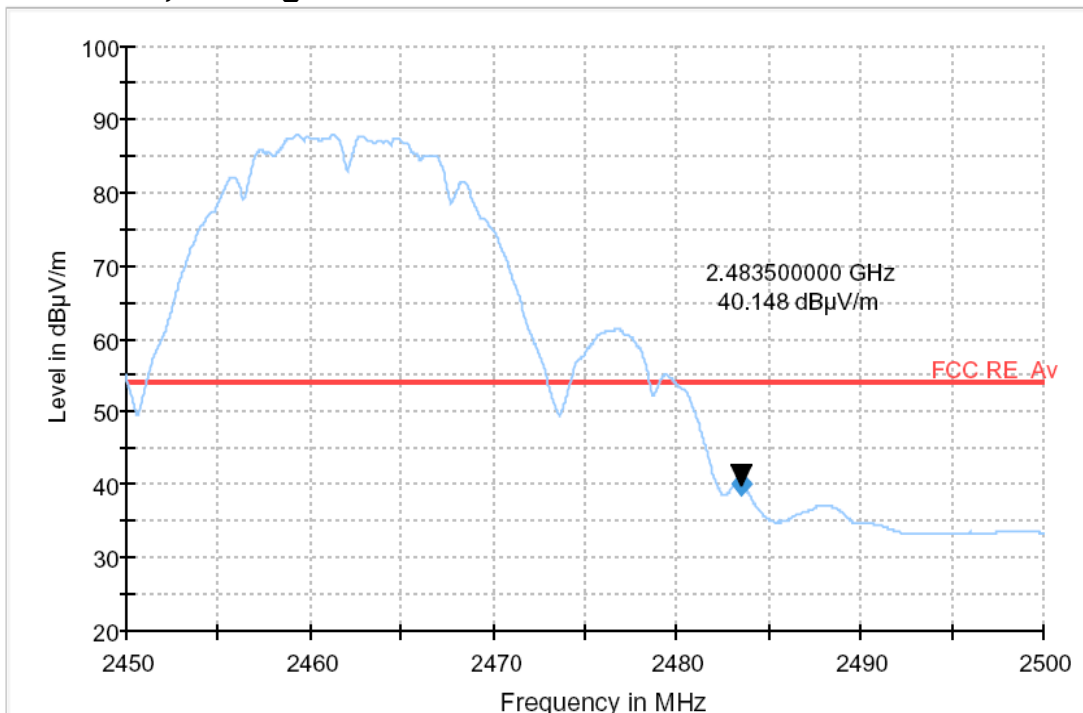

# PLOT OF TEST DATA

## Restricted Band Spurious Emissions, 802.11b, Highest channel Vertical, Peak

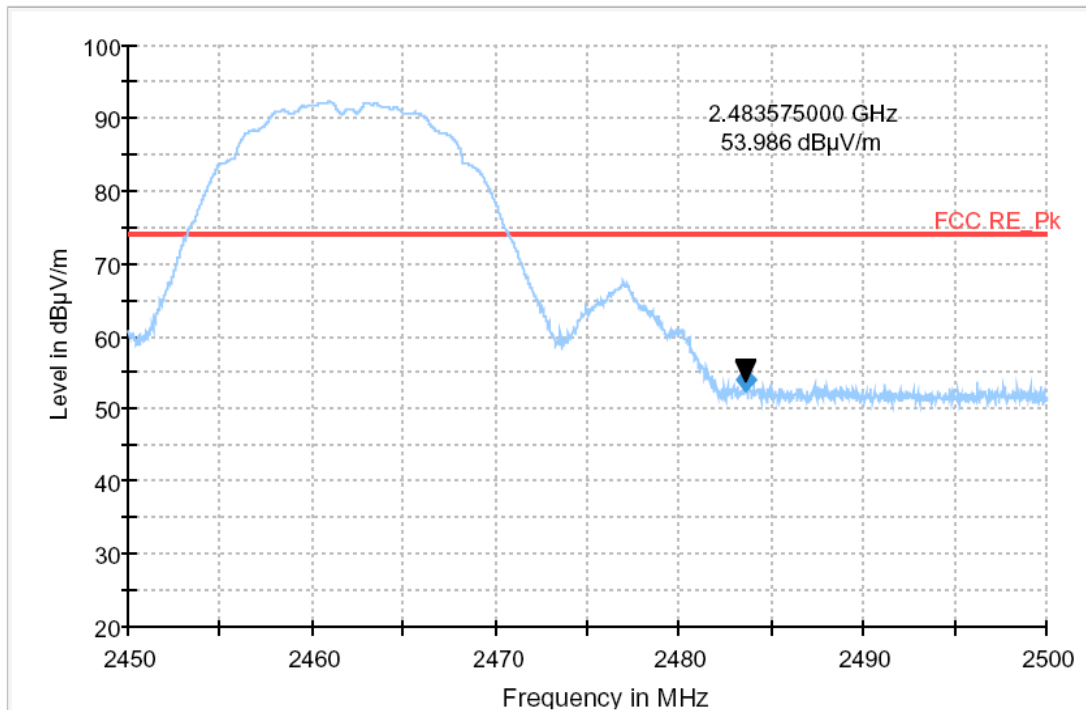

## Restricted Band Spurious Emissions, 802.11b, Highest channel Vertical, Average

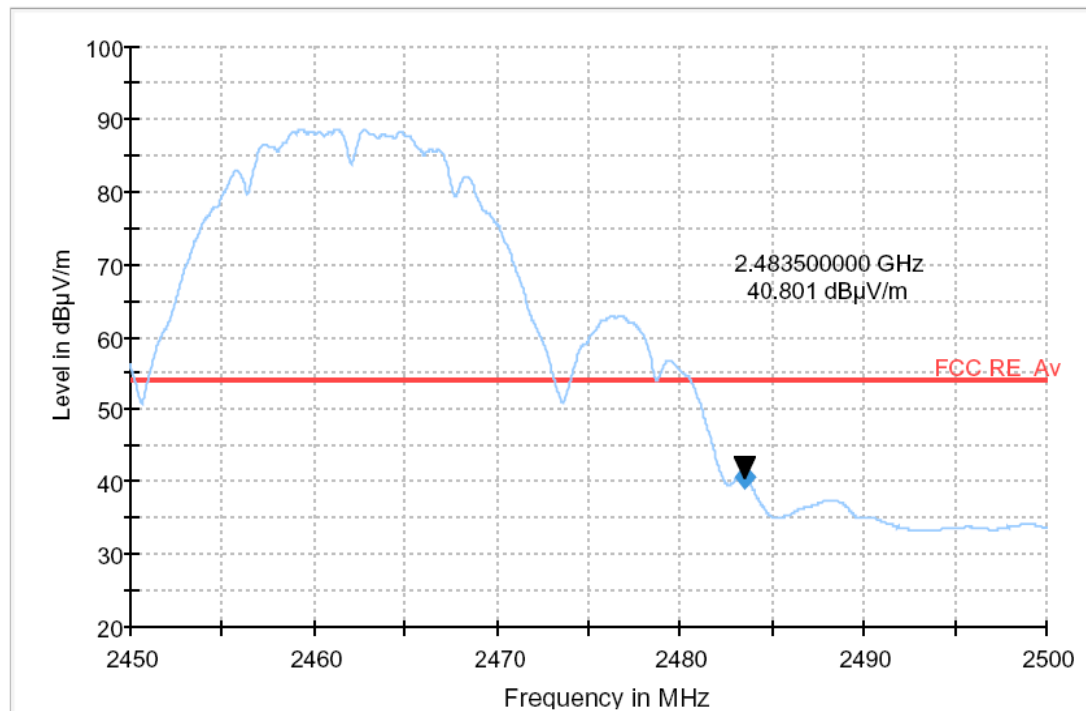

# PLOT OF TEST DATA

## 802.11g mode

### **Restricted Band Spurious Emissions, 802.11g, Lowest channel Horizontal, Peak**

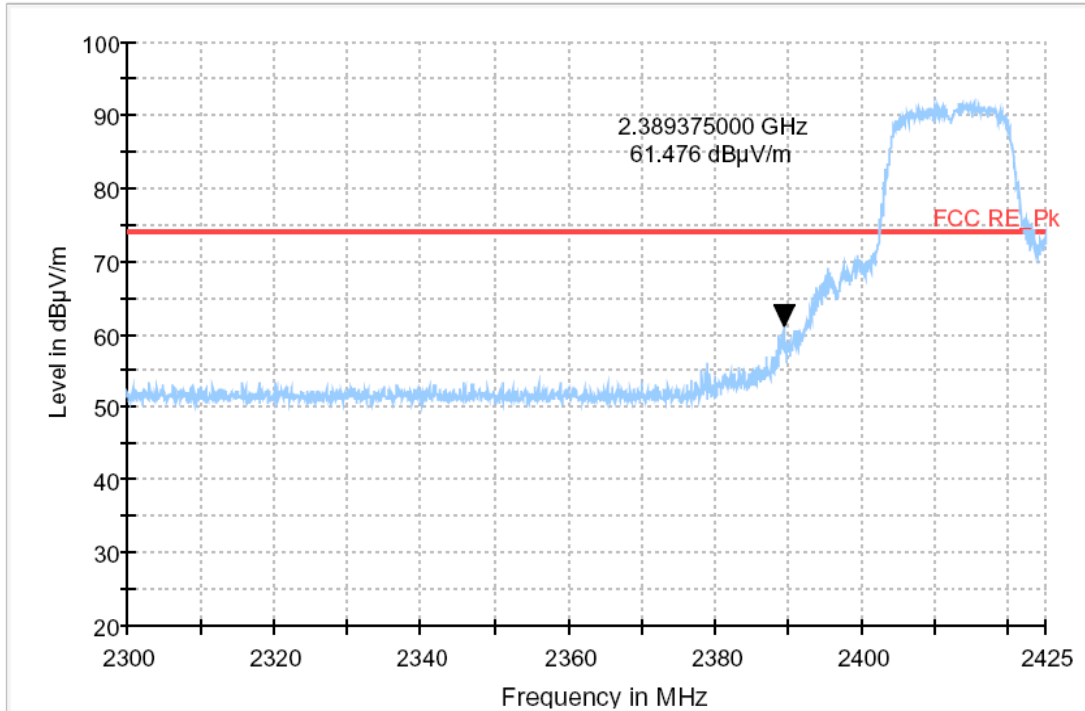

### **Restricted Band Spurious Emissions, 802.11g, Lowest channel Horizontal, Average**

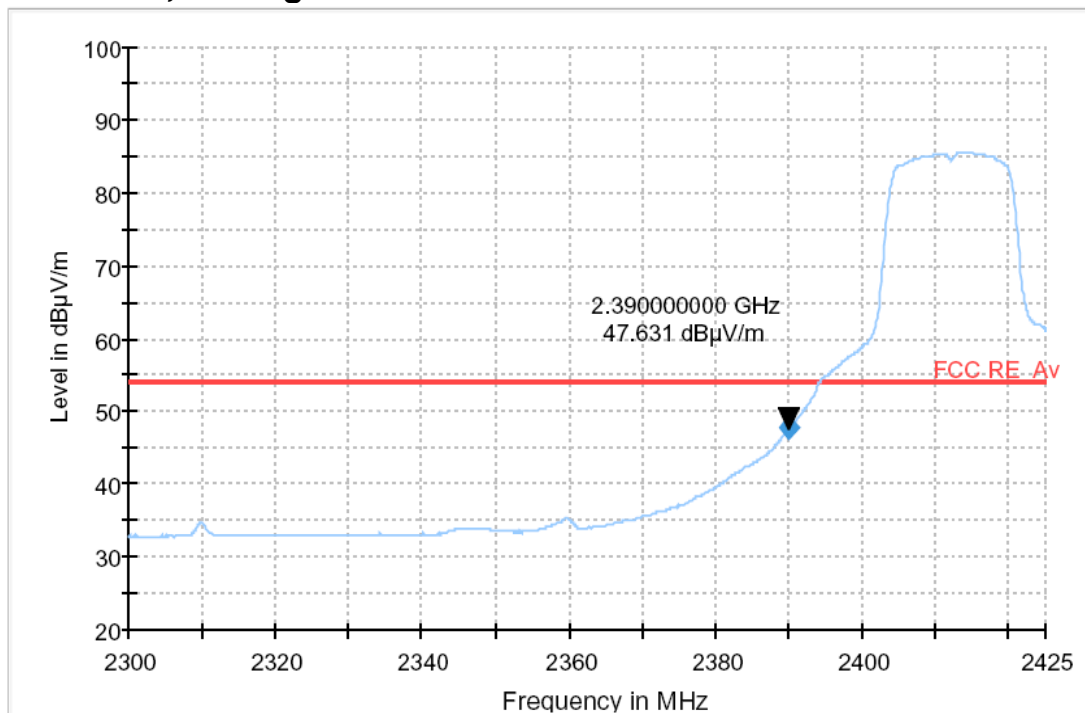

# PLOT OF TEST DATA

## Restricted Band Spurious Emissions, 802.11g, Lowest channel Vertical, Peak

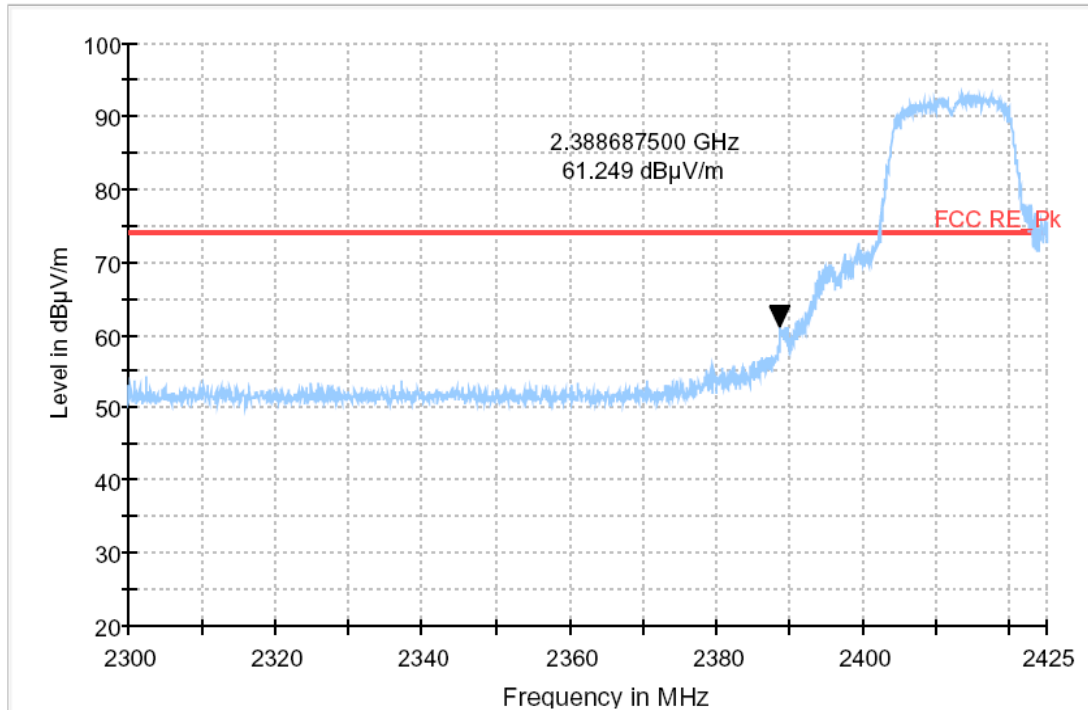

## Restricted Band Spurious Emissions, 802.11g, Lowest channel Vertical, Average

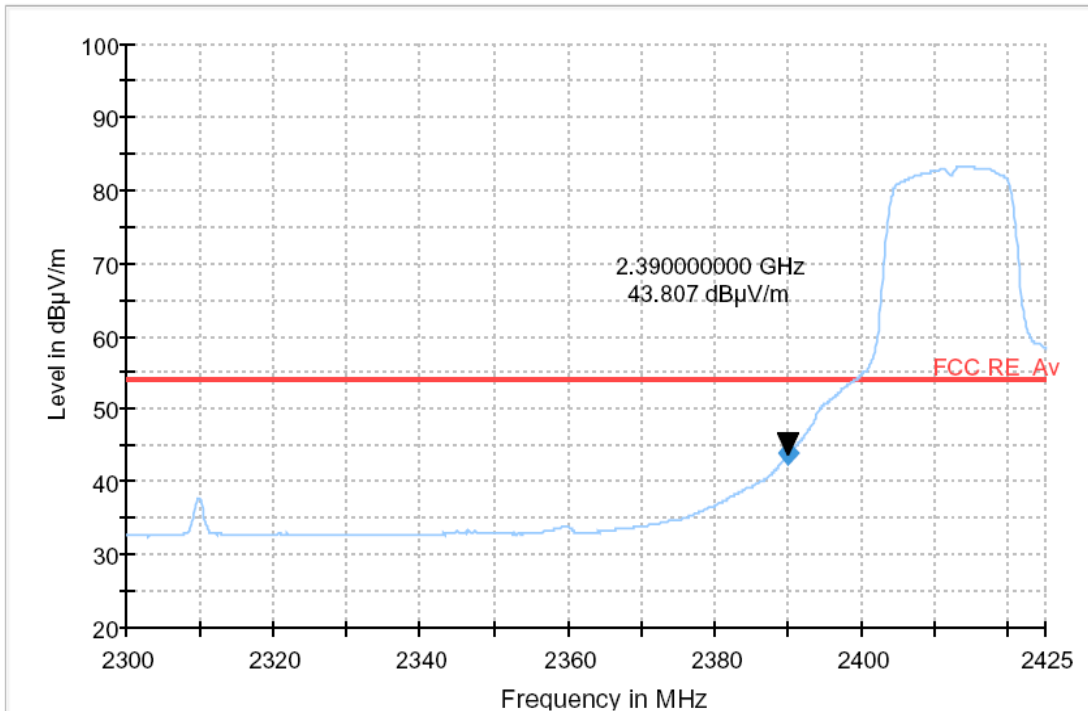

# PLOT OF TEST DATA

## Restricted Band Spurious Emissions, 802.11g, Highest channel Horizontal, Peak

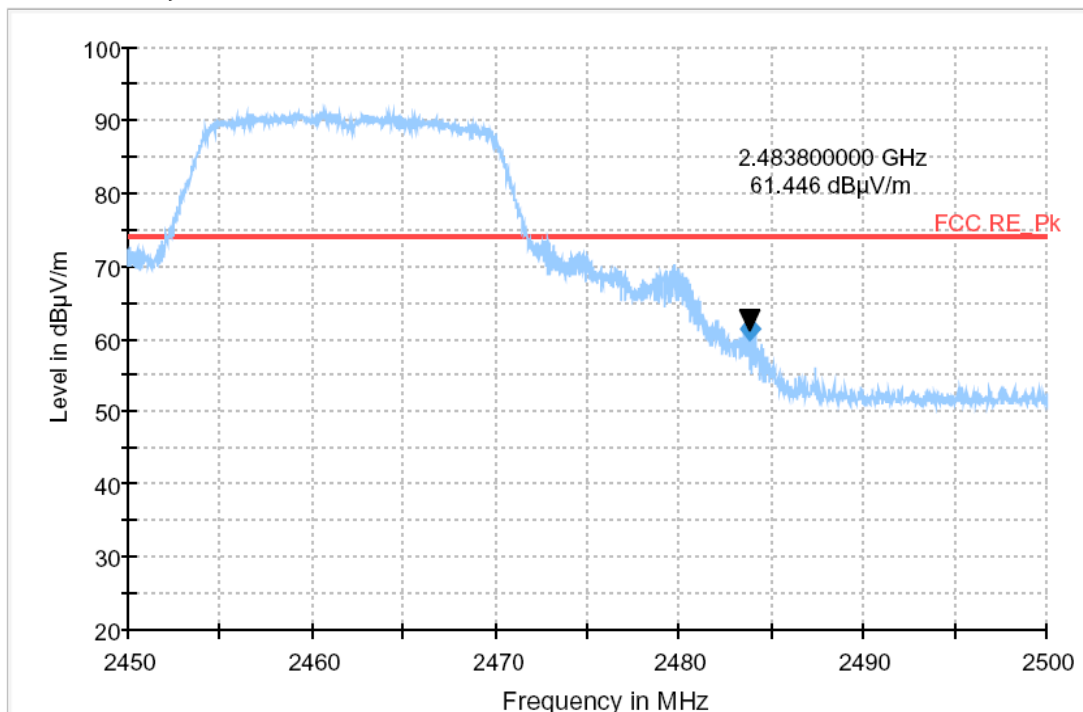

## Restricted Band Spurious Emissions, 802.11g, Highest channel Horizontal, Average

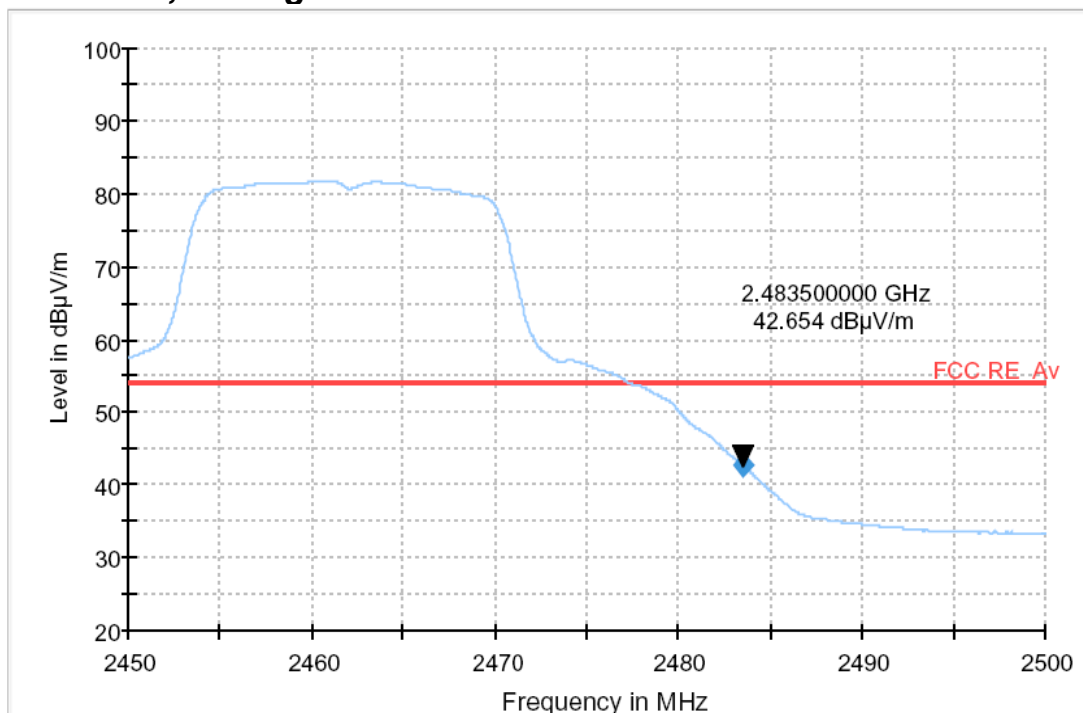

# PLOT OF TEST DATA

## Restricted Band Spurious Emissions, 802.11g, Highest channel Vertical, Peak

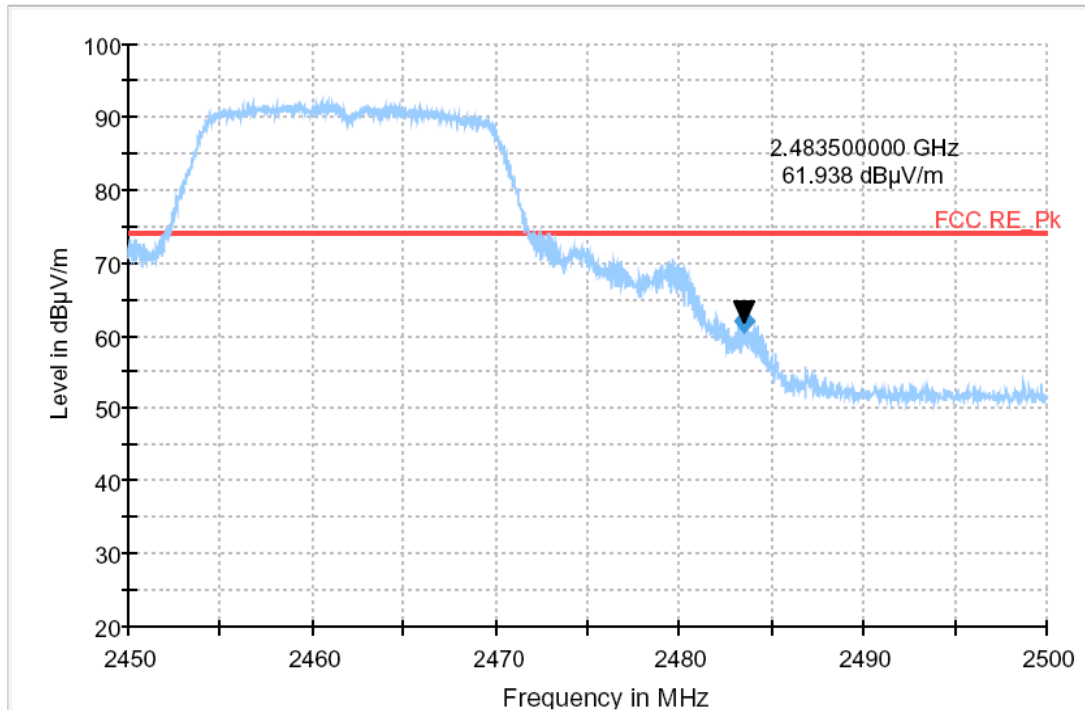

## Restricted Band Spurious Emissions, 802.11g, Highest channel Vertical, Average

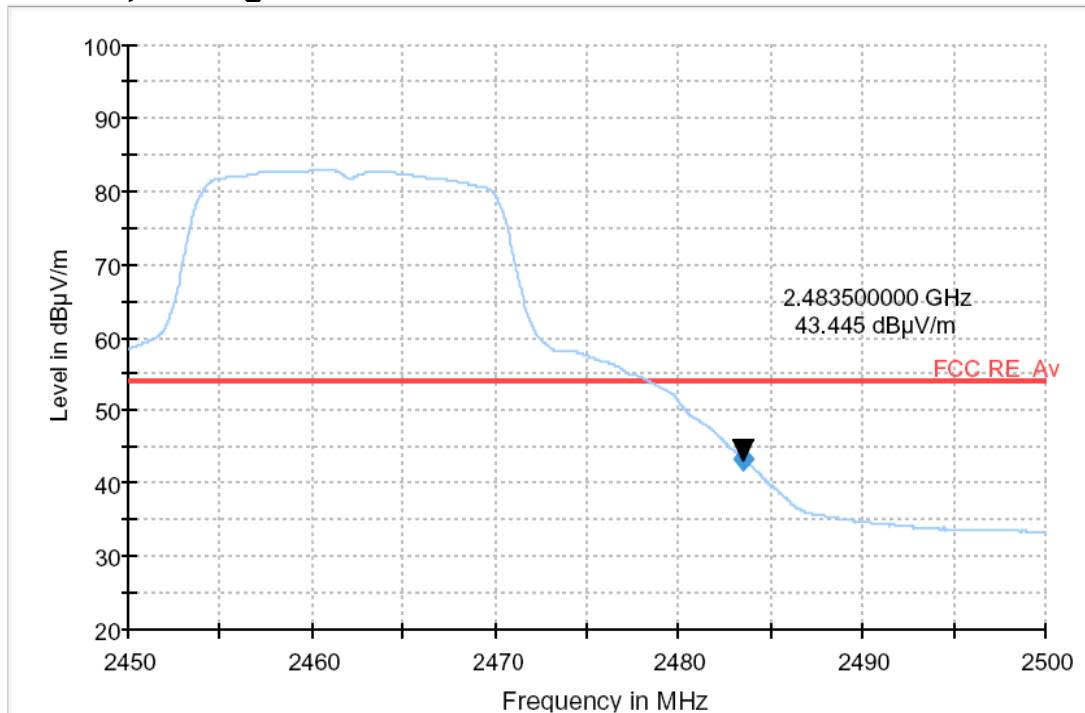

# PLOT OF TEST DATA

## 802.11n(HT20) mode

**Restricted Band Spurious Emissions, 802.11n(HT20), Lowest channel  
Horizontal, Peak**

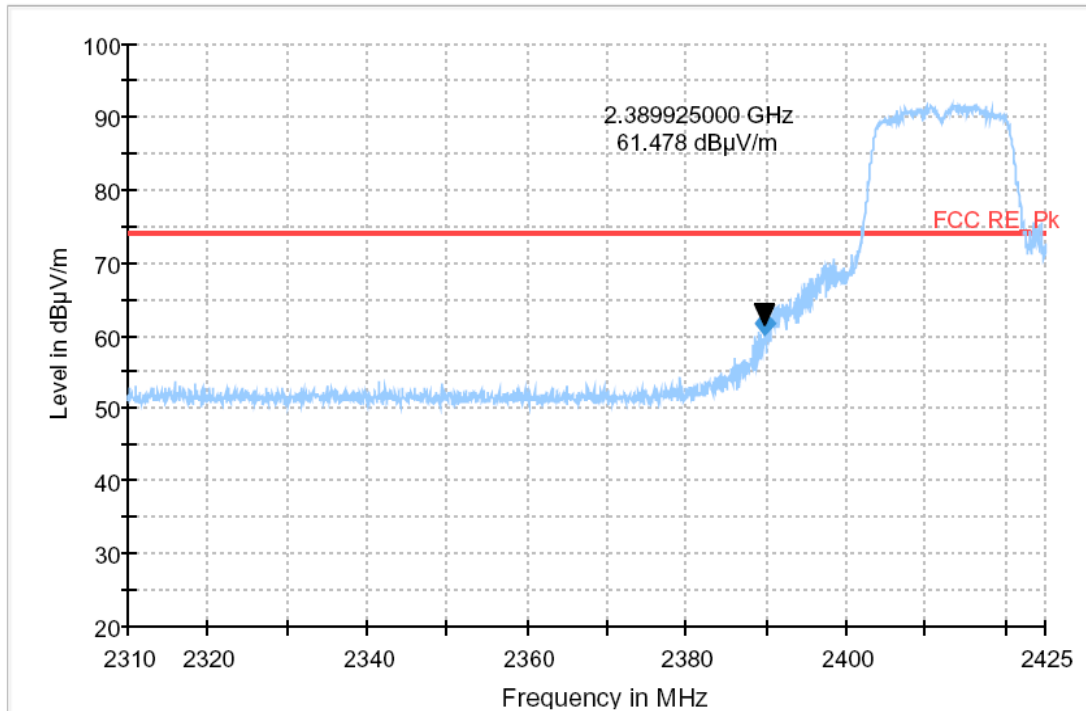

**Restricted Band Spurious Emissions, 802.11n(HT20), Lowest channel  
Horizontal, Average**

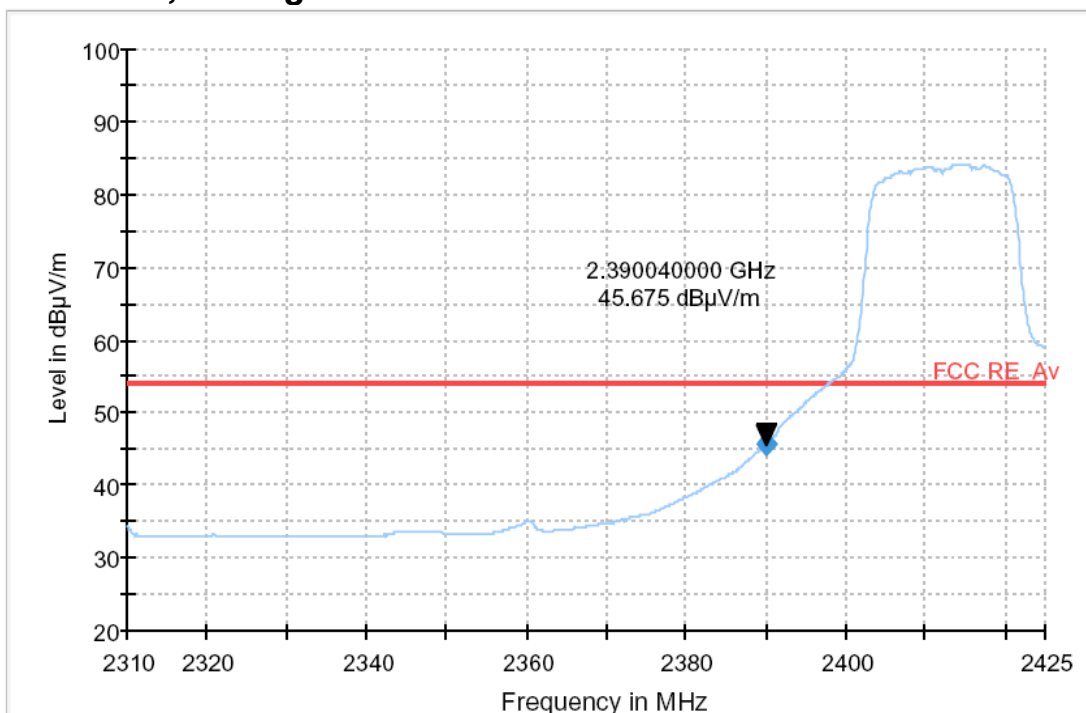

# PLOT OF TEST DATA

## Restricted Band Spurious Emissions, 802.11n(HT20), Lowest channel Vertical, Peak

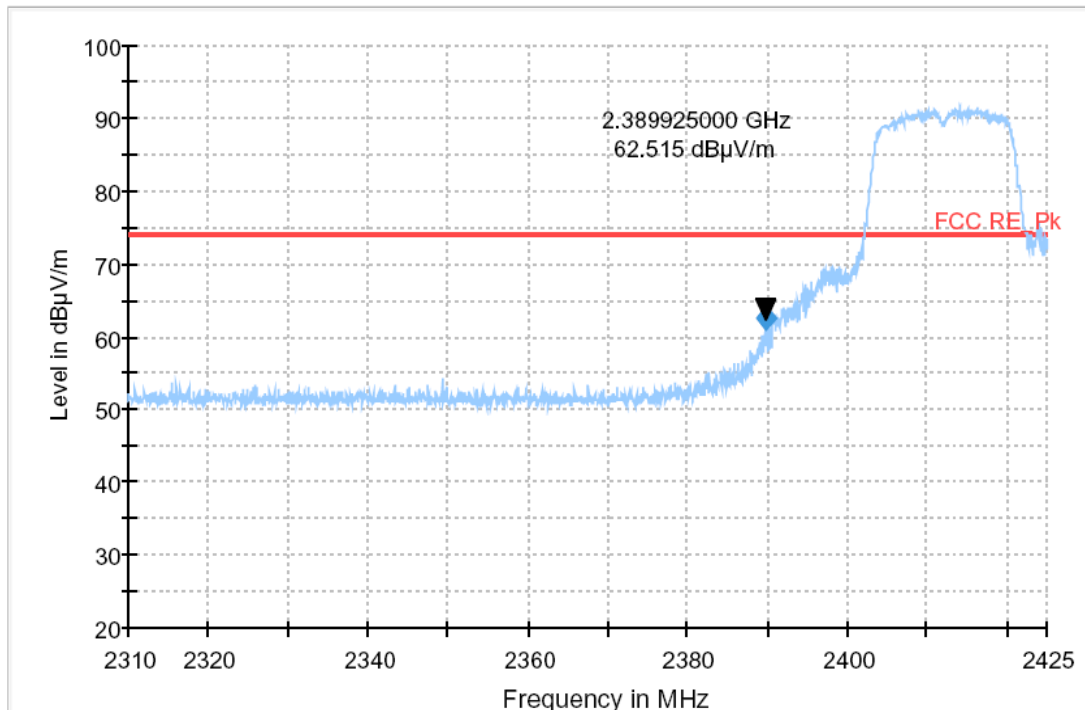

## Restricted Band Spurious Emissions, 802.11n(HT20), Lowest channel Vertical, Average

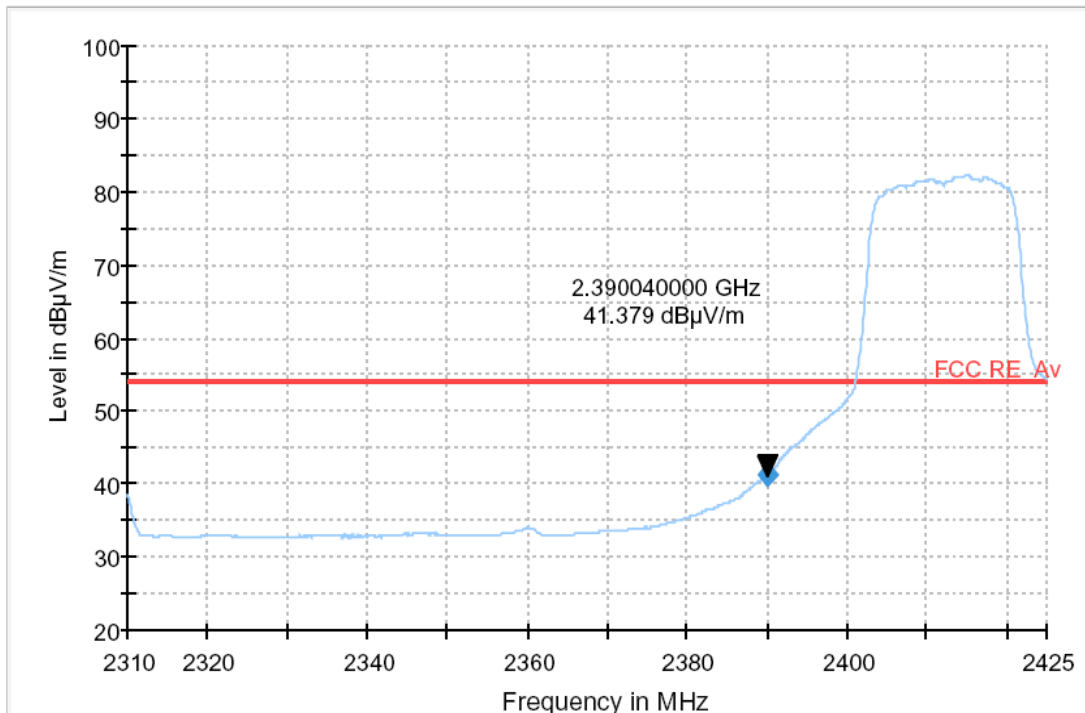

# PLOT OF TEST DATA

## Restricted Band Spurious Emissions, 802.11n(HT20), Highest channel Horizontal, Peak

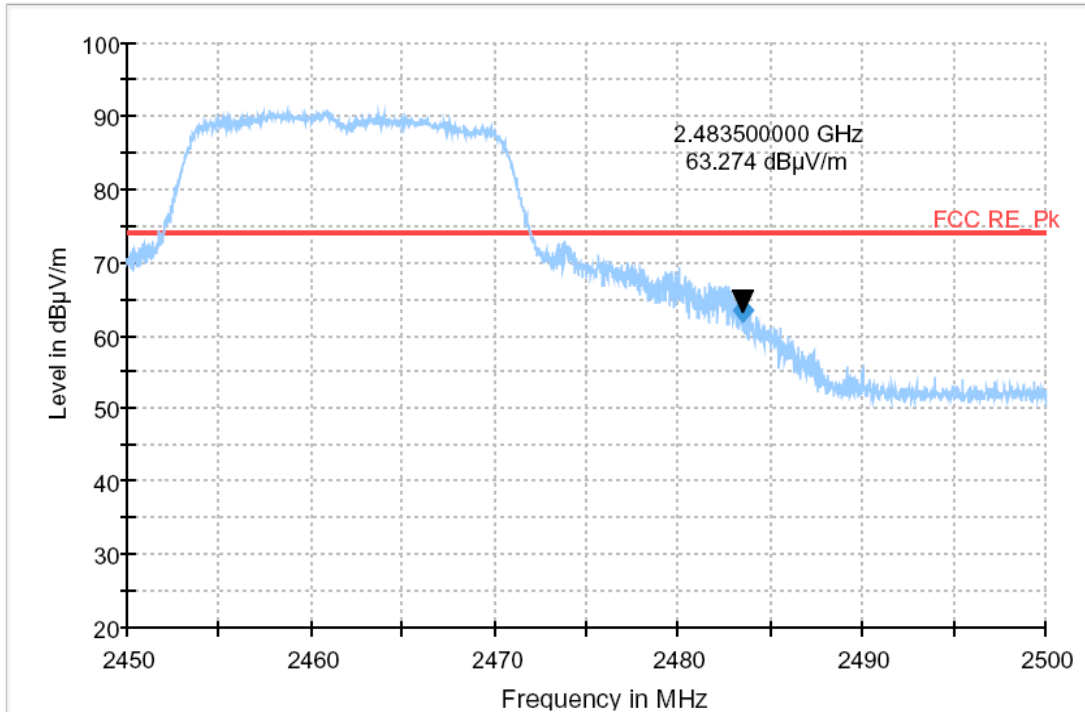

## Restricted Band Spurious Emissions, 802.11n(HT20), Highest channel Horizontal, Average

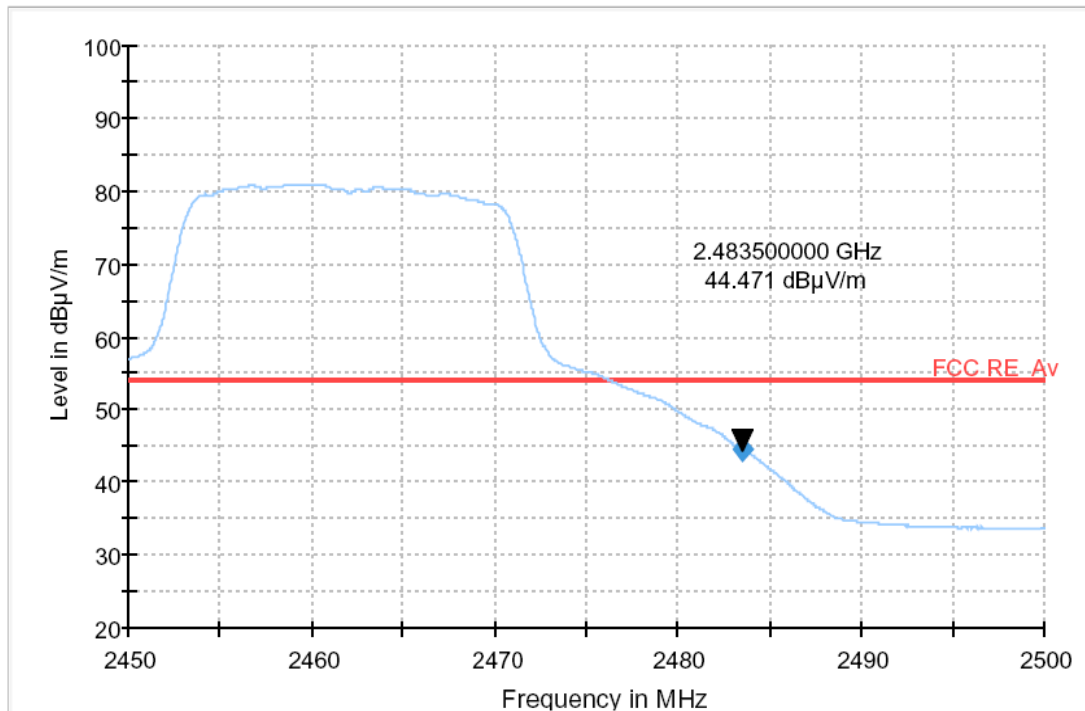

# PLOT OF TEST DATA

## Restricted Band Spurious Emissions, 802.11n(HT20), Highest channel Vertical, Peak

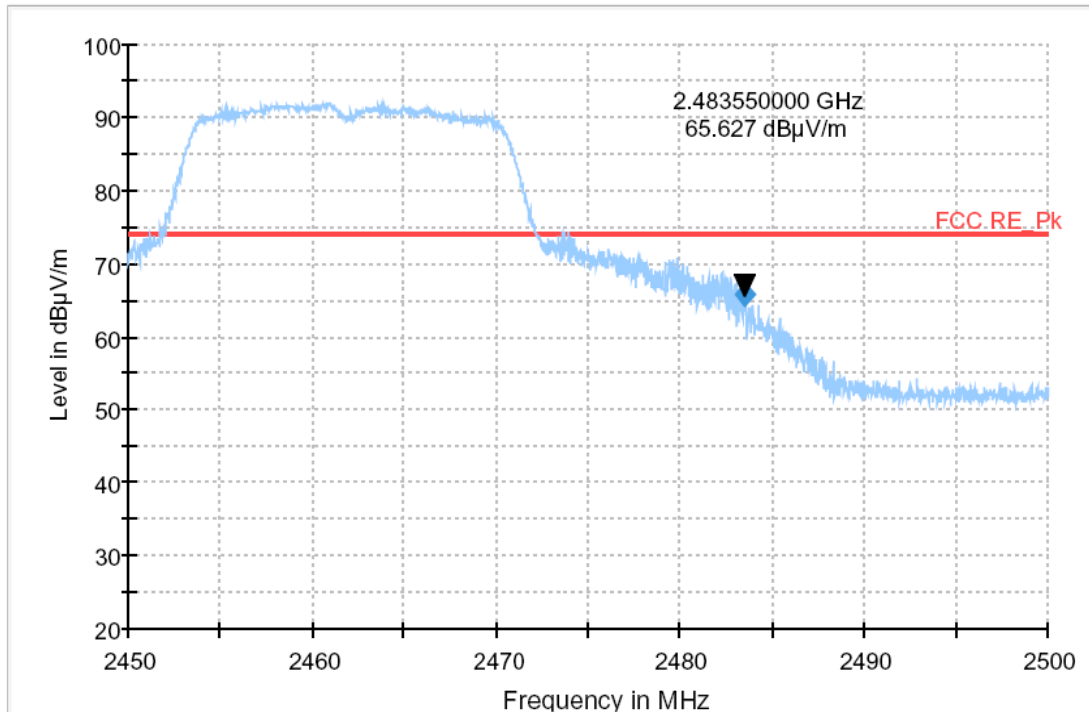

## Restricted Band Spurious Emissions, 802.11n(HT20), Highest channel Vertical, Average

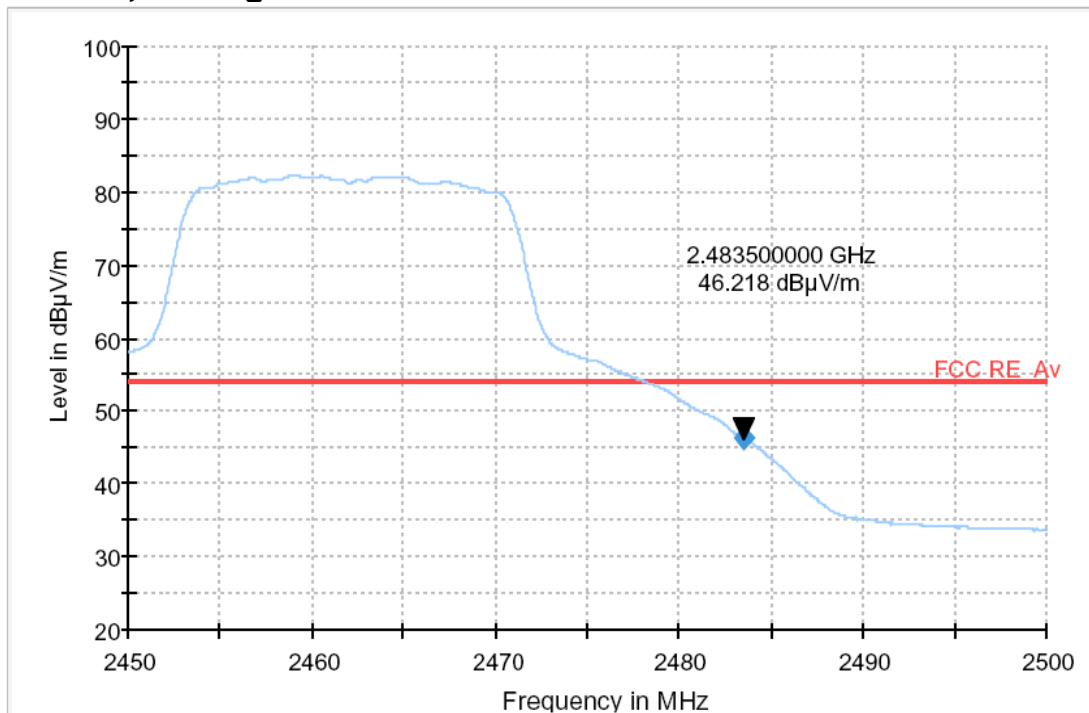

# PLOT OF TEST DATA

## 802.11n(HT40) mode

**Restricted Band Spurious Emissions, 802.11n(HT40), Lowest channel  
Horizontal, Peak**

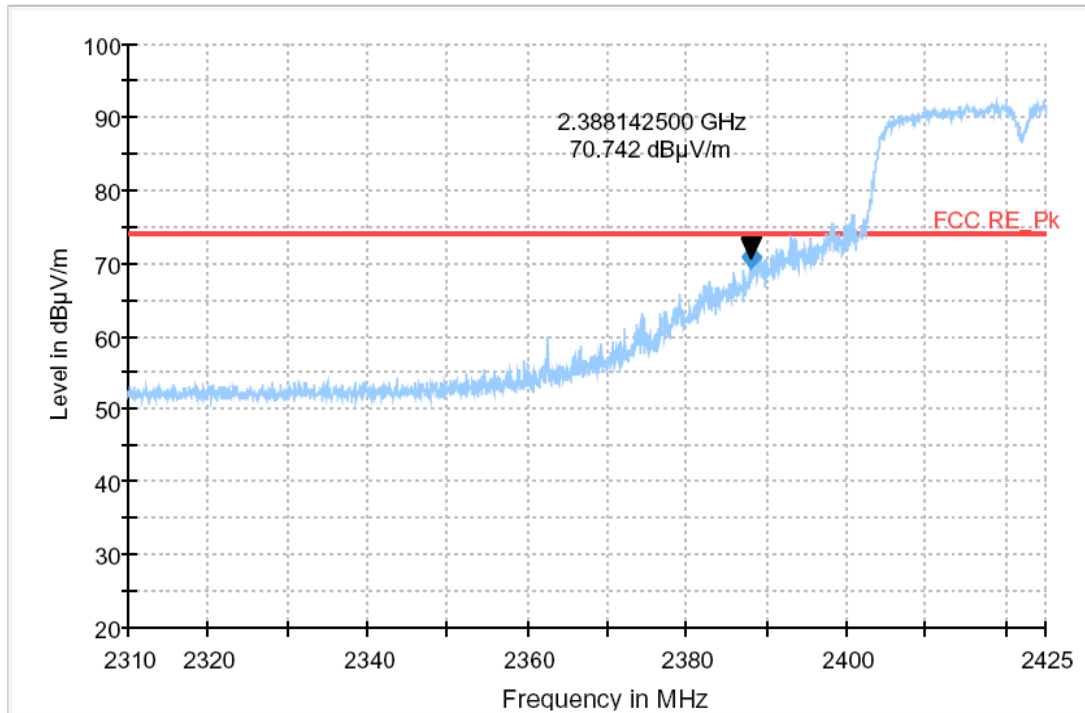

**Restricted Band Spurious Emissions, 802.11n(HT40), Lowest channel  
Horizontal, Average**

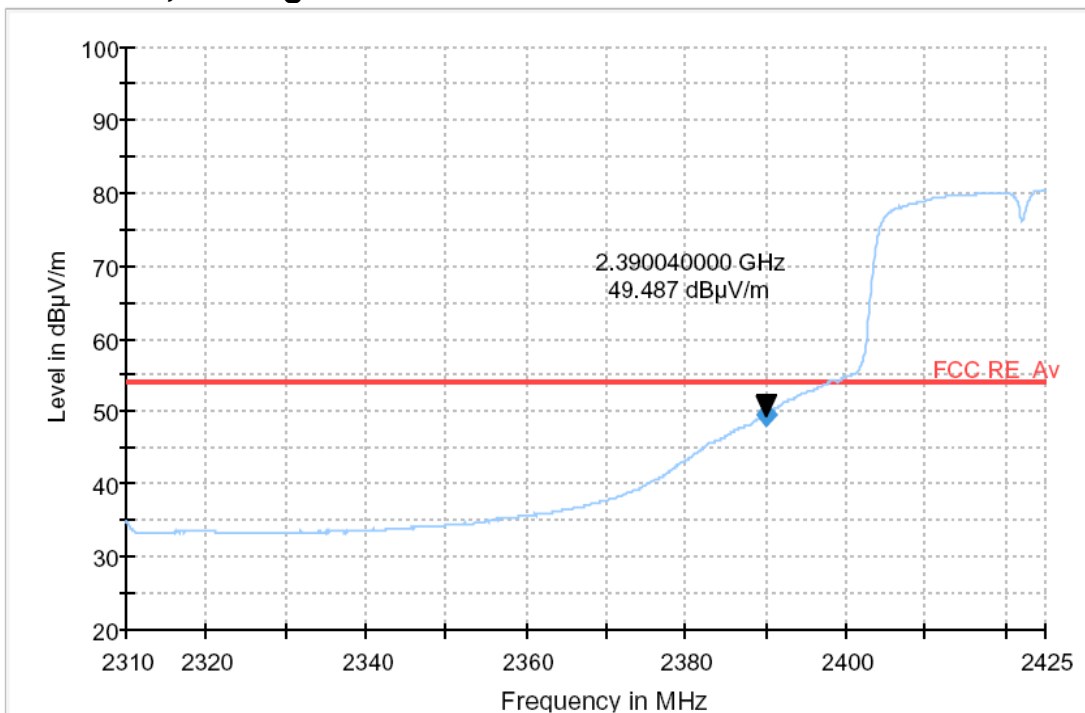

# PLOT OF TEST DATA

## Restricted Band Spurious Emissions, 802.11n(HT40), Lowest channel Vertical, Peak

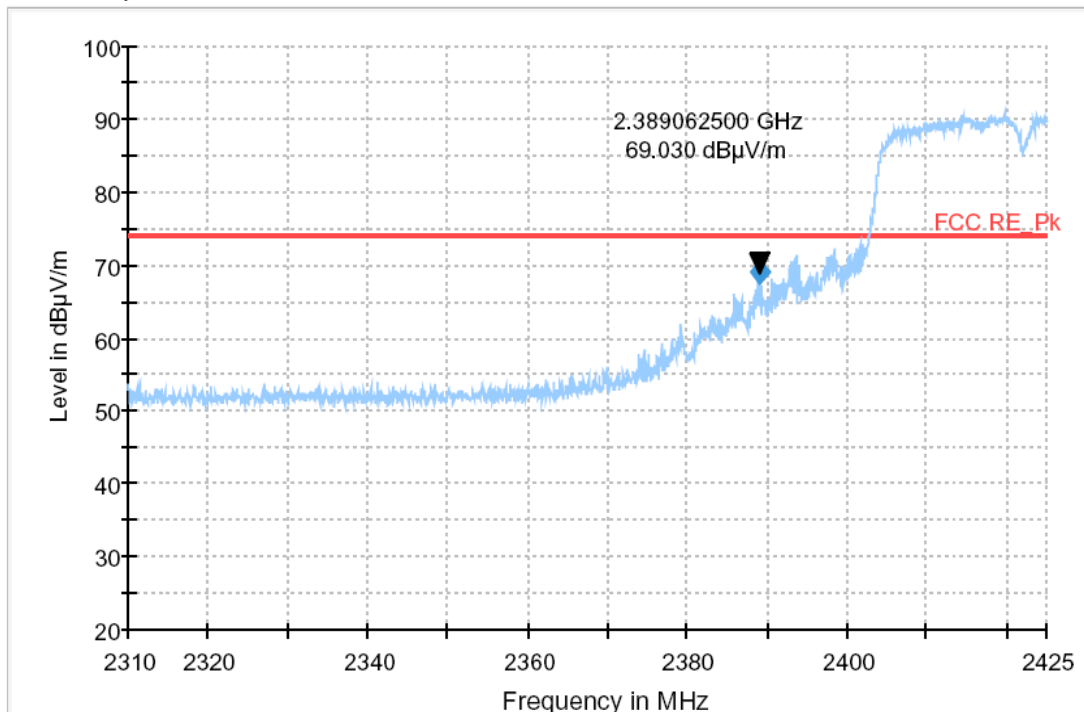

## Restricted Band Spurious Emissions, 802.11n(HT40), Lowest channel Vertical, Average

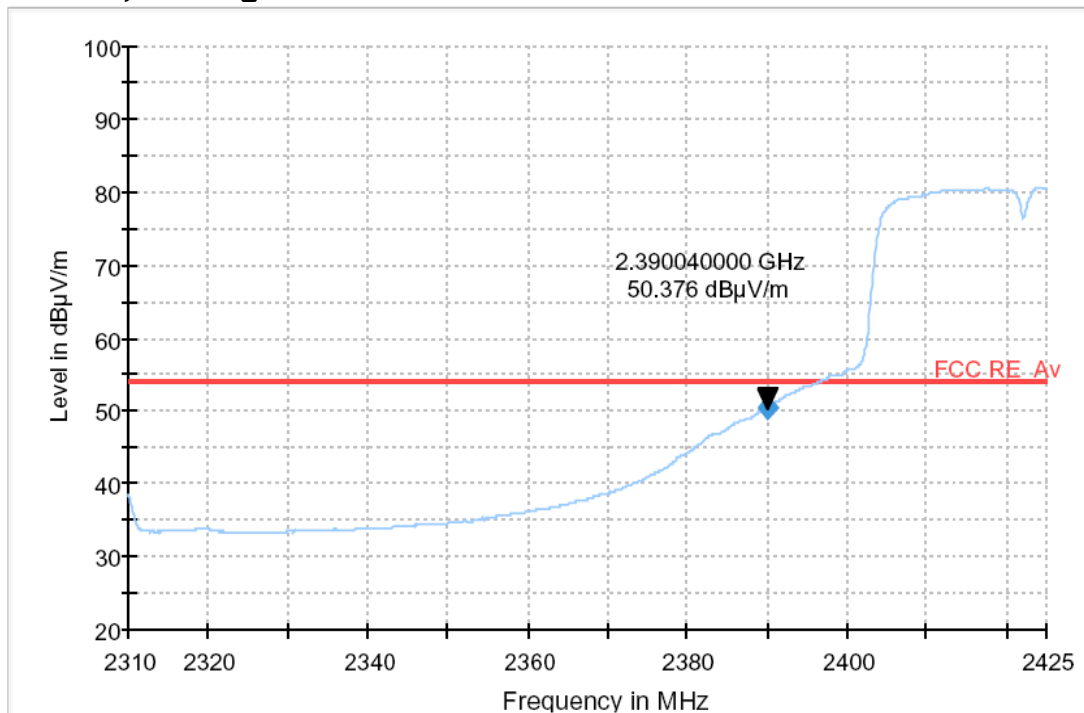

# PLOT OF TEST DATA

## Restricted Band Spurious Emissions, 802.11n(HT40), Highest channel Horizontal, Peak

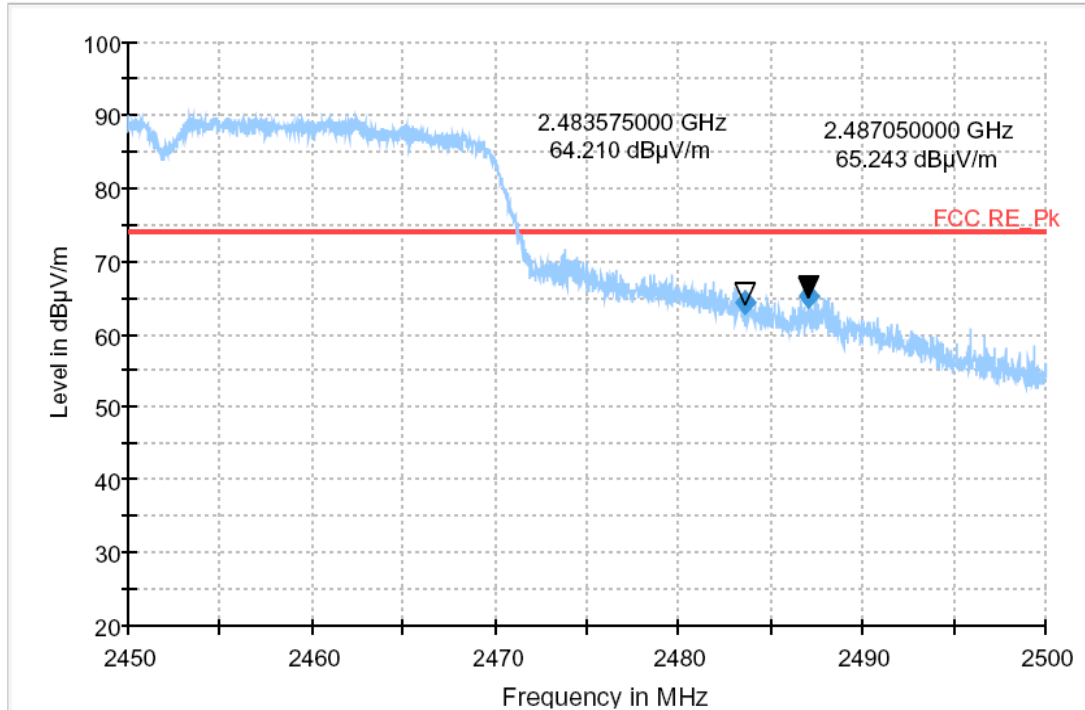

## Restricted Band Spurious Emissions, 802.11n(HT40), Highest channel Horizontal, Average

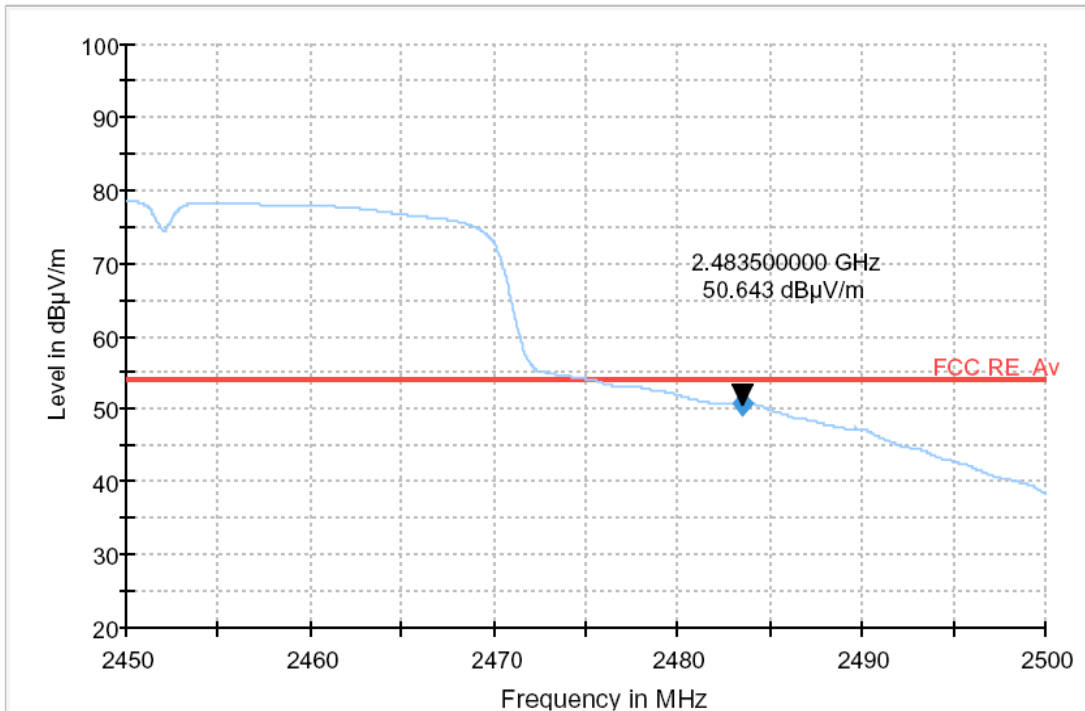

# PLOT OF TEST DATA

## Restricted Band Spurious Emissions, 802.11n(HT40), Highest channel Vertical, Peak

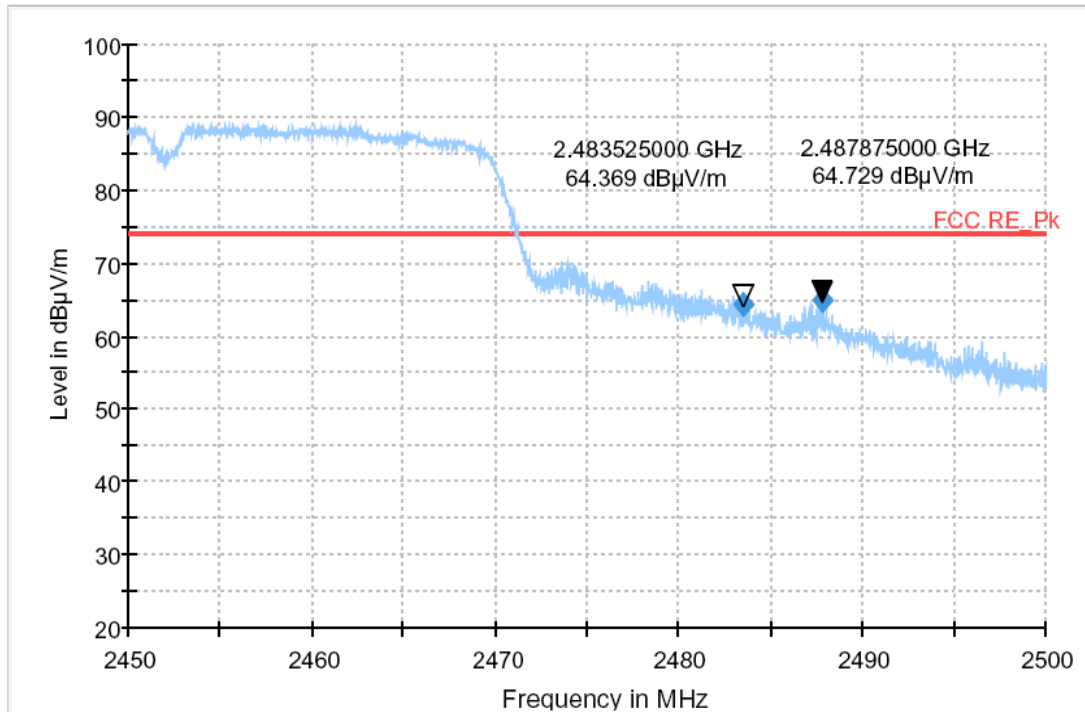

## Restricted Band Spurious Emissions, 802.11n(HT40), Highest channel Vertical, Average

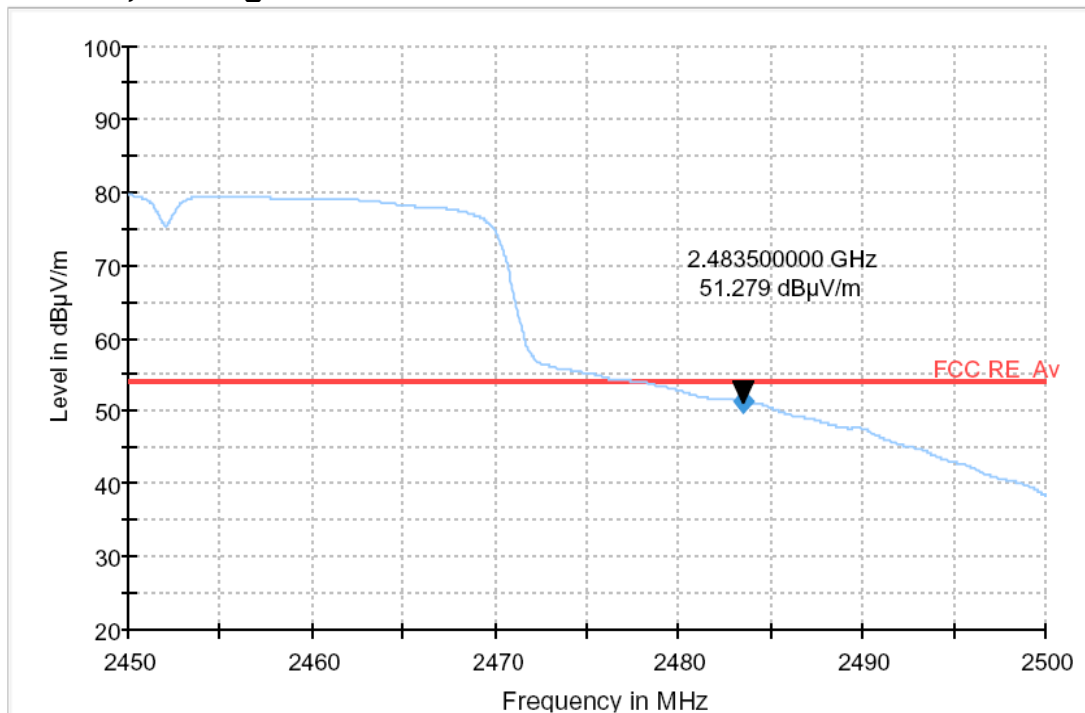

# TEST DATA

## 8.8 Receiver Spurious Emissions

### IC RSS-GEN Clause 6

Frequency (MHz)	Reading (dB $\mu$ V/m)	Pol* (H/V)	AF+CL+Amp (dB)**	Result (dB $\mu$ V/m)	Limit (dB $\mu$ V/m)	Margin (dB)
37.76	48.70	H	-17.60	31.10	40.00	8.90
108.57	47.10	H	-14.20	32.90	43.50	10.60
227.39	48.10	H	-13.30	34.80	46.00	11.20
672.14	43.50	H	-5.30	38.20	46.00	7.80
720.15	43.50	H	-4.90	38.60	46.00	7.40
744.40	40.70	H	-4.60	36.10	46.00	9.90

Radiated Measurements at 3meters

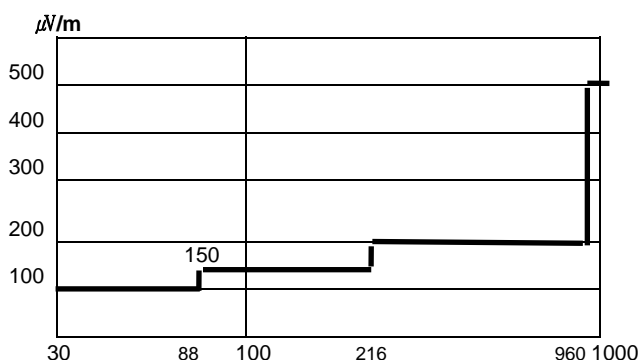

Fig. 5. Limits at 3 meters

**NOTES:**

1. All modes were measured and the worst-case emission was reported.
- 2 The radiated limits are shown on Figure 5. Above 1GHz the limit is 500  $\mu$ V/m.

**NOTES:**

1. \*Pol. H=Horizontal, V=Vertical
2. \*\*AF+CL+Amp. = Antenna Factor + Cable Loss + Amplifier.
3. Measurements using CISPR quasi-peak mode.
4. The radiated emissions testing were made by rotating through three orthogonal axes. The worst date was recorded.
5. The limit is on the IC RSS GEN Clause 6.

## 9. ACCURACY OF MEASUREMENT

The Measurement Uncertainties stated were calculated in accordance with the requirements of measurement uncertainty contained in CISPR 16-4-2 with the confidence level of 95%

### 1. Conducted Uncertainty Calculation

Source of Uncertainty	Xi	Uncertainty of Xi		Coverage factor k	u(Xi) (dB)	Ci	Ci u(Xi) (dB)
		Value (dB)	Probability Distribution				
Receiver reading	<b>RI</b>	± 0.1	normal 1	1.000	0.1	1	0.1
Attenuation AMN-Receiver	<b>LC</b>	± 0.08	normal 2	2.000	0.04	1	0.04
AMN Voltage division factor	<b>LAMN</b>	± 0.8	normal 2	2.000	0.4	1	0.4
Sine wave voltage	<b>dVSW</b>	± 2.00	normal 2	2.000	1.00	1	1.00
Pulse amplitude response	<b>dVPA</b>	± 1.50	rectangular	1.732	0.87	1	0.87
Pulse repetition rate response	<b>dVPR</b>	± 1.50	rectangular	1.732	0.87	1	0.87
Noise floor proximity	<b>dVNF</b>	± 0.00	-	-	0.00	1	0.00
AMN Impedance	<b>dZ</b>	± 1.80	triangular	2.449	0.73	1	0.73
Ⓐ Mismatch	<b>M</b>	+ 0.70	U-Shaped	1.414	0.49	1	0.49
Ⓑ Mismatch	<b>M</b>	- 0.80	U-Shaped	1.414	- 0.56	1	- 0.56
Measurement System Repeatability	<b>RS</b>	0.05	normal 1	1.000	0.05	1	0.05
Remark	Ⓐ: AMN-Receiver Mismatch : + Ⓑ: AMN-Receiver Mismatch : -						
Combined Standard Uncertainty	Normal			± 1.88			
Expended Uncertainty U	Normal (k = 2)			± 3.76			

## 2. Radiation Uncertainty Calculation

Source of Uncertainty	$X_i$	Uncertainty of $X_i$		Coverage factor $k$	$u(X_i)$ (dB)	$C_i$	$C_i u(X_i)$ (dB)
		Value (dB)	Probability Distribution				
Receiver reading	<b>RI</b>	± 0.10	normal 1	1.000	0.10	1	0.10
Sine wave voltage	<b>dVsw</b>	± 2.00	normal 2	2.000	1.00	1	1.00
Pulse amplitude response	<b>dVpa</b>	± 1.50	rectangular	1.732	0.87	1	0.87
Pulse repetition rate response	<b>dVpr</b>	± 1.50	rectangular	1.732	0.87	1	0.87
Noise floor proximity	<b>dVnf</b>	± 0.50	normal 2	2.000	0.25	1	0.25
Antenna Factor Calibration	<b>AF</b>	± 1.50	normal 2	2.000	0.75	1	0.75
Attenuation Antenna-receiver	<b>CL</b>	± 0.52	normal 2	2.000	0.26	1	0.26
Antenna Directivity	<b>AD</b>	± 1.00	rectangular	1.732	0.58	1	0.58
Antenna Factor Height Dependence	<b>AH</b>	± 0.50	rectangular	1.732	0.29	1	0.29
Antenna Phase Centre Variation	<b>AP</b>	± 0.30	rectangular	1.732	0.17	1	0.17
Antenna Factor Frequency Interpolation	<b>AI</b>	± 0.30	rectangular	1.732	0.17	1	0.17
Site Imperfections	<b>SI</b>	± 4.00	triangular	2.449	1.63	1	1.63
Measurement Distance Variation	<b>DV</b>	± 0.10	rectangular	1.732	0.06	1	0.06
Antenna Balance	<b>Dbal</b>	± 0.90	rectangular	1.732	0.52	1	0.52
Cross Polarisation	<b>DCross</b>	± 0.90	rectangular	1.732	0.52	1	0.52
Ⓐ Mismatch	<b>M</b>	+ 0.25	U-Shaped	1.414	0.18	1	0.18
Ⓑ Mismatch	<b>M</b>	- 0.26	U-Shaped	1.414	- 0.18	1	- 0.18
Ⓒ Mismatch	<b>M</b>	+ 0.98	U-Shaped	1.414	0.69	1	0.69
Ⓓ Mismatch	<b>M</b>	- 1.11	U-Shaped	1.414	- 0.79	1	- 0.79
Measurement System Repeatability	<b>RS</b>	0.09	normal 1	1.000	0.09	1	0.09
Remark	Ⓐ: Biconical Antenna-receiver Mismatch : + (< 200 MHz) Ⓑ: Biconical Antenna-receiver Mismatch : - (< 200 MHz) Ⓒ: Log Periodic Antenna-receiver Mismatch : + (≥ 200 MHz) Ⓓ: Log Periodic Antenna-receiver Mismatch : - (≥ 200 MHz)						
Combined Standard Uncertainty	Normal			± 2.63 (< 200 MHz) ± 2.74 (≥ 200 MHz)			
Expanded Uncertainty U	Normal ( $k = 2$ )			± 5.26 (< 200 MHz) ± 5.48 (≥ 200 MHz)			

## 10. TEST EQUIPMENT

No.	Instrument	Manufacturer	Model	Serial No.	Calibration Date	Calibration Interval
1	*Test Receiver	R & S	ESCS 30	833364/020	Mar. 28 2009	1 year
2	*Test Receiver	R & S	ESCS 30	100302	Nov. 11 2009	1 year
3	*Amplifier	HP	8447F	2805A03427	Jul. 20 2009	1 year
4	*Amplifier	Sonoma Instrument	310N	291916	Jul. 22 2009	1 year
5	*Pre Amplifier	HP	8449B	3008A00107	Feb. 12 2009	1 year
6	*Pre Amplifier	HP	8447F	2805A03406	Apr. 09 2009	1 year
7	*Pre Amplifier	Agilent	83051A	3950M00201	Jun. 15 2009	1 year
8	*Spectrum Analyzer	Agilent	E4440A	MY44303257	Jul. 20 2009	1 year
9	*Spectrum Analyzer	Agilent	E4440A	MY44022567	Sep. 04 2009	1 year
10	*Spectrum Analyzer	R & S	FSP40	100361	Sep. 04 2009	1 year
11	*Loop Antenna	EMCO	6502	8911-2436	Jan. 11 2009	2 year
12	*Spectrum Analyzer	R & S	FSP40	100361	Sep. 04 2009	1 year
13	*Power Meter	R & S	NRVS	835360/002	Feb. 12 2009	1 year
14	*Peak Power Sensor	R & S	NRV-Z32	836019/028	Nov. 11 2009	1 year
15	*Biconical Log Anter	ARA	LPB-2520/A	1209	Dec. 08 2008	2 year
16	*Horn Antenna	SCHWARZBECK	BBHA9120D	9120D-508	Dec.11 2008	2 year
17	*Horn Antenna	SCHWARZBECK	BBHA9170	9170223	Jun. 16 2008	2 year
18	*Trilog-Broadband Antenna	SCHWARZBECK	VULB 9168	9168-257	Apr. 21 2008	2 year
19	*Logbicon Antenna	SCHWARZBECK	VULB9166	1067	Oct. 08 2009	2 year
20	*LISN	R & S	ESH3-Z5	833874/006	Nov. 11 2009	1 year
21	*LISN	R & S	ESH2-Z5	100227	Feb. 13 2009	1 year
22	*Position Controller	DAEIL EMC	N/A	N/A	N/A	N/A
23	*Turn Table	DAEIL EMC	N/A	N/A	N/A	N/A
24	*Antenna Mast	DAEIL EMC	N/A	N/A	N/A	N/A
25	*Anechoic Chamber	EM Eng.	N/A	N/A	N/A	N/A
26	*Shielded Room	EM Eng.	N/A	N/A	N/A	N/A
27	*Position Controller	Seo-Young EMC	N/A	N/A	N/A	N/A
28	*Turn Table	Seo-Young EMC	N/A	N/A	N/A	N/A
29	*Antenna Mast	Seo-Young EMC	N/A	N/A	N/A	N/A
30	*Anechoic Chamber	Seo-Young EMC	N/A	N/A	N/A	N/A
31	*Shielded Room	Seo-Young EMC	N/A	N/A	N/A	N/A

\*) Test equipment used during the test