

# TEST REPORT

FCC Test for RF4439d-25A  
Class II Permissive Change

**APPLICANT**  
SAMSUNG Electronics Co., Ltd.

**REPORT NO.**  
HCT-RF-2110-FC021-R1

**DATE OF ISSUE**  
December 6, 2021

**Tested by**  
Kwang Il Yoon

**Technical Manager**  
Jong Seok Lee

**HCT CO., LTD.**  
*Bongjai Huh*  
BongJai Huh / CEO



**HCT Co., Ltd.**

74, Seoicheon-ro 578beon-gil, Majang-myeon, Icheon-si, Gyeonggi-do, 17383 KOREA  
Tel. +82 31 634 6300 Fax. +82 31 645 6401

**TEST  
REPORT**  
FCC Test for  
RF4439d-25A

**REPORT NO.**  
HCT-RF-2110-FC021-R1

**DATE OF ISSUE**  
December 06, 2021

**Additional Model**  
-

|                        |  |
|------------------------|--|
| <b>Applicant</b>       | <b>SAMSUNG Electronics Co., Ltd.</b><br>129, Samsung-ro, Yeongtong-gu, Suwon-si, Gyeonggi-do, 16677, Rep. of Korea |
| <b>EUT Type</b>        | RRU(RF4439d)   |
| <b>Model Name</b>      | RF4439d-25A  |
| <b>FCC ID</b>          | A3LRF4439D-25A   |
| <b>Date of Test</b>    | October 18, 2021 ~ October 27, 2021  |
| <b>FCC Rule Parts:</b> | CFR 47 Part 2, Part 24   |

The result shown in this test report refer only to the sample(s) tested unless otherwise stated.  
This test results were applied only to the test methods required by the standard.

## REVISION HISTORY

The revision history for this test report is shown in table.

| Revision No. | Date of Issue     | Description   |
|--------------|-------------------|---|
| 0            | October 29, 2021  | Initial Release   |
| 1            | December 06, 2021 | We added a note on page 8.<br>We added information on page 5. |

The measurements shown in this report were made in accordance with the procedures indicated, and the emissions from this equipment were found to be within the limits applicable. I assume full responsibility for the accuracy and completeness of these measurements, and for the qualifications of all persons taking them. It is further stated that upon the basis of the measurements made, the equipment tested is capable of operation in accordance with the requirements of the FCC Rules under normal use and maintenance.

If this report is required to confirmation of authenticity, please contact to [www.hct.co.kr](http://www.hct.co.kr)

## CONTENTS

|  |     |
|--|-----|
| 1. GENERAL INFORMATION                       | 5   |
| 1.1. APPLICANT INFORMATION                   | 5   |
| 1.2. PRODUCT INFORMATION                     | 5   |
| 1.3. TEST INFORMATION                        | 5   |
| 2. FACILITIES AND ACCREDITATIONS             | 6   |
| 2.1. FACILITIES                              | 6   |
| 2.2. EQUIPMENT                               | 6   |
| 3. TEST SPECIFICATIONS                       | 7   |
| 3.1. STANDARDS                               | 7   |
| 3.2. ADDITIONAL DESCRIPTIONS ABOUT TEST      | 8   |
| 3.3. MAXIMUM MEASUREMENT UNCERTAINTY         | 13  |
| 3.4. STANDARDS ENVIRONMENTAL TEST CONDITIONS | 13  |
| 3.5. TEST DIAGRAMS                           | 14  |
| 4. TEST EQUIPMENTS                           | 16  |
| 5. TEST RESULT                               | 17  |
| 5.1. RF OUTPUT POWER and PSD                 | 17  |
| 5.2. PAPR                                    | 40  |
| 5.3. OCCUPIED BANDWIDTH                      | 50  |
| 5.4. OUT-OF-BAND UNWANTED EMISSIONS          | 61  |
| 5.5. SPURIOUS UNWANTED EMISSIONS             | 71  |
| 5.6. RADIATED EMISSIONS                      | 96  |
| 5.7. FREQUENCY STABILITY                     | 99  |
| 6. Annex B_EUT AND TEST SETUP PHOTO          | 103 |

## 1. GENERAL INFORMATION

### 1.1. APPLICANT INFORMATION

|                 |   |
|-----------------|---|
| Company Name    | Samsung Electronics Co., Ltd.   |
| Company Address | 129, Samsung-ro, Yeongtong-gu, Suwon-si, Gyeonggi-do, 16677,<br>Rep. of Korea |

### 1.2. PRODUCT INFORMATION

|                           |                                |           |                     |                  |                         |                  |
|---------------------------|--------------------------------|-----------|---------------------|------------------|-------------------------|------------------|
| EUT Type                  | RRU(RF4439d)                   |           |                     |                  |                         |                  |
| EUT Serial Number         | S617703329                     |           |                     |                  |                         |                  |
| Power Supply              | -48 VDC                        |           |                     |                  |                         |                  |
| Output Power              | Band                           | Carrier   | Bandwidth           |                  | Power                   |                  |
|                           | B2 DSS                         | 1         | 15 MHz              |                  | 40 W/path, Total: 160 W |                  |
| Frequency Range           | Band 2 : 1 930 MHz ~ 1 990 MHz |           |                     |                  |                         |                  |
| Emission Designator       | Mode<br>(LTE : NR Ratio)       | Bandwidth | Emission Designator |                  |                         |                  |
|                           |                                |           | QPSK<br>(G7D)       | Conducted<br>(W) | 16/64/256 QAM<br>(W7D)  | Conducted<br>(W) |
|                           | B2 DSS 9 : 1                   | 15 MHz    | 14M0G7D             | 151.13           | 14M1W7D                 | 151.93           |
|                           | B2 DSS 5 : 5                   | 15 MHz    | 14M1G7D             | 145.68           | 14M2W7D                 | 146.60           |
|                           | B2 DSS 2 : 8                   | 15 MHz    | 14M2G7D             | 142.48           | 14M2W7D                 | 143.78           |
|                           | LTE B2                         | 5 MHz     | 4M51G7D             | 18.31            | -                       | -                |
|                           | LTE B2                         | 10 MHz    | -                   | -                | 8M99W7D                 | 37.43            |
|                           | LTE B2                         | 15 MHz    | -                   | -                | 13M5W7D                 | 36.55            |
| LTE B2                    | 20 MHz                         | -         | -                   | 18M0W7D          | 37.64                   |                  |
| Modulation Type           | QPSK, 16QAM, 64QAM, 256QAM     |           |                     |                  |                         |                  |
| SCS (Sub-carrier Spacing) | LTE: 15 kHz, DSS: 15 kHz       |           |                     |                  |                         |                  |

### 1.3. TEST INFORMATION

|                       |  |
|-----------------------|--|
| FCC Rule Parts        | CFR 47 Part 2, Part 24   |
| Measurement standards | ANSI C63.26-2015, KDB 662911 D01 v02r01, KDB 971168 D01 v03r01   |
| Place of Test         | HCT CO., LTD.<br>74, Seoicheon-ro 578beon-gil, Majang-myeon, Icheon-si, Gyeonggi-do,<br>17383, Rep. of KOREA |

## 2. FACILITIES AND ACCREDITATIONS

### 2.1. FACILITIES

The SAC(Semi-Anechoic Chamber) and conducted measurement facility used to collect the radiated data are located at the 74, Seoicheon-ro 578beon-gil, Majang-myeon, Icheon-si, Gyeonggi-do, 17383, Rep. of KOREA.

The site is constructed in conformance with the requirements of ANSI C63.4. (Version :2014) and CISPR Publication 22.

Detailed description of test facility was submitted to the Commission and accepted dated April 02, 2018 (Registration Number: KR0032).

### 2.2. EQUIPMENT

Radiated emissions are measured with one or more of the following types of Linearly polarized antennas: tuned dipole, bi-conical, log periodic, bi-log, and/or ridged waveguide, horn. Spectrum analyzers with pre-selectors and quasi-peak detectors are used to perform radiated measurements.

Calibrated wideband preamplifiers, coaxial cables, and coaxial attenuators are also used for making measurements.

All receiving equipment conforms to CISPR Publication 16-1, "Radio Interference Measuring Apparatus and Measurement Methods."

### 3. TEST SPECIFICATIONS

#### 3.1. STANDARDS

The following tests were conducted on a sample of the equipment for the purpose of demonstrating compliance with FCC Part 2, Part 24

| Description                    | Reference          | Results   |
|--------------------------------|--------------------|-----------|
| RF Output Power                | § 2.1046, § 24.232 | Compliant |
| PAPR                           | § 24.232(d)        | Compliant |
| Occupied Bandwidth             | § 2.1049           | Compliant |
| Out-of-band Unwanted Emissions | § 2.1051, § 24.238 | Compliant |
| Spurious Unwanted Emissions    |                    | Compliant |
| Radiated Emissions             | § 2.1053, § 24.238 | Compliant |
| Frequency Stability            | § 2.1055, § 24.235 | Compliant |

### 3.2. ADDITIONAL DESCRIPTIONS ABOUT TEST

- The EUT was operated in a manner representative of the typical usage of the equipment.
- During all testing, system components were manipulated within the confines of typical usage to maximize each emission.
- All LTE and 5G NR modulation types (QPSK, 16QAM, 64QAM, 256QAM) within the DSS operating mode and LTE modulation types (QPSK, 16QAM, 64QAM, 256QAM) have been tested.
- All mode of operation, supporting bandwidth and frequencies were investigated. The test plots shown in the following sections represent the worst case emissions.
- The measurement has performed for each LTE and DSS Carrier in the mode of full resource Block size as worst case to transmit maximum output power condition.
- The dummy loads were connected to the RF output ports for radiated spurious emission testing.
- This device supports Dynamic Spectrum Sharing(DSS) on a 15 MHz channel with LTE:5G NR ratios of between 9:1 and 2:8. Preliminary testing across various different ratios indicated that the ratio had no significant affect on the emissions from the device. This report includes the data for LTE:5G NR Ratio of 9:1, 5:5 and 2:8 including worst case ratio to be representative of all possible LTE:5G NR ratios.
- The device was operating at 100% duty cycle
- The tests results in plots are already including the actual value of loss for the attenuator and cable combination.  
Please check correction factors below table.
- ANT 0/1/2/3 in this report are indicating the test result for each antennas in each frequency band repectively like below.

| ANT  | Antenna Number and Band |            |
|------|-------------------------|------------|
| ANT0 | Ant 1 (B66)             | Ant 5 (B2) |
| ANT1 | Ant 2 (B66)             | Ant 6 (B2) |
| ANT2 | Ant 3 (B66)             | Ant 7 (B2) |
| ANT3 | Ant 4 (B66)             | Ant 8 (B2) |



**ANTO****Correction factor table**

| Frequency (MHz) | Factor (dB) | Frequency (MHz) | Factor (dB) |
|-----------------|-------------|-----------------|-------------|
| 500             | 30.276      | 4 000           | 33.541      |
| 600             | 30.425      | 5 000           | 35.167      |
| 700             | 30.634      | 6 000           | 34.680      |
| 800             | 30.742      | 7 000           | 36.106      |
| 900             | 30.877      | 8 000           | 36.286      |
| 1 000           | 30.964      | 9 000           | 37.440      |
| 1 100           | 31.088      | 10 000          | 38.573      |
| 1 200           | 31.207      | 11 000          | 39.577      |
| 1 300           | 31.282      | 12 000          | 40.360      |
| 1 400           | 31.394      | 13 000          | 41.343      |
| 1 500           | 31.429      | 14 000          | 41.279      |
| 1 600           | 31.643      | 15 000          | 41.353      |
| 1 700           | 31.646      | 16 000          | 42.032      |
| 1 800           | 31.752      | 17 000          | 42.408      |
| 1 900           | 32.104      | 18 000          | 42.739      |
| 2 000           | 32.134      | 19 000          | 42.530      |
| 2 100           | 32.052      | 20 000          | 44.425      |
| 2 200           | 32.340      | 21 000          | 44.517      |
| 2 300           | 32.501      | 22 000          | 44.144      |
| 2 400           | 32.370      | 23 000          | 44.497      |
| 2 500           | 32.355      | 24 000          | 46.247      |
| 2 600           | 32.517      | 25 000          | 49.764      |
| 2 700           | 32.656      | 26 000          | 46.257      |
| 2 800           | 32.532      | -               | -           |
| 2 900           | 32.645      | -               | -           |
| 3 000           | 32.888      | -               | -           |

**ANT1****Correction factor table**

| Frequency (MHz) | Factor (dB) | Frequency (MHz) | Factor (dB) |
|-----------------|-------------|-----------------|-------------|
| 500             | 30.151      | 4 000           | 33.210      |
| 600             | 30.334      | 5 000           | 34.600      |
| 700             | 30.539      | 6 000           | 34.483      |
| 800             | 30.604      | 7 000           | 35.377      |
| 900             | 30.754      | 8 000           | 36.103      |
| 1 000           | 30.884      | 9 000           | 36.902      |
| 1 100           | 30.986      | 10 000          | 38.260      |
| 1 200           | 31.133      | 11 000          | 39.082      |
| 1 300           | 31.234      | 12 000          | 40.808      |
| 1 400           | 31.300      | 13 000          | 42.672      |
| 1 500           | 31.375      | 14 000          | 43.425      |
| 1 600           | 31.537      | 15 000          | 43.615      |
| 1 700           | 31.554      | 16 000          | 44.577      |
| 1 800           | 31.687      | 17 000          | 43.882      |
| 1 900           | 31.840      | 18 000          | 44.061      |
| 2 000           | 31.943      | 19 000          | 43.562      |
| 2 100           | 31.953      | 20 000          | 44.994      |
| 2 200           | 32.127      | 21 000          | 45.649      |
| 2 300           | 32.177      | 22 000          | 45.513      |
| 2 400           | 32.190      | 23 000          | 46.111      |
| 2 500           | 32.242      | 24 000          | 46.237      |
| 2 600           | 32.354      | 25 000          | 46.735      |
| 2 700           | 32.406      | 26 000          | 49.801      |
| 2 800           | 32.444      | -               | -           |
| 2 900           | 32.543      | -               | -           |
| 3 000           | 32.674      | -               | -           |

**ANT2****Correction factor table**

| Frequency (MHz) | Factor (dB) | Frequency (MHz) | Factor (dB) |
|-----------------|-------------|-----------------|-------------|
| 500             | 30.256      | 4 000           | 33.349      |
| 600             | 30.442      | 5 000           | 34.613      |
| 700             | 30.625      | 6 000           | 34.584      |
| 800             | 30.700      | 7 000           | 35.682      |
| 900             | 30.866      | 8 000           | 36.128      |
| 1 000           | 30.962      | 9 000           | 36.984      |
| 1 100           | 31.061      | 10 000          | 38.233      |
| 1 200           | 31.190      | 11 000          | 39.493      |
| 1 300           | 31.291      | 12 000          | 40.408      |
| 1 400           | 31.389      | 13 000          | 41.817      |
| 1 500           | 31.393      | 14 000          | 40.749      |
| 1 600           | 31.585      | 15 000          | 40.529      |
| 1 700           | 31.607      | 16 000          | 41.728      |
| 1 800           | 31.736      | 17 000          | 41.104      |
| 1 900           | 31.920      | 18 000          | 42.201      |
| 2 000           | 32.043      | 19 000          | 41.170      |
| 2 100           | 32.036      | 20 000          | 43.137      |
| 2 200           | 32.140      | 21 000          | 43.402      |
| 2 300           | 32.201      | 22 000          | 45.137      |
| 2 400           | 32.220      | 23 000          | 43.489      |
| 2 500           | 32.239      | 24 000          | 46.028      |
| 2 600           | 32.362      | 25 000          | 47.221      |
| 2 700           | 32.483      | 26 000          | 44.850      |
| 2 800           | 32.529      | -               | -           |
| 2 900           | 32.567      | -               | -           |
| 3 000           | 32.712      | -               | -           |

**ANT3****Correction factor table**

| Frequency (MHz) | Factor (dB) | Frequency (MHz) | Factor (dB) |
|-----------------|-------------|-----------------|-------------|
| 500             | 30.342      | 4 000           | 33.430      |
| 600             | 30.513      | 5 000           | 34.793      |
| 700             | 30.719      | 6 000           | 34.578      |
| 800             | 30.799      | 7 000           | 35.526      |
| 900             | 30.998      | 8 000           | 36.167      |
| 1 000           | 31.144      | 9 000           | 37.037      |
| 1 100           | 31.427      | 10 000          | 38.161      |
| 1 200           | 32.569      | 11 000          | 39.337      |
| 1 300           | 33.894      | 12 000          | 40.312      |
| 1 400           | 31.703      | 13 000          | 41.828      |
| 1 500           | 31.595      | 14 000          | 42.621      |
| 1 600           | 31.701      | 15 000          | 41.702      |
| 1 700           | 31.710      | 16 000          | 42.338      |
| 1 800           | 31.800      | 17 000          | 42.170      |
| 1 900           | 31.971      | 18 000          | 42.809      |
| 2 000           | 32.146      | 19 000          | 42.366      |
| 2 100           | 32.116      | 20 000          | 44.353      |
| 2 200           | 32.231      | 21 000          | 45.127      |
| 2 300           | 32.358      | 22 000          | 45.994      |
| 2 400           | 32.376      | 23 000          | 46.962      |
| 2 500           | 32.348      | 24 000          | 48.471      |
| 2 600           | 32.565      | 25 000          | 49.924      |
| 2 700           | 32.593      | 26 000          | 47.484      |
| 2 800           | 32.575      | -               | -           |
| 2 900           | 32.732      | -               | -           |
| 3 000           | 32.879      | -               | -           |

### 3.3. MAXIMUM MEASUREMENT UNCERTAINTY

| Description          | Condition       | Uncertainty |
|----------------------|-----------------|-------------|
| Radiated Disturbance | 9 kHz ~ 30 MHz  | ± 3.40 dB   |
|                      | 30 MHz ~ 1 GHz  | ± 4.80 dB   |
|                      | 1 GHz ~ 18 GHz  | ± 5.70 dB   |
|                      | 18 GHz ~ 40 GHz | ± 5.05 dB   |

Coverage factor  $k=2$ , Confidence levels of 95 %

### 3.4. STANDARDS ENVIRONMENTAL TEST CONDITIONS

|                    |                        |
|--------------------|------------------------|
| Temperature :      | +15 °C to +35 °C       |
| Relative humidity: | 30 % to 60 %           |
| Air pressure       | 860 mbar to 1 060 mbar |

## 3.5. TEST DIAGRAMS

## Conducted Test

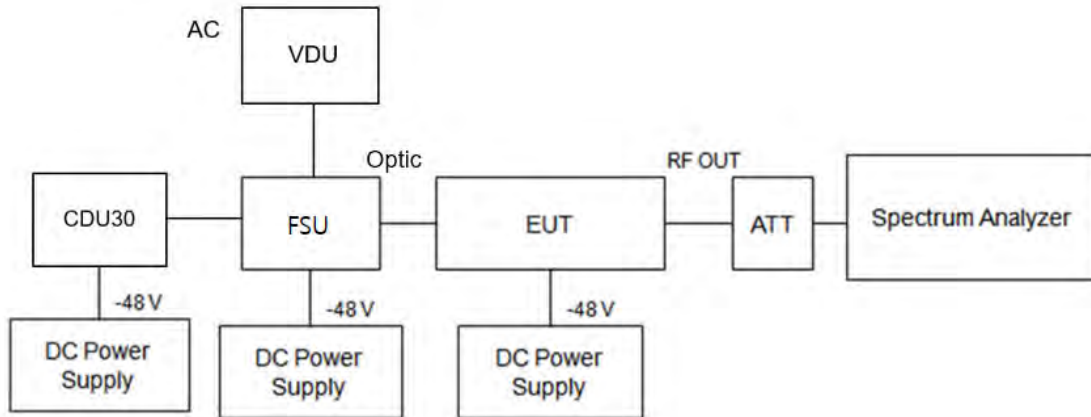

## Radiated Test

30 MHz ~ 1 GHz

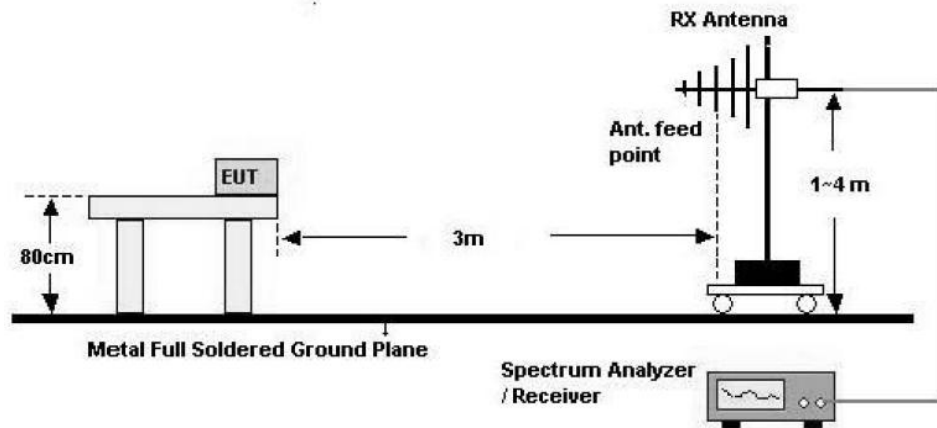

Above 1 GHz

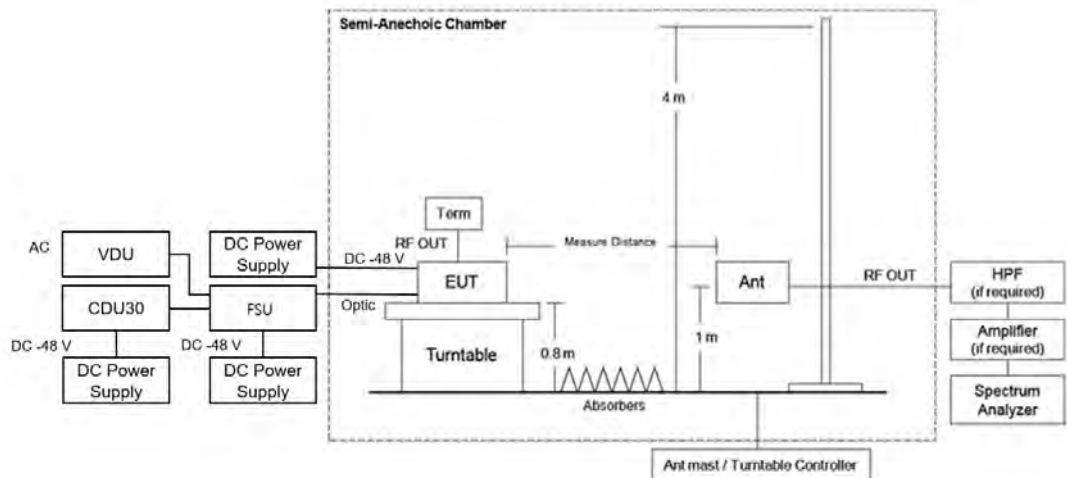

※ EUT position is adopted by placement of floor-standing refer to section 5.5.2.3.2 of ANSI C63.26-2015

## Frequency Stability

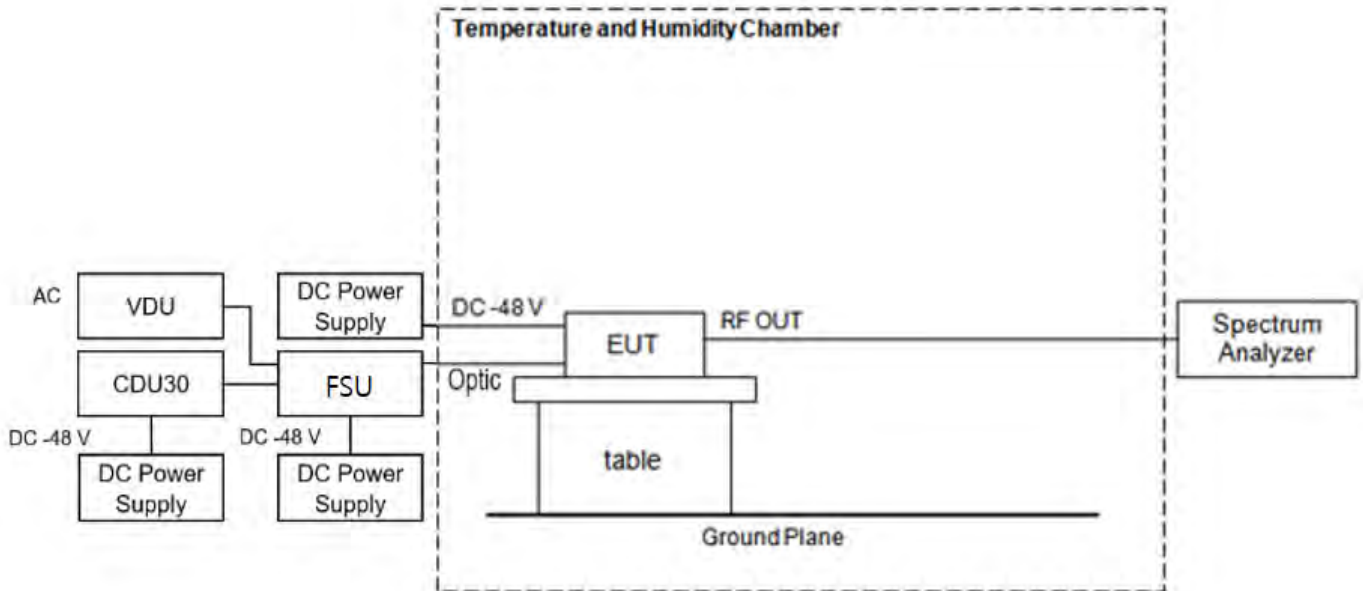

**Note:** All modulations(QPSK, 16QAM, 64QAM, 256QAM) were investigated and the worst case configuration channel results are reported.

#### 4. TEST EQUIPMENTS

| Equipment                             | Model                       | Manufacturer           | Serial No.             | Due to Calibration | Calibration Interval |
|---------------------------------------|-----------------------------|------------------------|------------------------|--------------------|----------------------|
| MXA Signal Analyzer                   | N9020A                      | Agilent                | MY46471250             | 2022-08-11         | Annual               |
| PXA Signal Analyzer                   | N9030A                      | Keysight               | US51350313             | 2022-03-30         | Annual               |
| 30 dB Attenuator                      | WA93-30-33                  | Weinschel Associates   | 0137                   | 2022-03-30         | Annual               |
| 30 dB Attenuator                      | WA93-30-33                  | Weinschel Associates   | 0190                   | 2022-03-30         | Annual               |
| 30 dB Attenuator                      | WA93-30-33                  | Weinschel Associates   | 0155                   | 2022-04-01         | Annual               |
| 30 dB Attenuator                      | WA93-30-33                  | Weinschel Associates   | 0149                   | 2022-04-01         | Annual               |
| DC Power Supply                       | 6674A                       | Hewlett Packard        | 3637A01843             | 2022-06-30         | Annual               |
| DC Power Supply                       | PWR1600L                    | KIKUSUI                | RL002213               | 2022-09-29         | Annual               |
| Temperature and Humidity Chamber      | NY-THR18750                 | NANGYEUL CO., LTD.     | NY-200912201A          | 2022-01-14         | Annual               |
| Amp & Filter Bank Switch Controller   | FBSM-01B                    | TNM system             | TM20090002             | N/A                | N/A                  |
| Controller(Antenna mast & Turn Table) | CO3000                      | Innco systems          | CO3000/1251/48920320/P | N/A                | N/A                  |
| Antenna Position Tower                | MA4640/800-XP-ET            | Innco systems          | N/A                    | N/A                | N/A                  |
| Turn Table                            | DS2000-S                    | Innco systems          | N/A                    | N/A                | N/A                  |
| Turn Table                            | Turn Table                  | Ets                    | N/A                    | N/A                | N/A                  |
| Loop Antenna                          | FMZB 1513                   | Schwarzbeck            | 1513-333               | 2022-03-19         | Biennial             |
| Hybrid Antenna                        | VULB 9168                   | Schwarzbeck            | 01039                  | 2022-08-02         | Biennial             |
| Horn Antenna                          | BBHA 9120D                  | Schwarzbeck            | 02296                  | 2022-06-28         | Biennial             |
| Horn Antenna(15 GHz ~ 40 GHz)         | BBHA9170                    | Schwarzbeck            | BBHA9170342            | 2022-10-13         | Biennial             |
| PXA Signal Analyzer                   | N9030B                      | Keysight               | MY55480167             | 2022-06-02         | Annual               |
| HPF(3 ~ 18 GHz) + LNA(0.1 ~ 18 GHz)   | FBSR-04C                    | TNM system             | N/A                    | 2022-09-16         | Annual               |
| Low Noise Amplifier                   | LLAU1183540Q                | LTC Microwave          | 100                    | 2022-09-16         | Annual               |
| High Pass Filter                      | WHKX12-2805-3000-18000-40SS | Wainwright Instruments | 45                     | 2022-09-16         | Annual               |
| Power Amplifier                       | CBL18265035                 | CERNEX                 | 22966                  | 2021-12-04         | Annual               |
| Power Amplifier                       | CBL26405040                 | CERNEX                 | 25956                  | 2022-03-23         | Annual               |

**Note:**

1. Equipment listed above that calibrated during the testing period was set for test after the calibration.
2. Equipment listed above that has a calibration due date during the testing period, the testing is completed before equipment expiration date, or will be tested after the calibration is completed.



## 5. TEST RESULT

### 5.1. RF OUTPUT POWER and PSD

#### Test Requirements:

##### § 2.1046 Measurements required: RF power output.

- (a) For transmitters other than single sideband, independent sideband and controlled carrier radiotelephone, power output shall be measured at the RF output terminals when the transmitter is adjusted in accordance with the tune-up procedure to give the values of current and voltage on the circuit elements specified in § 2.1033(c)(8). The electrical characteristics of the radio frequency load attached to the output terminals when this test is made shall be stated.
- (b) For single sideband, independent sideband, and single channel, controlled carrier radiotelephone transmitters the procedure specified in paragraph (a) of this section shall be employed and, in addition, the transmitter shall be modulated during the test as specified and applicable in § 2.1046 (b) (1-5). In all tests, the input level of the modulating signal shall be such as to develop rated peak envelope power or carrier power, as appropriate, for the transmitter.
- (c) For measurements conducted pursuant to paragraphs (a) and (b) of this section, all calculations and methods used by the applicant for determining carrier power or peak envelope power, as appropriate, on the basis of measured power in the radio frequency load attached to the transmitter output terminals shall be shown. Under the test conditions specified, no components of the emission spectrum shall exceed the limits specified in the applicable rule parts as necessary for meeting occupied bandwidth or emission limitations.

##### § 24.232 Power and antenna height limits.

- (a) (1) Base stations with an emission bandwidth of 1 MHz or less are limited to 1640 watts equivalent isotropically radiated power (EIRP) with an antenna height up to 300 meters HAAT, except as described in paragraph (b) below.
- (2) Base stations with an emission bandwidth greater than 1 MHz are limited to 1640 watts/MHz equivalent isotropically radiated power (EIRP) with an antenna height up to 300 meters HAAT, except as described in paragraph (b) below.
- (3) Base station antenna heights may exceed 300 meters HAAT with a corresponding reduction in power; see Tables 1 and 2 of this section.
- (4) The service area boundary limit and microwave protection criteria specified in § § 24.236 and 24.237 apply.

Table 1—Reduced Power for Base Station Antenna Heights Over 300 Meters, With Emission Bandwidth of 1 MHz or Less

| HAAT in meters | Maximum EIRP<br>watts |
|----------------|-----------------------|
| ≤300           | 1640                  |
| ≤500           | 1070                  |
| ≤1000          | 490                   |
| ≤1500          | 270                   |
| ≤2000          | 160                   |

Table 2—Reduced Power for Base Station Antenna Heights Over 300 Meters, With Emission Bandwidth Greater Than 1 MHz

| HAAT in meters | Maximum EIRP<br>watts/MHz |
|----------------|---------------------------|
| ≤300           | 1640                      |
| ≤500           | 1070                      |
| ≤1000          | 490                       |
| ≤1500          | 270                       |
| ≤2000          | 160                       |

- (b) (1) Base stations that are located in counties with population densities of 100 persons or fewer per square mile, based upon the most recently available population statistics from the Bureau of the Census, with an emission bandwidth of 1 MHz or less are limited to 3280 watts equivalent isotropically radiated power (EIRP) with an antenna height up to 300 meters HAAT.
- (2) Base stations that are located in counties with population densities of 100 persons or fewer per square mile, based upon the most recently available population statistics from the Bureau of the Census, with an emission bandwidth greater than 1 MHz are limited to 3280 watts/MHz equivalent isotropically radiated power (EIRP) with an antenna height up to 300 meters HAAT.
- (3) Base station antenna heights may exceed 300 meters HAAT with a corresponding reduction in power; see Tables 3 and 4 of this section.
- (4) The service area boundary limit and microwave protection criteria specified in § § 24.236 and 24.237 apply.
- (5) Operation under this paragraph (b) at power limits greater than permitted under paragraph (a) of this section must be coordinated in advance with all broadband PCS licensees authorized to operate on adjacent frequency blocks within 120 kilometers (75 miles) of the base station and is limited to base stations located more than 120 kilometers (75 miles) from the Canadian border and more than 75 kilometers (45 miles) from the Mexican border.

Table 3—Reduced Power for Base Station Antenna Heights Over 300 Meters, With Emission Bandwidth of 1 MHz or Less

| HAAT in meters | Maximum EIRP<br>watts |
|----------------|-----------------------|
| ≤300           | 3280                  |
| ≤500           | 2140                  |
| ≤1000          | 980                   |
| ≤1500          | 540                   |
| ≤2000          | 320                   |

Table 4—Reduced Power for Base Station Antenna Heights Over 300 Meters, With Emission Bandwidth Greater Than 1 MHz

| HAAT in meters | Maximum EIRP<br>watts/MHz |
|----------------|---------------------------|
| ≤300           | 3280                      |
| ≤500           | 2140                      |
| ≤1000          | 980                       |
| ≤1500          | 540                       |
| ≤2000          | 320                       |

- (c) Mobile and portable stations are limited to 2 watts EIRP and the equipment must employ a means for limiting power to the minimum necessary for successful communications.
- (d) Power measurements for transmissions by stations authorized under this section may be made either in accordance with a Commission-approved average power technique or in compliance with paragraph (e) of this section. In both instances, equipment employed must be authorized in accordance with the provisions of § 24.51. In measuring transmissions in this band using an average power technique, the peak-to-average ratio (PAR) of the transmission may not exceed 13 dB.
- (e) Peak transmit power must be measured over any interval of continuous transmission using instrumentation calibrated in terms of an rms-equivalent voltage. The measurement results shall be properly adjusted for any instrument limitations, such as detector response times, limited resolution bandwidth capability when compared to the emission bandwidth, sensitivity, etc., so as to obtain a true peak measurement for the emission in question over the full bandwidth of the channel.

**Test Procedures:**

The measurement is performed in accordance with Section 5.2.4.4.1 of ANSI C63.26.

The EUT is considered to transmit continuously if it can be configured to transmit at a burst duty cycle of greater than or equal to 98% throughout the duration of the measurement. If this condition can be achieved, then the following procedure can be used to measure the average output power of the EUT.

- a) Set span to 2 × to 3 × the OBW.
- b) Set RBW = 1% to 5% of the OBW.
- c) Set VBW ≥ 3 × RBW.
- d) Set number of measurement points in sweep ≥ 2 × span / RBW.
- e) Sweep time:
  - 1) Set = auto-couple, or
  - 2) Set ≥ [10 × (number of points in sweep) × (transmission period)] for single sweep (automation-compatible) measurement. Transmission period is the on and off time of the transmitter.
- f) Detector = power averaging (rms).
- g) If the EUT can be configured to transmit continuously, then set the trigger to free run.
- h) If the EUT cannot be configured to transmit continuously, then use a sweep trigger with the level set to enable triggering only on full power bursts and configure the EUT to transmit at full power for the entire duration of each sweep. Verify that the sweep time is less than or equal to the transmission burst duration. Time gating can also be used under similar

- constraints (i.e., configured such that measurement data is collected only during active full-power transmissions).
- i) Trace average at least 100 traces in power averaging (rms) mode if sweep is set to auto-couple. To accurately determine the average power over multiple symbols, it can be necessary to increase the number of traces to be averaged above 100 or, if using a manually configured sweep time, increase the sweep time.
  - j) Compute the power by integrating the spectrum across the OBW of the signal using the instrument's band or channel power measurement function, with the band/channel limits set equal to the OBW band edges. If the instrument does not have a band or channel power function, then sum the spectrum levels (in linear power units) at intervals equal to the RBW extending across the entire OBW of the spectrum.

The measurement is performed in accordance with Section 5.2.4.5 of ANSI C63.26.

Some regulatory requirements specify the RF output power limits in terms of maximum or average PSD, (i.e., the output power or unwanted emissions power limits are defined within a specified reference bandwidth).

When average PSD limits are specified, the same fundamental measurement condition applies as previously discussed (i.e., averaging is to be performed only over durations of active transmissions at maximum output power level). Thus, when performing this measurement, the EUT must either be configured to transmit continuously at full power while the compliance measurement is performed, or else the measurement instrumentation must be configured to acquire data only over durations when the EUT is actively transmitting at full power. In circumstances where neither of these conditions can be realized, then alternative procedures are provided for both constant duty cycle and non-constant duty cycle transmissions. The PSD is measured following the same procedures described in 5.2.4.4 for measuring the total average power, but with the RBW set to the reference bandwidth specified by the applicable regulatory requirement, and by using the marker function to identify the maximum PSD instead of summing the power across the OBW. If the fundamental measurement condition cannot be realized, then one of the alternative procedures in 5.2.4.4.2 or 5.2.4.4.3 should be selected, based on whether the transmitter duty cycle is constant (variations  $\leq \pm 2\%$ ) or non-constant (variations  $> \pm 2\%$ ), respectively.

**Note:** The results of the Conducted output power and PSD test shown above the frequency measured values are very small and similar trend for each port, so we are attached only the worst case plot.

**Test Results:**
**Tabular Data of RF output power**
**B2 DSS 15 MHz 8to2 1 Carrier**

| Ant. | Mod    | Ch     | Frequency (MHz) | Measured Value (dBm) | Calculated (W) |
|------|--------|--------|-----------------|----------------------|----------------|
| 1    | QPSK   | Middle | 1960.00         | 45.63                | 36.58          |
|      | 16QAM  | Middle | 1960.00         | 45.62                | 36.47          |
|      | 64QAM  | Middle | 1960.00         | 45.63                | 36.57          |
|      | 256QAM | Middle | 1960.00         | 45.62                | 36.44          |

**B2 DSS 15 MHz 7to3 1 Carrier**

| Ant. | Mod    | Ch     | Frequency (MHz) | Measured Value (dBm) | Calculated (W) |
|------|--------|--------|-----------------|----------------------|----------------|
| 1    | QPSK   | Middle | 1960.00         | 45.58                | 36.14          |
|      | 16QAM  | Middle | 1960.00         | 45.55                | 35.91          |
|      | 64QAM  | Middle | 1960.00         | 45.52                | 35.61          |
|      | 256QAM | Middle | 1960.00         | 45.54                | 35.79          |

**B2 DSS 15 MHz 6to4 1 Carrier**

| Ant. | Mod    | Ch     | Frequency (MHz) | Measured Value (dBm) | Calculated (W) |
|------|--------|--------|-----------------|----------------------|----------------|
| 1    | QPSK   | Middle | 1960.00         | 45.52                | 35.67          |
|      | 16QAM  | Middle | 1960.00         | 45.50                | 35.47          |
|      | 64QAM  | Middle | 1960.00         | 45.46                | 35.17          |
|      | 256QAM | Middle | 1960.00         | 45.53                | 35.77          |

**B2 DSS 15 MHz 4to6 1 Carrier**

| Ant. | Mod    | Ch     | Frequency (MHz) | Measured Value (dBm) | Calculated (W) |
|------|--------|--------|-----------------|----------------------|----------------|
| 1    | QPSK   | Middle | 1960.00         | 45.48                | 35.36          |
|      | 16QAM  | Middle | 1960.00         | 45.53                | 35.69          |
|      | 64QAM  | Middle | 1960.00         | 45.44                | 35.03          |
|      | 256QAM | Middle | 1960.00         | 45.55                | 35.87          |

**B2 DSS 15 MHz 3to7 1 Carrier**

| Ant. | Mod    | Ch     | Frequency (MHz) | Measured Value (dBm) | Calculated (W) |
|------|--------|--------|-----------------|----------------------|----------------|
| 1    | QPSK   | Middle | 1960.00         | 45.51                | 35.56          |
|      | 16QAM  | Middle | 1960.00         | 45.43                | 34.92          |
|      | 64QAM  | Middle | 1960.00         | 45.47                | 35.27          |
|      | 256QAM | Middle | 1960.00         | 45.45                | 35.10          |

\* The worst LTE:NR ratio is 9:1.

**B2 DSS 15 MHz 9to1 1 Carrier**

| Ant. | Mod    | Ch     | Frequency (MHz) | Measured Value (dBm) | Calculated (W) |
|------|--------|--------|-----------------|----------------------|----------------|
| 0    | QPSK   | Low    | 1937.50         | 45.82                | 38.21          |
|      |        | Middle | 1960.00         | 45.65                | 36.76          |
|      |        | High   | 1982.50         | 45.61                | 36.37          |
|      | 16QAM  | Low    | 1937.50         | 45.86                | 38.53          |
|      |        | Middle | 1960.00         | 45.67                | 36.93          |
|      |        | High   | 1982.50         | 45.71                | 37.20          |
|      | 64QAM  | Low    | 1937.50         | 45.85                | 38.42          |
|      |        | Middle | 1960.00         | 45.59                | 36.22          |
|      |        | High   | 1982.50         | 45.68                | 36.97          |
|      | 256QAM | Low    | 1937.50         | 45.91                | 38.99          |
|      |        | Middle | 1960.00         | 45.58                | 36.18          |
|      |        | High   | 1982.50         | 45.69                | 37.08          |
| 1    | QPSK   | Low    | 1937.50         | 45.82                | 38.18          |
|      |        | Middle | 1960.00         | 45.67                | 36.91          |
|      |        | High   | 1982.50         | 45.75                | 37.55          |
|      | 16QAM  | Low    | 1937.50         | 45.76                | 37.67          |
|      |        | Middle | 1960.00         | 45.64                | 36.65          |
|      |        | High   | 1982.50         | 45.80                | 38.02          |
|      | 64QAM  | Low    | 1937.50         | 45.74                | 37.45          |
|      |        | Middle | 1960.00         | 45.63                | 36.54          |
|      |        | High   | 1982.50         | 45.80                | 38.02          |
|      | 256QAM | Low    | 1937.50         | 45.80                | 38.05          |
|      |        | Middle | 1960.00         | 45.63                | 36.59          |
|      |        | High   | 1982.50         | 45.74                | 37.48          |

| Ant. | Mod    | Ch     | Frequency (MHz) | Measured Value (dBm) | Calculated (W) |
|------|--------|--------|-----------------|----------------------|----------------|
| 2    | QPSK   | Low    | 1937.50         | 45.64                | 36.68          |
|      |        | Middle | 1960.00         | 45.56                | 35.98          |
|      |        | High   | 1982.50         | 45.62                | 36.50          |
|      | 16QAM  | Low    | 1937.50         | 45.72                | 37.30          |
|      |        | Middle | 1960.00         | 45.55                | 35.86          |
|      |        | High   | 1982.50         | 45.69                | 37.08          |
|      | 64QAM  | Low    | 1937.50         | 45.69                | 37.03          |
|      |        | Middle | 1960.00         | 45.50                | 35.47          |
|      |        | High   | 1982.50         | 45.58                | 36.18          |
|      | 256QAM | Low    | 1937.50         | 45.61                | 36.36          |
|      |        | Middle | 1960.00         | 45.50                | 35.50          |
|      |        | High   | 1982.50         | 45.66                | 36.85          |
| 3    | QPSK   | Low    | 1937.50         | 45.80                | 38.06          |
|      |        | Middle | 1960.00         | 45.67                | 36.91          |
|      |        | High   | 1982.50         | 45.77                | 37.71          |
|      | 16QAM  | Low    | 1937.50         | 45.79                | 37.91          |
|      |        | Middle | 1960.00         | 45.73                | 37.45          |
|      |        | High   | 1982.50         | 45.66                | 36.85          |
|      | 64QAM  | Low    | 1937.50         | 45.75                | 37.63          |
|      |        | Middle | 1960.00         | 45.62                | 36.48          |
|      |        | High   | 1982.50         | 45.69                | 37.03          |
|      | 256QAM | Low    | 1937.50         | 45.86                | 38.52          |
|      |        | Middle | 1960.00         | 45.63                | 36.58          |
|      |        | High   | 1982.50         | 45.70                | 37.15          |

**Sum Data of Port 0, Port 1, Port 2 and Port 3**

| Frequency (MHz) | Output Power(Conducted) |        |        |        |
|-----------------|-------------------------|--------|--------|--------|
|                 | QPSK                    | 16QAM  | 64QAM  | 256QAM |
|                 | W                       |        |        |        |
| 1937.50         | 151.13                  | 151.41 | 150.54 | 151.93 |
| 1960.00         | 146.57                  | 146.89 | 144.71 | 144.86 |
| 1982.50         | 148.14                  | 149.15 | 148.20 | 148.56 |

**B2 DSS 15 MHz 5to5 1 Carrier**

| Ant. | Mod    | Ch     | Frequency (MHz) | Measured Value (dBm) | Calculated (W) |
|------|--------|--------|-----------------|----------------------|----------------|
| 0    | QPSK   | Low    | 1937.50         | 45.68                | 36.96          |
|      |        | Middle | 1960.00         | 45.48                | 35.28          |
|      |        | High   | 1982.50         | 45.53                | 35.70          |
|      | 16QAM  | Low    | 1937.50         | 45.65                | 36.75          |
|      |        | Middle | 1960.00         | 45.43                | 34.87          |
|      |        | High   | 1982.50         | 45.59                | 36.18          |
|      | 64QAM  | Low    | 1937.50         | 45.66                | 36.78          |
|      |        | Middle | 1960.00         | 45.49                | 35.43          |
|      |        | High   | 1982.50         | 45.49                | 35.42          |
|      | 256QAM | Low    | 1937.50         | 45.62                | 36.44          |
|      |        | Middle | 1960.00         | 45.45                | 35.09          |
|      |        | High   | 1982.50         | 45.48                | 35.33          |
| 1    | QPSK   | Low    | 1937.50         | 45.64                | 36.60          |
|      |        | Middle | 1960.00         | 45.56                | 35.97          |
|      |        | High   | 1982.50         | 45.59                | 36.19          |
|      | 16QAM  | Low    | 1937.50         | 45.67                | 36.86          |
|      |        | Middle | 1960.00         | 45.56                | 35.98          |
|      |        | High   | 1982.50         | 45.63                | 36.58          |
|      | 64QAM  | Low    | 1937.50         | 45.75                | 37.57          |
|      |        | Middle | 1960.00         | 45.55                | 35.91          |
|      |        | High   | 1982.50         | 45.58                | 36.13          |
|      | 256QAM | Low    | 1937.50         | 45.65                | 36.72          |
|      |        | Middle | 1960.00         | 45.57                | 36.02          |
|      |        | High   | 1982.50         | 45.64                | 36.68          |



| Ant. | Mod    | Ch     | Frequency (MHz) | Measured Value (dBm) | Calculated (W) |
|------|--------|--------|-----------------|----------------------|----------------|
| 2    | QPSK   | Low    | 1937.50         | 45.58                | 36.14          |
|      |        | Middle | 1960.00         | 45.41                | 34.78          |
|      |        | High   | 1982.50         | 45.43                | 34.89          |
|      | 16QAM  | Low    | 1937.50         | 45.54                | 35.84          |
|      |        | Middle | 1960.00         | 45.38                | 34.54          |
|      |        | High   | 1982.50         | 45.46                | 35.12          |
|      | 64QAM  | Low    | 1937.50         | 45.53                | 35.70          |
|      |        | Middle | 1960.00         | 45.36                | 34.39          |
|      |        | High   | 1982.50         | 45.48                | 35.28          |
|      | 256QAM | Low    | 1937.50         | 45.50                | 35.47          |
|      |        | Middle | 1960.00         | 45.44                | 35.02          |
|      |        | High   | 1982.50         | 45.50                | 35.48          |
| 3    | QPSK   | Low    | 1937.50         | 45.56                | 35.98          |
|      |        | Middle | 1960.00         | 45.53                | 35.75          |
|      |        | High   | 1982.50         | 45.55                | 35.87          |
|      | 16QAM  | Low    | 1937.50         | 45.70                | 37.15          |
|      |        | Middle | 1960.00         | 45.55                | 35.88          |
|      |        | High   | 1982.50         | 45.49                | 35.38          |
|      | 64QAM  | Low    | 1937.50         | 45.60                | 36.27          |
|      |        | Middle | 1960.00         | 45.50                | 35.51          |
|      |        | High   | 1982.50         | 45.56                | 35.95          |
|      | 256QAM | Low    | 1937.50         | 45.72                | 37.33          |
|      |        | Middle | 1960.00         | 45.52                | 35.66          |
|      |        | High   | 1982.50         | 45.52                | 35.69          |

**Sum Data of Port 0, Port 1, Port 2 and Port 3**

| Frequency (MHz) | Output Power(Conducted) |        |        |        |
|-----------------|-------------------------|--------|--------|--------|
|                 | QPSK                    | 16QAM  | 64QAM  | 256QAM |
|                 | W                       |        |        |        |
| 1937.50         | 145.68                  | 146.60 | 146.32 | 145.97 |
| 1960.00         | 141.77                  | 141.28 | 141.23 | 141.80 |
| 1982.50         | 142.65                  | 143.25 | 142.78 | 143.17 |

**B2 DSS 15 MHz 2to8 1 Carrier**

| Ant. | Mod    | Ch     | Frequency (MHz) | Measured Value (dBm) | Calculated (W) |
|------|--------|--------|-----------------|----------------------|----------------|
| 0    | QPSK   | Low    | 1937.50         | 45.60                | 36.28          |
|      |        | Middle | 1960.00         | 45.37                | 34.42          |
|      |        | High   | 1982.50         | 45.40                | 34.71          |
|      | 16QAM  | Low    | 1937.50         | 45.62                | 36.48          |
|      |        | Middle | 1960.00         | 45.30                | 33.87          |
|      |        | High   | 1982.50         | 45.38                | 34.54          |
|      | 64QAM  | Low    | 1937.50         | 45.66                | 36.81          |
|      |        | Middle | 1960.00         | 45.28                | 33.74          |
|      |        | High   | 1982.50         | 45.26                | 33.55          |
|      | 256QAM | Low    | 1937.50         | 45.64                | 36.64          |
|      |        | Middle | 1960.00         | 45.41                | 34.75          |
|      |        | High   | 1982.50         | 45.37                | 34.40          |
| 1    | QPSK   | Low    | 1937.50         | 45.56                | 36.00          |
|      |        | Middle | 1960.00         | 45.49                | 35.42          |
|      |        | High   | 1982.50         | 45.46                | 35.12          |
|      | 16QAM  | Low    | 1937.50         | 45.64                | 36.61          |
|      |        | Middle | 1960.00         | 45.44                | 35.03          |
|      |        | High   | 1982.50         | 45.48                | 35.32          |
|      | 64QAM  | Low    | 1937.50         | 45.65                | 36.74          |
|      |        | Middle | 1960.00         | 45.45                | 35.10          |
|      |        | High   | 1982.50         | 45.49                | 35.38          |
|      | 256QAM | Low    | 1937.50         | 45.59                | 36.18          |
|      |        | Middle | 1960.00         | 45.46                | 35.16          |
|      |        | High   | 1982.50         | 45.53                | 35.73          |

| Ant. | Mod    | Ch     | Frequency (MHz) | Measured Value (dBm) | Calculated (W) |
|------|--------|--------|-----------------|----------------------|----------------|
| 2    | QPSK   | Low    | 1937.50         | 45.38                | 34.51          |
|      |        | Middle | 1960.00         | 45.25                | 33.48          |
|      |        | High   | 1982.50         | 45.40                | 34.67          |
|      | 16QAM  | Low    | 1937.50         | 45.39                | 34.61          |
|      |        | Middle | 1960.00         | 45.33                | 34.15          |
|      |        | High   | 1982.50         | 45.36                | 34.40          |
|      | 64QAM  | Low    | 1937.50         | 45.39                | 34.63          |
|      |        | Middle | 1960.00         | 45.32                | 34.01          |
|      |        | High   | 1982.50         | 45.35                | 34.29          |
|      | 256QAM | Low    | 1937.50         | 45.34                | 34.23          |
|      |        | Middle | 1960.00         | 45.26                | 33.58          |
|      |        | High   | 1982.50         | 45.49                | 35.37          |
| 3    | QPSK   | Low    | 1937.50         | 45.52                | 35.69          |
|      |        | Middle | 1960.00         | 45.43                | 34.90          |
|      |        | High   | 1982.50         | 45.42                | 34.86          |
|      | 16QAM  | Low    | 1937.50         | 45.55                | 35.89          |
|      |        | Middle | 1960.00         | 45.41                | 34.75          |
|      |        | High   | 1982.50         | 45.42                | 34.82          |
|      | 64QAM  | Low    | 1937.50         | 45.51                | 35.60          |
|      |        | Middle | 1960.00         | 45.41                | 34.73          |
|      |        | High   | 1982.50         | 45.40                | 34.65          |
|      | 256QAM | Low    | 1937.50         | 45.56                | 35.97          |
|      |        | Middle | 1960.00         | 45.30                | 33.88          |
|      |        | High   | 1982.50         | 45.50                | 35.47          |

**Sum Data of Port 0, Port 1, Port 2 and Port 3**

| Frequency (MHz) | Output Power(Conducted) |        |        |        |
|-----------------|-------------------------|--------|--------|--------|
|                 | QPSK                    | 16QAM  | 64QAM  | 256QAM |
|                 | W                       |        |        |        |
| 1937.50         | 142.48                  | 143.60 | 143.78 | 143.02 |
| 1960.00         | 138.22                  | 137.80 | 137.58 | 137.38 |
| 1982.50         | 139.35                  | 139.07 | 137.88 | 140.96 |

**LTE B2 5 MHz 1 Carrier**

| Ant. | Mod  | Ch   | Frequency (MHz) | Measured Value (dBm) | Calculated (W) |
|------|------|------|-----------------|----------------------|----------------|
| 0    | QPSK | High | 1987.50         | 42.63                | 18.31          |

**LTE B2 10 MHz 1 Carrier**

| Ant. | Mod   | Ch   | Frequency (MHz) | Measured Value (dBm) | Calculated (W) |
|------|-------|------|-----------------|----------------------|----------------|
| 1    | 16QAM | High | 1985.00         | 45.73                | 37.43          |

**LTE B2 15 MHz 1 Carrier**

| Ant. | Mod    | Ch   | Frequency (MHz) | Measured Value (dBm) | Calculated (W) |
|------|--------|------|-----------------|----------------------|----------------|
| 1    | 256QAM | High | 1982.50         | 45.63                | 36.55          |

**LTE B2 20 MHz 1 Carrier**

| Ant. | Mod   | Ch   | Frequency (MHz) | Measured Value (dBm) | Calculated (W) |
|------|-------|------|-----------------|----------------------|----------------|
| 1    | 16QAM | High | 1980.00         | 45.76                | 37.64          |

Plot Data of RF Output Power

Antenna 0 / B2 DSS 15 MHz 9to1 1 Carrier / 256QAM / Low

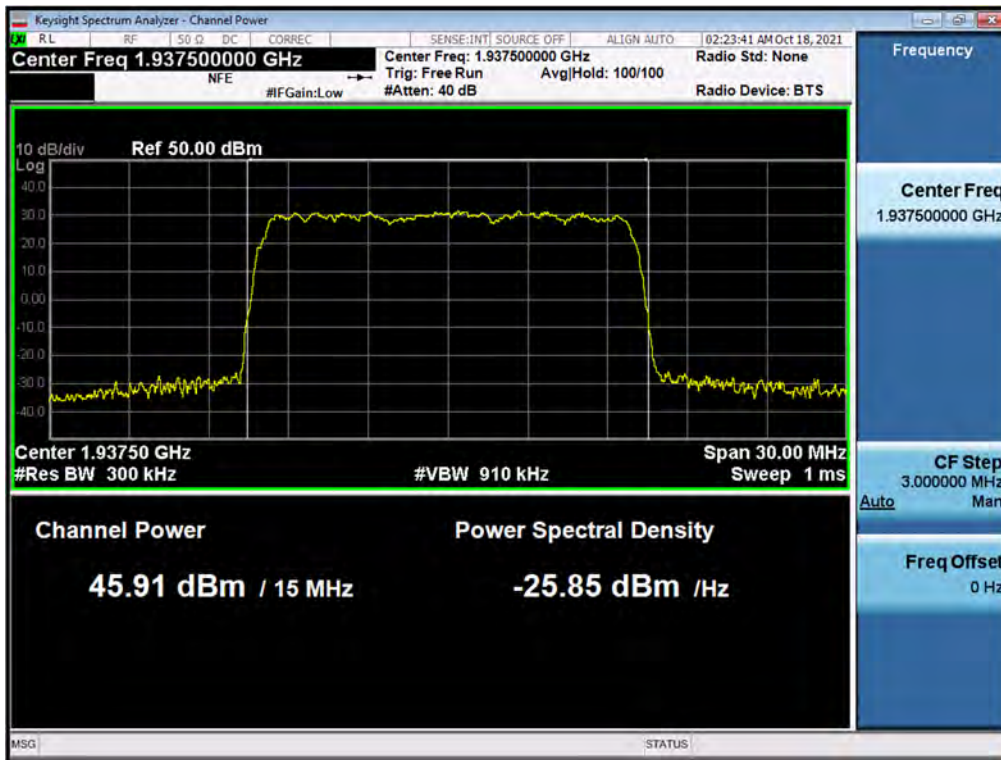

Antenna 1 / B2 DSS 15 MHz 5to5 1 Carrier / 64QAM / Low

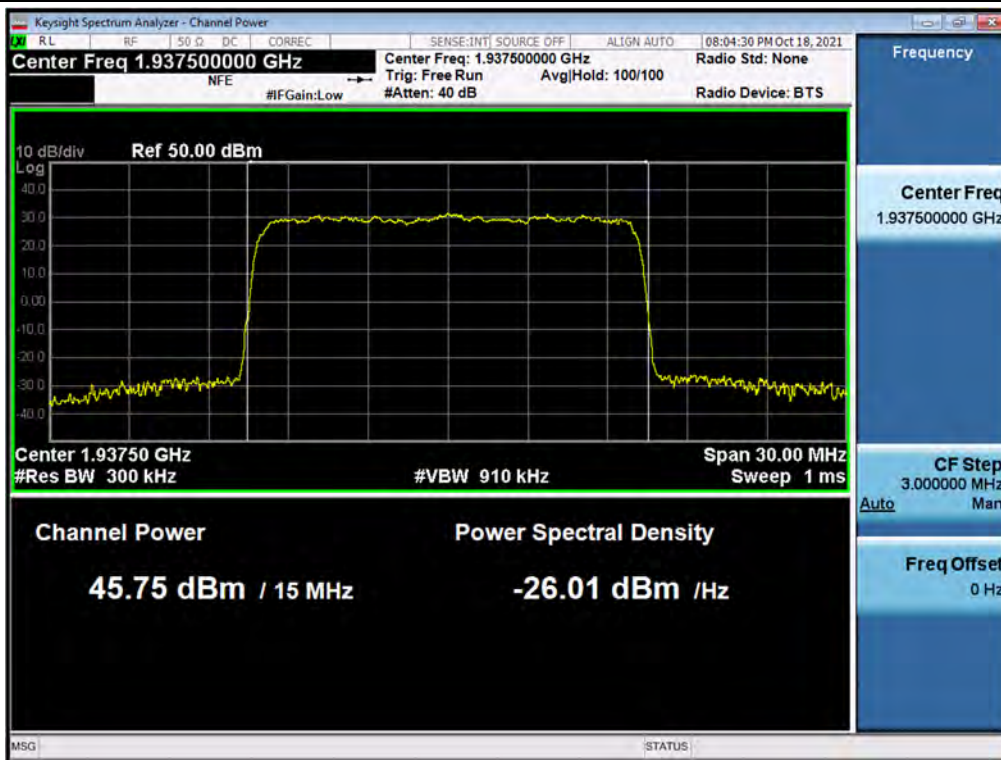

Antenna 0 / B2 DSS 15 MHz 2to8 1 Carrier / 64QAM / Low

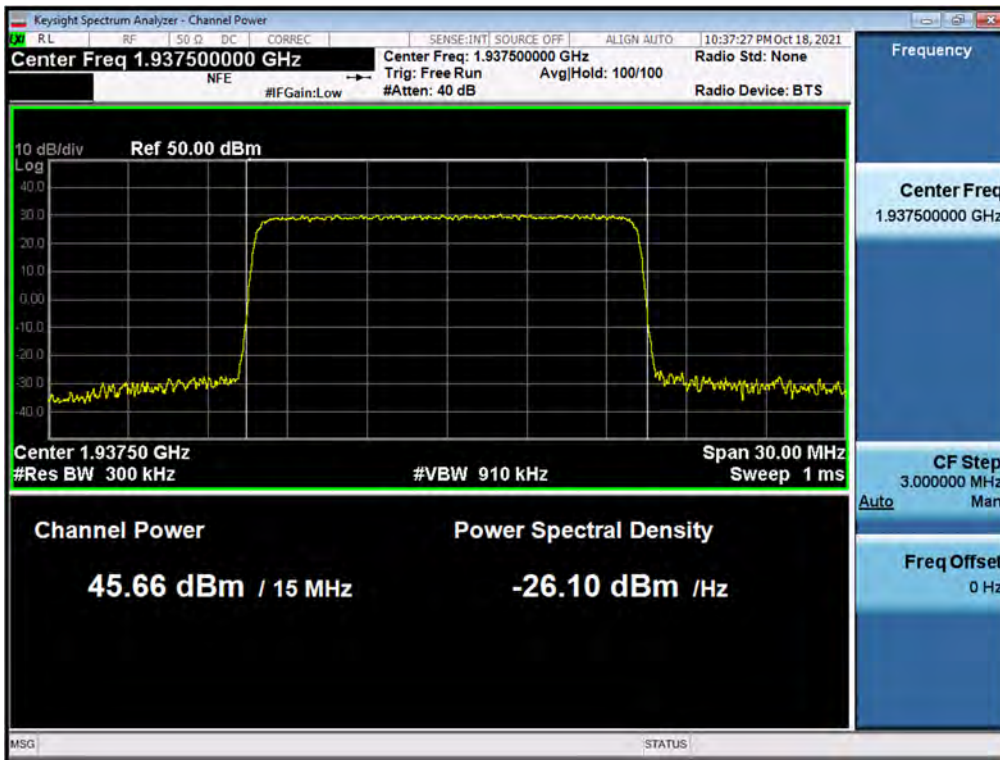

Antenna 1 / LTE B2 20 MHz 1 Carrier / 16QAM / High

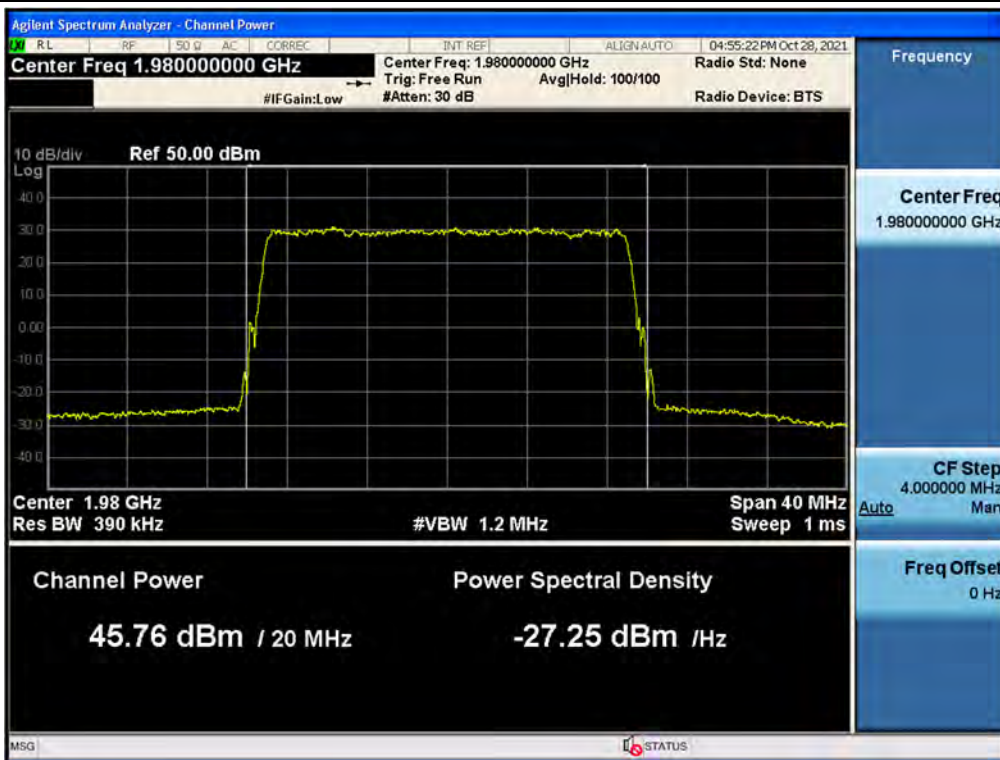

## Tabular Data of PSD

## B2 DSS 15 MHz 9to1 1 Carrier

| Ant. | Mod    | Ch     | Frequency (MHz) | Measured Value (dBm/MHz) | Calculated (W/MHz) |
|------|--------|--------|-----------------|--------------------------|--------------------|
| 0    | QPSK   | Low    | 1937.50         | 35.89                    | 3.89               |
|      |        | Middle | 1960.00         | 35.25                    | 3.35               |
|      |        | High   | 1982.50         | 35.26                    | 3.36               |
|      | 16QAM  | Low    | 1937.50         | 35.67                    | 3.69               |
|      |        | Middle | 1960.00         | 35.52                    | 3.56               |
|      |        | High   | 1982.50         | 35.40                    | 3.46               |
|      | 64QAM  | Low    | 1937.50         | 36.27                    | 4.24               |
|      |        | Middle | 1960.00         | 36.24                    | 4.21               |
|      |        | High   | 1982.50         | 36.03                    | 4.01               |
|      | 256QAM | Low    | 1937.50         | 36.52                    | 4.49               |
|      |        | Middle | 1960.00         | 36.20                    | 4.17               |
|      |        | High   | 1982.50         | 35.97                    | 3.95               |
| 1    | QPSK   | Low    | 1937.50         | 35.64                    | 3.67               |
|      |        | Middle | 1960.00         | 35.58                    | 3.61               |
|      |        | High   | 1982.50         | 35.52                    | 3.57               |
|      | 16QAM  | Low    | 1937.50         | 35.65                    | 3.67               |
|      |        | Middle | 1960.00         | 35.52                    | 3.56               |
|      |        | High   | 1982.50         | 35.61                    | 3.64               |
|      | 64QAM  | Low    | 1937.50         | 36.48                    | 4.44               |
|      |        | Middle | 1960.00         | 35.74                    | 3.75               |
|      |        | High   | 1982.50         | 36.11                    | 4.08               |
|      | 256QAM | Low    | 1937.50         | 36.40                    | 4.36               |
|      |        | Middle | 1960.00         | 36.59                    | 4.56               |
|      |        | High   | 1982.50         | 36.36                    | 4.33               |

| Ant.   | Mod    | Ch      | Frequency (MHz) | Measured Value (dBm/MHz) | Calculated (W/MHz) |
|--------|--------|---------|-----------------|--------------------------|--------------------|
| 2      | QPSK   | Low     | 1937.50         | 35.43                    | 3.49               |
|        |        | Middle  | 1960.00         | 35.40                    | 3.47               |
|        |        | High    | 1982.50         | 35.66                    | 3.68               |
|        | 16QAM  | Low     | 1937.50         | 35.25                    | 3.35               |
|        |        | Middle  | 1960.00         | 35.36                    | 3.43               |
|        |        | High    | 1982.50         | 35.72                    | 3.73               |
|        | 64QAM  | Low     | 1937.50         | 36.16                    | 4.13               |
|        |        | Middle  | 1960.00         | 36.10                    | 4.07               |
|        |        | High    | 1982.50         | 36.24                    | 4.20               |
| 256QAM | Low    | 1937.50 | 36.31           | 4.27                     |                    |
|        | Middle | 1960.00 | 35.89           | 3.88                     |                    |
|        | High   | 1982.50 | 36.14           | 4.11                     |                    |
| 3      | QPSK   | Low     | 1937.50         | 35.45                    | 3.51               |
|        |        | Middle  | 1960.00         | 35.24                    | 3.34               |
|        |        | High    | 1982.50         | 35.38                    | 3.45               |
|        | 16QAM  | Low     | 1937.50         | 35.55                    | 3.59               |
|        |        | Middle  | 1960.00         | 35.43                    | 3.49               |
|        |        | High    | 1982.50         | 35.40                    | 3.47               |
|        | 64QAM  | Low     | 1937.50         | 36.58                    | 4.55               |
|        |        | Middle  | 1960.00         | 36.14                    | 4.12               |
|        |        | High    | 1982.50         | 36.27                    | 4.23               |
| 256QAM | Low    | 1937.50 | 36.27           | 4.23                     |                    |
|        | Middle | 1960.00 | 36.07           | 4.04                     |                    |
|        | High   | 1982.50 | 36.13           | 4.10                     |                    |

**Sum Data of Port 0, Port 1, Port 2 and Port 3**

| Frequency (MHz) | PSD   |       |       |        |
|-----------------|-------|-------|-------|--------|
|                 | QPSK  | 16QAM | 64QAM | 256QAM |
|                 | W/MHz |       |       |        |
| 1937.50         | 14.56 | 14.30 | 17.37 | 17.36  |
| 1960.00         | 13.77 | 14.05 | 16.15 | 16.66  |
| 1982.50         | 14.06 | 14.30 | 16.53 | 16.49  |



**B2 DSS 15 MHz 5to5 1 Carrier**

| Ant.   | Mod    | Ch      | Frequency (MHz) | Measured Value (dBm/MHz) | Calculated (W/MHz) |
|--------|--------|---------|-----------------|--------------------------|--------------------|
| 0      | QPSK   | Low     | 1937.50         | 35.40                    | 3.46               |
|        |        | Middle  | 1960.00         | 35.23                    | 3.34               |
|        |        | High    | 1982.50         | 35.12                    | 3.25               |
|        | 16QAM  | Low     | 1937.50         | 35.82                    | 3.82               |
|        |        | Middle  | 1960.00         | 35.77                    | 3.78               |
|        |        | High    | 1982.50         | 35.88                    | 3.87               |
|        | 64QAM  | Low     | 1937.50         | 36.05                    | 4.03               |
|        |        | Middle  | 1960.00         | 35.68                    | 3.70               |
|        |        | High    | 1982.50         | 35.47                    | 3.52               |
| 256QAM | Low    | 1937.50 | 35.78           | 3.79                     |                    |
|        | Middle | 1960.00 | 36.07           | 4.04                     |                    |
|        | High   | 1982.50 | 35.80           | 3.80                     |                    |
| 1      | QPSK   | Low     | 1937.50         | 35.71                    | 3.72               |
|        |        | Middle  | 1960.00         | 35.19                    | 3.30               |
|        |        | High    | 1982.50         | 35.22                    | 3.33               |
|        | 16QAM  | Low     | 1937.50         | 35.94                    | 3.92               |
|        |        | Middle  | 1960.00         | 35.96                    | 3.95               |
|        |        | High    | 1982.50         | 36.05                    | 4.03               |
|        | 64QAM  | Low     | 1937.50         | 35.90                    | 3.89               |
|        |        | Middle  | 1960.00         | 35.60                    | 3.63               |
|        |        | High    | 1982.50         | 35.89                    | 3.88               |
| 256QAM | Low    | 1937.50 | 35.83           | 3.82                     |                    |
|        | Middle | 1960.00 | 35.73           | 3.74                     |                    |
|        | High   | 1982.50 | 35.67           | 3.69                     |                    |

| Ant.   | Mod    | Ch      | Frequency (MHz) | Measured Value (dBm/MHz) | Calculated (W/MHz) |
|--------|--------|---------|-----------------|--------------------------|--------------------|
| 2      | QPSK   | Low     | 1937.50         | 35.09                    | 3.22               |
|        |        | Middle  | 1960.00         | 35.09                    | 3.23               |
|        |        | High    | 1982.50         | 34.98                    | 3.15               |
|        | 16QAM  | Low     | 1937.50         | 35.97                    | 3.95               |
|        |        | Middle  | 1960.00         | 35.75                    | 3.76               |
|        |        | High    | 1982.50         | 35.77                    | 3.78               |
|        | 64QAM  | Low     | 1937.50         | 35.86                    | 3.86               |
|        |        | Middle  | 1960.00         | 35.45                    | 3.51               |
|        |        | High    | 1982.50         | 35.60                    | 3.63               |
| 256QAM | Low    | 1937.50 | 35.61           | 3.64                     |                    |
|        | Middle | 1960.00 | 35.65           | 3.67                     |                    |
|        | High   | 1982.50 | 35.70           | 3.72                     |                    |
| 3      | QPSK   | Low     | 1937.50         | 35.45                    | 3.51               |
|        |        | Middle  | 1960.00         | 35.34                    | 3.42               |
|        |        | High    | 1982.50         | 35.09                    | 3.23               |
|        | 16QAM  | Low     | 1937.50         | 35.85                    | 3.84               |
|        |        | Middle  | 1960.00         | 35.55                    | 3.59               |
|        |        | High    | 1982.50         | 35.71                    | 3.72               |
|        | 64QAM  | Low     | 1937.50         | 36.05                    | 4.03               |
|        |        | Middle  | 1960.00         | 35.94                    | 3.93               |
|        |        | High    | 1982.50         | 36.01                    | 3.99               |
| 256QAM | Low    | 1937.50 | 35.98           | 3.96                     |                    |
|        | Middle | 1960.00 | 35.78           | 3.79                     |                    |
|        | High   | 1982.50 | 35.83           | 3.82                     |                    |

**Sum Data of Port 0, Port 1, Port 2 and Port 3**

| Frequency (MHz) | PSD   |       |       |        |
|-----------------|-------|-------|-------|--------|
|                 | QPSK  | 16QAM | 64QAM | 256QAM |
|                 | W/MHz |       |       |        |
| 1937.50         | 13.92 | 15.54 | 15.80 | 15.21  |
| 1960.00         | 13.29 | 15.07 | 14.76 | 15.25  |
| 1982.50         | 12.96 | 15.40 | 15.02 | 15.03  |

**B2 DSS 15 MHz 2to8 1 Carrier**

| Ant.   | Mod    | Ch      | Frequency (MHz) | Measured Value (dBm/MHz) | Calculated (W/MHz) |
|--------|--------|---------|-----------------|--------------------------|--------------------|
| 0      | QPSK   | Low     | 1937.50         | 35.31                    | 3.39               |
|        |        | Middle  | 1960.00         | 34.93                    | 3.11               |
|        |        | High    | 1982.50         | 35.04                    | 3.19               |
|        | 16QAM  | Low     | 1937.50         | 36.23                    | 4.20               |
|        |        | Middle  | 1960.00         | 35.87                    | 3.86               |
|        |        | High    | 1982.50         | 35.91                    | 3.90               |
|        | 64QAM  | Low     | 1937.50         | 35.30                    | 3.39               |
|        |        | Middle  | 1960.00         | 35.27                    | 3.36               |
|        |        | High    | 1982.50         | 35.37                    | 3.44               |
| 256QAM | Low    | 1937.50 | 35.76           | 3.76                     |                    |
|        | Middle | 1960.00 | 35.43           | 3.49                     |                    |
|        | High   | 1982.50 | 35.14           | 3.27                     |                    |
| 1      | QPSK   | Low     | 1937.50         | 35.13                    | 3.26               |
|        |        | Middle  | 1960.00         | 34.97                    | 3.14               |
|        |        | High    | 1982.50         | 35.04                    | 3.19               |
|        | 16QAM  | Low     | 1937.50         | 36.29                    | 4.26               |
|        |        | Middle  | 1960.00         | 36.00                    | 3.98               |
|        |        | High    | 1982.50         | 35.97                    | 3.96               |
|        | 64QAM  | Low     | 1937.50         | 35.13                    | 3.26               |
|        |        | Middle  | 1960.00         | 35.86                    | 3.85               |
|        |        | High    | 1982.50         | 35.38                    | 3.45               |
| 256QAM | Low    | 1937.50 | 35.73           | 3.74                     |                    |
|        | Middle | 1960.00 | 35.14           | 3.27                     |                    |
|        | High   | 1982.50 | 35.25           | 3.35                     |                    |

| Ant.   | Mod    | Ch      | Frequency (MHz) | Measured Value (dBm/MHz) | Calculated (W/MHz) |
|--------|--------|---------|-----------------|--------------------------|--------------------|
| 2      | QPSK   | Low     | 1937.50         | 34.95                    | 3.13               |
|        |        | Middle  | 1960.00         | 35.06                    | 3.21               |
|        |        | High    | 1982.50         | 35.10                    | 3.24               |
|        | 16QAM  | Low     | 1937.50         | 36.13                    | 4.10               |
|        |        | Middle  | 1960.00         | 35.82                    | 3.82               |
|        |        | High    | 1982.50         | 36.09                    | 4.06               |
|        | 64QAM  | Low     | 1937.50         | 34.81                    | 3.02               |
|        |        | Middle  | 1960.00         | 35.48                    | 3.53               |
|        |        | High    | 1982.50         | 35.37                    | 3.45               |
| 256QAM | Low    | 1937.50 | 35.24           | 3.34                     |                    |
|        | Middle | 1960.00 | 34.97           | 3.14                     |                    |
|        | High   | 1982.50 | 35.40           | 3.46                     |                    |
| 3      | QPSK   | Low     | 1937.50         | 35.39                    | 3.46               |
|        |        | Middle  | 1960.00         | 34.94                    | 3.12               |
|        |        | High    | 1982.50         | 35.25                    | 3.35               |
|        | 16QAM  | Low     | 1937.50         | 36.55                    | 4.52               |
|        |        | Middle  | 1960.00         | 35.98                    | 3.97               |
|        |        | High    | 1982.50         | 36.00                    | 3.98               |
|        | 64QAM  | Low     | 1937.50         | 35.35                    | 3.43               |
|        |        | Middle  | 1960.00         | 35.41                    | 3.47               |
|        |        | High    | 1982.50         | 35.40                    | 3.47               |
| 256QAM | Low    | 1937.50 | 35.46           | 3.51                     |                    |
|        | Middle | 1960.00 | 35.15           | 3.27                     |                    |
|        | High   | 1982.50 | 35.47           | 3.52                     |                    |

**Sum Data of Port 0, Port 1, Port 2 and Port 3**

| Frequency (MHz) | PSD   |       |       |        |
|-----------------|-------|-------|-------|--------|
|                 | QPSK  | 16QAM | 64QAM | 256QAM |
|                 | W/MHz |       |       |        |
| 1937.50         | 13.24 | 17.08 | 13.10 | 14.36  |
| 1960.00         | 12.58 | 15.63 | 14.22 | 13.17  |
| 1982.50         | 12.97 | 15.90 | 13.81 | 13.60  |

**LTE B2 5 MHz 1 Carrier**

| Ant. | Mod  | Ch   | Frequency (MHz) | Measured Value (dBm/MHz) | Calculated (W/MHz) |
|------|------|------|-----------------|--------------------------|--------------------|
| 0    | QPSK | High | 1986.47         | 37.38                    | 5.47               |

**LTE B2 10 MHz 1 Carrier**

| Ant. | Mod   | Ch   | Frequency (MHz) | Measured Value (dBm/MHz) | Calculated (W/MHz) |
|------|-------|------|-----------------|--------------------------|--------------------|
| 1    | 16QAM | High | 1984.88         | 37.48                    | 5.60               |

**LTE B2 15 MHz 1 Carrier**

| Ant. | Mod    | Ch   | Frequency (MHz) | Measured Value (dBm/MHz) | Calculated (W/MHz) |
|------|--------|------|-----------------|--------------------------|--------------------|
| 1    | 256QAM | High | 1986.10         | 35.43                    | 3.49               |

**LTE B2 20 MHz 1 Carrier**

| Ant. | Mod   | Ch   | Frequency (MHz) | Measured Value (dBm/MHz) | Calculated (W/MHz) |
|------|-------|------|-----------------|--------------------------|--------------------|
| 1    | 16QAM | High | 1984.20         | 34.73                    | 2.97               |

## Plot Data of PSD

### Antenna 0 / B2 DSS 15 MHz 9to1 1 Carrier / 256QAM / Low

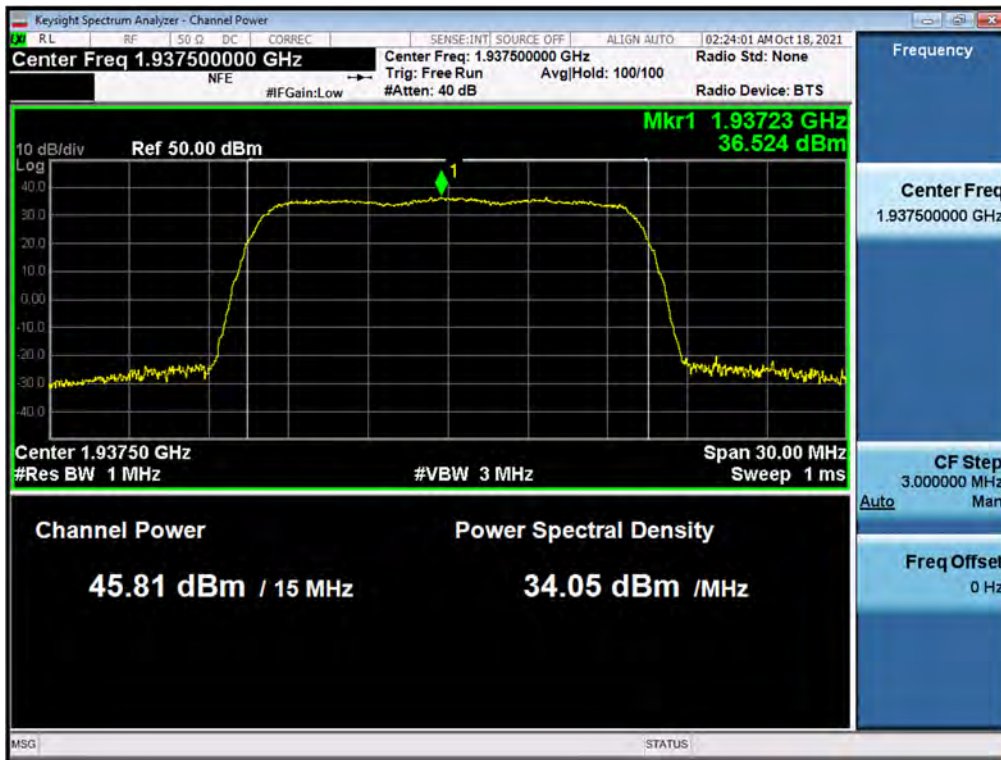

### Antenna 1 / B2 DSS 15 MHz 5to5 1 Carrier / 64QAM / Low

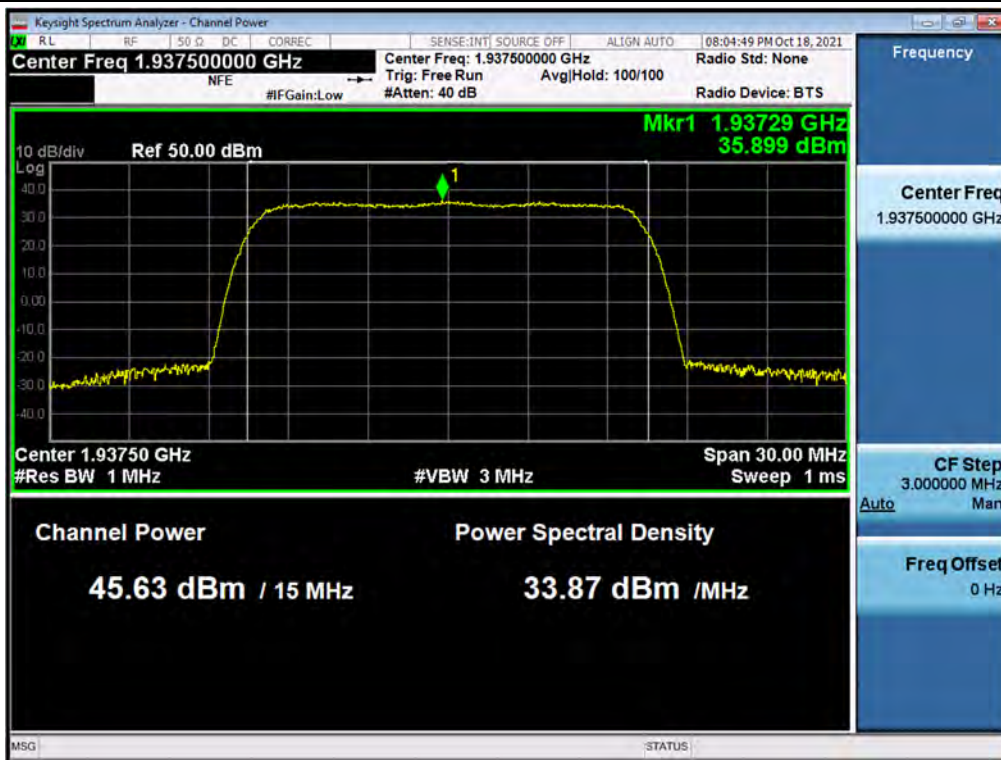

Antenna 0 / B2 DSS 15 MHz 2to8 1 Carrier / 64QAM / Low

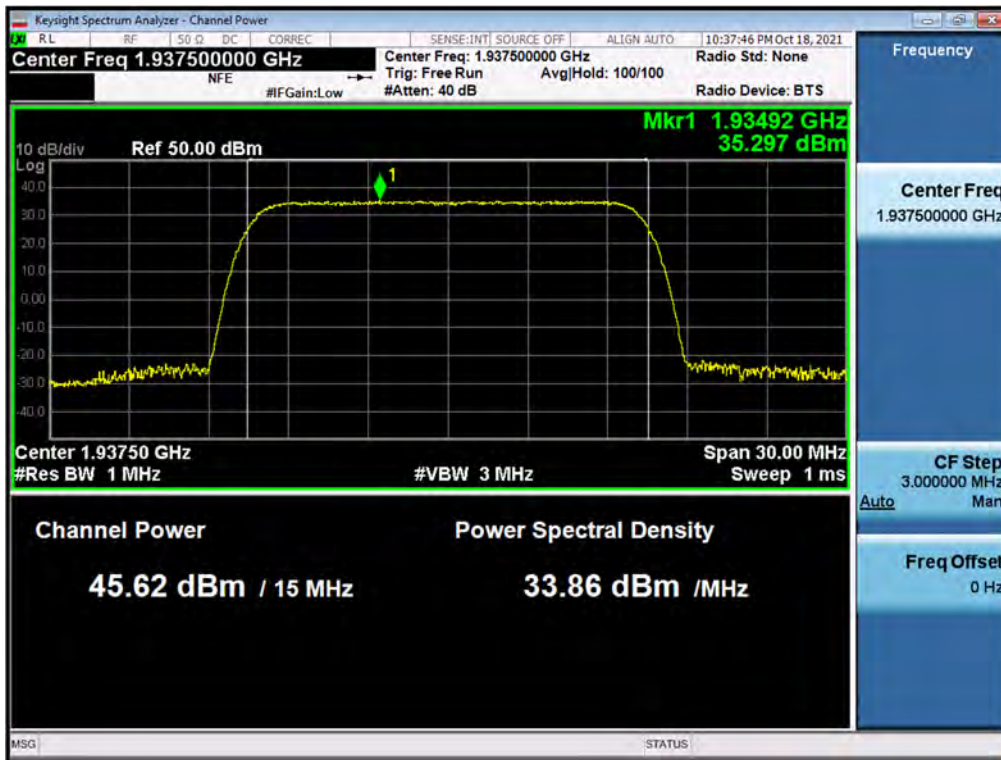

Antenna 1 / LTE B2 20 MHz 1 Carrier / 16QAM / High

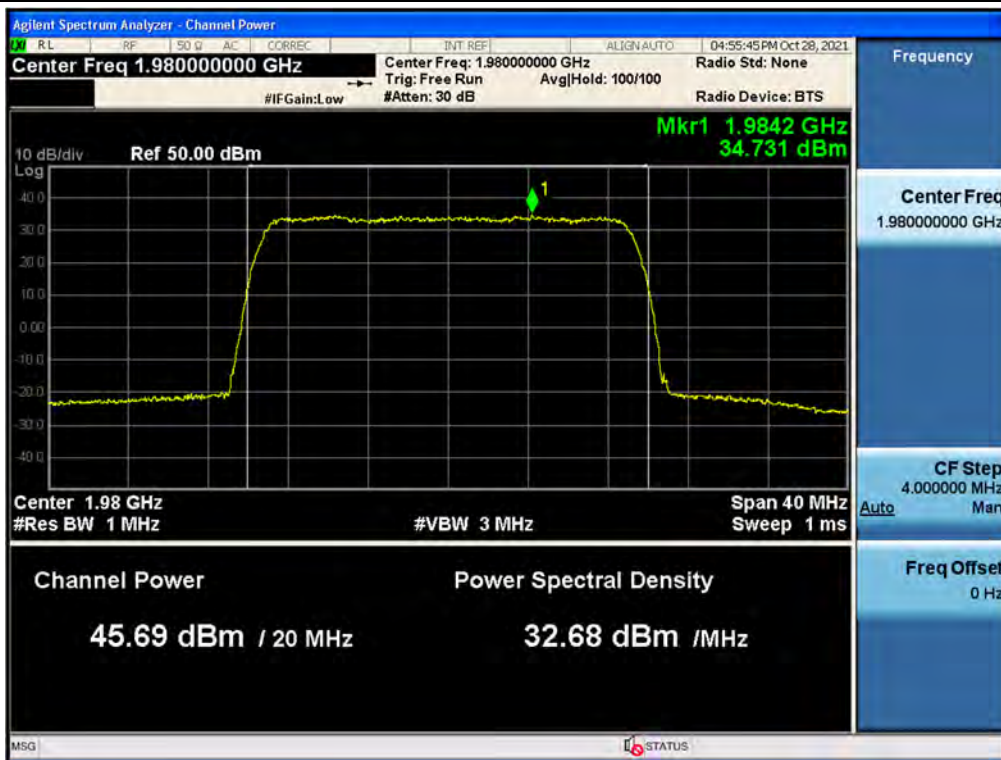

## 5.2. PAPR

### Test Requirements:

#### § 24.232 Power and antenna height limits.

- (d) Power measurements for transmissions by stations authorized under this section may be made either in accordance with a Commission-approved average power technique or in compliance with paragraph (e) of this section. In both instances, equipment employed must be authorized in accordance with the provisions of § 24.51. In measuring transmissions in this band using an average power technique, the peak-to-average ratio (PAR) of the transmission may not exceed 13 dB.

### Test Procedures:

The measurement is performed in accordance with Section 5.2.3.4 of ANSI C63.26.

The following guidelines are offered for performing a CCDF measurement..

- a) Set resolution/measurement bandwidth  $\geq$  OBW or specified reference bandwidth.
- b) Set the number of counts to a value that stabilizes the measured CCDF curve.
- c) Set the measurement interval as follows:
  - 1) For continuous transmissions, set to the greater of  $[10 \times (\text{number of points in sweep}) \times (\text{transmission symbol period})]$  or 1 ms.
  - 2) For burst transmissions, employ an external trigger that is synchronized with the EUT burst timing sequence, or use the internal burst trigger with a trigger level that allows the burst to stabilize. Set the measurement interval to a time that is less than or equal to the burst duration.
  - 3) If there are several carriers in a single antenna port, the peak power shall be determined for each individual carrier (by disabling the other carriers while measuring the required carrier) and the total peak power calculated from the sum of the individual carrier peak powers.
- d) Record the maximum PAPR level associated with a probability of 0.1%.
- e) The peak power level is calculated from the sum of the PAPR value from step d) to the measured average power.

**Note:** The results of PAPR test shown above the frequency measured values are very small and similar trend for each port, so we are attached only the worst case plot.



## Tabular data of PAPR

## B2 DSS 15 MHz 9to1 1 Carrier

| Ant. | Modulation | Channel | Frequency (MHz) | 0.1 % PAPR (dB) |
|------|------------|---------|-----------------|-----------------|
| 0    | QPSK       | Low     | 1937.50         | 7.85            |
|      |            | Middle  | 1960.00         | 7.89            |
|      |            | High    | 1982.50         | 7.90            |
|      | 16QAM      | Low     | 1937.50         | 7.83            |
|      |            | Middle  | 1960.00         | 7.90            |
|      |            | High    | 1982.50         | 7.90            |
|      | 64QAM      | Low     | 1937.50         | 7.88            |
|      |            | Middle  | 1960.00         | 7.90            |
|      |            | High    | 1982.50         | 7.84            |
|      | 256QAM     | Low     | 1937.50         | 7.90            |
|      |            | Middle  | 1960.00         | 7.92            |
|      |            | High    | 1982.50         | 7.88            |
| 1    | QPSK       | Low     | 1937.50         | 7.83            |
|      |            | Middle  | 1960.00         | 7.89            |
|      |            | High    | 1982.50         | 7.87            |
|      | 16QAM      | Low     | 1937.50         | 7.83            |
|      |            | Middle  | 1960.00         | 7.91            |
|      |            | High    | 1982.50         | 7.90            |
|      | 64QAM      | Low     | 1937.50         | 7.87            |
|      |            | Middle  | 1960.00         | 7.88            |
|      |            | High    | 1982.50         | 7.88            |
|      | 256QAM     | Low     | 1937.50         | 7.85            |
|      |            | Middle  | 1960.00         | 7.93            |
|      |            | High    | 1982.50         | 7.90            |

|   |        |        |         |      |
|---|--------|--------|---------|------|
| 2 | QPSK   | Low    | 1937.50 | 7.87 |
|   |        | Middle | 1960.00 | 7.90 |
|   |        | High   | 1982.50 | 7.90 |
|   | 16QAM  | Low    | 1937.50 | 7.87 |
|   |        | Middle | 1960.00 | 7.93 |
|   |        | High   | 1982.50 | 7.94 |
|   | 64QAM  | Low    | 1937.50 | 7.92 |
|   |        | Middle | 1960.00 | 7.94 |
|   |        | High   | 1982.50 | 7.91 |
|   | 256QAM | Low    | 1937.50 | 7.90 |
|   |        | Middle | 1960.00 | 7.94 |
|   |        | High   | 1982.50 | 7.92 |
| 3 | QPSK   | Low    | 1937.50 | 7.85 |
|   |        | Middle | 1960.00 | 7.93 |
|   |        | High   | 1982.50 | 7.89 |
|   | 16QAM  | Low    | 1937.50 | 7.85 |
|   |        | Middle | 1960.00 | 7.91 |
|   |        | High   | 1982.50 | 7.91 |
|   | 64QAM  | Low    | 1937.50 | 7.93 |
|   |        | Middle | 1960.00 | 7.94 |
|   |        | High   | 1982.50 | 7.90 |
|   | 256QAM | Low    | 1937.50 | 7.91 |
|   |        | Middle | 1960.00 | 7.97 |
|   |        | High   | 1982.50 | 7.94 |

**B2 DSS 15 MHz 5to5 1 Carrier**

| Ant. | Modulation | Channel | Frequency (MHz) | 0.1 % PAPR (dB) |
|------|------------|---------|-----------------|-----------------|
| 0    | QPSK       | Low     | 1937.50         | 7.97            |
|      |            | Middle  | 1960.00         | 7.98            |
|      |            | High    | 1982.50         | 7.99            |
|      | 16QAM      | Low     | 1937.50         | 7.97            |
|      |            | Middle  | 1960.00         | 8.01            |
|      |            | High    | 1982.50         | 7.99            |
|      | 64QAM      | Low     | 1937.50         | 7.98            |
|      |            | Middle  | 1960.00         | 8.00            |
|      |            | High    | 1982.50         | 7.98            |
|      | 256QAM     | Low     | 1937.50         | 7.97            |
|      |            | Middle  | 1960.00         | 8.01            |
|      |            | High    | 1982.50         | 7.99            |
| 1    | QPSK       | Low     | 1937.50         | 8.00            |
|      |            | Middle  | 1960.00         | 7.98            |
|      |            | High    | 1982.50         | 8.00            |
|      | 16QAM      | Low     | 1937.50         | 7.96            |
|      |            | Middle  | 1960.00         | 7.98            |
|      |            | High    | 1982.50         | 7.97            |
|      | 64QAM      | Low     | 1937.50         | 7.97            |
|      |            | Middle  | 1960.00         | 8.01            |
|      |            | High    | 1982.50         | 8.00            |
|      | 256QAM     | Low     | 1937.50         | 7.98            |
|      |            | Middle  | 1960.00         | 8.04            |
|      |            | High    | 1982.50         | 7.99            |

|   |        |        |         |      |
|---|--------|--------|---------|------|
| 2 | QPSK   | Low    | 1937.50 | 8.00 |
|   |        | Middle | 1960.00 | 7.99 |
|   |        | High   | 1982.50 | 8.01 |
|   | 16QAM  | Low    | 1937.50 | 7.96 |
|   |        | Middle | 1960.00 | 7.93 |
|   |        | High   | 1982.50 | 7.99 |
|   | 64QAM  | Low    | 1937.50 | 8.01 |
|   |        | Middle | 1960.00 | 8.05 |
|   |        | High   | 1982.50 | 8.04 |
|   | 256QAM | Low    | 1937.50 | 7.97 |
|   |        | Middle | 1960.00 | 8.07 |
|   |        | High   | 1982.50 | 8.00 |
| 3 | QPSK   | Low    | 1937.50 | 8.00 |
|   |        | Middle | 1960.00 | 8.00 |
|   |        | High   | 1982.50 | 8.01 |
|   | 16QAM  | Low    | 1937.50 | 7.97 |
|   |        | Middle | 1960.00 | 7.99 |
|   |        | High   | 1982.50 | 7.94 |
|   | 64QAM  | Low    | 1937.50 | 8.01 |
|   |        | Middle | 1960.00 | 8.03 |
|   |        | High   | 1982.50 | 8.02 |
|   | 256QAM | Low    | 1937.50 | 7.98 |
|   |        | Middle | 1960.00 | 8.04 |
|   |        | High   | 1982.50 | 8.03 |

**B2 DSS 15 MHz 2to8 1 Carrier**

| Ant. | Modulation | Channel | Frequency (MHz) | 0.1 % PAPR (dB) |
|------|------------|---------|-----------------|-----------------|
| 0    | QPSK       | Low     | 1937.50         | 8.06            |
|      |            | Middle  | 1960.00         | 8.05            |
|      |            | High    | 1982.50         | 8.04            |
|      | 16QAM      | Low     | 1937.50         | 8.00            |
|      |            | Middle  | 1960.00         | 8.03            |
|      |            | High    | 1982.50         | 8.08            |
|      | 64QAM      | Low     | 1937.50         | 8.02            |
|      |            | Middle  | 1960.00         | 8.07            |
|      |            | High    | 1982.50         | 8.06            |
|      | 256QAM     | Low     | 1937.50         | 8.06            |
|      |            | Middle  | 1960.00         | 8.08            |
|      |            | High    | 1982.50         | 8.07            |
| 1    | QPSK       | Low     | 1937.50         | 8.05            |
|      |            | Middle  | 1960.00         | 8.04            |
|      |            | High    | 1982.50         | 8.09            |
|      | 16QAM      | Low     | 1937.50         | 8.01            |
|      |            | Middle  | 1960.00         | 8.05            |
|      |            | High    | 1982.50         | 8.05            |
|      | 64QAM      | Low     | 1937.50         | 8.05            |
|      |            | Middle  | 1960.00         | 8.07            |
|      |            | High    | 1982.50         | 8.06            |
|      | 256QAM     | Low     | 1937.50         | 8.09            |
|      |            | Middle  | 1960.00         | 8.08            |
|      |            | High    | 1982.50         | 8.08            |

|   |        |        |         |      |
|---|--------|--------|---------|------|
| 2 | QPSK   | Low    | 1937.50 | 8.07 |
|   |        | Middle | 1960.00 | 8.09 |
|   |        | High   | 1982.50 | 8.10 |
|   | 16QAM  | Low    | 1937.50 | 8.04 |
|   |        | Middle | 1960.00 | 8.10 |
|   |        | High   | 1982.50 | 8.06 |
|   | 64QAM  | Low    | 1937.50 | 8.07 |
|   |        | Middle | 1960.00 | 8.14 |
|   |        | High   | 1982.50 | 8.08 |
|   | 256QAM | Low    | 1937.50 | 8.04 |
|   |        | Middle | 1960.00 | 8.10 |
|   |        | High   | 1982.50 | 8.08 |
| 3 | QPSK   | Low    | 1937.50 | 8.06 |
|   |        | Middle | 1960.00 | 8.09 |
|   |        | High   | 1982.50 | 8.08 |
|   | 16QAM  | Low    | 1937.50 | 8.03 |
|   |        | Middle | 1960.00 | 8.08 |
|   |        | High   | 1982.50 | 8.04 |
|   | 64QAM  | Low    | 1937.50 | 8.05 |
|   |        | Middle | 1960.00 | 8.11 |
|   |        | High   | 1982.50 | 8.08 |
|   | 256QAM | Low    | 1937.50 | 8.07 |
|   |        | Middle | 1960.00 | 8.08 |
|   |        | High   | 1982.50 | 8.08 |

**LTE B2 5 MHz 1 Carrier**

| Ant. | Modulation | Channel | Frequency (MHz) | 0.1 % PAPR (dB) |
|------|------------|---------|-----------------|-----------------|
| 0    | QPSK       | High    | 1987.50         | 8.34            |

**LTE B2 10 MHz 1 Carrier**

| Ant. | Modulation | Channel | Frequency (MHz) | 0.1 % PAPR (dB) |
|------|------------|---------|-----------------|-----------------|
| 1    | 16QAM      | High    | 1985.00         | 7.77            |

**LTE B2 15 MHz 1 Carrier**

| Ant. | Modulation | Channel | Frequency (MHz) | 0.1 % PAPR (dB) |
|------|------------|---------|-----------------|-----------------|
| 1    | 256QAM     | High    | 1982.50         | 7.88            |

**LTE B2 20 MHz 1 Carrier**

| Ant. | Modulation | Channel | Frequency (MHz) | 0.1 % PAPR (dB) |
|------|------------|---------|-----------------|-----------------|
| 1    | 16QAM      | High    | 1980.00         | 7.89            |

## Plot Data of PAPR

## Antenna 0 / B2 DSS 15 MHz 9to1 1 Carrier / 256QAM / Low

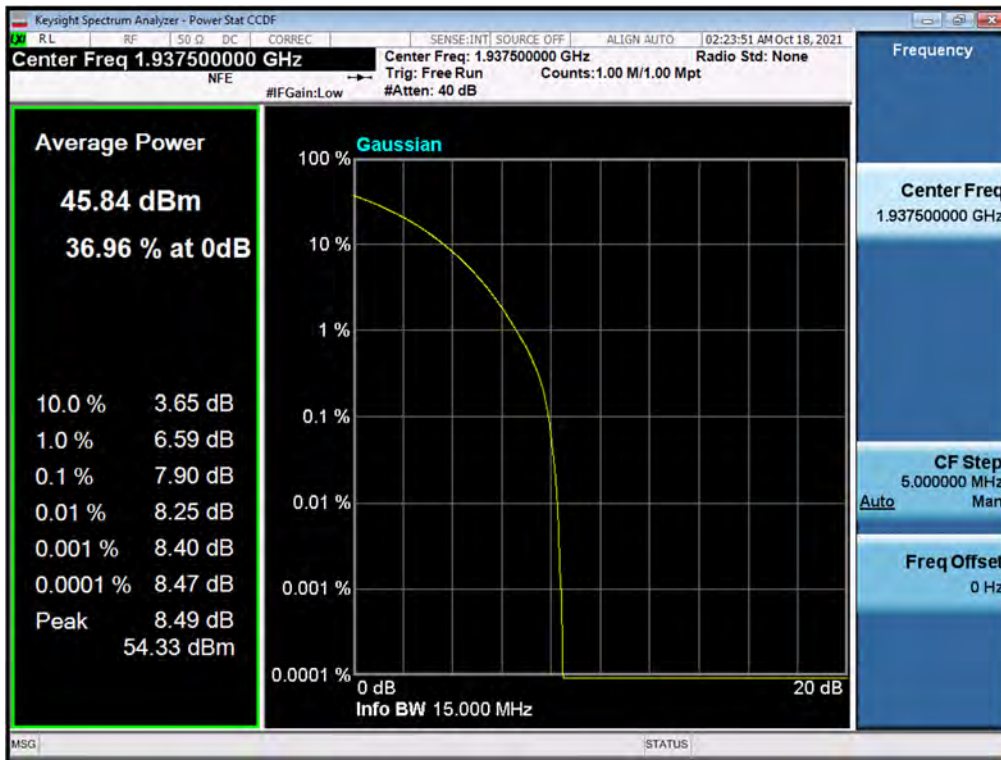

## Antenna 1 / B2 DSS 15 MHz 5to5 1 Carrier / 64QAM / Low

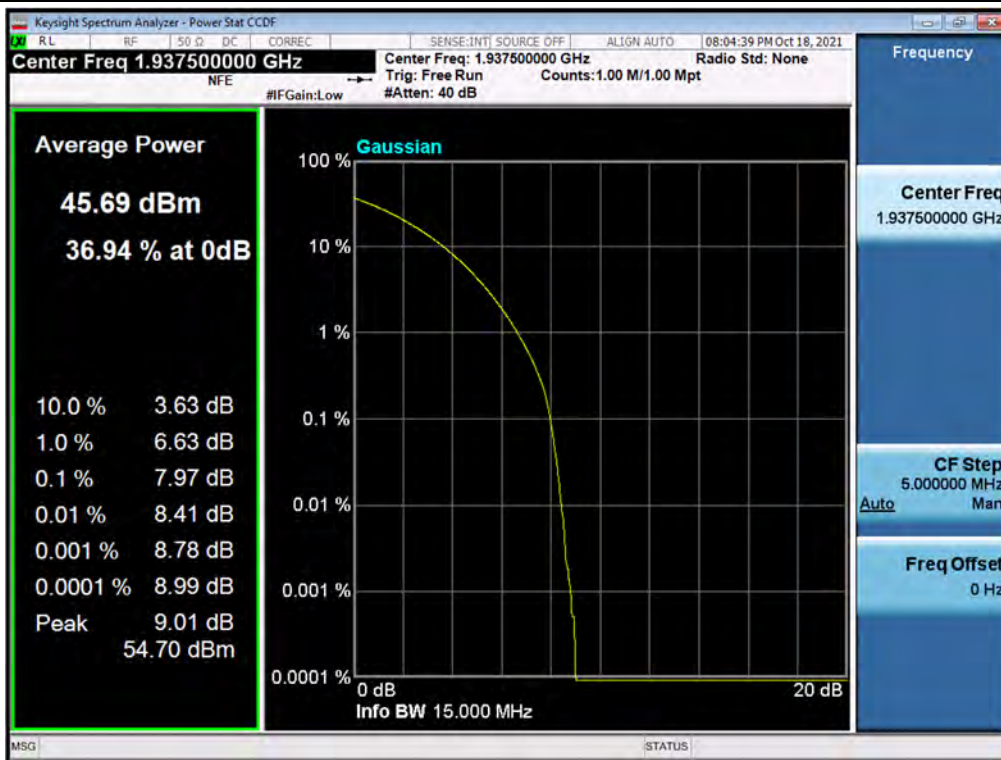



Antenna 0 / B2 DSS 15 MHz 2to8 1 Carrier / 64QAM / Low

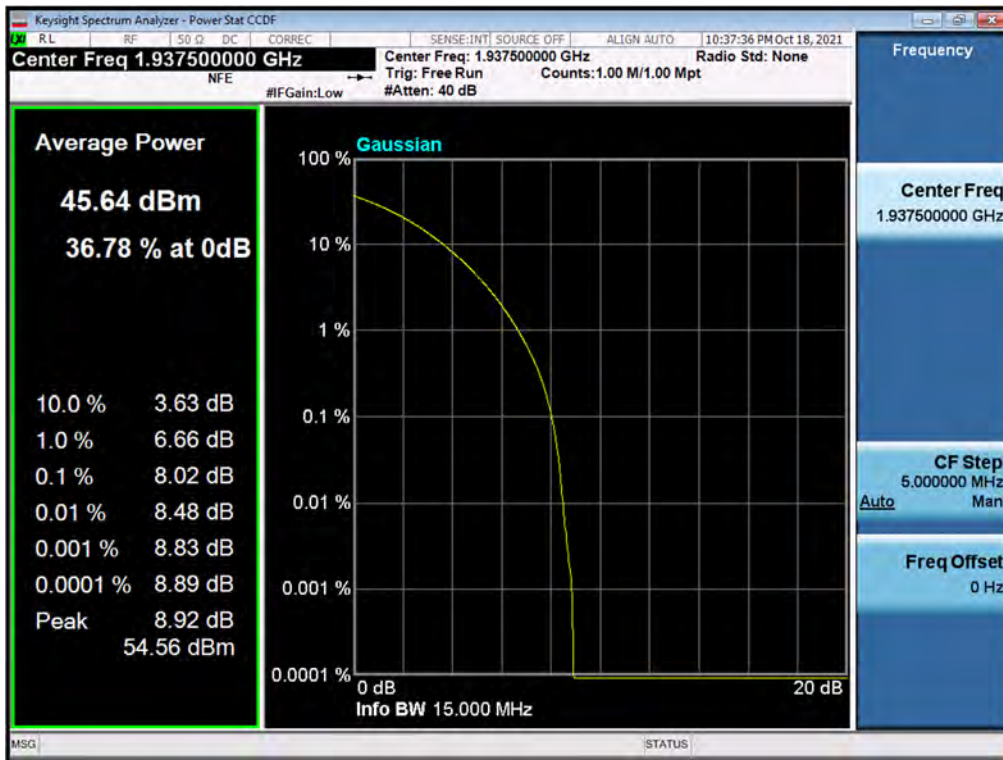

Antenna 1 / LTE B2 20 MHz 1 Carrier / 16QAM / High



### 5.3. OCCUPIED BANDWIDTH

#### Test Requirements:

##### § 2.1049 Measurements required: Occupied bandwidth.

The occupied bandwidth, that is the frequency bandwidth such that, below its lower and above its upper frequency limits, the mean powers radiated are each equal to 0.5 percent of the total mean power radiated by a given emission shall be measured under the specified conditions of § 2.1049 (a) through (i) as applicable.

#### Test Procedures:

The measurement is performed in accordance with Section 5.4.3 and 5.4.4 of ANSI C63.26.

##### 5.4.3 Occupied bandwidth—Relative measurement procedure

The OBW is measured as the width of the spectral envelope of the modulated signal, at an amplitude level reduced from a reference value by a specified ratio (or in decibels, a specified number of dB down from the reference value). The typical ratio for transmitters is  $-26$  dB, corresponding to the 26 dB BW; however, other ratios can be specified. In this subclause, the ratio is designated by “ $-X$  dB.”

- a) The spectrum analyzer center frequency is set to the nominal EUT channel center frequency. The span range for the spectrum analyzer shall be wide enough to see sufficient roll off of the signal to make the measurement.
- b) The nominal RBW shall be in the range of 1% to 5% of the anticipated OBW, and the VBW shall be set  $\geq 3 \times$  RBW.
- c) Set the reference level of the instrument as required to prevent the signal amplitude from exceeding the maximum spectrum analyzer input mixer level for linear operation. See guidance provided in 4.2.3.

NOTE—Step a), step b), and step c) may require iteration to adjust within the specified tolerances.

- d) The dynamic range of the spectrum analyzer at the selected RBW shall be more than 10 dB below the target “ $-X$  dB” requirement, i.e., if the requirement calls for measuring the  $-26$  dB OBW, the spectrum analyzer noise floor at the selected RBW shall be at least 36 dB below the reference level.
- e) Set spectrum analyzer detection mode to peak, and the trace mode to max hold.
- f) Determine the reference value by either of the following:
  - 1) Set the EUT to transmit a modulated signal. Allow the trace to stabilize. Set the spectrum analyzer marker to the Highest level of the displayed trace (this is the reference value).
  - 2) Set the EUT to transmit an unmodulated carrier. Set the spectrum analyzer marker to the level of the carrier.
- g) Determine the “ $-X$  dB amplitude” as equal to (Reference Value  $- X$ ). Alternatively, this calculation can be performed on the spectrum analyzer using the delta-marker measurement function.
- h) If the reference value was determined using an unmodulated carrier, turn the EUT modulation on, then either clear the existing trace or start a new trace on the spectrum analyzer and allow the new trace to stabilize. Otherwise the trace from step f) shall be used for step i).
- i) Place two markers, one at the lowest and the other at the Highest frequency of the envelope of the spectral display such that each marker is at or slightly below the “ $-X$  dB amplitude” determined in step f). If a marker is below this “ $-X$  dB amplitude” value it should be as close as possible to this value. The OBW is the positive frequency difference between the two markers. The spectral envelope can cross the “ $-X$  dB amplitude” at multiple points. The lowest or Highest frequency

shall be selected as the frequencies that are the farthest away from the center frequency at which the spectral envelope crosses the “-X dB amplitude.”

- j) The OBW shall be reported by providing plot(s) of the measuring instrument display, to include markers depicting the relevant frequency and amplitude information (e.g., marker table). The frequency and amplitude axis and scale shall be clearly labeled. Tabular data may be reported in addition to the plot(s).

#### 5.4.4 Occupied bandwidth—Power bandwidth (99%) measurement procedure

The OBW is the frequency bandwidth such that, below its lower and above its upper frequency limits, the mean powers are each equal to 0.5% of the total mean power of the given emission.

The following procedure shall be used for measuring (99%) power bandwidth:

- a) The spectrum analyzer center frequency is set to the nominal EUT channel center frequency. The frequency span for the spectrum analyzer shall be set wide enough to capture all modulation products including the emission skirts (typically a span of  $1.5 \times \text{OBW}$  is sufficient).
- b) The nominal IF filter 3 dB bandwidth (RBW) shall be in the range of 1% to 5% of the anticipated OBW, and the VBW shall be set  $\geq 3 \times \text{RBW}$ .
- c) Set the reference level of the instrument as required to prevent the signal amplitude from exceeding the maximum spectrum analyzer input mixer level for linear operation. See guidance provided in 4.2.3.  
NOTE—Step a), step b), and step c) may require iteration to adjust within the specified tolerances.
- d) Set the detection mode to peak, and the trace mode to max-hold.
- e) If the instrument does not have a 99% OBW function, recover the trace data points and sum directly in linear power terms. Place the recovered amplitude data points, beginning at the lowest frequency, in a running sum until 0.5% of the total is reached. Record that frequency as the lower OBW frequency. Repeat the process until 99.5% of the total is reached and record that frequency as the upper OBW frequency. The 99% power OBW can be determined by computing the difference these two frequencies.
- f) The OBW shall be reported and plot(s) of the measuring instrument display shall be provided with the test report. The frequency and amplitude axis and scale shall be clearly labeled. Tabular data can be reported in addition to the plot(s).

**Note:** The results of the Occupied Bandwidth test shown above the frequency measured values are very small and similar trend for each port, so we are attached only the worst case plot.

**Test Results:  
Tabular Data of Occupied Bandwidth**
**B2 DSS 15 MHz 9to1 1 Carrier**

| Ant | Mod    | Channel | Frequency (MHz) | Occupied Bandwidth (MHz) |
|-----|--------|---------|-----------------|--------------------------|
| 0   | QPSK   | Low     | 1937.50         | 13.982                   |
|     |        | Middle  | 1960.00         | 14.005                   |
|     |        | High    | 1982.50         | 13.969                   |
|     | 16QAM  | Low     | 1937.50         | 14.012                   |
|     |        | Middle  | 1960.00         | 14.081                   |
|     |        | High    | 1982.50         | 14.023                   |
|     | 64QAM  | Low     | 1937.50         | 13.789                   |
|     |        | Middle  | 1960.00         | 13.919                   |
|     |        | High    | 1982.50         | 13.972                   |
|     | 256QAM | Low     | 1937.50         | 13.859                   |
|     |        | Middle  | 1960.00         | 13.959                   |
|     |        | High    | 1982.50         | 13.763                   |
| 1   | QPSK   | Low     | 1937.50         | 13.999                   |
|     |        | Middle  | 1960.00         | 13.933                   |
|     |        | High    | 1982.50         | 13.879                   |
|     | 16QAM  | Low     | 1937.50         | 14.006                   |
|     |        | Middle  | 1960.00         | 13.971                   |
|     |        | High    | 1982.50         | 14.017                   |
|     | 64QAM  | Low     | 1937.50         | 13.873                   |
|     |        | Middle  | 1960.00         | 13.998                   |
|     |        | High    | 1982.50         | 13.920                   |
|     | 256QAM | Low     | 1937.50         | 13.903                   |
|     |        | Middle  | 1960.00         | 13.944                   |
|     |        | High    | 1982.50         | 13.867                   |

|        |        |         |         |        |
|--------|--------|---------|---------|--------|
| 2      | QPSK   | Low     | 1937.50 | 13.988 |
|        |        | Middle  | 1960.00 | 14.013 |
|        |        | High    | 1982.50 | 14.011 |
|        | 16QAM  | Low     | 1937.50 | 14.000 |
|        |        | Middle  | 1960.00 | 13.976 |
|        |        | High    | 1982.50 | 13.886 |
|        | 64QAM  | Low     | 1937.50 | 13.991 |
|        |        | Middle  | 1960.00 | 13.913 |
|        |        | High    | 1982.50 | 13.952 |
| 256QAM | Low    | 1937.50 | 13.872  |        |
|        | Middle | 1960.00 | 13.898  |        |
|        | High   | 1982.50 | 13.932  |        |
| 3      | QPSK   | Low     | 1937.50 | 13.921 |
|        |        | Middle  | 1960.00 | 13.925 |
|        |        | High    | 1982.50 | 13.934 |
|        | 16QAM  | Low     | 1937.50 | 14.065 |
|        |        | Middle  | 1960.00 | 14.082 |
|        |        | High    | 1982.50 | 14.073 |
|        | 64QAM  | Low     | 1937.50 | 13.983 |
|        |        | Middle  | 1960.00 | 13.868 |
|        |        | High    | 1982.50 | 13.898 |
| 256QAM | Low    | 1937.50 | 13.962  |        |
|        | Middle | 1960.00 | 13.951  |        |
|        | High   | 1982.50 | 13.950  |        |

## B2 DSS 15 MHz 5to5 1 Carrier

| Ant | Mod    | Channel | Frequency (MHz) | Occupied Bandwidth (MHz) |
|-----|--------|---------|-----------------|--------------------------|
| 0   | QPSK   | Low     | 1937.50         | 14.107                   |
|     |        | Middle  | 1960.00         | 14.080                   |
|     |        | High    | 1982.50         | 14.137                   |
|     | 16QAM  | Low     | 1937.50         | 14.132                   |
|     |        | Middle  | 1960.00         | 14.159                   |
|     |        | High    | 1982.50         | 14.175                   |
|     | 64QAM  | Low     | 1937.50         | 14.036                   |
|     |        | Middle  | 1960.00         | 14.087                   |
|     |        | High    | 1982.50         | 14.064                   |
|     | 256QAM | Low     | 1937.50         | 14.010                   |
|     |        | Middle  | 1960.00         | 14.058                   |
|     |        | High    | 1982.50         | 14.064                   |
| 1   | QPSK   | Low     | 1937.50         | 14.100                   |
|     |        | Middle  | 1960.00         | 14.082                   |
|     |        | High    | 1982.50         | 14.043                   |
|     | 16QAM  | Low     | 1937.50         | 14.114                   |
|     |        | Middle  | 1960.00         | 14.124                   |
|     |        | High    | 1982.50         | 14.149                   |
|     | 64QAM  | Low     | 1937.50         | 14.118                   |
|     |        | Middle  | 1960.00         | 14.132                   |
|     |        | High    | 1982.50         | 14.105                   |
|     | 256QAM | Low     | 1937.50         | 14.042                   |
|     |        | Middle  | 1960.00         | 14.079                   |
|     |        | High    | 1982.50         | 14.119                   |

|   |        |        |         |        |
|---|--------|--------|---------|--------|
| 2 | QPSK   | Low    | 1937.50 | 14.066 |
|   |        | Middle | 1960.00 | 14.145 |
|   |        | High   | 1982.50 | 14.091 |
|   | 16QAM  | Low    | 1937.50 | 14.131 |
|   |        | Middle | 1960.00 | 14.115 |
|   |        | High   | 1982.50 | 14.180 |
|   | 64QAM  | Low    | 1937.50 | 14.073 |
|   |        | Middle | 1960.00 | 14.058 |
|   |        | High   | 1982.50 | 14.093 |
|   | 256QAM | Low    | 1937.50 | 14.121 |
|   |        | Middle | 1960.00 | 14.075 |
|   |        | High   | 1982.50 | 14.070 |
| 3 | QPSK   | Low    | 1937.50 | 14.086 |
|   |        | Middle | 1960.00 | 14.135 |
|   |        | High   | 1982.50 | 14.134 |
|   | 16QAM  | Low    | 1937.50 | 14.129 |
|   |        | Middle | 1960.00 | 14.178 |
|   |        | High   | 1982.50 | 14.128 |
|   | 64QAM  | Low    | 1937.50 | 14.029 |
|   |        | Middle | 1960.00 | 14.084 |
|   |        | High   | 1982.50 | 14.107 |
|   | 256QAM | Low    | 1937.50 | 14.068 |
|   |        | Middle | 1960.00 | 14.064 |
|   |        | High   | 1982.50 | 14.093 |

**B2 DSS 15 MHz 2to8 1 Carrier**

| Ant | Mod    | Channel | Frequency (MHz) | Occupied Bandwidth (MHz) |
|-----|--------|---------|-----------------|--------------------------|
| 0   | QPSK   | Low     | 1937.50         | 14.129                   |
|     |        | Middle  | 1960.00         | 14.118                   |
|     |        | High    | 1982.50         | 14.141                   |
|     | 16QAM  | Low     | 1937.50         | 14.186                   |
|     |        | Middle  | 1960.00         | 14.155                   |
|     |        | High    | 1982.50         | 14.172                   |
|     | 64QAM  | Low     | 1937.50         | 14.094                   |
|     |        | Middle  | 1960.00         | 14.125                   |
|     |        | High    | 1982.50         | 14.128                   |
|     | 256QAM | Low     | 1937.50         | 14.104                   |
|     |        | Middle  | 1960.00         | 14.126                   |
|     |        | High    | 1982.50         | 14.130                   |
| 1   | QPSK   | Low     | 1937.50         | 14.125                   |
|     |        | Middle  | 1960.00         | 14.139                   |
|     |        | High    | 1982.50         | 14.154                   |
|     | 16QAM  | Low     | 1937.50         | 14.186                   |
|     |        | Middle  | 1960.00         | 14.172                   |
|     |        | High    | 1982.50         | 14.140                   |
|     | 64QAM  | Low     | 1937.50         | 14.111                   |
|     |        | Middle  | 1960.00         | 14.152                   |
|     |        | High    | 1982.50         | 14.094                   |
|     | 256QAM | Low     | 1937.50         | 14.105                   |
|     |        | Middle  | 1960.00         | 14.082                   |
|     |        | High    | 1982.50         | 14.094                   |



|   |        |        |         |        |
|---|--------|--------|---------|--------|
| 2 | QPSK   | Low    | 1937.50 | 14.126 |
|   |        | Middle | 1960.00 | 14.141 |
|   |        | High   | 1982.50 | 14.120 |
|   | 16QAM  | Low    | 1937.50 | 14.164 |
|   |        | Middle | 1960.00 | 14.197 |
|   |        | High   | 1982.50 | 14.180 |
|   | 64QAM  | Low    | 1937.50 | 14.164 |
|   |        | Middle | 1960.00 | 14.120 |
|   |        | High   | 1982.50 | 14.104 |
|   | 256QAM | Low    | 1937.50 | 14.129 |
|   |        | Middle | 1960.00 | 14.109 |
|   |        | High   | 1982.50 | 14.123 |
| 3 | QPSK   | Low    | 1937.50 | 14.159 |
|   |        | Middle | 1960.00 | 14.147 |
|   |        | High   | 1982.50 | 14.118 |
|   | 16QAM  | Low    | 1937.50 | 14.128 |
|   |        | Middle | 1960.00 | 14.182 |
|   |        | High   | 1982.50 | 14.158 |
|   | 64QAM  | Low    | 1937.50 | 14.128 |
|   |        | Middle | 1960.00 | 14.120 |
|   |        | High   | 1982.50 | 14.122 |
|   | 256QAM | Low    | 1937.50 | 14.093 |
|   |        | Middle | 1960.00 | 14.111 |
|   |        | High   | 1982.50 | 14.108 |

**LTE B2 5 MHz 1 Carrier**

| Ant | Mod  | Channel | Frequency (MHz) | Occupied Bandwidth (MHz) |
|-----|------|---------|-----------------|--------------------------|
| 0   | QPSK | High    | 1987.50         | 4.5130                   |

**LTE B2 10 MHz 1 Carrier**

| Ant | Mod   | Channel | Frequency (MHz) | Occupied Bandwidth (MHz) |
|-----|-------|---------|-----------------|--------------------------|
| 1   | 16QAM | High    | 1985.00         | 8.9883                   |

**LTE B2 15 MHz 1 Carrier**

| Ant | Mod    | Channel | Frequency (MHz) | Occupied Bandwidth (MHz) |
|-----|--------|---------|-----------------|--------------------------|
| 1   | 256QAM | High    | 1982.50         | 13.514                   |

**LTE B2 20 MHz 1 Carrier**

| Ant | Mod   | Channel | Frequency (MHz) | Occupied Bandwidth (MHz) |
|-----|-------|---------|-----------------|--------------------------|
| 1   | 16QAM | High    | 1980.00         | 17.973                   |

## Plot Data of Occupied bandwidth

## Antenna 0 / B2 DSS 15 MHz 9to1 1 Carrier / 256QAM / Low

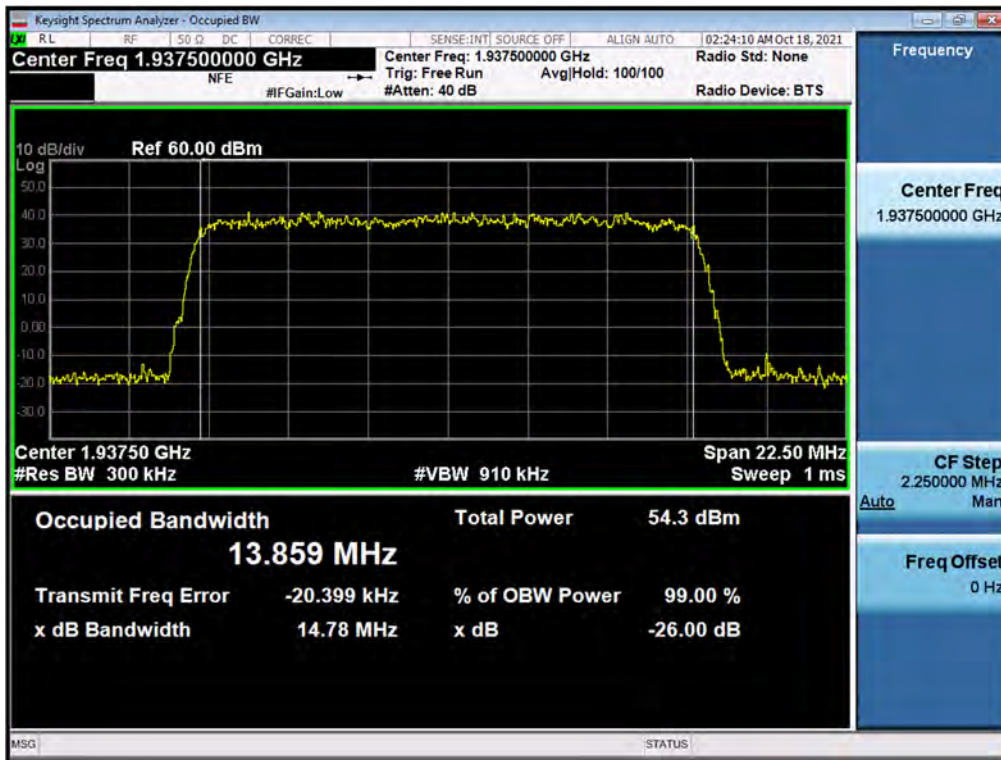

## Antenna 1 / B2 DSS 15 MHz 5to5 1 Carrier / 64QAM / Low

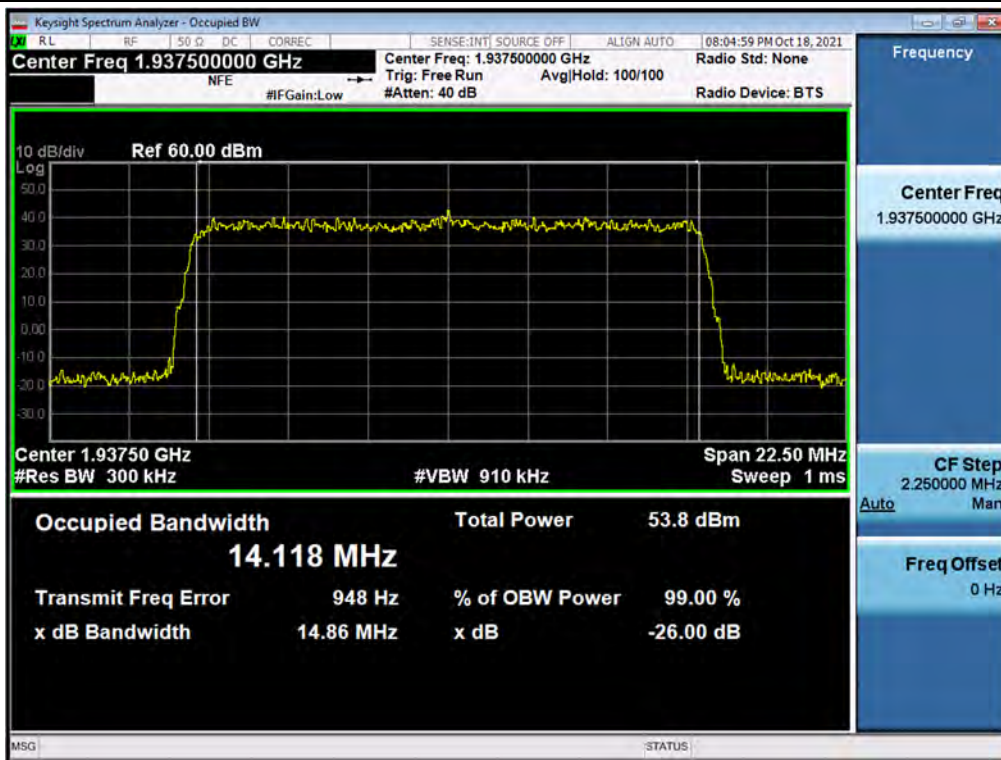

Antenna 0 / B2 DSS 15 MHz 2to8 1 Carrier / 64QAM / Low

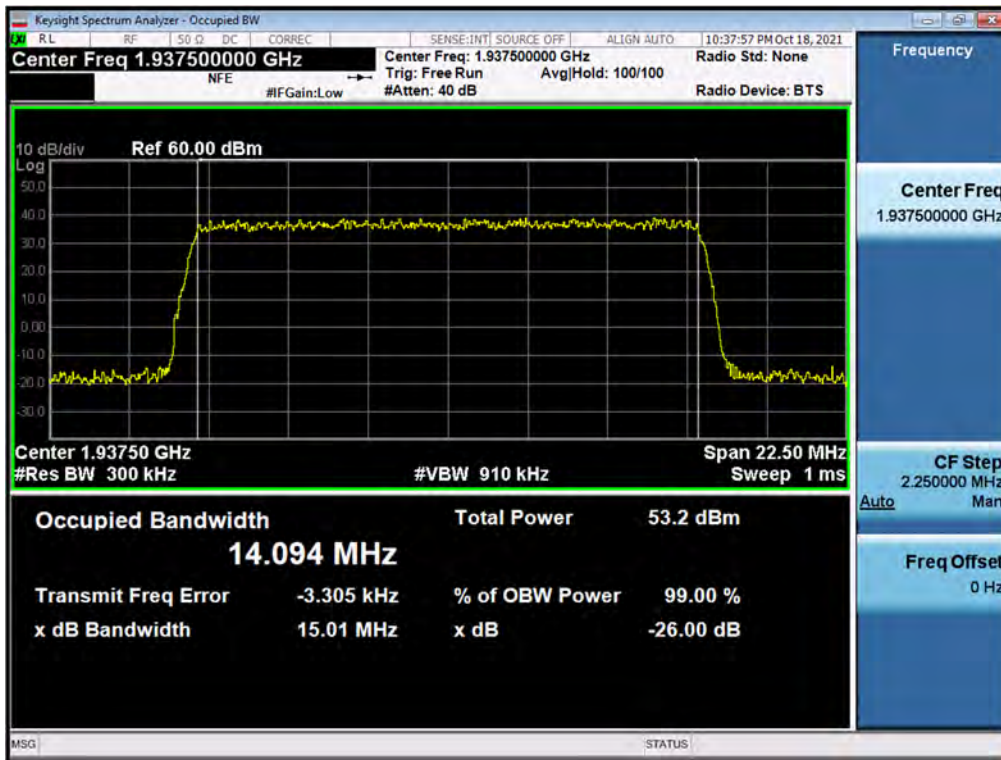

Antenna 1 / LTE B2 20 MHz 1 Carrier / 16QAM / High

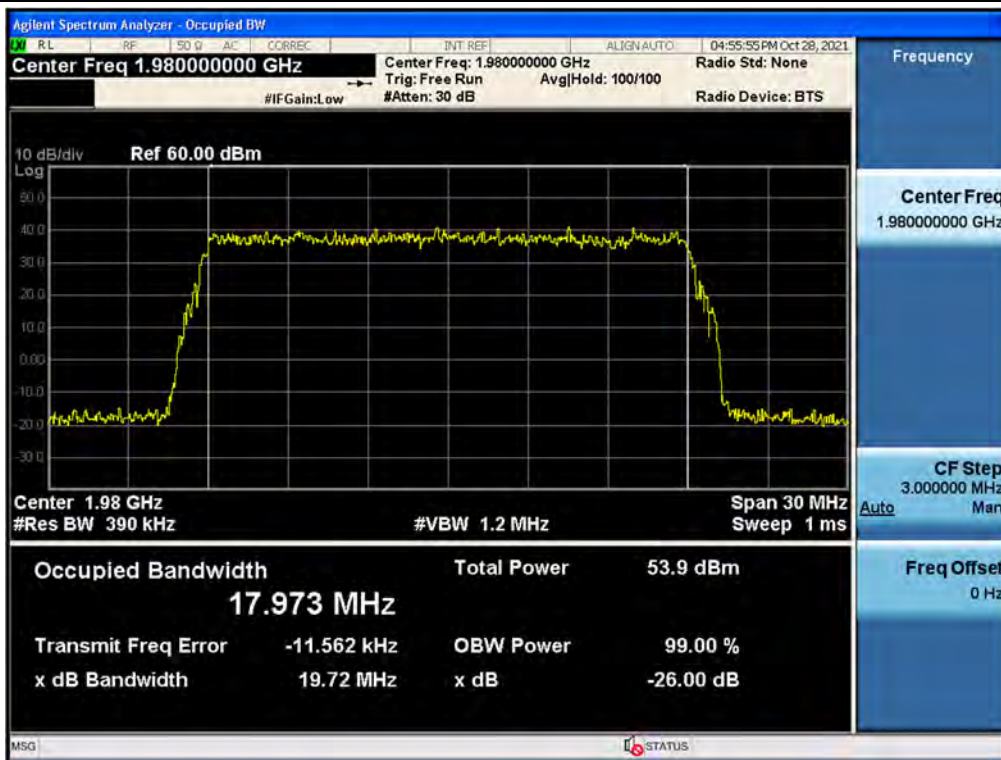

## 5.4. OUT-OF-BAND UNWANTED EMISSIONS

### Test Requirements:

#### § 2.1051 Measurements required: Spurious emissions at antenna terminals.

The radio frequency voltage or powers generated within the equipment and appearing on a spurious frequency shall be checked at the equipment output terminals when properly loaded with a suitable artificial antenna. Curves or equivalent data shall show the magnitude of each harmonic and other spurious emission that can be detected when the equipment is operated under the conditions specified in § 2.1049 as appropriate. The magnitude of spurious emissions which are attenuated more than 20 dB below the permissible value need not be specified.

#### § 24.238 Emission limitations for Broadband PCS equipment.

The rules in this section govern the spectral characteristics of emissions in the Broadband Personal Communications Service.

- (a) Out of band emissions. The power of any emission outside of the authorized operating frequency ranges must be attenuated below the transmitting power (P) by a factor of at least  $43 + 10 \log(P)$  dB.
- (b) Measurement procedure. Compliance with these rules is based on the use of measurement instrumentation employing a resolution bandwidth of 1 MHz or greater. However, in the 1 MHz bands immediately outside and adjacent to the frequency block a resolution bandwidth of at least one percent of the emission bandwidth of the fundamental emission of the transmitter may be employed. A narrower resolution bandwidth is permitted in all cases to improve measurement accuracy provided the measured power is integrated over the full required measurement bandwidth (i.e. 1 MHz or 1 percent of emission bandwidth, as specified). The emission bandwidth is defined as the width of the signal between two points, one below the carrier center frequency and one above the carrier center frequency, outside of which all emissions are attenuated at least 26 dB below the transmitter power.
- (c) Alternative out of band emission limit. Licensees in this service may establish an alternative out of band emission limit to be used at specified band edge(s) in specified geographical areas, in lieu of that set forth in this section, pursuant to a private contractual arrangement of all affected licensees and applicants. In this event, each party to such contract shall maintain a copy of the contract in their station files and disclose it to prospective assignees or transferees and, upon request, to the FCC.
- (d) Interference caused by out of band emissions. If any emission from a transmitter operating in this service results in interference to users of another radio service, the FCC may require a greater attenuation of that emission than

### Test Procedures:

The measurement is performed in accordance with Section 5.7.3 of ANSI C63.26.

#### 5.7.3 Out-of-band unwanted emissions measurements

- a) Set the spectrum analyzer center frequency to the block, band, or channel edge frequency.
- b) Set the span wide enough to capture the fundamental emission closest to the authorized block or band edge, and to include all modulation products that spill into the immediately adjacent frequency band. In some cases, it may be possible to set the center frequency and span so as to encompass the fundamental emission and the unwanted out-of-band (band-edge) emissions on either side of the authorized block, band, or channel. This can be accomplished with a single (slow) sweep, if adequate overload protection and sufficient dynamic range can be maintained.

- c) Set the number of points in sweep  $\geq 2 \times \text{span} / \text{RBW}$ .
- d) Sweep time should be auto for peak detection. For rms detection the sweep time should be set as follows:
  - 1) If the device can be configured to transmit continuously (duty cycle  $\geq 98\%$ ), set the (sweep time)  $>$  (number of points in sweep)  $\times$  (symbol period) (e.g., by a factor of  $10 \times \text{symbol period} \times \text{number of points}$ ). Increasing the sweep time (i.e., slowing the sweep speed) will allow for averaging over multiple symbols
  - 2) If the device cannot be configured to transmit continuously (duty cycle  $< 98\%$ ) and a freerunning sweep must be used, set the sweep time so that the averaging is performed over multiple on/off cycles by setting the sweep time  $>$  (number of points in sweep)  $\times$  (transmitter period) (i.e., the transmit on-time + the off-time). The spectrum analyzer readings shall subsequently be corrected by  $[10 \log (1/\text{duty cycle})]$ . This assumes that the transmission period and duty cycle is relatively constant (duty cycle variation  $\leq \pm 2\%$ ).
  - 3) If the device cannot be configured to transmit continuously (duty cycle  $< 98\%$ ) and a freerunning sweep must be used, set the sweep time so that the averaging is performed over multiple on/off cycles by setting the sweep time  $>$  (number of points in sweep)  $\times$  (transmitter period) (i.e., the transmit on-time + the off-time). The spectrum analyzer readings shall subsequently be corrected by  $[10 \log (1/\text{duty cycle})]$ . This assumes that the transmission period and duty cycle is relatively constant (duty cycle variation  $\leq \pm 2\%$ ).
  - 4) If the device cannot be configured to transmit continuously and a free-running sweep must be used, and if the transmissions exhibit a non-constant duty cycle (duty cycle variations  $> \pm 2\%$ ), set the sweep time so that the averaging is performed over the on-period by setting the sweep time  $>$  (symbol period)  $\times$  (number of points), while also maintaining the sweep time  $<$  (transmitter on-time). The trace mode shall be set to max hold, since not every display point will be averaged only over just the on-time. Thus, multiple sweeps (e.g., 100) in maximum hold are necessary to ensure that the maximum power is measured.
- e) The test report shall include the plots of the measuring instrument display and the measured data.
- f) See Annex I for example emission mask plots.

**Note:**

- 1. Due to MIMO operations, a correction has been added to the limit according to KDB 662911 D01 v02r01.
  - 4Tx MIMO correction:  $10 \log(N_{\text{ANT}}) = 10 \log(4) = 6.02 \text{ dB} // -13 \text{ dBm} - 10 \cdot \log(4) = -19.02 \text{ dBm}$
- 2. The results of the Out-of-band Unwanted Emissions test shown above the frequency measured values are very small and similar trend for each port, so we are attached only the worst case plot.

**Test Results:**
**Tabular Data of Out-of-band Unwanted Emissions**
**B2 DSS 15 MHz 9to1 1 Carrier**

| Ant. | Mod.   | Channel | Frequency (MHz) | Measured Value (dBm) |
|------|--------|---------|-----------------|----------------------|
| 0    | QPSK   | Low     | 1929.93         | -22.46               |
|      |        | High    | 1990.08         | -21.90               |
|      | 16QAM  | Low     | 1929.93         | -21.56               |
|      |        | High    | 1990.08         | -21.15               |
|      | 64QAM  | Low     | 1929.93         | -21.82               |
|      |        | High    | 1990.08         | -21.12               |
|      | 256QAM | Low     | 1929.93         | -21.24               |
|      |        | High    | 1990.08         | -25.52               |
| 1    | QPSK   | Low     | 1929.93         | -21.69               |
|      |        | High    | 1990.08         | -22.61               |
|      | 16QAM  | Low     | 1929.93         | -21.75               |
|      |        | High    | 1990.08         | -22.40               |
|      | 64QAM  | Low     | 1929.93         | -22.70               |
|      |        | High    | 1990.08         | -21.76               |
|      | 256QAM | Low     | 1929.93         | -23.03               |
|      |        | High    | 1990.08         | -23.75               |
| 2    | QPSK   | Low     | 1929.93         | -22.20               |
|      |        | High    | 1990.08         | -23.48               |
|      | 16QAM  | Low     | 1929.93         | -21.98               |
|      |        | High    | 1990.08         | -21.01               |
|      | 64QAM  | Low     | 1929.93         | -22.92               |
|      |        | High    | 1990.08         | -27.43               |
|      | 256QAM | Low     | 1929.93         | -21.48               |
|      |        | High    | 1990.08         | -21.55               |
| 3    | QPSK   | Low     | 1929.93         | -21.42               |
|      |        | High    | 1990.08         | -24.40               |
|      | 16QAM  | Low     | 1929.93         | -21.55               |
|      |        | High    | 1990.08         | -22.62               |
|      | 64QAM  | Low     | 1929.93         | -21.90               |
|      |        | High    | 1990.08         | -23.47               |
|      | 256QAM | Low     | 1929.93         | -23.35               |
|      |        | High    | 1990.08         | -25.91               |

**B2 DSS 15 MHz 5to5 1 Carrier**

| Ant. | Mod.   | Channel | Frequency (MHz) | Measured Value (dBm) |
|------|--------|---------|-----------------|----------------------|
| 0    | QPSK   | Low     | 1929.93         | -22.05               |
|      |        | High    | 1990.08         | -25.06               |
|      | 16QAM  | Low     | 1929.93         | -21.78               |
|      |        | High    | 1990.08         | -21.41               |
|      | 64QAM  | Low     | 1929.93         | -21.72               |
|      |        | High    | 1990.08         | -21.55               |
|      | 256QAM | Low     | 1929.93         | -20.53               |
|      |        | High    | 1990.08         | -21.35               |
| 1    | QPSK   | Low     | 1929.93         | -22.59               |
|      |        | High    | 1990.08         | -24.62               |
|      | 16QAM  | Low     | 1929.93         | -22.07               |
|      |        | High    | 1990.08         | -22.36               |
|      | 64QAM  | Low     | 1929.93         | -20.57               |
|      |        | High    | 1990.08         | -24.11               |
|      | 256QAM | Low     | 1929.93         | -21.12               |
|      |        | High    | 1990.08         | -22.33               |
| 2    | QPSK   | Low     | 1929.93         | -20.99               |
|      |        | High    | 1990.08         | -22.19               |
|      | 16QAM  | Low     | 1929.93         | -21.10               |
|      |        | High    | 1990.08         | -21.52               |
|      | 64QAM  | Low     | 1929.93         | -20.83               |
|      |        | High    | 1990.08         | -22.39               |
|      | 256QAM | Low     | 1929.93         | -21.45               |
|      |        | High    | 1990.08         | -23.57               |
| 3    | QPSK   | Low     | 1929.93         | -22.70               |
|      |        | High    | 1990.08         | -24.18               |
|      | 16QAM  | Low     | 1929.93         | -21.43               |
|      |        | High    | 1990.08         | -21.60               |
|      | 64QAM  | Low     | 1929.93         | -21.92               |
|      |        | High    | 1990.08         | -24.28               |
|      | 256QAM | Low     | 1929.93         | -22.61               |
|      |        | High    | 1990.08         | -22.60               |



**B2 DSS 15 MHz 2to8 1 Carrier**

| Ant. | Mod.   | Channel | Frequency (MHz) | Measured Value (dBm) |
|------|--------|---------|-----------------|----------------------|
| 0    | QPSK   | Low     | 1929.93         | -21.33               |
|      |        | High    | 1990.08         | -21.81               |
|      | 16QAM  | Low     | 1929.93         | -21.21               |
|      |        | High    | 1990.08         | -21.13               |
|      | 64QAM  | Low     | 1929.93         | -21.52               |
|      |        | High    | 1990.08         | -23.76               |
|      | 256QAM | Low     | 1929.93         | -23.46               |
|      |        | High    | 1990.08         | -23.55               |
| 1    | QPSK   | Low     | 1929.93         | -22.60               |
|      |        | High    | 1990.08         | -21.62               |
|      | 16QAM  | Low     | 1929.93         | -23.29               |
|      |        | High    | 1990.08         | -23.11               |
|      | 64QAM  | Low     | 1929.93         | -22.36               |
|      |        | High    | 1990.08         | -25.14               |
|      | 256QAM | Low     | 1929.93         | -22.73               |
|      |        | High    | 1990.08         | -21.34               |
| 2    | QPSK   | Low     | 1929.93         | -22.61               |
|      |        | High    | 1990.08         | -23.04               |
|      | 16QAM  | Low     | 1929.93         | -21.28               |
|      |        | High    | 1990.08         | -20.67               |
|      | 64QAM  | Low     | 1929.93         | -23.60               |
|      |        | High    | 1990.08         | -21.20               |
|      | 256QAM | Low     | 1929.93         | -20.85               |
|      |        | High    | 1990.08         | -22.51               |
| 3    | QPSK   | Low     | 1929.93         | -22.61               |
|      |        | High    | 1990.08         | -21.46               |
|      | 16QAM  | Low     | 1929.93         | -21.37               |
|      |        | High    | 1990.08         | -21.13               |
|      | 64QAM  | Low     | 1929.93         | -22.06               |
|      |        | High    | 1990.08         | -23.60               |
|      | 256QAM | Low     | 1929.93         | -21.37               |
|      |        | High    | 1990.08         | -24.20               |

**LTE B2 5 MHz 1 Carrier**

| Ant. | Mod. | Channel | Frequency (MHz) | Measured Value (dBm) |
|------|------|---------|-----------------|----------------------|
| 0    | QPSK | High    | 1990.00         | -20.50               |

**LTE B2 10 MHz 1 Carrier**

| Ant. | Mod.  | Channel | Frequency (MHz) | Measured Value (dBm) |
|------|-------|---------|-----------------|----------------------|
| 1    | 16QAM | High    | 1990.00         | -20.89               |

**LTE B2 15 MHz 1 Carrier**

| Ant. | Mod.   | Channel | Frequency (MHz) | Measured Value (dBm) |
|------|--------|---------|-----------------|----------------------|
| 1    | 256QAM | High    | 1990.00         | -20.86               |

**LTE B2 20 MHz 1 Carrier**

| Ant. | Mod.  | Channel | Frequency (MHz) | Measured Value (dBm) |
|------|-------|---------|-----------------|----------------------|
| 1    | 16QAM | High    | 1990.00         | -20.40               |

Plot Data of Out-of-band Unwanted Emissions

Antenna 0 / B2 DSS 15 MHz 9to1 1 Carrier / 256QAM / Low

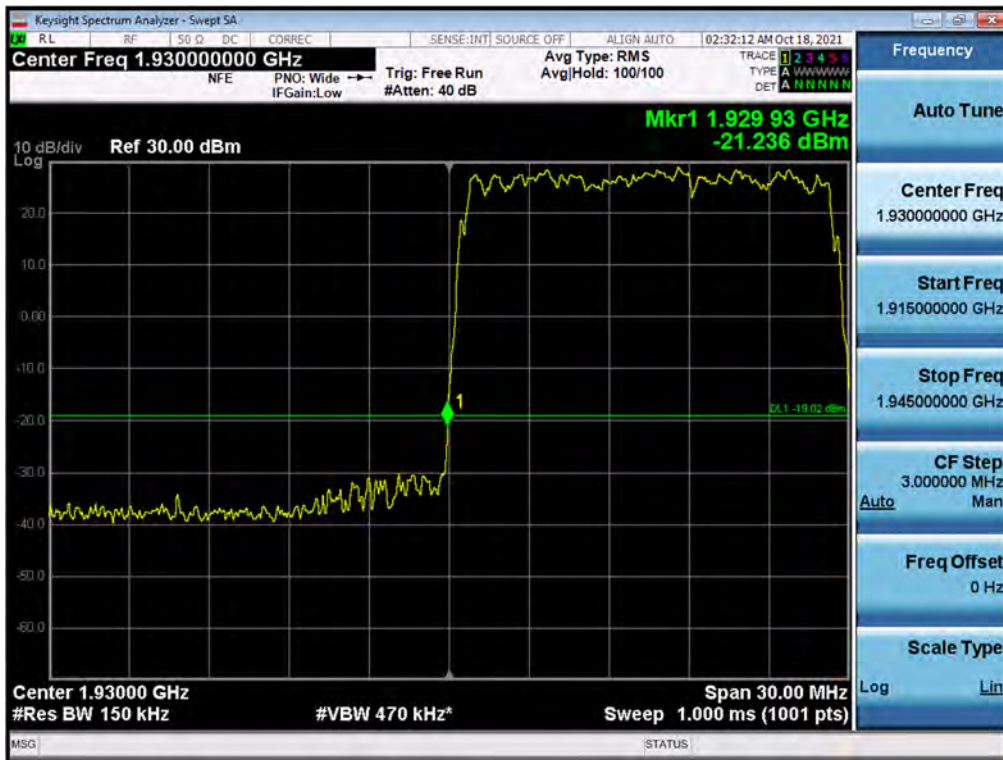

Antenna 2 / B2 DSS 15 MHz 9to1 1 Carrier / 16QAM / High

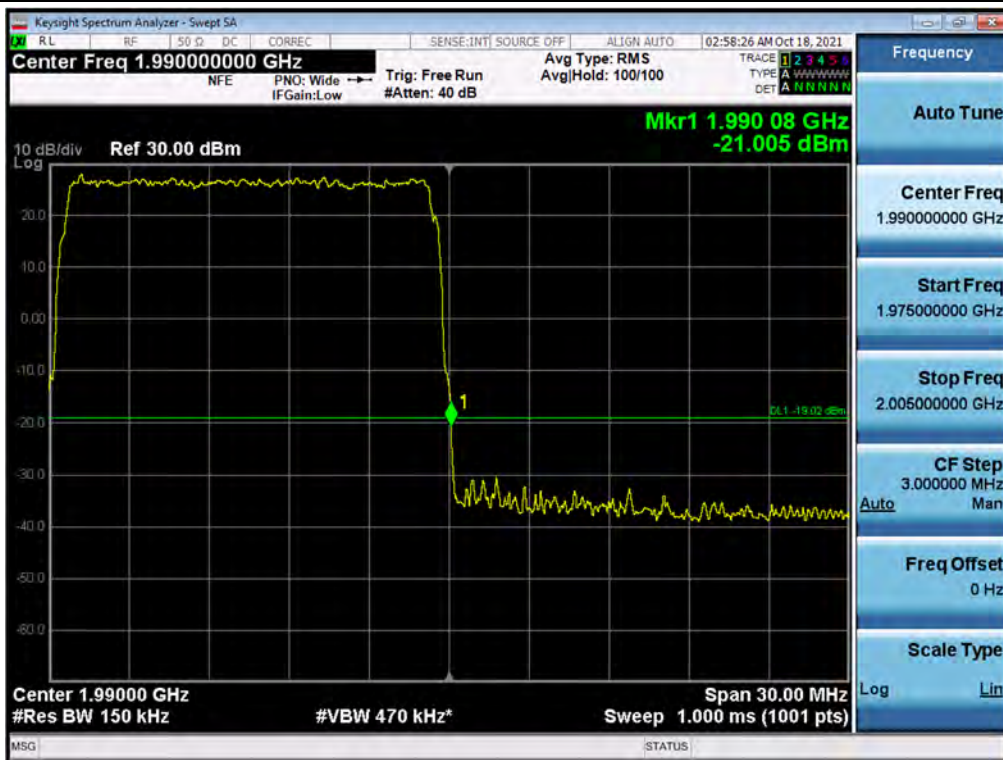

### Antenna 0 / B2 DSS 15 MHz 5to5 1 Carrier / 256QAM / Low

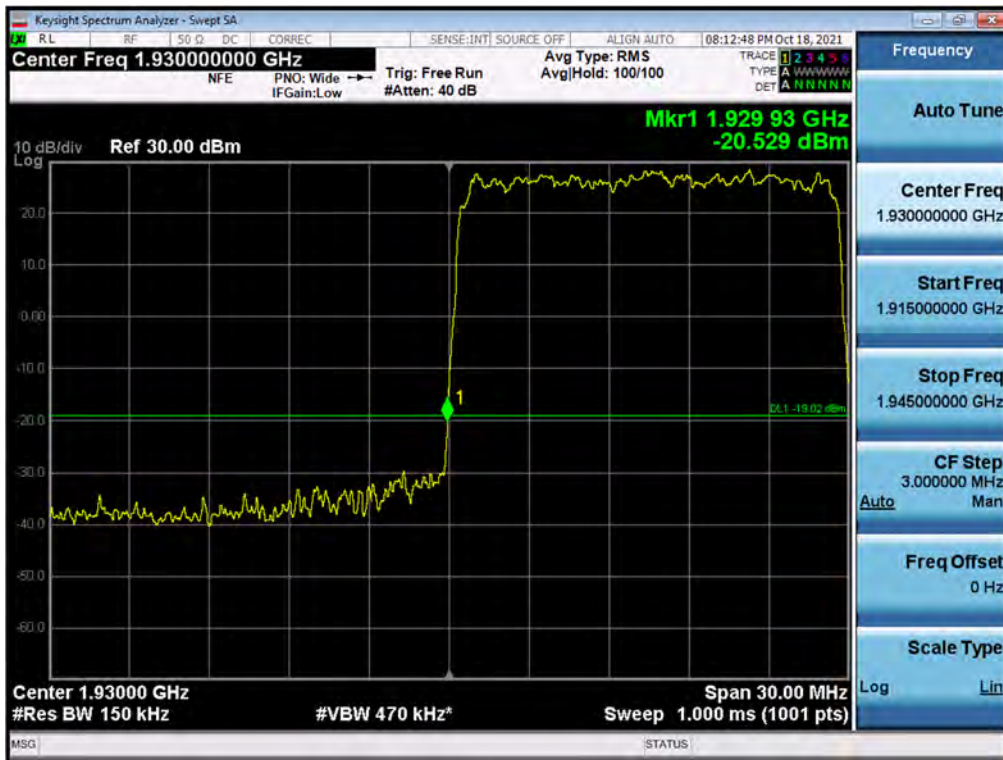

### Antenna 0 / B2 DSS 15 MHz 5to5 1 Carrier / 256QAM / High

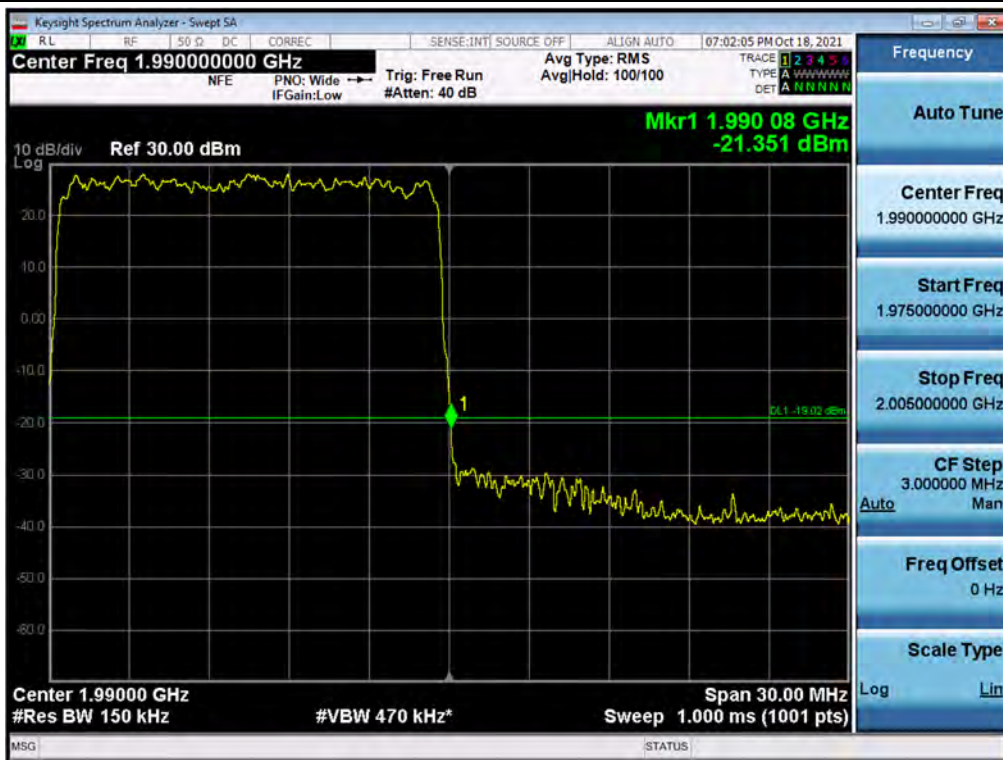

Antenna 2 / B2 DSS 15 MHz 2to8 1 Carrier / 256QAM / Low

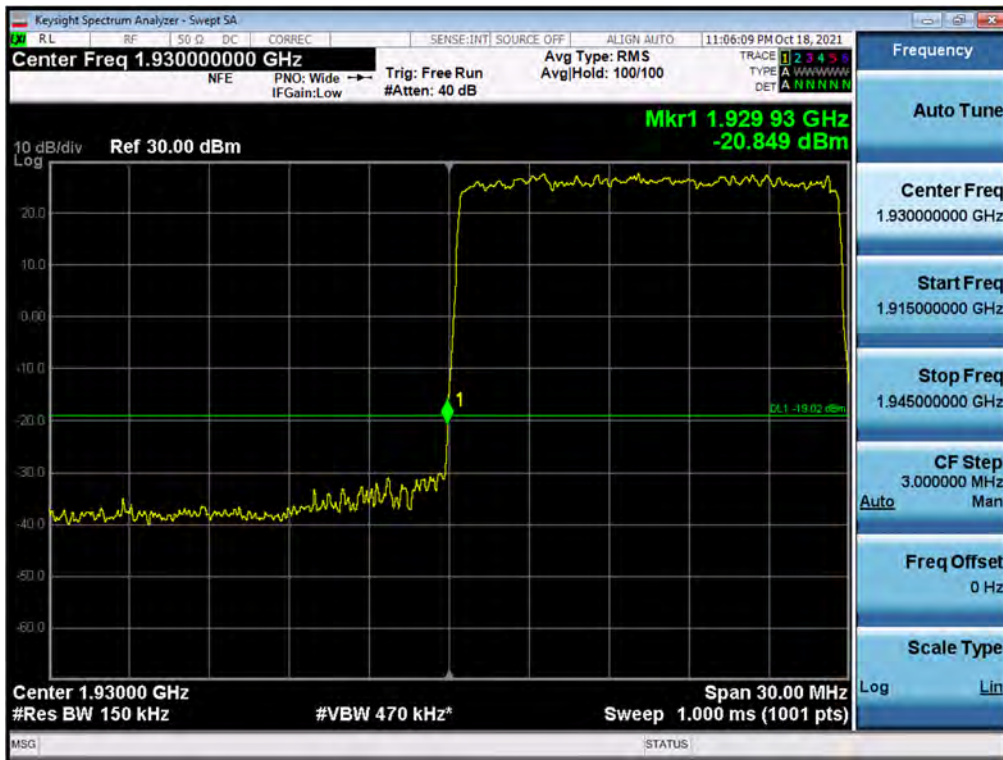

Antenna 2 / B2 DSS 15 MHz 2to8 1 Carrier / 16QAM / High

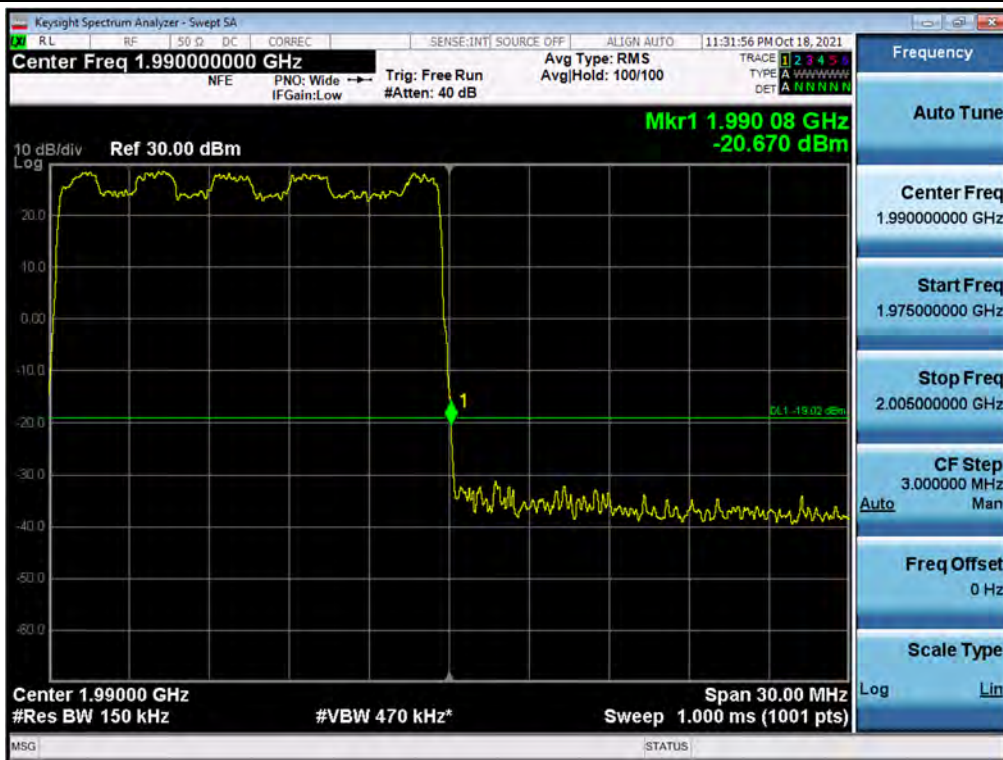

Antenna 1 / LTE B2 20 MHz 1 Carrier / 16QAM / High



## 5.5. SPURIOUS UNWANTED EMISSIONS

### Test Requirements:

#### § 2.1051 Measurements required: Spurious emissions at antenna terminals.

The radio frequency voltage or powers generated within the equipment and appearing on a spurious frequency shall be checked at the equipment output terminals when properly loaded with a suitable artificial antenna. Curves or equivalent data shall show the magnitude of each harmonic and other spurious emission that can be detected when the equipment is operated under the conditions specified in § 2.1049 as appropriate. The magnitude of spurious emissions which are attenuated more than 20 dB below the permissible value need not be specified.

#### § 24.238 Emission limitations for Broadband PCS equipment.

The rules in this section govern the spectral characteristics of emissions in the Broadband Personal Communications Service.

- (a) Out of band emissions. The power of any emission outside of the authorized operating frequency ranges must be attenuated below the transmitting power (P) by a factor of at least  $43 + 10 \log(P)$  dB.
- (b) Measurement procedure. Compliance with these rules is based on the use of measurement instrumentation employing a resolution bandwidth of 1 MHz or greater. However, in the 1 MHz bands immediately outside and adjacent to the frequency block a resolution bandwidth of at least one percent of the emission bandwidth of the fundamental emission of the transmitter may be employed. A narrower resolution bandwidth is permitted in all cases to improve measurement accuracy provided the measured power is integrated over the full required measurement bandwidth (i.e. 1 MHz or 1 percent of emission bandwidth, as specified). The emission bandwidth is defined as the width of the signal between two points, one below the carrier center frequency and one above the carrier center frequency, outside of which all emissions are attenuated at least 26 dB below the transmitter power.
- (c) Alternative out of band emission limit. Licensees in this service may establish an alternative out of band emission limit to be used at specified band edge(s) in specified geographical areas, in lieu of that set forth in this section, pursuant to a private contractual arrangement of all affected licensees and applicants. In this event, each party to such contract shall maintain a copy of the contract in their station files and disclose it to prospective assignees or transferees and, upon request, to the FCC.
- (d) Interference caused by out of band emissions. If any emission from a transmitter operating in this service results in interference to users of another radio service, the FCC may require a greater attenuation of that emission than

### Test Procedures:

The measurement is performed in accordance with Section 5.7.4 of ANSI C63.26.

#### 5.7.4 Spurious unwanted emission measurements

- a) Set the spectrum analyzer start frequency to the lowest frequency generated by the EUT, without going below 9 kHz, and the stop frequency to the lower frequency covered by the measurements previously performed in 5.7.3. As an alternative, the stop frequency can be set to the value specified in 5.1.1, depending on the EUT operating range, if the resulting plot can clearly demonstrate compliance for all frequencies not addressed by the out-of-band emissions measurements performed as per 5.7.3.
- b) When using an average power (rms) detector, ensure that the number of points in the sweep  $\geq 2 \times (\text{span} / \text{RBW})$ . This may

require that the measurement range defined by the start and stop frequencies be subdivided, depending on the spectrum analyzer capabilities. This requirement does not apply to peak-detected power measurements. When average power is specified by the applicable regulation, a peak-detector can be utilized for preliminary measurements to accommodate wider frequency spans. Any emissions found in the preliminary measurement to exceed the applicable limit(s) shall be further examined using a power averaging (rms) detector with the minimum number of measurement points as defined above.

- c) The sweep time should be set to auto-couple for performing peak-detector measurements. For measurements that use a power averaging (rms) detector, the sweep time shall be set as described for out-of-band emissions measurements in item d) of 5.7.3.
- d) Identify and measure the Highest spurious emission levels in each frequency range. It is not necessary to re-measure the out-of-band emissions as a part of this test. Record the frequencies and amplitudes corresponding to the measured emissions and capture the data plots.
- e) Repeat step b) through step d) for the upper spurious emission frequency range if not already captured by a wide span measurement performed as per the alternative provided in step a). The upper frequency for this measurement is defined in 5.1.1 as a function of the EUT operating range.
- f) Compare the results with the corresponding limit in the applicable regulation.
- g) The test report shall include the data plots of the measuring instrument display and the measured data.

**Note:**

1. In 9 kHz to 30 MHz band, RBW narrower than reference bandwidth is used. So following correction factor is applied.  
-  $10 \log [(reference\ bandwidth)/(resolution\ bandwidth)]$   
: 9 kHz to 150 kHz applied 1 kHz RBW,  $10 \log (1\ kHz / 1\ MHz) = - 30\ dB$   
: 150 kHz to 30 MHz applied 10 kHz RBW,  $10 \log (10\ kHz / 1\ MHz) = - 20\ dB$   
: Edge freq. to edge  $\pm 100\ MHz$  applied 100 kHz RBW,  $10 \log (100\ kHz / 1\ MHz) = - 10\ dB$
2. Due to MIMO operations, a correction has been added to the limit according to KDB 662911 D01 v02r01.  
- 4Tx MIMO correction:  $10 \log(N_{ANT}) = 10 \log(4) = 6.02\ dB$  //  $-13\ dBm - 10 * \log(4) = -19.02\ dBm$
3. The results of the Spurious Unwanted Emissions shown above the frequency measured values are very small and similar trend for each port, so we are attached only the worst case plot.



**Test Results:**
**Tabular Data of Spurious Unwanted Emissions**
**B2 DSS 15 MHz 9to1 1 Carrier**
**Test Result for Output Port 0**

| Mod.   | Channel | Measured Level (dBm) |                  |                             |                               |                                 |                              |                   |
|--------|---------|----------------------|------------------|-----------------------------|-------------------------------|---------------------------------|------------------------------|-------------------|
|        |         | 9 kHz ~ 150 kHz      | 150 kHz ~ 30 MHz | 30 MHz ~ Low Edge ~ 100 MHz | Low Edge ~ 100 MHz ~ Low Edge | High Edge ~ High Edge + 100 MHz | High Edge + 100 MHz ~ 10 GHz | 10 GHz ~ 26.5 GHz |
| QPSK   | Low     | -26.199              | -29.985          | -38.909                     | -36.508                       | -28.392                         | -26.636                      | -26.646           |
|        | Middle  | -25.867              | -29.163          | -38.864                     | -27.416                       | -27.647                         | -28.529                      | -26.271           |
|        | High    | -25.734              | -30.511          | -38.239                     | -27.582                       | -35.138                         | -28.210                      | -26.709           |
| 16QAM  | Low     | -26.536              | -29.431          | -38.495                     | -36.654                       | -27.611                         | -28.023                      | -27.235           |
|        | Middle  | -25.301              | -30.588          | -39.064                     | -27.598                       | -27.746                         | -28.669                      | -27.818           |
|        | High    | -25.159              | -30.555          | -37.798                     | -27.135                       | -34.441                         | -28.190                      | -25.115           |
| 64QAM  | Low     | -26.459              | -29.099          | -38.622                     | -35.282                       | -28.099                         | -28.444                      | -27.328           |
|        | Middle  | -24.904              | -29.675          | -38.364                     | -27.473                       | -27.624                         | -28.753                      | -27.213           |
|        | High    | -26.199              | -28.307          | -38.475                     | -27.489                       | -35.238                         | -29.091                      | -26.280           |
| 256QAM | Low     | -25.597              | -30.213          | -38.563                     | -35.062                       | -28.229                         | -28.678                      | -25.272           |
|        | Middle  | -25.979              | -30.439          | -38.291                     | -27.843                       | -27.384                         | -29.404                      | -26.690           |
|        | High    | -25.739              | -30.244          | -38.832                     | -27.857                       | -33.806                         | -27.967                      | -27.020           |

**Test Result for Output Port 1**

| Mod.   | Channel | Measured Level (dBm) |                  |                             |                               |                                 |                              |                   |
|--------|---------|----------------------|------------------|-----------------------------|-------------------------------|---------------------------------|------------------------------|-------------------|
|        |         | 9 kHz ~ 150 kHz      | 150 kHz ~ 30 MHz | 30 MHz ~ Low Edge ~ 100 MHz | Low Edge ~ 100 MHz ~ Low Edge | High Edge ~ High Edge + 100 MHz | High Edge + 100 MHz ~ 10 GHz | 10 GHz ~ 26.5 GHz |
| QPSK   | Low     | -26.484              | -30.020          | -38.636                     | -35.398                       | -28.275                         | -28.429                      | -26.677           |
|        | Middle  | -25.860              | -28.742          | -39.269                     | -28.056                       | -27.639                         | -28.725                      | -26.165           |
|        | High    | -26.432              | -29.757          | -38.979                     | -27.906                       | -34.583                         | -29.007                      | -27.399           |
| 16QAM  | Low     | -26.155              | -29.719          | -39.324                     | -36.356                       | -28.307                         | -29.404                      | -27.489           |
|        | Middle  | -25.705              | -29.858          | -38.353                     | -27.862                       | -27.837                         | -28.808                      | -27.496           |
|        | High    | -25.530              | -28.951          | -37.537                     | -27.833                       | -34.691                         | -29.444                      | -25.733           |
| 64QAM  | Low     | -25.913              | -30.154          | -37.353                     | -36.575                       | -28.182                         | -29.156                      | -26.573           |
|        | Middle  | -25.282              | -29.397          | -38.322                     | -27.800                       | -27.073                         | -29.272                      | -25.171           |
|        | High    | -25.839              | -29.243          | -38.391                     | -27.757                       | -34.602                         | -28.289                      | -27.795           |
| 256QAM | Low     | -25.563              | -30.293          | -38.513                     | -35.746                       | -27.865                         | -29.467                      | -27.186           |
|        | Middle  | -26.694              | -30.318          | -38.110                     | -27.534                       | -28.035                         | -29.142                      | -26.459           |
|        | High    | -26.589              | -30.102          | -37.996                     | -27.302                       | -33.678                         | -29.753                      | -26.391           |

**Test Result for Output Port 2**

| Mod.   | Channel | Measured Level (dBm) |                  |                             |                               |                                 |                              |                   |
|--------|---------|----------------------|------------------|-----------------------------|-------------------------------|---------------------------------|------------------------------|-------------------|
|        |         | 9 kHz ~ 150 kHz      | 150 kHz ~ 30 MHz | 30 MHz ~ Low Edge - 100 MHz | Low Edge - 100 MHz ~ Low Edge | High Edge ~ High Edge + 100 MHz | High Edge + 100 MHz ~ 10 GHz | 10 GHz ~ 26.5 GHz |
| QPSK   | Low     | -25.727              | -30.422          | -38.499                     | -36.194                       | -30.329                         | -28.751                      | -26.316           |
|        | Middle  | -26.625              | -31.673          | -39.007                     | -28.596                       | -29.356                         | -28.843                      | -25.425           |
|        | High    | -26.238              | -29.476          | -38.786                     | -29.049                       | -35.111                         | -28.459                      | -26.042           |
| 16QAM  | Low     | -27.630              | -30.093          | -38.701                     | -35.370                       | -30.733                         | -28.487                      | -26.357           |
|        | Middle  | -27.181              | -30.373          | -38.282                     | -29.669                       | -29.219                         | -29.191                      | -25.795           |
|        | High    | -27.351              | -30.590          | -38.911                     | -28.924                       | -33.652                         | -29.339                      | -24.092           |
| 64QAM  | Low     | -27.080              | -30.331          | -38.548                     | -36.467                       | -30.096                         | -29.105                      | -26.600           |
|        | Middle  | -25.592              | -31.351          | -38.557                     | -29.727                       | -29.777                         | -29.698                      | -25.580           |
|        | High    | -25.648              | -29.516          | -38.158                     | -29.189                       | -34.653                         | -28.456                      | -26.005           |
| 256QAM | Low     | -26.348              | -30.583          | -38.142                     | -36.610                       | -30.448                         | -27.818                      | -25.571           |
|        | Middle  | -25.617              | -30.537          | -38.807                     | -29.487                       | -29.546                         | -29.938                      | -26.261           |
|        | High    | -28.344              | -28.310          | -38.524                     | -29.910                       | -34.518                         | -28.971                      | -25.824           |

**Test Result for Output Port 3**

| Mod.   | Channel | Measured Level (dBm) |                  |                             |                               |                                 |                              |                   |
|--------|---------|----------------------|------------------|-----------------------------|-------------------------------|---------------------------------|------------------------------|-------------------|
|        |         | 9 kHz ~ 150 kHz      | 150 kHz ~ 30 MHz | 30 MHz ~ Low Edge - 100 MHz | Low Edge - 100 MHz ~ Low Edge | High Edge ~ High Edge + 100 MHz | High Edge + 100 MHz ~ 10 GHz | 10 GHz ~ 26.5 GHz |
| QPSK   | Low     | -27.538              | -29.236          | -37.106                     | -35.802                       | -29.739                         | -29.014                      | -24.819           |
|        | Middle  | -25.713              | -29.648          | -37.630                     | -28.674                       | -29.128                         | -29.388                      | -24.756           |
|        | High    | -26.550              | -30.299          | -36.369                     | -29.046                       | -34.510                         | -28.068                      | -23.366           |
| 16QAM  | Low     | -25.043              | -30.746          | -36.563                     | -35.630                       | -29.526                         | -29.044                      | -24.259           |
|        | Middle  | -26.489              | -30.523          | -36.012                     | -28.290                       | -29.183                         | -27.247                      | -25.134           |
|        | High    | -26.708              | -30.739          | -38.036                     | -29.654                       | -34.954                         | -28.671                      | -23.306           |
| 64QAM  | Low     | -26.629              | -30.240          | -37.579                     | -35.246                       | -29.743                         | -29.851                      | -23.751           |
|        | Middle  | -26.456              | -30.183          | -36.737                     | -28.974                       | -29.404                         | -29.723                      | -24.499           |
|        | High    | -26.544              | -29.509          | -36.830                     | -29.342                       | -34.682                         | -27.798                      | -24.807           |
| 256QAM | Low     | -26.390              | -29.638          | -35.720                     | -35.651                       | -29.381                         | -28.888                      | -24.465           |
|        | Middle  | -26.159              | -30.303          | -36.749                     | -29.363                       | -29.335                         | -28.329                      | -25.387           |
|        | High    | -26.475              | -30.203          | -35.791                     | -29.547                       | -34.770                         | -29.076                      | -24.648           |

**B2 DSS 15 MHz 5to5 1 Carrier  
Test Result for Output Port 0**

| Mod.   | Channel | Measured Level (dBm) |                  |                             |                               |                                 |                              |                   |
|--------|---------|----------------------|------------------|-----------------------------|-------------------------------|---------------------------------|------------------------------|-------------------|
|        |         | 9 kHz ~ 150 kHz      | 150 kHz ~ 30 MHz | 30 MHz ~ Low Edge - 100 MHz | Low Edge - 100 MHz ~ Low Edge | High Edge ~ High Edge + 100 MHz | High Edge + 100 MHz ~ 10 GHz | 10 GHz ~ 26.5 GHz |
| QPSK   | Low     | -27.762              | -28.398          | -37.511                     | -36.966                       | -27.978                         | -28.581                      | -27.055           |
|        | Middle  | -25.631              | -30.141          | -39.534                     | -27.742                       | -26.940                         | -28.713                      | -26.679           |
|        | High    | -25.366              | -29.411          | -39.018                     | -27.612                       | -35.345                         | -29.151                      | -27.202           |
| 16QAM  | Low     | -26.624              | -29.583          | -38.128                     | -35.677                       | -27.476                         | -28.122                      | -26.666           |
|        | Middle  | -24.483              | -30.293          | -39.140                     | -27.888                       | -27.617                         | -28.060                      | -27.966           |
|        | High    | -24.551              | -29.885          | -38.728                     | -27.406                       | -34.550                         | -28.303                      | -27.492           |
| 64QAM  | Low     | -27.053              | -29.215          | -39.301                     | -34.990                       | -27.774                         | -29.321                      | -25.841           |
|        | Middle  | -26.013              | -30.309          | -39.062                     | -27.237                       | -27.724                         | -29.228                      | -26.946           |
|        | High    | -23.901              | -29.435          | -39.210                     | -27.285                       | -35.103                         | -29.402                      | -28.196           |
| 256QAM | Low     | -26.081              | -28.256          | -39.150                     | -35.342                       | -28.218                         | -29.265                      | -27.129           |
|        | Middle  | -25.107              | -30.793          | -38.066                     | -27.771                       | -27.371                         | -28.110                      | -26.202           |
|        | High    | -27.233              | -29.272          | -37.838                     | -27.335                       | -34.603                         | -29.127                      | -28.480           |

**Test Result for Output Port 1**

| Mod.   | Channel | Measured Level (dBm) |                  |                             |                               |                                 |                              |                   |
|--------|---------|----------------------|------------------|-----------------------------|-------------------------------|---------------------------------|------------------------------|-------------------|
|        |         | 9 kHz ~ 150 kHz      | 150 kHz ~ 30 MHz | 30 MHz ~ Low Edge - 100 MHz | Low Edge - 100 MHz ~ Low Edge | High Edge ~ High Edge + 100 MHz | High Edge + 100 MHz ~ 10 GHz | 10 GHz ~ 26.5 GHz |
| QPSK   | Low     | -27.267              | -29.165          | -39.206                     | -36.268                       | -28.487                         | -29.826                      | -25.962           |
|        | Middle  | -26.734              | -29.858          | -39.192                     | -28.016                       | -27.767                         | -28.284                      | -25.042           |
|        | High    | -26.815              | -28.644          | -39.548                     | -27.931                       | -35.467                         | -29.618                      | -26.683           |
| 16QAM  | Low     | -27.142              | -29.874          | -38.147                     | -34.952                       | -28.003                         | -28.450                      | -26.687           |
|        | Middle  | -25.191              | -30.004          | -39.001                     | -28.215                       | -27.478                         | -29.524                      | -27.909           |
|        | High    | -25.596              | -29.223          | -37.796                     | -27.634                       | -35.939                         | -29.485                      | -27.572           |
| 64QAM  | Low     | -26.978              | -29.324          | -38.597                     | -35.796                       | -28.097                         | -29.356                      | -24.811           |
|        | Middle  | -27.571              | -29.401          | -38.766                     | -27.960                       | -27.939                         | -28.388                      | -27.041           |
|        | High    | -22.798              | -28.461          | -40.064                     | -27.643                       | -35.212                         | -30.285                      | -27.611           |
| 256QAM | Low     | -27.093              | -30.162          | -39.180                     | -36.240                       | -28.433                         | -28.455                      | -27.020           |
|        | Middle  | -26.721              | -30.043          | -39.723                     | -28.389                       | -28.092                         | -30.307                      | -27.076           |
|        | High    | -26.747              | -29.557          | -39.992                     | -27.949                       | -33.800                         | -29.615                      | -25.269           |

**Test Result for Output Port 2**

| Mod.   | Channel | Measured Level (dBm) |                  |                             |                               |                                 |                              |                   |
|--------|---------|----------------------|------------------|-----------------------------|-------------------------------|---------------------------------|------------------------------|-------------------|
|        |         | 9 kHz ~ 150 kHz      | 150 kHz ~ 30 MHz | 30 MHz ~ Low Edge - 100 MHz | Low Edge - 100 MHz ~ Low Edge | High Edge ~ High Edge + 100 MHz | High Edge + 100 MHz ~ 10 GHz | 10 GHz ~ 26.5 GHz |
| QPSK   | Low     | -27.667              | -30.785          | -38.150                     | -35.917                       | -30.404                         | -29.832                      | -26.001           |
|        | Middle  | -24.979              | -30.978          | -39.223                     | -28.503                       | -29.435                         | -29.658                      | -26.756           |
|        | High    | -25.553              | -31.297          | -39.181                     | -29.628                       | -35.441                         | -30.057                      | -27.054           |
| 16QAM  | Low     | -28.214              | -30.582          | -38.641                     | -35.947                       | -29.488                         | -29.059                      | -26.570           |
|        | Middle  | -24.925              | -30.632          | -39.069                     | -29.391                       | -29.911                         | -30.016                      | -24.916           |
|        | High    | -26.081              | -31.659          | -39.375                     | -29.837                       | -34.776                         | -29.120                      | -25.933           |
| 64QAM  | Low     | -26.696              | -30.318          | -38.347                     | -35.762                       | -30.004                         | -29.111                      | -25.956           |
|        | Middle  | -26.337              | -31.021          | -39.063                     | -29.335                       | -29.297                         | -28.913                      | -26.550           |
|        | High    | -26.453              | -30.478          | -38.362                     | -29.877                       | -35.380                         | -29.604                      | -26.255           |
| 256QAM | Low     | -26.472              | -30.028          | -38.501                     | -34.080                       | -29.968                         | -29.322                      | -26.071           |
|        | Middle  | -26.468              | -31.086          | -38.749                     | -29.267                       | -29.158                         | -29.751                      | -26.899           |
|        | High    | -23.222              | -30.101          | -38.311                     | -29.663                       | -34.851                         | -30.124                      | -25.827           |

**Test Result for Output Port 3**

| Mod.   | Channel | Measured Level (dBm) |                  |                             |                               |                                 |                              |                   |
|--------|---------|----------------------|------------------|-----------------------------|-------------------------------|---------------------------------|------------------------------|-------------------|
|        |         | 9 kHz ~ 150 kHz      | 150 kHz ~ 30 MHz | 30 MHz ~ Low Edge - 100 MHz | Low Edge - 100 MHz ~ Low Edge | High Edge ~ High Edge + 100 MHz | High Edge + 100 MHz ~ 10 GHz | 10 GHz ~ 26.5 GHz |
| QPSK   | Low     | -27.186              | -30.960          | -35.932                     | -36.198                       | -28.941                         | -28.354                      | -23.825           |
|        | Middle  | -26.820              | -31.016          | -36.846                     | -29.028                       | -28.629                         | -28.520                      | -25.635           |
|        | High    | -24.117              | -28.128          | -36.630                     | -29.137                       | -35.383                         | -29.524                      | -25.074           |
| 16QAM  | Low     | -27.814              | -29.661          | -37.160                     | -35.931                       | -28.779                         | -28.004                      | -25.169           |
|        | Middle  | -25.475              | -30.110          | -37.091                     | -28.555                       | -29.265                         | -29.333                      | -24.253           |
|        | High    | -26.034              | -27.500          | -37.994                     | -29.517                       | -35.736                         | -29.786                      | -22.464           |
| 64QAM  | Low     | -26.857              | -29.252          | -35.918                     | -35.361                       | -29.376                         | -28.982                      | -25.105           |
|        | Middle  | -26.127              | -31.111          | -37.230                     | -28.640                       | -28.504                         | -29.675                      | -23.963           |
|        | High    | -26.006              | -29.504          | -37.558                     | -29.404                       | -34.904                         | -29.358                      | -23.495           |
| 256QAM | Low     | -27.003              | -30.304          | -36.273                     | -34.708                       | -29.683                         | -30.112                      | -24.490           |
|        | Middle  | -26.256              | -31.623          | -36.311                     | -28.690                       | -29.251                         | -28.851                      | -24.774           |
|        | High    | -25.661              | -28.742          | -36.604                     | -29.387                       | -34.604                         | -28.564                      | -24.666           |

**B2 DSS 15 MHz 2to8 1 Carrier  
Test Result for Output Port 0**

| Mod.   | Channel | Measured Level (dBm) |                  |                             |                               |                                 |                              |                   |
|--------|---------|----------------------|------------------|-----------------------------|-------------------------------|---------------------------------|------------------------------|-------------------|
|        |         | 9 kHz ~ 150 kHz      | 150 kHz ~ 30 MHz | 30 MHz ~ Low Edge - 100 MHz | Low Edge - 100 MHz ~ Low Edge | High Edge ~ High Edge + 100 MHz | High Edge + 100 MHz ~ 10 GHz | 10 GHz ~ 26.5 GHz |
| QPSK   | Low     | -24.706              | -30.602          | -39.501                     | -34.665                       | -27.906                         | -28.528                      | -26.710           |
|        | Middle  | -25.889              | -31.313          | -38.987                     | -27.788                       | -27.587                         | -29.551                      | -26.910           |
|        | High    | -22.332              | -30.701          | -39.249                     | -27.677                       | -35.071                         | -29.035                      | -26.975           |
| 16QAM  | Low     | -25.814              | -30.458          | -37.889                     | -35.565                       | -27.620                         | -28.792                      | -27.090           |
|        | Middle  | -26.675              | -29.701          | -39.064                     | -27.566                       | -27.211                         | -29.809                      | -27.302           |
|        | High    | -22.518              | -30.192          | -37.673                     | -27.452                       | -34.603                         | -28.038                      | -25.670           |
| 64QAM  | Low     | -26.659              | -30.474          | -38.459                     | -35.049                       | -28.159                         | -28.755                      | -26.714           |
|        | Middle  | -26.789              | -31.170          | -39.633                     | -27.343                       | -27.399                         | -28.080                      | -27.469           |
|        | High    | -22.217              | -30.742          | -39.216                     | -27.200                       | -35.423                         | -29.056                      | -25.650           |
| 256QAM | Low     | -27.188              | -30.056          | -39.204                     | -35.011                       | -27.857                         | -28.096                      | -26.937           |
|        | Middle  | -26.950              | -31.136          | -39.255                     | -27.488                       | -27.524                         | -29.638                      | -27.932           |
|        | High    | -22.280              | -30.954          | -38.415                     | -27.260                       | -35.384                         | -29.320                      | -26.146           |

**Test Result for Output Port 1**

| Mod.   | Channel | Measured Level (dBm) |                  |                             |                               |                                 |                              |                   |
|--------|---------|----------------------|------------------|-----------------------------|-------------------------------|---------------------------------|------------------------------|-------------------|
|        |         | 9 kHz ~ 150 kHz      | 150 kHz ~ 30 MHz | 30 MHz ~ Low Edge - 100 MHz | Low Edge - 100 MHz ~ Low Edge | High Edge ~ High Edge + 100 MHz | High Edge + 100 MHz ~ 10 GHz | 10 GHz ~ 26.5 GHz |
| QPSK   | Low     | -27.034              | -29.326          | -39.520                     | -36.010                       | -28.416                         | -29.285                      | -26.148           |
|        | Middle  | -26.811              | -30.721          | -38.529                     | -28.213                       | -27.544                         | -29.309                      | -27.860           |
|        | High    | -23.274              | -29.973          | -39.390                     | -26.842                       | -34.161                         | -29.159                      | -27.116           |
| 16QAM  | Low     | -27.764              | -30.067          | -39.621                     | -34.855                       | -27.788                         | -29.699                      | -26.967           |
|        | Middle  | -26.800              | -30.600          | -39.515                     | -28.267                       | -27.885                         | -29.141                      | -27.105           |
|        | High    | -22.763              | -30.765          | -39.458                     | -27.795                       | -35.365                         | -29.641                      | -27.578           |
| 64QAM  | Low     | -27.543              | -29.981          | -39.161                     | -36.076                       | -28.020                         | -28.585                      | -25.751           |
|        | Middle  | -26.019              | -30.313          | -39.366                     | -27.556                       | -27.388                         | -29.389                      | -26.575           |
|        | High    | -21.780              | -30.374          | -39.253                     | -27.886                       | -35.847                         | -29.413                      | -26.551           |
| 256QAM | Low     | -26.563              | -30.948          | -38.841                     | -35.471                       | -27.174                         | -29.216                      | -26.087           |
|        | Middle  | -26.304              | -29.477          | -39.121                     | -28.102                       | -27.630                         | -29.782                      | -27.219           |
|        | High    | -23.161              | -29.983          | -38.715                     | -27.864                       | -34.947                         | -29.518                      | -26.722           |

**Test Result for Output Port 2**

| Mod.   | Channel | Measured Level (dBm) |                  |                             |                               |                                 |                              |                   |
|--------|---------|----------------------|------------------|-----------------------------|-------------------------------|---------------------------------|------------------------------|-------------------|
|        |         | 9 kHz ~ 150 kHz      | 150 kHz ~ 30 MHz | 30 MHz ~ Low Edge - 100 MHz | Low Edge - 100 MHz ~ Low Edge | High Edge ~ High Edge + 100 MHz | High Edge + 100 MHz ~ 10 GHz | 10 GHz ~ 26.5 GHz |
| QPSK   | Low     | -27.047              | -31.050          | -39.199                     | -36.129                       | -30.160                         | -29.416                      | -26.534           |
|        | Middle  | -25.952              | -30.704          | -38.732                     | -29.835                       | -29.465                         | -29.761                      | -25.769           |
|        | High    | -22.816              | -30.569          | -38.963                     | -30.306                       | -34.457                         | -29.106                      | -25.020           |
| 16QAM  | Low     | -26.539              | -30.611          | -39.325                     | -34.558                       | -30.102                         | -29.773                      | -25.870           |
|        | Middle  | -25.413              | -31.620          | -39.413                     | -29.513                       | -29.209                         | -29.916                      | -26.548           |
|        | High    | -23.290              | -30.552          | -39.002                     | -29.725                       | -34.558                         | -29.919                      | -26.869           |
| 64QAM  | Low     | -27.122              | -30.958          | -38.719                     | -34.915                       | -29.867                         | -28.301                      | -26.137           |
|        | Middle  | -26.310              | -30.833          | -39.021                     | -29.430                       | -29.047                         | -29.092                      | -27.146           |
|        | High    | -22.334              | -31.483          | -38.538                     | -29.503                       | -35.197                         | -29.474                      | -23.963           |
| 256QAM | Low     | -27.345              | -30.919          | -38.804                     | -35.826                       | -30.304                         | -29.355                      | -24.860           |
|        | Middle  | -25.429              | -31.105          | -38.577                     | -29.472                       | -28.463                         | -28.141                      | -24.451           |
|        | High    | -23.937              | -31.603          | -38.635                     | -28.776                       | -34.978                         | -29.096                      | -24.527           |

**Test Result for Output Port 3**

| Mod.   | Channel | Measured Level (dBm) |                  |                             |                               |                                 |                              |                   |
|--------|---------|----------------------|------------------|-----------------------------|-------------------------------|---------------------------------|------------------------------|-------------------|
|        |         | 9 kHz ~ 150 kHz      | 150 kHz ~ 30 MHz | 30 MHz ~ Low Edge - 100 MHz | Low Edge - 100 MHz ~ Low Edge | High Edge ~ High Edge + 100 MHz | High Edge + 100 MHz ~ 10 GHz | 10 GHz ~ 26.5 GHz |
| QPSK   | Low     | -25.390              | -30.225          | -36.794                     | -35.040                       | -28.689                         | -27.752                      | -25.282           |
|        | Middle  | -27.518              | -31.009          | -37.353                     | -28.783                       | -28.850                         | -29.739                      | -25.210           |
|        | High    | -21.991              | -30.955          | -36.884                     | -29.382                       | -33.218                         | -29.316                      | -25.157           |
| 16QAM  | Low     | -26.221              | -30.954          | -37.660                     | -35.073                       | -29.101                         | -28.966                      | -25.766           |
|        | Middle  | -27.220              | -31.539          | -36.807                     | -28.411                       | -28.474                         | -29.520                      | -24.307           |
|        | High    | -22.991              | -30.451          | -37.479                     | -29.762                       | -35.544                         | -28.750                      | -25.334           |
| 64QAM  | Low     | -27.130              | -31.012          | -37.016                     | -35.441                       | -29.232                         | -28.264                      | -25.434           |
|        | Middle  | -26.179              | -29.101          | -36.175                     | -28.398                       | -28.889                         | -29.352                      | -24.855           |
|        | High    | -23.829              | -29.847          | -36.734                     | -29.375                       | -35.051                         | -29.642                      | -23.201           |
| 256QAM | Low     | -26.469              | -30.832          | -36.424                     | -34.975                       | -29.818                         | -28.991                      | -24.433           |
|        | Middle  | -25.987              | -30.164          | -35.957                     | -28.555                       | -28.987                         | -28.340                      | -24.528           |
|        | High    | -23.274              | -29.996          | -36.402                     | -29.604                       | -34.294                         | -28.582                      | -24.071           |

**LTE B2 5 MHz 1 Carrier**  
**Test Result for Output Port 0**

| Mod. | Channel | Measured Level (dBm) |                     |                                   |                                     |                                       |                                    |                      |
|------|---------|----------------------|---------------------|-----------------------------------|-------------------------------------|---------------------------------------|------------------------------------|----------------------|
|      |         | 9 kHz ~<br>150 kHz   | 150 kHz ~<br>30 MHz | 30 MHz ~<br>Low Edge -<br>100 MHz | Low Edge -<br>100 MHz ~<br>Low Edge | High Edge ~<br>High Edge<br>+ 100 MHz | High Edge +<br>100 MHz ~<br>10 GHz | 10 GHz ~<br>26.5 GHz |
| QPSK | High    | -21.485              | -25.744             | -30.630                           | -22.945                             | -22.525                               | -25.267                            | -24.129              |

**LTE B2 10 MHz 1 Carrier**  
**Test Result for Output Port 1**

| Mod.  | Channel | Measured Level (dBm) |                     |                                   |                                     |                                       |                                    |                      |
|-------|---------|----------------------|---------------------|-----------------------------------|-------------------------------------|---------------------------------------|------------------------------------|----------------------|
|       |         | 9 kHz ~<br>150 kHz   | 150 kHz ~<br>30 MHz | 30 MHz ~<br>Low Edge -<br>100 MHz | Low Edge -<br>100 MHz ~<br>Low Edge | High Edge ~<br>High Edge<br>+ 100 MHz | High Edge +<br>100 MHz ~<br>10 GHz | 10 GHz ~<br>26.5 GHz |
| 16QAM | High    | -24.538              | -29.566             | -30.657                           | -23.176                             | -24.312                               | -25.035                            | -24.793              |

**LTE B2 15 MHz 1 Carrier**  
**Test Result for Output Port 1**

| Mod.   | Channel | Measured Level (dBm) |                     |                                   |                                     |                                       |                                    |                      |
|--------|---------|----------------------|---------------------|-----------------------------------|-------------------------------------|---------------------------------------|------------------------------------|----------------------|
|        |         | 9 kHz ~<br>150 kHz   | 150 kHz ~<br>30 MHz | 30 MHz ~<br>Low Edge -<br>100 MHz | Low Edge -<br>100 MHz ~<br>Low Edge | High Edge ~<br>High Edge<br>+ 100 MHz | High Edge +<br>100 MHz ~<br>10 GHz | 10 GHz ~<br>26.5 GHz |
| 256QAM | High    | -21.703              | -25.764             | -30.651                           | -23.277                             | -24.216                               | -24.842                            | -24.941              |

**LTE B2 20 MHz 1 Carrier**  
**Test Result for Output Port 1**

| Mod.  | Channel | Measured Level (dBm) |                     |                                   |                                     |                                       |                                    |                      |
|-------|---------|----------------------|---------------------|-----------------------------------|-------------------------------------|---------------------------------------|------------------------------------|----------------------|
|       |         | 9 kHz ~<br>150 kHz   | 150 kHz ~<br>30 MHz | 30 MHz ~<br>Low Edge -<br>100 MHz | Low Edge -<br>100 MHz ~<br>Low Edge | High Edge ~<br>High Edge<br>+ 100 MHz | High Edge +<br>100 MHz ~<br>10 GHz | 10 GHz ~<br>26.5 GHz |
| 16QAM | High    | -21.241              | -26.682             | -30.818                           | -23.287                             | -24.339                               | -24.847                            | -24.826              |

Plot Data of Spurious Unwanted Emissions

Antenna 0 / 9 kHz ~ 150 kHz / B2 DSS 15 MHz 9to1 1 Carrier / 64QAM / Middle



Antenna 0 / 150 kHz ~ 30 MHz / B2 DSS 15 MHz 9to1 1 Carrier / 64QAM / High

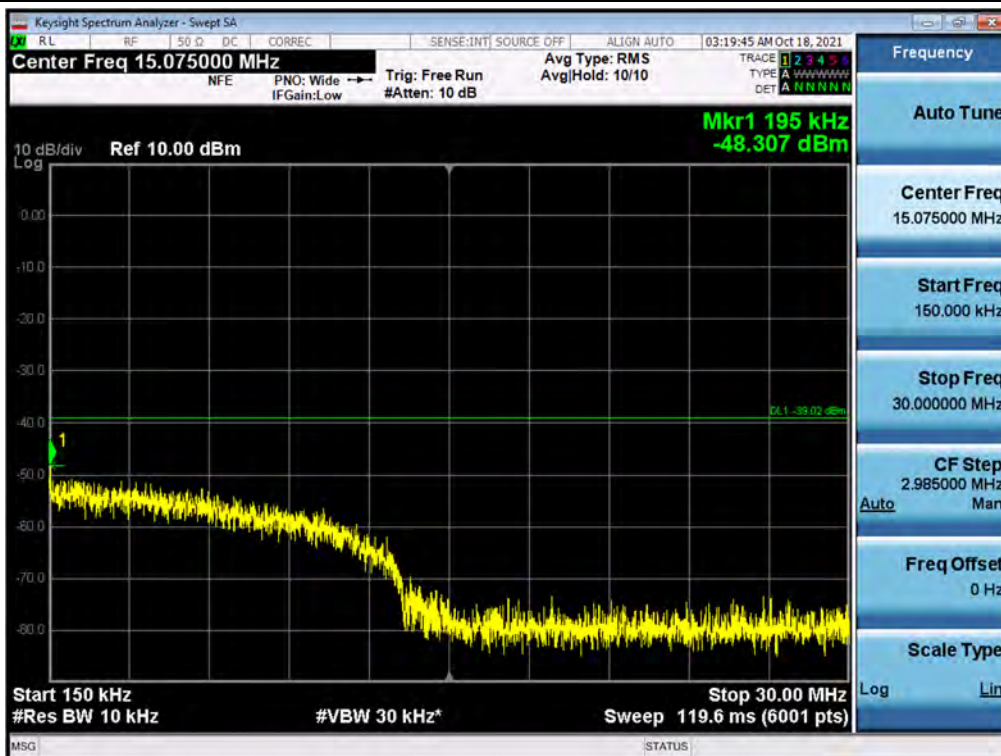



## Antenna 3 / 30 MHz ~ Low Edge - 100 MHz / B2 DSS 15 MHz 9to1 1 Carrier / 256QAM / Low

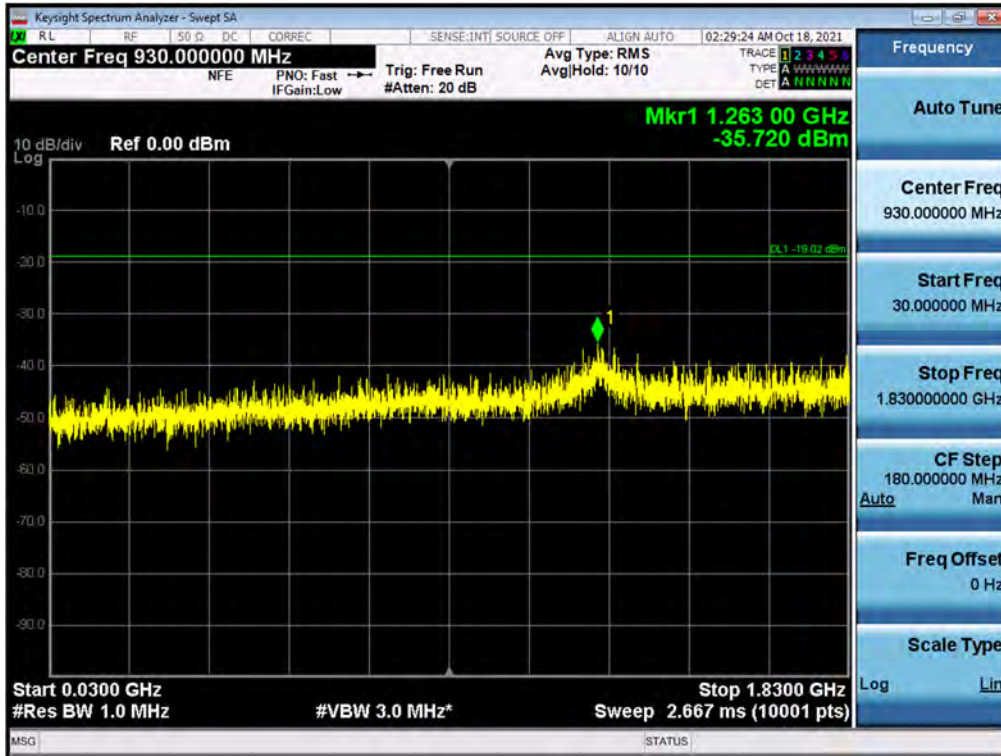

## Antenna 0 / Low Edge - 100 MHz ~ Low Edge / B2 DSS 15 MHz 9to1 1 Carrier / 16QAM / High

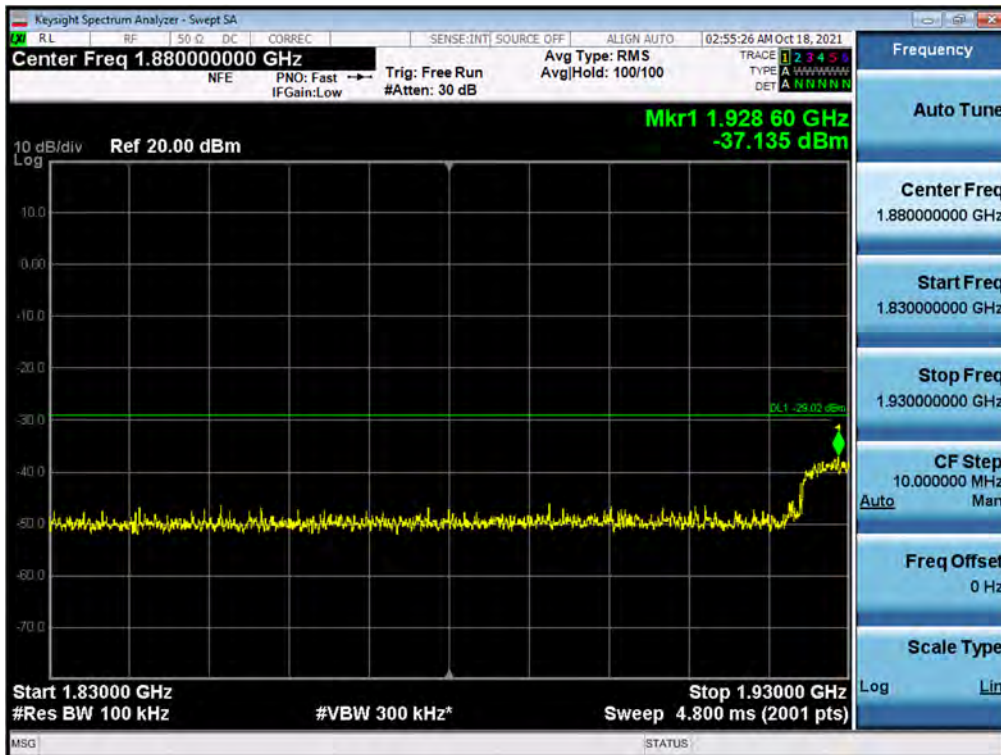

Antenna 1 / High Edge ~ High Edge + 100 MHz / B2 DSS 15 MHz 9to1 1 Carrier / 64QAM / Middle

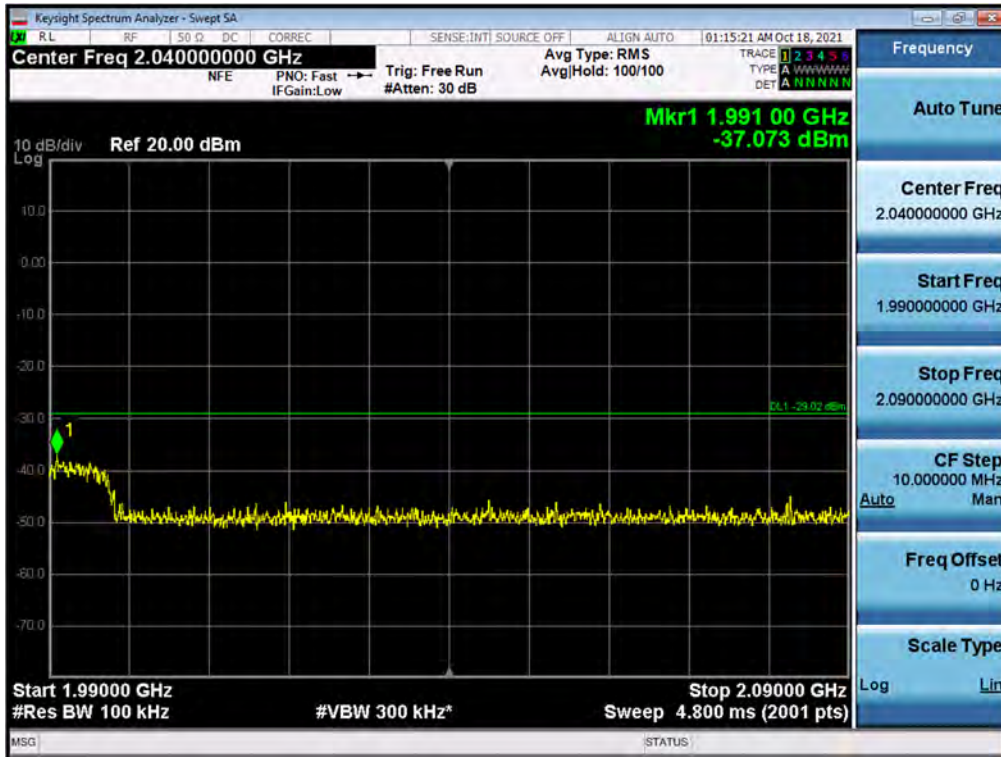

Antenna 0 / High Edge + 100 MHz ~ 10 GHz / B2 DSS 15 MHz 9to1 1 Carrier / QPSK / Low

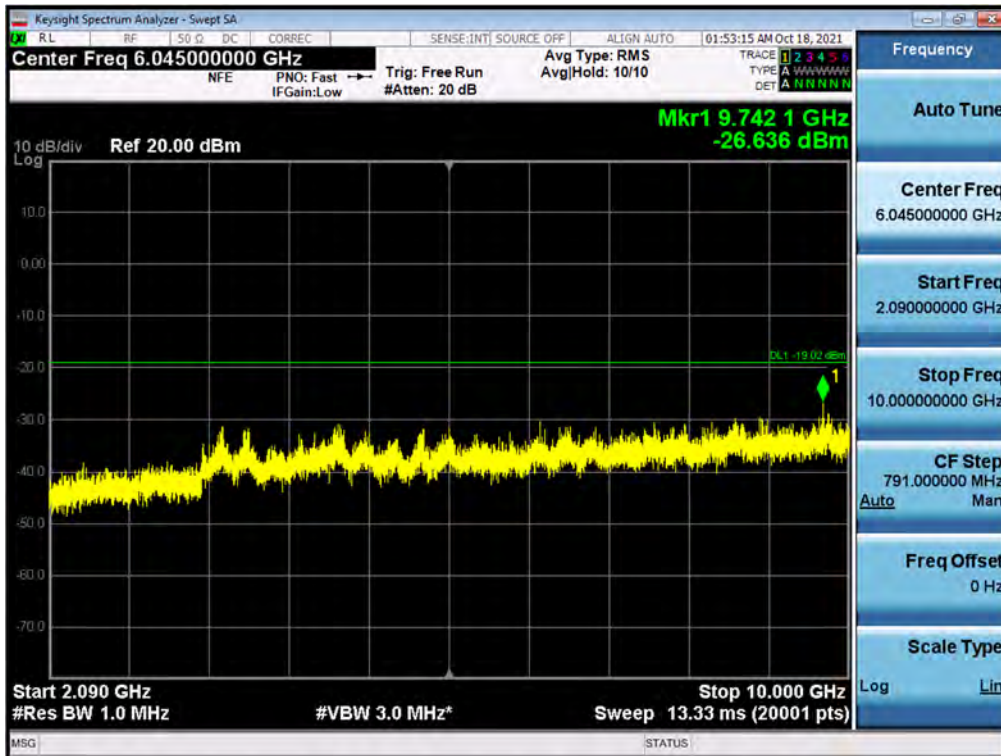

Antenna 3 / 10 GHz ~ 26.5 GHz / B2 DSS 15 MHz 9to1 1 Carrier / 16QAM / High

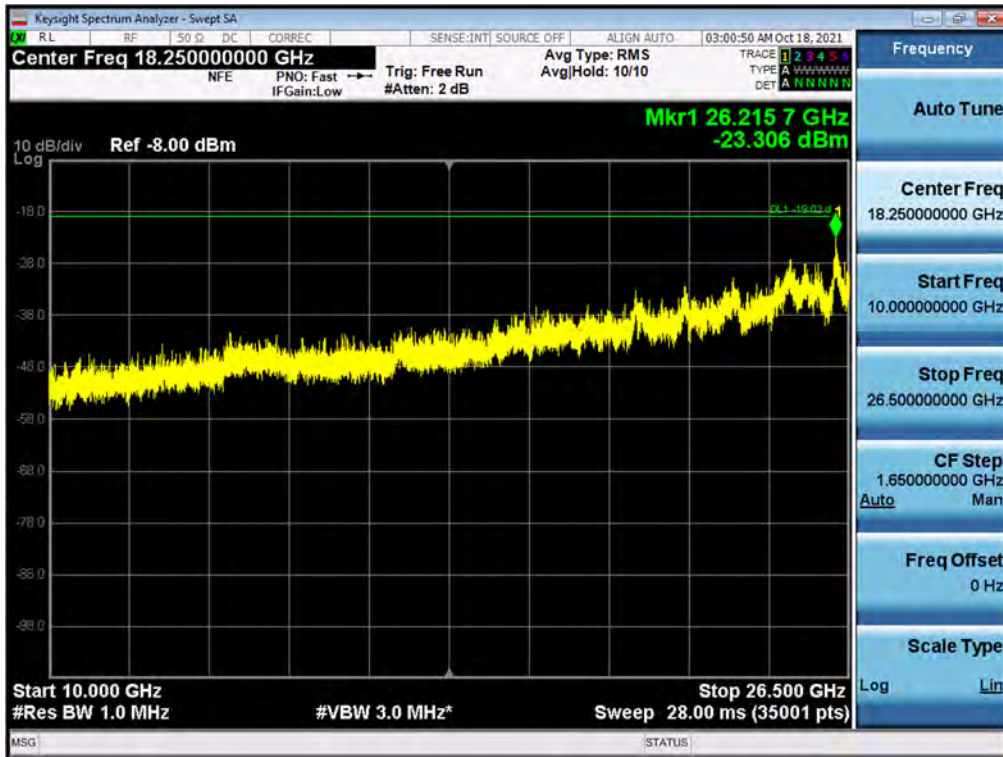

Antenna 1 / 9 kHz ~ 150 kHz / B2 DSS 15 MHz 5to5 1 Carrier / 64QAM / High



Antenna 3 / 150 kHz ~ 30 MHz / B2 DSS 15 MHz 5to5 1 Carrier / 16QAM / High

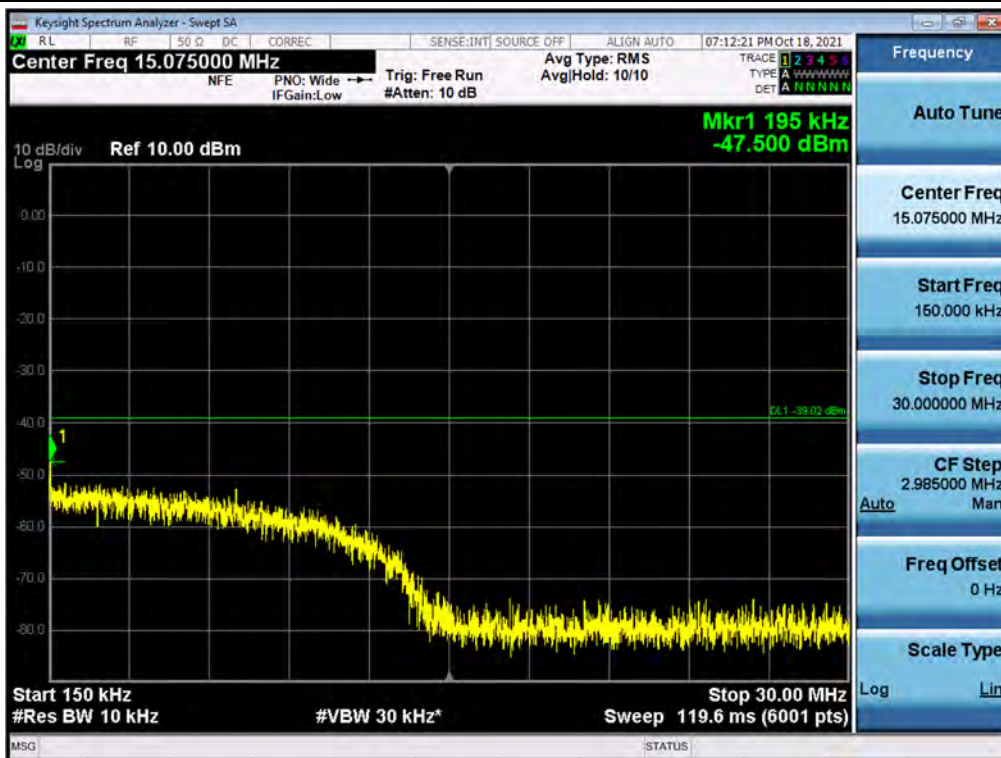

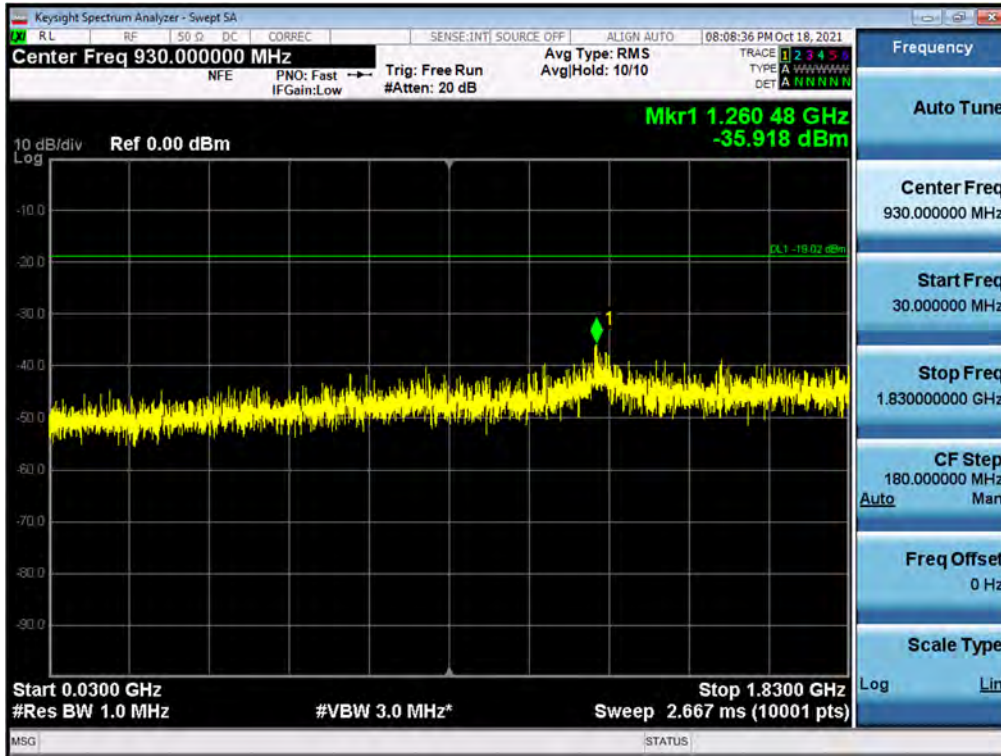
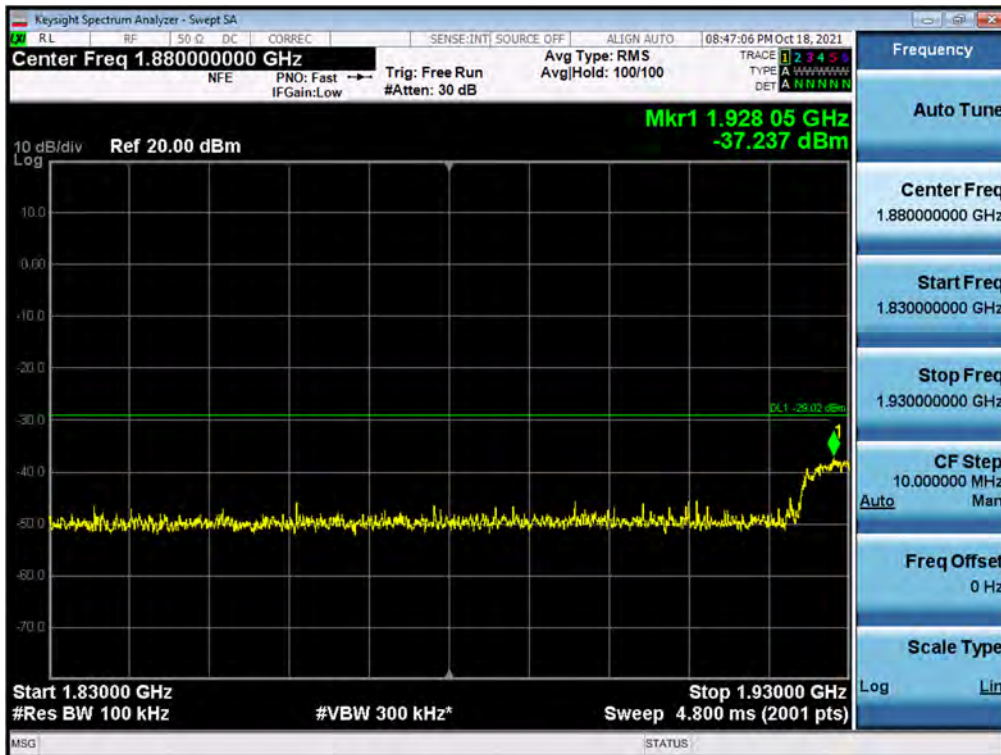
**Antenna 3 / 30 MHz ~ Low Edge - 100 MHz / B2 DSS 15 MHz 5to5 1 Carrier / 64QAM / Low**

**Antenna 0 / Low Edge - 100 MHz ~ Low Edge / B2 DSS 15 MHz 5to5 1 Carrier / 64QAM / Middle**

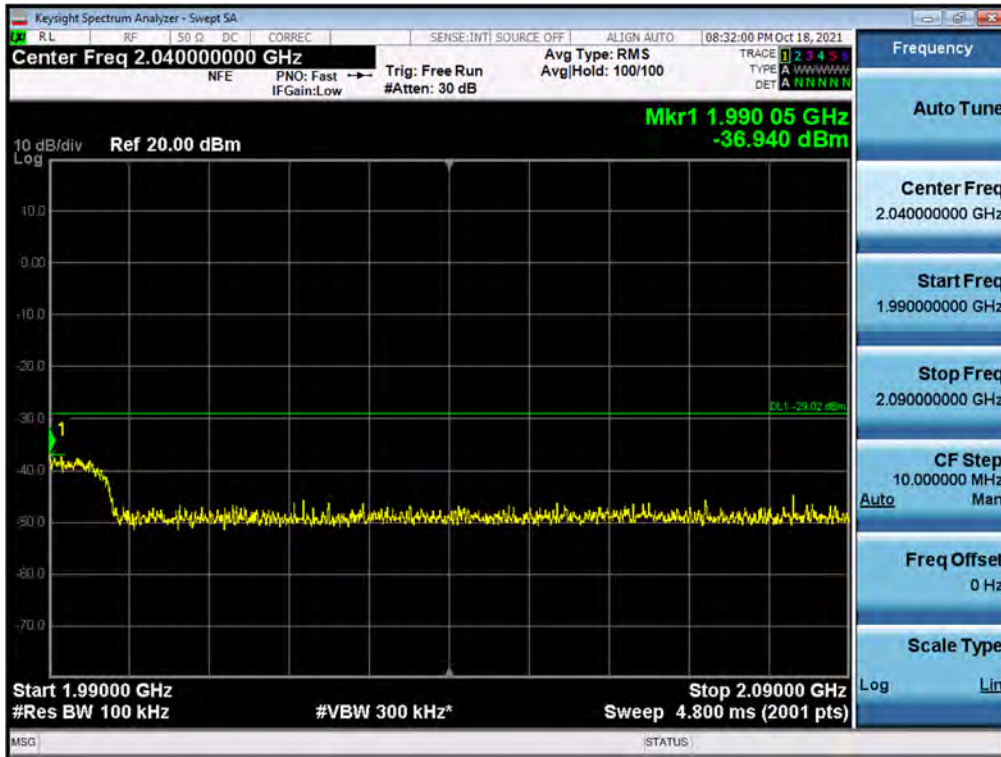
Antenna 0 / High Edge ~ High Edge + 100 MHz / B2 DSS 15 MHz 5to5 1 Carrier / QPSK / Middle

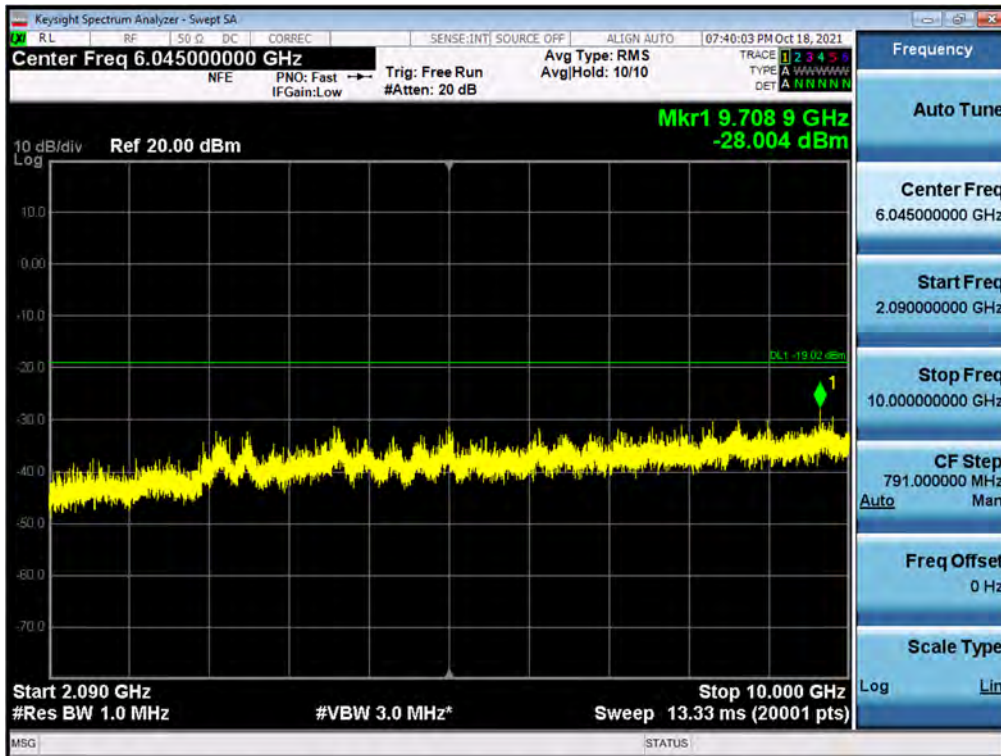

Antenna 3 / High Edge + 100 MHz ~ 10 GHz / B2 DSS 15 MHz 5to5 1 Carrier / 16QAM / Low



Antenna 3 / 10 GHz ~ 26.5 GHz / B2 DSS 15 MHz 5to5 1 Carrier / 16QAM / High

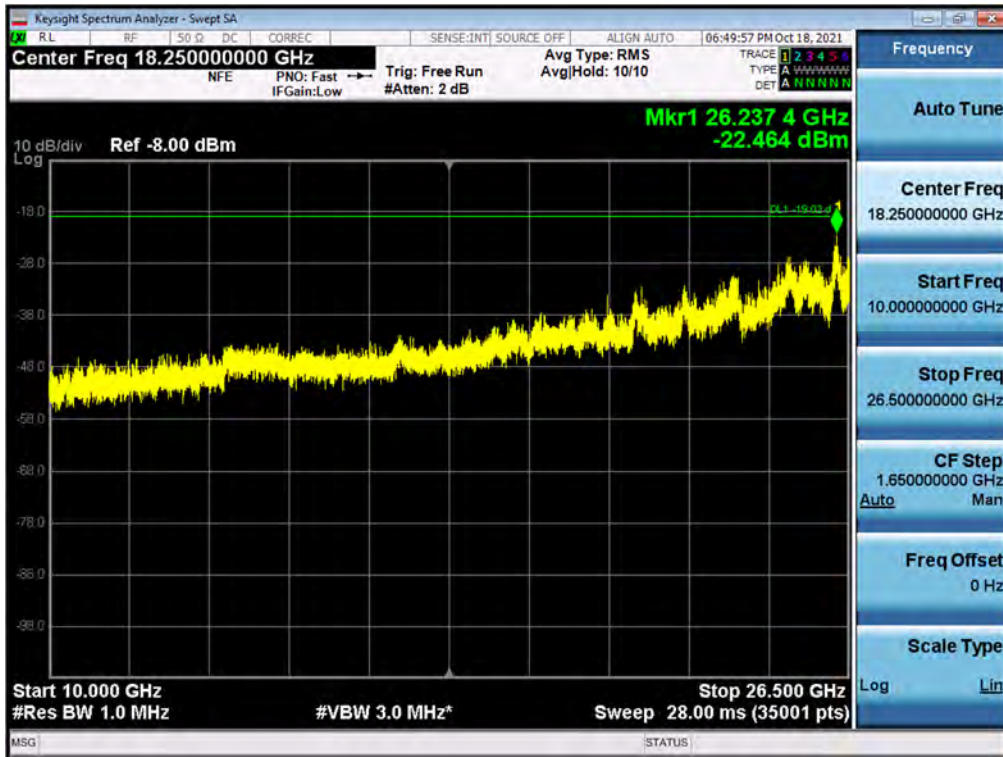

Antenna 1 / 9 kHz ~ 150 kHz / B2 DSS 15 MHz 2to8 1 Carrier / 64QAM / High

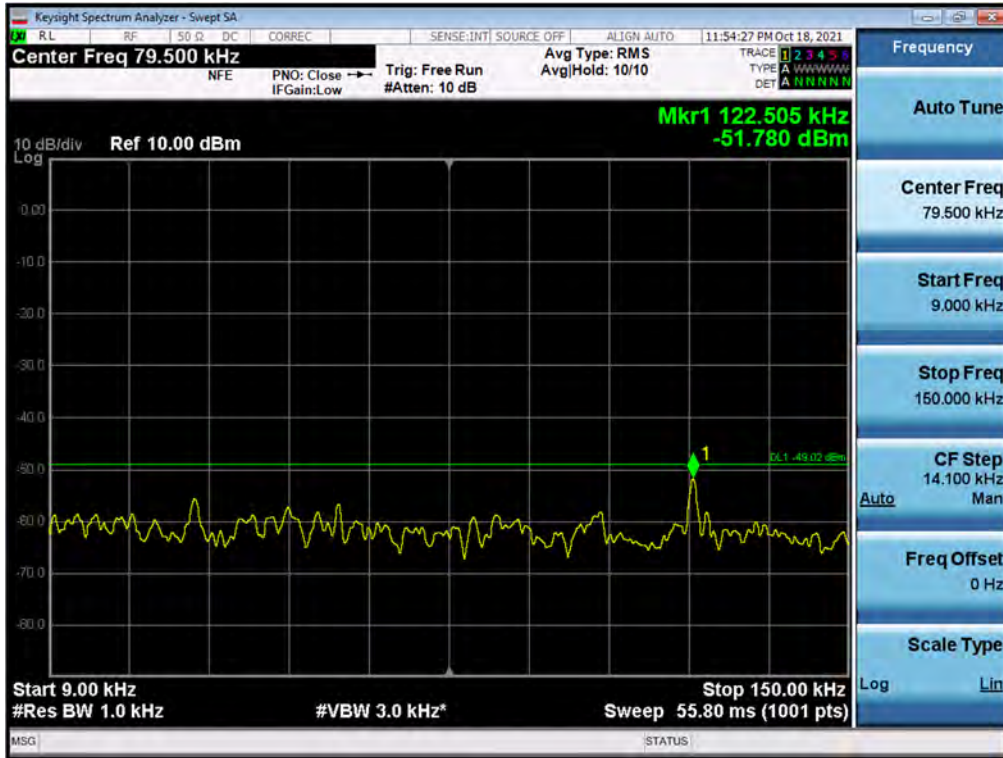

Antenna 3 / 150 kHz ~ 30 MHz / B2 DSS 15 MHz 2to8 1 Carrier / 64QAM / Middle

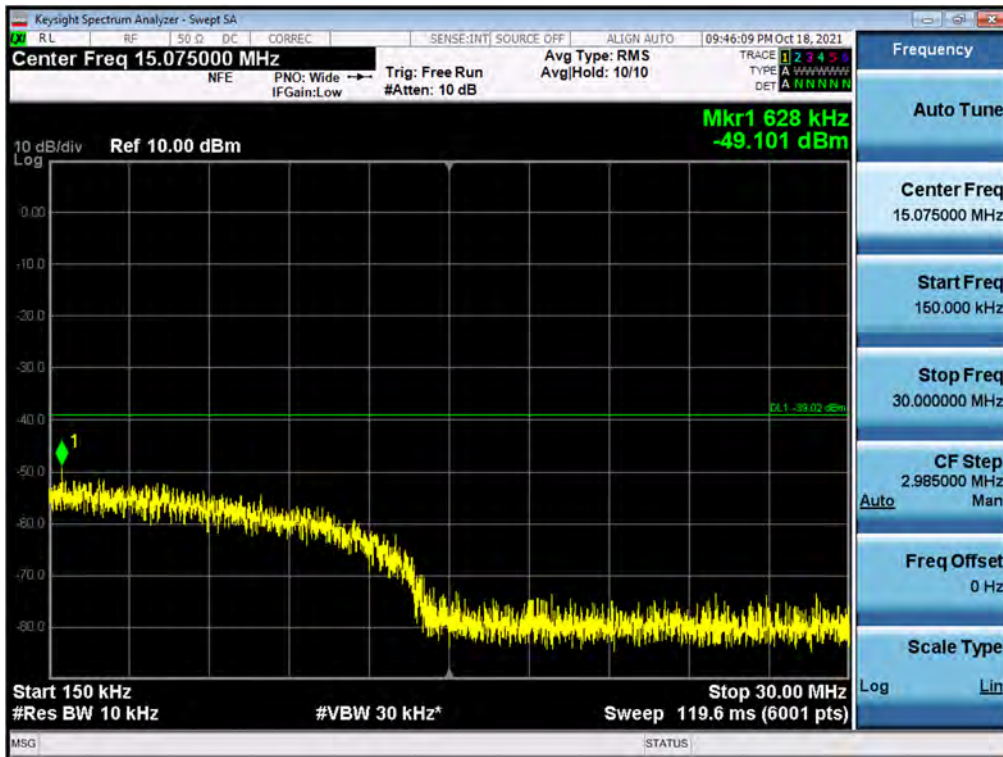



## Antenna 3 / 30 MHz ~ Low Edge - 100 MHz / B2 DSS 15 MHz 2to8 1 Carrier / 256QAM / Middle

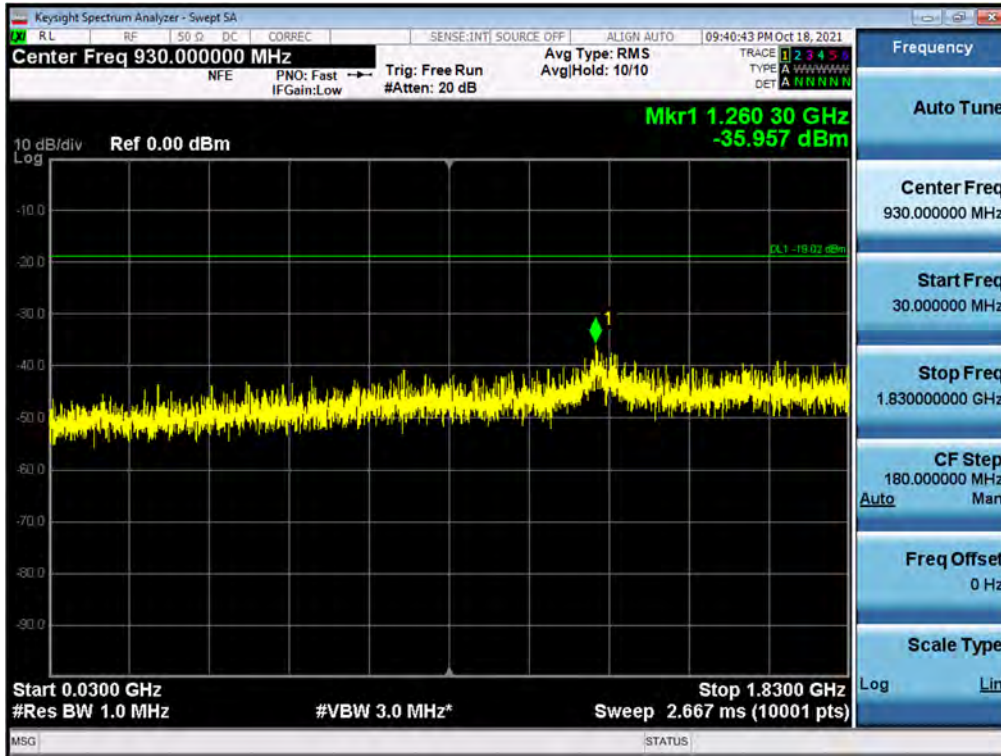

## Antenna 1 / Low Edge - 100 MHz ~ Low Edge / B2 DSS 15 MHz 2to8 1 Carrier / QPSK / High

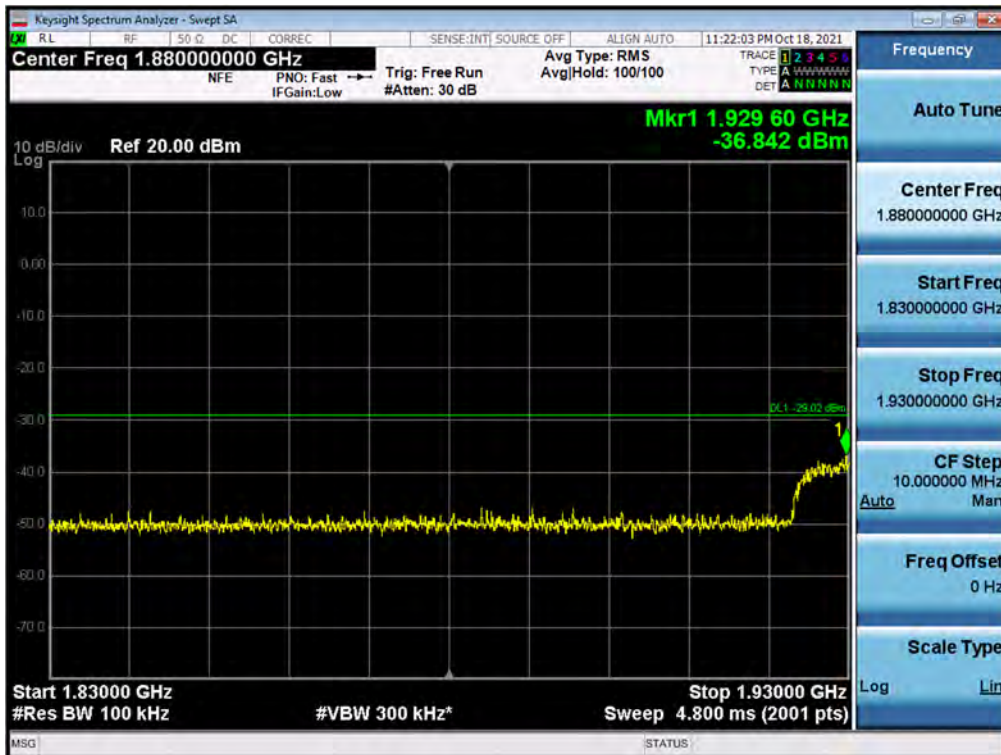

Antenna 1 / High Edge ~ High Edge + 100 MHz / B2 DSS 15 MHz 2to8 1 Carrier / 256QAM / Low

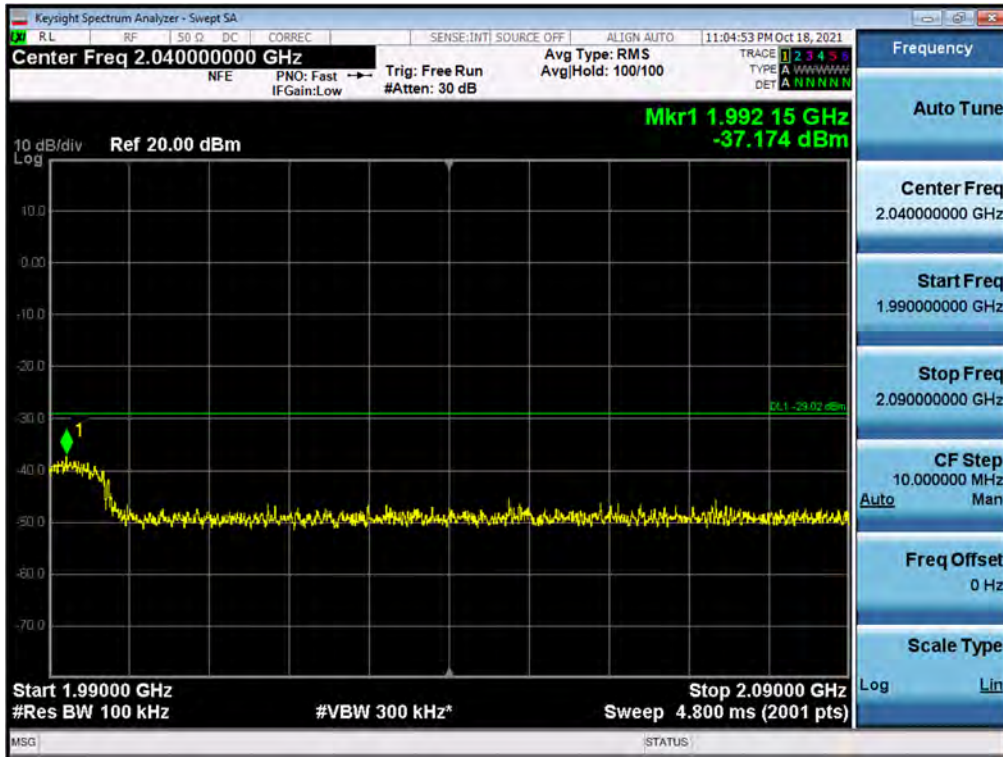

Antenna 3 / High Edge + 100 MHz ~ 10 GHz / B2 DSS 15 MHz 2to8 1 Carrier / QPSK / Low

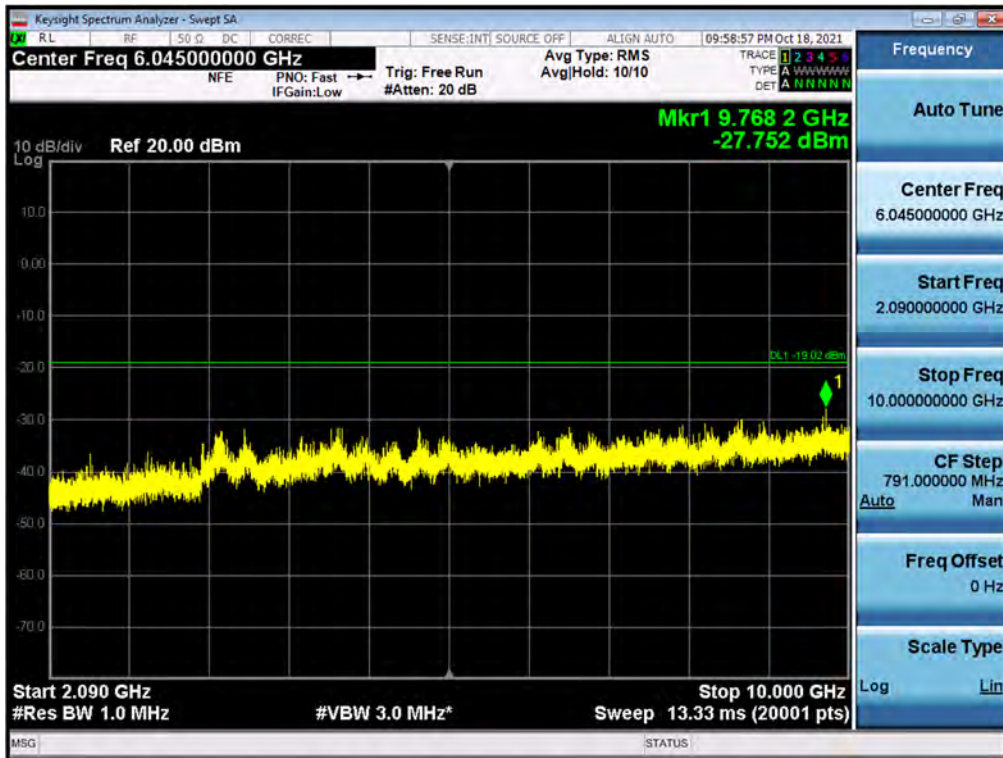

Antenna 3 / 10 GHz ~ 26.5 GHz / B2 DSS 15 MHz 2to8 1 Carrier / 64QAM / High

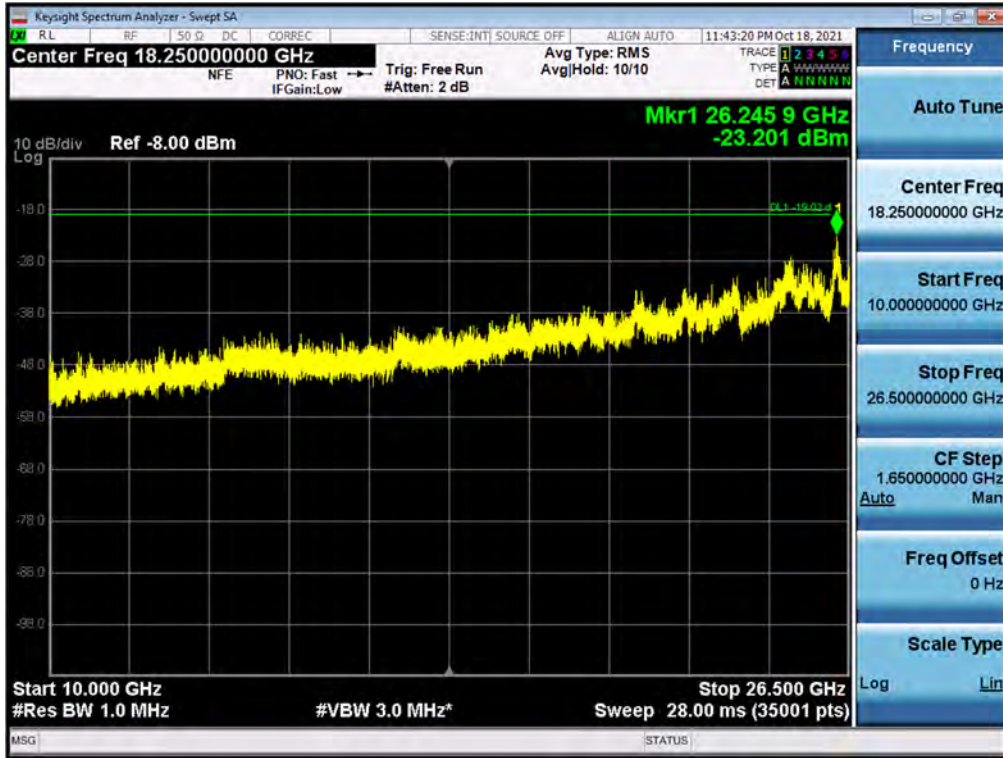

## Antenna 1 / 9 kHz ~ 150 kHz / LTE B2 20 MHz 1 Carrier / 16QAM / High



## Antenna 1 / 150 kHz ~ 30 MHz / LTE B2 20 MHz 1 Carrier / 16QAM / High

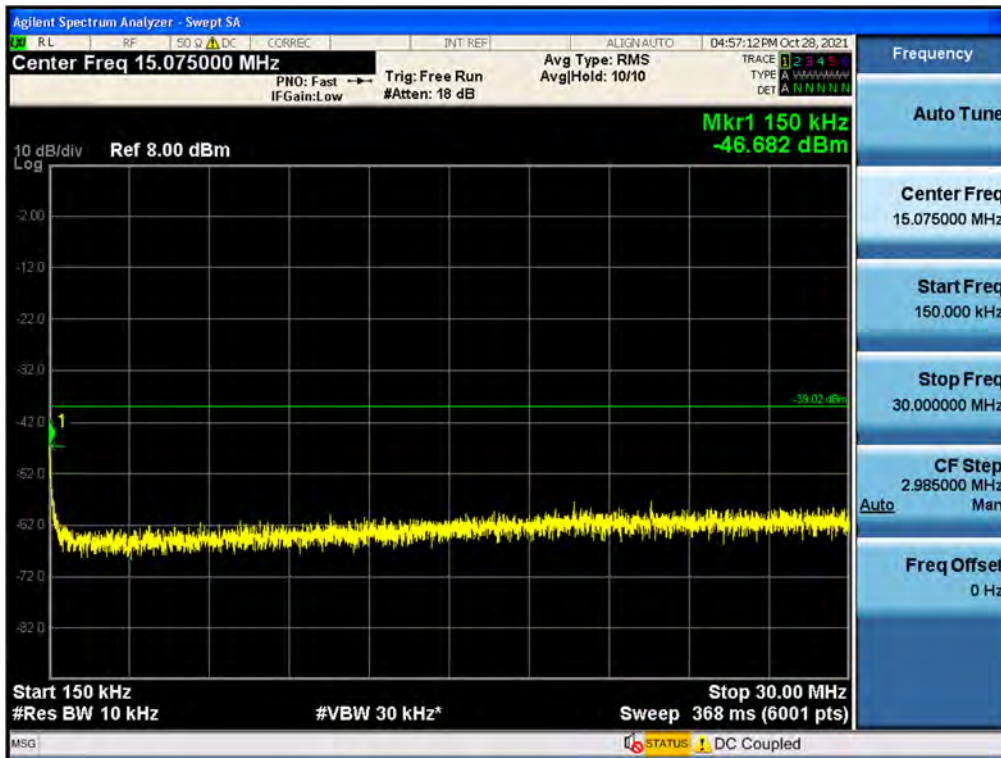

Antenna 1 / 30 MHz ~ Low Edge - 100 MHz / LTE B2 20 MHz 1 Carrier / 16QAM / High

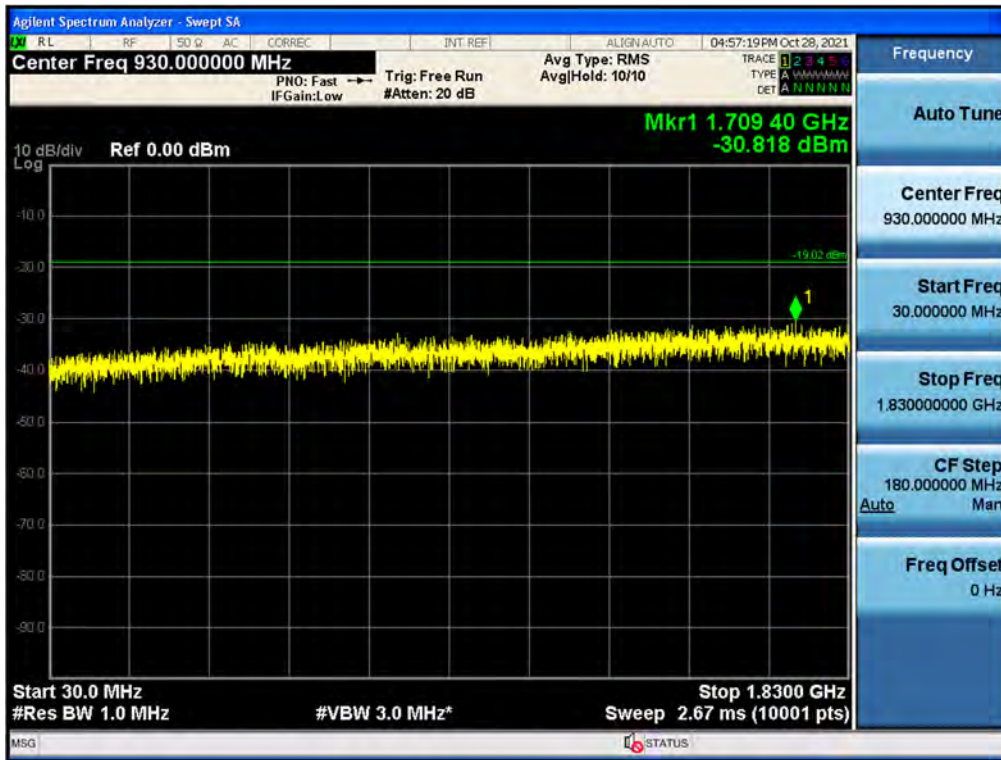

Antenna 1 / Low Edge - 100 MHz ~ Low Edge / LTE B2 20 MHz 1 Carrier / 16QAM / High

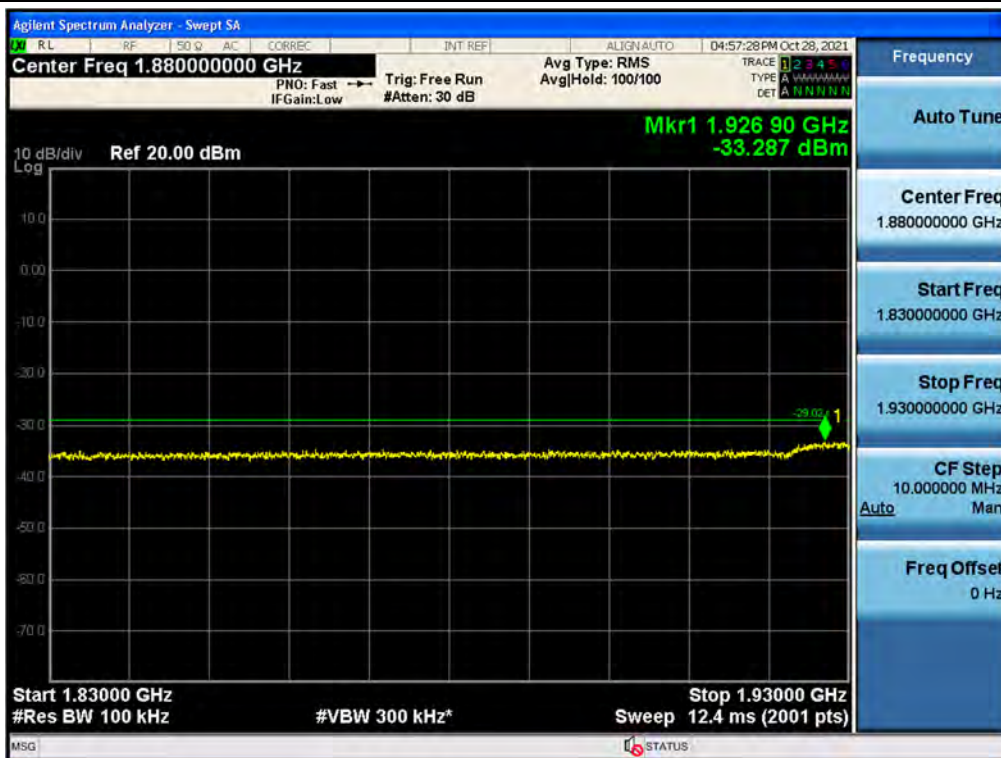

Antenna 1 / High Edge ~ High Edge + 100 MHz / LTE B2 20 MHz 1 Carrier / 16QAM / High

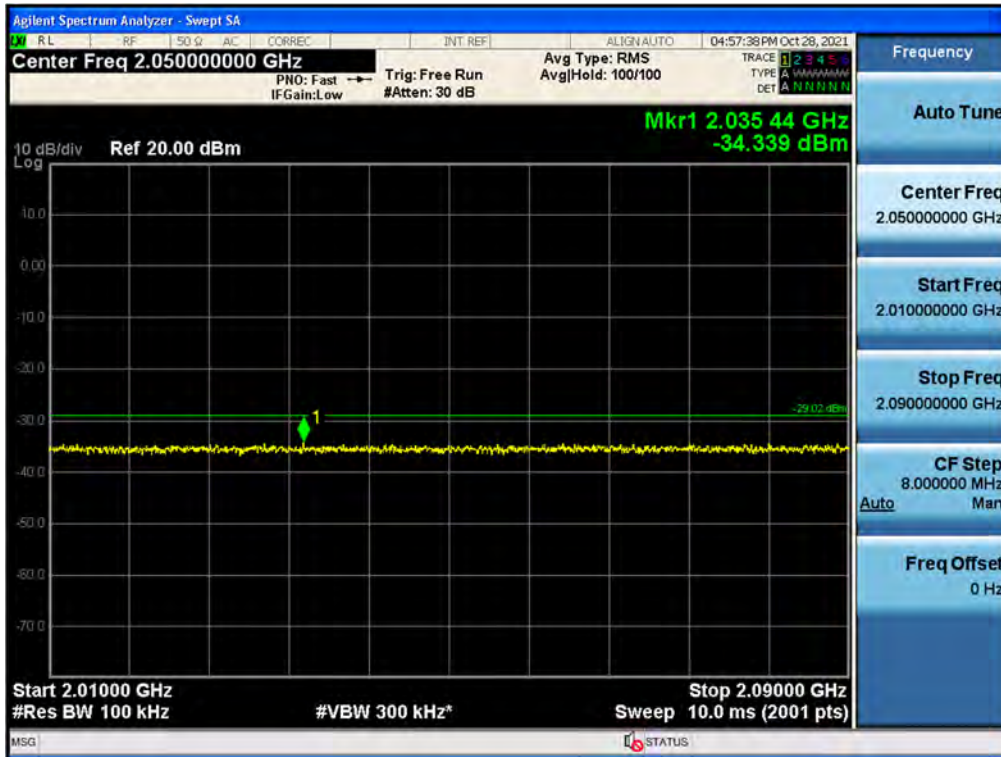

Antenna 1 / High Edge + 100 MHz ~ 10 GHz / LTE B2 20 MHz 1 Carrier / 16QAM / High

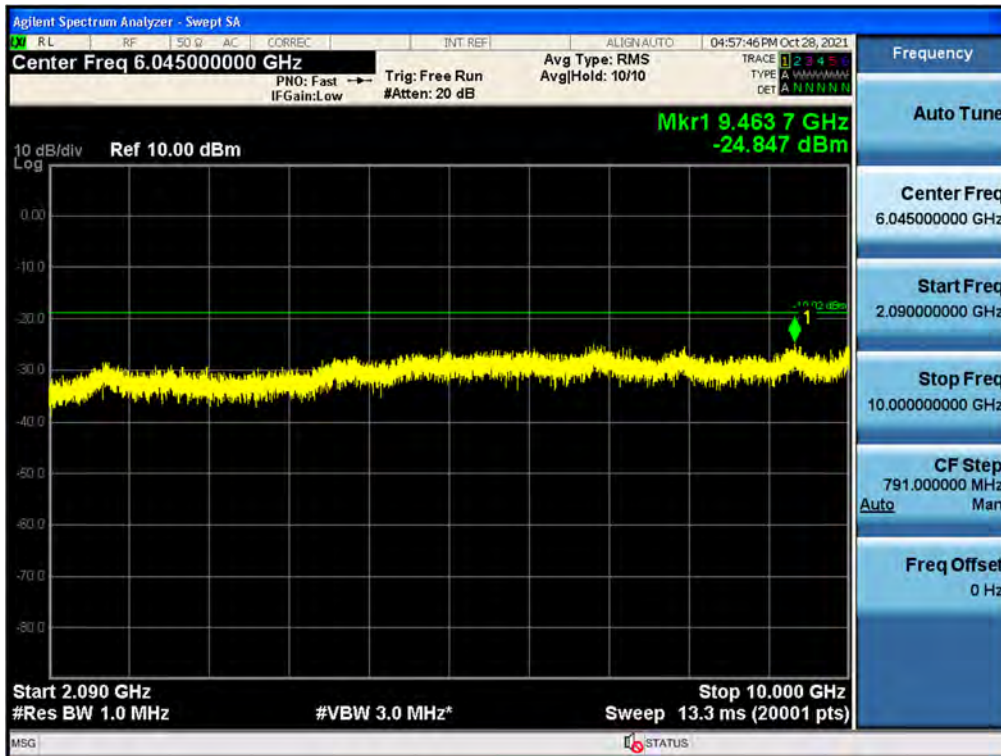

Antenna 1 / 10 GHz ~ 26.5 GHz / LTE B2 20 MHz 1 Carrier / 16QAM / High



## 5.6. RADIATED EMISSIONS

### Test Requirements:

#### § 2.1053 Measurements required: Field strength of spurious radiation.

- (a) Measurements shall be made to detect spurious emissions that may be radiated directly from the cabinet, control circuits, power leads, or intermediate circuit elements under normal conditions of installation and operation. Curves or equivalent data shall be supplied showing the magnitude of each harmonic and other spurious emission. For this test, single sideband, independent sideband, and controlled carrier transmitters shall be modulated under the conditions specified in paragraph (c) of § 2.1049, as appropriate. For equipment operating on frequencies below 890 MHz, an open field test is normally required, with the measuring instrument antenna located in the far-field at all test frequencies. In the event it is either impractical or impossible to make open field measurements (e.g. a broadcast transmitter installed in a building) measurements will be accepted of the equipment as installed. Such measurements must be accompanied by a description of the site where the measurements were made showing the location of any possible source of reflections which might distort the field strength measurements. Information submitted shall include the relative radiated power of each spurious emission with reference to the rated power output of the transmitter, assuming all emissions are radiated from halfwave dipole antennas.
- (b) The measurements specified in paragraph (a) of this section shall be made for the following equipment:
- (1) Those in which the spurious emissions are required to be 60 dB or more below the mean power of the transmitter.
  - (2) All equipment operating on frequencies higher than 25 MHz.
  - (3) All equipment where the antenna is an integral part of, and attached directly to the transmitter.
  - (4) Other types of equipment as required, when deemed necessary by the Commission.

#### § 24.238 Emission limitations for Broadband PCS equipment.

The rules in this section govern the spectral characteristics of emissions in the Broadband Personal Communications Service.

- (a) Out of band emissions. The power of any emission outside of the authorized operating frequency ranges must be attenuated below the transmitting power (P) by a factor of at least  $43 + 10 \log(P)$  dB.
- (b) Measurement procedure. Compliance with these rules is based on the use of measurement instrumentation employing a resolution bandwidth of 1 MHz or greater. However, in the 1 MHz bands immediately outside and adjacent to the frequency block a resolution bandwidth of at least one percent of the emission bandwidth of the fundamental emission of the transmitter may be employed. A narrower resolution bandwidth is permitted in all cases to improve measurement accuracy provided the measured power is integrated over the full required measurement bandwidth (i.e. 1 MHz or 1 percent of emission bandwidth, as specified). The emission bandwidth is defined as the width of the signal between two points, one below the carrier center frequency and one above the carrier center frequency, outside of which all emissions are attenuated at least 26 dB below the transmitter power.
- (c) Alternative out of band emission limit. Licensees in this service may establish an alternative out of band emission limit to be used at specified band edge(s) in specified geographical areas, in lieu of that set forth in this section, pursuant to a private contractual arrangement of all affected licensees and applicants. In this event, each party to such contract shall maintain a copy of the contract in their station files and disclose it to prospective assignees or transferees and, upon request, to the FCC.



- (d) Interference caused by out of band emissions. If any emission from a transmitter operating in this service results in interference to users of another radio service, the FCC may require a greater attenuation of that emission than

**Test Procedures:**

The measurement is performed in accordance with Section 5.5.3.2 of ANSI C63.26.

- a) Place the EUT in the center of the turntable. The EUT shall be configured to transmit into the standard non-radiating load (for measuring radiated spurious emissions), connected with cables of minimal length unless specified otherwise. If the EUT uses an adjustable antenna, the antenna shall be positioned to the length that produces the worst case emission at the fundamental operating frequency.
- b) Each emission under consideration shall be evaluated:
  - 1) Raise and lower the measurement antenna in accordance 5.5.2, as necessary to enable detection of the maximum emission amplitude relative to measurement antenna height.
  - 2) Rotate the EUT through 360° to determine the maximum emission level relative to the axial position.
  - 3) Return the turntable to the azimuth where the highest emission amplitude level was observed.
  - 4) Vary the measurement antenna height again through 1 m to 4 m again to find the height associated with the maximum emission amplitude.
  - 5) Record the measured emission amplitude level and frequency using the appropriate RBW.
- c) Repeat step b) for each emission frequency with the measurement antenna oriented in both the horizontal and vertical polarizations to determine the orientation that gives the maximum emissions amplitude.
- d) ~ j) Omitted
- k) Provide the complete measurement results as a part of the test report.

**Note:**

1. The results of the Radiated Emissions test shown above are measured at maximum power, and data values are attached only in the worst case.
2. The amplitude of the spurious domain emission attenuated by more than 20 dB over the permissible value was not recorded according to ANSI C63.26, clause 5.1.1., c).
3. Measure distance = 3 m

**Test Results:**

**B2 DSS 15 MHz 9to1 1 Carrier**

| Freq.(MHz) | Measured Level | Ant. Factor | A.G.+C.L.+H.P.F. | Pol. | Measured Power | Result |
|------------|----------------|-------------|------------------|------|----------------|--------|
|            | [dBuV]         |             |                  |      | [dBm]          |        |
| 5898.50    | 55.11          | 34.2        | 36.36            | V    | -40.09         | -42.25 |
| 6881.50    | 53.05          | 35.8        | 35.73            | V    | -42.15         | -42.08 |
| 12779.50   | 52.39          | 39.8        | 31.34            | V    | -42.81         | -34.35 |

\* C.L.: Cable Loss / A.G.: Amp Gain / H.P.F.: High Pass Filter

\*Result: (Measured Level – 95.2) + Ant. Factor – (A.G.+C.L.+H.P.F.)

**Plot data of Radiated Emissions**

**B2 DSS 15 MHz 9to1 1 Carrier**



**Note:** Only the worst case plots for Radiated Spurious Emissions.

## 5.7. FREQUENCY STABILITY

### Test Requirements:

#### § 2.1055 Measurements required: Frequency stability.

(a) The frequency stability shall be measured with variation of ambient temperature as follows:

- (1) From  $-30^{\circ}$  to  $+50^{\circ}$  centigrade for all equipment except that specified in paragraphs (a) (2) and (3) of this section.

#### § 24.235 Frequency stability.

The frequency stability shall be sufficient to ensure that the fundamental emission stays within the authorized frequency block.

#### § 27.54 Frequency stability.

The frequency stability shall be sufficient to ensure that the fundamental emissions stay within the authorized bands of operation.

### Test Procedures:

The measurement is performed in accordance with Section 5.6.3, 5.6.4 and 5.6.5 of ANSI C63.26.

#### 5.6.3 Procedure for frequency stability testing

Frequency stability is a measure of the frequency drift due to temperature and supply voltage variations, with reference to the frequency measured at  $+20^{\circ}\text{C}$  and rated supply voltage.

The operating carrier frequency shall be set up in accordance with the manufacturer's published operation and instruction manual prior to the commencement of these tests. No adjustment of any frequency determining circuit element shall be made subsequent to this initial set-up. Frequency stability is tested:

- a) At  $10^{\circ}\text{C}$  intervals of temperatures between  $-30^{\circ}\text{C}$  and  $+50^{\circ}\text{C}$  at the manufacturer's rated supply voltage, and
- b) At  $+20^{\circ}\text{C}$  temperature and  $\pm 15\%$  supply voltage variations. If a product is specified to operate over a range of input voltage then the  $-15\%$  variation is applied to the lowermost voltage and the  $+15\%$  is applied to the uppermost voltage.

During the test all necessary settings, adjustments and control of the EUT have to be performed without disturbing the test environment, i.e., without opening the environmental chamber. The frequency stabilities can be maintained to a lesser temperature range provided that the transmitter is automatically inhibited from operating outside the lesser temperature range. For handheld equipment that is only capable of operating from internal batteries and the supply voltage cannot be varied, the frequency stability tests shall be performed at the nominal battery voltage and the battery end point voltage specified by the manufacturer. An external supply voltage can be used and set at the internal battery nominal voltage, and again at the battery operating end point voltage which shall be specified by the equipment manufacturer.

If an unmodulated carrier is not available, the mean frequency of a modulated carrier can be obtained by using a frequency counter with gating time set to an appropriately large multiple of bit periods (gating time depending on the required accuracy). Full details on the choice of values shall be included in the test report.

#### 5.6.4 Frequency stability over variations in temperature

- a) Supply the EUT with a nominal 60 Hz ac voltage, dc voltage, or install a new or fully charged battery in the EUT.
- b) If possible a dummy load should be connected to the EUT because an antenna near the metallic walls of an environmental test chamber could affect the output frequency of the EUT. If the EUT is equipped with a permanently attached, adjustable-length antenna, the EUT should be placed in the center of the chamber with the antenna adjusted to the shortest length possible.
- c) Turn on the EUT, and tune it to the center frequency of the operating band.
- d) Couple the transmitter output to the measuring instrument through a suitable attenuator and coaxial cable. If connection to the EUT output is not possible, make the measurement by connecting an antenna to the measuring instrument with a suitable length of coaxial cable and placing the measuring antenna near the EUT (e.g., 15 cm away).

NOTE—An instrument that has an adequate level of accuracy as specified by the procuring or regulatory authority is the recommended measuring instrument.
- e) Adjust the location of the measurement antenna and the controls on the measurement instrument to obtain a suitable signal level (i.e., a level that will not overload the measurement instrument, but is strong enough to allow measurement of the operating or fundamental frequency of the EUT). Adjust the detector bandwidth and span settings to achieve a resolution capable of accurate frequency measurements over the applicable frequency stability limits.
- f) Turn the EUT off, and place it inside the environmental temperature chamber. For devices that have oscillator heaters, energize only the heater circuit.
- g) Set the temperature control on the chamber to the Highest temperature specified in the regulatory requirements for the type of device, and allow the oscillator heater and the chamber temperature to stabilize. Unless otherwise instructed by the regulatory authority, this temperature should be 50 °C.
- h) While maintaining a constant temperature inside the environmental chamber, turn on the EUT and allow sufficient time for the EUT temperature to stabilize.
- i) Measure the frequency.
- j) Switch off the EUT, but do not switch off the oscillator heater.
- k) Lower the chamber temperature to the next level that is required by the standard and allow the temperature inside the chamber to stabilize. Unless otherwise instructed by the regulators, this temperature step should be 10 °C.
- l) Repeat step h) through step k) down to the lowest specified temperature. Unless otherwise instructed by the regulators, this temperature should be –30 °C. When the frequency stability limit is stated as being sufficient such that the fundamental emissions stay within the authorized bands of operation, a reference point shall be established at the applicable unwanted emissions limit using a RBW equal to the RBW required by the unwanted emissions specification of the applicable regulatory standard. These reference points measured using the lowest and Highest channel of operation shall be identified as  $f_L$  and  $f_H$  respectively. The worst-case frequency offset determined in the above methods shall be added or subtracted from the values of  $f_L$  and  $f_H$  and the resulting frequencies must remain within the band.
- m) Omitted

### 5.6.5 Frequency stability when varying supply voltage

- a) Couple the transmitter output to the measuring instrument through a suitable attenuator and coaxial cable. If connection to the EUT output is not possible make the measurement by connecting an antenna to the measuring instrument with a suitable length of coaxial cable and placing the measuring antenna near the EUT (e.g., 15 cm away)
- b) Supply the EUT with nominal ac or dc voltage. The supply voltage shall be measured at the input to the cable normally provided with the equipment, or at the power supply terminals if cables are not normally provided. Effects on frequency of transmitter keying (except for broadcast transmitters) and any heating element cycling at the nominal supply voltage and at each extreme also shall be shown.
- c) Turn on the EUT, and couple its output to a frequency counter or other frequency-measuring instrument.
- d) Tune the EUT to the center frequency of the operating band. Adjust the location of the measurement antenna and the controls on the measurement instrument to obtain a suitable signal level (i.e., a level that will not overload the measurement instrument, but is strong enough to allow measurement of the operating or fundamental frequency of the EUT). Adjust the detector bandwidth and span settings to achieve a resolution capable of accurate frequency measurements over the applicable frequency stability limits.

NOTE—An instrument that has an adequate level of accuracy as specified by the procuring or regulatory authority is the recommended measuring instrument.

- e) Measure the frequency.
- f) Unless otherwise specified, vary primary supply voltage from 85% to 115% of the nominal value for other than hand carried battery equipment.
- g) For hand carried, battery powered equipment, reduce the primary ac or dc supply voltage to the battery operating end point, which shall be specified by the manufacturer.
- h) Repeat the frequency measurement.

NOTE—For band-edge compliance, it can be required to make these measurements at the low and High channel of the operating band.

**Note:** The results of the frequency stability test shown above the frequency deviation measured values are very small and similar trend for each port, so we are attached only the worst case data.

**Test Results:**
**PCS**
**Reference: - 48 Vdc at 20°C Freq. = 1,960,000,000 Hz**

| Voltage (%) | Temp. (°C) | Frequency (Hz) | Frequency Error (Hz) | Deviation (Hz) | ppm      |
|-------------|------------|----------------|----------------------|----------------|----------|
| 100%        | +20(Ref)   | 1960 000 002   | 1.991                | 0.000          | 0.00000  |
|             | -30        | 1960 000 006   | 4.076                | 2.084          | 0.00106  |
|             | -20        | 1960 000 008   | 5.916                | 3.924          | 0.00200  |
|             | -10        | 1960 000 008   | 6.421                | 4.430          | 0.00226  |
|             | 0          | 1960 000 007   | 5.484                | 3.492          | 0.00178  |
|             | +10        | 1960 000 002   | 0.429                | -1.563         | -0.00080 |
|             | +30        | 1960 000 007   | 4.595                | 2.604          | 0.00133  |
|             | +40        | 1960 000 012   | 9.708                | 7.716          | 0.00394  |
|             | +50        | 1960 000 004   | 2.215                | 0.224          | 0.00011  |
| 115%        | +20        | 1960 000 009   | 6.827                | 4.835          | 0.00247  |
| 85%         | +20        | 1960 000 009   | 7.166                | 5.174          | 0.00264  |

**Note:** The results of the frequency stability test shown above the frequency deviation measured values are very small and similar trend for each port, so attached datas were only the port 0.

## 6. Annex B\_EUT AND TEST SETUP PHOTO

Please refer to test setup photo file no. as follows;

| No. | Description         |
|-----|---------------------|
| 1   | HCT-RF-2110-FC021-P |