

## Nemko Korea CO., Ltd.

300-2, Osan-Ri, Mohyeon-Myeon, Cheoin-Gu, Yongin-Si, Gyeonggi-Do, KOREA

TEL:+82 31 322 2333

FAX:+82 31 322 2332

### FCC and IC EVALUATION REPORT FOR CERTIFICATION

**Applicant :**

**Samsung Electronics Co., Ltd.**  
416, Maetan-3Dong, Yeongtong-Gu,  
Suwon-Si, Gyeonggi-Do, Korea.  
(Post code : 443-742)  
Attn. : Mr. Jay-woo, Lee

**Dates of Issue : October 12, 2009**  
**Test Report No. : NK09R151**  
**Test Site : Nemko Korea Co., Ltd.**

**FCC ID**  
**IC ID**

**A3LPS10PS**  
**649E-PS10PS**

**Brand Name**

**SAMSUNG**

**Contact Person**

**Samsung Electronics Co., Ltd.**  
416, Maetan-3Dog, Yeongtong-Gu,  
Suwon-Si, Gyeonggi-Do, Korea, 442-742.  
Mr. Jaywoo. Lee  
Telephone No. : +82-10-5691-9410

Applied Standard: FCC 47 CFR Part 15C and IC RSS-210  
Classification: FCC part 15 Spread Spectrum Transmitter  
EUT Type: Photo Player

The device bearing the brand name and model specified above has been shown to comply with the applicable technical standards as indicated in the measurement report and was tested in accordance with the measurement procedures specified in ANSI C63.4-2003. The client should not use it to claim product endorsement by TAF or any government agencies. The test results in the report only apply to the tested sample.

I attest to the accuracy of data and all measurements reported herein were performed by me or were made under my supervision and are correct to the best of my knowledge and belief. I assume full responsibility for the completeness of these measurements and vouch for the qualifications of all persons taking them.



Tested By : Minchul Shin  
Engineer



Reviewed By : H.H. Kim  
Manager & Chief Engineer

# TABLE OF CONTENTS

---

<b>1. Scope</b>	<b>4</b>
<b>2. Introduction (Site Description)</b>	<b>5</b>
<b>3. Test Conditions &amp; EUT Information</b>	<b>6</b>
3.1 Operation During Test	6
3.2 Support Equipment	6
3.3 EUT Information	6
<b>4. Summary of Test Results</b>	<b>8</b>
<b>5. Recommendation / Conclusion</b>	<b>9</b>
<b>6. Antenna Requirements</b>	<b>9</b>
<b>7. Description of Test</b>	<b>10</b>
7.1 Conducted Emissions	10
7.2 Radiated Emissions	11
7.3 20 dB Bandwidth and Carrier Frequency Separation	12
7.4 Transmitter Average Time of Occupancy	12
7.5 Number of Hopping Channels	13
7.6 Maximum Peak Output Power	13
7.7 Conducted Spurious Emissions	14
<b>8. Test Data</b>	<b>15</b>
8.1 Conducted Emissions	15
8.2 Radiated Emissions	18
8.3 20 dB Modulated Bandwidth	19
8.4 Carrier Frequency Separation	23
8.5 Transmitter Average Time of Occupancy	25
8.6 Number of Hopping Channels	28
8.7 Peak Power Output	30
8.8 Conducted Spurious Emissions	34

8.9 Radiated Spurious Emissions	43
8.10 Receiver Spurious Emission	49
<b>9 Maximum Permissible Exposure</b>	<b>50</b>
<b>10 Accuracy of Measurement</b>	<b>52</b>
<b>11. Test Equipment</b>	<b>53</b>
<b>Appendix A: Labelling Requirement</b>	<b>54</b>
<b>Appendix B: Photographs of Test Set-up</b>	<b>55</b>
<b>Appendix C: EUT Photographs</b>	<b>56</b>

## 1. SCOPE

---

Measurement and determination of electromagnetic emissions (EME) of radio frequency devices including intentional and/or unintentional radiators for compliance with the technical rules and regulations of the Federal Communications Commission under FCC part 15 and IC RSS-210.

<b>Responsible Party :</b>	Samsung Electronics Co., Ltd.
<b>Contact Person :</b>	Mr. Jaywoo. Lee
<b>Manufacturer :</b>	Samsung Electronics Co., Ltd. 416 Maetan-3Dong, Yeongtong-Gu, Suwon-Si, Gyeonggi-Do, 443-742 KOREA

- FCC ID: A3LPS10PS
- Model: PS10PS
- Brand Name: SAMSUNG
- EUT Type: Photo Player
- Classification: FCC Class B
- Applied Standard: FCC 47 CFR Part 15 subpart C and IC RSS-210
- Test Procedure(s): ANSI C63.4 (2003)
- Dates of Test: Sep. 2, 2009 ~ Oct. 8, 2009
- Place of Tests: Nemko Korea Co., Ltd.

## 2. INTRODUCTION

The measurement procedure described in American National Standard for Methods of Measurement of Radio-Noise Emissions from Low-Voltage Electrical and Electronic Equipment in the Range of 9kHz to 40GHz (ANSI C63.4-2003) was used in determining radiated and conducted emissions emanating from **Samsung Electronics Co., Ltd.**

FCC ID : **A3LPS10PS** and IC ID : **649E-PS10PS**

These measurement tests were conducted at **Nemko Korea Co., Ltd. EMC Laboratory**.

The site address is 300-2, Osan-Ri, Mohyeon-Myeon, Cheoin-Gu, Yongin-Si, Gyeonggi-Do, KOREA.

The area of Nemko Korea Corporation Ltd. EMC Test Site is located in a mountain area at 80 kilo-meters (48 miles) southeast and Incheon International Airport (Incheon Airport), 30 kilometers (18miles) south-southeast from central Seoul.

It is located in the valley surrounded by mountains in all directions where ambient radio signal conditions are quiet and a favorable area to measure the radio frequency interference on open field test site for the computing and ISM devices manufactures.

The detailed description of the measurement facility was found to be in compliance with the requirements of § 2.948 according to ANSI C63.4 2003.

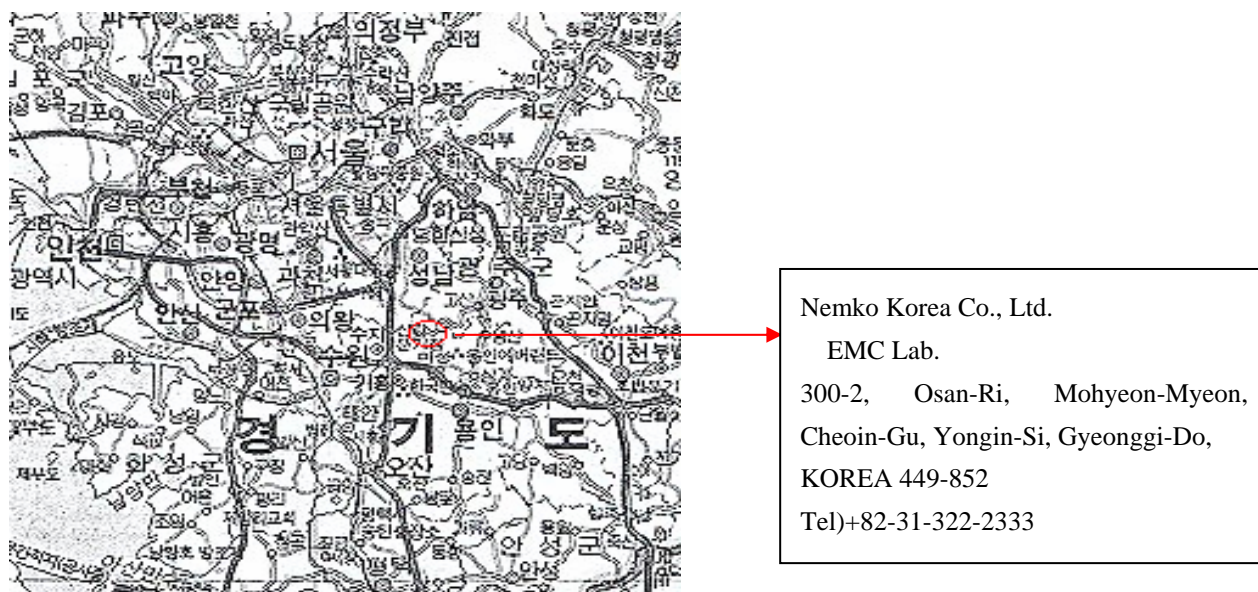

Fig. 1. The map above shows the Seoul in Korea vicinity area.  
The map also shows Nemko Korea Corporation Ltd. EMC Lab. and Incheon Airport.

### 3. TEST CONDITIONS & EUT INFORMATION

#### 3.1 Operation During Test

The EUT was Controlled and monitored by CSR Bluetest testing program which manufacturer supported through USB cable with Notebook computer.

The EUT was supplied from the DC power supply according to the manufacturer's request.

The test was performed at the Lowest, Middle, Highest channel.

For the Maximum Peak output power, Carrier Frequency separation, 20 dB Bandwidth, Band Edge tests were tested with both GFSK and 8DPSK modulation.

For the Radiation test was tested with GFSK modulation mode which was the worst case.

#### 3.2 Support Equipment

<p>Photo Player (EUT)</p>	<p>Samsung Electronics Co., Ltd. FCC ID: A3LPS10PS</p> <p>Adaptor : Samsung Model: SAD1212 1.5m shielded DC cable 0.9m Unshielded Ac Cable</p>	<p>S/N: N/A</p> <p>S/N: KR06BN4400133CDC07D7E0097</p>
<p>Notebook Computer</p>	<p>Samsung Electronics Model: NT-R520</p> <p>Adaptor : Chicony Power Technology Co.,Ltd. Model : CPA09-004A 1.7m shielded DC cable, 0.7m unshielded AC cable.</p>	<p>S/N: ZK6V93FS800012Y</p> <p>S/N: CNBA4400242ADON89712602</p>

#### 3.3 EUT Information

The EUT is the **Samsung Photo Player with Bluetooth FCC ID: A3LPS10PS, IC ID: 649E-PS10PS**. This unit supports full qualified Bluetooth v2.0 with EDR system.

This Bluetooth module in the Samsung Photo Player has been tested by a Bluetooth Qualification Lab, and we confirm the following:

- The hopping sequence is pseudorandom
- All channels are used equally on average
- The receiver input bandwidth equals the transmit bandwidth
- The receiver hops in sequence with the transmit signal

15.247(g) : In accordance with the Bluetooth industry Standard, the system is designed to comply with all of the regulations in Section 15.247 when the transmitter is presented with a continuous data (or information)stream.

15.247(h) : In accordance with the Bluetooth Industry Standard, the system does not coordinate its channels selection/hopping sequence with other frequency hopping systems for the express purpose of avoiding the simultaneous occupancy of individual hopping frequencies by multiple transmitters.

Specifications:

RF Frequency	2402 ~ 2480 MHz
Channel Number	79
Modulation	GFSK, 8DPSK
RF output power	5.72 dBm (EIRP)
Power	Adaptor(Input: (100-240) Vac, Output:12 Vdc, 1 A)
Size	280.0 mm x 188.0 mm x 23.0 mm
Weight	750 g

## 4. SUMMARY OF TEST RESULTS

The EUT has been tested according to the following specification:

<b>Name of Test</b>	<b>FCC Paragraph No.</b>	<b>IC Paragraph No.</b>	<b>Result</b>	<b>Remark</b>
Conducted Emission	15.207	RSS-GEN	Complies	
Radiated Emission	15.209	RSS-210 Clause 2.6, RSS-GEN Clause 6	Complies	
20dB Bandwidth and Carrier Frequency Separation	15.247(a)(1)	RSS-210 A8.1 (b)	Complies	
Transmitter Average Time of Occupancy	15.247(a)(1)(iii)	RSS-210 A8.1(d)	Complies	
Peak Power Output	15.247(b)(1)	RSS-210 Issue 7 Clause A8.4	Complies	
Conducted Spurious Emission	15.247(d)	IC RSS-210 A8.5	Complies	
Radiated Spurious Emission	15.247(d)	RSS-210 Clause 2.6, RSS-GEN Clause 6	Complies	
Number of Hopping channels	15.247(a)(1)(iii)	RSS-210 A8.1(d)	Complies	
Maximum Permissible Exposure	1.1307(b)	RSS-102	Complies	

## 5. RECOMMENDATION/CONCLUSION

---

The data collected shows that the **Samsung Photo Player with Bluetooth FCC ID: A3LPS10PS, IC ID: 649E-PS10PS** is in compliance with Part 15 Subpart C 15.247 of the FCC Rules.

## 6. ANTENNA REQUIREMENTS

---

### §15.203 of the FCC Rules part 15 Subpart C

: An intentional radiator shall be designed to ensure that no antenna other than that furnished by the responsible party shall be used with the device. The use of a permanently attached antenna or of an antenna that uses a unique coupling to the intentional radiator shall be considered sufficient to comply with the provisions of this section.

The antenna of the **Samsung Photo Player with Bluetooth FCC ID: A3LPS10PS, IC ID: 649E-PS10PS** is **Permanently attached** and there are no provisions for connection to an external antenna. It complies with the requirement of §15.203.

## 7. DESCRIPTION OF TESTS

### 7.1 Conducted Emissions

The Line conducted emission test facility is located inside a 4 X 7 X 2.5 meter shielded enclosure. It is manufactured by EM engineering. The shielding effectiveness of the shielded room is in accordance with MIL-STD-285 or NSA 65-6.

A 1m X 1.5m wooden table 0.8m height is placed 0.4m away from the vertical wall and 1.5m away from the side of wall of the shielded room Rohde & Schwarz (ESH3-Z5) and Kyoritsu (KNW-407) of the 50ohm/50uH Line Impedance Stabilization Network(LISN) are bonded to the shielded room. The EUT is powered from the Rohde & Schwarz LISN and the support equipment is powered from the Kyoritsu LISN. Power to the LISN s are filtered by high-current high insertion loss Power line filters. The purpose of filter is to attenuate ambient signal interference and this filter is also bonded to shielded enclosure. All electrical cables are shielded by tinned copper zipper tubing with inner diameter of 1/2".

If DC power device, power will be derived from the source power supply it normally will be powered from

and this supply lines will be connected to the LISNs, All interconnecting cables more than 1 meter were shortened by non inductive bundling (serpentine fashion) to a 1 meter length.

Sufficient time for EUT, support equipment, and test equipment was allowed in order for them to warm up to their normal operating condition. The RF output of the LISN was connected to the spectrum analyzer to determine the frequency producing the maximum EME from the EUT.

The spectrum was scanned from 150 kHz to 30 MHz with 200 msec sweep time.

The frequency producing the maximum level was re-examined using the EMI test receiver. (Rohde & Schwarz ESCS30).

The detector function were set to CISPR quasi-peak mode & average mode.

The bandwidth of receiver was set to 9KHz. The EUT, support equipment, and interconnecting cables were arranged and manipulated to maximize each EME emission.

Each emission was maximized by; switching power lines; varying the mode of operation or resolution; clock or data exchange speed; scrolling H pattern to the EUT and of support equipment, and powering the monitor from the floor mounted outlet box and computer aux AC outlet, if applicable; which ever determined the worst case emission.

Each EME reported was calibrated using the R&S signal generator.

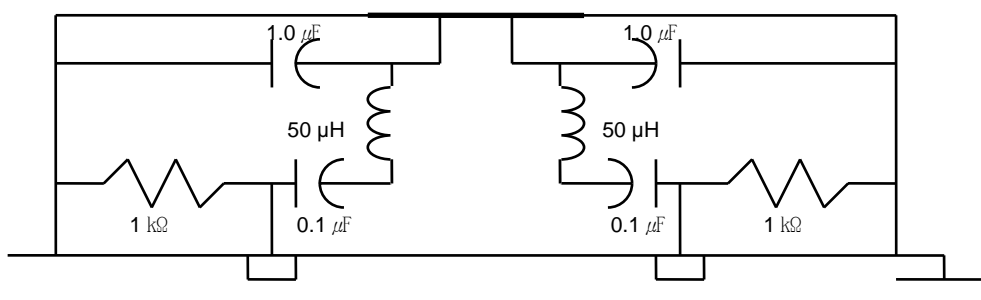

Fig. 2. LISN Schematic Diagram

## 7.2 Radiated Emissions

Preliminary measurement were made indoors at 3 meter using broad band antennas, broadband amplifier, and spectrum analyzer to determine the frequency producing the maximum EME. Appropriate precaution was taken to ensure that all EME from the EUT were maximized and investigated. The Technology configuration, clock speed, mode of operation or video resolution, turntable azimuth with respect to the antenna was note for each frequency found. The spectrum was scanned from 9 kHz to 30 MHz using Loop Antenne(EMCO, 6502) and 30 to 1000 MHz using Bi-conical log Antenna(ARA, LPB-2520/A). Above 1 GHz, Horn antenna (Scwarzbeck BBHA 9120D: upto 18 GHz) was used. Final Measurements were made outdoors at 3 or 10 m test range using Loop Antenne(EMCO, 6502) and Logbicon Super Antenna (Schwarzbeck, VULB9166) or Horn antenna.( Scwarzbeck BBHA 9120D: upto 18 GHz , BBHA9170 : upto 40 GHz).

The test equipment was placed on a wooden table. Sufficient time for the EUT, support equipment, and test equipment was allowed in order for them to warm up to their normal operating condition. Each frequency found during pre-scan measurements was reexamined and investigated using EMI test receiver.(ESCS30) The detector function was set to CISPR peak mode or quasi-peak mode or average mode and the band-width of the receiver was set to 120 kHz or 1MHz depending on the frequency or type of signal. The half wave dipole antenna was tuned to the frequency found during preliminary radiated measurements. The EUT support equipment and interconnecting cables were re configured to the setup producing the maximum emission for the frequency and were placed on top of a 0.8 m high non- metallic 1.0 X 1.5 meter table. The EUT, support equipment and interconnecting cables were re-arranged and manipulated to maximize each EME emission. The turn table containing the Technology was rotated; the antenna height was varied 1 to 4meter and stopped at the azimuth or height producing the maximum emission Each emission was maximized by : switching power lines; varying the mode of operation or resolution; clock or data exchange speed; scrolling H pattern to the EUT and of support equipment, and powering the monitor from the floor mounted outlet box and computer aux AC outlet, if applicable; which ever determined the worst case emission.

Each EME reported was calibrated using the R/S signal generator.

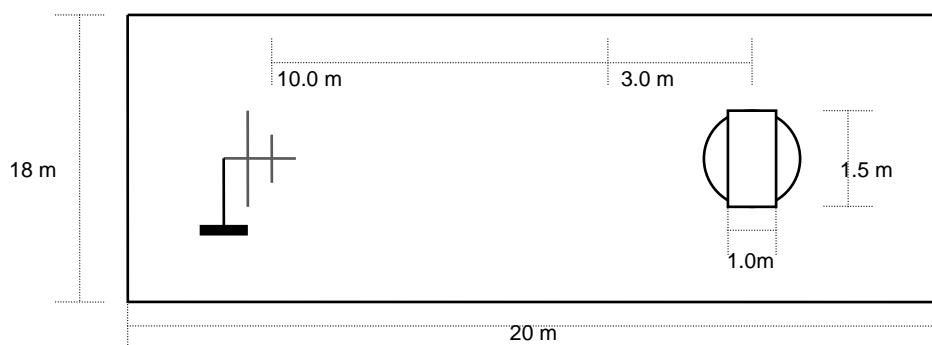
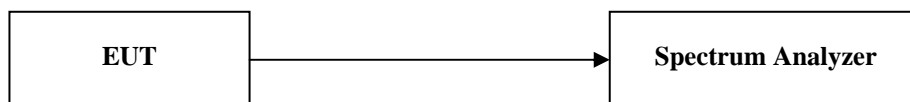

Fig. 3. Dimensions of Outdoor Test Site

### 7.3 20 dB Bandwidth and Carrier Frequency Separation

#### Test Setup



#### Test Procedure

The transmitter is set to the Low , Middle, High channels is connected to the spectrum analyzer. The RBW of spectrum analyzer is set to 30 kHz and VBW is set to the 100 kHz. The sweep time is coupled.

The spectrum analyzer is set for peak detected and Max hold scan mode.

When Carrier Frequency separation is tested, Frequency hopping is set.

### 7.4 Transmitter Average Time of Occupancy

#### Test Setup

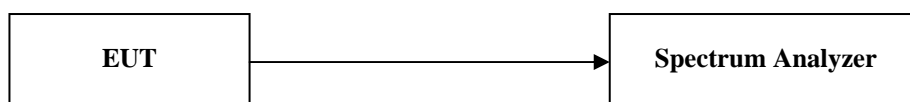

#### Test Procedure

The transmitter output is connected to a spectrum analyzer. The span is set to zero, centered on a single, selected hopping channel.

The width of a single pulse is measured in a fast scan. The number of pulses is measured in 3.16 second scan, to enable resolution of each occurrence.

The average time of occupancy in the specified 31.6 second period (79 channel x 0.4 second) is equal to 10 x number of pulses in 3.16 second x pulse width.

### 7.5 Number of Hopping Channels

#### Test Setup



#### Test Procedure

The transmitter output is connected to a spectrum analyzer. The span is set to cover the entire authorized band, In either a single sweep or in multiple continuous sweeps. The RBW is set to 1% of the span.

The spectrum analyzer is set to Max Hold.

### 7.6 Maximum Peak Output Power

#### Test Setup

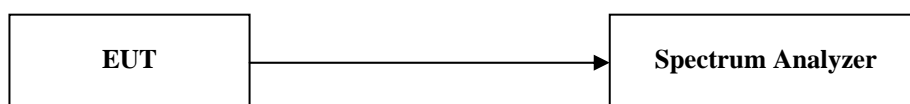

#### Test Procedure

The transmitter is set to the Low , Middle, High channels is connected to the spectrum analyzer. The RBW of spectrum analyzer is set to 3 MHz and VBW is set to the 3 MHz. The sweep time is coupled.

## 7.7 Conducted Spurious Emission

### Test Setup

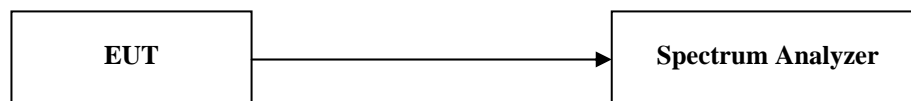

### Test Procedure

The transmitter is connected to the spectrum analyzer.

The RBW of spectrum analyzer is set to 100 kHz and VBW is set to the 100 kHz.

Measurements are made over the 30 MHz to 25 GHz range with the transmitter set to the Lowest, Middle and highest channels.

## 8. TEST DATA

### 8.1 Conducted Emissions

FCC §15.207

Location in the range of operation (near middle)

Frequency (MHz)	Level(dB $\mu$ V)		Line	Limit(dB $\mu$ V)		Margin(dB)	
	Q-Peak	Average		Q-Peak	Average	Q-Peak	Average
0.18	51.5	42.3	L	64.5	54.5	13.0	12.2
0.19	50.4	39.3	L	64.0	54.0	13.6	14.7
0.25	42.6	31.8	L	61.8	51.8	19.2	20.0
0.26	42.6	31.5	N	61.4	51.4	18.8	19.9
2.18	41.1	29.1	N	56.0	46.0	14.9	16.9
9.56	42.0	33.1	L	60.0	50.0	18.0	16.9

Line Conducted Emissions Tabulated Data

**NOTES:**

1. Measurements using CISPR quasi-peak mode and average mode.
2. All modes of operation were investigated and the worst -case emission are reported. See attached Plots.
3. The limit for an intentional radiator that is designed to be connected to the public utility (AC) power line is on the FCC part section 15.207 (a).
4. LINE : L = Line , N = Neutral

# PLOTS OF EMISSIONS

- Conducted Emission at the Mains port (Line)

NEMKO KOREA

11 Sep 2009 16:35

Conducted Emissions

EUT: EUT  
 Manuf: SAMSUNG Electronics  
 Op Cond: a.c. 120 V / 60 Hz  
 Operator: Min-chul, Shin  
 Test Spec: FCC Part 15 Subpart C  
 Comment: MODEL : PS10PS  
 LINE : LINE-PE  
 Result File: PS10PS\_I.dat : SAMSUNG\_PS10PS

Scan Settings		(1 Range)			Receiver Settings				
Start	Stop	Step	IF BW	Detector	M-Time	Atten	Preamp	OpRge	
150kHz	30MHz	3.9063kHz	9kHz	PK+AV	20msec	10 dB	OFF	60dB	
Transducer	No.	Start	Stop	Name					
	2	150kHz	30MHz	CE_LINE					
Final Measurement:									
		Detectors:	X QP / + AV						
		Meas Time:	1sec						
		Subranges:	8						
		Acc Margin:	60 dB						

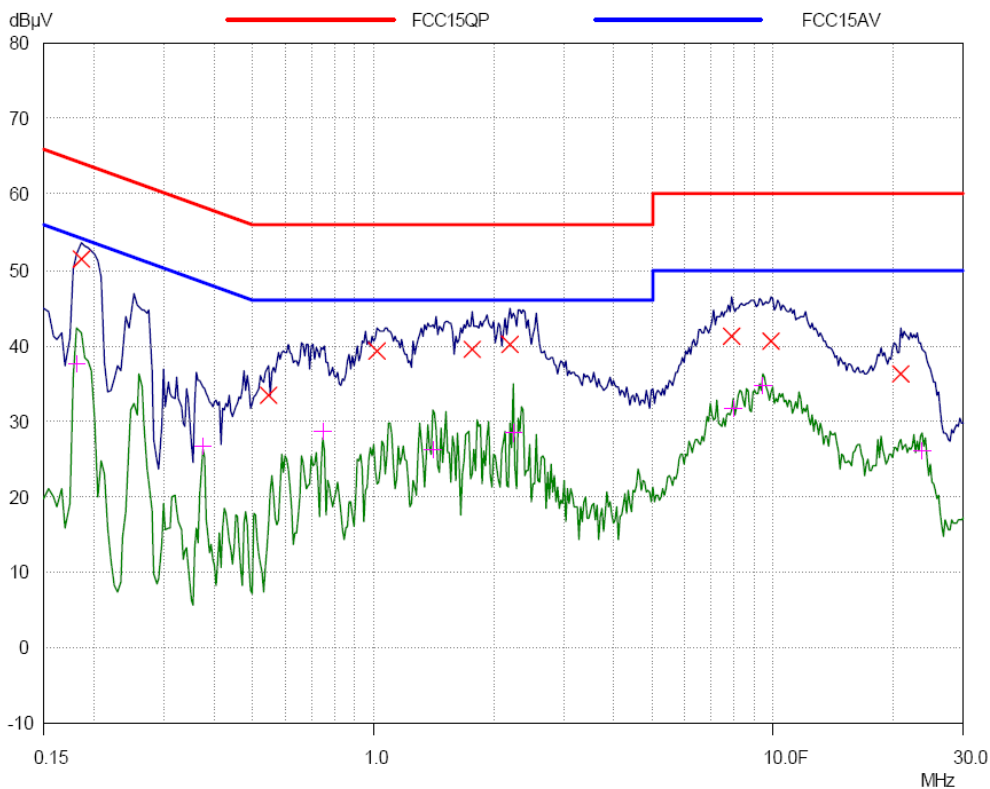

# PLOTS OF EMISSIONS

- Conducted Emission at the Mains port (Neutral)

NEMKO KOREA

11 Sep 2009 16:48

## Conducted Emissions

EUT: EUT  
 Manuf: SAMSUNG Electronics  
 Op Cond: a.c. 120 V / 60 Hz  
 Operator: Min-chul, Shin  
 Test Spec: FCC Part 15 Subpart C  
 Comment: MODEL : PS10PS  
 LINE : NEUTRAL-PE  
 Result File: PS10PS\_n.dat : SAMSUNG\_PS10PS

Scan Settings		(1 Range)			Receiver Settings				
Start	Stop	Step	IF BW	Detector	M-Time	Atten	Preamp	OpRge	
150kHz	30MHz	3.9063kHz	9kHz	PK+AV	20msec	10 dB	OFF	60dB	
Transducer	No.	Start	Stop	Name					
	1	150kHz	30MHz	CE_NEUT					
Final Measurement:		Detectors: X QP / + AV							
		Meas Time: 1sec							
		Subranges: 8							
		Acc Margin: 60 dB							

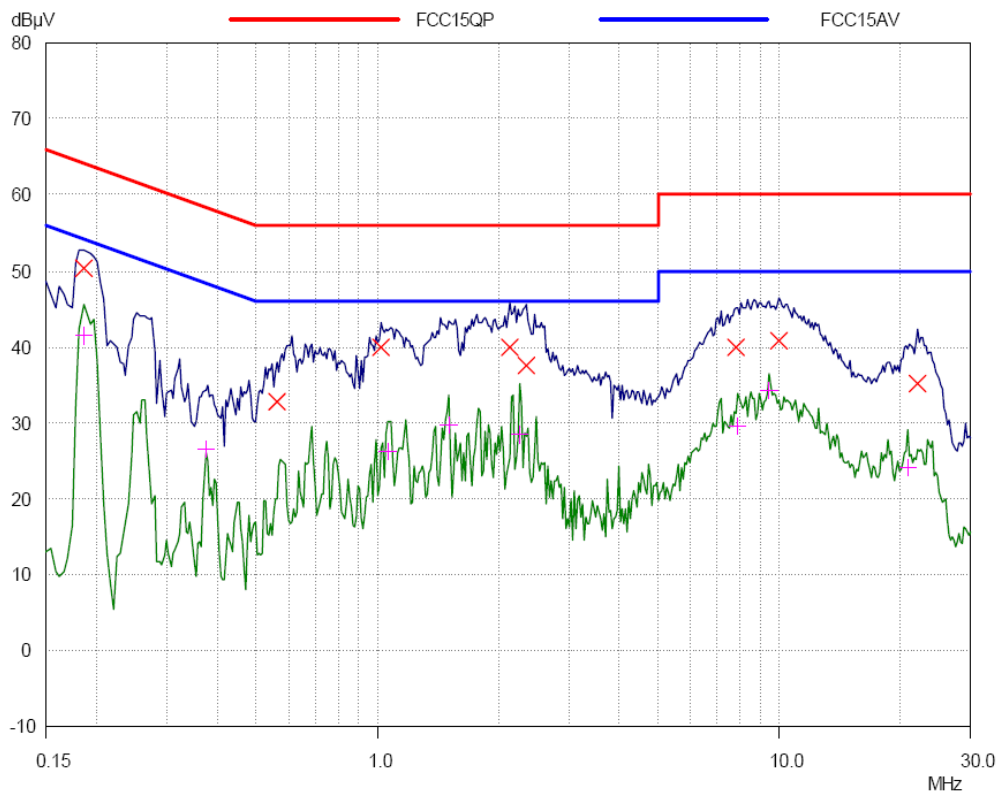

# TEST DATA

## 8.2 Radiated Emissions

FCC §15.209, IC RSS-210 Clause 2.6, IC RSS-GEN Clause 6

Frequency (MHz)	Reading (dB $\mu$ V/m)	Pol* (H/V)	AF+CL+Amp (dB)**	Result (dB $\mu$ V/m)	Limit (dB $\mu$ V/m)	Margin (dB)
90.25	56.5	H	-20.7	35.8	43.5	7.7
133.18	48.9	V	-17.1	31.8	43.5	11.7
136.43	51.3	V	-17.1	34.2	43.5	9.3
222.09	54.1	V	-19.1	35.0	46.0	11.0
227.99	55.3	V	-19.1	36.2	46.0	9.8
959.95	37.3	H	-1.3	36.0	46.0	10.0

Radiated Measurements at 3meters

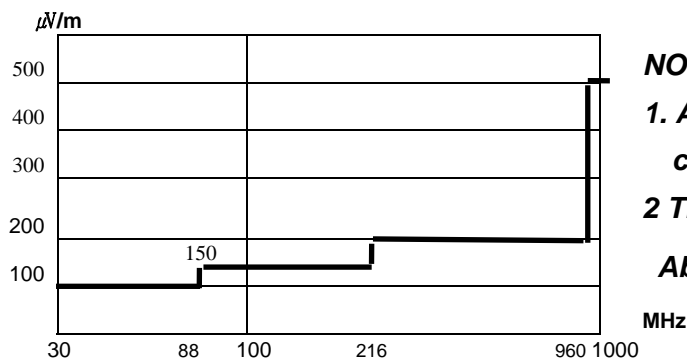

Fig. 4. Limits at 3 meters

**NOTES:**

1. All modes were measured and the worst-case emission was reported.
  - 2 The radiated limits are shown on Figure 4.
- Above 1GHz the limit is 500  $\mu$ V/m.

**NOTES:**

1. \*Pol. H=Horizontal, V=Vertical
2. \*\*AF+CL+Amp. = Antenna Factor + Cable Loss + Amplifier.
3. Measurements using CISPR quasi-peak mode.
4. The limit for the level of any unwanted emissions from an intentional radiator device is on the FCC Part section 15.209(a).
5. GFSK modulation mode is the worst condition.

## TEST DATA

---

### 8.3 20 dB Modulated Bandwidth

FCC §15.247(a), IC RSS-210 A8.1(b)

Test Mode : Set to Lowest channel, Middle channel and Highest channel

Result:

Modulation Mode	Frequency(MHz)	Result(KHz)	Limit(KHz)
GFSK	2402	942	Non specified
GFSK	2441	946	Non specified
GFSK	2480	946	Non specified
8DPSK	2402	1262	Non specified
8DPSK	2441	1267	Non specified
8DPSK	2480	1262	Non specified

## PLOTS OF EMISSIONS

### 20 dB Bandwidth, Lowest Channel (2402 MHz, GFSK Mode)

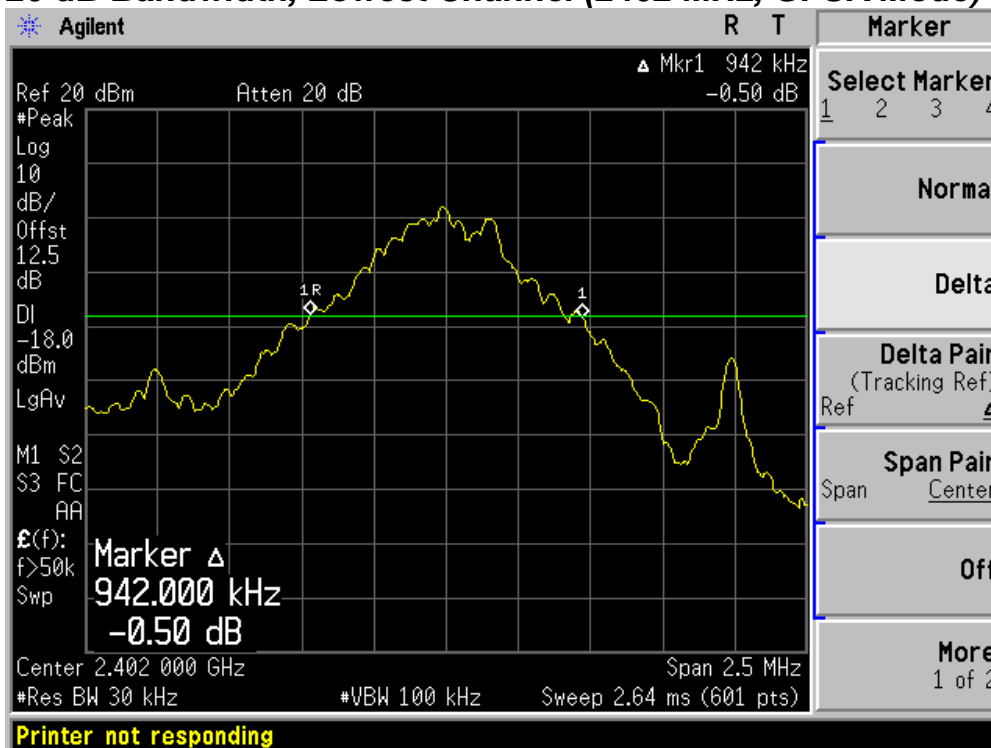

### 20 dB Bandwidth, Lowest Channel (2402 MHz, 8DPSK Mode)

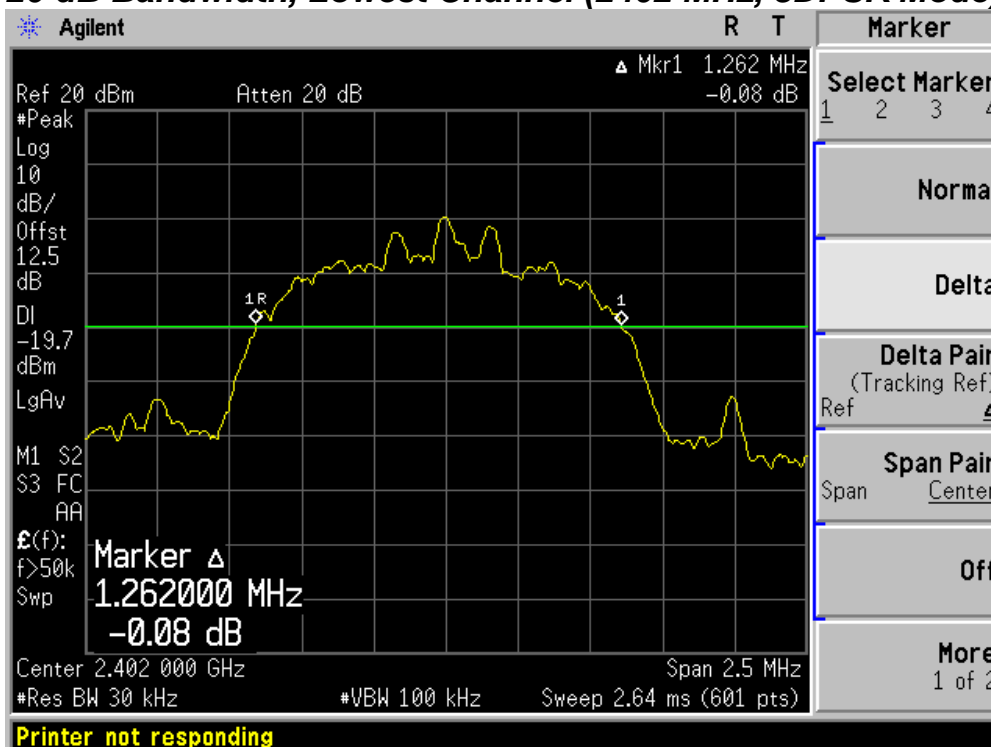

## PLOTS OF EMISSIONS

### 20 dB Bandwidth, Middle Channel (2441 MHz, GFSK Mode)

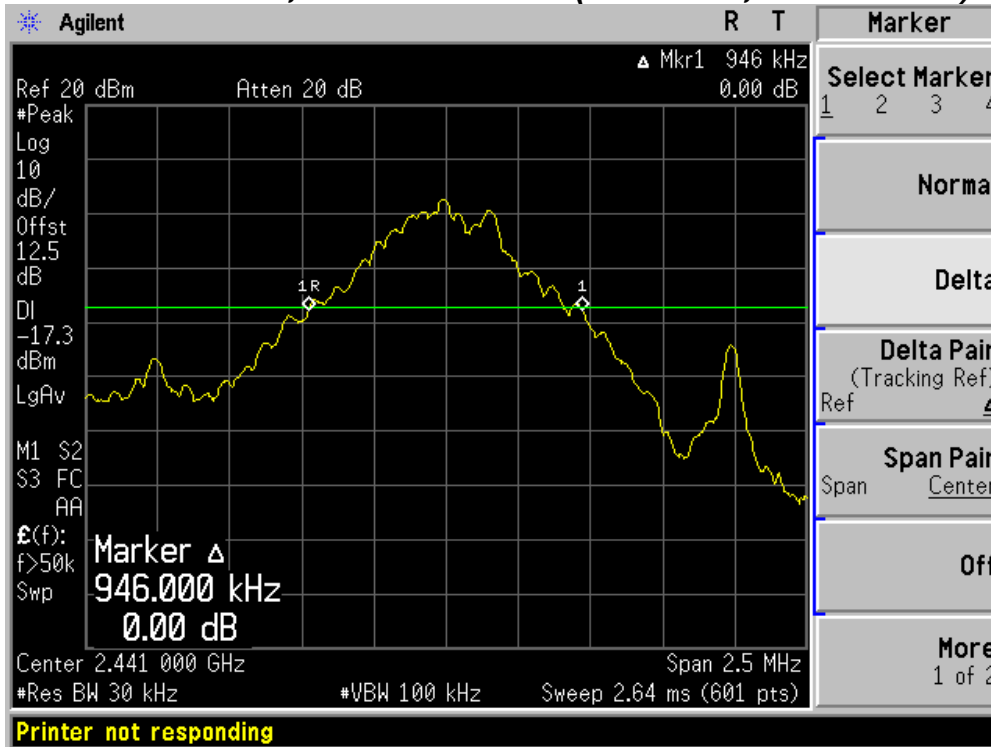

### 20 dB Bandwidth, Middle Channel (2441 MHz, 8DPSK Mode)

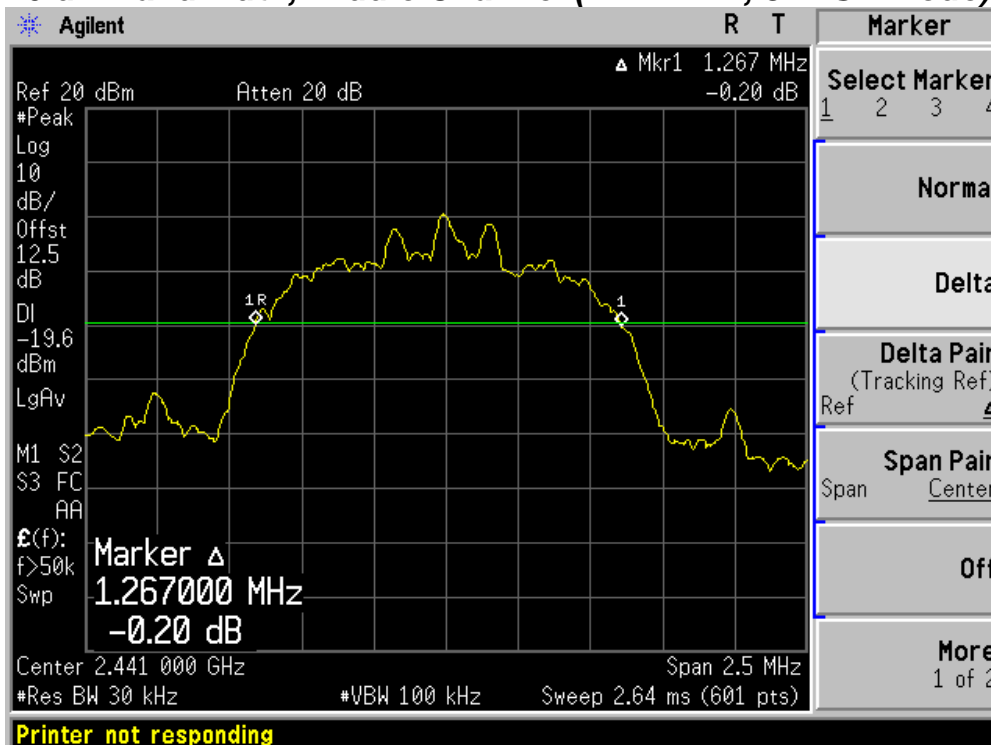

## PLOTS OF EMISSIONS

### 20 dB Bandwidth, Highest Channel (2480 MHz, GFSK Mode)

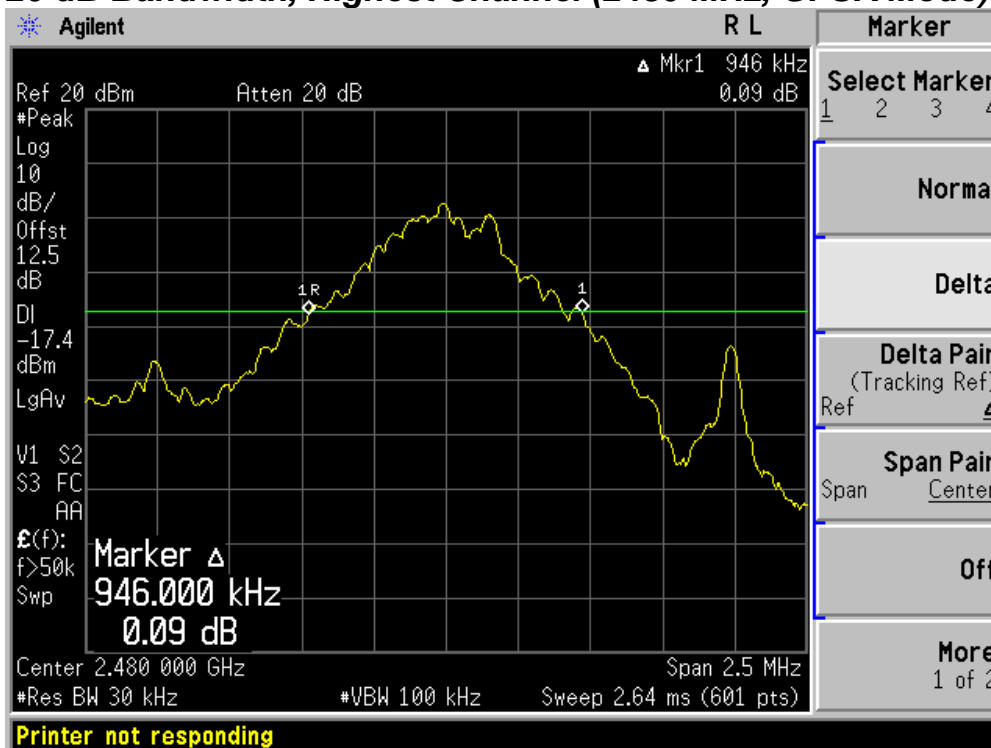

### 20 dB Bandwidth, Highest Channel (2480 MHz, 8DPSK Mode)

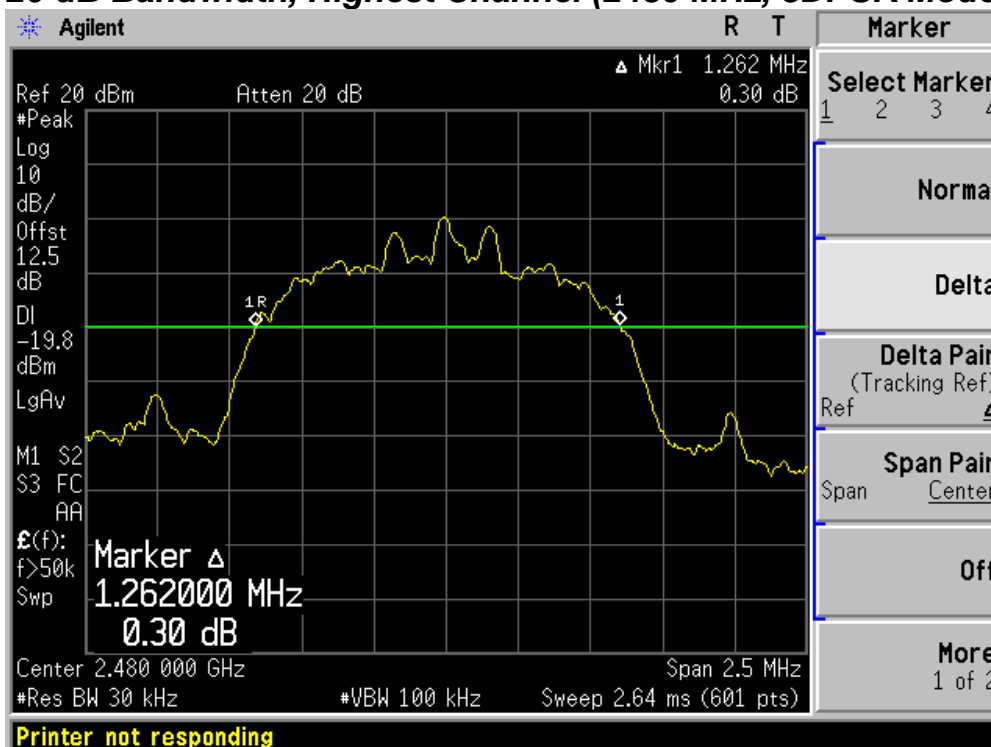

## TEST DATA

---

### 8.4 Carrier Frequency Separation

FCC §15.247(a), IC RSS-210 A8.1(b)

Test Mode : Set to Hopping mode

Result:

Modulation Mode	Carrier Frequency Separation (kHz)	Limit (2/3 of 20dB Bandwidth) (kHz)	Margin (kHz)
GFSK	1000.0	630.7	369.3
8DPSK	1020.0	844.7	175.3

## PLOTS OF EMISSIONS

### Carrier Frequency Separation (GFSK Mode)

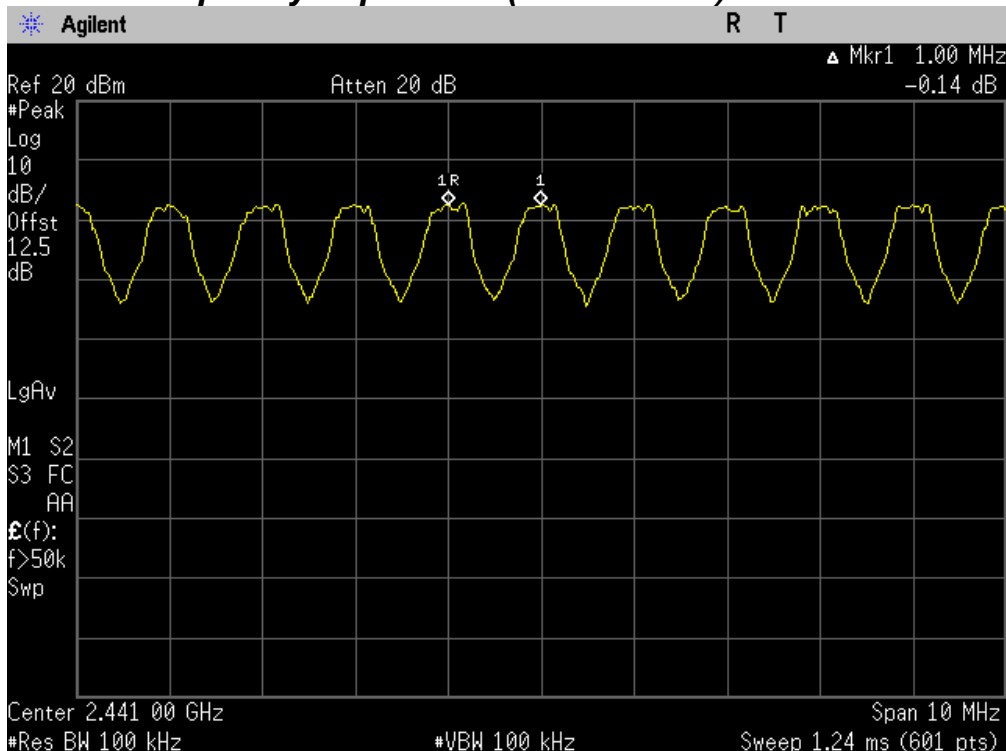

### Carrier Frequency Separation (8DPSK Mode)

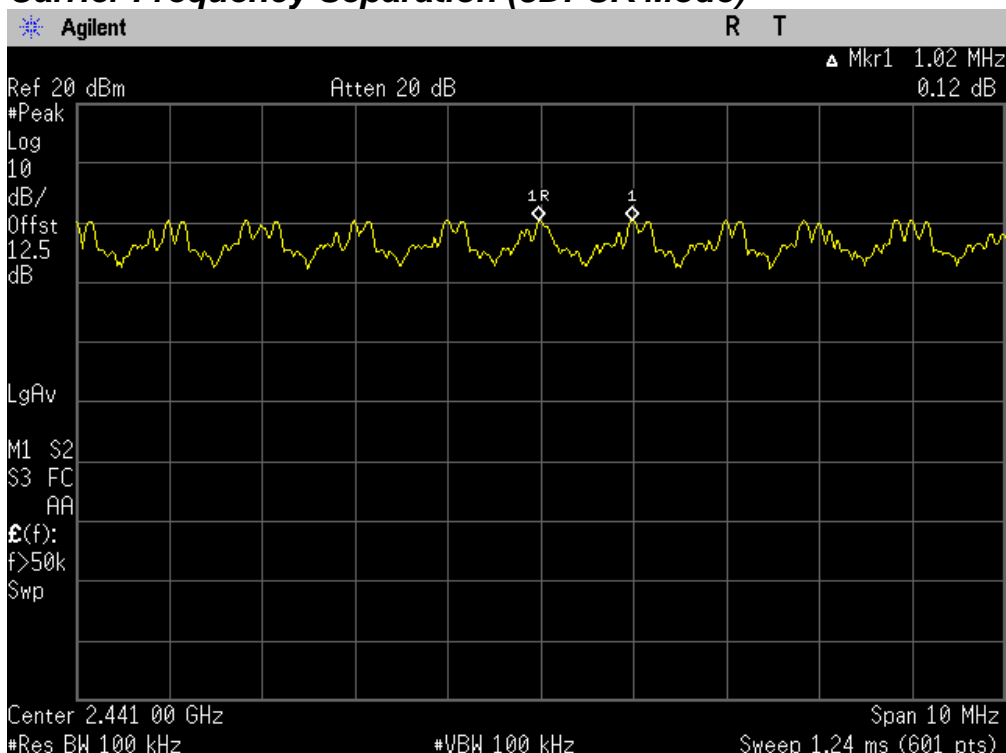

## TEST DATA

---

### 8.5 Transmitter Average Time of Occupancy

FCC §15.247(a), IC RSS-210 A8.1(d)

Test Mode : Set to Hopping mode

Result:

Modulation Mode	Pulse width ( $\mu$ s)	Number of 3.16 second	<sup>1)</sup> Average time of Occupancy(s)	Margin (s)
GFSK	2950	11	0.32450	0.07550
8DPSK	2958	11	0.32538	0.07462

Notes:

<sup>1)</sup> Average time of Occupancy = pulse width x Number of 3.16 sec x 10

# PLOT OF TEST DATA

## One pulse Width (GFSK Mode)

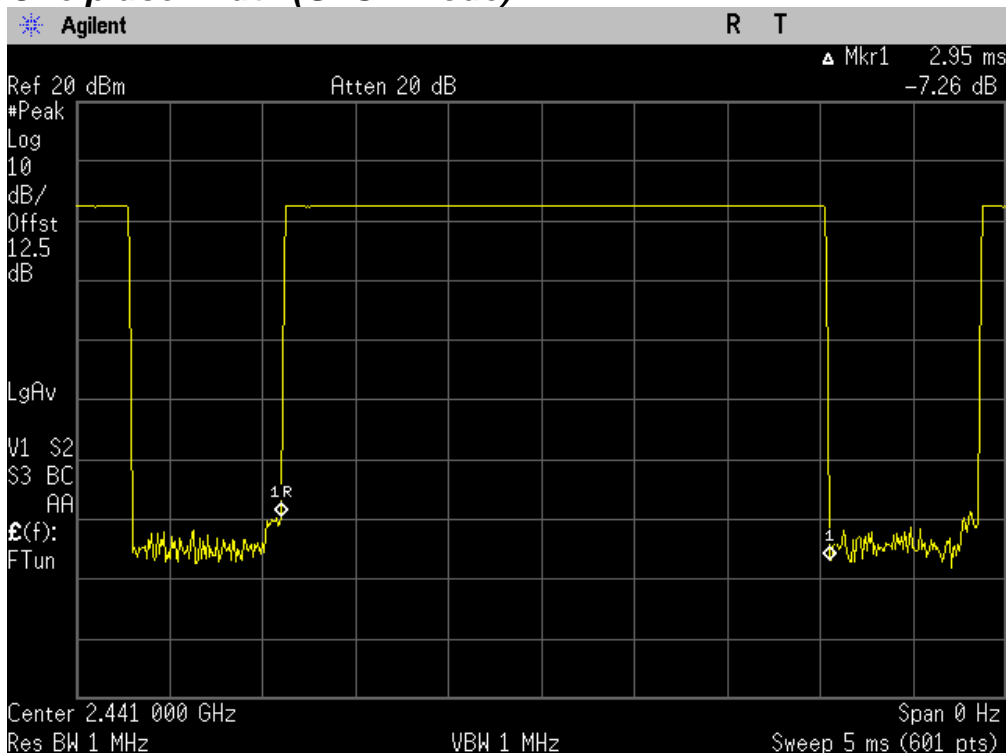

## Number of pulses in 3.16 second period (GFSK Mode)

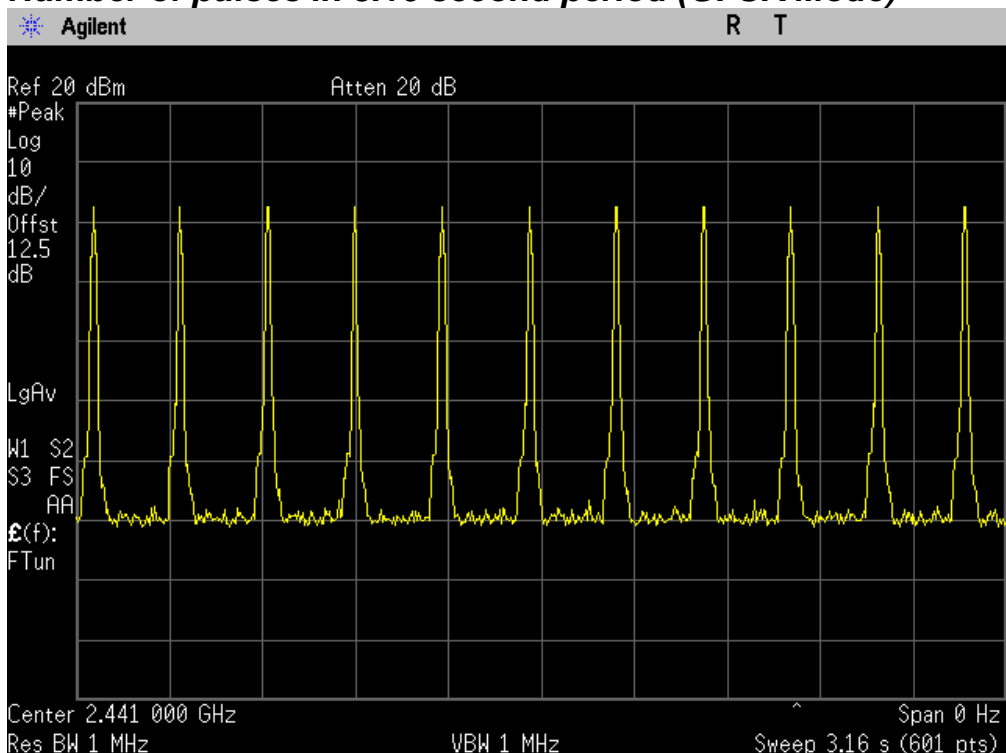

# PLOT OF TEST DATA

## One pulse Width (8DPSK Mode)

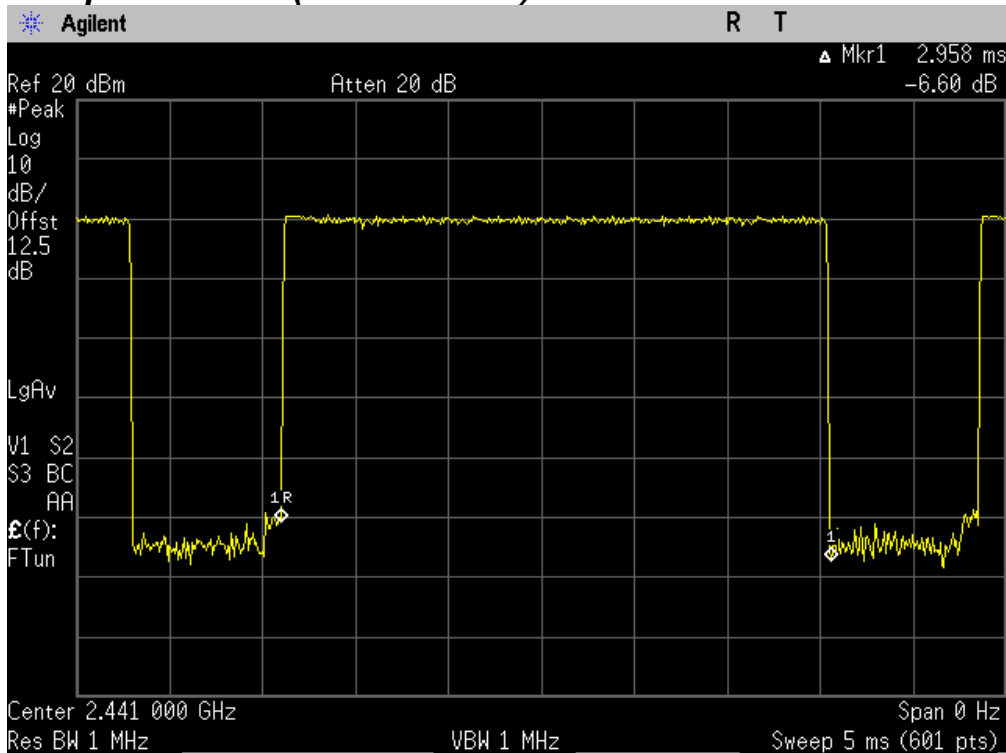

## Number of pulses in 3.16 second period (8DPSK Mode)

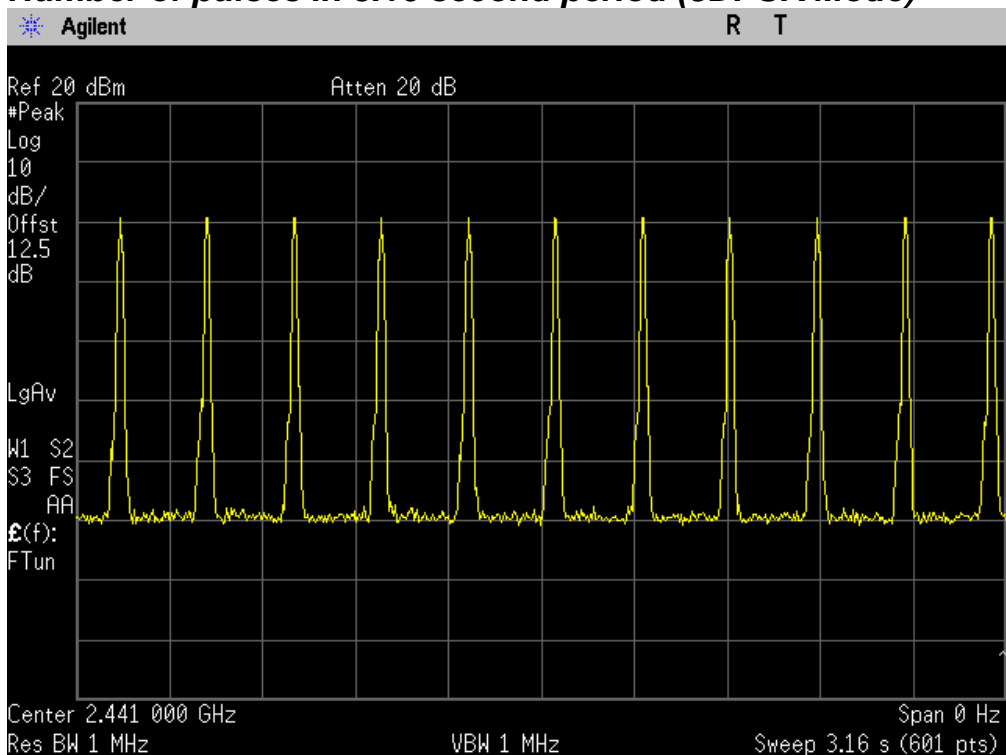

## **TEST DATA**

---

### **8.6 Number of Hopping Channels**

FCC §15.247(a), IC RSS-210 A8.1(d)

Test Mode : Set to Hopping mode

**Result:**

Total Hopping Channels = 40 + 39 = 79

The EUT meets the specifications of Section 15.247(a)(1)(iii) for Number of Hopping Channels.

## PLOT OF TEST DATA

### Top half of Authorized band

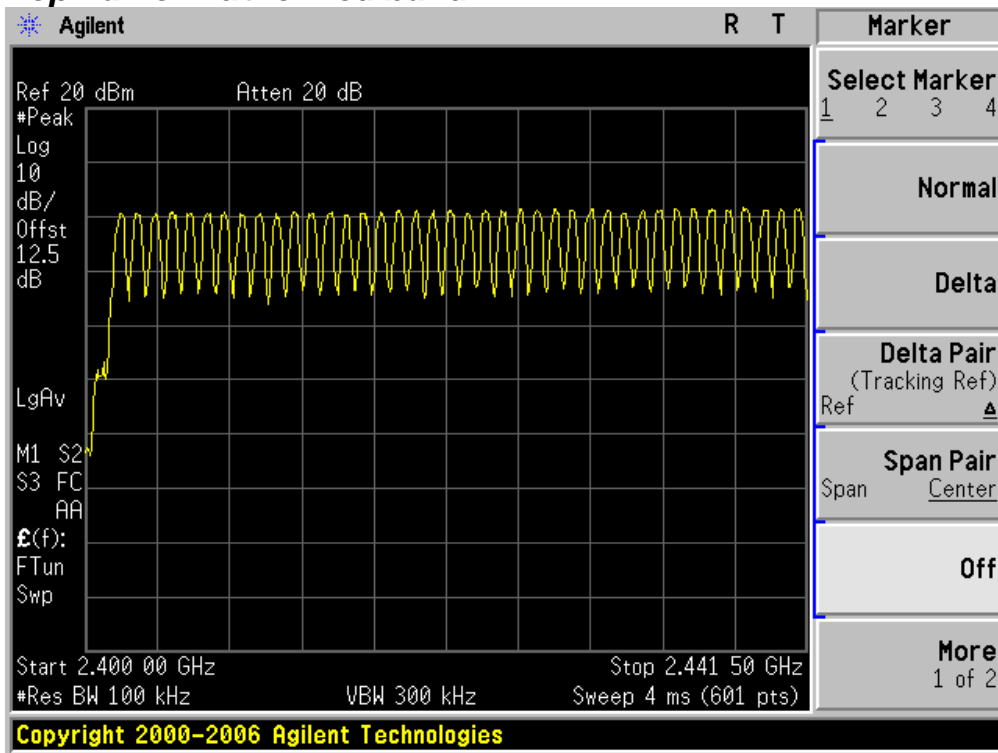

### Bottom half of Authorized band

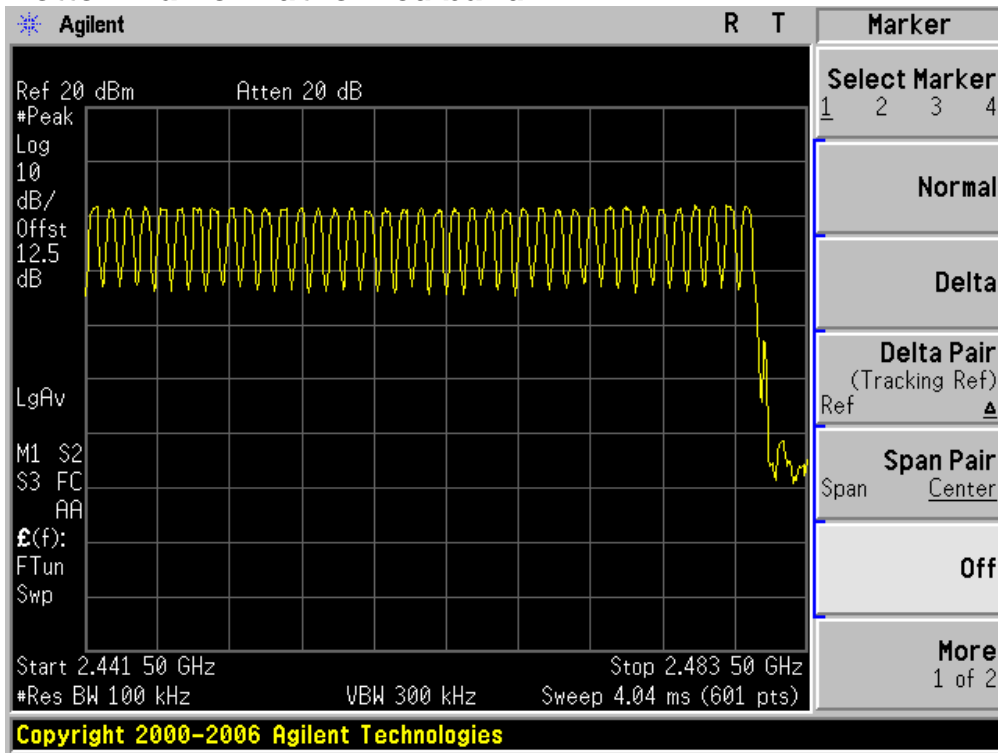

## TEST DATA

---

### 8.7 Peak Power Output

FCC §15.247(b), IC RSS-210 Issue 7 Clause A8.4

Test Mode : Set to Lowest channel, Middle channel and Highest channel

Result:

Modulation Mode	Frequency (MHz)	Conducted Power (dBm)	Antenna Gain (dBi)	EIRP (dBm)	EIRP (mW)
GFSK	2402	2.12	3.00	5.12	3.25
GFSK	2441	2.72	3.00	5.72	3.73
GFSK	2480	2.69	3.00	5.69	3.71
8DPSK	2402	0.96	3.00	3.96	2.49
8DPSK	2441	1.29	3.00	4.29	2.69
8DPSK	2480	1.10	3.00	4.10	2.57

## PLOT OF TEST DATA

### Output Power, Lowest Channel (2402 MHz, GFSK Mode)

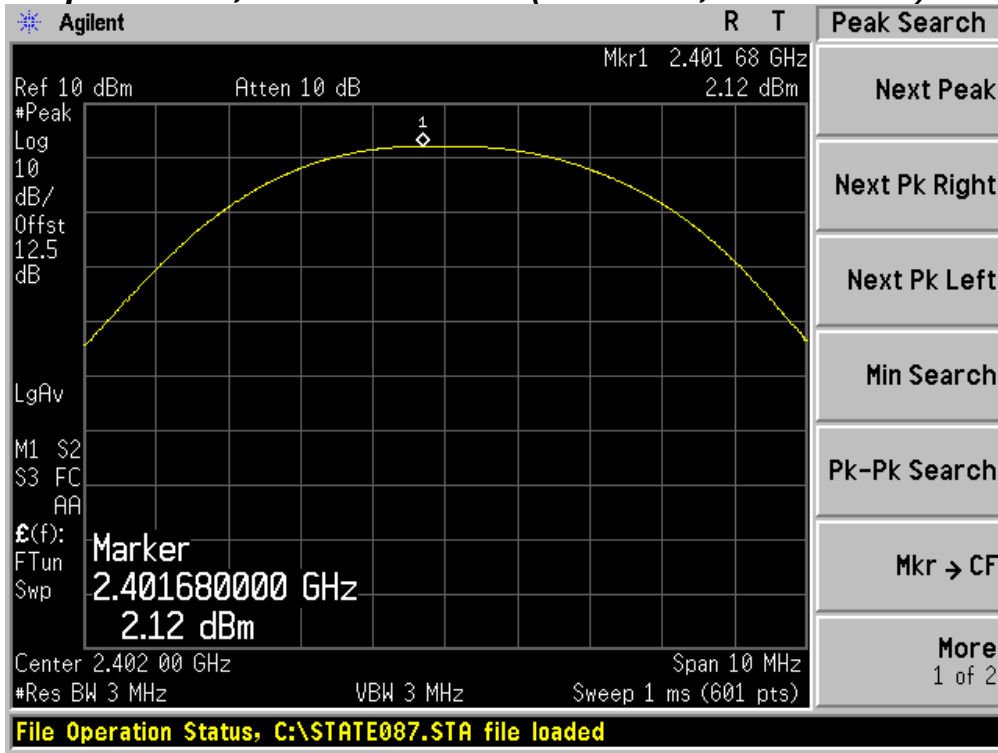

### Output Power, Lowest Channel (2402 MHz, 8DPSK Mode)

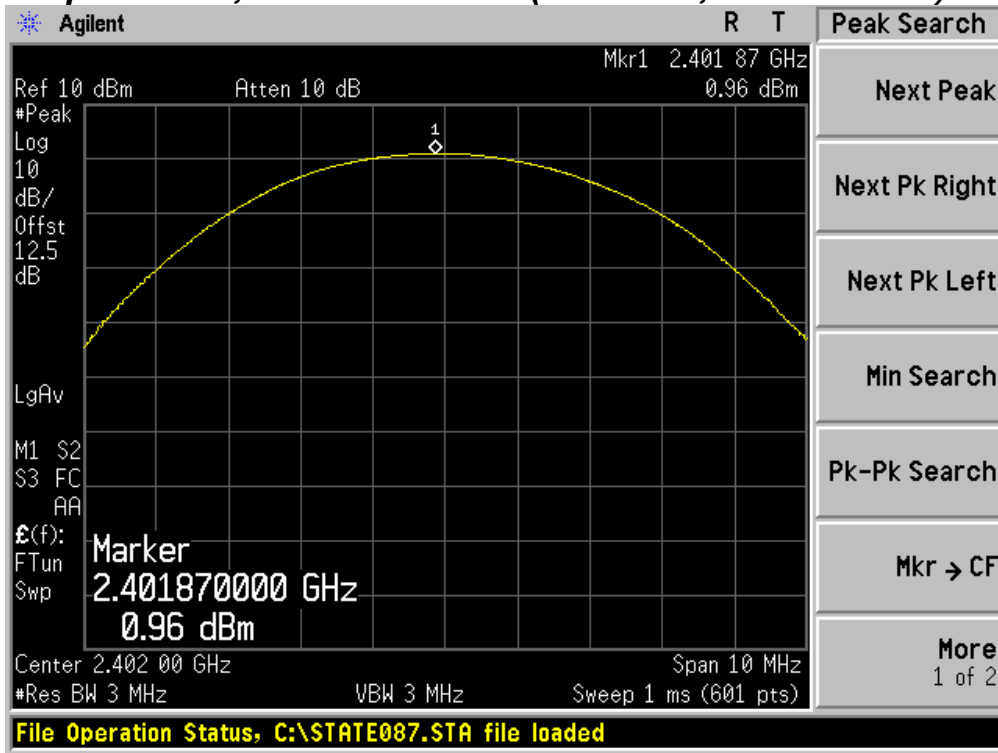

## PLOT OF TEST DATA

### Output Power, Middle Channel (2441 MHz, GFSK Mode)

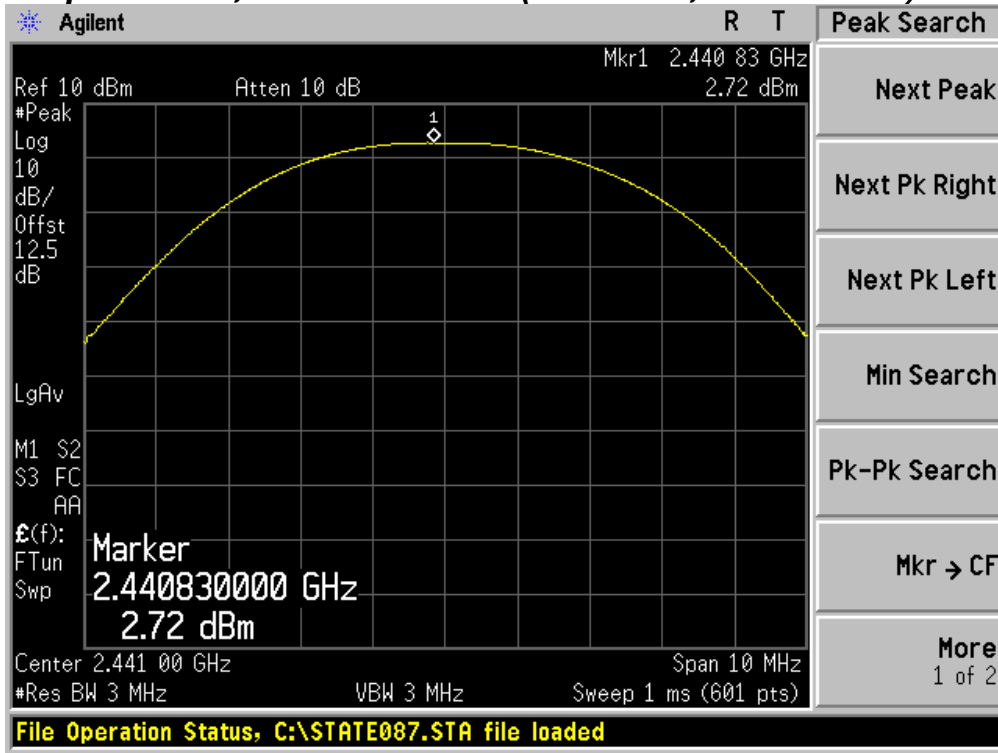

### Output Power, Middle Channel (2441 MHz, 8DPSK Mode)

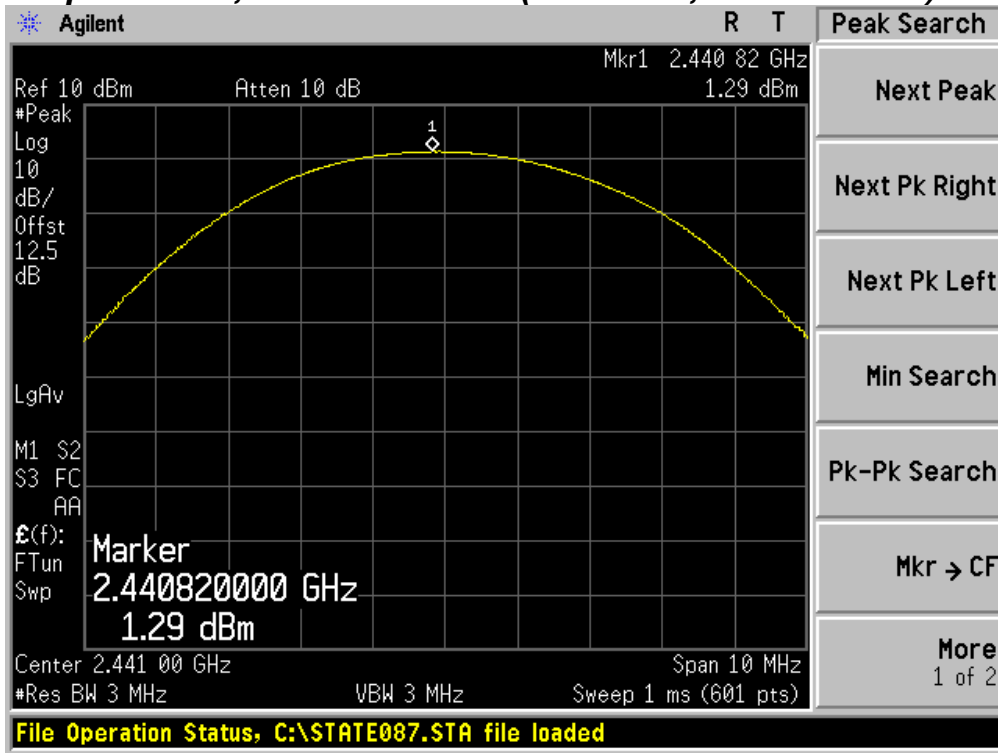

## PLOT OF TEST DATA

### Output Power, Highest Channel (2480 MHz, GFSK Mode)

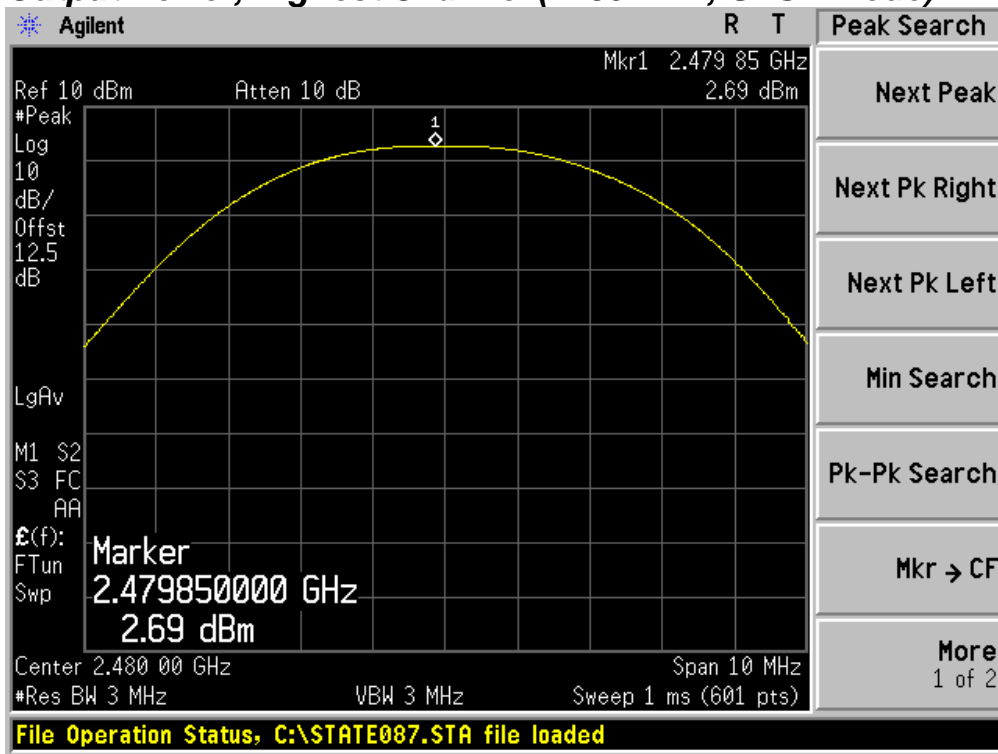

### Output Power, Highest Channel (2480 MHz, 8DPSK Mode)

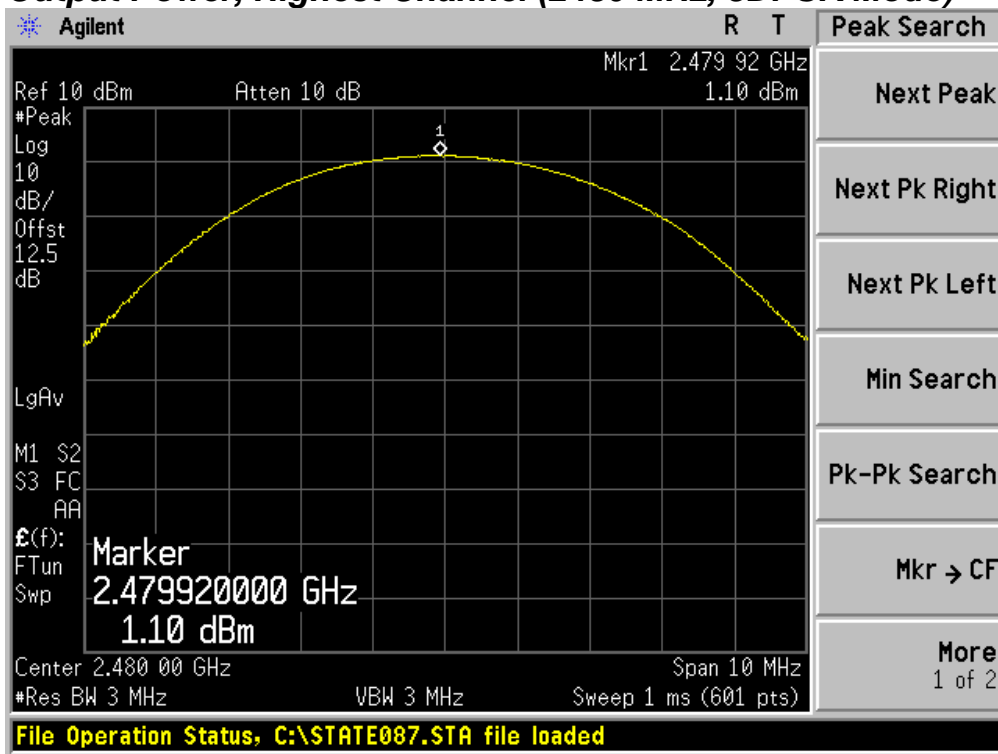

## TEST DATA

---

### 8.8 Conducted Spurious Emission

FCC §15.247(d), IC RSS-210 A8.5

Test Mode : Set to Lowest channel, Middle channel and Highest channel

Result:

Modulation Mode	Frequency(MHz)	Result(dBc)	Limit(dBc)
GFSK	2402	More than 30 dBc	20
GFSK	2441	More than 30 dBc	20
GFSK	2480	More than 30 dBc	20
8DPSK	2402	More than 30 dBc	20
8DPSK	2441	More than 30 dBc	20
8DPSK	2480	More than 30 dBc	20

## PLOT OF TEST DATA

### Conducted Spurious Emissions, 30 MHz ~ 2.9 GHz(2402 MHz, GFSK Mode)

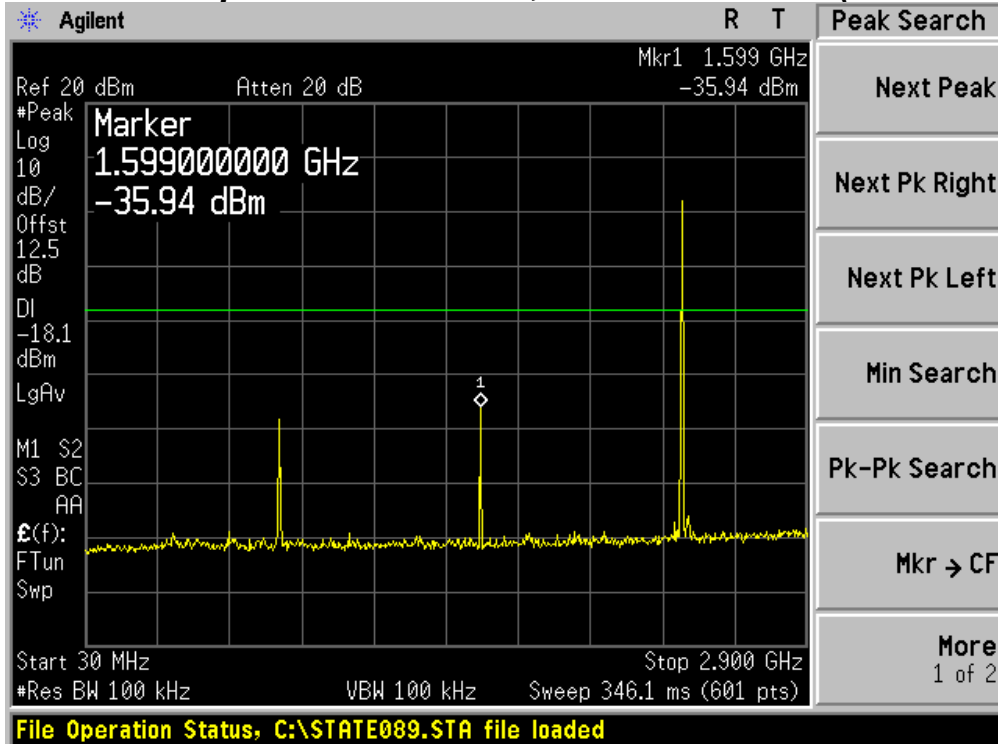

### Conducted Spurious Emissions, 2.9 GHz ~ 25 GHz(2402 MHz, GFSK Mode)

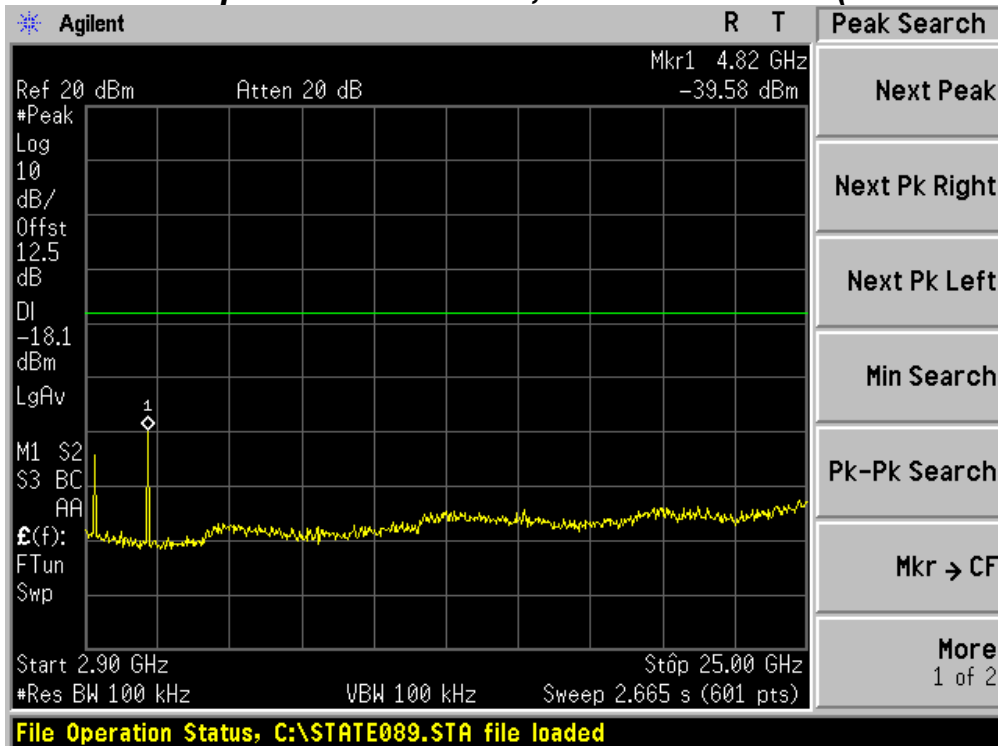

## PLOT OF TEST DATA

### Conducted Spurious Emissions, 30 MHz ~ 2.9 GHz(2402 MHz, 8DPSK Mode)

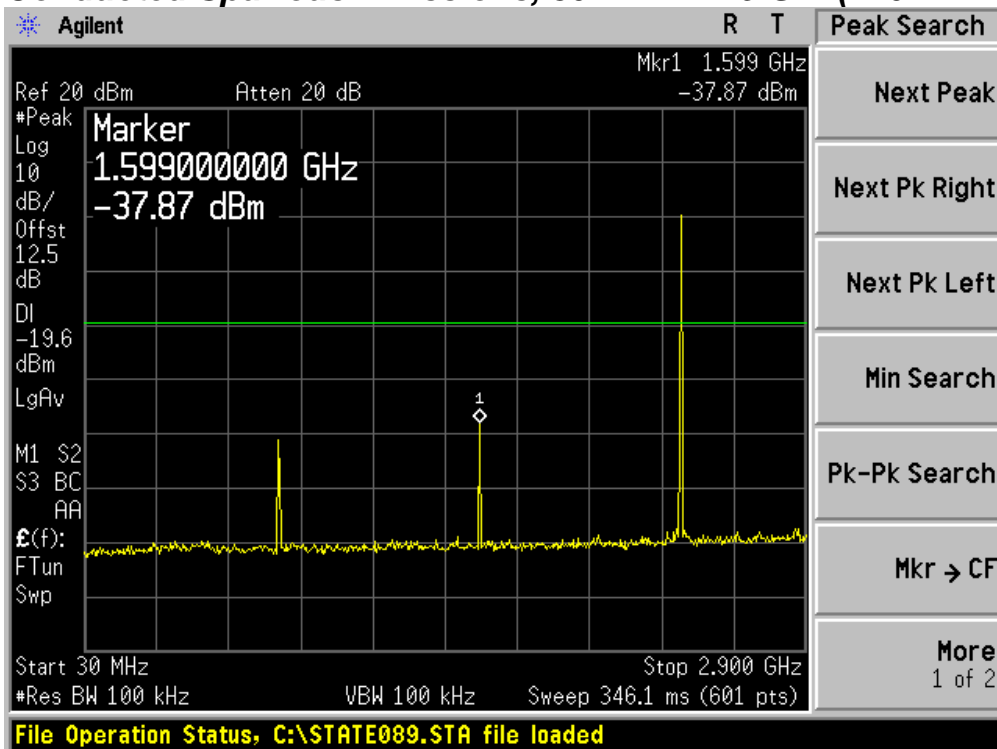

### Conducted Spurious Emissions, 2.9 GHz ~ 25 GHz(2402 MHz, 8DPSK Mode)

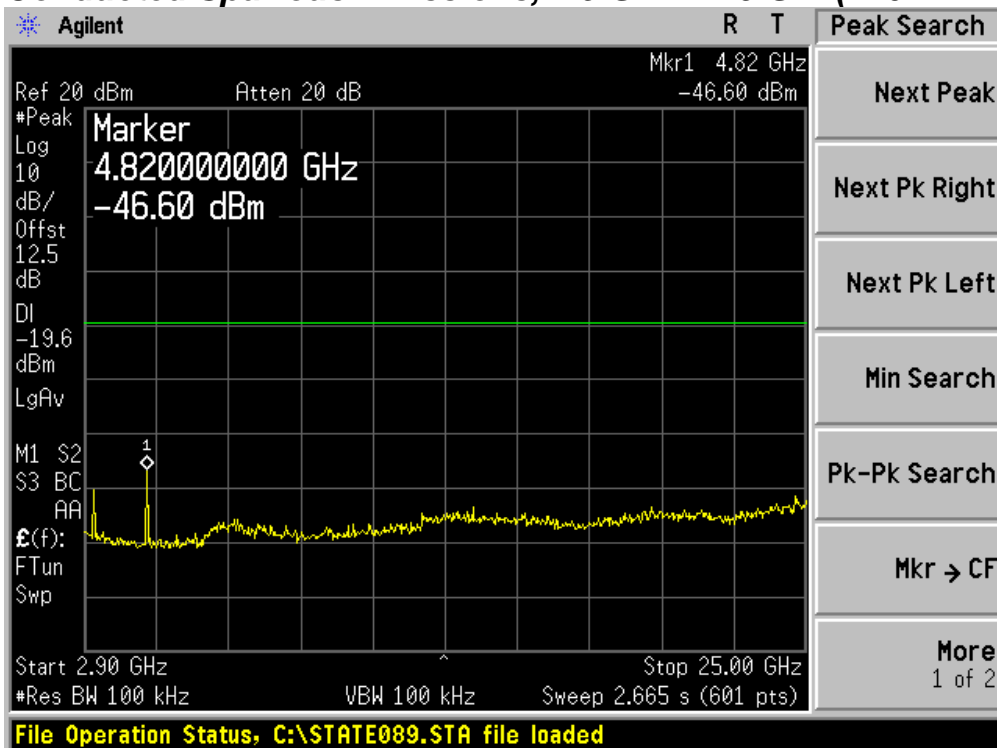

## PLOT OF TEST DATA

### Conducted Spurious Emissions, 30 MHz ~ 2.9 GHz(2441 MHz, GFSK Mode)

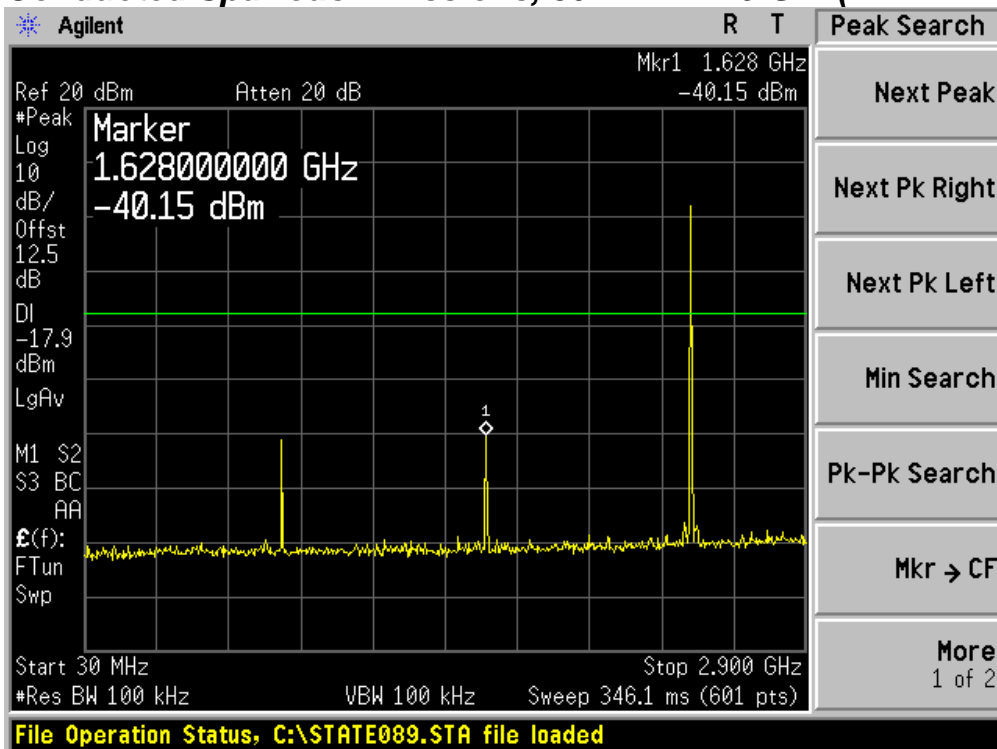

### Conducted Spurious Emissions, 2.9 GHz ~ 25 GHz(2441 MHz, GFSK Mode)

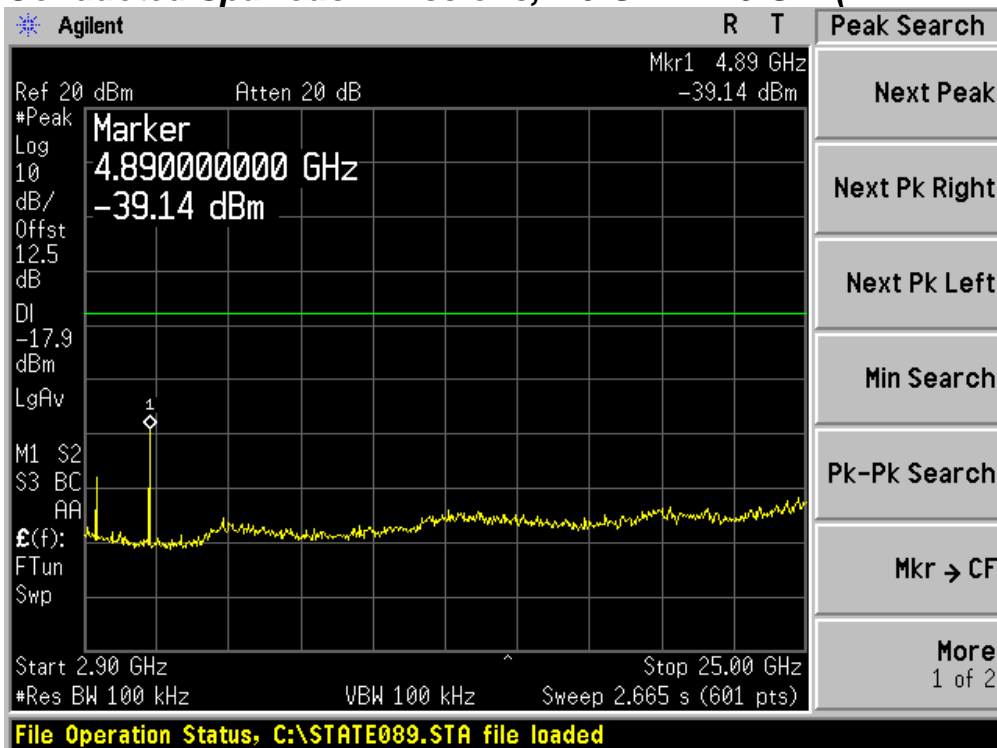

# PLOT OF TEST DATA

## Conducted Spurious Emissions, 30 MHz ~ 2.9 GHz(2441 MHz, 8DPSK Mode)

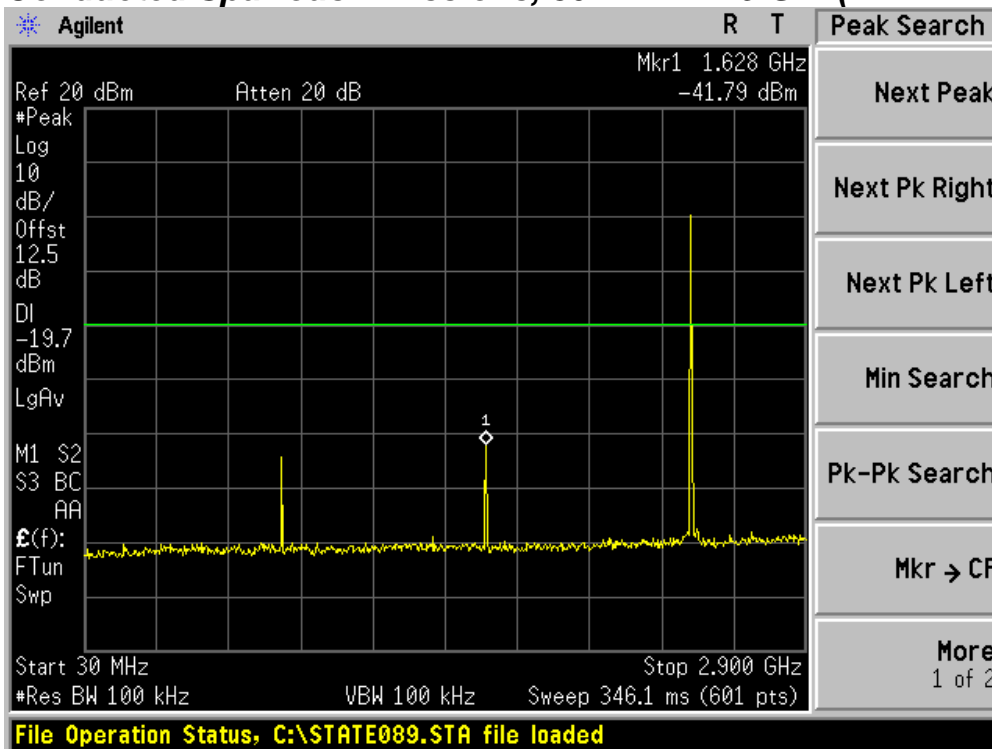

## Conducted Spurious Emissions, 2.9 GHz ~ 25 GHz(2441 MHz, 8DPSK Mode)

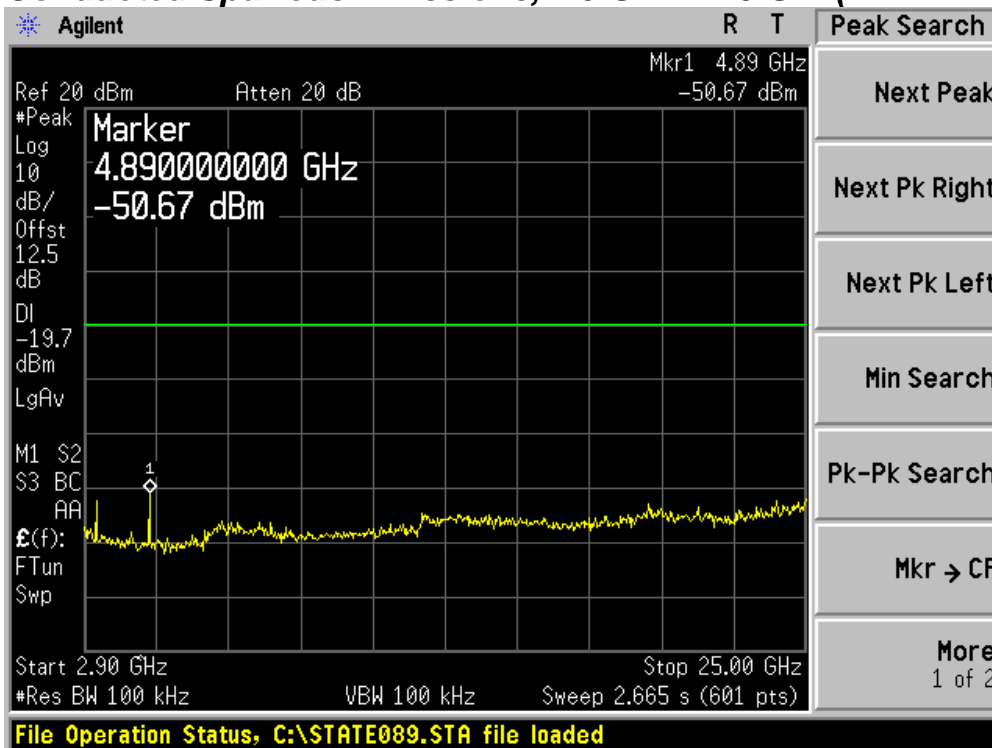

## PLOT OF TEST DATA

### Conducted Spurious Emissions, 30 MHz ~ 2.9 GHz(2480 MHz, GFSK Mode)

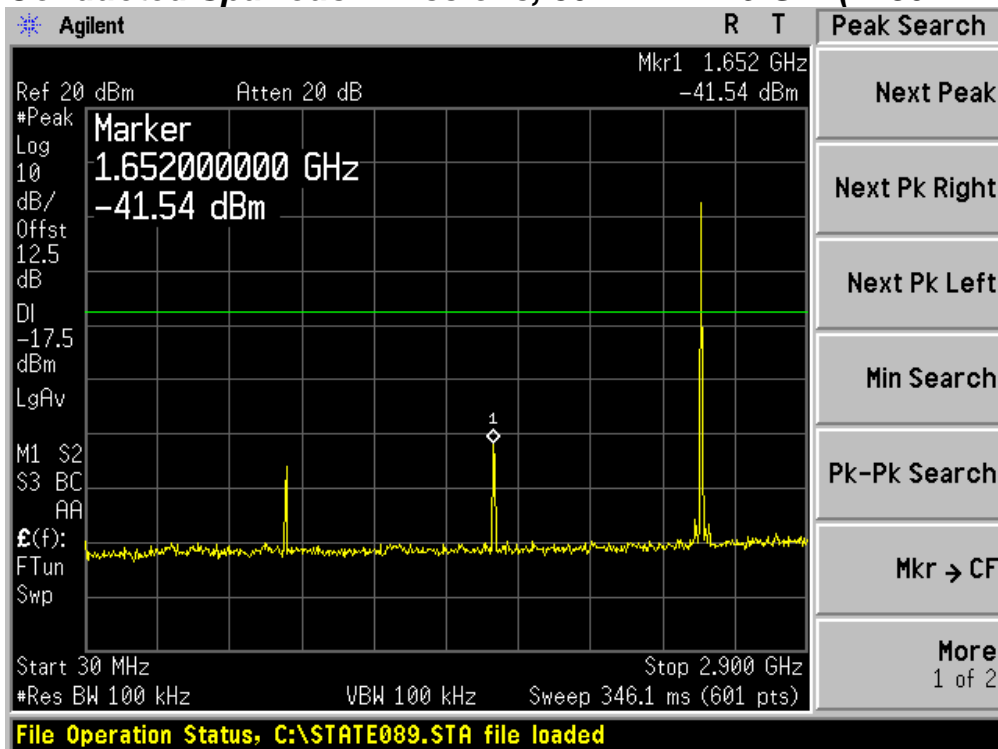

### Conducted Spurious Emissions, 2.9 GHz ~ 25 GHz(2480 MHz, GFSK Mode)

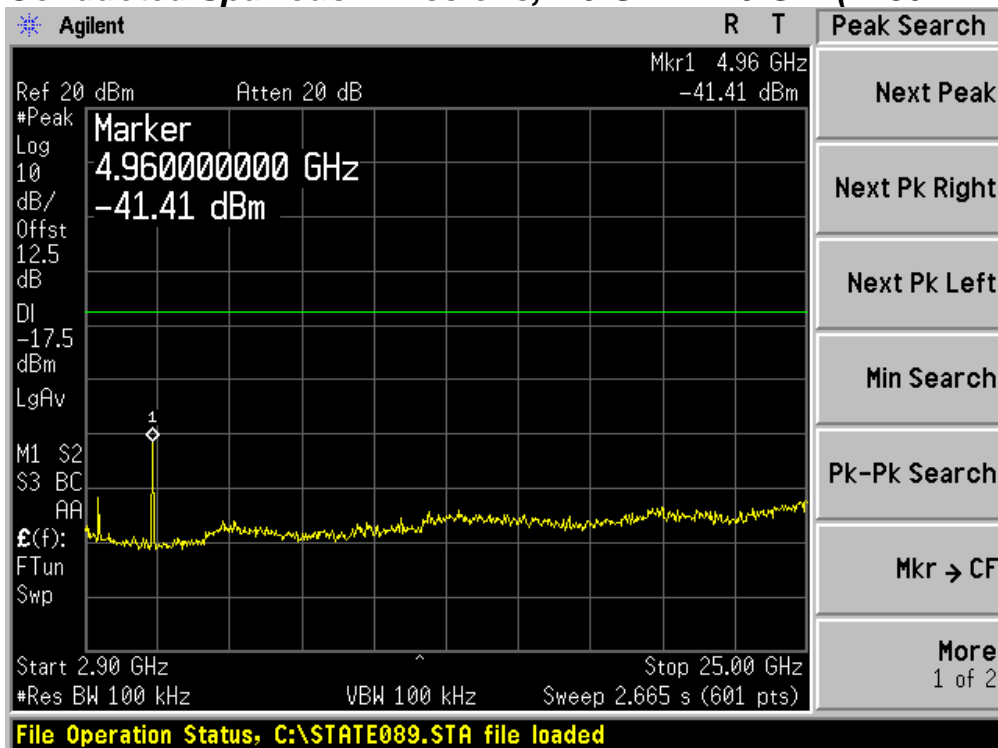

## PLOT OF TEST DATA

### Conducted Spurious Emissions, 30 MHz ~ 2.9 GHz(2480 MHz, 8DPSK Mode)

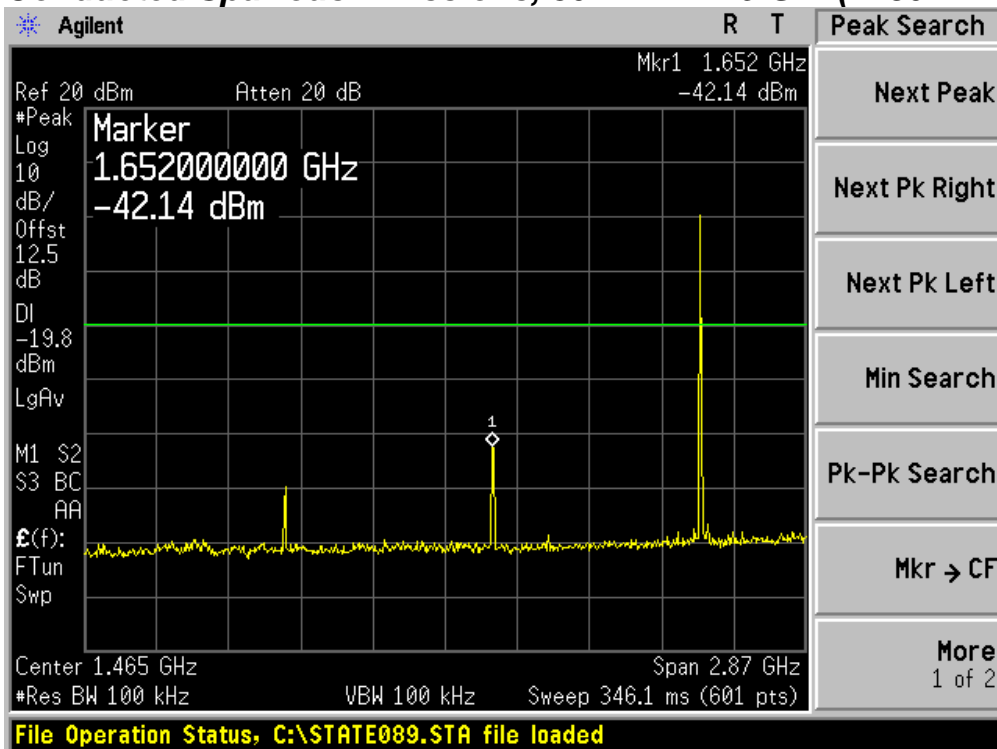

### Conducted Spurious Emissions, 2.9 GHz ~ 25 GHz(2480 MHz, 8DPSK Mode)

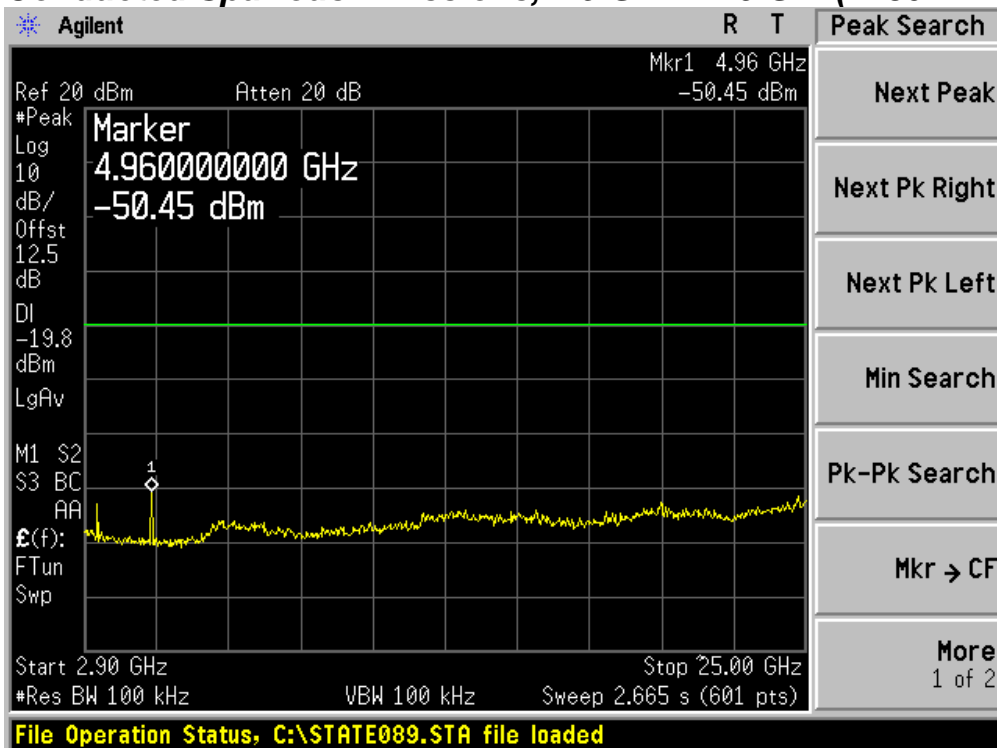

## PLOT OF TEST DATA

### Band Edge , Lowest Channel(2402 MHz, GFSK Mode)

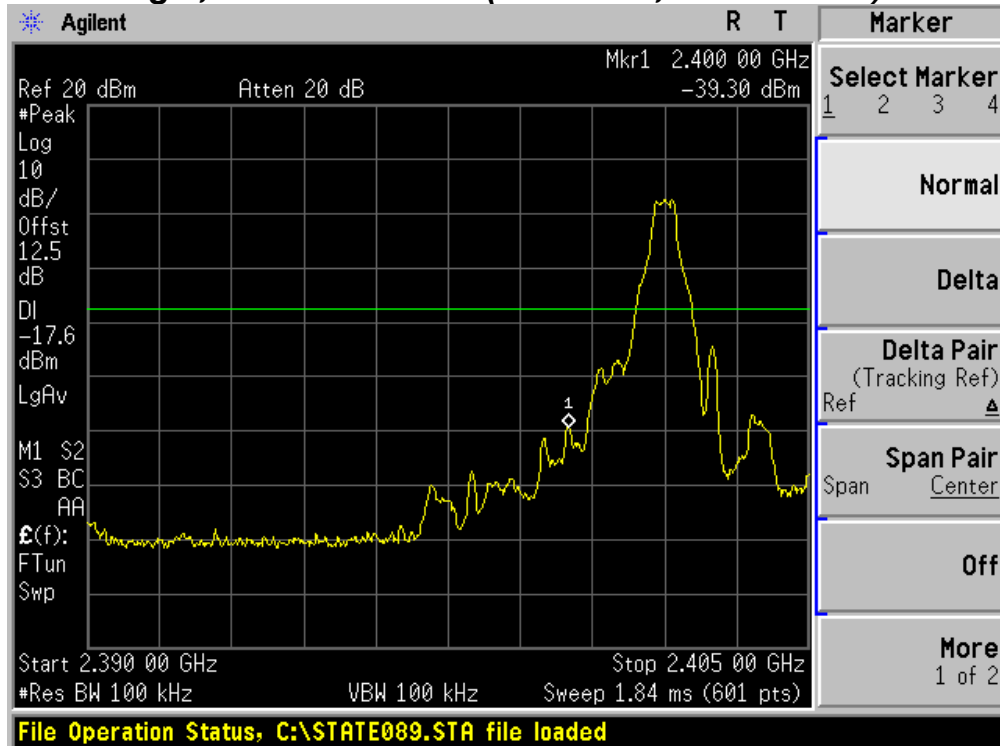

### Band Edge , Lowest Channel(2402 MHz, 8DPSK Mode)

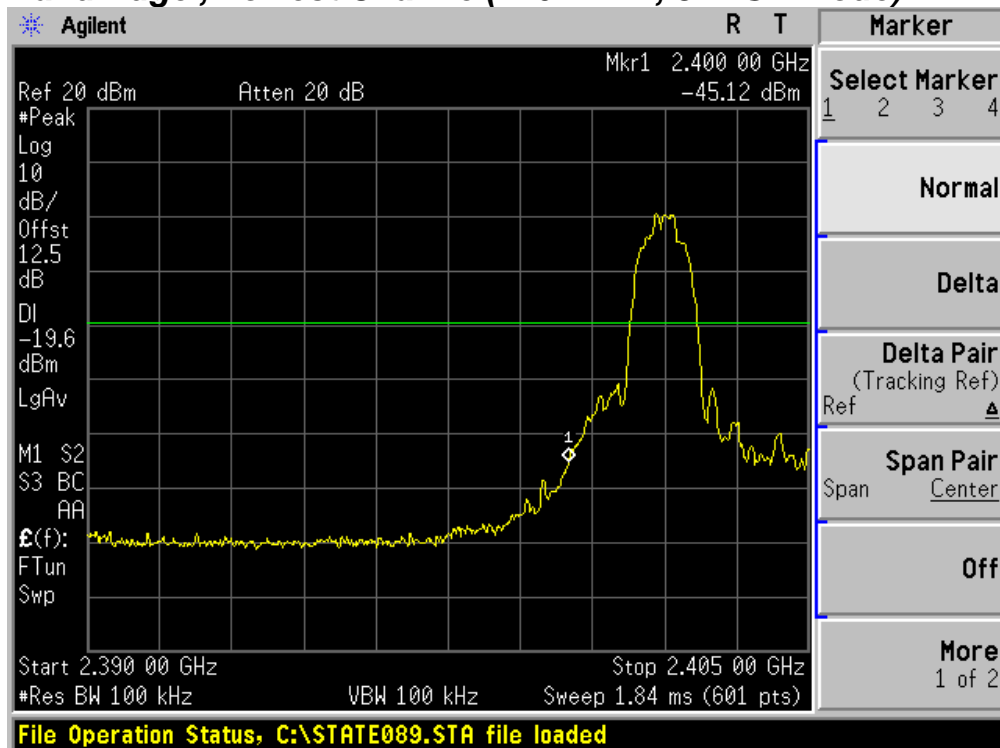

# PLOT OF TEST DATA

## Band Edge , Highest Channel(2480 MHz, GFSK Mode)

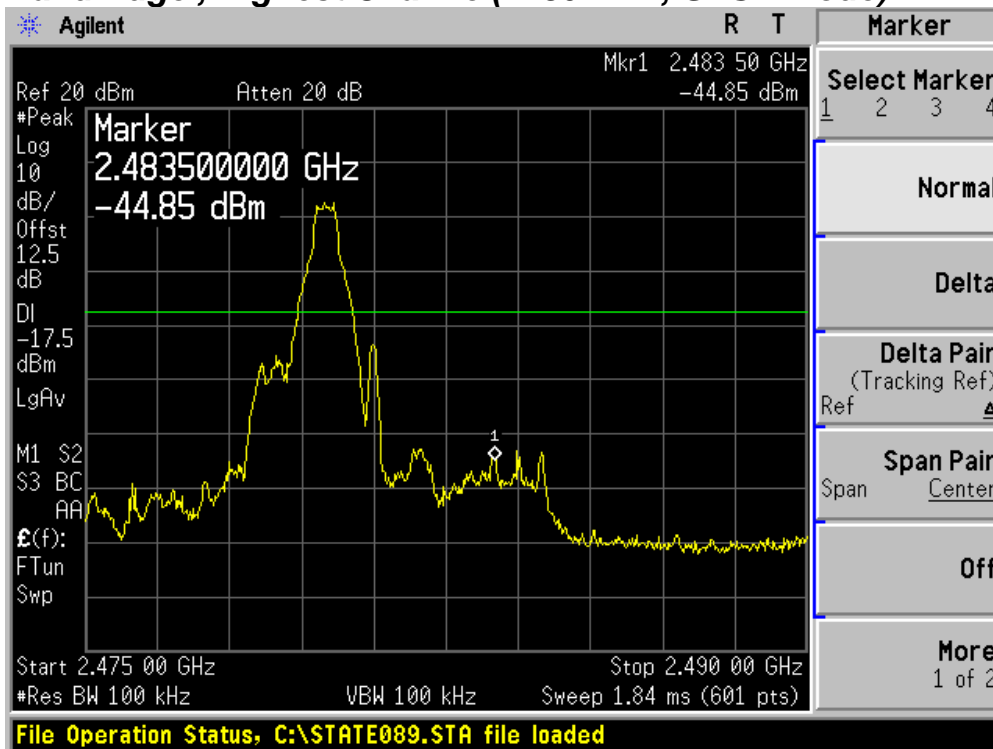

## Band Edge , Highest Channel(2480 MHz, 8DPSK Mode)

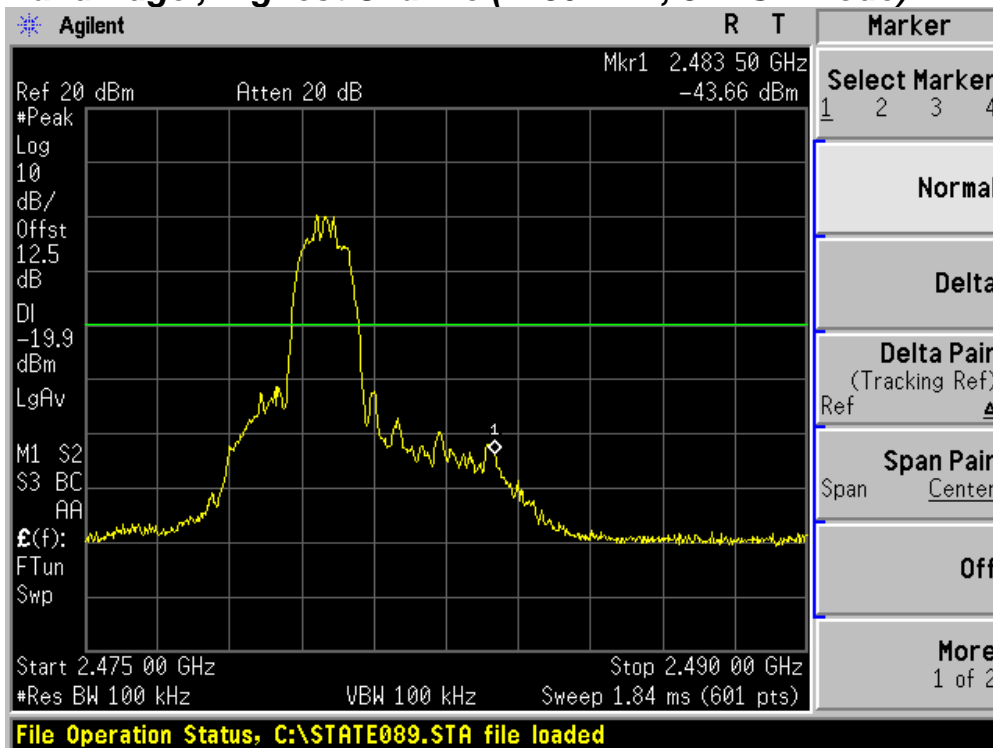

## TEST DATA

### 8.9 Radiated Spurious Emission

FCC §15.247(d), IC RSS-210 Clause 2.6, IC RSS-GEN Clause 6

Test Mode : Set to Lowest channel, Middle channel and Highest channel

Result:

#### Lowest Channel

Frequency (MHz)	Reading (dB $\mu$ V)	Pol* (H/V)	mode	AF+CL+Amp (dB)**	Result (dB $\mu$ V/m)	Limit (dB $\mu$ V/m)	Margin (dB)
1602	50.93	V	peak	-5.22	43.16	74.0	28.29
1602	47.12	V	average	-5.22	40.62	54.0	12.10
1602	51.29	H	peak	-5.22	46.40	74.0	27.93
1602	49.97	H	average	-5.22	43.87	54.0	9.25
4804	43.29	V	peak	3.98	50.08	74.0	26.73
4804	38.56	V	average	3.98	42.66	54.0	11.46
4804	43.22	H	peak	3.98	48.63	74.0	26.80
4804	35.81	H	average	3.98	42.60	54.0	14.21

#### Middle Channel

Frequency (MHz)	Reading (dB $\mu$ V)	Pol* (H/V)	mode	AF+CL+Amp (dB)**	Result (dB $\mu$ V/m)	Limit (dB $\mu$ V/m)	Margin (dB)
1628	53.11	V	peak	-5.15	47.96	74.0	26.04
1628	51.99	V	average	-5.15	46.84	54.0	7.16
1628	50.57	H	peak	-5.15	45.42	74.0	28.58
1628	49.88	H	average	-5.15	44.73	54.0	9.27
4885	43.37	V	peak	4.49	47.86	74.0	26.14
4885	37.13	V	average	4.49	41.62	54.0	12.38
4885	41.00	H	peak	4.49	45.49	74.0	28.51
4885	33.88	H	average	4.49	38.37	54.0	15.63

## TEST DATA

### Highest Channel

Frequency (MHz)	Reading (dB $\mu$ V)	Pol* (H/V)	mode	AF+CL+Amp (dB)**	Result (dB $\mu$ V /m)	Limit (dB $\mu$ V /m)	Margin (dB)
1654	53.41	V	peak	-5.07	48.34	74.0	25.66
1654	52.45	V	average	-5.07	47.38	54.0	6.62
1654	52.80	H	peak	-5.07	47.73	74.0	26.27
1654	51.26	H	average	-5.07	46.19	54.0	7.81
4960	41.70	V	peak	4.95	46.65	74.0	27.35
4960	35.88	V	average	4.95	40.83	54.0	13.17
4960	41.19	H	peak	4.95	46.14	74.0	27.86
4960	34.42	H	average	4.95	39.37	54.0	14.63

1. \*Pol. H=Horizontal V=Vertical

2. \*\*AF+CL+Amp. = Antenna Factor + Cable Loss + Amplifier.

3. Other spurious are under 20 dB below Fundamental.

4. GFSK modulation mode is the worst condition.

5. The spectrum is measured from 9 kHz to 10<sup>th</sup> harmonic and the worst-case emissions are reported.

No significant emissions were found beyond the fifth harmonic for this device.

# PLOT OF TEST DATA

## Restricted Band Spurious Emissions, Lowest channel(Horizontal, Peak)

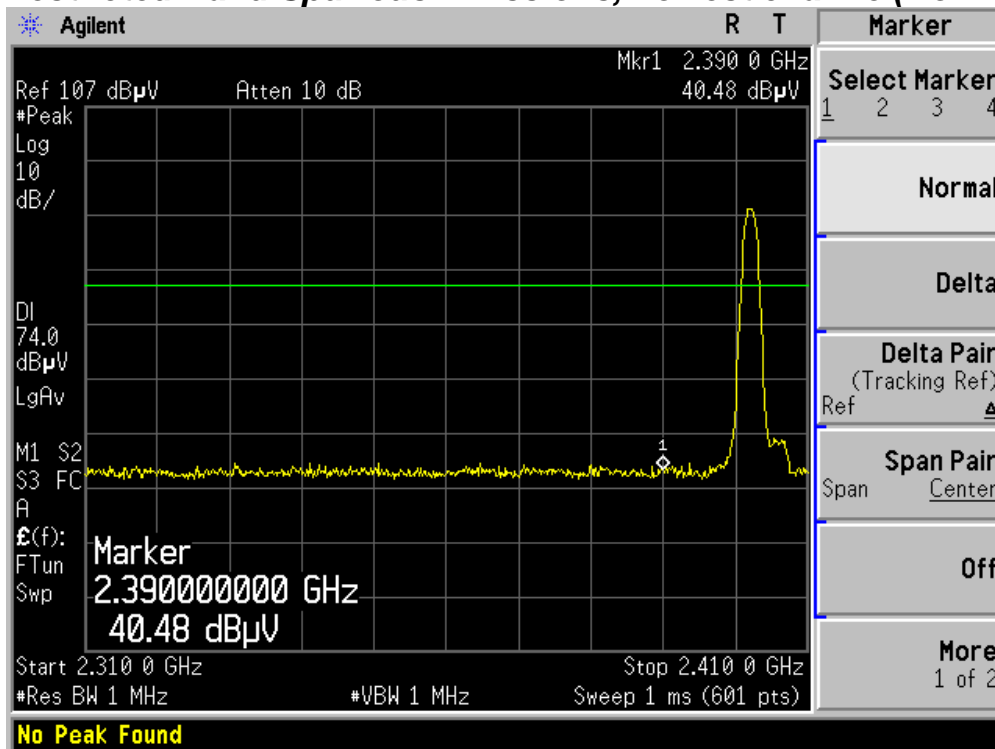

## Restricted Band Spurious Emissions, Lowest channel(Horizontal, Average)

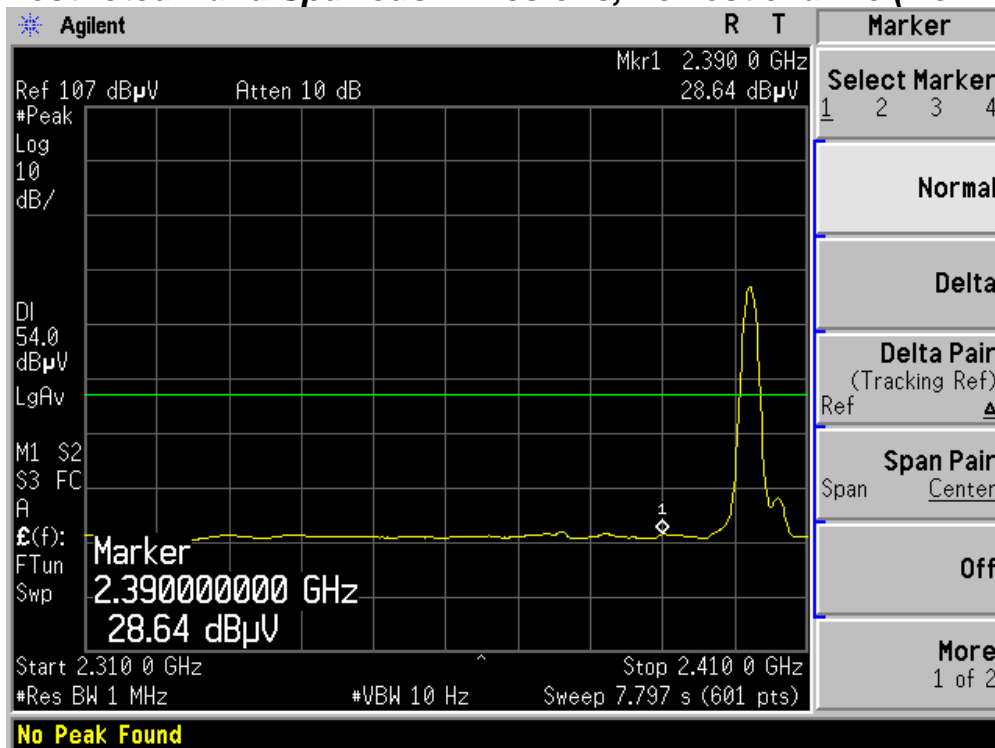

## PLOT OF TEST DATA

### Restricted Band Spurious Emissions, Lowest channel(Vertical, Peak)

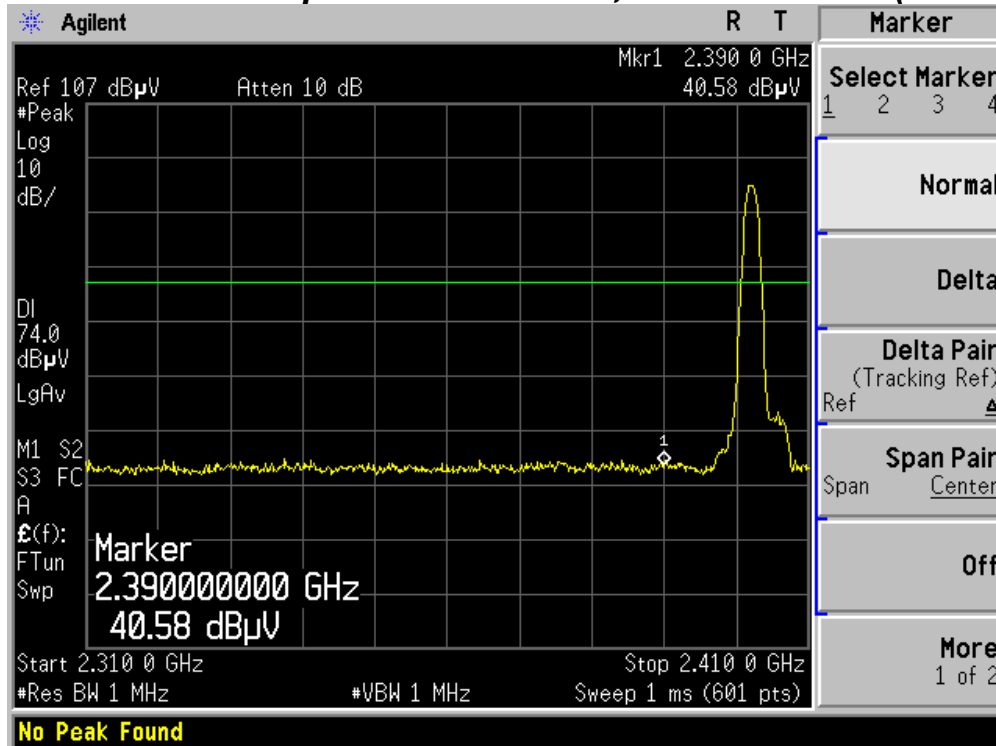

### Restricted Band Spurious Emissions, Lowest channel(Vertical, Average)

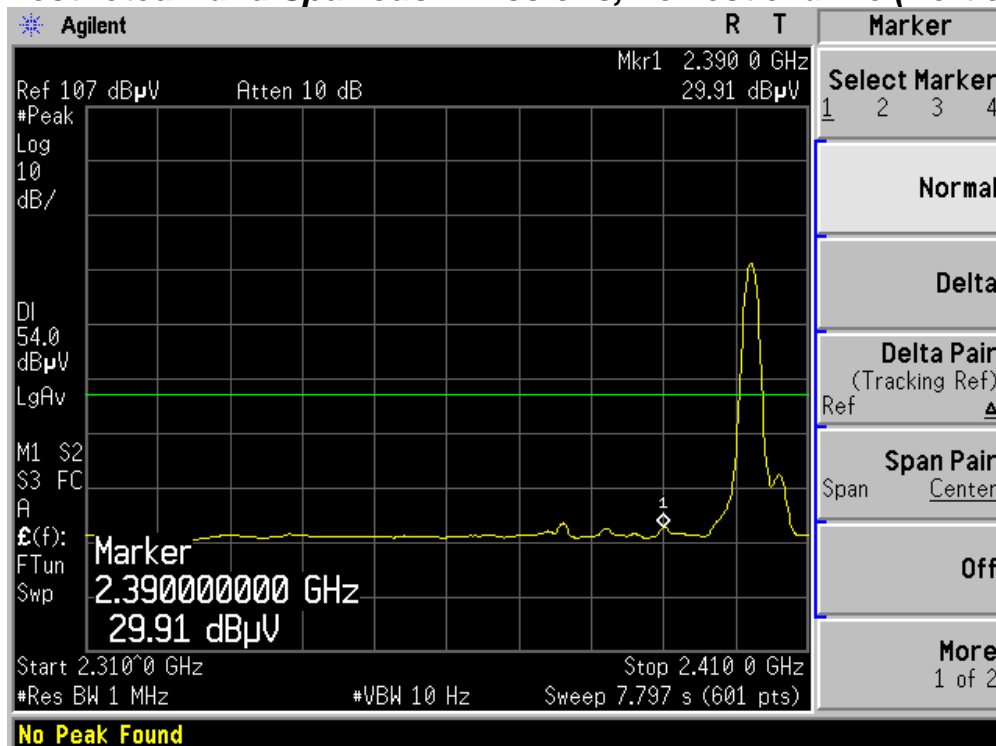

# PLOT OF TEST DATA

## Restricted Band Spurious Emissions, Highest channel(Horizontal, Peak)

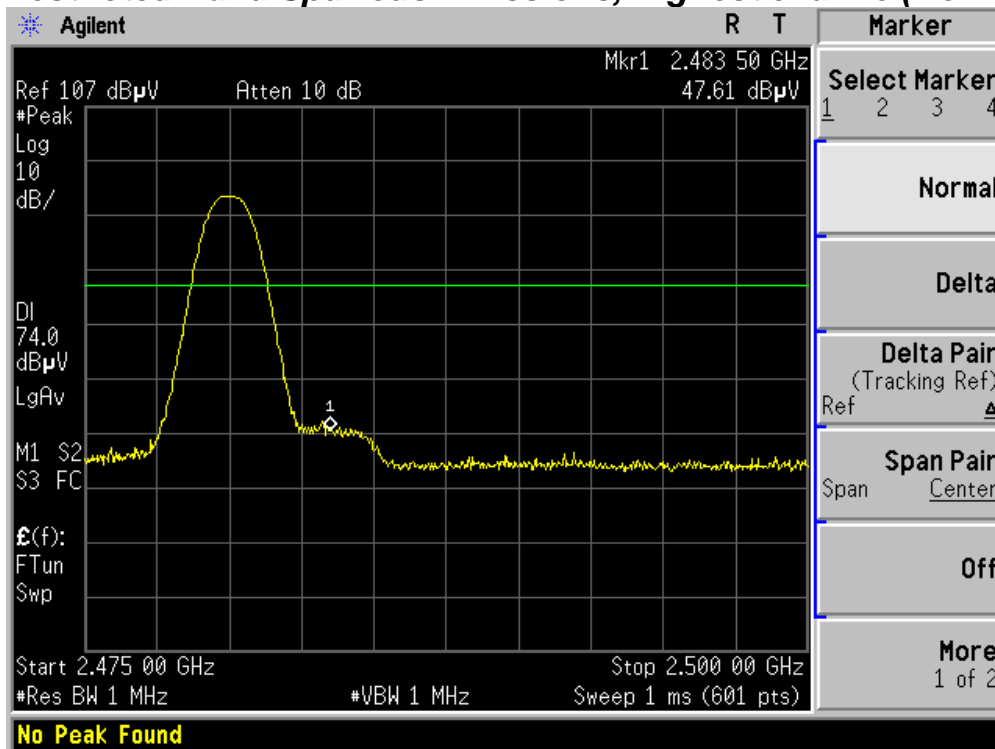

## Restricted Band Spurious Emissions, Highest channel(Horizontal, Average)

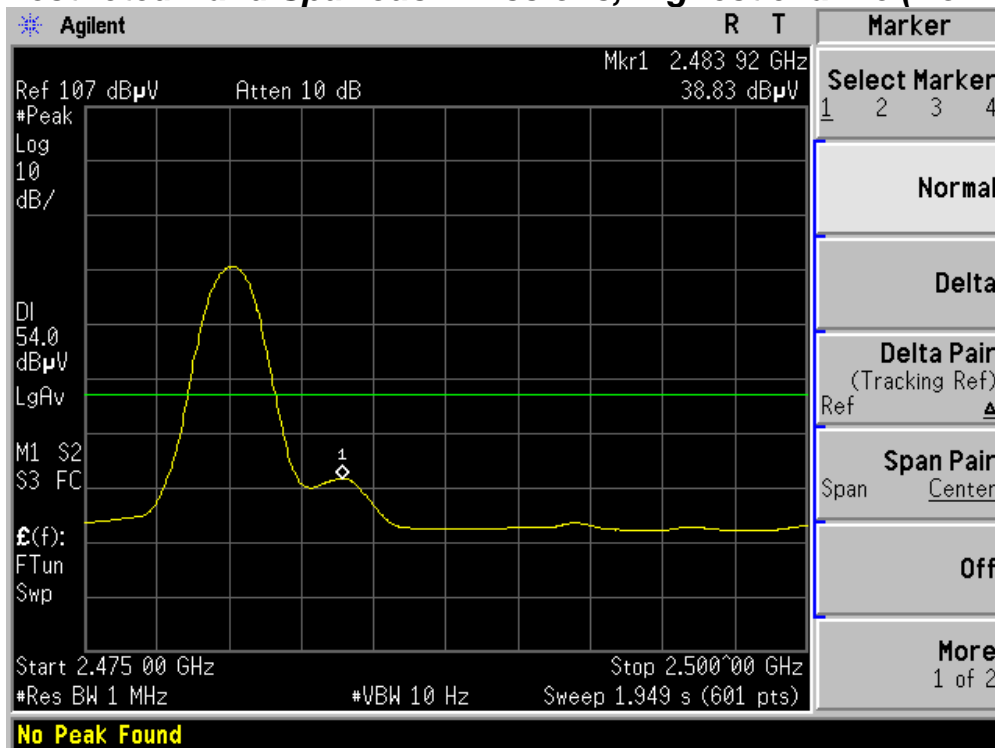

# PLOT OF TEST DATA

## Restricted Band Spurious Emissions, Highest channel(Vertical, Peak)

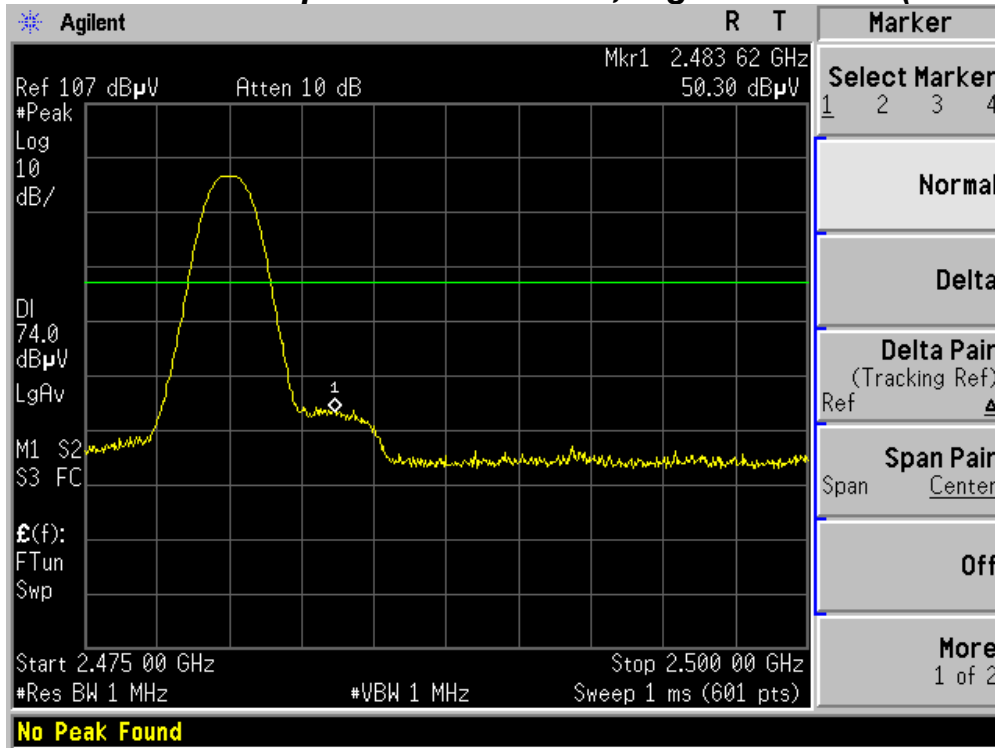

## Restricted Band Spurious Emissions, Highest channel(Vertical, Average)

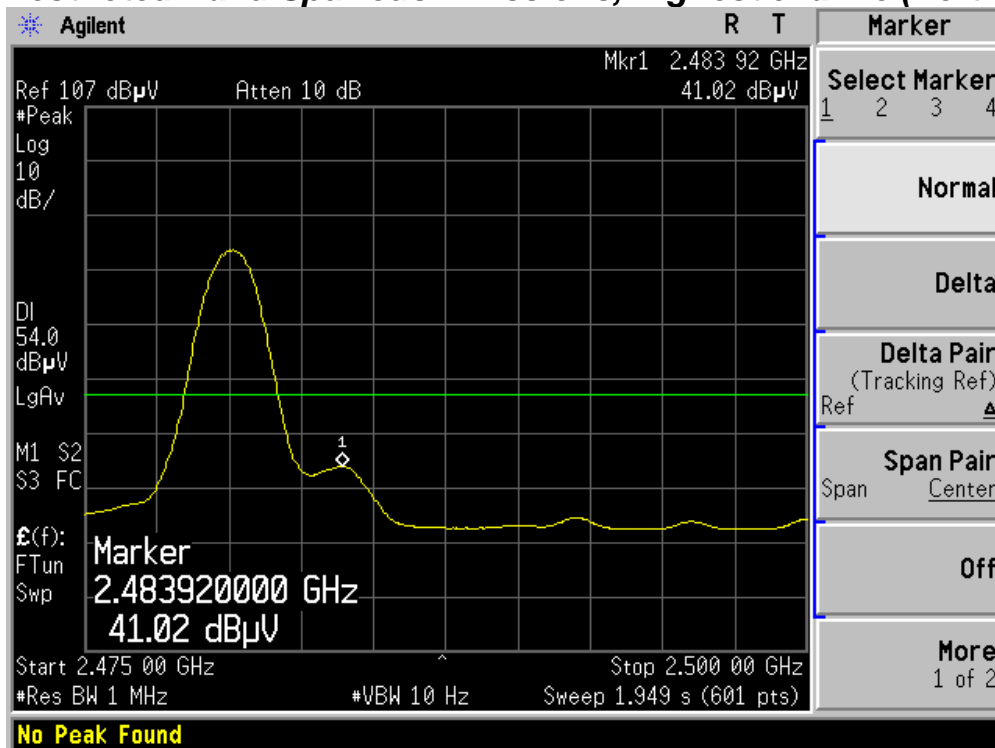

# TEST DATA

## 8.10 Receiver Spurious Emissions

### IC RSS-GEN Clause 6

Frequency (MHz)	Reading (dB $\mu$ V/m)	Pol* (H/V)	AF+CL+Amp (dB)**	Result (dB $\mu$ V/m)	Limit (dB $\mu$ V/m)	Margin (dB)
90.45	56.1	H	-20.7	35.4	43.5	8.1
136.63	51.2	V	-17.1	34.1	43.5	9.4
222.35	55.0	V	-19.1	35.9	46.0	10.1
228.29	55.1	V	-19.1	36.0	46.0	10.0
960.14	37.6	H	-1.3	36.3	46.0	9.7
1652.00	54.6	H	-5.07	49.5	54.0	4.5

Radiated Measurements at 3meters

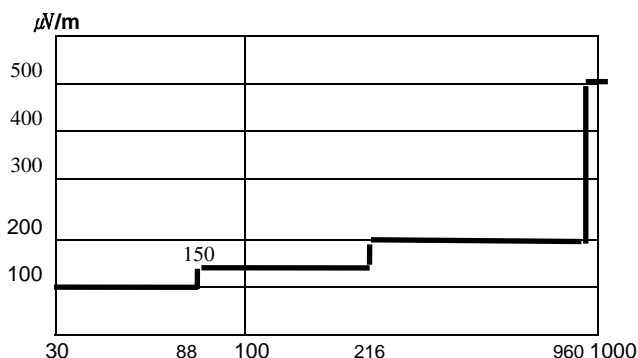

Fig. 6. Limits at 3 meters

**NOTES:**

1. All modes were measured and the worst-case emission was reported.
- 2 The radiated limits are shown on Figure 6.

Above 1GHz the limit is 500  $\mu$ V/m.

**NOTES:**

1. \*Pol. H=Horizontal, V=Vertical
2. \*\*AF+CL+Amp. = Antenna Factor + Cable Loss + Amplifier.
3. Measurements using CISPR quasi-peak mode.
4. The limit is on the IC RSS GEN Clause 6.
5. GFSK modulation mode is the worst condition.

## 9. MAXIMUM PERMISSIBLE EXPOSURE

### RF Exposure Limit

According to FCC 1.1310: The criteria listed in the following table shall be used to evaluate the Environmental of human exposure to radio frequency (RF) radiation as specified in 1.1307(b)

Limits for Maximum Permissible Exposure (MPE)

Frequency Range(MHz)	Electric Field Strength(V/m)	Magnetic Field Strength(A/m)	Power Density (mW/cm <sup>2</sup> )	Averaging Time (Minutes)
<b>(A) Limits for occupational / Control Exposure</b>				
30 - 300	61.4	0.163	1	6
300 - 1500	...	...	F/300	6
1500 - 100000	...	...	5	6
<b>(B) Limits for General Population / Uncontrolled Exposure</b>				
30 - 300	27.5	0.073	0.2	30
300 - 1500	...	...	F/1500	30
1500 - 100000	...	...	1	30

F = Frequency (MHz)

### Fries formula

Fries transmission formula :  $Pd = (Pout * G) / (4 * \pi * r^2)$

$$r = \sqrt{((Pout * G) / 4 * \pi * Pd)}$$

Where

Pd = Power density in mW/cm<sup>2</sup>

Pout = Output power to antenna in mW

G = Gain of antenna in linear scale

$\pi = 3.1416$

r = Distance between observation point center of the radiator in cm

Pd is the limit of MPE, 1 mW/cm<sup>2</sup>. If we know the Maximum Gain of the antenna and the total power input to the antenna, through the calculation, we will know the Maximum distance r where the MPE limit is reached and Power density at prediction frequency.

## TEST DATA

---

### Test Result :

The maximum antenna gain of **ACA-5036-A2-CC-S** made by **INPAQ TECHNOLOGY CO.,LTD.** is **3.0 dBi or 2.0(Numeric)**

Maximum peak output power at antenna input terminal:	<u>2.72</u> (dBm)
Maximum peak output power at antenna input terminal:	<u>1.870682</u> (mW)
Antenna gain(typical):	<u>3</u> (dBi)
Maximum antenna gain:	<u>1.995262</u> (numeric)
Prediction distance:	<u>20</u> (cm)
Prediction frequency:	<u>2441</u> (MHz)
MPE limit for uncontrolled exposure at prediction frequency:	<u>1</u> (mW/cm <sup>2</sup> )
Maximum allowable antenna gain:	34.2927 (dBi)
Maximum Distance:	0.544998 (cm)

**Power density at prediction frequency : 0.000743 (mW/cm<sup>2</sup>)**

## 10. ACCURACY OF MEASUREMENT

The Measurement Uncertainties stated were calculated in accordance with the requirements of NIST Technical Note 1297 with the confidence level of 95%

### 1. Radiation Uncertainty Calculation

<i>Contribution</i>	<i>Probability Distribution</i>	<i>Uncertainty(+/-dB)</i>
Antenna Factor	Normal (k=2)	± 0.5
Cable Loss	Normal (k=2)	± 0.04
Receiver Specification	Rectangular	± 2.0
Antenna directivity	Rectangular	± 1.0
Antenna Factor variation with Height		
Antenna Phase Center Variation		
Antenna Factor Frequency Interpolation		
Measurement Distance Variation		
Site Imperfections	Rectangular	± 2.0
Mismatch:Receiver VRC $r_i=0.3$ Antenna VRC $r_R=0.1(B_i)0.4(L_p)$ Uncertainty Limits $20\text{Log}(1+/-r_i r_R)$	U-Shaped	+ 0.25 / - 0.26
System Repeatibility	Std.deviation	± 0.05
Repeatability of EUT	-	-
Combined Standard Uncertainty	Normal	± 1.77
Expanded Uncertainty U	Normal (k=2)	± 3.5

### 2. Conducted Uncertainty Calculation

<i>Contribution</i>	<i>Probability Distribution</i>	<i>Uncertainty(+/-dB)</i>
Receiver Specification	Normal (k=2)	± 2.0
LISN coupling spec.	Normal (k=2)	± 0.4
Cable and input attenuator cal.	Rectangular	± 0.4
Mismatch:Receiver VRC $r_i=0.3$ LISN vrc $r_g=0.1$ Uncertainty Limits $20\text{Log}(1+/-r_i r_R)$	U-Shaped	± 0.26
System Repeatibility	Std.deviation	± 0.68
Repeatability of EUT	-	-
Combined Standard Uncertainty	Normal	± 1.18
Expanded Uncertainty U	Normal (k=2)	± 2.4

## 11. TEST EQUIPMENT

No.	Instrument	Manufacturer	Model	Serial No.	Calibration Date	Calibration Interval
1	*Test Receiver	R & S	ESCS 30	833364/020	Mar. 28 2009	1 year
2	*Test Receiver	R & S	ESCS 30	100302	Dec. 04 2008	1 year
3	*Amplifier	HP	8447F	2805A03427	Jul. 20 2009	1 year
4	*Amplifier	Sonoma Instrum	310N	291916	Jul. 22 2009	1 year
5	*Pre Amplifier	HP	8449B	3008A00107	Feb. 12 2009	1 year
6	*Pre Amplifier	HP	8447F	2805A03406	Apr. 09 2009	1 year
7	*Spectrum Analyzer	Agilent	E4440A	MY44303257	Jul. 20 2009	1 year
8	*Spectrum Analyzer	Agilent	E4440A	MY44022567	Sep. 04 2009	1 year
9	*Loop Antenna	EMCO	6502	8911-2436	Jan. 11 2009	2 year
10	*Spectrum Analyzer	R & S	FSP40	100361	Sep. 04 2009	1 year
11	Biconical Log Antenna	ARA	LPB-2520/A	1180	Apr. 21 2008	2 years
12	*Biconical Log Anter	ARA	LPB-2520/A	1209	Dec. 08 2008	2 years
13	*Horn Antenna	SCHWARZBECK	BBHA9120D	9120D-508	Dec.11 2008	2 years
14	*Trilog-Broadband Antenna	SCHWARZBECK	VULB 9168	9168-257	Apr. 21 2008	2 years
15	*Horn Antenna	SCHWARZBECK	BBHA9170	9170223	Jun. 16 2008	2 years
16	Signal Generater	R & S	SMP02	833286/003	Jul. 20 2009	1 year
17	*LISN	R & S	ESH3-Z5	833874/006	Nov. 11 2008	1 year
18	*LISN	R & S	ESH2-Z5	100227	Feb. 13 2009	1 year
19	*Position Controller	DAEIL EMC	N/A	N/A	N/A	N/A
20	*Turn Table	DAEIL EMC	N/A	N/A	N/A	N/A
21	*Antenna Mast	DAEIL EMC	N/A	N/A	N/A	N/A
22	*Anechoic Chamber	EM Eng.	N/A	N/A	N/A	N/A
23	*Shielded Room	EM Eng.	N/A	N/A	N/A	N/A
24	*Position Controller	Seo-Young EMC	N/A	N/A	N/A	N/A
25	*Turn Table	Seo-Young EMC	N/A	N/A	N/A	N/A
26	*Antenna Mast	Seo-Young EMC	N/A	N/A	N/A	N/A
27	*Anechoic Chamber	Seo-Young EMC	N/A	N/A	N/A	N/A
28	*Shielded Room	Seo-Young EMC	N/A	N/A	N/A	N/A

\*) Test equipment used during the test