

EMC TEST REPORT

Samsung Electronics Co., Ltd. 416 Maetan 3-Dong, Yeongtong-Gu, Suwon-Si, Gyeonggi-Do, 443-742 Korea (Tel: 82 31 277 7752, Fax: 82 31 277 7753)	Project No. : LBE070753 Page (1)/(20)	
--	--	---

1. Applicant

- Name of organization : **Samsung Electronics Co., Ltd.**
- Address : 416 Maetan 3-Dong, Yeongtong-Gu, Suwon-Si, Gyeonggi-Do
443-742 Korea

2. Purpose for the report : Approval for EMC

3. Kind of product : **Notebook Computer**
(Model name : NP-Q1u, Brand name : SAMSUNG)

4. Date of test : 2007. 3. 6 ~ 2007. 3. 7

5. Applied standard : FCC Part 15 B, Class B

6. FCC ID : **A3L-NP-Q1U**

7. Test result : Complied

The equipment under test has found to be compliant with the applied standards.
 (Refer to the attached test result for more detail.)

Tested by Name : Sang Kyu, Seo 	Reviewed by Name : No Cheon, Park 
--	---

This report is the test result about the sphere accredited by KOLAS which signed the Mutual Recognition Arrangement of International Laboratory Accreditation Cooperation.



2007. 3. 15

Samsung Electronics Co., Ltd.
Chief of CS Management Center

Table of contents

1. General information

- 1.1 Basic information related product
- 1.2 Detail information related product
- 1.3 Operating mode and condition
- 1.4 Equipment modifications
- 1.5 Test procedure
- 1.6 Test configuration
- 1.7 Applied standard
- 1.8 Test facility

2. Summary of test results

3. Description of individual tests

- 3.1 Conducted Emission
- 3.2 Radiated Emission

4. Appendix

- 4.1 Test photography
- 4.2 EUT photography

1. General information

1.1 Basic information related product

Applicant	Samsung Electronics Co., Ltd.
Model name	NP-Q1u
Applicant address	416 Maetan 3-Dong, Yeongtong-Gu, Suwon-Si, Gyeonggi-Do 443-742 Korea
Contact person	John SC LEE
Kind of product	Notebook Computer
Variant model	Q1u
Manufacturer	Samsung Electronics Co., Ltd. 416 Maetan 3-Dong, Yeongtong-Gu, Suwon-Si, Gyeonggi-Do 443-742 Korea
Rated power	AC 120 V, 60 Hz
New / Alternative / Permissive change information	New

1.2 Detail Information related product

1.2.1 Specification

Item	Specification	Remark
CPU	Intel Stealey CPU (ULV 800MHz) (Cache 512MB, 400Mhz FSB)	-
Chipset	Intel Little River + ICH7U	-
Main Memory	Samsung, DDR2, 1GB	-
Graphic controller	Intel Little River Internal Graphic (GMA950 Base)	-
DISPLAY	Samsung, LTP700WS-F01, 7", WSVGA (1024 x 600) with TSP	-
HDD	Toshiba 4200 rpm 1.8" 60GB	-
LAN	Broadcom BCM4401E 10/100 PCI Ethernet Controller	-
Wireless LAN	Atheros / Askey, AR5BXB61 KR, 802.11bg, 54Mbps, Mini-card MIC No.: ATH-AR5BXB61, FCC ID:PPD-AR5BXB61	-
Bluetooth	Broadcom, BCM92045NMD, USB 2.0 type, Bluetooth Ver 2.0 Foxconn Module, MIC No.:R-LARN-05-0240	-
ADAPTER	Lishin, 0335C1960, AD-6019, 60W, 19Vdc, 2pin	-
Battery	Sanyo (4cells, Smart Li-Ion Battery)	-
Sound	1.5W 2 Stereo Speaker, Array Mic	-
Input Devices	Keypad, Hall Mouse, TSP, Touchsensor Button, UDF Button	-
Ports	LAN, 2 USB, 1 VGA, DC IN, 1HP-OUT, SD Card socket, Power/Hold, MIO, Shutter Button, Dialkey, User_Define(4 UDF + 1 Launcher) Mode Switch (8-Way/Pointing Stick), Touch Sensor Button	-

Operating Frequency

800MHz(CPU Speed), 100MHz(Host Clock), 400MHz(DDR2),
33MHz(PCI Clock), 100MHz (PCIE Clock), 14.318MHz(Ref), 10MHz(MICOM Clock),
66Mhz(RGB encoder), 25Mhz(LAN controller), 24MHz(Audio CODEC)

1.3 Operating mode and condition

The EUT exercise program used during radiated and conducted emissions testing was the Samsung Standardized Emission Test Program for Windows. During the certification test, the LCD panel was open and video signals were simultaneously active on the LCD panel, and the VGA port.

The system was configured for testing in a typical fashion that a customer would normally use, and was tested while in an automated non-attendant mode.

The program repetitively sends a screen of 'H' to the display, reads and writes to the hard drive.

Musics are played from the CD player which connected externally to the Line-In jack and ported out to the earphones.

A hard drive from the remote PC was mapped to the EUT and a data file was read and written over the network connection to provide continuous activity. The EUT was connected to a remote PC through the Ethernet port with Unshielded Twisted Pair Ethernet cable. Ethernet testing was performed at 1Gbps operation. Cables were attached to each of the available I/O Ports. Where applicable, peripherals were attached to the I/O cables. Also a camera which is in the EUT is run during the test.

The EUT was tested with the WLAN communicating during the radiated immunity testing. The hopping channels of the Bluetooth hopped and operated in the 2400-2483.5 MHz band, with 79 channels

- Test Voltage : AC 120 V, 60 Hz

1.4 Equipment modifications

This section provide details of the equipment under test(EUT)and the peripheral assemblies attached during radiated and conducted emission testing.

The AC adapter was connected and All external peripherals were connected to the I/O ports to the EUT.

1.5 Test procedure

1.5.1 Conducted emission

EUT was placed on a platform nominal size, 1 m by 1.5 m, raised 80 cm above the conducting ground plane. The rear of tabletop was located 40 cm to the vertical conducting ground plane.

The rear of EUT, including peripherals was aligned and flush with rear of tabletop.

All other surfaces of tabletop was at least 80 cm from any other grounded conducting surface.

I/O cables and AC cables that were connected to the peripherals were bundled in center.

They were folded back and forth forming a bindle 30 cm to 40 cm long and were handed at a 40 cm height to the ground plane.

Each EUT current-carrying power lead, except the ground(safety) lead, were individually connected through a LISN to the input power source.

All unused 50 ohm connectors of the LISN were resistively terminated in 50 ohm when not connected to the measuring equipment.

Frequency Band [MHz]	Instrument	Detector	Resolution Bandwidth	Video Bandwidth
0.15 to 30	EMI Receiver	Quasi-Peak	9 kHz	-
		Average	9 kHz	-

1.5.2 Radiated emission

EUT was placed on a platform of nominal size, 1 m by 1.5 m, raised 80 cm above the conducting ground plane. The rear of EUT, including peripherals was aligned and flush with rear of tabletop.

The I/O cables that were connected to the peripherals were bundle in center.

They were folded back and forth forming a bundle 30 cm to 40 cm long and were hanged 40 cm height to the ground plane.

Test was made with the antenna positioned in both the horizontal and vertical planes of polarization.

The measurement antenna was varied in height above the conducting ground plane and the trun table azimuth was varied to obtain the maximum signal strength

The system configuration, clock speed, mode of operation or video resolution, turntable azimuth with respect to the antenna were noted for each frequency found.

The spectrum was scanned from 30 to 1 000 MHz using biconiLog antenna.

Frequency Band [MHz]	Instrument	Detector	Resolution Bandwidth	Video Bandwidth
30 to 1 000	EMI Receiver	Quasi-Peak	120 kHz	-
Above 1 000	EMI Receiver	Peak	1 MHz	1 MHz

1.6 Test configuration

1.6.1 Used EUT and peripherals

Seq	Device	Model Name	Serial #	Maker	Note
A	Notebook PC	NP-Q1u	-	Samsung	EUT
B	AC Adapter	AD-6019	CNBA4400238AD2VH6CN0165	Li Shin	For EUT
C	Monitor	CX712MP	-	Samsung	-
D	AC Adapter	PSCV360104A	C020381825B	Dongguan Samsung Electro-Mechanics	-
E	USB mouse	MS201U	69G1948	Monterey International Corp.	-
F	USB ODD	-	-	Samsung	-
G	Headset	Axis-202	-	Labtec	

1.6.2 Used cable description

No	Connect Cable	Length [m]	Shielded [Y/N]	Remark
1	Power	1.8	No	For n/pc
2	Power	1.8	No	For monitor
3	Monitor	1.8	Yes	From pc to monitor
4	USB	1.8	Yes	From pc to mouse
5	Headset	1.6	Yes	From pc to headset
6	LAN	1.8	Yes	From pc to lan

1.6.3 Block Diagram

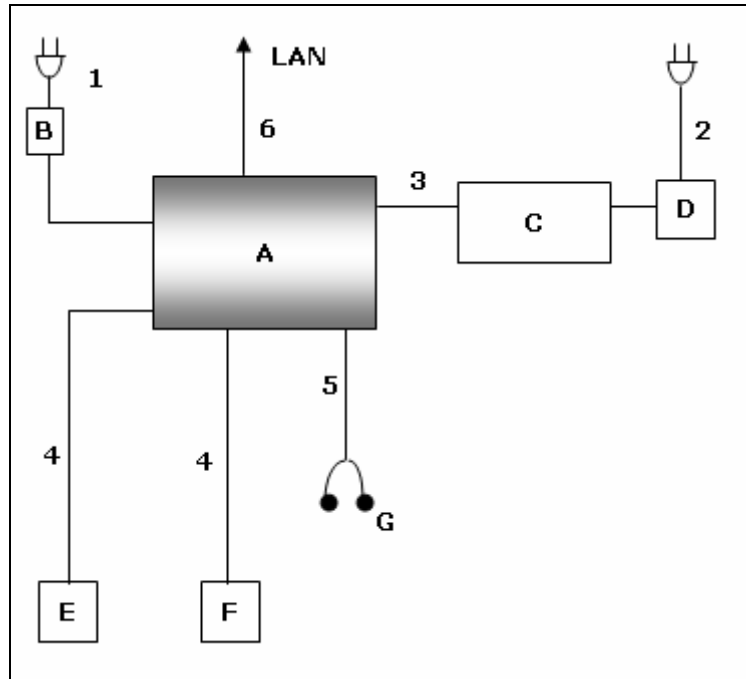

1.7 Applied Standards

Test standard	Test method
FCC Part 15 B	ANSI C63.4:2003

1.8 Test Facility

1.8.1 General information

The sites are constructed in conformance with the requirements of ANSI C63.4 and CISPR 22, 16-1, 16-2.

This EMC Testing Lab. is accredited by Korea Laboratory Accreditation Scheme(KOLAS) which signed the International Laboratory Accreditation Cooperation (ILAC) Mutual Recognition Arrangement (MRA) for the above test item(s) and test method(s).

This Lab. is operated as testing laboratory in accordance with the requirements of ISO/IEC 17025:1998.

1.8.2 Accreditation and listing



1.8.3 Measurement uncertainty

(According to CISPR 16-4 and Lab. 34)

Test item	Measurement uncertainty
Conducted emission	± 2.8 dB
Radiated emission (Bi-Log Antenna)	± 5.1 dB
	± 5.09 dB

2. Summary of test results

Result : Complied

The equipment under test (EUT) has been found to comply with the applied standards.

Section of the Product Standard	Applied Standard	Result	
Electromagnetic Emission Test			
3.1	Conducted Emission	FCC Part 15 B	Complied
3.2	Radiated Emission	FCC Part 15 B	Complied

3. Description of individual tests

3.1 Conducted emission

3.1.1 Test information

Test engineer	Sang Kyu, Seo
Test date	March 7, 2007
Climate condition	Ambient temperature : 24.6 , Relative humidity : 26 % Atmospheric pressure : 101.4 kPa
Test place	Shielded room #1

3.1.2 Test equipment

Equipment	Model name	Manufacturer	Serial no.	Calibration	
				Date	Interval (Month)
EMI TEST RECEIVER	ESCI	R&S	100369	2006-05-01	12
LISN (For EUT)	ENV216	R&S	100116	2006-09-01	12
LISN (For Peripheral)	ESH3-Z5	R&S	100261	2006-07-21	12
Test Software	EMC 32	R&S	Ver 4.40.0	N/A	N/A

3.1.3 Test result : **Complied**

The Measured emissions of the EUT have found to be below the specified limits.

3.1.4.1 Test graph

Test Information

Test Description: NP-Q1u_01
 Operating Conditions:
 Operator Name:
 Comment:

Hardware Setup: Voltage with ENV 2-Line-LISN - [EMI conducted]

Subrange 1
 Frequency Range: 150kHz - 30MHz
 Receiver: ESCI 3 [ESCI 3]
 @ GPIB0 (ADR 20), SN 100369/003, FW 3.82
 Signal Path: Receiver-2-Line-LISN ENV216
 FW 1.0
 Correction Table: Receiver-2-LISN ENV216
 LISN: ENV216
 Correction Table (Line 0): ENV216_100116_N
 Correction Table (Line 1): ENV216_100116_L

Scan Setup: FCC Part 15 Class_B with ENV 2-Line-LISN fin [EMI conducted]

Hardware Setup: Voltage with ENV 2-Line-LISN
 Level Unit: dB μ V

Subrange	Detectors	IF Bandwidth	Meas. Time	Receiver
150kHz - 30MHz	QuasiPeak; Average	9kHz	15s	ESCI 3

FCC Part 15 Class_B with ENV 2-Line-LISN

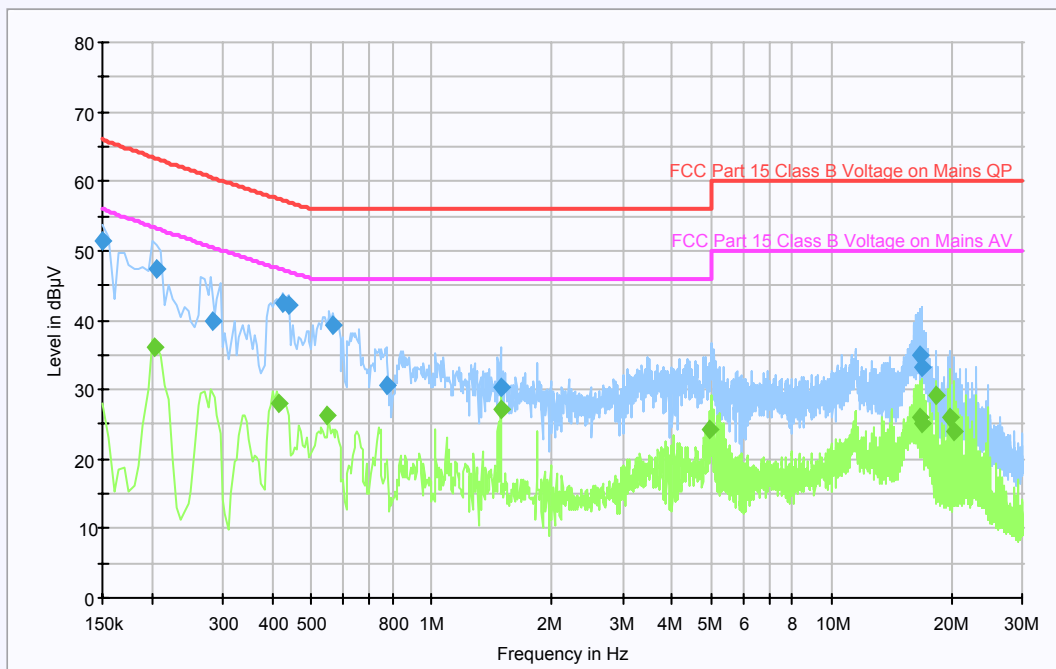

Final Measurement Detector 1

Frequency (MHz)	QuasiPeak (dB μ V)	Line	Corr. (dB)	Margin (dB)	Limit (dB μ V)
0.150 000	51.6	L1	9.6	14.4	66.0
0.204 500	47.3	N	9.6	16.0	63.3
0.283 500	39.9	N	9.6	20.6	60.5
0.424 500	42.5	N	9.6	14.8	57.3
0.439 500	42.2	N	9.6	14.8	57.0
0.564 500	39.1	N	9.6	16.9	56.0
0.769 500	30.7	N	9.6	25.3	56.0
1.484 500	30.3	N	9.7	25.7	56.0
16.580 500	34.9	L1	10.0	25.1	60.0
16.809 500	33.2	L1	10.0	26.8	60.0

Final Measurement Detector 2

Frequency (MHz)	Average (dB μ V)	Line	Corr. (dB)	Margin (dB)	Limit (dB μ V)
0.203 500	36.1	N	9.6	17.2	53.3
0.414 500	28.0	N	9.6	19.4	47.4
0.549 500	26.2	N	9.6	19.8	46.0
1.484 500	27.2	N	9.7	18.8	46.0
4.969 500	24.3	L1	9.8	21.7	46.0
16.585 500	25.9	L1	10.0	24.1	50.0
16.829 500	25.2	L1	10.0	24.8	50.0
18.239 500	29.2	L1	10.1	20.8	50.0
19.708 500	26.0	N	10.1	24.0	50.0
20.254 500	23.9	N	10.1	26.1	50.0

* QP : Quasi-peak, AV: Average

* Level (QuasiPeak or Average) = Meter Reading(QP or AV) + Corr. (LISN Insertion loss + Cable loss)

* Margin = Limit – Result

3.2 Radiated Emission

3.2.1 Test information

Test engineer	Sang Kyu, Seo
Test date	March 6, 2007
Climate condition	Ambient temperature : 24.3 , Relative humidity : 22 % Atmospheric pressure : 102.1 kPa
Test place	10m Semi Anechoic Chamber

3.2.2 Test equipment

Equipment	Model name	Manufacturer	Serial no.	Calibration	
				Date	Interval (Month)
Bi-con Antenna	CBL6112D	SCHAFFNER	22601	2006-06-26	12
Bi-con Antenna	CBL6112D	SCHAFFNER	22602	2006-06-26	12
EMI Receiver	ESI-26	R&S	832692/002	2007-02-28	12
EMI Receiver	ESI-26	R&S	100288	2006-04-04	12
AMPLIFIER	310N	SONOMA	251674	2006-03-14	12
AMPLIFIER	310N	SONOMA	186465	2006-03-17	12
Ant Mast	MA4000	Inn-co	-	N/A	N/A
Ant Mast	MA4000	Inn-co	-	N/A	N/A
Mast Controller	CO2000	Inn-co	-	N/A	N/A
RF Selector	NS4900	TOYO	-	N/A	N/A

3.2.3 Test result : **Complied**

The Measured emissions of the EUT have found to be below the specified limits.

3.2.4 Test data

(1). 30MHz – 1GHz

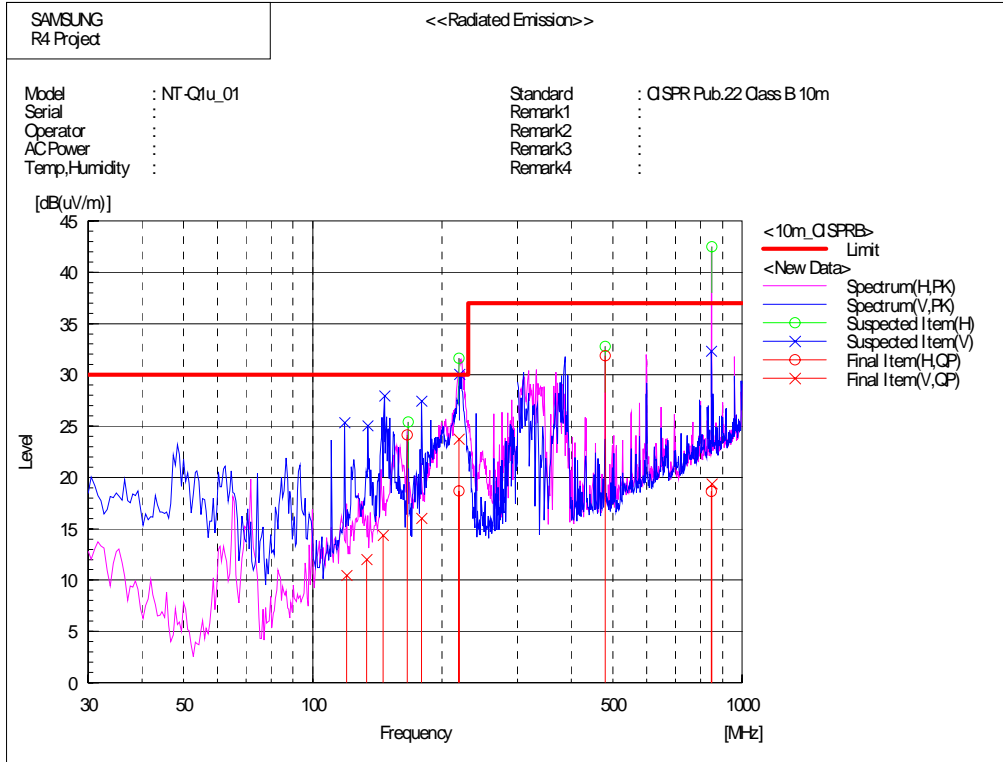

Final Result

--- Horizontal Polarization (QP)---

No.	Frequency [MHz]	Reading [dB(uV)]	c.f [dB(1/m)]	Result [dB(uV/m)]	Limit [dB(uV/m)]	Margin [dB]	Remark
1	848.714	22.3	-3.7	18.6	37.0	18.4	
2	219.046	38.7	-20.0	18.7	30.0	11.3	
3	479.945	41.1	-9.3	31.8	37.0	5.2	
4	165.917	43.8	-19.6	24.2	30.0	5.8	

--- Vertical Polarization (QP)---

No.	Frequency [MHz]	Reading [dB(uV)]	c.f [dB(1/m)]	Result [dB(uV/m)]	Limit [dB(uV/m)]	Margin [dB]	Remark
1	218.905	43.5	-19.7	23.8	30.0	6.2	
2	146.027	32.9	-18.5	14.4	30.0	15.6	
3	179.152	36.1	-20.1	16.0	30.0	14.0	
4	120.001	28.0	-17.5	10.5	30.0	19.5	
5	849.949	23.3	-3.9	19.4	37.0	17.6	
6	133.479	29.6	-17.6	12.0	30.0	18.0	

- * Receiving Antenna Mode : Horizontal, Vertical
- * Test distance : 10 m (Semi-Anechoic Chamber)
- * Result = Meter Reading + c.f (Antenna factor + Cable loss-Amp. Gain)
- * Margin = Limit – Result

(2). 1GHz – 5GHz

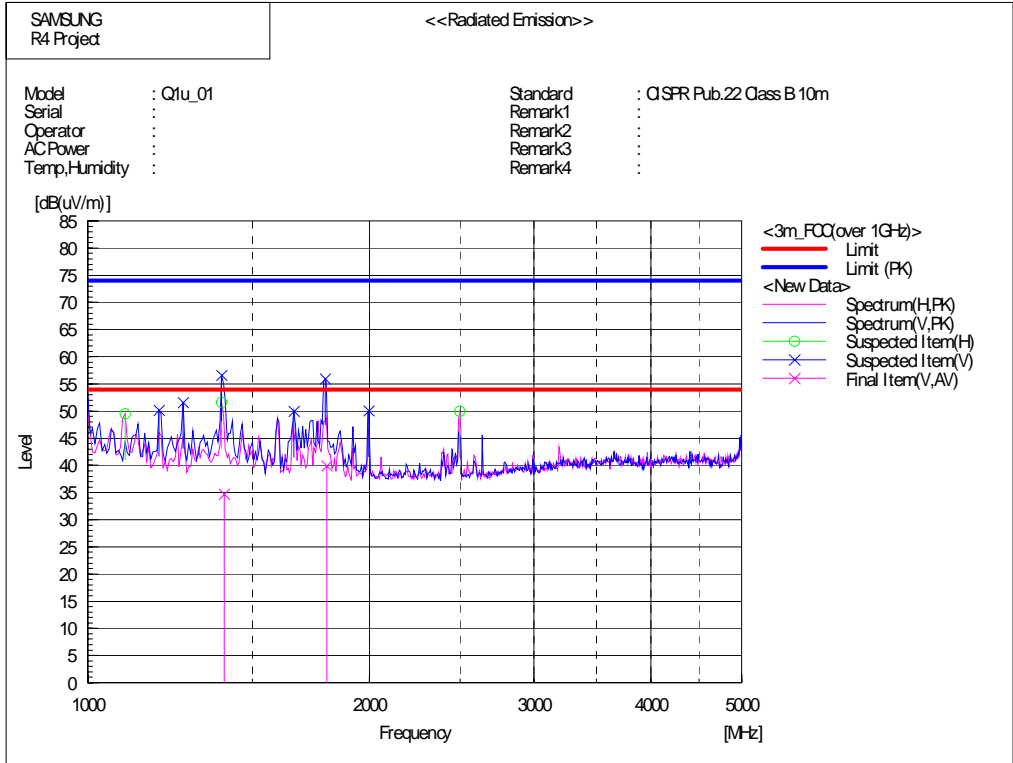

Final Result

--- Vertical Polarization (AV)---

No.	Frequency [MHz]	Reading [dB(uV)]	c.f [dB(1/m)]	Result [dB(uV/m)]	Limit [dB(uV/m)]	Margin [dB]	Remark
1	1398.357	39.7	-5.0	34.7	54.0	19.3	
2	1800.862	43.1	-3.1	40.0	54.0	14.0	

* Measurement detector function and bandwidth

- Detector function : peak

- Bandwidth : 1MHz

* Receiving Antenna Mode : Horizontal, Vertical

* Test distance : 3 m (Semi-Anechoic Chamber)

* Result = Meter Reading + c.f (Antenna factor + Cable loss-Amp. Gain)

* Margin = Limit – Result