



# User's Guide

**SV-LCD3**

**MODEL NO.: KMV1610**



## Important Safety Instructions

<p><b>CAUTION</b> RISK OF ELECTRIC SHOCK DO NOT OPEN</p>		<p>This symbol indicates the presence of high voltage in the unit. It is dangerous to make any kind of contact with any inside part of this product.</p>
<p><b>CAUTION</b> TO REDUCE THE RISK OF ELECTRIC SHOCK, DO NOT REMOVE COVER (OR BACK). NO USER SERVICEABLE PARTS INSIDE. REFER SERVICING TO QUALIFIED PERSONNEL.</p>		<p>This symbol alerts you that important literature concerning operation and maintenance has been included with this product.</p>

### CAUTION

FCC REGULATIONS STATE THAT ANY UNAUTHORIZED CHANGES OR MODIFICATIONS TO THIS EQUIPMENT MAY VOID THE USER'S AUTHORITY TO OPERATE IT.

**IMPORTANT** : One Federal Court has held that unauthorized recording of copyrighted TV programs is an infringement of U.S. copyright laws.

Certain Canadian programs may be copyrighted and any unauthorized recording in whole or in part may be a violation of these rights.

**To prevent damage which may result in fire or electric shock hazard, do not expose this appliance to rain or moisture.**

## Important Safeguards

1. **Read Instructions** - Read all safety and operating instructions before operating the product.
2. **Retain Instructions** - Retain all safety and operating instructions for future reference.
3. **Heed Warnings** - Adhere to all warnings on the product and in the operating instructions.
4. **Follow Instructions** - Follow all operating and use instructions.
5. **Cleaning** - Unplug from power source before cleaning. Use damp cloth only; do not use liquid or aerosol cleaners.

6. **Attachments and Connections** - Do not use attachments or make any connections other than those recommended by the manufacturer.
7. **Ventilation** - Slots and openings in the cabinet are provided for ventilation. To ensure reliable operation of the product and to protect against overheating, these openings must not be blocked or covered. The openings must not be placed on any surface or positioned in any way that will cause these openings to be blocked or covered.
8. **Power Cord Wiring Harness** - The power cord should be routed in such a way that it is not likely to be stepped on, have objects placed on it, or hinder operation of a vehicle in any way.
9. **Unit Placement** - The unit should be positioned on a flat, sturdy surface and secured in such a way that it cannot move freely about the passenger compartment or hinder operation of a vehicle in any way.
10. **Object and Liquid Entry** - Never insert objects (other than video cassette tapes, as instructed) in to this product. Electric shock, fire or electric shortout can occur. Never spill/pour liquid of any kind onto/into this product.
11. **Servicing** - Do not attempt to service this product yourself; opening or removing the covers may expose you to dangerous electric voltage or other hazards. Refer all servicing to qualified service personnel.
12. **Damage Requiring Service** - Unplug this product from the power source and refer to qualified service personnel for the following:
  - a. If the power supply cord or plug is damaged.
  - b. If liquid has spilled into or objects have been dropped onto the product.
  - c. If the product has been exposed to rain or water.
  - d. If the product does not operate normally according to the operating instructions. Adjust only those controls covered by the operating instructions, as improper adjustment of other controls can cause damage and can require extensive repair work by a qualified technician to restore normal operation.
  - e. If the product has been dropped or damaged in any way.
  - f. If the product exhibits a distinct change in performance.
13. **Replacement Parts** - When replacement parts are required, be sure the service technician uses replacement parts specified by the manufacturer or that have the same characteristics as the original part. Unauthorized substitutions may result in fire, electric shock, or other hazards.
14. **Safety Check** - Upon completion of any service or repairs to this product, ask the service technician to perform safety checks to determine that the product is in proper operating condition.
15. **Heat** - The product should be situated away from heat sources devices such as radiators, heat registers, stoves, or other products (including amplifiers) that produce heat.

# Table of Contents

- Features and Accessories** ..... 5
  - Features ..... 5
  - Accessories ..... 5
- Front Panel** ..... 6
- Installation** ..... 6
- Rear Panel/Monitor Connection/Power** ..... 7
- Remote Control** ..... 8
- Remote Control Battery Install/Replace** ..... 8
- Playing a Tape** ..... 9
  - Manual Tracking ..... 9
- Using Special Features** ..... 9
  - Forward and Reverse Picture Search ..... 9
  - Forward and Reverse Jet Search ..... 9
  - Still and Frame Advance ..... 9
  - Slow Motion Playback ..... 9
- Setting the Setup Menu** ..... 10
  - On Screen Menu ..... 10
  - Record Speed ..... 10
  - Auto Repeat ..... 10
  - Audio Output ..... 10
  - Channel Setup ..... 11
  - VCR Output CH ..... 11
- Videocassette Tapes** ..... 12
  - About Videocassettes ..... 12
- Recording** ..... 13
- Cleaning and Care** ..... 13
  - Video Head Cleaning ..... 13
- Troubleshooting** ..... 14
- Specifications** ..... 15

# Features and Accessories

## Features

- ◆ Hi-Fi stereo
- ◆ Audio/Video Inputs
- ◆ Digital Auto Tracking
- ◆ Built-in HQ (High Quality) video circuitry
- ◆ Frame Advance and Slow Motion
- ◆ DLC (Diamond Like Carbon) Head - special alloy reduces head wear and increases durability
- ◆ Infrared Remote Control
- ◆ On Screen Display

## Accessories

Check that you have received the following:

- ◆ VCR
- ◆ VCR user's guide
- ◆ Remote control
- ◆ Batteries
- ◆ Power harness
- ◆ VCR Mount Bracket(2Piece)
- ◆ Installation Screw
- ◆ Remote control Sensor
- ◆ TFT-LCD(6.8 inch)

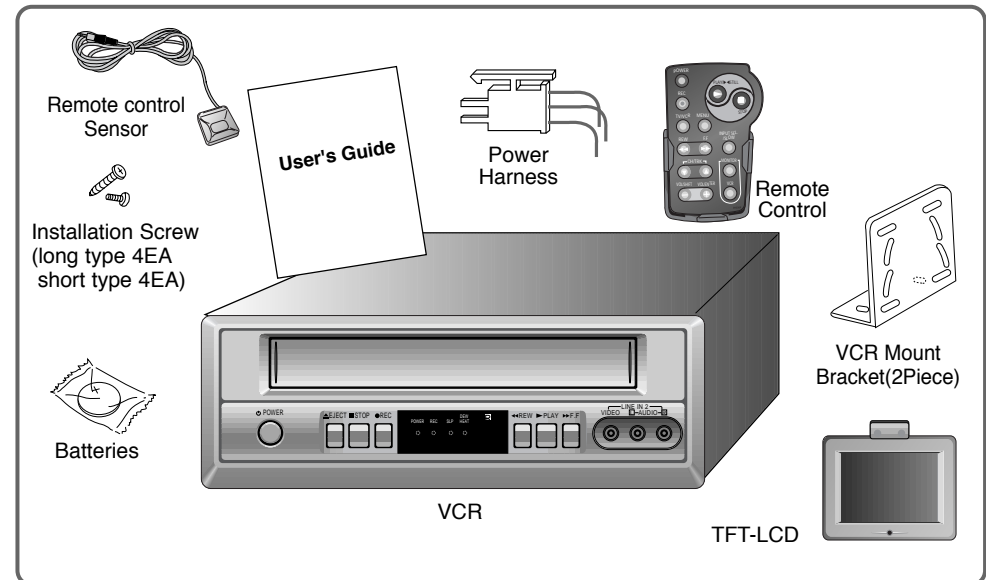

## Front Panel

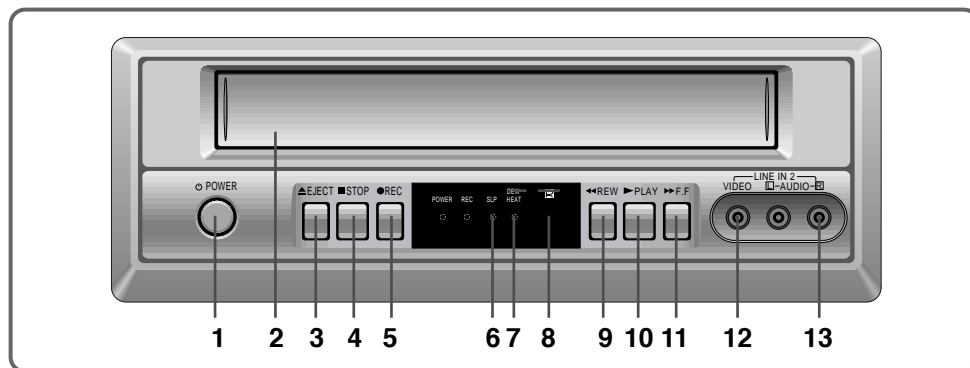

- 1. POWER**  
Turns VCR on and off.
- 2. Cassette Compartment**  
For cassette insertion/removal.
- 3. EJECT**  
Ejects cassette.
- 4. STOP**  
Stops tape movement.
- 5. REC**  
Starts recording.
- 6. SP/SLP Indicator**  
Lit when VCR is recording in SLP mode.
- 7. DEW/HEAT Indicator**  
When DEW/HEAT indicator is blinking and "DEW/HEAT" is displayed on the monitor screen, the VCR will not be able to work, which shows the VCR is under a high moist circumstance or VCR is overheated. Then the VCR will turn to standby and dry itself. When moisture disappears, the VCR will work normally.
- 8. Remote Sensor Eye**
- 9. REW**  
Rewinds tape from stop mode.
- 10. PLAY**  
Press to begin playback.
- 11. FF**  
Fast forwards tape from stop mode.
- 12. VIDEO IN JACK**  
Use to input video signal from connected equipment.
- 13. AUDIO IN L/R JACKS(LINE IN 2)**  
Use to input audio signal from connected equipment.

## Installation

The VCR can be mounted vertically, horizontally or at any angle in between with the optional mounting brackets. The VCR cannot be mounted upside down or on its side. VCR is sensitive to dirt and other contaminants. Do not mount the unit in direct sunlight, on the floor near heavy traffic areas or where fluids are likely to spill on or in the unit. The VCR is for 12Volt negative ground vehicles only.

## Rear Panel/Monitor Connection/Power

To connect the VCR and monitor, use cable type (multi-Cable) appropriate to your monitor. Connect the VCR to the monitor as shown:

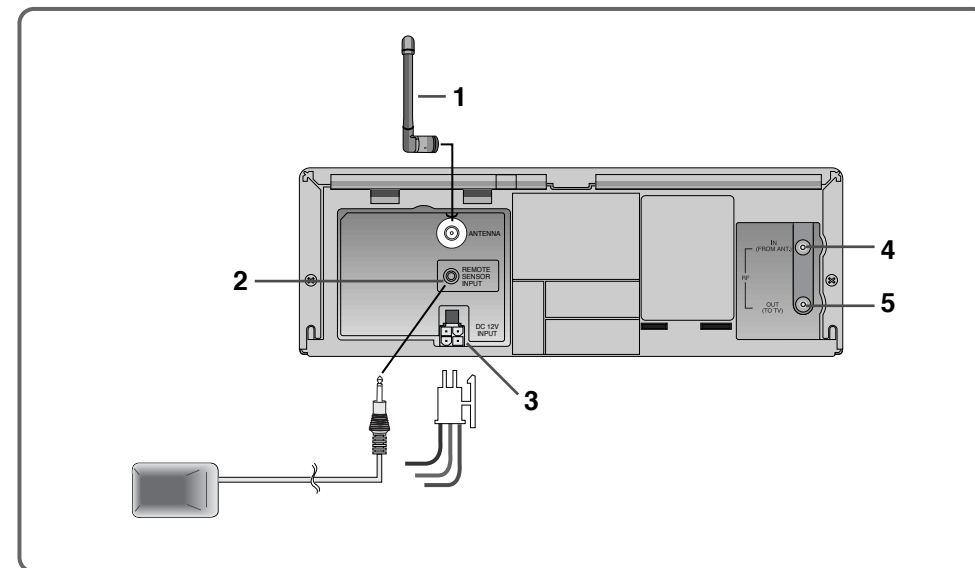

- 1. ANTENNA**
  - 2. REMOTE SENSOR INPUT**
  - 3. DC 12V INPUT**  
To provide power for the VCR, connect the small plug end of the power harness on the back of the VCR.
  - 4. IN FROM ANT**  
Use to input cable or antenna signal.
  - 5. OUT TO TV**  
Use to output VCR signal to a external TV (if you want).
- Blue:** This wire connects to a circuit that turns on and off with the key.  
**Red:** This wire connects to the battery or a constant power source.  
**Black:** This wire connects to a good factory ground wire or a metal part of the chassis.

## Remote Control

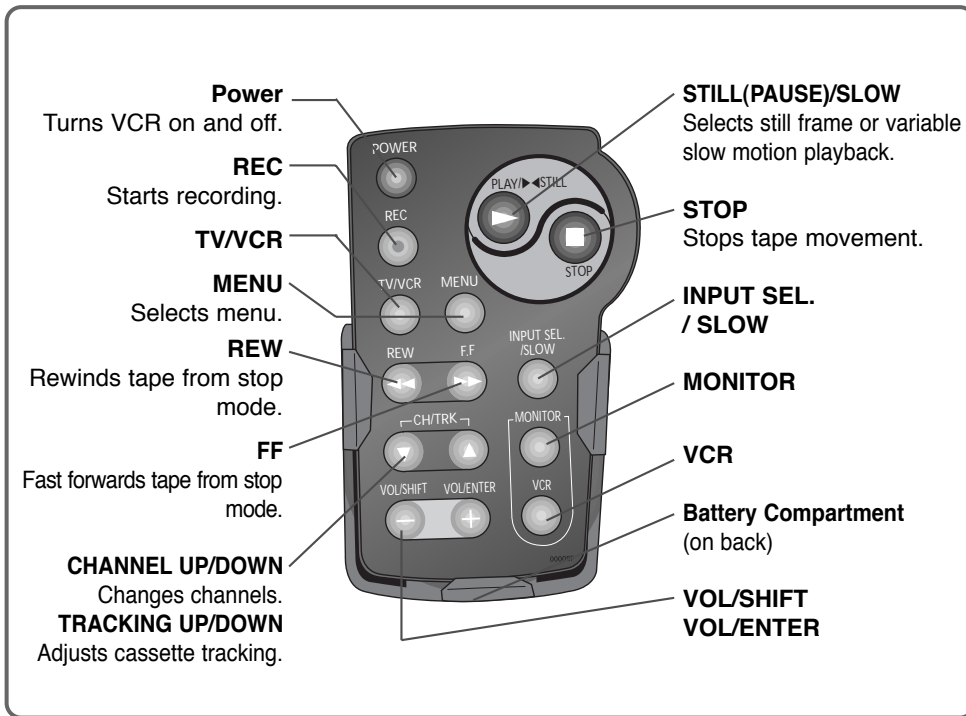

## Remote Control Battery Install/Replace

1. Slide battery compartment cover out from back of remote control.
2. Insert two AA batteries as diagrammed.
3. Slide battery compartment cover back in.



## Playing a Tape

1. Load a video cassette tape. Then, VCR power turns on automatically.
2. Press **PLAY** button to start playback.  
If the tape doesn't have a safety tab, VCR will playback automatically.  
When playback starts, the VCR automatically adjusts the tracking for clear picture and sound.
3. To stop playback, press **STOP** button.

### Manual Tracking

For best picture quality, the VCR video head must be aligned with the recorded track on the tape; this alignment is called tracking. Videocassettes recorded on other VCRs and videocassettes with copy protection may require some manual adjustment. To adjust manually, press **CH/TRK** button up or down as necessary until the best picture possible is achieved.

**Note:** Picture distortion often occurs at the beginning of a tape. Let the tape play for a moment to see if the distortion clears. If manual tracking adjustments do not produce a clear picture, there may be a problem with the videotape.

## Using Special Features

### Forward and Reverse Picture Search

While in Play mode, press **REW** button or **FF** button; to resume normal viewing, press **PLAY** button.

### Forward and Reverse Jet Search

While in Play mode, press and hold **REW** button or **FF** button; Jet Search increases the tape speed 7 times if recorded at SP speed or 21 times for tapes recorded at SLP speed. To resume normal viewing, release the button.

**Note:** While in Forward or Reverse Jet Search, audio is muted.

### Still and Frame Advance

While in Play mode, press **STILL/SLOW** to stop on a single still frame. Press **STILL/SLOW** button again to advance picture frame by frame. To resume normal viewing, press **PLAY** button.

**Note:** Using Still mode for more than five minutes stresses the tape and causes undue stress on the video heads; the VCR automatically disengages Still mode after five minutes have elapsed.

### Slow Motion Playback

Press **STILL/SLOW** button for more than 2 seconds for SLOW Motion Playback.

## Setting the Setup Menu

### On Screen Menu

Your VCR has on-screen menus that allow you to access and control the VCR's programmable features. You will use the buttons on the remote control to work with the on-screen programming. **CH/TRK ▲ / ▼** buttons also have the shift cursor function in the on screen.

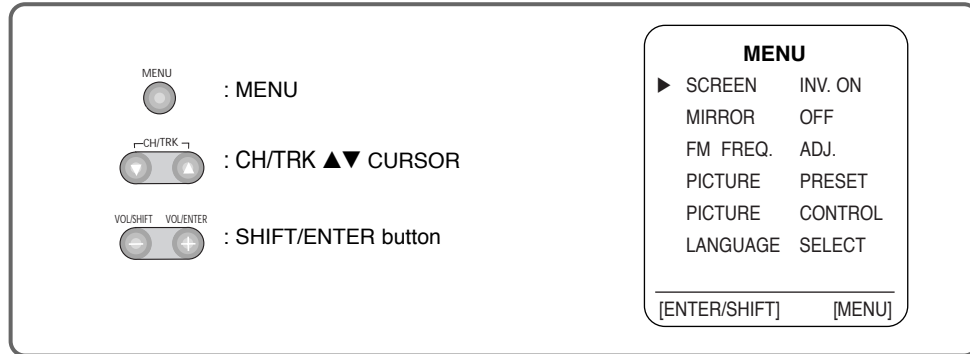

1. Press **MENU** button on your remote control. The Setup Menu will appear on screen.
2. Select the item you want to adjust using **ENTER** button followed by the **CH/TRK** button on your remote control.

To make all of the VCR's fetures available, set the VCR functions before playing or recording a tape.

### SCREEN INV. ON

Select Screen Reset using **ENTER** button.

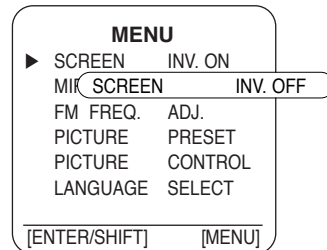

### MIRROR OFF

Select Mirror Reset using **ENTER** button.

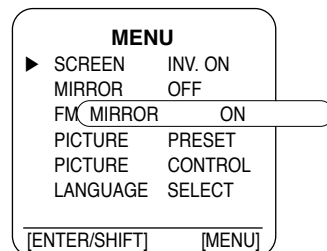

## Setting the Setup Menu

### FM FREQ. ADJ.

Select FM Xmit.Freq. by pressing **ENTER** button, and you can enjoy the sound from this unit via your car stereo. Use the **CH/TRK ▲ / ▼** buttons key to select one of 10 frequencies from 90.7MHz to 92.5MHz. (A different FM station may be received during a long distance drive. In this case, retune the desired station as above.)

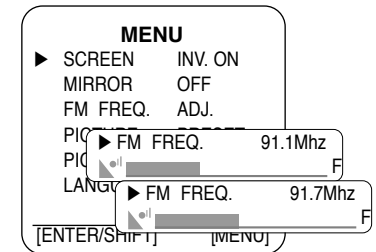

### PICTURE PRESET

Press **ENTER** button to activate the "PICTURE PRESET" Picture repeat set the VCR to play a tape repeatedly unless a tape control is activated(Stop, fast-foward or rewind.)

### PICTURE CONTROL

### Bright/Color/Sharuness/Tint

Select one of the menu options by pressing **ENTER** button to adjust the brightness, color, sharpness, or tint of the monitor as desired. Use the **CH/TRK ▲ / ▼** buttons key to select a new level from 0 to 63; 32 is standard.

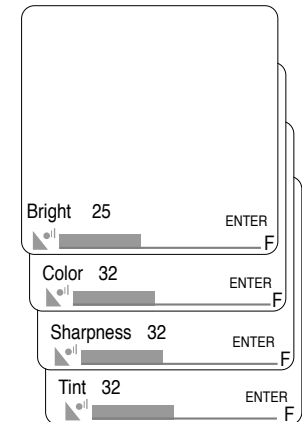

### LANGUAGE SELECT

Select Language Reset using **ENTER** button.

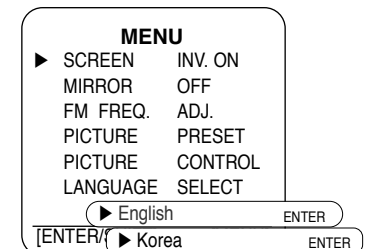

## Videocassette Tapes

Always insert the videocassette window-side up with the arrow on the case pointing toward the VCR.

Use only videocassette tapes marked **VHS**. European-standard PAL VHS videocassette tapes and S-VHS prerecorded videocassette tapes are not compatible.

To prevent accidentally recording over previously recorded material, remove the Record Protect Safety Tab on the videocassette case after recording.

To record a tape that has the Record Protect Safety Tab removed, place a piece of cellophane tape over the space from which the tab was removed.

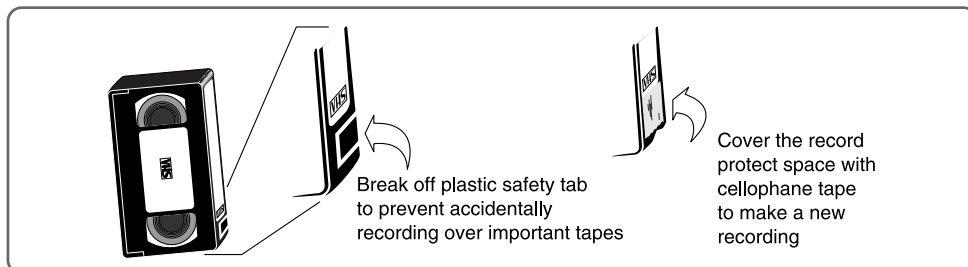

**Note:** The recording time available on a videocassette depends on Tape Speed (SP or SLP) and Cassette Type (T60 = 60 minutes at SP or 180 minutes at SLP; T120 = 120 minutes at SP or 360 minutes at SLP).

Tape	SP (standard play)	SLP (super long play)
T-120	2 hrs	6 hrs
T-160	2 hrs 40 minutes	8 hrs
T-180	3 hrs	9 hrs

**Note:** Keep cassettes from direct sunlight, heat or extreme cold. Do not drop cassettes. Never touch the recording surface of the tape.

### About Videocassettes

- In general, high-quality, brand name videocassettes last longer and provide a better picture.
- Rewind your cassettes all the way so that the tape is not at a midpoint; this can extend the tape life.
- Do not touch or splice the tape; this can damage the tape and playing such a tape can damage the VCR.
- Do not take apart any cassette you plan to use again.
- Do not put any object inside a videocassette and do not clean inside a videocassette; this can permanently damage the tape, making it unusable.

## Recording

1. Turn the VCR power on.
2. Insert videocassette tape.
3. Press **MENU** button on the remote control to access the "on screen menu". Use **CH/TRK ▲ / ▼** buttons to select the Record Speed function.  
Press **ENTER** button to select the desired recording speed.  
Press **MENU** button to exit.

**Note:** Tape speed can be changed while recording; there may be minor distortion but no interruption.

4. Select a channel to record by pressing **CH/TRK ▲ / ▼** buttons.

**Note:** Use **CH/TRK ▲ / ▼** buttons if you want to select the LINE IN 1 or LINE IN 2

5. Press **REC** button; REC indicator will light.
6. To pause recording, press **STILL/SLOW** button. To resume recording, press **REC** button.
7. To end recording, press **STOP** button.

## Cleaning and Care

- Disconnect the VCR from the power source before cleaning.
- Do not use liquid or aerosol cleaners on or in the VCR.
- Use a dry cloth to dust the VCR.
- Keep the remote control with the VCR and secure it in such a manner that it is unlikely to be lost or damaged.
- Keep liquids away from the VCR. A spill on the VCR can damage the electronics and cause electric shock or fire.

DO NOT INSERT ANY OBJECTS INTO THE CABINET SLOTS; CONTACT WITH A VOLTAGE POINT INSIDE THE VCR CAN CAUSE DANGEROUS SHOCK OR MAY SHORT OUT PARTS AND CAUSE FIRE OR ELECTRIC SHOCK.

### Video Head Cleaning

If poor playback qualities (snow, distortion, streaking, etc.) develop and persist, the unit's video heads may need cleaning. If necessary, purchase a head cleaning cassette. Do not clean the heads excessively.

**When using a head cleaning cassette, read all instructions carefully; incorrect head cleaning can permanently damage the video heads.**

## Troubleshooting

Before calling for service, check the following:

Problem	Solution
No power.	Make sure the VCR is on and connected to an operating power source; check the remote for "good" batteries.
Videocassette cannot be inserted.	Press <b>EJECT</b> button to see if a cassette is already in the VCR. Make sure the videocassette is window-side up, with the arrow pointing toward the VCR.
No picture, distorted picture on playback.	<ul style="list-style-type: none"> <li>• Try another videocassette to see if it plays back properly.</li> <li>• Press <b>CH/TRK ▲ / ▼</b> buttons up or down to adjust the picture.</li> <li>• Set INPUT MODE on the monitor to AUX IN, VIDEO or EXTERNAL.</li> <li>• Make sure the monitor is working properly.</li> <li>• If the problem occurs on more than one tape, try using a video head cleaner cassette.</li> </ul>
No broadcast picture.	<ul style="list-style-type: none"> <li>• Check all connections between VCR and the monitor.</li> <li>• Make sure the monitor is on.</li> </ul>
Streaks (noise) on a taped program.	<ul style="list-style-type: none"> <li>• Press <b>CH/TRK ▲ / ▼</b> buttons up or down to adjust the picture.</li> <li>• Check all connections.</li> <li>• View another videocassette to see if it plays back properly.</li> <li>• If the problem occurs on more than one tape, try using a video head cleaner cassette.</li> </ul> <p><b>Note:</b> Copy protection schemes can distort the picture; see your rental store operator.</p>
Streaks (noise) or jitter with the VCR in Still mode.	Press <b>CH/TRK ▲ / ▼</b> buttons up or down to adjust the picture.
Streaks (noise) on a taped program.	<ul style="list-style-type: none"> <li>• Check if the VCR is in Still mode.</li> <li>• Check if the cassette has been rewound</li> </ul>
The VCR motor continues to run even after <b>STOP</b> is pressed.	This is normal; the video heads run for five minutes even after a cassette has been stopped.

## Specifications

Format	VHS 1/2 inch (12.7mm)
Recording system	Rotary Double azimuth four-head helical scanning
Video heads	DA-4 rotary heads
Audio heads	Linear : 1 stationary Hi-Fi : 2 rotary
Control head	1 stationary
Erase	1 full track; 1 audio track
Record/play time	6 hours with T-120 in SLP mode
Antenna input/output terminals	UHF/VHF : 75 Ω F type connector
Signal-to-noise ratio	Linear : Better than 40 dB Hi-Fi : Better than 68 dB
Power source	12V DC
Power consumption	App. 12 Watts on
Dimensions	10.5"(W) x 3.64"(H) x 10.5"(D) (265mm x 94mm x 260mm)
Fuse	Internal 1.6 Amp GMA style
Weight	2.7lbs (4.5 kg)

Your VCR can receive 68 broadcast TV channels.

Type	Number	Channel List of Channels
On Air	12	VHF (Channels 2~13)
	56	UHF (Channels 14~69)