

EMC TEST REPORT



Project No.	LBE20113594	Issue No.	0
Applicant	Name of organization	Samsung Electronics Co., Ltd.	
	Address	416 Maetan 3-Dong, Yeongtong-Gu, Suwon-Si, Gyeonggi-Do 443-742 Korea	
	Date of application	July 07, 2011	
EUT	Type of device	Class B personal computers and peripherals	
	Equipment authorization	<input type="checkbox"/> Declaration of Conformity <input checked="" type="checkbox"/> Certification <input type="checkbox"/> Verification	
	FCC ID	A3LML2165W	
	Kind of product	MONO LASER PRINTER	
	Model No.	ML-2164W	
	Variant Model No.	ML-2165W, ML-2166W	
	Manufacturer	1) Samsung Electronics Co., Ltd. 259, Gongdan-Dong, Gumi-City, Gyeongsangbuk-Do, Korea 730-030 2) Samsung Electronics (Shandong) Digital Printing Co., Ltd. 264209, Samsung Road, Weihai Hi-Tech. IDZ, Shandong Province, P.R.China 3) Weihai Shin Heung Digital Electronics Co., Ltd. 98, Samsung Road, Weihai Hi-Tech. IDZ, Shandong Province, P.R.China 4) Intops : Intops (Weihai) Electronics Co., Ltd. Keji Road-268-1, Weihai Hi-Tech, Industries Development Zone , Shandong Province , CHINA	
Applied Standards	FCC Part 15, Subpart B / ANSI C63.4-2009		
Test Period	July 21, 2011 ~ July 24, 2011		
Issue date	September 08, 2011		
Test result : Complied			
The equipment under test has found to be compliant with the applied standards. (Refer to the attached test result for more detail.)			
Tested by : Sung Jin Sim 		Reviewed by : Tae Young, Jang 	
The test results in this report only apply to the tested sample. This report must not be reproduced, except in full, without written permission from CS & Environment center.			
			
416 Maetan 3-Dong, Yeongtong-Gu, Suwon-Si, Gyeonggi-Do, 443-742 Korea Tel: 82 31 277 7752, Fax: 82 31 277 7753			

Table of contents

1. Summary of test results	
1.1 Emission	- 3page
2. General Information	
2.1 Test facility	- 4 page
3. Test configuration	
3.1 Test configuration	- 4 page
3.2 EUT operating mode(s)	- 6 page
3.3 Details of Sampling	- 6 page
3.4 Clock Frequencies	- 6 page
3.5 EUT Description	- 7 page
3.6 Test configuration and condition	- 8 page
3.7 Measurement uncertainty	- 8 page
4. Result of individual tests	
4.1 Conducted disturbance	- 9 page
4.2 Radiated disturbance	- 15 page
Appendix – EUT photography	- 24 page

1. Summary of test results

1.1 Emission

The EUT has been tested according to the following specifications:

Applied	Test type	Applied standard	Result
<input checked="" type="checkbox"/>	Conducted Disturbance (Mains Port)	FCC Part 15 Subpart B / ANSI C63.4-2009	Complied
<input checked="" type="checkbox"/>	Radiated Disturbance		Complied

2. General Information

2.1 Test facility

The CS & Environment center is located on Samsung Electronics Co., Ltd. at 416 Maetan 3-Dong, Yeongtong-Gu, Suwon-Si, Gyeonggi-Do, South Korea.

All testing are performed in Semi-anechoic chambers conforming to the site attenuation Characteristics defined by ANSI C63.4, CISPR 22, 16-1 and 16-2. and Shielded rooms.

The CS & Environment center is operated as testing laboratory in accordance with the requirements of ISO/IEC 17025:2005.

3. Test Setup configuration

3.1 Test configuration

3.1.1 Test Peripherals

The cables used for these peripherals are either permanently attached by the peripheral manufacturer or coupled with an assigned cable as defined below.

The following is a listing of the EUT and peripherals utilized during the performance of EMC test:

Seq	Description	Model No.	Serial No.	Manufacturer	Fcc ID / DoC
A	Mono laser printer	ML-2164W	-	SAMSUNG	EUT
B	Laptop PC	NP-R55	232V93BP200005N	SAMSUNG	DoC
C	Adapter	ADP-60ZH D AD-6019R	CNBA4400242ABZ0408J0857	Delta electronics	DoC
D	USB mouse	SMH-210U	M2UWTAKQA6997V	Monterey international	DoC
E	Head set	COV903	-	COSY	-

3.1.2 Test cables

No.	Connected cable	Length [m]	Shielded [Y/N]	Note
1	Power	1.8	No	For EUT
2	Power	1.0	No	For laptop PC
3	USB	1.5	Yes	From laptop PC to EUT
4	USB	1.8	Yes	From laptop PC to Mouse
5	Audio	2.0	No	From laptop PC to Headphones

3.1.3 Test arrangement

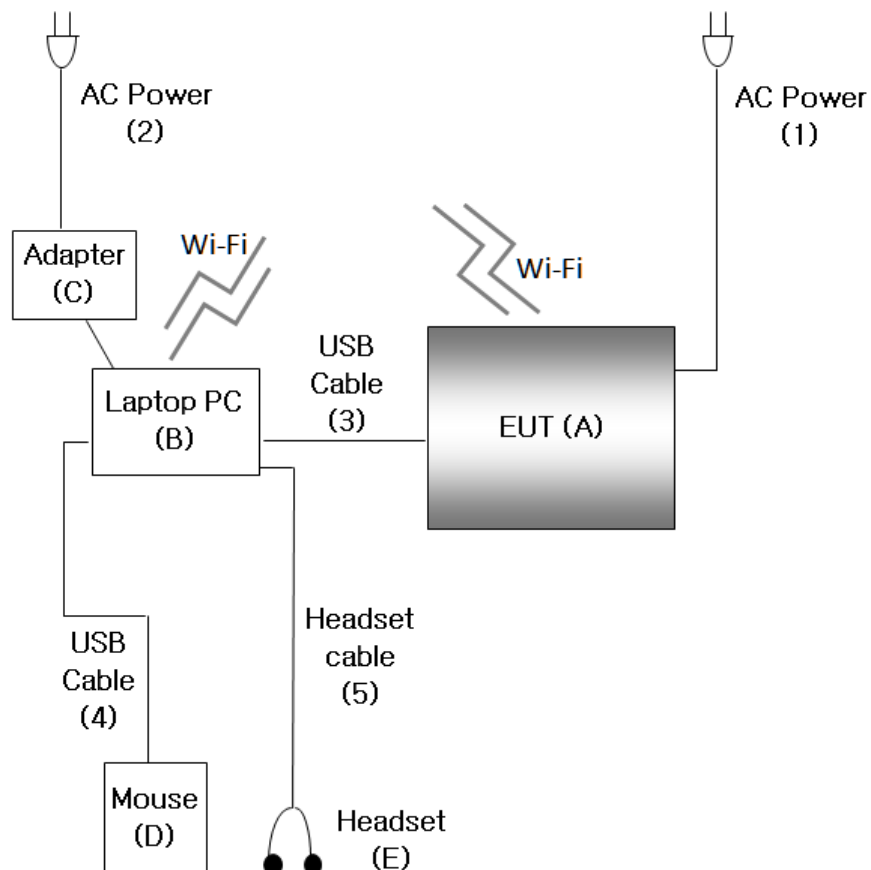

3.2 EUT operating mode

To achieve compliance applied standard specification, the following mode(s) were made during compliance testing:

Operating Mode 1	Standby
Operating Mode 2	Wireless LAN Printing

3.3 Details of Sampling

Customer selected, single unit.

3.4 Clock Frequencies

Kind of Clocks	Frequency[MHz]	Kind of Clocks	Frequency[MHz]
Main source clock	12	CPU internal clock	300
Video clock	23.571	USB device clock	12

3.5 EUT Description

The following features describe EUT represented by this report:

Item	Specification and Description
Processor	TEMUJIN(300 MHz)
Standard System memory	Embedded SDRAM core of ESMTwith 32 MB size
Resolution	True 1 200 x 1 200 dpi
Paper Handling	150-sheet Cassette @ 80 g/m ² , 10-sheet @ Special Paper
Power Rating	110 VAC~127 VAC, 5A, 50 Hz / 60 Hz
Power Consumption	Power save mode : 1.2 Watts Printing mode: MAX 310 Watts
Printer Language	SPL
PC Interfaces	USB 2.0, 802.11 b/g/n
OS compatibility	Windows 7/2000/XP(32/64bit)/2003(32/64bit)/Vista(32/64bit)/2008 Server(32/64bit) Various Linux OS: RedHat Enterprise Linux WS 4, 5 (32/64 bit) Fedora 5, 6, 7, 8, 9, 10, 11, 12, 13 (32/64 bit), SuSE Linux 10.1 (32 bit) OpenSuSE 10.2, 10.3, 11.0, 11.1, 11.2 (32/64 bit) Mandriva 2007, 2008, 2009, 2009.1, 2010 (32/64 bit) Ubuntu 6.06, 6.10, 7.04, 7.10, 8.04, 8.10, 9.04, 9.10, 10.04 (32/64 bit) SuSE Linux Enterprise Desktop 10, 11 (32/64 bit), Debian 4.0, 5.0 (32/64 bit) Mac OS 10.4~10.6, Sun Solaris 9,10 (x86, SPARC) HP-UX 11.0, 11i v1, 11i v2, 11i v3 (PA-RISC, Itanium), IBM AIX 5.1, 5.2, 5.3, 5.4
Modes of Operation	USB Printing, Wireless LAN Printing
Intended Class for Emissions	Class B

3.6 Test configuration and condition

The system was configured for testing in typical fashion use. Cables were attached to each of the available I/O Ports. Where applicable, peripherals were attached to the I/O cables. The mode of operation utilized for testing was selected to best simulate typical EUT use.

The EUT was measured all testing with toner cartridge.

Power source for the EUT operating was supplied by CVCF made by the Voltech Corp.

- Test Voltage : AC 120 V, 60 Hz

3.7 Measurement uncertainty

Where relevant, the following measurement uncertainty levels have been estimated for tests performed on the apparatus: (According to CISPR 16-4 and UKAS Lab 34.)

3.7.1 Emission

Test type		Measurement uncertainty (C.L. 95 %, k = 2)
Conducted disturbance	Main terminal	3.30 dB
Radiated Disturbance (Below 1 GHz)	Horizontal	5.26 dB
	Vertical	5.27 dB
Radiated Disturbance (Above 1 GHz)	Horizontal	3.40 dB
	Vertical	3.12 dB

4. Results of individual test

4.1 Conducted disturbance

Both conducted lines are measured in Quasi-Peak and Average mode, including the worst-case data points for each tested configuration. The EUT measured in accordance with the methods described in standards.

Limits for conducted disturbance at the mains ports of class B ITE

Frequency range Limits MHz	Resolution Bandwidth	Limits dB μ V	
		Quasi-peak	Average
0.15 to 0.50	9 kHz	66 to 56	56 to 46
0.50 to 5	9 kHz	56	46
5 to 30	9 kHz	60	50
NOTE 1 The lower limit shall apply at the transition frequency			
NOTE 2 The limit decreases linearly with the logarithm of the frequency in the range 0.15 MHz to 0.50 MHz.			

4.1.1 Test instrumentation

Test instrumentation	Model name	Manufacturer	Serial or Firmware (No./Ver.)	Calibration	
				Date	Interval (Month)
Measuring receiver	ESIB26	R&S	100147	2011-04-07	12
Artificial mains network	ENV216	R&S	100117	2010-11-16	12
Artificial mains network	ESH3-Z5	R&S	100262	2010-09-27	12
Test software	EMC32	R&S	Ver 5.20.1	N/A	N/A

4.1.2 Temperature and humidity condition

Test date	July 21, 2011	Test engineer	Sung Jin Sim		
Climate condition	Ambient temperature	23.6 °C	Relative humidity	35 %	
	Atmospheric pressure	100.5 kPa			
Test place	Shielded Room #1				

4.1.3 Photograph of Test Setup

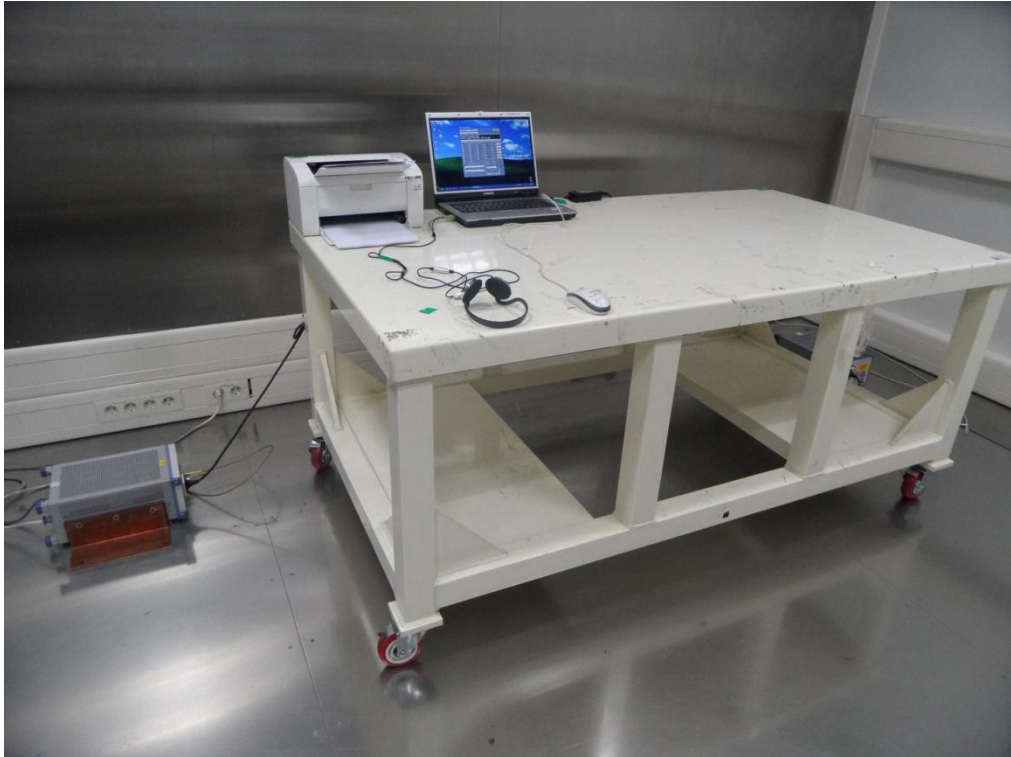

Front

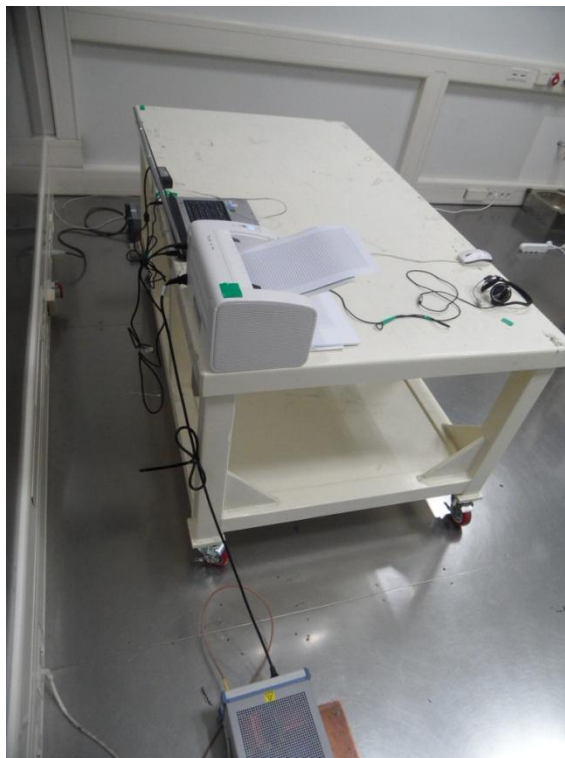

Rear

4.1.4 Test results (mains port)

Operating Mode 1 : Standby Mode

Hardware Setup: Voltage with ENV 2-Line-LISN - [EMI conducted]

Subrange 1
 Frequency Range: 150 kHz – 30 MHz
 Receiver: ESIB 26
 Transducer: ENV216 / Receiver-2-Line-LISN ENV216

Scan Setup: ITE_B_ENV 2-Line-LISN fin [EMI conducted]

Hardware Setup: Voltage with ENV 2-Line-LISN
 Level Unit: dB μ V

Subrange	Detectors	IF Bandwidth	Meas. Time	Receiver
150 kHz – 30 MHz	Quasi Peak; Average	9 kHz	15 s	ESIB 26

Test Graph

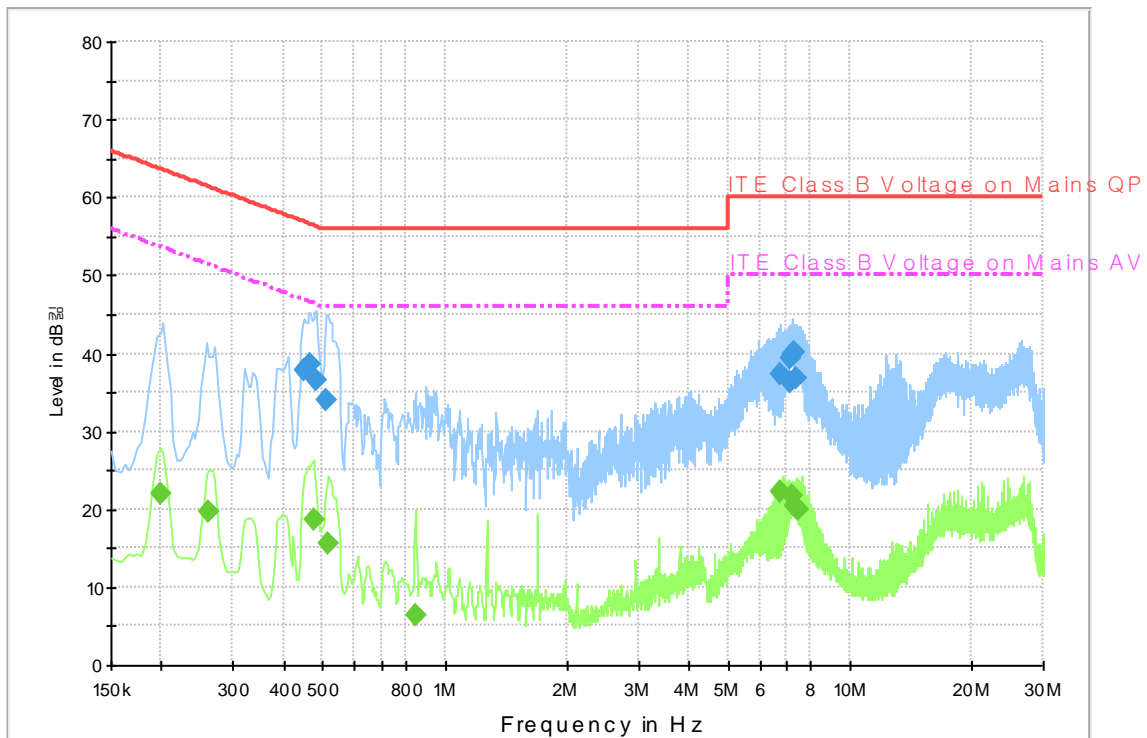

Note) Two graphs measured for both Live(L1) and Neutral(N) of the LISN are combined into one graph.

Test Results (Quasi-Peak and Average)

Quasi-peak final measurement results table

Frequency (MHz)	Quasi-Peak (dB μ V)	Line	Corr. (dB)	Margin (dB)	Limit (dB μ V)
0.450	37.7	N	10.1	19.2	56.9
0.466	38.6	N	10.1	18.0	56.6
0.482	36.5	N	10.1	19.8	56.3
0.510	34.0	N	10.1	22.0	56.0
6.764	37.3	N	9.8	22.7	60.0
7.104	36.2	N	9.8	23.8	60.0
7.112	39.4	N	9.8	20.6	60.0
7.180	39.8	N	9.8	20.2	60.0
7.316	40.1	N	9.8	19.9	60.0
7.376	36.7	N	9.8	23.3	60.0

Average final measurement results table

Frequency (MHz)	Average (dB μ V)	Line	Corr. (dB)	Margin (dB)	Limit (dB μ V)
0.198	21.9	N	9.9	31.8	53.7
0.262	19.7	N	9.9	31.7	51.4
0.474	18.6	N	10.1	27.8	46.4
0.518	15.5	N	10.1	30.5	46.0
0.846	6.3	N	9.9	39.7	46.0
6.764	22.4	N	9.8	27.6	50.0
7.180	21.8	N	9.8	28.2	50.0
7.312	20.5	N	9.8	29.5	50.0
7.380	20.3	N	9.8	29.7	50.0
7.448	20.0	N	9.8	30.0	50.0

Note) Level (Quasi-Peak and/or Average) = Meter Reading (Quasi-Peak and/or Average) + Factor (LISN Insertion Loss + Cable Loss)

Margin = Limit – Level (Quasi-Peak and/or Average)

Operating Mode 2 : Wireless LAN Printing

Hardware Setup: Voltage with ENV 2-Line-LISN - [EMI conducted]

Subrange 1
 Frequency Range: 150 kHz – 30 MHz
 Receiver: ESIB 26
 Transducer: ENV216 / Receiver-2-Line-LISN ENV216

Scan Setup: ITE_B_ENV 2-Line-LISN fin [EMI conducted]

Hardware Setup: Voltage with ENV 2-Line-LISN
 Level Unit: dB μ V

Subrange	Detectors	IF Bandwidth	Meas. Time	Receiver
150 kHz – 30 MHz	Quasi Peak; Average	9 kHz	15 s	ESIB 26

Test Graph

EN 55022_LISN

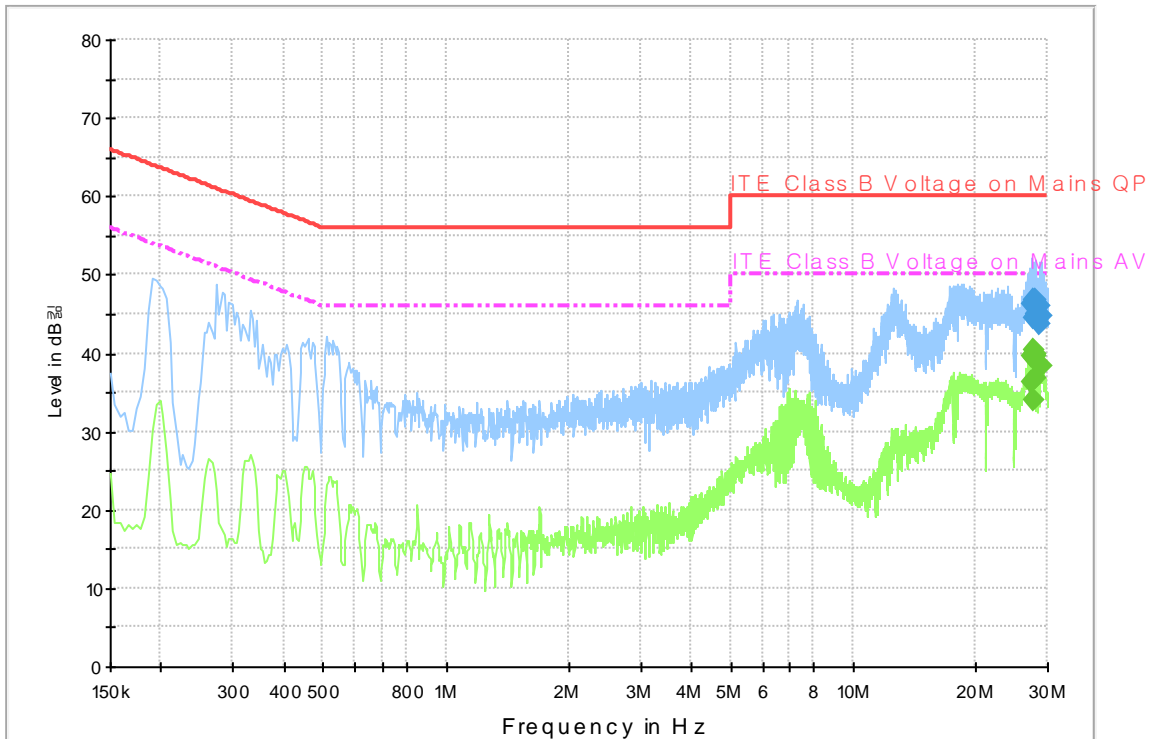

Note) Two graphs measured for both Live(L1) and Neutral(N) of the LISN are combined into one graph.

Test Results (Quasi-Peak and Average)

Quasi-peak final measurement results table

Frequency (MHz)	Quasi-Peak (dB μ V)	Line	Corr. (dB)	Margin (dB)	Limit (dB μ V)
27.540	46.2	N	10.2	13.8	60.0
27.620	44.5	L1	10.2	15.5	60.0
27.772	46.7	N	10.2	13.3	60.0
27.872	45.0	L1	10.2	15.0	60.0
27.948	46.4	N	10.2	13.6	60.0
27.964	46.8	L1	10.2	13.2	60.0
28.040	44.8	N	10.2	15.2	60.0
28.680	43.7	N	10.3	16.3	60.0
28.728	46.0	N	10.3	14.0	60.0
28.900	44.8	L1	10.3	15.2	60.0

Average final measurement results table

Frequency (MHz)	Average (dB μ V)	Line	Corr. (dB)	Margin (dB)	Limit (dB μ V)
27.532	36.2	N	10.2	13.8	50.0
27.540	39.7	N	10.2	10.3	50.0
27.572	39.4	N	10.2	10.6	50.0
27.620	33.9	L1	10.2	16.1	50.0
27.660	40.5	N	10.2	9.5	50.0
27.776	39.7	N	10.2	10.3	50.0
27.872	39.8	L1	10.2	10.2	50.0
27.948	36.7	N	10.2	13.3	50.0
27.964	39.6	L1	10.2	10.4	50.0
28.900	38.3	L1	10.3	11.7	50.0

Note) Level (Quasi-Peak and/or Average) = Meter Reading (Quasi-Peak and/or Average) + Factor (LISN Insertion Loss + Cable Loss)

Margin = Limit – Level (Quasi-Peak and/or Average)

4.2 Radiated disturbance

Of those disturbances above ($L - 20$ dB), where L is the limit level in logarithmic units, record at least the disturbance levels and the frequencies of the six highest disturbances.

The following data lists the significant emission frequencies, measured levels, correction factors (for antenna and cables), orientation of table, polarization and height of antenna, the corrected reading, the limit, and the amount of margin. All measurements were taken utilizing quasi-peak detection unless stated otherwise.

Measurements were performed at an antenna to EUT distance of 10 m and elevated between 1 m and 4 m.

Both vertical and horizontal antenna polarizations were measured.

Limits for radiated disturbance of ITE at a measuring distance of 10 m

Frequency range Limits MHz	Resolution Bandwidth	Quasi-peak Limits dB μ V/m
		Class B
30 to 230	120 kHz	30
230 to 1000	120 kHz	37
NOTE 1 The lower limit shall apply at the transition frequency		
NOTE 2 Additional provisions may be required for cases where interference occurs.		

Peak measurements were made over the changeable frequency range 1 GHz to 40 GHz or 5th in accordance with internal maximum operating frequency at a measurement distance of 3 m for the following antenna and turntable arrangements:

Antenna Height (cm)	Antenna Polarisation	Turntable position (degrees)
100 ~ 400	Horizontal, Vertical	Continuous

Limits for above 1GHz radiated disturbance of ITE at a measuring distance of 3 m

Class	Limits - dB(μ V/m)	
	Peak	Average
B	74	54
Average limit 500, $20 \log 500 = 53.979 \text{ dB} \approx 54 \text{ dB}$		

Measurements within 20 dB of the limit were then maximized by adjusting turntable position. Final measurements were made using a average detector.

Results checked manually; and points close to the limit line were re-measured.

4.2.1 Test instrumentation

Test instrumentation	Model name	Manufacturer	Serial or Firmware (No./Ver.)	Calibration	
				Date	Interval (Month)
Bi-con Antenna	CBL6112D	Schaffner	22602	2010-04-21	24
Horn Antenna	HF907	R&S	100016	2011-06-15	24
EMI Receiver	ESIB-26	R&S	100147	2011-04-07	12
Amplifier	310N	Agilent	185861	2011-04-07	12
Preamplifier	SCU_F018	R&S	10001	2011-04-10	12
Antenna Mast	MA4000	INN CO	-	N/A	N/A
Mast Controller	CO2000	INN CO	-	N/A	N/A
Test software	EP5/RE	TOYO	VER 3.1.20	N/A	N/A
RF Selector	NS4900	TOYO	-	N/A	N/A

4.2.2 Temperature and humidity condition

Test date	July 24, 2011	Test engineer	Sung Jin Sim	
Climate condition	Ambient temperature	24.1 °C	Relative humidity	36 %
	Atmospheric pressure	100.9 kPa		
Test place	10 m Semi-Anechoic Chamber			

4.2.3 Photograph of Test Setup



Front (Below 1GHz)

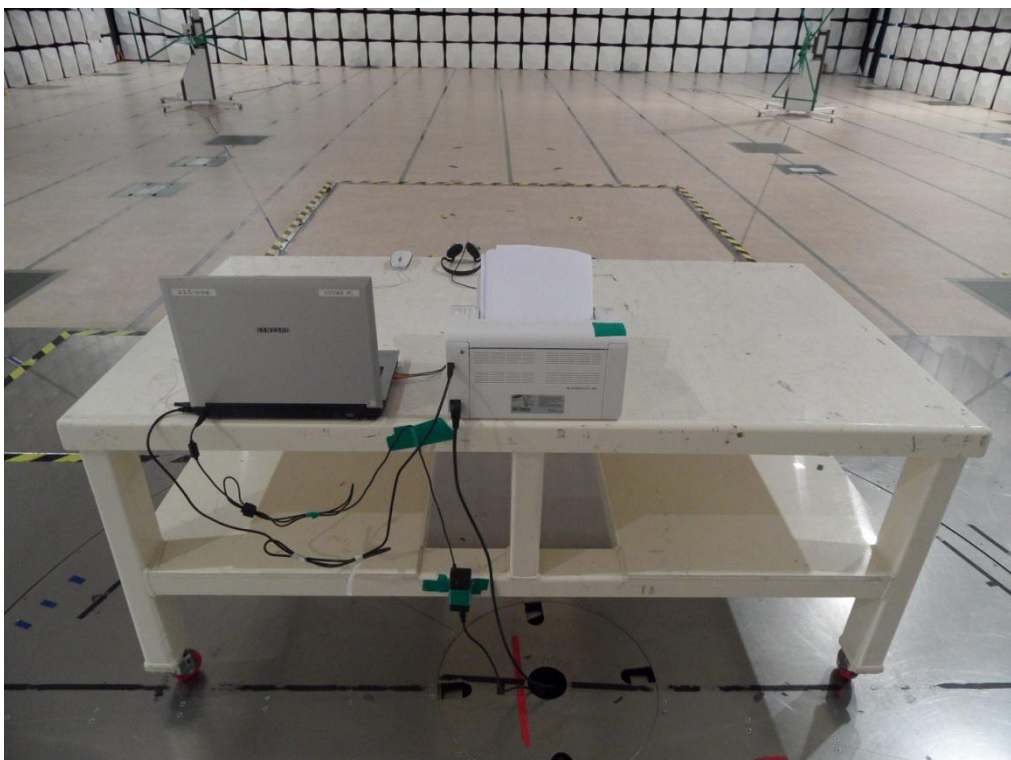

Rear (Below 1GHz)



Front (above 1GHz)

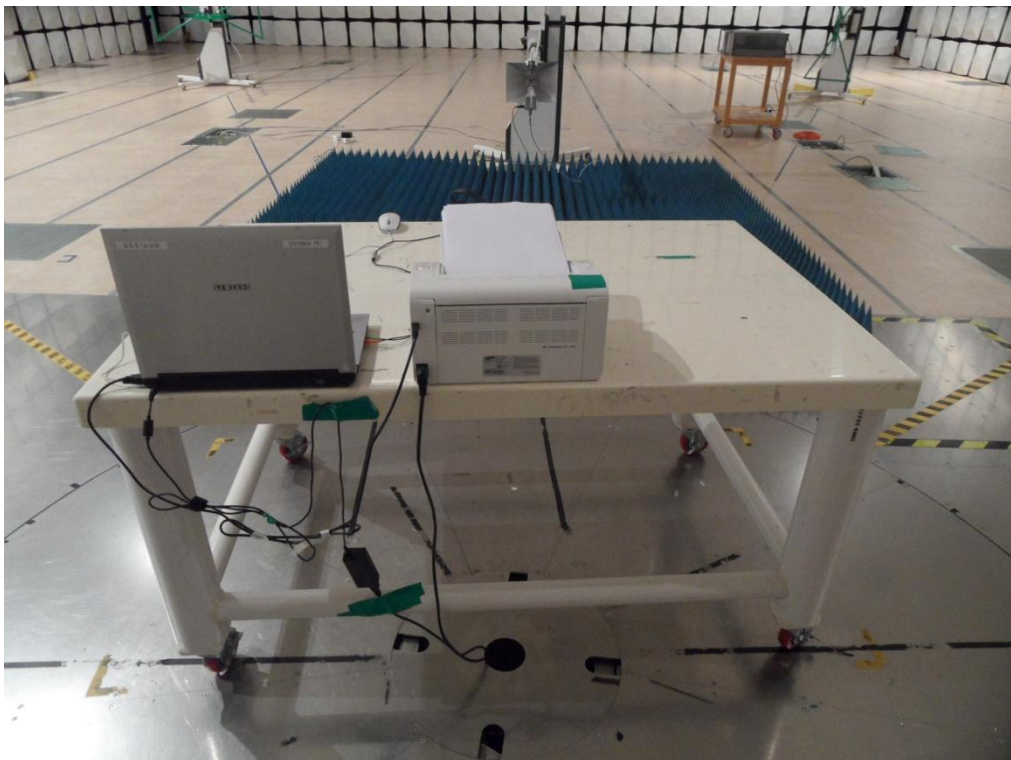

Rear (above 1GHz)

4.2.4 Test results

4.2.4.1 30 MHz to 1GHz test results

Operating Mode 1 : Standby

Test Graph and Results

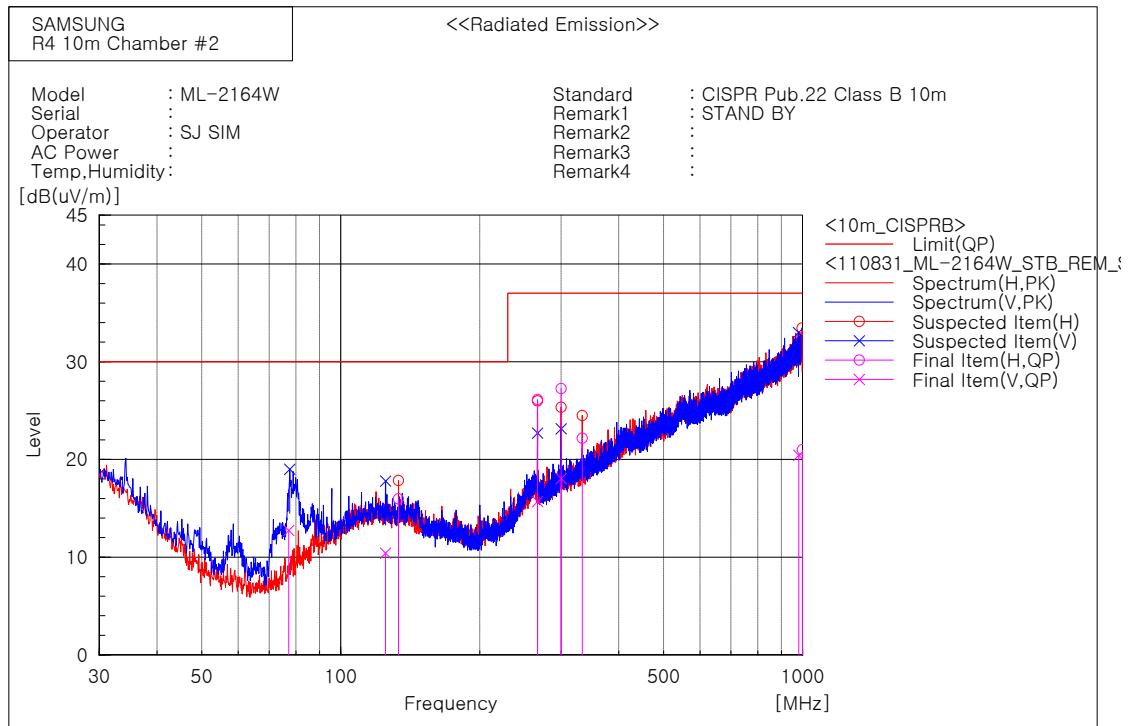

Frequency [MHz]	Pol.	Reading QP [dB(µV)]	Factor [dB(1/m)]	Level QP [dB(µV /m)]	Limit [dB(µV /m)]	Margin QP [dB]	Height [cm]	Angle [deg]
77.156	V	36.2	-23.5	12.7	30	17.3	151	358.2
124.976	V	27.4	-17.0	10.4	30	19.6	105	244.2
133.331	H	33.1	-17.1	16.0	30	14.0	352	356.0
266.700	V	30.2	-14.5	15.7	37	21.3	282	299.0
266.722	H	40.9	-14.8	26.1	37	10.9	390	322.1
299.990	H	41.0	-13.8	27.2	37	9.8	400	355.3
299.996	V	32.1	-14.1	18.0	37	19.0	100	57.4
333.352	H	35.0	-12.8	22.2	37	14.8	255	350.1
981.586	V	20.7	-0.3	20.4	37	16.6	215	353.9
998.910	H	20.7	0.3	21.0	37	16.0	400	332.5

Note) Receiving antenna polarization : Horizontal and/or Vertical
 Test Distance : 10 m, Antenna Height : 1 m to 4 m
 Level QP (Quasi-Peak) = Reading QP + Factor (Antenna Factor + Cable Loss - Amp. Gain)
 Margin QP (Quasi-Peak) = Limit - Level QP



Operating Mode 2 : Wireless LAN Printing

Test Graph and Results

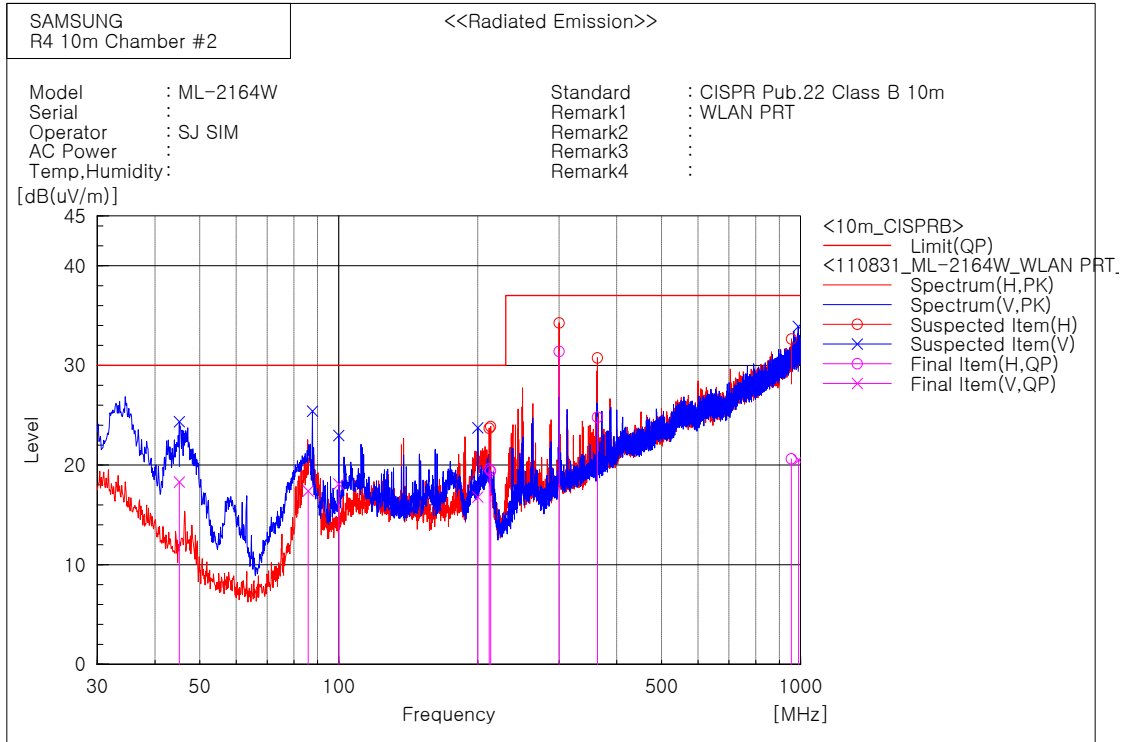

Frequency [MHz]	Pol.	Reading QP [dB(μV)]	Factor [dB(1/m)]	Level QP [dB(μV /m)]	Limit [dB(μV /m)]	Margin QP [dB]	Height [cm]	Angle [deg]
45.156	V	39.1	-20.8	18.3	30	11.7	300	109.2
85.859	V	38.8	-21.4	17.4	30	12.6	333	0.5
99.961	V	36.9	-18.8	18.1	30	11.9	100	189.6
199.993	V	36.8	-20.0	16.8	30	13.2	100	238.8
211.754	H	38.3	-18.7	19.6	30	10.4	400	320.7
213.209	H	38.1	-18.7	19.4	30	10.6	298	327.9
300.036	H	45.2	-13.8	31.4	37	5.6	236	1.9
363.195	H	36.1	-11.3	24.8	37	12.2	208	295.7
954.878	H	21.1	-0.5	20.6	37	16.4	388	167.6
989.885	V	20.6	-0.1	20.5	37	16.5	388	198.7

Note) Receiving antenna polarization : Horizontal and/or Vertical
 Test Distance : 10 m, Antenna Height : 1 m to 4 m
 Level QP (Quasi-Peak) = Reading QP + Factor (Antenna Factor + Cable Loss - Amp. Gain)
 Margin QP (Quasi-Peak) = Limit - Level QP



4.2.4.2 1 GHz to 2 GHz test results

Operating Mode 1 : Standby

Test Results

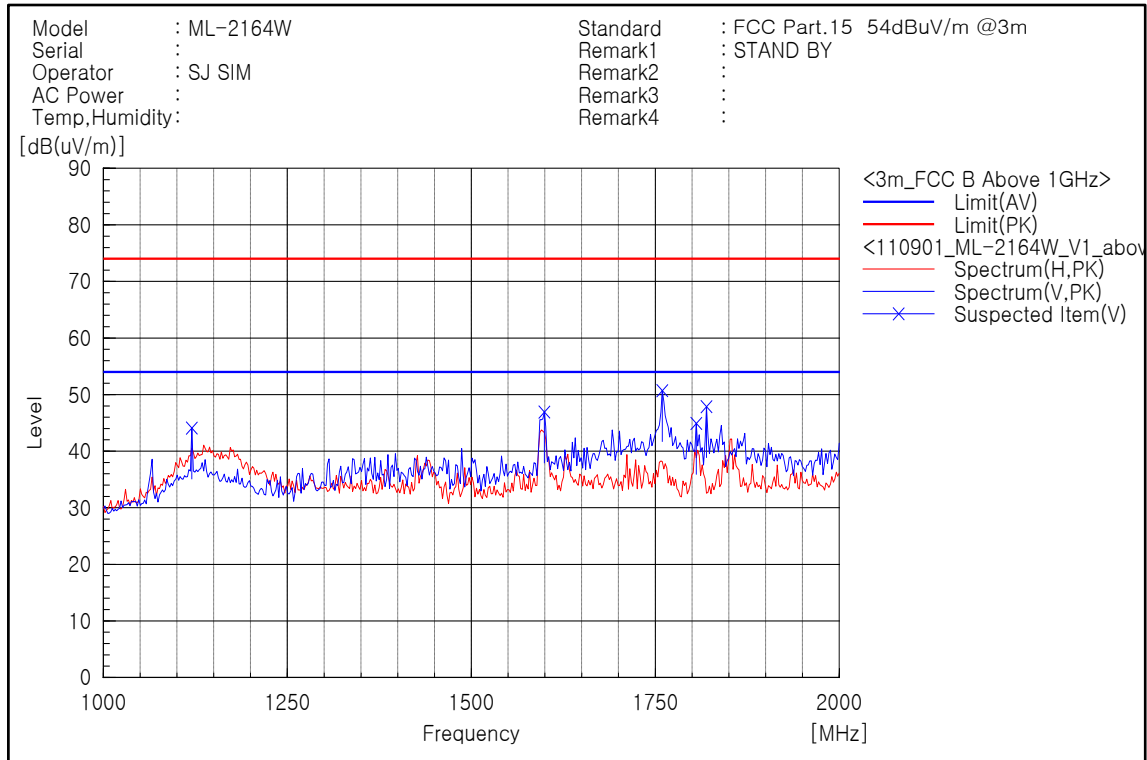

Peak Measurement

Frequency [MHz]	POL	Reading PK [dB(uV)]	Factor [dB(1/m)]	Level PK [dB(uV/m)]	Limit [dB(uV/m)]	Margin PK [dB]	Height [cm]	Angle [deg]
1120.241	V	57.4	-13.3	44.1	74	29.9	108	356.8
1599.198	V	57.8	-10.9	46.9	74	27.1	108	12.1
1759.519	V	61.1	-10.4	50.7	74	23.3	108	355.8
1805.611	V	55.0	-10.1	44.9	74	29.1	108	14.4
1819.639	V	57.9	-10.0	47.9	74	26.1	108	14.4

Note1) Representative operating modes were selected by customer and any emissions that do NOT exceed Average limit were not tested with average detector mode.

Note2) Receiving antenna polarization : Horizontal and Vertical

Level PK (Peak) = Reading PK (Peak) + Factor (Antenna Factor + Cable Loss - Amp. Gain)

Level AV (Average) = Reading AV (Average) + Factor (Antenna Factor + Cable Loss - Amp. Gain)

Margin PK (Peak) = Limit – Level PK (Peak)

Margin AV (Average) = Limit – Level AV (Average)

Operating Mode 2 : Wireless LAN Printing

Test Results

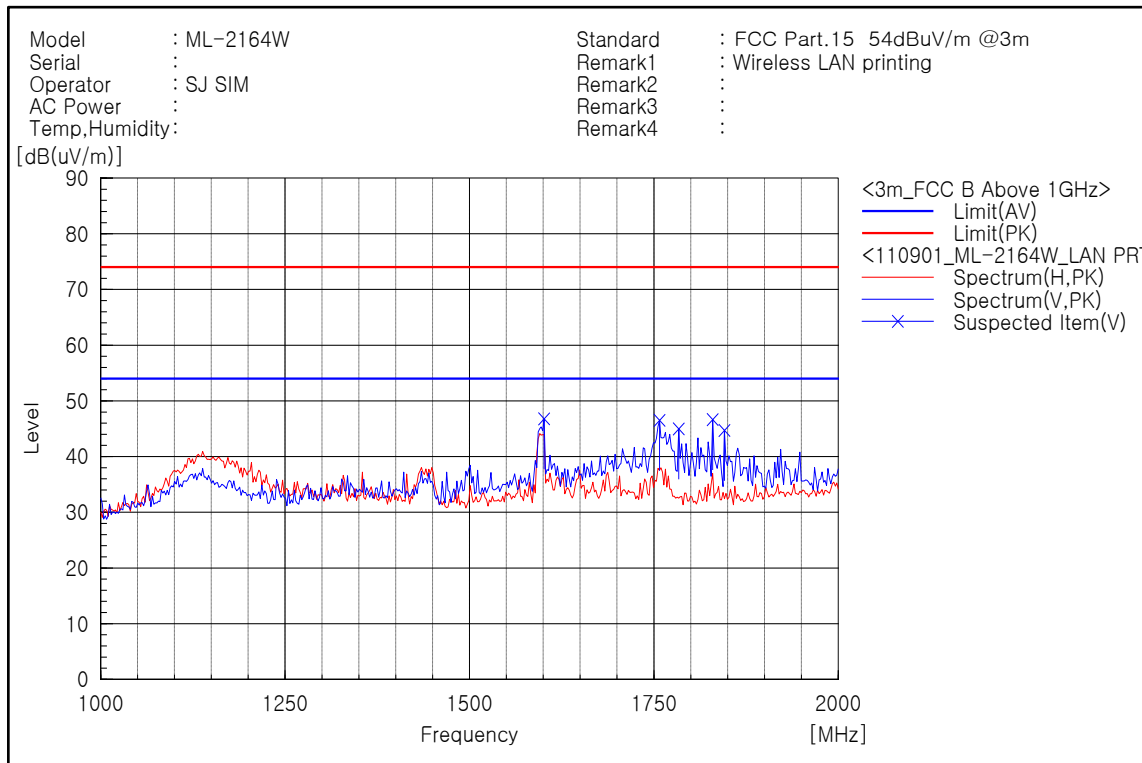

Peak Measurement

Frequency [MHz]	POL	Reading PK [dB(uV)]	Factor [dB(1/m)]	Level PK [dB(uV/m)]	Limit [dB(uV/m)]	Margin PK [dB]	Height [cm]	Angle [deg]
1601.202	V	57.7	-10.9	46.8	74	27.2	108	31.5
1757.515	V	56.9	-10.4	46.5	74	27.5	108	356.3
1783.567	V	55.3	-10.3	45.0	74	29.0	108	337.0
1829.659	V	56.5	-9.9	46.6	74	27.4	108	337.0
1845.691	V	54.5	-9.8	44.7	74	29.3	108	337.0

Note1) Representative operating modes were selected by customer and any emissions that do NOT exceed Average limit were not tested with average detector mode.

Note2) Receiving antenna polarization : Horizontal and Vertical

Level PK (Peak) = Reading PK (Peak) + Factor (Antenna Factor + Cable Loss - Amp. Gain)

Level AV (Average) = Reading AV (Average) + Factor (Antenna Factor + Cable Loss - Amp. Gain)

Margin PK (Peak) = Limit – Level PK (Peak)

Margin AV (Average) = Limit – Level AV (Average)



Front inside View

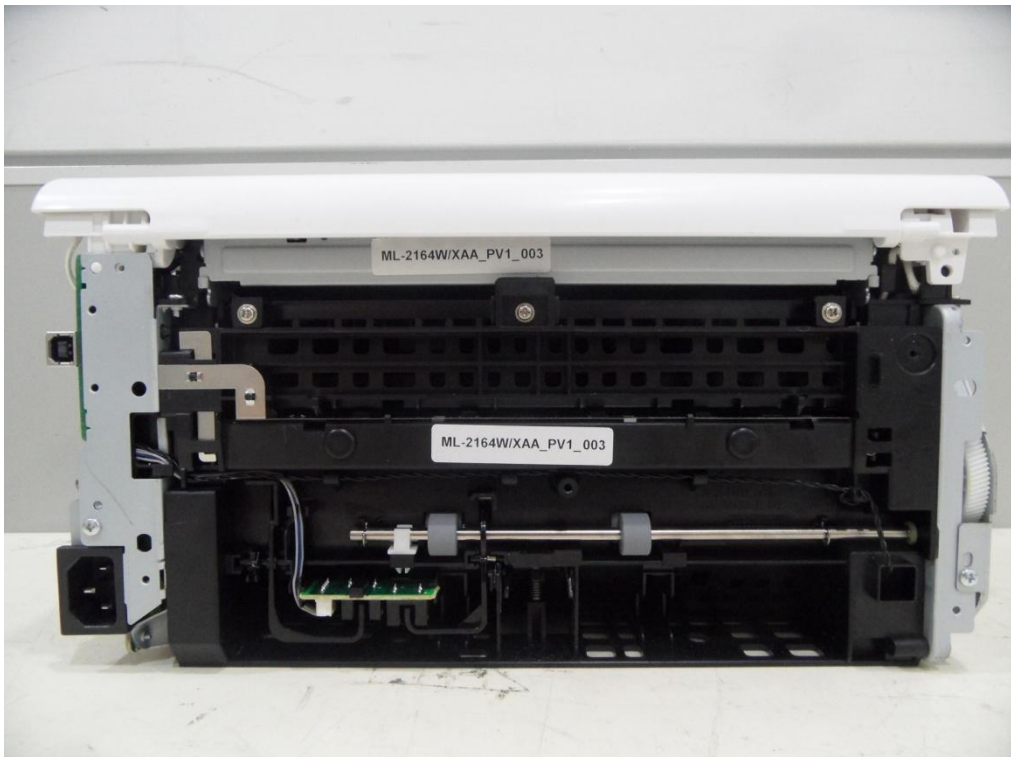

Rear inside View

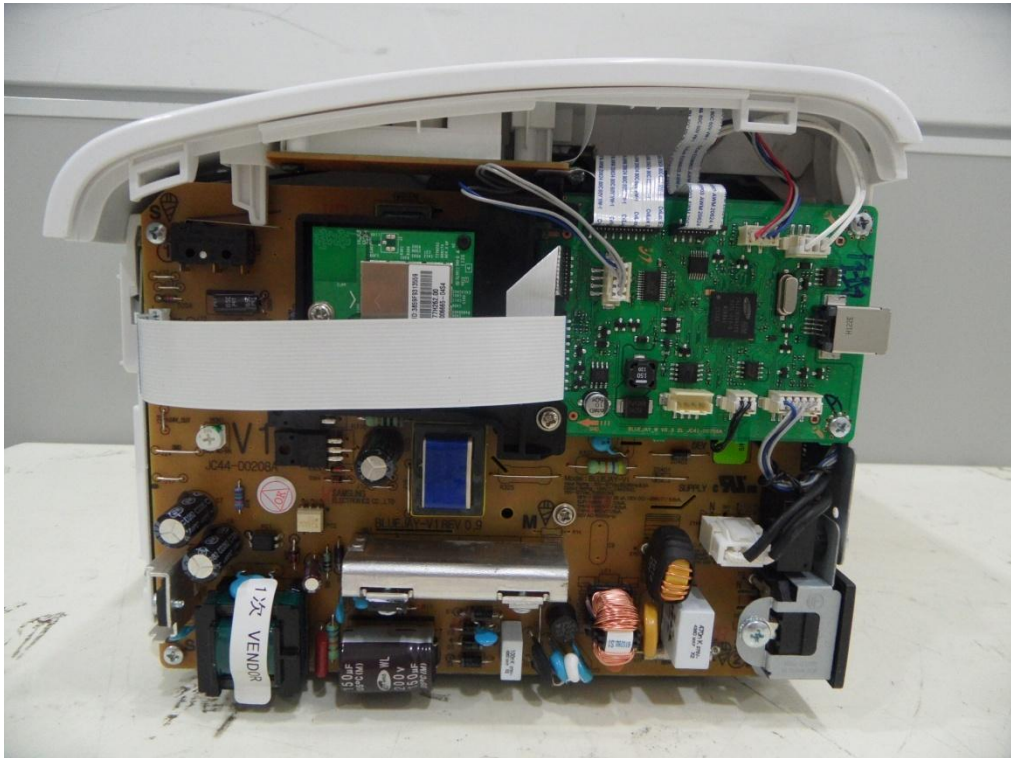

Left-inside View

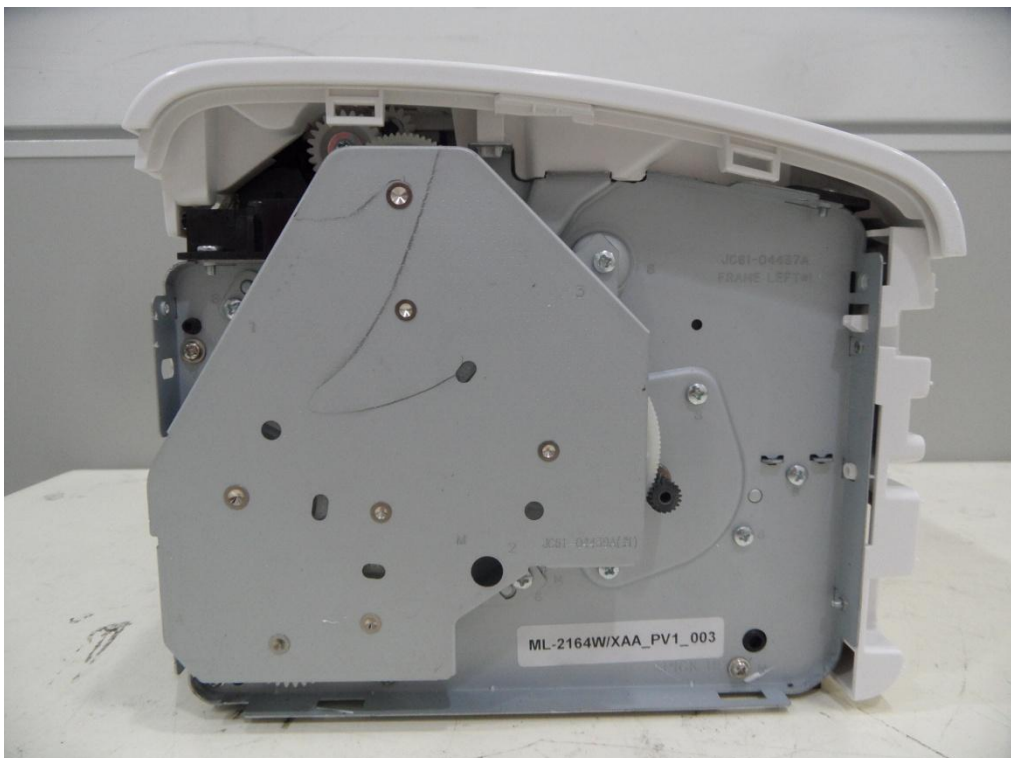



Right-inside View

Project No. : LBE20113594



MONO LASER PRINTER : ML-2164W

 Samsung Electronics Co., Ltd. Suwon, Korea, 443-742 Place: M264	Model: ML-2165W	FCC ID : A3LML2165W
	Volts: AC 110-127V	Contains FCC ID : MCLT77H262
	Hertz: 50/60 Hz	This device complies with part 15 of the FCC Rules.
	Amps: 5.0A	Operation is subject to the following two conditions:
	Manufactured:	i) This device may not cause harmful interference, and
		ii) This device must accept any interference received, including interference that may cause undesired operation.
		This Class B digital apparatus complies with Canadian ICES-003
	3UU7	Cet appareil numérique de la classe B est
	E337632	Conforme à la norme NMB-003 du Canada.
	I.T.E.	This product complies with 21 CFR Chapter 1, subchapter J.
		Contains IC : 2878D-T77H62
Serial No.:		Made in China Fabriqué en Chine REV.00

Label