



# Nemko Korea Co., Ltd.

155 & 159, Osan-Ro, Mohyeon-Myeon, Cheoin-Gu, Yongin-Si, Gyeonggi-Do 449-852 KOREA, REPUBLIC OF

TEL:+82 31 330-1700 FAX:+82 31 322 2332

## FCC and IC EVALUATION REPORT FOR CERTIFICATION

**Applicant :**

**Samsung Electronics Co., Ltd.**  
**129, Samsung-ro, Yeongtong-gu,**  
**Suwon-si, Gyeonggi-do, Korea.**  
**(Post code : 443-742)**  
**Attn. : Mr. Jaywoo. Lee**

**Dates of Issue : January 7, 2013**  
**Test Report No. : NK-12-R-235-2**  
**Test Site : Nemko Korea Co., Ltd.**

**FCC ID**  
**IC**

**Brand Name**

**Contact Person**

<p><b>A3LWIDT30Q</b> <b>649E-WIDT30Q</b></p> <p><b>SAMSUNG</b></p> <p><b>Samsung Electronics Co., Ltd.</b> <b>129, Samsung-ro, Yeongtong-gu,</b> <b>Suwon-si, Gyeonggi-do, Korea, 443-742.</b> <b>Mr. Jaywoo. Lee</b> <b>Telephone No. : +82-31-277-2569</b></p>
--

Applied Standard: FCC 47 CFR Part 15.407 and IC RSS-210 Issue 8  
Classification: Unlicensed National Information Infrastructure (UNII)  
EUT Type: WiFi module

The device bearing the brand name and model specified above has been shown to comply with the applicable technical standards as indicated in the measurement report and was tested in accordance with the measurement procedures specified in ANSI C63.4-2003, ANSI C63.10-2009. The client should not use it to claim product endorsement by TAF or any government agencies. The test results in the report only apply to the tested sample.

I attest to the accuracy of data and all measurements reported herein were performed by me or were made under my supervision and are correct to the best of my knowledge and belief. I assume full responsibility for the completeness of these measurements and vouch for the qualifications of all persons taking them.

  
Jan. 7, 2013  
Tested By : Jin-ha Ko  
Engineer

  
Jan. 7, 2013  
Reviewed By : Deokha Ryu  
Technical Manager

# TABLE OF CONTENTS

---

<b>1. Scope</b>	<b>4</b>
<b>2. Introduction (Site Description)</b>	<b>5</b>
2.1 Test facility	5
2.2 Accreditation and listing	6
<b>3. Test Conditions &amp; EUT Information</b>	<b>7</b>
3.1 Operation During Test	7
3.1.1 Table of test channel	7
3.1.2 Table of test modes	8
3.2 Support Equipment	9
3.3 Setup Drawing	9
3.4 EUT Information	10
<b>4. Summary of Test Results</b>	<b>12</b>
<b>5. Recommendation / Conclusion</b>	<b>13</b>
<b>6. Antenna Requirements</b>	<b>13</b>
<b>7. Description of Test</b>	<b>14</b>
7.1 Conducted Emissions	14
7.2 Radiated Emissions	15
7.3 26 dB Bandwidth and 99% Occupied Bandwidth	16
7.4 Maximum Peak Output Power	17
7.5 Peak Power Spectral Density	18
7.6 Peak Excursion Measurement	19
7.7 Frequency Stability	20
<b>8. Test Data</b>	<b>21</b>
8.1 Conducted Emissions	22
8.2 Radiated Emissions	24
8.3 26 dB Modulated Bandwidth and 99% Occupied Bandwidth	25
8.3.1 26 dB Modulated Bandwidth and 99% Occupied Bandwidth – Band I	25
8.3.2 26 dB Modulated Bandwidth and 99% Occupied Bandwidth – Band II	34

8.3.1 26 dB Modulated Bandwidth and 99% Occupied Bandwidth – Band III	43
8.4 Maximum Peak Output Power	53
8.4.1 Maximum Peak Output Power – Band I	53
8.4.2 Maximum Peak Output Power – Band II	63
8.4.3 Maximum Peak Output Power – Band III	73
8.5 Power Spectral Density	84
8.5.1 Power Spectral Density – Band I	84
8.5.2 Power Spectral Density – Band II	93
8.5.3 Power Spectral Density – Band III	102
8.6 Peak Excursion	112
8.7 Radiated Spurious Emissions	116
8.7.1 Radiated Spurious Emissions – Band I	116
8.7.2 Radiated Spurious Emissions – Band II	120
8.7.3 Radiated Spurious Emissions – Band III	124
8.8 Radiated Band Edge	129
8.8.1 Radiated Band Edge – Band I and II	129
8.8.2 Radiated Band Edge – Band III	132
8.8 Frequency Stability	135
8.8.1 Frequency Stability – Band I	135
8.8.2 Frequency Stability – Band II	136
8.8.3 Frequency Stability – Band III	137
<b>9 Test Equipment</b>	<b>138</b>
<b>10 Accuracy of Measurement</b>	<b>139</b>
<b>Appendix A: Labelling Requirement</b>	<b>141</b>
<b>Appendix B: Photographs of Test Set-up</b>	<b>142</b>
<b>Appendix C: EUT Photographs</b>	<b>144</b>
<b>Appendix D: Maximum Permissible Exposure</b>	<b>153</b>

## 1. SCOPE

---

Measurement and determination of electromagnetic emissions (EME) of radio frequency devices including intentional and/or unintentional radiators for compliance with the technical rules and regulations of the Federal Communications Commission under FCC part 15.407 and IC RSS-210 Issue 8.

<b>Responsible Party :</b>	Samsung Electronics Co., Ltd.
<b>Contact Person :</b>	Mr. Jaywoo. Lee
<b>Manufacturer :</b>	Samsung Electronics Co., Ltd. 129, Samsung-ro, Yeongtong-gu, Suwon-si, Gyeonggi-do, Korea 443-742

- FCC ID: A3LWIDT30Q
- IC : 649E-WIDT30Q
- Model: WIDT30Q
- Brand Name: SAMSUNG
- EUT Type: WiFi module
- Classification: Unlicensed National Information Infrastructure (UNII)
- Applied Standard: FCC 47 CFR Part 15.407 and IC RSS-210 Issue 8
- Test Procedure(s): ANSI C63.4-2003, ANSI C63.10-2009 and FCC guidance of 789033 D01 General UNII Test Procedures v01r02 dated September 26, 2012 entitled "Guidelines for Compliance Testing of Unlicensed National Information Infrastructure (UNII) Devices – Part 15, Subpart E"
- Dates of Test: November 21, 2012 ~ December 27, 2012
- Place of Tests: Nemko Korea Co., Ltd.

## 2. INTRODUCTION

### 2.1 Test facility

The measurement procedure described in American National Standard for Methods of Measurement of Radio-Noise Emissions from Low-Voltage Electrical and Electronic Equipment in the Range of 9 kHz to 40 GHz (ANSI C63.4-2003), the American National Standard for Testing Unlicensed Wireless Devices (ANSI C63.10-2009) was used in determining radiated and conducted emissions emanating from **Samsung Electronics Co., Ltd.**

**FCC ID : A3LWIDT30Q and IC : 649E-WIDT30Q**

These measurement tests were conducted at **Nemko Korea Co., Ltd. EMC Laboratory**.

The site address 155 & 159, Osan-Ro, Mohyeon-Myeon, Cheoin-Gu, Yongin-Si, Gyeonggi-Do 449-852 KOREA, REPUBLIC OF.

The area of Nemko Korea Corporation Ltd. EMC Test Site is located in a mountain area at 80 km (48 miles) southeast and Incheon International Airport (Incheon Airport), 30 km (18miles) south-southeast from central Seoul.

It is located in the valley surrounded by mountains in all directions where ambient radio signal conditions are quiet and a favorable area to measure the radio frequency interference on open field test site for the computing and ISM devices manufactures.







The detailed description of the measurement facility was found to be in compliance with the requirements of §2.948 according to ANSI C63.4 2003.



Nemko Korea Co., Ltd.  
EMC Lab.  
155 & 159, Osan-Ro, Mohyeon-Myeon,  
Cheoin-Gu, Yongin-Si, Gyeonggi-Do  
449-852 KOREA, REPUBLIC OF  
Tel)+82-31-330-1700  
Fax)+82-31-322-2332

Fig. 1. The map above shows the Seoul in Korea vicinity area.  
The map also shows Nemko Korea Corporation Ltd. EMC Lab. and Incheon Airport.

## 2.2 Accreditation and listing

	Accreditation type	Accreditation number
	FCC part 15/18 Filing site	Registration No. 97992
	CAB Accreditation for DOC	Designation No. KR0026
	KOLAS Accredited Lab. (Korea Laboratory Accreditation Scheme)	Registration No. 155
	Canada IC Registered site	Site No. 2040E
	VCCI registration site(RE/CE/Telecom CE)	Member No. 2118
	EMC CBTL	-
	KCC(RRL)Designated Lab.	Registration No. KR0026
	SASO registered Lab and Certification Body	Registration No. 2008-15

### 3. TEST CONDITIONS & EUT INFORMATION

#### 3.1 Operation During Test

The EUT is the MIMO transceiver which is module supporting the 802.11a/b/g/n mode (802.11a/b/g :1TX/1RX, 802.11n: 2TX/2RX).

During the test, the EUT was connected to laptop PC and then a test program was executed to operate EUT continuously. The operating voltage of EUT was 5 Vdc supplied from a USB port on Laptop PC. The EUT was tested at the lowest channel, middle channel and the highest channel with the maximum output power in accordance with the manufacturer's specifications. The worst data were recorded in the report.

##### 3.1.1 Table of test channels

Frequency band	Mode	Test Channel (CH)	Frequency (MHz)
Band I	802.11a	36	5180
		40	5200
		48	5240
	802.11n(20 MHz)	36	5180
		40	5200
		48	5240
	802.11n(40 MHz)	38	5190
		46	5230
	Band II	802.11a	52
56			5280
64			5320
802.11n(20 MHz)		52	5260
		56	5280
		64	5320
802.11n(40 MHz)		54	5270
		62	5310
Band III		802.11a	100
	116		5580
	140		5700
	802.11n(20 MHz)	100	5500
		116	5580
		140	5700
	802.11n(40 MHz)	102	5510
		118	5590
		134	5670



**3.1.2 Table of test modes**

Test Items	Mode	Data rate (Mbps)	Test Channel (CH)
Conducted Emissions	802.11n(20 MHz)	13.5	56
Radiated Emissions	802.11n(20 MHz)	13.5	56
26 dB Spectrum Bandwidth	802.11a	6	36/40/48 52/56/64 100/116/140
	802.11n(20 MHz)	6.5	36/40/48 52/56/64 100/116/140
	802.11n(40 MHz)	13.5	38/46 54/62 102/118/134
Maximum Conducted Output Power	802.11a	6	36/40/48 52/56/64 100/116/140
	802.11n(20 MHz)	6.5	36/40/48 52/56/64 100/116/140
	802.11n(40 MHz)	13.5	38/46 54/62 102/118/134
Power Spectral Density	802.11a	6	36/40/48 52/56/64 100/116/140
	802.11n(20 MHz)	6.5	36/40/48 52/56/64 100/116/140
	802.11n(40 MHz)	13.5	38/46 54/62 102/118/134
Peak Excursion Measurement	802.11a	6	36
	802.11n(20 MHz)	6.5	36
	802.11n(40 MHz)	13.5	38
Frequency Stability	-	-	40/56/116



**3.2 Support Equipment**

EUT	Samsung Electronics Co., Ltd. FCC ID: A3LWIDT30Q	S/N: N/A
Laptop Computer	Samsung Electronics Co., Ltd. Model : NT-R55 0.3 m unshielded pin connector cable	FCC DOC S/N : 408L93AP400115W
AC/DC Adapter	Chicony Power Technology Co., Ltd. Model : AD-9019S 1.5 m unshielded power cable	FCC DOC S/N : CNBA4400215ADON81BT01V8

**3.3 Setup Drawing**

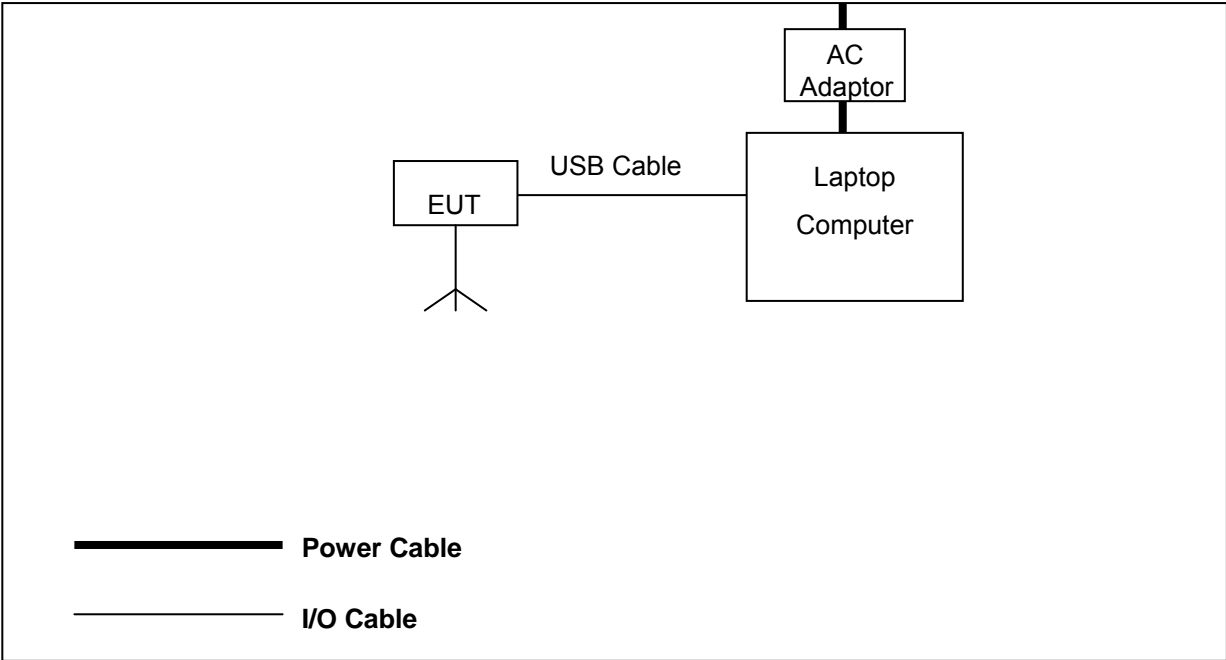

### 3.4 EUT Information

The EUT is the **Samsung WiFi module FCC ID: A3LWIDT30Q, IC: 649E-WIDT30Q.**

Specifications:

Category	WiFi module
Model Name	WIDT30Q
Brand Name	SAMSUNG
Frequency of Operation	<u>For Band I</u> 802.11a,n(20 MHz): 5180 MHz ~ 5240 MHz 802.11n(40 MHz) : 5190 MHz ~ 5230 MHz <u>For Band II</u> 802.11a,n(20 MHz): 5260 MHz ~ 5320 MHz 802.11n(40 MHz) : 5270 MHz ~ 5310 MHz <u>For Band III</u> 802.11a,n(20 MHz): 5500 MHz ~ 5700 MHz 802.11n(40 MHz) : 5510 MHz ~ 5670 MHz
Power Output (Conducted)	<u>For Band I</u> 802.11a : 12.89 dBm 802.11n(20 MHz) : 13.42 dBm 802.11n(40 MHz) : 13.33 dBm <u>For Band II</u> 802.11a : 15.12 dBm 802.11n(20 MHz) : 15.22 dBm 802.11n(40 MHz) : 14.44 dBm <u>For Band III</u> 802.11a : 15.40 dBm 802.11n(20 MHz) : 16.17 dBm 802.11n(40 MHz) : 12.56 dBm
Channels	<u>For Band I</u> 802.11a, n(20 MHz) : 4 CH 802.11n(40 MHz): 2 CH <u>For Band II</u> 802.11a, n(20 MHz) : 4 CH 802.11n(40 MHz): 2 CH <u>For Band III</u> 802.11a, n(20 MHz) : 11 CH 802.11n(40 MHz): 5 CH
Antenna Gain (peak)	<u>For Band I and II</u> Ant 0 : 2.69 dBi, Ant1 : 2.50 dBi <u>For Band III</u> Ant 0 : 1.30 dBi, Ant1 : -0.25 dBi

Antenna setup	802.11a : 1TX / 1RX 802.11n(20 MHz), 802.11n(40 MHz) : 2TX / 2RX
Modulations	OFDM(BPSK,QPSK,16QAM,64QAM) for 802.11a,g,n
Temperature Range	-20 °C ~ +50 °C
Voltage	5.0 Vdc
Dimensions (D x W x H)	58.00 mm x 31.45 mm X 8.50 mm
Weight	10.7 g
Remarks	-

## IEEE 802.11n specification :

CS Index	Spatial Streams	Modulation Type	Coding Rate	Data Rate Mb/s			
				20 MHz		40 MHz	
				800ns GI	400ns GI	800ns GI	400ns GI
0	1	BPSK	1/2	6.5	7.2	13.5	15.0
1	1	QPSK	1/2	13.0	14.4	27.0	30.0
2	1	QPSK	3/4	19.5	21.7	40.5	45.0
3	1	16-QAM	1/2	26.0	28.9	54.0	60.0
4	1	16-QAM	3/4	39.0	43.3	81.0	90.0
5	1	64-QAM	2/3	52.0	57.8	108.0	120.0
6	1	64-QAM	3/4	58.5	65.0	121.5	135.0
7	1	64-QAM	5/6	65.0	72.2	135.0	150.0
8	2	BPSK	1/2	13.0	14.4	27.0	30.0
9	2	QPSK	1/2	26.0	28.9	54.0	60.0
10	2	QPSK	3/4	39.0	43.3	81.0	90.0
11	2	16-QAM	1/2	52.0	57.8	108.0	120.0
12	2	16-QAM	3/4	78.0	86.7	162.0	180.0
13	2	64-QAM	2/3	104.0	115.6	216.0	240.0
14	2	64-QAM	3/4	117.0	130.0	243.0	270.0
15	2	64-QAM	5/6	130.0	144.4	270.0	300.0

## 4. SUMMARY OF TEST RESULTS

---

The EUT has been tested according to the following specification:

Name of Test	FCC Paragraph No.	IC Paragraph No.	Result	Remark
Conducted Emission	15.207	RSS-GEN 7.2.4	Complies	
Radiated Emission	15.209	RSS-210 Issue 8 A9.2	Complies	
26 dB Spectrum Bandwidth	15.407(a)	RSS-210 Issue 8 A9.2	Complies	
Maximum Conducted Output Power	15.407(a)	RSS-210 Issue 8 A9.2	Complies	
Power Spectral Density	15.407(a)	RSS-210 Issue 8 A9.2	Complies	
Peak Excursion Measurement	15.407(a)	-	Complies	
Radiated Spurious Emission	15.407(b)	RSS-210 Issue 8 A9.2	Complies	
Frequency Stability	15.407(g)	-	Complies	
Maximum Permissible Exposure	1.1307(b)	RSS-102	Complies	

## 5. RECOMMENDATION/CONCLUSION

---

The data collected shows that the **Samsung WiFi module FCC ID: A3LWIDT30Q, IC : 649E-WIDT30Q** is in compliance with Part 15.407 of the FCC Rule and RSS-210 Issue 8 of the IC Specification.

## 6. ANTENNA REQUIREMENTS

---

### §15.203 of the FCC Rules part 15 Subpart C

: An intentional radiator shall be designed to ensure that no antenna other than that furnished by the responsible party shall be used with the device. The use of a permanently attached antenna or of an antenna that uses a unique coupling to the intentional radiator shall be considered sufficient to comply with the provisions of this section.

The antenna of the **Samsung WiFi module FCC ID: A3LWIDT30Q, IC: 649E-WIDT30Q** is **permanently attached** and there are no provisions for connection to an external antenna. It complies with the requirement of §15.203.

According to “662911 D01 Multiple Transmitter Output v01r02”, if two antennas are unequal antenna gains and transmit signals are correlated, then the **Directional gain =  $10 \log[(10^{G1/20} + 10^{G2/20})^2 / N_{ANT}]$  dBi**. The directional gain of Samsung WiFi module are **5.69 dBi for Band I, II** and **3.57 dBi for Band III**.

## 7. DESCRIPTION OF TESTS

### 7.1 Conducted Emissions

The Line conducted emission test facility is located inside a 4 x 7 x 2.5 meter shielded enclosure. It is manufactured by EM engineering. The shielding effectiveness of the shielded room is in accordance with MIL-STD-285 or NSA 65-6. A 1 m x 1.5 m wooden table 0.8 m height is placed 0.4 m away from the vertical wall and 1.5 m away from the side of wall of the shielded room Rohde & Schwarz (ESH3-Z5) and (ESH2-Z5) of the 50 ohm/50  $\mu$ H Line Impedance Stabilization Network (LISN) are bonded to the shielded room. The EUT is powered from the Rohde & Schwarz LISN (ESH3-Z5) and the support equipment is powered from the Rohde & Schwarz LISN (ESH2-Z5). Power to the LISNs are filtered by high-current high insertion loss Power line filters. The purpose of filter is to attenuate ambient signal interference and this filter is also bonded to shielded enclosure. All electrical cables are shielded by tinned copper zipper tubing with inner diameter of 1 / 2 ". If DC power device, power will be derived from the source power supply it normally will be powered from and this supply lines will be connected to the LISNs, All interconnecting cables more than 1 meter were shortened by non inductive bundling (serpentine fashion) to a 1 meter length. Sufficient time for EUT, support equipment, and test equipment was allowed in order for them to warm up to their normal operating condition. The RF output of the LISN was connected to the spectrum analyzer to determine the frequency producing the maximum EME from the EUT. The spectrum was scanned from 150 kHz to 30 MHz with 200 msec sweep time. The frequency producing the maximum level was re-examined using the EMI test receiver. (Rohde & Schwarz ESCS30). The detector functions were set to CISPR quasi-peak mode & average mode. The bandwidth of receiver was set to 9 kHz. The EUT, support equipment, and interconnecting cables were arranged and manipulated to maximize each EME emission. Each emission was maximized by; switching power lines; varying the mode of operation or resolution; clock or data exchange speed; scrolling H pattern to the EUT and of support equipment, and powering the monitor from the floor mounted outlet box and computer aux AC outlet, if applicable; whichever determined the worst case emission. Each EME reported was calibrated using the R&S signal generator.

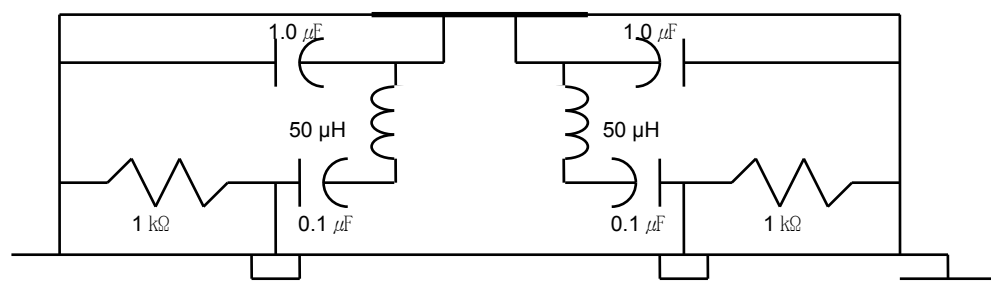

Fig. 2. LISN Schematic Diagram

## **7.2 Radiated Emissions**

The measurement was performed at the test site that is specified in accordance with ANSI C63.4-2003 and ANCI C63.10-2009.

The spurious emission was scanned from 9 kHz to 30 MHz using Loop Antenna(Rohde&Schwarz, HFH2-Z2) and 30 to 1000 MHz using Trilog broadband test antenna(Schwarzbeck, VULB 9163). Above 1 GHz, Horn antenna (Schwarzbeck BBHA 9120D: up to 18 GHz, Q-par Angus QSH20S20 : 18 to 26.5 GHz, QSH22K20: up to 40 GHz) was used.

The test equipment was placed on turntable with 0.8 m above ground. Sufficient time for the EUT, support equipment, and test equipment was allowed in order for them to warm up to their normal operating condition. The EUT, cable, wire arrangement and mode of operation that has the highest amplitude relative to the limit was selected. Then, the turn table was rotated from 0° to 360° and an antenna mast was moved from 1 m to 4 m height to maximize the suspected highest amplitude signal. The final maximized level was recorded.

### **Unwanted emissions in the restricted bands**

At frequencies below 1000 MHz, measurements performed using the CISPR quasi-peak detection.

At frequencies above 1000 MHz, measurements performed using the peak and average measurement procedures described in KDB “789033 D01 General UNII Test Procedures v01r02” in section G)5) and G)6). Peak emission levels was measured by setting the analyzer RBW = 1 MHz, VBW = 3 MHz, Detector = Peak, Trace mode = max hold. Average emission levels was measured using the “Method VB” by setting the analyzer RBW = 1 MHz, VBW = 300 Hz ( $VBW \leq RBW/100$ ), Detector = Peak if, if the EUT is configured to transmit with duty cycle  $\geq 98$  percent. When the duty cycle  $\leq 98$  percent,  $VBW \geq 1/T$  ( $T$  = minimum transmission duration over which the transmitter is on) was used.

### **Unwanted emissions outside of the restricted bands**

At frequencies below 1000 MHz, measurements performed using the CISPR quasi-peak detection.

At frequencies above 1000 MHz, measurements performed using the peak and average measurement procedures described in KDB “789033 D01 General UNII Test Procedures v01r02” in section G)5). Peak emission levels was measured by setting the analyzer RBW = 1 MHz, VBW = 3 MHz, Detector = Peak, Trace mode = max hold.



### 7.3 26 dB Bandwidth and 99% Occupied bandwidth

#### Test Setup

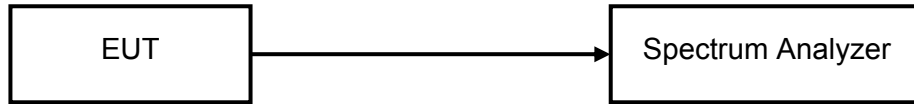

#### Test Procedure

EUTs 26 dB bandwidth is measured at low, middle, high channels with a spectrum analyzer connected to the antenna terminal while the EUTs operating at its maximum power control level.

The spectrum analyzer setting is as follows.

RBW = approximately 1 % of the emission bandwidth

VBW > RBW

Detector = Peak

Trace mode = max hold

The bandwidth measurement function on the spectrum analyzer is used to measure the 26 dB bandwidth and 99% occupied bandwidth.

## 7.4 Maximum Peak Output Power

### Test Setup

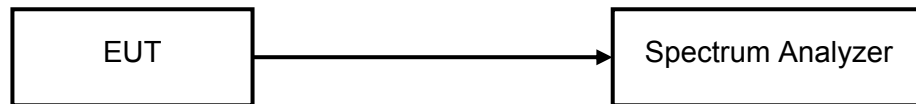

### Test Procedure

EUTs Maximum Conducted Output Power is measured at low, middle, high channels with a spectrum analyzer connected to the antenna terminal while the EUTs operating at its maximum power control level.

The spectrum analyzer setting is as follows.

RBW = 1 MHz

VBW  $\geq$  3 MHz

Number of points in sweep  $\geq$  2 Span / RBW

Sweep time = auto

Detector = RMS

Trace average at least 100 traces in power averaging mode

The band power measurement function on the spectrum analyzer is used to measure the Maximum conducted output power.

## 7.5 Peak Power Spectral Density

### Test Setup

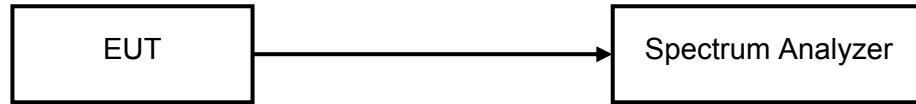

### Test Procedure

EUTs Peak Power Spectral Density is measured at low, middle, high channels with a spectrum analyzer connected to the antenna terminal while the EUTs operating at its maximum power control level.

The spectrum analyzer setting is as follows.

RBW = 1 MHz

VBW  $\geq$  3 MHz

Number of points in sweep  $\geq$  2 Span / RBW

Sweep time = auto

Detector = RMS

Trace average at least 100 traces in power averaging mode

The peak search function on the spectrum analyzer is used to find the peak of the spectrum.

## 7.6 Peak Excursion Measurement

### Test Setup

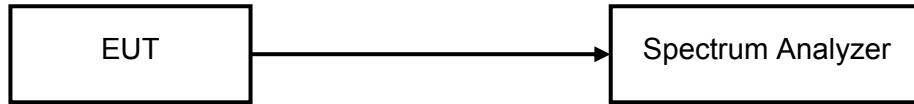

### Test Procedure

EUTs Peak Excursion is measured at middle channel with a spectrum analyzer connected to the antenna terminal while the EUTs operating at its maximum power control level.

The spectrum analyzer setting is as follows.

Trace 1)

RBW = 1 MHz

VBW  $\geq$  3 MHz

Detector = peak

Trace mode = max-hold

The sweeps is set to continue until the trace stabilizes.

The peak search function on the spectrum analyzer is used to find the peak of the spectrum.

Trace 2)

RBW = 1 MHz

VBW  $\geq$  3 MHz

Number of points in sweep  $\geq$  2 Span / RBW

Sweep time = auto

Detector = RMS

Trace average at least 100 traces in power averaging mode

The ratio of the maximum of the peak max hold spectrum to the PPSD is computed.

## 7.7 Frequency Stability

### Test Set-up:

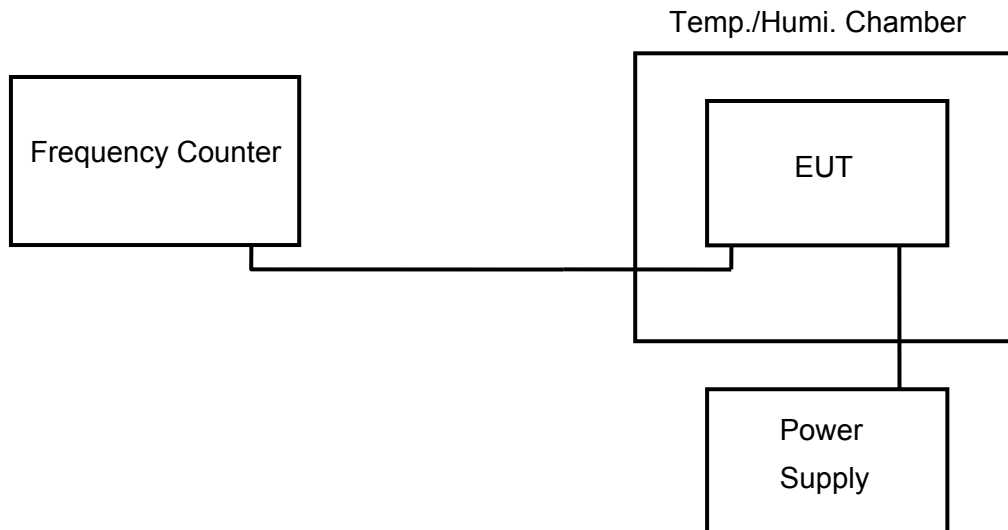

### Test Procedure

EUTs Frequency Stability is measured at center channel with a Frequency Counter connected to the antenna terminal while the EUTs operating at its non-modulated signal.

$f_c$  is declaring of channel frequency. Then the frequency error formula is  $(f_c - f) / f_c \times 10^6$  ppm.

The test extreme voltage is to change the primary supply voltage from 85 to 115 percent of the nominal value. Extreme temperature rule is  $-30\text{ }^\circ\text{C} \sim 50\text{ }^\circ\text{C}$ .

## 8. TEST DATA

### 8.1 Conducted Emissions

#### FCC §15.207, RSS-Gen 7.2.4

Frequency (MHz)	Level(dBµV)		*)Factor (dB)	**) Line	Limit(dBµV)		Margin(dB)	
	Q-Peak	Average			Q-Peak	Average	Q-Peak	Average
0.17	53.7	35.1	0.2	N	65.0	55.0	11.3	19.9
0.24	47.9	31.8	0.2	L	62.1	52.1	14.2	20.3
0.29	42.3	26.3	0.2	N	60.5	50.5	18.2	24.2
0.36	37.1	22.0	0.2	L	58.7	48.7	21.6	26.7
0.54	36.6	23.1	0.2	N	56.0	46.0	19.4	22.9
20.15	33.0	25.2	1.7	L	60.0	50.0	27.0	24.8

**Line Conducted Emissions Tabulated Data**

**Notes:**

1. Measurements using CISPR quasi-peak mode & average mode.
2. All modes of operation were investigated and the worst -case emission are reported. See attached Plots.
3. \*) Factor = LISN + Cable Loss
4. \*\*) LINE : L = Line , N = Neutral
5. The limit is on the FCC Part section 15.207(a).

# PLOTS OF EMISSIONS

- Conducted Emission at the Mains port (Line)**

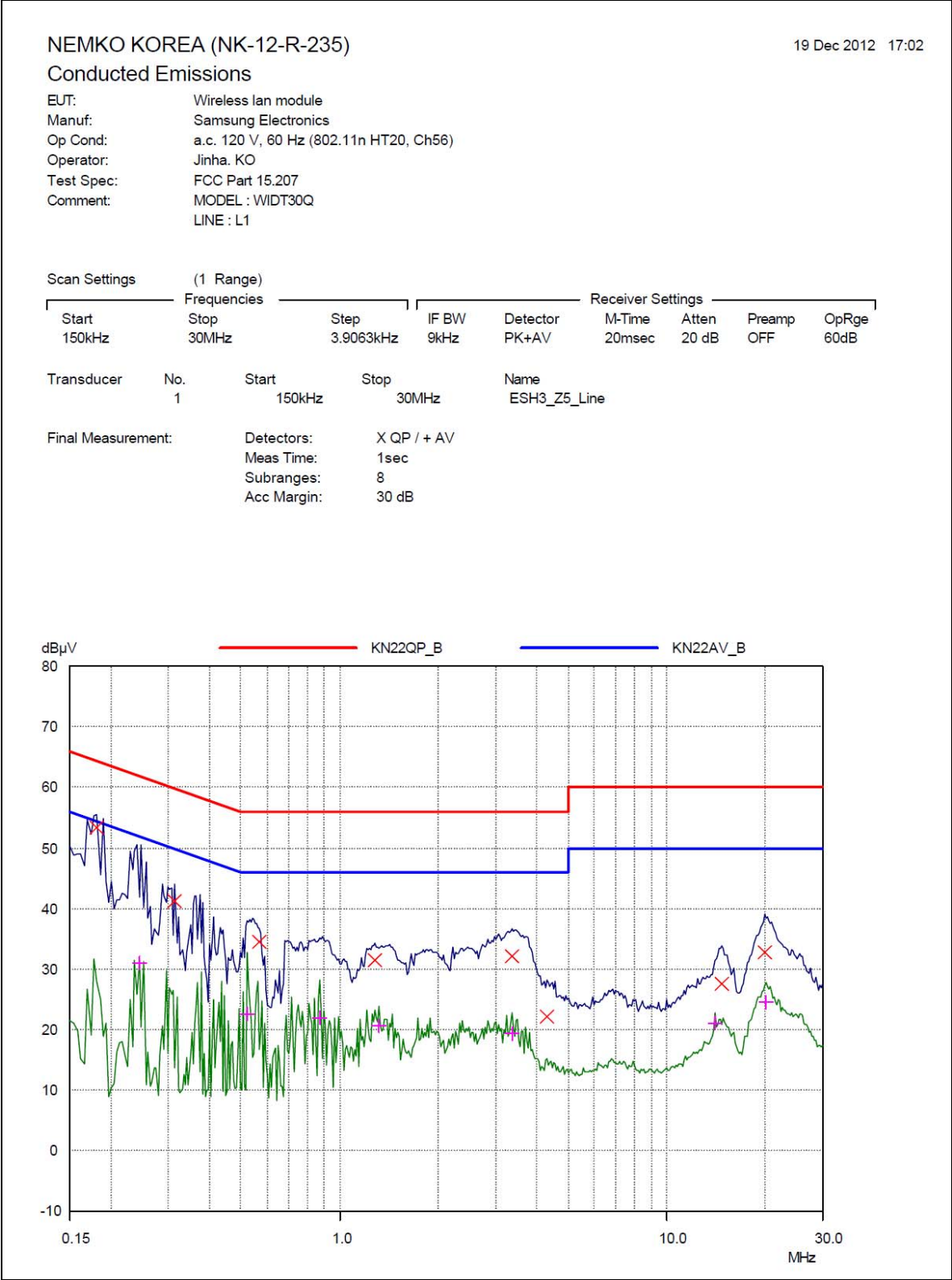



# PLOTS OF EMISSIONS

- Conducted Emission at the Mains port (Neutral)

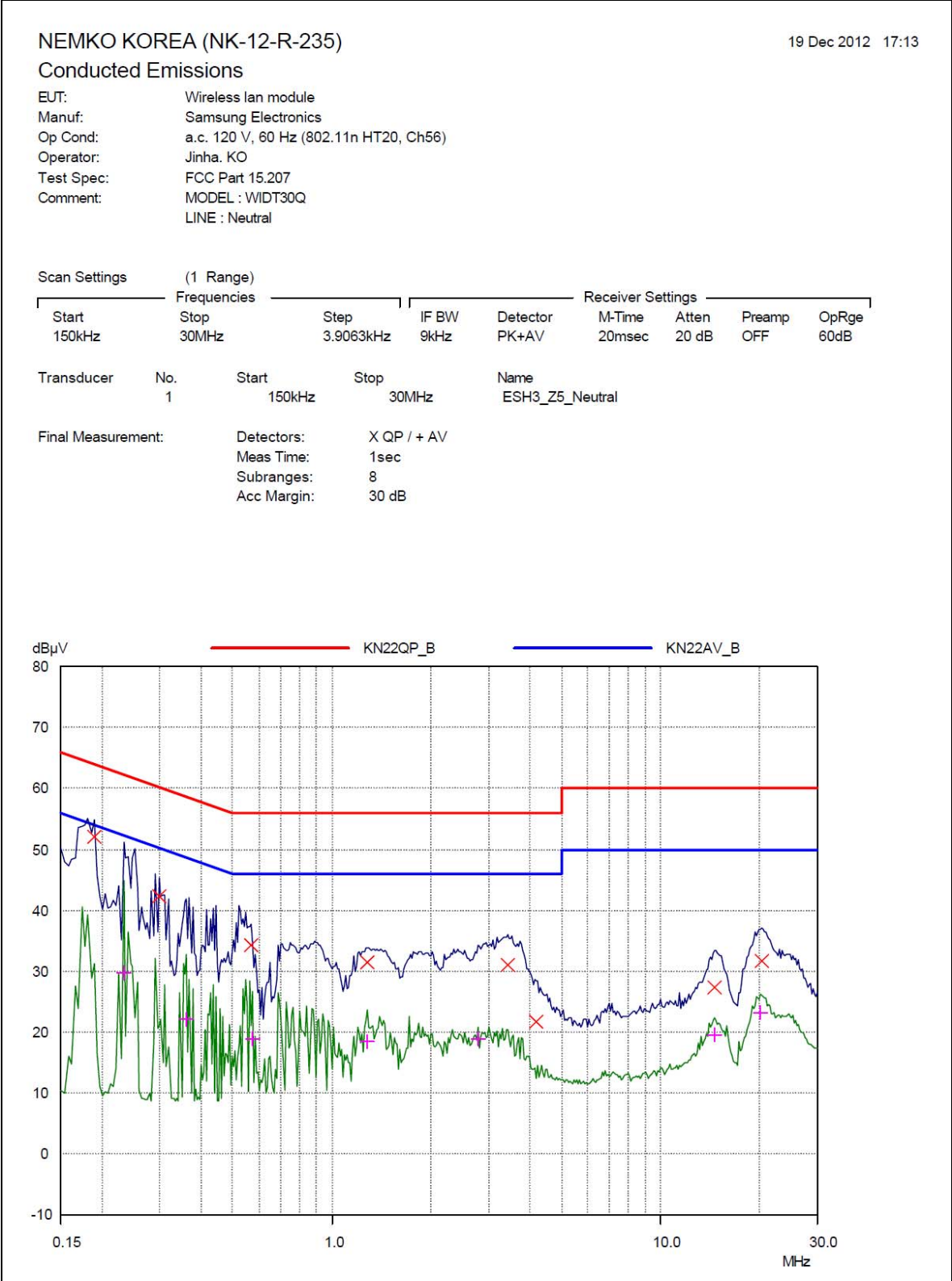

# TEST DATA

## 8.2 Radiated Emissions

### FCC §15.209, RSS-210 Issue 8, A8.5

Frequency (MHz)	Reading (dBµV/m)	Pol* (H/V)	Antenna Heights (cm)	Turntable Angles (°)	AF+CL+Amp (dB)**	Result (dBµV/m)	Limit (dBµV/m)	Margin (dB)
30.49	45.33	V	100	36	-18.0	27.3	40.0	12.7
114.44	51.21	H	278	13	-19.9	31.3	43.5	12.2
154.05	47.59	H	193	8	-15.5	32.1	43.5	11.4
240.00	60.91	H	131	341	-19.1	41.8	46.0	4.2
319.68	52.30	H	107	334	-13.6	38.7	46.0	7.3
502.45	42.50	H	109	318	-8.9	33.6	46.0	12.4

Radiated Measurements at 3meters

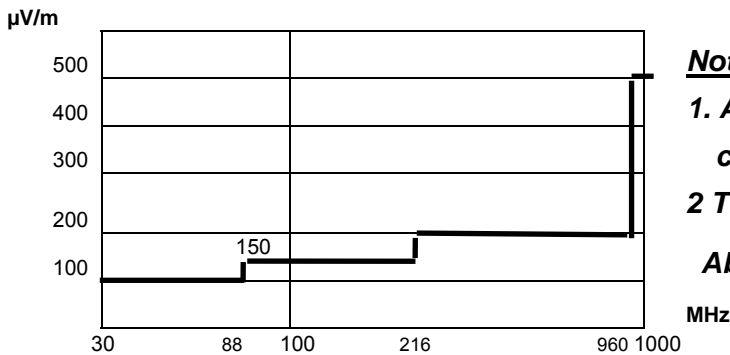

Fig. 3. Limits at 3 meters

**Notes:**

- 1. All modes were measured and the worst-case emission was reported.
- 2 The radiated limits are shown on Figure 3.
- Above 1 GHz the limit is 500 µV/m.

**Notes:**

- 1. \*Pol. H = Horizontal, V = Vertical
- 2. \*\*AF + CL + Amp. = Antenna Factor + Cable Loss + Amplifier.
- 3. Measurements using CISPR quasi-peak mode.
- 4. The radiated emissions testing were made by rotating through three orthogonal axes. The worst date was recorded.
- 5. The limit is on the FCC Part section 15.209(a).

# TEST DATA

## 8.3 26 dB Bandwidth and 99 % Occupied bandwidth

### 8.3.1 26 dB Bandwidth and 99 % Occupied bandwidth – Band I

FCC §15.407(a), RSS-210 Issue 8, A9.2

Test Mode : Set to Lowest channel, Middle channel and Highest channel

#### 802.11a mode

Channel	Frequency (MHz)	26 dB Bandwidth (MHz)		99% Occupied Bandwidth (MHz)	
		Chain 0	Chain 1	Chain 0	Chain 1
Low	5180	22.98	22.94	16.74	16.78
Middle	5200	22.36	22.91	16.71	16.75
High	5240	22.71	22.82	16.73	16.74

#### 802.11n (20 MHz) mode

Channel	Frequency (MHz)	26 dB Bandwidth (MHz)		99% Occupied Bandwidth (MHz)	
		Chain 0	Chain 1	Chain 0	Chain 1
Low	5180	22.75	22.74	17.81	17.73
Middle	5200	22.51	22.55	17.84	17.78
High	5240	22.80	22.60	17.80	17.77

#### 802.11n (40 MHz) mode

Channel	Frequency (MHz)	26 dB Bandwidth (MHz)		99% Occupied Bandwidth (MHz)	
		Chain 0	Chain 1	Chain 0	Chain 1
Low	5190	46.55	46.62	36.36	36.46
High	5230	45.85	46.67	36.51	36.45

# PLOTS OF EMISSIONS

## 802.11a mode

### Chain 0

#### **26 dB Bandwidth, Lowest Channel (5180 MHz)**

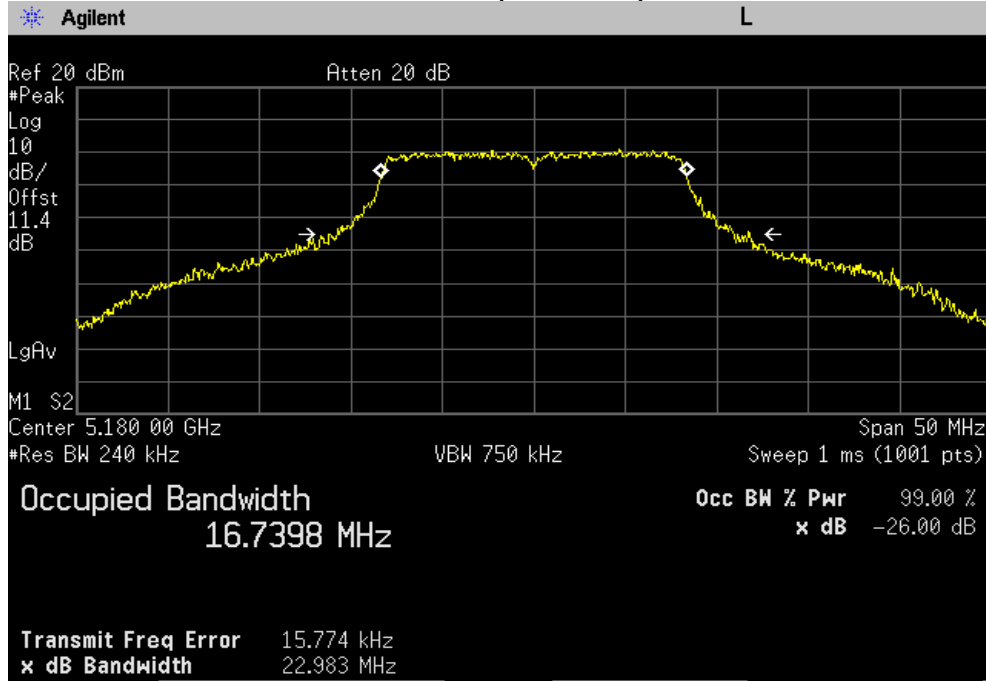

#### **26 dB Bandwidth, Middle Channel (5200 MHz)**

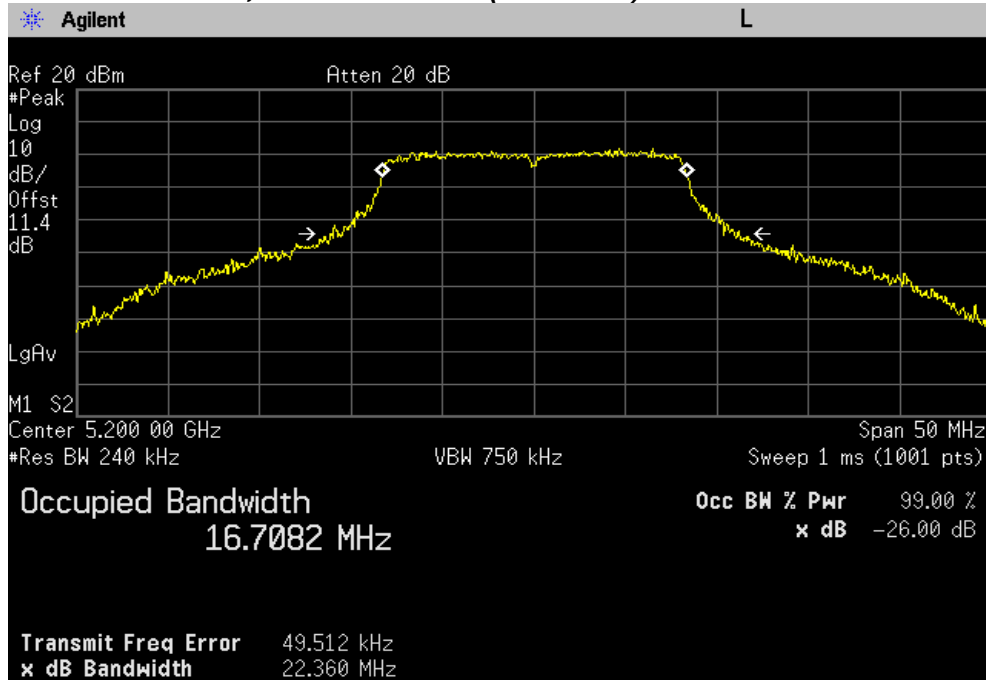

# PLOTS OF EMISSIONS

## 26 dB Bandwidth, Highest Channel (5240 MHz)

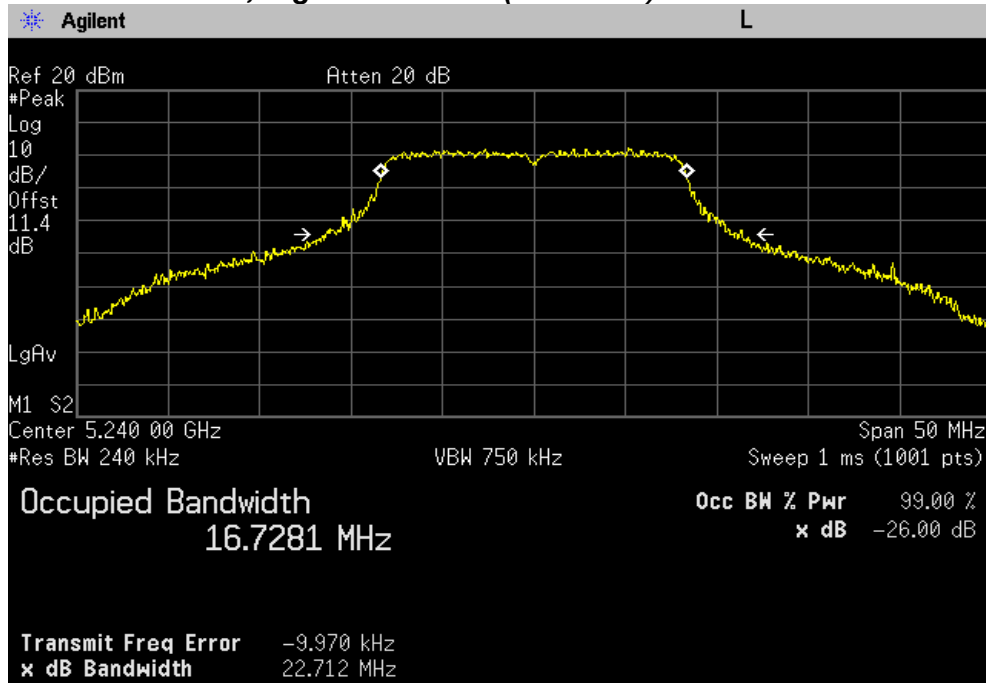

## Chain 1

## 26 dB Bandwidth, Lowest Channel (5180 MHz)

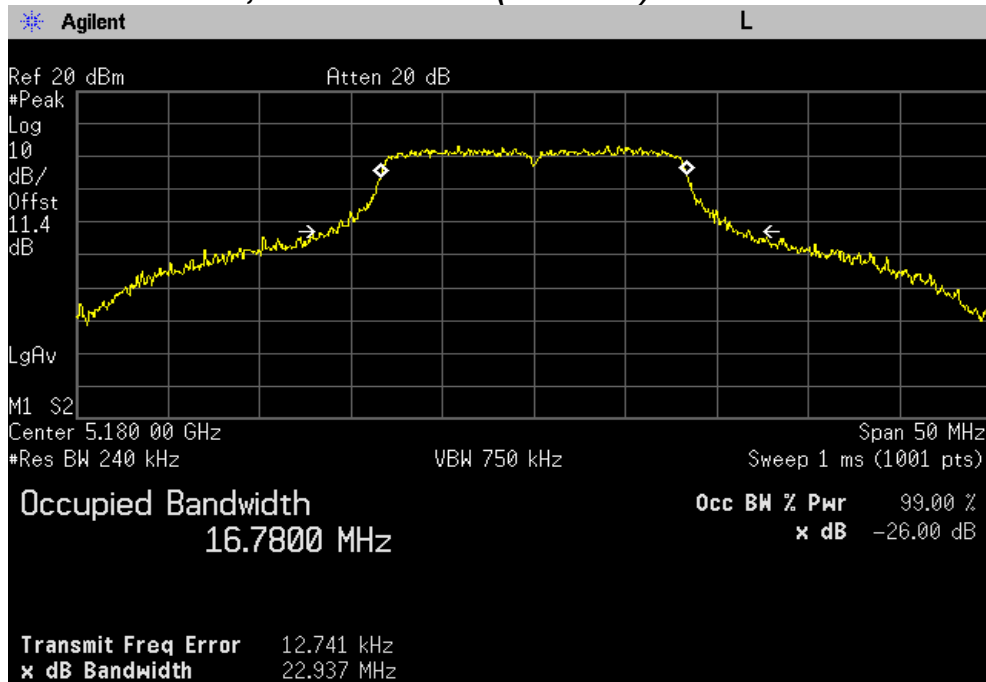

# PLOTS OF EMISSIONS

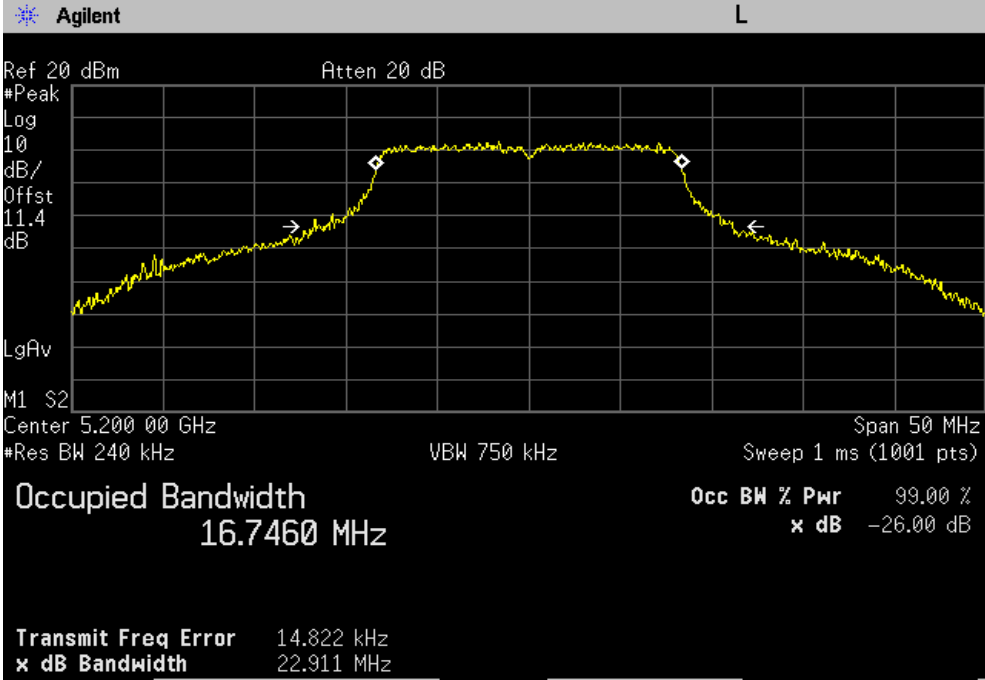
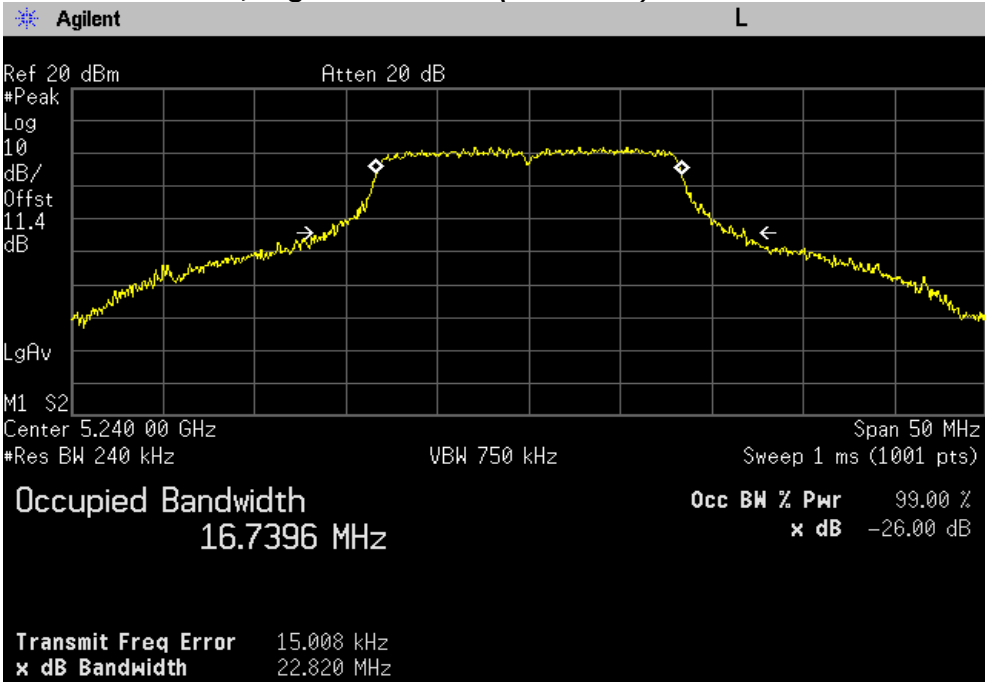
**26 dB Bandwidth, Middle Channel (5200 MHz)**

**26 dB Bandwidth, Highest Channel (5240 MHz)**

# PLOTS OF EMISSIONS

## 802.11n(20 MHz) mode

### Chain 0

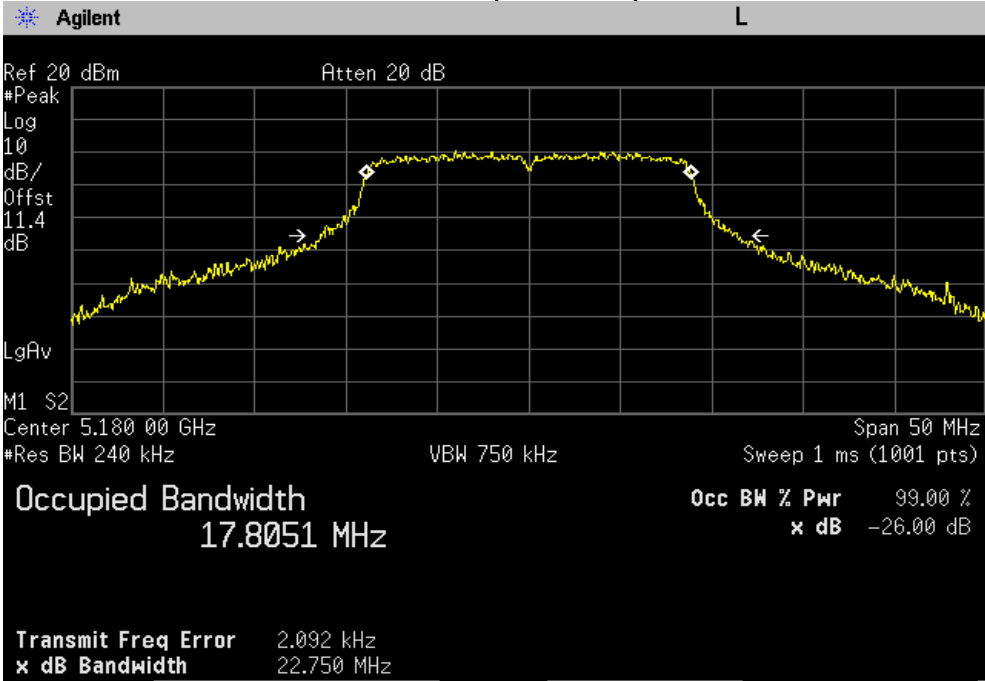
#### **26 dB Bandwidth, Lowest Channel (5180 MHz)**



#### **26 dB Bandwidth, Middle Channel (5200 MHz)**

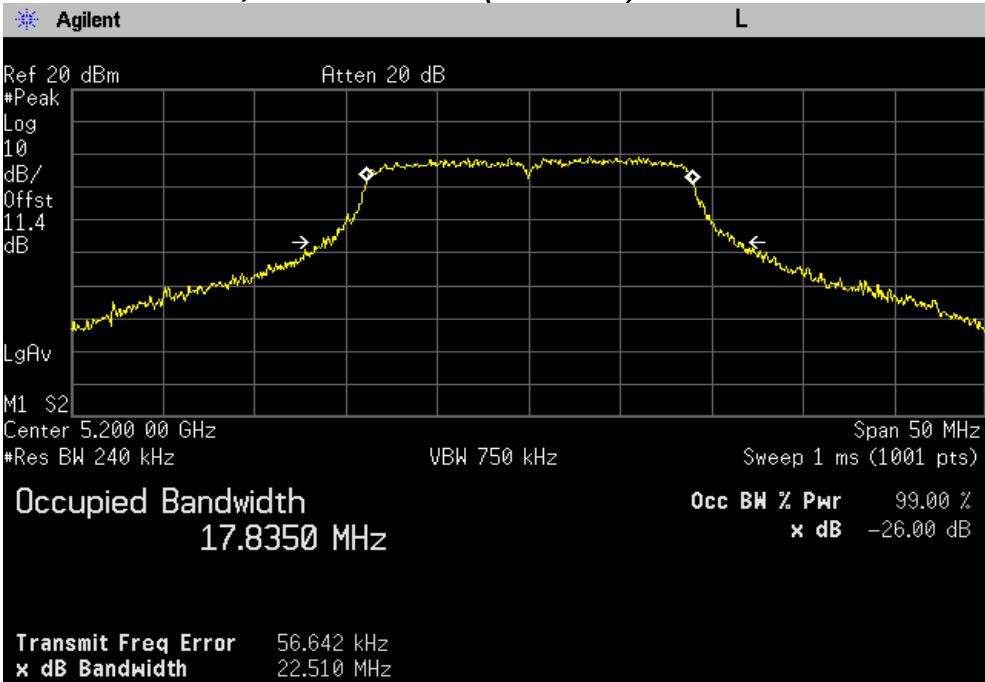



# PLOTS OF EMISSIONS

## 26 dB Bandwidth, Highest Channel (5240 MHz)

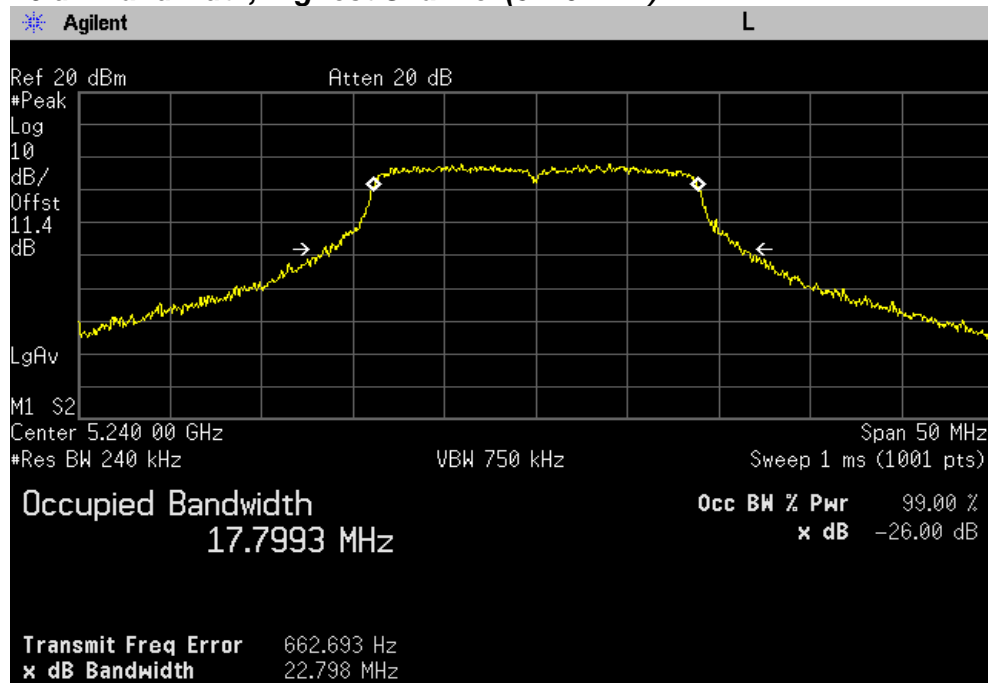

## Chain 1

## 26 dB Bandwidth, Lowest Channel (5180 MHz)

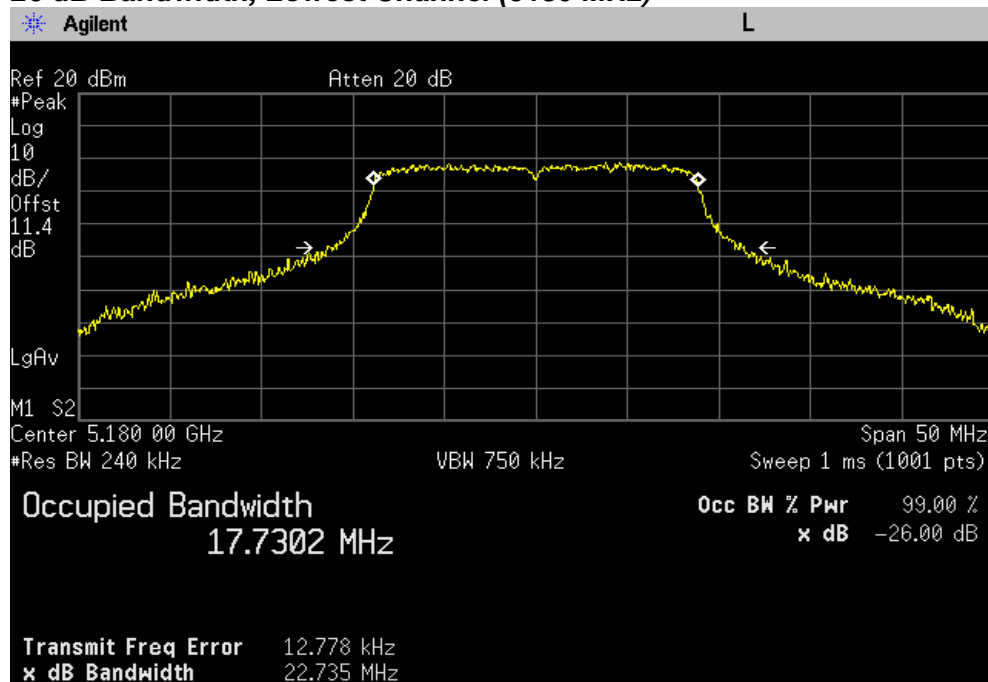

# PLOTS OF EMISSIONS

## 26 dB Bandwidth, Middle Channel (5200 MHz)

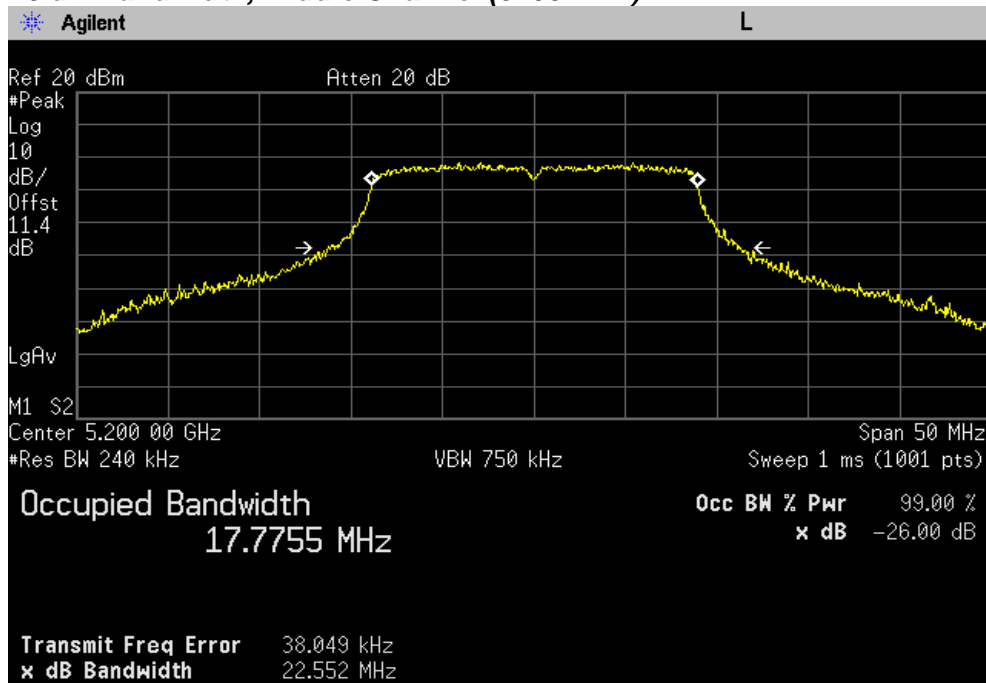

## 26 dB Bandwidth, Highest Channel (5240 MHz)

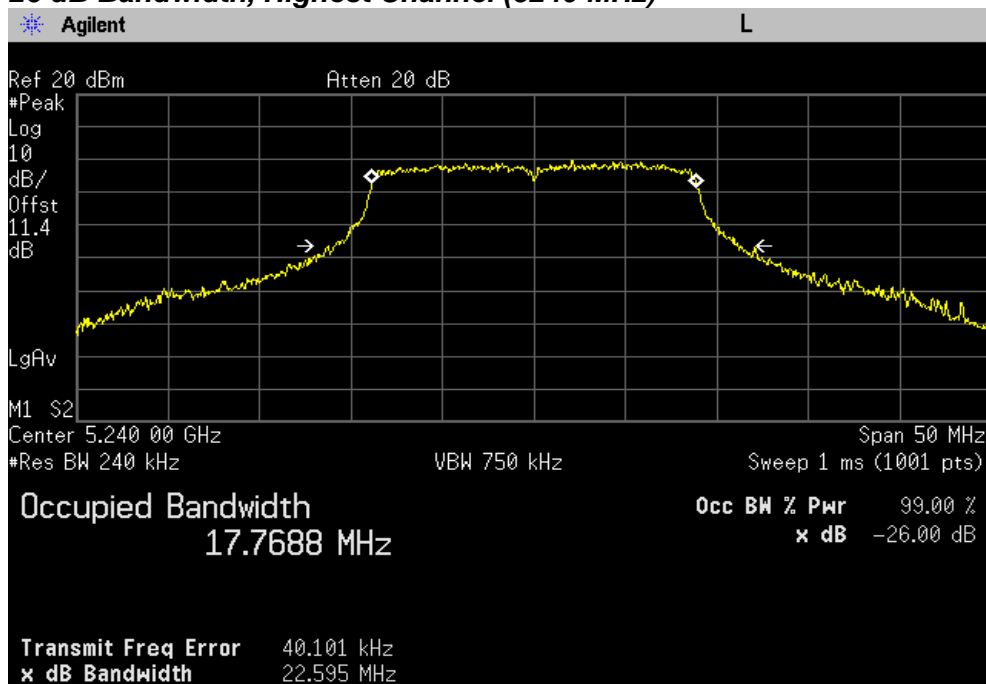

# PLOTS OF EMISSIONS

## 802.11n(40 MHz) mode

### Chain 0

#### **26 dB Bandwidth, Lowest Channel (5190 MHz)**

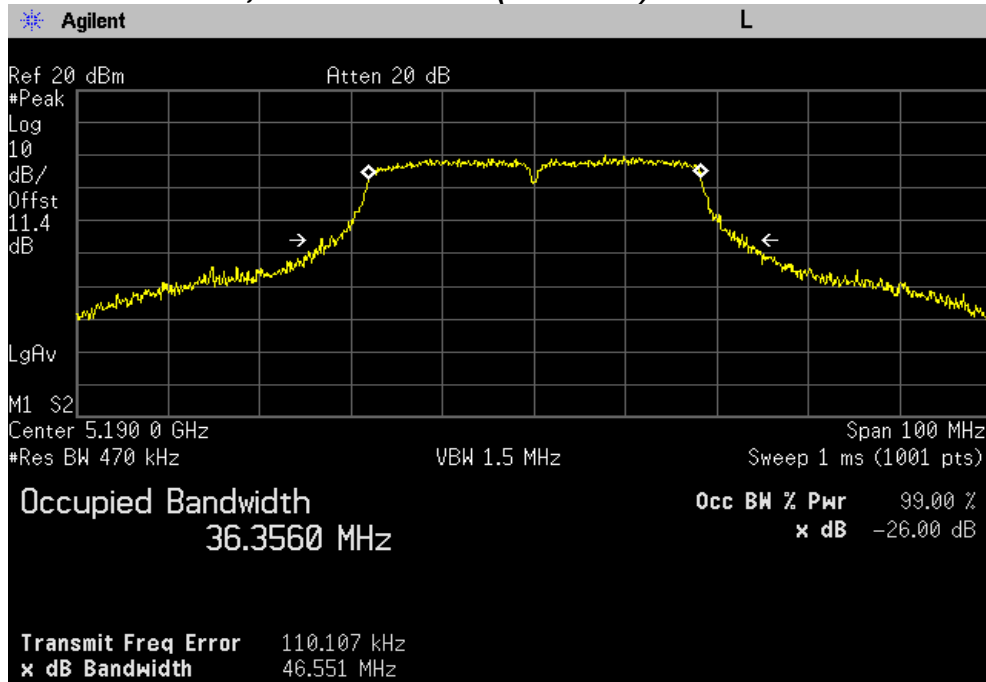

#### **26 dB Bandwidth, Highest Channel (5230 MHz)**

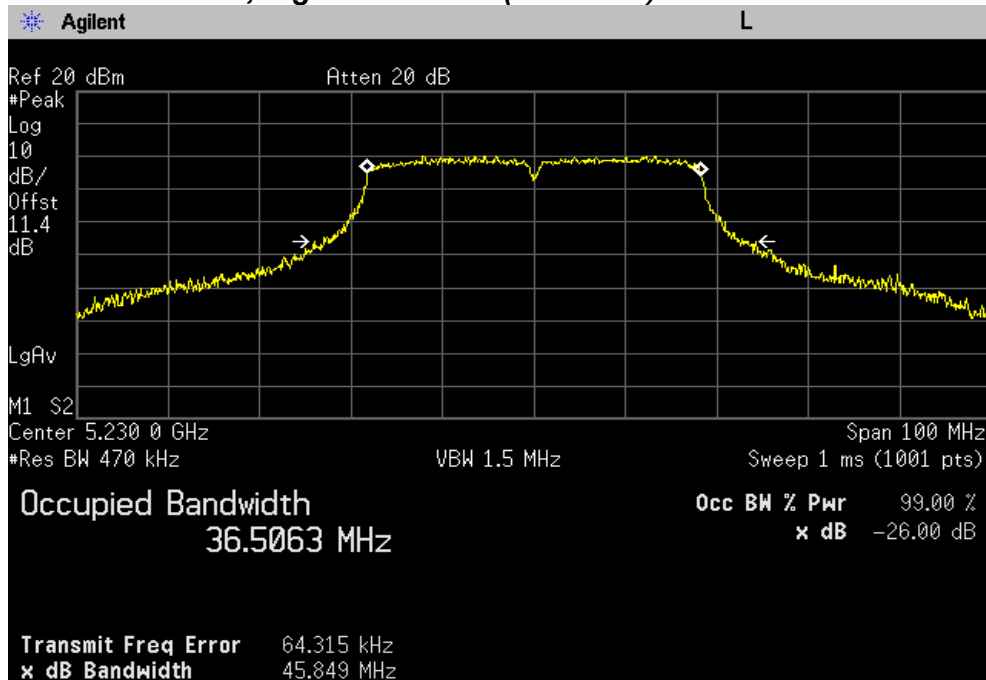

# PLOTS OF EMISSIONS

## Chain 1

### 26 dB Bandwidth, Lowest Channel (5190 MHz)

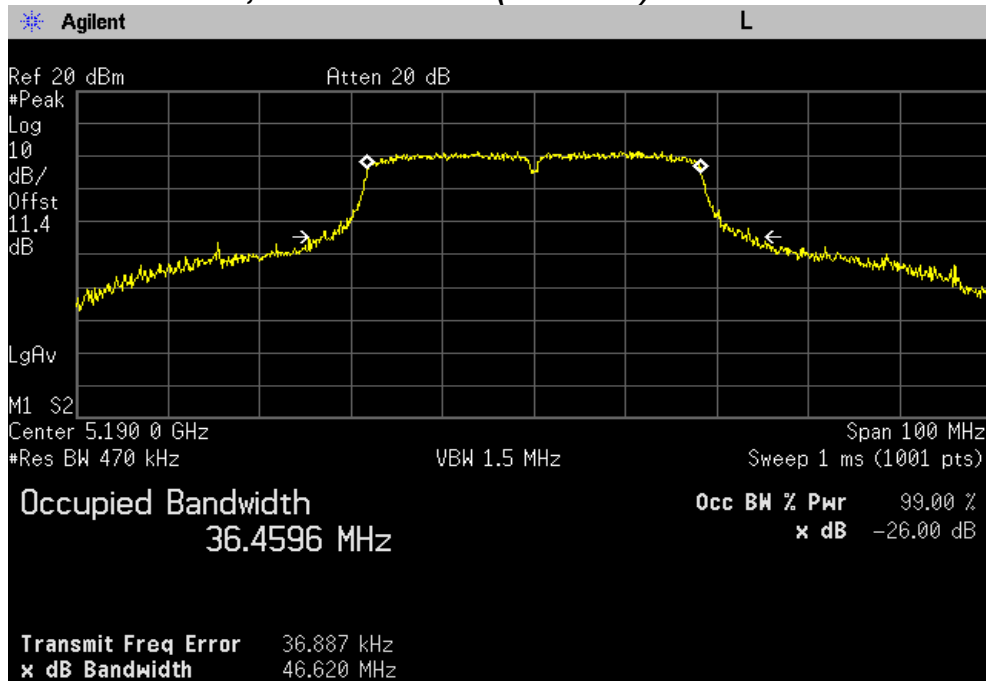

### 26 dB Bandwidth, Highest Channel (5230 MHz)

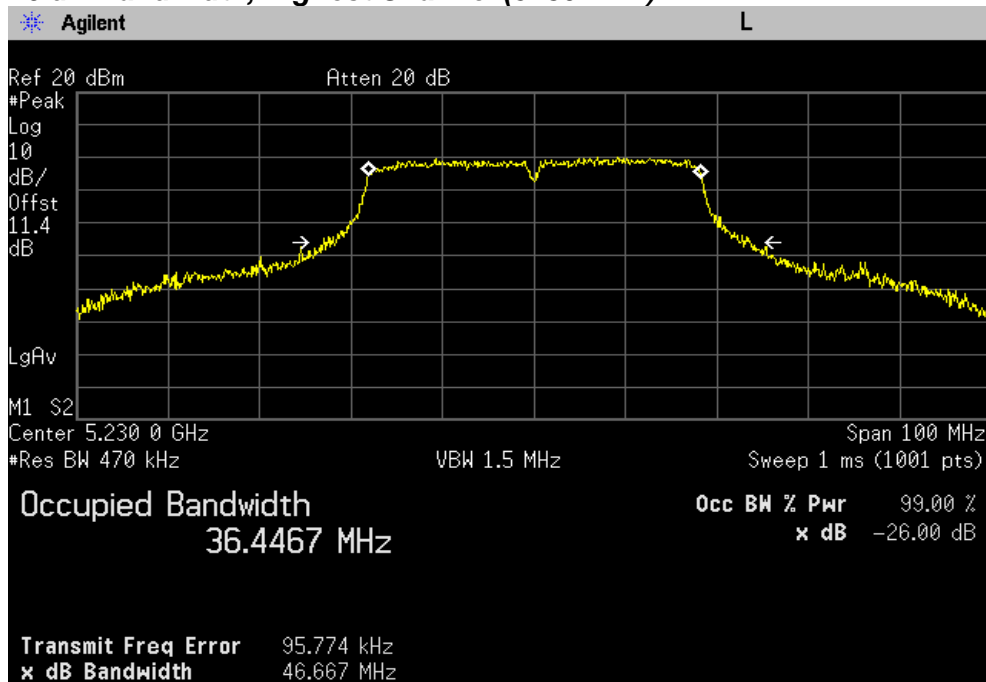

# TEST DATA

## 8.3.2 26 dB Bandwidth and 99 % Occupied bandwidth – Band II

FCC §15.407(a), RSS-210 Issue 8, A9.2

Test Mode : Set to Lowest channel, Middle channel and Highest channel

### 802.11a mode

Channel	Frequency (MHz)	26 dB Bandwidth (MHz)		99% Occupied Bandwidth (MHz)	
		Chain 0	Chain 1	Chain 0	Chain 1
Low	5260	24.57	26.15	17.05	17.04
Middle	5280	25.44	26.94	17.01	17.12
High	5320	24.37	25.92	17.03	17.14

### 802.11n (20 MHz) mode

Channel	Frequency (MHz)	26 dB Bandwidth (MHz)		99% Occupied Bandwidth (MHz)	
		Chain 0	Chain 1	Chain 0	Chain 1
Low	5260	24.37	24.98	18.01	17.92
Middle	5280	24.55	24.54	17.97	18.00
High	5320	24.40	25.26	18.03	17.96

### 802.11n (40 MHz) mode

Channel	Frequency (MHz)	26 dB Bandwidth (MHz)		99% Occupied Bandwidth (MHz)	
		Chain 0	Chain 1	Chain 0	Chain 1
Low	5270	46.92	46.81	36.62	36.49
High	5310	47.22	47.10	36.54	36.62

# PLOTS OF EMISSIONS

## 802.11a mode

### Chain 0

#### **26 dB Bandwidth, Lowest Channel (5260 MHz)**

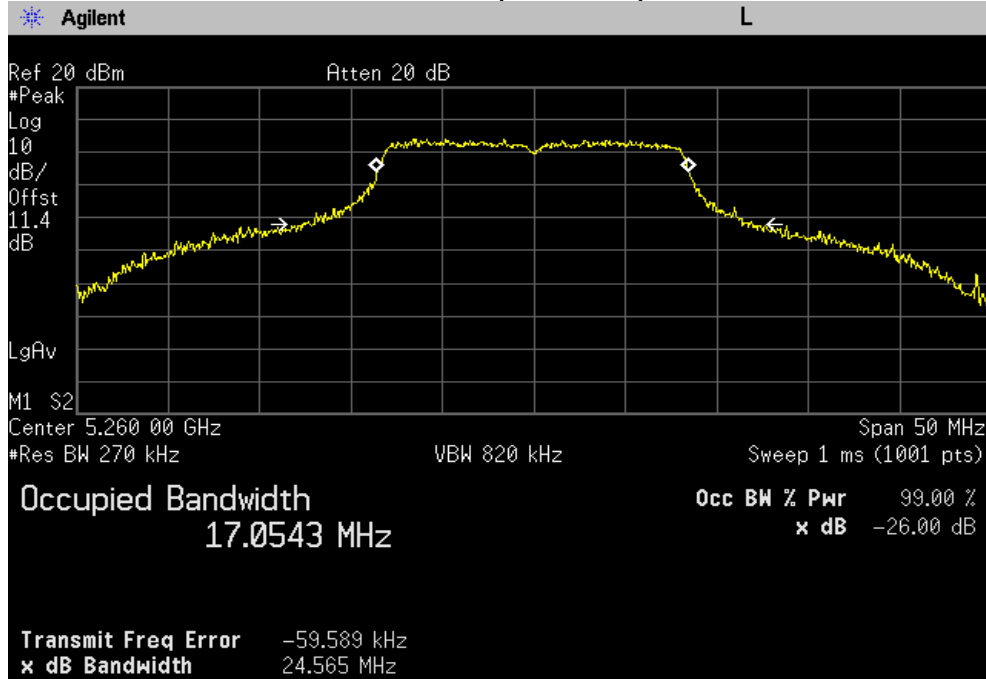

#### **26 dB Bandwidth, Middle Channel (5280 MHz)**

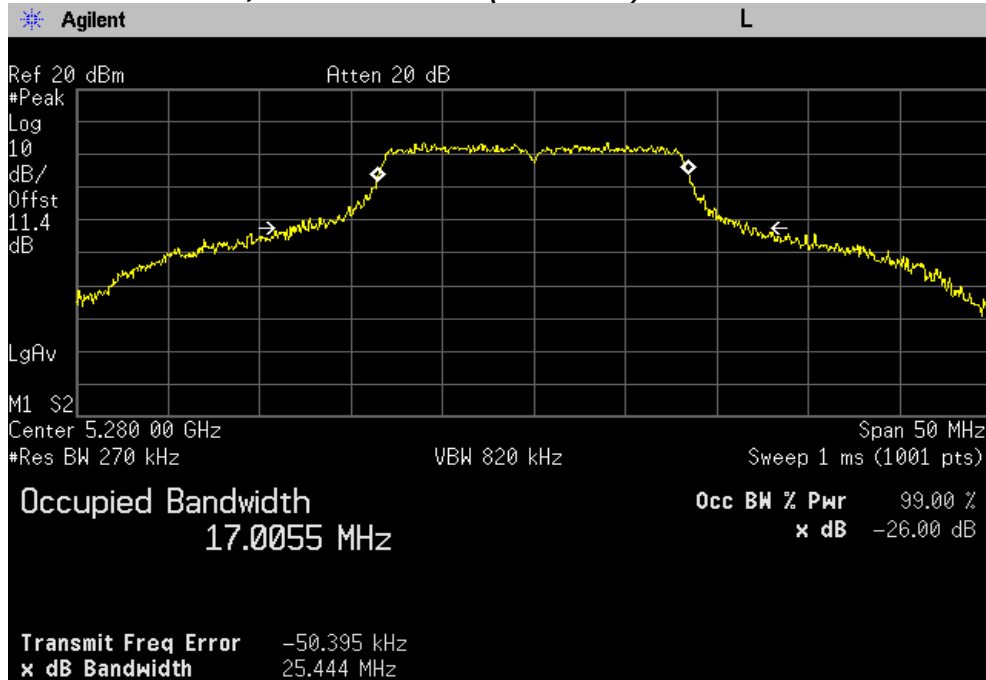

# PLOTS OF EMISSIONS

## 26 dB Bandwidth, Highest Channel (5320 MHz)

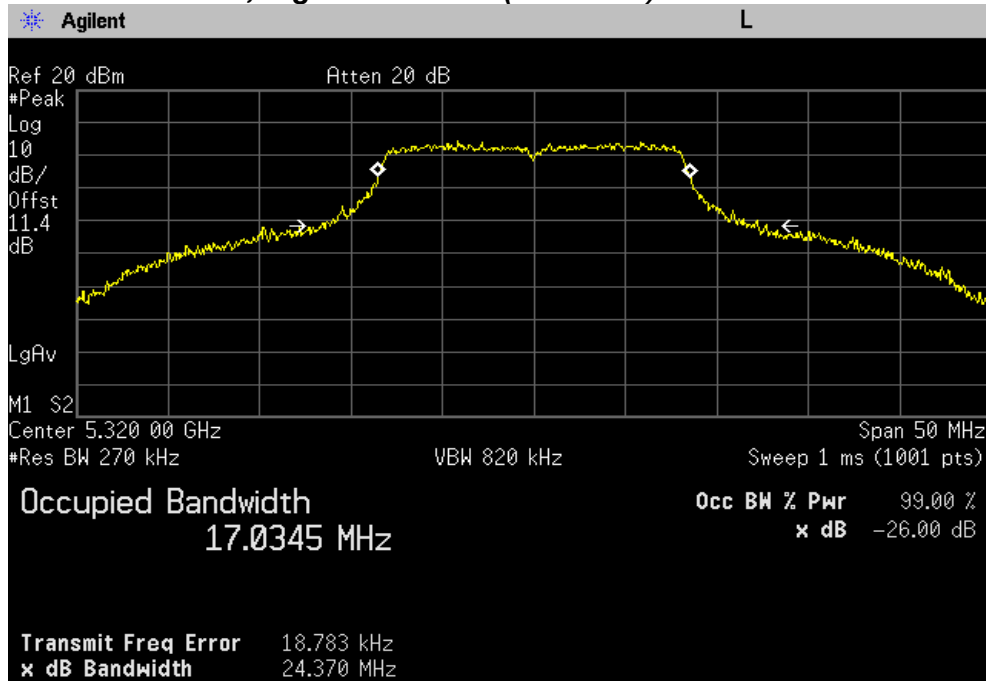

## Chain 1

## 26 dB Bandwidth, Lowest Channel (5260 MHz)

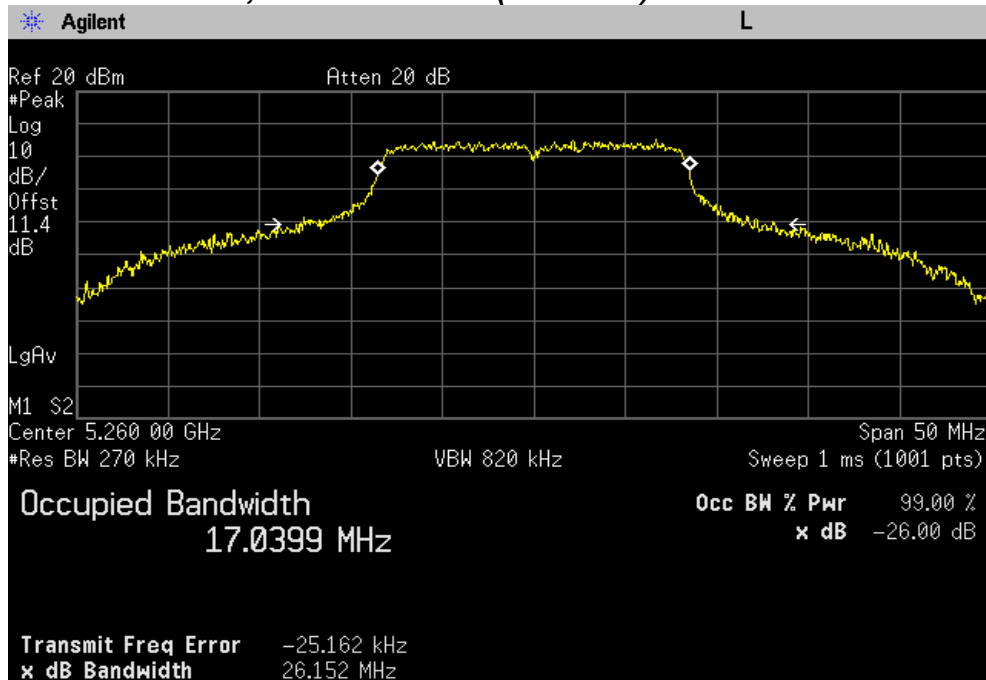

# PLOTS OF EMISSIONS

## 26 dB Bandwidth, Middle Channel (5280 MHz)

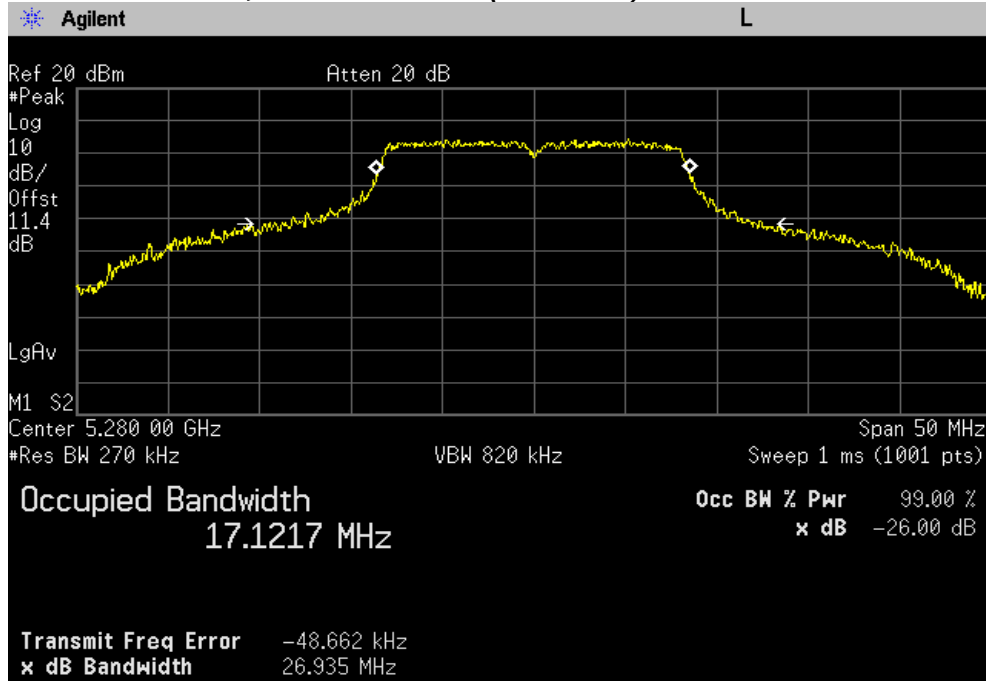

## 26 dB Bandwidth, Highest Channel (5320 MHz)

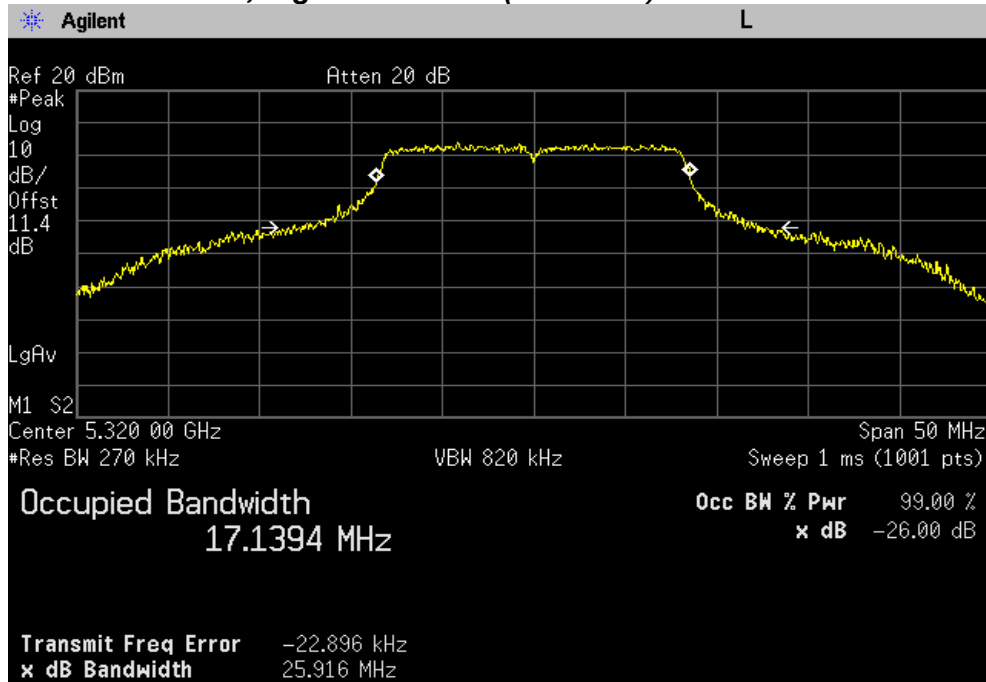



# PLOTS OF EMISSIONS

## 802.11n(20 MHz) mode

### Chain 0

#### **26 dB Bandwidth, Lowest Channel (5260 MHz)**

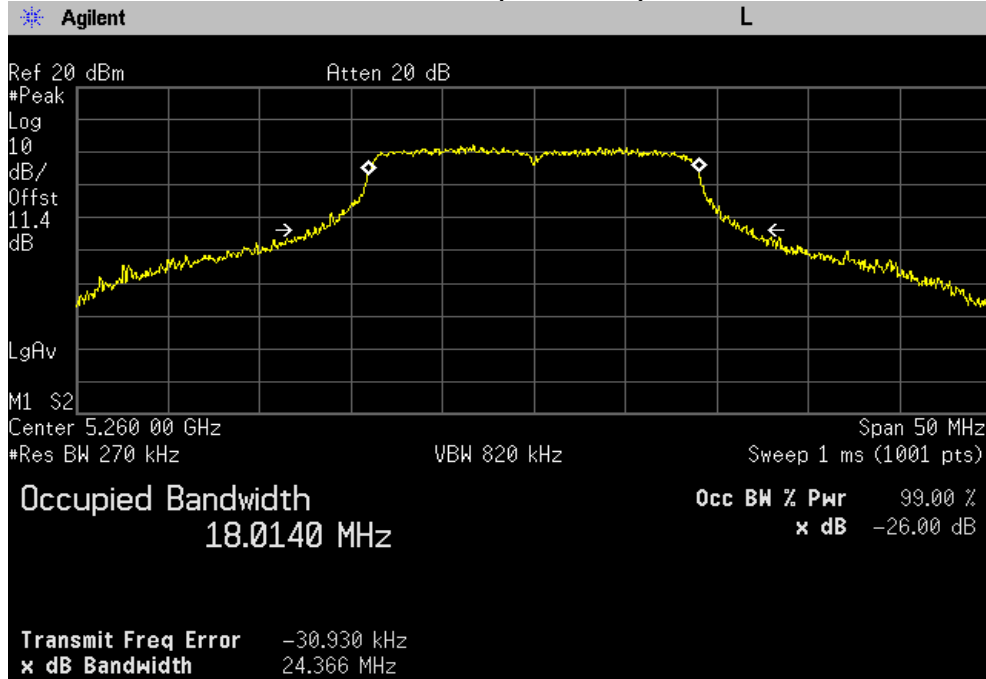

#### **26 dB Bandwidth, Middle Channel (5280 MHz)**

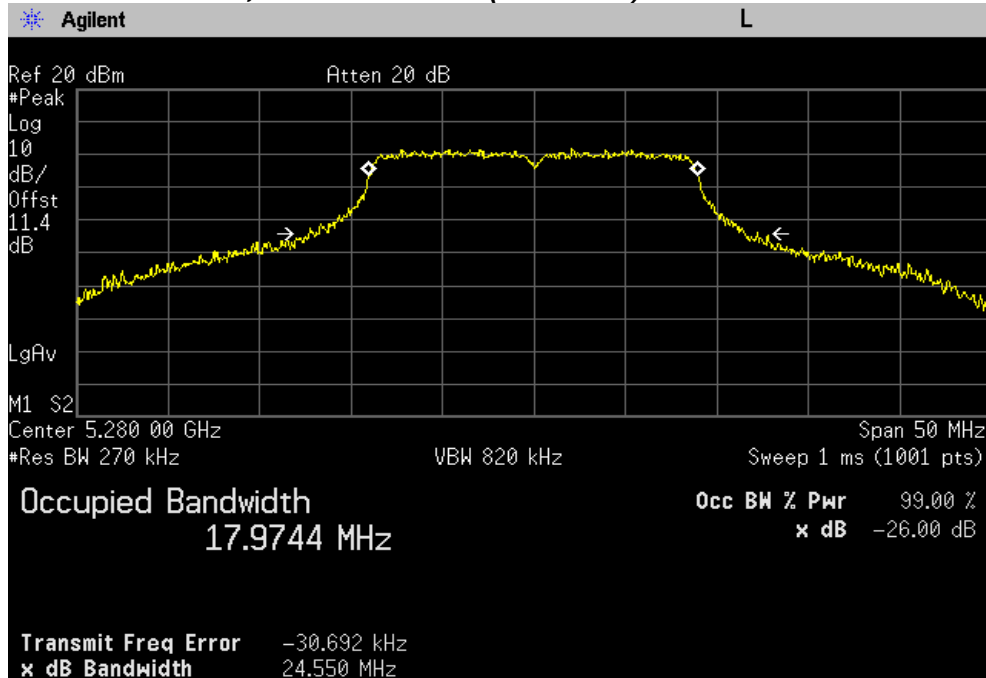

# PLOTS OF EMISSIONS

## 26 dB Bandwidth, Highest Channel (5320 MHz)

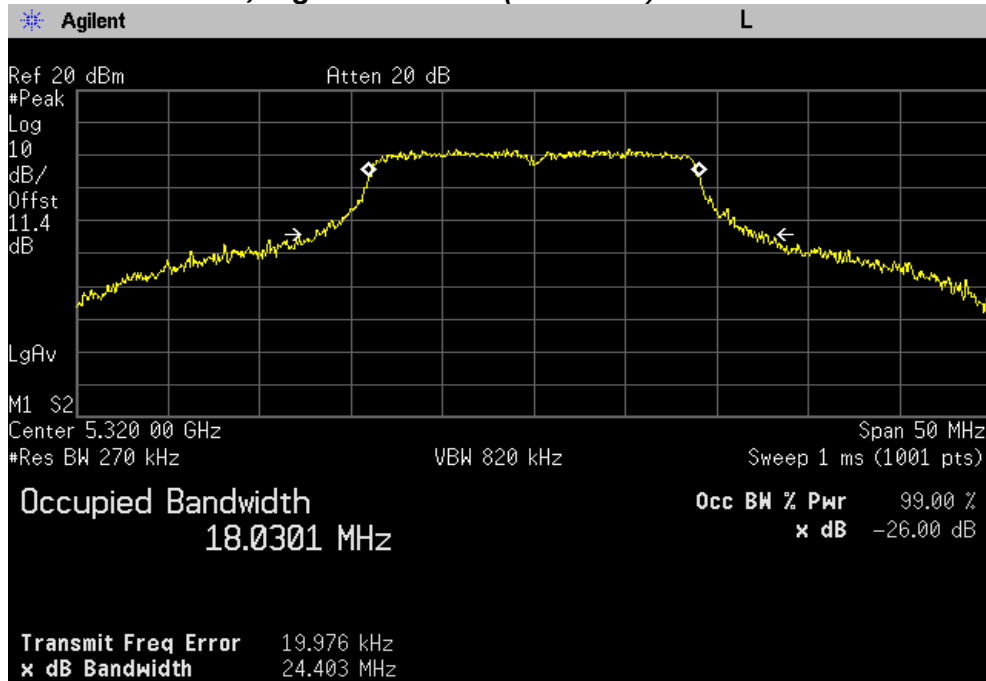

## Chain 1

## 26 dB Bandwidth, Lowest Channel (5260 MHz)

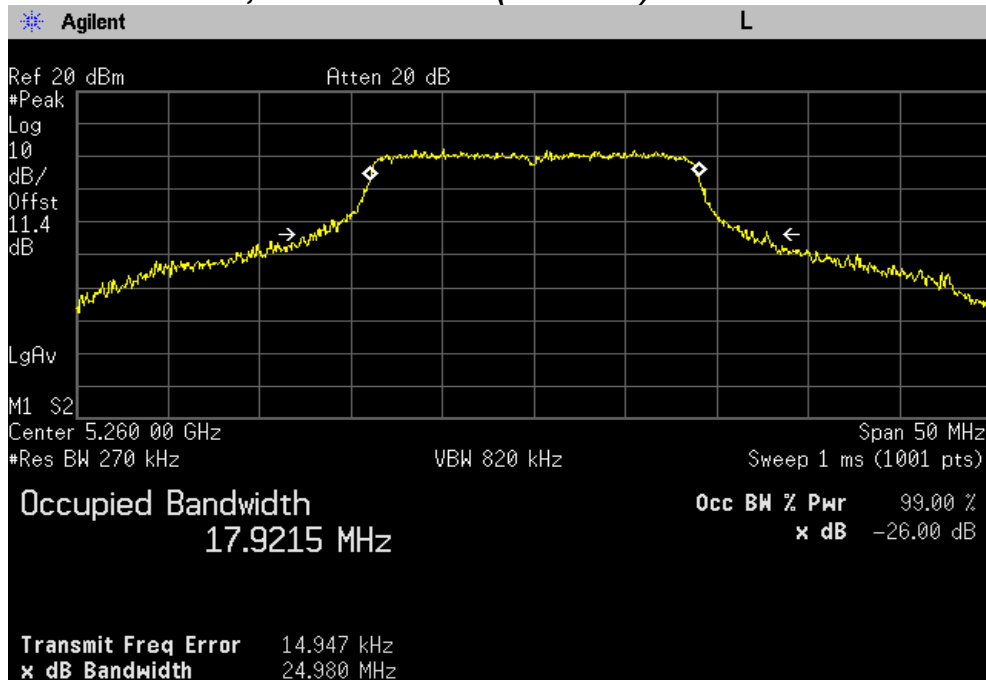

# PLOTS OF EMISSIONS

## 26 dB Bandwidth, Middle Channel (5280 MHz)

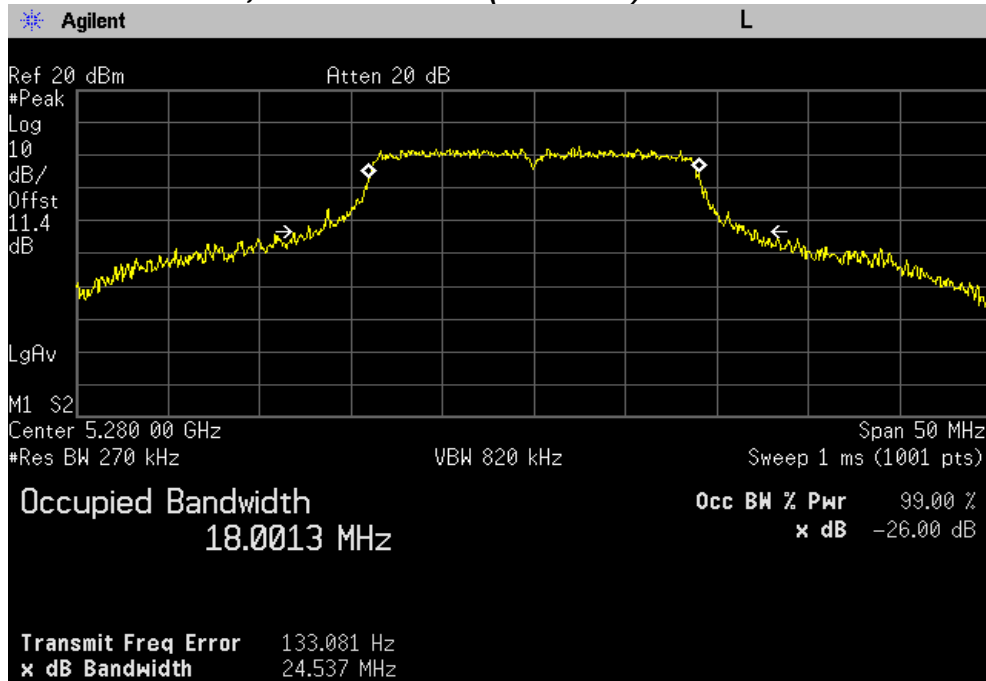

## 26 dB Bandwidth, Highest Channel (5320 MHz)

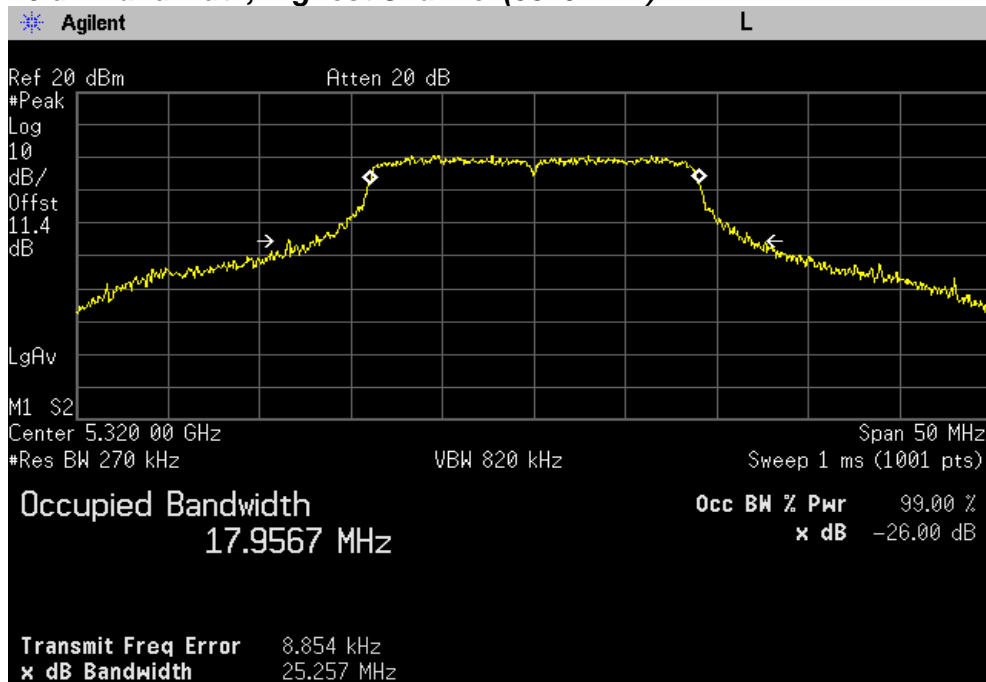

# PLOTS OF EMISSIONS

## 802.11n(40 MHz) mode

### Chain 0

#### **26 dB Bandwidth, Lowest Channel (5270 MHz)**

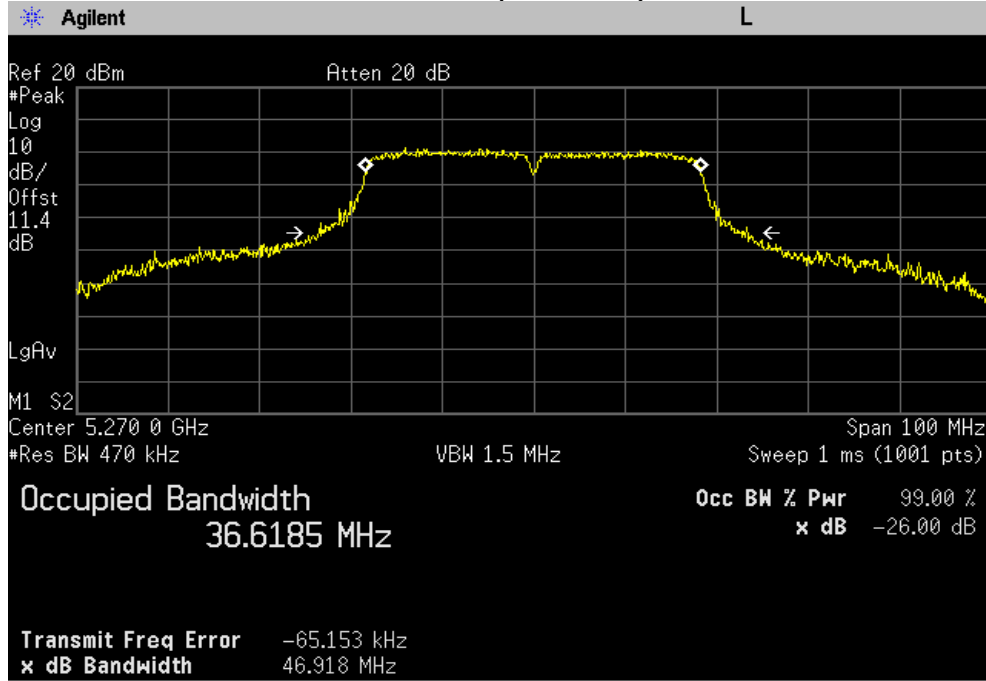

#### **26 dB Bandwidth, Highest Channel (5310 MHz)**

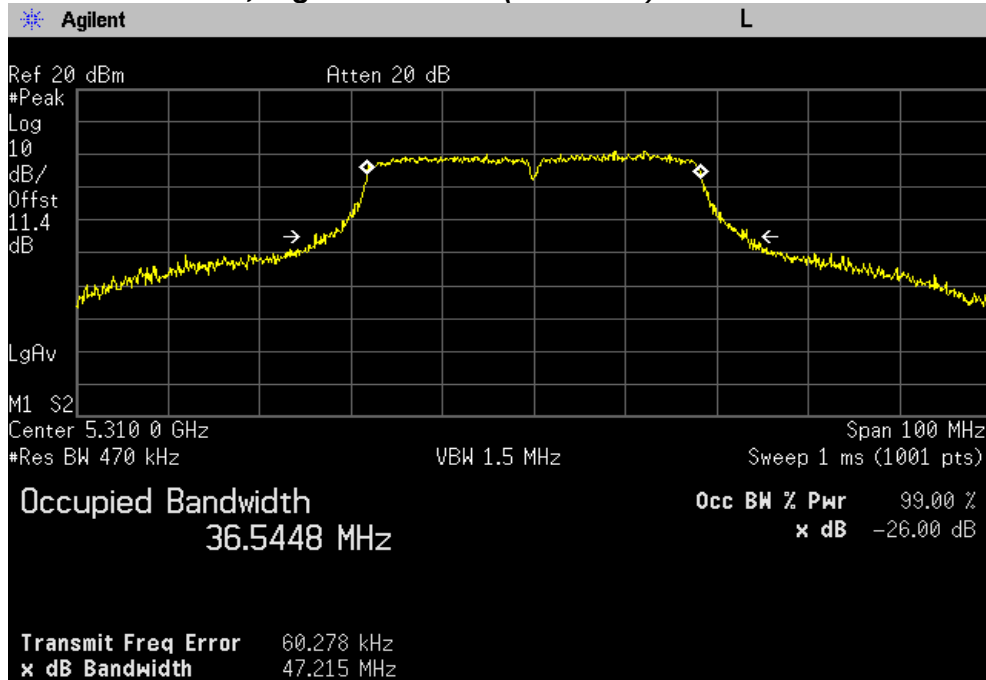

# PLOTS OF EMISSIONS

## Chain 1

### 26 dB Bandwidth, Lowest Channel (5270 MHz)

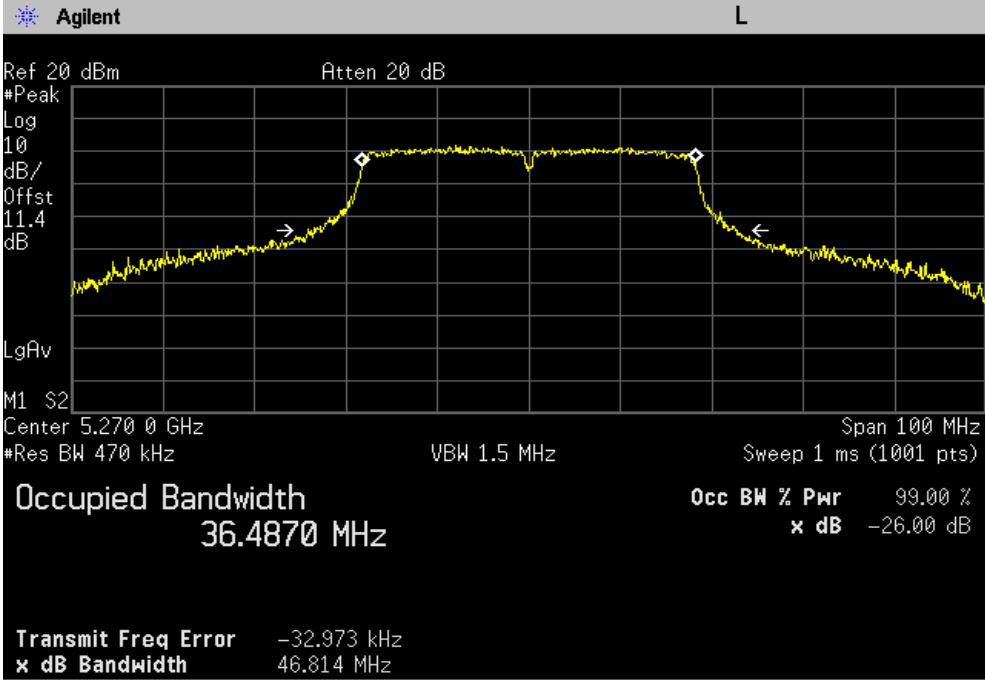

### 26 dB Bandwidth, Highest Channel (5310 MHz)

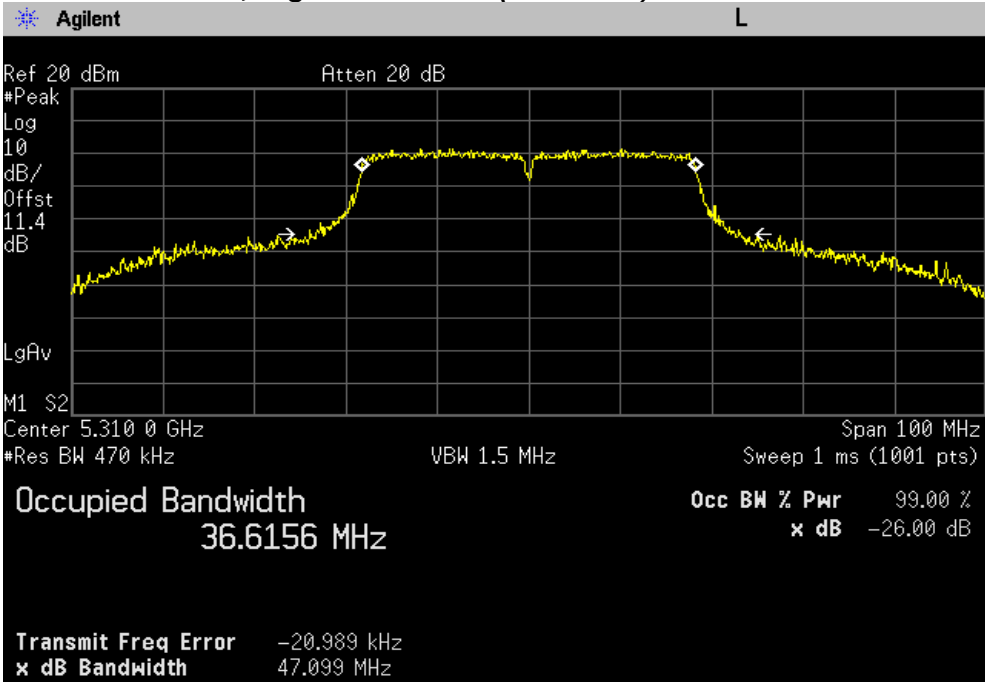

# TEST DATA

## 8.3.3 26 dB Bandwidth and 99 % Occupied bandwidth – Band III

### FCC §15.407(a), RSS-210 Issue 8, A9.2

### Test Mode : Set to Lowest channel, Middle channel and Highest channel

#### 802.11a mode

Channel	Frequency (MHz)	26 dB Bandwidth (MHz)		99% Occupied Bandwidth (MHz)	
		Chain 0	Chain 1	Chain 0	Chain 1
Low	5500	27.46	30.29	17.13	17.47
Middle	5580	27.28	30.03	17.23	17.43
High	5700	27.57	30.29	17.09	17.38

#### 802.11n (20 MHz) mode

Channel	Frequency (MHz)	26 dB Bandwidth (MHz)		99% Occupied Bandwidth (MHz)	
		Chain 0	Chain 1	Chain 0	Chain 1
Low	5500	25.99	26.43	18.08	17.89
Middle	5580	25.23	26.52	18.05	18.03
High	5700	26.08	26.84	18.02	18.00

#### 802.11n (40 MHz) mode

Channel	Frequency (MHz)	26 dB Bandwidth (MHz)		99% Occupied Bandwidth (MHz)	
		Chain 0	Chain 1	Chain 0	Chain 1
Low	5510	46.79	45.39	36.47	36.46
Middle	5590	45.90	45.71	36.50	36.35
High	5670	46.66	46.81	36.44	36.43

# PLOTS OF EMISSIONS

## 802.11a mode

### Chain 0

#### 26 dB Bandwidth, Lowest Channel (5500 MHz)

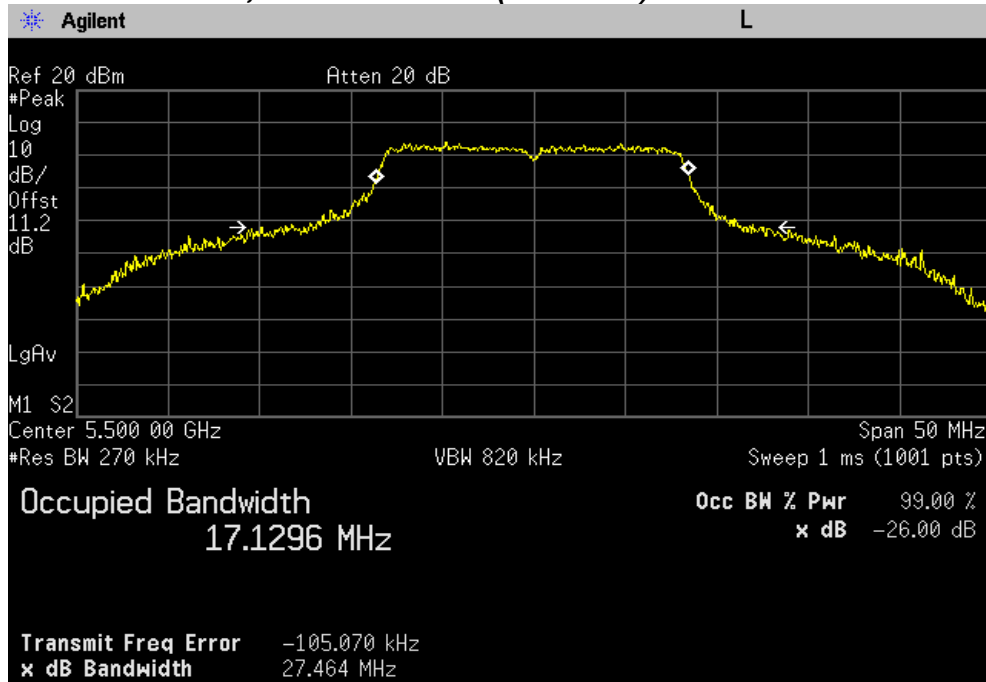

#### 26 dB Bandwidth, Middle Channel (5580 MHz)

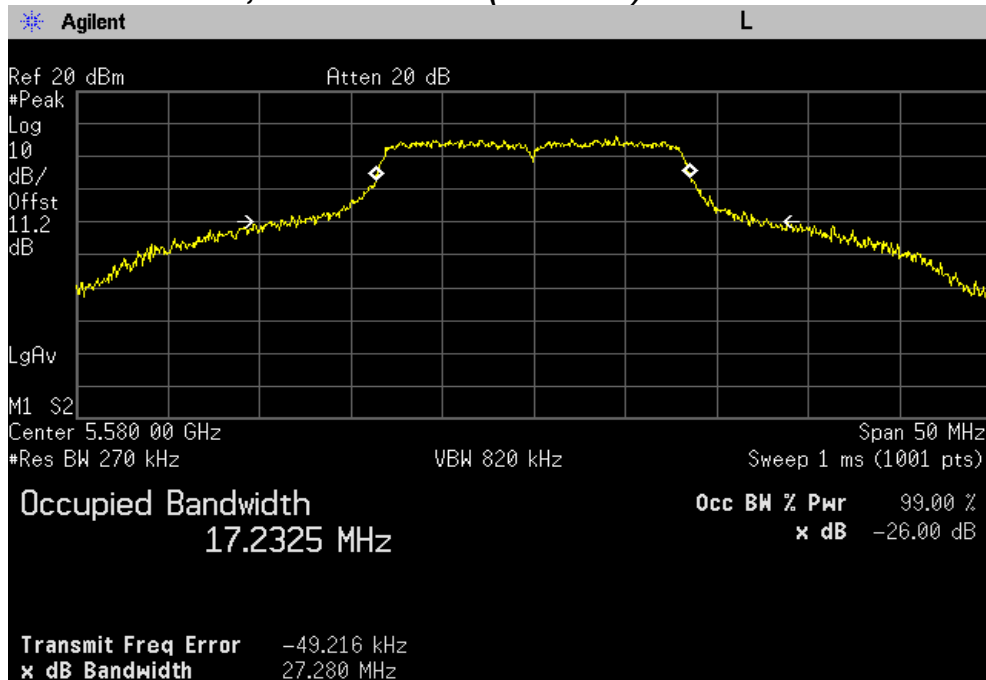

# PLOTS OF EMISSIONS

## 26 dB Bandwidth, Highest Channel (5700 MHz)

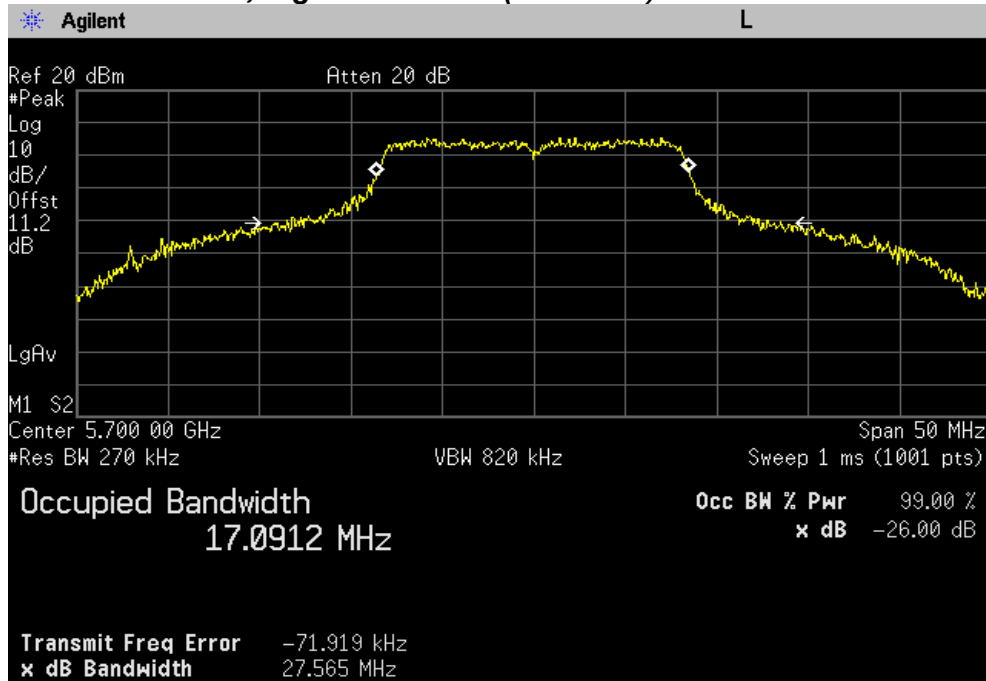

## Chain 1

## 26 dB Bandwidth, Lowest Channel (5500 MHz)

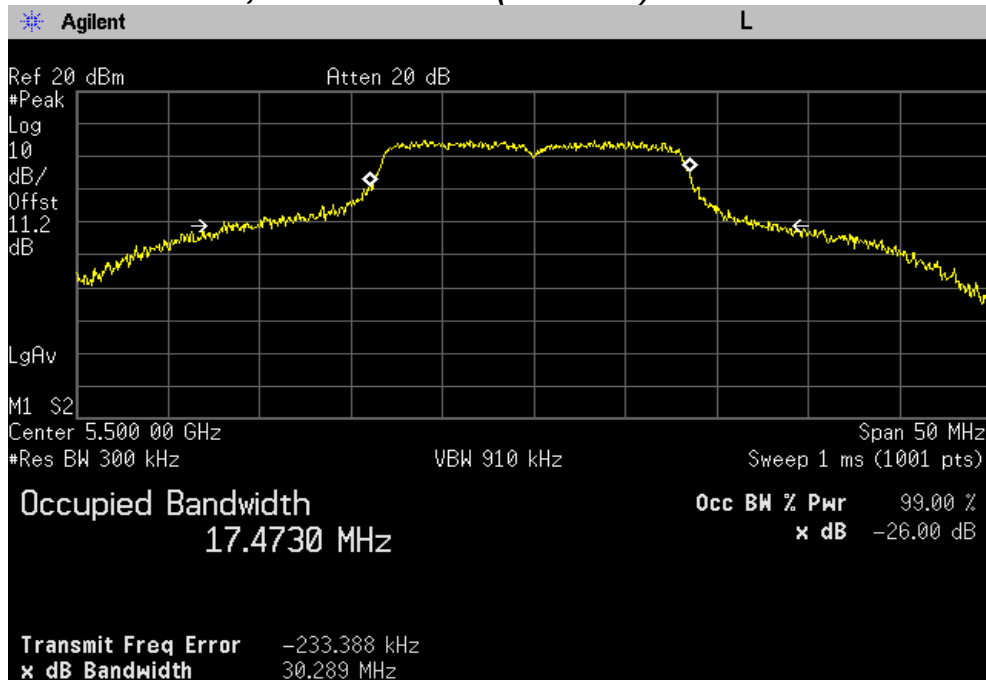



# PLOTS OF EMISSIONS

## 26 dB Bandwidth, Middle Channel (5580 MHz)

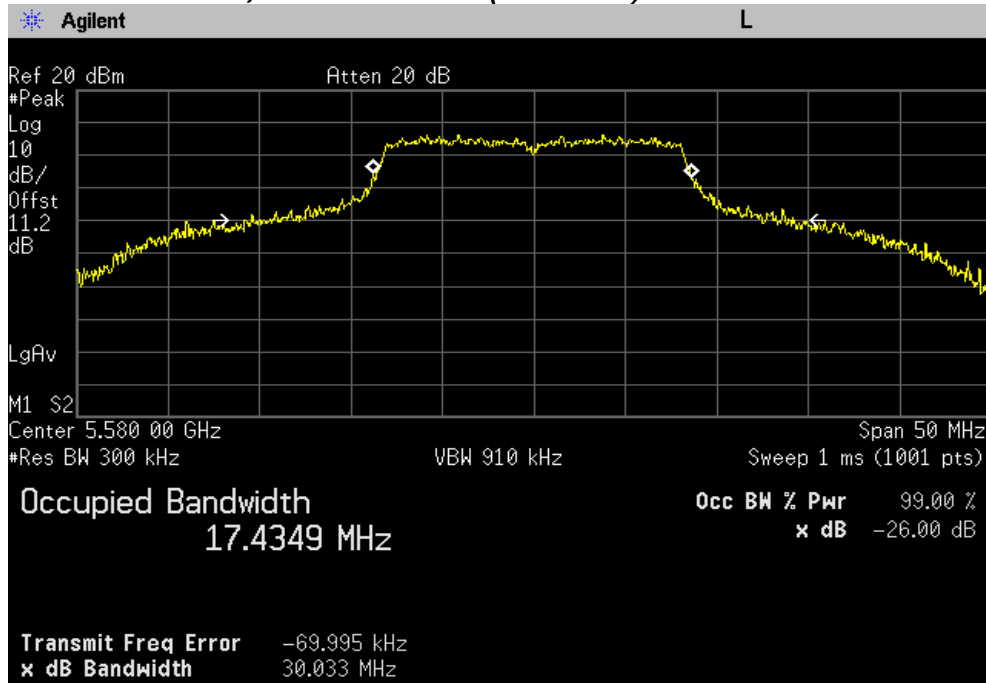

## 26 dB Bandwidth, Highest Channel (5700 MHz)

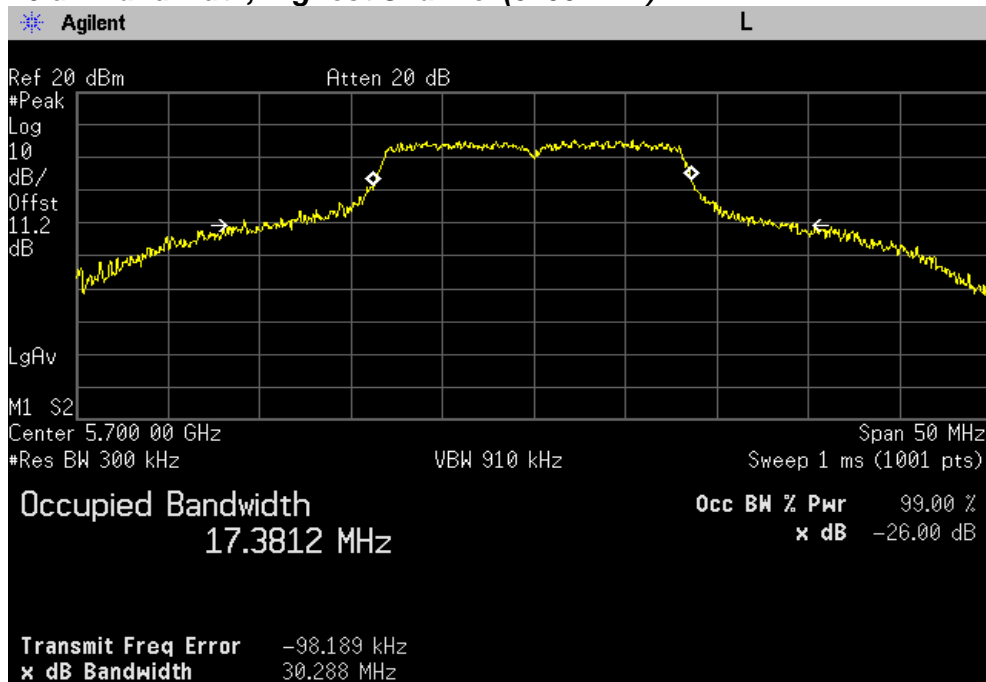

# PLOTS OF EMISSIONS

## 802.11n(20 MHz) mode

### Chain 0

#### **26 dB Bandwidth, Lowest Channel (5500 MHz)**

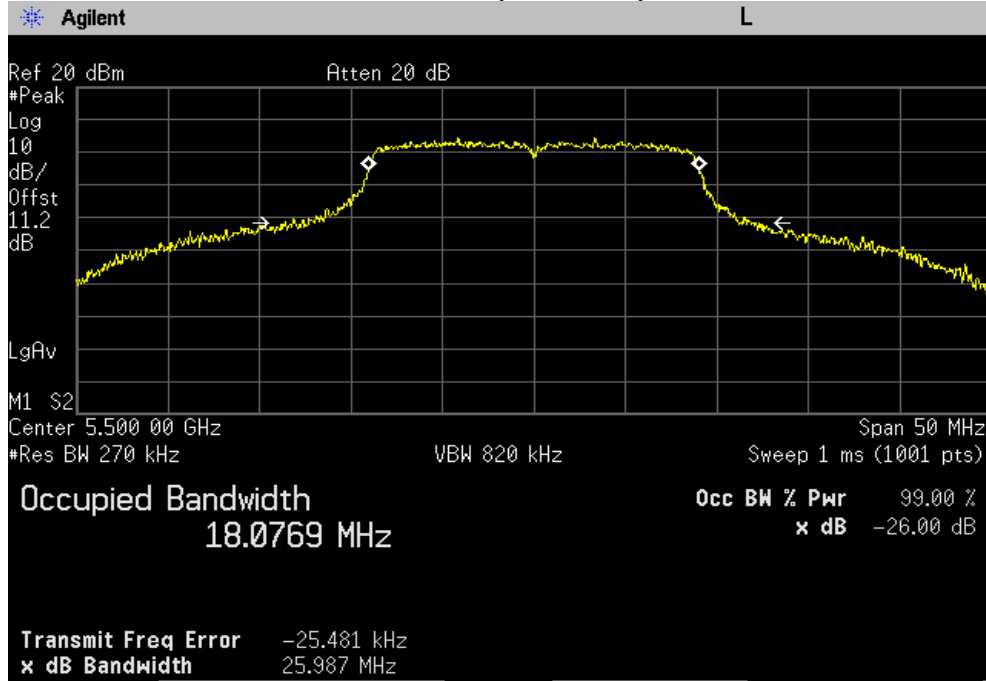

#### **26 dB Bandwidth, Middle Channel (5580 MHz)**

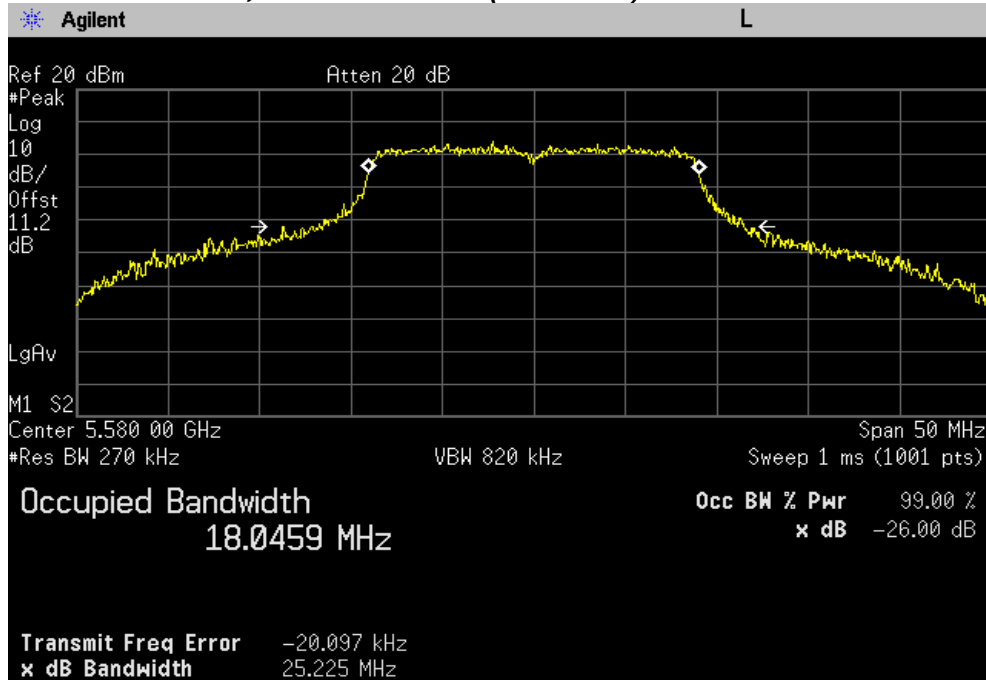

# PLOTS OF EMISSIONS

## 26 dB Bandwidth, Highest Channel (5700 MHz)

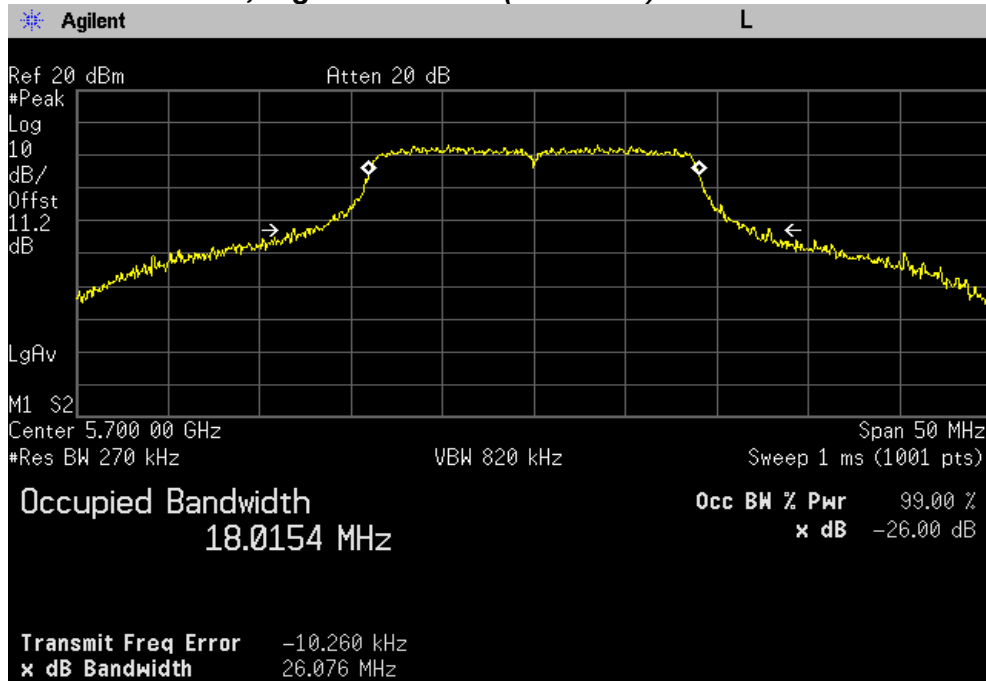

## Chain 1

## 26 dB Bandwidth, Lowest Channel (5500 MHz)

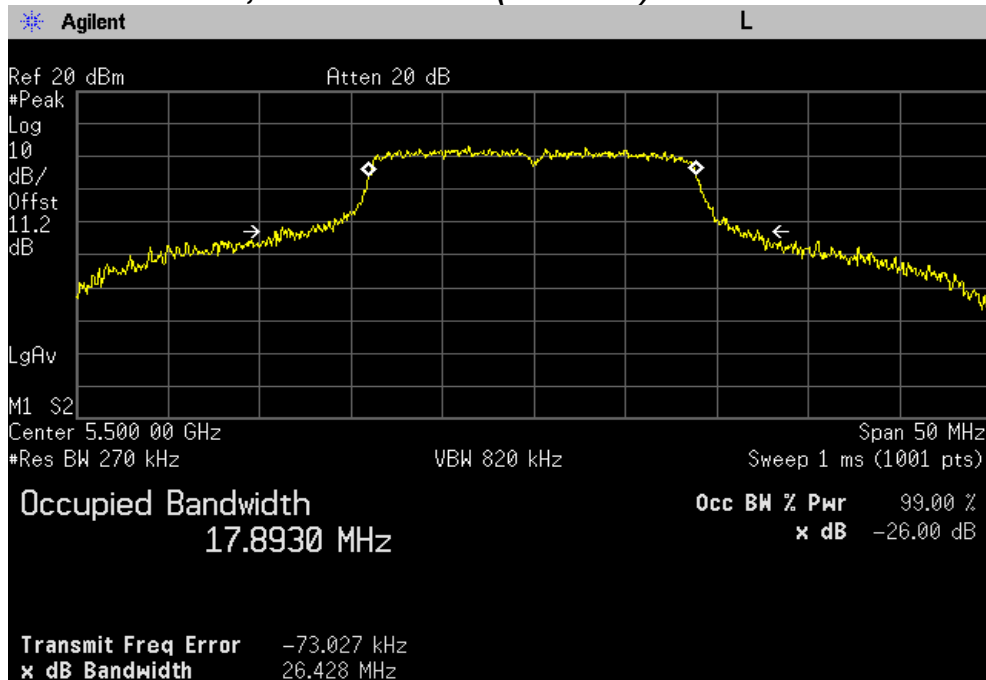

# PLOTS OF EMISSIONS

## 26 dB Bandwidth, Middle Channel (5580 MHz)

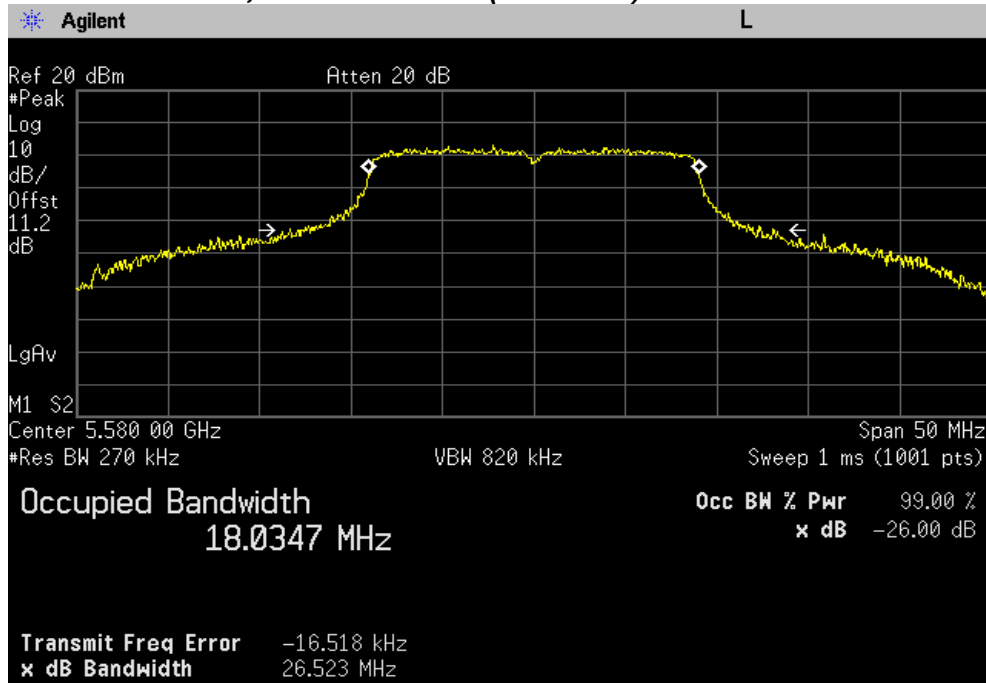

## 26 dB Bandwidth, Highest Channel (5700 MHz)

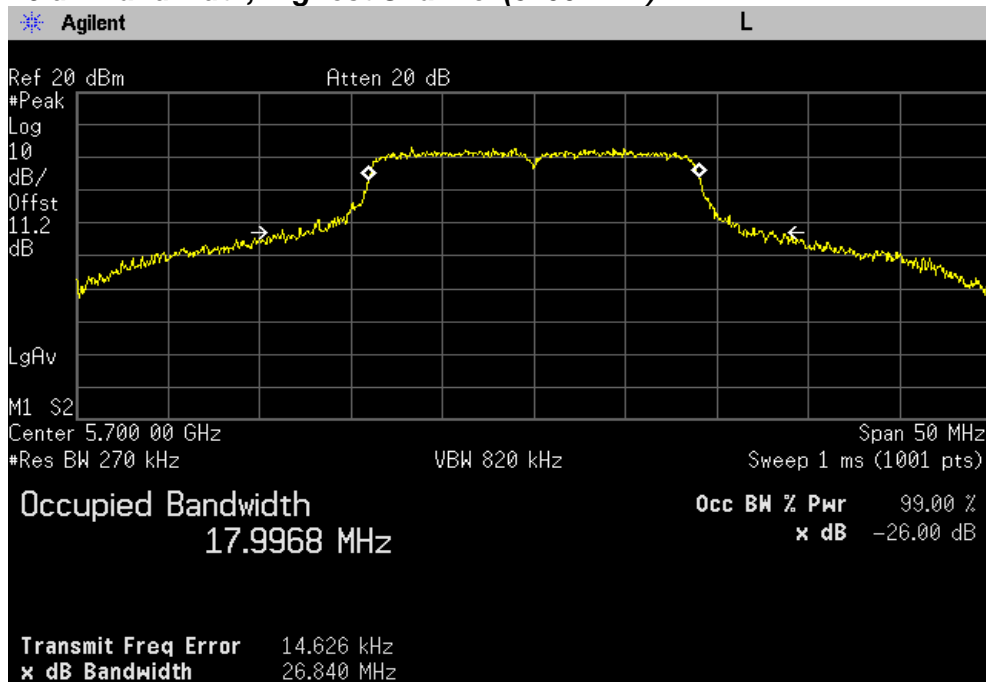

# PLOTS OF EMISSIONS

## 802.11n(40 MHz) mode

### Chain 0

#### **26 dB Bandwidth, Lowest Channel (5510 MHz)**

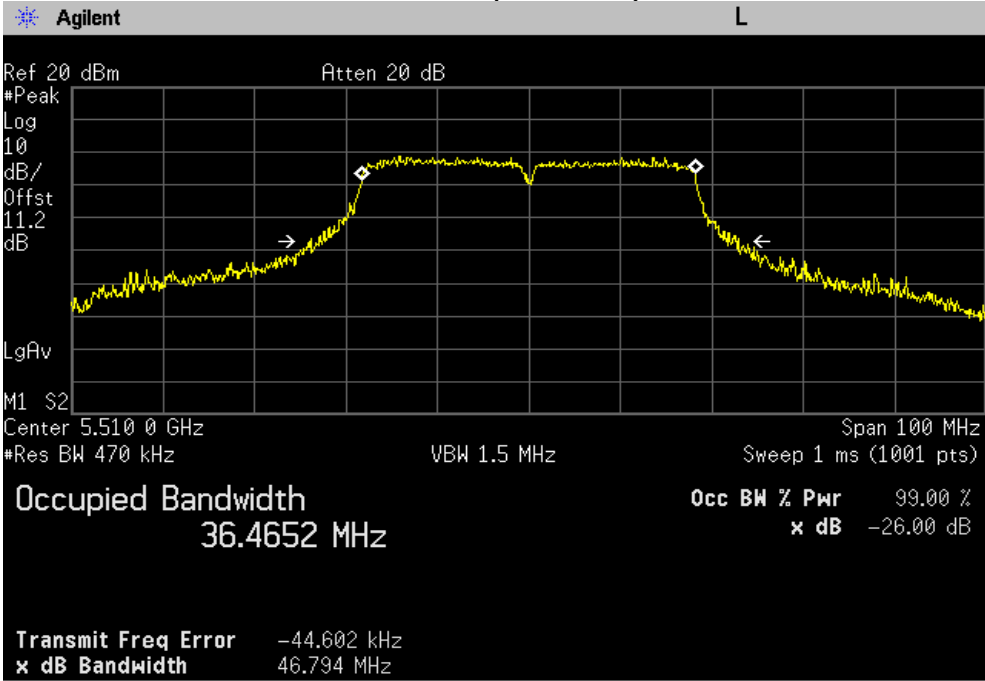

#### **26 dB Bandwidth, Middle Channel (5590 MHz)**

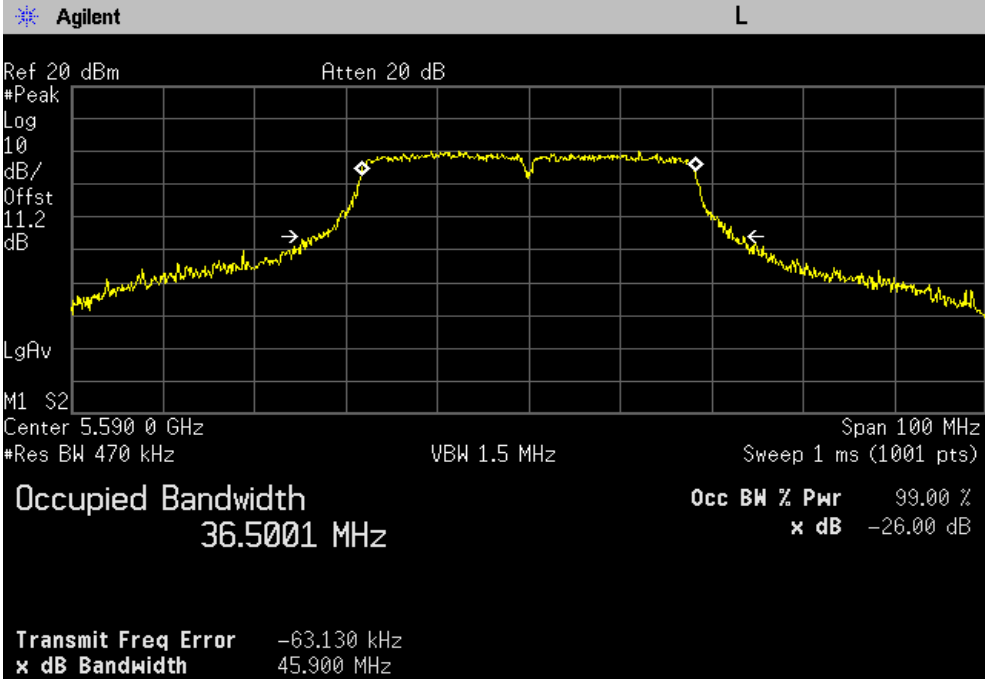

# PLOTS OF EMISSIONS

## 26 dB Bandwidth, Highest Channel (5670 MHz)

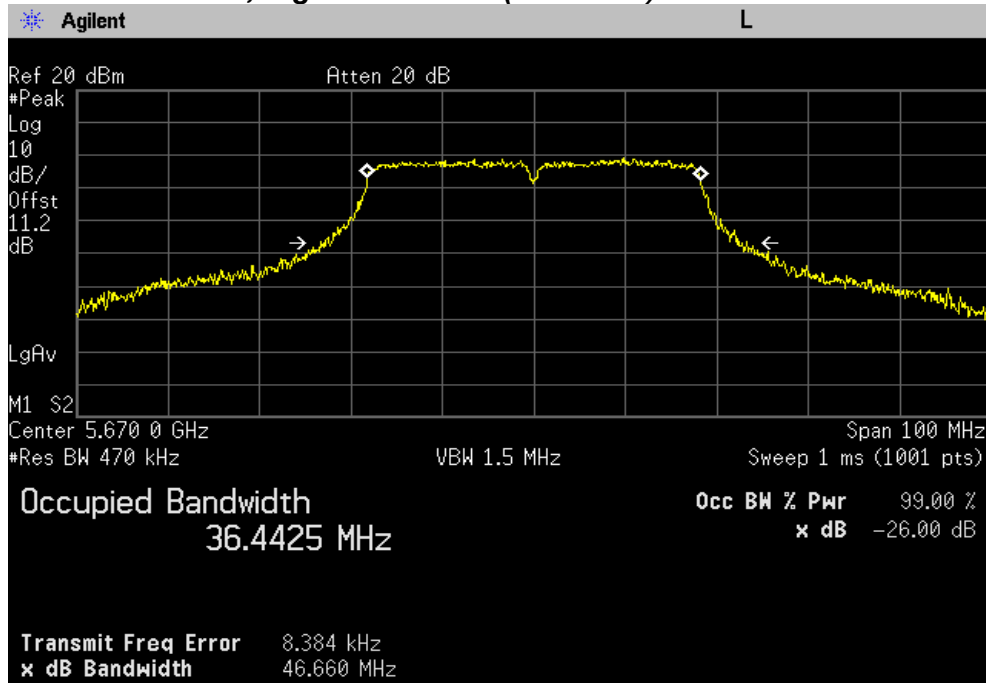

## Chain 1

## 26 dB Bandwidth, Lowest Channel (5510 MHz)

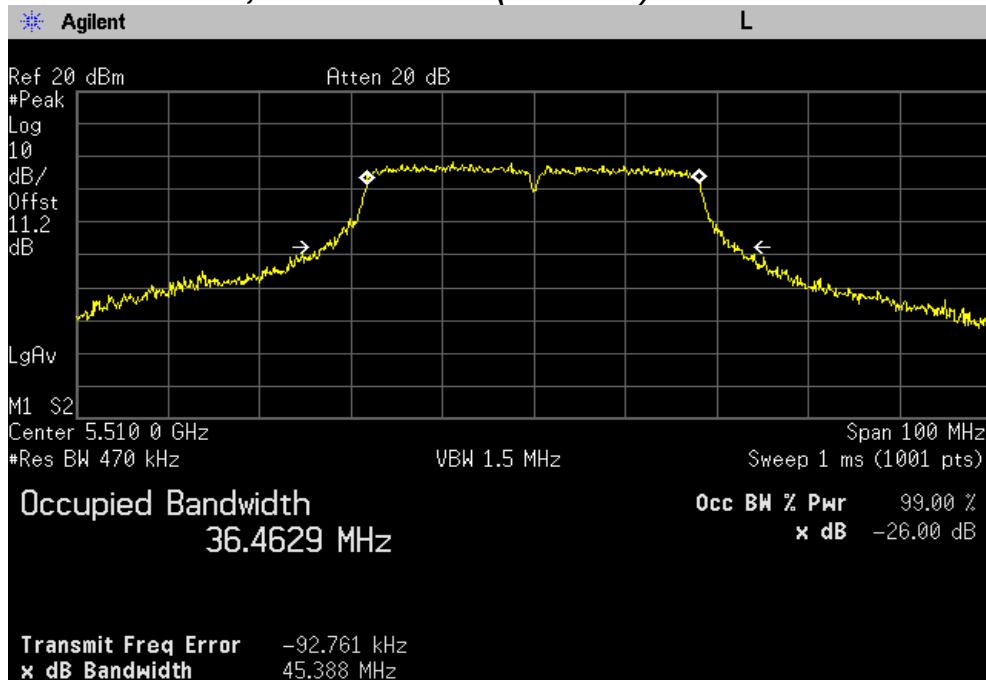

# PLOTS OF EMISSIONS

## 26 dB Bandwidth, Middle Channel (5590 MHz)

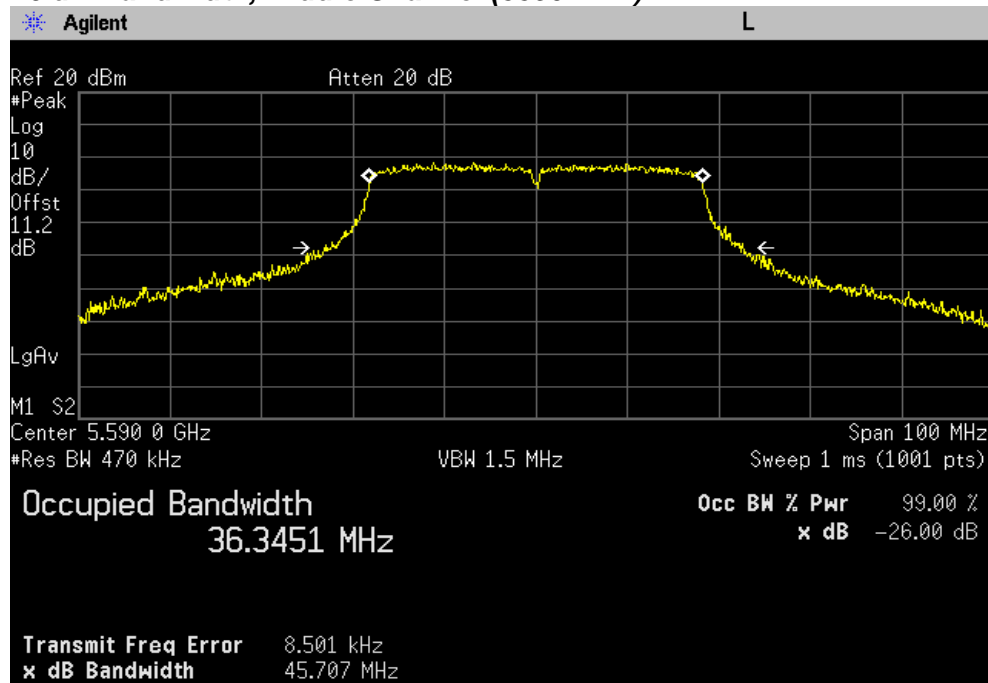

## 26 dB Bandwidth, Highest Channel (5670 MHz)

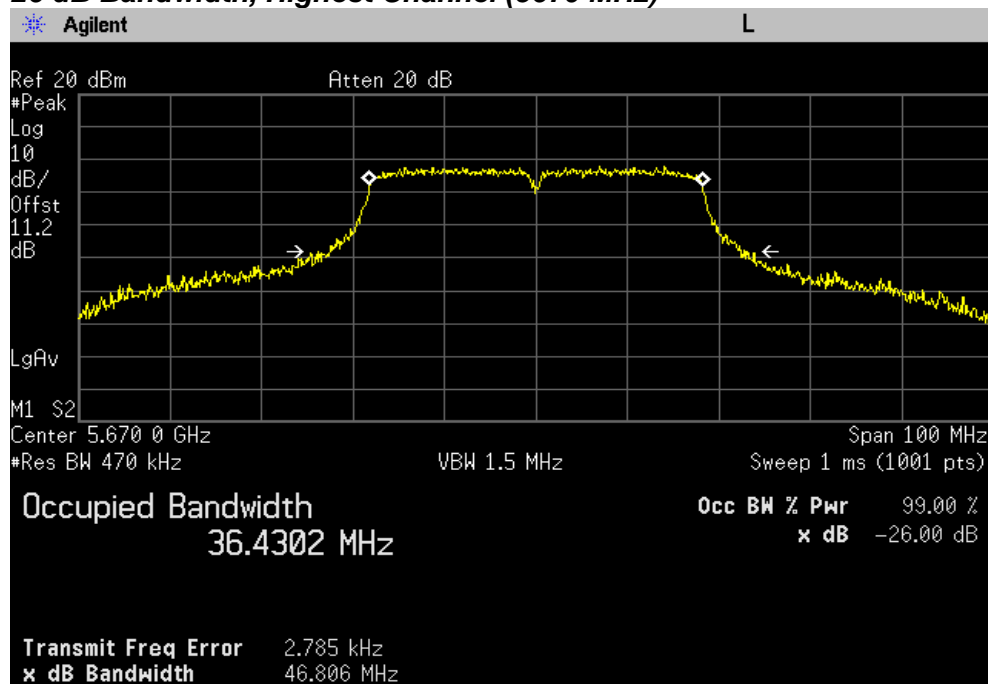

# TEST DATA

## 8.4 Maximum Peak Output Power

### 8.4.1 Maximum Peak Output Power – Band I

FCC §15.407(a), RSS-210 Issue 8, A9.2

Test Mode : Set to Lowest channel, Middle channel and Highest channel

#### 802.11a

Channel	Frequency(MHz)	Peak Output Power (dBm)		Limit (dBm)
		Chain 0	Chain 1	
Low	5180	11.44	12.89	17.0
Middle	5200	11.90	12.36	17.0
High	5240	11.83	12.41	17.0

#### 802.11n(20 MHz)

Channel	Frequency (MHz)	Peak Output Power (dBm)		*Total Peak Power (dBm)	Limit (dBm)
		Chain 0	Chain 1		
Low	5180	10.10	10.70	13.42	17.0
Middle	5200	10.41	10.38	13.41	17.0
High	5240	10.30	10.00	13.16	17.0

#### 802.11n(40 MHz)

Channel	Frequency (MHz)	Peak Output Power (dBm)		*Total Peak Power (dBm)	Limit (dBm)
		Chain 0	Chain 1		
Low	5190	10.18	10.46	13.33	17.0
High	5230	10.04	10.44	13.25	17.0



**Note:**

The following equation was used for spectrum offset:

$$\text{Spectrum offset (dB)} = \text{Attenuator (dB)} + \text{Cable Loss (dB)} + \text{SMA Type Connector Loss (dB)}$$

For the band 5.15~5.25 GHz, the maximum conducted output power over the frequency band of operation shall not exceed the lesser of **50 mW(17 dBm)** or  $4 \text{ dBm} + 10\log(26 \text{ dB Bandwidth})$

$$= 4 \text{ dBm} + 10\log(22.36) = 17.49 \text{ dBm}$$

**The maximum conducted output limit is 17 dBm.**

$$*\text{Total Peak power} = 10 \log [10^{(\text{Chain 0 Power}/10)} + 10^{(\text{Chain 1 Power}/10)}]$$

# PLOT OF TEST DATA

## 802.11a mode

### Chain 0

#### Maximum Peak Output Power, Lowest Channel (5180 MHz)

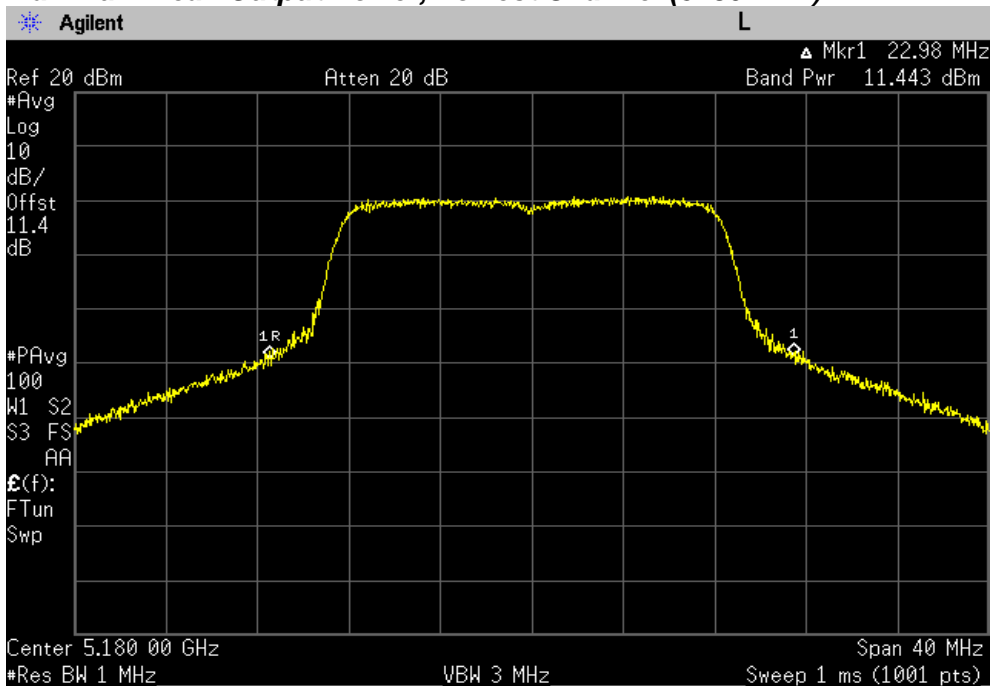

#### Maximum Peak Output Power, Middle Channel (5200 MHz)

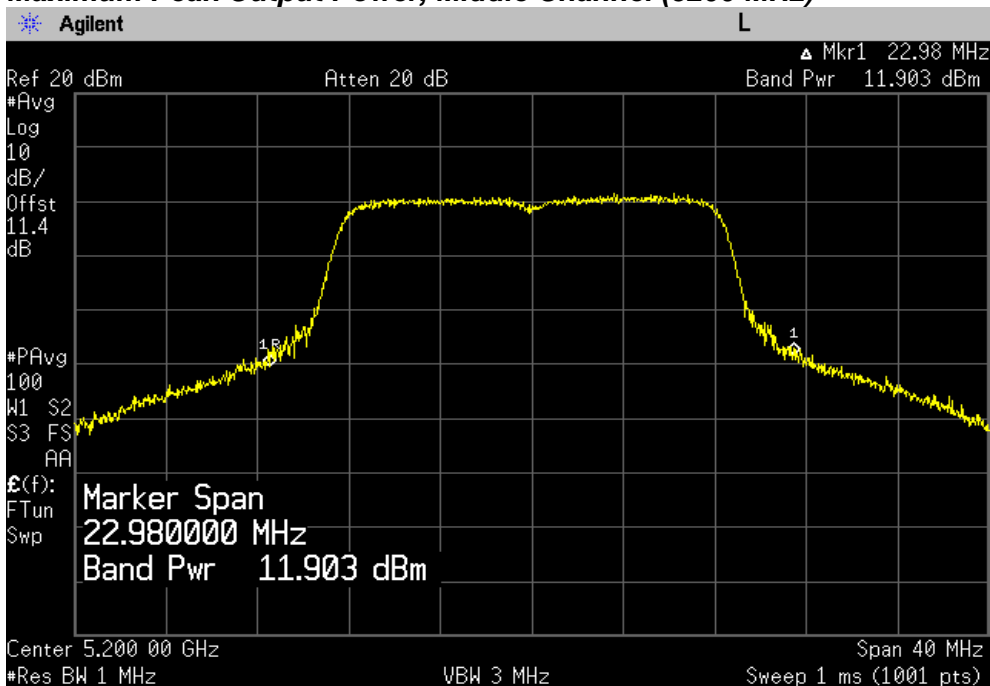

# PLOT OF TEST DATA

## Maximum Peak Output Power, Highest Channel (5240 MHz)

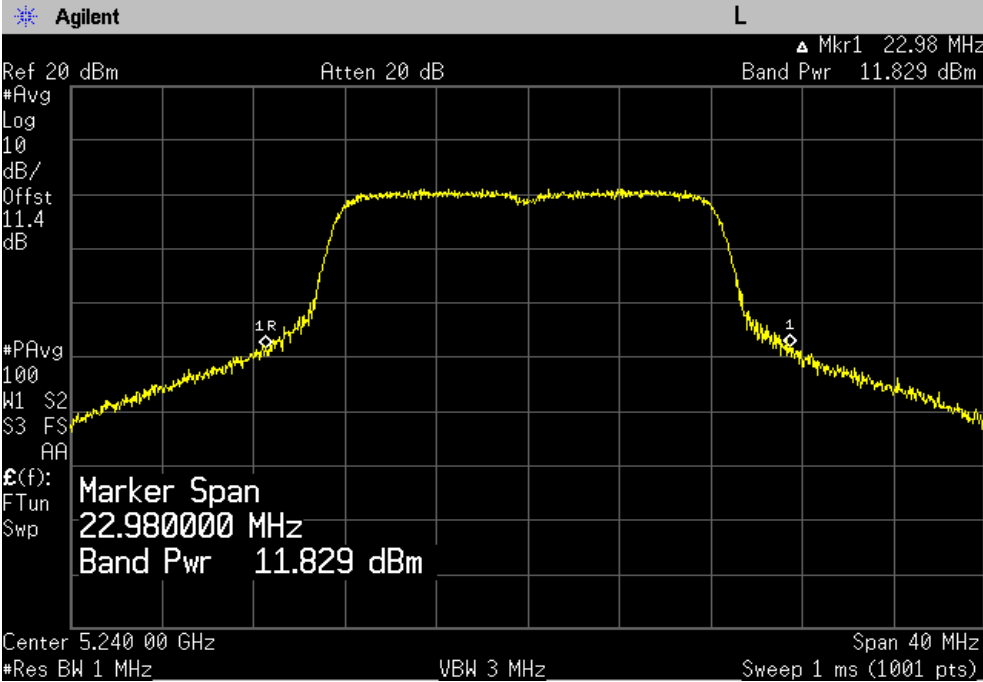

## Chain 1

## Maximum Peak Output Power, Lowest Channel (5180 MHz)

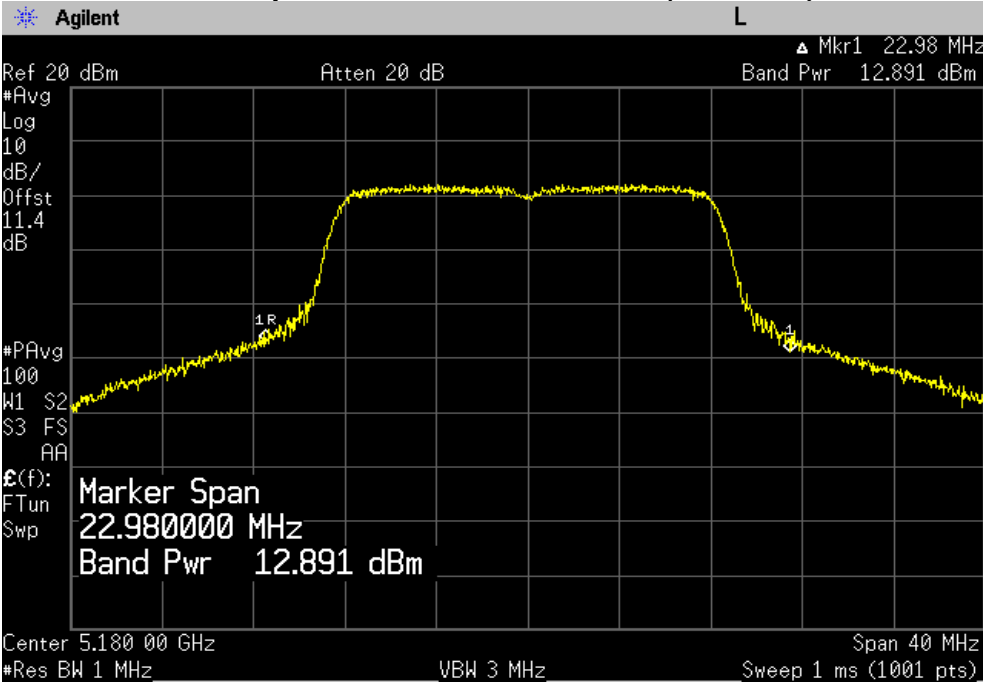

# PLOT OF TEST DATA

**Maximum Peak Output Power, Middle Channel (5200 MHz)**

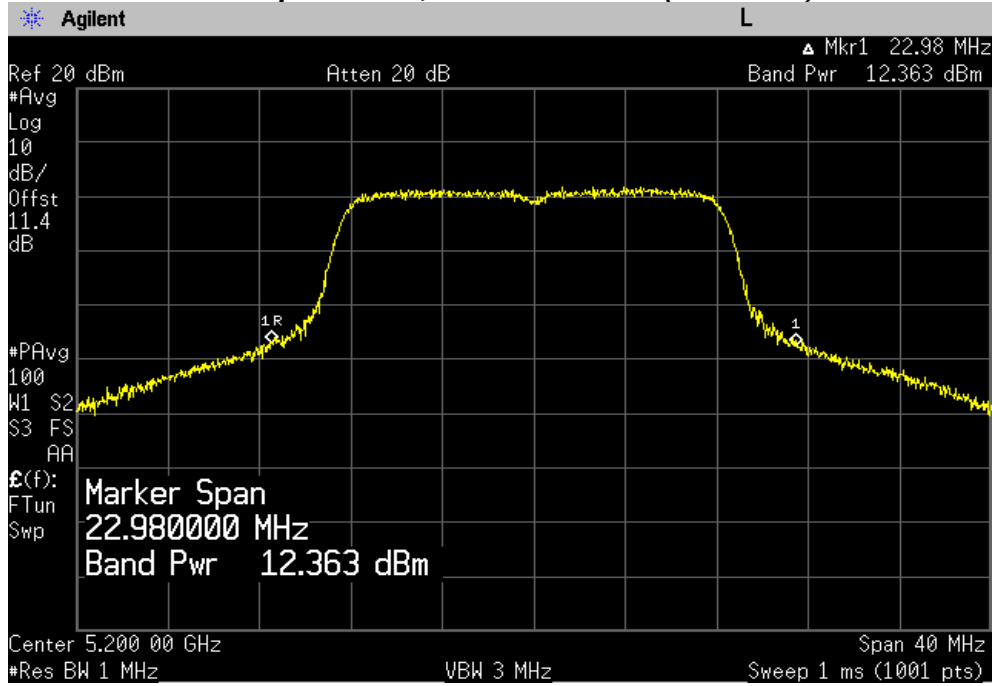

**Maximum Peak Output Power, Highest Channel (5240 MHz)**

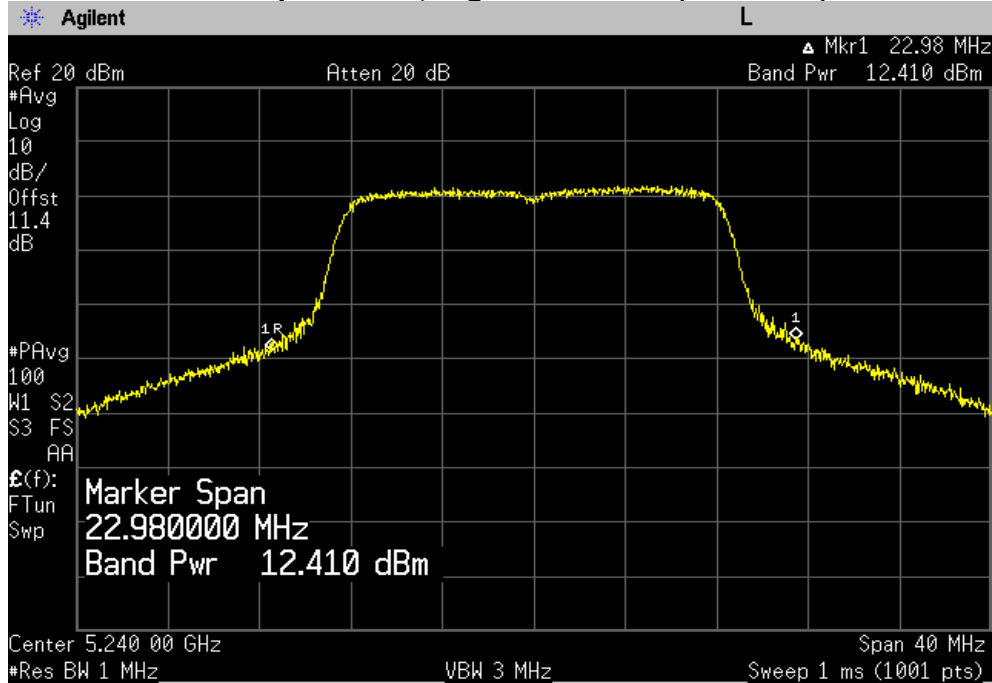

# PLOT OF TEST DATA

**802.11n(20 MHz) mode**

**Chain 0**

**Maximum Peak Output Power, Lowest Channel (5180 MHz)**

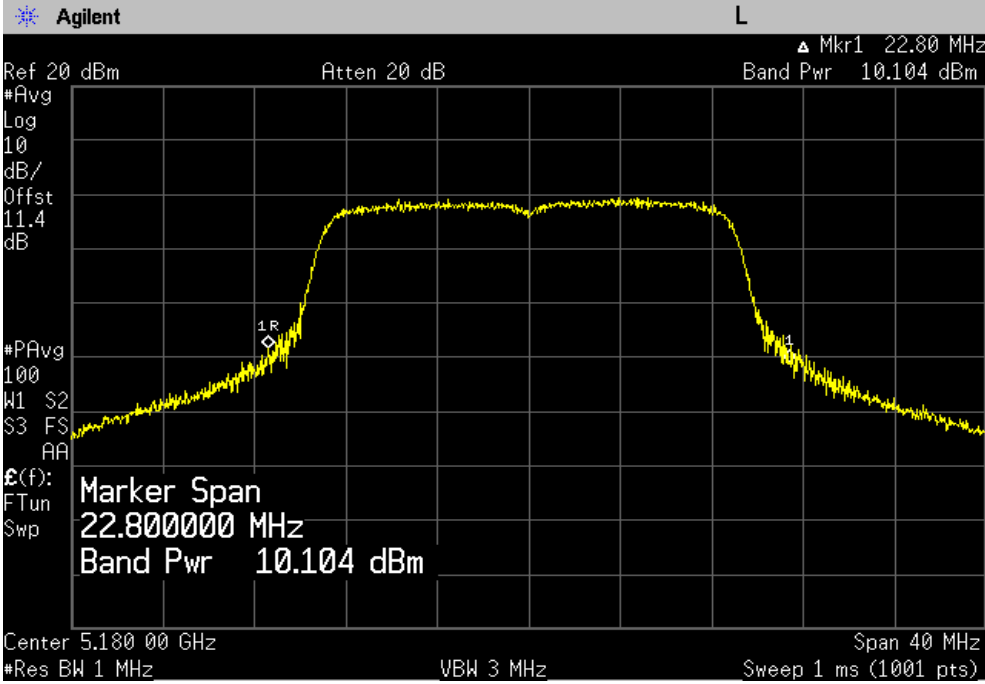

**Maximum Peak Output Power, Middle Channel (5200 MHz)**

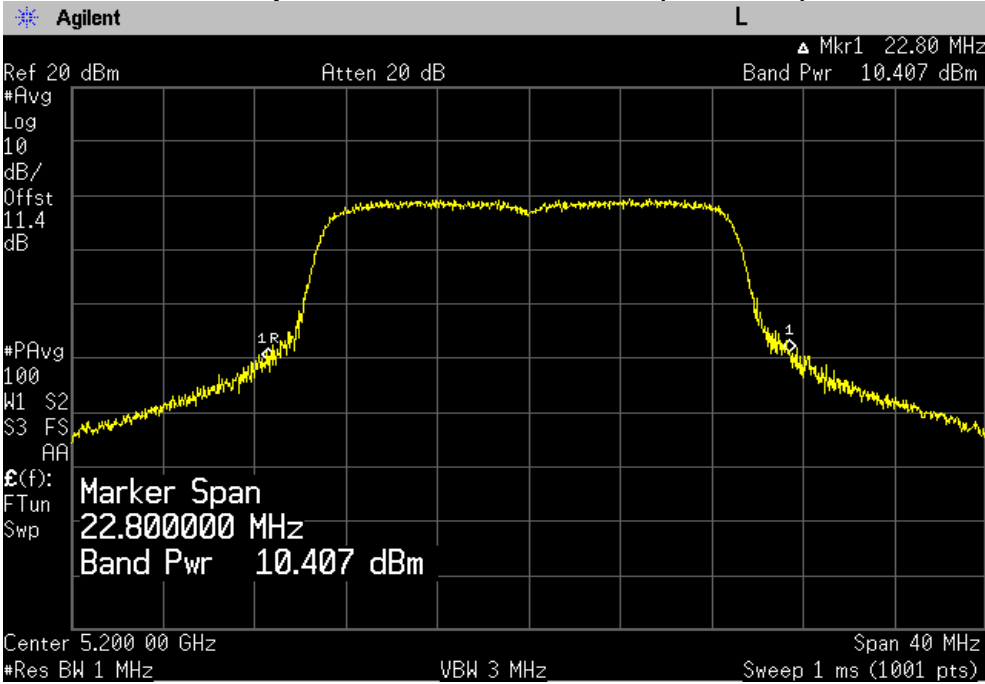

# PLOT OF TEST DATA

## Maximum Peak Output Power, Highest Channel (5240 MHz)

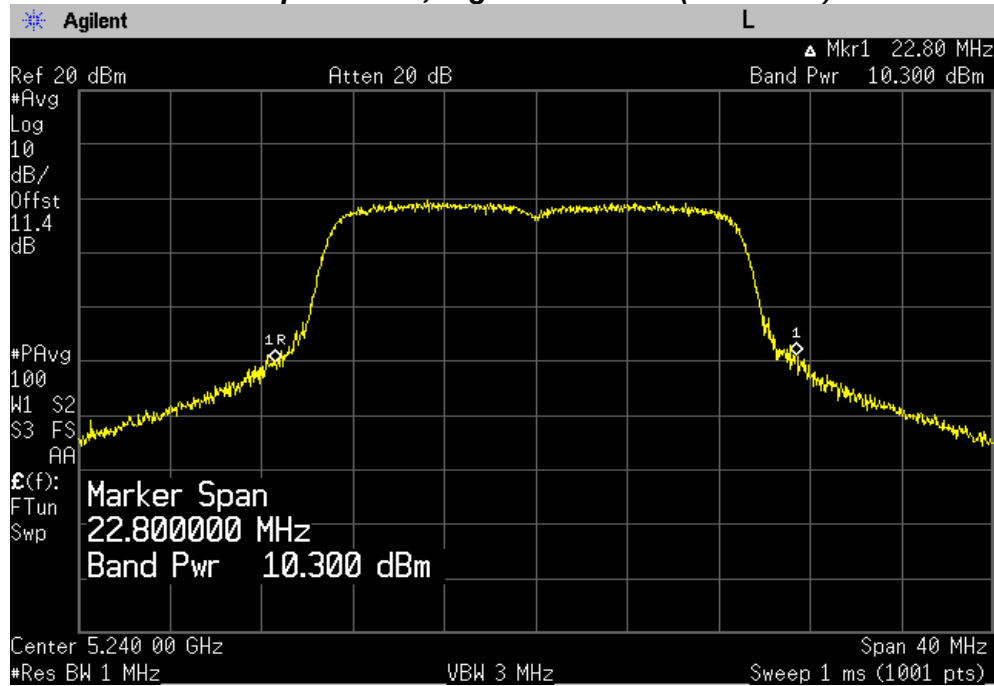

## Chain 1

## Maximum Peak Output Power, Lowest Channel (5180 MHz)

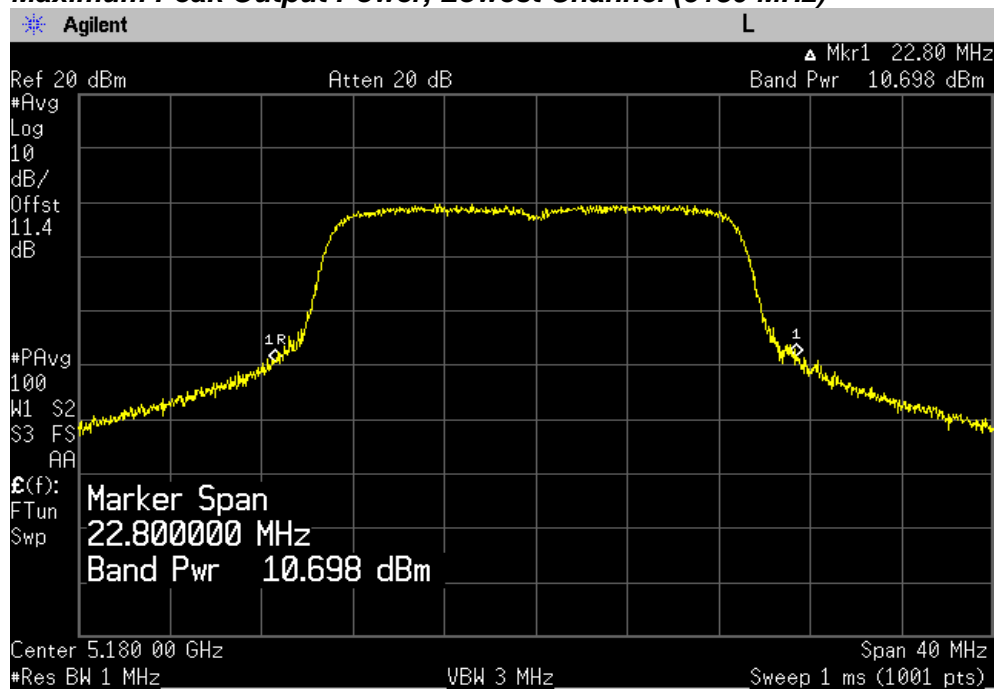

# PLOT OF TEST DATA

**Maximum Peak Output Power, Middle Channel (5200 MHz)**

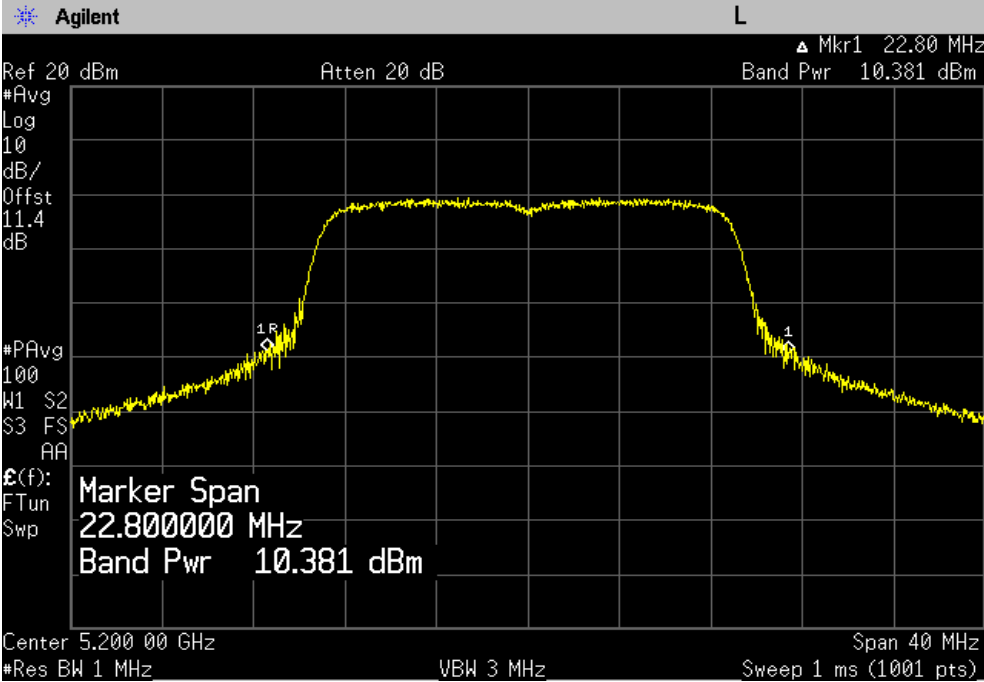

**Maximum Peak Output Power, Highest Channel (5240 MHz)**

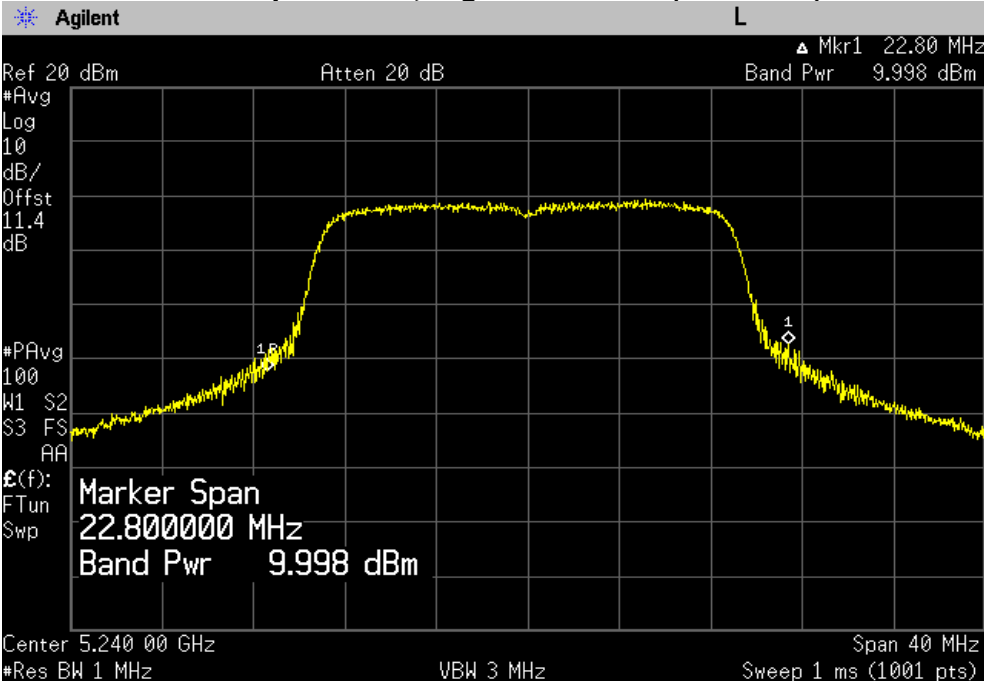

# PLOT OF TEST DATA

## 802.11n(40 MHz) mode

### Chain 0

#### Maximum Peak Output Power, Lowest Channel (5190 MHz)

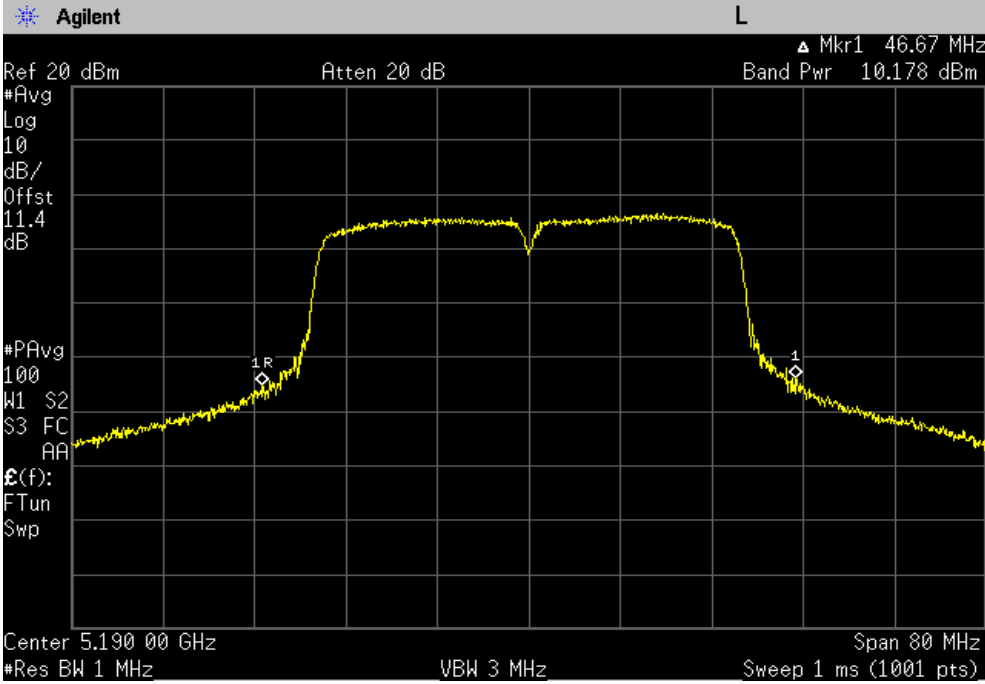

#### Maximum Peak Output Power, Highest Channel (5230 MHz)

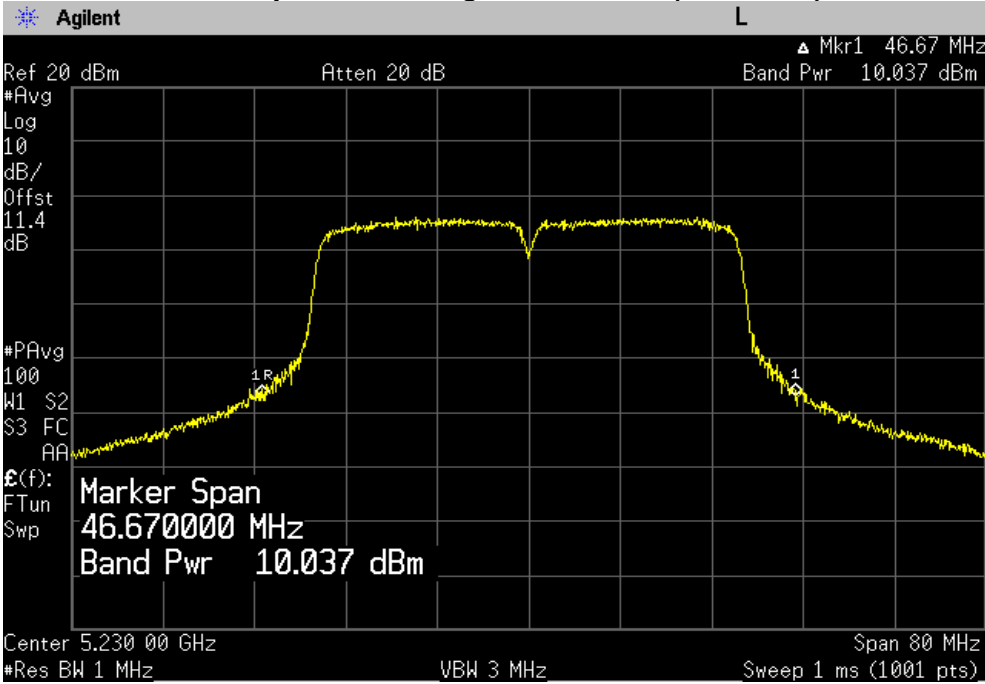



# PLOT OF TEST DATA

## Chain 1

### Maximum Peak Output Power, Lowest Channel (5190 MHz)

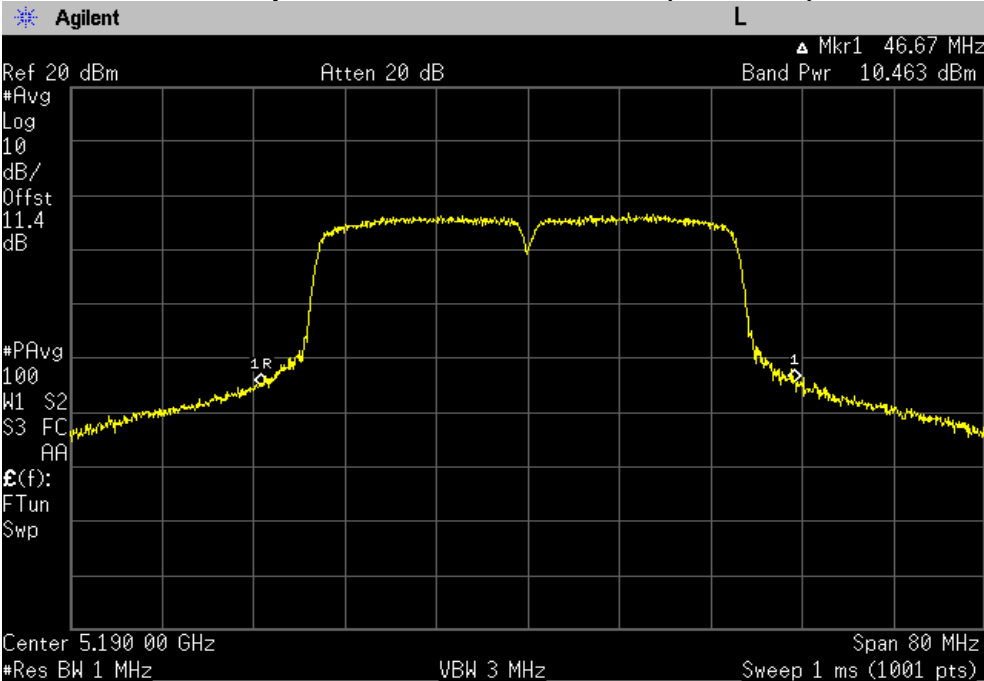

### Maximum Peak Output Power, Highest Channel (5230 MHz)

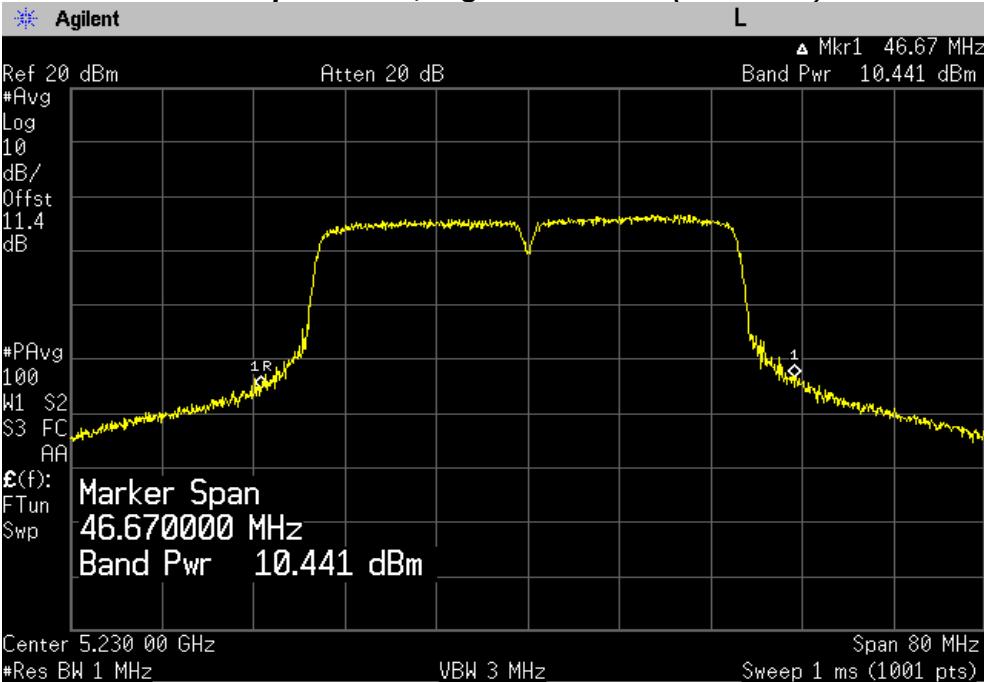

# TEST DATA

## 8.4.2 Maximum Peak Output Power – Band II

**FCC §15.407(a), RSS-210 Issue 8, A9.2**

**Test Mode : Set to Lowest channel, Middle channel and Highest channel**

### **802.11a**

Channel	Frequency(MHz)	Peak Output Power (dBm)		Limit (dBm)
		Chain 0	Chain 1	
Low	5260	14.46	15.12	24.0
Middle	5280	13.95	14.74	24.0
High	5320	13.91	13.92	24.0

### **802.11n(20 MHz)**

Channel	Frequency (MHz)	Peak Output Power (dBm)		*Total Peak Power (dBm)	Limit (dBm)
		Chain 0	Chain 1		
Low	5260	12.05	12.36	15.22	24.0
Middle	5280	11.80	11.92	14.87	24.0
High	5320	11.09	11.35	14.23	24.0

### **802.11n(40 MHz)**

Channel	Frequency (MHz)	Peak Output Power (dBm)		*Total Peak Power (dBm)	Limit (dBm)
		Chain 0	Chain 1		
Low	5270	11.41	11.45	14.44	24.0
High	5310	10.69	10.75	13.73	24.0

**Note:**

The following equation was used for spectrum offset:

$$\text{Spectrum offset (dB)} = \text{Attenuator (dB)} + \text{Cable Loss (dB)} + \text{SMA Type Connector Loss (dB)}$$

For the band 5.25~5.35 GHz, the maximum conducted output power over the frequency band of operation shall not exceed the lesser of **250 mW(24 dBm)** or  $11 \text{ dBm} + 10\log(26 \text{ dB Bandwidth})$

$$= 11 \text{ dBm} + 10\log(24.37) = 24.87 \text{ dBm}$$

**The maximum conducted output limit is 24 dBm.**

$$*\text{Total Peak power} = 10 \log [(10^{(\text{Chain 0 Power}/10)} + 10^{(\text{Chain 1 Power}/10)})]$$

# PLOT OF TEST DATA

**802.11a mode**

**Chain 0**

**Maximum Peak Output Power, Lowest Channel (5260 MHz)**

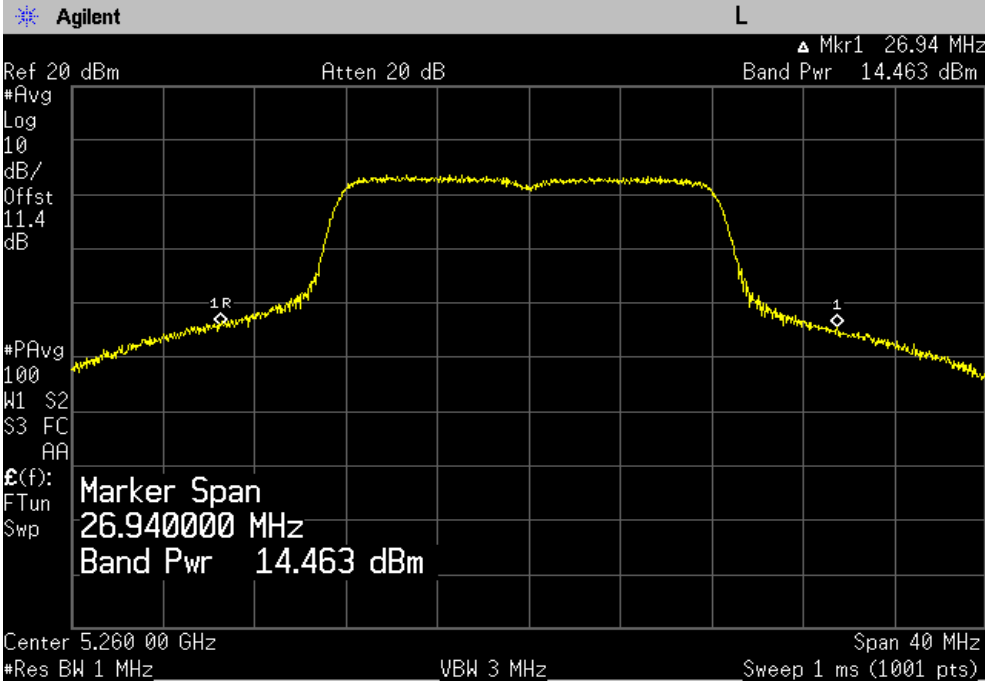

**Maximum Peak Output Power, Middle Channel (5280 MHz)**

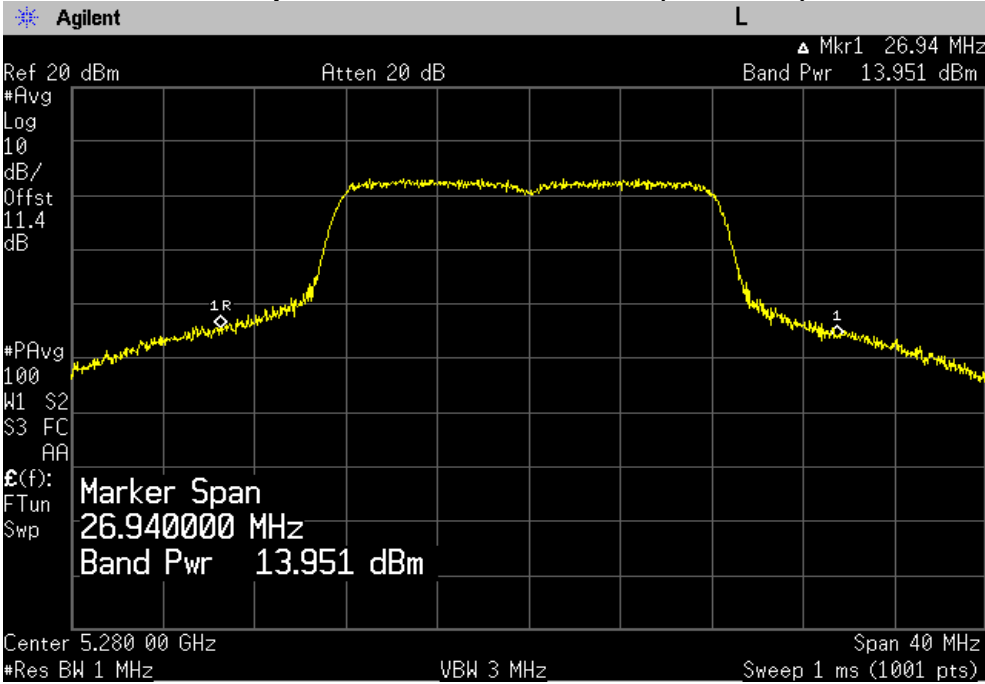

# PLOT OF TEST DATA

## Maximum Peak Output Power, Highest Channel (5320 MHz)

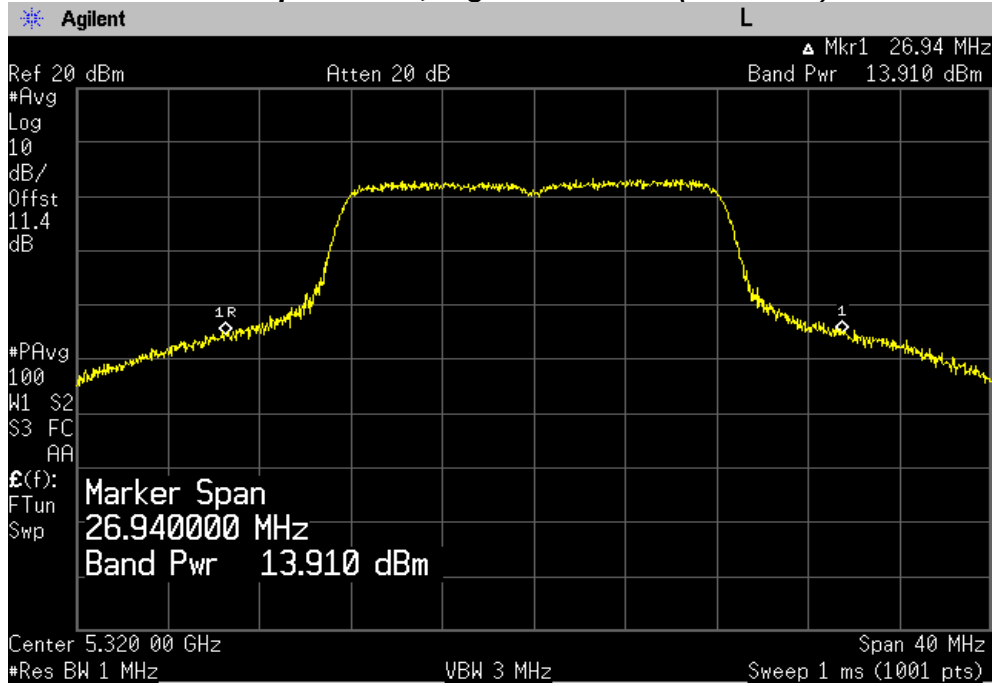

## Chain 1

## Maximum Peak Output Power, Lowest Channel (5260 MHz)

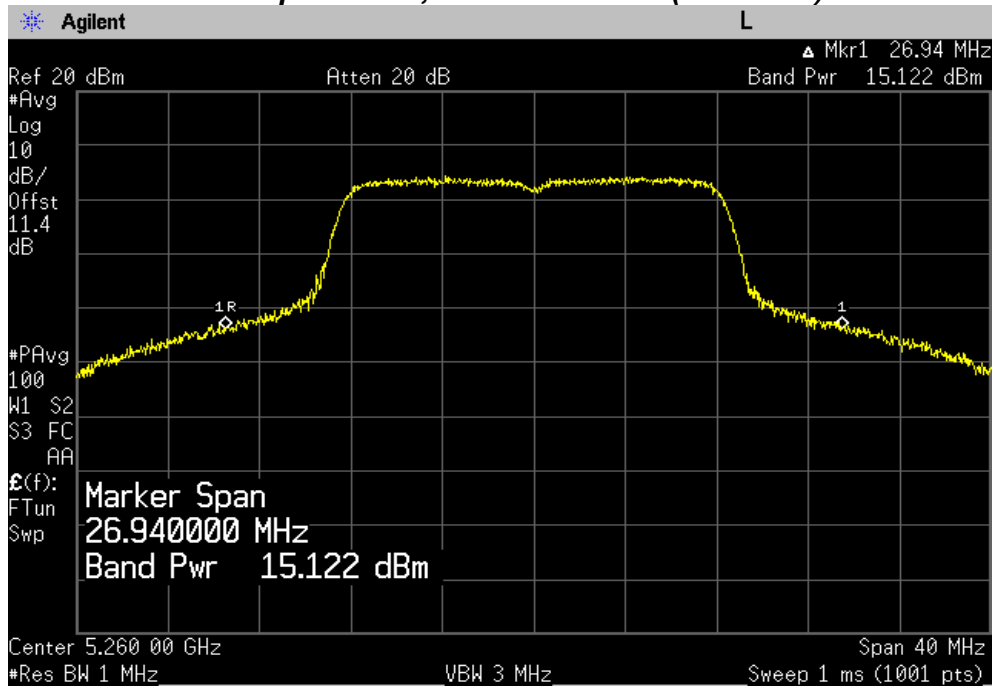

# PLOT OF TEST DATA

**Maximum Peak Output Power, Middle Channel (5280 MHz)**

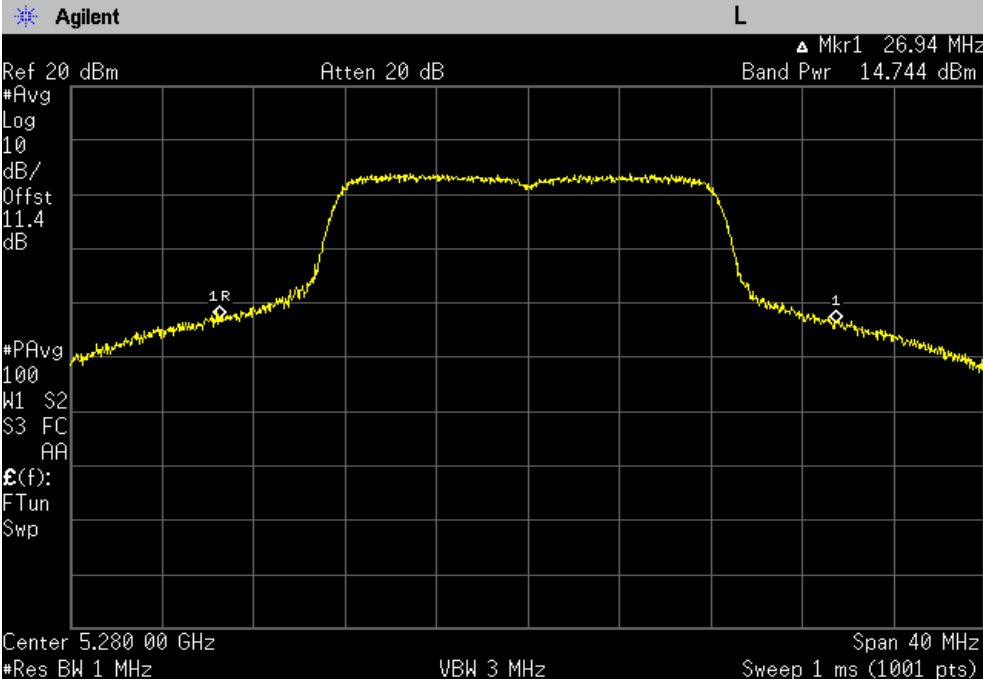

**Maximum Peak Output Power, Highest Channel (5320 MHz)**

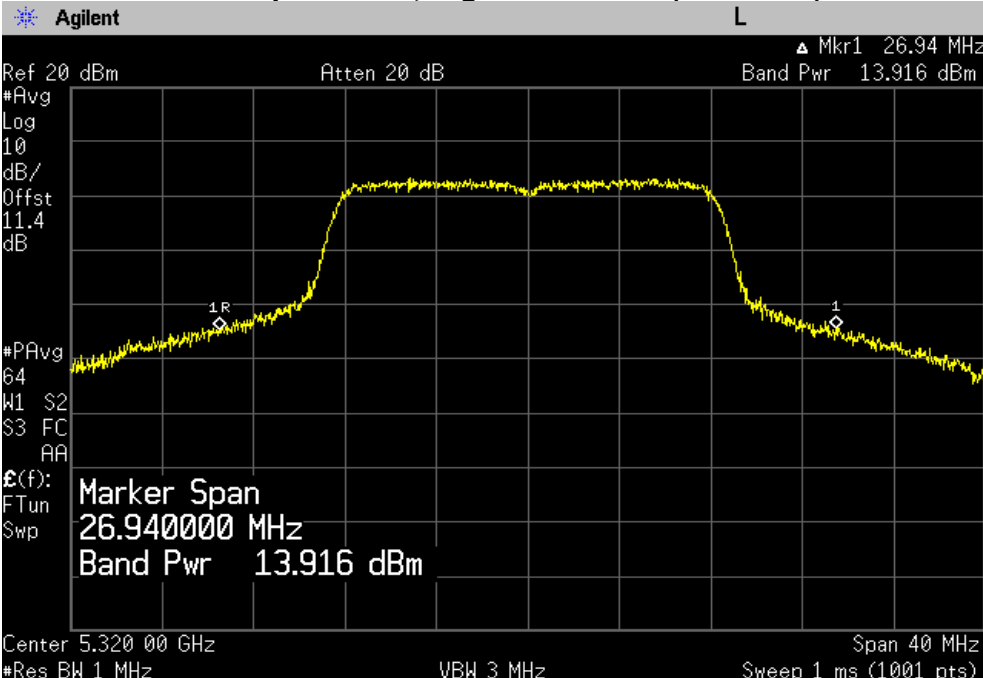

# PLOT OF TEST DATA

## 802.11a mode

### Chain 0

#### Maximum Peak Output Power, Lowest Channel (5260 MHz)

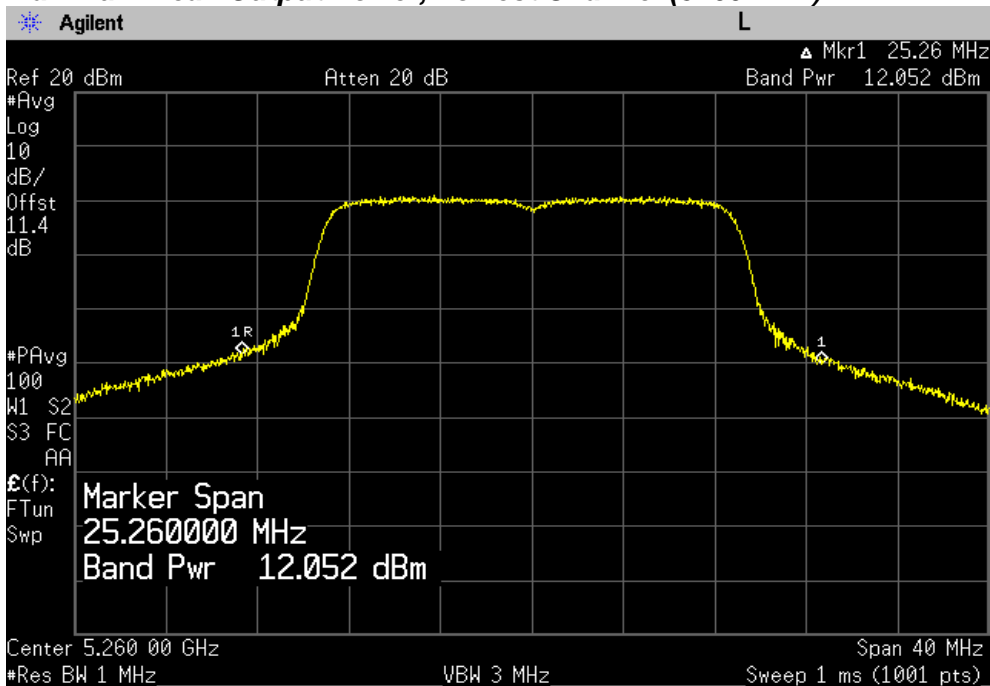

#### Maximum Peak Output Power, Middle Channel (5280 MHz)

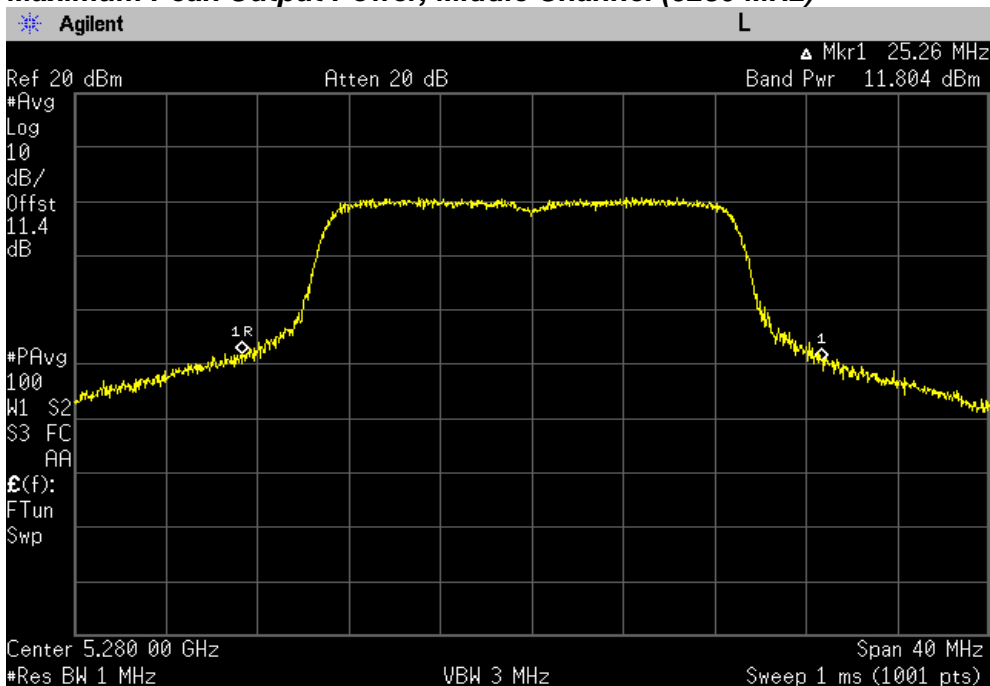

# PLOT OF TEST DATA

## Maximum Peak Output Power, Highest Channel (5320 MHz)

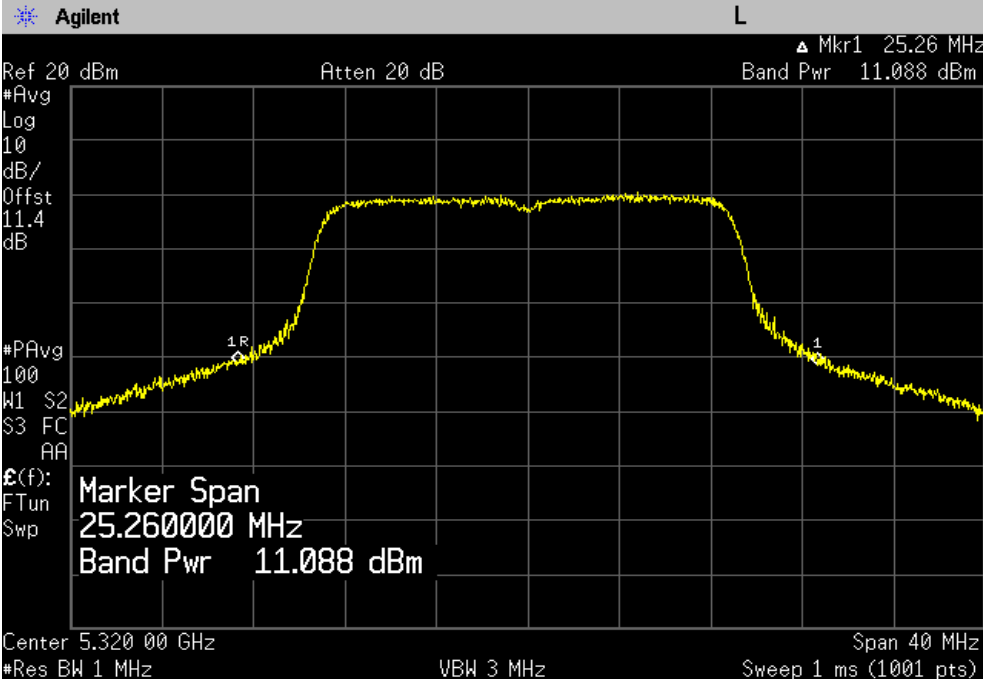

## Chain 1

## Maximum Peak Output Power, Lowest Channel (5260 MHz)

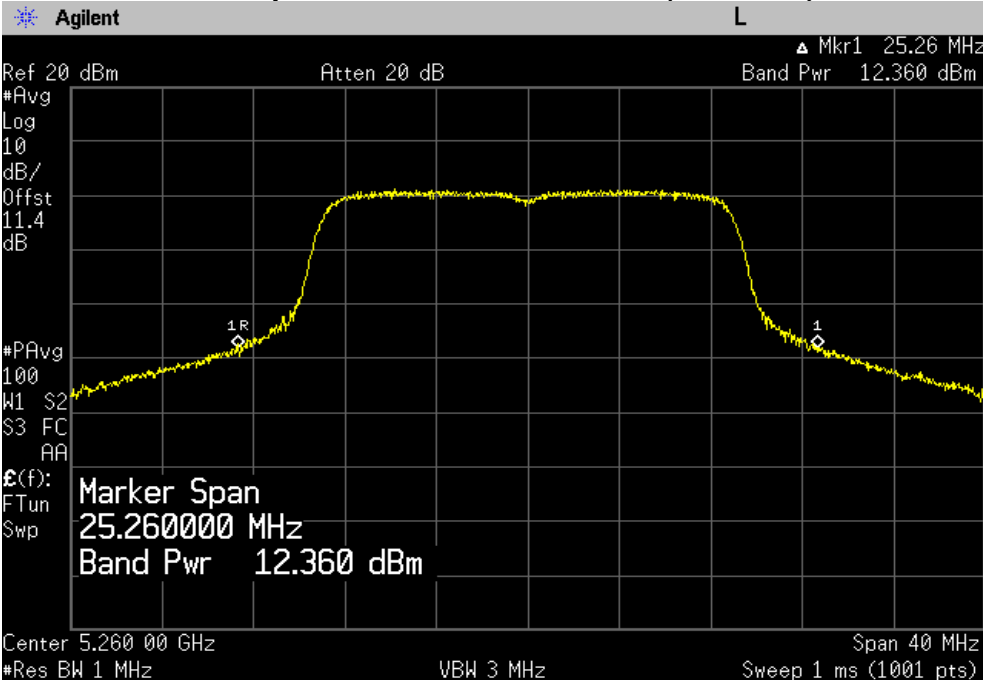



# PLOT OF TEST DATA

**Maximum Peak Output Power, Middle Channel (5280 MHz)**

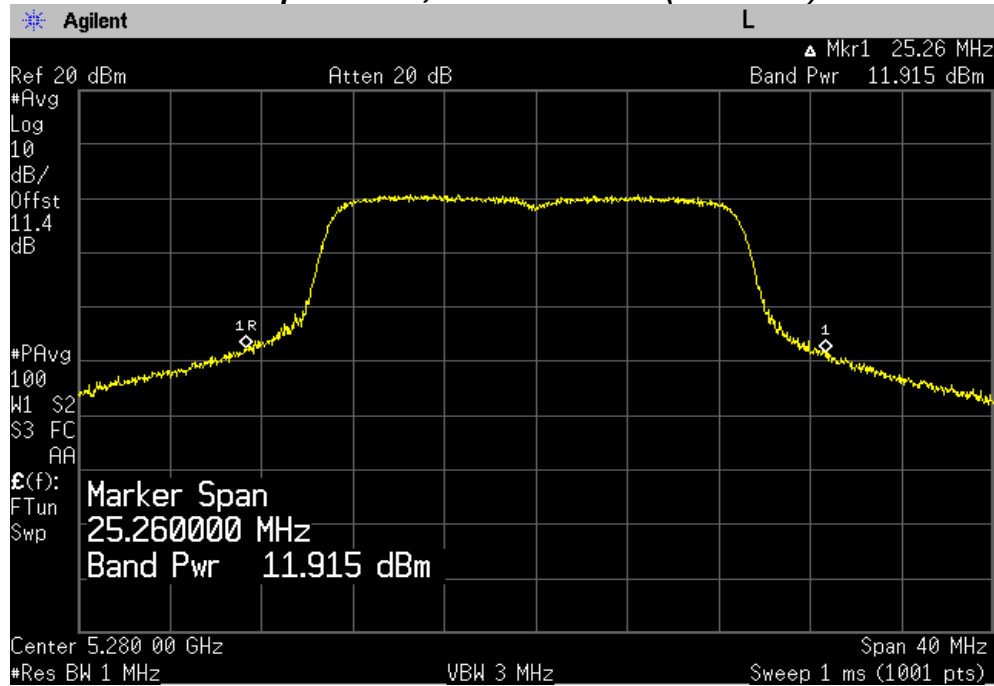

**Maximum Peak Output Power, Highest Channel (5320 MHz)**

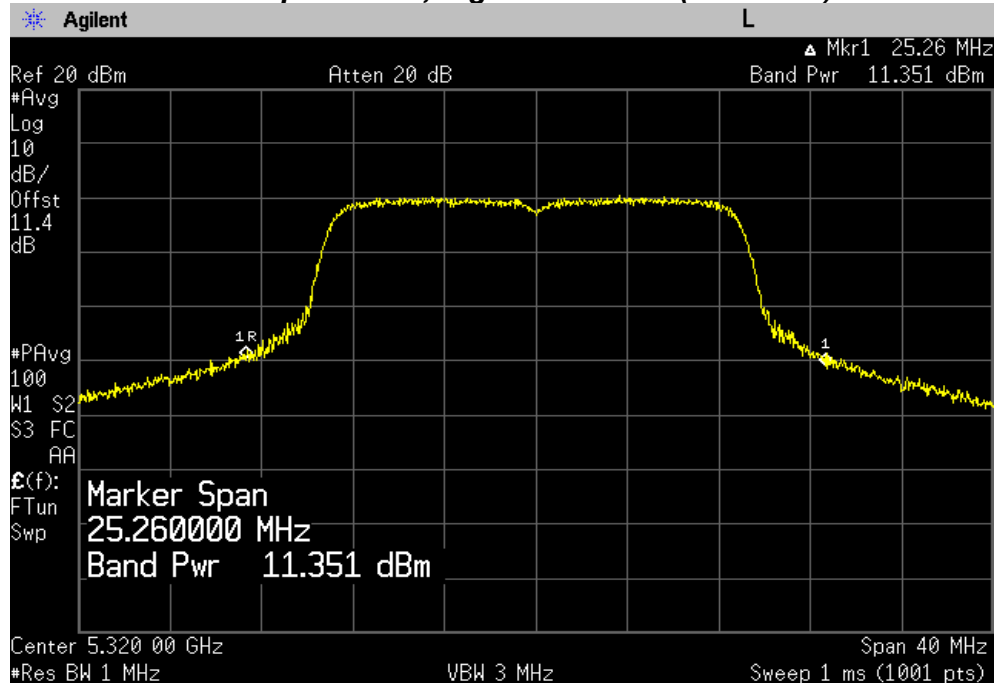

# PLOT OF TEST DATA

## 802.11n(40 MHz) mode

### Chain 0

#### Maximum Peak Output Power, Lowest Channel (5270 MHz)

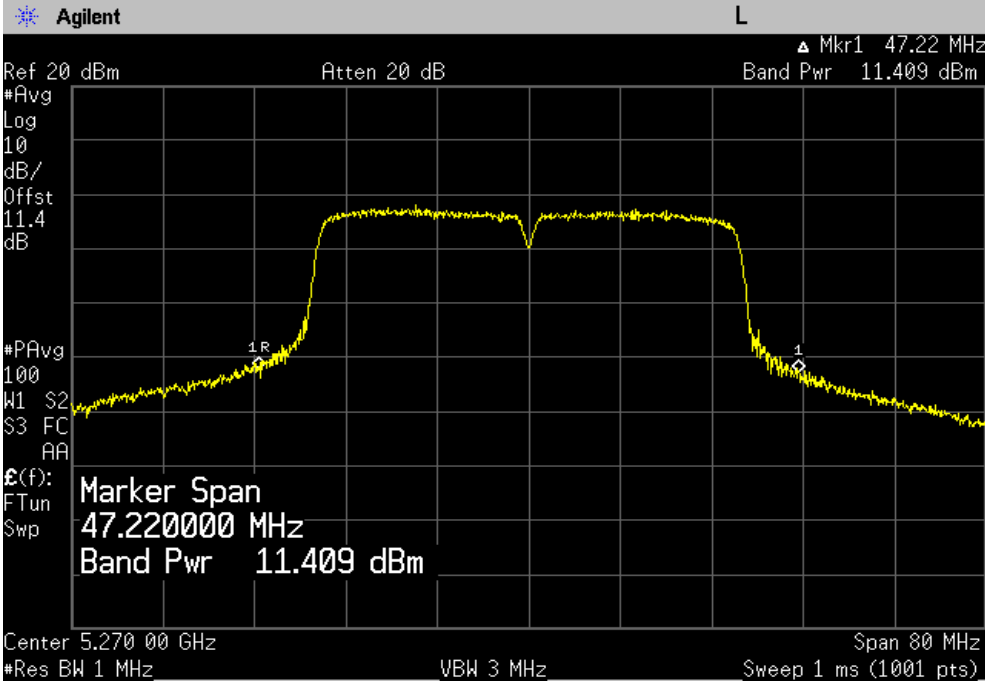

#### Maximum Peak Output Power, Highest Channel (5310 MHz)

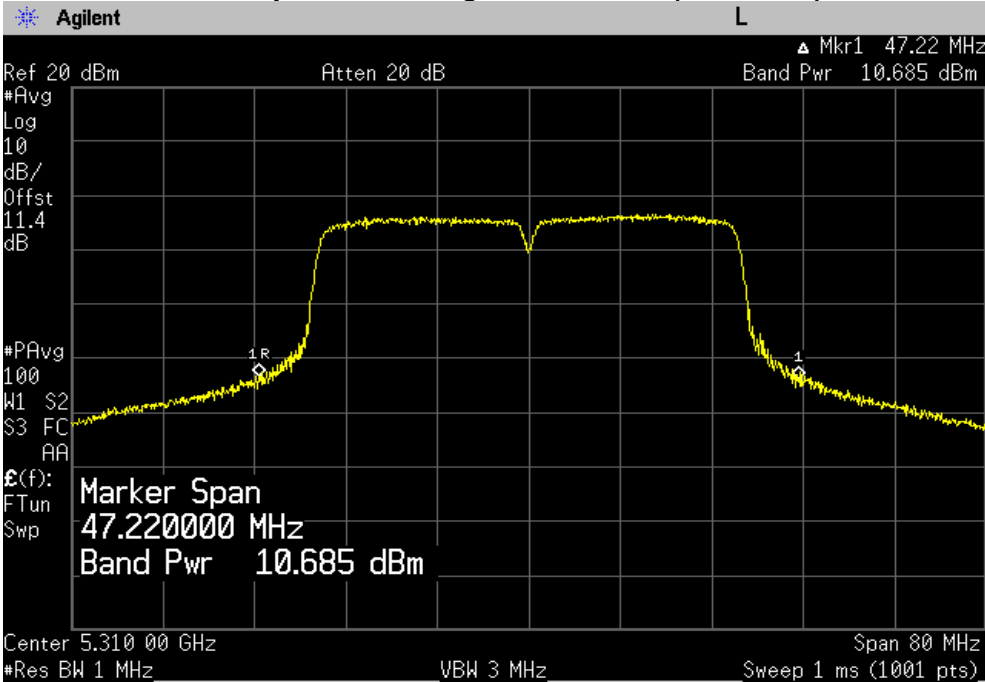

# PLOT OF TEST DATA

**Chain 1**

**Maximum Peak Output Power, Lowest Channel (5270 MHz)**

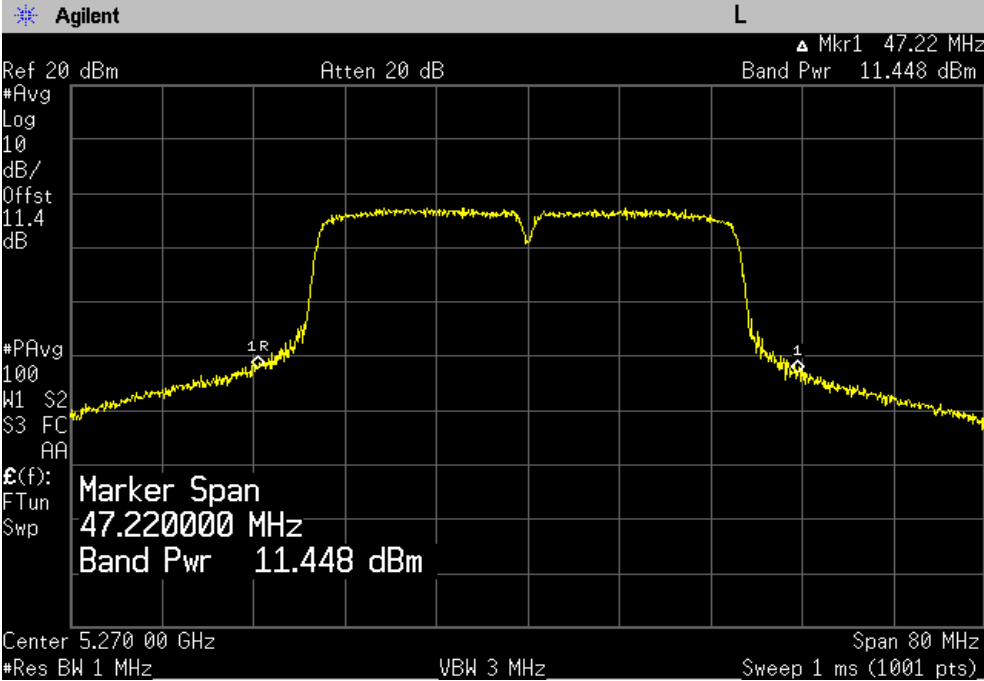

**Maximum Peak Output Power, Highest Channel (5310 MHz)**

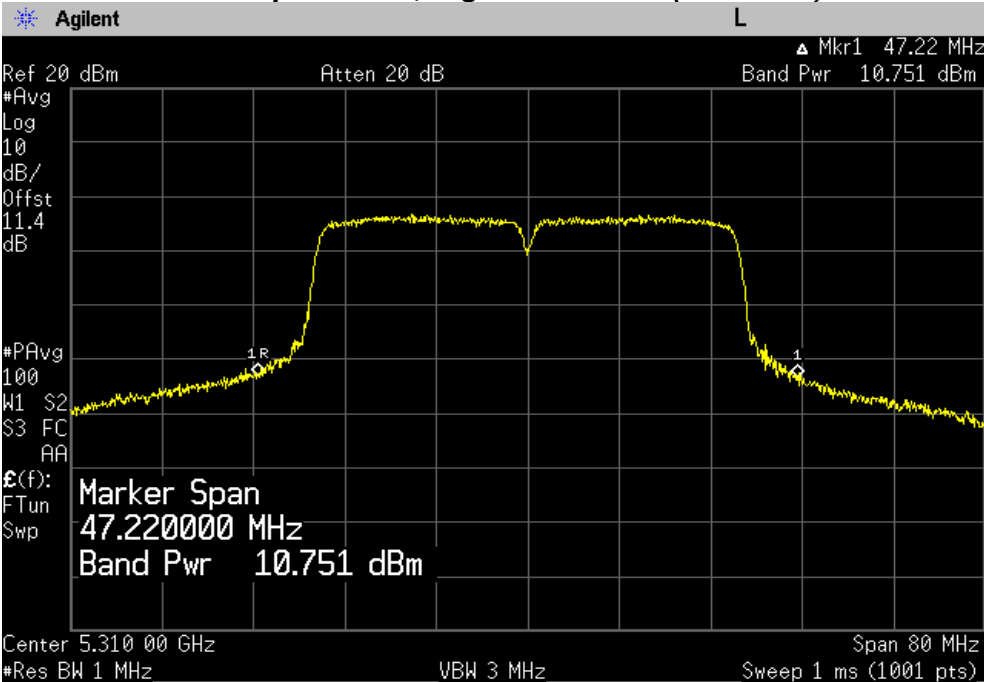

# TEST DATA

## 8.4.3 Maximum Peak Output Power – Band III

FCC §15.407(a), RSS-210 Issue 8, A9.2

Test Mode : Set to Lowest channel, Middle channel and Highest channel

### 802.11a

Channel	Frequency(MHz)	Peak Output Power (dBm)		Limit (dBm)
		Chain 0	Chain 1	
Low	5500	13.77	14.35	24.0
Middle	5580	15.12	15.25	24.0
High	5700	15.40	15.08	24.0

### 802.11n(20 MHz)

Channel	Frequency (MHz)	Peak Output Power (dBm)		*Total Peak Power (dBm)	Limit (dBm)
		Chain 0	Chain 1		
Low	5500	12.26	12.34	15.31	24.0
Middle	5580	13.54	12.62	16.11	24.0
High	5700	13.82	12.37	16.17	24.0

### 802.11n(40 MHz)

Channel	Frequency (MHz)	Peak Output Power (dBm)		*Total Peak Power (dBm)	Limit (dBm)
		Chain 0	Chain 1		
Low	5510	8.71	8.25	11.50	24.0
Middle	5590	9.82	9.26	12.56	24.0
High	5670	9.87	9.03	12.48	24.0

**Note:**

The following equation was used for spectrum offset:

$$\text{Spectrum offset (dB)} = \text{Attenuator (dB)} + \text{Cable Loss (dB)} + \text{SMA Type Connector Loss (dB)}$$

For the band 5.47~5.725 GHz, the maximum conducted output power over the frequency band of operation shall not exceed the lesser of **250 mW(24 dBm)** or  $11 \text{ dBm} + 10\log(26 \text{ dB Bandwidth})$   
 $= 11 \text{ dBm} + 10\log(25.23) = 25.02 \text{ dBm}$

**The maximum conducted output limit is 24 dBm.**

$$\text{*Total Peak power} = 10 \log [(10^{(\text{Chain 0 Power}/10)} + 10^{(\text{Chain 1 Power}/10)} )]$$

# PLOT OF TEST DATA

## 802.11a mode

### Chain 0

#### Maximum Peak Output Power, Lowest Channel (5500 MHz)

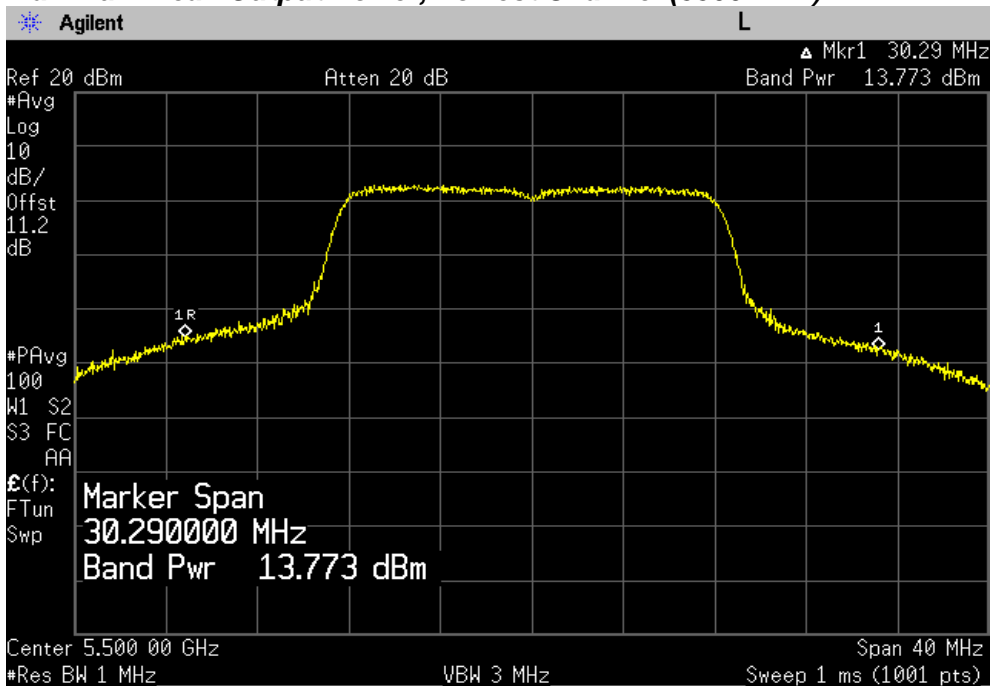

#### Maximum Peak Output Power, Middle Channel (5580 MHz)

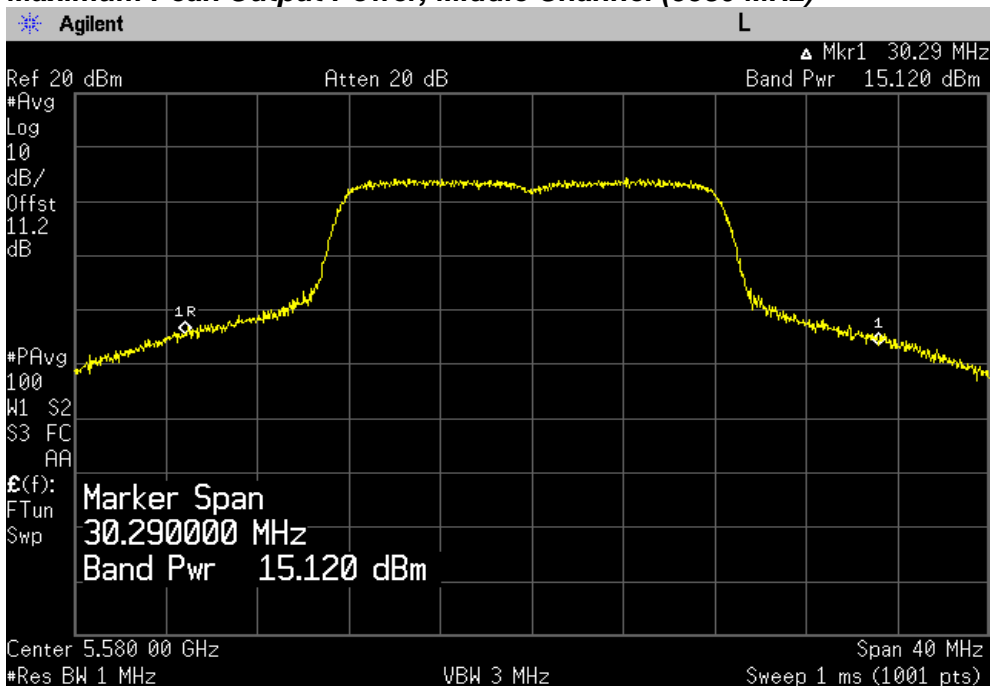

# PLOT OF TEST DATA

## Maximum Peak Output Power, Highest Channel (5700 MHz)

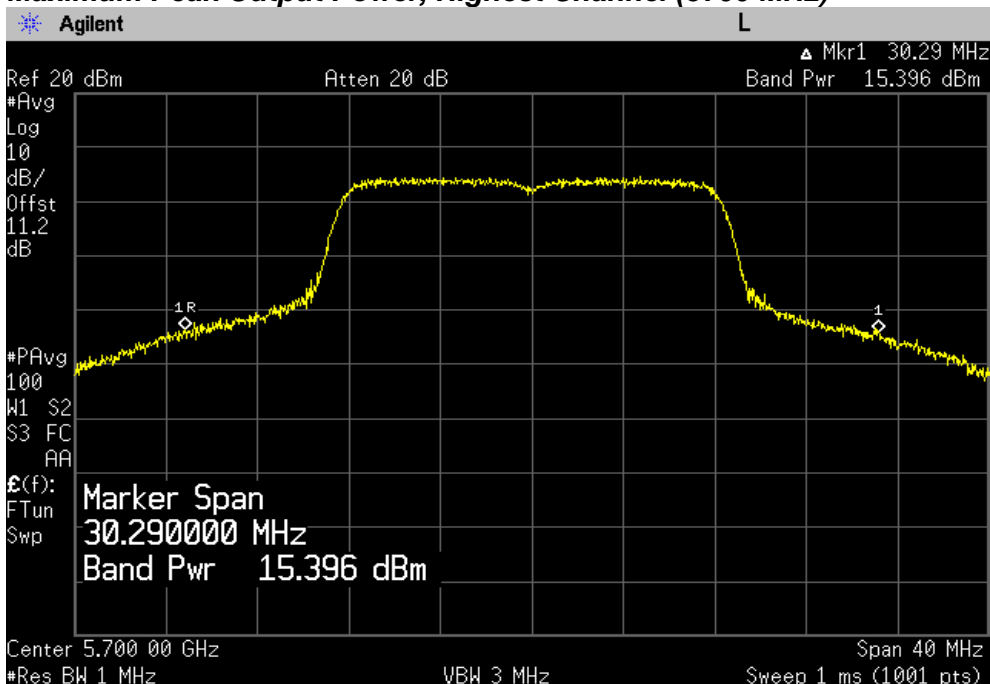

## Chain 1

## Maximum Peak Output Power, Lowest Channel (5500 MHz)

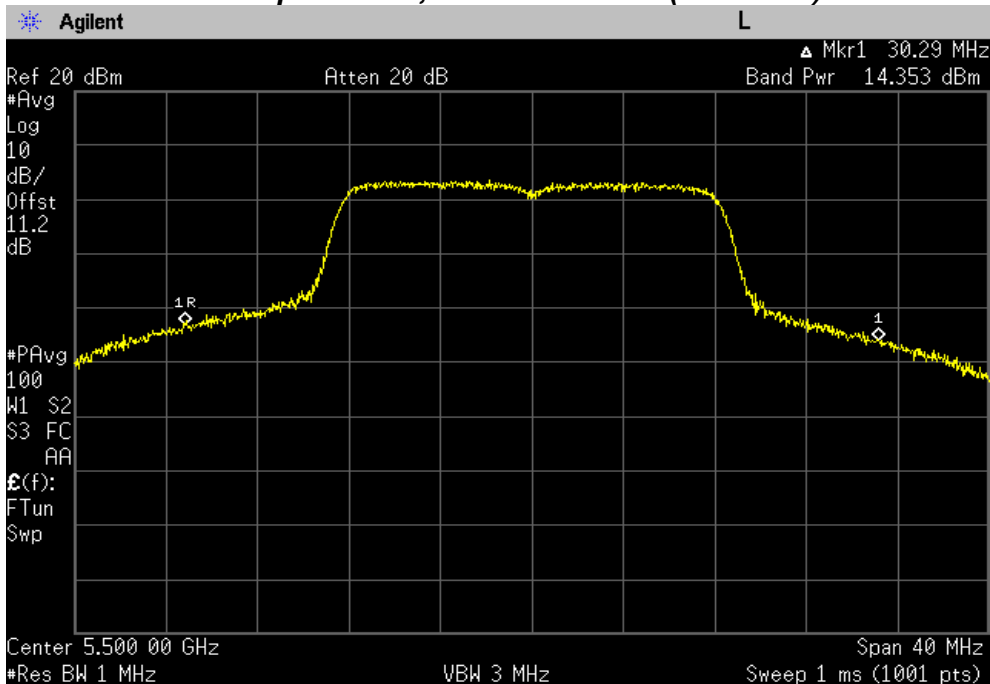

# PLOT OF TEST DATA

**Maximum Peak Output Power, Middle Channel (5580 MHz)**

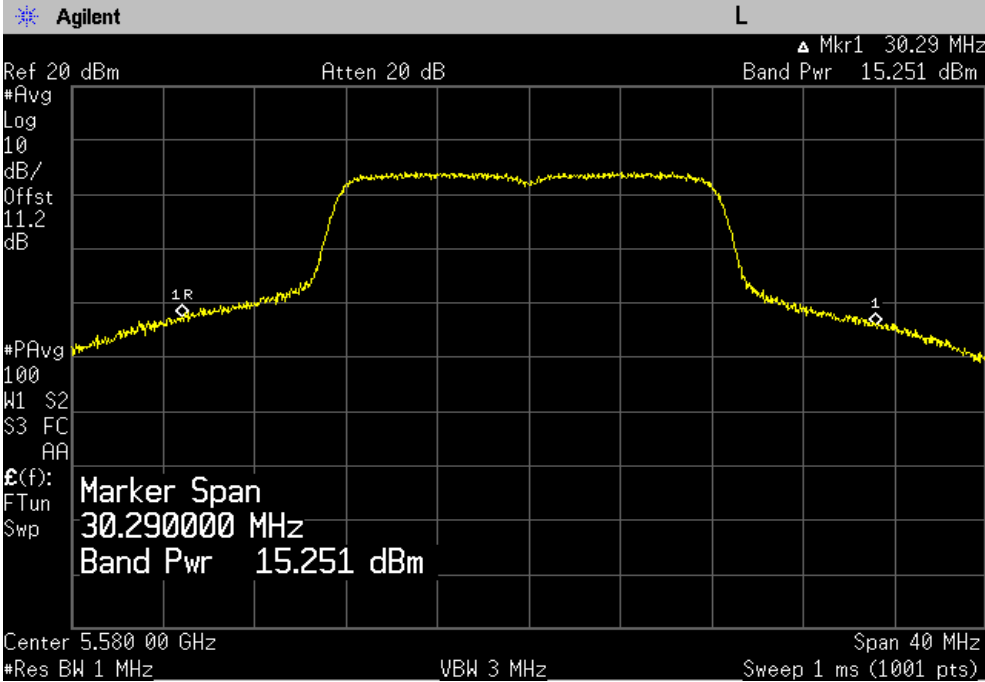

**Maximum Peak Output Power, Highest Channel (5700 MHz)**

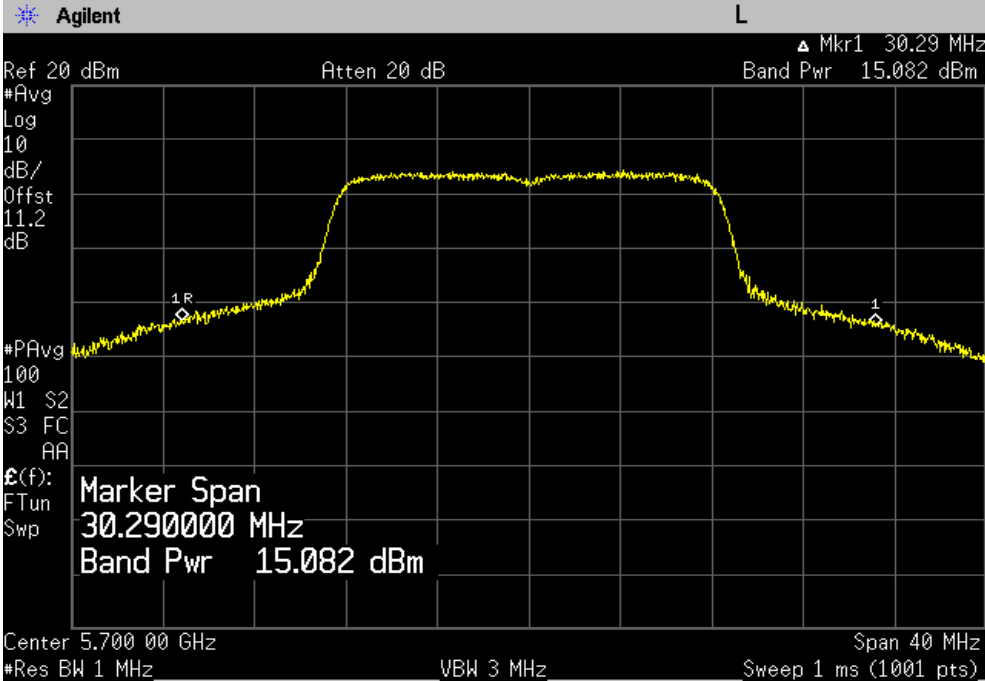



# PLOT OF TEST DATA

**802.11n(20 MHz) mode**

**Chain 0**

**Maximum Peak Output Power, Lowest Channel (5500 MHz)**

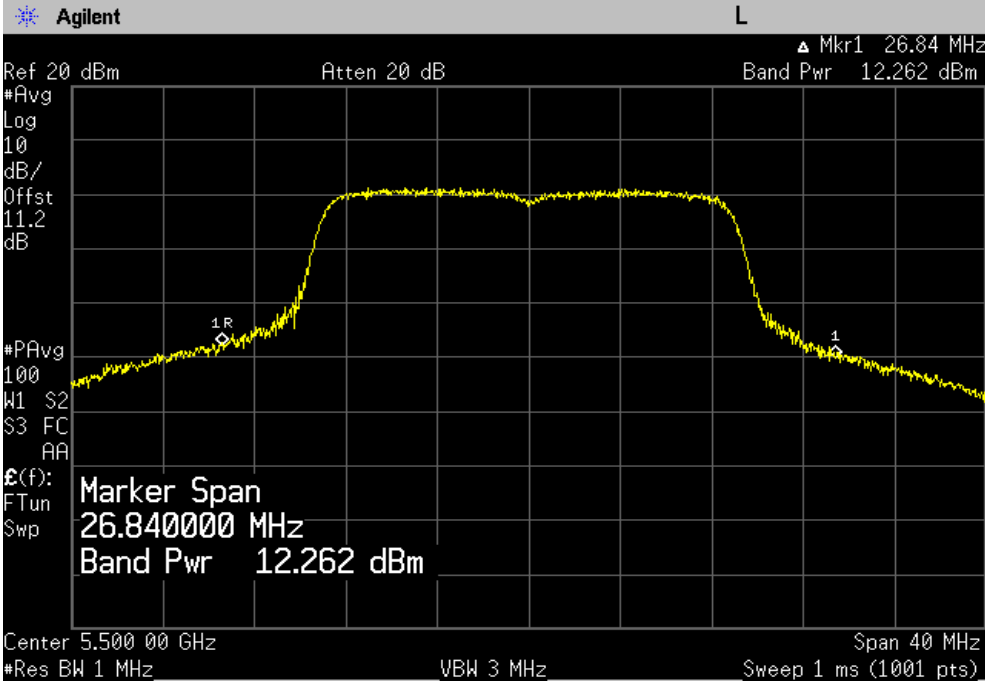

**Maximum Peak Output Power, Middle Channel (5580 MHz)**

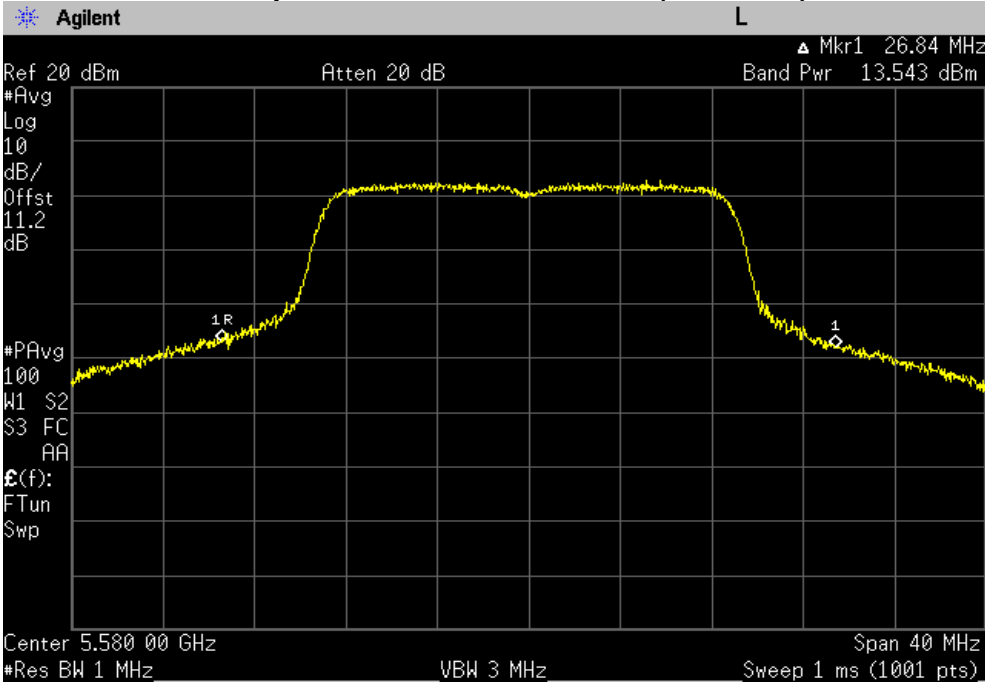

# PLOT OF TEST DATA

## Maximum Peak Output Power, Highest Channel (5700 MHz)

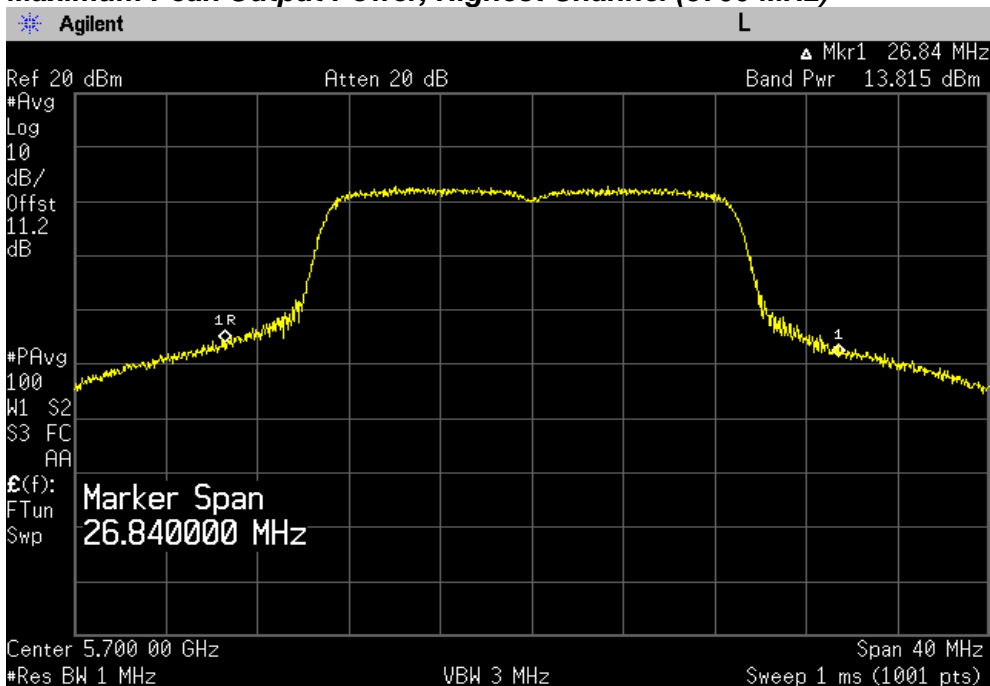

## Chain 1

## Maximum Peak Output Power, Lowest Channel (5500 MHz)

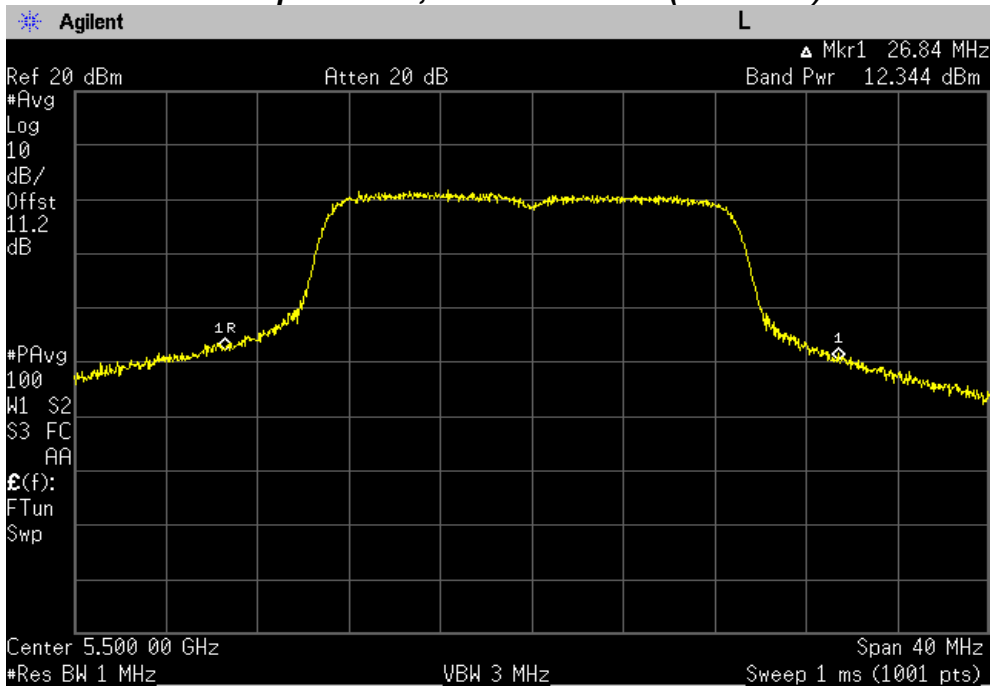

# PLOT OF TEST DATA

**Maximum Peak Output Power, Middle Channel (5580 MHz)**

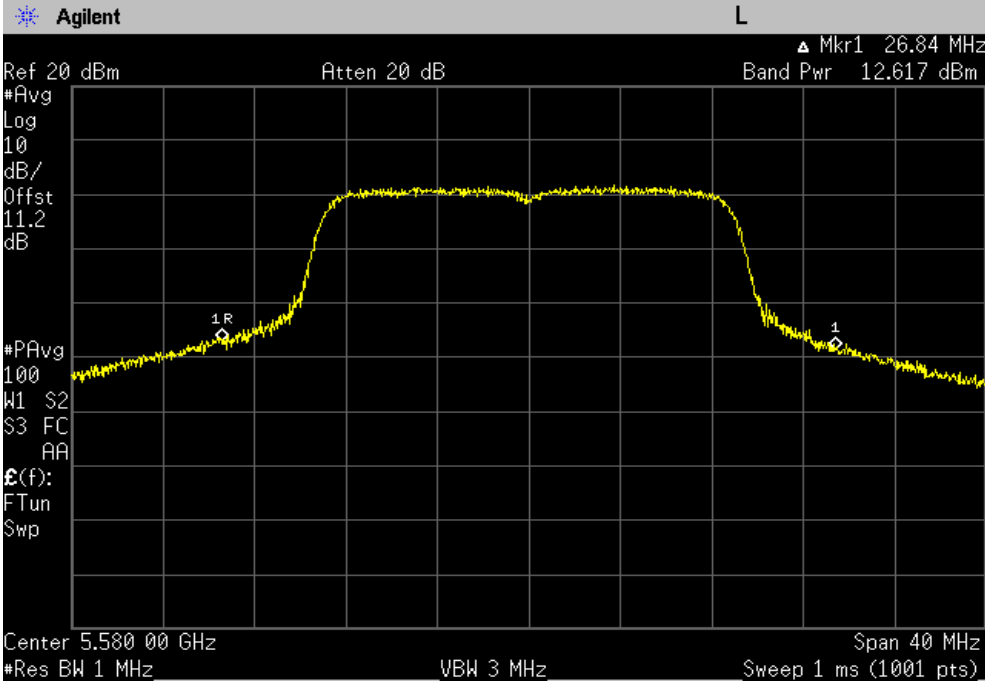

**Maximum Peak Output Power, Highest Channel (5700 MHz)**

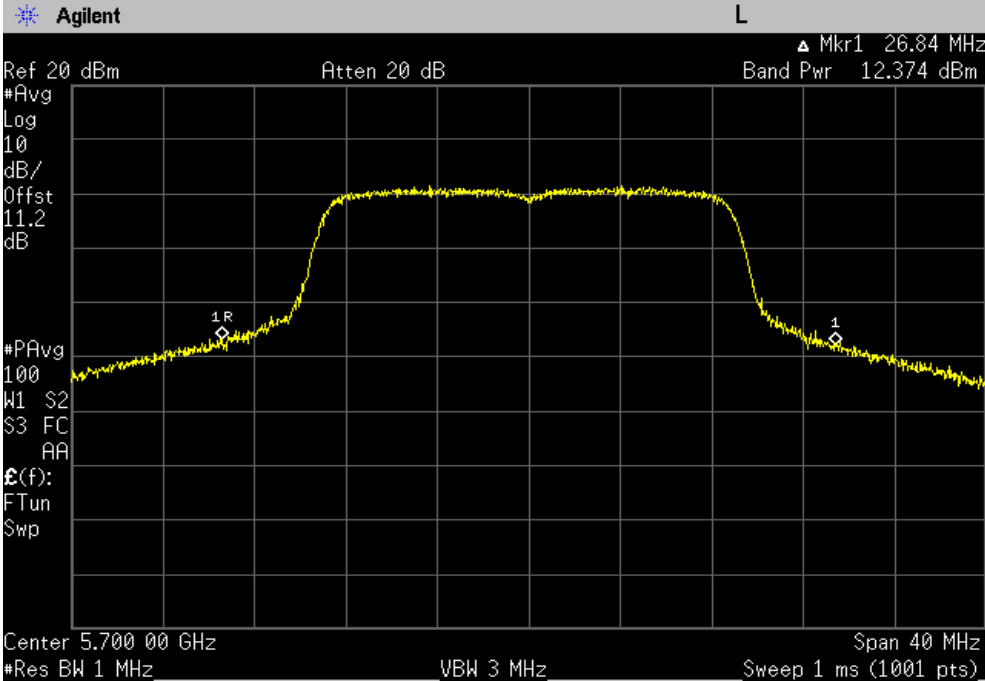

# PLOT OF TEST DATA

**802.11n(40 MHz) mode**

**Chain 0**

**Maximum Peak Output Power, Lowest Channel (5510 MHz)**

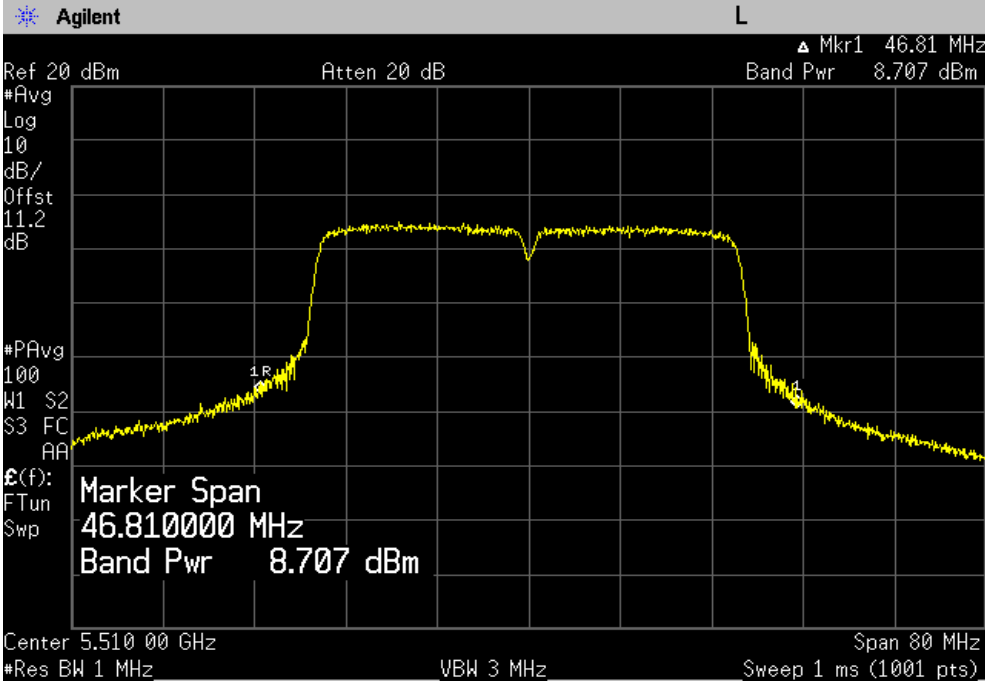

**Maximum Peak Output Power, Middle Channel (5590 MHz)**

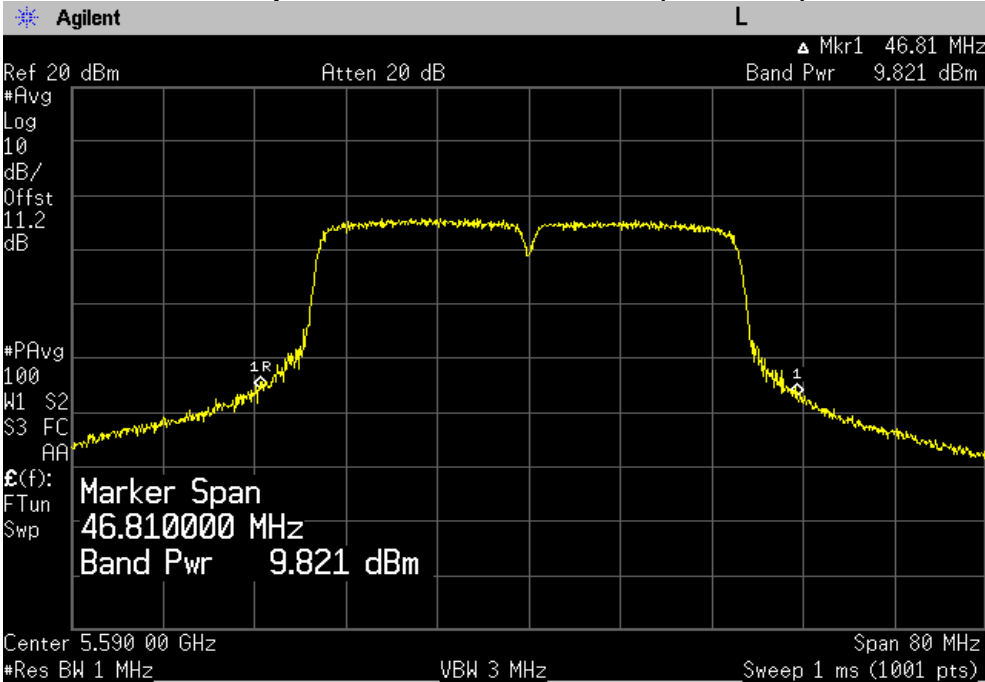

# PLOT OF TEST DATA

## Maximum Peak Output Power, Highest Channel (5670 MHz)

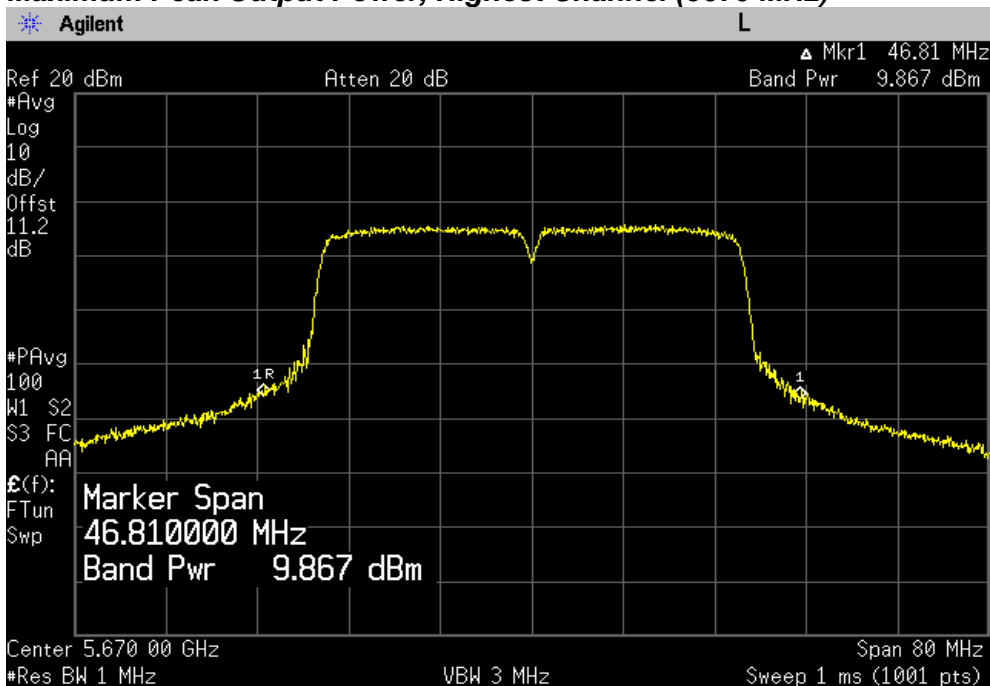

## Chain 1

## Maximum Peak Output Power, Lowest Channel (5510 MHz)

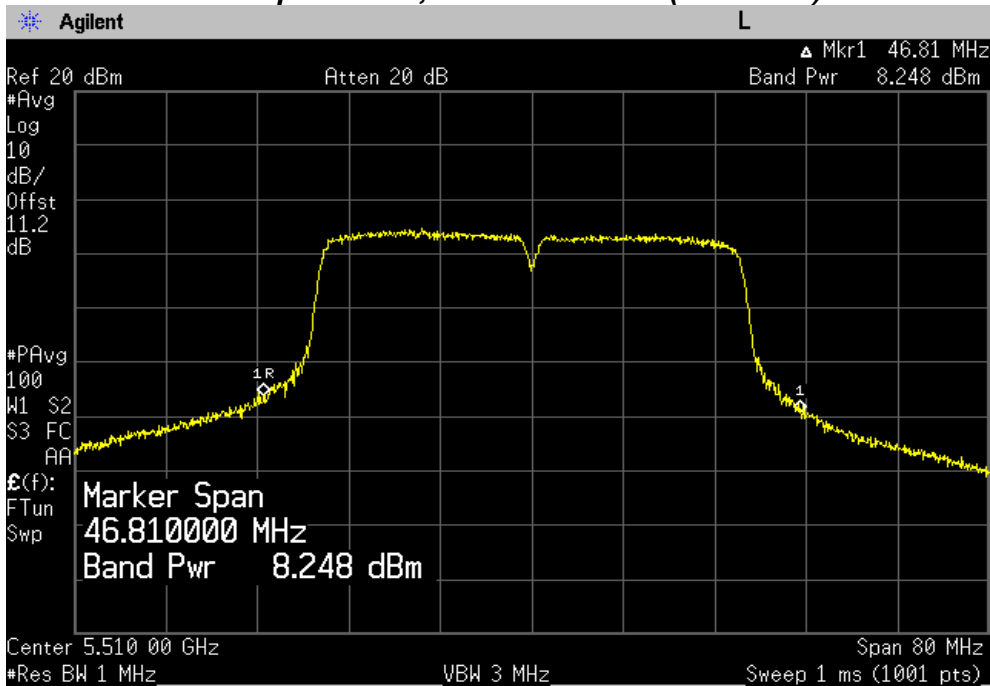

# PLOT OF TEST DATA

**Maximum Peak Output Power, Middle Channel (5590 MHz)**

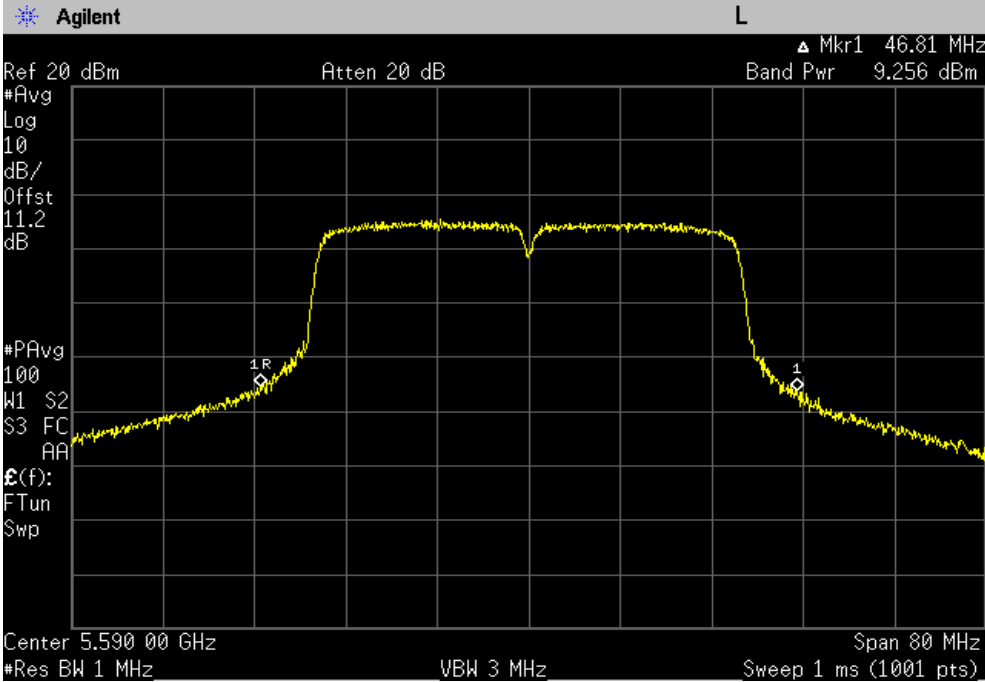

**Maximum Peak Output Power, Highest Channel (5670 MHz)**

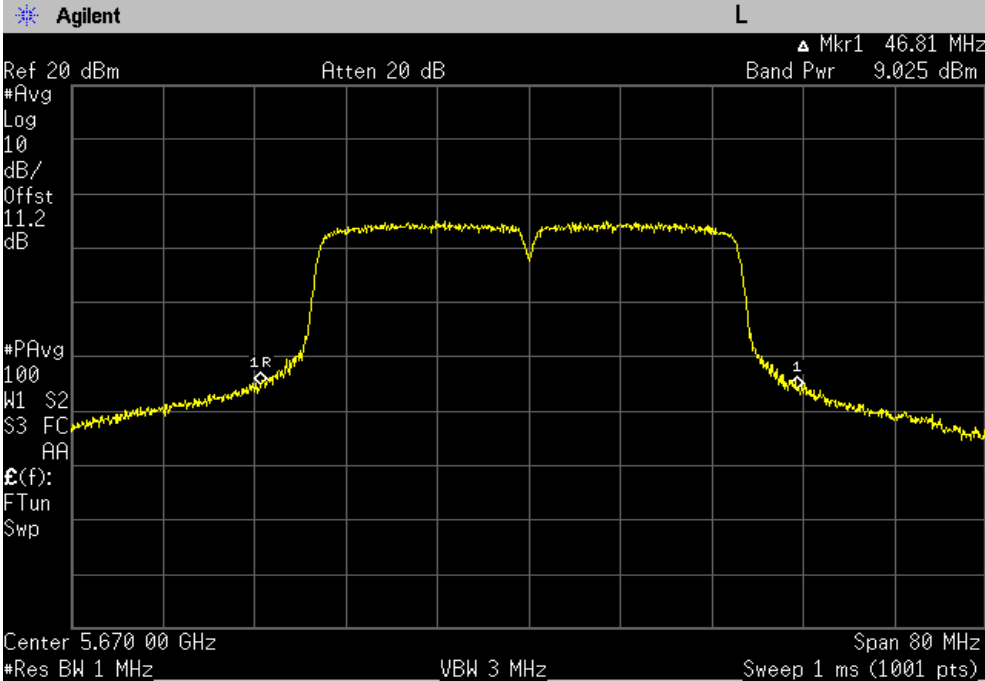

# TEST DATA

## 8.5 Power Spectral Density

### 8.5.1 Power Spectral Density – Band I

FCC §15.407(a), RSS-210 Issue 8, A9.2

Test Mode : Set to Lowest channel, Middle channel and Highest channel

#### 802.11a

Channel	Frequency(MHz)	Power Spectral Density (dBm)		Limit (dBm)
		Chain 0	Chain 1	
Low	5180	0.97	2.32	4.0
Middle	5200	1.24	1.82	4.0
High	5240	1.18	2.23	4.0

#### 802.11n(20 MHz)

Channel	Frequency (MHz)	Power Spectral Density (dBm)		*Total Power Spectral Density (dBm)	Limit (dBm)
		Chain 0	Chain 1		
Low	5180	-1.77	-0.63	1.85	8.0
Middle	5200	-0.56	-0.97	2.25	8.0
High	5240	-0.47	-0.84	2.36	8.0

#### 802.11n(40 MHz)

Channel	Frequency (MHz)	Power Spectral Density (dBm)		*Total Power Spectral Density (dBm)	Limit (dBm)
		Chain 0	Chain 1		
Low	5190	-1.88	-2.28	0.93	8.0
High	5230	-2.22	-2.08	0.86	8.0

**Note:**

The following equation was used for spectrum offset:

Spectrum offset (dB) = Attenuator (dB) + Cable Loss (dB) + SMA Type Connector Loss (dB)

\*Total Peak power =  $10 \log [10^{(\text{Chain 0 Power density}/10)} + 10^{(\text{Chain 1 Power density}/10)}]$

# PLOT OF TEST DATA

**802.11a mode**

**Chain 0**

**Peak Power Spectral Density, Lowest Channel (5218 MHz)**

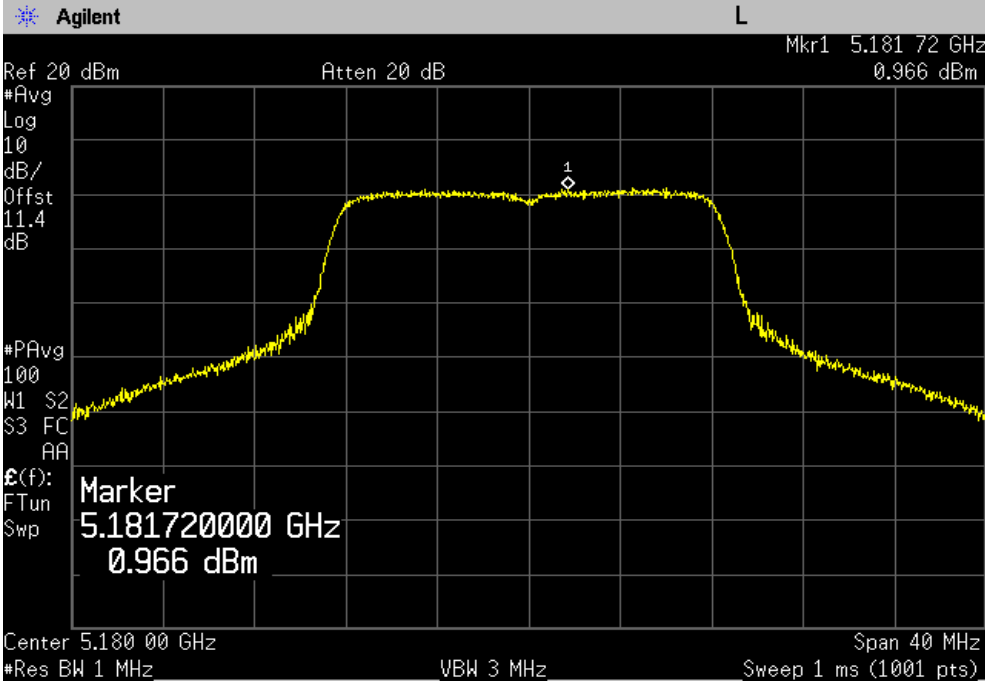

**Peak Power Spectral Density, Middle Channel (5200 MHz)**

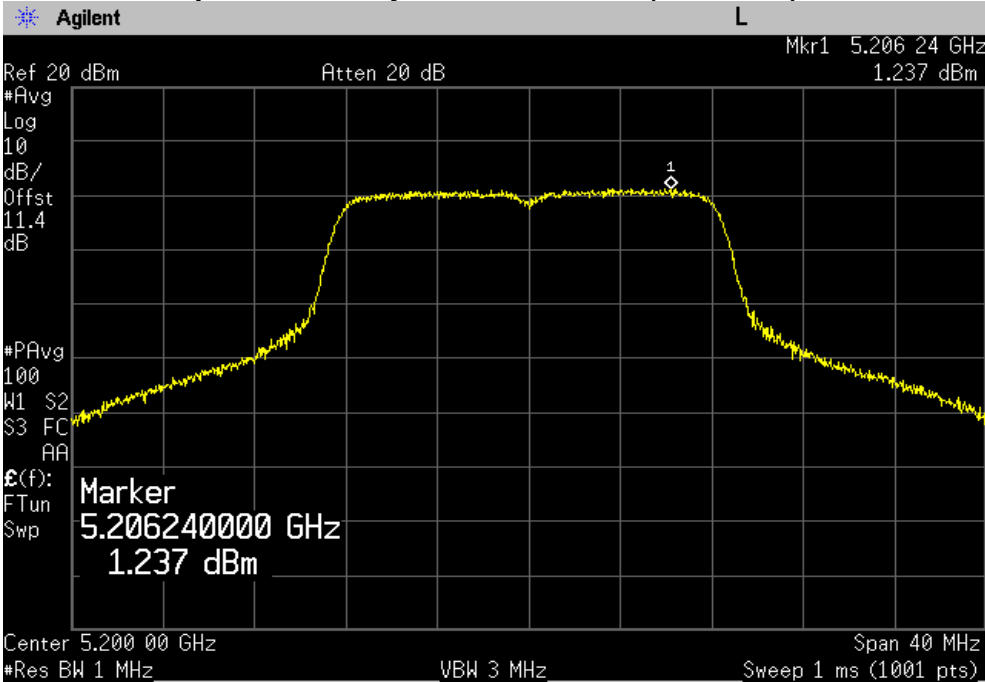



# PLOT OF TEST DATA

**Peak Power Spectral Density, Highest Channel (5240 MHz)**

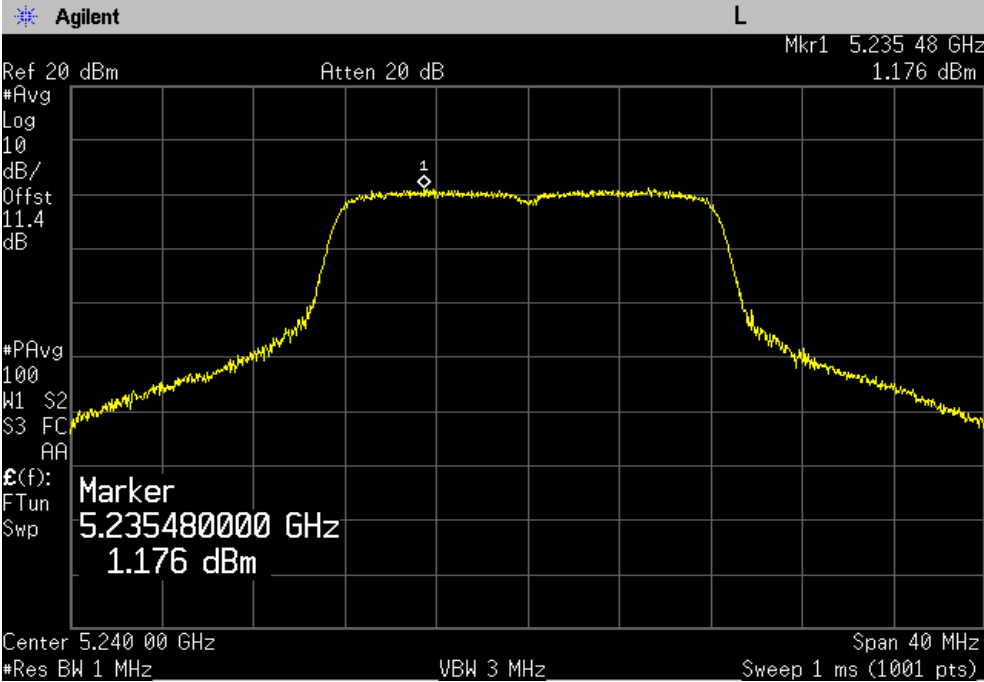

**Chain 1**

**Peak Power Spectral Density, Lowest Channel (5180 MHz)**

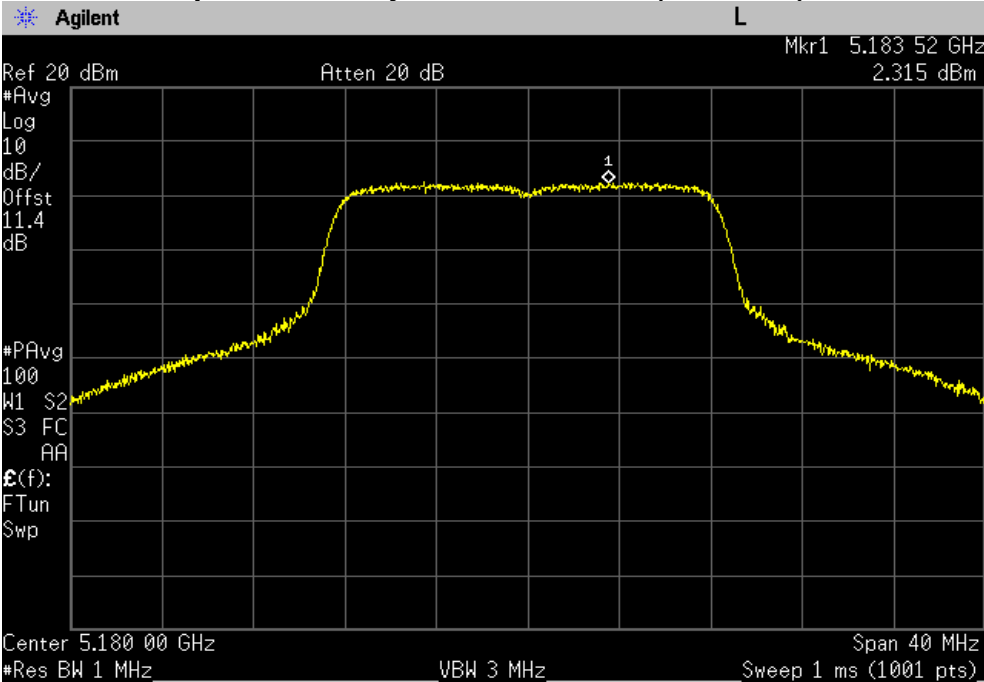

# PLOT OF TEST DATA

**Peak Power Spectral Density, Middle Channel (5200 MHz)**

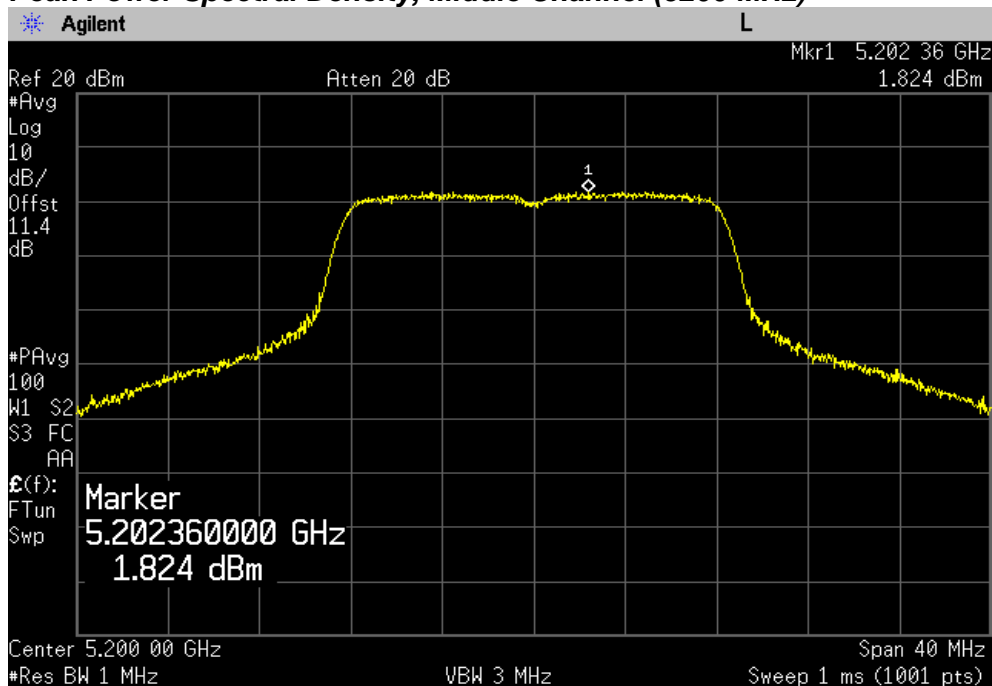

**Peak Power Spectral Density, Highest Channel (5240 MHz)**

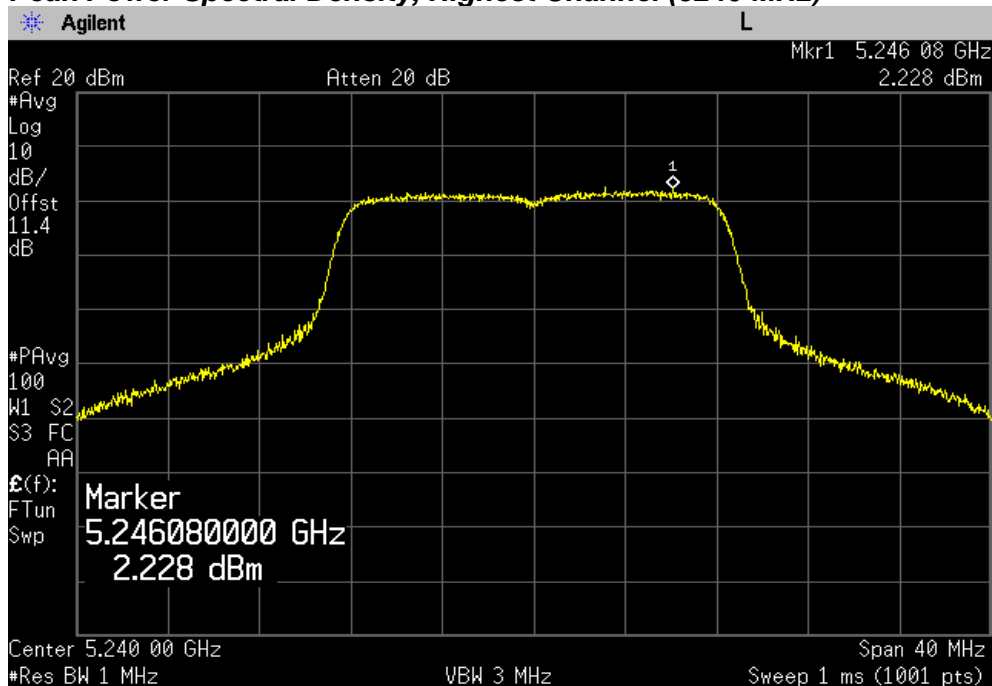

# PLOT OF TEST DATA

**802.11n(20 MHz) mode**

**Chain 0**

**Peak Power Spectral Density, Lowest Channel (5218 MHz)**

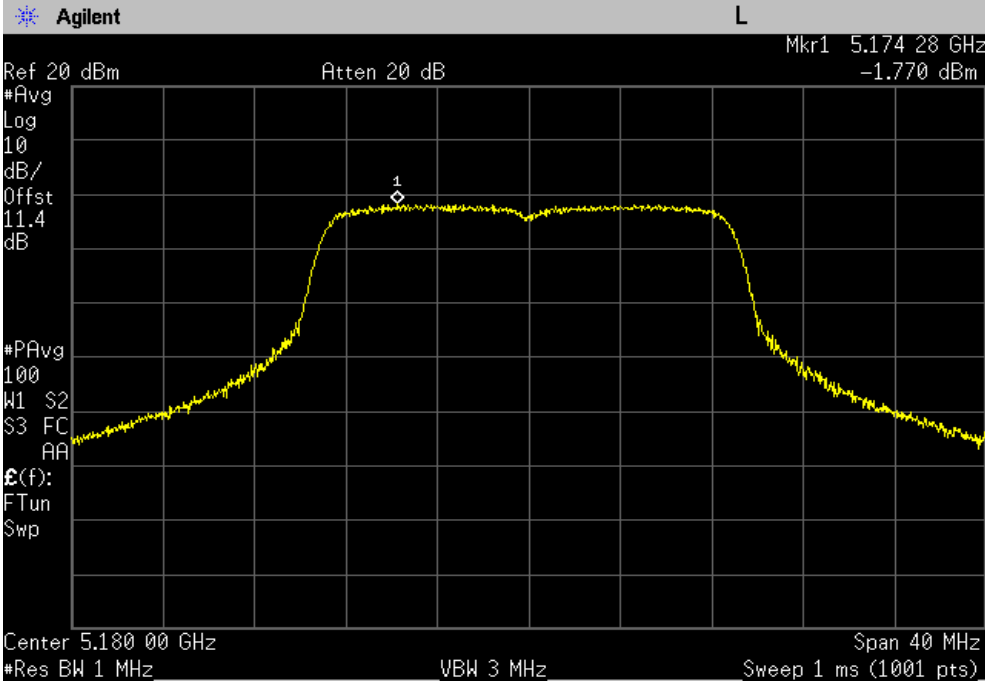

**Peak Power Spectral Density, Middle Channel (5200 MHz)**

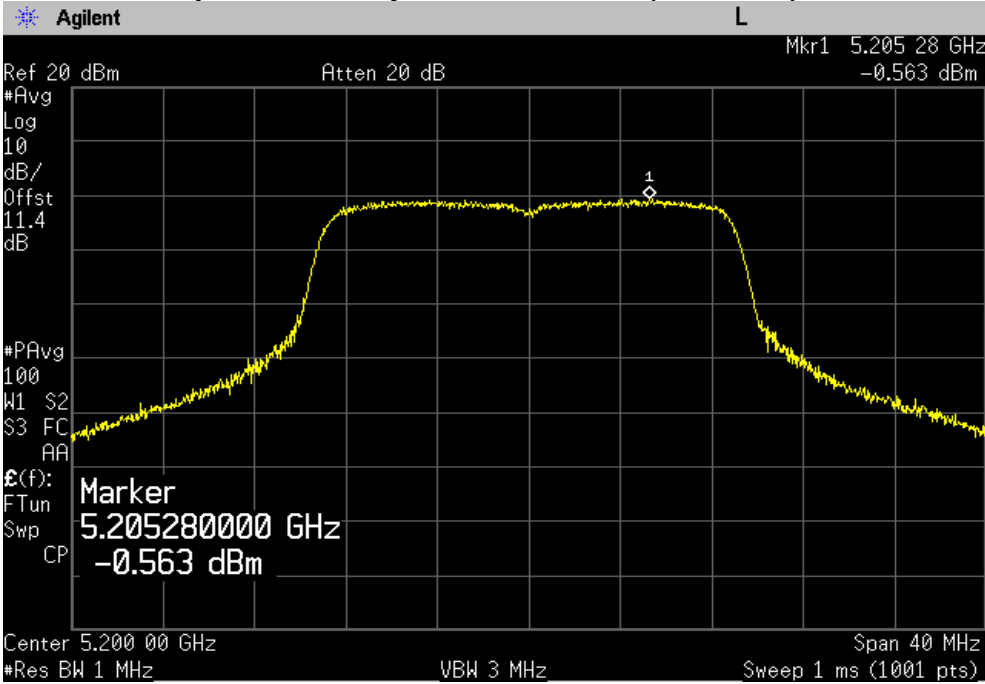

# PLOT OF TEST DATA

**Peak Power Spectral Density, Highest Channel (5240 MHz)**

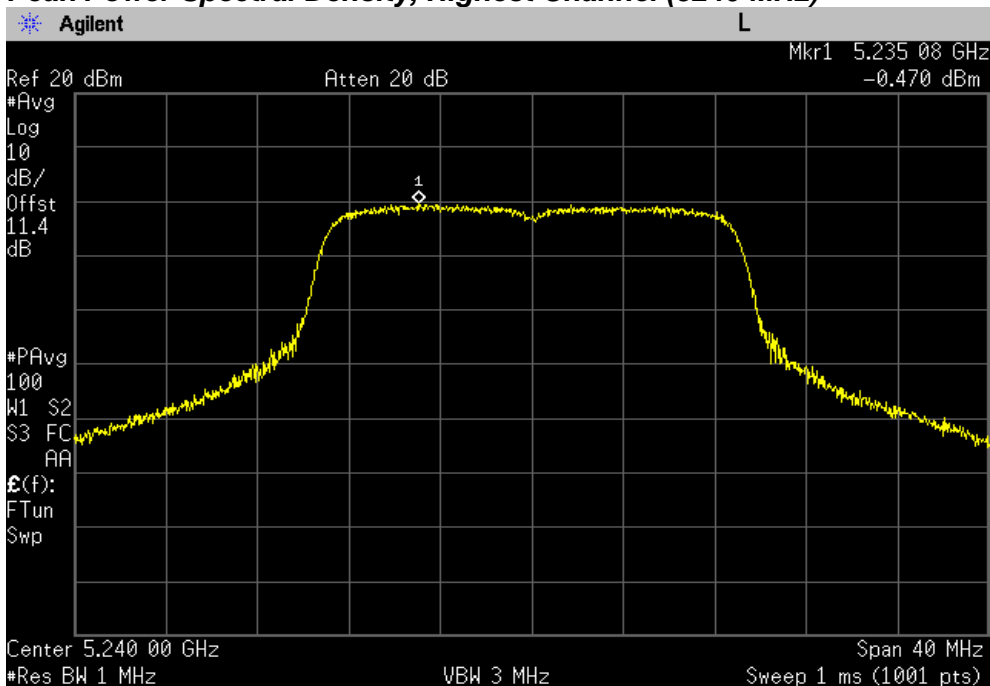

**Chain 1**

**Peak Power Spectral Density, Lowest Channel (5180 MHz)**

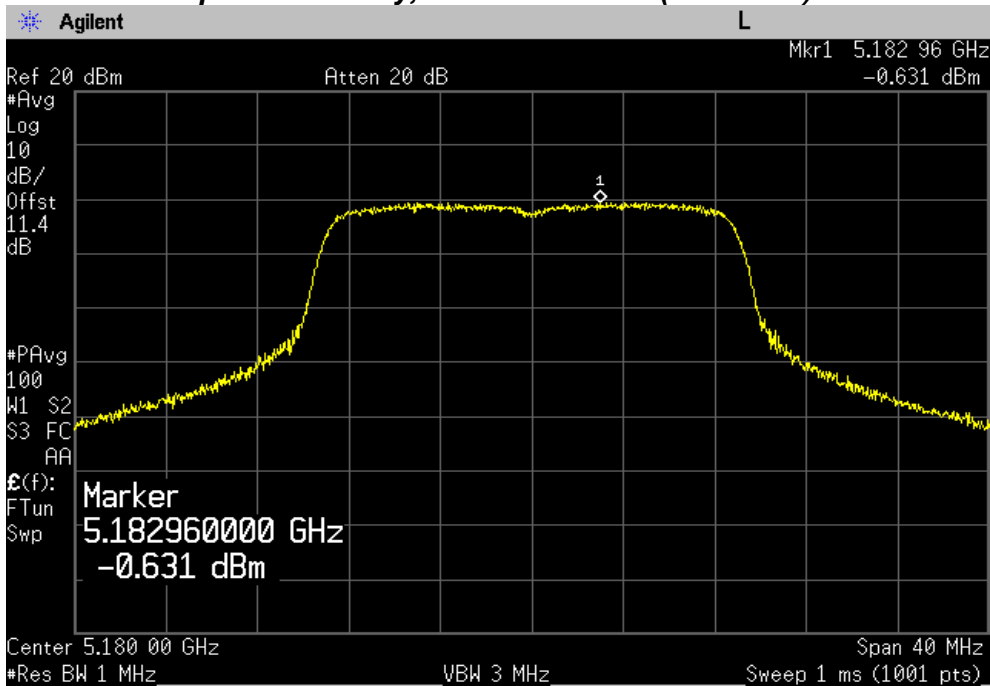

# PLOT OF TEST DATA

**Peak Power Spectral Density, Middle Channel (5200 MHz)**

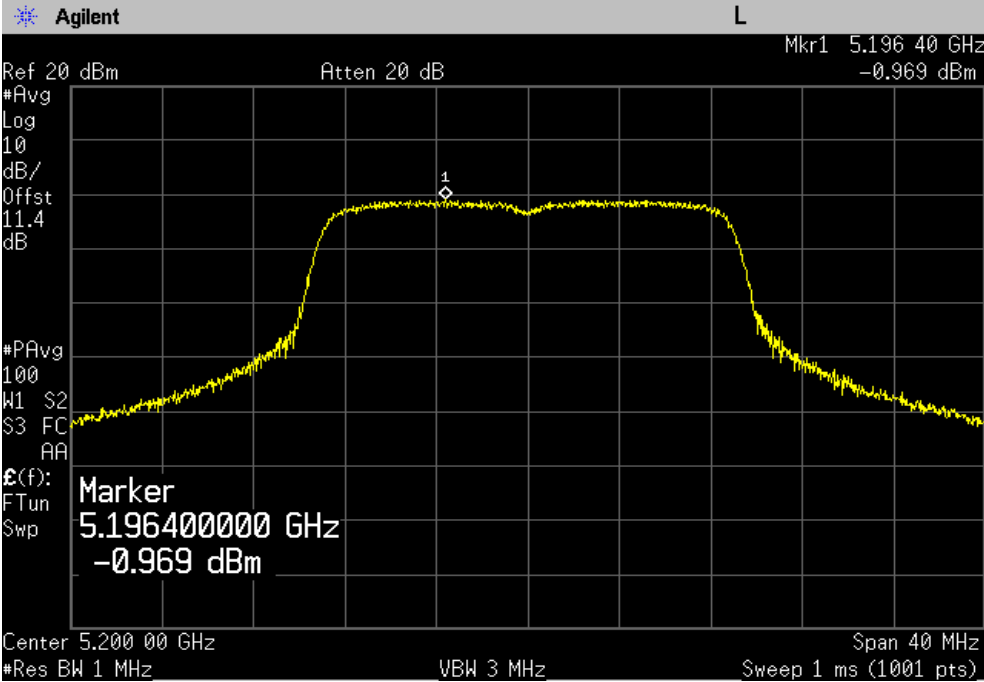

**Peak Power Spectral Density, Highest Channel (5240 MHz)**

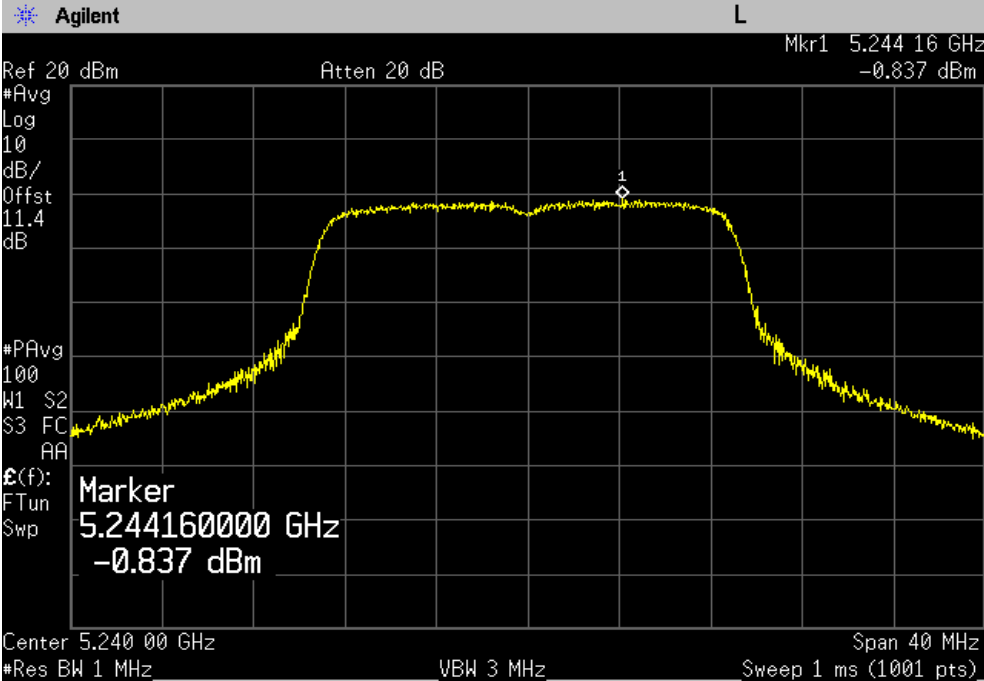

# PLOT OF TEST DATA

**802.11n(40 MHz) mode**

**Chain 0**

**Peak Power Spectral Density, Lowest Channel (5190 MHz)**

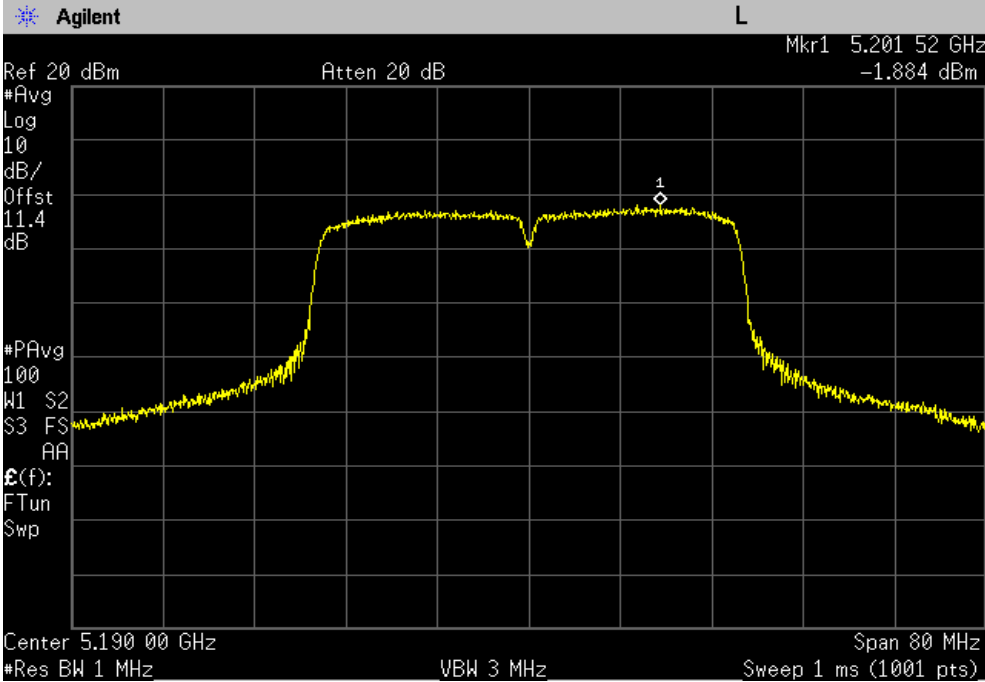

**Peak Power Spectral Density, Highest Channel (5230 MHz)**

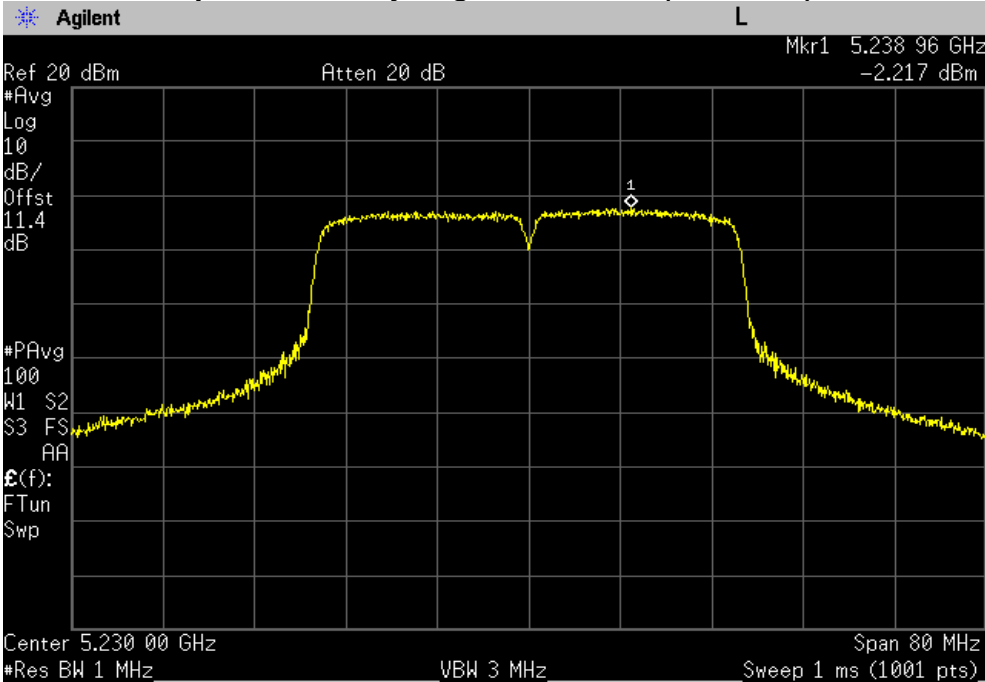

# PLOT OF TEST DATA

**Chain 1**

**Peak Power Spectral Density, Lowest Channel (5190 MHz)**

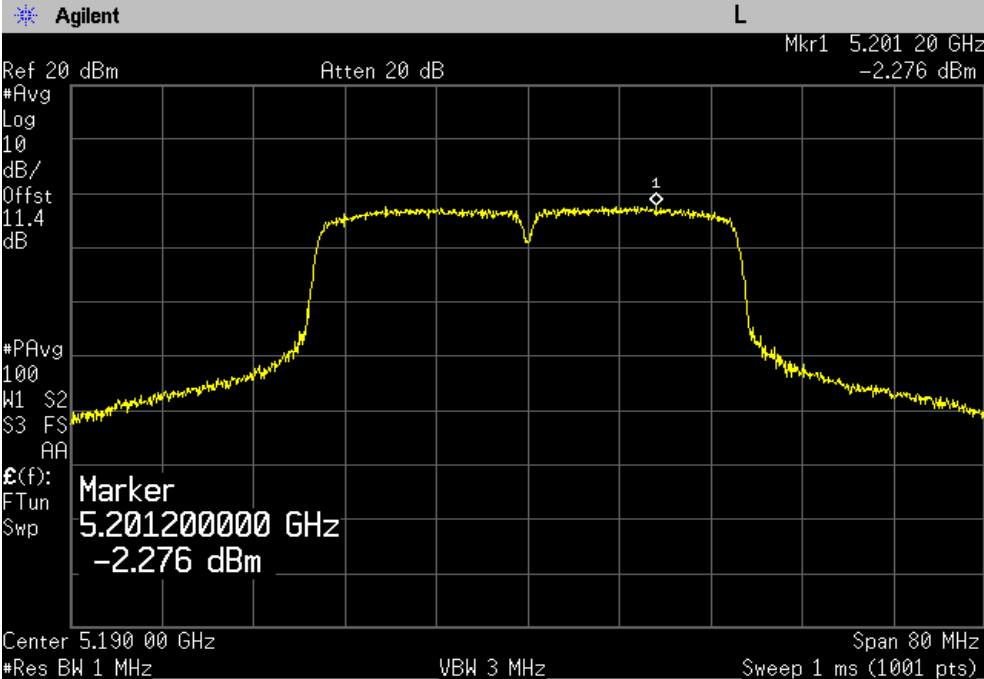

**Peak Power Spectral Density, Highest Channel (5230 MHz)**

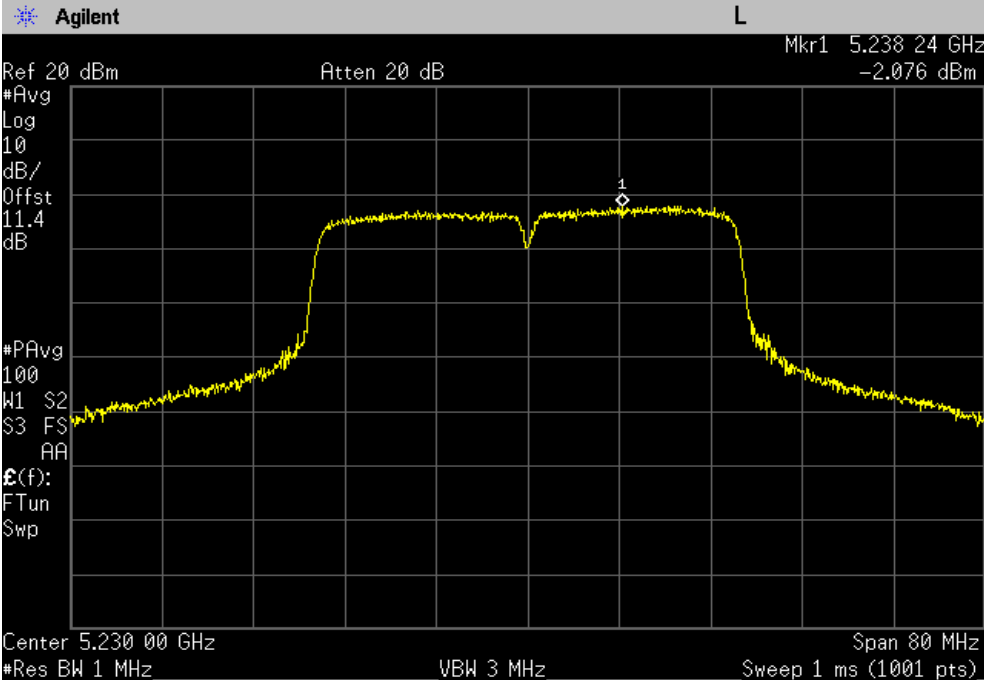

# TEST DATA

## 8.5.2 Power Spectral Density – Band II

**FCC §15.407(a), RSS-210 Issue 8, A9.2**

**Test Mode : Set to Lowest channel, Middle channel and Highest channel**

### 802.11a

Channel	Frequency(MHz)	Power Spectral Density (dBm)		Limit (dBm)
		Chain 0	Chain 1	
Low	5260	4.71	5.21	11.0
Middle	5280	3.93	4.59	11.0
High	5320	3.97	3.84	11.0

### 802.11n(20 MHz)

Channel	Frequency (MHz)	Power Spectral Density (dBm)		*Total Power Spectral Density (dBm)	Limit (dBm)
		Chain 0	Chain 1		
Low	5260	2.72	3.40	6.08	11.0
Middle	5280	2.05	2.69	5.39	11.0
High	5320	2.32	1.65	5.01	11.0

### 802.11n(40 MHz)

Channel	Frequency (MHz)	Power Spectral Density (dBm)		*Total Power Spectral Density (dBm)	Limit (dBm)
		Chain 0	Chain 1		
Low	5270	-0.51	0.30	2.92	11.0
High	5310	-1.05	-0.99	1.99	11.0

**Note:**

The following equation was used for spectrum offset:

Spectrum offset (dB) = Attenuator (dB) + Cable Loss (dB) + SMA Type Connector Loss (dB)

\*Total Peak power =  $10 \log [10^{(Chain\ 0\ Power\ density/10)} + 10^{(Chain\ 1\ Power\ density/10)}]$



# PLOT OF TEST DATA

## 802.11a mode

### Chain 0

#### Peak Power Spectral Density, Lowest Channel (5260 MHz)

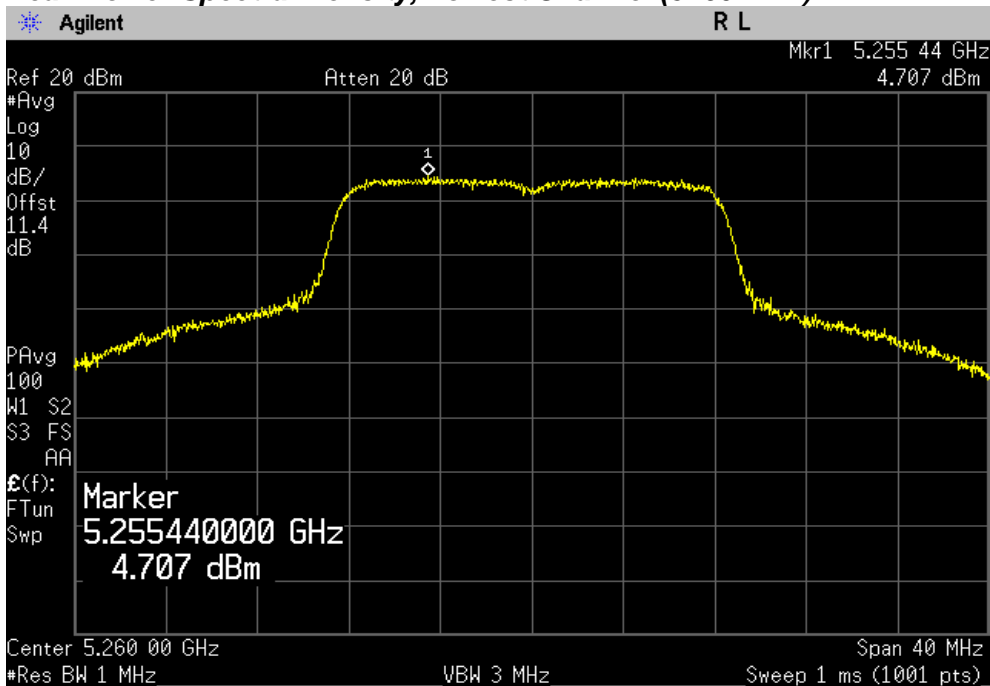

#### Peak Power Spectral Density, Middle Channel (5280 MHz)

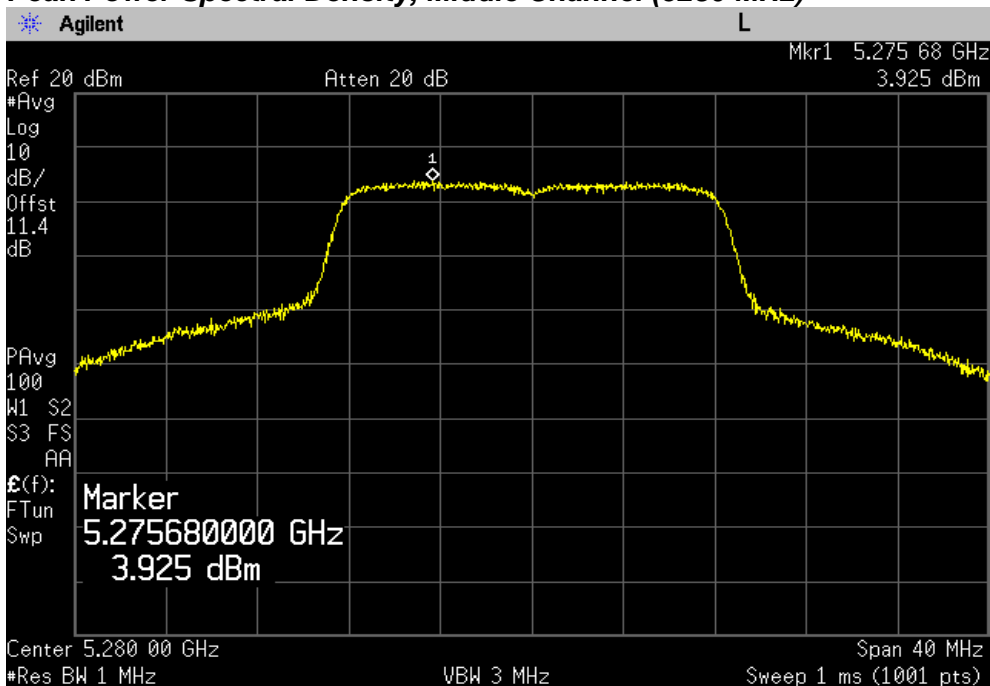

# PLOT OF TEST DATA

## Peak Power Spectral Density, Highest Channel (5320 MHz)

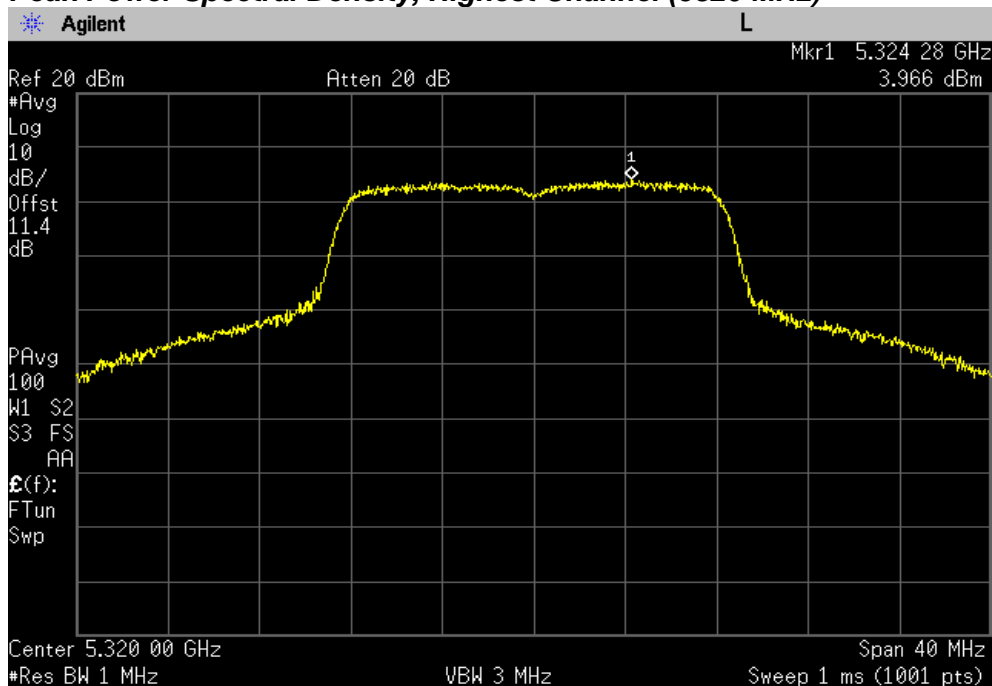

## Chain 1

## Peak Power Spectral Density, Lowest Channel (5260 MHz)

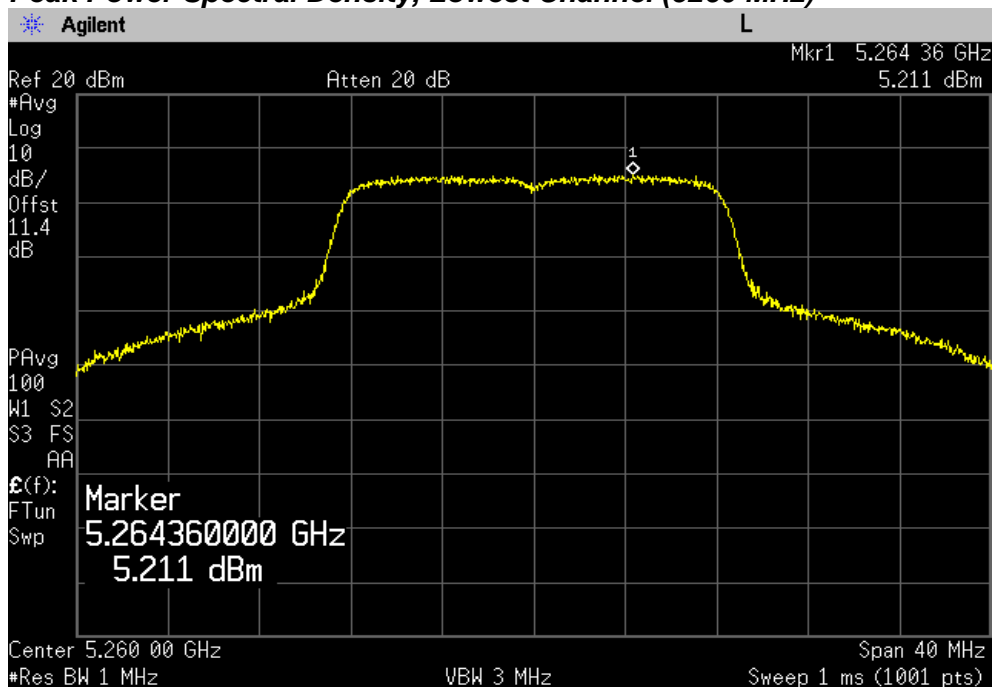

# PLOT OF TEST DATA

**Peak Power Spectral Density, Middle Channel (5280 MHz)**

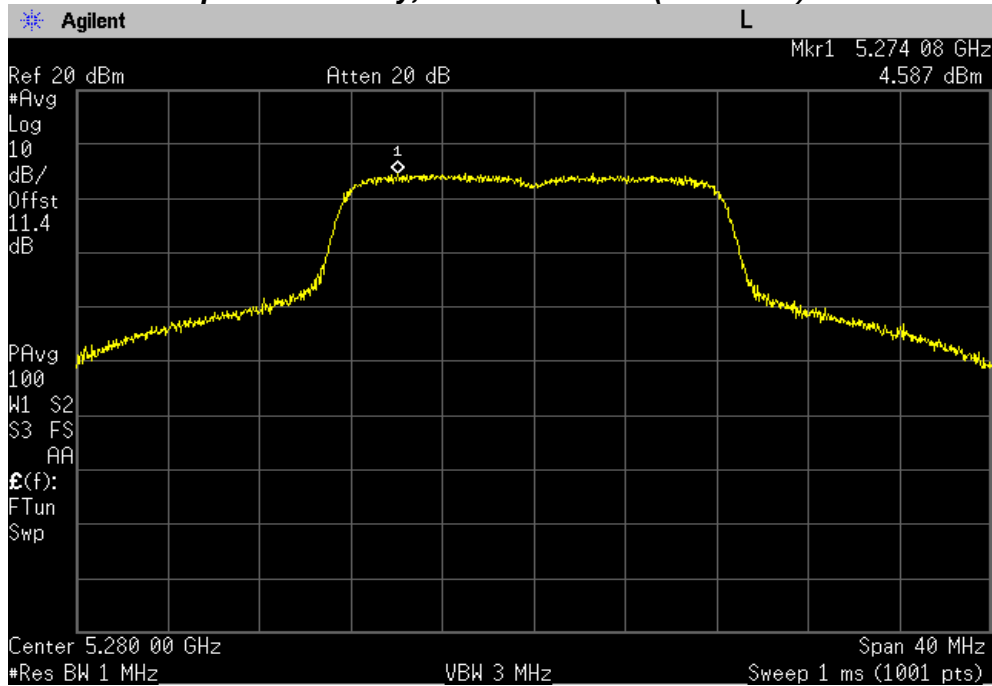

**Peak Power Spectral Density, Highest Channel (5320 MHz)**

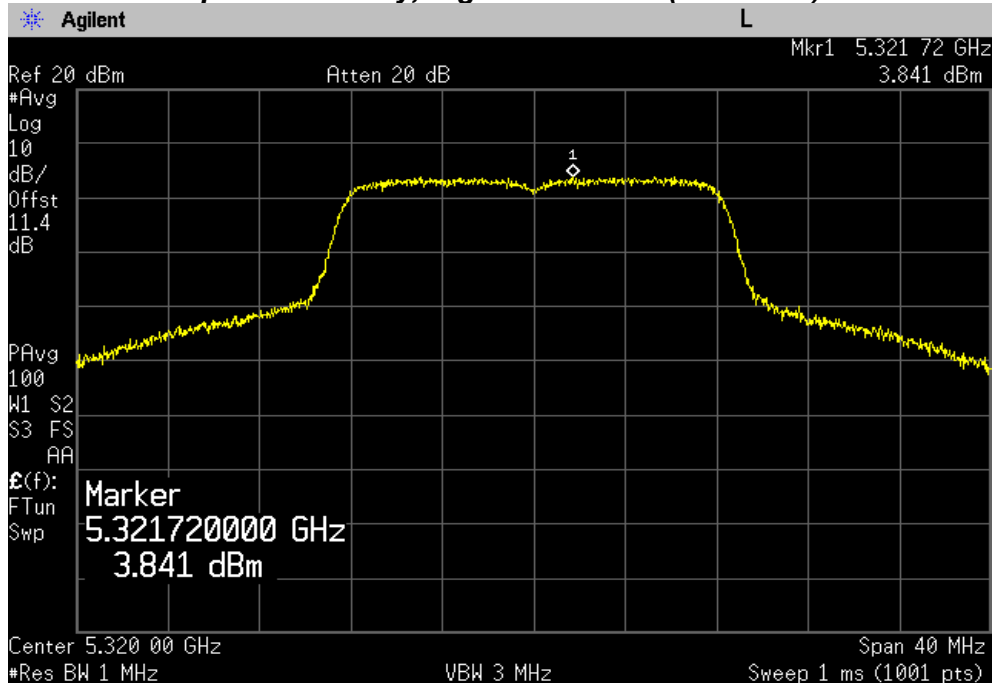

# PLOT OF TEST DATA

**802.11n(20 MHz) mode**

**Chain 0**

**Peak Power Spectral Density, Lowest Channel (5260 MHz)**

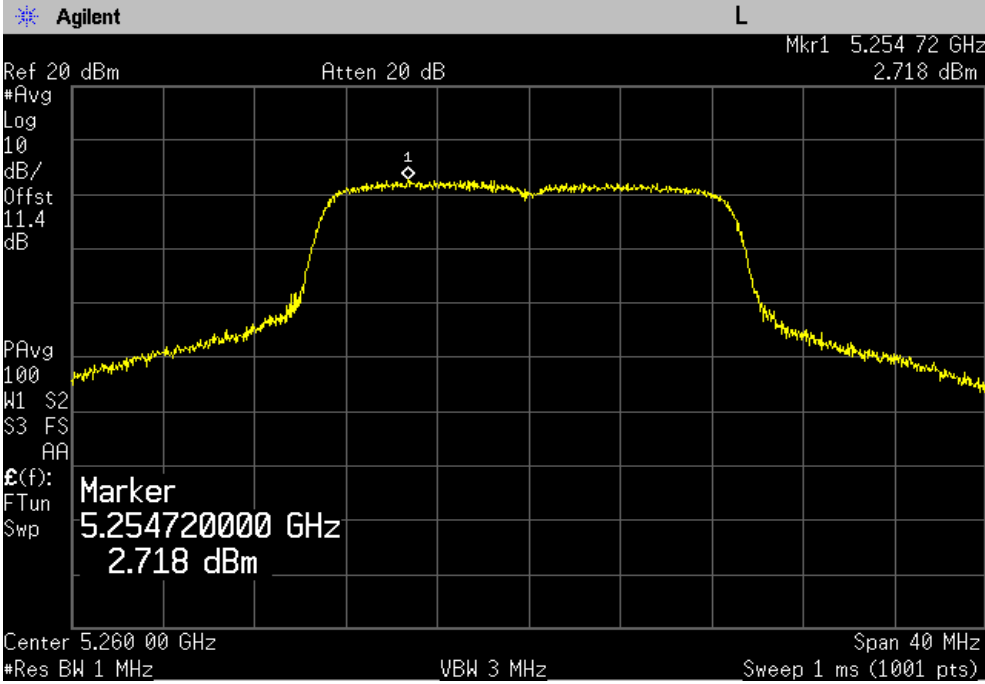

**Peak Power Spectral Density, Middle Channel (5280 MHz)**

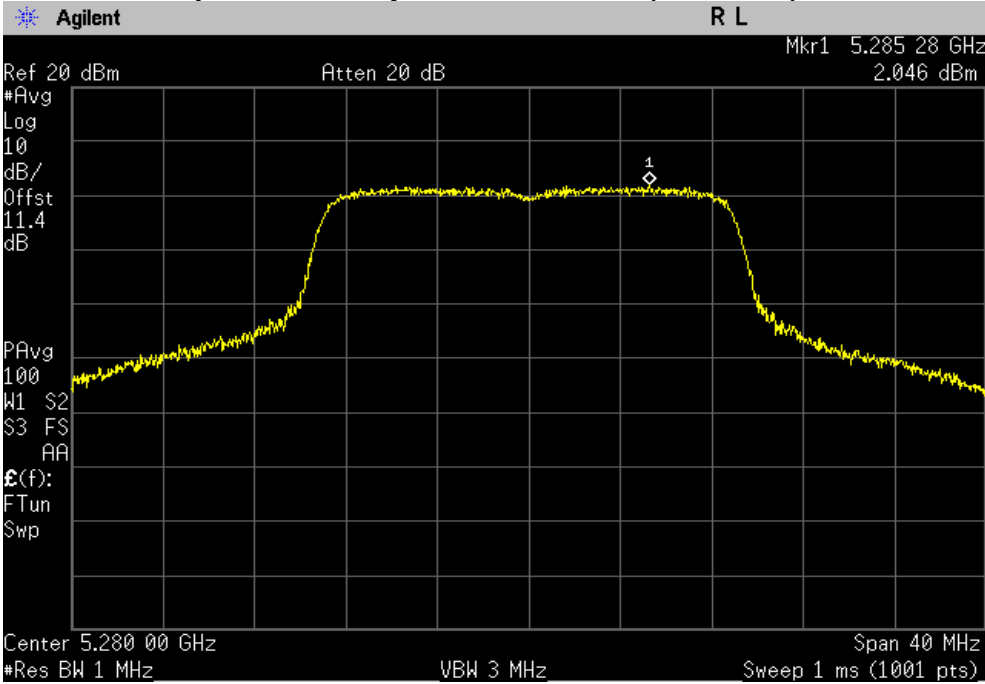

# PLOT OF TEST DATA

**Peak Power Spectral Density, Highest Channel (5320 MHz)**

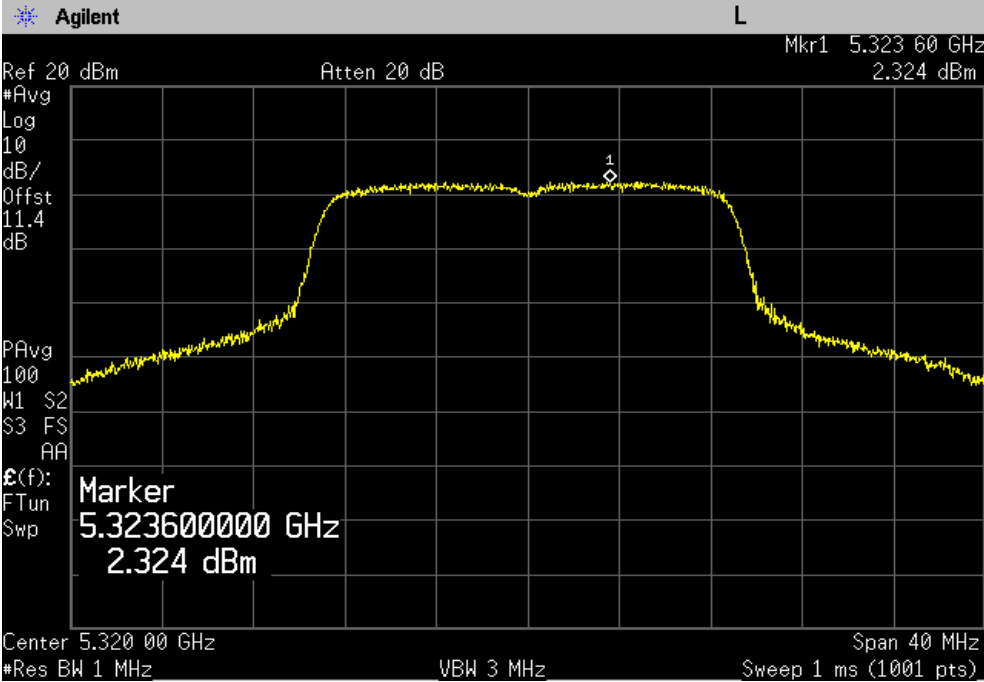

**Chain 1**

**Peak Power Spectral Density, Lowest Channel (5260 MHz)**

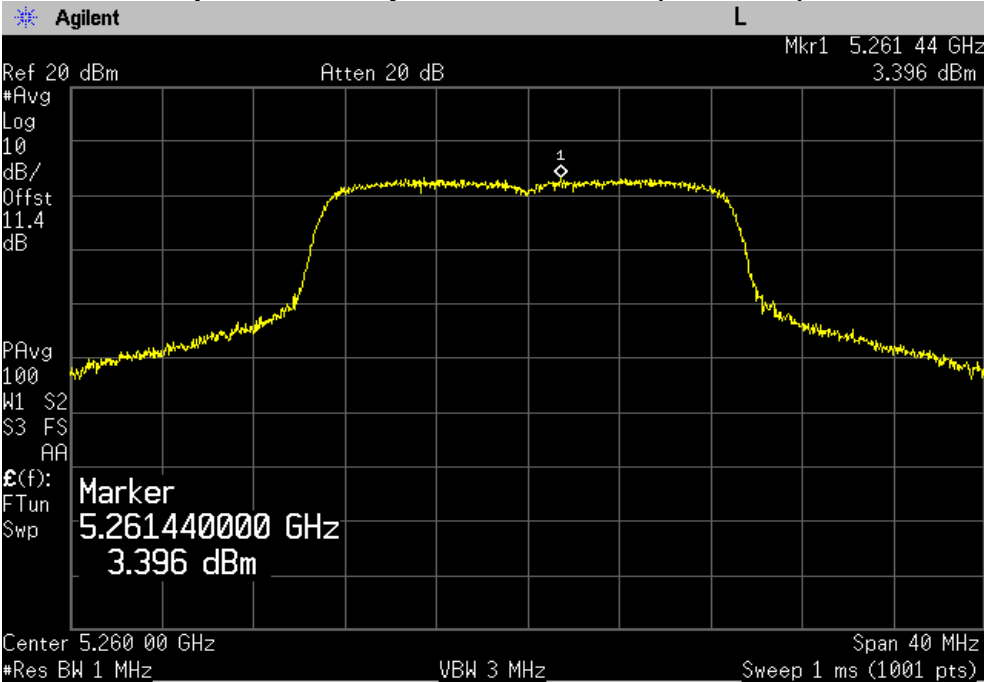

# PLOT OF TEST DATA

**Peak Power Spectral Density, Middle Channel (5280 MHz)**

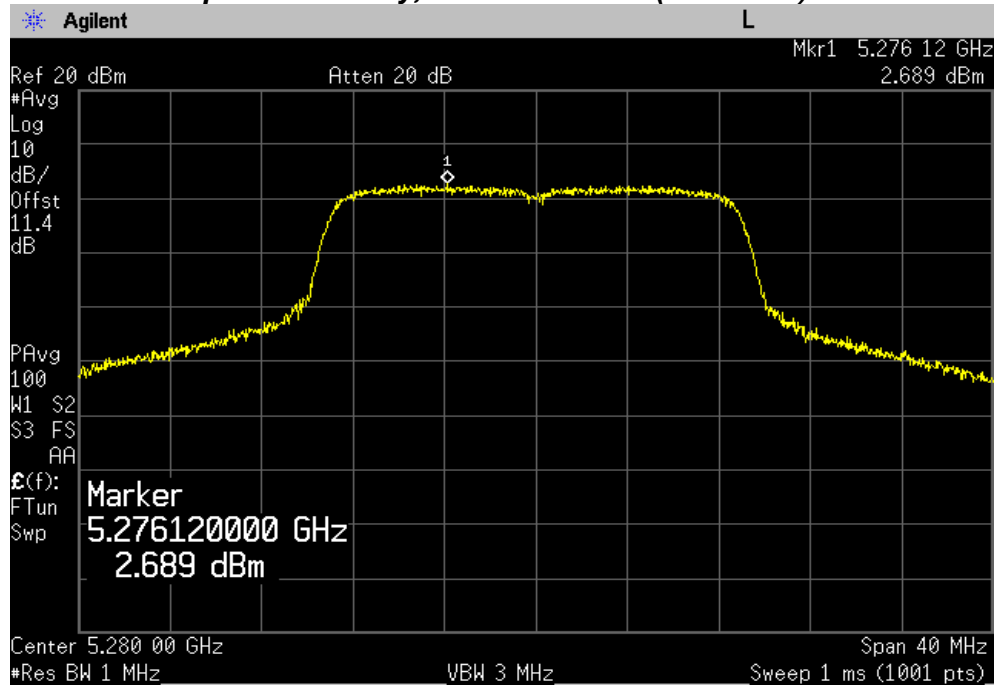

**Peak Power Spectral Density, Highest Channel (5320 MHz)**

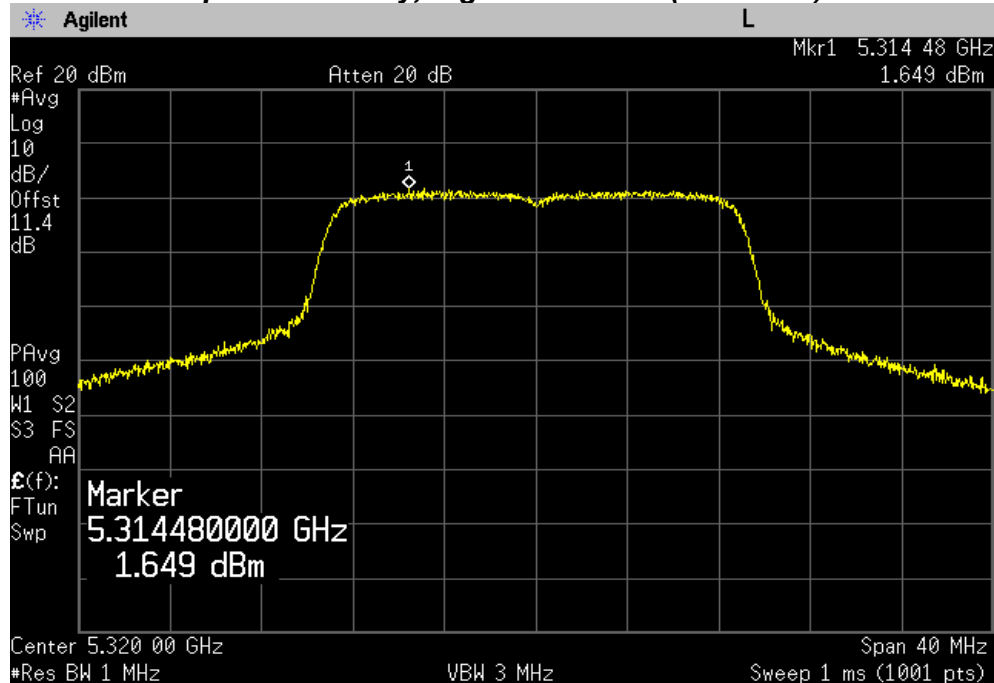

# PLOT OF TEST DATA

**802.11n(40 MHz) mode**

**Chain 0**

**Peak Power Spectral Density, Lowest Channel (5270 MHz)**

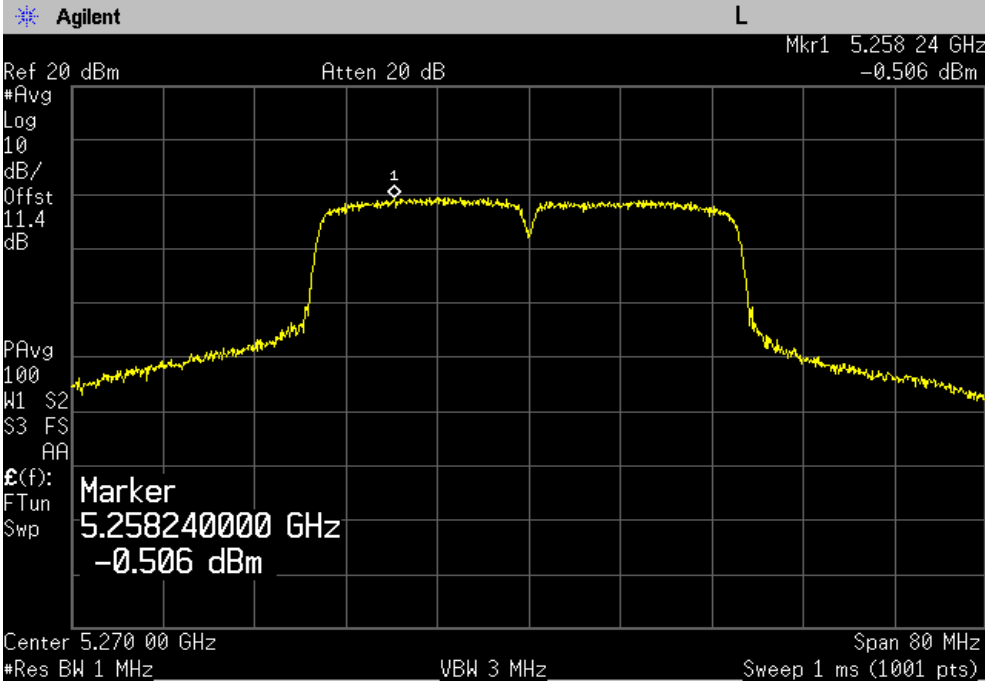

**Peak Power Spectral Density, Highest Channel (5310 MHz)**

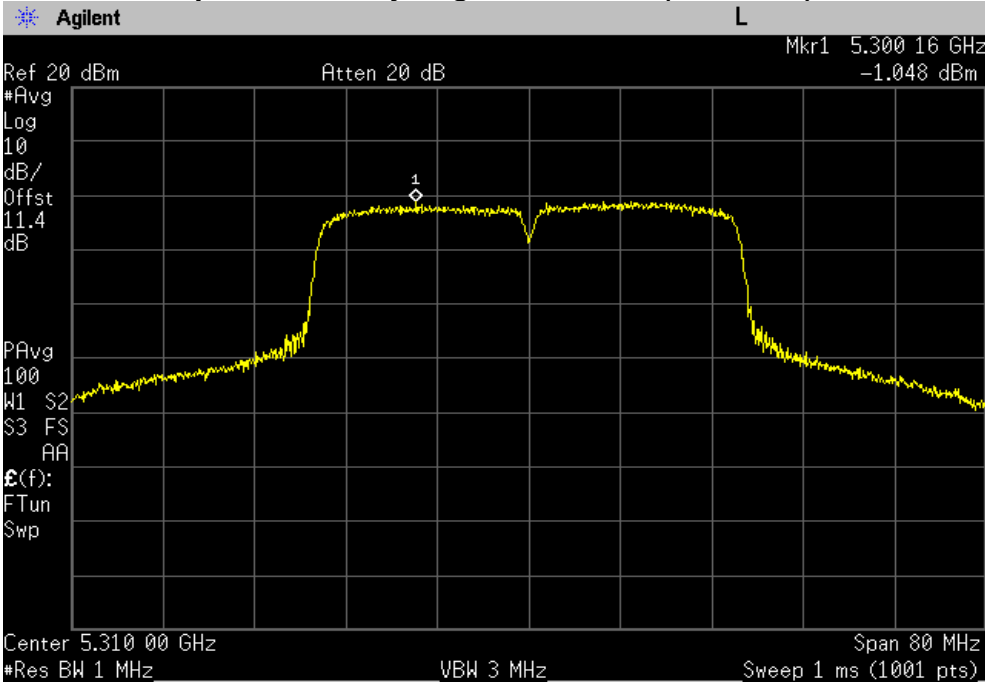

# PLOT OF TEST DATA

## Chain 1

**Peak Power Spectral Density, Lowest Channel (5270 MHz)**

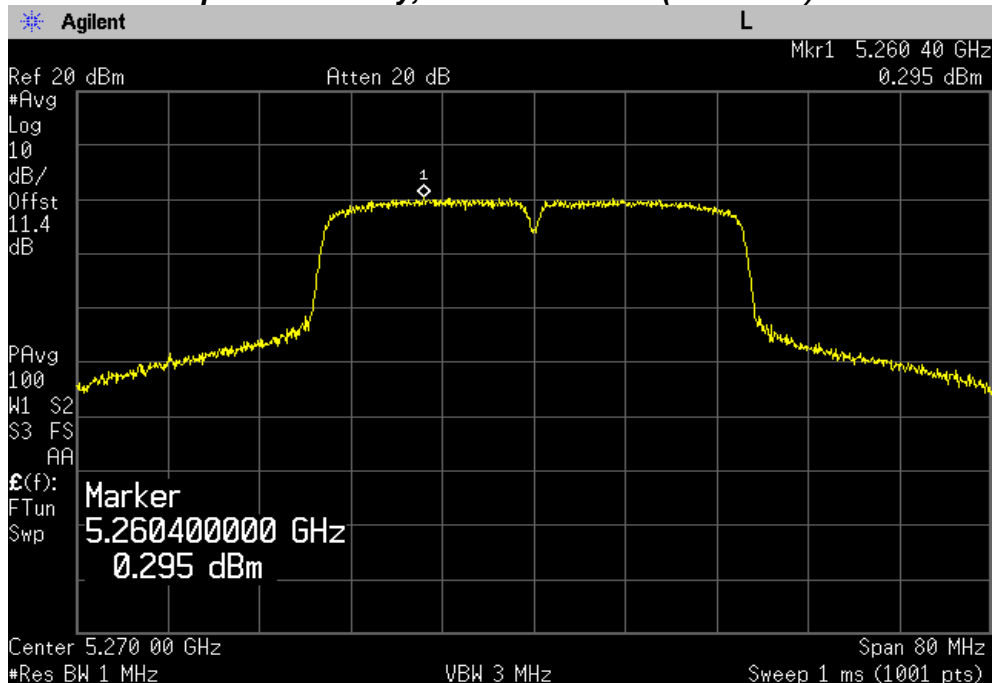

**Peak Power Spectral Density, Highest Channel (5310 MHz)**

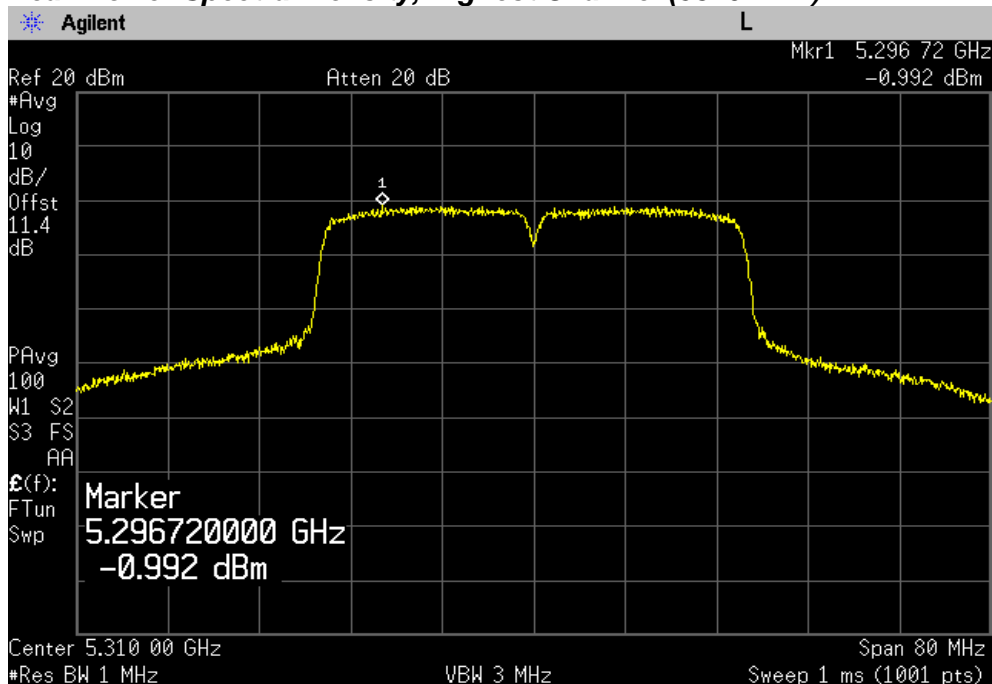



# TEST DATA

## 8.5.3 Power Spectral Density – Band III

### FCC §15.407(a), RSS-210 Issue 8, A9.2

**Test Mode : Set to Lowest channel, Middle channel and Highest channel**

#### 802.11a

Channel	Frequency(MHz)	Power Spectral Density (dBm)		Limit (dBm)
		Chain 0	Chain 1	
Low	5500	4.00	3.72	11.0
Middle	5580	4.81	5.24	11.0
High	5700	4.65	5.36	11.0

#### 802.11n(20 MHz)

Channel	Frequency (MHz)	Power Spectral Density (dBm)		*Total Power Spectral Density (dBm)	Limit (dBm)
		Chain 0	Chain 1		
Low	5500	2.54	1.87	5.23	11.0
Middle	5580	4.01	2.97	6.53	11.0
High	5700	4.31	2.61	6.55	11.0

#### 802.11n(40 MHz)

Channel	Frequency (MHz)	Power Spectral Density (dBm)		*Total Power Spectral Density (dBm)	Limit (dBm)
		Chain 0	Chain 1		
Low	5510	-3.89	-4.29	-1.08	11.0
Middle	5590	-3.04	-3.60	-0.30	11.0
High	5670	-3.11	-4.20	-0.61	11.0

**Note:**

The following equation was used for spectrum offset:

$Spectrum\ offset\ (dB) = Attenuator\ (dB) + Cable\ Loss\ (dB) + SMA\ Type\ Connector\ Loss\ (dB)$

$*Total\ Peak\ power = 10\ log\ [10^{(Chain\ 0\ Power\ density/10)} + 10^{(Chain\ 1\ Power\ density/10)}]$

# PLOT OF TEST DATA

## 802.11a mode

### Chain 0

#### Peak Power Spectral Density, Lowest Channel (5500 MHz)

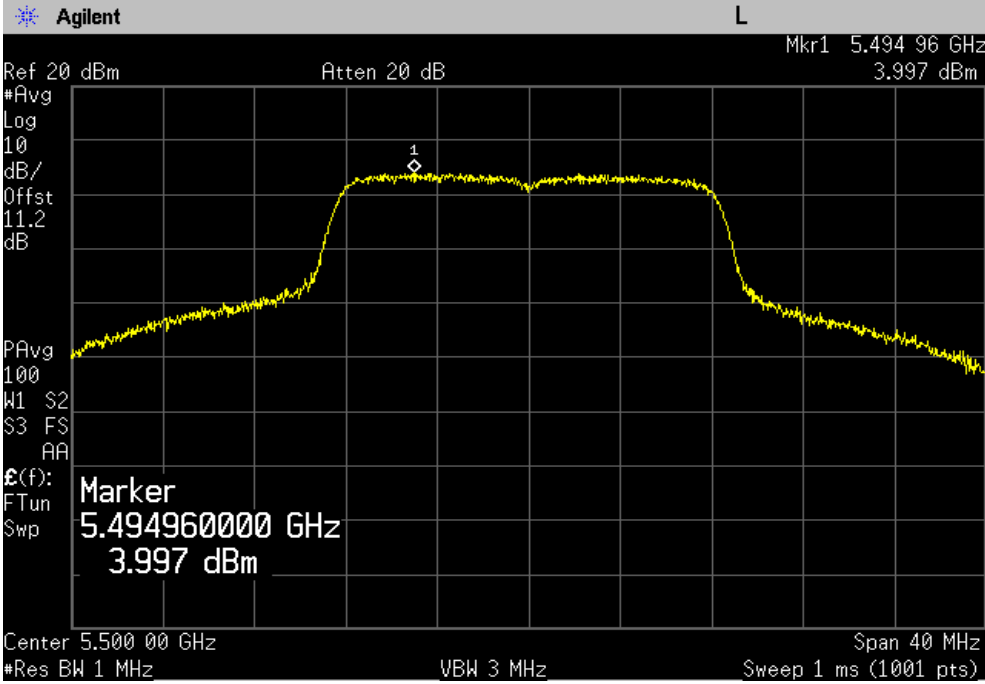

#### Peak Power Spectral Density, Middle Channel (5580 MHz)

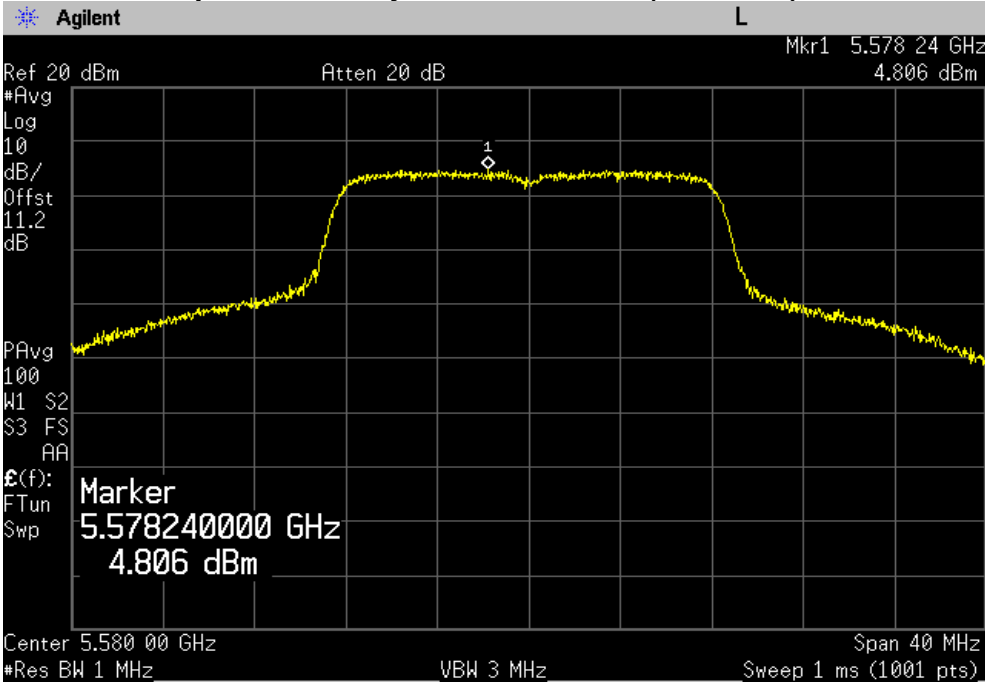

# PLOT OF TEST DATA

## Peak Power Spectral Density, Highest Channel (5700 MHz)

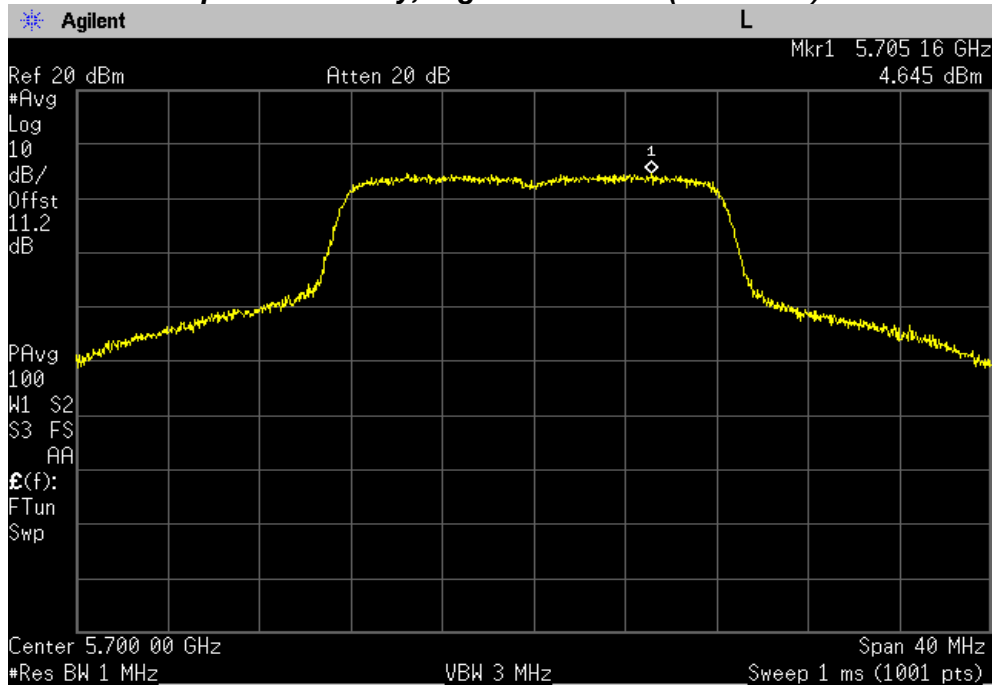

## Chain 1

## Peak Power Spectral Density, Lowest Channel (5500 MHz)

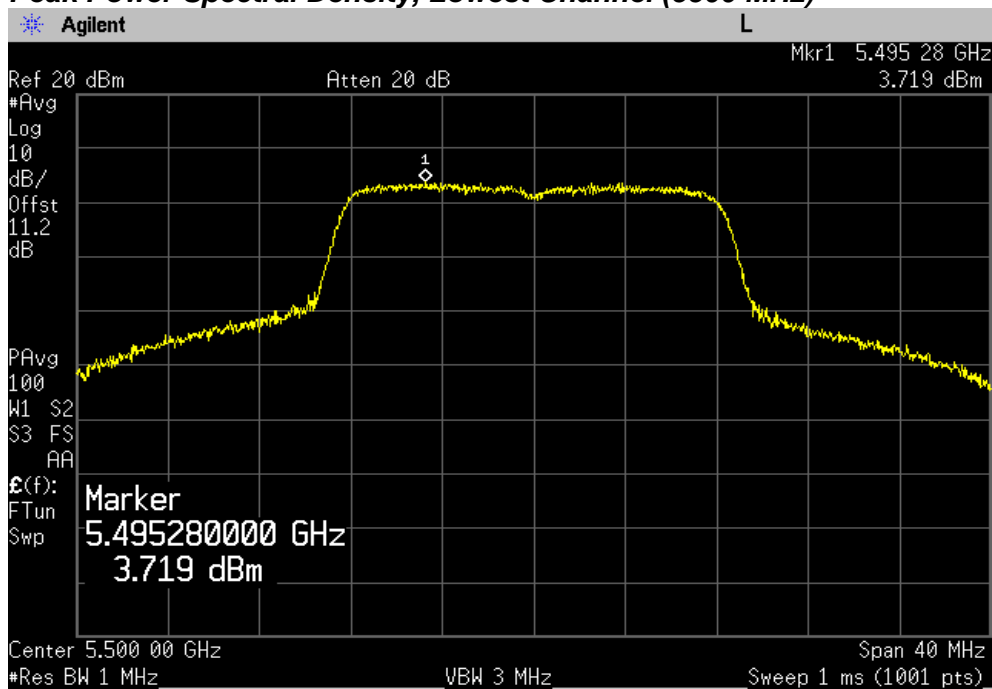

# PLOT OF TEST DATA

**Peak Power Spectral Density, Middle Channel (5580 MHz)**

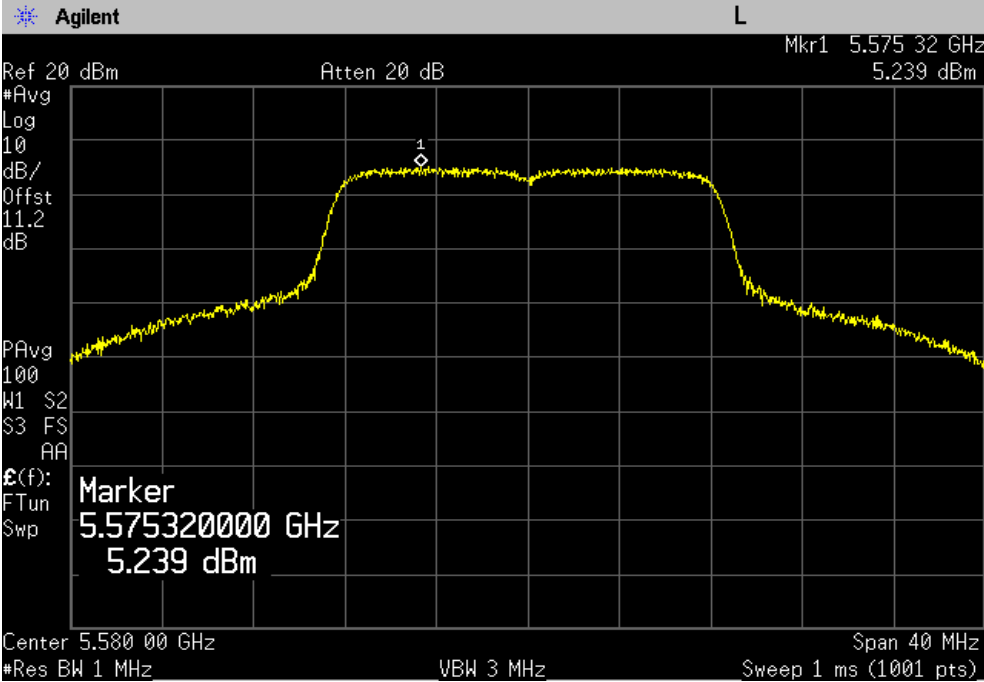

**Peak Power Spectral Density, Highest Channel (5700 MHz)**

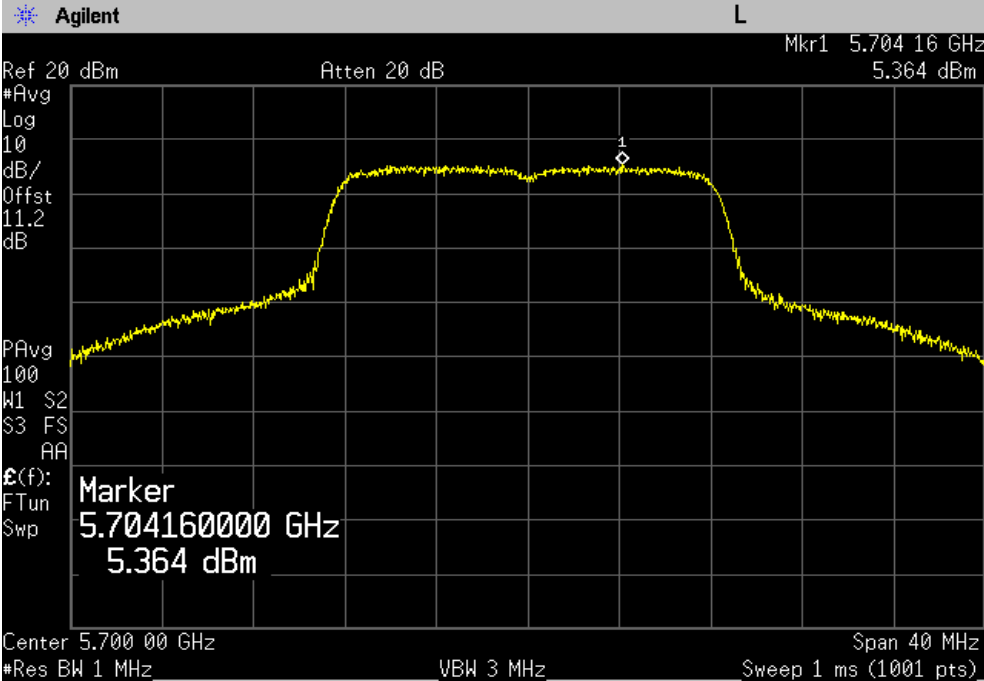

# PLOT OF TEST DATA

## 802.11n(20 MHz) mode

### Chain 0

#### Peak Power Spectral Density, Lowest Channel (5500 MHz)

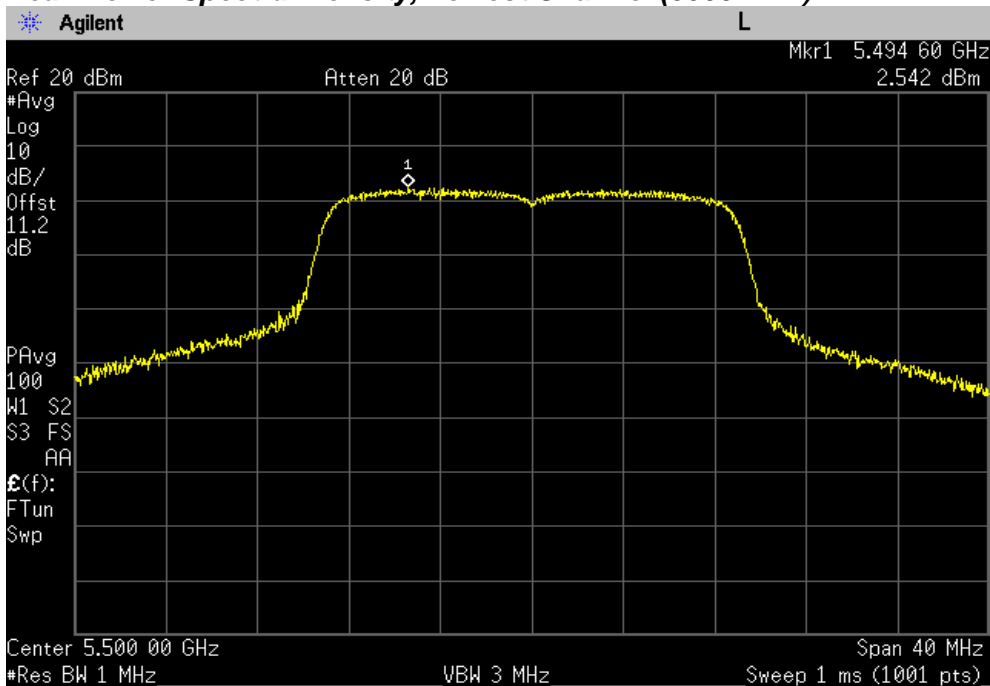

#### Peak Power Spectral Density, Middle Channel (5580 MHz)

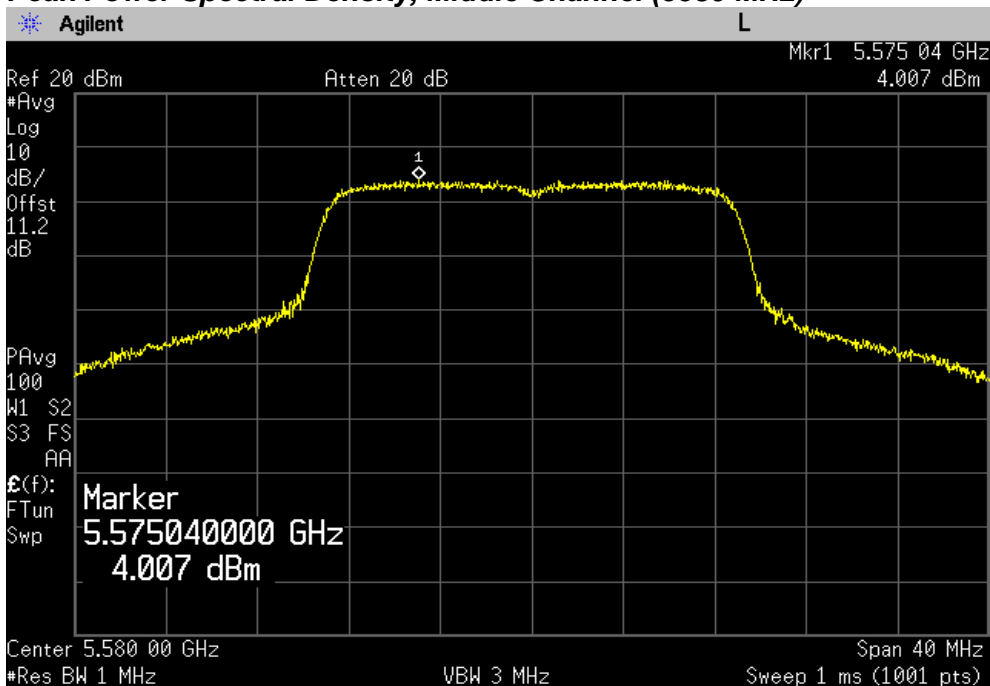

# PLOT OF TEST DATA

**Peak Power Spectral Density, Highest Channel (5700 MHz)**

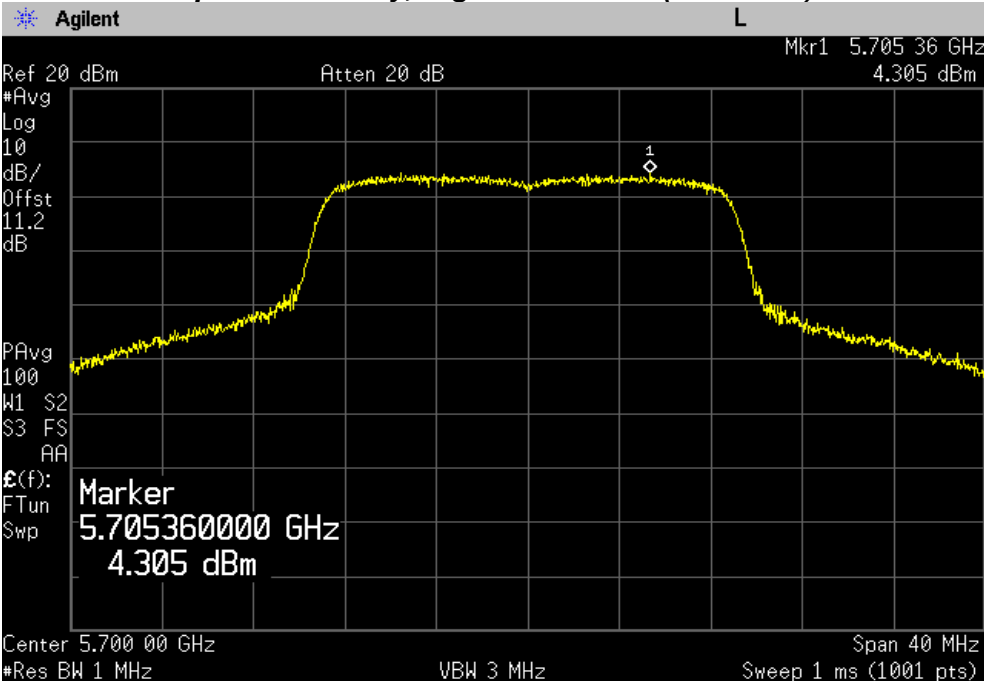

**Chain 1**

**Peak Power Spectral Density, Lowest Channel (5500 MHz)**

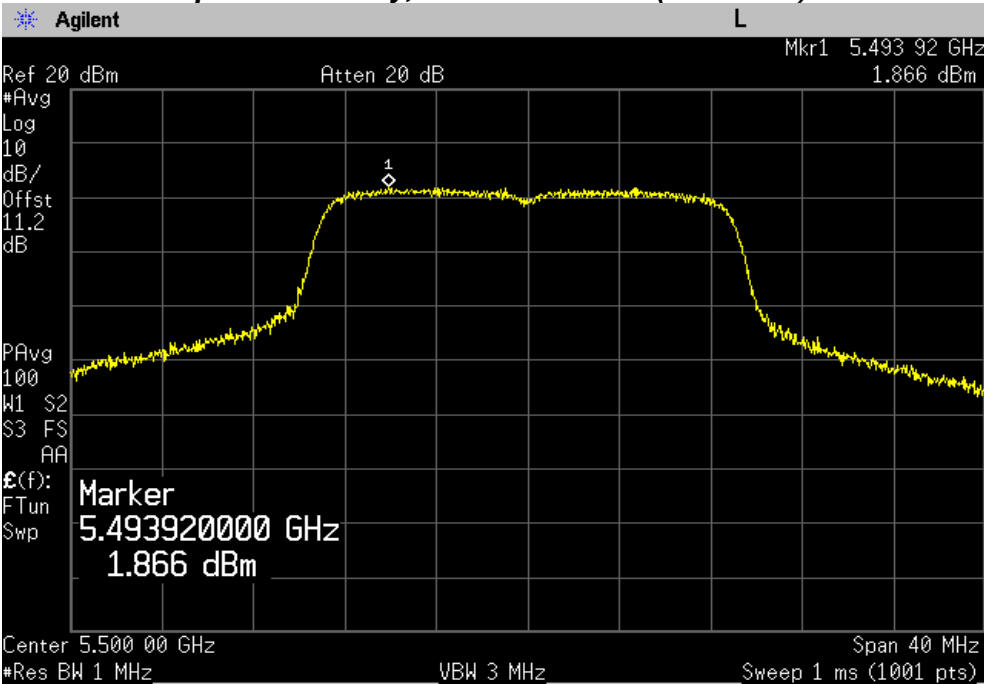

# PLOT OF TEST DATA

**Peak Power Spectral Density, Middle Channel (5580 MHz)**

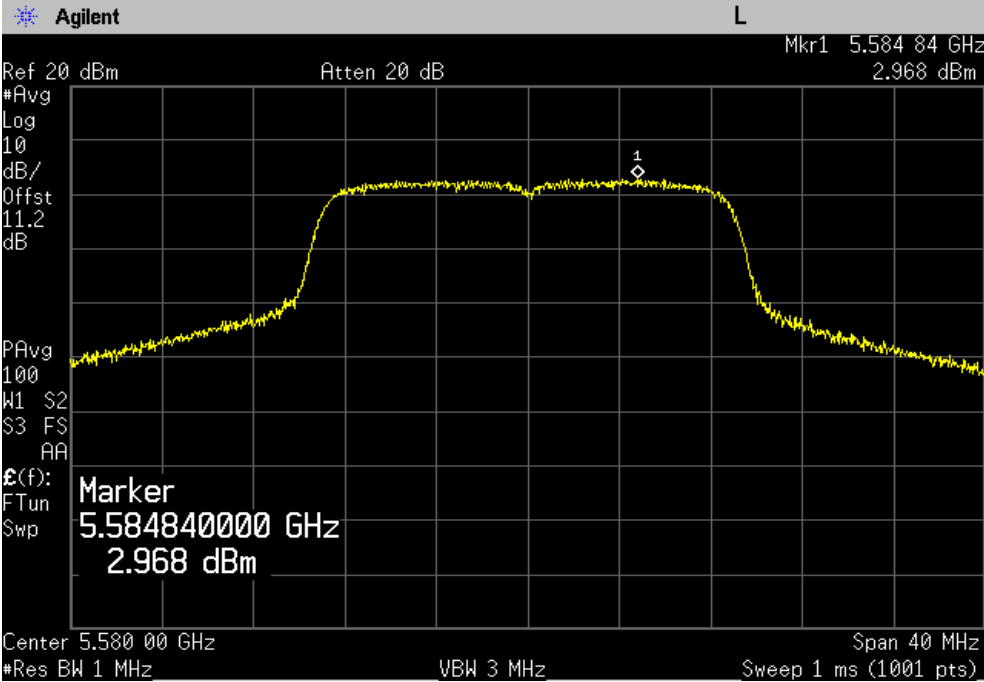

**Peak Power Spectral Density, Highest Channel (5700 MHz)**

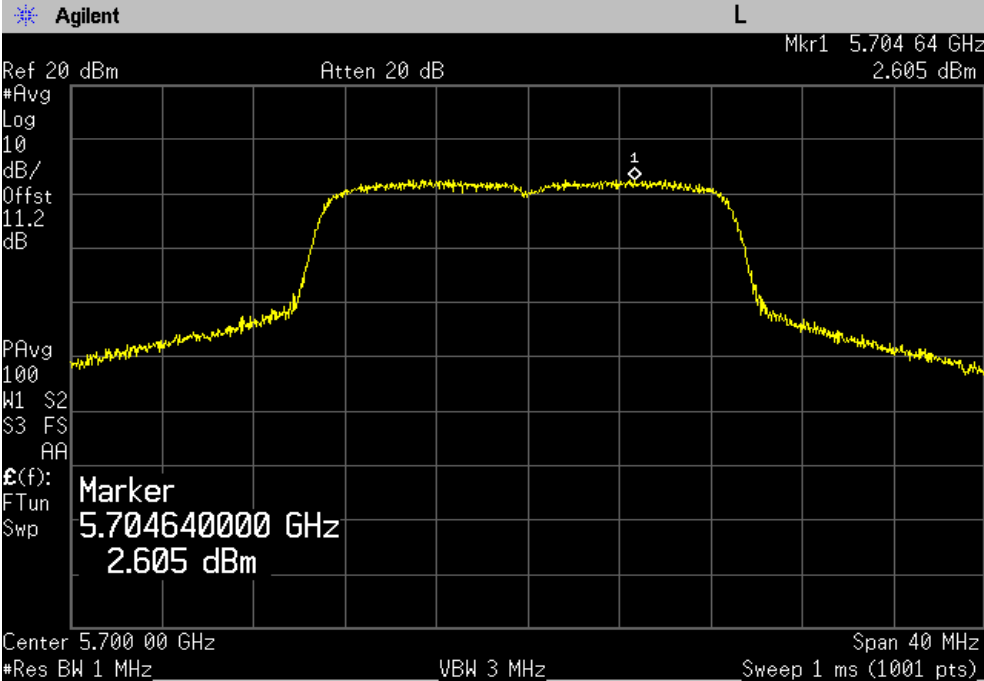

# PLOT OF TEST DATA

**802.11n(40 MHz) mode**

**Chain 0**

**Peak Power Spectral Density, Lowest Channel (5510 MHz)**

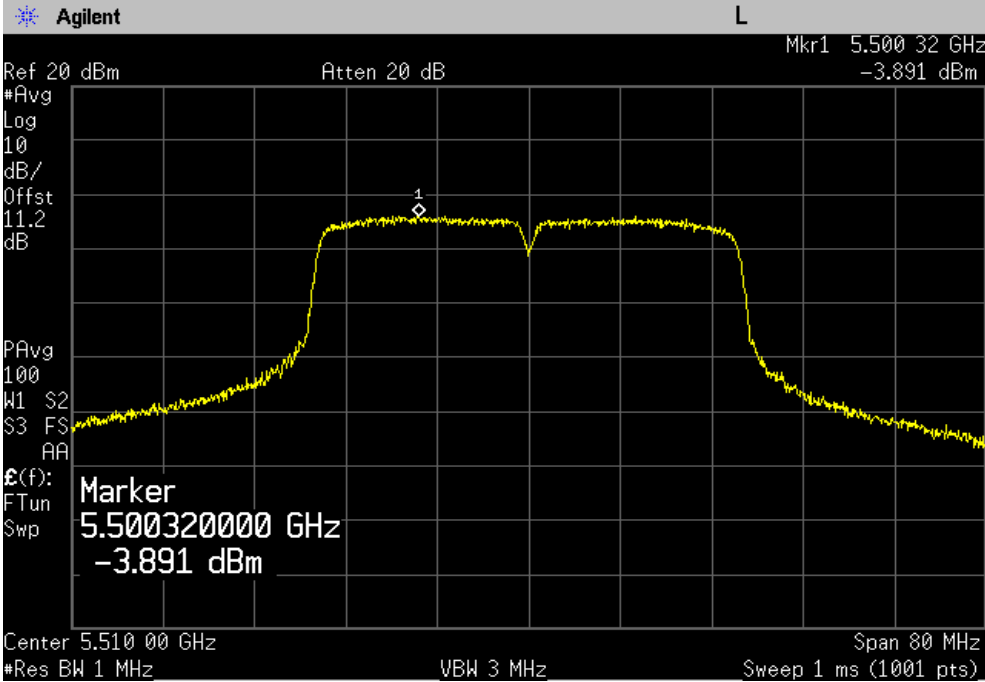

**Peak Power Spectral Density, Middle Channel (5590 MHz)**

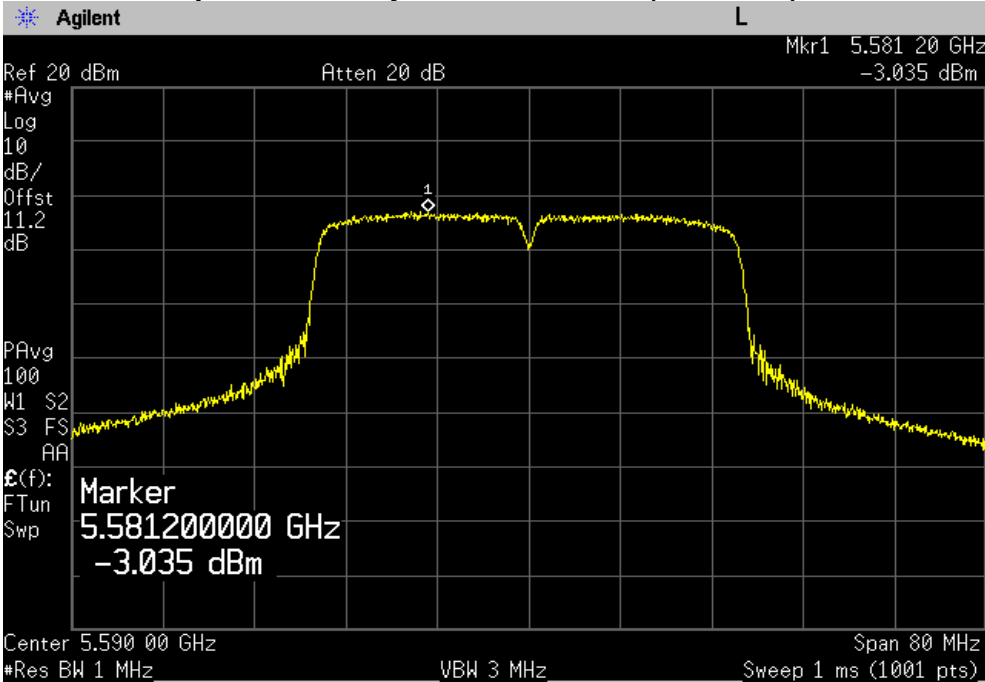



# PLOT OF TEST DATA

**Peak Power Spectral Density, Highest Channel (5670 MHz)**

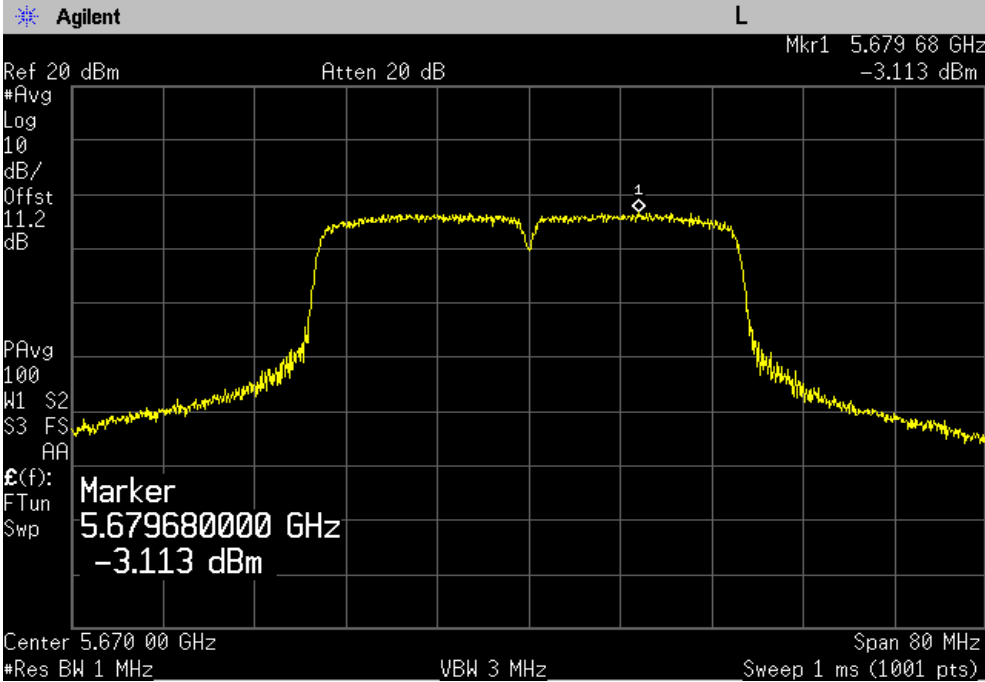

**Chain 1**

**Peak Power Spectral Density, Lowest Channel (5510 MHz)**

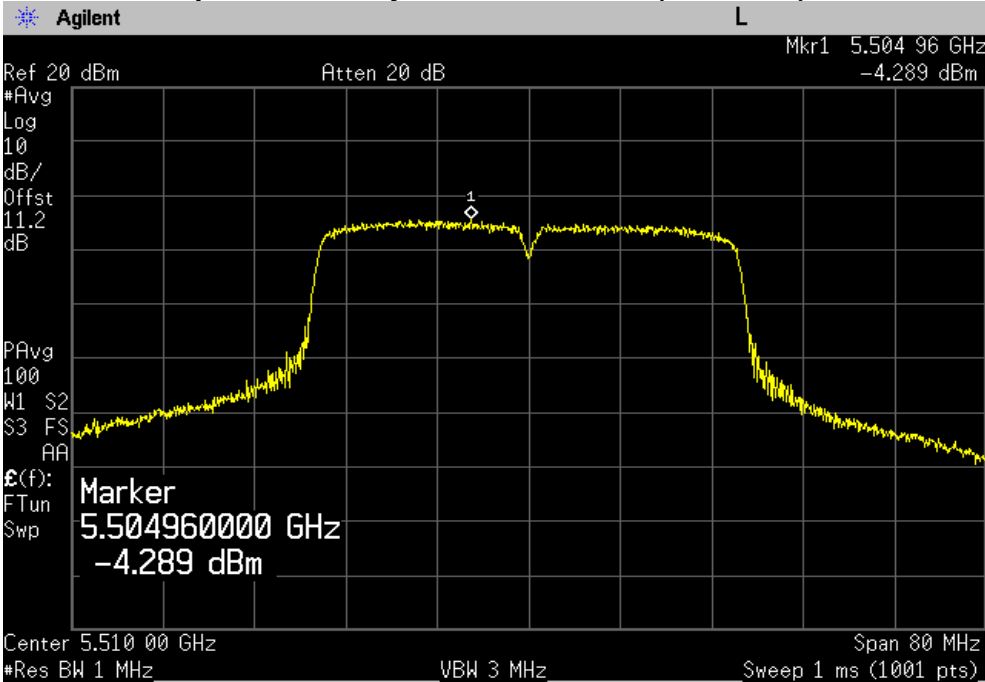

# PLOT OF TEST DATA

**Peak Power Spectral Density, Middle Channel (5590 MHz)**

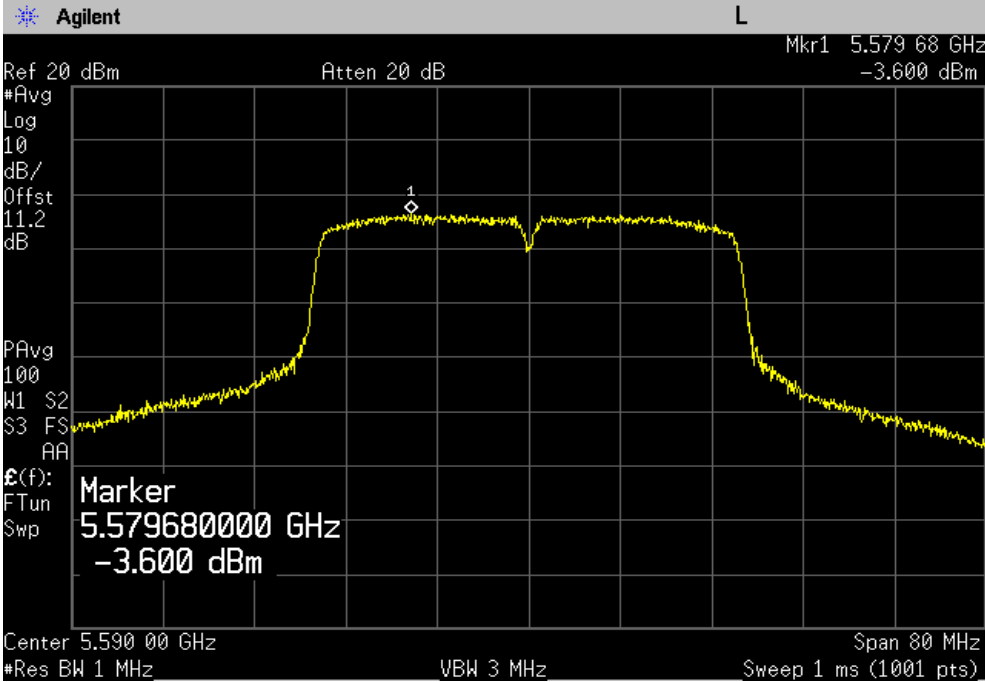

**Peak Power Spectral Density, Highest Channel (5670 MHz)**

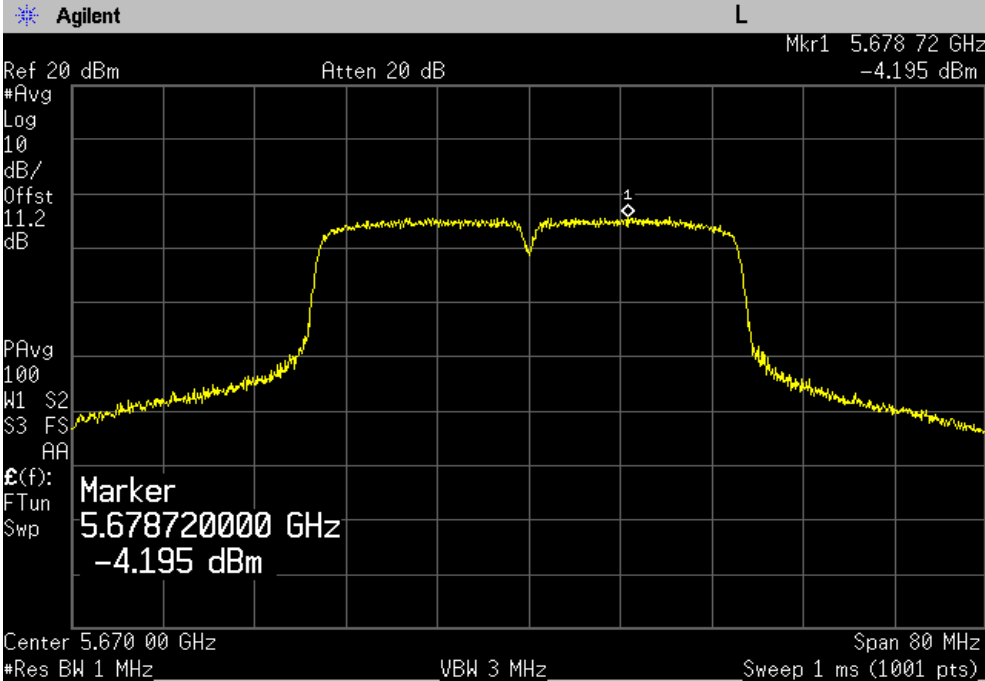

## TEST DATA

---

### 8.6 Peak Excursion

#### FCC §15.407(a)

Test Mode : Set to Lowest channel, Middle channel and Highest channel

Mode	Frequency(MHz)	Peak Excursion (dB)		Limit (dB)
		Chain 0	Chain 1	
802.11a	5180	8.44	8.38	13.0
802.11n(20 MHz)	5180	8.06	7.50	13.0
802.11n(40 MHz)	5190	7.86	7.32	13.0

# PLOT OF TEST DATA

## 802.11a mode

### Chain 0

#### Peak Excursion (5180 MHz)

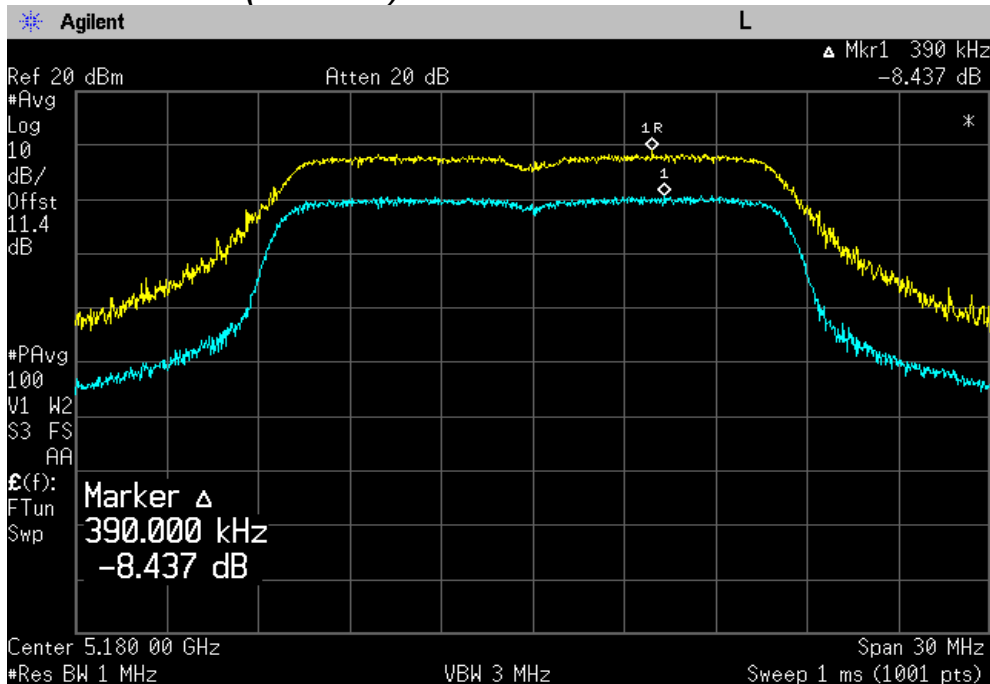

### Chain 1

#### Peak Excursion (5180 MHz)

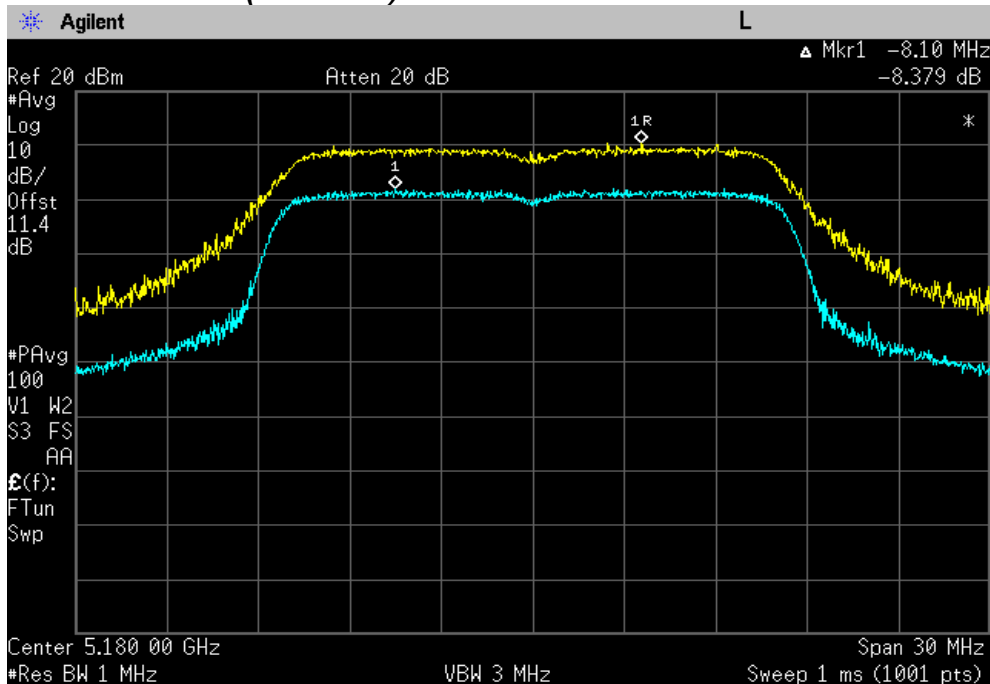

# PLOT OF TEST DATA

## 802.11n(20 MHz) mode

### Chain 0

#### **Peak Excursion (5180 MHz)**

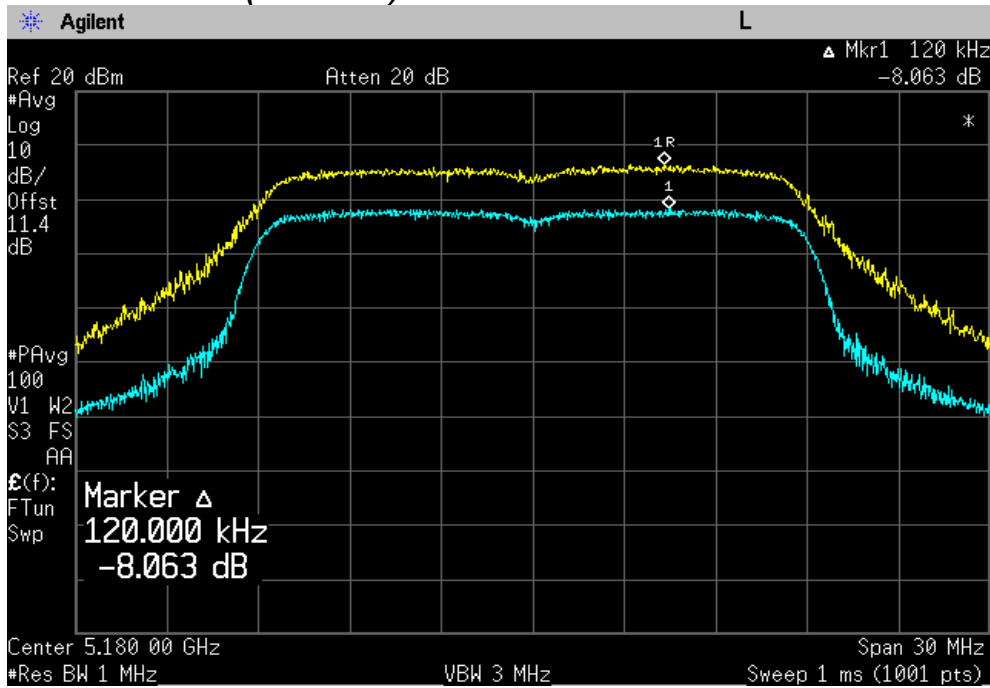

### Chain 1

#### **Peak Excursion (5180 MHz)**

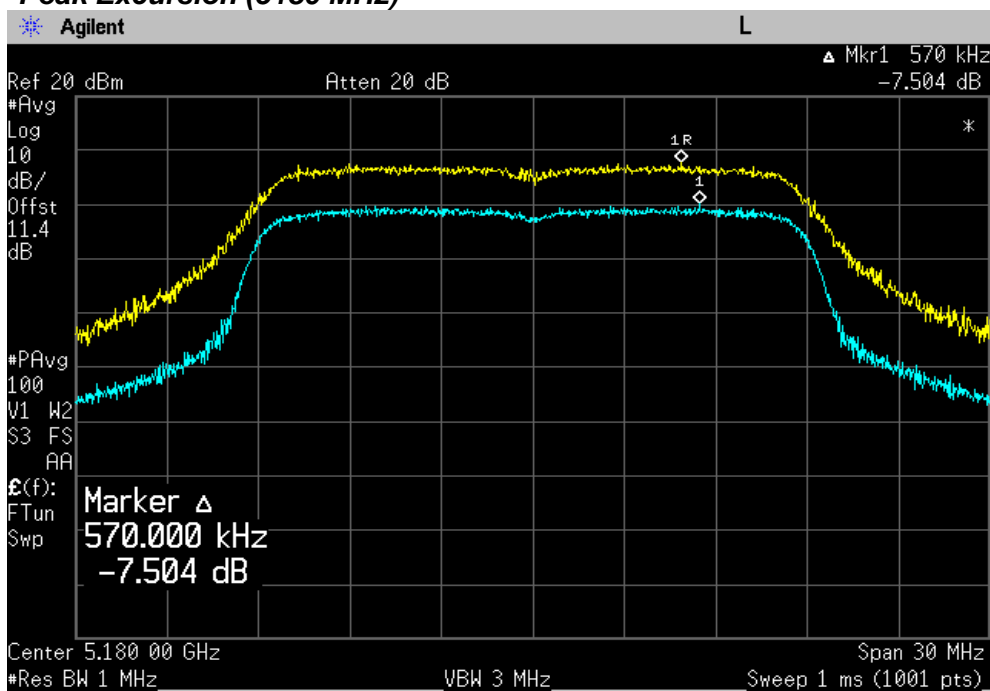

# PLOT OF TEST DATA

## 802.11n(40 MHz) mode

### Chain 0

#### **Peak Excursion (5190 MHz)**

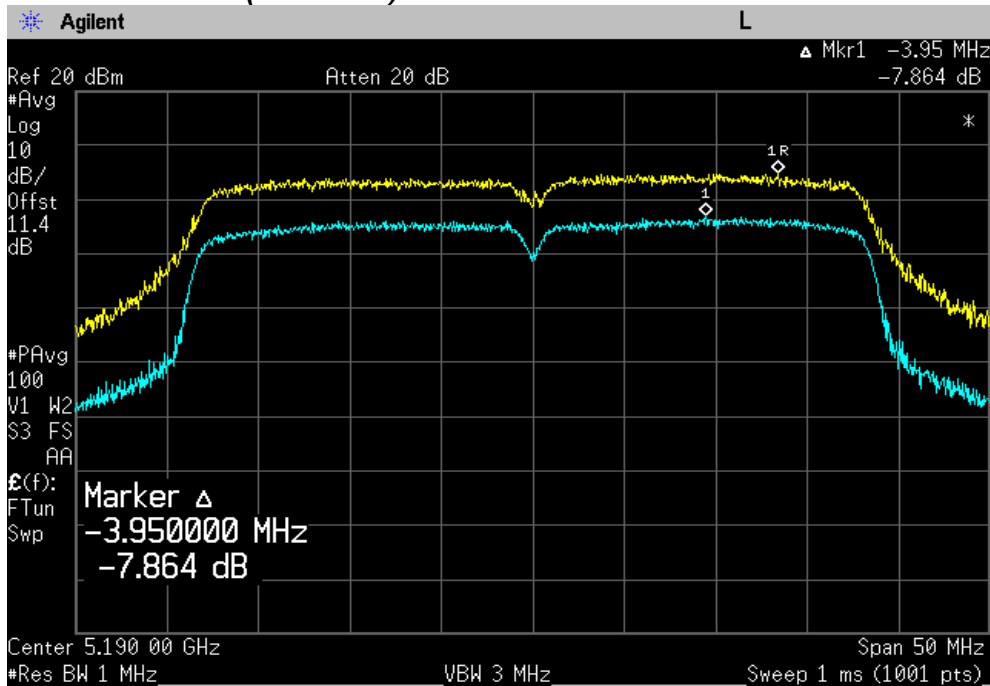

### Chain 1

#### **Peak Excursion (5190 MHz)**

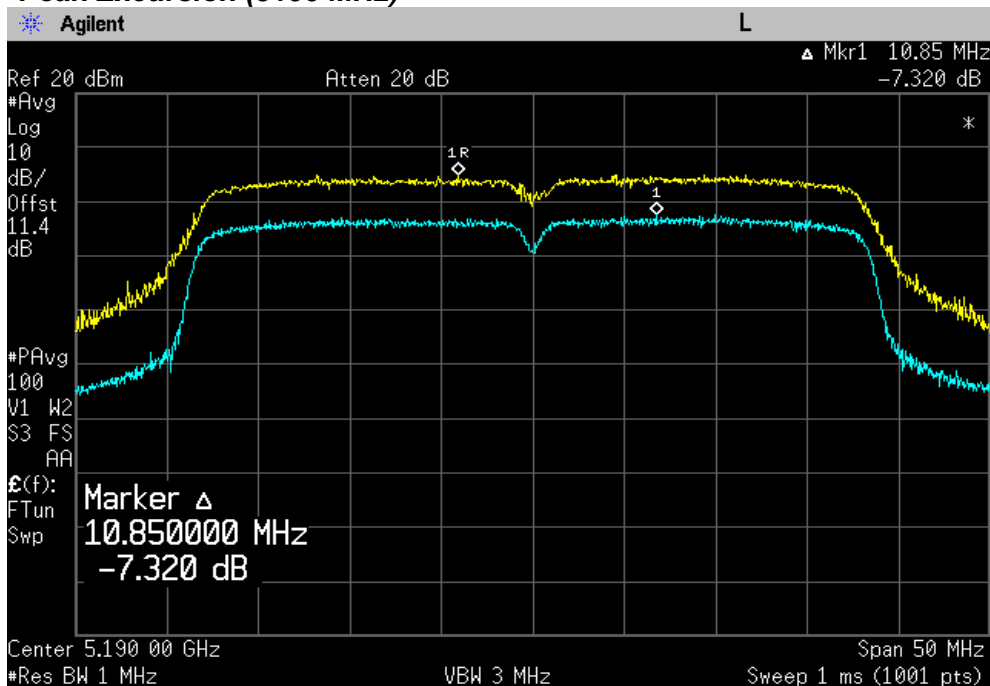

## TEST DATA

### 8.7 Radiated Spurious Emissions

#### 8.7.1 Radiated Spurious Emissions – Band I

FCC §15.407(b), RSS-210 Issue 8, A9.2

Test Mode : Set to Lowest channel, Middle channel and Highest channel

#### 802.11a mode

##### Chain 0

##### Lowest Channel (5180 MHz)

Frequency (GHz)	Reading (dBμV)	Pol* (H/V)	mode	AF+CL+Amp (dB)**	Distance (dB)***	Result (dBμV/m)	Limit (dBμV/m)	Margin (dB)
10.36	57.54	H	peak	2.55	-9.54	50.55	68.2	17.65
15.54	62.31	H	peak	2.21	-9.54	54.98	74.0	19.02
15.54	45.24	H	average	2.21	-9.54	37.91	54.0	16.09

##### Middle Channel (5200 MHz)

Frequency (GHz)	Reading (dBμV)	Pol* (H/V)	mode	AF+CL+Amp (dB)**	Distance (dB)***	Result (dBμV/m)	Limit (dBμV/m)	Margin (dB)
10.40	57.41	H	peak	2.59	-9.54	50.46	68.2	17.74
15.60	62.52	H	peak	1.91	-9.54	54.89	74.0	19.11
15.60	45.26	V	average	1.91	-9.54	37.63	54.0	16.37

##### Highest Channel (5240 MHz)

Frequency (GHz)	Reading (dBμV)	Pol* (H/V)	mode	AF+CL+Amp (dB)**	Distance (dB)***	Result (dBμV/m)	Limit (dBμV/m)	Margin (dB)
10.48	56.65	V	peak	3.08	-9.54	50.19	68.2	18.01
15.72	58.20	V	peak	1.92	-9.54	50.58	74.0	23.42
15.72	42.35	H	average	1.92	-9.54	34.73	54.0	19.27

# TEST DATA

## 802.11a mode

### Chain 1

#### Lowest Channel (5180 MHz)

Frequency (GHz)	Reading (dB $\mu$ V)	Pol* (H/V)	mode	AF+CL+Amp (dB)**	Distance (dB)***	Result (dB $\mu$ V/m)	Limit (dB $\mu$ V/m)	Margin (dB)
10.36	62.17	V	peak	2.55	-9.54	55.18	68.2	13.02
15.54	57.88	H	peak	2.21	-9.54	50.55	74.0	23.45
15.54	42.02	H	average	2.21	-9.54	34.69	54.0	19.31

#### Middle Channel (5200 MHz)

Frequency (GHz)	Reading (dB $\mu$ V)	Pol* (H/V)	mode	AF+CL+Amp (dB)**	Distance (dB)***	Result (dB $\mu$ V/m)	Limit (dB $\mu$ V/m)	Margin (dB)
10.40	60.06	V	peak	2.59	-9.54	53.11	68.2	15.09
15.60	57.97	H	peak	1.91	-9.54	50.34	74.0	23.66
15.60	41.43	H	average	1.91	-9.54	33.80	54.0	20.20

#### Highest Channel (5240 MHz)

Frequency (GHz)	Reading (dB $\mu$ V)	Pol* (H/V)	mode	AF+CL+Amp (dB)**	Distance (dB)***	Result (dB $\mu$ V/m)	Limit (dB $\mu$ V/m)	Margin (dB)
10.48	56.45	V	peak	3.08	-9.54	49.99	68.2	18.21
15.72	56.29	H	peak	1.92	-9.54	48.67	74.0	25.33
15.72	39.64	H	average	1.92	-9.54	32.02	54.0	21.98



# TEST DATA

## 802.11n(20 MHz) mode

### Chain 0 + Chain 1

#### Lowest Channel (5180 MHz)

Frequency (GHz)	Reading (dB $\mu$ V)	Pol* (H/V)	mode	AF+CL+Amp (dB)**	Distance (dB)***	Result (dB $\mu$ V/m)	Limit (dB $\mu$ V/m)	Margin (dB)
10.36	55.14	V	peak	2.55	-9.54	48.15	68.2	20.05
15.54	55.34	H	peak	2.21	-9.54	48.01	74.0	25.99
15.54	40.12	H	average	2.21	-9.54	32.79	54.0	21.21

#### Middle Channel (5200 MHz)

Frequency (GHz)	Reading (dB $\mu$ V)	Pol* (H/V)	mode	AF+CL+Amp (dB)**	Distance (dB)***	Result (dB $\mu$ V/m)	Limit (dB $\mu$ V/m)	Margin (dB)
10.40	52.80	V	peak	2.59	-9.54	45.85	68.2	22.35
15.60	54.36	H	peak	1.91	-9.54	46.73	74.0	27.27
15.60	39.75	H	average	1.91	-9.54	32.12	54.0	21.88

#### Highest Channel (5240 MHz)

Frequency (GHz)	Reading (dB $\mu$ V)	Pol* (H/V)	mode	AF+CL+Amp (dB)**	Distance (dB)***	Result (dB $\mu$ V/m)	Limit (dB $\mu$ V/m)	Margin (dB)
10.48	51.96	V	peak	3.08	-9.54	45.50	68.2	22.70
15.72	53.31	V	peak	1.92	-9.54	45.69	74.0	28.31
15.72	39.39	H	average	1.92	-9.54	31.77	54.0	22.23

# TEST DATA

## 802.11n(40 MHz) mode

### Chain 0 + Chain 1

#### Lowest Channel (5190 MHz)

Frequency (GHz)	Reading (dB $\mu$ V)	Pol* (H/V)	mode	AF+CL+Amp (dB)**	Distance (dB)***	Result (dB $\mu$ V/m)	Limit (dB $\mu$ V/m)	Margin (dB)
10.38	52.80	V	peak	2.86	-9.54	46.12	68.2	22.08
15.57	54.75	V	peak	2.27	-9.54	47.48	74.0	26.52
15.57	39.27	V	average	2.27	-9.54	32.00	54.0	22.00

#### Highest Channel (5230 MHz)

Frequency (GHz)	Reading (dB $\mu$ V)	Pol* (H/V)	mode	AF+CL+Amp (dB)**	Distance (dB)***	Result (dB $\mu$ V/m)	Limit (dB $\mu$ V/m)	Margin (dB)
10.46	50.11	H	peak	3.09	-9.54	43.66	68.2	24.54
15.69	53.25	V	peak	1.54	-9.54	45.25	74.0	28.75
15.69	38.66	V	average	1.54	-9.54	30.66	54.0	23.34

#### Note:

- \*Pol. H = Horizontal V = Vertical
- \*\*AF + CL + Amp. = Antenna Factor + Cable Loss + Amplifier.
- \*\*\*Distance factor =  $20 \log(\text{test distance}/\text{specific distance}) = 20 \log(1/3)$
- Other spurious are under 20 dB below Fundamental.
- The radiated emissions testing were made by rotating through three orthogonal axes.  
The worst date was recorded.
- At frequencies above 1 GHz, peak emissions were measured using RBW = 1 MHz, VBW = 3 MHz,  
Detector = Peak.
- As the EUT was configured to transmit with duty cycles  $\geq 98$  percent, at frequencies above 1 GHz, average  
emission levels were measured using the "Method VB" by setting the analyzer RBW = 1 MHz, VBW = 300  
Hz (VBW  $\leq$  RBW/100), Detector = Peak.
- The spectrum is measured from 9 kHz to 10<sup>th</sup> harmonic and the worst-case emissions are reported.  
No significant emissions were found beyond the third harmonic for this device.
- The peak limit of non-restricted band is -27 dBm/MHz can be converted 68.2 dB $\mu$ V/m per KDB789033.
- For non-restricted band, the peak limit is 68.2 dB $\mu$ V/m.
- For restricted band, the peak limit is 74 dB $\mu$ V/m and the average limit is 54 dB $\mu$ V/m per § 15.209.

# TEST DATA

## 8.7.2 Radiated Spurious Emissions – Band II

FCC §15.407(b), RSS-210 Issue 8, A9.2

Test Mode : Set to Lowest channel, Middle channel and Highest channel

### 802.11a mode

#### Chain 0

##### Lowest Channel (5260 MHz)

Frequency (GHz)	Reading (dBμV)	Pol* (H/V)	mode	AF+CL+Amp (dB)**	Distance (dB)***	Result (dBμV/m)	Limit (dBμV/m)	Margin (dB)
10.52	57.32	V	peak	2.62	-9.54	50.40	68.2	17.80
15.78	58.44	H	peak	2.53	-9.54	51.43	74.0	22.57
15.78	41.79	H	average	2.53	-9.54	34.78	54.0	19.22

##### Middle Channel (5280 MHz)

Frequency (GHz)	Reading (dBμV)	Pol* (H/V)	mode	AF+CL+Amp (dB)**	Distance (dB)***	Result (dBμV/m)	Limit (dBμV/m)	Margin (dB)
10.56	59.37	V	peak	3.13	-9.54	52.96	68.2	15.24
15.84	58.79	H	peak	2.80	-9.54	52.05	74.0	21.95
15.84	42.30	H	average	2.80	-9.54	35.56	54.0	18.44

##### Highest Channel (5320 MHz)

Frequency (GHz)	Reading (dBμV)	Pol* (H/V)	mode	AF+CL+Amp (dB)**	Distance (dB)***	Result (dBμV/m)	Limit (dBμV/m)	Margin (dB)
10.64	59.24	V	peak	3.46	-9.54	53.16	74.0	20.84
10.64	44.20	V	average	3.46	-9.54	38.12	54.0	15.88
15.96	58.94	H	peak	1.13	-9.54	50.53	74.0	23.47
15.96	42.64	H	average	1.13	-9.54	34.23	54.0	19.77

# TEST DATA

## 802.11a mode

### Chain 1

#### Lowest Channel (5260 MHz)

Frequency (GHz)	Reading (dB $\mu$ V)	Pol* (H/V)	mode	AF+CL+Amp (dB)**	Distance (dB)***	Result (dB $\mu$ V/m)	Limit (dB $\mu$ V/m)	Margin (dB)
10.52	52.98	V	peak	2.62	-9.54	46.06	68.2	22.14
15.78	54.72	H	peak	2.53	-9.54	47.71	74.0	26.29
15.78	39.07	H	average	2.53	-9.54	32.06	54.0	21.94

#### Middle Channel (5280 MHz)

Frequency (GHz)	Reading (dB $\mu$ V)	Pol* (H/V)	mode	AF+CL+Amp (dB)**	Distance (dB)***	Result (dB $\mu$ V/m)	Limit (dB $\mu$ V/m)	Margin (dB)
10.56	51.81	V	peak	3.13	-9.54	45.40	68.2	22.80
15.84	54.51	H	peak	2.80	-9.54	47.77	74.0	26.23
15.84	39.03	H	average	2.80	-9.54	32.29	54.0	21.71

#### Highest Channel (5320 MHz)

Frequency (GHz)	Reading (dB $\mu$ V)	Pol* (H/V)	mode	AF+CL+Amp (dB)**	Distance (dB)***	Result (dB $\mu$ V/m)	Limit (dB $\mu$ V/m)	Margin (dB)
10.64	49.31	V	peak	3.46	-9.54	43.23	74.0	30.77
10.64	34.82	H	average	3.46	-9.54	28.74	54.0	25.26
15.96	56.91	H	peak	1.13	-9.54	48.50	74.0	25.50
15.96	40.49	H	average	1.13	-9.54	32.08	54.0	21.92

# TEST DATA

## 802.11n(20 MHz) mode

### Chain 0 + Chain 1

#### Lowest Channel (5260 MHz)

Frequency (GHz)	Reading (dB $\mu$ V)	Pol* (H/V)	mode	AF+CL+Amp (dB)**	Distance (dB)***	Result (dB $\mu$ V/m)	Limit (dB $\mu$ V/m)	Margin (dB)
10.52	50.62	V	peak	2.62	-9.54	43.70	68.2	24.50
15.78	52.80	H	peak	2.53	-9.54	45.79	74.0	28.21
15.78	38.55	H	average	2.53	-9.54	31.54	54.0	22.46

#### Middle Channel (5280 MHz)

Frequency (GHz)	Reading (dB $\mu$ V)	Pol* (H/V)	mode	AF+CL+Amp (dB)**	Distance (dB)***	Result (dB $\mu$ V/m)	Limit (dB $\mu$ V/m)	Margin (dB)
10.56	51.87	V	peak	3.13	-9.54	45.46	68.2	22.74
15.84	53.31	H	peak	2.80	-9.54	46.57	74.0	27.43
15.84	38.40	H	average	2.80	-9.54	31.66	54.0	22.34

#### Highest Channel (5320 MHz)

Frequency (GHz)	Reading (dB $\mu$ V)	Pol* (H/V)	mode	AF+CL+Amp (dB)**	Distance (dB)***	Result (dB $\mu$ V/m)	Limit (dB $\mu$ V/m)	Margin (dB)
10.64	51.07	H	peak	3.46	-9.54	44.99	74.0	29.01
10.64	36.47	H	average	3.46	-9.54	30.39	54.0	23.61
15.96	53.70	H	peak	1.13	-9.54	45.29	74.0	28.71
15.96	38.50	H	average	1.13	-9.54	30.09	54.0	23.91

# TEST DATA

## 802.11n(40 MHz) mode

### Chain 0 + Chain 1

#### Lowest Channel (5270 MHz)

Frequency (GHz)	Reading (dB $\mu$ V)	Pol* (H/V)	mode	AF+CL+Amp (dB)**	Distance (dB)***	Result (dB $\mu$ V/m)	Limit (dB $\mu$ V/m)	Margin (dB)
10.54	49.15	V	peak	3.31	-9.54	42.92	68.2	25.28
15.81	52.53	H	peak	2.68	-9.54	45.67	74.0	28.33
15.81	38.42	H	average	2.63	-9.54	31.51	54.0	22.49

#### Highest Channel (5310 MHz)

Frequency (GHz)	Reading (dB $\mu$ V)	Pol* (H/V)	mode	AF+CL+Amp (dB)**	Distance (dB)***	Result (dB $\mu$ V/m)	Limit (dB $\mu$ V/m)	Margin (dB)
10.62	48.81	H	peak	3.78	-9.54	43.05	74.0	30.95
10.62	35.79	V	average	3.78	-9.54	30.03	54.0	23.97
15.93	52.50	V	peak	1.75	-9.54	44.71	74.0	29.29
15.93	37.92	V	average	1.75	-9.54	30.13	54.0	23.87

#### Note:

- \*Pol. H = Horizontal V = Vertical
- \*\*AF + CL + Amp. = Antenna Factor + Cable Loss + Amplifier.
- \*\*\*Distance factor =  $20 \log(\text{test distance}/\text{specific distance}) = 20 \log(1/3)$
- Other spurious are under 20 dB below Fundamental.
- The radiated emissions testing were made by rotating through three orthogonal axes.  
The worst date was recorded.
- At frequencies above 1 GHz, peak emissions were measured using RBW = 1 MHz, VBW = 3 MHz,  
Detector = Peak.
- As the EUT was configured to transmit with duty cycles  $\geq 98$  percent, at frequencies above 1 GHz, average  
emission levels were measured using the "Method VB" by setting the analyzer RBW = 1 MHz, VBW = 300  
Hz (VBW  $\leq$  RBW/100), Detector = Peak.
- The spectrum is measured from 9 kHz to 10<sup>th</sup> harmonic and the worst-case emissions are reported.  
No significant emissions were found beyond the third harmonic for this device.
- The peak limit of non-restricted band is -27 dBm/MHz can be converted 68.2 dB $\mu$ V/m per KDB789033.
- For non-restricted band, the peak limit is 68.2 dB $\mu$ V/m.
- For restricted band, the peak limit is 74 dB $\mu$ V/m and the average limit is 54 dB $\mu$ V/m per § 15.209.

# TEST DATA

## 8.7.3 Radiated Spurious Emissions – Band III

FCC §15.407(b), RSS-210 Issue 8, A9.2

Test Mode : Set to Lowest channel, Middle channel and Highest channel

### 802.11a mode

#### Chain 0

##### Lowest Channel (5500 MHz)

Frequency (GHz)	Reading (dBμV)	Pol* (H/V)	mode	AF+CL+Amp (dB)**	Distance (dB)***	Result (dBμV/m)	Limit (dBμV/m)	Margin (dB)
11.00	56.80	V	peak	4.32	-9.54	51.58	74.0	22.42
11.00	42.52	V	average	4.32	-9.54	37.30	54.0	16.70
16.50	58.57	V	peak	2.90	-9.54	51.93	68.2	16.27

##### Middle Channel (5580 MHz)

Frequency (GHz)	Reading (dBμV)	Pol* (H/V)	mode	AF+CL+Amp (dB)**	Distance (dB)***	Result (dBμV/m)	Limit (dBμV/m)	Margin (dB)
11.16	56.71	V	peak	3.04	-9.54	50.21	74.0	23.79
11.16	40.55	V	average	3.04	-9.54	34.05	54.0	19.95
16.74	60.65	V	peak	3.75	-9.54	54.86	68.2	13.34

##### Highest Channel (5700 MHz)

Frequency (GHz)	Reading (dBμV)	Pol* (H/V)	mode	AF+CL+Amp (dB)**	Distance (dB)***	Result (dBμV/m)	Limit (dBμV/m)	Margin (dB)
11.40	64.91	V	peak	2.89	-9.54	58.26	74.0	15.74
11.40	47.12	V	average	2.89	-9.54	40.47	54.0	13.53
17.10	58.92	V	peak	4.24	-9.54	53.62	68.2	14.58

# TEST DATA

## 802.11a mode

### Chain 1

#### Lowest Channel (5500 MHz)

Frequency (GHz)	Reading (dB $\mu$ V)	Pol* (H/V)	mode	AF+CL+Amp (dB)**	Distance (dB)***	Result (dB $\mu$ V/m)	Limit (dB $\mu$ V/m)	Margin (dB)
11.00	52.45	V	peak	4.32	-9.54	47.23	74.0	26.77
11.00	37.32	V	average	4.32	-9.54	32.10	54.0	21.90
16.50	65.39	H	peak	2.90	-9.54	58.75	68.2	9.45

#### Middle Channel (5580 MHz)

Frequency (GHz)	Reading (dB $\mu$ V)	Pol* (H/V)	mode	AF+CL+Amp (dB)**	Distance (dB)***	Result (dB $\mu$ V/m)	Limit (dB $\mu$ V/m)	Margin (dB)
11.16	52.73	V	peak	3.04	-9.54	46.23	74.0	27.77
11.16	38.97	V	average	3.04	-9.54	32.47	54.0	21.53
16.74	65.75	H	peak	3.75	-9.54	59.96	68.2	8.24

#### Highest Channel (5700 MHz)

Frequency (GHz)	Reading (dB $\mu$ V)	Pol* (H/V)	mode	AF+CL+Amp (dB)**	Distance (dB)***	Result (dB $\mu$ V/m)	Limit (dB $\mu$ V/m)	Margin (dB)
11.40	55.10	V	peak	2.89	-9.54	48.45	74.0	25.55
11.40	39.33	V	average	2.89	-9.54	32.68	54.0	21.32
17.10	63.18	H	peak	4.24	-9.54	57.88	68.2	10.32



# TEST DATA

## 802.11n(20 MHz) mode

### Chain 0 + Chain 1

#### Lowest Channel (5500 MHz)

Frequency (GHz)	Reading (dBμV)	Pol* (H/V)	mode	AF+CL+Amp (dB)**	Distance (dB)***	Result (dBμV/m)	Limit (dBμV/m)	Margin (dB)
11.00	50.61	V	peak	4.32	-9.54	45.39	74.0	28.61
11.00	37.44	V	average	4.32	-9.54	32.22	54.0	21.78
16.50	56.63	H	peak	2.90	-9.54	49.99	68.2	18.21

#### Middle Channel (5580 MHz)

Frequency (GHz)	Reading (dBμV)	Pol* (H/V)	mode	AF+CL+Amp (dB)**	Distance (dB)***	Result (dBμV/m)	Limit (dBμV/m)	Margin (dB)
11.16	51.27	V	peak	3.04	-9.54	44.77	74.0	29.23
11.16	36.08	H	average	3.04	-9.54	29.58	54.0	24.42
16.74	57.33	H	peak	3.75	-9.54	51.54	68.2	16.66

#### Highest Channel (5700 MHz)

Frequency (GHz)	Reading (dBμV)	Pol* (H/V)	mode	AF+CL+Amp (dB)**	Distance (dB)***	Result (dBμV/m)	Limit (dBμV/m)	Margin (dB)
11.40	57.33	V	peak	2.89	-9.54	50.68	74.0	23.32
11.40	42.03	V	average	2.89	-9.54	35.38	54.0	18.62
17.10	56.91	H	peak	4.24	-9.54	51.61	68.2	16.59

# TEST DATA

## 802.11n(40 MHz) mode

### Chain 0 + Chain 1

#### Lowest Channel (5510 MHz)

Frequency (GHz)	Reading (dB $\mu$ V)	Pol* (H/V)	mode	AF+CL+Amp (dB)**	Distance (dB)***	Result (dB $\mu$ V/m)	Limit (dB $\mu$ V/m)	Margin (dB)
11.02	48.27	V	peak	4.55	-9.54	43.28	74.0	30.72
11.02	34.42	H	average	4.55	-9.54	29.43	54.0	24.57
16.53	54.28	H	peak	3.19	-9.54	47.93	68.2	20.27

#### Middle Channel (5590 MHz)

Frequency (GHz)	Reading (dB $\mu$ V)	Pol* (H/V)	mode	AF+CL+Amp (dB)**	Distance (dB)***	Result (dB $\mu$ V/m)	Limit (dB $\mu$ V/m)	Margin (dB)
11.18	49.74	H	peak	3.05	-9.54	43.25	74.0	30.75
11.18	36.08	V	average	3.05	-9.54	29.59	54.0	24.41
16.77	53.63	H	peak	3.90	-9.54	47.99	68.2	20.21

#### Highest Channel (5670 MHz)

Frequency (GHz)	Reading (dB $\mu$ V)	Pol* (H/V)	mode	AF+CL+Amp (dB)**	Distance (dB)***	Result (dB $\mu$ V/m)	Limit (dB $\mu$ V/m)	Margin (dB)
11.34	51.45	V	peak	2.91	-9.54	44.82	74.0	29.18
11.34	38.05	V	average	2.91	-9.54	31.42	54.0	22.58
17.01	55.33	H	peak	4.62	-9.54	50.41	68.2	17.79

#### **Note:**

- \*Pol. H = Horizontal V = Vertical
- \*\*AF + CL + Amp. = Antenna Factor + Cable Loss + Amplifier.
- \*\*\*Distance factor =  $20 \log (\text{test distance}/\text{specific distance}) = 20 \log (1 / 3)$
- Other spurious are under 20 dB below Fundamental.
- The radiated emissions testing were made by rotating through three orthogonal axes.  
The worst date was recorded.

6. At frequencies above 1 GHz, peak emissions were measured using  $RBW = 1 \text{ MHz}$ ,  $VBW = 3 \text{ MHz}$ ,  
Detector = Peak.
7. As the EUT was configured to transmit with duty cycles  $\geq 98$  percent, at frequencies above 1 GHz, average  
emission levels were measured using the "Method VB" by setting the analyzer  $RBW = 1 \text{ MHz}$ ,  $VBW = 300$   
Hz ( $VBW \leq RBW/100$ ), Detector = Peak.
8. The spectrum is measured from 9 kHz to  $10^{\text{th}}$  harmonic and the worst-case emissions are reported.  
No significant emissions were found beyond the third harmonic for this device.
9. The peak limit of non-restricted band is  $-27 \text{ dBm/MHz}$  can be converted  $68.2 \text{ dB}\mu\text{V/m}$  per KDB789033.
10. For non-restricted band, the peak limit is  $68.2 \text{ dB}\mu\text{V/m}$ .
11. For restricted band, the peak limit is  $74 \text{ dB}\mu\text{V/m}$  and the average limit is  $54 \text{ dB}\mu\text{V/m}$  per § 15.209.

# TEST DATA

## 8.8 Radiated Band Edge

### 8.8.1 Radiated Band Edge – Band I and II

#### FCC §15.407(b), RSS-210 Issue 8, A9.2

**Test Mode : Set to Lowest channel, Middle channel and Highest channel**

#### 802.11a mode

#### Chain 0

##### Lowest Channel (5180 MHz)

Frequency (MHz)	Reading (dBμV)	Pol* (H/V)	mode	AF+CL+Amp (dB)**	Result (dBμV/m)	Limit (dBμV/m)	Margin (dB)
5148.35	52.10	V	peak	9.60	61.70	74.0	12.30
5148.35	38.20	V	average	9.60	47.80	54.0	6.20

##### Highest Channel (5320 MHz)

Frequency (MHz)	Reading (dBμV)	Pol* (H/V)	mode	AF+CL+Amp (dB)**	Result (dBμV/m)	Limit (dBμV/m)	Margin (dB)
5350.22	55.50	V	peak	9.80	65.30	74.0	8.70
5350.22	37.70	V	average	9.80	47.50	54.0	6.50

#### Chain 1

##### Lowest Channel (5180 MHz)

Frequency (MHz)	Reading (dBμV)	Pol* (H/V)	mode	AF+CL+Amp (dB)**	Result (dBμV/m)	Limit (dBμV/m)	Margin (dB)
5147.85	52.00	H	peak	9.60	61.60	74.0	12.40
5147.85	36.50	H	average	9.60	46.10	54.0	7.90

##### Highest Channel (5320 MHz)

Frequency (MHz)	Reading (dBμV)	Pol* (H/V)	mode	AF+CL+Amp (dB)**	Result (dBμV/m)	Limit (dBμV/m)	Margin (dB)
5350.41	44.70	V	peak	9.80	54.50	74.0	19.50
5350.41	35.10	V	average	9.80	44.90	54.0	9.10

# TEST DATA

## 802.11n(20 MHz) mode

### Chain 0 + Chain 1

#### Lowest Channel (5180 MHz)

Frequency (MHz)	Reading (dB $\mu$ V)	Pol* (H/V)	mode	AF+CL+Amp (dB)**	Result (dB $\mu$ V/m)	Limit (dB $\mu$ V/m)	Margin (dB)
5149.92	42.90	H	peak	9.60	52.50	74.0	21.50
5149.92	33.50	H	average	9.60	43.10	54.0	10.90

#### Highest Channel (5320 MHz)

Frequency (MHz)	Reading (dB $\mu$ V)	Pol* (H/V)	mode	AF+CL+Amp (dB)**	Result (dB $\mu$ V/m)	Limit (dB $\mu$ V/m)	Margin (dB)
5351.93	46.00	V	peak	9.80	55.80	74.0	18.20
5351.93	34.80	V	average	9.80	44.60	54.0	9.40

## 802.11n(40 MHz) mode

### Chain 0 + Chain 1

#### Lowest Channel (5190 MHz)

Frequency (MHz)	Reading (dB $\mu$ V)	Pol* (H/V)	mode	AF+CL+Amp (dB)**	Result (dB $\mu$ V/m)	Limit (dB $\mu$ V/m)	Margin (dB)
5149.27	58.80	H	peak	9.60	68.40	74.0	5.60
5149.27	41.00	H	average	9.60	50.60	54.0	3.40

#### Highest Channel (5310 MHz)

Frequency (MHz)	Reading (dB $\mu$ V)	Pol* (H/V)	mode	AF+CL+Amp (dB)**	Result (dB $\mu$ V/m)	Limit (dB $\mu$ V/m)	Margin (dB)
5351.14	49.50	H	peak	9.80	59.30	74.0	14.70
5351.14	36.70	H	average	9.80	46.50	54.0	7.50

**Note:**

1. \*Pol. H = Horizontal V = Vertical
2. \*\*AF + CL + Amp. = Antenna Factor + Cable Loss + Amplifier.
3. The radiated emissions testing were made by rotating through three orthogonal axes.  
The worst date was recorded.
4. At frequencies above 1 GHz, peak emissions were measured using RBW = 1 MHz, VBW = 3 MHz, Detector = Peak.
5. As the EUT was configured to transmit with duty cycles  $\geq 98$  percent, at frequencies above 1 GHz, average emission levels were measured using the "Method VB" by setting the analyzer RBW = 1 MHz, VBW = 300 Hz ( $VBW \leq RBW/100$ ), Detector = Peak.
6. For non-restricted band, the peak limit is 68.2 dB $\mu$ V/m.
7. For restricted band, the peak limit is 74 dB $\mu$ V/m and the average limit is 54 dB $\mu$ V/m per § 15.209.

# TEST DATA

## 8.8.2 Radiated Band Edge – Band III

### FCC §15.407(b), RSS-210 Issue 8, A9.2

Test Mode : Set to Lowest channel, Middle channel and Highest channel

### 802.11a mode

#### Chain 0

##### Lowest Channel (5500 MHz)

Frequency (MHz)	Reading (dBμV)	Pol* (H/V)	mode	AF+CL+Amp (dB)**	Result (dBμV/m)	Limit (dBμV/m)	Margin (dB)
5459.66	47.90	V	peak	10.20	58.10	74.0	15.90
5459.66	35.10	V	average	10.20	45.30	54.0	8.70
5469.34	54.40	V	peak	10.20	64.60	68.2	3.60

##### Highest Channel (5700 MHz)

Frequency (MHz)	Reading (dBμV)	Pol* (H/V)	mode	AF+CL+Amp (dB)**	Result (dBμV/m)	Limit (dBμV/m)	Margin (dB)
5725.56	52.00	V	peak	10.40	62.40	68.2	5.80

#### Chain 1

##### Lowest Channel (5500 MHz)

Frequency (MHz)	Reading (dBμV)	Pol* (H/V)	mode	AF+CL+Amp (dB)**	Result (dBμV/m)	Limit (dBμV/m)	Margin (dB)
5459.96	45.45	H	peak	10.20	55.65	74.0	18.35
5459.96	34.60	H	average	10.20	44.80	54.0	9.20
5469.20	56.80	H	peak	10.20	67.00	68.2	1.20

##### Highest Channel (5700 MHz)

Frequency (MHz)	Reading (dBμV)	Pol* (H/V)	mode	AF+CL+Amp (dB)**	Result (dBμV/m)	Limit (dBμV/m)	Margin (dB)
5725.82	56.50	H	peak	10.40	66.90	68.2	1.30

# TEST DATA

## 802.11n(20 MHz) mode

### Chain 0 + Chain 1

#### Lowest Channel (5500 MHz)

Frequency (MHz)	Reading (dBμV)	Pol* (H/V)	mode	AF+CL+Amp (dB)**	Result (dBμV/m)	Limit (dBμV/m)	Margin (dB)
5459.97	44.08	H	peak	10.20	54.28	74.0	19.72
5459.97	34.90	H	average	10.20	45.10	54.0	8.90
5469.37	47.50	H	peak	10.20	57.70	68.2	10.50

#### Highest Channel (5700 MHz)

Frequency (MHz)	Reading (dBμV)	Pol* (H/V)	mode	AF+CL+Amp (dB)**	Result (dBμV/m)	Limit (dBμV/m)	Margin (dB)
5725.64	54.10	H	peak	10.40	64.50	68.2	3.70

## 802.11n(40 MHz) mode

### Chain 0 + Chain 1

#### Lowest Channel (5510 MHz)

Frequency (MHz)	Reading (dBμV)	Pol* (H/V)	mode	AF+CL+Amp (dB)**	Result (dBμV/m)	Limit (dBμV/m)	Margin (dB)
5459.95	47.52	V	peak	10.20	57.72	74.0	16.28
5459.95	35.40	V	average	10.20	45.60	54.0	8.40
5469.97	55.20	V	peak	10.20	65.40	68.2	2.80

#### Highest Channel (5670 MHz)

Frequency (MHz)	Reading (dBμV)	Pol* (H/V)	mode	AF+CL+Amp (dB)**	Result (dBμV/m)	Limit (dBμV/m)	Margin (dB)
5725.78	47.70	V	peak	10.40	58.10	68.2	10.10



**Note:**

1. \*Pol. H = Horizontal V = Vertical
2. \*\*AF + CL + Amp. = Antenna Factor + Cable Loss + Amplifier.
3. The radiated emissions testing were made by rotating through three orthogonal axes.  
The worst date was recorded.
4. At frequencies above 1 GHz, peak emissions were measured using RBW = 1 MHz, VBW = 3 MHz,  
Detector = Peak.
5. As the EUT was configured to transmit with duty cycles  $\geq 98$  percent, at frequencies above 1 GHz, average  
emission levels were measured using the "Method VB" by setting the analyzer RBW = 1 MHz, VBW = 300  
Hz ( $VBW \leq RBW/100$ ), Detector = Peak.
6. For non-restricted band, the peak limit is 68.2 dB $\mu$ V/m.
7. For restricted band, the peak limit is 74 dB $\mu$ V/m and the average limit is 54 dB $\mu$ V/m per § 15.209.

# TEST DATA

## 8.8 Frequency Stability

### 8.8.1 Frequency Stability – Band I

FCC §15.407(g), RSS-210 Issue 8, A9.4

Test channel : Middle channel (5200 MHz)

Standard test voltage : 5 Vdc

#### Measurement Result :

Voltage (%)	Power (Vdc)	Temp. (°C)	Frequency (Hz)	Frequency Error (Hz)	ppm
100 %	5.00	+ 23(Ref.)	5200011483	11483	2.2083
100 %		- 30	5199984867	-15133	-2.9102
100 %		- 20	5200007742	7742	1.4888
100 %		- 10	5200020685	20685	3.9779
100 %		0	5200023966	23966	4.6088
100 %		10	5200017890	17890	3.4404
100 %		20	5200010676	10676	2.0531
100 %		30	5199998951	-1049	-0.2017
100 %		40	5199992832	-7168	-1.3785
100 %		50	5199988394	-11606	-2.2319
85 %	4.25	23	5200011223	11223	2.1583
115 %	5.75	23	5200011261	11261	2.1656

**Note:**

The temperature is varied from –30 °C to +50 °C using an environmental chamber.

## TEST DATA

### 8.8.2 Frequency Stability – Band II

#### FCC §15.407(g), RSS-210 Issue 8, A9.4

Test channel : Middle channel (5280 MHz)

Standard test voltage : 5 Vdc

#### Measurement Result :

Voltage (%)	Power (Vdc)	Temp. (°C)	Frequency (Hz)	Frequency Error (Hz)	ppm
100 %	5.00	+ 23(Ref.)	5280002521	2521	0.4775
100 %		- 30	5279987394	-12606	-2.3875
100 %		- 20	5280008254	8254	1.5633
100 %		- 10	5280020679	20679	3.9165
100 %		0	5280023873	23873	4.5214
100 %		10	5280018230	18230	3.4527
100 %		20	5280012206	12206	2.3117
100 %		30	5279998958	-1042	-0.1973
100 %		40	5279992056	-7944	-1.5045
100 %		50	5279987829	-12171	-2.3051
85 %	4.25	23	5280003672	3672	0.6955
115 %	5.75	23	5280001868	1868	0.3538

**Note:**

The temperature is varied from –30 °C to +50 °C using an environmental chamber.

## TEST DATA

### 8.8.3 Frequency Stability – Band III

#### FCC §15.407(g), RSS-210 Issue 8, A9.4

Test channel : Middle channel (5580 MHz)

Standard test voltage : 5 Vdc

#### Measurement Result :

Voltage (%)	Power (Vdc)	Temp. (°C)	Frequency (Hz)	Frequency Error (Hz)	ppm
100 %	5.00	+ 23(Ref.)	5580000593	593	0.1063
100 %		- 30	5579985070	-14930	-2.6756
100 %		- 20	5580009531	9531	1.7081
100 %		- 10	5580021655	21655	3.8808
100 %		0	5580025125	25125	4.5027
100 %		10	5580019503	19503	3.4952
100 %		20	5580015352	15352	2.7513
100 %		30	5579998948	-1052	-0.1885
100 %		40	5579991113	-8887	-1.5927
100 %		50	5579987472	-12528	-2.2452
85 %	4.25	23	5580000417	417	0.0747
115 %	5.75	23	5580000856	856	0.1534

**Note:**

The temperature is varied from –30 °C to +50 °C using an environmental chamber.

## 9. TEST EQUIPMENT

No.	Instrument	Manufacturer	Model	Serial No.	Calibration Date	Calibration Interval
1	*Test Receiver	R & S	ESCS 30	833364/020	Jan. 12 2012	1 year
2	*Test Receiver	R & S	ESCS 30	100302	Oct. 08 2012	1 year
3	*Amplifier	HP	8447F	2805A03427	Jul. 17 2012	1 year
4	*Amplifier	Sonoma Instrument	310N	291916	Jul. 16 2012	1 year
5	*Amplifier	R & S	SCU18	10065	Apr. 05 2012	1 year
6	*Amplifier	R & S	SCU26	10011	Jun. 01 2012	1 year
7	*Amplifier	R & S	SCU40	10008	Jun. 01 2012	1 year
8	*Pre Amplifier	HP	8449B	3008A00107	Jan. 13 2012	1 year
9	*Pre Amplifier	HP	8447F	2805A03351	Jul. 17 2012	1 year
10	*Spectrum Analyzer	Agilent	E4440A	MY44303257	Jul. 16 2012	1 year
11	*Spectrum Analyzer	Agilent	E4440A	MY44022567	Apr. 05 2012	1 year
12	*Spectrum Analyzer	R & S	FSP40	100361	Jul. 17 2012	1 year
13	*Loop Antenna	R & S	HFH2-Z2	100279	Feb. 21 2012	2 year
14	Wideband Power Sensor	R & S	NRP-Z81	100634	Apr. 05 2012	1 year
15	*Biconical Log Antenna	ARA	LPB-2520/A	1180	Apr. 26 2012	2 year
16	*Horn Antenna	SCHWARZBECK	BBHA9120D	9120D-474	Aug. 13 2012	2 year
17	*Horn Antenna	Q-par Angus	QSH20S20	8179	Mar. 28 2011	2 year
18	*Horn Antenna	Q-par Angus	QSH22K20	8180	Mar. 28 2011	2 year
19	*Trilog-Broadband Antenna	SCHWARZBECK	VULB 9163	9163-454	Feb. 24 2012	2 year
20	Trilog-Broadband Antenna	SCHWARZBECK	VULB 9168	9168-257	Apr. 26 2012	2 year
21	*LISN	R & S	ESH3-Z5	833874/006	Oct. 08 2012	1 year
22	*LISN	R & S	ESH2-Z5	100227	Apr. 04 2012	1 year
23	*Position Controller	DAEIL EMC	N/A	N/A	N/A	N/A
24	*Turn Table	DAEIL EMC	N/A	N/A	N/A	N/A
25	*Antenna Mast	DAEIL EMC	N/A	N/A	N/A	N/A
26	*Anechoic Chamber	EM Eng.	N/A	N/A	N/A	N/A
27	*Shielded Room	EM Eng.	N/A	N/A	N/A	N/A
28	*Position Controller	Seo-Young EMC	N/A	N/A	N/A	N/A
29	*Turn Table	Seo-Young EMC	N/A	N/A	N/A	N/A
30	*Antenna Mast	Seo-Young EMC	N/A	N/A	N/A	N/A
31	*Anechoic Chamber	Seo-Young EMC	N/A	N/A	N/A	N/A
32	*Shielded Room	Seo-Young EMC	N/A	N/A	N/A	N/A

\*) Test equipment used during the test

## 10. ACCURACY OF MEASUREMENT

The Measurement Uncertainties stated were calculated in accordance with the requirements of measurement uncertainty contained in CISPR 16-4-2 with the confidence level of 95%

### 1. Conducted Uncertainty Calculation

Source of Uncertainty	$X_i$	Uncertainty of $X_i$		Coverage factor $k$	$u(X_i)$ (dB)	$C_i$	$C_i u(X_i)$ (dB)
		Value (dB)	Probability Distribution				
Receiver reading	<b>RI</b>	± 0.1	normal 1	1.000	0.1	1	0.1
Attenuation AMN-Receiver	<b>LC</b>	± 0.08	normal 2	2.000	0.04	1	0.04
AMN Voltage division factor	<b>LAMN</b>	± 0.8	normal 2	2.000	0.4	1	0.4
Sine wave voltage	<b>dVSW</b>	± 2.00	normal 2	2.000	1.00	1	1.00
Pulse amplitude response	<b>dVPA</b>	± 1.50	rectangular	1.732	0.87	1	0.87
Pulse repetition rate response	<b>dVPR</b>	± 1.50	rectangular	1.732	0.87	1	0.87
Noise floor proximity	<b>dVNF</b>	± 0.00	-	-	0.00	1	0.00
AMN Impedance	<b>dZ</b>	± 1.80	triangular	2.449	0.73	1	0.73
Ⓐ Mismatch	<b>M</b>	+ 0.70	U-Shaped	1.414	0.49	1	0.49
Ⓑ Mismatch	<b>M</b>	- 0.80	U-Shaped	1.414	- 0.56	1	- 0.56
Measurement System Repeatability	<b>RS</b>	0.05	normal 1	1.000	0.05	1	0.05
Remark	Ⓐ: AMN-Receiver Mismatch : + Ⓑ: AMN-Receiver Mismatch : -						
Combined Standard Uncertainty	Normal			± 1.88			
Expended Uncertainty U	Normal ( $k = 2$ )			± 3.76			

## 2. Radiation Uncertainty Calculation

Source of Uncertainty	$X_i$	Uncertainty of $X_i$		Coverage factor $k$	$u(X_i)$ (dB)	$C_i$	$C_i u(X_i)$ (dB)
		Value (dB)	Probability Distribution				
Receiver reading	<b>RI</b>	± 0.10	normal 1	1.000	0.10	1	0.10
Sine wave voltage	<b>dVsw</b>	± 2.00	normal 2	2.000	1.00	1	1.00
Pulse amplitude response	<b>dVpa</b>	± 1.50	rectangular	1.732	0.87	1	0.87
Pulse repetition rate response	<b>dVpr</b>	± 1.50	rectangular	1.732	0.87	1	0.87
Noise floor proximity	<b>dVnf</b>	± 0.50	normal 2	2.000	0.25	1	0.25
Antenna Factor Calibration	<b>AF</b>	± 1.50	normal 2	2.000	0.75	1	0.75
Attenuation Antenna-receiver	<b>CL</b>	± 0.52	normal 2	2.000	0.26	1	0.26
Antenna Directivity	<b>AD</b>	± 1.00	rectangular	1.732	0.58	1	0.58
Antenna Factor Height Dependence	<b>AH</b>	± 0.50	rectangular	1.732	0.29	1	0.29
Antenna Phase Centre Variation	<b>AP</b>	± 0.30	rectangular	1.732	0.17	1	0.17
Antenna Factor Frequency Interpolation	<b>AI</b>	± 0.30	rectangular	1.732	0.17	1	0.17
Site Imperfections	<b>SI</b>	± 4.00	triangular	2.449	1.63	1	1.63
Measurement Distance Variation	<b>DV</b>	± 0.10	rectangular	1.732	0.06	1	0.06
Antenna Balance	<b>Dbal</b>	± 0.90	rectangular	1.732	0.52	1	0.52
Cross Polarisation	<b>DCross</b>	± 0.90	rectangular	1.732	0.52	1	0.52
Ⓐ Mismatch	<b>M</b>	+ 0.25	U-Shaped	1.414	0.18	1	0.18
Ⓑ Mismatch	<b>M</b>	- 0.26	U-Shaped	1.414	- 0.18	1	- 0.18
Ⓒ Mismatch	<b>M</b>	+ 0.98	U-Shaped	1.414	0.69	1	0.69
Ⓓ Mismatch	<b>M</b>	- 1.11	U-Shaped	1.414	- 0.79	1	- 0.79
Measurement System Repeatability	<b>RS</b>	0.09	normal 1	1.000	0.09	1	0.09
Remark	Ⓐ: Biconical Antenna-receiver Mismatch : + (< 200 MHz) Ⓑ: Biconical Antenna-receiver Mismatch : - (< 200 MHz) Ⓒ: Log Periodic Antenna-receiver Mismatch : + (≥ 200 MHz) Ⓓ: Log Periodic Antenna-receiver Mismatch : - (≥ 200 MHz)						
Combined Standard Uncertainty	Normal			± 2.63 (< 200 MHz) ± 2.74 (≥ 200 MHz)			
Expanded Uncertainty U	Normal (k = 2)			± 5.26 (< 200 MHz) ± 5.48 (≥ 200 MHz)			