

# CHEMTRONICS

## Motion Detection Sensor Module User Manual

<b>Product Name</b>	<b>Motion Detection Sensor Module</b>
<b>Model Name</b>	<b>MDRAI302</b>
<b>Version</b>	<b>0.1</b>
<b>Date</b>	<b>October 09, 2020</b>

## Revision History

<b>Version</b>	<b>Date</b>	<b>Description</b>
0.1	October 09, 2020	Draft Version

# Contents

<b>1. Overview</b> .....	4
<b>2. System Specification</b> .....	5
2.1 Physical feature.....	5
2.2 Pin Description.....	6
2.3 Module Specification.....	7
2.4 RF Specification .....	9
<b>3. Module Assembly</b> .....	10

# 1. Overview

This product is a module developed for effective human or object recognition using the built-in RADAR sensor. Built-in detectors that allow full autonomous operation of the device. Detector Designed to operate as a Doppler motion sensor from 61 to 61.5 GHz (60.5 to 61 GHz for the Japanese ISM band).

The compact 2-in-1 (RGB color sensor + IR receiver) is a transparent epoxy transfer mold package on the lead frame. The IR module provides excellent performance even in disturbing ambient light applications and provides protection against uncontrolled output pulses. RGB color sensor is an advanced digital ambient light sensor that converts luminosity into a digital signal output. The RGB color sensor for ambient light detection has 5 open photodiodes (red, green, blue, transparent, IR).

The microphone mounted on top of the product is a compact low power bottom port silicone microphone with a single bit PDM output. This device has great performance and is suitable for applications such as music recorders and other suitable electronic devices.

The color sensor detects red, green, blue and white. Sensitivity to human eye reactions. Offers excellent temperature compensation. The actual function of the color sensor is a simple command format of I2C interface protocol.

The accelerometer is a process micromachine accelerometer that has already been used in production in rugged and mature manufacturing belonging to the "femto" family of ultra-low-power, high-performance 3-axis linear accelerometers.

There is an integrated 32-level pre-conceived, FIFO (first-in, first-out) buffer with data for users to limit host intervention Processor.

## Features

- 60GHz Radar IC with one transmitter and one receiver unit
- Antennas in Package (AiP) Radar IC
- CW and pulsed-CW mode of operation
- Integrated PLL for Doppler and FMCW ramp generation
- Color(R,G,B,W) Sensor with I2C Interface
- 2-in-1 ALI(RGB color sensor + IR receiver)
- D-MIC(SPH0655LM4H-1)
- Micro-machine accelerometer belonging to the "femto" family.
- 38.4MHz X-Tal

## Applications

- Smart TV appliances

**The Motion Detection Sensor Module specified is a product that is installed in the application after being mounted on the frame in actual use.**

## 2. System Specification

### 2.1 Physical feature

Item	Specification
Product Name	Motion Detection Sensor Module
Model Name	MDRAI302
Communication method	61.251 GHz (ISM BAND) RADAR (DOPPLER)
Dimension	35.00mm x 27.00mm x 1.4mm(T)
Weight	2.67g
Mounting Type	FFC Connector(14Pin Header), Screw(1Hole)
Function	Acceleration Sensor, MIC, 2-in-1 ALI, Color Sensor
Mutual of the person being certified	CHEMTRONICS Co., Ltd
Manufacturer/country of manufacture	CHEMTRONICS Co., Ltd / Korea
Date of manufacture	Marked separately
Certification Number	-

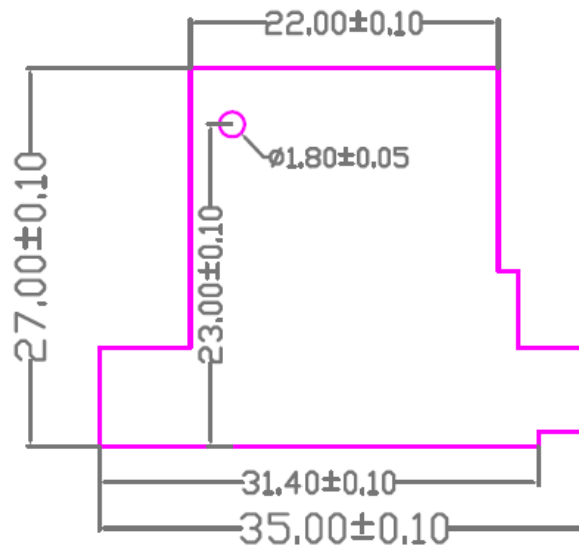

## 2.2 Pin Description

Pin No.	Pin Name	Type	Function	Pin No.	Pin Name	Type	Function
1	IRRR_1B	I	IR Signal Receive	2	3.3_PW	P	INPUT 3.3V
3	MCU_M_DET_OUT_1B	I/O	Detection Signal Read	4	R_SCL1_TV_1B	I/O	MCU_I2C_SCL
5	R_SDA1_TV_1B	I/O	MCU_I2C_SDA	6	MIC_SWITCH_1B	I/O	MIC_ Power Control
7	R_SCL2_TV	I/O	Sensor_I2C_SCL	8	R_SDA2_TV	I/O	Sensor_I2C_SDA
9	MCU_RESET_1B	O	MCU_RESET	10	R_MIC_DATA_1B	I/O	MIC_I2C_SDA
11	R_MIC_CLK_1B	I/O	MIC_I2C_CLK	12	GND	P	Digital Ground
13	R_LED_STB_OUT_1B	P	RED LED Control	14	KEY_INPUT_R_1B	I	TACT KEY INPUT

## 2.3 Module Specification

### 2.3.1 Product Summary

Item	P/N	Description
<b>Radar IC</b>	BGT60LTR11AiP	- Low Power 60GHz Doppler Radar Sensor
<b>MCU</b>	XMC1302-Q024X006	- 8 kbytes on-chip ROM - 16 kbytes on-chip high-speed SRAM - up to 200 kbytes on-chip Flash program and data memory
<b>LDO</b>	LP590715QDQNRQ1	- Automotive 250-mA - Ultra-Low-Noise, Low-IQ LDO
<b>X-TAL</b>	X.ME. 112HJVF0038400000	- XME-SMD2520 - 38.400000MHz - 12 PF/60ohms
<b>FET</b>	2N7002K	- Small Signal MOSFET - 60 V, 380 mA, Single, N-Channel, SOT-23
<b>LEVEL SHIFTER</b>	SN74AVC4T245RSVR	- Dual-Bit Bus Transceiver with Configurable Voltage Translation and 3-State Outputs
<b>MIC</b>	SPH0655LM4H-1	- Low Distortion / High AOP - Low Current Consumption in Low-Power Mode - Flat Frequency Response
<b>ACCELERATION SENSOR</b>	LIS2DWLTR	- Very low noise: down to 1.3 mg RMS in low power Mode - supply voltage, 1.62 V to 3.6 V - High-speed I2C/SPI digital output interface
<b>2-in-1 ALI</b>	J315XRHH-R	- Supply Voltage : IR Receiver(6.0V), RGB color Sensor(3.6V) - Supply Current : IR Receiver(1.0mA), RGB color Sensor(20mA) - Internal filter for a high frequency lighting fluorescent lamp - Automatic light flickering cancellation supporting
<b>Color Sensor</b>	RCS-D6C6CV-R	-i2c interface -Detect R,G,B,W colors
<b>SLIDE S/W</b>	JS6901EM	- This specification is applied to low current circuit slide switch for electronic equipment.
<b>TACT S/W</b>	DHT-1187AC	-

### 2.3.2 Electrical Specification

Parameter	Description	Min.	Typ.	Max.	Units
Supply Voltage		3.0	-	5.5	V
Operating Current	RMS	-	-	65	mA

### 2.3.3 Environment Specification

Item	Specification
Storage Temperature	-25°C to + 115°C
Operating Temperature	-10°C to + 80°C
Humidity (Operational)	85%(50°C) relative humidity
Vibration (Operational)	5 Hz to 500 Hz sinusoidal, 1.0G
Drop	No damages after 75cm drop over concrete floor
ESD [Electrostatic discharge]	+/- 0.8 kV Human Body Model (JESD22-A114-B)



## 2.4 RF Specification

### 2.4.1 System Characteristics

Parameter	Condition	Min.	Typ.	Max.	Units
<b>Transmitted Frequency (EU ISM BAND)</b>	Vtune = VCPOUTPLL		61.251		GHz
<b>Spurious Emission &lt; 40GHz</b>				-42	dBm
<b>Spurious Emission &gt; 40GHz and &lt; 57GHz</b>				-20	dBm
<b>Spurious Emission &gt; 68GHz and &lt; 78GHz</b>				-20	dBm
<b>Spurious Emission &gt; 78GHz</b>				-30	dBm

### 2.4.2 Antenna Characteristics

Parameter	Test Condition	Min.	Typ.	Max.	Units
<b>Operating Frequency Range</b>			61.251		GHz
<b>Transmitter Antenna Gain</b>	@ Freq = 61.25GHz		6.761		dB
<b>Receiver Antenna Gain</b>	@ Freq = 61.25GHz		6.761		dB
<b>Horizontal -3Db Beamwidth</b>	@ Freq = 61.25GHz		80		Deg
<b>Vertical -3dB Beamwidth</b>	@ Freq = 61.25GHz		80		Deg
<b>Horizontal sidelobe suppression</b>	@ Freq = 61.25GHz		12		dB
<b>Vertical sidelobe suppression</b>	@ Freq = 61.25GHz		12		dB
<b>TX-RX Isolation</b>	@ Freq = 61.25GHz		35		dB

### 3. Module Assembly

Be careful not to damage the module when you assemble or disassemble. If you press heavily RADAR IC, it may affect the overall performance.

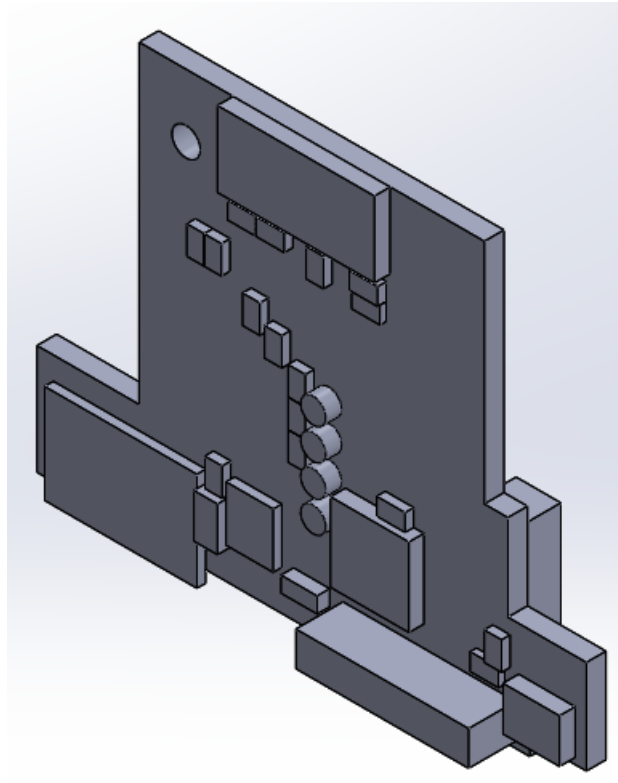

※ Screw: CA+ B D:2.5 H:0.5 C:0.15; 1.7\*2.5\*3 CR+3 WH

## **FCC MODULAR APPROVAL INFORMATION EXAMPLES for Manual**

This device complies with Part 15 of the FCC Rules. Operation is subject to the following two conditions:

- (1) This device may not cause harmful interference.
- (2) This device must accept any interference received, including interference that may cause undesired operation.

**CAUTION:** Changes or modifications not expressly approved by the party responsible for compliance could void the user's authority to operate the equipment.

NOTE: This equipment has been tested and found to comply with the limits for a Class B digital device, pursuant to Part 15 of the FCC Rules. These limits are designed to provide reasonable protection against harmful interference in a residential installation. This equipment generates uses and can radiate radio frequency energy and, if not installed and used in accordance with the instructions, may cause harmful interference to radio communications. However, there is no guarantee that interference will not occur in a particular installation. If this equipment does cause harmful interference to radio or television reception, which can be determined by turning the equipment off and on, the user is encouraged to try to correct the interference by one or more of the following measures:

- Reorient or relocate the receiving antenna.
- Increase the separation between the equipment and receiver.
- Connect the equipment into an outlet on a circuit different from that to which the receiver is connected.
- Consult the dealer or an experienced radio/TV technician for help.

### **FCC Radiation Exposure Statement:**

This equipment complies with FCC radiation exposure limits set forth for an uncontrolled environment. This equipment should be installed and operated with minimum distance 20cm between the radiator & your body.

**OEM INTEGRATION INSTRUCTIONS:**

This device is intended only for OEM integrators under the following conditions:

The module must be installed in the host equipment such that 20 cm is maintained between the antenna and users, and the transmitter module may not be co-located with any other transmitter or antenna. The module shall be only used with the internal on-board antenna that has been originally tested and certified with this module. External antennas are not supported. As long as these 3 conditions above are met, further transmitter test will not be required.

However, the OEM integrator is still responsible for testing their end-product for any additional compliance requirements required with this module installed (for example, digital device emissions, PC peripheral requirements, etc.). The end-product may need Verification testing, Declaration of Conformity testing, a Permissive Class II Change or new Certification. Please involve a FCC certification specialist in order to determine what will be exactly applicable for the end-product.

**Validity of using the module certification:**

In the event that these conditions cannot be met (for example certain laptop configurations or co-location with another transmitter), then the FCC authorization for this module in combination with the host equipment is no longer considered valid and the FCC ID of the module cannot be used on the final product. In these circumstances, the OEM integrator will be responsible for re-evaluating the end product (including the transmitter) and obtaining a separate FCC authorization. In such cases, please involve a FCC certification specialist in order to determine if a Permissive Class II Change or new Certification is required.

**Upgrade Firmware:**

The software provided for firmware upgrade will not be capable to affect any RF parameters as certified for the FCC for this module, in order to prevent compliance issues.

**End product labeling:**

This transmitter module is authorized only for use in device where the antenna may be installed such that 20 cm may be maintained between the antenna and users. The final end product must be labeled in a visible area with the following: "Contains FCC ID: A3LMDRAI302".

**Information that must be placed in the end user manual:**

The OEM integrator has to be aware not to provide information to the end user regarding how to install or remove this RF module in the user's manual of the end product which integrates this module. The end user manual shall include all required regulatory information/warning as show in this manual.

## **FCC MODULAR APPROVAL INFORMATION EXAMPLES for Manual**

This device complies with Part 15 of the FCC Rules. Operation is subject to the following two conditions:

- (1) This device may not cause harmful interference.
- (2) This device must accept any interference received, including interference that may cause undesired operation.

**CAUTION:** Changes or modifications not expressly approved by the party responsible for compliance could void the user's authority to operate the equipment.

**NOTE:** This equipment has been tested and found to comply with the limits for a Class B digital device, pursuant to Part 15 of the FCC Rules. These limits are designed to provide reasonable protection against harmful interference in a residential installation. This equipment generates uses and can radiate radio frequency energy and, if not installed and used in accordance with the instructions, may cause harmful interference to radio communications. However, there is no guarantee that interference will not occur in a particular installation. If this equipment does cause harmful interference to radio or television reception, which can be determined by turning the equipment off and on, the user is encouraged to try to correct the interference by one or more of the following measures:

- Reorient or relocate the receiving antenna.
- Increase the separation between the equipment and receiver.
- Connect the equipment into an outlet on a circuit different from that to which the receiver is connected.
- Consult the dealer or an experienced radio/TV technician for help.

## **WARNING**

Changes or modifications not expressly approved by the manufacturer could void the user's authority to operate the equipment.

“CAUTION : Exposure to Radio Frequency Radiation.

Antenna shall be mounted in such a manner to minimize the potential for human contact during normal operation. The antenna should not be contacted during operation to avoid the possibility of exceeding the FCC radio frequency exposure limit.

## IC Information

This device complies with Industry Canada license-exempt RSS standard(s). Operation is subject to the following two conditions:

- (1) this device may not cause interference, and
- (2) this device must accept any interference, including interference that may cause undesired operation of the device.

*Cet appareil est conforme avec Industrie Canada exempts de licence standard RSS (s). L'opération est soumise aux deux conditions suivantes:*

- (1) cet appareil ne peut causer d'interférences, et*
- (2) cet appareil doit accepter toute interférence, y compris les interférences qui peuvent causer un mauvais fonctionnement de l'appareil.*

The end product must be labeled to display the Industry Canada certification number of the module.

Contains transmitter module IC: 649E-MDRAI302

*Le dispositif d'accueil doivent être étiquetés pour afficher le numéro de certification d'Industrie Canada du module.*

*Contient module émetteur IC: 649E-MDRAI302*

## Information for OEM Integrator

This device is intended only for OEM integrators under the following conditions:

- 1) The antenna must be installed such that 20 cm is maintained between the antenna and users, and
- 2) The transmitter module may not be co-located with any other transmitter or antenna.

End product labelling

The label for end product must include

“Contains FCC ID: A3LMDRAI302, Contains IC: 649E-MDRAI302”.

“CAUTION: Exposure to Radio Frequency Radiation.

This equipment complies with FCC radiation exposure limits set forth for an uncontrolled environment. This equipment should be installed and operated with minimum distance of 20cm between the radiator and your body. This transmitter module is authorized only for use in device where the antenna may be installed such that 20 cm may be maintained between the antenna and users.”

## Requirement per KDB996369 D03

### 2.2 List of applicable FCC rules

List the FCC rules that are applicable to the modular transmitter. These are the rules that specifically establish the bands of operation, the power, spurious emissions, and operating fundamental frequencies. DO NOT list compliance to unintentional-radiator rules (Part 15 Subpart B) since that is not a condition of a module grant that is extended to a host manufacturer. See also Section 2.10 below concerning the need to notify host manufacturers that further testing is required.<sup>3</sup>

**Explanation:** This module meets the requirements of FCC part 15C(15.255).

### 2.3 Summarize the specific operational use conditions

Describe use conditions that are applicable to the modular transmitter, including for example any limits on antennas, etc. For example, if point-to-point antennas are used that require reduction in power or compensation for cable loss, then this information must be in the instructions. If the use condition limitations extend to professional users, then instructions must state that this information also extends to the host manufacturer's instruction manual. In addition, certain information may also be needed, such as peak gain per frequency band and minimum gain, specifically for master devices in 5 GHz DFS bands.

**Explanation:** The EUT has a Chip Antenna, and the antenna use a permanently attached antenna which is not replaceable.

### 2.4 Limited module procedures

If a modular transmitter is approved as a "limited module," then the module manufacturer is responsible for approving the host environment that the limited module is used with. The manufacturer of a limited module must describe, both in the filing and in the installation instructions, the alternative means that the limited module manufacturer uses to verify that the host meets the necessary requirements to satisfy the module limiting conditions.

A limited module manufacturer has the flexibility to define its alternative method to address the conditions that limit the initial approval, such as: shielding, minimum signaling amplitude, buffered modulation/data inputs, or power supply regulation. The alternative method could include that the limited module manufacturer reviews detailed test data or host designs prior to giving the host manufacturer approval.

This limited module procedure is also applicable for RF exposure evaluation when it is necessary to demonstrate compliance in a specific host. The module manufacturer must state how control of the product into which the modular transmitter will be installed will be maintained such that full compliance of the product is always ensured. For additional hosts other than the specific host originally granted with a limited module, a Class II permissive change is required on the module grant to register the additional host as a specific host also approved with the module.



**Explanation:** Clear and specific instructions describing the conditions, limitations and procedures for third-parties to use and/or integrate the module into a host device (see Comprehensive integration instructions below).

Resolve:

Installation Notes:

- 1) Supply example as follows: The host product should supply the regulated power of 1.5 V, 3.0 ~ 5.5 V DC to module.
- 2) Make sure the module pins correctly installed.
- 3) Make sure that the module does not allow users to replace or demolition
- 4) The Module specified is a product that is installed in the application after being mounted on the frame in actual use.  
The Frame a shielding part to cover the module.

## 2.5 Trace antenna designs

For a modular transmitter with trace antenna designs, see the guidance in Question 11 of KDB Publication 996369 D02 FAQ – Modules for Micro-Strip Antennas and traces. The integration information shall include for the TCB review the integration instructions for the following aspects:

layout of trace design, parts list (BOM), antenna, connectors, and isolation requirements.

- a) Information that includes permitted variances (e.g., trace boundary limits, thickness, length, width, shape(s), dielectric constant, and impedance as applicable for each type of antenna);
- b) Each design shall be considered a different type (e.g., antenna length in multiple(s) of frequency, the wavelength, and antenna shape (traces in phase) can affect antenna gain and must be considered);
- c) The parameters shall be provided in a manner permitting host manufacturers to design the printed circuit (PC) board layout;
- d) Appropriate parts by manufacturer and specifications;
- e) Test procedures for design verification; and
- f) Production test procedures for ensuring compliance.

The module grantee shall provide a notice that any deviation(s) from the defined parameters of the antenna trace, as described by the instructions, require that the host product manufacturer must notify the module grantee that they wish to change the antenna trace design. In this case, a Class II permissive change application is required to be filed by the grantee, or the host manufacturer can take responsibility through the change in FCC ID (new application) procedure followed by a Class II permissive change application.

**Explanation:** Yes, The module with trace antenna designs, and This manual has been shown the layout of trace design, antenna, connectors, and isolation requirements.

## 2.6 RF exposure considerations

It is essential for module grantees to clearly and explicitly state the RF exposure conditions that permit a host product manufacturer to use the module. Two types of instructions are required for RF exposure information: (1) to the host product manufacturer, to define the application conditions (mobile, portable – xx cm from a person's body); and (2) additional text needed for the host product manufacturer to provide to end users in their end-product manuals. If RF exposure statements and use conditions are not provided, then the host product manufacturer is required to take responsibility of the module through a change in FCC ID (new application).

**Explanation:** This module complies with FCC RF radiation exposure limits set forth for an uncontrolled environment, This equipment should be installed and operated with a minimum distance of 20 centimeters between the radiator and your body." This module is designed to comply with the FCC statement, FCC ID is: A3LMDRAI302.

## 2.7 Antennas

A list of antennas included in the application for certification must be provided in the instructions. For modular transmitters approved as limited modules, all applicable professional installer instructions must be included as part of the information to the host product manufacturer. The antenna list shall also identify the antenna types (monopole, PIFA, dipole, etc. (note that for example an “omni-directional antenna” is not considered to be a specific “antenna type”)).

For situations where the host product manufacturer is responsible for an external connector, for example with an RF pin and antenna trace design, the integration instructions shall inform the installer that unique antenna connector must be used on the Part 15 authorized transmitters used in the host product. The module manufacturers shall provide a list of acceptable unique connectors.

**Explanation:** The EUT has a Chip Antenna, and the antenna use a permanently attached antenna which is unique.

## 2.8 Label and compliance information

Grantees are responsible for the continued compliance of their modules to the FCC rules. This includes advising host product manufacturers that they need to provide a physical or e-label stating “Contains FCC ID” with their finished product. See Guidelines for Labeling and User Information for RF Devices – KDB Publication 784748.

**Explanation:**The host system using this module, should have label in a visible area indicated the following texts: “Contains FCC ID: A3LMDRAI302, Contains IC: 649E-MDRAI302”

## 2.9 Information on test modes and additional testing requirements

Additional guidance for testing host products is given in KDB Publication 996369 D04 Module Integration Guide. Test modes should take into consideration different operational conditions for a stand-alone modular transmitter in a host, as well as for multiple simultaneously transmitting modules or other transmitters in a host product.

The grantee should provide information on how to configure test modes for host product evaluation for different operational conditions for a stand-alone modular transmitter in a host, versus with multiple, simultaneously transmitting modules or other transmitters in a host.

Grantees can increase the utility of their modular transmitters by providing special means, modes, or instructions that simulates or characterizes a connection by enabling a transmitter. This can greatly simplify a host manufacturer’s determination that a module as installed in a host complies with FCC requirements.

**Explanation:** Top band can increase the utility of our modular transmitters by providing instructions that simulates or characterizes a connection by enabling a transmitter.

### **2.10 Additional testing, Part 15 Subpart B disclaimer**

The grantee should include a statement that the modular transmitter is only FCC authorized for the specific rule parts (i.e., FCC transmitter rules) listed on the grant, and that the host product manufacturer is responsible for compliance to any other FCC rules that apply to the host not covered by the modular transmitter grant of certification. If the grantee markets their product as being Part 15 Subpart B compliant (when it also contains unintentional-radiator digital circuitry), then the grantee shall provide a notice stating that the final host product still requires Part 15 Subpart B compliance testing with the modular transmitter installed.

**Explanation:** The module without unintentional-radiator digital circuitry, so the module does not require an evaluation by FCC Part 15 Subpart B. The host should be evaluated by the FCC Subpart B.