

# EMC TEST REPORT

## Samsung Electronics Co., Ltd.

416 Maetan 3-Dong, Yeongtong-Gu, Suwon-Si, Gyeonggi-Do, 443-742 Korea  
(Tel: 031 277 7752, Fax: 031 277 7753)  
NVLAP Code : 200623-0



### 1. Applicant

- Name of organization : Samsung Electronics Co., Ltd.
- Address : 416 Maetan 3-Dong, Yeongtong-Gu, Suwon-Si, Gyeonggi-Do, 443-742 Korea

2. Purpose for the report : Approval for EMC

3. Kind of product : Multi Function Printer (Model name: CLX-3160FN)

4. Date of test : 2006.06.11 ~ 2006.06.20

5. Applied standard : FCC Part 15, Subpart B

6. Report No. : LBE061722 Issue 1

7. FCC ID : A3LIR31CFF

8. Test result : Complied

The equipment under test has found to be compliant with the applied standards.  
(Refer to the attached test result for more detail.)

Tested by

Name : Seung Beom, Choi

Reviewed by

Name : No Cheon, Park

This report is the test result about the sphere accredited by KOLAS which signed the Mutual Recognition Arrangement of International Laboratory Accreditation Cooperation.

2006.06.22

**Samsung Electronics Co., Ltd.**  
**Chief of CS Management Center**

# TEST RESULT

**Test Report No.** : LBE061722

**Applicant / Address** : Samsung Electronics Co., Ltd.  
416 Maetan 3-Dong, Yeongtong-Gu, Suwon-Si, Gyeonggi-Do  
443-742 Korea

**Manufacture / Address** :  
1) Samsung Electronics Co., Ltd.  
259, Gongdan-Dong, Gumi-City, Gyeongsangbuk-Do,  
730-030 Korea  
2) Shandong Samsung Telecommunications Co., Ltd.  
264209, Samsugn (Sanxing) Road, Weihai Hi-Tech.  
IDZ, Shandong Province, P.R.China

**EUT** :  
1. Product name : Multi Function Printer  
2. Model name : CLX-3160FN  
3. Brand name : Samsung, Xerox  
4. Variant model : CLX-3160N  
Phaser 6110MFP/XN  
Phaser 6110MFP/SN

**Test Method** : ANSI C 63.4:2003

**Test Result** : **Complied**  
The equipment under test has found to be compliant  
with the applied standards

**Test Lab.** : CS Management Center, Samsung Electronics Co., Ltd.  

**Tested by** : Seung Beom, Choi

**Reviewed by** : No Cheon, Park

**Date of Issue** : 2006.06.22

## Table of contents

### **1. General information**

- 1.1 Basic information related product
- 1.2 Detail information related product
- 1.3 Operating mode and condition
- 1.4 Equipment modifications
- 1.5 Test procedure
- 1.6 Test configuration
- 1.7 Applied standard
- 1.8 Test facility

### **2. Summary of test results**

### **3. Description of individual tests**

- 3.1 Conducted emission
- 3.2 Radiated emission

### **4. Appendix A**

- 4.1 Test Photography
- 4.2 EUT Photography

# 1. General information

## 1.1 Basic information related product

Applicant	Samsung Electronics Co., Ltd.
Model name	CLX-3160FN
Applicant address	416 Maetan 3-Dong, Yeongtong-Gu, Suwon-Si, Gyeonggi-Do 443-742 Korea
Contact person	Sang Soo, Noh
Kind of product	Printer
Valiant model	CLX-3160N Phaser 6110MFP/XN Phaser 6110MFP/SN
Manufacturer	1) Samsung Electronics Co., Ltd. 259, Gongdan-Dong, Gumi-City, Gyeongsangbuk-Do, 730-030 Korea 2) Shandong Samsung Telecommunications Co., Ltd. 264209, Samsugn (Sanxing) Road, Weihai Hi-Tech. IDZ, Shandong Province, P.R.China
Rated power	AC 110 V, 60 Hz
New / Alternative / Permissive change information	1. Main board change : V1.1 -> V1.3 2. SMPS board change : V0.93-> V1.0 3. LIU board change : V1.0 -> V1.1 4. Addition of new models

## 1.2 Detail Information related product

### 1.2.1 Specification

Item	Specification
<b>Paper out capacity</b>	Output tray : 100 sheet (face down)
<b>Power Rating</b>	110 ~ 127 VAC, 5A, 50/60 Hz
<b>Power Consumption</b>	Average : 400 W Power Save mode : Less than 17 W
<b>Noise Level</b>	Printing mode Black and white : Less than 49 dBA Color : Less than 48 dBA Copying mode : Less than 55 dBA Standby mode : Less than 35 dBA
<b>Consumable life</b>	Black Toner Cartridge : Approx. 2,000 A4/Letter pages at 5% Coverage Yellow/Magenta/Cyan Toner Cartridge :

	Approx. 1,000 A4/Letter pages at 5% Coverage
<b>Display</b>	16 characters x 2 lines
<b>Memory</b>	128MB
<b>Printing method</b>	Laser Beam Printing
<b>Print Resolution</b>	Up to 2400 x 600 dpi effective output
<b>Printer Language</b>	SPL-C
<b>Scanning method</b>	ADF and Flat-bed Color CCD module
<b>Resolution</b>	Optical : 600 x 1200 dpi (mono and color) Enhanced : 4,800 x 4,800 dpi
<b>Copy speed</b>	Black & White : Up to 14 cpm in A4 or Letter Color : Up to 4 cpm in A4 or Letter
<b>Copy resolution</b>	Scan : up to 600 x 300 dpi(text, text/photo) up to 600 x 600 dpi(photo) Print : up to 600 x 600 dpi(text, text/photo) up to 1200 x 1200 dpi(photo)
<b>Modem speed</b>	33.6 kbps
<b>Transmission speed</b>	Approx. 3 second/page
<b>Maximum document length</b>	Scanner glass : 11.7 inches ADF : 14 inches
<b>Resolution</b>	Standard : 203 x 98 dpi Fine : 203 x 196 dpi Super Fine : 300 x 300 dpi Photo : 203 x 196 dpi Color : 200 x 200 dpi

### 1.3 Operating mode and condition

The system was configured for testing in typical fashion use. Cables were attached to each of the available I/O Ports. Where applicable, peripherals were attached to the I/O cables.

The mode of operation utilized for testing was selected to best simulate typical EUT use.

This EUT has the following operating mode(s).

- Color copy mode

### 1.4 Equipment modifications

No equipment modification

## 1.5 Test procedure

### 1.5.1 Conducted emission

The EUT was placed on a platform nominal size, 1 m by 1.5 m, raised 80 cm above the conducting Ground plane. The rear of tabletop was located 40 cm to the vertical conducting ground plane.

The rear of EUT, including peripherals was aligned and flush with rear of tabletop.

All other surfaces of tabletop was at least 80 cm from any other grounded conducting surface.

I/O cables and AC cables that were connected to the peripherals were bundled in center.

They were folded back and forth forming a bindle 30 cm to 40 cm long and were handed at a 40 cm height to the ground plane.

Each EUT current-carrying power lead, except the ground(safety) lead, were individually connected through a LISN to the input power source.

All unused 50 ohm connectors of the LISN were resistively terminated in 50 ohm when not connected to the measuring equipment.

Frequency Band [MHz]	Instrument	Detector	Resolution Bandwidth	Video Bandwidth
0.15 to 30	EMI Receiver	Quasi-Peak	9 kHz	-
		Average	9 kHz	-

### 1.5.2 Radiated emission

EUT was placed on a platform of nominal size, 1 m by 1.5 m, raised 80 cm above the conducting ground plane. The rear of EUT, including peripherals was aligned and flush with rear of tabletop.

The I/O cables that were connected to the peripherals were bundle in center.

They were folded back and forth forming a bundle 30 cm to 40 cm long and were hanged 40 cm height to the ground plane.

Test was made with the antenna positioned in both the horizontal and vertical planes of polarization.

The measurement antenna was varied in height above the conducting ground plane and the turn table azimuth was varied to obtain the maximum signal strength

The system configuration, clock speed, mode of operation or video resolution, turntable azimuth with respect to the antenna were noted for each frequency found.

The spectrum was scanned from 30 to 1 000 MHz using biconiLog antenna.

The explanation of measuring instrument setup when Respective function is used in any frequency band is as following;

Frequency Band [MHz]	Instrument	Detector	Resolution Bandwidth	Video Bandwidth
30 to 1 000	EMI Receiver	Quasi-Peak	120 kHz	-

## 1.6 Test configuration

### 1.6.1 Used EUT and peripherals

Seq	Device	Model Name	Serial #	Maker	Note
A	Multi Function Printer	CLX-3160FN	-	Samsung, Xerox	EUT
B	Note PC	SENS X15	630B93CY300149J	Samsung	DoC
C	Adapter	API1AD02	CNBA4400162ABJ 6F5375049	Samsung	DoC
D	Mouse	M-UR69	LNA22400077	Samsung	DoC
E	Headset	-	-	Cosy	DoC
F	Phone	SP-F118R	-	Samsung	DoC
G	USB memory	PRO+ 256M	E-D900-03-1996(B)	Memorive	DoC

### 1.6.2 Used cable description

No	Connect Cable	Length [m]	Shielded [Y/N]	Remark
1	Power	1.8	No	EUT
2	Power	1.8	No	Note PC
3	USB	1.5	No	-
4	TEL	2.0	Yes	-
5	TEL (ext)	1.8	No	Phone
6	LAN	1.8	Yes	-

### 1.6.3 Block diagram

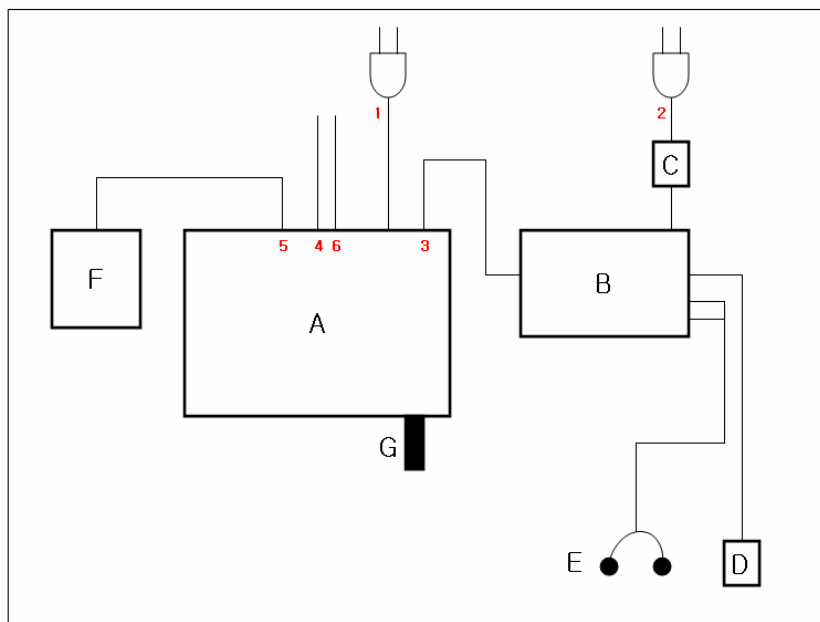

## 1.7 Applied Standards

Test standard	Test method
FCC Part 15, Subpart B, Class B	ANSI C 63.4:2003

### Performance Criteria

- A. normal performance within the specification limits
- B. temporary degradation or less of function or performance which is self-recoverable
- C. temporary degradation or less of function or performance which require operator intervention or system reset

## 1.8 Test Facility

### 1.8.1 General information

The sites are constructed in conformance with the requirements of ANSI C63.4 and CISPR 22, 16-1, 16-2. This EMC Testing Lab. is accredited by Korea Laboratory Accreditation Scheme (KOLAS) which signed the International Laboratory Accreditation Cooperation (ILAC) Mutual Recognition Arrangement (MRA) for the above test item(s) and test method(s).

This Lab. is operated as testing laboratory in accordance with the requirements of ISO/IEC 17025:1998.

### 1.8.2 Accreditation and listing



### 1.8.3 Measurement uncertainty

(According to CISPR 16-4 and Lab. 34)

Test item	Measurement uncertainty
Conducted emission	± 3.3 dB
Radiated emission Horizontal	± 4.0 dB
Vertical	± 4.4 dB

## 2. Summary of test results

**Result : Complied**

**The equipment under test(EUT) has been found to comply with the applied standards.**

Section of the product standard	Applied standard	Test result	
Electromagnetic Emission Test			
3.1	Conducted Emission	FCC Part 15, Subpart B	Complied
3.2	Radiated Emission	FCC Part 15, Subpart B	Complied

### 3. Description of individual tests

#### 3.1 Conducted emission

##### 3.1.1 Test information

Test engineer	Seung Beom, Choi
Test date	June 20, 2006
Climate condition	Ambient temperature : 21.5 , Relative humidity : 34 % Atmospheric pressure 101.3 kPa
Test place	Shielded room # 1

##### 3.1.2 Test equipment

Equipment	Model Name	Manufacturer	Serial No.	Calibration	
				Next Date	Interval
Field strength meter	ESCI	R&S	100086	2007-03-28	12
L.I.S.N	ENV216	R&S	100116	2006-09-08	12
L.I.S.N	ENV216	R&S	100117	2006-08-18	12

#### EUT Test Setup

The EUT was set up as per normal use on a wooden table, 0.4 m from a vertical ground reference plane, At least 0.8 m from other conduction surfaces and 0.8 m from the LISN.

See photo.

#### Test Result

<b>Measurement Results</b>	<b>Complied</b> The measured emissions of the EUT have found to be below the specified limits.
----------------------------	---

**Test Data**

Operating Mode : color copy

**[Graph and Data]**

**Test Information**

EUT Name: CLX-3160FN  
 Serial Number:  
 Test Description: 110V, 60Hz  
 Operating Conditions: Color copy  
 Operator Name: SB, Choi  
 Comment:

**Hardware Setup: Voltage with 2-Line-LISN - [EMI conducted]**

Subrange 1  
 Frequency Range: 150kHz - 30MHz  
 Receiver: ESCI 3  
 Transducer: ENV216 / Receiver-2-Line-LISN ENV216

**Scan Setup: FCC Part 15 Class B\_2-Line-LISN fin [EMI conducted]**

Hardware Setup: Voltage with 2-Line-LISN  
 Level Unit: dBµV

Subrange	Detectors	IF Bandwidth	Meas. Time	Receiver
150kHz - 30MHz	QuasiPeak; Average	9kHz	5s	ESCI 3

**FCC Part 15 Class \_B with 2-Line-LISN**

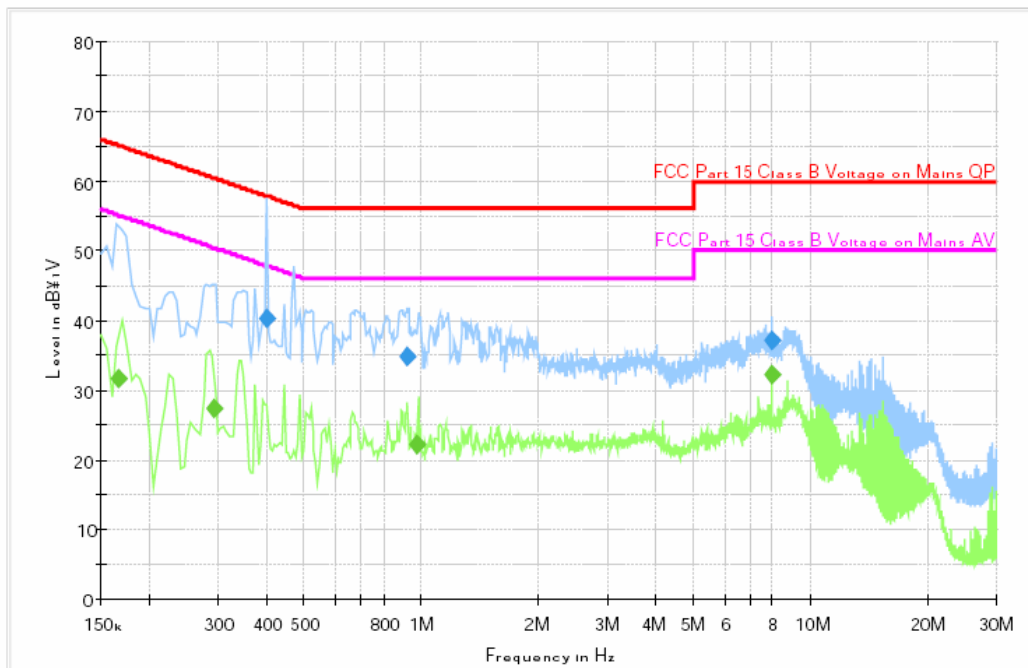

### Final Measurement Detector 1

Frequency (MHz)	QuasiPeak (dBµV)	Meas. Time (ms)	Bandwidth (kHz)	Filter	Line
0.398500	40.3	5000.000	9.000	On	L1
0.922500	34.8	5000.000	9.000	On	N
7.923500	37.1	5000.000	9.000	On	N

(continuation of the "Final Measurement Detector 1" table from column 6 ...)

Frequency (MHz)	Corr. (dB)	Margin (dB)	Limit (dBµV)	Comment
0.398500	9.6	17.6	57.9	
0.922500	9.6	21.2	56.0	
7.923500	9.7	22.9	60.0	

### Final Measurement Detector 2

Frequency (MHz)	Average (dBµV)	Meas. Time (ms)	Bandwidth (kHz)	Filter	Line
0.166500	31.7	5000.000	9.000	On	L1
0.292500	27.3	5000.000	9.000	On	L1
0.973500	22.1	5000.000	9.000	On	L1
7.924500	32.2	5000.000	9.000	On	N

(continuation of the "Final Measurement Detector 2" table from column 6 ...)

Frequency (MHz)	Corr. (dB)	Margin (dB)	Limit (dBµV)	Comment
0.166500	9.6	23.4	55.1	
0.292500	9.6	23.2	50.5	
0.973500	9.6	23.9	46.0	
7.924500	9.7	17.8	50.0	

### 3.2 Radiated emission

#### 3.2.1 Test information

Test engineer	Seung Beom, Choi
Test date	June 12, 2006
Climate condition	Ambient temperature : 22.5 , Relative humidity : 38 % Atmospheric pressure 102.0 kPa
Test place	10 m Semi-Anechoic Chamber # 2

#### 3.2.2 Test equipment

Equipment	Model name	Manufacturer	Serial no.	Calibration	
				Next date	Interval
EMI Test Receiver	ESI-26	R&S	100289	2007-03-13	12
Ant. Mast	MA4000	inn-co	-	N/A	N/A
Ant. Mast	MA4000	inn-co	-	N/A	N/A
Mast Controller	CO2000	inn-co	-	N/A	N/A
Amplifier	310N	SONOMA	251675	2007-03-05	12
RF selector	NS4900	TOYO	-	N/A	N/A
Bi-log Antenna	CBL6141A	SCHAFFNER	4267	2007-05-03	12

#### EUT Test Setup

EUT set up in semi-anechoic chamber. EUT positioned at 10 m from the antenna in the center of the table.

All ports terminated into characteristic loads.

#### Test Result

#### Measurement Results

#### Complied

The measured emissions of the EUT have found to be below the specified limits.

**Test Data (Other Frequency)**

Operating Mode : color copy

**[Graph and Data]**

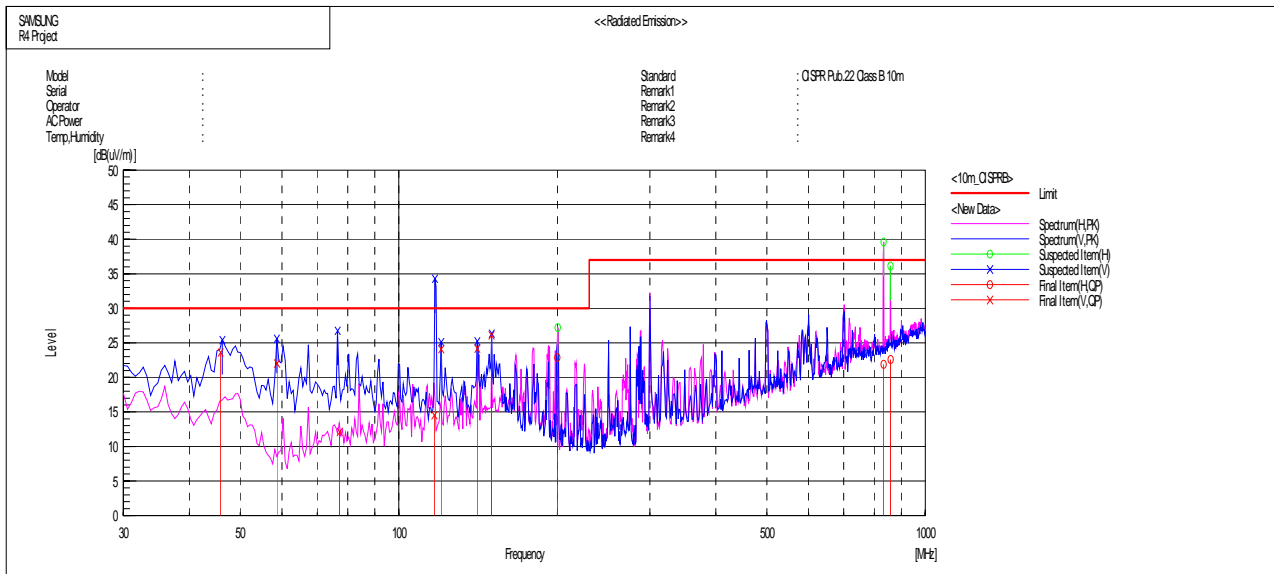

**Final Result**

No.	Frequency (P) [MHz]	Reading QP [dB(uV)]	c.f [dB(1/m)]	Result QP [dB(uV/m)]	Limit [dB(uV/m)]	Margin QP [dB]	Height [cm]	Angle [deg]	Remark
1	116.787	V 32.2	-17.7	14.5	30.0	15.5	112.0	353.7	
2	833.185	H 23.7	-1.8	21.9	37.0	15.1	240.0	305.9	
3	859.292	H 23.3	-0.7	22.6	37.0	14.4	203.0	316.6	
4	199.995	H 40.3	-17.4	22.9	30.0	7.1	338.0	54.8	
5	77.196	V 34.0	-21.9	12.1	30.0	17.9	169.0	104.8	
6	150.009	V 42.8	-16.7	26.1	30.0	3.9	111.0	359.6	
7	58.723	V 42.4	-20.4	22.0	30.0	8.0	362.0	192.0	
8	45.894	V 38.2	-14.6	23.6	30.0	6.4	244.0	18.6	
9	140.922	V 40.9	-16.7	24.2	30.0	5.8	100.0	77.6	
10	120.361	V 41.5	-17.4	24.1	30.0	5.9	400.0	359.6	

- \* Receiving antenna mode : Horizontal, Vertical
- \* Test distance : 10m (RF Semi Anechoic Chamber)
- \* Result = Reading + c.f (Antenna factor + Cable loss- Amp Gain)
- \* Margin = Limit – Result

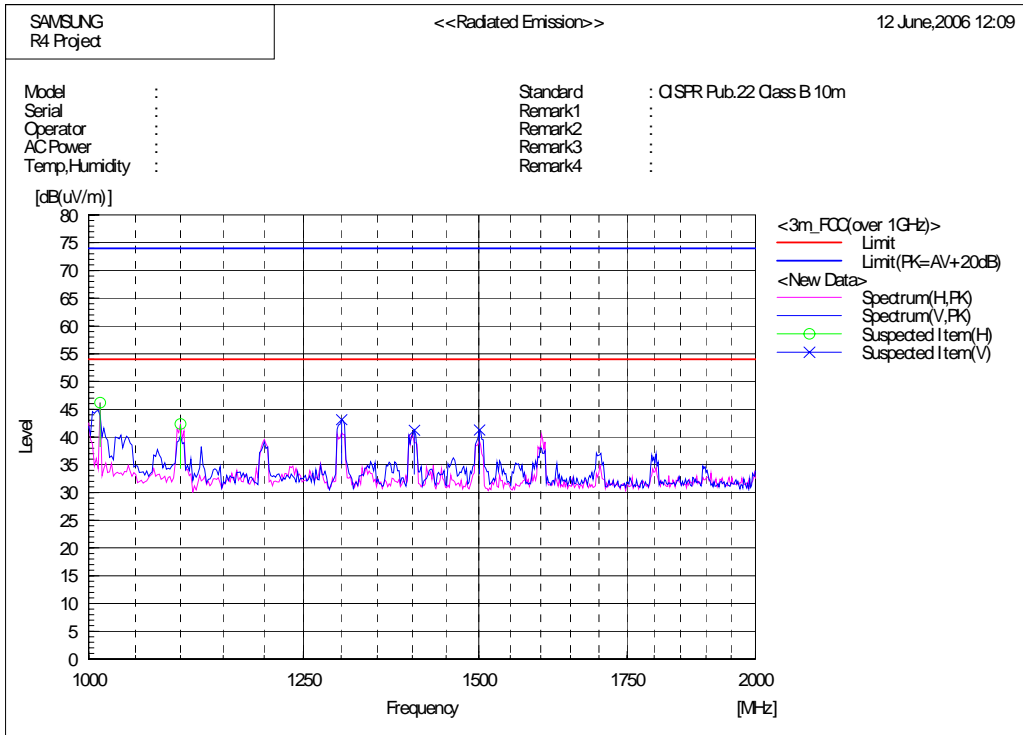

Final Result

No.	Frequency (P)	c.f	Limit	Height	Angle	Remark
	[MHz]	[dB(1/m)]	[dB(uV/m)]	[cm]	[deg]	

- \* Receiving antenna mode : Horizontal, Vertical
- \* Test distance : 3m (RF Semi Anechoic Chamber)
- \* Result = Reading + c.f (Antenna factor + Cable loss- Amp Gain)
- \* Margin = Limit – Result

## 4. Appendix

### 4.1 Test photography



Picture 1. Conducted emission (Front)



Picture 2. Conducted emission (Rear)



Picture 3. Radiated emission (Front)



Picture 4. Radiated emission (Rear)



#### 4.2 EUT photography





Picture 5. EUT (Front)





Picture 6. EUT (Rear)

 <b>USOC Jack Type:RJ11C</b> Samsung Electronics Co., Ltd. Suwon, Korea, 443-742 Place:M259  Serial No.	Model: <b>CLX-3160FN</b> Voltz: <b>AC 110-127V</b> Hertz: <b>50/60Hz</b> Amps: <b>5A</b> Ringer Equivalence: Manufactured:	This device complies with part 15 of the FCC Rules. Operation is subject to the following two conditions: i) This device may not cause harmful interference, and ii) This device must accept any interference received, including interference that may cause undesired operation. FCC ID: A3LIR31CFF Complies with Part 68, FCC Rules. FCC Certification No.: US: A3LFA05BIR31CFF This product complies with 21 CFR Chapter 1, subchapter J. This Class B digital apparatus complies with Canadian ICES-003 Cet appareil numérique de la class B respecte toutes les exigences du Règlement sur le matériel brouilleur du Canada. Cet appareil numérique de la classe "B" est Conforme à la norme NMB-003 du Canada. <b>IC: 649E-IR31CFF</b>
		MADE IN KOREA REV.00

Picture 7. LABEL (CLX-3160FN) - KOREA

 <b>USOC Jack Type:RJ11C</b> Samsung Electronics Co., Ltd. Suwon, Korea, 443-742 Place:M264  Serial No.	Model: <b>CLX-3160FN</b> Voltz: <b>AC 110-127V</b> Hertz: <b>50/60Hz</b> Amps: <b>5A</b> Ringer Equivalence: Manufactured:	This device complies with part 15 of the FCC Rules. Operation is subject to the following two conditions: i) This device may not cause harmful interference, and ii) This device must accept any interference received, including interference that may cause undesired operation. FCC ID: A3LIR31CFF Complies with Part 68, FCC Rules. FCC Certification No.: US: A3LFA05BIR31CFF This product complies with 21 CFR Chapter 1, subchapter J. This Class B digital apparatus complies with Canadian ICES-003 Cet appareil numérique de la class B respecte toutes les exigences du Règlement sur le matériel brouilleur du Canada. Cet appareil numérique de la classe "B" est Conforme à la norme NMB-003 du Canada. <b>IC: 649E-IR31CFF</b>
		MADE IN CHINA REV.00

Picture 8. LABEL (CLX-3160FN) – CHINA

 Samsung Electronics Co., Ltd. Suwon, Korea, 443-742 Place:M259  Serial No.	Model: <b>CLX-3160N</b> Volts: <b>AC 110-127V</b> Hertz: <b>50/60Hz</b> Amps: <b>5A</b> Manufactured:	This device complies with part 15 of the FCC Rules. Operation is subject to the following two conditions: i) This device may not cause harmful interference, and ii) This device must accept any interference received, including interference that may cause undesired operation. FCC ID:A3LIR31CFF This product complies with 21 CFR Chapter 1, subchapter J. This Class B digital apparatus complies with Canadian ICES-003 Cet appareil numérique de la class B respecte toutes les exigences du Règlement sur le matériel brouilleur du Canada. Cet appareil numérique de la classe B est Conforme à la norme NMB-003 du Canada.
		MADE IN KOREA REV.00

Picture 9. LABEL (CLX-3160N) – KOREA

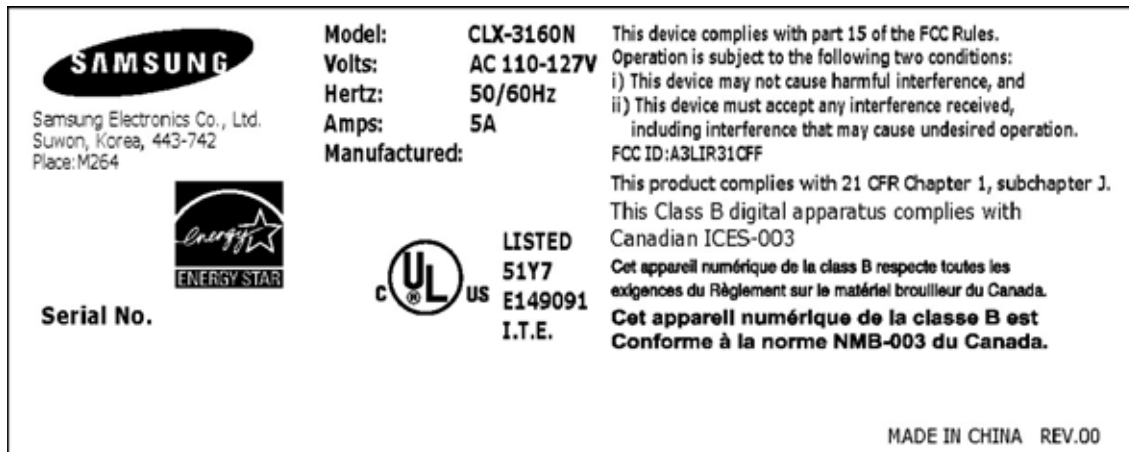

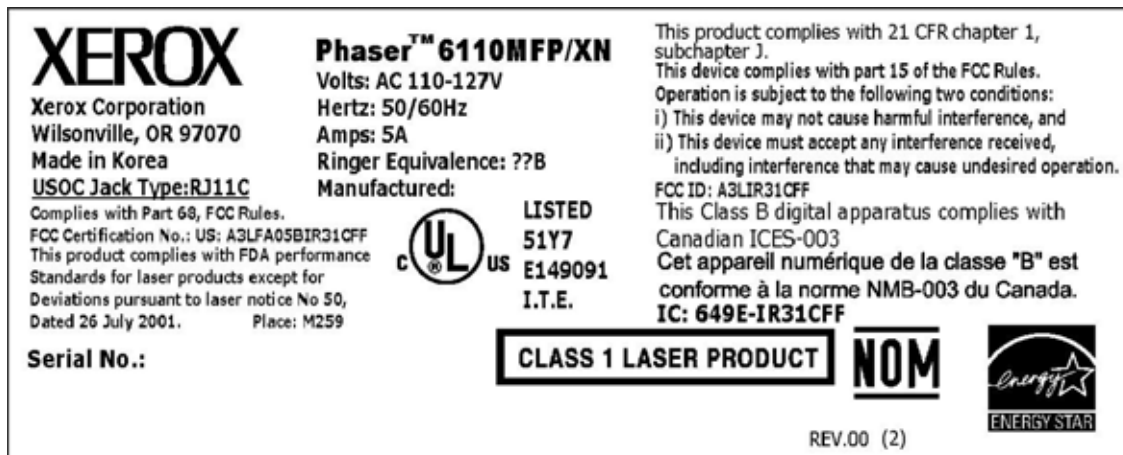

Picture 10. LABEL (CLX-3160N) – CHINA



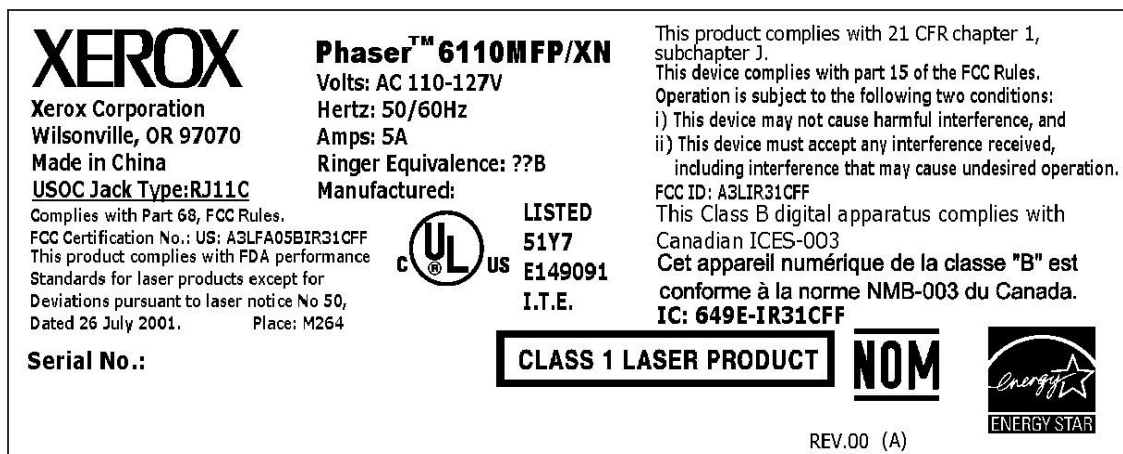

Picture 11. LABEL (Phaser 6110MFP/XN) – KOREA



Picture 12. LABEL (Phaser 6110MFP/XN) – CHINA

<p><b>XEROX</b> Xerox Corporation Wilsonville, OR 97070 Made in Korea USOC Jack Type:RJ11C</p>	<p><b>Phaser™ 6110MFP/SN</b> Volts: AC 110-127V Hertz: 50/60Hz Amps: 5A Manufactured:</p>	<p>This product complies with 21 CFR chapter 1, subchapter J. This device complies with part 15 of the FCC Rules. Operation is subject to the following two conditions: i) This device may not cause harmful interference, and ii) This device must accept any interference received, including interference that may cause undesired operation. FCC ID: A3LIR31CFC This Class B digital apparatus complies with Canadian ICES-003 Cet appareil numérique de la classe "B" est conforme à la norme NMB-003 du Canada.</p>
<p>This product complies with FDA performance Standards for laser products except for Deviations pursuant to laser notice No 50, Dated 26 July 2001. Place: M259</p>		<p>LISTED 51Y7 E149091 I.T.E.</p>
<p>Serial No.:</p>	<p><b>CLASS 1 LASER PRODUCT</b> <b>NOM</b> </p> <p>REV.00 (2)</p>	

Picture 13. LABEL (Phaser 6110MFP/SN) – KOREA

<p><b>XEROX</b> Xerox Corporation Wilsonville, OR 97070 Made in China USOC Jack Type:RJ11C</p>	<p><b>Phaser™ 6110MFP/SN</b> Volts: AC 110-127V Hertz: 50/60Hz Amps: 5A Manufactured:</p>	<p>This product complies with 21 CFR chapter 1, subchapter J. This device complies with part 15 of the FCC Rules. Operation is subject to the following two conditions: i) This device may not cause harmful interference, and ii) This device must accept any interference received, including interference that may cause undesired operation. FCC ID: A3LIR31CFC This Class B digital apparatus complies with Canadian ICES-003 Cet appareil numérique de la classe "B" est conforme à la norme NMB-003 du Canada.</p>
<p>This product complies with FDA performance Standards for laser products except for Deviations pursuant to laser notice No 50, Dated 26 July 2001. Place: M264</p>		<p>LISTED 51Y7 E149091 I.T.E.</p>
<p>Serial No.:</p>	<p><b>CLASS 1 LASER PRODUCT</b> <b>NOM</b> </p> <p>REV.00 (A)</p>	

Picture 14. LABEL (Phaser 6110MFP/SN) – CHINA