

TEST REPORT

FCC Test for HT5H01-60A
Class II Permissive Change

APPLICANT
SAMSUNG Electronics Co., Ltd.

REPORT NO.
HCT-RF-2007-FC009-R2

DATE OF ISSUE
8 July 2020

Tested by
Kwang Il Yoon



Technical Manager
Jong Seok Lee



HCT CO., LTD.

Soo Chan Lee
SooChan Lee / CEO

HCT CO., LTD.

74, Seoicheon-ro 578beon-gil, Majang-myeon, Icheon-si, Gyeonggi-do, 17383 KOREA
Tel. +82 31 634 6300 F ax. +82 31 645 6401



HCT Co., Ltd.

74, Seoicheon-ro 578beon-gil, Majang-myeon, Icheon-si, Gyeonggi-do, 17383 KOREA
Tel. +82 31 634 6300 Fax. +82 31 645 6401

**TEST
REPORT**
FCC Test for
HT5H01-60A

REPORT NO.
HCT-RF-2007-FC009-R2

DATE OF ISSUE
July 08, 2020

Additional Model
-

Applicant	SAMSUNG Electronics Co., Ltd. 129, Samsung-ro, Yeongtong-gu, Suwon-si, Gyeonggi-do, 16677, Rep. of Korea
FCC ID	A3LHT5H01-60A
Product Name	HRU(HT5H01)
Model Name	HT5H01-60A
Date of Test	June 23, 2020 ~ July 08, 2020
Test Standard Used	CFR 47 Part 2, Part 30

The result shown in this test report refer only to the sample(s) tested unless otherwise stated.
This test results were applied only to the test methods required by the standard.

REVISION HISTORY

The revision history for this test report is shown in table.

Revision No.	Date of Issue	Description
0	July 07, 2020	Initial Release
1	July 08, 2020	We added Note on page 10. We added Note at EIRP Density We added Emission Designator and EIRP Density for QPSK.
2	July 08, 2020	Added note justification for how we determined worst-case mode.

The measurements shown in this report were made in accordance with the procedures indicated, and the emissions from this equipment were found to be within the limits applicable. I assume full responsibility for the accuracy and completeness of these measurements, and for the qualifications of all persons taking them. It is further stated that upon the basis of the measurements made, the equipment tested is capable of operation in accordance with the requirements of the FCC Rules under normal use and maintenance.

* The report shall not be reproduced except in full(only partly) without approval of the laboratory.

CONTENTS

1. GENERAL INFORMATION	5
1.1. APPLICANT INFORMATION	5
1.2. PRODUCT INFORMATION	5
1.3. TEST INFORMATION	6
2. FACILITIES AND ACCREDITATIONS	7
2.1. FACILITIES	7
2.2. EQUIPMENT	7
3. TEST SPECIFICATIONS	8
3.1. STANDARDS	8
3.2. ADDITIONAL DESCRIPTIONS ABOUT TEST	9
3.3. MAXIMUM MEASUREMENT UNCERTAINTY	11
3.4. STANDARDS ENVIRONMENTAL TEST CONDITIONS	11
3.5. TEST DIAGRAMS	12
4. TEST EQUIPMENTS	13
5. TEST RESULT	14
5.1. OCCUPIED BANDWIDTH	14
5.2. EIRP DENSITY	23
5.3. CONDUCTED OUTPUT POWER	39
5.4. BAND EDGE	49
5.5. RADIATED SPURIOUS EMISSIONS	61
5.6. FREQUENCY STABILTY	97
6. MIXER VERIFICATION CERTIFICATE & CHECK	100
7. Annex B_EUT AND TEST SETUP PHOTO	115

1. GENERAL INFORMATION

1.1. APPLICANT INFORMATION

Company Name	Samsung Electronics Co., Ltd.
Company Address	129, Samsung-ro, Yeongtong-gu, Suwon-si, Gyeonggi-do, 16677, Rep. of Korea

1.2. PRODUCT INFORMATION

EUT Type	HRU(HT5H01)				
EUT Serial Number	S190726				
Equipment Class	5GB-Part 30 Fixed Transmitter				
Power Supply	AC (100 ~ 240) V				
Output Power (Non-contiguous & Contiguous Mode)	EIRP				
	CC	1 path		Total (2 Path)	
		(dBm)	(W)	(dBm)	(W)
	1	41.00	12.59	44.00	25.12
	2	44.00	25.12	47.00	50.12
	3	45.70	37.15	48.80	75.86
	4	47.00	50.12	50.00	100.00
	5	47.00	50.12	50.00	100.00
	6	47.00	50.12	50.00	100.00
	7	47.00	50.12	50.00	100.00
8	47.00	50.12	50.00	100.00	
	Total (2 Path) MAX: 50 dBm (100 W)				
Frequency Range	37 000 MHz ~ 40 000 MHz				
Emission Designator	Mode	QPSK (G7D)	QPSK Max EIRP Density [W]	16QAM/64QAM (W7D)	QAM Max EIRP Density [W]
	8CC Contiguous	788MG7D	17.906	787MW7D	18.239
	1CC+ 1CC Non-Contiguous	189MG7D	32.961	189MW7D	34.674
Channel Bandwidths	1CC: 100 MHz ~ 8CC: 800 MHz				
Modulation Type	QPSK, 16QAM, 64QAM				

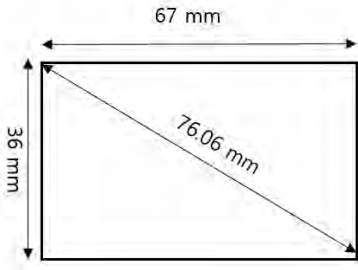
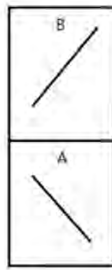
Antenna Specification	<p>Maximum Gain: 25 dBi</p> <p>Size:</p>  <p>Array:</p> 
-----------------------	---

1.3. TEST INFORMATION

FCC Rule Parts	CFR 47 Part 2, Part 30
Measurement standards	ANSI C63.26-2015, KDB 971168 D01 v03r01, KDB 662911 D01 v02r01, KDB 662911 D02 v01, KDB 842590 D01 v01r01
Place of Test	HCT CO., LTD. 74, Seoicheon-ro 578beon-gil, Majang-myeon, Icheon-si, Gyeonggi-do, 17383, Rep. of KOREA

2. FACILITIES AND ACCREDITATIONS

2.1. FACILITIES

The SAC(Semi-Anechoic Chamber) and conducted measurement facility used to collect the radiated data are located at the 74, Seoicheon-ro 578beon-gil, Majang-myeon, Icheon-si, Gyeonggi-do, 17383, Rep. of KOREA. The site is constructed in conformance with the requirements of ANSI C63.4 (Version: 2014) and CISPR Publication 22. Detailed description of test facility was submitted to the Commission and accepted dated April 02, 2018 (Registration Number: KR0032).

2.2. EQUIPMENT

Radiated emissions are measured with one or more of the following types of Linearly polarized antennas: tuned dipole, bi-conical, log periodic, bi-log, and/or ridged waveguide, horn. Spectrum analyzers with pre-selectors and quasi-peak detectors are used to perform radiated measurements.

Calibrated wideband preamplifiers, coaxial cables, and coaxial attenuators are also used for making measurements.

All receiving equipment conforms to CISPR Publication 16-1, "Radio Interference Measuring Apparatus and Measurement Methods."

3. TEST SPECIFICATIONS

3.1. STANDARDS

The following tests were conducted on a sample of the equipment for the purpose of demonstrating compliance with FCC Part 2, Part 30

Description	Reference	Results
Occupied Bandwidth	§ 2.1049	Compliant ^{Note}
EIRP Density	§ 30.202	Compliant ^{Note}
Conducted Output Power	§ 2.1046	Compliant ^{Note}
Band Edge	§ 2.1051, § 30.203	Compliant ^{Note}
Radiated Spurious Emissions	§ 2.1051, § 30.203	Compliant ^{Note}
Frequency Stability	§ 2.1055	Compliant ^{Note}

Note:

all of the 1CC ~ 4CC data contained herein is tested from the reference FCC ID : A3LHT5H01-60A report.
(Report No. HCT-RF-1908-FC024-R1)

3.2. ADDITIONAL DESCRIPTIONS ABOUT TEST

- All tests is performed by radiated measurement and applied below conditions.

: Used measurement distance with far field of test such as EIRP, OBW and Band edge are as follow.

$$\text{Wavelength} = \text{Speed of light} / \text{Measurement frequency} = 30 / 4\,000 = 0.0075$$

$$(2 \times (\text{Max measured antenna dimension})^2) / \text{Wavelength} = (2 \times (0.0960469)^2) / 0.0075 = 2.46 \text{ m}$$

So, measurement distance is 3.0 m.

: Spurious emissions measurement distance is shown in table below(Reference : Measurement Antenna Dimension).

Frequency Rage (GHz)	Wavelength (cm)	Far Field Distance (m)	Measurement Distance(m)
18 ~ 40	0.75	2.46	3.00
40 ~ 50	0.60	1.130	3.00
50 ~ 60	0.50	1.354	3.00
60 ~90	0.33	0.856	3.00
90 ~ 140	0.214	0.572	1.00
140 ~ 200	0.15	0.332	0.50

: Radiated test is performed on various angle of antenna and following location is worst test case.

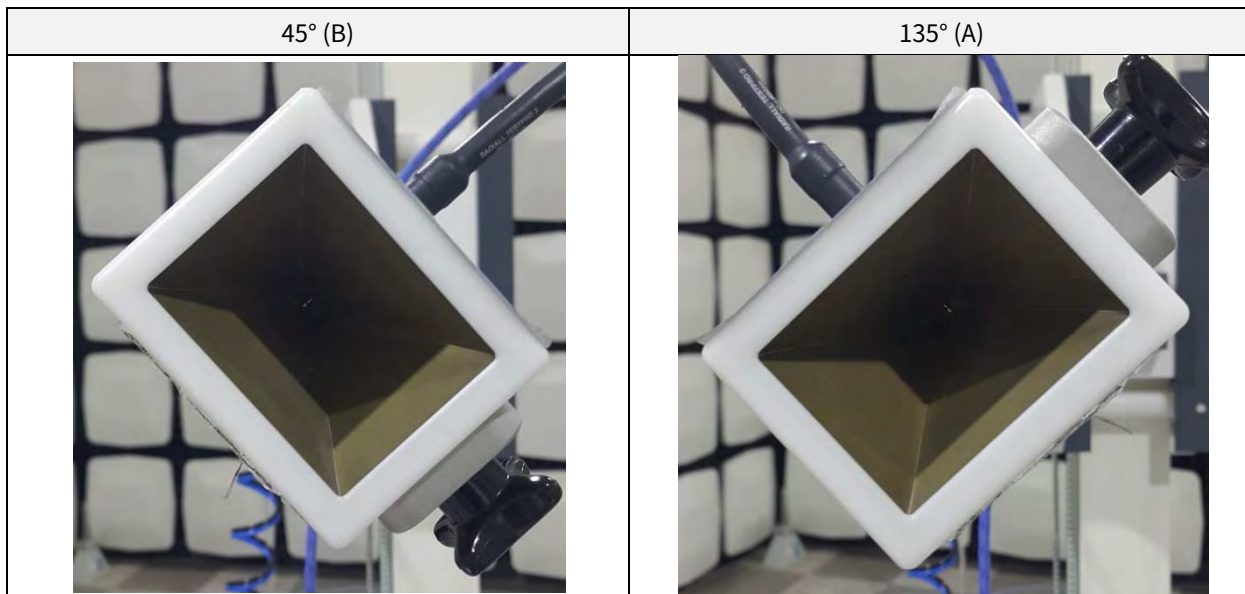

- CC means component carriers and EUT support 1 cc ~ 8 cc.

- Test was performed the carrier 1 and 8 case having maximum output power and maximum PSD(It means the worst case.).

- Unwanted radiated emissions test was performed on state of all EUT antenna path is operated with a maximum output power level.

- Transmitter output signals are correlated.

- In case of far-field distance for fundamental, we applied the measured antenna dimension because the measured antenna is bigger than the antenna of EUT.

- Because of the EUT using TDD technology, it cannot be configured to transmit continuously and measurement instrument cannot be configured to measure only during active transmissions. So we perform the measurement using duty cycle method.

- After pretesting in contiguous mode(5 CC, 6CC, 7CC and 8CC) and in non-contiguous mode (2CC to 8CC), 8CC in contiguous modes and 2 CC (1+1) in non-contiguous modes are shown in the following sections as the worst case.

- Total Power is the Highest in 8CC, and 1+1CC Mode is the worst case in both RSE and Bandedge tests in Non-Contiguous Mode.

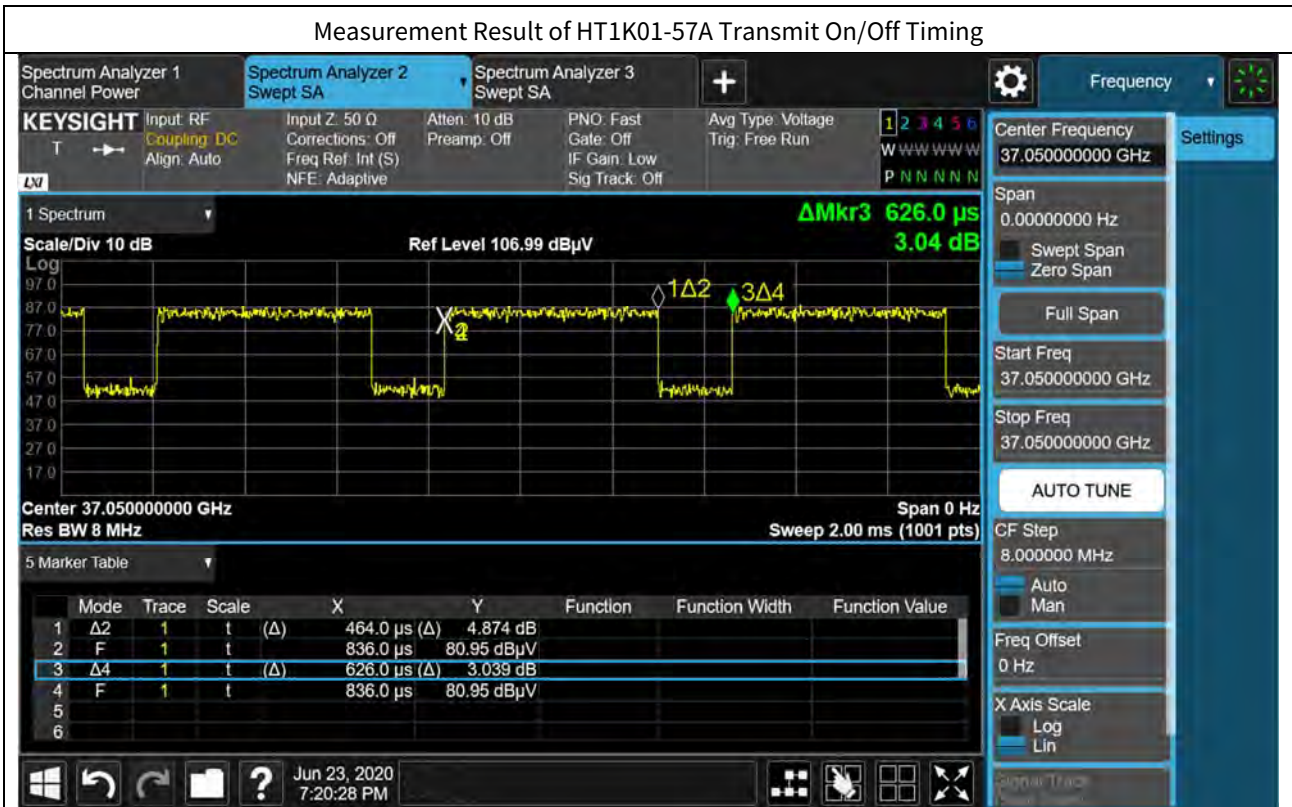

- The EUT duty cycle is calculated according to ANSI C63.26 - 5.2.4.3.4.

$$\text{Duty Cycle} = \text{On-time} / \text{Transmitter period} = 0.464 \text{ ms} / 0.626 \text{ ms} = 0.74$$

$$\text{Duty Correction} = 10 \log (1/\text{duty cycle}) = 10 \log (1/0.74) = 1.301 \text{ dB}$$

- All modulations(QPSK, 16QAM, 64QAM) were investigated and the worst case(64QAM) configuration results are reported.

3.3. MAXIMUM MEASUREMENT UNCERTAINTY

The value of the measurement uncertainty for the measurement of each parameter.

Coverage factor $k=2$, Confidence levels of 95 %

Description	Frequency	Uncertainty
Occupied Bandwidth	37 ~ 40 GHz	± 0.31 MHz
Conducted Output Power	37 ~ 40 GHz	± 5.05 dB
EIRP Density		
Band Edge		
Radiated Spurious Emissions	9 kHz ~ 30 MHz	± 3.40 dB
	30 MHz ~ 1 GHz	± 4.80 dB
	1 GHz ~ 18 GHz	± 5.70 dB
	18 GHz ~ 40 GHz	± 5.05 dB
	40 GHz ~ 200 GHz	± 4.59 dB
Frequency Stability	37 ~ 40 GHz	69.61 kHz

3.4. STANDARDS ENVIRONMENTAL TEST CONDITIONS

Temperature :	+15 °C to +35 °C
Relative humidity:	30 % to 60 %
Air pressure	860 mbar to 1 060 mbar

3.5. TEST DIAGRAMS

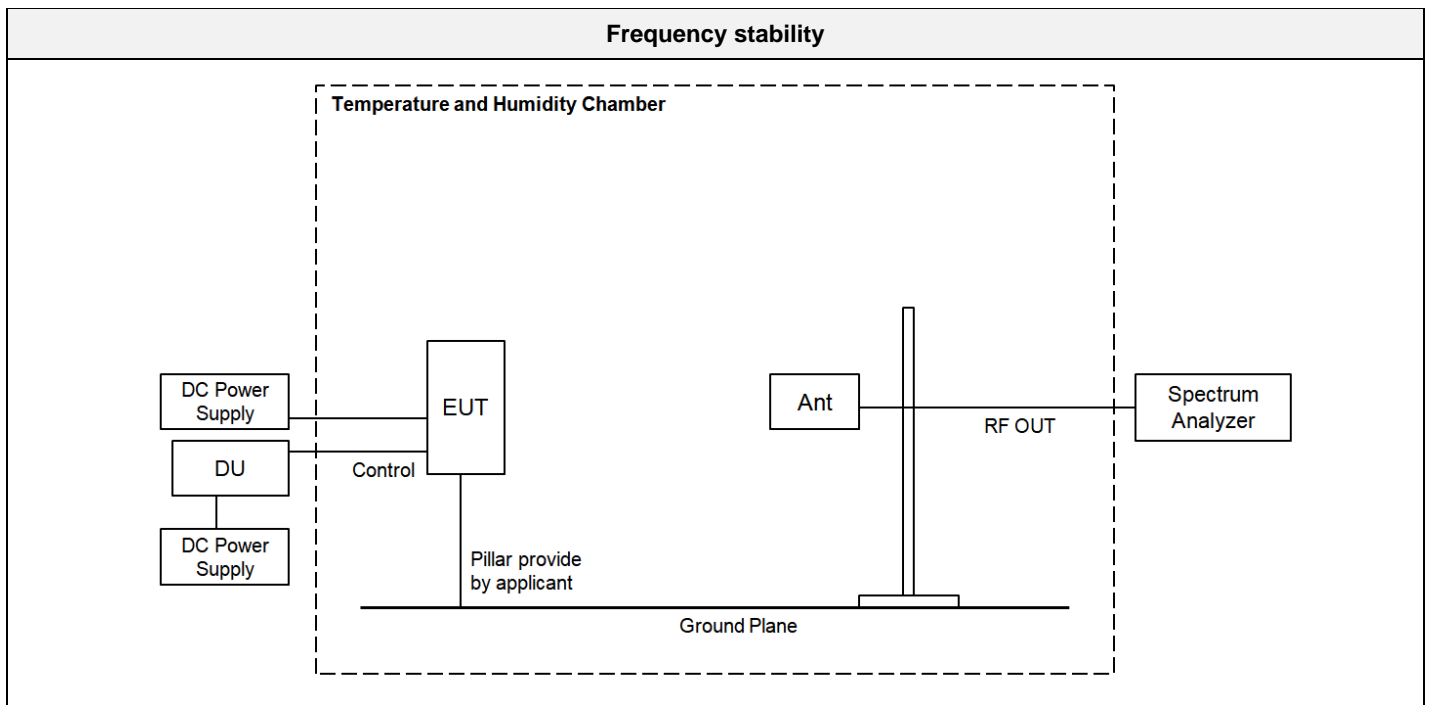
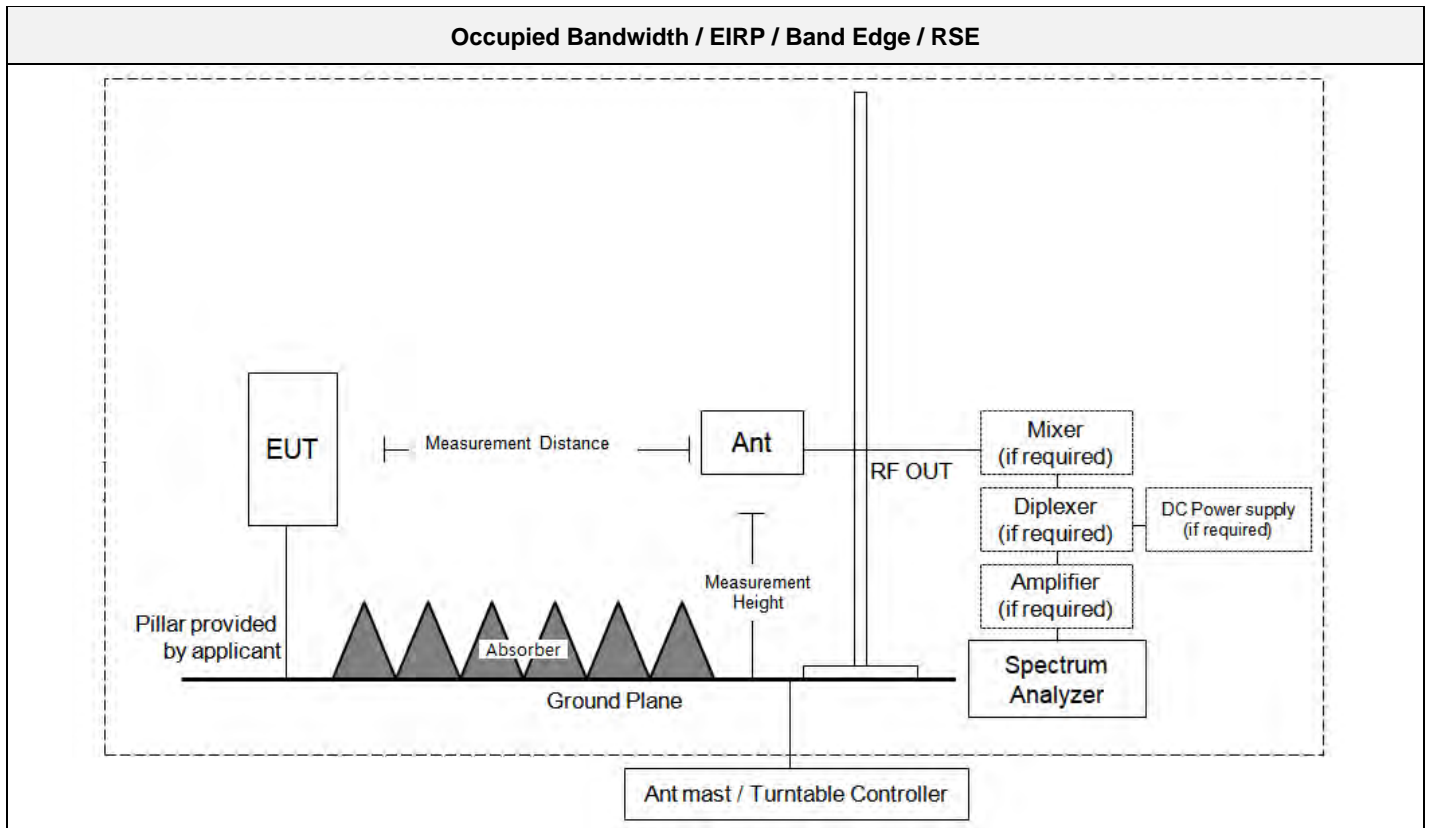

4. TEST EQUIPMENTS

Manufacturer	Model / Equipment	Calibration Date	Calibration Interval	Serial No.
Agilent	N9030B / PXA Signal Analyzer	06/04/2020	Annual	MY55480167
Schwarzbeck	BBHA 9170 / Horn Antenna	11/29/2019	Biennial	BBHA9170541
KIKUSUI	PWR800L / DC Power Supply	07/18/2019	Annual	RE002047
Innco system	CO3000 / Controller(Antenna mast)	N/A	N/A	CO3000-4p
Innco system	MA4640/800-XP-EP / Antenna Position Tower	N/A	N/A	N/A
Rohde&Schwarz	FSW / Spectrum Analyzer	09/09/2019	Annual	101256
Rohde&Schwarz	FSP / Spectrum Analyzer	09/11/2019	Annual	836650/016
Schwarzbeck	Loop Antenna	05/12/2020	Biennial	1513-175
Emco	2090 / Controller	N/A	N/A	060520
Ets	Turn Table	N/A	N/A	N/A
Schwarzbeck	VULB 9168 / Hybrid Antenna	08/31/2018	Biennial	9168-895
Schwarzbeck	BBHA 9120D / Horn Antenna	06/28/2019	Biennial	9120D-1300
OML INC.	WR-19 Horn Antenna / Horn Antenna	04/23/2020	Biennial	M19RH-160419-2
OML INC.	WR-19 Horn Antenna / Horn Antenna	04/23/2020	Biennial	M19RH-160419-1
OML INC.	WR-12 Horn Antenna / Horn Antenna	04/23/2020	Biennial	M12RH-160419-1
OML INC.	WR-12 Horn Antenna / Horn Antenna	04/23/2020	Biennial	M12RH-160419-2
OML INC.	WR-08 Horn Antenna / Horn Antenna	04/23/2020	Biennial	M08RH-160419-2
OML INC.	WR-08 Horn Antenna / Horn Antenna	04/23/2020	Biennial	M08RH-160419-1
OML INC.	WR-05 Horn Antenna / Horn Antenna	04/23/2020	Biennial	M05RH-160419-1
OML INC.	WR-05 Horn Antenna / Horn Antenna	04/23/2020	Biennial	M05RH-160419-2
OML INC.	OML WR19 / Harmonic Mixer	09/09/2019	Annual	M19HWD
OML INC.	OML WR12 / Harmonic Mixer	09/09/2019	Annual	M12HWD
OML INC.	OML WR08 / Harmonic Mixer	09/09/2019	Annual	W08HWD
OML INC.	OML WR05 / Harmonic Mixer	09/09/2019	Annual	M05HWD
OML INC.	WR-19 / Source Module	11/19/2019	Annual	S19MS-A-160516-1
OML INC.	WR-12 / Source Module	09/09/2019	Annual	S12MS-A-160419-1
OML INC.	WR-08 / Source Module	09/09/2019	Annual	S08MS-A-160419-1
OML INC.	WR-05 / Source Module	07/22/2019	Annual	S05MS-A-160419-1
NANGYEUL CO., LTD.	NY-THR18750 / Temperature and Humidity Chamber	12/16/2019	Annual	NY-200912201A
Rohde & Schwarz	SMV100A / Signal Generator	07/15/2019	Annual	177633

Note:

1. Equipment listed above that calibrated during the testing period was set for test after the calibration.
2. Equipment listed above that has a calibration due date during the testing period, the testing is completed before equipment expiration date.

5. TEST RESULT

5.1. OCCUPIED BANDWIDTH

FCC Rules

Test Requirements:

§ 2.1049 Measurements required: Occupied bandwidth.

The occupied bandwidth, that is the frequency bandwidth such that, below its lower and above its upper frequency limits, the mean powers radiated are each equal to 0.5 percent of the total mean power radiated by a given emission shall be measured under the specified conditions of § 2.1049 (a) through (i) as applicable.

Test Procedures:

The measurement is performed in accordance with Section 5.4.3 and 5.4.4 of ANSI C63.26.

5.4.3 Occupied bandwidth—Relative measurement procedure

a) The spectrum analyzer center frequency is set to the nominal EUT channel center frequency. The span range for the spectrum analyzer shall be wide enough to see sufficient roll off of the signal to make the measurement.

b) The nominal RBW shall be in the range of 1% to 5% of the anticipated OBW, and the VBW shall be set $\geq 3 \times$ RBW.

c) Set the reference level of the instrument as required to prevent the signal amplitude from exceeding the maximum spectrum analyzer input mixer level for linear operation. See guidance provided in 4.2.3.

NOTE—Step a), step b), and step c) may require iteration to adjust within the specified tolerances.

d) The dynamic range of the spectrum analyzer at the selected RBW shall be more than 10 dB below the target “–X dB” requirement, i.e., if the requirement calls for measuring the –26 dB OBW, the spectrum analyzer noise floor at the selected RBW shall be at least 36 dB below the reference level.

e) Set spectrum analyzer detection mode to peak, and the trace mode to max hold.

f) Determine the reference value by either of the following:

1) Set the EUT to transmit a modulated signal. Allow the trace to stabilize. Set the spectrum analyzer marker to the highest level of the displayed trace (this is the reference value).

2) Set the EUT to transmit an unmodulated carrier. Set the spectrum analyzer marker to the level of the carrier.

g) Determine the “–X dB amplitude” as equal to (Reference Value – X). Alternatively, this calculation can be performed on the spectrum analyzer using the delta-marker measurement function.

h) If the reference value was determined using an unmodulated carrier, turn the EUT modulation on, then either clear the existing trace or start a new trace on the spectrum analyzer and allow the new trace to stabilize. Otherwise the trace from step f) shall be used for step i).

i) Place two markers, one at the lowest and the other at the highest frequency of the envelope of the spectral display such that each marker is at or slightly below the “–X dB amplitude” determined in step f). If a marker is below this “–X dB amplitude” value it should be as close as possible to this value. The OBW is the positive frequency difference between the two markers. The spectral envelope can cross the “–X dB amplitude” at multiple points. The lowest or highest frequency shall be selected as the frequencies that are the farthest away from the center frequency at which the spectral envelope crosses the “–X dB amplitude.”

j) The OBW shall be reported by providing plot(s) of the measuring instrument display, to include markers depicting the relevant frequency and amplitude information (e.g., marker table). The frequency and amplitude axis and scale shall be clearly labeled. Tabular data may be reported in addition to the plot(s).

5.4.4 Occupied bandwidth—Power bandwidth (99%) measurement procedure

a) The spectrum analyzer center frequency is set to the nominal EUT channel center frequency. The frequency span for the spectrum analyzer shall be set wide enough to capture all modulation products including the emission skirts (typically a span of $1.5 \times$ OBW is sufficient).

b) The nominal IF filter 3 dB bandwidth (RBW) shall be in the range of 1% to 5% of the anticipated OBW, and the VBW shall

be set $\geq 3 \times \text{RBW}$.

c) Set the reference level of the instrument as required to prevent the signal amplitude from exceeding the maximum spectrum analyzer input mixer level for linear operation. See guidance provided in 4.2.3.

NOTE—Step a), step b), and step c) may require iteration to adjust within the specified tolerances.

d) Set the detection mode to peak, and the trace mode to max-hold.

e) If the instrument does not have a 99% OBW function, recover the trace data points and sum directly in linear power terms. Place the recovered amplitude data points, beginning at the lowest frequency, in a running sum until 0.5% of the total is reached. Record that frequency as the lower OBW frequency. Repeat the process until 99.5% of the total is reached and record that frequency as the upper OBW frequency. The 99% power OBW can be determined by computing the difference these two frequencies.

f) The OBW shall be reported and plot(s) of the measuring instrument display shall be provided with the test report. The frequency and amplitude axis and scale shall be clearly labeled. Tabular data can be reported in addition to the plot(s).

Test Results:
Tabular Data of Occupied Bandwidth
1. Contiguous

Ant.	Ant. Angle	CC	Channel	Mod.	Measured OBW (MHz)
A	135°	8	Middle	QPSK	788.337
				64QAM	787.272
B	45°			QPSK	788.277
				64QAM	787.047

2. Non-Contiguous

Ant.	Ant. Angle	CC	Channel	Mod.	Measured OBW (MHz)		
					Left	Right	SUM
A	135°	1+1	Middle	QPSK	94.279	94.241	188.521
				64QAM	94.322	94.316	188.639
B	45°			QPSK	94.451	94.223	188.674
				64QAM	94.431	94.324	188.755

Plot Data of RF Occupied Bandwidth

Antenna A / 8cc / QPSK / Middle / Contiguous

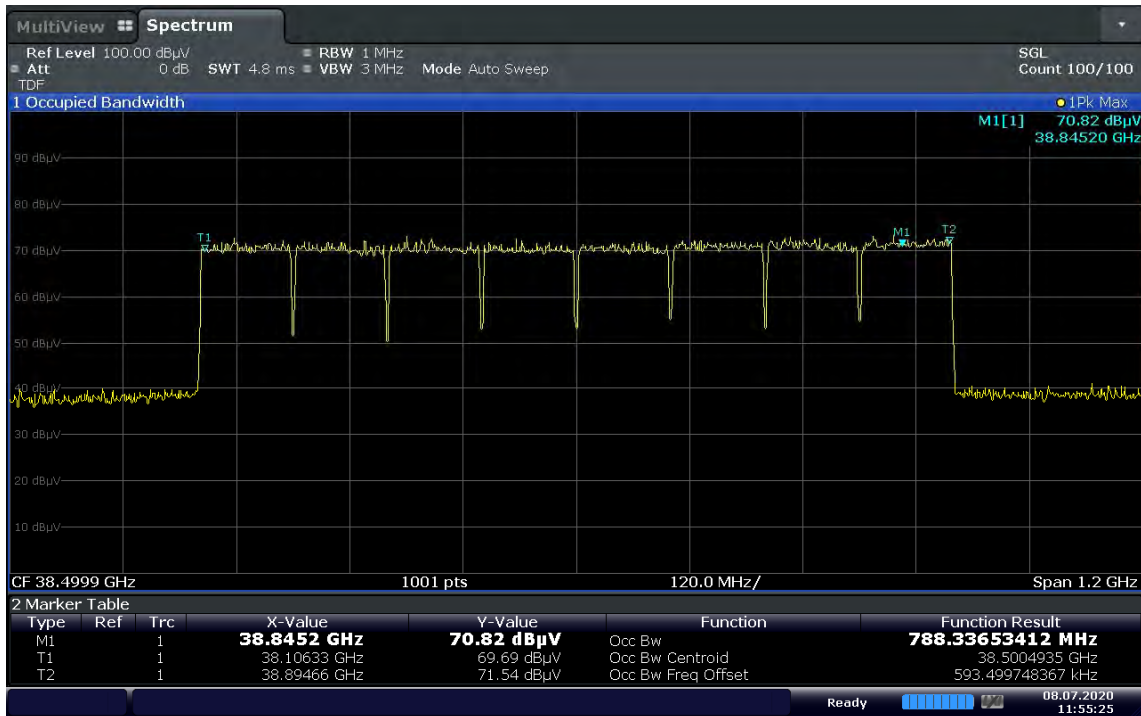

11:55:25 08.07.2020

Antenna A / 8cc / 64QAM / Middle / Contiguous



Antenna B / 8cc / QPSK / Middle / Contiguous

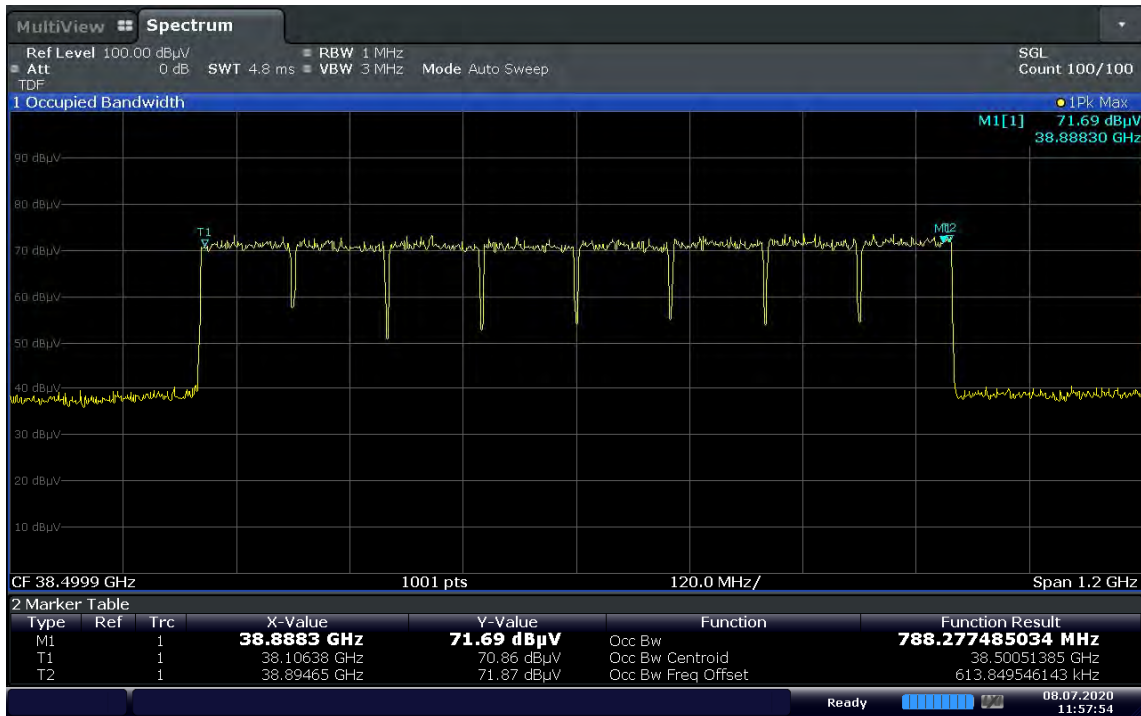

11:57:54 08.07.2020

Antenna B / 8cc / 64QAM / Middle / Contiguous

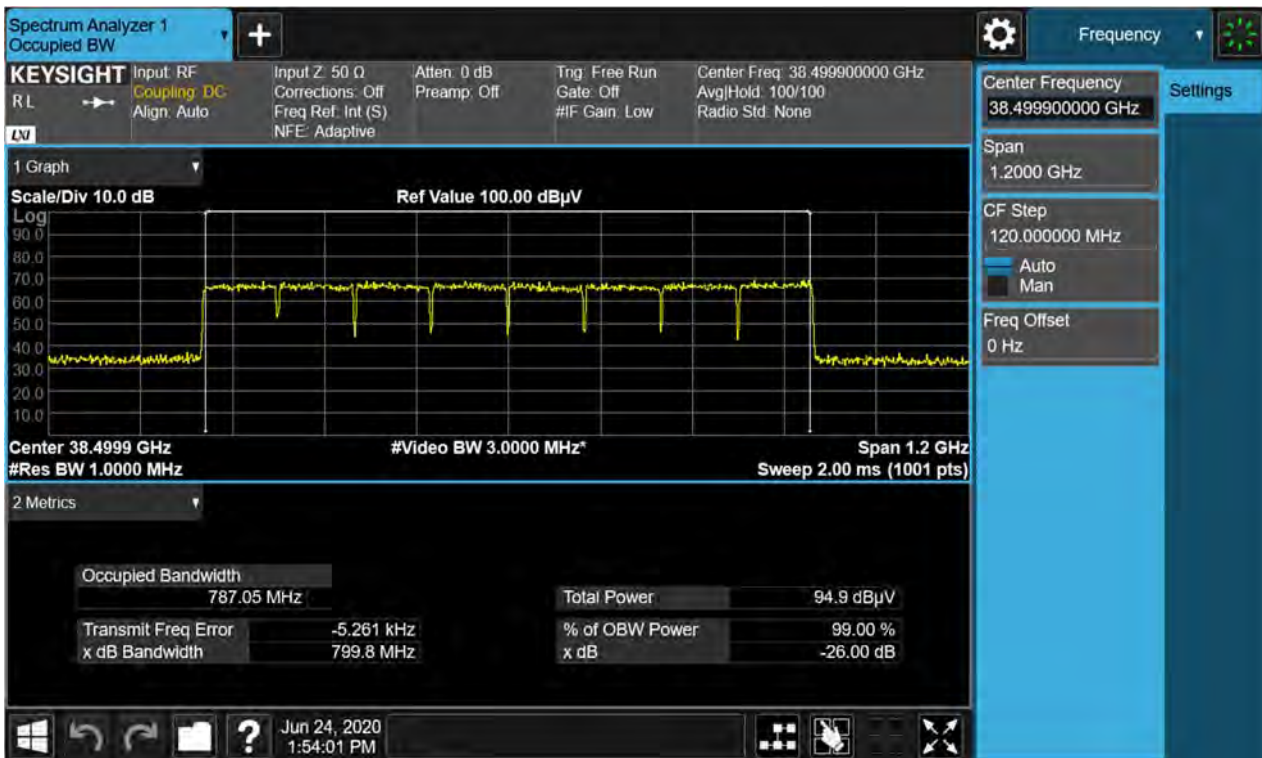

Antenna A / 1cc + 1cc / QPSK / Middle / Non-Contiguous / Left



14:39:49 08.07.2020

Antenna A / 1cc + 1cc / QPSK / Middle / Non-Contiguous / Right



14:40:18 08.07.2020

Antenna A / 1cc + 1cc / 64QAM / Middle / Non-Contiguous / Left

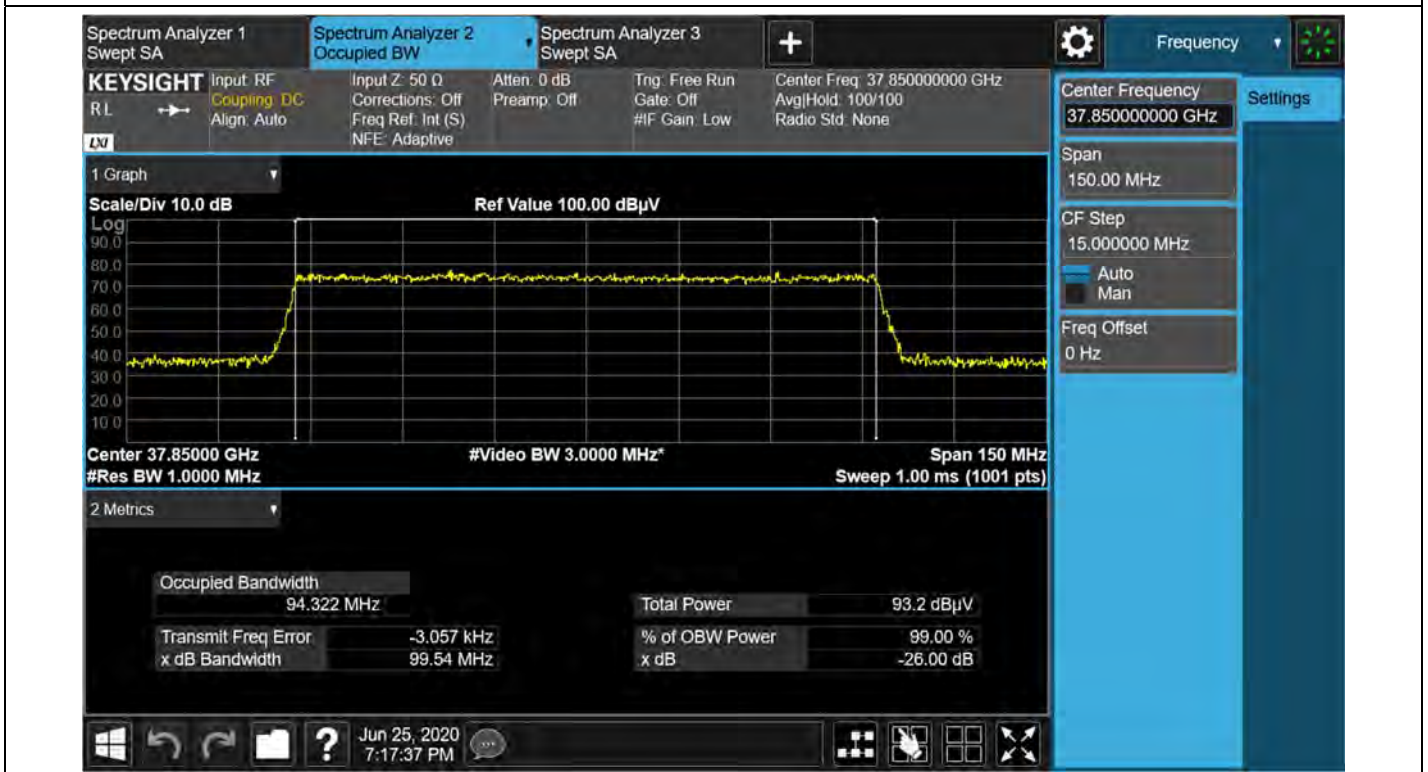

Antenna A / 1cc + 1cc / 64QAM / Middle / Non-Contiguous / Right

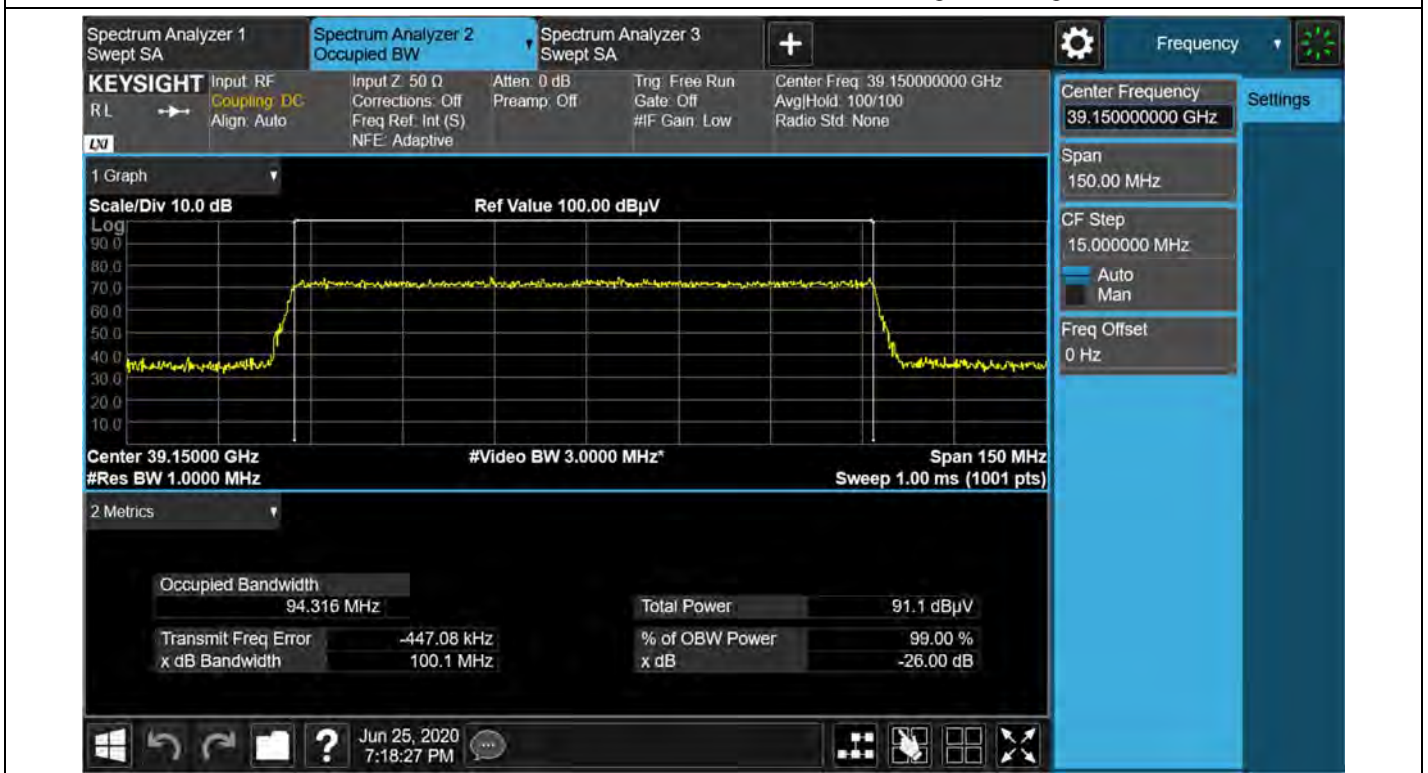

Antenna B / 1cc + 1cc / QPSK / Middle / Non-Contiguous/ Left



14:39:00 08.07.2020

Antenna B / 1cc + 1cc / QPSK / Middle / Non-Contiguous/ Right

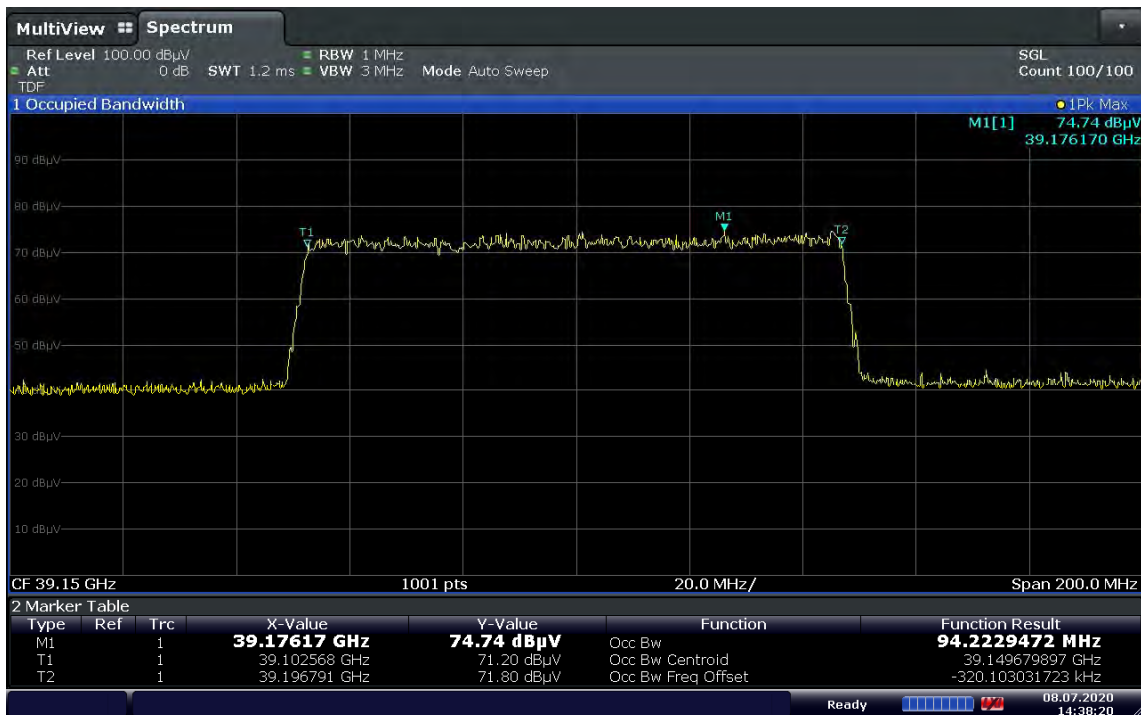

14:38:20 08.07.2020

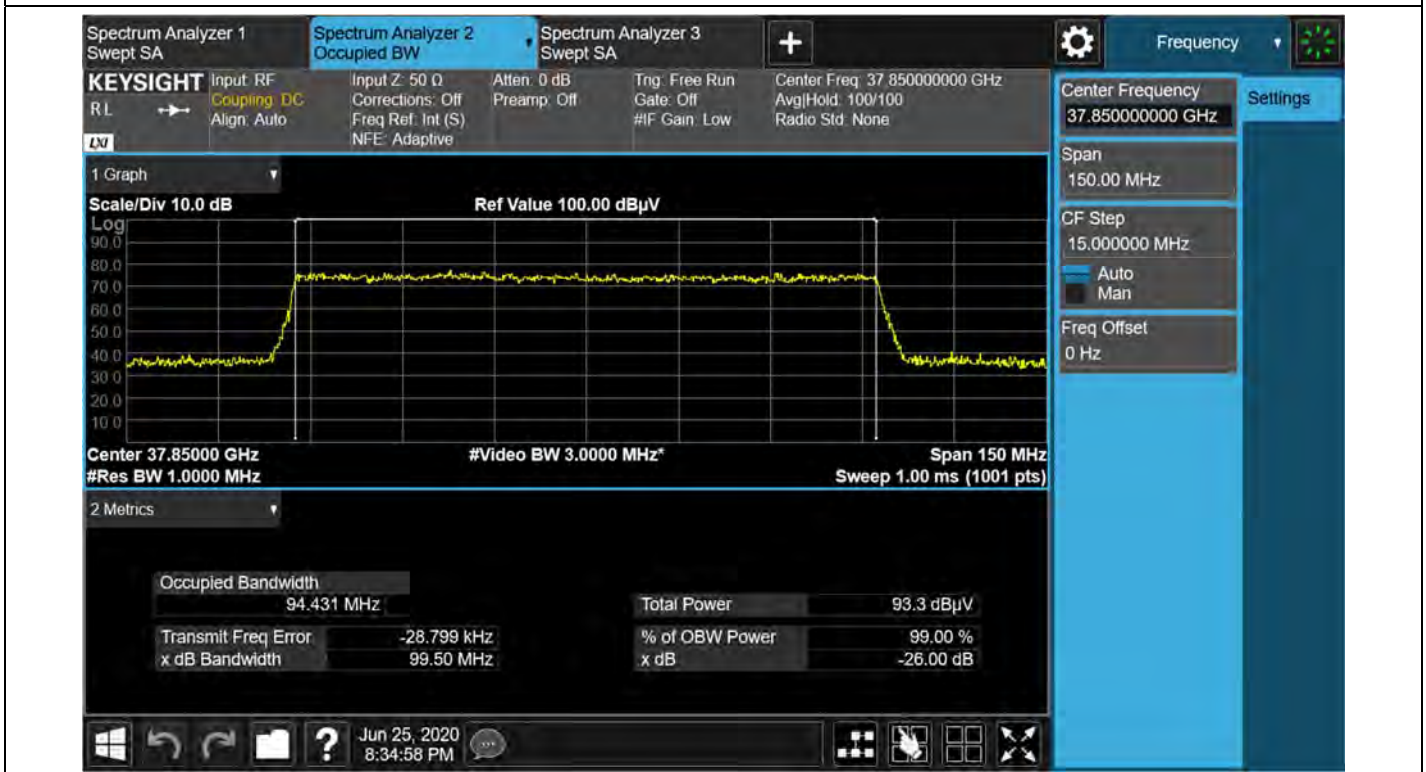
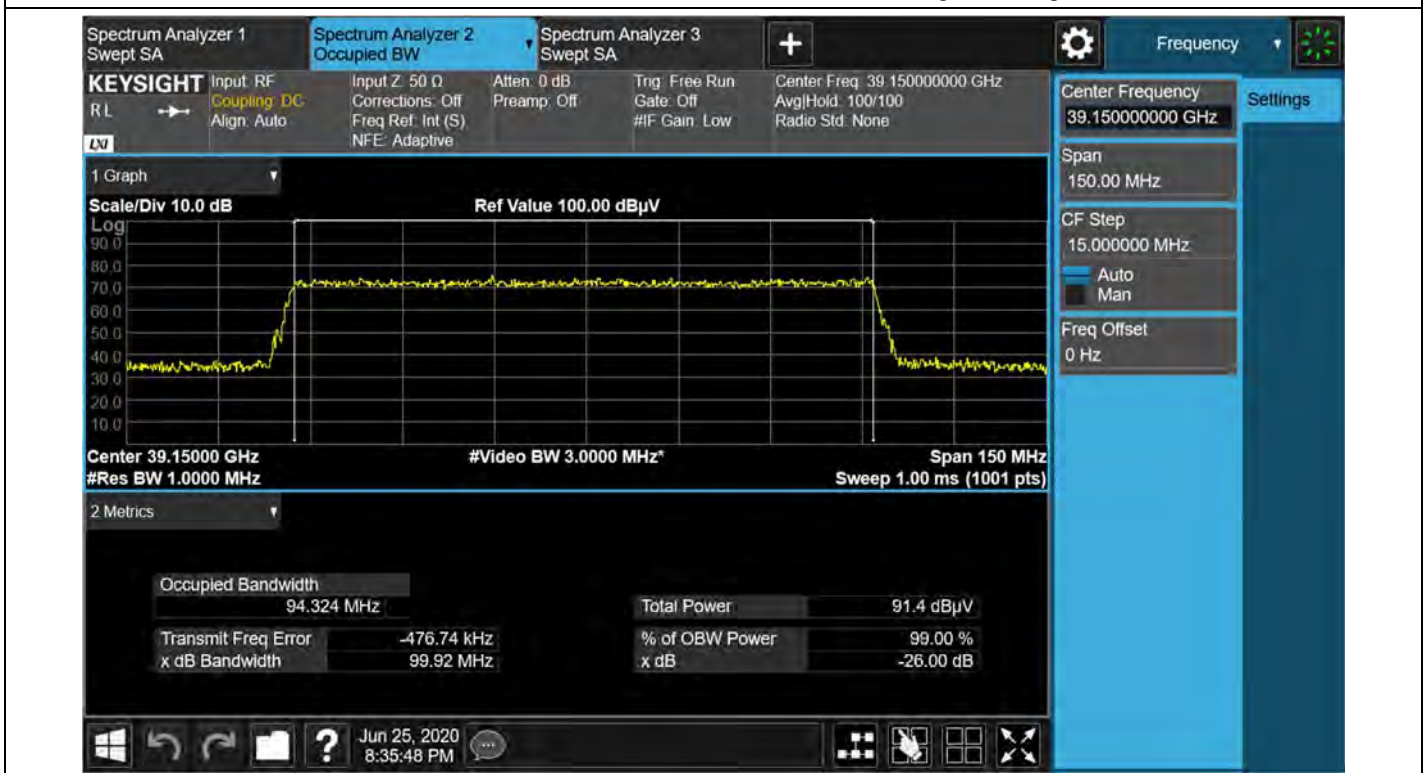
Antenna B / 1cc + 1cc / 64QAM / Middle / Non-Contiguous/ Left

Antenna B / 1cc + 1cc / 64QAM / Middle / Non-Contiguous/ Right

5.2. EIRP DENSITY

FCC Rules

Test Requirements:

§ 30.202 Power limits.

(a) For fixed and base stations operating in connection with mobile systems, the average power of the sum of all antenna elements is limited to an equivalent isotopically radiated power (EIRP) density of +75dBm/100 MHz. For channel bandwidths less than 100 megahertz the EIRP must be reduced proportionally and linearly based on the bandwidth relative to 100 megahertz.

Test Procedures:

The measurement is performed in accordance with Section 5.2.4.4.2 of ANSI C63.26.

- a) Set span to 2 × to 3 × the OBW.
- b) Set RBW = 1% to 5% of the OBW.
- c) Set VBW ≥ 3 × RBW.
- d) Set number of measurement points in sweep ≥ 2 × span / RBW.
- e) Sweep time:
 - 1) Set = auto-couple, or
 - 2) Set ≥ [10 × (number of points in sweep) × (transmission symbol period)] for single sweep (automation-compatible) measurement.
- f) Detector = power averaging (rms).
- g) Set sweep trigger to “free run.”
- h) Trace average at least 100 traces in power averaging (rms) mode if sweep is set to auto-couple. To accurately determine the average power over the on and off time of the transmitter, it can be necessary to increase the number of traces to be averaged above 100, or if using a manually configured sweep time, increase the sweep time.
- i) Compute power by integrating the spectrum across the OBW of the signal using the instrument’s band or channel power measurement function with band/channel limits set equal to the OBW band edges. If the instrument does not have a band or channel power function, sum the spectrum levels (in linear power units) at intervals equal to the RBW extending across the entire OBW of the spectrum.
- j) Add 10 log (1/duty cycle) to the measured power level to compute the average power during continuous transmission.

Note:

- 1) Test distance is determined to 3.0 m by far field condition; see test descriptions on page 8.
- 2) In this test, EUT is operated only measurement path is turned on and path has straight beamforming.
- 3) For 4 cc measurement, test is performed for all carriers of 100 MHz bandwidth, but recorded only maximum output level.
- 4) The angle of antenna is set as maximum radiated power conditions.
- 5) EIRP is calculated from measured value according to section 5.2.7 of ANSI C62.26-2015, and the formula is as follows.

$$\begin{aligned} EIRP (dBm) &= E (dB\mu V/m) + 20\log(3m) - 104.77 \\ &= E (dB\mu V/m) - 95.23 \end{aligned}$$

- 6) E (dB μ V/m) value is considered AFCL and Duty cycle factor and it as follow.

$$\begin{aligned} E \text{ (dB}\mu\text{V/m)} &= \text{measurement value (dB}\mu\text{V)} + \text{AFCL (37.05 GHz)} + \text{Duty cycle correction (60 \%)} \\ &= \text{measurement value (dB}\mu\text{V)} + 49.26 + 1.301 \end{aligned}$$

- 7) The output tolerance of the EUT in the specification is ± 4 dB and test result satisfies this condition.

- 8) Sample calculation:

Contiguous

$$\begin{aligned} 82.24 \text{ dB}\mu\text{V (measured Value)} + 9.54(\text{distance}) - 104.77 + 49.26(\text{AFCL}) + 1.301 (\text{Duty}) \\ = 37.57 \text{ dBm (Final EIRP)} \end{aligned}$$

Non-Contiguous

$$\begin{aligned} 88.09 \text{ dB}\mu\text{V (measured Value)} + 9.54(\text{distance}) - 104.77 + 49.28(\text{AFCL}) + 1.301 (\text{Duty}) \\ = 43.44 \text{ dBm (Final EIRP)} \end{aligned}$$

- 9) All modes of operation and modulations were investigated. The test results included in this sections are worst case emission in each emission designator W7D, G7D.

Test Results:
1. Contiguous
Tabular Data of EIRP Density per path

Ant.	Ant.	CC	Channel	Frequency (GHz)	Mod.	Measured Level	Limit (dBm)	Calculated EIRP (dBm)
	Angle					(dBuV)		
A	135°	8	Low	37.34988	QPSK	81.96	75	37.29
					64QAM	82.24		37.57
			Middle	38.84976	QPSK	80.34		37.01
					64QAM	80.42		37.09
			High	39.94992	QPSK	79.33		39.33
					64QAM	79.47		39.47
B	45°	8	Low	37.34988	QPSK	81.77	37.10	
					64QAM	82.14	37.47	
			Middle	38.84976	QPSK	80.79	37.46	
					64QAM	80.86	37.53	
			High	39.94992	QPSK	79.70	39.70	
					64QAM	79.72	39.72	

Tabular Data of SUM EIRP Density

Ant.	CC	Channel	Mod.	Ant A EIRP (dBm)	Ant B EIRP (dBm)	Limit (dBm)	Calculated EIRP (dBm)
A+B	8	Low	QPSK	37.29	37.10	75	40.21
			64QAM	37.57	37.47		40.54
		Middle	QPSK	37.01	37.46		40.25
			64QAM	37.09	37.53		40.33
		High	QPSK	39.33	39.70		42.53
			64QAM	39.47	39.72		42.61

2. Non-Contiguous

Tabular Data of EIRP Density per path

Ant.	Ant.	CC	Channel	Frequency (GHz)	Mod.	Measured Level	Limit (dBm)	Calculated EIRP (dBm)
	Angle					(dBuV)		
A	135°	1+1	Low	37.05	QPSK	86.38	75	41.73
					64QAM	86.60		41.95
			Mid	37.85	QPSK	84.21		40.88
					64QAM	84.66		41.33
			High	38.65	QPSK	82.96		42.19
					64QAM	83.17		42.41
B	45°	1+1	Low	37.05	QPSK	85.78	41.13	
					64QAM	85.95	41.30	
			Mid	37.85	QPSK	84.23	40.90	
					64QAM	84.58	41.25	
			High	37.65	QPSK	82.92	42.15	
					64QAM	83.15	42.38	

Tabular Data of SUM EIRP Density

Ant.	CC	Channel	Mod.	Ant A EIRP (dBm)	Ant B EIRP (dBm)	Limit (dBm)	Calculated EIRP (dBm)
A+B	8	Low	QPSK	41.73	41.13	75	44.45
			64QAM	41.95	41.30		44.65
		Middle	QPSK	40.88	40.90		43.90
			64QAM	41.33	41.25		44.30
		High	QPSK	42.19	42.15		45.18
			64QAM	42.41	42.38		45.40

Plot Data of EIRP Density Tabular per path

Antenna A / 8cc / QPSK / Low / Contiguous

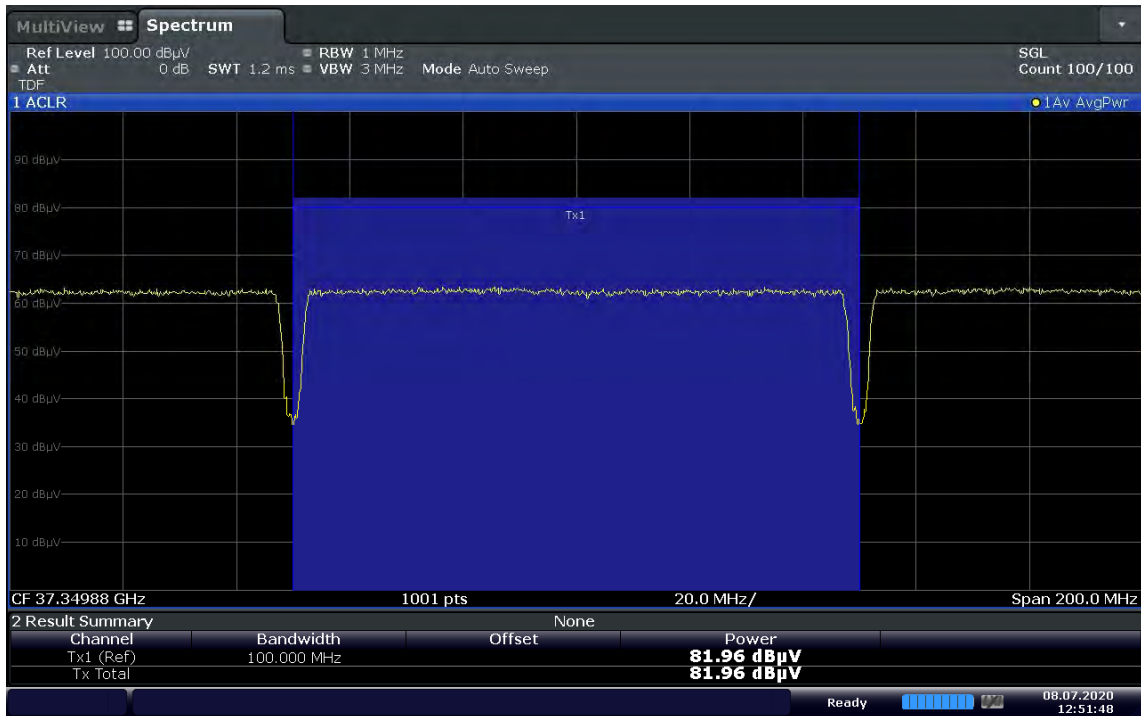

12:51:49 08.07.2020

Antenna A / 8cc / 64QAM / Low / Contiguous



Antenna A / 8cc / QPSK / Middle / Contiguous

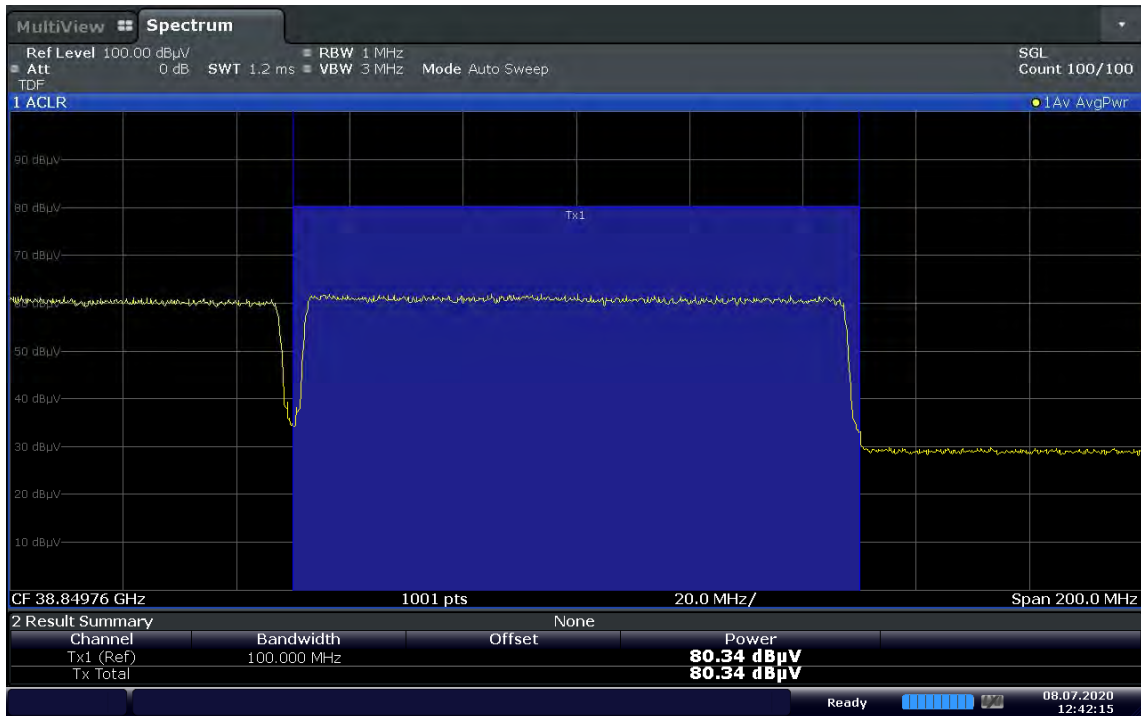

12:42:16 08.07.2020

Antenna A / 8cc / 64QAM / Middle / Contiguous



Antenna A / 8cc / QPSK / High / Contiguous

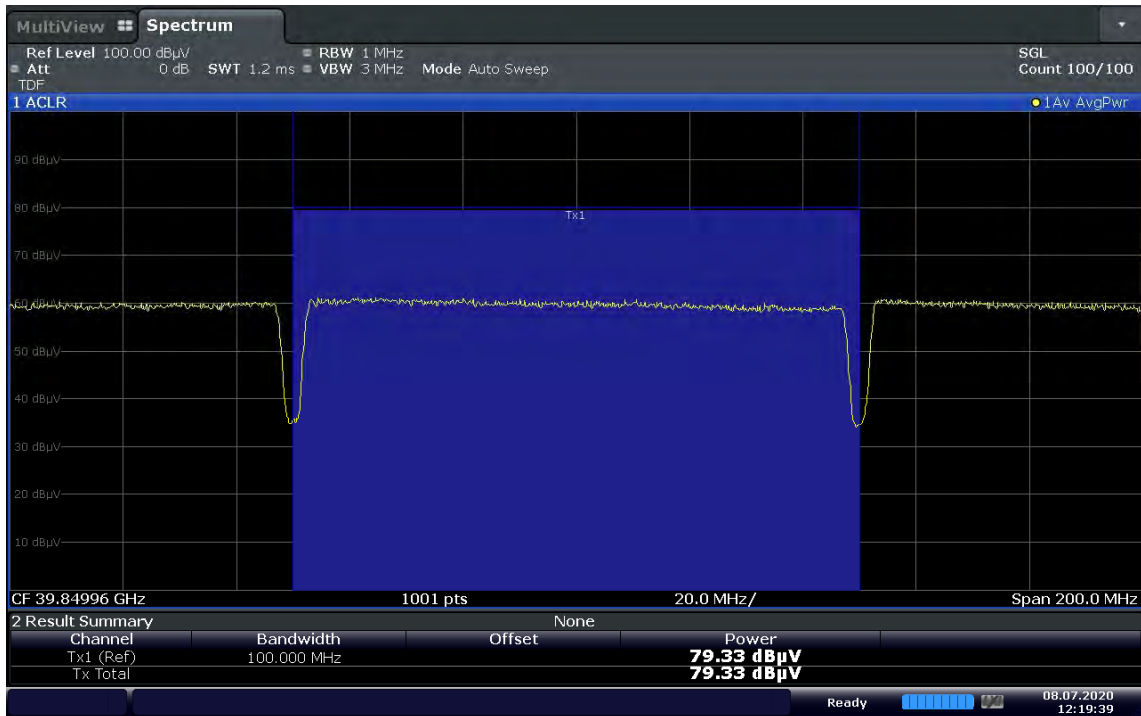

12:19:39 08.07.2020

Antenna A / 8cc / 64QAM / High / Contiguous



Antenna B / 8cc / QPSK / Low / Contiguous

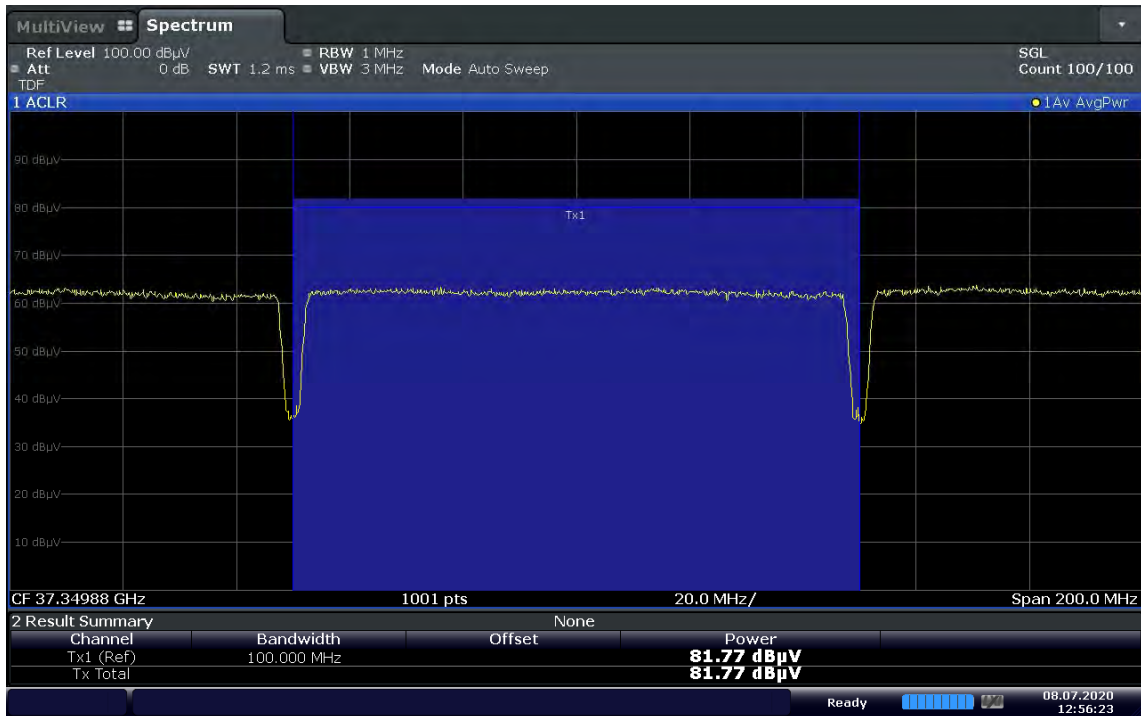

12:56:24 08.07.2020

Antenna B / 8cc / 64QAM / Low / Contiguous

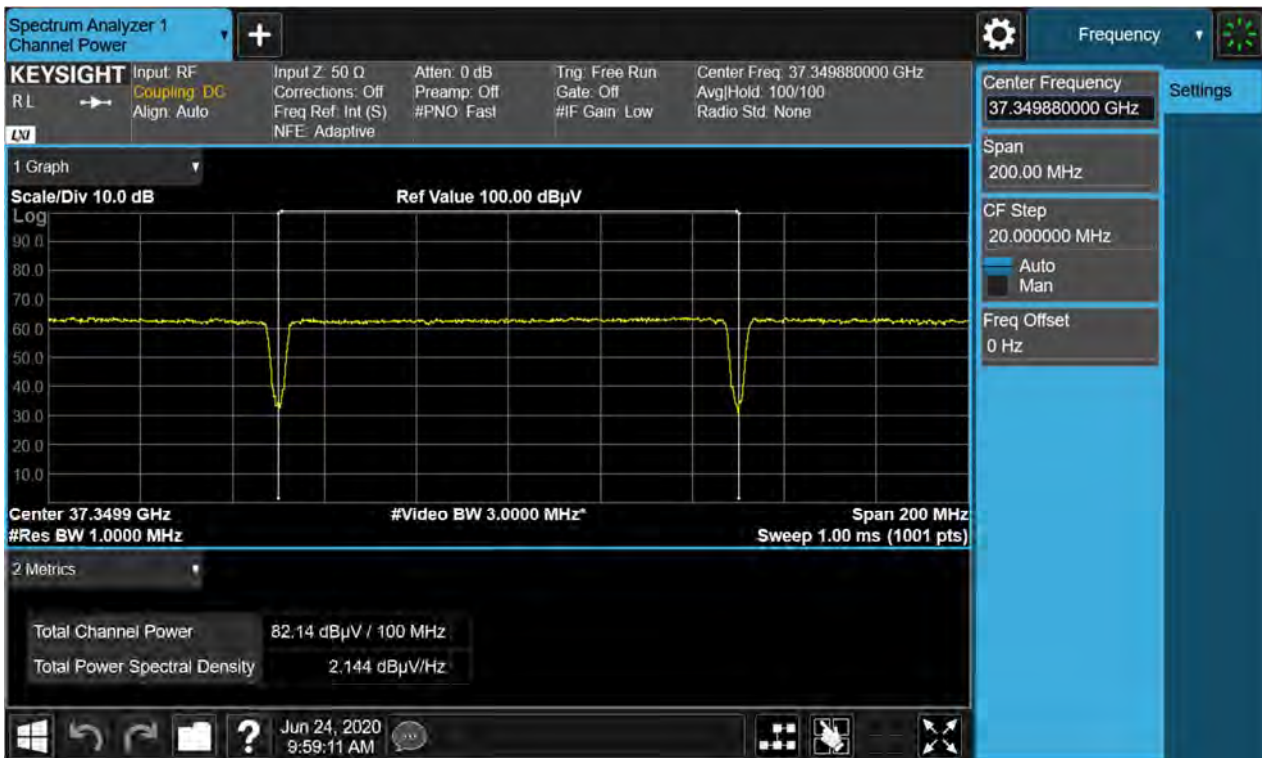

Antenna B / 8cc / QPSK / Middle / Contiguous

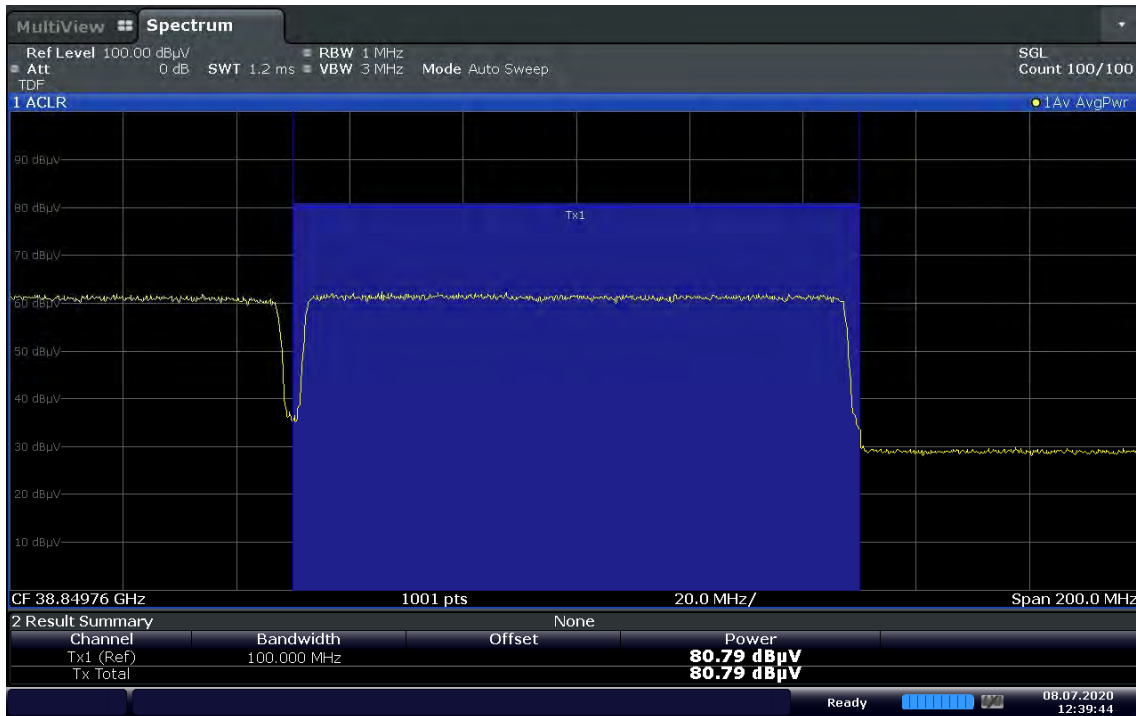

12:39:45 08.07.2020

Antenna B / 8cc / 64QAM / Middle / Contiguous



Antenna B / 8cc / QPSK / High / Contiguous

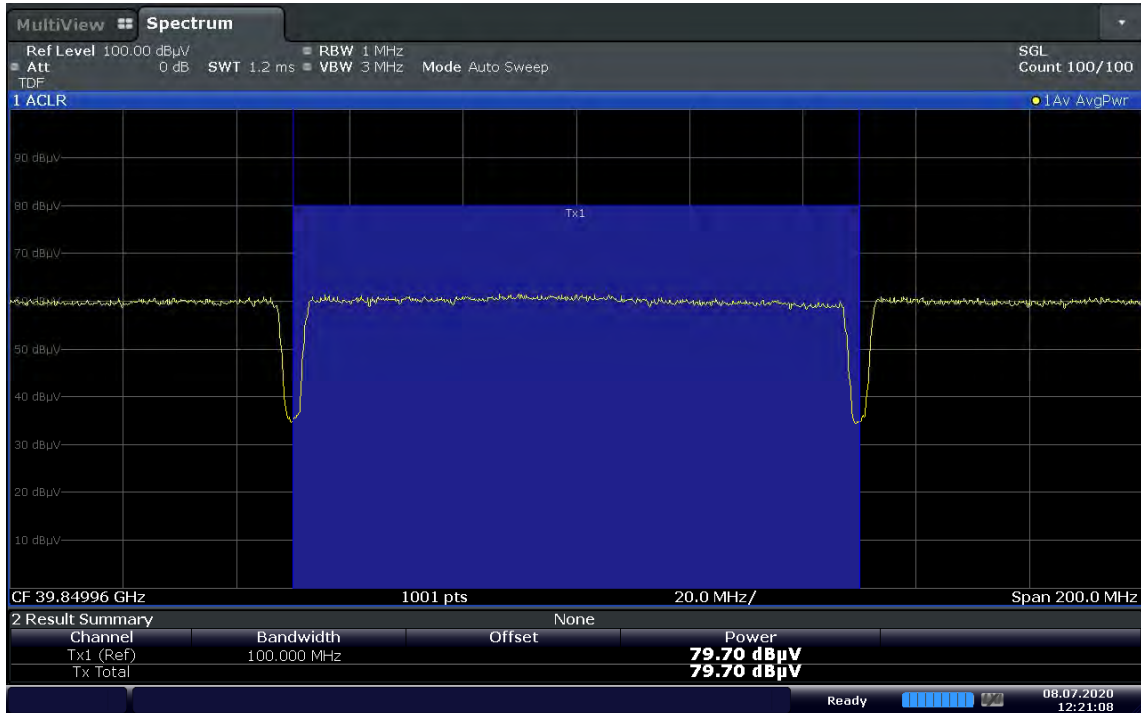

12:21:08 08.07.2020

Antenna B / 8cc / 64QAM / High / Contiguous

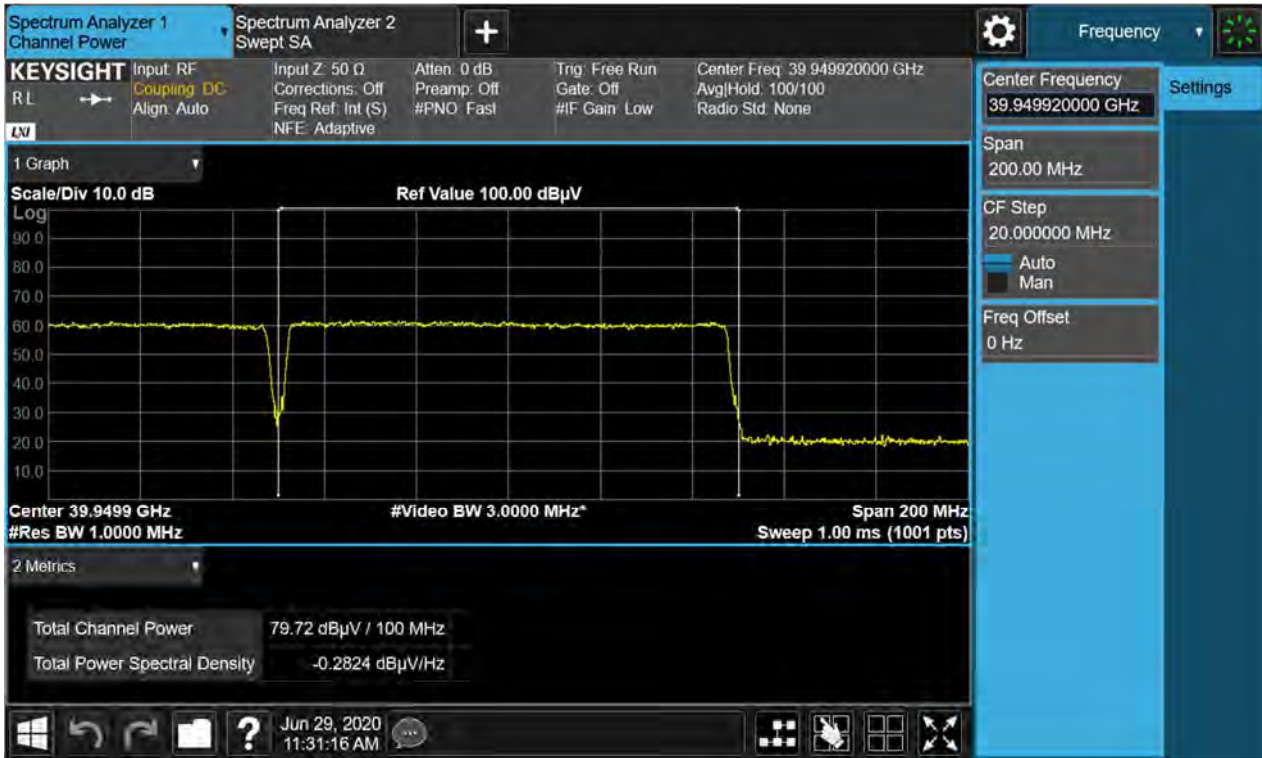

Antenna A / 1cc + 1cc / QPSK / Low / Non-Contiguous

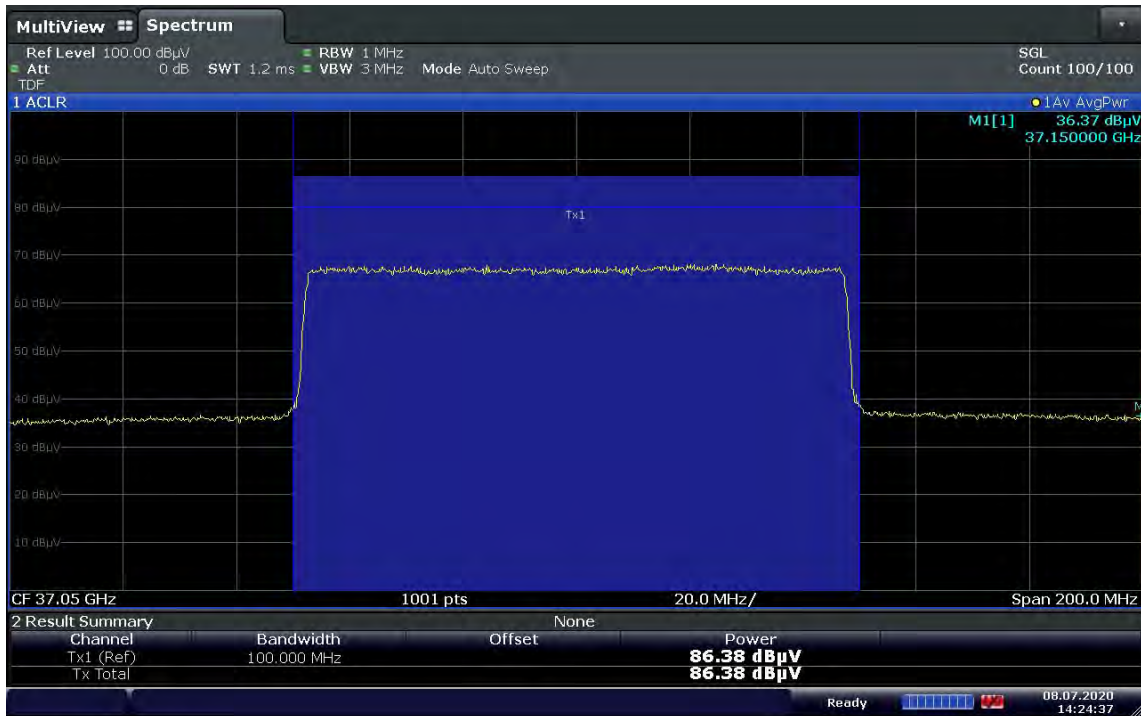

14:24:37 08.07.2020

Antenna A / 1cc + 1cc / 64QAM / Low / Non-Contiguous



Antenna A / 1cc + 1cc / QPSK / Middle / Non-Contiguous

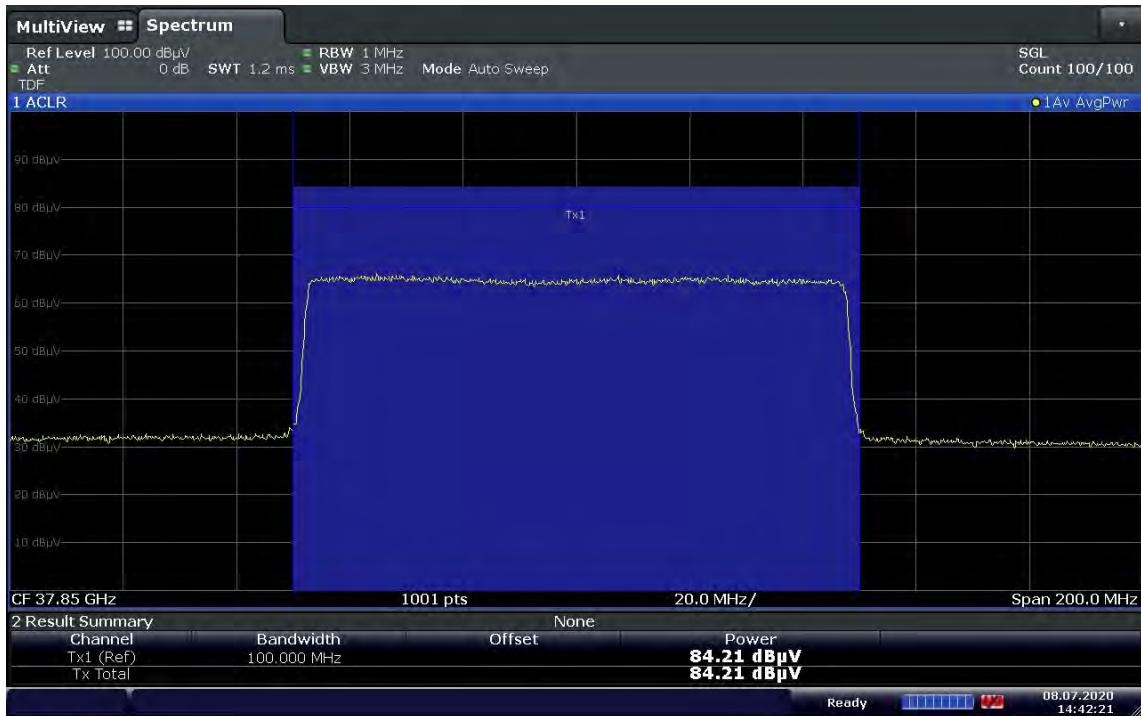

14:42:22 08.07.2020

Antenna A / 1cc + 1cc / 64QAM / Middle / Non-Contiguous



Antenna A / 1cc + 1cc / QPSK / High / Non-Contiguous

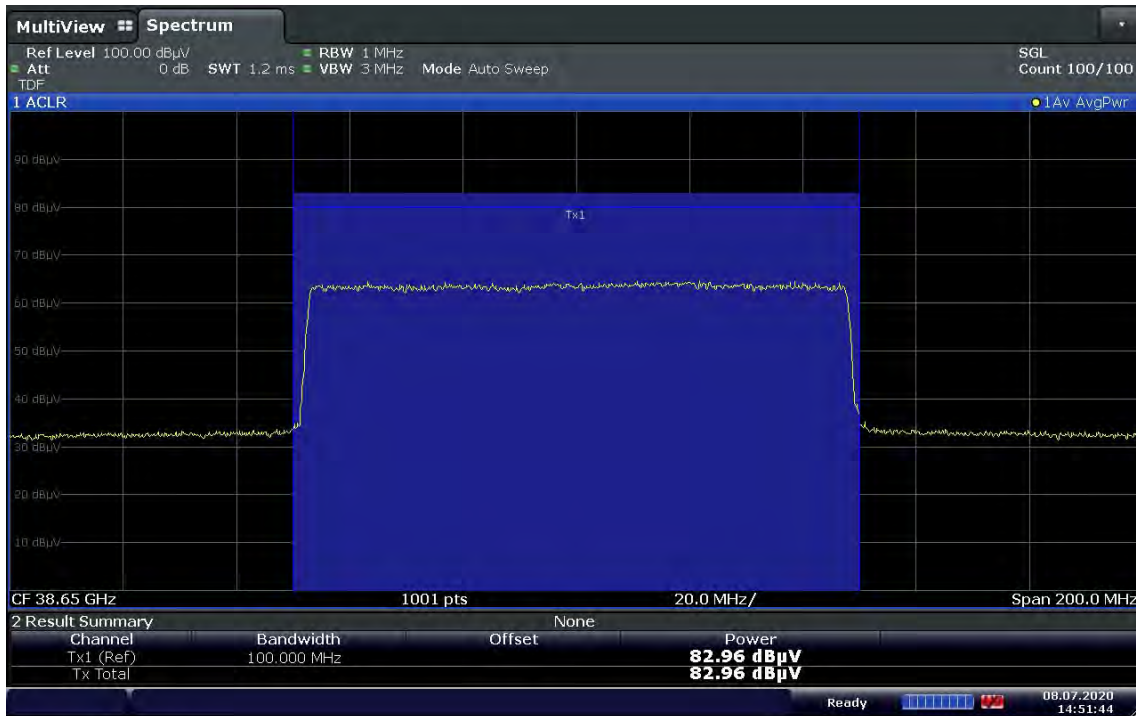

14:51:45 08.07.2020

Antenna A / 1cc + 1cc / 64QAM / High / Non-Contiguous

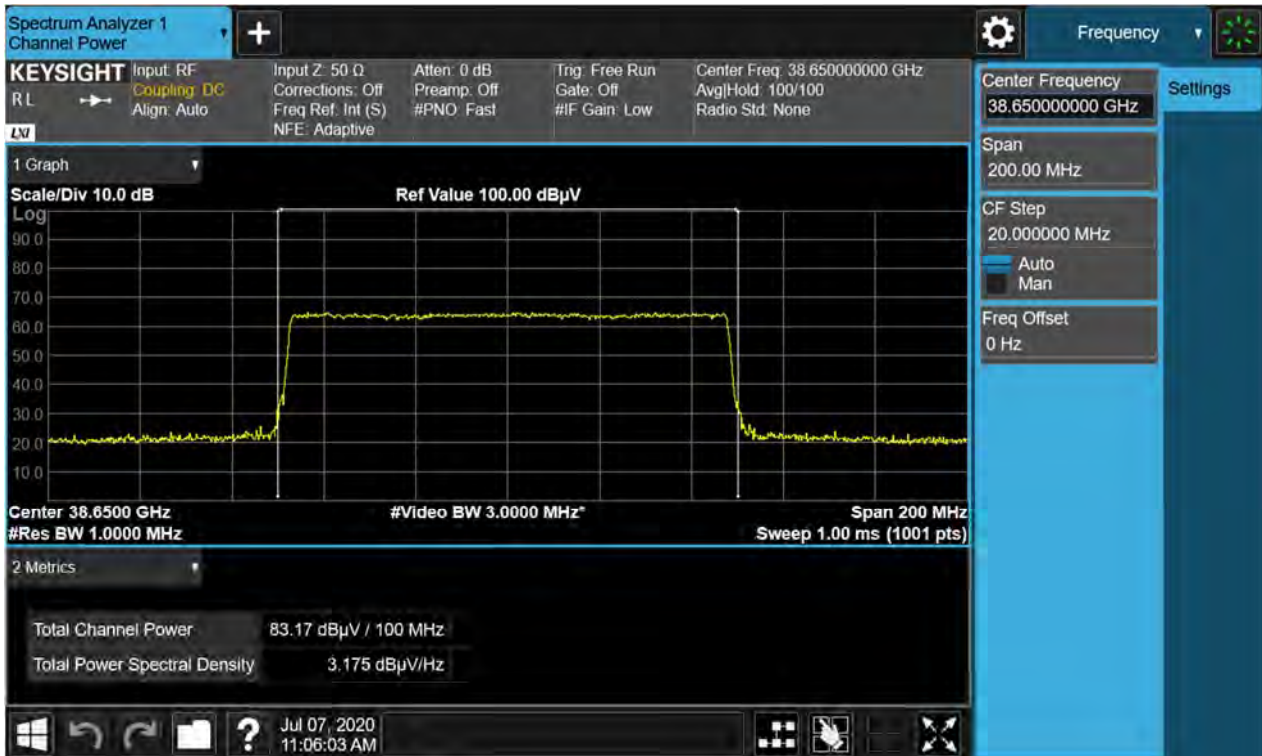

Antenna B / 1cc + 1cc / QPSK / Low / Non-Contiguous

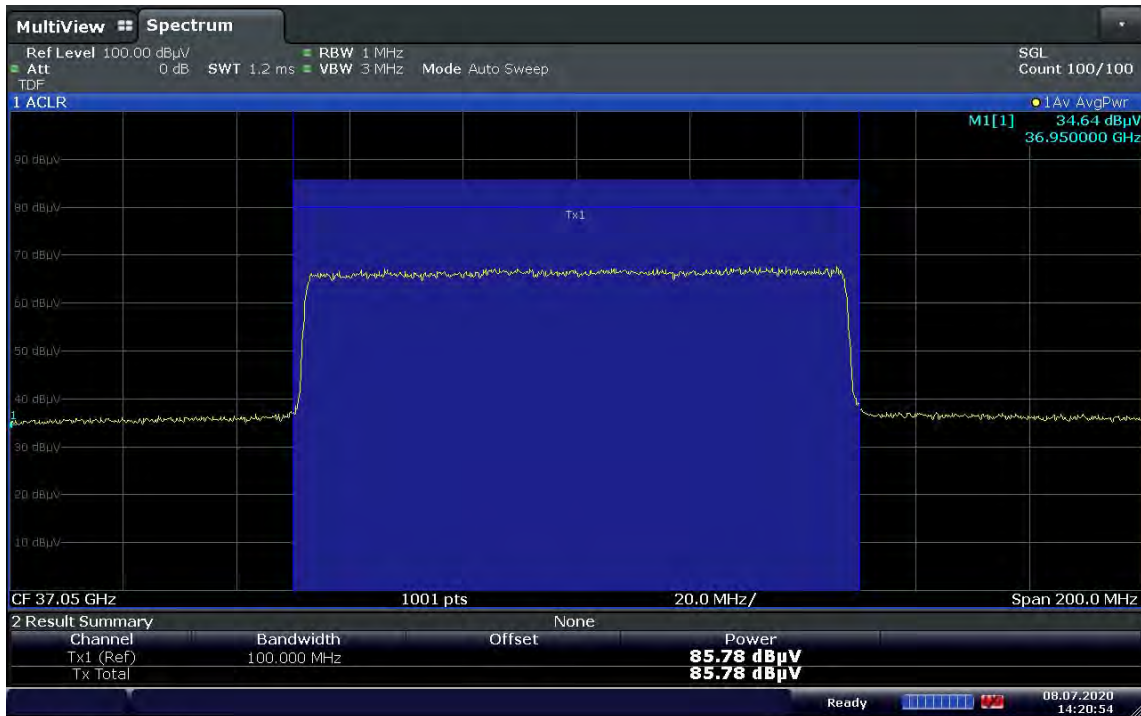

14:20:55 08.07.2020

Antenna B / 1cc + 1cc / 64QAM / Low / Non-Contiguous

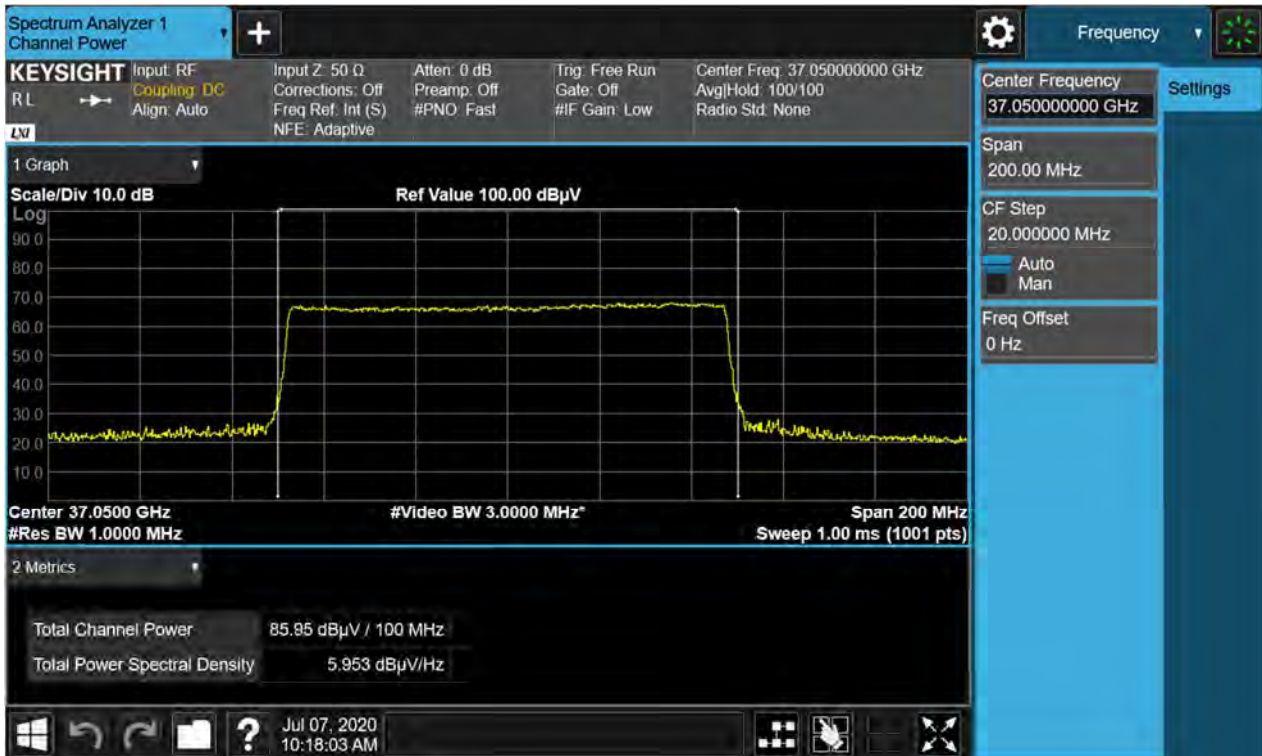

Antenna B / 1cc + 1cc / QPSK / Middle / Non-Contiguous

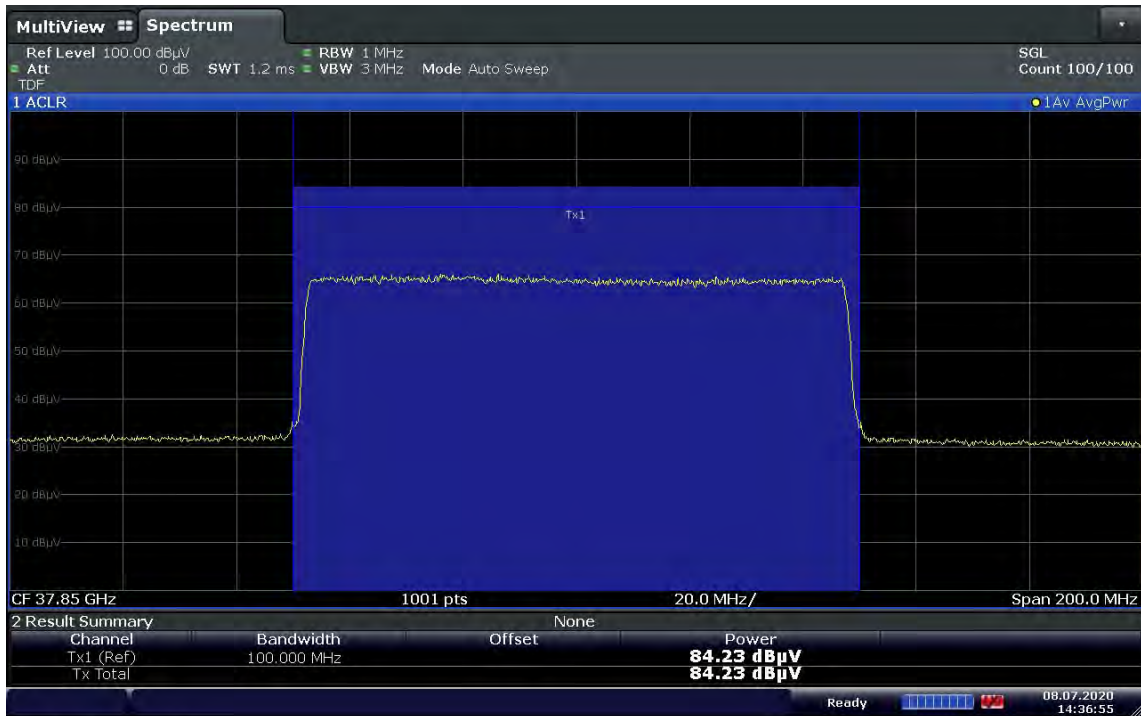

14:36:55 08.07.2020

Antenna B / 1cc + 1cc / 64QAM / Middle / Non-Contiguous

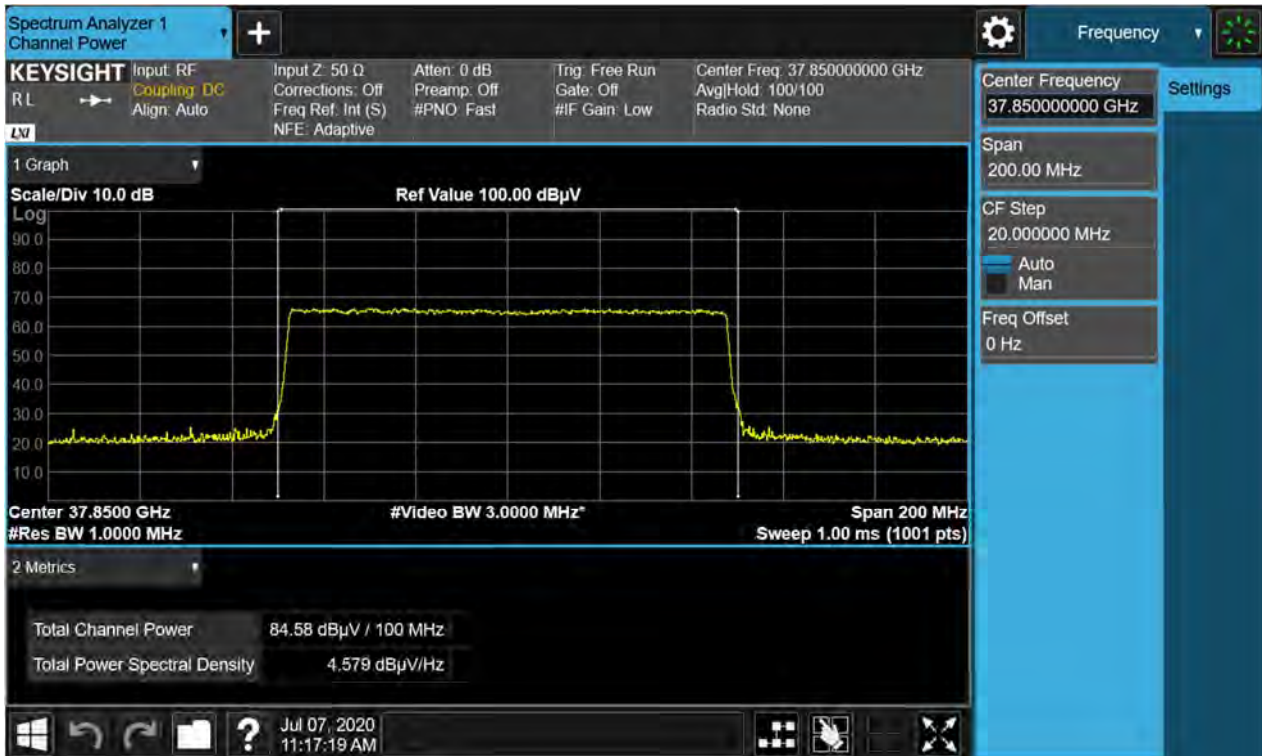

Antenna B / 1cc + 1cc / QPSK / High / Non-Contiguous

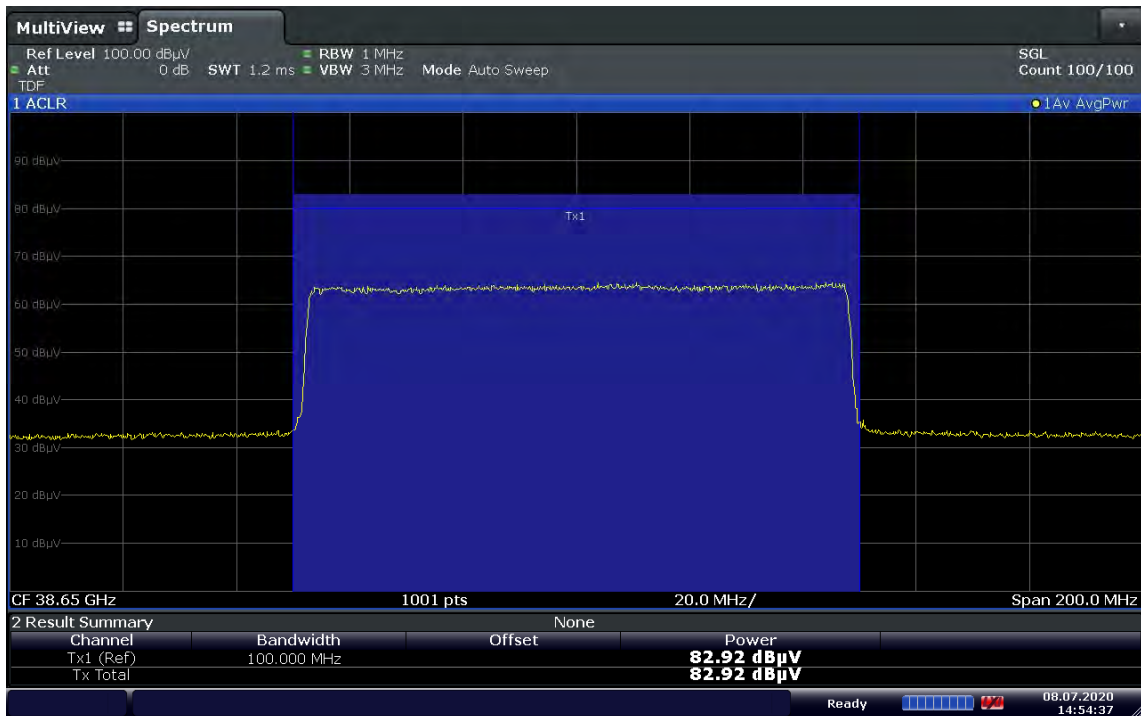

14:54:38 08.07.2020

Antenna B / 1cc + 1cc / 64QAM / High / Non-Contiguous



5.3. CONDUCTED OUTPUT POWER

FCC Rules

Test Requirements:

§ 2.1046 Measurements required: RF power output.

(a) For transmitters other than single sideband, independent sideband and controlled carrier radiotelephone, power output shall be measured at the RF output terminals when the transmitter is adjusted in accordance with the tune-up procedure to give the values of current and voltage on the circuit elements specified in § 2.1033(c)(8). The electrical characteristics of the radio frequency load attached to the output terminals when this test is made shall be stated.

(b) For single sideband, independent sideband, and single channel, controlled carrier radiotelephone transmitters the procedure specified in paragraph (a) of this section shall be employed and, in addition, the transmitter shall be modulated during the test as specified and applicable in § 2.1046 (b) (1-5). In all tests, the input level of the modulating signal shall be such as to develop rated peak envelope power or carrier power, as appropriate, for the transmitter.

(c) For measurements conducted pursuant to paragraphs (a) and (b) of this section, all calculations and methods used by the applicant for determining carrier power or peak envelope power, as appropriate, on the basis of measured power in the radio frequency load attached to the transmitter output terminals shall be shown. Under the test conditions specified, no components of the emission spectrum shall exceed the limits specified in the applicable rule parts as necessary for meeting occupied bandwidth or emission limitations.

Test Procedures:

The measurement is performed in accordance with Section 5.2.4.4.2 of ANSI C63.26.

- a) Set span to $2 \times$ to $3 \times$ the OBW.
- b) Set RBW = 1% to 5% of the OBW.
- c) Set VBW $\geq 3 \times$ RBW.
- d) Set number of measurement points in sweep $\geq 2 \times$ span / RBW.
- e) Sweep time:
 - 1) Set = auto-couple, or
 - 2) Set $\geq [10 \times (\text{number of points in sweep}) \times (\text{transmission symbol period})]$ for single sweep (automation-compatible) measurement.
- f) Detector = power averaging (rms).
- g) Set sweep trigger to "free run."
- h) Trace average at least 100 traces in power averaging (rms) mode if sweep is set to auto-couple. To accurately determine the average power over the on and off time of the transmitter, it can be necessary to increase the number of traces to be averaged above 100, or if using a manually configured sweep time, increase the sweep time.
- i) Compute power by integrating the spectrum across the OBW of the signal using the instrument's band or channel power measurement function with band/channel limits set equal to the OBW band edges. If the instrument does not have a band or channel power function, sum the spectrum levels (in linear power units) at intervals equal to the RBW extending across the entire OBW of the spectrum.

j) Add $10 \log (1/\text{duty cycle})$ to the measured power level to compute the average power during continuous transmission.

Note:

- 1) Basic test conditions are same as EIRP test on page 24.
- 2) Same 400 MHz bandwidth applies for 1cc and 4 cc.
- 3) Final conducted power is calculated as follows

$$\text{Conducted Power (dBm)} = \text{EIRP (dBm)} - \text{Antenna Gain (dBi)}$$

- 4) Antenna Gain of the above formula was applied from actual measurement data of the radiation pattern document.
- 5) Sample calculation

Antenna A, 1cc, Low, QPSK:

Contiguous

$$\begin{aligned} &90.87 \text{ dB}\mu\text{V (measured)} + 9.54(\text{distance}) - 104.77 + 49.26(\text{AFCL}) + 1.301 (\text{Duty}) - 24.80 (\text{Ant. gain}) \\ &= 21.41 \text{ dBm (Final conducted output power)} \end{aligned}$$

Non-Contiguous

$$\begin{aligned} &89.77 \text{ dB}\mu\text{V (measured)} + 9.54(\text{distance}) - 104.77 + 49.28(\text{AFCL}) + 1.301 (\text{Duty}) - 24.90 (\text{Ant. gain}) \\ &= 20.22 \text{ dBm (Final conducted output power)} \end{aligned}$$

Contiguous

Total Output Power (1cc, Low, QPKS):

Conversion dBm to mW (Antenna A)

$$10^{(21.41 \text{ dBm} / 10)} = 138.21 \text{ mW}$$

Sum each antenna power

$$138.21 \text{ mW (Ant.A)} + 136.02 \text{ mW (Ant.B)} = 274.22 \text{ mW}$$

Conversion mW to dBm

$$10 \text{ LOG } (274.22 \text{ mW}) = 24.38 \text{ dBm}$$

Test Results:
1. Contiguous
Tabular Data of Conducted Output Power

Ant.	Ant.	CC	Achannel	Frequency (GHz)	Mod.	Measured Level (dBuV)	EIRP	Ant. Gain	Result
	Angle						(dBm)	(dBi)	(dBm)
A	135°	8	Low	37.39986	64QAM	90.87	46.21	24.80	21.41
			Middle	38.49990		88.87	45.55	24.90	20.65
			High	39.60010		87.69	47.69	25.00	22.69
B	45°		Low	37.39986		90.81	46.14	24.80	21.34
			Middle	38.49990		89.39	46.06	24.90	21.16
			High	39.60010		87.71	47.71	25.00	22.71

Tabular Data of Conducted SUM Output Power

Antenna	CC	Channel	Mod.	Ant. A (dBm)	Ant. B (dBm)	Result (dBm)
A+B	8	Low	64QAM	21.41	21.34	24.38
		Middle		20.65	21.16	23.92
		High		22.69	22.71	25.71

2. Non-Contiguous

Ant.	Ant.	CC	Channel	Center Frequency (GHz)	Mod.	Measured Level (dBuV)	EIRP (dBm)	Ant. Gain (dBi)	Result (dBm)
	Angle								
A	135°	1+1	Low	37.70000	64QAM	88.45	43.80	24.90	18.90
			Mid	38.50000		86.97	43.64	24.90	18.74
			High	39.30000		85.07	44.30	25.00	19.30
B	45°		Low	37.70000		88.06	43.42	24.90	18.52
			Mid	38.50000		86.74	43.42	24.90	18.52
			High	39.30000		85.39	44.62	25.00	19.62

Tabular Data of Conducted SUM Output Power

Antenna	CC	Channel	Mod.	Ant. A (dBm)	Ant. B (dBm)	Result (dBm)
A+B	1+1	Low	64QAM	18.90	18.52	21.72
		Middle		18.74	18.52	21.64
		High		19.30	19.62	22.47

Plot Data of Conducted Output Power

Antenna A / 8cc / 64QAM / Low / Contiguous



Antenna A / 8cc / 64QAM / Middle / Contiguous



Antenna A / 8cc / 64QAM / High / Contiguous



Antenna B / 8cc / 64QAM / Low / Contiguous



Antenna B / 8cc / 64QAM / Middle / Contiguous



Antenna B / 8cc / 64QAM / High / Contiguous



Antenna A / 1cc + 1cc / 64QAM / Low / Non-Contiguous

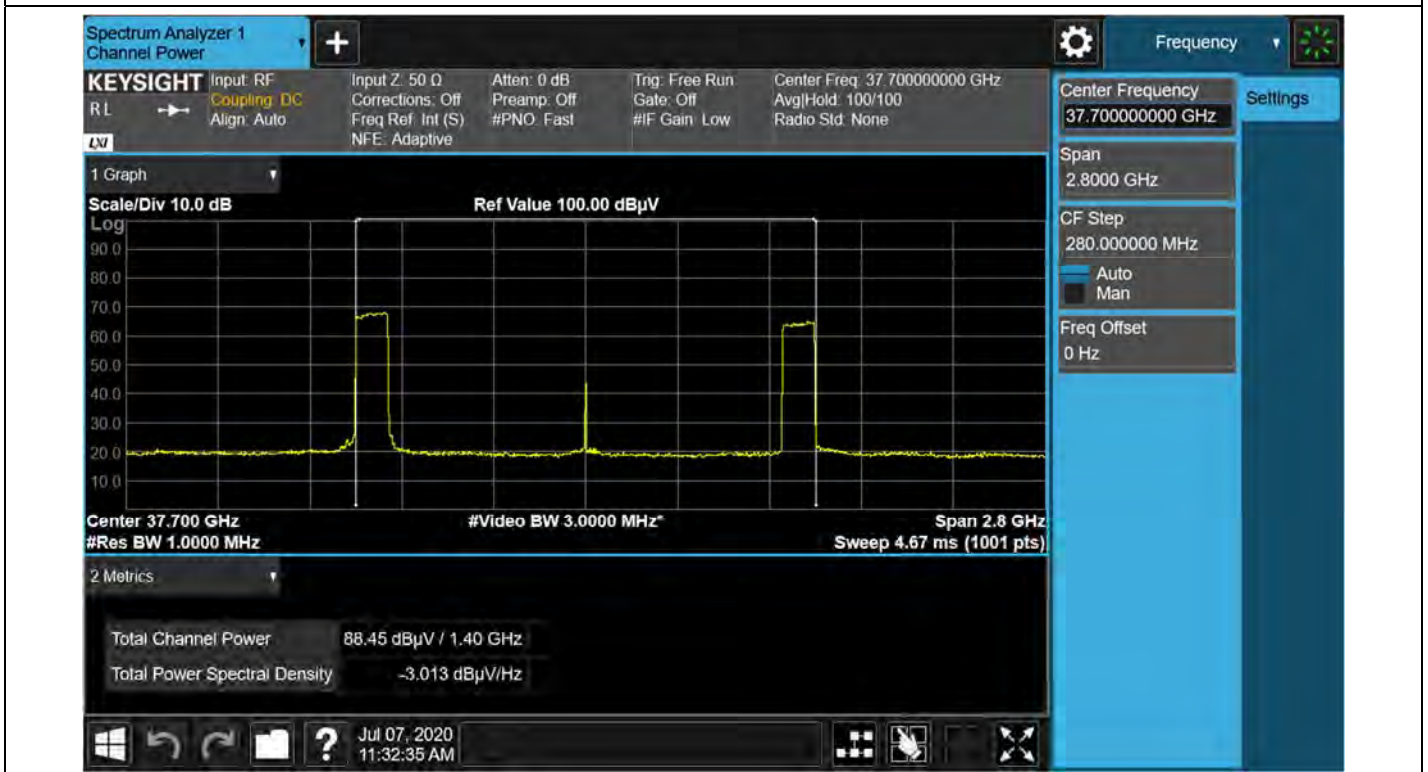

Antenna A / 1cc + 1cc / 64QAM / Middle / Non-Contiguous

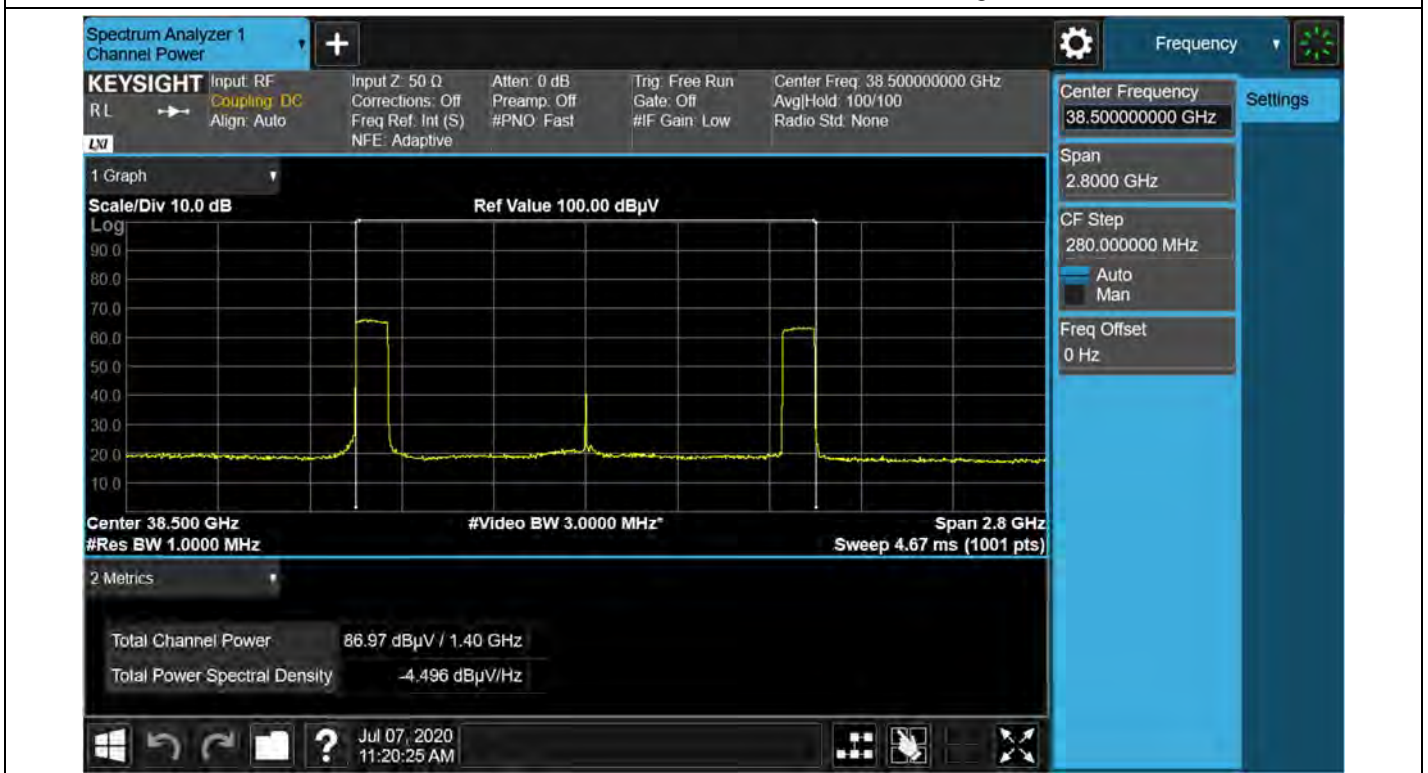

Antenna A / 1cc + 1cc / 64QAM / High / Non-Contiguous

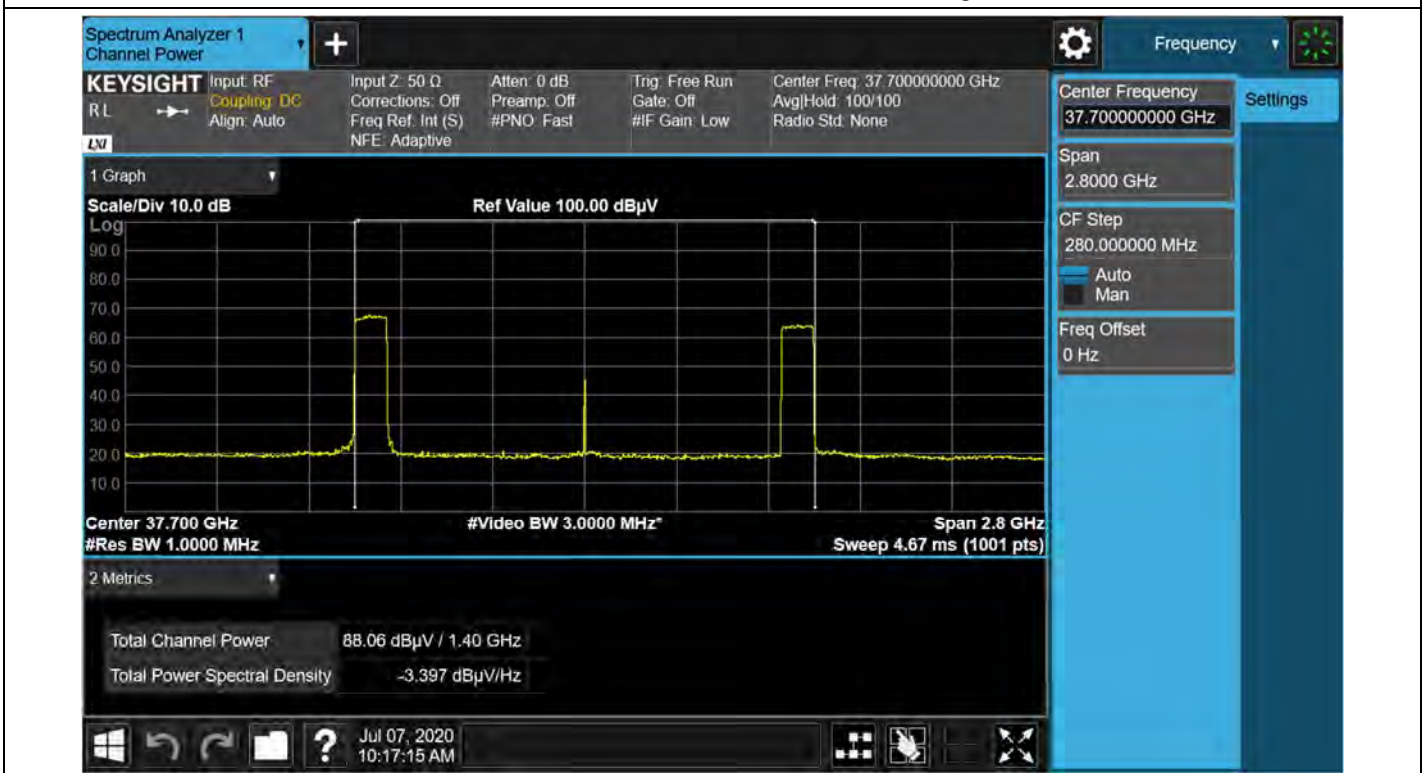
Antenna B / 1cc + 1cc / 64QAM / Low / Non-Contiguous

Antenna B / 1cc + 1cc / 64QAM / Middle / Non-Contiguous



Antenna B / 1cc + 1cc / 64QAM / High / Non-Contiguous



5.4. BAND EDGE

FCC Rules

Test Requirements:

§ 2.1051 Measurements required: Spurious emissions at antenna terminals.

The radio frequency voltage or powers generated within the equipment and appearing on a spurious frequency shall be checked at the equipment output terminals when properly loaded with a suitable artificial antenna. Curves or equivalent data shall show the magnitude of each harmonic and other spurious emission that can be detected when the equipment is operated under the conditions specified in § 2.1049 as appropriate. The magnitude of spurious emissions which are attenuated more than 20 dB below the permissible value need not be specified.

§ 30.203 Emission limits.

- (a) The conductive power or the total radiated power of any emission outside a licensee's frequency block shall be -13 dBm/MHz or lower. However, in the bands immediately outside and adjacent to the licensee's frequency block, having a bandwidth equal to 10 percent of the channel bandwidth, the conductive power or the total radiated power of any emission shall be -5 dBm/MHz or lower.
- (b)(1) Compliance with this provision is based on the use of measurement instrumentation employing a resolution bandwidth of 1 megahertz or greater.
- (2) When measuring the emission limits, the nominal carrier frequency shall be adjusted as close to the licensee's frequency block edges as the design permits.
- (3) The measurements of emission power can be expressed in peak or average values.

Test Procedures:

The measurement is performed in accordance with Section 5.7.3 of ANSI C63.26.

5.7.3 Out-of-band unwanted emissions measurements

- a) Set the spectrum analyzer center frequency to the block, band, or channel edge frequency.
- b) Set the span wide enough to capture the fundamental emission closest to the authorized block or band edge, and to include all modulation products that spill into the immediately adjacent frequency band. In some cases, it may be possible to set the center frequency and span so as to encompass the fundamental emission and the unwanted out-of-band (band-edge) emissions on either side of the authorized block, band, or channel. This can be accomplished with a single (slow) sweep, if adequate overload protection and sufficient dynamic range can be maintained.
- c) Set the number of points in sweep $\geq 2 \times \text{span} / \text{RBW}$.
- d) Sweep time should be auto for peak detection. For rms detection the sweep time should be set as follows:
 - 1), 2) Omitted
 - 3) If the device cannot be configured to transmit continuously (duty cycle $< 98\%$) and a free running sweep must be used, set the sweep time so that the averaging is performed over multiple on/off cycles by setting the sweep time $> (\text{number of points in sweep}) \times (\text{transmitter period})$ (i.e., the transmit on-time + the off-time). The spectrum analyzer readings shall subsequently be corrected by $[10 \log (1/\text{duty cycle})]$. This assumes that the transmission period and duty cycle is relatively

constant (duty cycle variation $\leq \pm 2\%$).

4) Omitted

e) The test report shall include the plots of the measuring instrument display and the measured data.

f) See Annex I for example emission mask plots.

Note:

- 1) Basic test conditions are same as EIRP test on page 24.
- 2) In the band edge test of antenna A, path A, B are individually operated and measured at the maximum emission position of antenna A, and the respective measurement results are summed.
- 3) For measurement of antenna B repeat 2) at the maximum emission position of antenna B.
- 4) Band edge value is calculated as follows.

$$\text{Low Band Edge} = \text{Measured Value} + 20\log(D) - 104.77 + \text{AFCL} + \text{Duty} - \text{Ant. Gain}$$

$$\text{High Band Edge} = \text{Measured Value (EIRP (dBm)} + 107) + 20\log(D) - 104.77 + \text{AFCL} + \text{Duty} - \text{Ant. Gain}$$

- 5) Antenna Gain of the above formula was applied from actual measurement data of the radiation pattern document.
- 6) Sample calculation

Maximum Antenna A, 1cc, Low, QPSK:

Contiguous

Antenna A

$$26.899 \text{ dB}\mu\text{V (measured)} + 9.54(\text{distance}) - 104.77 + 49.26(\text{AFCL}) + 1.301 (\text{Duty}) \\ = -17.53 \text{ dBm (Antenna A Edge)}$$

Total edge result

Conversion and sum

$$0.017660 \text{ mW (Ant.A)} + 0.009419 \text{ mW (Ant.B)} = 0.027079 \text{ mW}$$

Conversion mW to dBm

$$10\text{LOG} (0.027079 \text{ mW}) - 24.80 (\text{Antenna gain}) = -40.47 \text{ dBm}$$

Sum each antenna power

$$(-40.47 \text{ dBm}) (\text{Ant.A}) + (-35.56 \text{ dBm}) (\text{Ant.B}) = -34.34 \text{ dBm}$$

Test Results:
1. Contiguous
Tabular Data of Band Edge

Pos.	Ant.	CC	Edge	Mod.	Ant	Measured Level (dBuV)	EIRP (dBm)	Ant Gain (dB)	Result
	Angle								(dBm)
MAX Ant. A	135°	8	Low	64QAM	A	26.899	-17.53	24.80	-42.33
					B	24.170	-20.26		-45.06
			High		A	32.45	-7.76	24.90	-32.66
					B	32.52	-7.69		-32.59
MAX Ant. B	45°		Low		A	27.253	-17.17	24.80	-41.97
					B	32.546	-11.88		-36.68
			High		A	32.51	-7.70	24.90	-32.60
					B	32.72	-7.49		-32.39

MIMO Data of Band Edge

Antenna	cc	Edge	Modulation	Result (dBm)
A+B	8	Low	64QAM	-34.34
		High		-26.54

2. Non-Contiguous

Pos.	Ant.	cc	Edge	Mod.	Ant	Measured Level (dBuV)	EIRP (dBm)	Ant Gain (dB)	Result
	Angle								(dBm)
MAX Ant. A	135°	1+1	Low	64QAM	A	31.398	-13.03	24.80	-37.83
					B	24.703	-19.72		-44.52
			High		A	34.21	-6.00	24.90	-30.90
					B	32.25	-7.96		-32.86
MAX Ant. B	45°		Low		A	25.754	-18.67	24.80	-43.47
					B	29.991	-14.44		-39.24
			High		A	32.76	-7.45	24.90	-32.35
					B	34.34	-5.87		-30.77

MIMO Data of Band Edge

Antenna	cc	Edge	Modulation	Result (dBm)
A+B	1+1	Low	64QAM	-34.38
		High		-25.60

Plot data of Band Edge

MAX Ant. A Position / 8cc / Low / 64QAM / Ant. A / Contiguous



MAX Ant. A Position / 8cc / Low / 64QAM / Ant. B / Contiguous



MAX Ant. A Position / 8cc / High / 64QAM / Ant. A / Contiguous

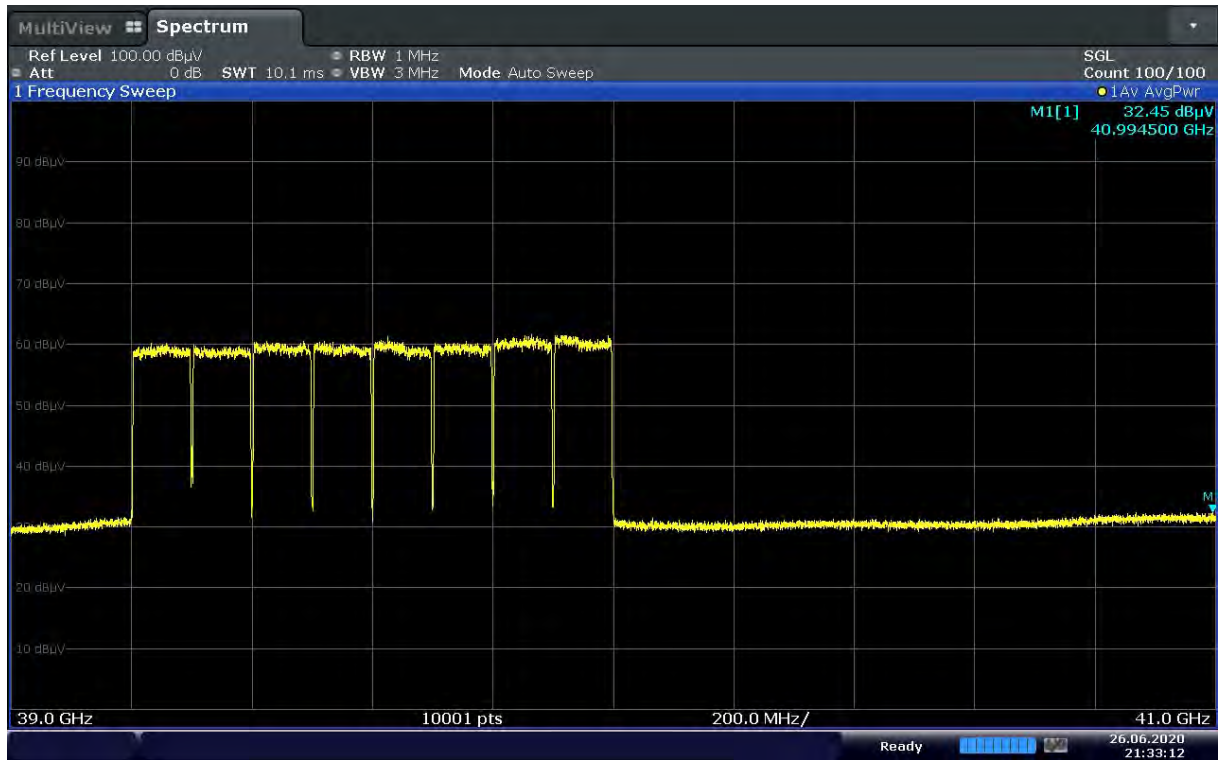

MAX Ant. A Position / 8cc / High / 64QAM / Ant. B / Contiguous

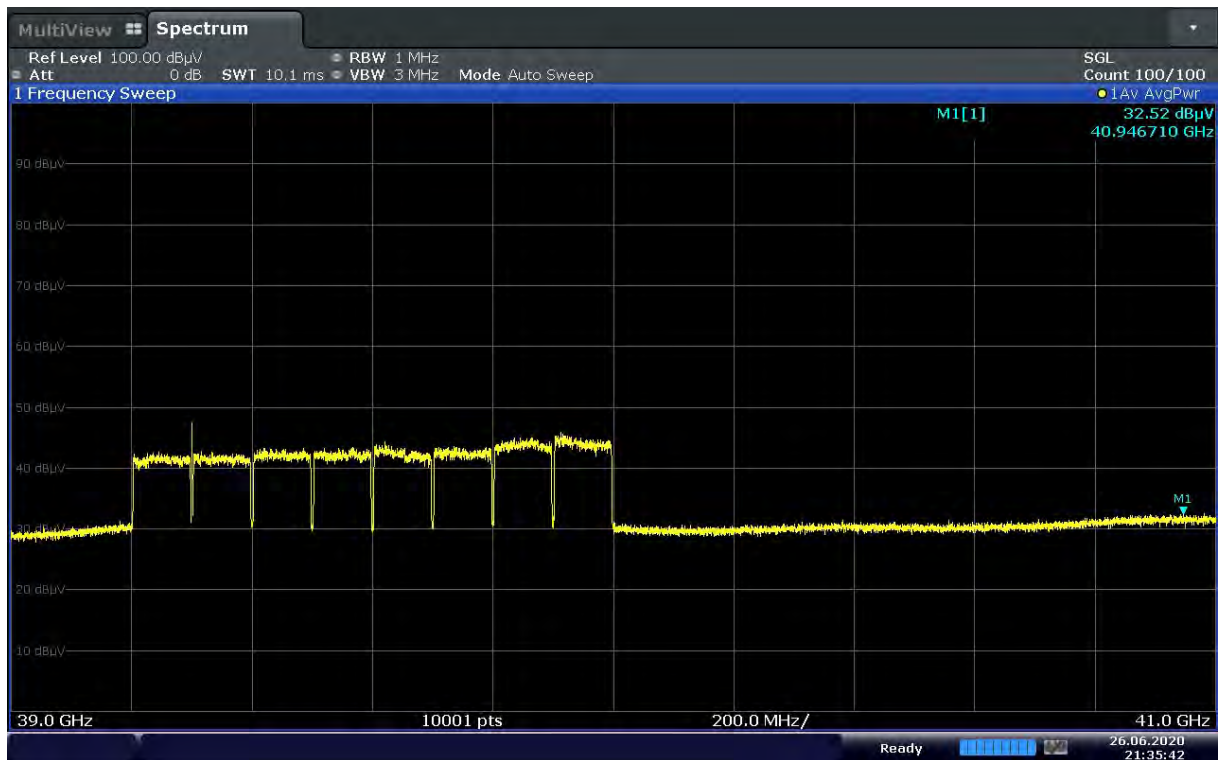

MAX Ant. B Position / 8cc / Low / 64QAM / Ant. A / Contiguous

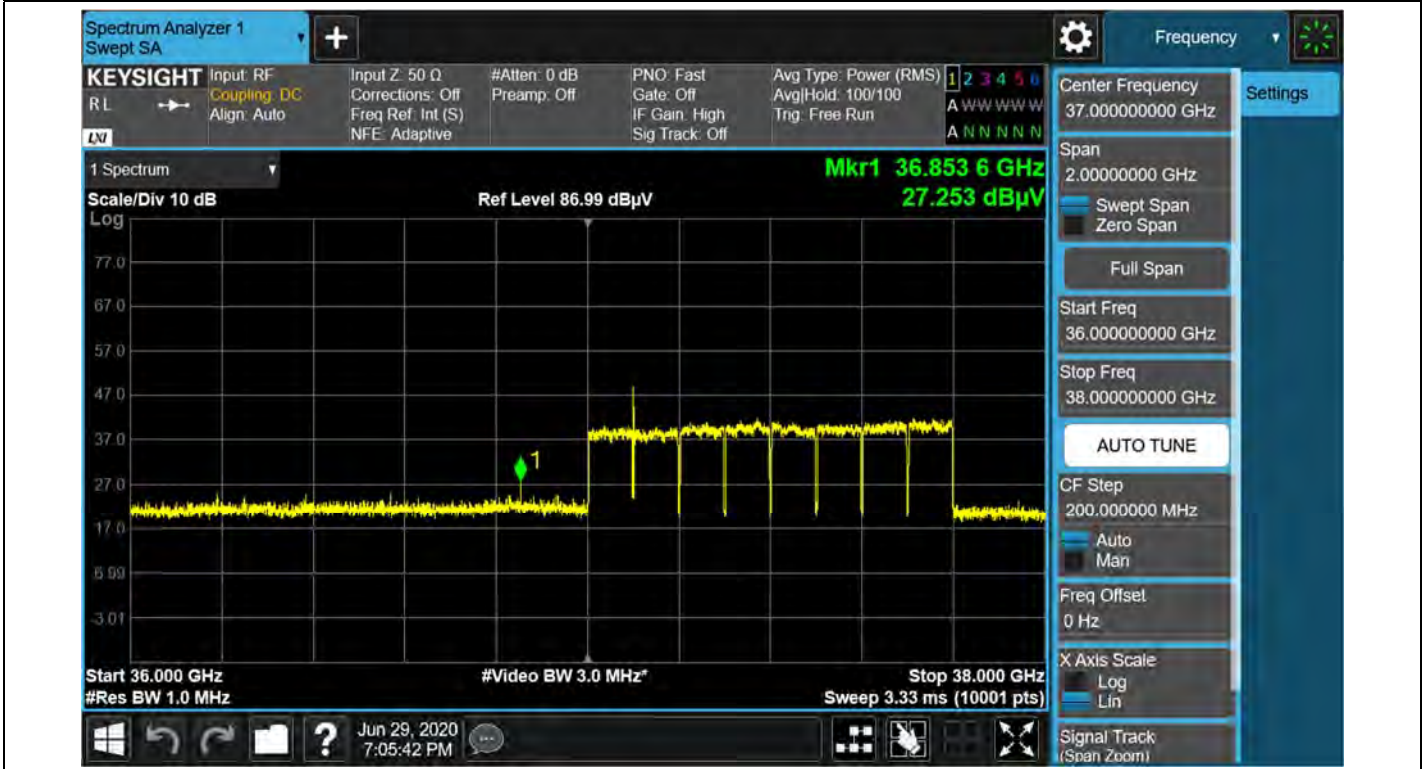

MAX Ant. B Position / 8cc / Low / 64QAM / Ant. B / Contiguous



MAX Ant. B Position / 8cc / High / 64QAM / Ant. A / Contiguous

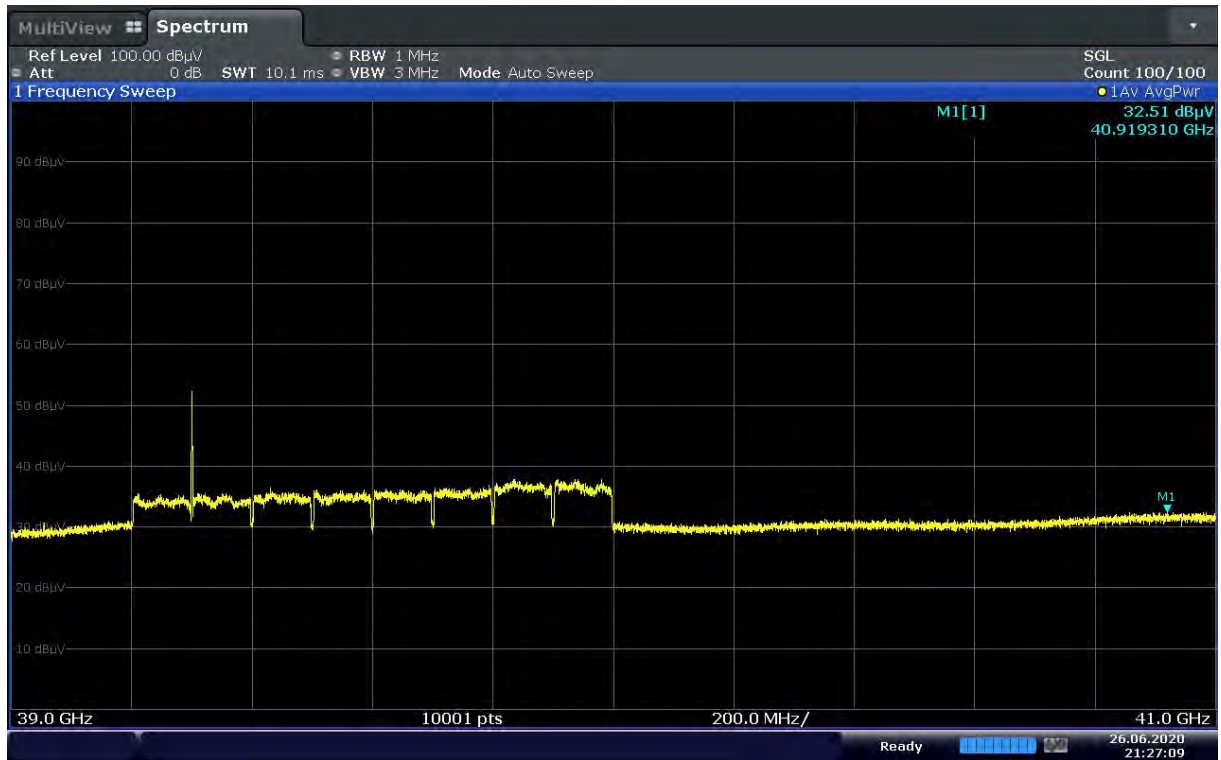

MAX Ant. B Position / 8cc / High / 64QAM / Ant. B / Contiguous

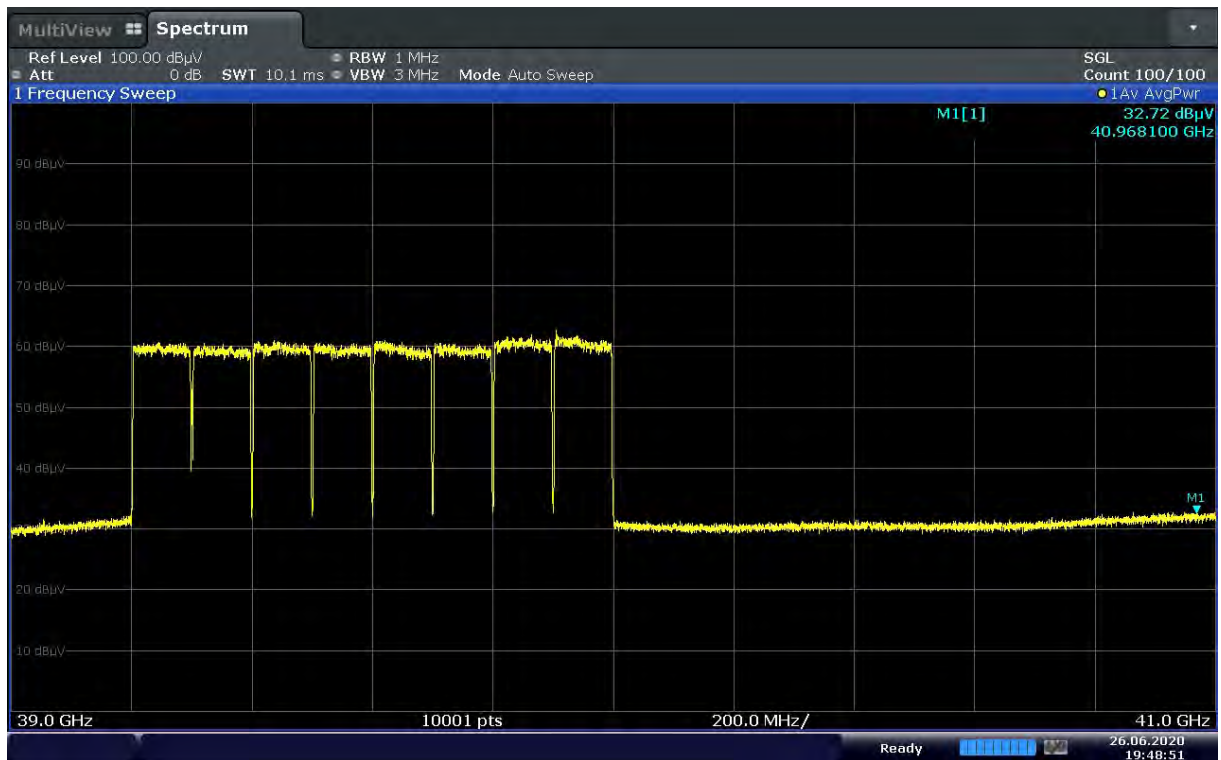

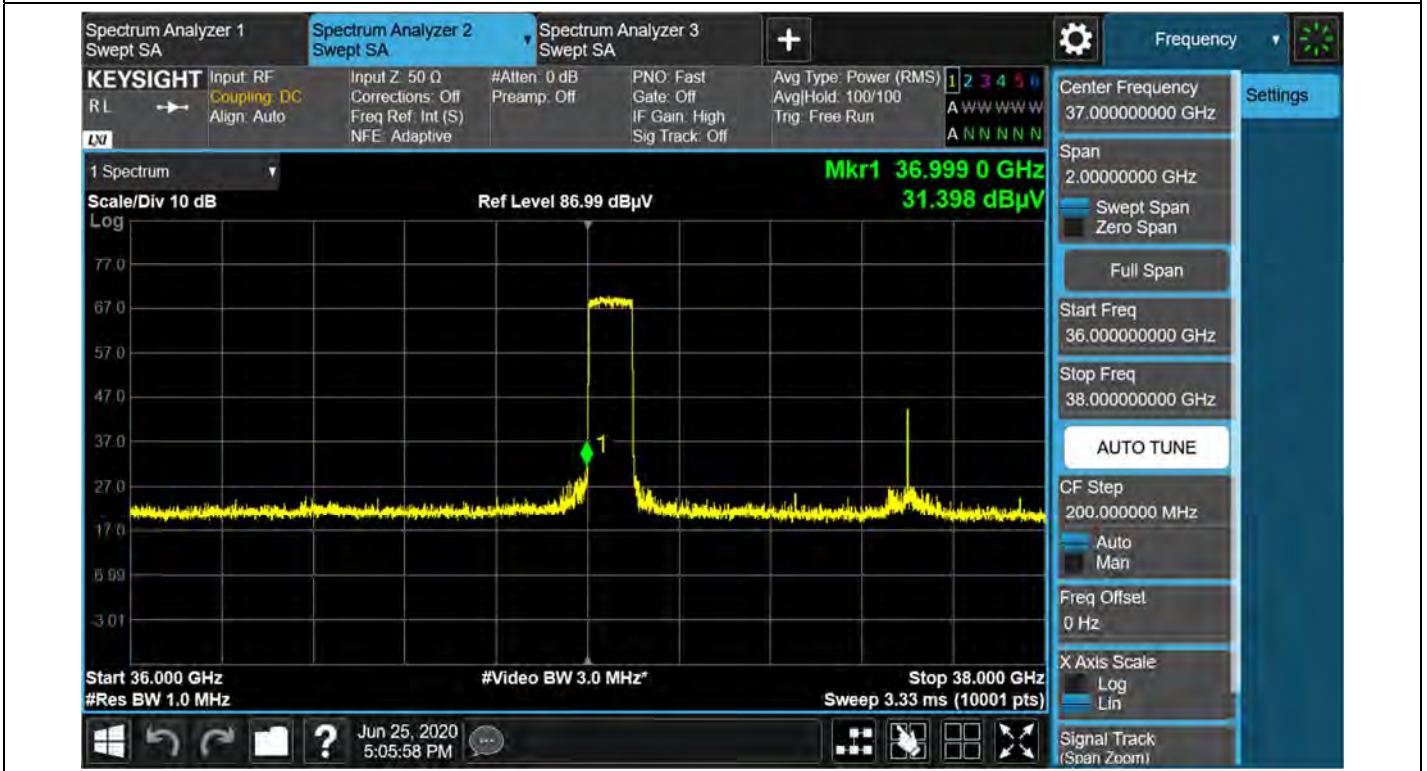
MAX Ant. A Position / 1cc + 1cc / Low / 64QAM / Ant. A / Non-Contiguous

MAX Ant. A Position / 1cc + 1cc / Low / 64QAM / Ant. B / Non-Contiguous

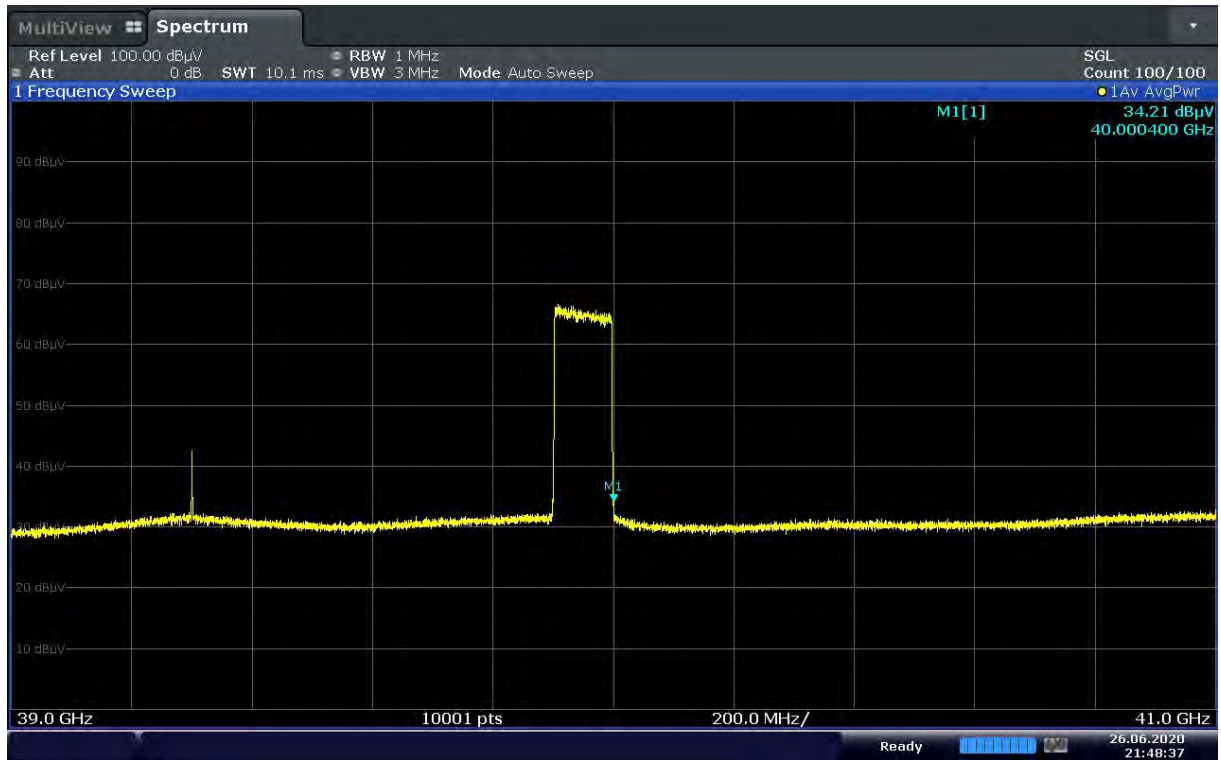
MAX Ant. A Position / 1cc + 1cc / High / 64QAM / Ant. A / Non-Contiguous

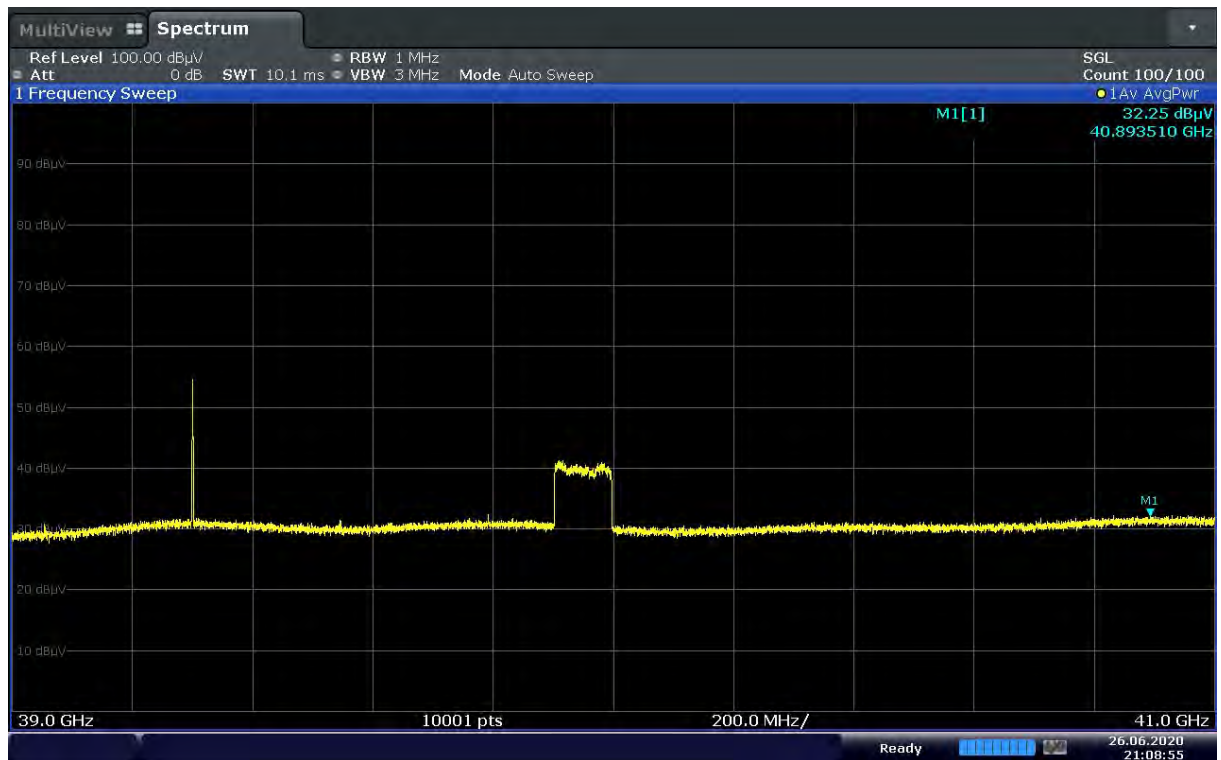

MAX Ant. A Position / 1cc + 1cc / High / 64QAM / Ant. B / Non-Contiguous

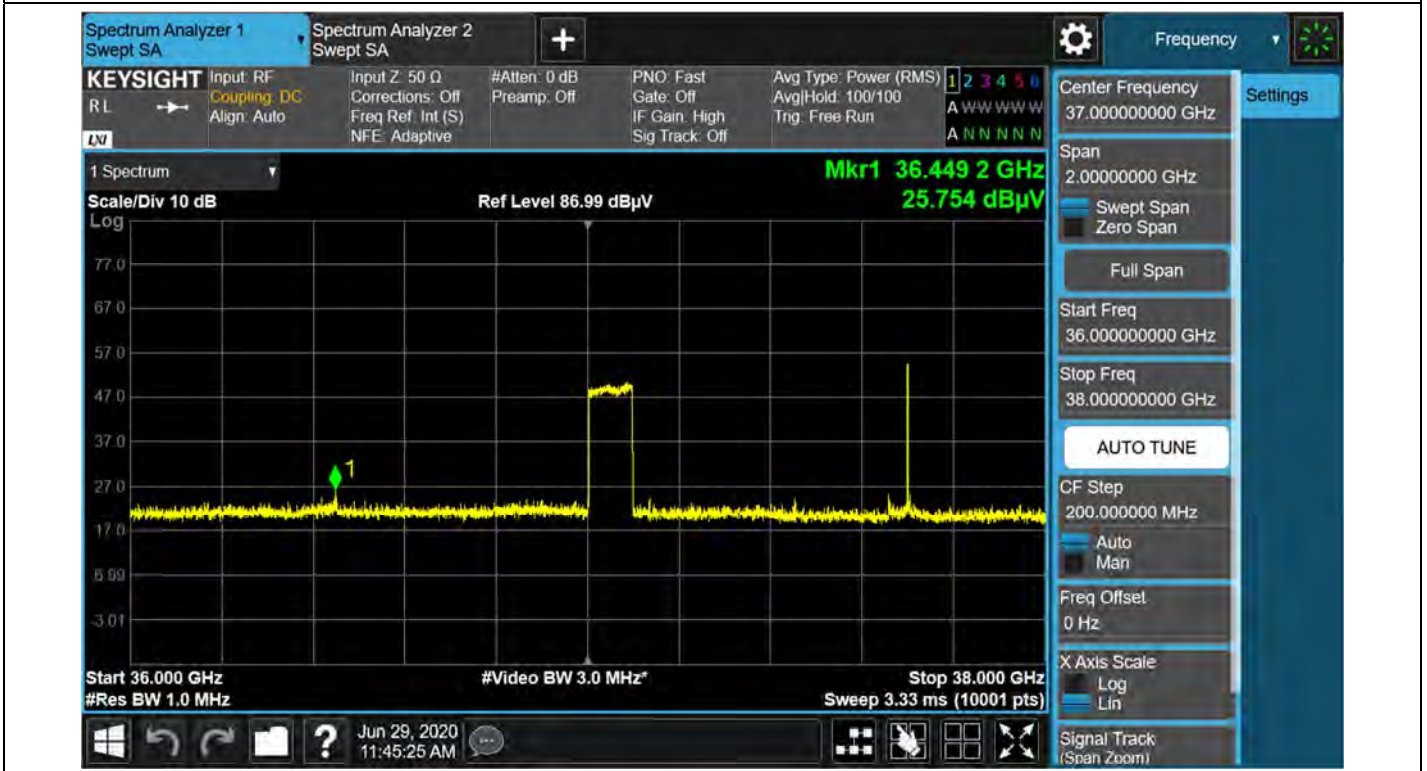
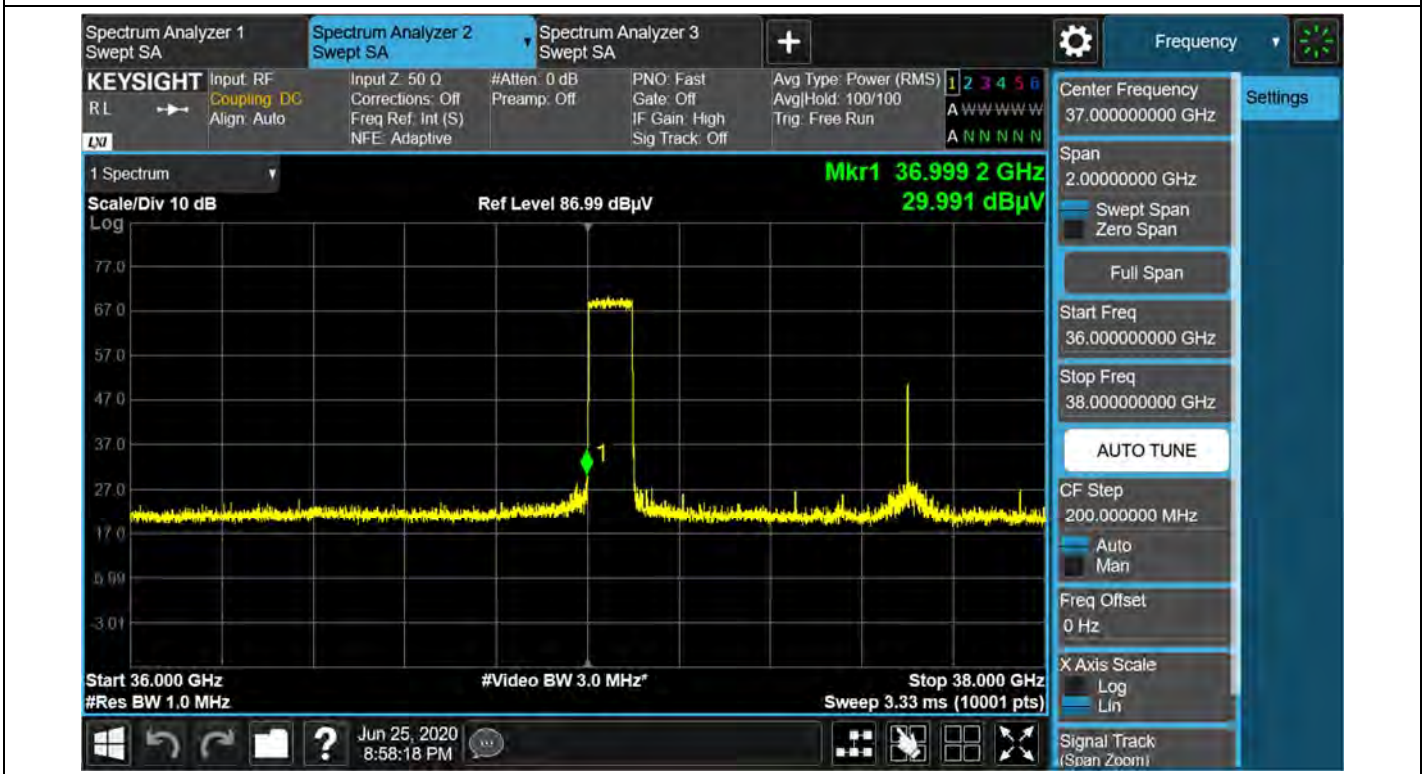

MAX Ant. B Position / 1cc + 1cc / Low / 64QAM / Ant. A / Non-Contiguous

MAX Ant. B Position / 1cc + 1cc / Low / 64QAM / Ant. B / Non-Contiguous

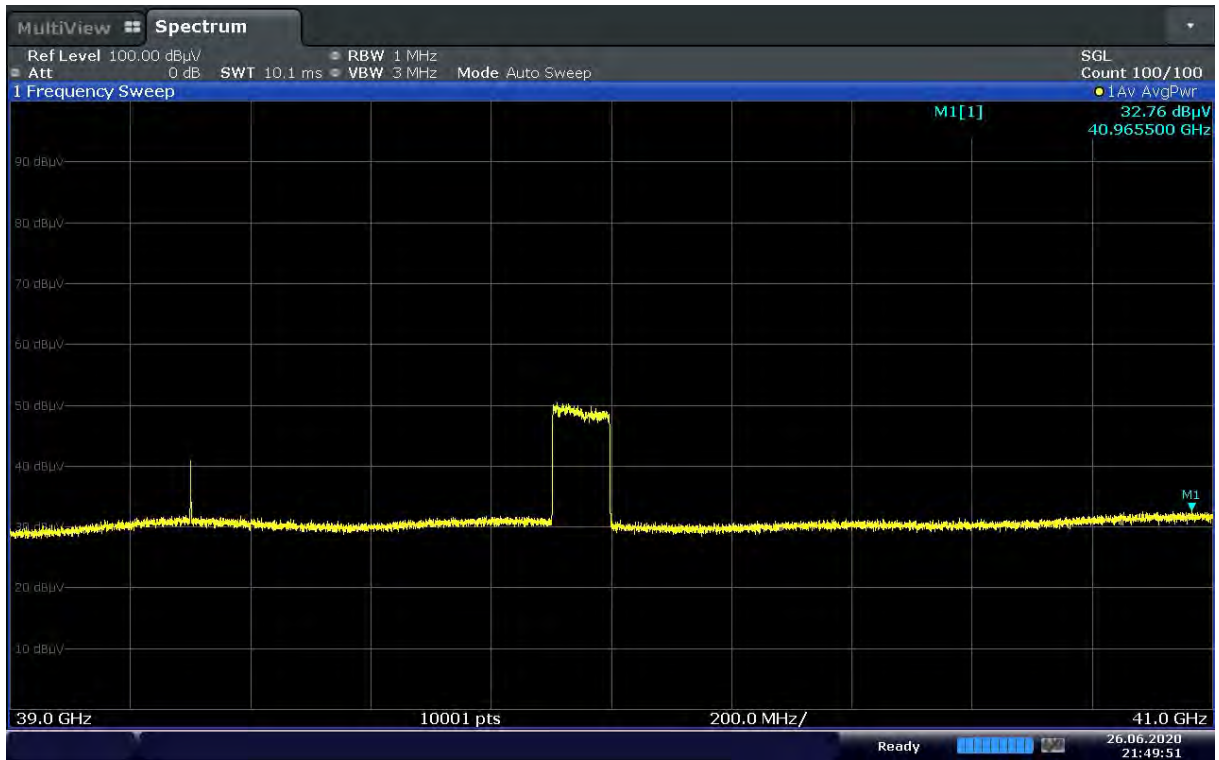
MAX Ant. B Position / 1cc + 1cc / High / 64QAM / Ant. A / Non-Contiguous

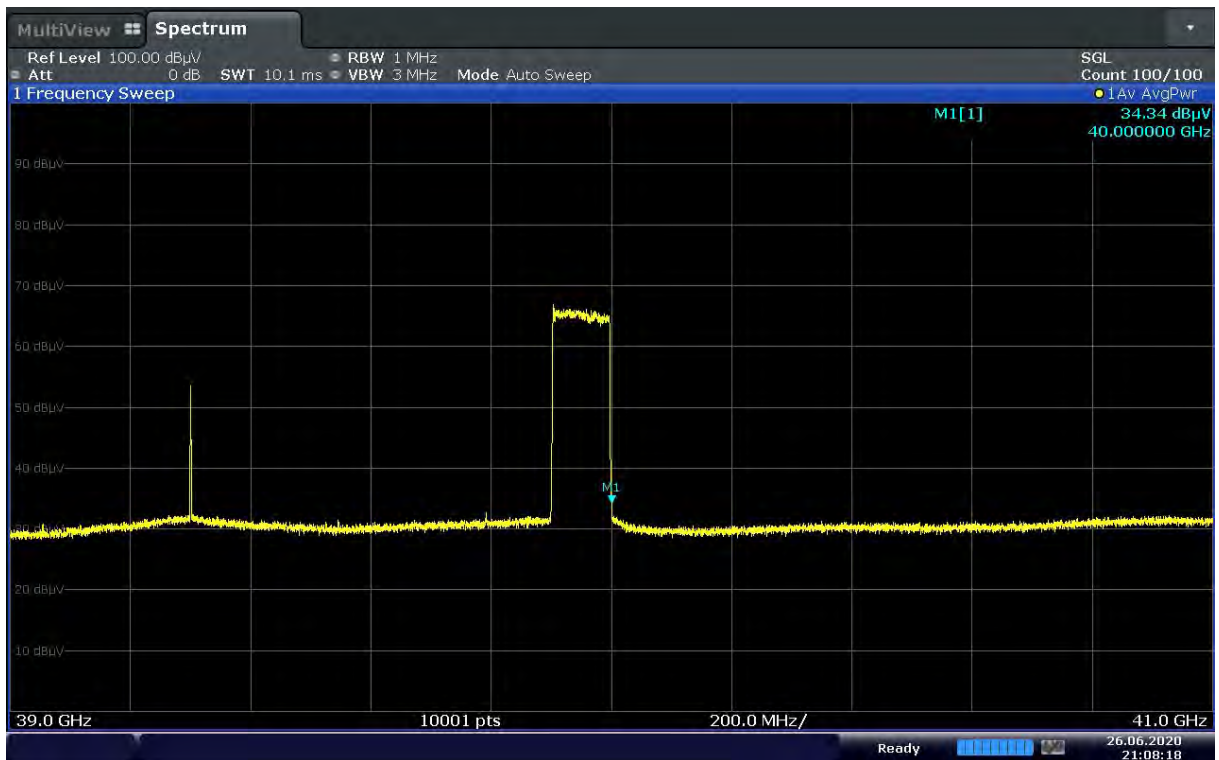

MAX Ant. B Position / 1cc + 1cc / High / 64QAM / Ant. B / Non-Contiguous



5.5. RADIATED SPURIOUS EMISSIONS

FCC Rules

Test Requirements:

§ 2.1051 Measurements required: Spurious emissions at antenna terminals.

The radio frequency voltage or powers generated within the equipment and appearing on a spurious frequency shall be checked at the equipment output terminals when properly loaded with a suitable artificial antenna. Curves or equivalent data shall show the magnitude of each harmonic and other spurious emission that can be detected when the equipment is operated under the conditions specified in § 2.1049 as appropriate. The magnitude of spurious emissions which are attenuated more than 20 dB below the permissible value need not be specified.

§ 30.203 Emission limits.

- (a) The conductive power or the total radiated power of any emission outside a licensee's frequency block shall be -13 dBm/MHz or lower. However, in the bands immediately outside and adjacent to the licensee's frequency block, having a bandwidth equal to 10 percent of the channel bandwidth, the conductive power or the total radiated power of any emission shall be -5 dBm/MHz or lower.
- (b)(1) Compliance with this provision is based on the use of measurement instrumentation employing a resolution bandwidth of 1 megahertz or greater.
- (2) When measuring the emission limits, the nominal carrier frequency shall be adjusted as close to the licensee's frequency block edges as the design permits.
- (3) The measurements of emission power can be expressed in peak or average values.

EIRP Test Procedures:

The measurement is performed in accordance with Section 5.7.4 of ANSI C63.26.

5.7.4 Spurious unwanted emission measurements

- a) Set the spectrum analyzer start frequency to the lowest frequency generated by the EUT, without going below 9 kHz, and the stop frequency to the lower frequency covered by the measurements previously performed in 5.7.3. As an alternative, the stop frequency can be set to the value specified in 5.1.1, depending on the EUT operating range, if the resulting plot can clearly demonstrate compliance for all frequencies not addressed by the out-of-band emissions measurements performed as per 5.7.3.
- b) When using an average power (rms) detector, ensure that the number of points in the sweep $\geq 2 \times (\text{span} / \text{RBW})$. This may require that the measurement range defined by the start and stop frequencies be subdivided, depending on the spectrum analyzer capabilities. This requirement does not apply to peak-detected power measurements. When average power is specified by the applicable regulation, a peak-detector can be utilized for preliminary measurements to accommodate wider frequency spans. Any emissions found in the preliminary measurement to exceed the applicable limit(s) shall be further examined using a power averaging (rms) detector with the minimum number of measurement points as defined above.
- c) The sweep time should be set to auto-couple for performing peak-detector measurements. For measurements that use a power averaging (rms) detector, the sweep time shall be set as described for out-of-band emissions measurements in item d)

of 5.7.3.

- d) Identify and measure the highest spurious emission levels in each frequency range. It is not necessary to re-measure the out-of-band emissions as a part of this test. Record the frequencies and amplitudes corresponding to the measured emissions and capture the data plots.
- e) Repeat step b) through step d) for the upper spurious emission frequency range if not already captured by a wide span measurement performed as per the alternative provided in step a). The upper frequency for this measurement is defined in 5.1.1 as a function of the EUT operating range.
- f) Compare the results with the corresponding limit in the applicable regulation.
- g) The test report shall include the data plots of the measuring instrument display and the measured data.

TRP Test Procedures:

The measurement is performed in accordance with Section 4.4.3.3.2 of KDB 842590 v01 (2019-04).

- a) Align the EUT with a chosen xy-plane and the xz-plane of the antenna measurement coordinate system.
NOTE 1 For harmonics and spurious emission frequencies which are beamforming as identified in exploratory scan, it may be required to align the orthogonal cuts to include the peak based on exploratory scans.
- b) Measure the EUT dimensions, i.e., depth (d), width (w), and height (h); see Figure A.1 in Appendix A.
- c) Calculate the spherical and cylindrical diameters (D and D_{cyl}) using Equations (A.1) and (A.2) (see Appendix A).
- d) For the highest frequency (smallest wavelength) of the frequency band measured, calculate the reference angular steps $\Delta\theta_{ref}$ and $\Delta\phi_{ref}$ using Equations (A.3) and (A.4).
- e) Set the grid spatial sampling step $\Delta\theta \leq \Delta\theta_{ref}$ for the vertical angle and $\Delta\phi \leq \Delta\phi_{ref}$ for the horizontal cut.
- f) For each emission frequency, measure the EIRP (as a sum of two orthogonal polarizations) at each spatial sampling step on the selected grid.
- g) For each emission frequency, calculate the average EIRP for both the cuts separately, and then take the average of these two average values.
- h) Add 2 dB as a correction factor to the averaged value computed in step g).
- i) If the TRP limit is exceeded, a third orthogonal cut in the yz-plane and using the $\Delta\theta$ angular step, can be added. Now, calculate the average values in all three cuts separately, and then take the average value of these three average values.
- j) Add 1.5 dB as a correction factor to the averaged value computed in step i).
- k) Evaluate the pass/fail decision by comparing TRP from step h) or step j) against the applicable TRP limit.

Note:

- 1) Spurious emission test is performed up to 200 GHz frequency according to section 5.1.1 of ANSI C63.26 -2015.
- 2) Measurement distance is applied far field condition on page 8.
- 3) In case of 9 kHz to 30 MHz, the reading of emissions are attenuated more than 20 dB below the permissible limits or the field strength is too small to be measured.
- 4) Emissions in 35.5 GHz to 40 GHz(Low, Middle channel) or 42 GHz(High channel) band can be founded in section 5.1 through 5.4 of this report
- 5) We were performed the test in MIMO mode.
- 6) Test plot doesn't include any factors and all factors such as AFCL is calculated in tabular data.
- 7) In this test, AFCL factor consists of antenna factor, cable loss, mixer loss, amplifier gain and duty correction.
- 8) Emissions value is first converted by distance factor as follow.

$$\text{Converted value (dBm)} = \text{Measured Value (dBuV)} + 20 \text{ LOG}(D) - 104.77$$

- 9) Final spurious emissions result is calculated as follows.

$$\text{Spurious Emissions} = \text{Converted Value (dBm)} + \text{AFCL}$$

- 10) Refer to conducted output power test, spurious emissions test is performed about the worst case of modulation type (QPSK).
- 11) Sample calculations

30 MHz ~ 1 GHz

$$13.89 \text{ dB}\mu\text{V (measured)} + 9.54 \text{ (distance)} - 104.77 + 24.49 \text{ (AFCL)} = -56.85 \text{ dBm}$$

1 GHz ~ 18 GHz

$$44.26 \text{ dB}\mu\text{V (measured)} + 9.54 \text{ (distance)} + 1.301 \text{ (Duty)} - 104.77 - 8.28 \text{ (AFCL)} = -57.95 \text{ dBm}$$

18 GHz ~ 36 GHz

$$21.96 \text{ dB}\mu\text{V (measured)} + 9.54 \text{ (distance)} + 1.301 \text{ (Duty)} - 104.77 + 48.82 \text{ (AFCL)} = -23.15 \text{ dBm}$$

41 GHz ~ 200 GHz

$$62.27 \text{ dB}\mu\text{V (measured)} + 9.54 \text{ (distance)} + 1.301 \text{ (Duty)} - 104.77 = -31.66 \text{ dBm}$$

Test Results:
1. 8CC Contiguous
Tabular Data of Radiated Spurious Emissions

Freq.	CH	Mod	Distance (m)	Ant. Pol.	Frequency (MHz)	Measured (dBuV)	Converted (dBm)	AFCL (dB)	Limit (dBm)	Result (dBm)
9 kHz ~ 150 kHz	L	64QAM	3.00	H	138.270	22.48	-72.75	17.76	-13	-24.99
	M				138.270	23.18	-72.05	17.76		-24.29
	H				138.270	22.99	-72.24	17.76		-24.48
150 kHz ~ 30 MHz	L		3.00	H	150.000	28.66	-66.57	17.76		-28.81
	M				150.000	28.39	-66.84	17.76		-29.08
	H				150.000	28.30	-66.93	17.76		-29.17
30 MHz ~ 1 GHz	L		3.00	H	704.756	13.89	-81.34	24.49		-56.85
	M				712.880	13.94	-81.29	24.52		-56.77
	H				744.041	13.94	-81.29	25.29		-56.00
1 GHz - 18 GHz	L		3.00	H	3.936	44.26	-49.67	-8.28		-57.95
					5.457	45.07	-48.86	-3.83		-52.69
	M				3.936	43.81	-50.12	-8.28		-58.40
					5.457	44.78	-49.15	-3.83		-52.98
					3.936	43.95	-49.98	-8.28		-58.26
H	5.457		44.64	-49.29	-3.83	-53.12				
	18 GHz ~ 36 GHz		3.00	H	35.728	21.96	-71.97	48.82		-23.15
35.874					22.14	-71.79	49.41	-22.38		
33.686*					33.67	-60.26	47.99	-12.27		
Freq.	CH		Distance (m)	Ant. Pol.	Frequency (MHz)	Measured (dBuV)	Result (dBm)			
41 GHz ~ 60 GHz	L		3.00	H	45.795	62.27	-31.66			
	M				45.215	62.30	-31.63			
	H				45.564	62.39	-31.54			
41 GHz ~ 60 GHz	L		3.00	H	89.919	57.48	-36.45			
	M				89.933	57.47	-36.46			
	H	89.945			57.37	-36.56				
41 GHz ~ 60 GHz	L	3.00	H	104.710	82.88	-24.11				
	M			104.362	82.79	-24.20				
	H			104.755	82.99	-24.00				
41 GHz ~ 60 GHz	L	3.00	H	150.243	100.01	-19.02				
	M			150.201	99.91	-19.12				
	H			150.221	99.94	-19.09				
41 GHz ~ 60 GHz	L	3.00	H	187.266	76.79	-32.70				
	M			187.271	77.03	-32.46				
	H			187.251	76.70	-32.79				

Note:

1. Because of no critical emissions are detected in the test, only peak value is recorded in this report.
2. '**' This checked frequency is measured by TRP, because it is EIRP fail

2. 1CC + 1CC Non-Contiguous
Tabular Data of Radiated Spurious Emissions

Freq.	CH	Mod	Distance (m)	Ant. Pol.	Frequency (MHz)	Measured (dBuV)	Converted (dBm)	AFCL (dB)	Limit (dBm)	Result (dBm)
9 kHz ~ 150 kHz	L	64QAM	3.00	H	138.270	22.71	-72.52	17.76	-13	-24.76
	M				138.270	22.50	-72.73	17.76		-24.97
	H				136.020	22.41	-72.82	17.76		-25.06
150 kHz ~ 30 MHz	L		3.00	H	150.000	28.22	-67.01	17.76		-29.25
	M				150.000	28.31	-66.92	17.76		-29.16
	H				150.000	28.06	-67.17	17.76		-29.41
30 MHz ~ 1 GHz	L		3.00	H	742.829	13.97	-81.26	25.29		-55.97
	M				747.436	13.87	-81.36	25.51		-55.85
	H				744.769	13.90	-81.33	25.39		-55.94
1 GHz - 18 GHz	L		3.00	H	3.936	43.23	-50.70	-8.28		-58.98
					5.457	44.74	-49.19	-3.83		-53.02
	M				3.936	43.70	-50.23	-8.28		-58.51
					5.457	44.58	-49.35	-3.83		-53.18
	H				3.936	43.81	-50.12	-8.28		-58.40
					5.457	44.86	-49.07	-3.83		-52.90
18 GHz ~ 36 GHz	L		3.00	H	35.748	26.28	-67.65	48.82		-18.82
	M				35.992	22.60	-71.33	49.30		-22.03
	H				33.686*	33.74	-60.19	47.99		-12.21
Freq.	CH		Distance (m)	Ant. Pol.	Frequency (MHz)	Measured (dBuV)	Result (dBm)			
41 GHz ~ 60 GHz	L		3.00	H	45.369	62.39	-31.54			
	M				45.574	62.29	-31.64			
	H				45.803	62.22	-31.71			
41 GHz ~ 60 GHz	L		3.00	H	89.928	57.30	-36.63			
	M				89.948	57.26	-36.67			
	H	89.946			57.37	-36.56				
41 GHz ~ 60 GHz	L	3.00	H	104.726	82.86	-24.13				
	M			104.394	83.08	-23.91				
	H			105.083	82.90	-24.09				
41 GHz ~ 60 GHz	L	3.00	H	150.147	99.97	-19.06				
	M			150.174	99.97	-19.06				
	H			150.247	99.91	-19.12				
41 GHz ~ 60 GHz	L	3.00	H	187.277	76.77	-32.72				
	M			187.279	76.73	-32.76				
	H			187.277	76.85	-32.64				

Note:

1. Because of no critical emissions are detected in the test, only peak value is recorded in this report.
2. '** This checked frequency is measured by TRP, because it is EIRP fail

TRP Results.

CC / CH / Mod	Frequency [GHz]	Result [dBm]	Limit [dBm]	Margin [dB]
8cc / H / 64QAM / Contiguous	33.686	-18.77	-13	5.77
1cc + 1cc / H / 64QAM / Non-Contiguous		-17.64		4.64

Plot data of Radiated Spurious Emissions

9 kHz ~ 150 kHz / 8cc / Low / H / Contiguous

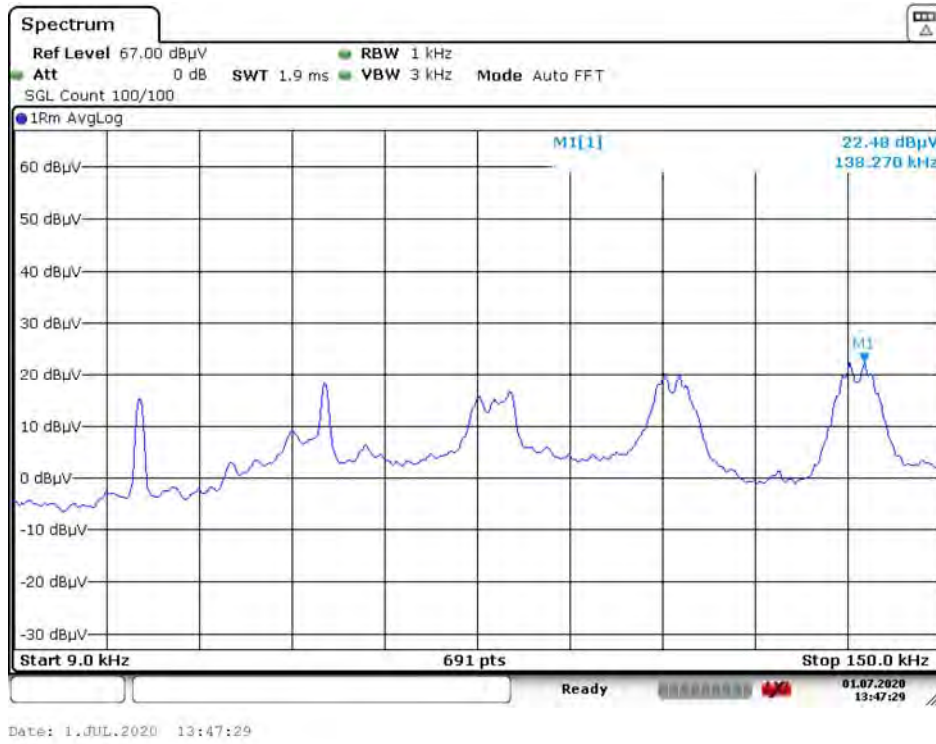

9 kHz ~ 150 kHz / 8cc / Middle / H / Contiguous

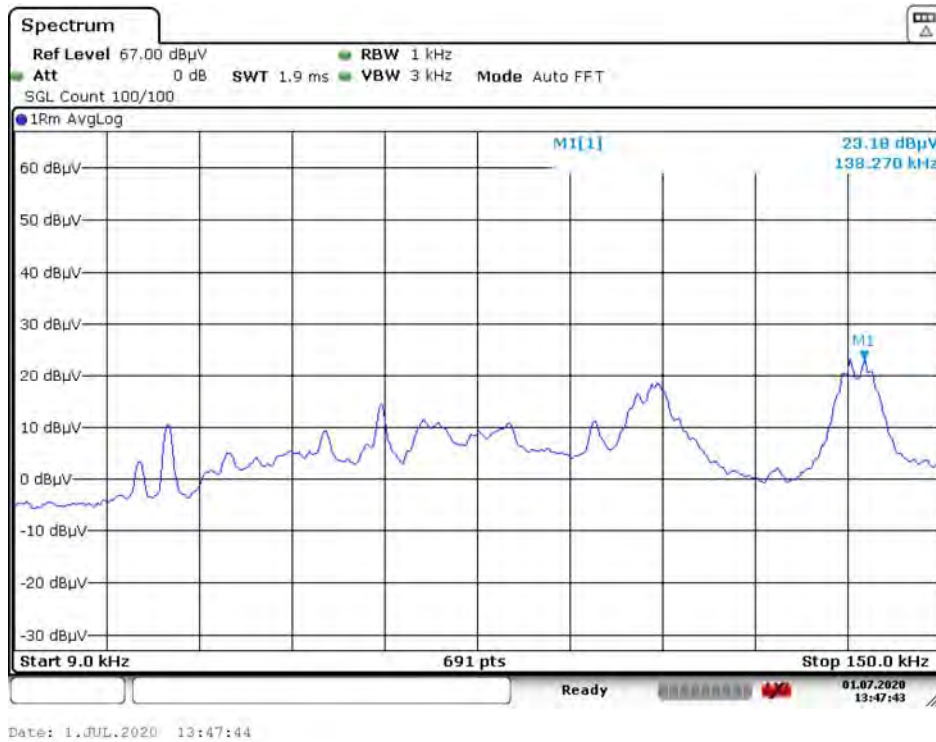

9 kHz ~ 150 kHz / 8cc / High / H / Contiguous

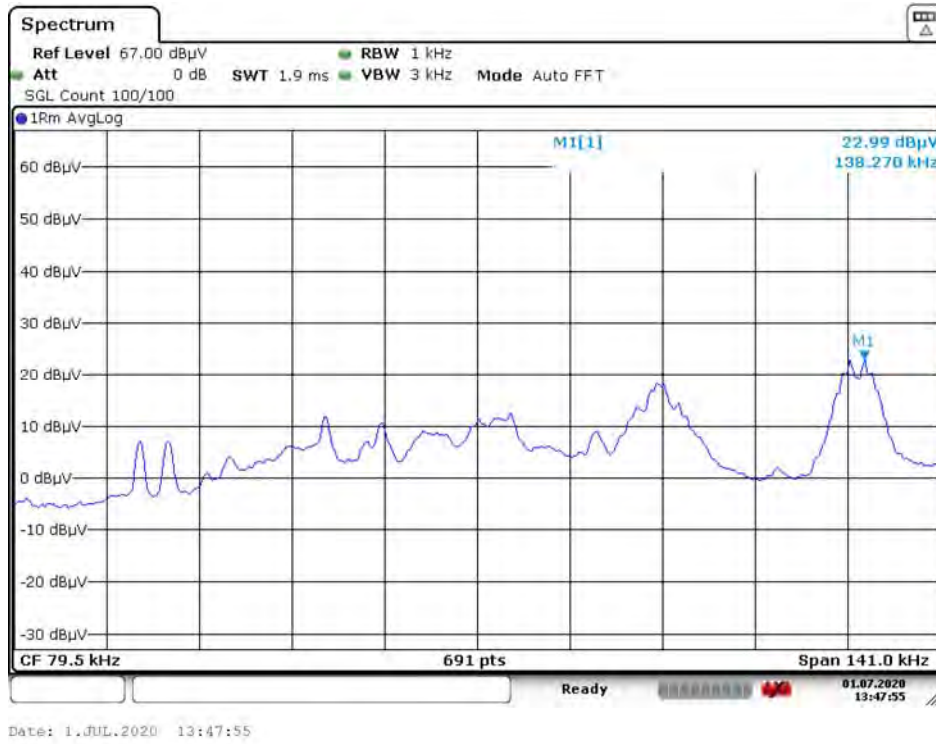

150 kHz ~ 30 MHz / 8cc / Low / H / Contiguous

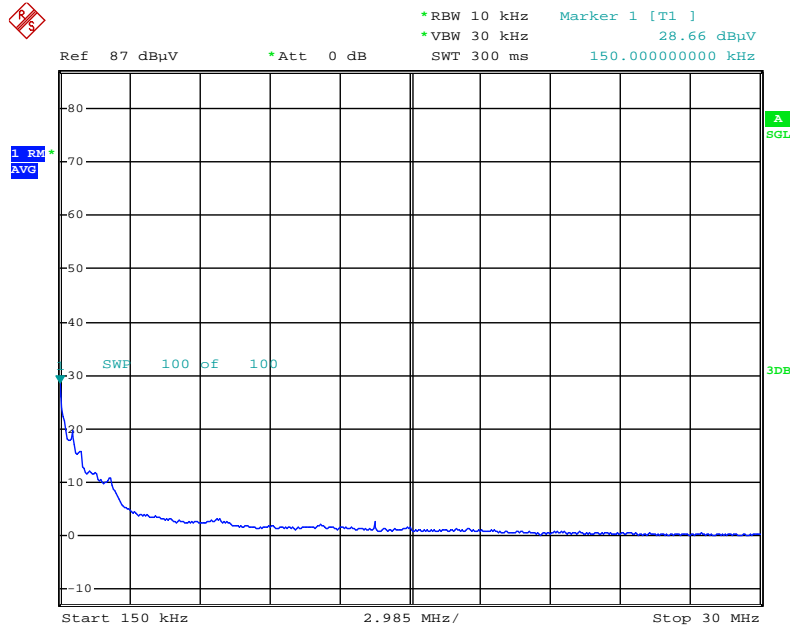

150 kHz ~ 30 MHz / 8cc / Middle / H / Contiguous

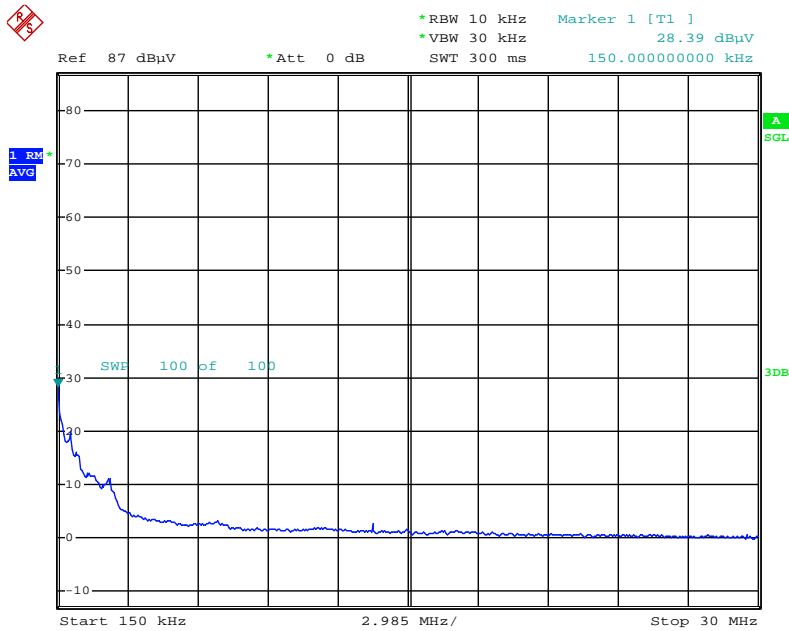

150 kHz ~ 30 MHz / 8cc / High / H / Contiguous

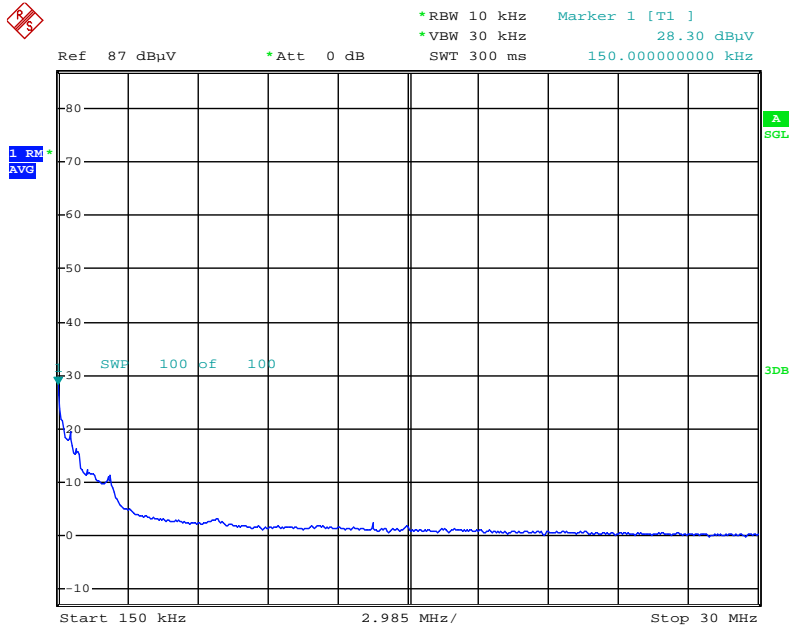

30 MHz ~ 1 GHz / 8cc / Low / H / Contiguous

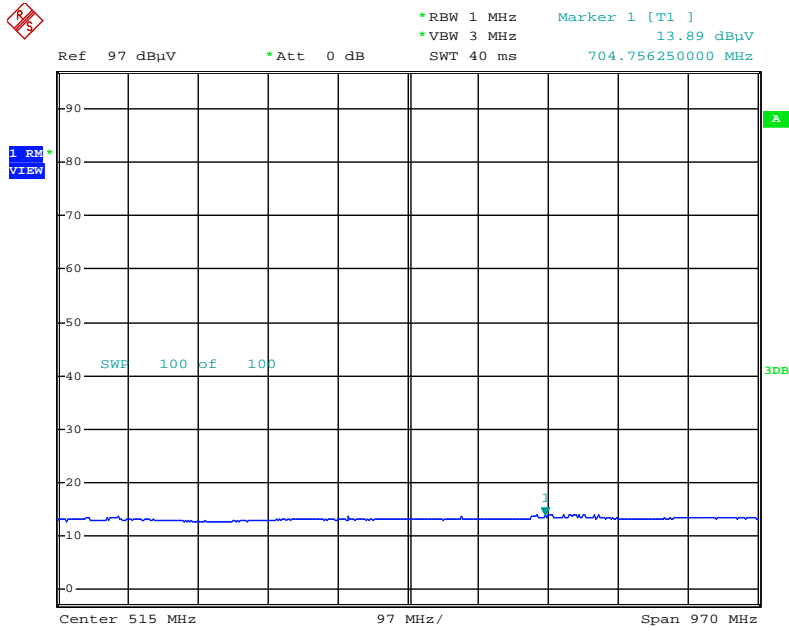

30 MHz ~ 1 GHz / 8cc / Middle / H / Contiguous

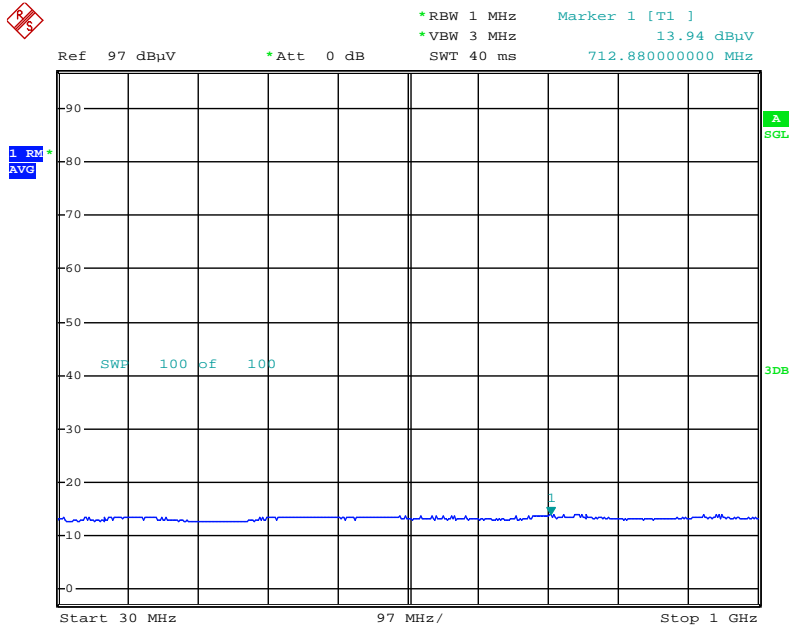

30 MHz ~ 1 GHz / 8cc / High / H / Contiguous

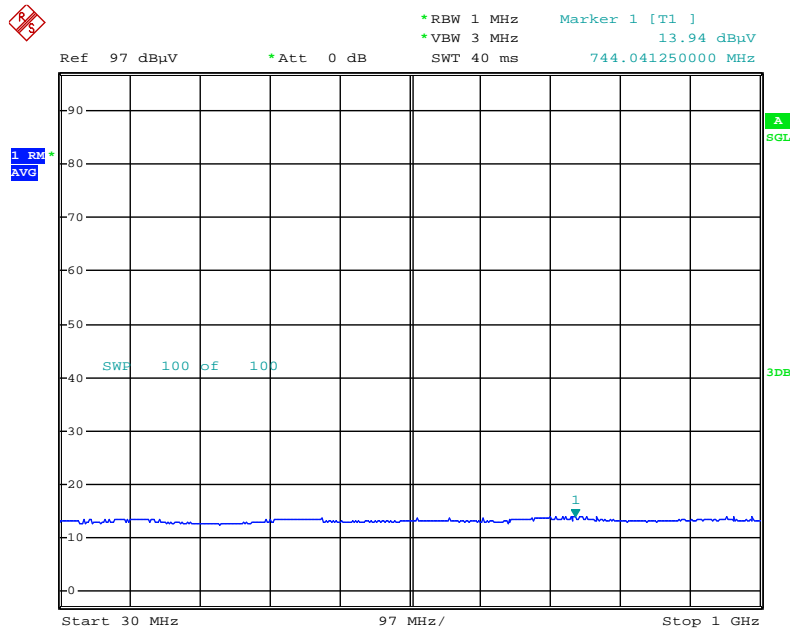

1 GHz - 18 GHz / 8cc / Low / H / Contiguous



1 GHz - 18 GHz / 8cc / Middle / H / Contiguous



1 GHz - 18 GHz / 8cc / High / H / Contiguous



18 GHz ~ 36 GHz / 8cc / Low / H / Contiguous



18 GHz ~ 36 GHz / 8cc / Middle / H / Contiguous

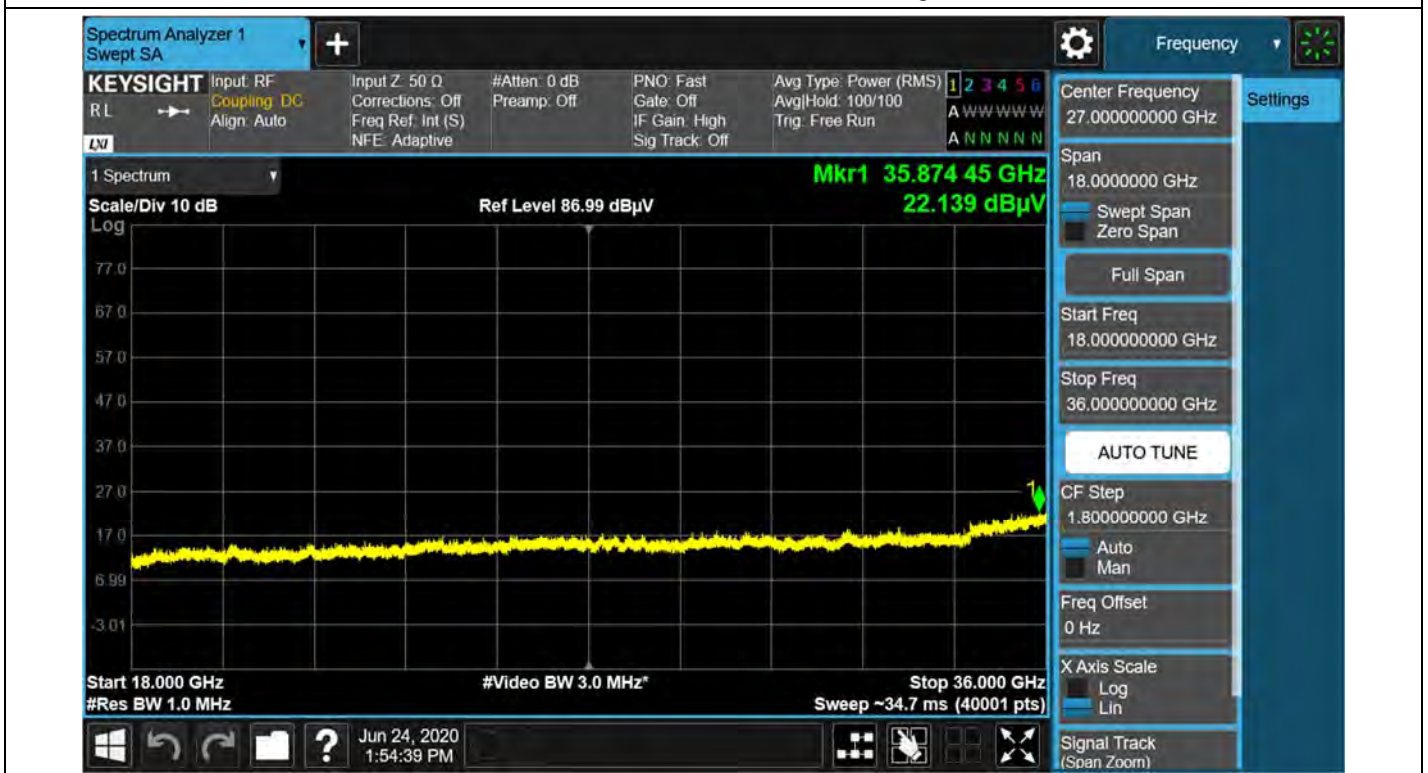

18 GHz ~ 36 GHz / 8cc / High / H / Contiguous

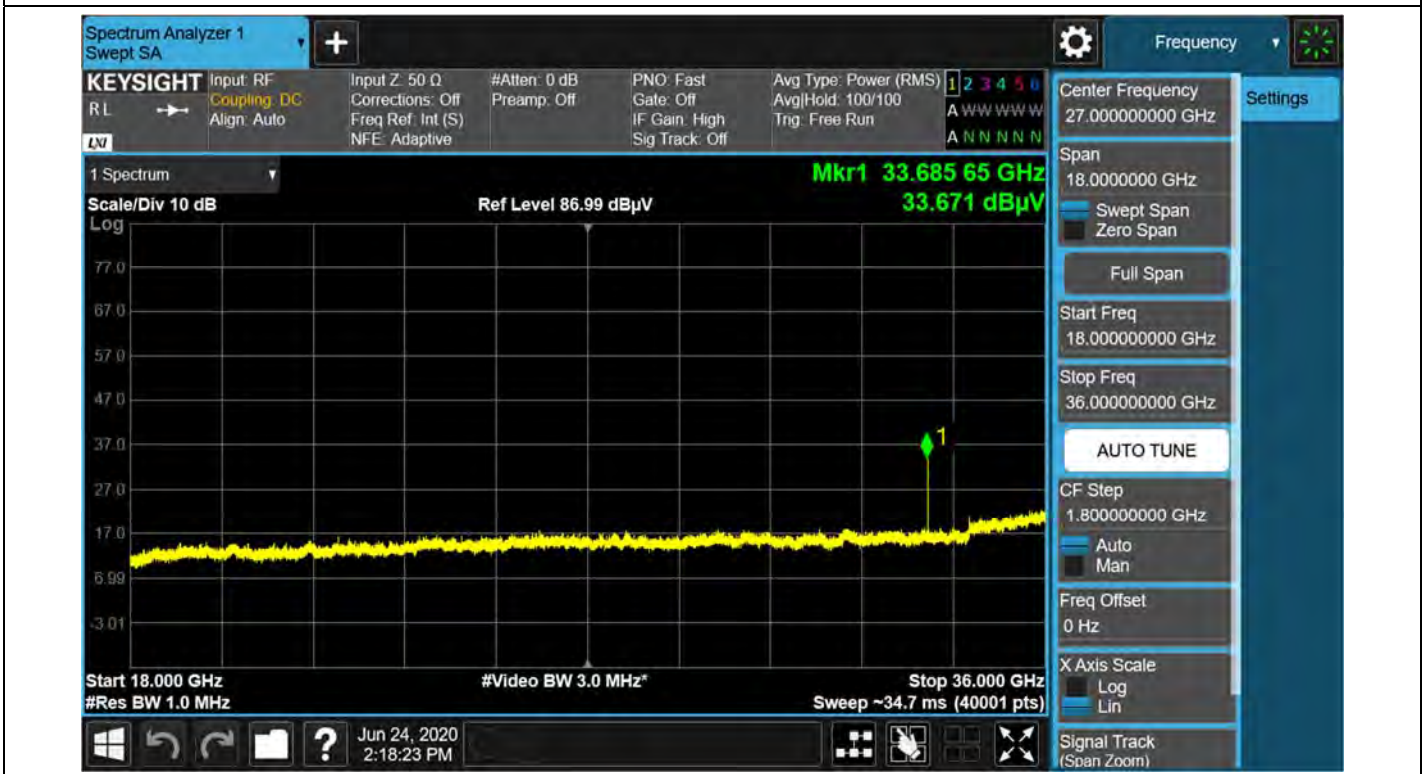

41 GHz ~ 60 GHz / 8cc / Low / H / Contiguous

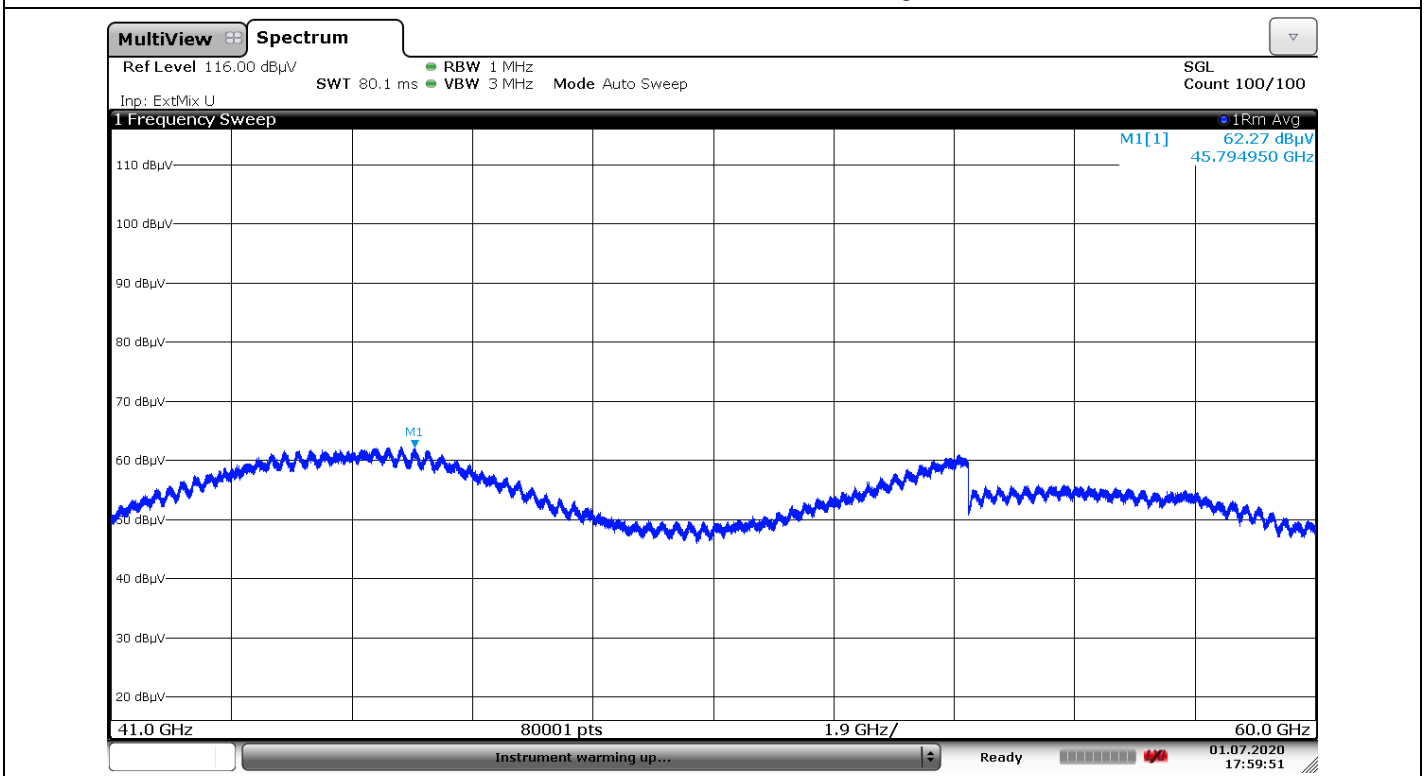

41 GHz ~ 60 GHz / 8cc / Middle / H / Contiguous

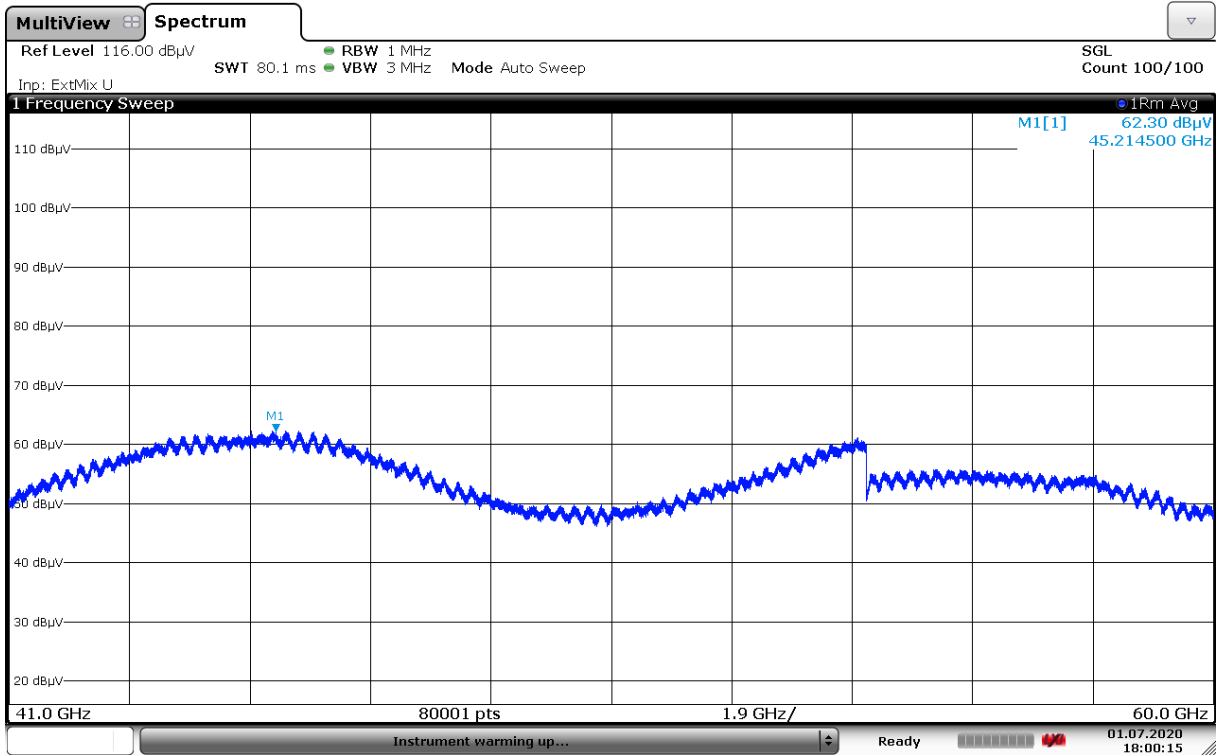

41 GHz ~ 60 GHz / 8cc / High / H / Contiguous

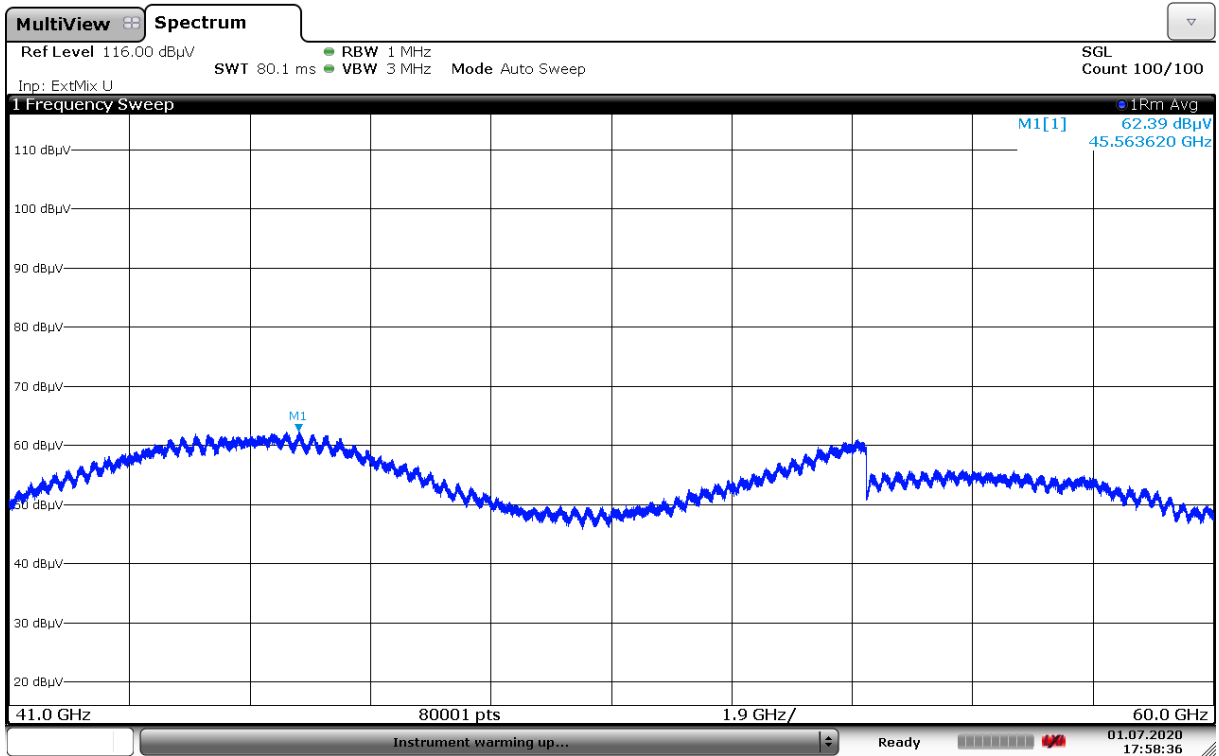

60 GHz ~ 90 GHz / 8cc / Low / H / Contiguous

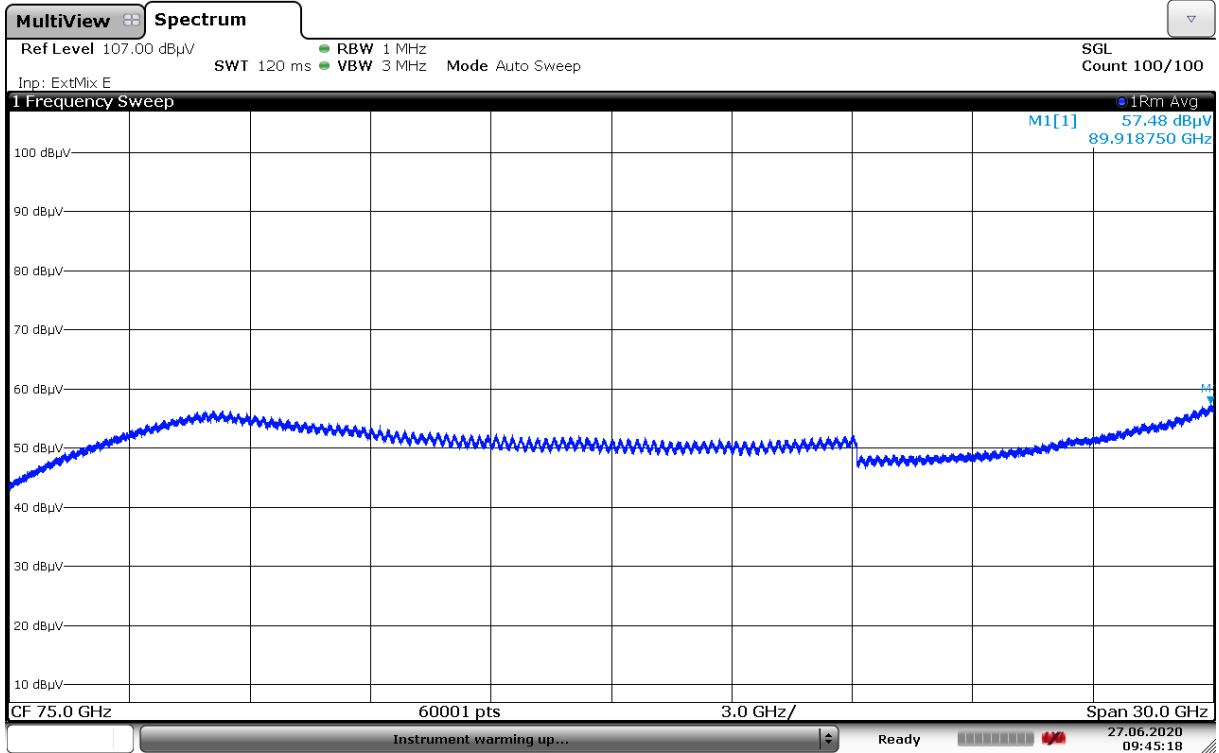

60 GHz ~ 90 GHz / 8cc / Middle / H / Contiguous

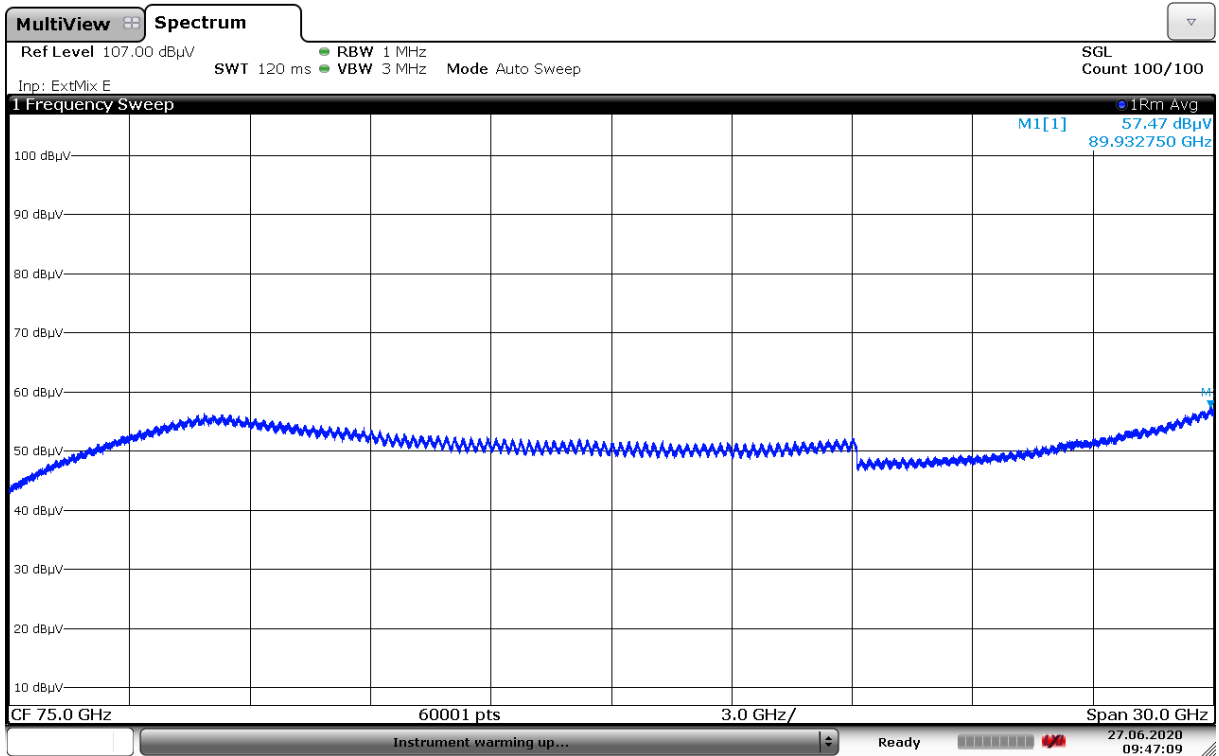

60 GHz ~ 90 GHz / 8cc / High / H / Contiguous

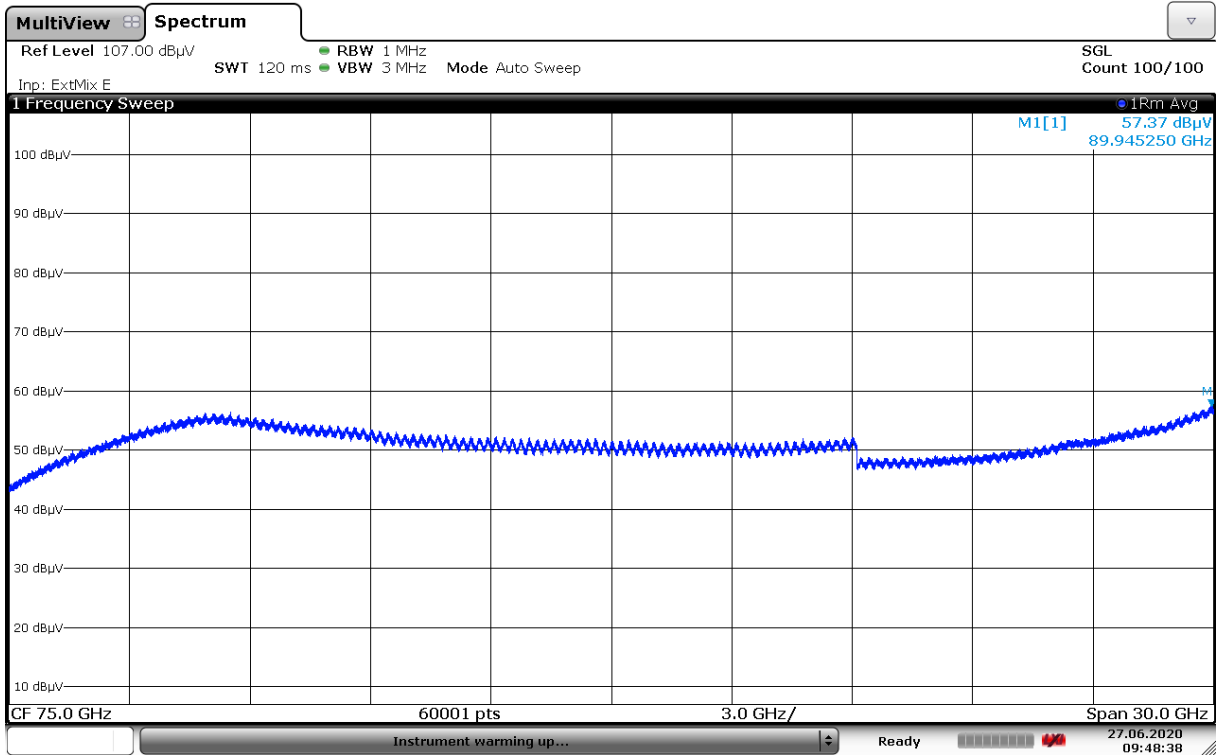

90 GHz ~ 140 GHz / 8cc / Low / H / Contiguous

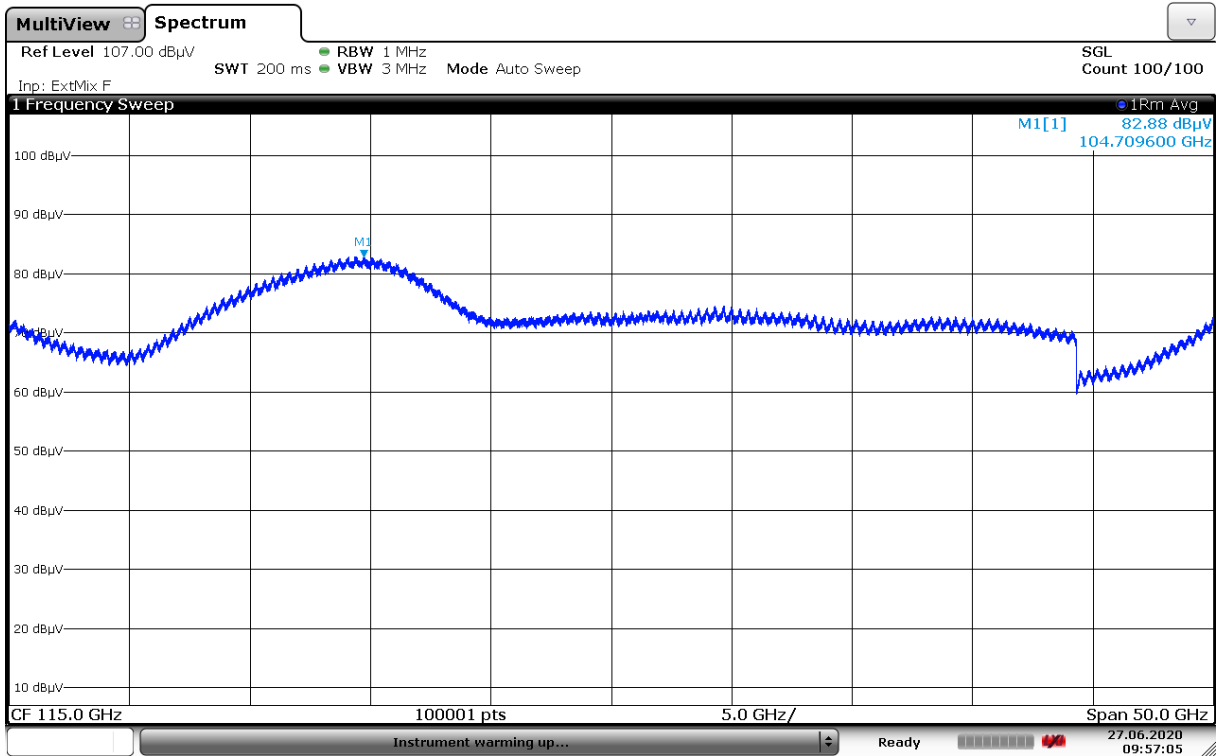

90 GHz ~ 140 GHz / 8cc / Middle / H / Contiguous

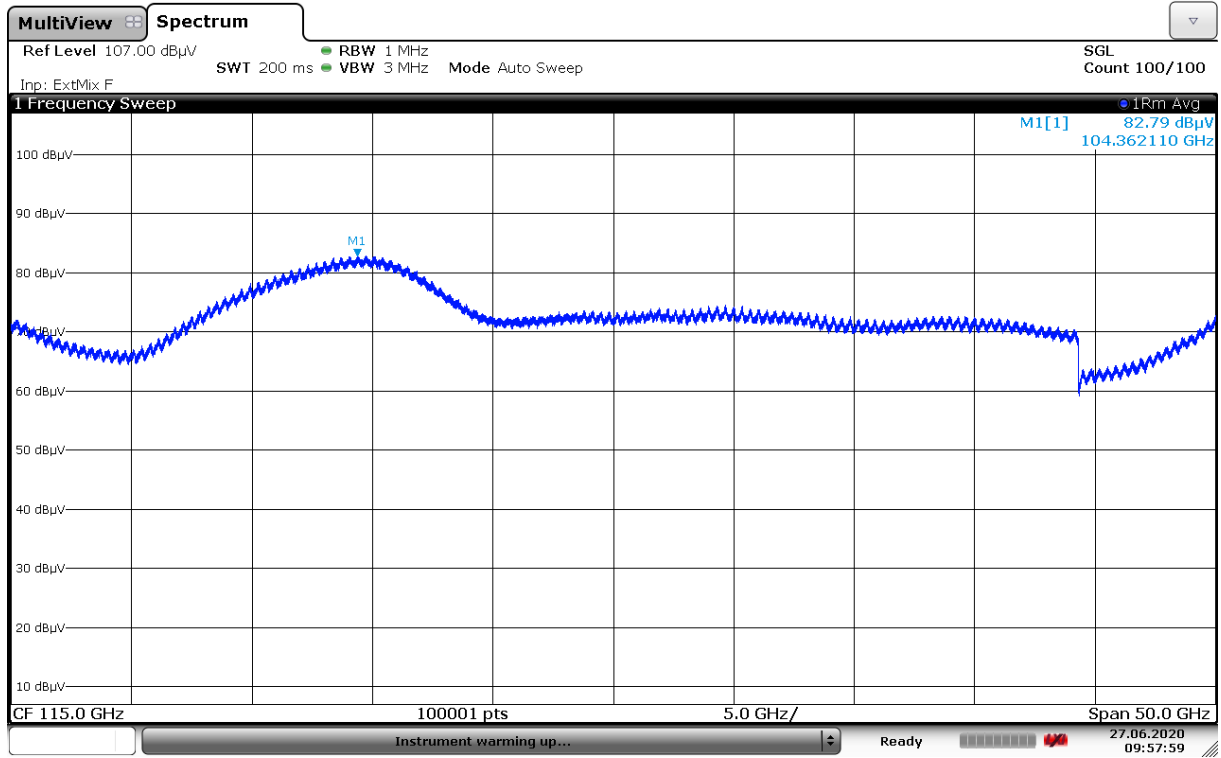

90 GHz ~ 140 GHz / 8cc / High / H / Contiguous

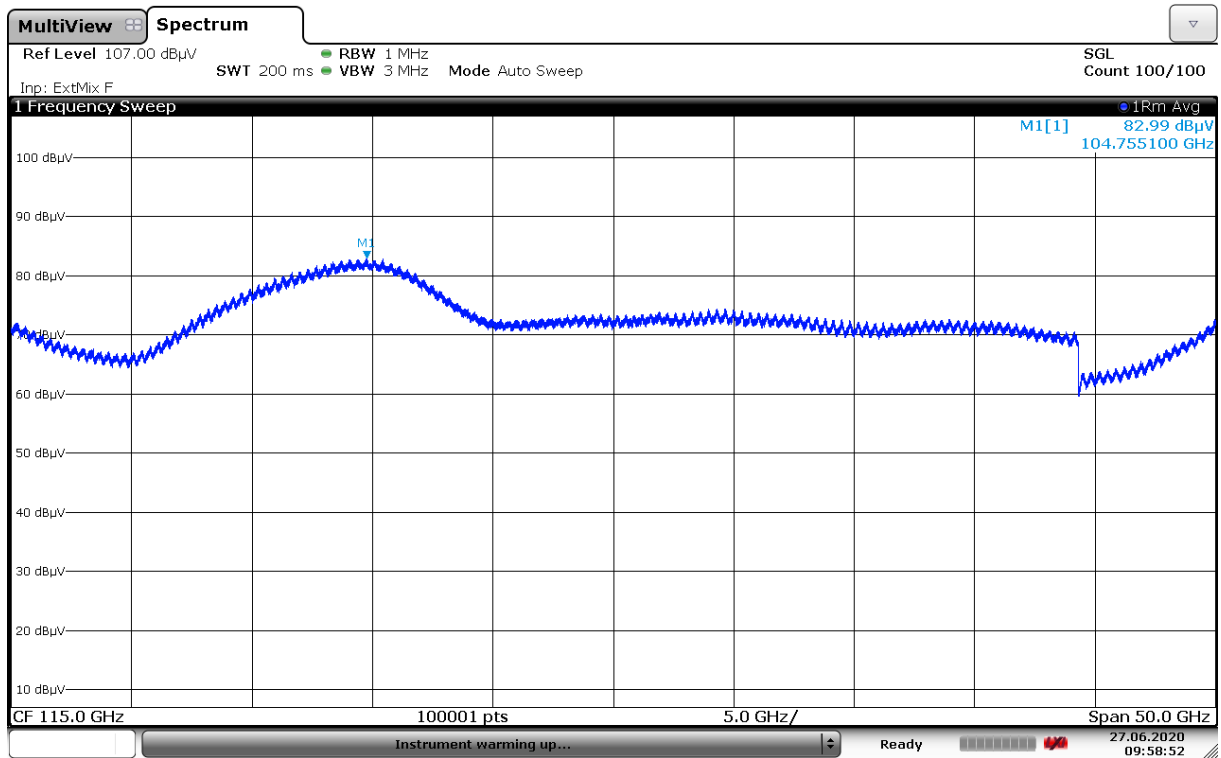

140 GHz ~ 180 GHz / 8cc / Low / H / Contiguous

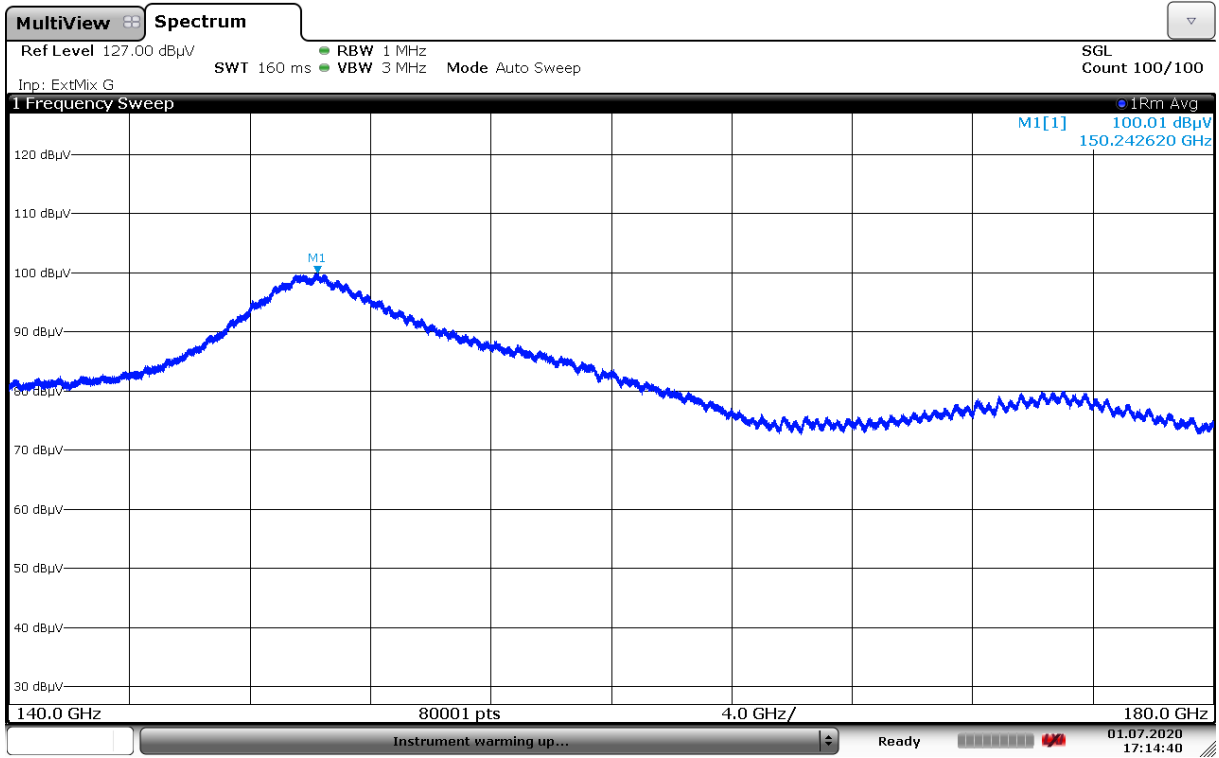

140 GHz ~ 180 GHz / 8cc / Middle / H / Contiguous

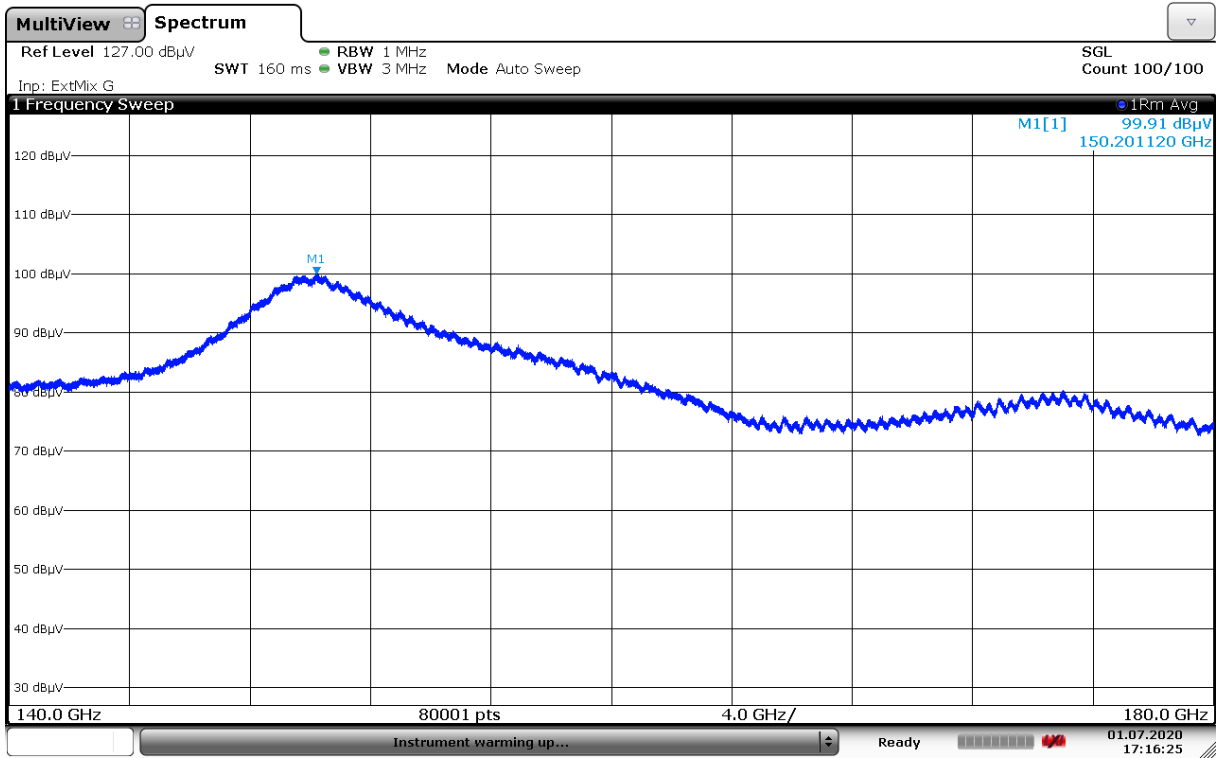

140 GHz ~ 180 GHz / 8cc / High / H / Contiguous

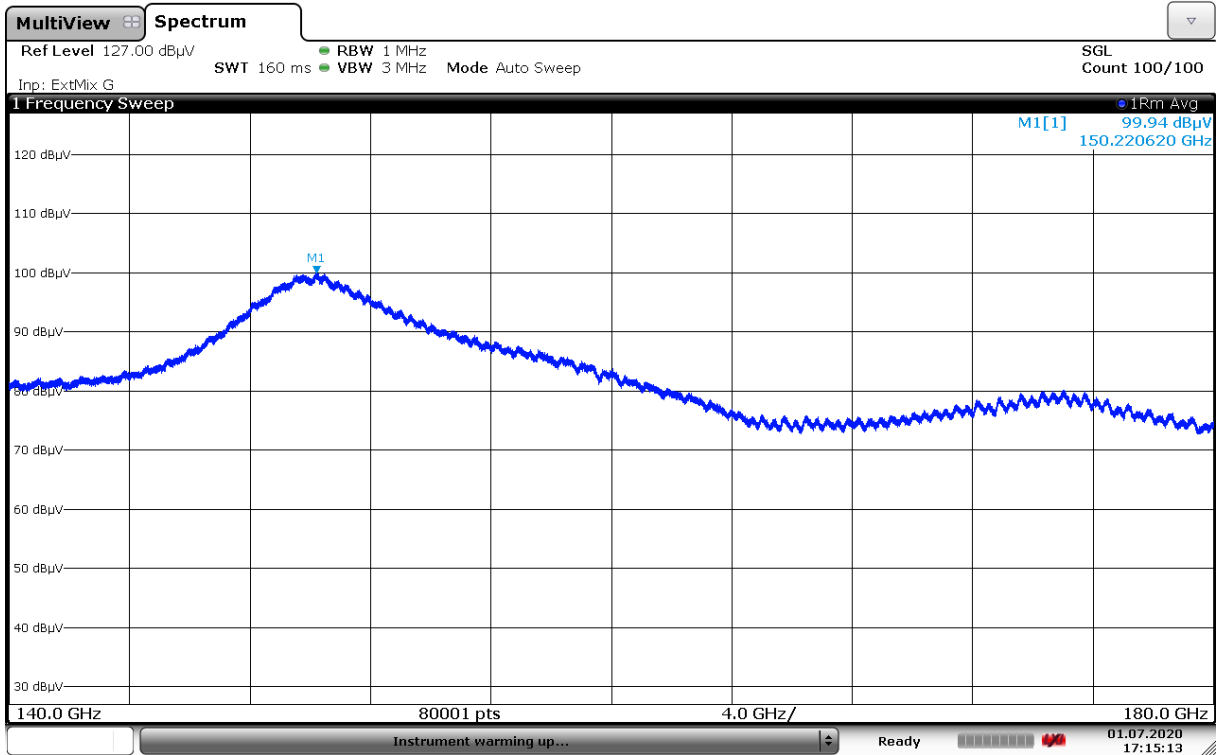

180 GHz ~ 200 GHz / 8cc / Low / H / Contiguous

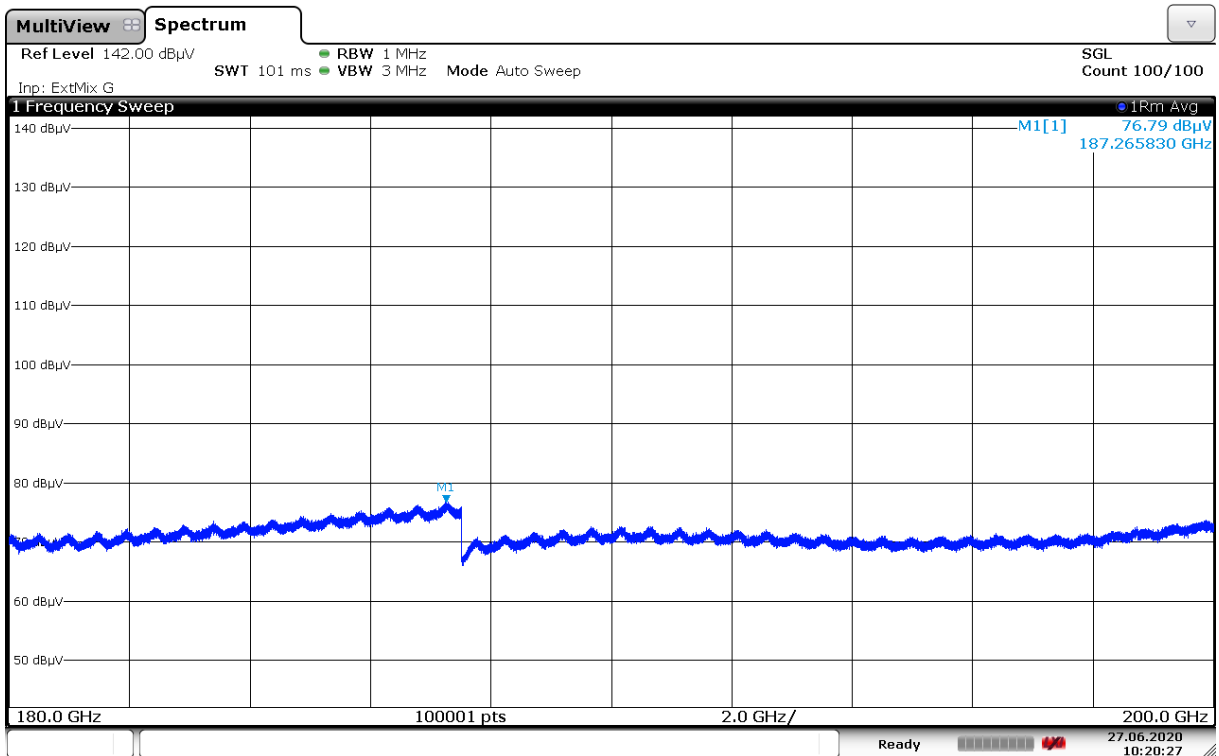

180 GHz ~ 200 GHz / 8cc / Middle / H / Contiguous

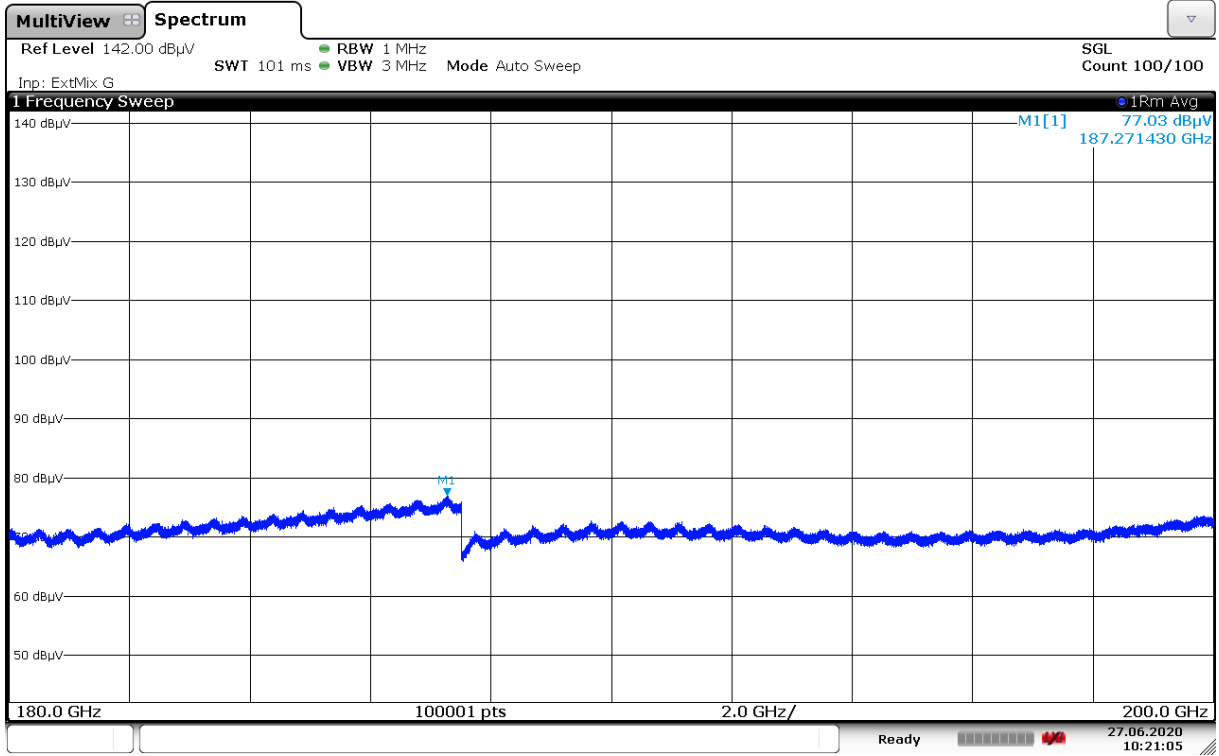

180 GHz ~ 200 GHz / 8cc / High / H / Contiguous

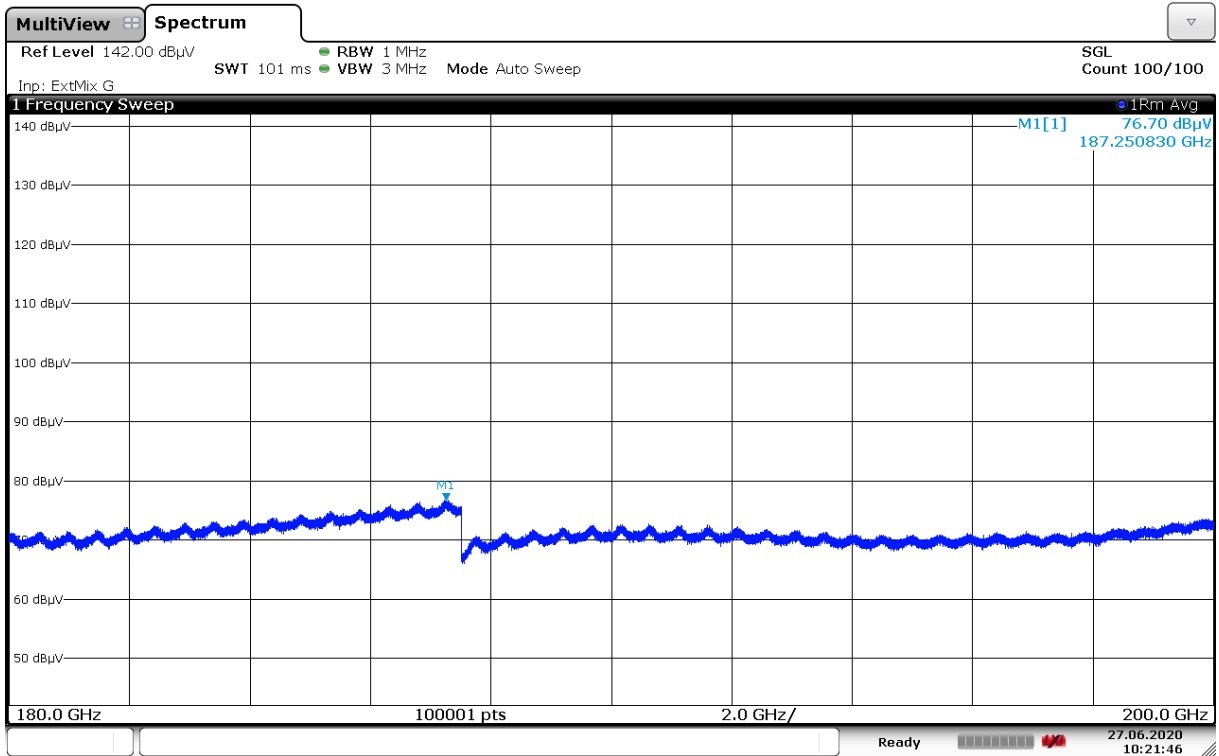

9 kHz ~ 150 kHz / 1cc + 1cc / Low / H / Non-Contiguous

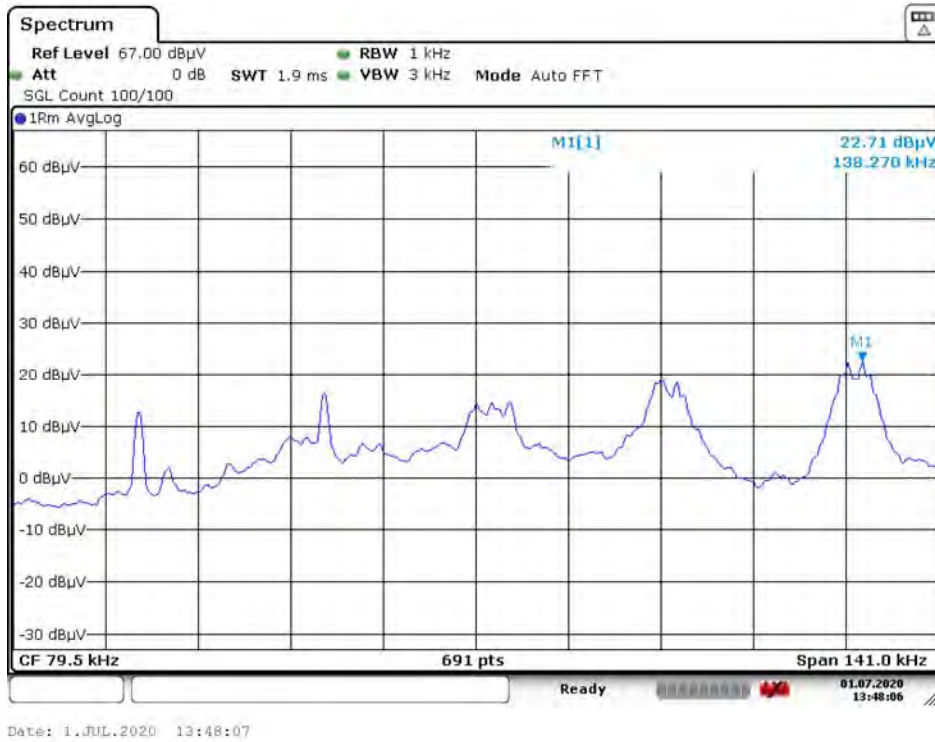

9 kHz ~ 150 kHz / 1cc + 1cc / Middle / H / Non-Contiguous



9 kHz ~ 150 kHz / 1cc + 1cc / High / H / Non-Contiguous



150 kHz ~ 30 MHz / 1cc + 1cc / Low / H / Non-Contiguous

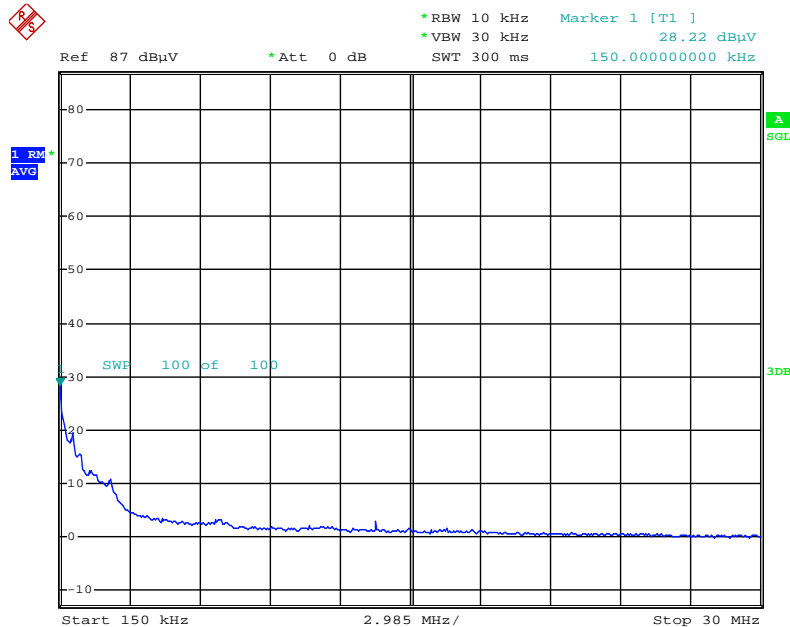

150 kHz ~ 30 MHz / 1cc + 1cc / Middle / H / Non-Contiguous

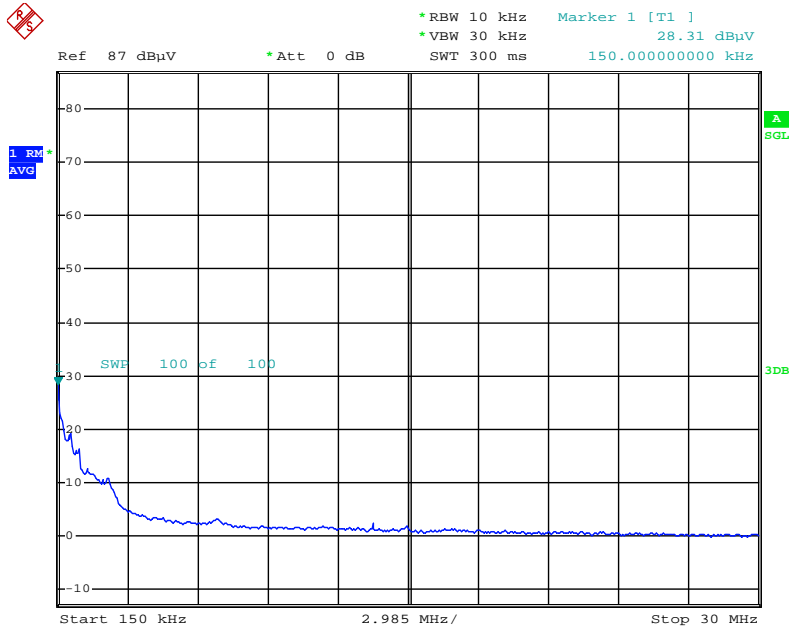

150 kHz ~ 30 MHz / 1cc + 1cc / High / H / Non-Contiguous

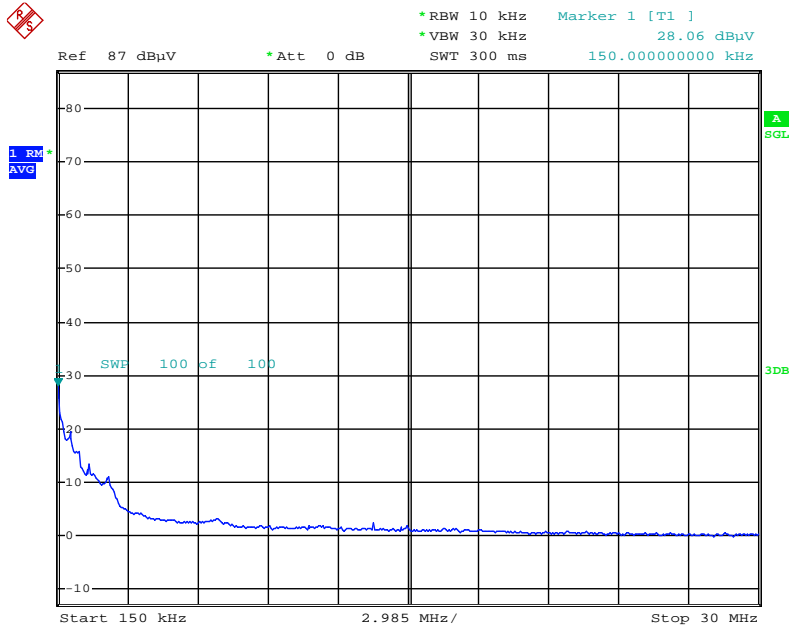

30 MHz ~ 1 GHz / 1cc + 1cc / Low / H / Non-Contiguous

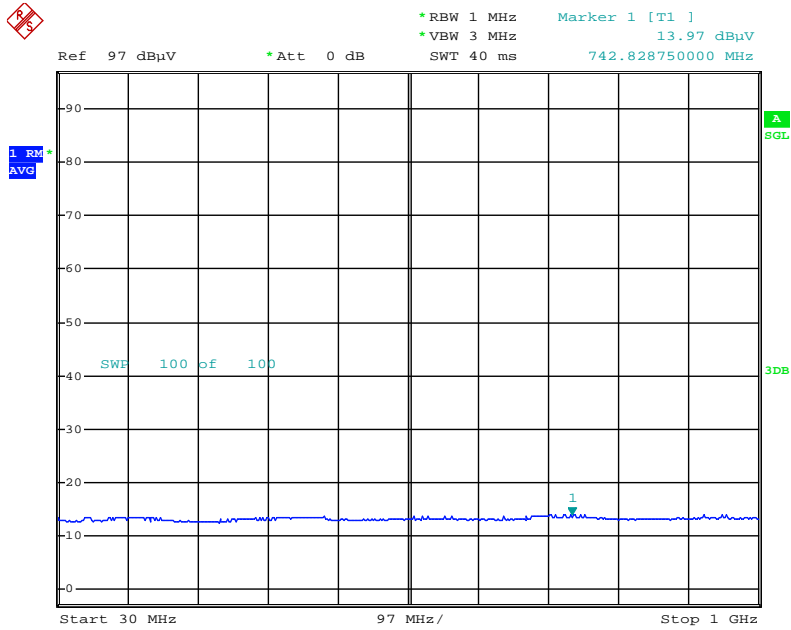

30 MHz ~ 1 GHz / 1cc + 1cc / Middle / H / Non-Contiguous

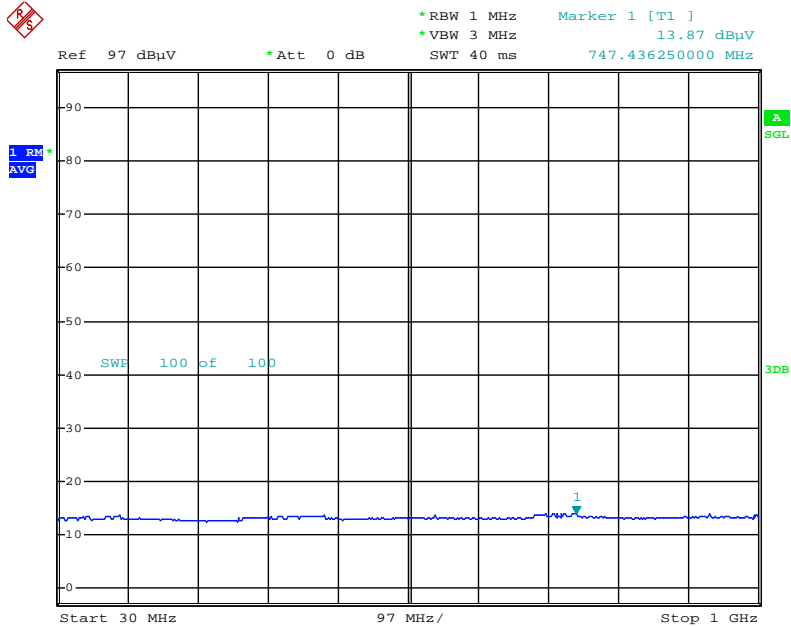

30 MHz ~ 1 GHz / 1cc + 1cc / High / H / Non-Contiguous

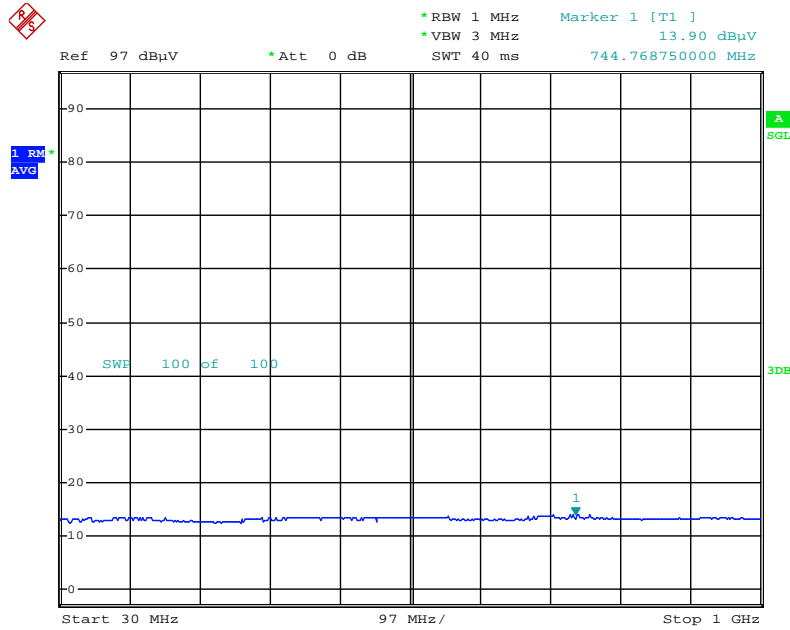

1 GHz - 18 GHz / 1cc + 1cc / Low / H / Non-Contiguous



1 GHz - 18 GHz / 1cc + 1cc / Middle / H / Non-Contiguous



1 GHz - 18 GHz / 1cc + 1cc / High / H / Non-Contiguous



18 GHz ~ 36 GHz / 1cc + 1cc / Low / H / Non-Contiguous

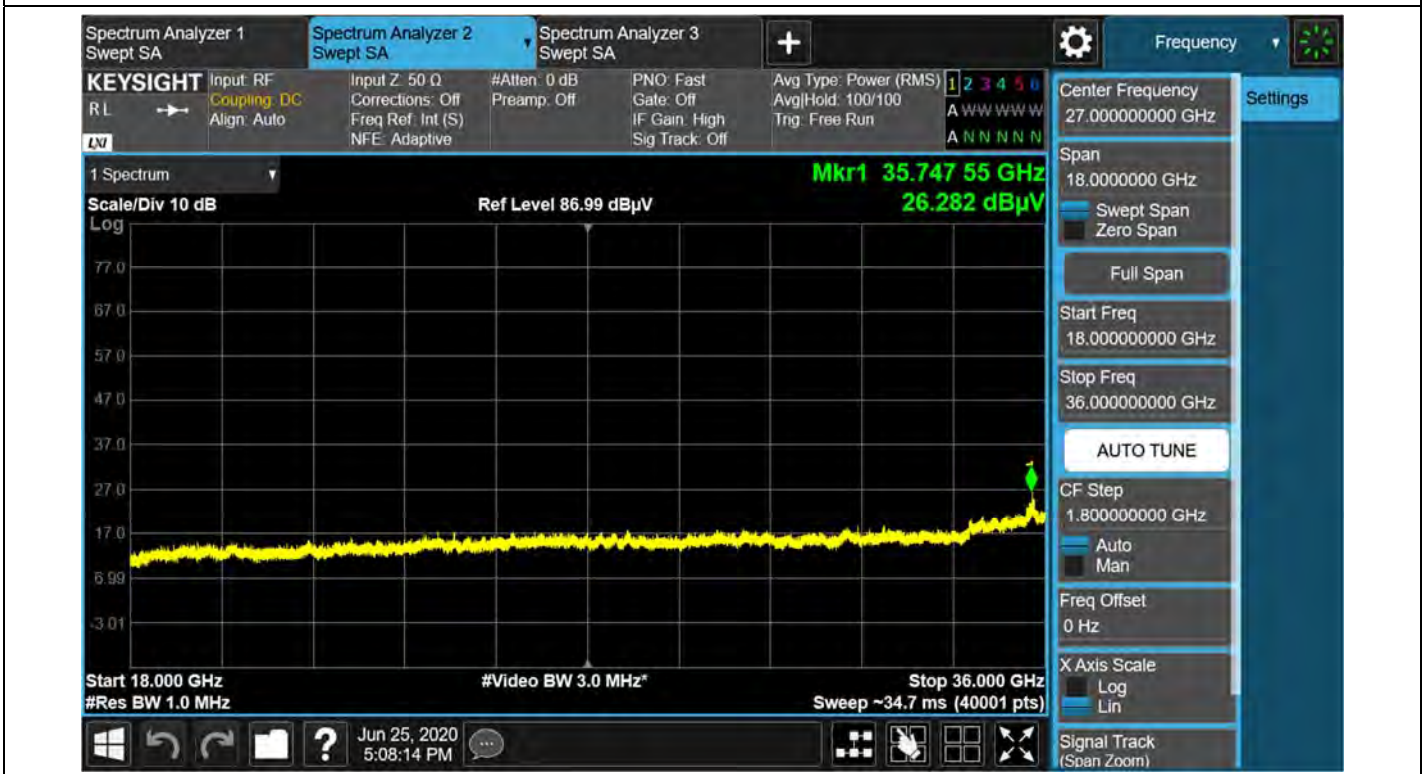

18 GHz ~ 36 GHz / 1cc + 1cc / Middle / H / Non-Contiguous

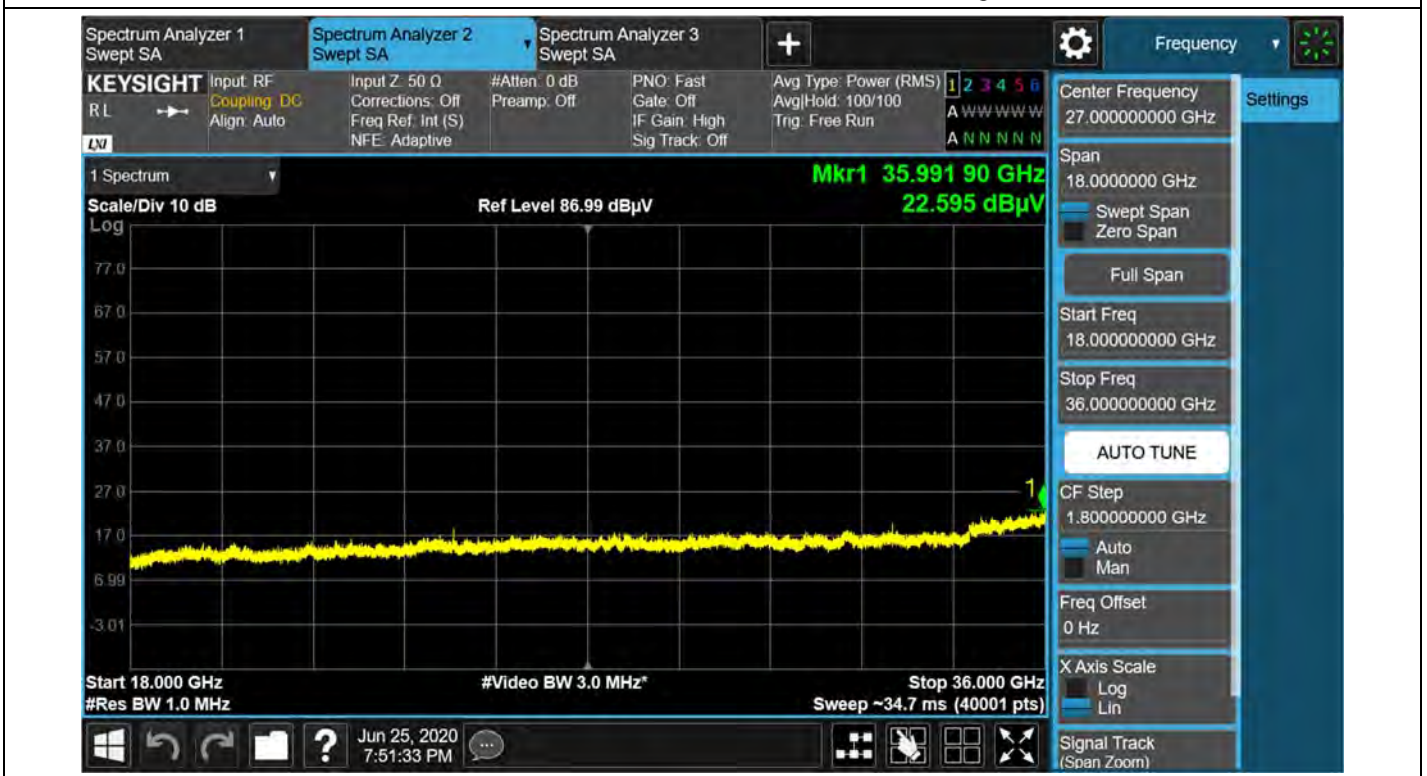

18 GHz ~ 36 GHz / 1cc + 1cc / High / H / Non-Contiguous

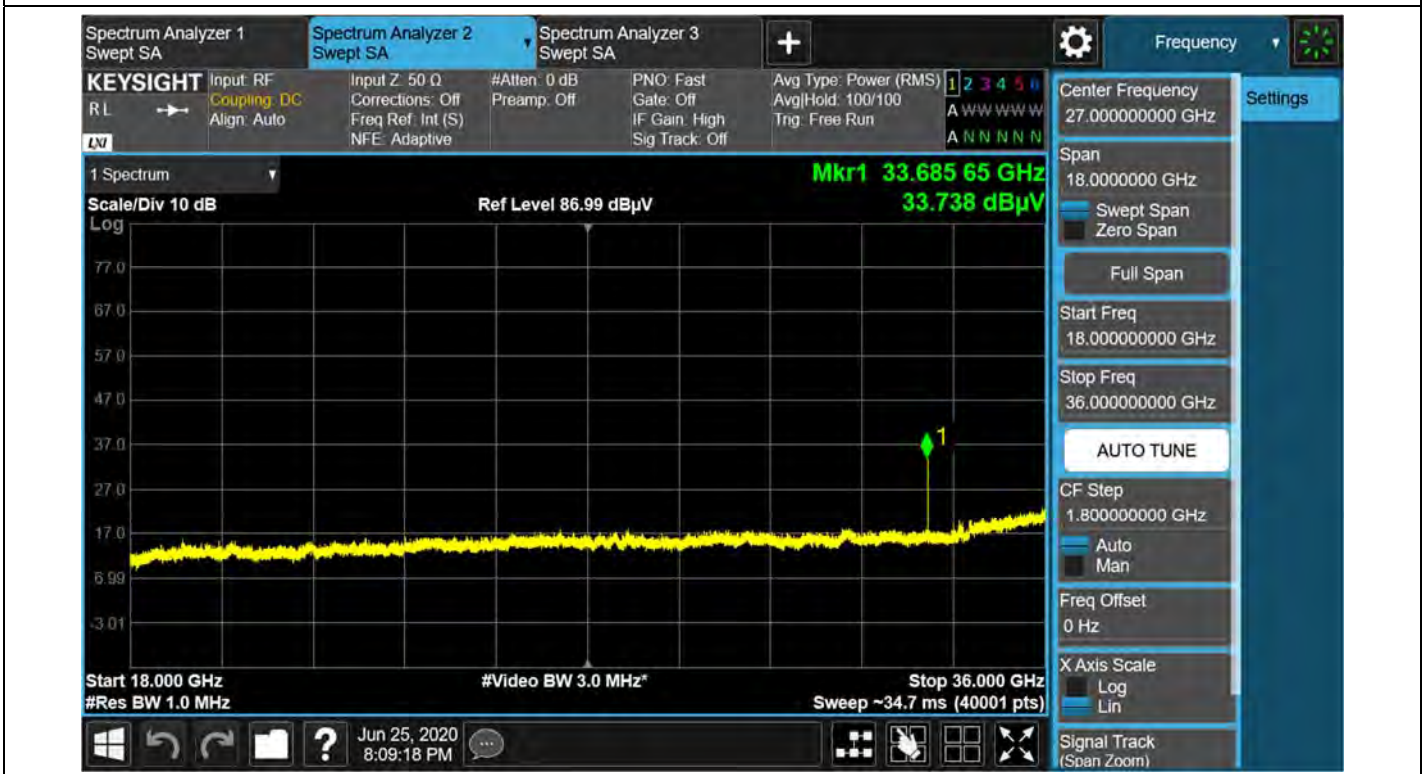

41 GHz ~ 60 GHz / 1cc + 1cc / Low / H / Non-Contiguous

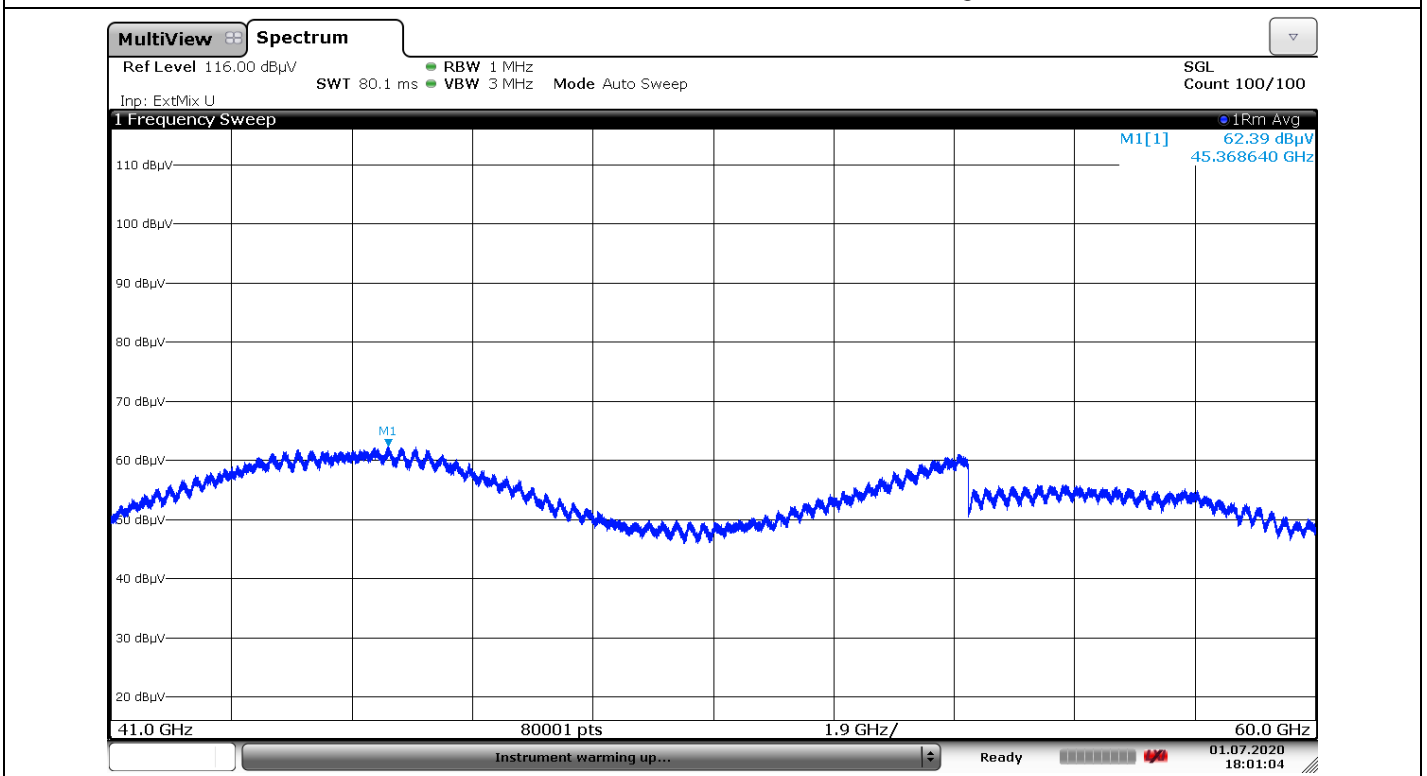

41 GHz ~ 60 GHz / 1cc + 1cc / Middle / H / Non-Contiguous

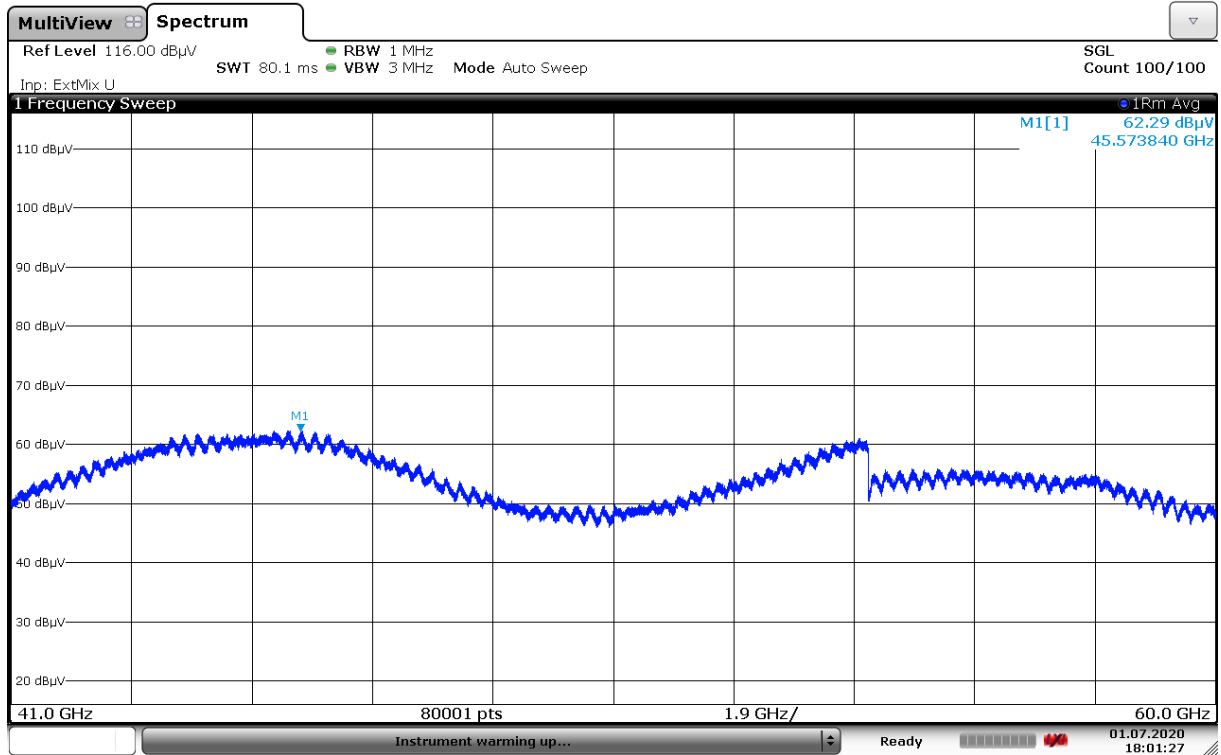

41 GHz ~ 60 GHz / 1cc + 1cc / High / H / Non-Contiguous

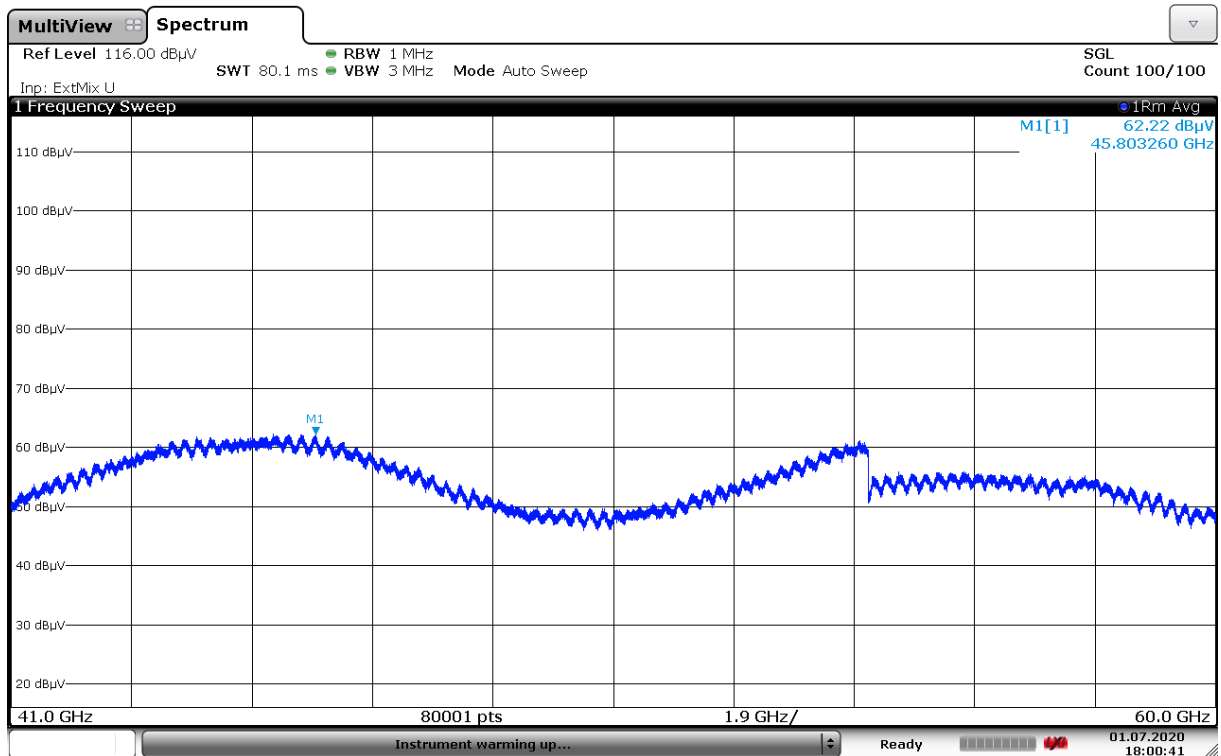

60 GHz ~ 90 GHz / 1cc + 1cc / Low / H / Non-Contiguous

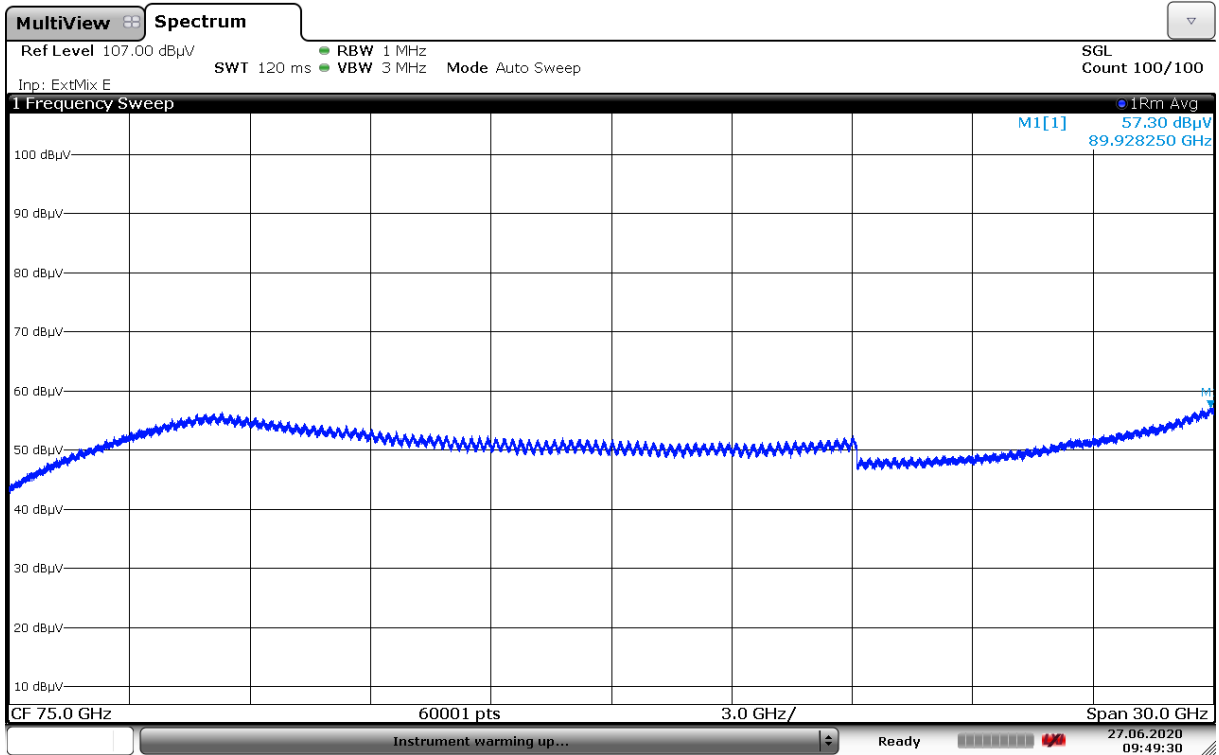

60 GHz ~ 90 GHz / 1cc + 1cc / Middle / H / Non-Contiguous

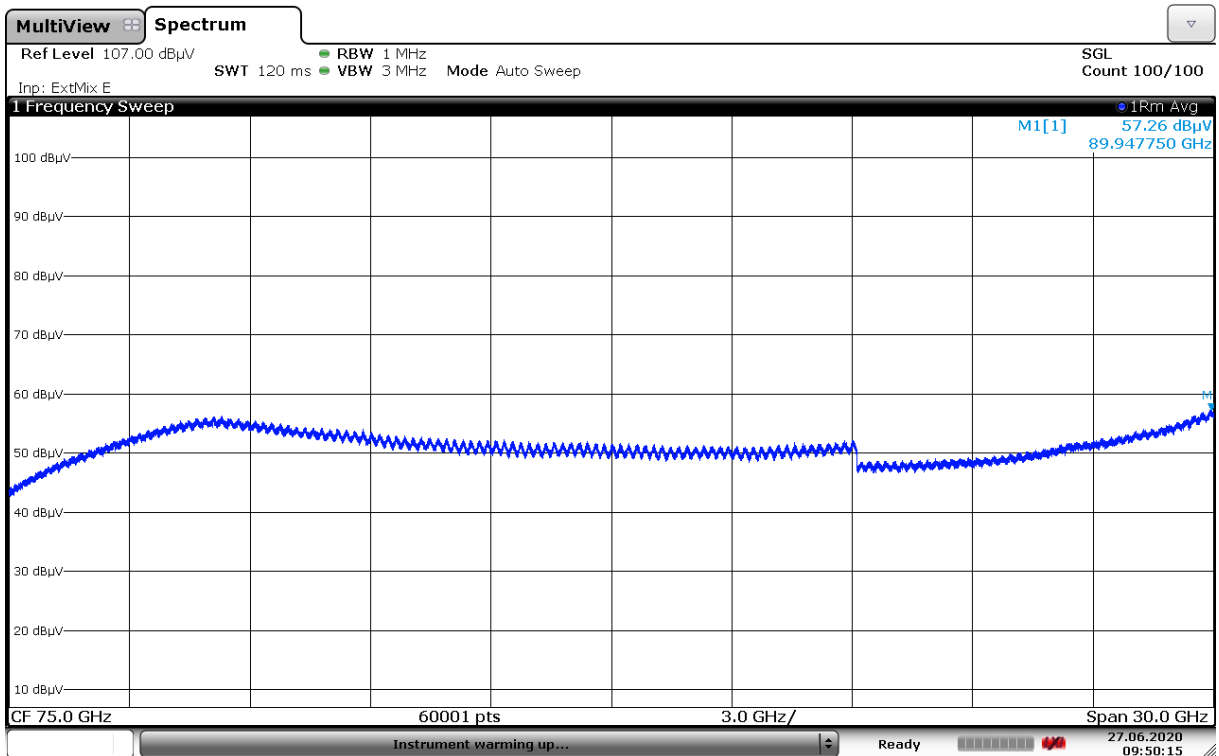

60 GHz ~ 90 GHz / 1cc + 1cc / High / H / Non-Contiguous

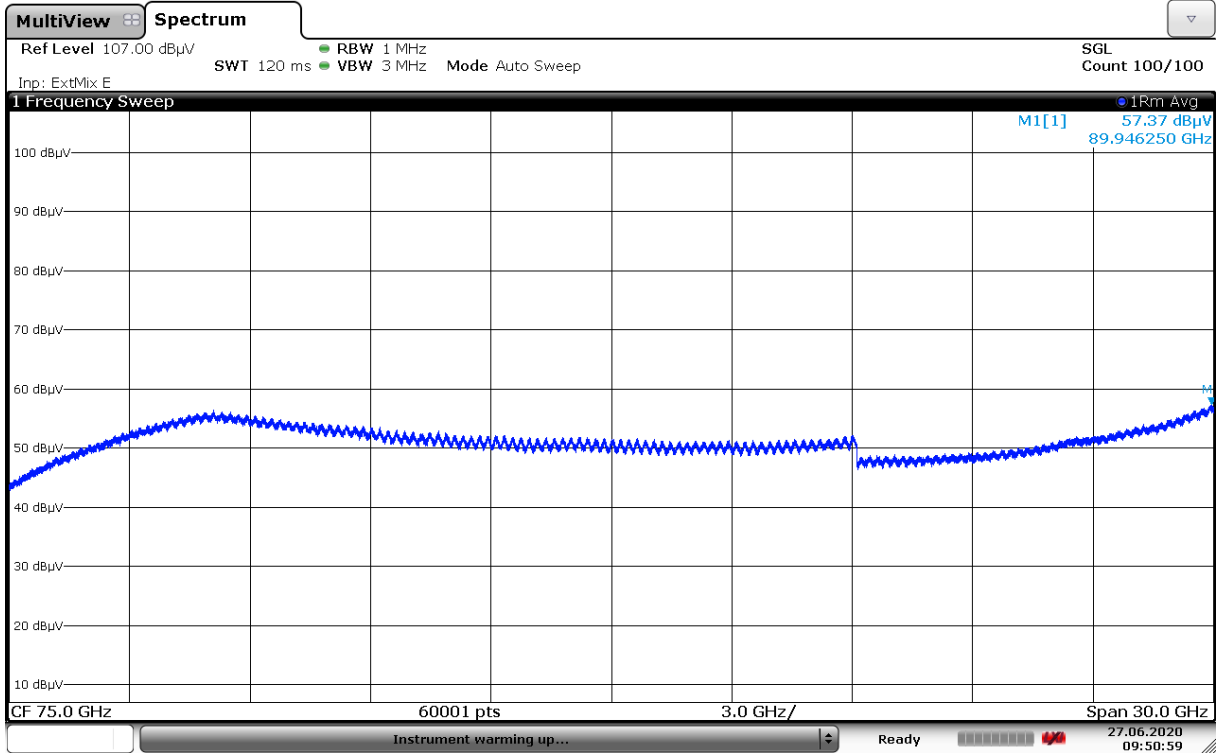

90 GHz ~ 140 GHz / 1cc + 1cc / Low / H / Non-Contiguous

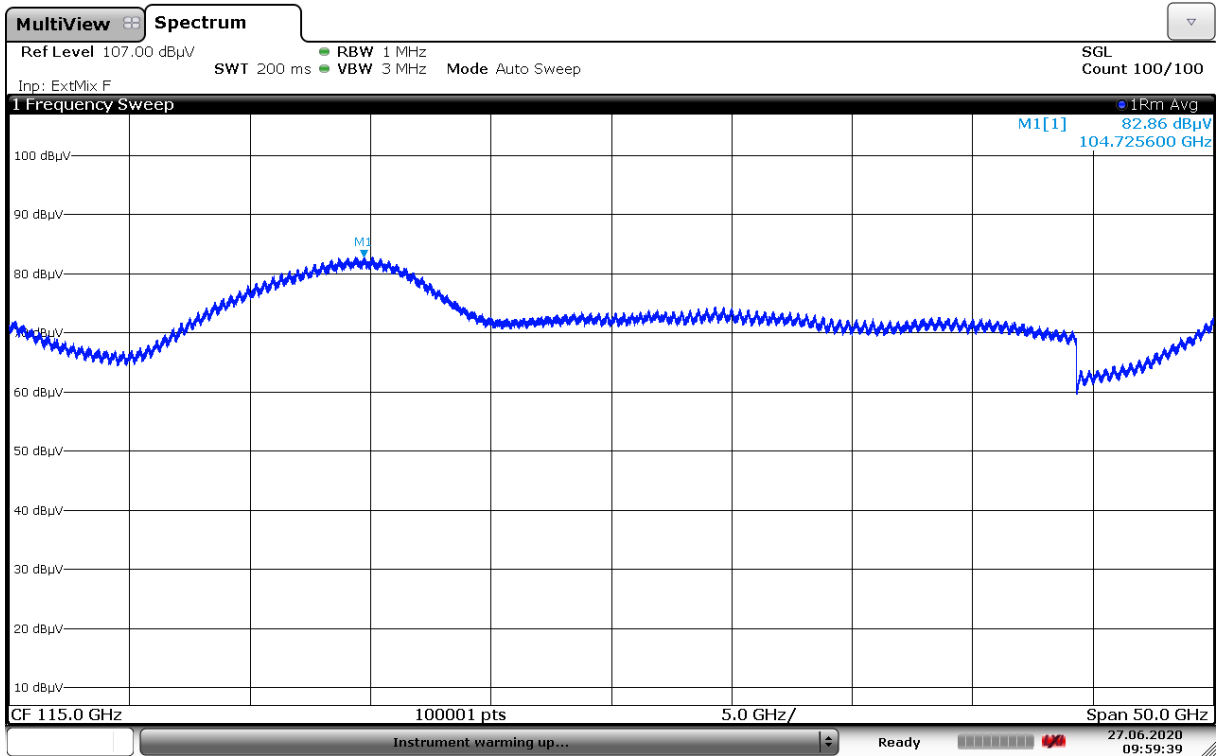

90 GHz ~ 140 GHz / 1cc + 1cc / Middle / H / Non-Contiguous

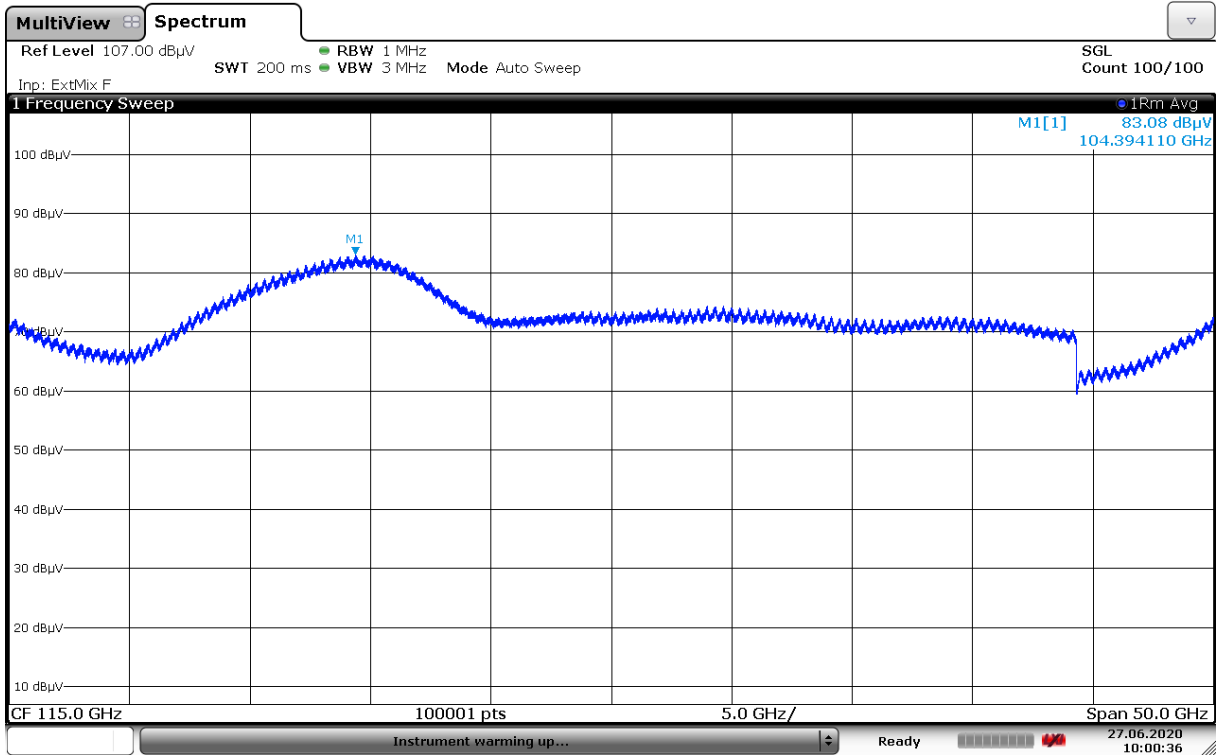

90 GHz ~ 140 GHz / 1cc + 1cc / High / H / Non-Contiguous

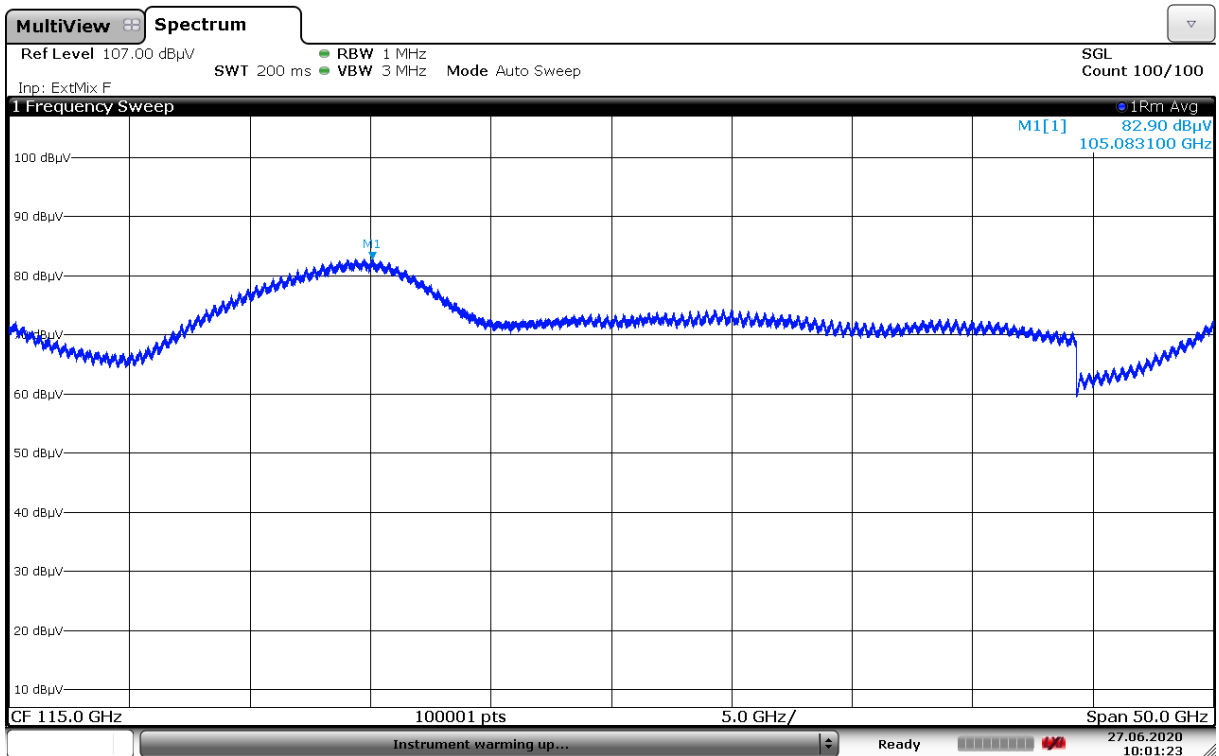

140 GHz ~ 180 GHz / 1cc + 1cc / Low / H / Non-Contiguous

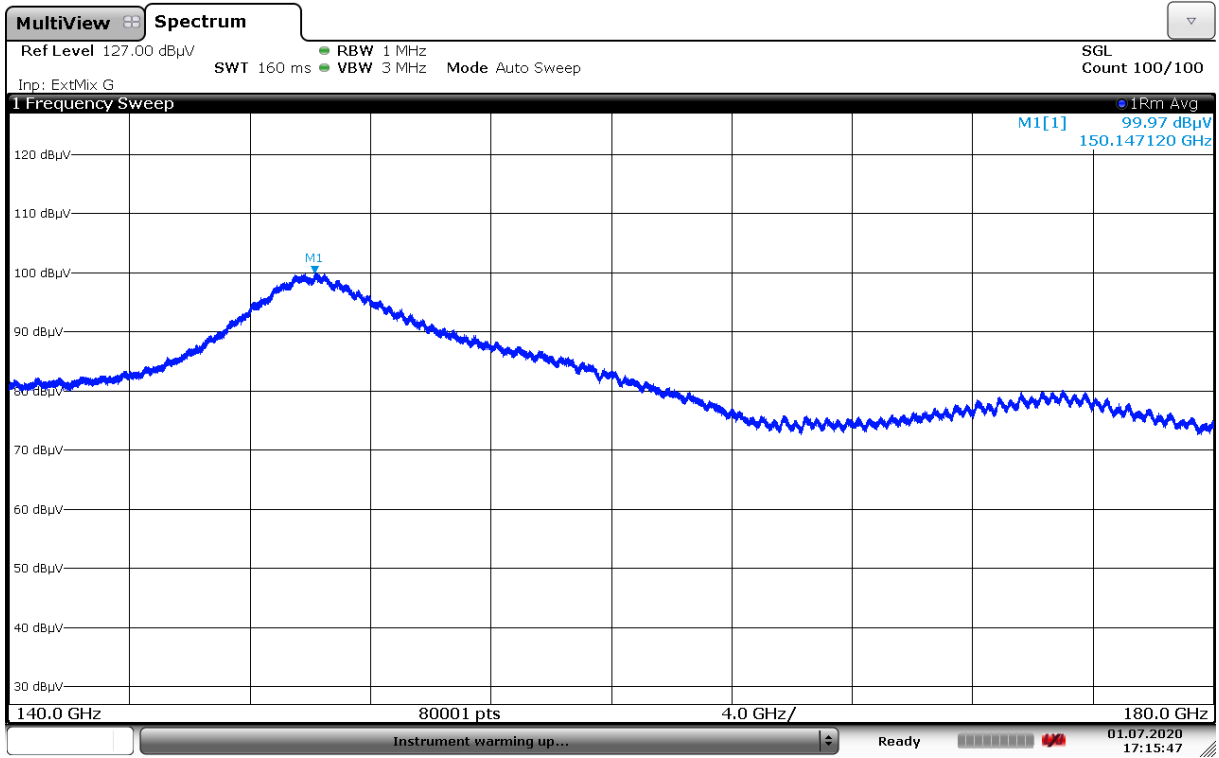

140 GHz ~ 180 GHz / 1cc + 1cc / Middle / H / Non-Contiguous

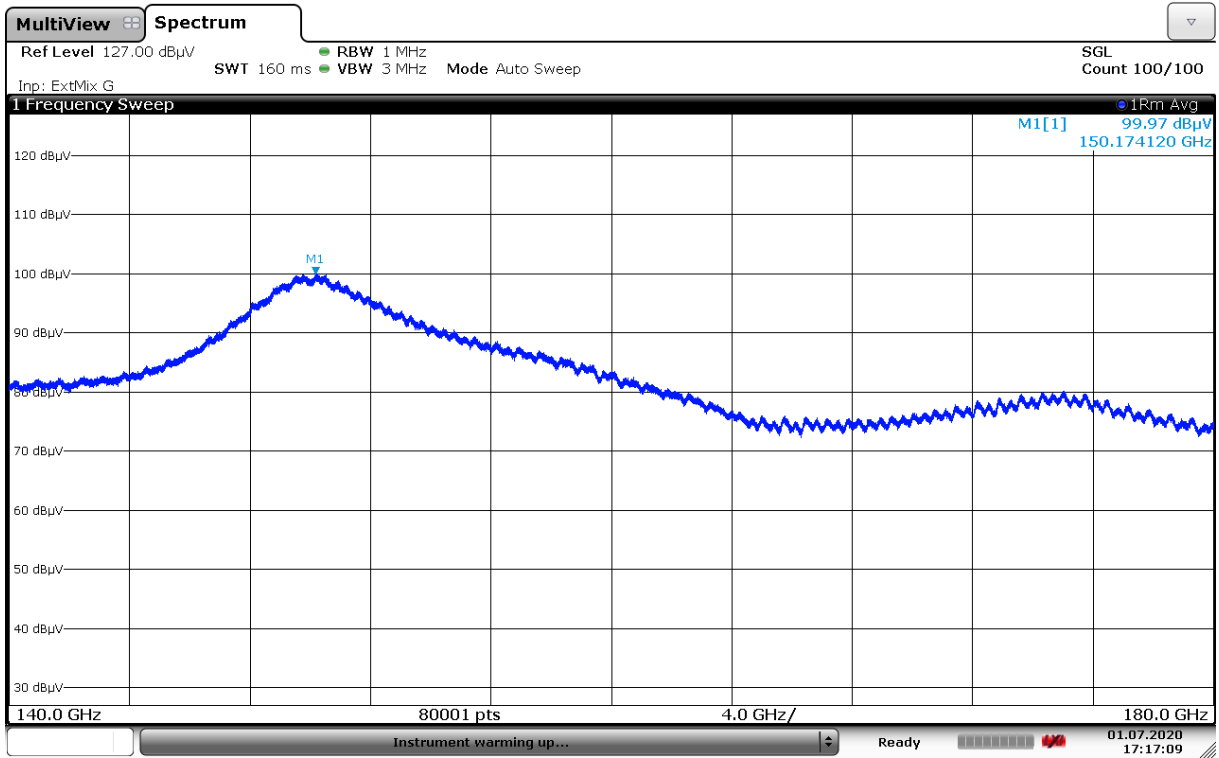

140 GHz ~ 180 GHz / 1cc + 1cc / High / H / Non-Contiguous

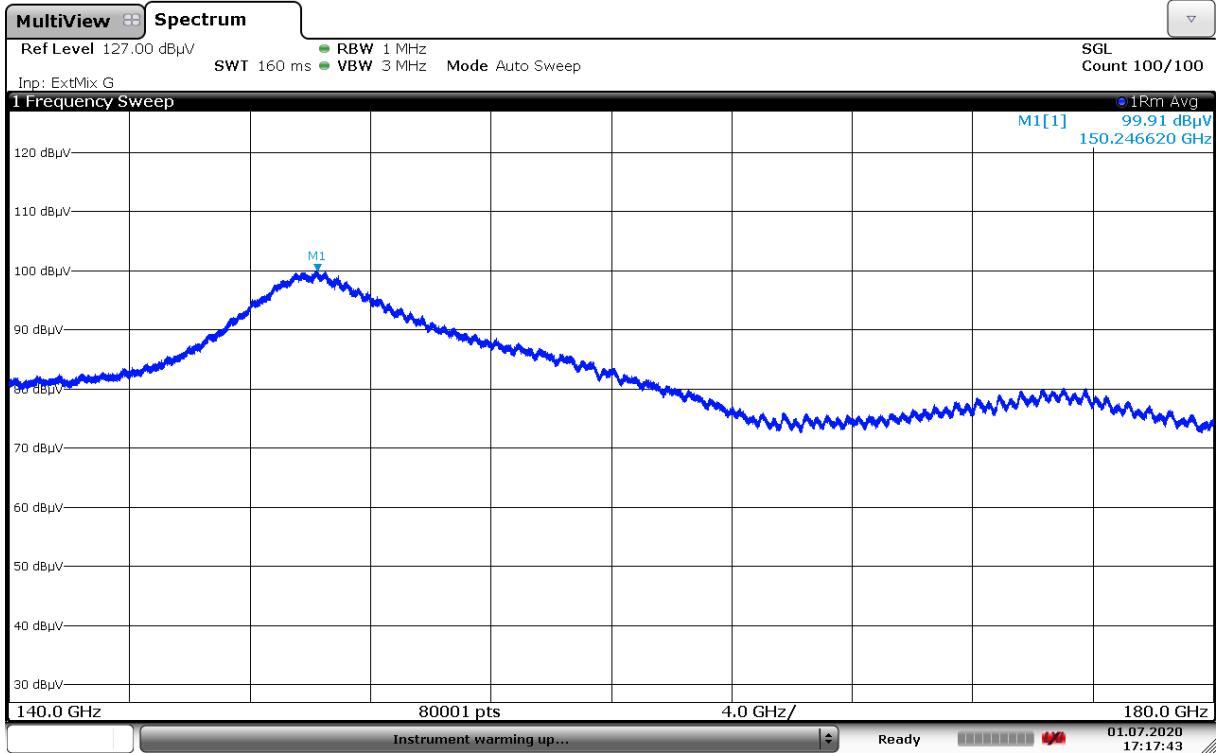

180 GHz ~ 200 GHz / 1cc + 1cc / Low / H / Non-Contiguous

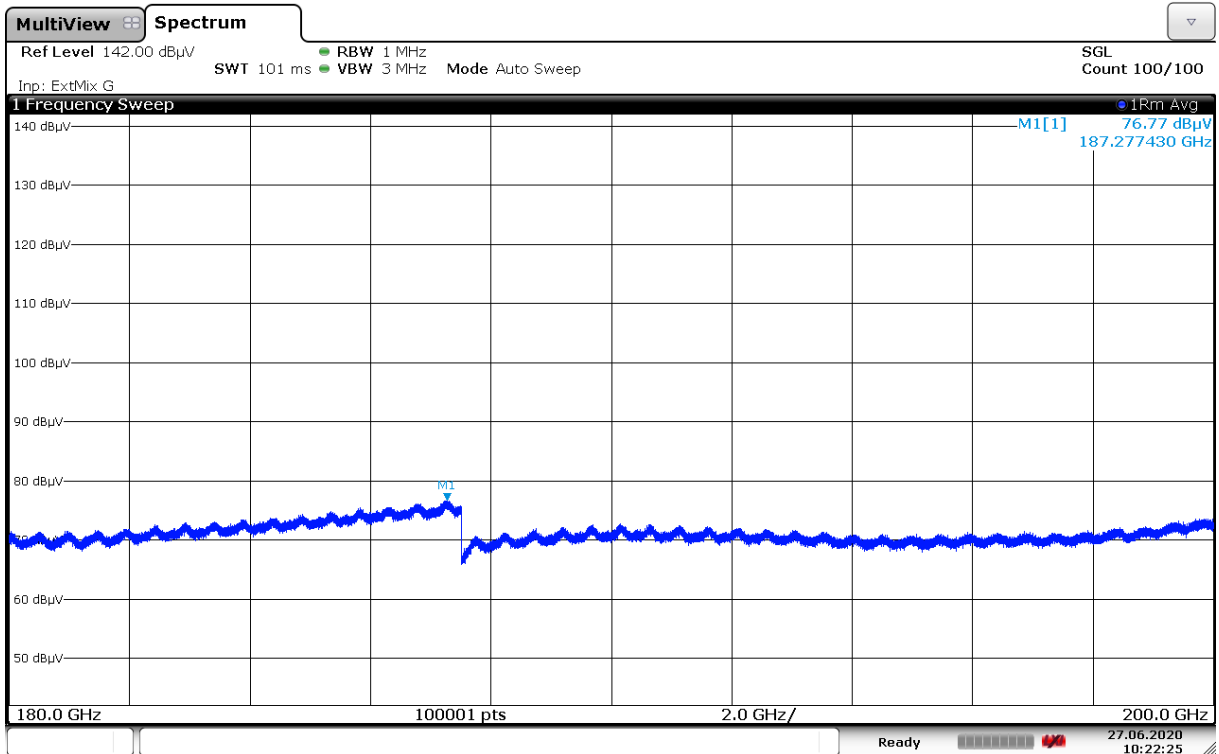

180 GHz ~ 200 GHz / 1cc + 1cc / Middle / H / Non-Contiguous

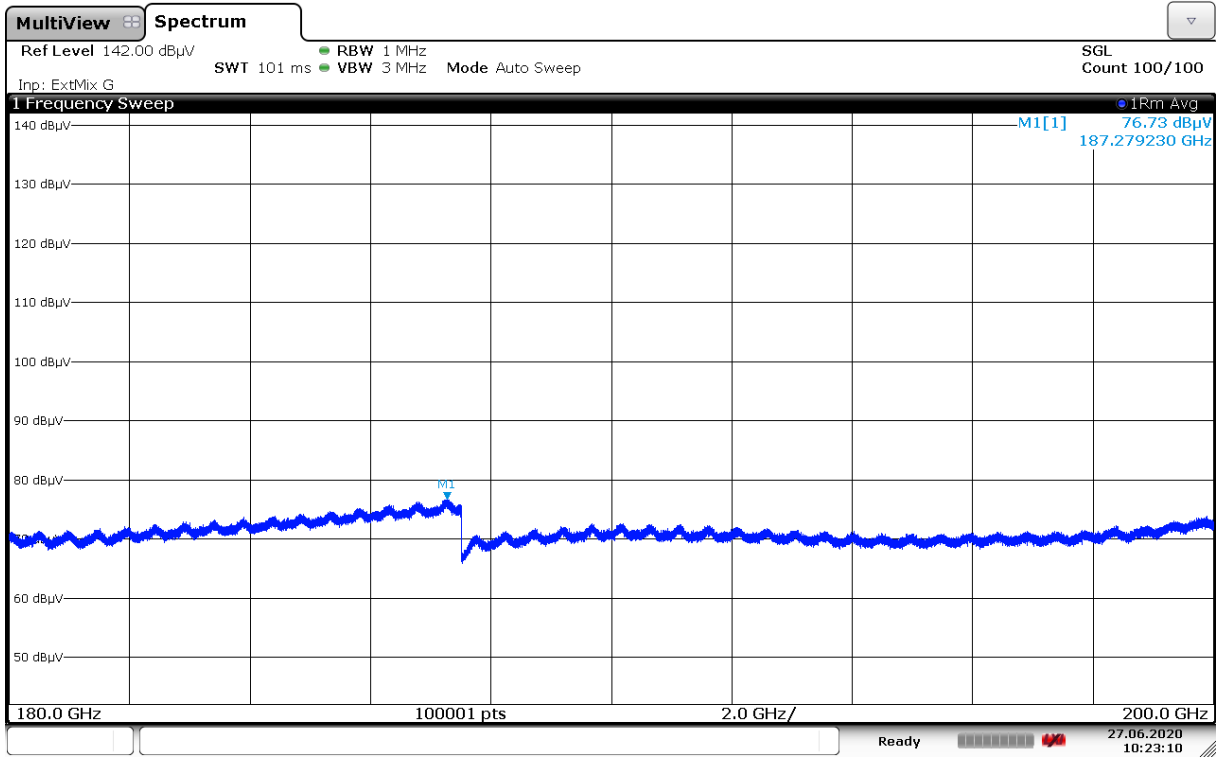

180 GHz ~ 200 GHz / 1cc + 1cc / High / H / Non-Contiguous

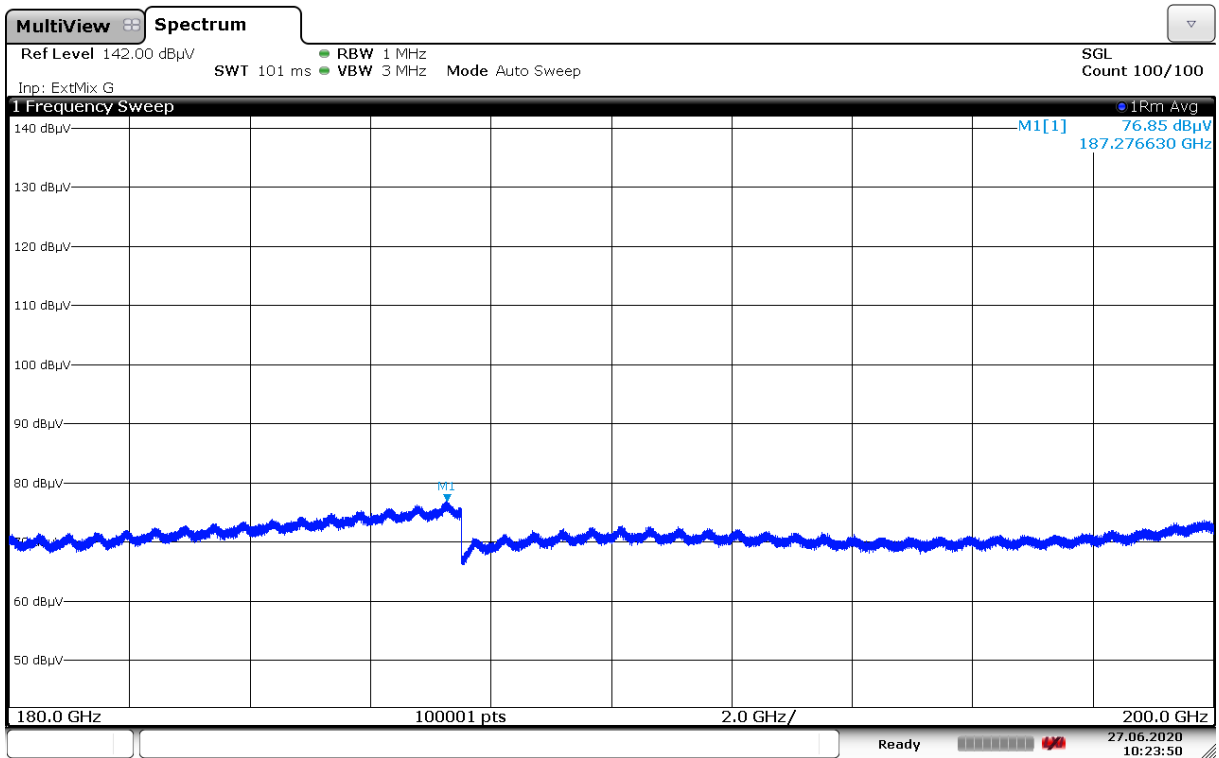

5.6. FREQUENCY STABILITY

FCC Rules

Test Requirements:

§ 2.1055 Measurements required: Frequency stability.

(a) The frequency stability shall be measured with variation of ambient temperature as follows:

- (1) From -30° to $+50^{\circ}$ centigrade for all equipment except that specified in paragraphs (a) (2) and (3) of this section.

Test Procedures:

The measurement is performed in accordance with Section 5.6.4 and 5.6.5 of ANSI C63.26.

5.6.4 Frequency stability over variations in temperature

- a) Supply the EUT with a nominal 60 Hz ac voltage, dc voltage, or install a new or fully charged battery in the EUT.
- b) If possible a dummy load should be connected to the EUT because an antenna near the metallic walls of an environmental test chamber could affect the output frequency of the EUT. If the EUT is equipped with a permanently attached, adjustable-length antenna, the EUT should be placed in the center of the chamber with the antenna adjusted to the shortest length possible.
- c) Turn on the EUT, and tune it to the center frequency of the operating band.
- d) Couple the transmitter output to the measuring instrument through a suitable attenuator and coaxial cable. If connection to the EUT output is not possible, make the measurement by connecting an antenna to the measuring instrument with a suitable length of coaxial cable and placing the measuring antenna near the EUT (e.g., 15 cm away).
NOTE—An instrument that has an adequate level of accuracy as specified by the procuring or regulatory authority is the recommended measuring instrument.
- e) Adjust the location of the measurement antenna and the controls on the measurement instrument to obtain a suitable signal level (i.e., a level that will not overload the measurement instrument, but is strong enough to allow measurement of the operating or fundamental frequency of the EUT). Adjust the detector bandwidth and span settings to achieve a resolution capable of accurate frequency measurements over the applicable frequency stability limits.
- f) Turn the EUT off, and place it inside the environmental temperature chamber. For devices that have oscillator heaters, energize only the heater circuit.
- g) Set the temperature control on the chamber to the highest temperature specified in the regulatory requirements for the type of device, and allow the oscillator heater and the chamber temperature to stabilize. Unless otherwise instructed by the regulatory authority, this temperature should be 50°C .
- h) While maintaining a constant temperature inside the environmental chamber, turn on the EUT and allow sufficient time for the EUT temperature to stabilize.
- i) Measure the frequency.
- j) Switch off the EUT, but do not switch off the oscillator heater.
- k) Lower the chamber temperature to the next level that is required by the standard and allow the temperature inside the chamber to stabilize. Unless otherwise instructed by the regulators, this temperature step should be 10°C .
- l) Repeat step h) through step k) down to the lowest specified temperature. Unless otherwise instructed by the regulators,

this temperature should be $-30\text{ }^{\circ}\text{C}$. When the frequency stability limit is stated as being sufficient such that the fundamental emissions stay within the authorized bands of operation, a reference point shall be established at the applicable unwanted emissions limit using a RBW equal to the RBW required by the unwanted emissions specification of the applicable regulatory standard. These reference points measured using the lowest and highest channel of operation shall be identified as f_L and f_H respectively. The worst-case frequency offset determined in the above methods shall be added or subtracted from the values of f_L and f_H and the resulting frequencies must remain within the band.

m) Omitted

5.6.5 Frequency stability when varying supply voltage

- a) Couple the transmitter output to the measuring instrument through a suitable attenuator and coaxial cable. If connection to the EUT output is not possible make the measurement by connecting an antenna to the measuring instrument with a suitable length of coaxial cable and placing the measuring antenna near the EUT (e.g., 15 cm away)
- b) Supply the EUT with nominal ac or dc voltage. The supply voltage shall be measured at the input to the cable normally provided with the equipment, or at the power supply terminals if cables are not normally provided. Effects on frequency of transmitter keying (except for broadcast transmitters) and any heating element cycling at the nominal supply voltage and at each extreme also shall be shown.
- c) Turn on the EUT, and couple its output to a frequency counter or other frequency-measuring instrument.
- d) Tune the EUT to the center frequency of the operating band. Adjust the location of the measurement antenna and the controls on the measurement instrument to obtain a suitable signal level (i.e., a level that will not overload the measurement instrument, but is strong enough to allow measurement of the operating or fundamental frequency of the EUT). Adjust the detector bandwidth and span settings to achieve a resolution capable of accurate frequency measurements over the applicable frequency stability limits.

NOTE—An instrument that has an adequate level of accuracy as specified by the procuring or regulatory authority is the recommended measuring instrument.

- e) Measure the frequency.
- f) Unless otherwise specified, vary primary supply voltage from 85% to 115% of the nominal value for other than hand carried battery equipment.
- g) For hand carried, battery powered equipment, reduce the primary ac or dc supply voltage to the battery operating end point, which shall be specified by the manufacturer.
- h) Repeat the frequency measurement.

NOTE—For band-edge compliance, it can be required to make these measurements at the low and high channel of the operating band.

Note:

- 1) The results of the frequency stability test shown above the frequency deviation measured values are very small and similar trend for each path, so we are attached only the worst case data.
- 2) Test signal is CW signal for frequency stability.

Test Results:

Reference: Voltage = (100 ~ 240) VAC at 20°C, Frequency = 38.50 GHz

Voltage (%)	Temp. (°C)	Frequency (Hz)	Frequency Error (Hz)	Deviation (Hz)	ppm
100%	+20(Ref)	38500 000 010	9.959	0.000	0.00000
	-30	38500 000 005	4.825	-5.134	-0.00013
	-20	38500 000 007	6.859	-3.100	-0.00008
	-10	38500 000 008	7.533	-2.426	-0.00006
	0	38500 000 009	9.027	-0.932	-0.00002
	+10	38500 000 007	6.881	-3.078	-0.00008
	+30	38500 000 008	8.416	-1.543	-0.00004
	+40	38500 000 009	8.640	-1.319	-0.00003
	+50	38500 000 002	2.237	-7.722	-0.00020
	+55	38500 000 000	0.447	-9.512	-0.00025
115%	+20	38500 000 005	4.658	-5.301	-0.00014
85%	+20	38500 000 010	9.959	0.000	0.00000

6. MIXER VERIFICATION CERTIFICATE & CHECK

열람용
This certificate may not be reproduced other than in full except with permission of the issuing laboratory.

교정성적서
CALIBRATION CERTIFICATE
경기도 이천시 마장면 서이천로 578번길 74
TEL : 031-645-6900, FAX : 031-645-6969



성적서발급번호(Certificate No) : IC-2019-61925
교정번호(Calibration No) : C-2019-072381

페이지(page) : 1 of 3

- 1. 의뢰자 (Client)**
 - 기관명 (Name) : (주)에이치시티
 - 주소 (Address) : 경기도 이천시 마장면 서이천로 578번길 74
- 2. 측정기 (Calibration Subject)**
 - ◇ 등록번호 : 288236
 - 기기명 (Description) : WR-08 HARMONIC MIXER
 - 제작회사 및 형식(Manufacturer and Model Name) : OML / M08HWD
 - 기기번호 (Serial Number) : 160419-1
- 3. 교정일자 (Date of Calibration)** : 2019.09.09 차기교정예정일자 : 2020.09.09
(The due date of next Calibration)
- 4. 교정환경 (Environment)**
 - 온도(Temperature) : (23.2 ± 0.4) °C 습도(Humidity) : (50 ± 2) % R.H.
 - 교정장소 (Location) : 고정표준실(Permanent Calibration Lab)
- 5. 측정표준의 소급성 (Traceability)** ◇Field code : 40641(RF SPECTRUM ANALYZER)
교정방법 및 소급성 서술 (Calibration method and/or brief description)
상기 기기는 고주파 스펙트럼 분석기의 교정절차(HCT-CS-125-40641)에 따라 국가측정표준기관으로부터 측정의 소급성이 확보된 아래의 표준장비를 이용하여 교정 되었음.

교정에 사용한 표준장비 명세 (List of used standards/specifications)

기기명 (Description)	제작회사 및 형식 (Manufacturer and Model Name)	기기번호 (Serial Number)	차기교정예정일자 (The due date of next Calibration)	교정기관 (Calibration laboratory)
EXG ANALOG SIGNAL GENERATOR	KEYSIGHT N5173B	MY53270544	2019/10/04	(주)에이치시티
EPM SERIES POWER METER	AGILENT E4419B	G842420565	2019/11/01	(주)에이치시티
POWER SENSOR	KEYSIGHT W8486A	MY56370005	2019/12/27	Keysight Technologies
WR-08 MULTIPLIER SOURCE MODULE	OML S08MS-A	164019-1	2020/09/09	(주)에이치시티

- 6. 교정결과 (Calibration result)** : 교정결과 참조 (Refer to attachment)
- 7. 측정불확도 (Measurement uncertainty)** : 교정결과 참조 (Refer to attachment)
신뢰수준 약 95 %, k = 2 (Confidence level about 95 %, k = 2)

확인 (affirmation)	작성사 (Measurements performed by)	승인자 (Approved by)
	성명 (Name) 박민지	직위 (Title) 기술책임자(Technical Cal. Manager) (정) 이승찬 성명 (Name) 이승찬

위 성적서는 국제시험기관인정협력체(International Laboratory Accreditation Cooperation) 상호인정협정(Mutual Recognition Arrangement)에 서명한 한국인정기구(KOLAS)로부터 공인 받은 분야의 교정결과입니다.

2019. 09. 11
한국인정기구 인정 (주)에이치시티 대표이사
Accredited by KOLAS, Republic of KOREA President, HCT Co., Ltd.



(주) 이 성적서는 측정기의 정밀정확도에 영향을 미치는 요소(과부하, 온도, 습도 등)의 급격한 변화가 발생한 경우에는 무효가 됩니다.

※ 고객전용사이트(http://www.callab.co.kr)에서 성적서의 진위여부 확인이 가능합니다.

※ 성적서의 원본은 상단에 HCT로로그램이 들어간 워터마크 방지막 용지에 인쇄되어 발급되며, 원본 복사시에는 복사본이라는 표시가 처리됩니다.

F-02P-02-008 (Rev.02)

교정결과 CALIBRATION RESULT



성적서발급번호(Certificate No) : IC-2019-61925
교 정 번 호(Calibration No) : C-2019-072381

페이지(page) : 2 of 3

1. Conversion Loss Graph

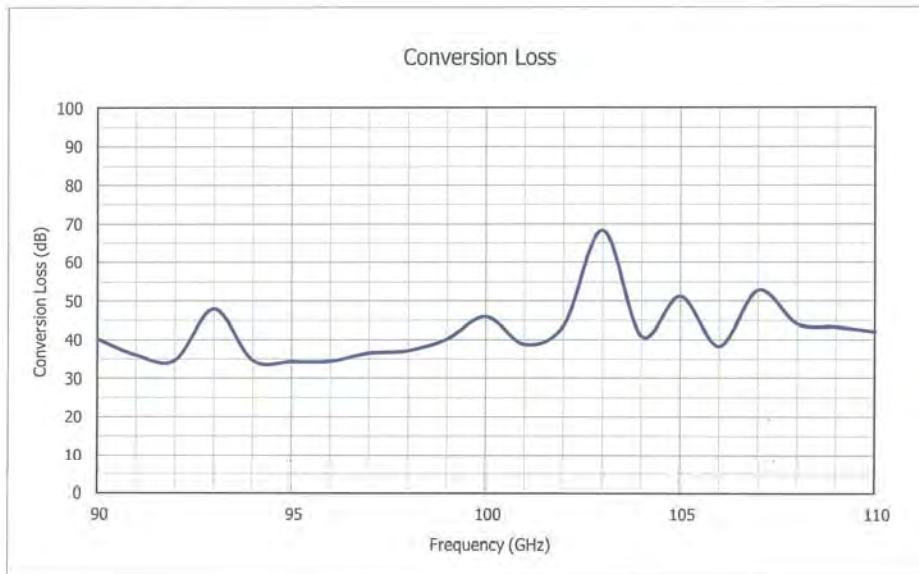

Note 1) R&S FSW (SN 104544)와 함께 교정된 결과임

Note 2) 측정 조건 : RF = -25 dBm, Harmonic Order = 10, L.O. Level = 17 dBm, Bias Value = 0.01 mA

F-02P-02-008 (Rev.02)

교 정 결 과

CALIBRATION RESULT



성적서발급번호(Certificate No) : IC-2019-61925

교 정 번 호(Calibration No) : C-2019-072381

페이지(page) : 3 of 3

2. Conversion Loss Data

Frequency (GHz)	Conversion Loss (dB)	Measurement Uncertainty (dB)	Frequency (GHz)	Conversion Loss (dB)	Measurement Uncertainty (dB)
90.0	40.23	0.89	101.0	38.81	0.89
91.0	35.98	0.89	102.0	43.65	0.89
92.0	34.65	0.89	103.0	68.37	0.89
93.0	47.96	0.89	104.0	40.88	0.89
94.0	34.60	0.89	105.0	51.24	0.89
95.0	34.29	0.89	106.0	38.26	0.89
96.0	34.40	0.89	107.0	52.83	0.89
97.0	36.50	0.89	108.0	44.13	0.89
98.0	37.13	0.89	109.0	43.30	0.89
99.0	40.18	0.89	110.0	42.01	0.89
100.0	45.99	0.89	-	-	-

끝

열람용

 This certificate may not be reproduced
other than in full except with
permission of the issuing laboratory.

점검성적서
CHECK REPORTS

 경기도 이천시 마장면 서이천로 578번길 74
Tel : 031-645-8900, Fax : 031-645-8969

 성적서발급번호(Certificate No) : IC-2019-63581
점검번호(Checks No) : C-2019-074399

페이지(page) : 1 of 3

1. 의뢰자 (Client)

 - 기관명 (Name) : (주)에이치시티
- 주소 (Address) : 경기도 이천시 마장면 서이천로 578번길 74

2. 측정기 (Check Subject)

◇ 등록번호 : 366196

 - 기기명 (Description) : WR-08 HARMONIC MIXER
- 제작회사 및 형식 (Manufacturer and Model Name) : OML / M08HWD
- 기기번호 (Serial Number) : 160419-1

3. 점검일자 (Date of Check)

: 2019.09.09

4. 점검환경 (Environment Conditions)

 - 온도(Temperature) : (23.2 ± 0.4) °C - 습도(Humidity) : (50 ± 2) % R.H.
- 점검장소 (Location) : 고정표준실(Permanent Calibration Lab)

5. 측정표준의 소급성 (Traceability)
점검방법 및 소급성 서술 (Check method and/or brief description)

상기 기기는 고주파 스펙트럼 분석기의 고정절차(HCT-CS-125-40641)에 따라 국가측정표준기관으로부터 측정의 소급성이 확보된 아래의 아래의 표준장비와 자체 점검된 장비를 이용하여 점검 되었음.

점검에 사용한 표준장비 명세 (List of used standards/specifications)

기기명 (Description)	제작회사 및 형식 (Manufacturer and Model Name)	기기번호 (Serial Number)	차기교정에정일자 (The due date of next Calibration)	교정기관 (Calibration laboratory)
EXG ANALOG SIGNAL GENERATOR	KEYSIGHT	MYS3270544	2019/10/04	(주)에이치시티
	N5173B			
ERICKSON POWER METER	VDI	394V	점검	(주)에이치시티
	PM5			
WR-08 MULTIPLIER SOURCE MODULE	OML	160419-1	점검	(주)에이치시티
	S08MS-A			

6. 점검결과 (Check result)

: 점검결과 참조 (Refer to attachment)

확 인 (affirmation)	작성자 (checks performed by)		승인자 (Approved by)	
	성명 (Name) : 박민지		직위 (Title) 기술책임자(Technical Cal. Manager) (성명) 성명 (Name) 이승찬	

위 점검결과는 국가교정기관 제정제도 운영요령 제41조 규정에 의거하여 국가측정표준과 소급성이 확립된 측정기로써 점검한 성적서임을 증명합니다.

2019. 09. 11

 (주)에이치시티 대표이사
President, HCT Co., Ltd.

(본) 이 성적서는 측정기의 정밀정확도에 영향을 미치는 요소(과부하, 온도, 습도 등)의 급격한 변화가 발생한 경우에는 무효가 됩니다.

F-02P-02-010 (Rev.01)

점검결과 CHECK RESULT

성적서발급번호(Certificate No) : IC-2019-63581
 점검번호(Checks No) : C-2019-074399

페이지(page) : 2 of 3

1. Conversion Loss Graph

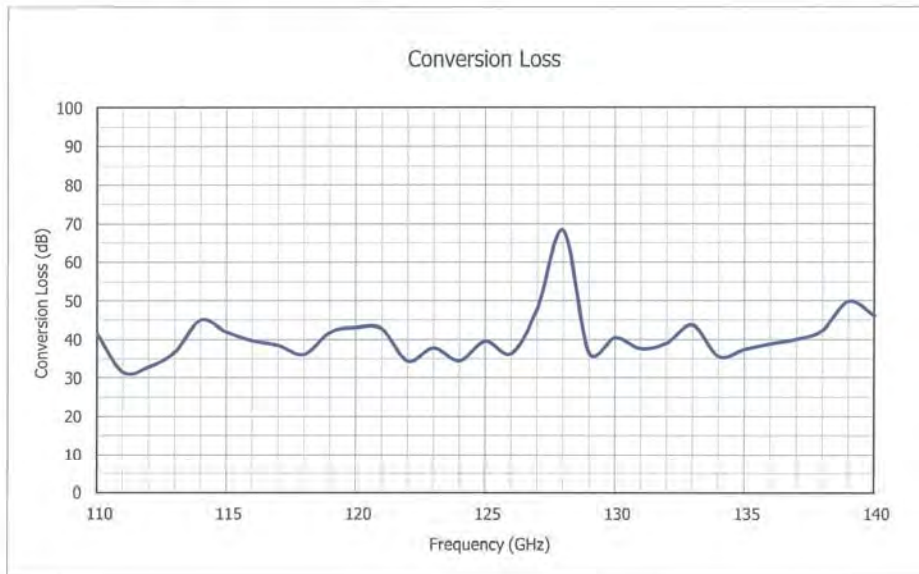

Note 1) R&S FSW (SN 104544)와 함께 고정된 결과임

Note 2) 측정 조건 : RF = -25 dBm, Harmonic Order = 10, L.O. Level = 17 dBm, Bias Value = 0.01 mA

Note 3) 110 GHz 초과 대역의 전력에 대해 국제적인 소급표준이 없으므로 HCT에서 자체적으로 소급된 기준기로 점검되었음.

- In the absence of power standards above 110 GHz, power measurements above 110 GHz are to confirm operation functionality and traceable only to HCT.

F-02P-02-010 (Rev.01)

점검결과

CHECK RESULT

성적서발급번호(Certificate No) : IC-2019-63581

페이지(page) : 3 of 3

점검번호(Checks No) : C-2019-074399

2. Conversion Loss Data

Frequency (GHz)	Conversion Loss (dB)	Measurement Uncertainty (dB)	Frequency (GHz)	Conversion Loss (dB)	Measurement Uncertainty (dB)
110.0	41.6	0.82	126.0	36.3	0.82
111.0	31.5	0.82	127.0	47.9	0.82
112.0	32.8	0.82	128.0	68.3	0.82
113.0	36.6	0.82	129.0	36.5	0.82
114.0	44.9	0.82	130.0	40.5	0.82
115.0	41.9	0.82	131.0	37.6	0.82
116.0	39.7	0.82	132.0	39.0	0.82
117.0	38.4	0.82	133.0	43.7	0.82
118.0	36.1	0.82	134.0	35.5	0.82
119.0	41.8	0.82	135.0	37.3	0.82
120.0	43.1	0.82	136.0	38.9	0.82
121.0	42.8	0.82	137.0	40.0	0.82
122.0	34.3	0.82	138.0	42.3	0.82
123.0	37.8	0.82	139.0	49.8	0.82
124.0	34.4	0.82	140.0	46.1	0.82
125.0	39.6	0.82	-	-	-

끝.

열람용
This certificate may not be reproduced other than in full except with permission of the issuing laboratory.

교정성적서 CALIBRATION CERTIFICATE

경기도 이천시 마장면 서이천로 578번길 74
TEL : 031-645-6900, FAX : 031-645-6969



성적서발급번호(Certificate No) : IC-2019-61921
교정번호(Calibration No) : C-2019-072377

페이지(page) : 1 of 3

- 1. 의뢰자 (Client)**
 - 기관명 (Name) : (주)에이치시티
 - 주소 (Address) : 경기도 이천시 마장면 서이천로 578번길 74
- 2. 측정기 (Calibration Subject)**
 - ◇ 등록번호 : 288235
 - 기기명 (Description) : WR-12 HARMONIC MIXER
 - 제작회사 및 형식(Manufacturer and Model Name) : OML / M12HWD
 - 기기번호 (Serial Number) : 160419-1
- 3. 교정일자 (Date of Calibration) : 2019.09.09** **차기교정예정일자 : 2020.09.09**
(The due date of next Calibration)
- 4. 교정환경 (Environment)**
 - 온도(Temperature) : (23.2 ± 0.4) °C - 습도(Humidity) : (50 ± 2) % R.H.
 - 교정장소 (Location) : 고정표준실(Permanent Calibration Lab)
- 5. 측정표준의 소급성 (Traceability) ◇Field code : 40641(RF SPECTRUM ANALYZER)**
교정방법 및 소급성 서술 (Calibration method and/or brief description)
상기 기기는 고주파 스펙트럼 분석기의 교정절차(HCT-CS-125-40641)에 따라 국가측정표준기관으로부터 측정의 소급성이 확보된 아래의 표준장비를 이용하여 교정 되었음.

교정에 사용한 표준장비 명세 (List of used standards/specifications)

기기명 (Description)	제작회사 및 형식 (Manufacturer and Model Name)	기기번호 (Serial Number)	차기교정예정일자 (The due date of next Calibration)	교정기관 (Calibration laboratory)
EXG ANALOG SIGNAL GENERATOR	KEYSIGHT N5173B	MY53270544	2019/10/04	(주)에이치시티
	AGILENT E4419B			
EPM SERIES POWER METER	KEYSIGHT V8486A	GB42420565	2019/11/01	(주)에이치시티
POWER SENSOR	KEYSIGHT V8486A	MY56330017	2019/12/27	Keysight Technologies
	KEYSIGHT W8486A			
POWER SENSOR	KEYSIGHT W8486A	MY56370005	2019/12/27	Keysight Technologies
	OML S12MS-A			
WR-12 MULTIPLIER SOURCE MODULE	OML S12MS-A	160419-1	2020/09/09	(주)에이치시티

- 6. 교정결과 (Calibration result) : 교정결과 참조 (Refer to attachment)**
- 7. 측정불확도 (Measurement uncertainty) : 교정결과 참조 (Refer to attachment)**
신뢰수준 약 95%, k = 2 (Confidence level about 95%, k = 2)

확 인 (affirmation)	작성자 (Measurements performed by)	승인자 (Approved by)
	성명 (Name) 박민지	직위 (Title) 기술책임자(Technical Cal. Manager) (경) 이 승 찬

위 성적서는 국제시험기관인정협력체(International Laboratory Accreditation Cooperation) 상호인정협정(Mutual Recognition Arrangement)에 서명한 한국인정기구(KOLAS)로부터 공인 받은 분야의 교정결과입니다.

2019. 09. 11

한국인정기구 인정
Accredited by KOLAS, Republic of KOREA

(주)에이치시티 대표이사
President, HCT Co., Ltd.



※ 이 성적서는 측정기의 정밀정확도에 영향을 미치는 요소(과부하, 온도, 습도 등)의 급격한 변화가 발생한 경우에는 무효가 됩니다.
※ 고객전용사이트(http://www.callab.co.kr)에서 성적서의 진위여부 확인이 가능합니다.
※ 성적서의 원본은 상단에 HCT로고그램이 들어간 위변조 방지 용지에 인쇄되어 발급되며, 오픈 복사시에는 복사본이라는 표시가 처리됩니다.

교정결과 CALIBRATION RESULT



성적서발급번호(Certificate No) : IC-2019-61921

교정번호(Calibration No) : C-2019-072377

페이지(page) : 2 of 3

1. Conversion Loss Graph

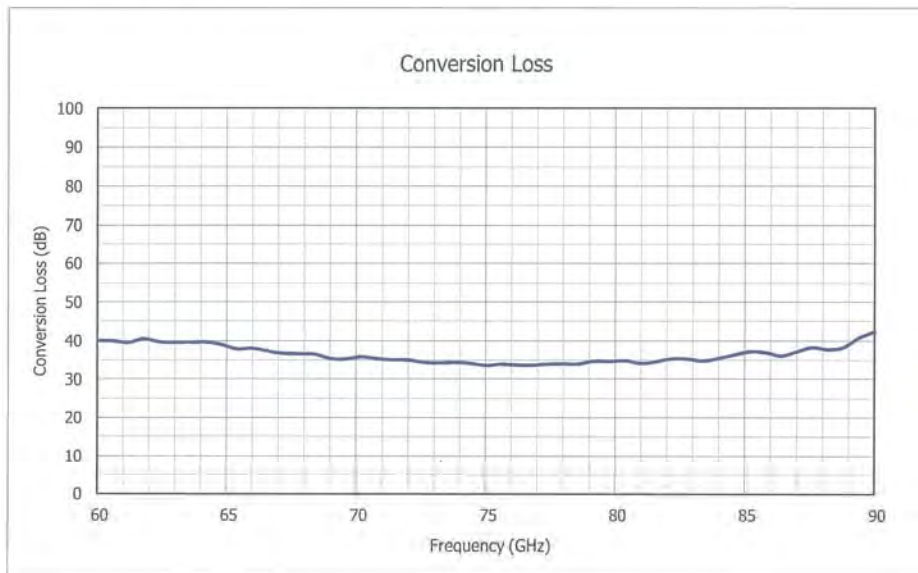

Note 1) R&S FSW (SN 104544)와 함께 교정된 결과임

Note 2) 측정 조건 : RF = -25 dBm, Harmonic Order = 6, L.O. Level = 17 dBm, Bias Value = 4.98 mA

F-02P-02-008 (Rev.02)

교 정 결 과

CALIBRATION RESULT



성적서발급번호(Certificate No) : IC-2019-61921

교 정 번 호(Calibration No) : C-2019-072377

페이지(page) : 3 of 3

2. Conversion Loss Data

Frequency (GHz)	Conversion Loss (dB)	Measurement Uncertainty (dB)	Frequency (GHz)	Conversion Loss (dB)	Measurement Uncertainty (dB)
60.0	40.07	0.89	75.6	33.85	0.82
60.6	40.00	0.89	76.2	33.65	0.82
61.2	39.55	0.89	76.8	33.61	0.82
61.8	40.54	0.89	77.4	33.90	0.82
62.4	39.71	0.89	78.0	33.98	0.82
63.0	39.59	0.90	78.6	33.93	0.82
63.6	39.58	0.89	79.2	34.68	0.82
64.2	39.65	0.89	79.8	34.61	0.82
64.8	39.03	0.89	80.4	34.80	0.82
65.4	37.86	0.89	81.0	34.11	0.82
66.0	38.00	0.89	81.6	34.57	0.82
66.6	37.24	0.90	82.2	35.33	0.82
67.2	36.69	0.89	82.8	35.24	0.82
67.8	36.59	0.89	83.4	34.76	0.82
68.4	36.48	0.89	84.0	35.48	0.82
69.0	35.31	0.89	84.6	36.37	0.82
69.6	35.21	0.89	85.2	37.19	0.82
70.2	35.77	0.89	85.8	36.94	0.82
70.8	35.29	0.89	86.4	36.06	0.82
71.4	35.00	0.89	87.0	37.18	0.82
72.0	34.94	0.89	87.6	38.26	0.82
72.6	34.36	0.89	88.2	37.72	0.82
73.2	34.21	0.89	88.8	38.28	0.82
73.8	34.32	0.89	89.4	40.81	0.82
74.4	34.12	0.89	90.0	42.41	0.82
75.0	33.56	0.82	-	-	-

끝

F-02P-02-008 (Rev.02)

열람용
This certificate may not be reproduced
other than in full except with
permission of the issuing laboratory.

교정성적서 CALIBRATION CERTIFICATE

경기도 이천시 마장면 서이천로 578번길 74
TEL : 031-645-6900, FAX : 031-645-6969



성적서발급번호(Certificate No) : IC-2019-61926
교정번호(Calibration No) : C-2019-072382

페이지(page) : 1 of 3

- 1. 의뢰자 (Client)**
- 기관명 (Name) : (주)에이치시티
- 주소 (Address) : 경기도 이천시 마장면 서이천로 578번길 74
- 2. 측정기 (Calibration Subject)** ◇ 등록번호 : 288234
- 기기명 (Description) : WR-19 HARMONIC MIXER
- 제작회사 및 형식 (Manufacturer and Model Name) : OML / M19HWD
- 기기번호 (Serial Number) : 160429-1
- 3. 교정일자 (Date of Calibration)** : 2019.09.09 차기교정예정일자 : 2020.09.09
(The due date of next Calibration)
- 4. 교정환경 (Environment)**
- 온도(Temperature) : (23.2 ± 0.4) °C - 습도(Humidity) : (50 ± 2) % R.H.
- 교정장소 (Location) : 고정표준실(Permanent Calibration Lab)
- 5. 측정표준의 소급성 (Traceability)** ◇ Field code : 40641(RF SPECTRUM ANALYZER)
교정방법 및 소급성 서술 (Calibration method and/or brief description)
상기 기기는 고주파 스펙트럼 분석기의 교정절차(HCT-CS-125-40641)에 따라 국가측정표준기관으로부터 측정의 소급성이 확보된 아래의 표준장비를 이용하여 교정 되었음.

교정에 사용한 표준장비 명세 (List of used standards/specifications)

기기명 (Description)	제작회사 및 형식 (Manufacturer and Model Name)	기기번호 (Serial Number)	차기교정예정일자 (The due date of next Calibration)	교정기관 (Calibration laboratory)
EXG ANALOG SIGNAL GENERATOR	KEYSIGHT N5173B	MY53270544	2019/10/04	(주)에이치시티
	AGILENT E4419B			
EPM SERIES POWER METER	AGILENT 8487A	MY41092450	2020/01/22	Keysight Technologies
	KEYSIGHT V8486A			
POWER SENSOR	OML S19MS-A	160516-1	2020/09/09	(주)에이치시티

- 6. 교정결과 (Calibration result)** : 교정결과 참조 (Refer to attachment)
- 7. 측정불확도 (Measurement uncertainty)** : 교정결과 참조 (Refer to attachment)
신뢰수준 약 95%, k = 2 (Confidence level about 95%, k = 2)

확 인 (affirmation)	작성자 (Measurements performed by) 성명 (Name) 박민지	승인자 (Approved by) 직위 (Title) 기술책임자(Technical Cal. Manager) (명)
		성명 (Name) 이승찬

위 성적서는 국제시험기관 인정협력체(International Laboratory Accreditation Cooperation) 상호인정협정(Mutual Recognition Arrangement)에 서명한 한국인정기구(KOLAS)로부터 공인 받은 분야의 교정결과입니다.

2019. 09. 11
한국인정기구 인정 (주)에이치시티 대표이사
Accredited by KOLAS, Republic of KOREA President, HCT Co., Ltd.



※ 이 성적서는 측정기의 정밀정확도에 영향을 미치는 요소(과부하, 온도, 습도 등)의 급격한 변화가 발생한 경우에는 무효가 됩니다.
※ 고객전용사이트(<http://www.callab.co.kr>)에서 성적서의 진위여부 확인이 가능합니다.
※ 성적서의 원본은 상단에 HCT로고그램이 들어간 워터마크 방지 용지에 인쇄되어 발급되며, 원본 복사시에는 복사본이라는 표시가 처리됩니다.

교정결과 CALIBRATION RESULT



성적서발급번호(Certificate No) : IC-2019-61926

교정번호(Calibration No) : C-2019-072382

페이지(page) : 2 of 3

1. Conversion Loss Graph

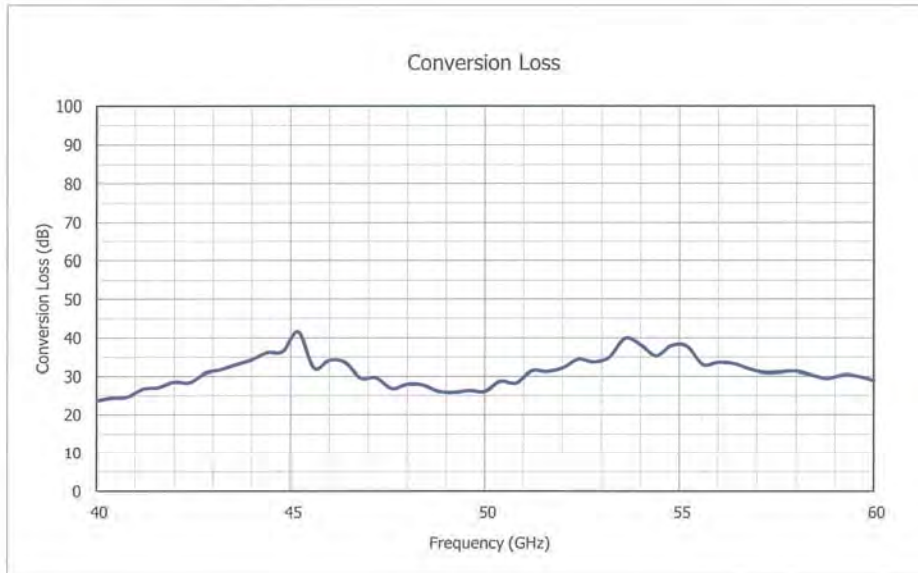

Note 1) R&S FSW (SN 104544)와 함께 교정된 결과임

Note 2) 측정 조건 : RF = -25 dBm, Harmonic Order = 4, L.O. Level = 17 dBm, Bias Value = 5.70 mA

F-02P-02-008 (Rev.02)

교 정 결 과

CALIBRATION RESULT



심적서발급번호(Certificate No) : IC-2019-61926

교 정 번 호(Calibration No) : C-2019-072382

페이지(page) : 3 of 3

2. Conversion Loss Data

Frequency (GHz)	Conversion Loss (dB)	Measurement Uncertainty (dB)	Frequency (GHz)	Conversion Loss (dB)	Measurement Uncertainty (dB)
40.0	23.65	0.82	50.4	28.72	0.82
40.4	24.34	0.82	50.8	28.23	0.82
40.8	24.60	0.82	51.2	31.34	0.82
41.2	26.66	0.82	51.6	31.20	0.82
41.6	27.09	0.82	52.0	32.06	0.82
42.0	28.53	0.82	52.4	34.37	0.82
42.4	28.34	0.82	52.8	33.68	0.82
42.8	30.76	0.82	53.2	34.90	0.82
43.2	31.68	0.82	53.6	39.85	0.82
43.6	32.96	0.82	54.0	38.19	0.82
44.0	34.25	0.82	54.4	35.26	0.82
44.4	36.11	0.82	54.8	37.95	0.82
44.8	36.44	0.82	55.2	37.75	0.82
45.2	41.54	0.82	55.6	33.01	0.82
45.6	32.09	0.82	56.0	33.52	0.82
46.0	34.08	0.82	56.4	33.25	0.82
46.4	33.55	0.82	56.8	31.86	0.82
46.8	29.56	0.82	57.2	30.94	0.82
47.2	29.65	0.82	57.6	31.10	0.82
47.6	26.82	0.82	58.0	31.32	0.82
48.0	27.93	0.82	58.4	30.30	0.82
48.4	27.76	0.82	58.8	29.42	0.82
48.8	26.09	0.82	59.2	30.32	0.82
49.2	25.79	0.82	59.6	30.00	0.82
49.6	26.30	0.82	60.0	28.87	0.82
50.0	26.06	0.82	-	-	-

끝

F-02P-02-008 (Rev.02)

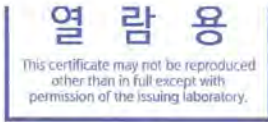

점검성적서

CHECK REPORTS

 경기도 이천시 마장면 서이천로 578번길 74
 Tel : 031-645-6900, Fax : 031-645-6969

 성적서발급번호(Certificate No) : IC-2019-63578
 점검번호(Checks No) : C-2019-074396

페이지(page) : 1 of 3

1. 의뢰자 (Client)

 - 기관명 (Name) : (주)에이치시티
 - 주소 (Address) : 경기도 이천시 마장면 서이천로 578번길 74

2. 측정기 (Check Subject)

◇ 등록번호 : 288237

 - 기기명 (Description) : WR-05 HARMONIC MIXER
 - 제작회사 및 형식 (Manufacturer and Model Name) : OML / M05HWD
 - 기기번호 (Serial Number) : 160419-1

3. 점검일자 (Date of Check)

: 2019.09.09

4. 점검환경 (Environment Conditions)

 - 온도(Temperature) : (23.2 ± 0.4) °C - 습도(Humidity) : (50 ± 2) % R.H.
 - 점검장소 (Location) : 고정표준실(Permanent Calibration Lab)

5. 측정표준의 소급성 (Traceability)
점검방법 및 소급성 서술 (Check method and/or brief description)

상기 기기는 고주파 스펙트럼 분석기의 교정절차(HCT-CS-125-40641)에 따라 국가측정표준기관으로부터 측정의 소급성이 확보된 아래의 아래의 표준장비와 자체 점검된 장비를 이용하여 점검 되었음.

점검에 사용한 표준장비 명세 (List of used standards/specifications)

기기명 (Description)	제작회사 및 형식 (Manufacturer and Model Name)	기기번호 (Serial Number)	차기교정예정일자 (The due date of next Calibration)	교정기관 (Calibration laboratory)
EXG ANALOG SIGNAL GENERATOR	KEYSIGHT N5173B	MY53270544	2019/10/04	(주)에이치시티
ERICKSON POWER METER	VDI PM5	394V	점검	(주)에이치시티
WR-05 MULTIPLIER SOURCE MODULE	OML S05MS-A	160419-1	점검	(주)에이치시티

6. 점검결과 (Check result)

: 점검결과 참조 (Refer to attachment)

확인 (affirmation)	작성자 (checks performed by)	승인자 (Approved by)
	성명 (Name) : 박민지	직위 (Title) : 기술책임자(Technical Cal. Manager) (장) 성명 (Name) : 이승찬

위 점검결과는 국가교정기관 제정제도 운영요령 제41조 규정에 의거하여 국가측정표준과 소급성이 확인된 측정기로서 점검한 성적서임을 증명합니다.

2019. 09. 11

 (주)에이치시티 대표이사
 President, HCT Co., Ltd.

㉠ 이 성적서는 측정기의 정밀정확도에 영향을 미치는 요소(과부하, 온도, 습도 등)의 급격한 변화가 발생한 경우에는 무효가 됩니다.

F-02P-02-010 (Rev.01)

점검결과

CHECK RESULT

성적서발급번호(Certificate No) : IC-2019-63578

페이지(page) : 2 of 3

점검번호(Checks No) : C-2019-074396

1. Conversion Loss Graph

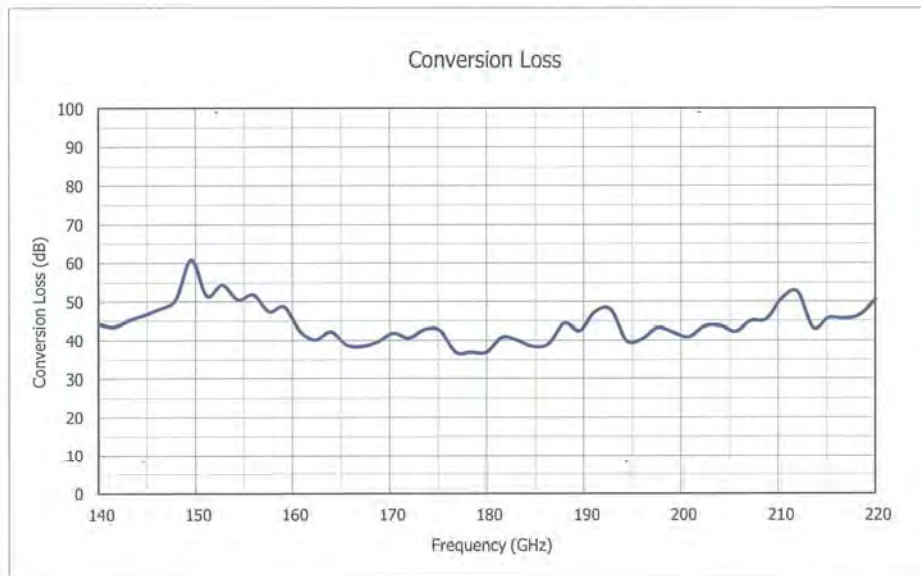

Note 1) R&S FSW (SN 104544)와 함께 교정된 결과임

Note 2) 측정 조건 : RF = -25 dBm, Harmonic Order = 16, L.O. Level = 17 dBm, Bias Value = 0.00 mA

Note 3) 110 GHz 초과 대역의 전력에 대해 국제적인 소급표준이 없으므로 HCT에서 자체적으로 소급된 기준기로 점검되었음.

- In the absence of power standards above 110 GHz, power measurements above 110 GHz are to confirm operation functionality and traceable only to HCT.

F-02P-02-010 (Rev.01)

점검결과

CHECK RESULT

성적서발급번호(Certificate No) : IC-2019-63578

페이지(page) : 3 of 3

점검번호(Checks No) : C-2019-074396

2. Conversion Loss Data

Frequency (GHz)	Conversion Loss (dB)	Measurement Uncertainty (dB)	Frequency (GHz)	Conversion Loss (dB)	Measurement Uncertainty (dB)
140.0	44.3	0.86	181.6	40.7	0.86
141.6	43.5	0.86	183.2	39.9	0.86
143.2	45.2	0.86	184.8	38.3	0.86
144.8	46.5	0.86	186.4	39.1	0.86
146.4	48.2	0.86	188.0	44.4	0.86
148.0	50.6	0.86	189.6	42.5	0.86
149.6	60.8	0.86	191.2	47.4	0.86
151.2	51.5	0.86	192.8	47.8	0.86
152.8	54.4	0.86	194.4	39.9	0.86
154.4	50.5	0.86	196.0	40.3	0.86
156.0	51.8	0.86	197.6	43.2	0.86
157.6	47.4	0.86	199.2	42.0	0.86
159.2	48.6	0.86	200.8	40.8	0.86
160.8	42.4	0.86	202.4	43.5	0.86
162.4	40.1	0.86	204.0	43.8	0.86
164.0	42.2	0.86	205.6	42.3	0.86
165.6	38.8	0.86	207.2	45.0	0.86
167.2	38.4	0.86	208.8	45.4	0.86
168.8	39.6	0.86	210.4	50.9	0.86
170.4	41.9	0.86	212.0	52.5	0.86
172.0	40.6	0.86	213.6	43.2	0.86
173.6	42.8	0.86	215.2	45.8	0.86
175.2	42.5	0.86	216.8	45.6	0.86
176.8	36.9	0.86	218.4	46.5	0.86
178.4	36.9	0.86	220.0	50.5	0.87
180.0	36.9	0.86	-	-	-

품

F-02P-02-010 (Rev.01)

7. Annex B_EUT AND TEST SETUP PHOTO

Please refer to test setup photo file no. as follows;

No.	Description
1	HCT-RF-2007-FC009-P