

# TEST REPORT

of

FCC Part 15 Subpart B&C §15.247/ RSS-210 Issue 8, RSS-Gen Issue 3

FCC ID/IC Certification: A3LHS6000/649E-HS6000

Equipment Under Test : Bluetooth Stereo Headset  
Model Name : HS6000  
Serial No. : N/A  
Applicant : SAMSUNG ELECTRONICS CO., LTD.  
Manufacturer : SAMSUNG ELECTRONICS CO., LTD.  
Date of Test(s) : 2011. 06. 08 ~ 2011. 06. 22  
Date of Issue : 2011. 06. 22

In the configuration tested, the EUT complied with the standards specified above.

Tested By:

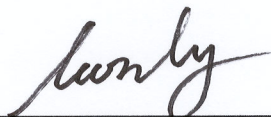

Grant Lee

Date

2011. 06. 22

Approved By



Charles Kim

Date

2011. 06. 22

*The results shown in this test report refer only to the sample(s) tested unless otherwise stated. This test report cannot be reproduced, except in full, without prior written permission of the Company.*

# INDEX

<u>Table of Contents</u>	Page
1. General Information -----	3
2. Transmitter Radiated Spurious Emissions and Conducted Spurious Emission -----	8
3. Receiver Radiated Spurious Emission-----	34
4. 20 dB Bandwidth and 99% BW -----	36
5. Maximum Peak Output Power -----	50
6. Hopping Channel Separation -----	52
7. Number of Hopping Frequency -----	56
8. Time of Occupancy(Dwell Time) -----	62
9. Transmitter AC Power Line Conducted Emission-----	75
10. Receiver AC Power Line Conducted Emission-----	80
11. Antenna Requirement -----	84
12. RF Exposure evaluation -----	85

*The results shown in this test report refer only to the sample(s) tested unless otherwise stated. This test report cannot be reproduced, except in full, without prior written permission of the Company.*

## 1. General Information

### 1.1. Testing Laboratory

SGS Korea Co., Ltd. (Gunpo Laboratory)  
 Wireless Div. 2FL, 18-34, Sanbon-dong, Gunpo-si, Gyeonggi-do, Korea 435-040  
[www.kr.sgs.com/ee](http://www.kr.sgs.com/ee)  
 Telephone : +82 +31 428 5700  
 FAX : +82 +31 427 2371

### 1.2. Details of Applicant

Applicant : SAMSUNG ELECTRONICS CO.,LTD.  
 Address : 416, Maetan-dong, Yeongtong-gu, Suwon-si, Gyeonggi-do, Korea  
 Contact Person : Kim, Jin-kyung  
 Phone No. : +82 31 301 4187

### 1.3. Description of EUT

<b>Kind of Product</b>	Bluetooth Stereo Headset
<b>Model Name</b>	HS6000
<b>Serial Number</b>	N / A
<b>Power Supply</b>	DC 3.7 V (Inner battery) DC 5.0 V (Micro USB)
<b>Frequency Range</b>	2 402 ~ 2 480 MHz
<b>Modulation Technique</b>	GFSK, $\pi/4$ DQPSK, 8DPSK
<b>Number of Channels</b>	79
<b>Antenna Type</b>	Integral Type (Chip Antenna)
<b>Antenna Gain</b>	0.242 dBi
<b>H/W Version</b>	REV1.0
<b>S/W Version</b>	HS6000_SW01

### 1.4. Declaration by the manufacturer

- N/A

*The results shown in this test report refer only to the sample(s) tested unless otherwise stated. This test report cannot be reproduced, except in full, without prior written permission of the Company.*

## 1.5. Information about the FHSS characteristics:

### 1.5.1. Pseudorandom Frequency Hopping Sequence

The channel is represented by a pseudo-random hopping sequence hopping through the 79 RF channels. The hopping sequence is unique for the piconet and is determined by the Bluetooth device address of the master; the phase in the hopping sequence is determined by the Bluetooth clock of the master. The channel is divided into time slots where each slot corresponds to an RF hop frequency. Consecutive hops correspond to different RF hop frequencies. The nominal hop rate is 1 600 hops/s.

### 1.5.2. Equal Hopping Frequency Use

All Bluetooth units participating in the piconet are time and hop-synchronized to the channel.

### 1.5.3. System Receiver Input Bandwidth

Each channel bandwidth is 1 MHz

---

*The results shown in this test report refer only to the sample(s) tested unless otherwise stated. This test report cannot be reproduced, except in full, without prior written permission of the Company.*

### 1.6. Test Equipment List

Equipment	Manufacturer	Model	S/N	Cal Due.
Signal Generator	Agilent	E4438C	MY42082477	Mar. 31, 2012
Signal Generator	R & S	SMR40	100272	Jul. 15, 2011
Spectrum Analyzer	R & S	FSP40	100007	Jul. 15, 2011
Bluetooth Tester	TESOM	TC-3000B	3000B630018	Sep. 17, 2011
Directional Coupler	KRYTAR	152613	122661	May. 16, 2012
High Pass Filter	Wainwright	WHK3.0/18G-10SS	344	Sep. 29, 2011
DC power Supply	Agilent	U8002A	MY49030063	Jan. 05, 2012
Preamplifier	H.P.	8447F	2944A03909	Jul. 05, 2011
Preamplifier	R & S	8449B	3008A01932	Mar. 31, 2012
Test Receiver	R & S	ESU26	100109	Feb. 21, 2012
Bilog Antenna	SCHWARZBECK MESSELEKTRONIK	VULB9163	396	Jul. 22, 2011
Horn Antenna	SCHWARZBECK MESSELEKTRONIK	BBHA9120D	BBHA9170431	Mar. 17, 2012
Horn Antenna	R & S	HF 906	100326	Oct. 08, 2011
Antenna Master	EMCO	1050	N.C.R.	N.C.R.
Turn Table	Daeil EMC	DI-1500	N.C.R.	N.C.R.
Anechoic Chamber	SY Corporation	L × W × H (9.6 m × 6.4 m × 6.6 m)	N.C.R.	N.C.R.
Two-Line V-Network	R & S	ENV216	100190	Jan. 06, 2012
Test Receiver	R & S	ESHS10	863365/018	Apr. 27, 2012
Anechoic Chamber	SY Corporation	L × W × H (6.5 m × 3.5 m × 3.5 m)	N.C.R.	N.C.R.

The results shown in this test report refer only to the sample(s) tested unless otherwise stated. This test report cannot be reproduced, except in full, without prior written permission of the Company.

## 1.7. Summary of Test Results

The EUT has been tested according to the following specifications:

APPLIED STANDARD:FCC Part15, RSS-210,RSS-Gen			
Section in FCC 15	Section in RSS-210 RSS-Gen	Test Item	Result
15.205(a) 15.209 15.247(d)	A8.5	Transmitter Radiated Spurious Emissions Conducted Spurious Emission	Complied
15.109(a)	RSS-Gen 6	Receiver Radiated Spurious Emission	Complied
15.247(a)(1)	A8.1(1)	20 dB Bandwidth and 99% BW	Complied
15.247(b)(1)	A8.4(2)	Maximum Peak Output Power	Complied
15.247(a)(1)	A8.1(2)	Frequency Separation	Complied
15.247(b)(1)	A8.1(4)	Number of Hopping Frequency	Complied
15.247(a)(1)(iii)	A8.1(4)	Time of Occupancy (Dwell Time)	Complied
15.207	RSS-Gen 7.2.4	Transmitter AC Power Line Conducted Emission	Complied
15.107	RSS-Gen 7.2.4	Receiver AC Power Line Conducted Emission	Complied
15.247(i) 1.1307(b)(1)	RSS-Gen 5.5/ RSS-102	Maximum Permissible Exposure (Exposure of Humans to RF Fields)	Complied

*The results shown in this test report refer only to the sample(s) tested unless otherwise stated. This test report cannot be reproduced, except in full, without prior written permission of the Company.*

## 1.8 Conclusion of worst-case and operation mode

The EUT has three type of modulation (GFSK,  $\pi/4$ DQPSK and 8DPSK). Each output power as following:

Modulation Type	Output power(dB m)	Output power(mW)	Symbol rate
GFSK(2 441 MHz)	0.78	1.20	1 Mbps
$\pi/4$ DQPSK(2 441 MHz)	2.15	1.64	2 Mbps
8DPSK(2 441 MHz)	2.63	1.83	3 Mbps

Therefore all applicable requirements were tested to the two type of higher output power modulation (GFSK and 8DPSK) at middle channel (2 441 MHz).

The field strength of spurious emission was measured in three orthogonal EUT positions (x-axis, y-axis and z-axis). Worst case is y -axis.

## 1.9. Test report revision

Revision	Report number	Description
0	F690501/RF-RTL004767	Initial

*The results shown in this test report refer only to the sample(s) tested unless otherwise stated. This test report cannot be reproduced, except in full, without prior written permission of the Company.*

## 2. Transmitter Radiated Spurious Emissions and Conducted Spurious Emission

### 2.1. Test Setup

#### 2.1.1. Transmitter Radiated Spurious Emissions

The diagram below shows the test setup that is utilized to make the measurements for emission from 30 MHz to 1 GHz Emissions.

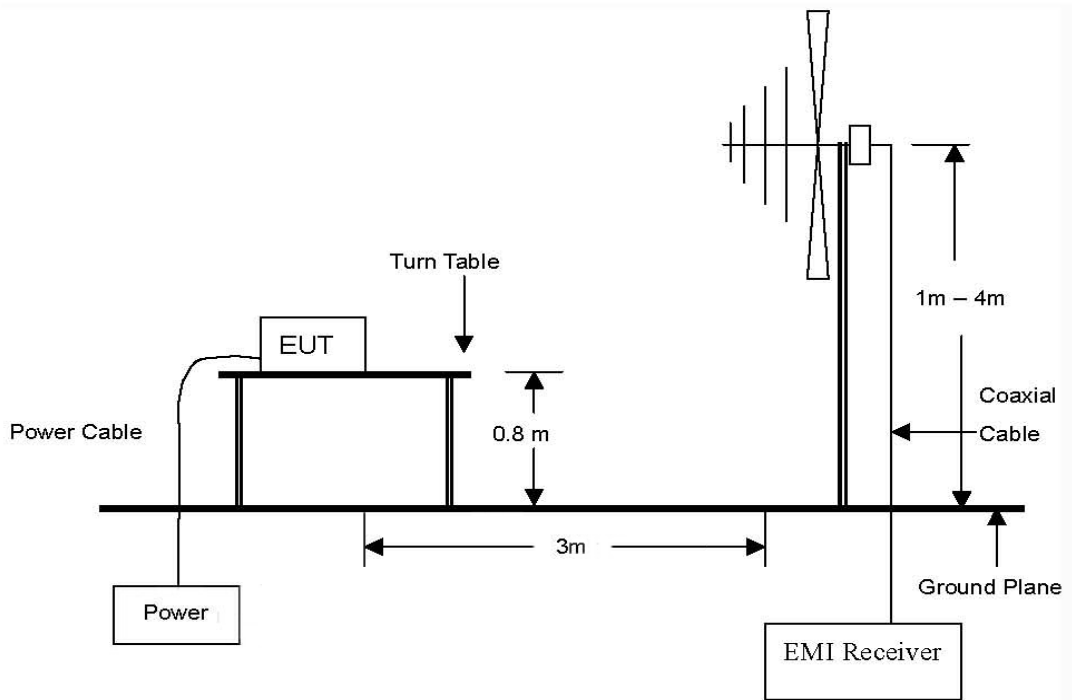

The diagram below shows the test setup that is utilized to make the measurements for emission from 1 GHz to 24 GHz Emissions.

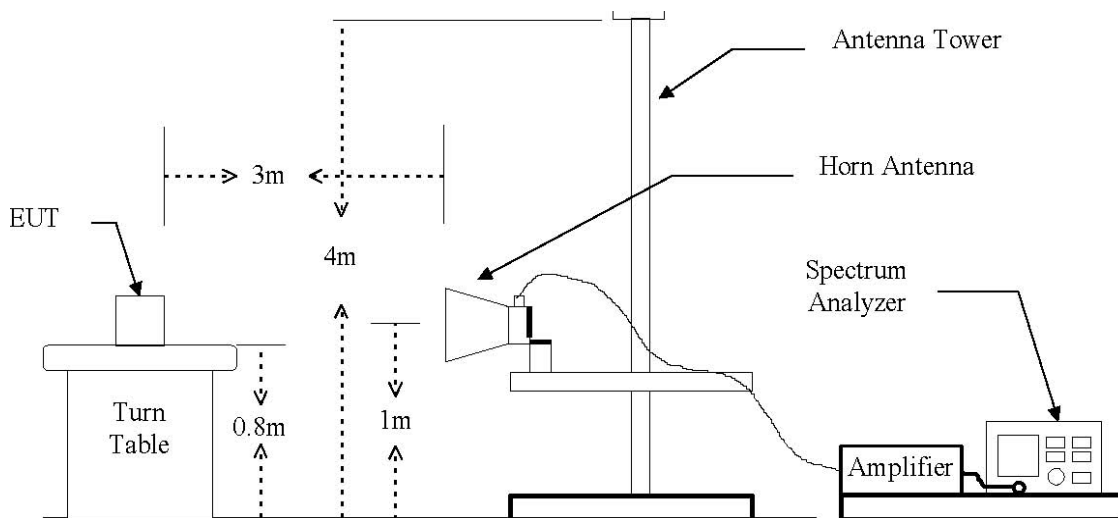

*The results shown in this test report refer only to the sample(s) tested unless otherwise stated. This test report cannot be reproduced, except in full, without prior written permission of the Company.*

### 2.1.2. Conducted Spurious Emissions

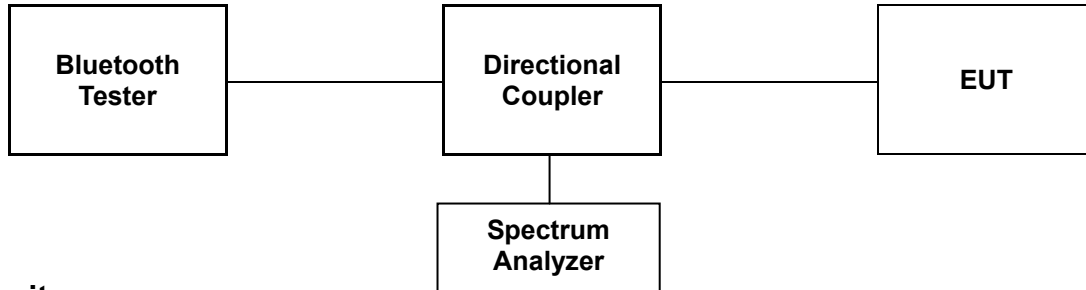

### 2.2. Limit

According to §15.247(d), in any 100 kHz bandwidth outside the frequency band in which the spread spectrum or digitally modulated intentional radiator is operating, the radio frequency power that is produced by the intentional radiator shall be at least 20 dB below that in the 100 kHz bandwidth within the band that contains the highest level of the desired power, based on either an RF conducted or a radiated measurement, provided the transmitter demonstrates compliance with the peak conducted power limits. If the transmitter complies with the conducted power limits based on the use of RMS averaging over a time interval, as permitted under paragraph(b)(3) of this section, the attenuation required under this paragraph shall be 30 dB instead of 20 dB. Attenuation below the general limits specified in section §15.209(a) is not required. In addition, radiated emission which in the restricted band, as define in section §15.205(a), must also comply the radiated emission limits specified in section §15.209(a) (see section §15.205(c))

According to § 15.209(a), Except as provided elsewhere in this Subpart, the emissions from an intentional radiator shall not exceed the field strength levels specified in the following table :

Frequency (MHz)	Distance (Meters)	Field Strength (dB µV/m)	Field Strength (µV/m)
30 - 88	3	40.0	100
88 – 216	3	43.5	150
216 – 960	3	46.0	200
Above 960	3	54.0	500

*The results shown in this test report refer only to the sample(s) tested unless otherwise stated. This test report cannot be reproduced, except in full, without prior written permission of the Company.*

## 2.3. Test Procedures

Radiated emissions from the EUT were measured according to the dictates of ANSI C63.4:2003

### 2.3.1. Test Procedures for Radiated Spurious Emissions

1. The EUT was placed on the top of a rotating table 0.8 meters above the ground at a 3 meter anechoic chamber test site. The table was rotated 360 degrees to determine the position of the highest radiation.
2. During performing radiated emission below 1 GHz, the EUT was set 3 meters away from the interference receiving antenna, which was mounted on the top of a variable-height antenna tower. During performing radiated emission above 1 GHz, the EUT was set 3 meter away from the interference-receiving antenna.
3. The antenna is a broadband antenna, and its height is varied from one meter to four meters above the ground to determine the maximum value of the field strength. Both horizontal and vertical polarizations of the antenna are set to make the measurement.
4. For each suspected emission, the EUT was arranged to its worst case and then the antenna was tuned to heights from 1 meter to 4 meters and the table was turned from 0 degrees to 360 degrees to find the maximum reading.
5. The test-receiver system was set to Peak Detect Function and Specified Bandwidth with Maximum Hold Mode.
6. If the emission level of the EUT in peak mode was 10 dB lower than the limit specified, then testing could be stopped and the peak values of the EUT would be reported. Otherwise the emissions that did not have 10 dB margin would be re-tested one by one using peak, quasi-peak or average method as specified and then reported in a data sheet.

NOTE ;

1. The resolution bandwidth and video bandwidth of test receiver/spectrum analyzer is 120 kHz for Peak detection (PK) and Quasi-peak detection (QP) at frequency below 1 GHz.
2. The resolution bandwidth and video bandwidth of test receiver/spectrum analyzer is 1 MHz for Peak detection and frequency above 1 GHz.
3. The resolution bandwidth of test receiver/spectrum analyzer is 1 MHz and the video bandwidth is 10 Hz for Average detection (AV) at frequency above 1 GHz.

### 2.3.2. Test Procedures for Conducted Spurious Emissions

1. The transmitter output was connected to the spectrum analyzer.
2. The bandwidth of the fundamental frequency was measured with the spectrum analyzer using RBW=100 kHz, VBW=100 kHz.

---

*The results shown in this test report refer only to the sample(s) tested unless otherwise stated. This test report cannot be reproduced, except in full, without prior written permission of the Company.*

## 2.4. Test Results

Ambient temperature : (23 ± 2) °C  
 Relative humidity : 47 % R.H.

### 2.4.1. Spurious Radiated Emission (Worst case configuration\_8DPSK )

The frequency spectrum from 30 MHz to 1 000 MHz was investigated. Emission levels are not reported much lower than the limits by over 30 dB. All reading values are peak values.

Radiated Emissions			Ant	Correction Factors		Total	FCC Limit	
Frequency (MHz)	Reading (dB $\mu$ V)	Detect Mode	Pol.	AF (dB/m)	AMP + CL (dB)	Actual (dB $\mu$ V/m)	Limit (dB $\mu$ V/m)	Margin (dB)
170.690	49.00	Peak	H	8.54	-26.05	31.49	40.00	8.51
403.127	43.01	Peak	H	16.15	-25.55	33.61	46.00	12.39
425.477	42.60	Peak	H	16.57	-25.60	33.57	46.00	12.43
433.477	42.50	Peak	H	16.73	-25.62	33.61	46.00	12.39
442.088	42.60	Peak	H	16.89	-25.63	33.86	46.00	12.14
Above 500.000	Not Detected	-	-	-	-	-	-	-

#### Remark:

1. All spurious emission at channels are almost the same below 1 GHz, so that middle channel was chosen at representative in final test.
2. Actual = Reading + AF + AMP + CL
3. The field strength of spurious emission was measured in three orthogonal EUT positions(x-axis, y-axis and z-axis). Worst case is y-axis.

*The results shown in this test report refer only to the sample(s) tested unless otherwise stated. This test report cannot be reproduced, except in full, without prior written permission of the Company.*

## 2.4.2. Spurious Radiated Emission

The frequency spectrum above 1 000 MHz was investigated. Emission levels are not reported much lower than the limits by over 30 dB.

### Operating Mode: GFSK (Inner battery)

#### A. Low Channel (2 402 MHz)

Radiated Emissions			Ant	Correction Factors		Total	FCC Limit	
Frequency (MHz)	Reading (dB $\mu$ V)	Detect Mode	Pol.	AF (dB/m)	CL (dB)	Actual (dB $\mu$ V/m)	Limit (dB $\mu$ V/m)	Margin (dB)
2 390.00	25.46	Peak	H	28.09	6.23	59.78	74.00	14.22
2 390.00	10.58	Average	H	28.09	6.23	44.90	54.00	9.10

Radiated Emissions			Ant	Correction Factors		Total	FCC Limit	
Frequency (MHz)	Reading (dB $\mu$ V)	Detect Mode	Pol.	AF (dB/m)	AMP+CL (dB)	Actual (dB $\mu$ V/m)	Limit (dB $\mu$ V/m)	Margin (dB)
4 804.03	49.98	Peak	H	32.59	25.04	57.54	74.00	16.46
4 804.03	34.66	Average	H	32.59	25.04	42.22	54.00	11.78
Above 4 900.00	Not Detected	-	-	-	-	-	-	-

#### B. Middle Channel (2 441 MHz)

Radiated Emissions			Ant	Correction Factors		Total	FCC Limit	
Frequency (MHz)	Reading (dB $\mu$ V)	Detect Mode	Pol.	AF (dB/m)	AMP+CL (dB)	Actual (dB $\mu$ V/m)	Limit (dB $\mu$ V/m)	Margin (dB)
4 882.01	48.91	Peak	H	32.90	25.26	56.55	74.00	17.45
4 882.01	40.07	Average	H	32.90	25.26	47.71	54.00	6.29
Above 4 900.00	Not Detected	-	-	-	-	-	-	-

The results shown in this test report refer only to the sample(s) tested unless otherwise stated. This test report cannot be reproduced, except in full, without prior written permission of the Company.

## C. High Channel (2 480 MHz)

Radiated Emissions			Ant	Correction Factors		Total	FCC Limit	
Frequency (MHz)	Reading (dB $\mu$ V)	Detect Mode	Pol.	AF (dB/m)	CL (dB)	Actual (dB $\mu$ V/m)	Limit (dB $\mu$ V/m)	Margin (dB)
2 483.50	26.04	Peak	H	28.09	6.36	60.48	74.00	13.52
2 483.50	13.13	Average	H	28.09	6.36	47.57	54.00	6.43

Radiated Emissions			Ant	Correction Factors		Total	FCC Limit	
Frequency (MHz)	Reading (dB $\mu$ V)	Detect Mode	Pol.	AF (dB/m)	AMP+CL (dB)	Actual (dB $\mu$ V/m)	Limit (dB $\mu$ V/m)	Margin (dB)
4 960.14	48.50	Peak	H	33.22	24.64	57.08	74.00	16.92
4 960.14	34.41	Average	H	33.22	24.64	42.99	54.00	11.01
Above 5 000.00	Not Detected	-	-	-	-	-	-	-

**Operating Mode: 8DPSK (Inner battery)**

## A. Low Channel (2 402 MHz)

Radiated Emissions			Ant	Correction Factors		Total	FCC Limit	
Frequency (MHz)	Reading (dB $\mu$ V)	Detect Mode	Pol.	AF (dB/m)	CL (dB)	Actual (dB $\mu$ V/m)	Limit (dB $\mu$ V/m)	Margin (dB)
2 390.00	24.40	Peak	H	28.09	6.23	58.72	74.00	15.28
2 390.00	10.60	Average	H	28.09	6.23	44.92	54.00	9.08

Radiated Emissions			Ant	Correction Factors		Total	FCC Limit	
Frequency (MHz)	Reading (dB $\mu$ V)	Detect Mode	Pol.	AF (dB/m)	AMP+CL (dB)	Actual (dB $\mu$ V/m)	Limit (dB $\mu$ V/m)	Margin (dB)
4 804.67	48.55	Peak	H	32.60	25.04	56.11	74.00	17.89
4 804.67	31.87	Average	H	32.60	25.04	39.43	54.00	14.57
Above 4 900.00	Not Detected	-	-	-	-	-	-	-

The results shown in this test report refer only to the sample(s) tested unless otherwise stated. This test report cannot be reproduced, except in full, without prior written permission of the Company.

## B. Middle Channel (2 441 MHz)

Radiated Emissions			Ant	Correction Factors		Total	FCC Limit	
Frequency (MHz)	Reading (dB $\mu$ V)	Detect Mode	Pol.	AF (dB/m)	AMP+CL (dB)	Actual (dB $\mu$ V/m)	Limit (dB $\mu$ V/m)	Margin (dB)
4 882.67	47.09	Peak	H	32.91	25.26	54.74	74.00	19.26
4 882.67	31.64	Average	H	32.91	25.26	39.29	54.00	14.71
Above 4 900.00	Not Detected	-	-	-	-	-	-	-

## C. High Channel (2 480 MHz)

Radiated Emissions			Ant	Correction Factors		Total	FCC Limit	
Frequency (MHz)	Reading (dB $\mu$ V)	Detect Mode	Pol.	AF (dB/m)	CL (dB)	Actual (dB $\mu$ V/m)	Limit (dB $\mu$ V/m)	Margin (dB)
2 483.50	35.05	Peak	H	28.09	6.36	69.49	74.00	4.51
2 483.50	13.22	Average	H	28.09	6.36	47.66	54.00	6.34

Radiated Emissions			Ant	Correction Factors		Total	FCC Limit	
Frequency (MHz)	Reading (dB $\mu$ V)	Detect Mode	Pol.	AF (dB/m)	AMP+CL (dB)	Actual (dB $\mu$ V/m)	Limit (dB $\mu$ V/m)	Margin (dB)
4 959.93	46.76	Peak	H	33.22	24.64	55.35	74.00	18.65
4 959.93	36.59	Average	H	33.22	24.64	45.18	54.00	8.82
Above 5 000.00	Not Detected	-	-	-	-	-	-	-

The results shown in this test report refer only to the sample(s) tested unless otherwise stated. This test report cannot be reproduced, except in full, without prior written permission of the Company.

**Operating Mode: GFSK (Micro USB)**

## A. Low Channel (2 402 MHz)

Radiated Emissions			Ant	Correction Factors		Total	FCC Limit	
Frequency (MHz)	Reading (dB $\mu$ V)	Detect Mode	Pol.	AF (dB/m)	CL (dB)	Actual (dB $\mu$ V/m)	Limit (dB $\mu$ V/m)	Margin (dB)
2 390.00	26.45	Peak	H	28.09	6.23	60.77	74.00	13.23
2 390.00	13.54	Average	H	28.09	6.23	47.86	54.00	6.14

Radiated Emissions			Ant	Correction Factors		Total	FCC Limit	
Frequency (MHz)	Reading (dB $\mu$ V)	Detect Mode	Pol.	AF (dB/m)	AMP+CL (dB)	Actual (dB $\mu$ V/m)	Limit (dB $\mu$ V/m)	Margin (dB)
4 804.01	49.85	Peak	H	32.59	25.04	57.41	74.00	16.59
4 804.01	34.51	Average	H	32.59	25.04	42.07	54.00	11.93
Above 4 900.00	Not Detected	-	-	-	-	-	-	-

## B. Middle Channel (2 441 MHz)

Radiated Emissions			Ant	Correction Factors		Total	FCC Limit	
Frequency (MHz)	Reading (dB $\mu$ V)	Detect Mode	Pol.	AF (dB/m)	AMP+CL (dB)	Actual (dB $\mu$ V/m)	Limit (dB $\mu$ V/m)	Margin (dB)
4 882.04	48.84	Peak	H	32.90	25.26	56.48	74.00	17.52
4 882.04	40.11	Average	H	32.90	25.26	47.75	54.00	6.25
Above 4 900.00	Not Detected	-	-	-	-	-	-	-

The results shown in this test report refer only to the sample(s) tested unless otherwise stated. This test report cannot be reproduced, except in full, without prior written permission of the Company.

## C. High Channel (2 480 MHz)

Radiated Emissions			Ant	Correction Factors		Total	FCC Limit	
Frequency (MHz)	Reading (dB $\mu$ V)	Detect Mode	Pol.	AF (dB/m)	CL (dB)	Actual (dB $\mu$ V/m)	Limit (dB $\mu$ V/m)	Margin (dB)
2 483.50	26.32	Peak	H	28.09	6.36	60.76	74.00	13.24
2 483.50	15.09	Average	H	28.09	6.36	49.53	54.00	4.47

Radiated Emissions			Ant	Correction Factors		Total	FCC Limit	
Frequency (MHz)	Reading (dB $\mu$ V)	Detect Mode	Pol.	AF (dB/m)	AMP+CL (dB)	Actual (dB $\mu$ V/m)	Limit (dB $\mu$ V/m)	Margin (dB)
4 960.16	48.45	Peak	H	33.22	24.64	57.03	74.00	16.97
4 960.16	34.33	Average	H	33.22	24.64	42.91	54.00	11.09
Above 5 000.00	Not Detected	-	-	-	-	-	-	-

**Operating Mode: 8DPSK (Micro USB)**

## A. Low Channel (2 402 MHz)

Radiated Emissions			Ant	Correction Factors		Total	FCC Limit	
Frequency (MHz)	Reading (dB $\mu$ V)	Detect Mode	Pol.	AF (dB/m)	CL (dB)	Actual (dB $\mu$ V/m)	Limit (dB $\mu$ V/m)	Margin (dB)
2 390.00	24.68	Peak	H	28.09	6.23	59.00	74.00	15.00
2 390.00	15.62	Average	H	28.09	6.23	49.94	54.00	4.06

Radiated Emissions			Ant	Correction Factors		Total	FCC Limit	
Frequency (MHz)	Reading (dB $\mu$ V)	Detect Mode	Pol.	AF (dB/m)	AMP+CL (dB)	Actual (dB $\mu$ V/m)	Limit (dB $\mu$ V/m)	Margin (dB)
4 804.07	48.66	Peak	H	32.59	25.04	56.22	74.00	17.78
4 804.07	31.92	Average	H	32.59	25.04	39.48	54.00	14.52
Above 4 900.00	Not Detected	-	-	-	-	-	-	-

The results shown in this test report refer only to the sample(s) tested unless otherwise stated. This test report cannot be reproduced, except in full, without prior written permission of the Company.

## B. Middle Channel (2 441 MHz)

Radiated Emissions			Ant	Correction Factors		Total	FCC Limit	
Frequency (MHz)	Reading (dB $\mu$ V)	Detect Mode	Pol.	AF (dB/m)	AMP+CL (dB)	Actual (dB $\mu$ V/m)	Limit (dB $\mu$ V/m)	Margin (dB)
4 882.12	48.22	Peak	H	32.90	25.26	55.86	74.00	18.14
4 882.12	31.66	Average	H	32.90	25.26	39.30	54.00	14.70
Above 4 900.00	Not Detected	-	-	-	-	-	-	-

## C. High Channel (2 480 MHz)

Radiated Emissions			Ant	Correction Factors		Total	FCC Limit	
Frequency (MHz)	Reading (dB $\mu$ V)	Detect Mode	Pol.	AF (dB/m)	CL (dB)	Actual (dB $\mu$ V/m)	Limit (dB $\mu$ V/m)	Margin (dB)
2 483.50	35.12	Peak	H	28.09	6.36	69.56	74.00	4.44
2 483.50	15.21	Average	H	28.09	6.36	49.65	54.00	4.35

Radiated Emissions			Ant	Correction Factors		Total	FCC Limit	
Frequency (MHz)	Reading (dB $\mu$ V)	Detect Mode	Pol.	AF (dB/m)	AMP+CL (dB)	Actual (dB $\mu$ V/m)	Limit (dB $\mu$ V/m)	Margin (dB)
4 959.99	48.12	Peak	H	33.22	24.64	56.71	74.00	17.29
4 959.99	35.40	Average	H	33.22	24.64	43.99	54.00	10.01
Above 5 000.00	Not Detected	-	-	-	-	-	-	-

**Remarks :**

1. "\*" means the restricted band.
2. Measuring frequencies from 1 GHz to the 10<sup>th</sup> harmonic of highest fundamental Frequency.
3. Radiated emissions measured in frequency above 1 000 MHz were made with an instrument using peak/average detector mode.
4. Average test would be performed if the peak result were greater than the average limit.
5. Actual = Reading + AF + AMP + CL
6. The field strength of spurious emission was measured in three orthogonal EUT positions(x-axis, y-axis and z-axis). Worst case is y-axis.

The results shown in this test report refer only to the sample(s) tested unless otherwise stated. This test report cannot be reproduced, except in full, without prior written permission of the Company.

### 2.4.3. Spurious RF Conducted Emissions: Plot of Spurious RF Conducted Emission Operating Mode: GFSK (Inner battery)

Low Channel

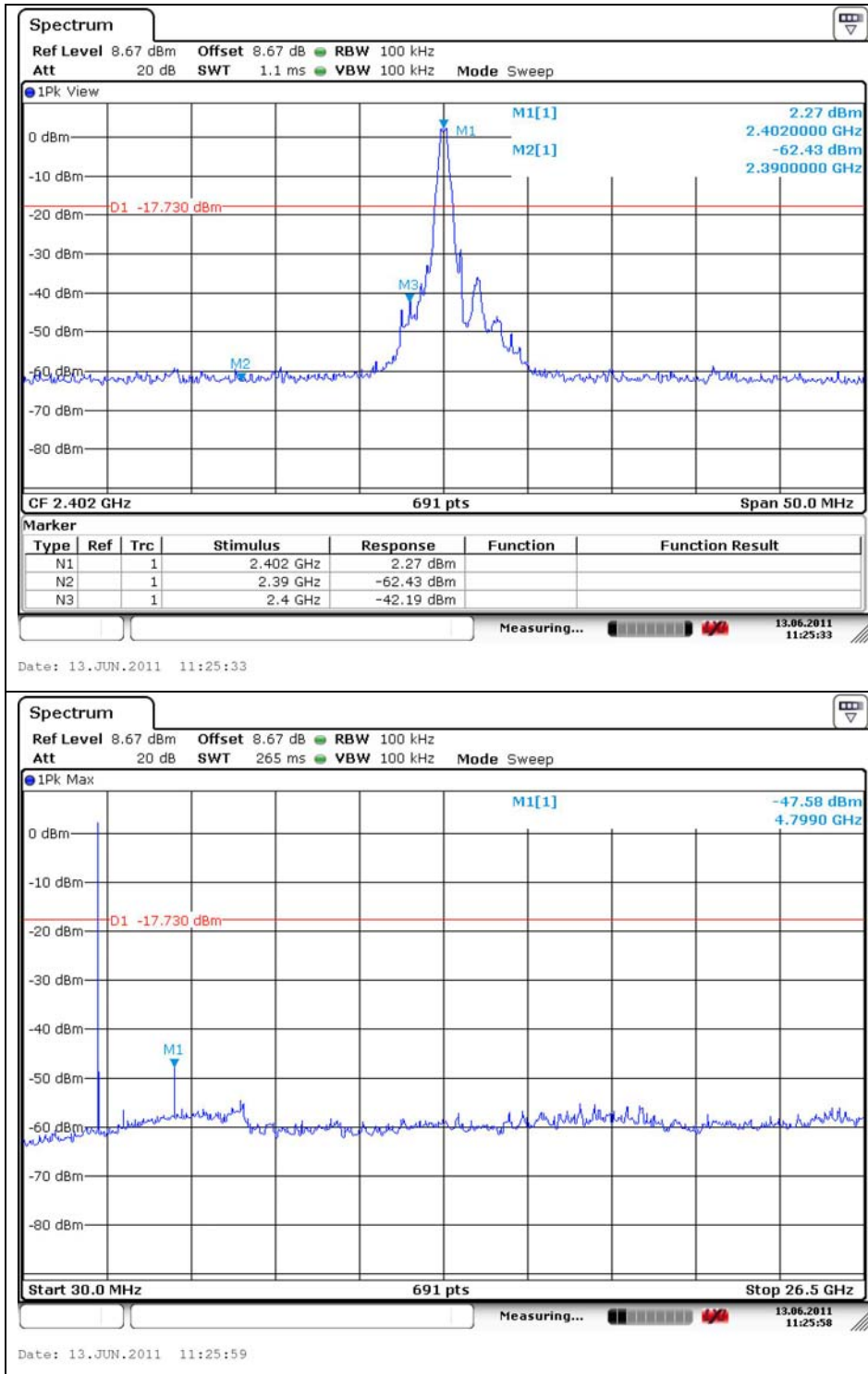

The results shown in this test report refer only to the sample(s) tested unless otherwise stated. This test report cannot be reproduced, except in full, without prior written permission of the Company.

Middle Channel

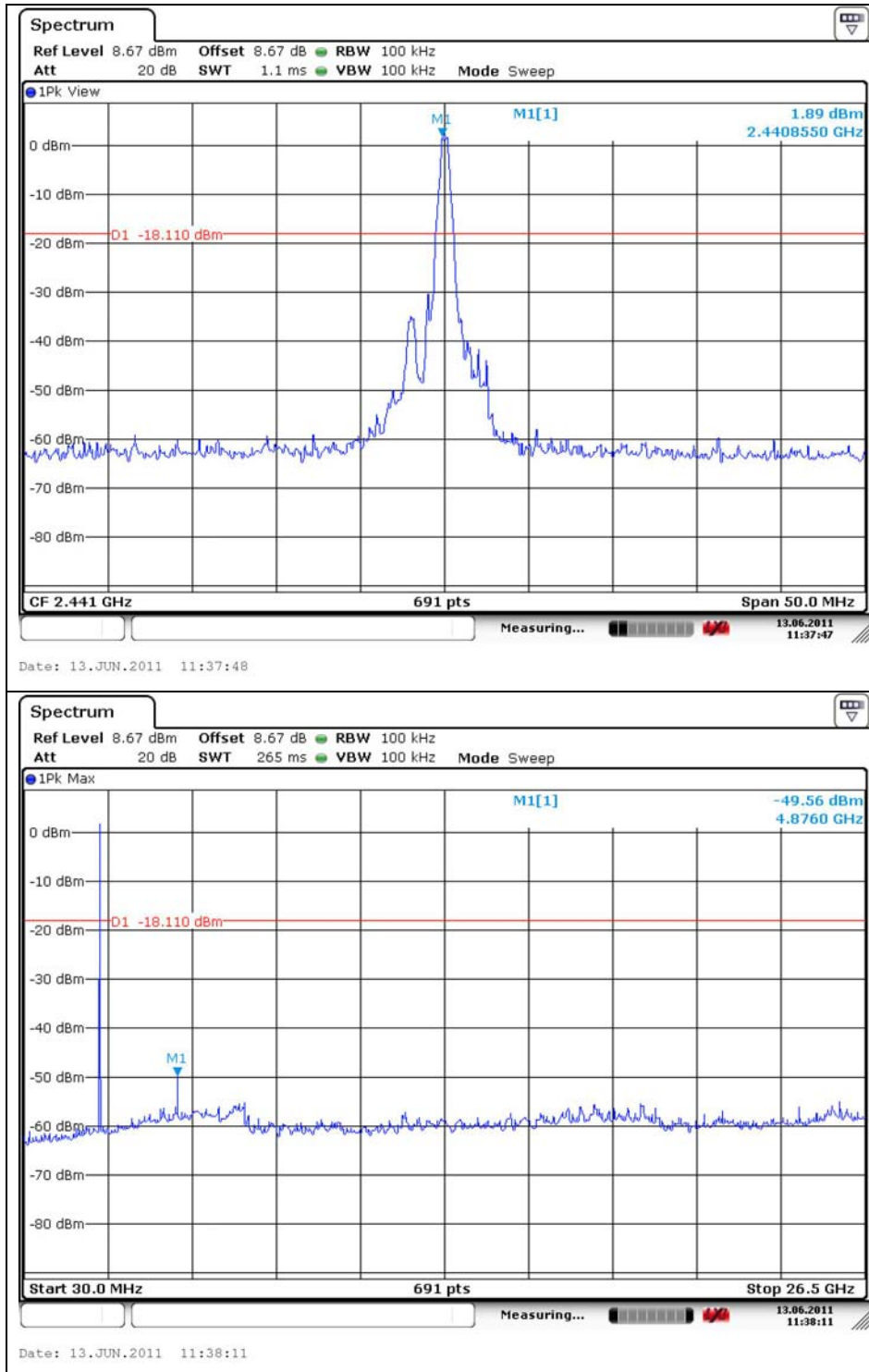

The results shown in this test report refer only to the sample(s) tested unless otherwise stated. This test report cannot be reproduced, except in full, without prior written permission of the Company.

High Channel

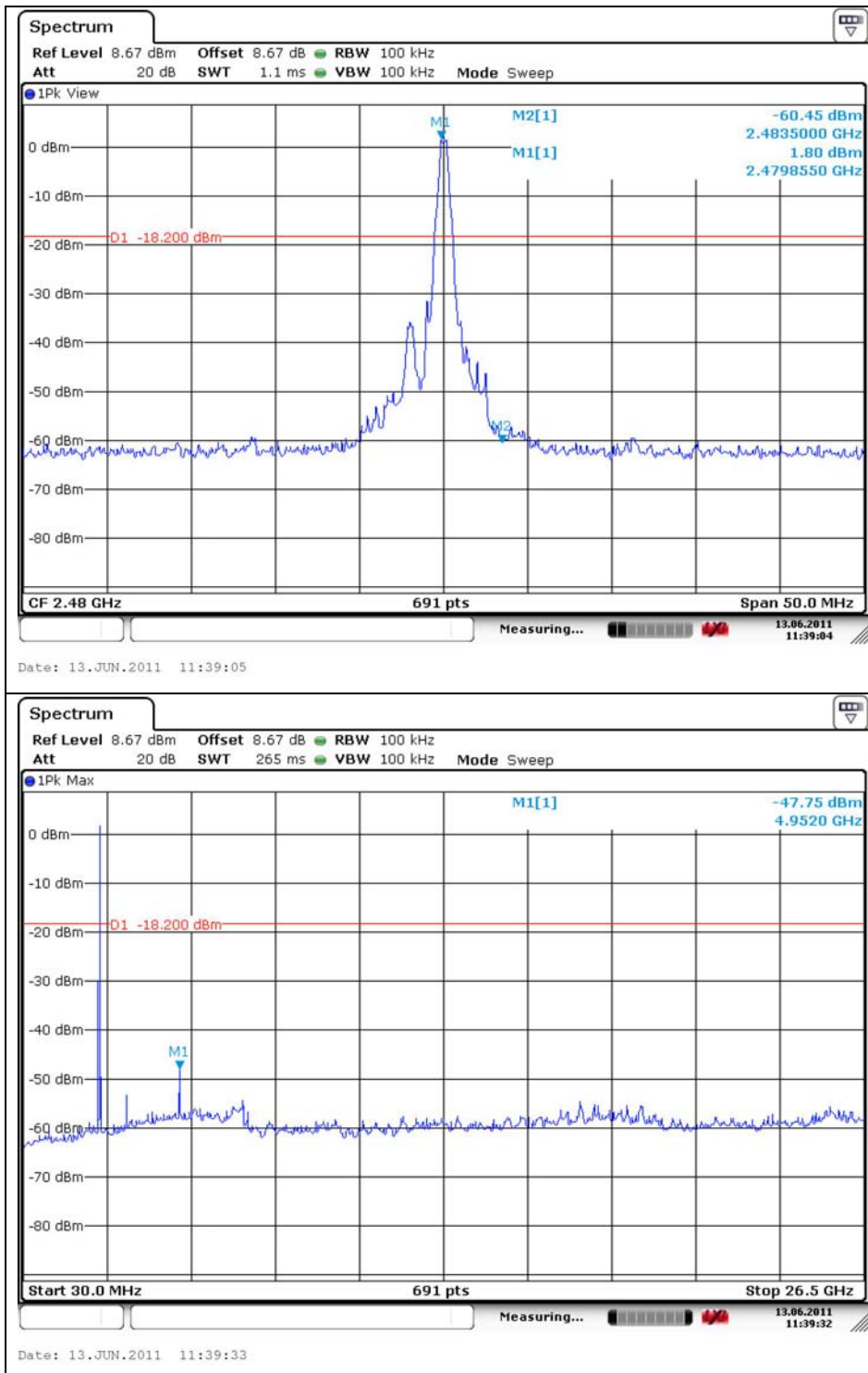

The results shown in this test report refer only to the sample(s) tested unless otherwise stated. This test report cannot be reproduced, except in full, without prior written permission of the Company.

Bandedge at Hopping

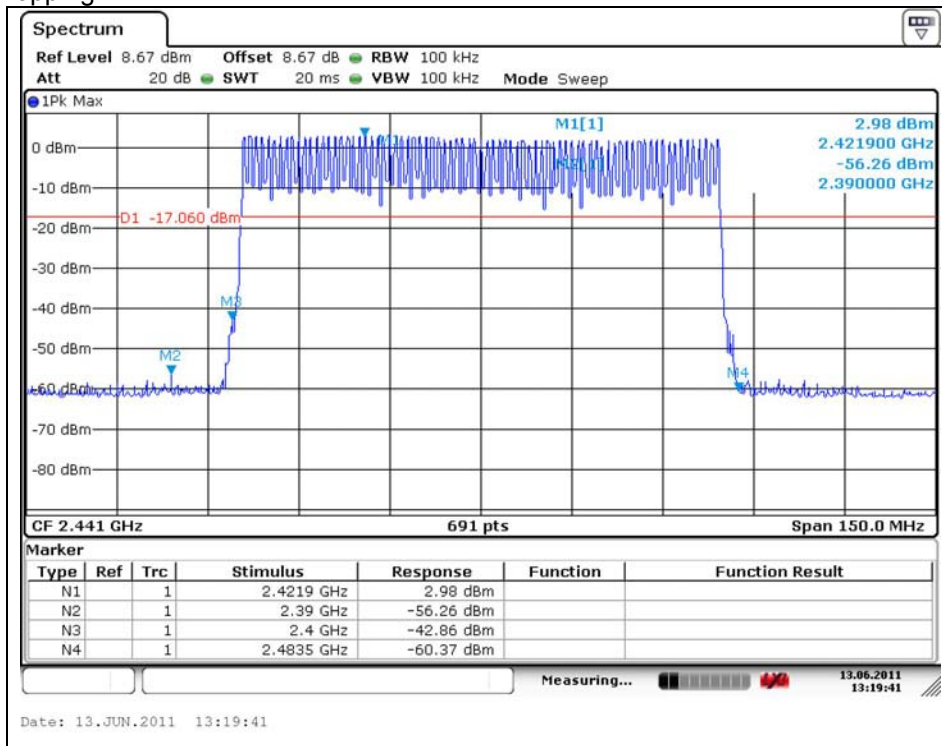

The results shown in this test report refer only to the sample(s) tested unless otherwise stated. This test report cannot be reproduced, except in full, without prior written permission of the Company.

## Operating Mode: 8DPSK (Inner battery)

### Low Channel

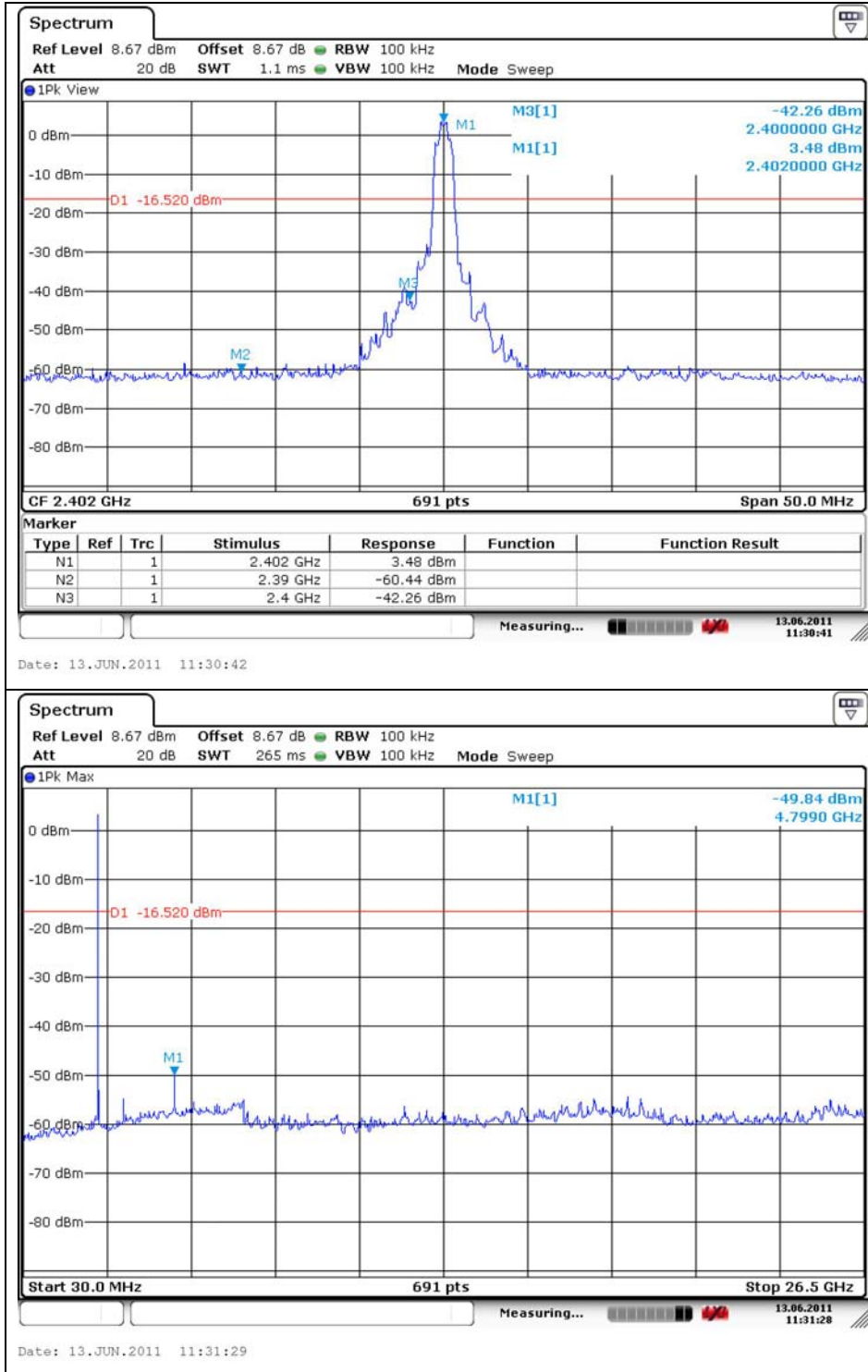

The results shown in this test report refer only to the sample(s) tested unless otherwise stated. This test report cannot be reproduced, except in full, without prior written permission of the Company.

Middle Channel

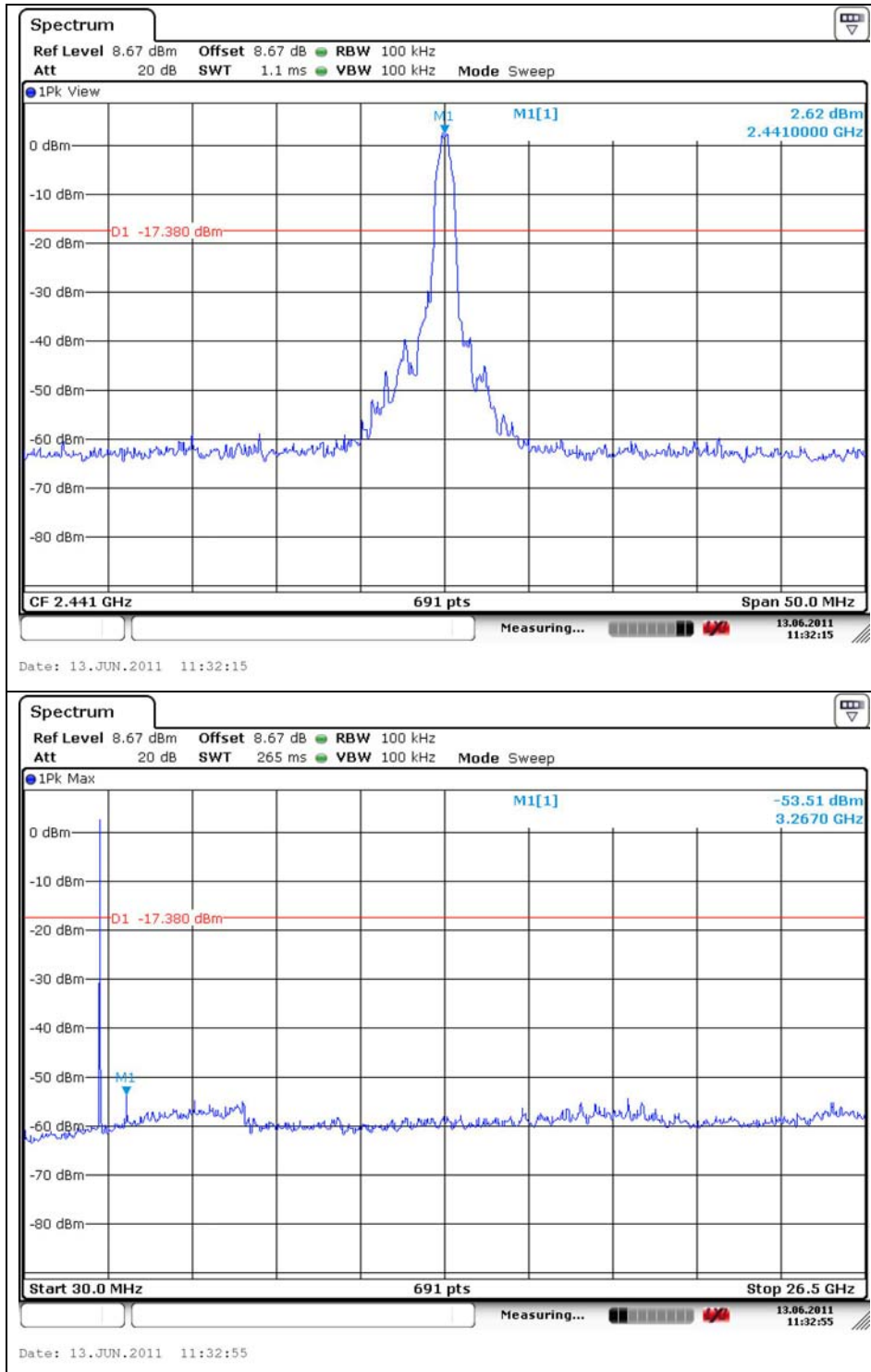

The results shown in this test report refer only to the sample(s) tested unless otherwise stated. This test report cannot be reproduced, except in full, without prior written permission of the Company.

High Channel

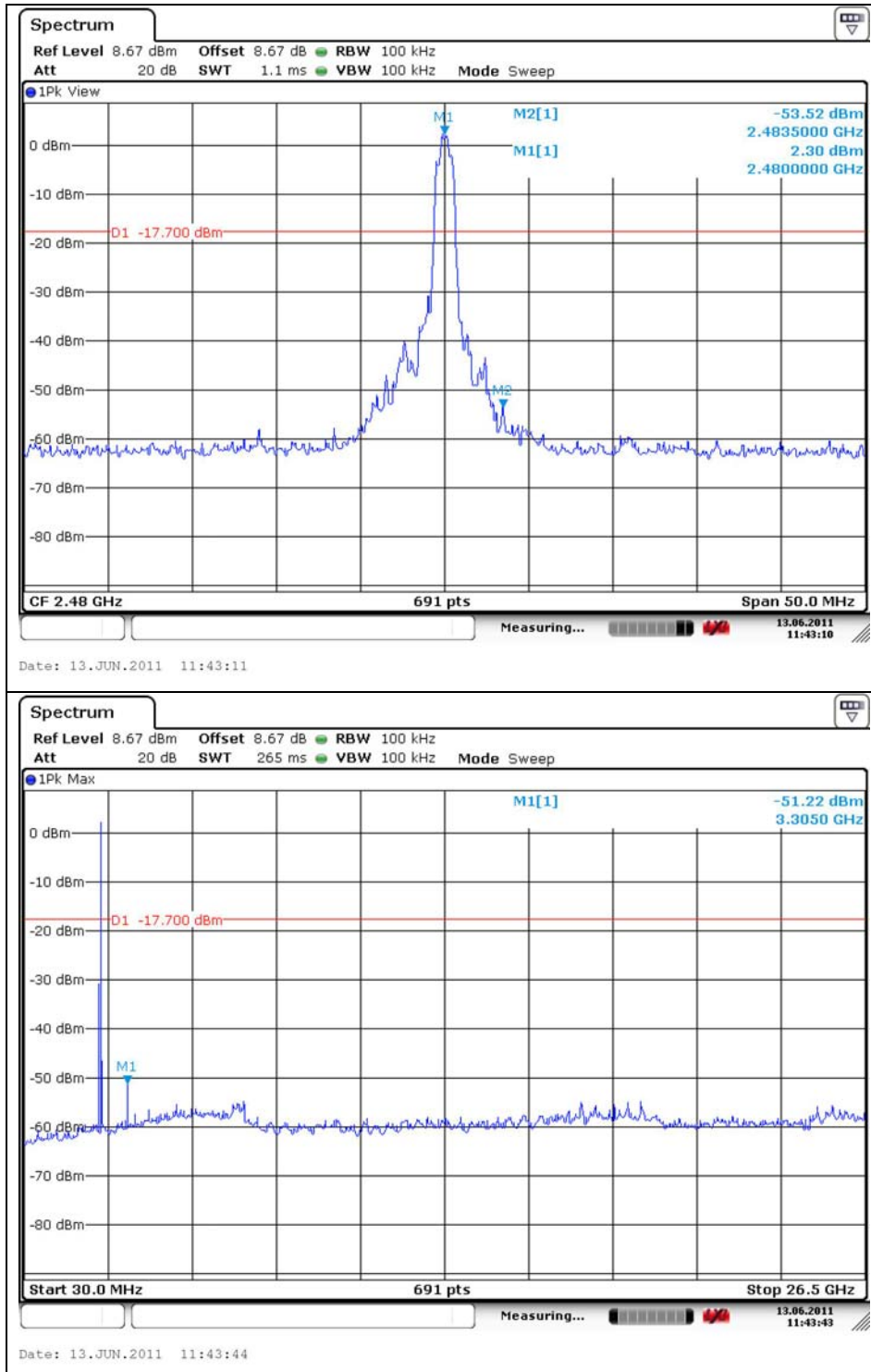

The results shown in this test report refer only to the sample(s) tested unless otherwise stated. This test report cannot be reproduced, except in full, without prior written permission of the Company.

Bandedge at Hopping

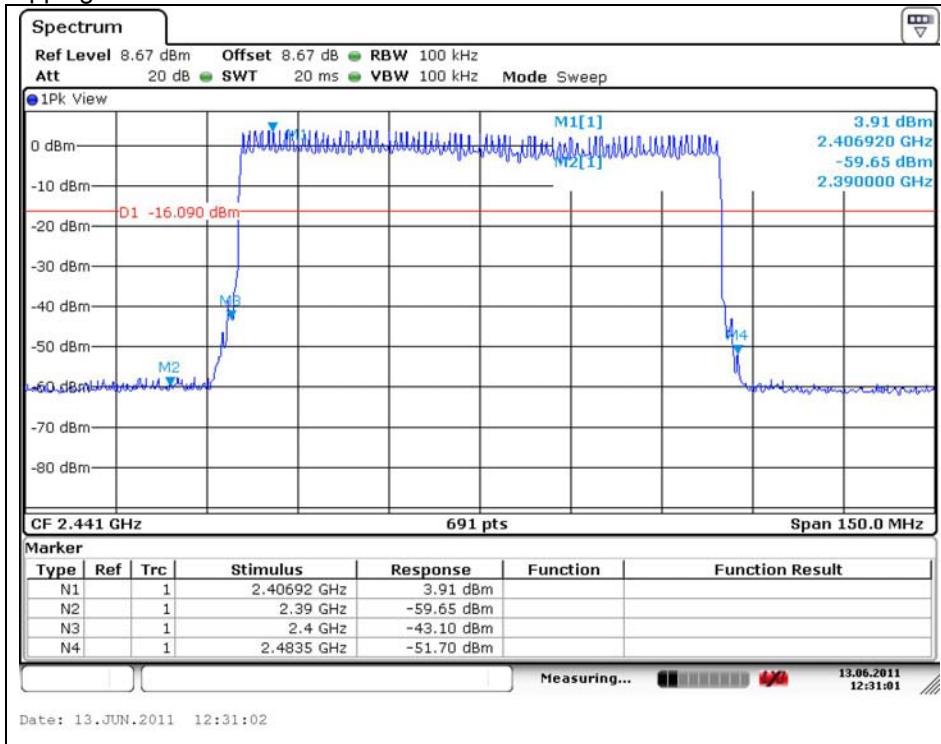

The results shown in this test report refer only to the sample(s) tested unless otherwise stated. This test report cannot be reproduced, except in full, without prior written permission of the Company.

## Operating Mode: GFSK (Micro USB)

Low Channel

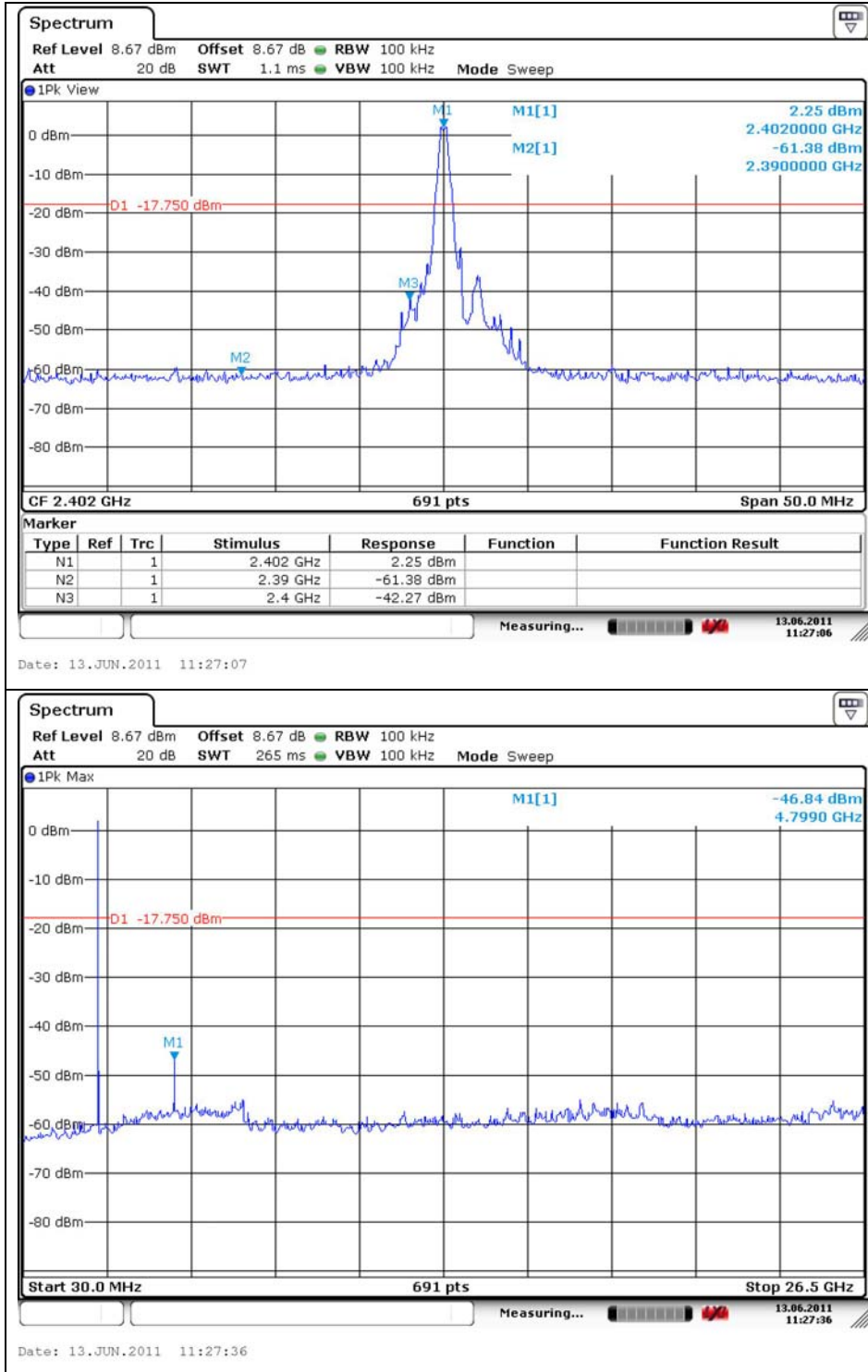

The results shown in this test report refer only to the sample(s) tested unless otherwise stated. This test report cannot be reproduced, except in full, without prior written permission of the Company.

Middle Channel

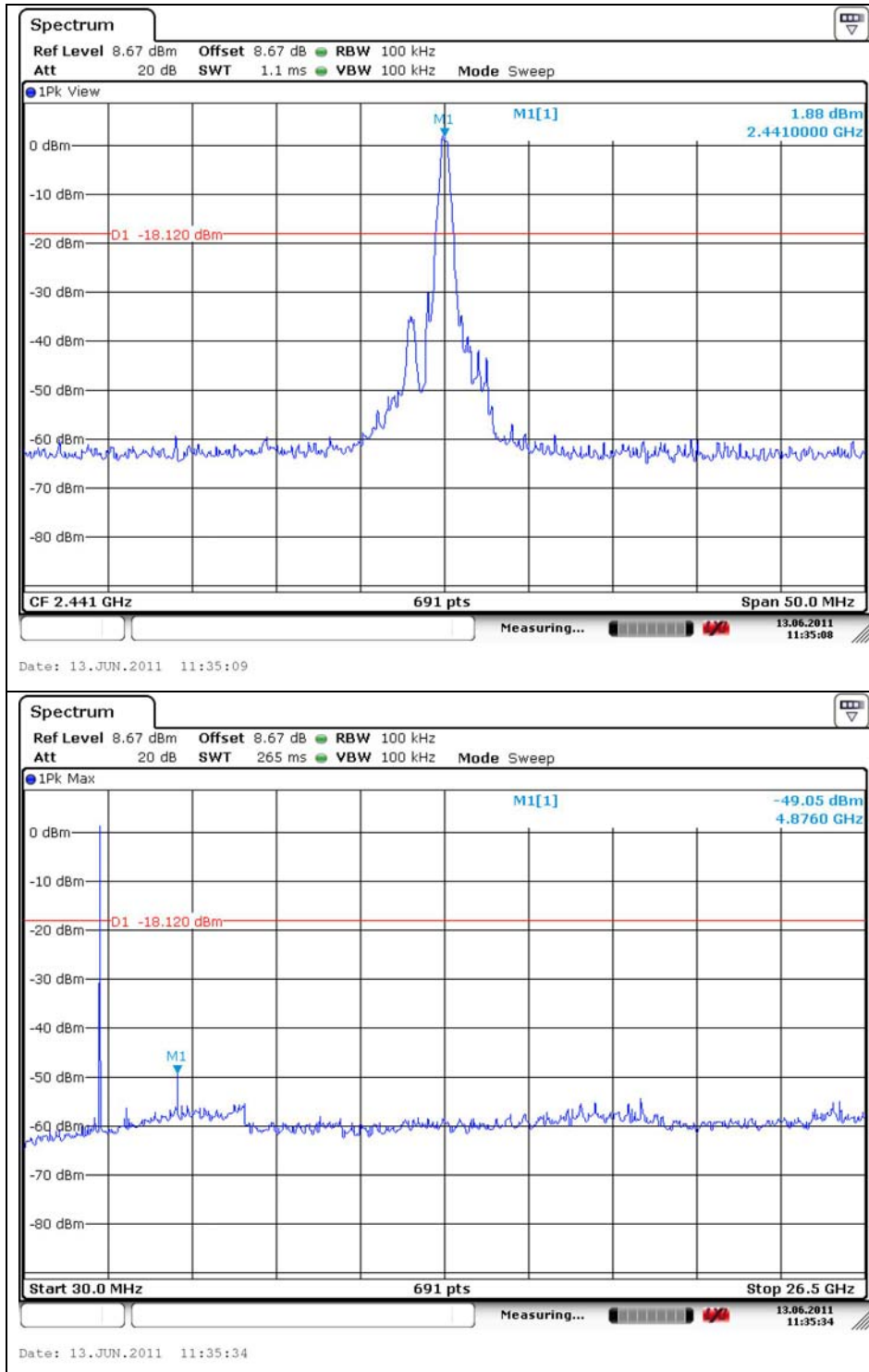

The results shown in this test report refer only to the sample(s) tested unless otherwise stated. This test report cannot be reproduced, except in full, without prior written permission of the Company.

High Channel

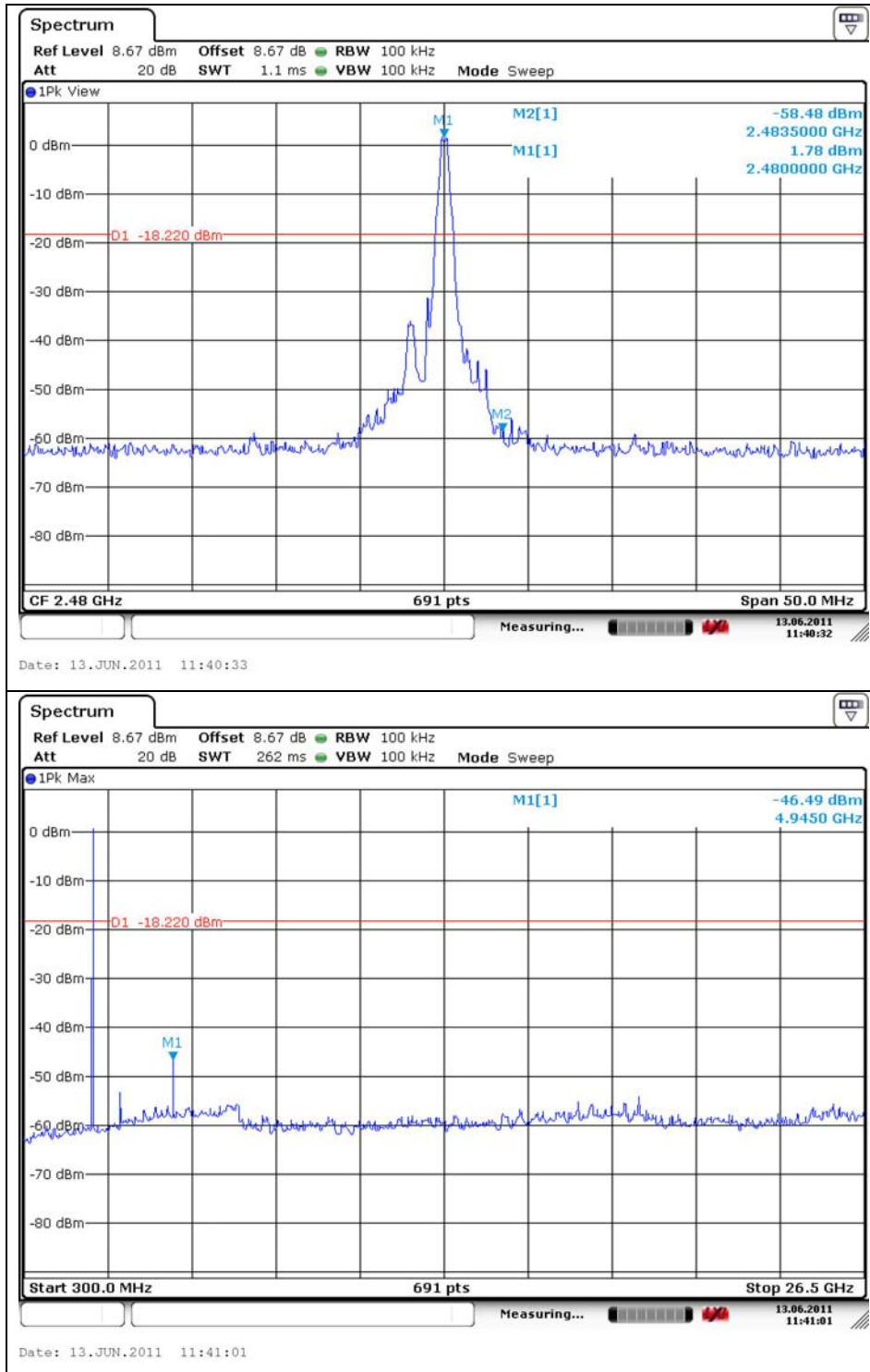

The results shown in this test report refer only to the sample(s) tested unless otherwise stated. This test report cannot be reproduced, except in full, without prior written permission of the Company.

Bandedge at Hopping

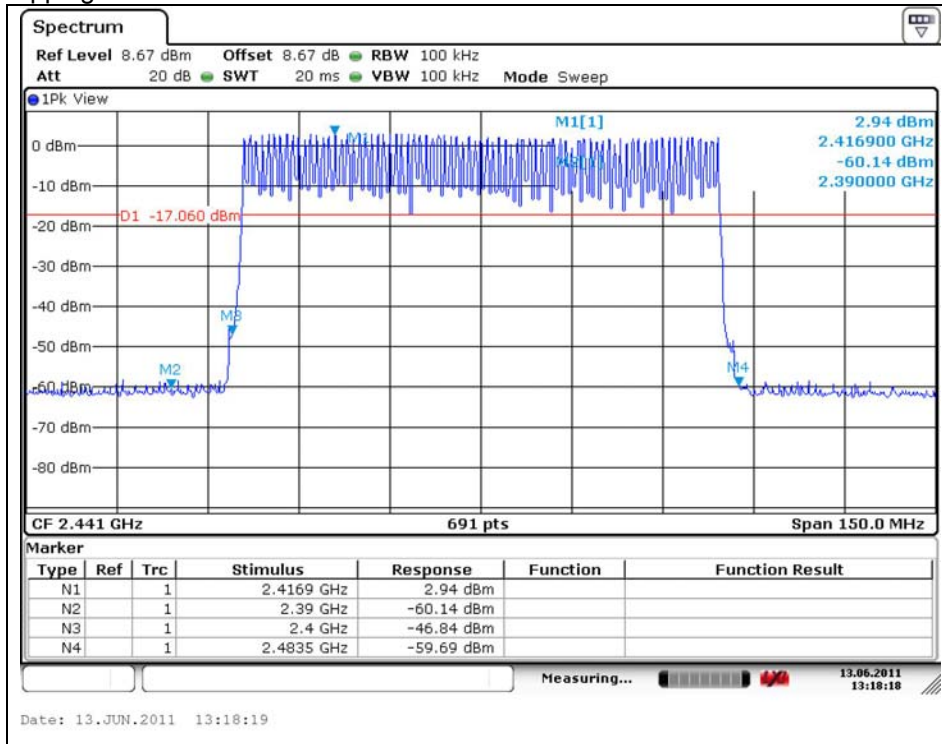

The results shown in this test report refer only to the sample(s) tested unless otherwise stated. This test report cannot be reproduced, except in full, without prior written permission of the Company.

## Operating Mode: 8DPSK (Micro USB)

Low Channel

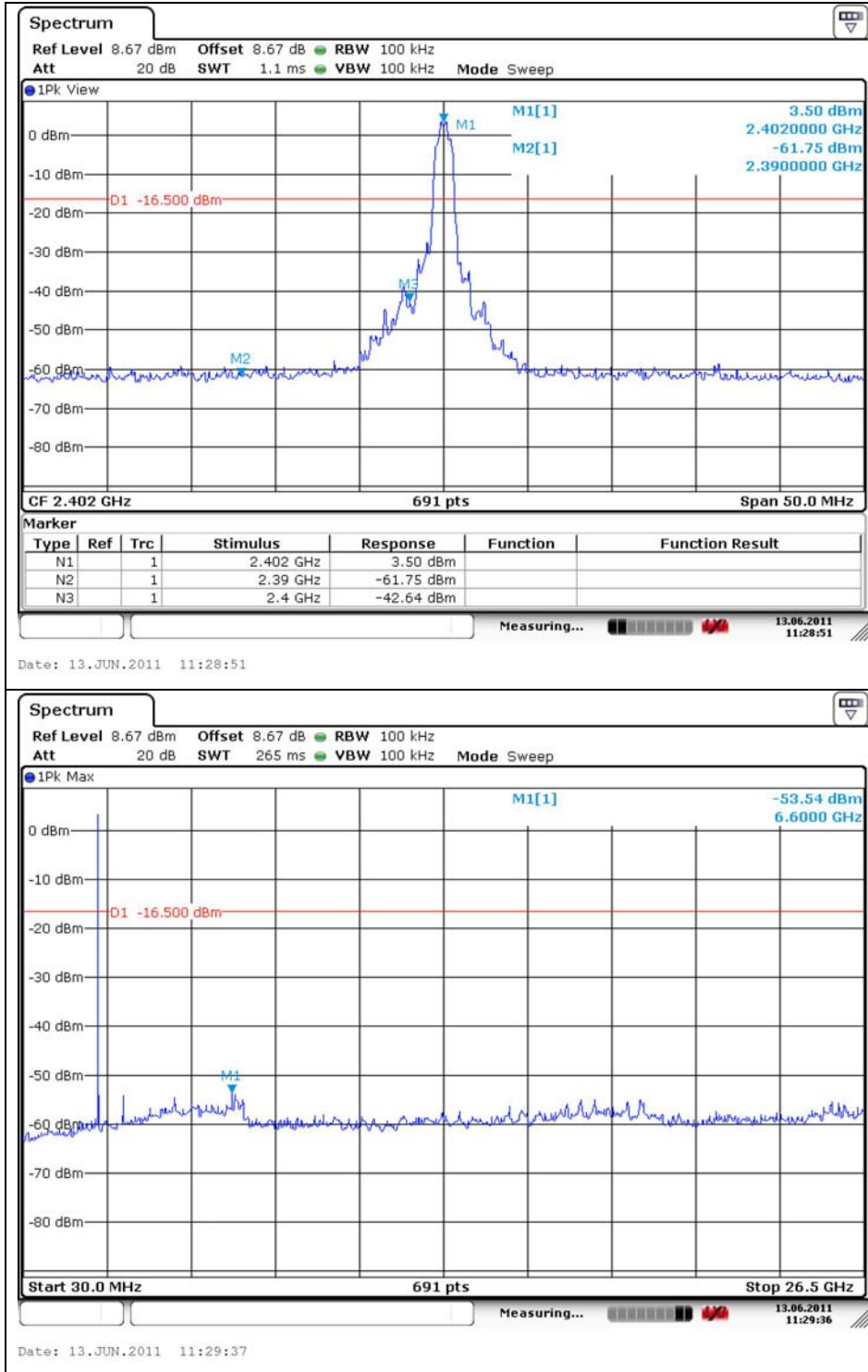

The results shown in this test report refer only to the sample(s) tested unless otherwise stated. This test report cannot be reproduced, except in full, without prior written permission of the Company.

Middle Channel

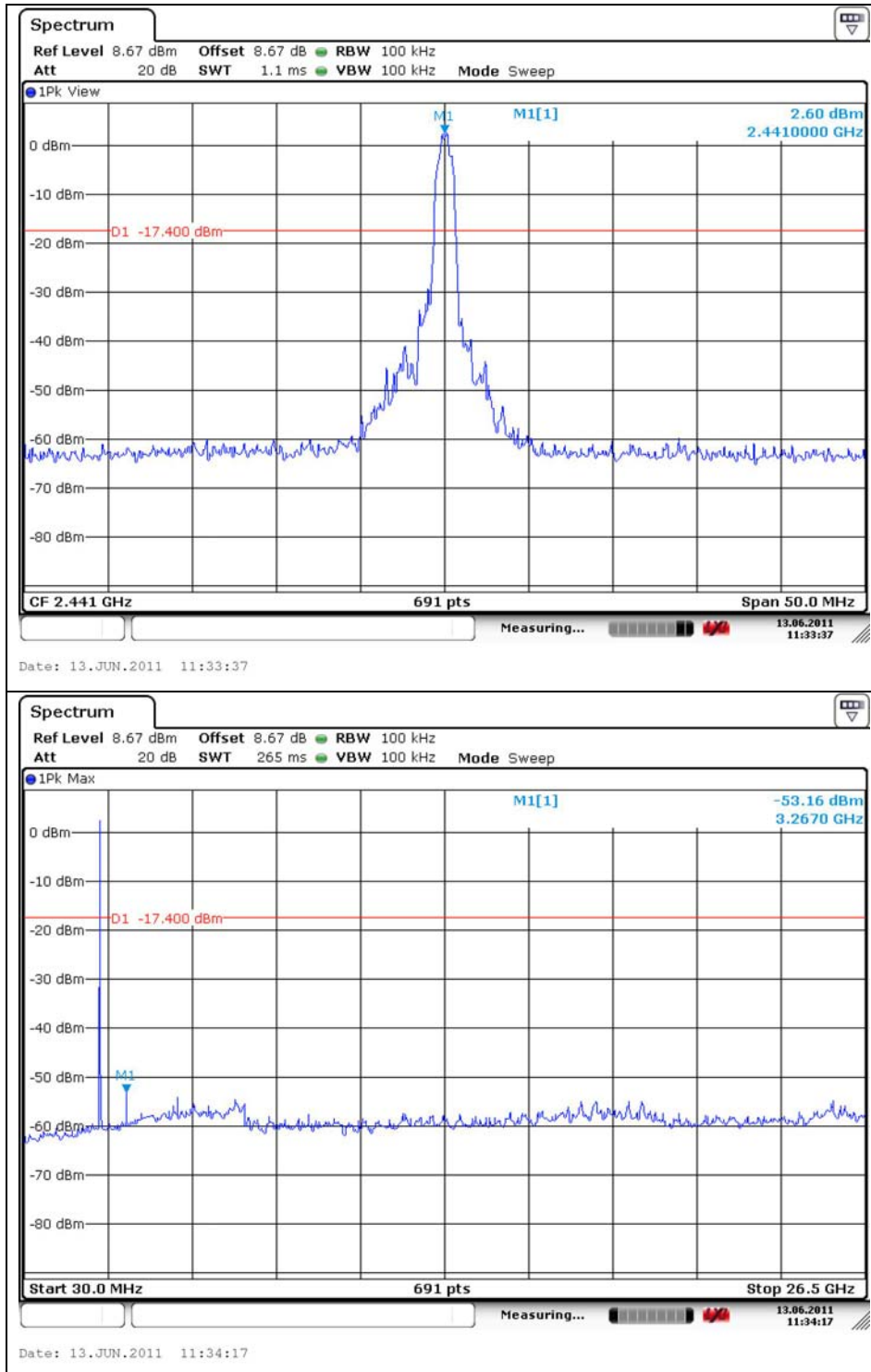

The results shown in this test report refer only to the sample(s) tested unless otherwise stated. This test report cannot be reproduced, except in full, without prior written permission of the Company.

High Channel

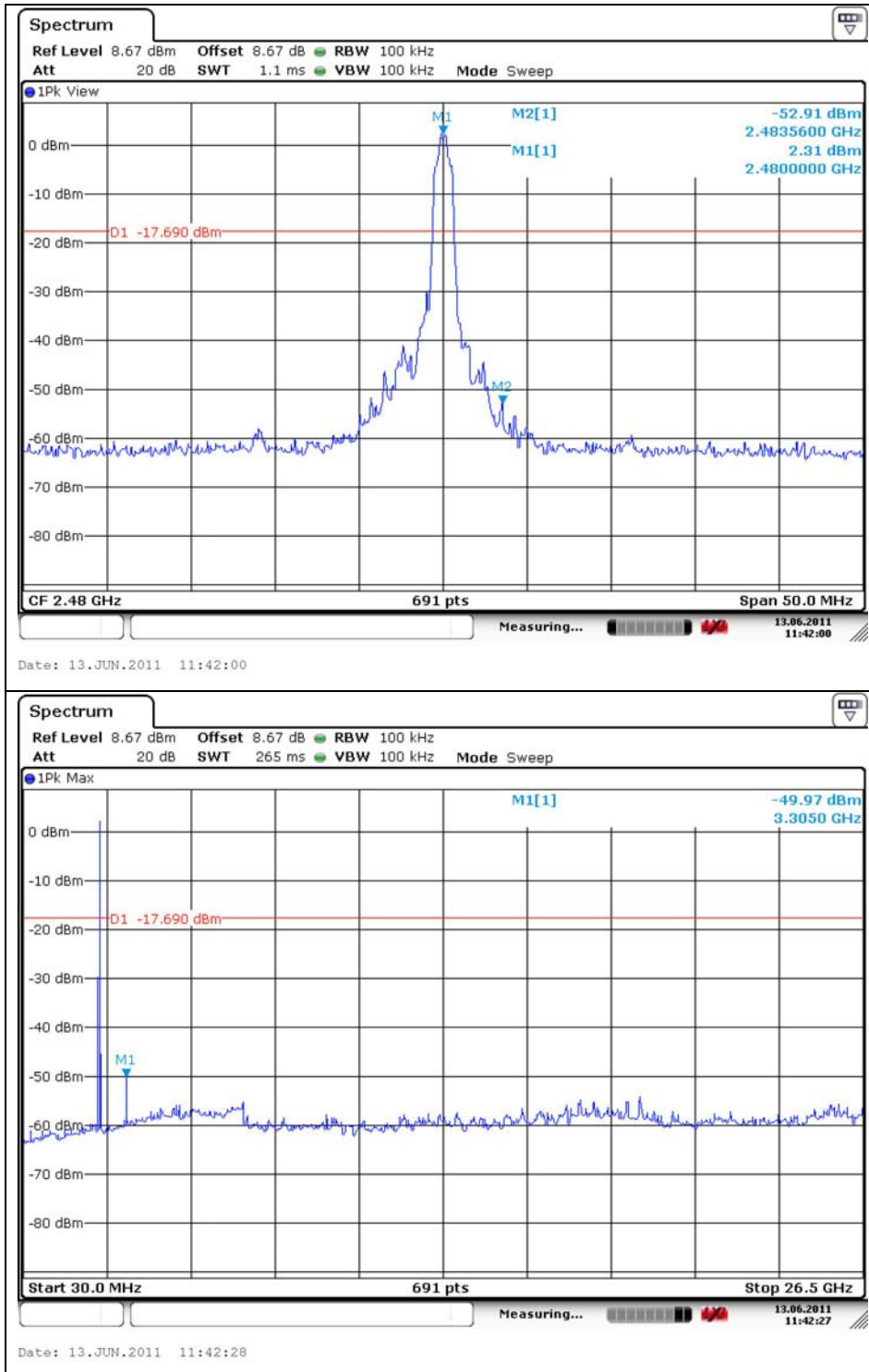

The results shown in this test report refer only to the sample(s) tested unless otherwise stated. This test report cannot be reproduced, except in full, without prior written permission of the Company.

Bandedge at Hopping

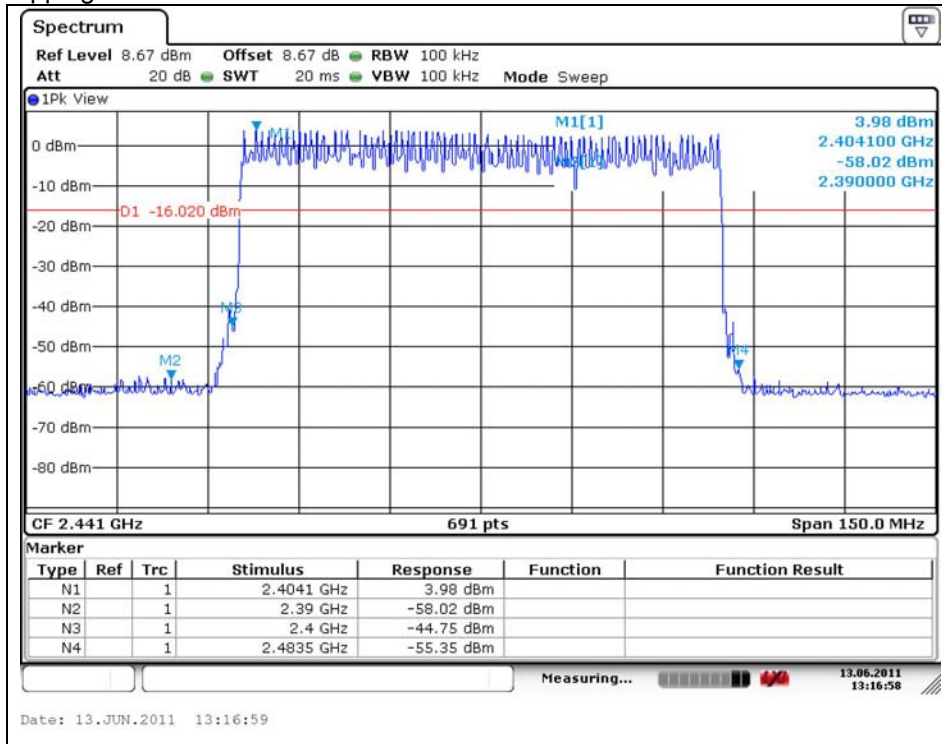

The results shown in this test report refer only to the sample(s) tested unless otherwise stated. This test report cannot be reproduced, except in full, without prior written permission of the Company.

### 3. Receiver Radiated spurious emissions

#### 3.1. Test setup - Same as clause 2.1.

##### 3.1.1. Receiver Radiated Spurious Emissions - Same as clause 2.1.1.

#### 3.2. Limit

According to §15.109(a), Except for Class A digital devices, the field strength of radiated emission from unintentional radiator at a distance of 3 m shall not exceed the following values:

Frequency (MHz)	Distance (Meters)	Radiated (dB $\mu$ V/m)	Radiated ( $\mu$ V/m)
30 - 88	3	40.0	100
88 – 216	3	43.5	150
216 – 960	3	46.0	200
Above 960	3	54.0	500

#### 3.3. Test Procedures - Same as clause 2.3.

Radiated emissions from the EUT were measured according to the dictates of ANSI C63.4:2003

##### 3.3.1. Test Procedures for Radiated Spurious Emissions- Same as clause 2.3.1.

*The results shown in this test report refer only to the sample(s) tested unless otherwise stated. This test report cannot be reproduced, except in full, without prior written permission of the Company.*

### 3.4. Test Results

Ambient temperature : (23 ± 2) °C  
 Relative humidity : 47 % R.H.

#### 3.4.1. Spurious Radiated Emission (Worst case configuration Micro USB)

The frequency spectrum from 30 MHz to 26.5 GHz was investigated. Emission levels are not reported much lower than the limits by over 30 dB. All reading values are peak values.

Radiated Emissions			Ant	Correction Factors		Total	FCC Limit	
Frequency (MHz)	Reading (dB $\mu$ V)	Detect Mode	Pol.	AF (dB/m)	AMP + CL (dB)	Actual (dB $\mu$ V/m)	Limit (dB $\mu$ V/m)	Margin (dB)
160.020	38.60	Peak	H	8.19	-26.16	20.63	43.50	22.87
167.928	37.26	Peak	H	8.45	-26.80	19.63	43.50	23.87
398.236	36.12	Peak	H	16.05	-25.53	26.64	46.00	19.36
399.974	39.00	Peak	H	16.09	-25.54	29.55	46.00	16.45
Above 400.000	Not Detected	-	-	-	-	-	-	-

#### Remark:

1. All spurious emission at channels are almost the same from 30 MHz to 26.5 GHz, so that the middle channel was chosen at representative in final test.
2. Actual = Reading + AF + AMP + CL  
The field strength of spurious emission was measured in three orthogonal EUT positions(x-axis, y-axis and z-axis). Worst case is y-axis.
- 3.

The results shown in this test report refer only to the sample(s) tested unless otherwise stated. This test report cannot be reproduced, except in full, without prior written permission of the Company.

## 4. 20 dB Bandwidth Measurement and 99 % BW

### 4.1. Test Setup

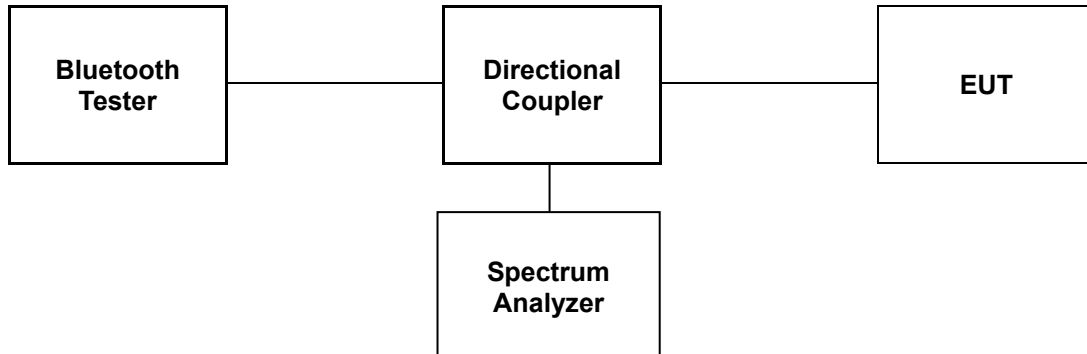

### 4.2. Limit

Limit: Not Applicable

### 4.3. Test Procedure

1. The 20 dB band width was measured with a spectrum analyzer connected to RF antenna connector(conducted measurement) while EUT was operating in transmit mode at the appropriate center frequency. The analyzer center frequency was set to the EUT carrier frequency, using the analyzer. Display Line and Marker Delta functions, the 20 dB band width of the emission was determined.
2. The bandwidth of the fundamental frequency was measured with the spectrum analyzer using RBW = 20 kHz, VBW = 20 kHz, Span = 5 MHz.

*The results shown in this test report refer only to the sample(s) tested unless otherwise stated. This test report cannot be reproduced, except in full, without prior written permission of the Company.*

#### 4.4. Test Results

Ambient temperature : (23 ± 2) °C

Relative humidity : 47 % R.H.

**Power source : Inner battery**

Operation Mode	Channel	Channel Frequency (MHz)	20 dB Bandwidth (MHz)	99 % Bandwidth (MHz)
GFSK	Low	2 402	0.80	0.82
	Middle	2 441	0.79	0.82
	High	2 480	0.79	0.81
8DPSK	Low	2 402	1.22	1.14
	Middle	2 441	1.21	1.14
	High	2 480	1.21	1.14

**Power source : Micro USB**

Operation Mode	Channel	Channel Frequency (MHz)	20 dB Bandwidth (MHz)	99 % Bandwidth (MHz)
GFSK	Low	2 402	0.80	0.82
	Middle	2 441	0.78	0.81
	High	2 480	0.80	0.81
8DPSK	Low	2 402	1.21	1.14
	Middle	2 441	1.21	1.14
	High	2 480	1.22	1.14

*The results shown in this test report refer only to the sample(s) tested unless otherwise stated. This test report cannot be reproduced, except in full, without prior written permission of the Company.*

## 20 dB Bandwidth

### Operating Mode: GFSK (Inner battery)

#### Low Channel

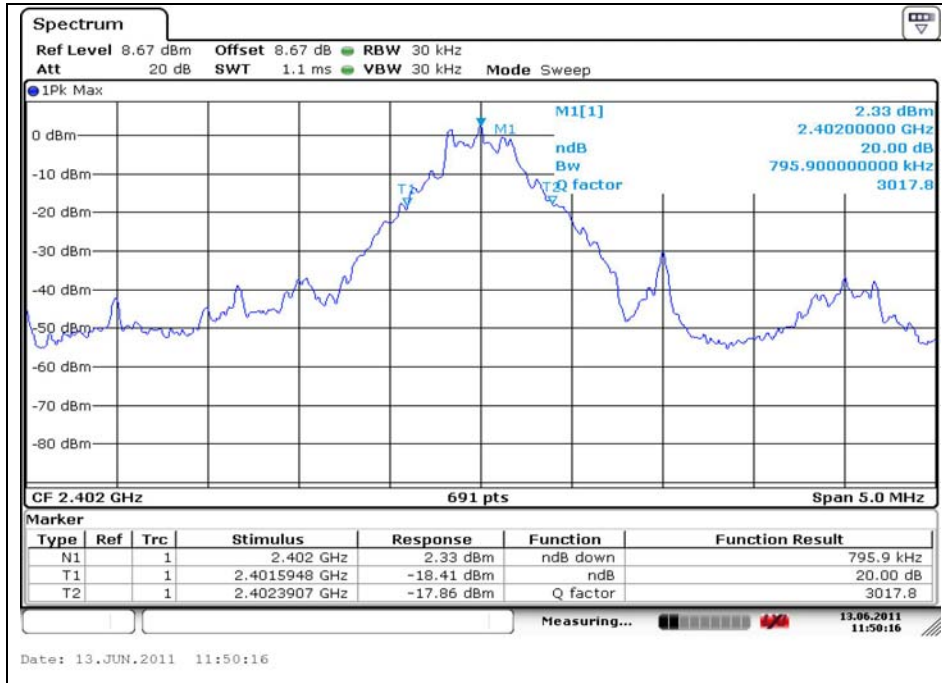

#### Middle Channel

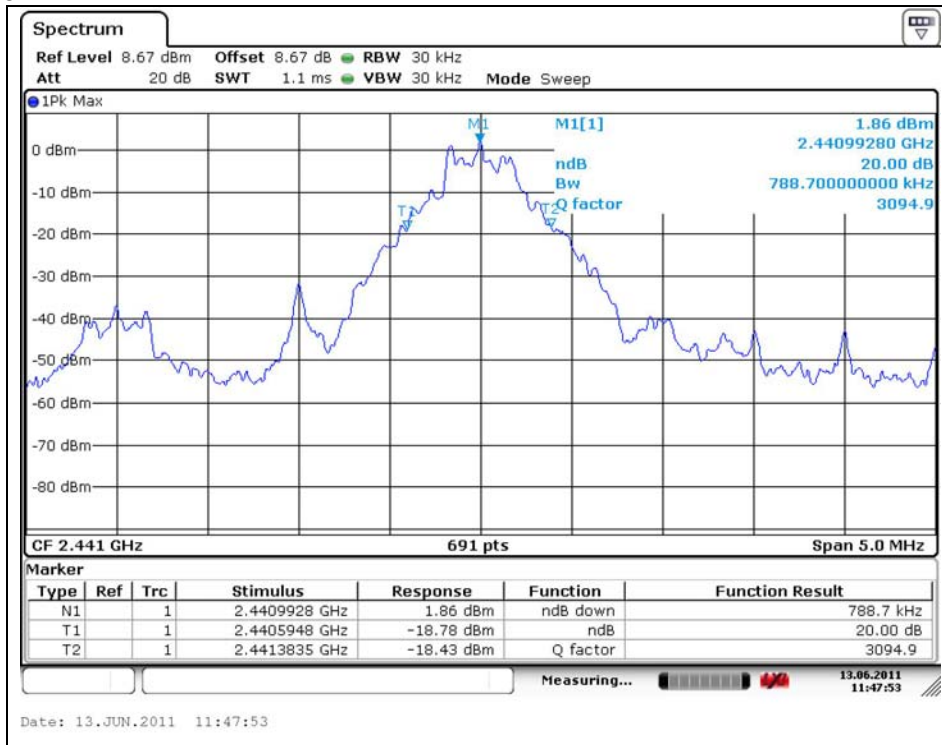

The results shown in this test report refer only to the sample(s) tested unless otherwise stated. This test report cannot be reproduced, except in full, without prior written permission of the Company.

High Channel

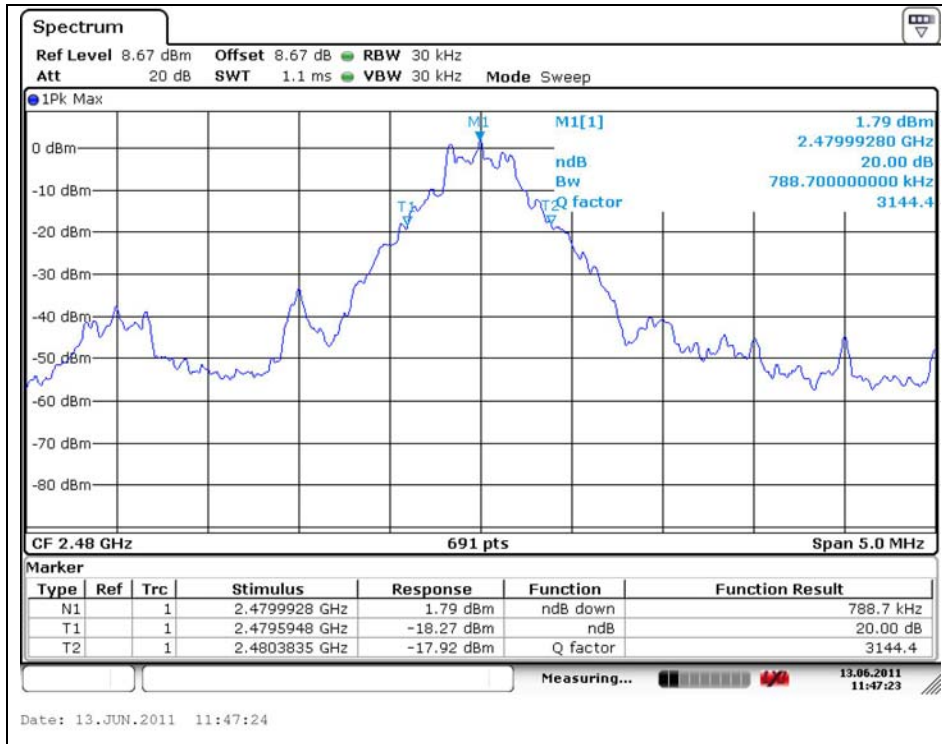

Operating Mode: 8DPSK (Inner battery)

Low Channel

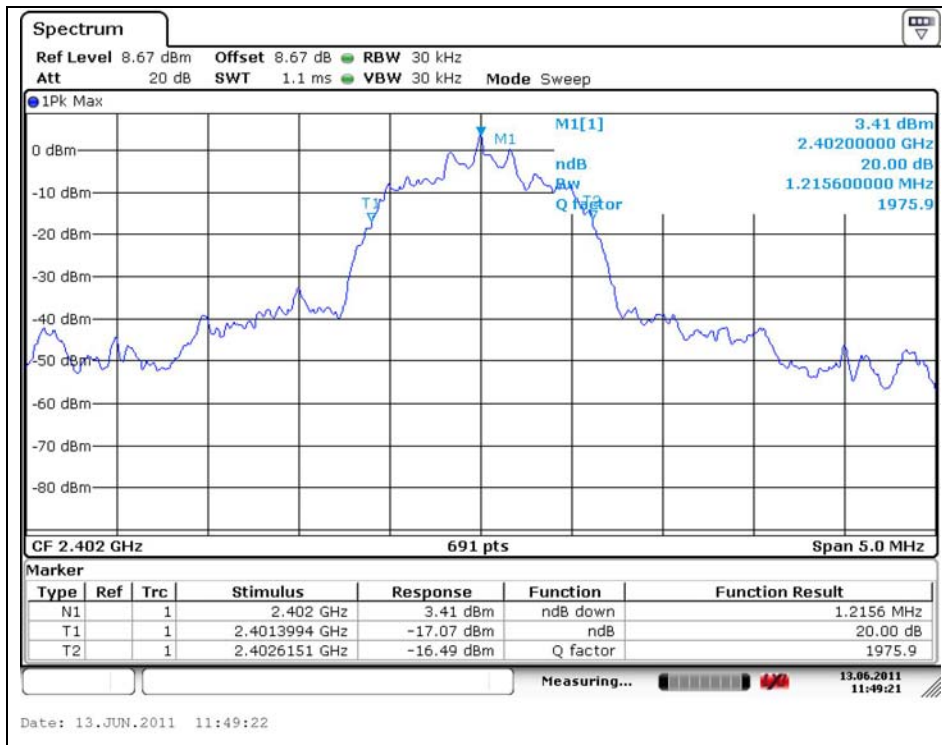

The results shown in this test report refer only to the sample(s) tested unless otherwise stated. This test report cannot be reproduced, except in full, without prior written permission of the Company.

Middle Channel

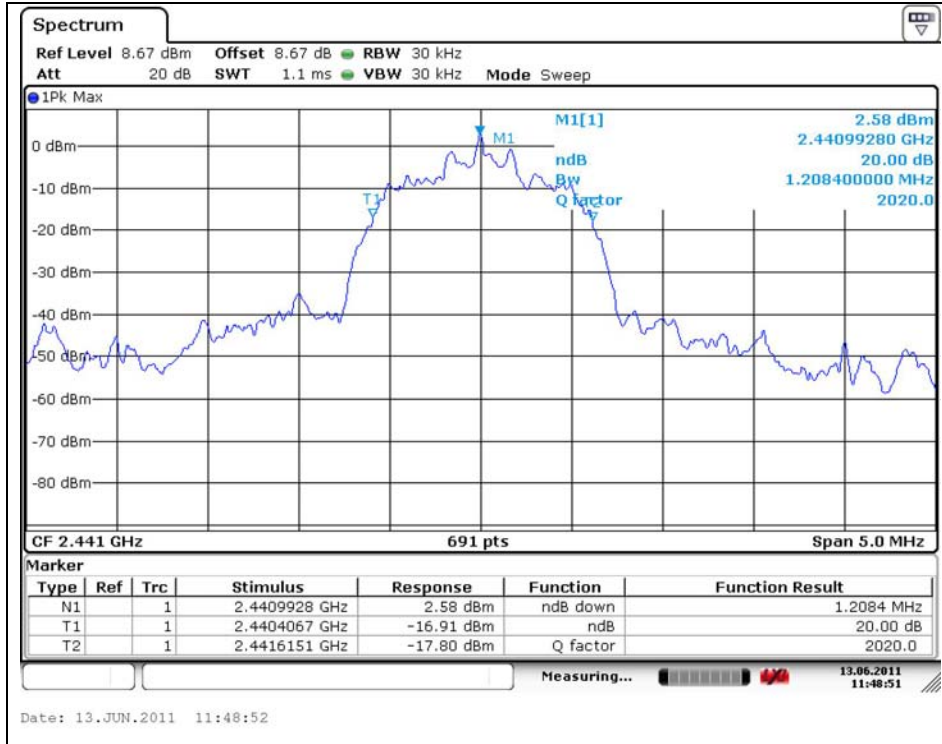

High Channel

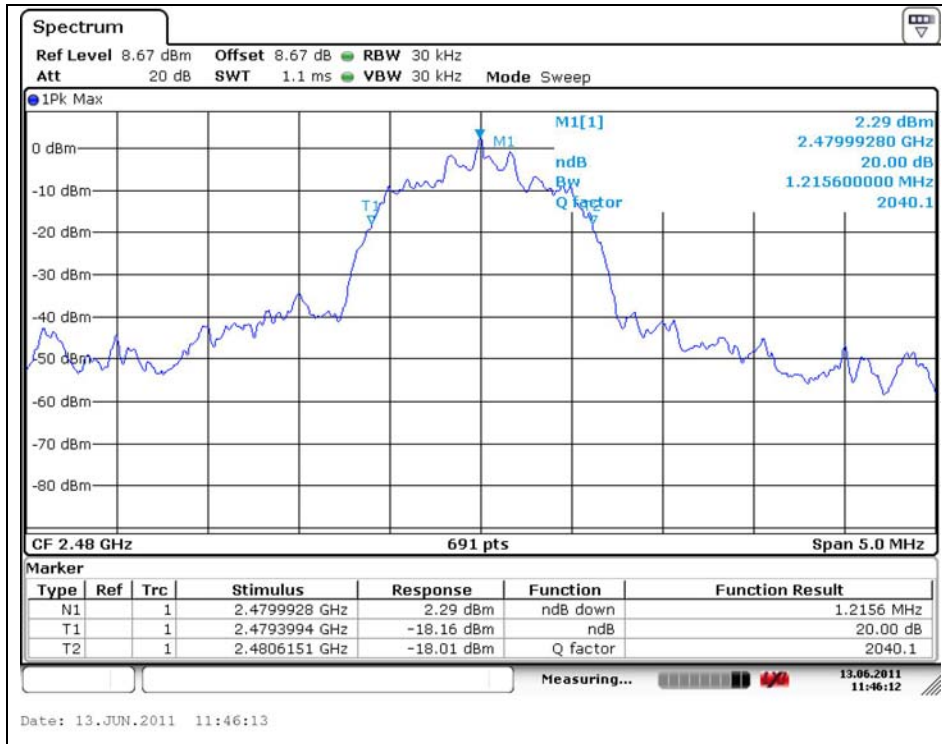

The results shown in this test report refer only to the sample(s) tested unless otherwise stated. This test report cannot be reproduced, except in full, without prior written permission of the Company.

**Operating Mode: GFSK (Micro USB)**

Low Channel

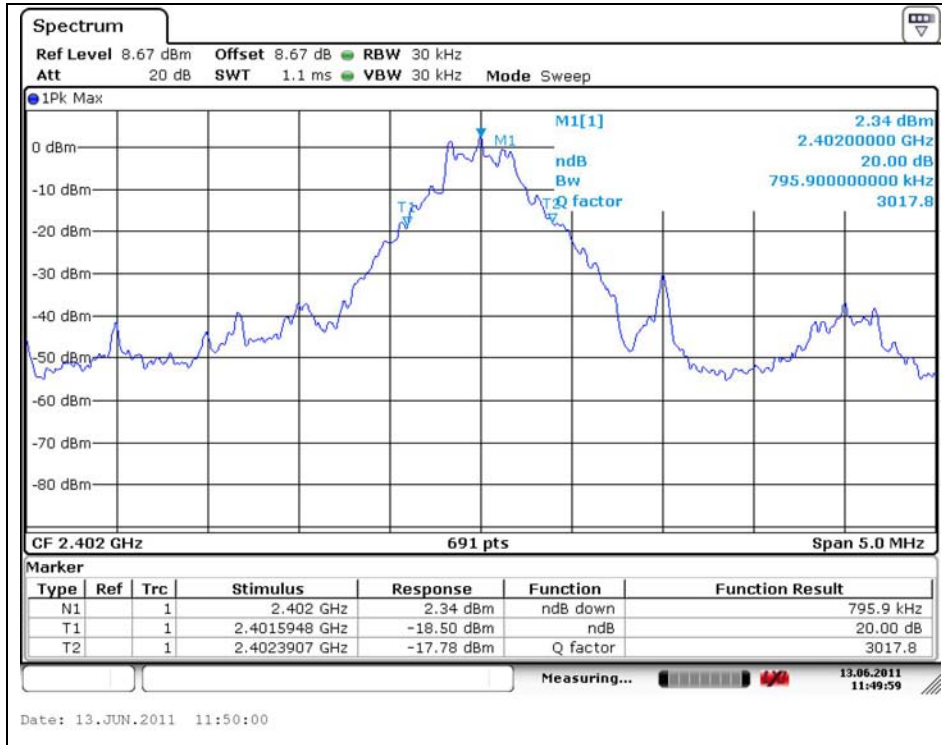

Middle Channel

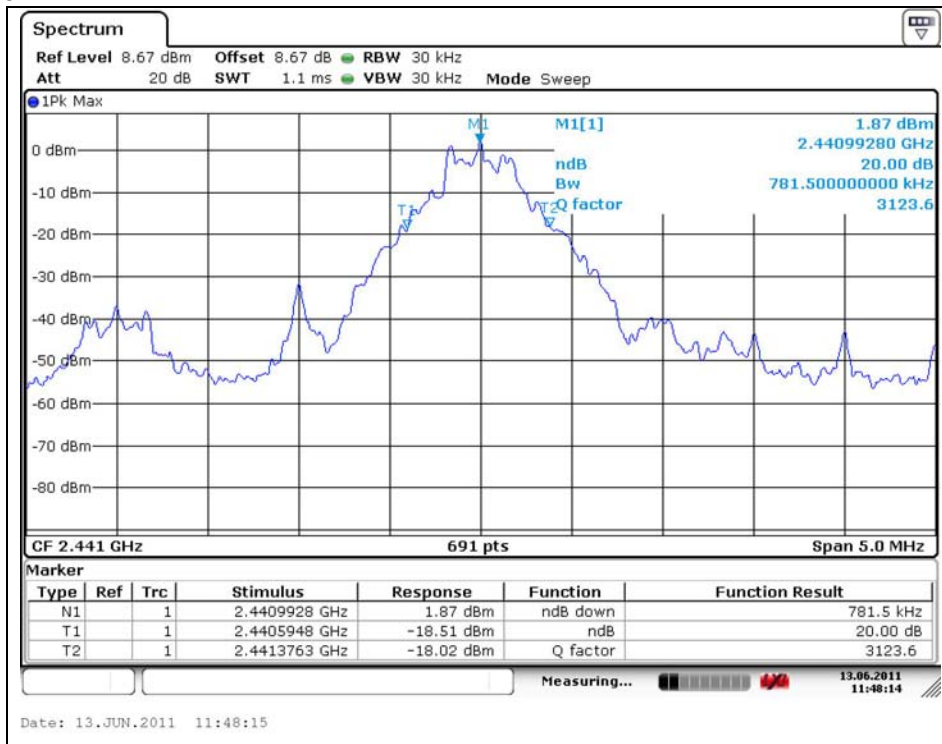

The results shown in this test report refer only to the sample(s) tested unless otherwise stated. This test report cannot be reproduced, except in full, without prior written permission of the Company.

Middle Channel

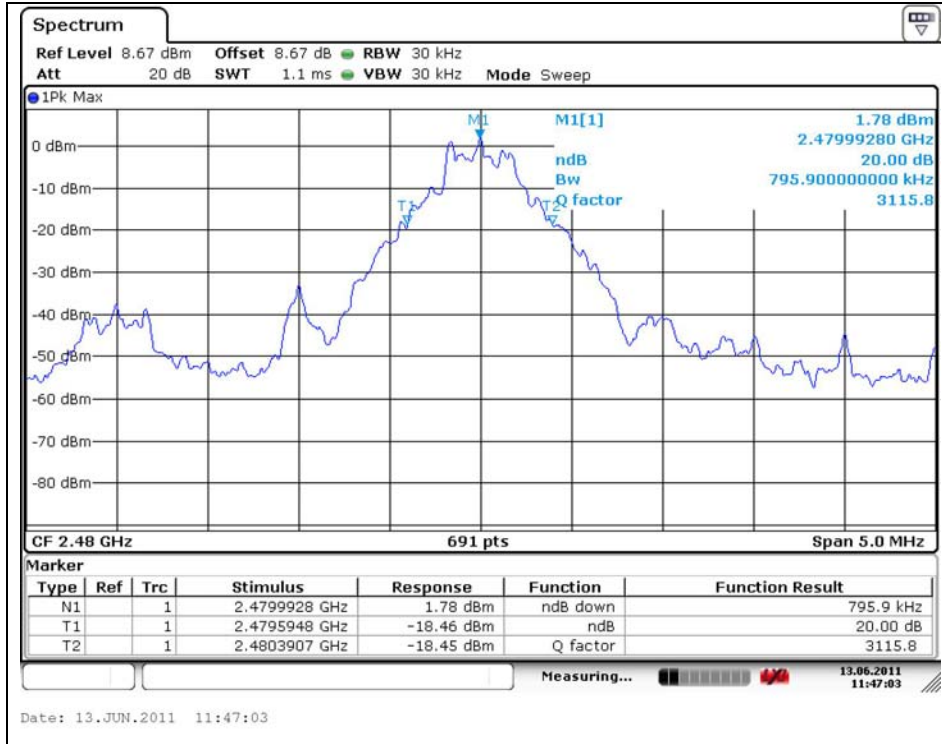

Operating Mode: 8DPSK (Micro USB)

Low Channel

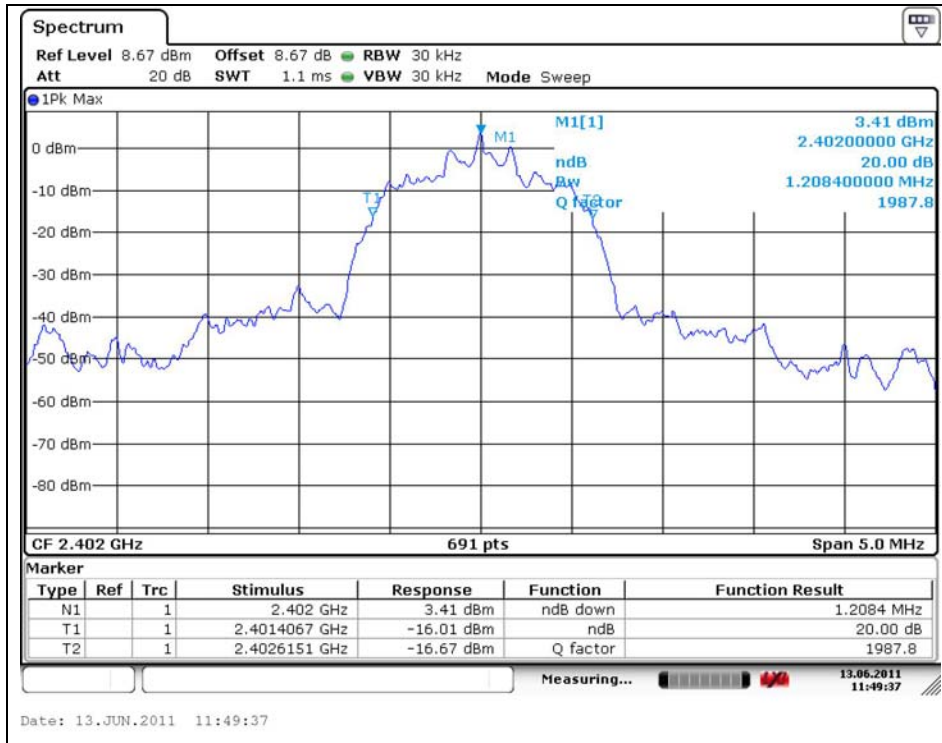

The results shown in this test report refer only to the sample(s) tested unless otherwise stated. This test report cannot be reproduced, except in full, without prior written permission of the Company.

Middle Channel

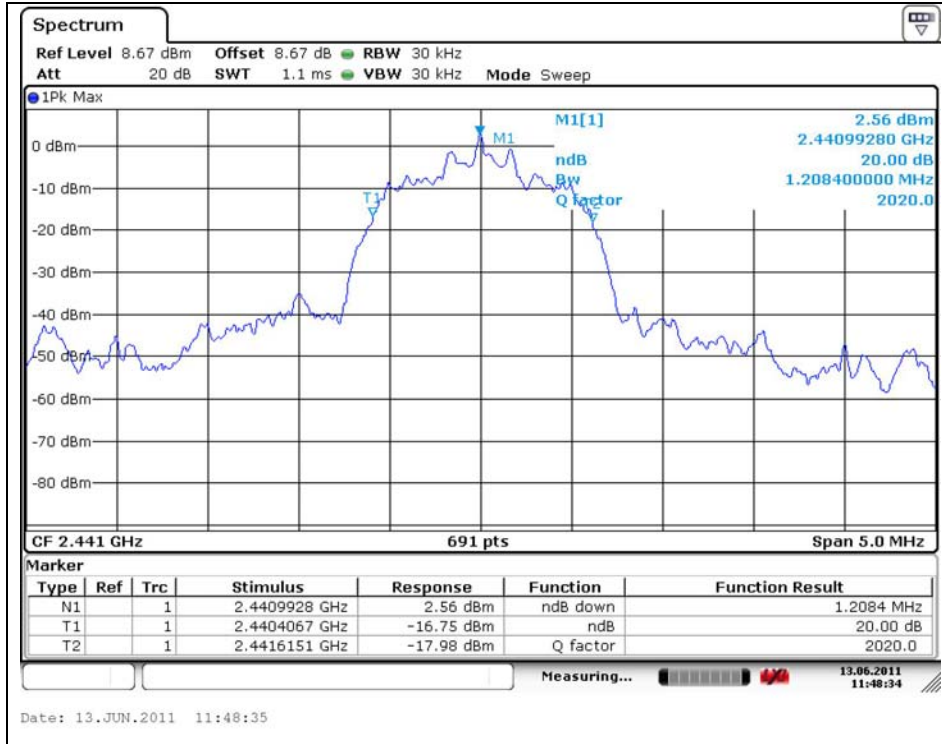

High Channel

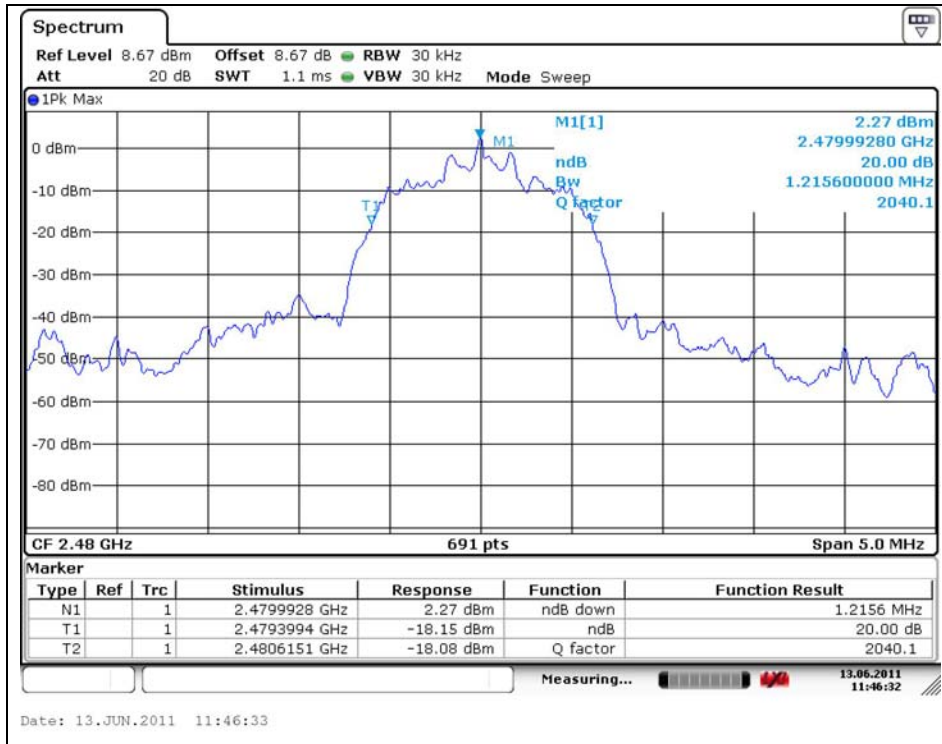

The results shown in this test report refer only to the sample(s) tested unless otherwise stated. This test report cannot be reproduced, except in full, without prior written permission of the Company.

**99% Bandwidth**  
**Operating Mode: GFSK (Micro USB)**  
 Low Channel

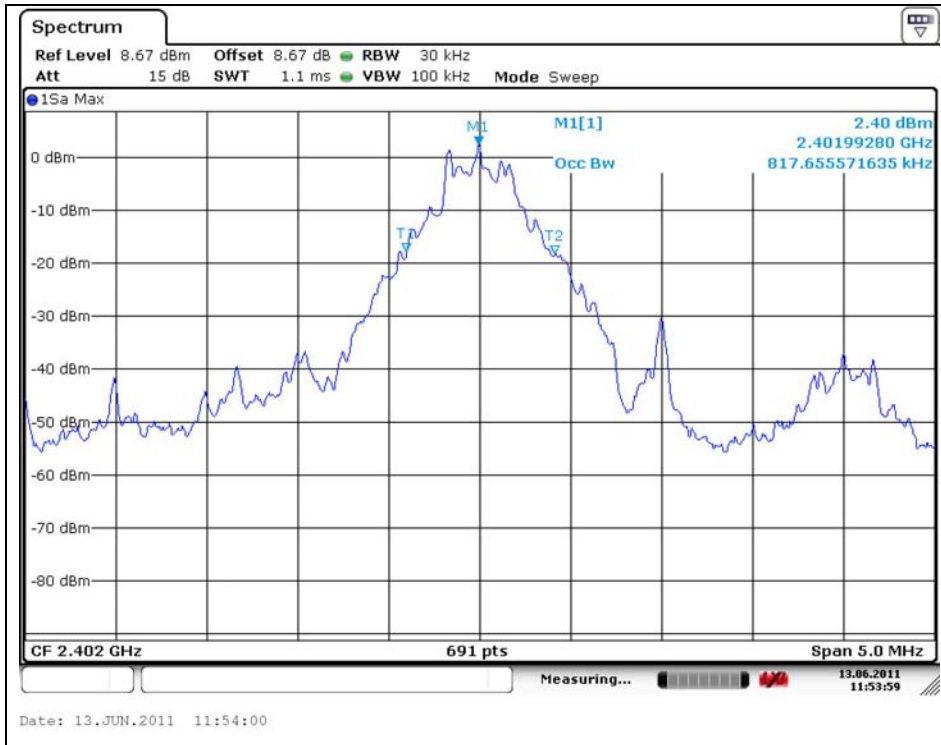

Middle Channel

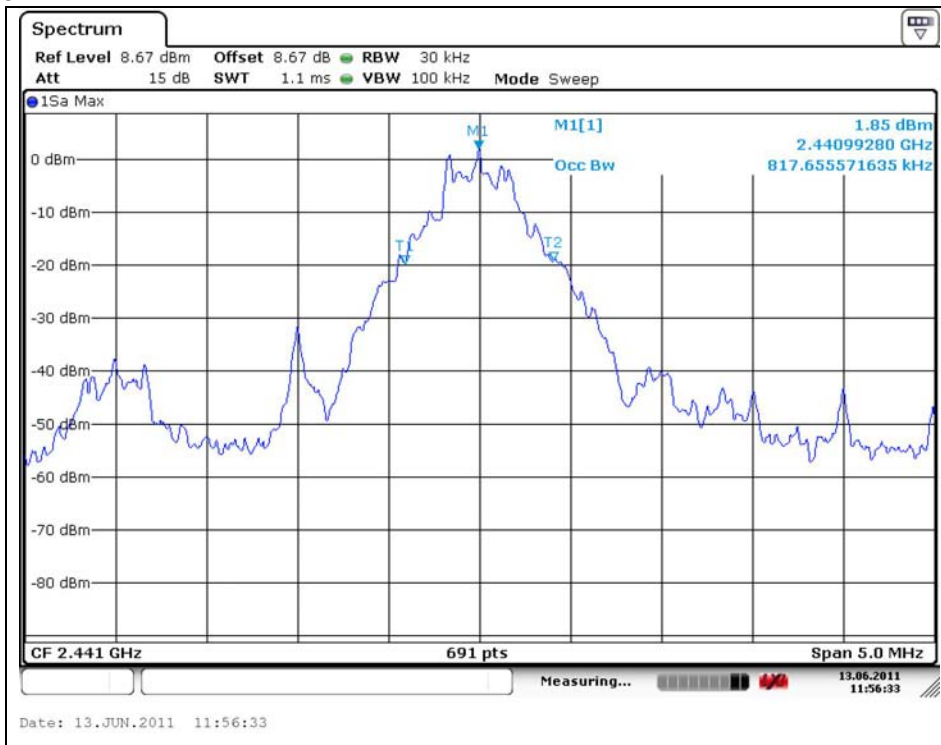

The results shown in this test report refer only to the sample(s) tested unless otherwise stated. This test report cannot be reproduced, except in full, without prior written permission of the Company.

High Channel

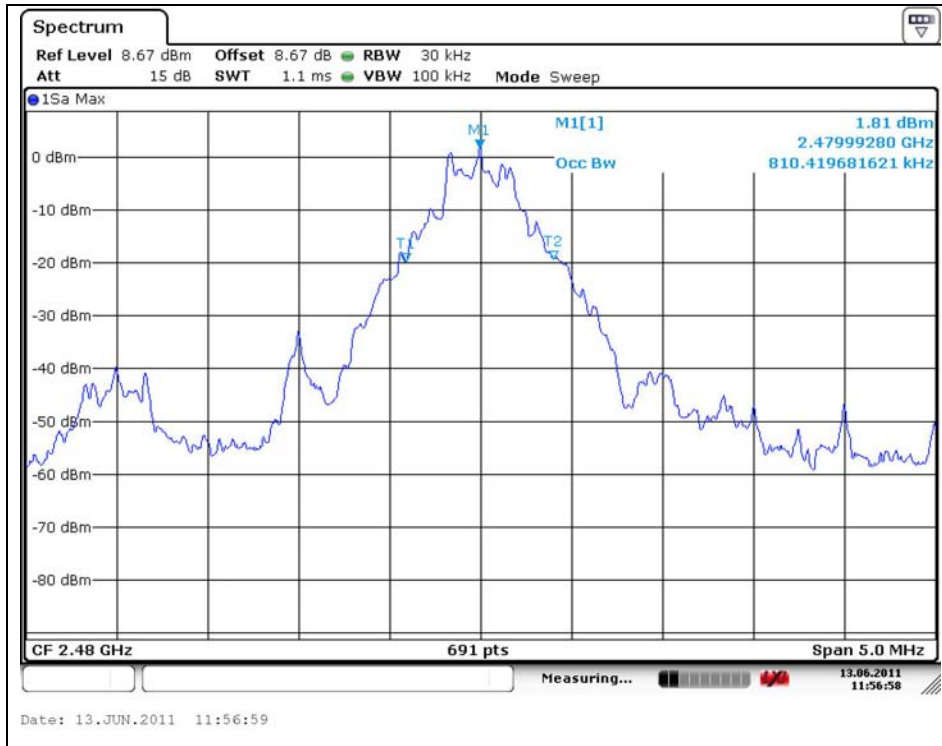

Operating Mode: 8DPSK (Inner battery)

Low Channel

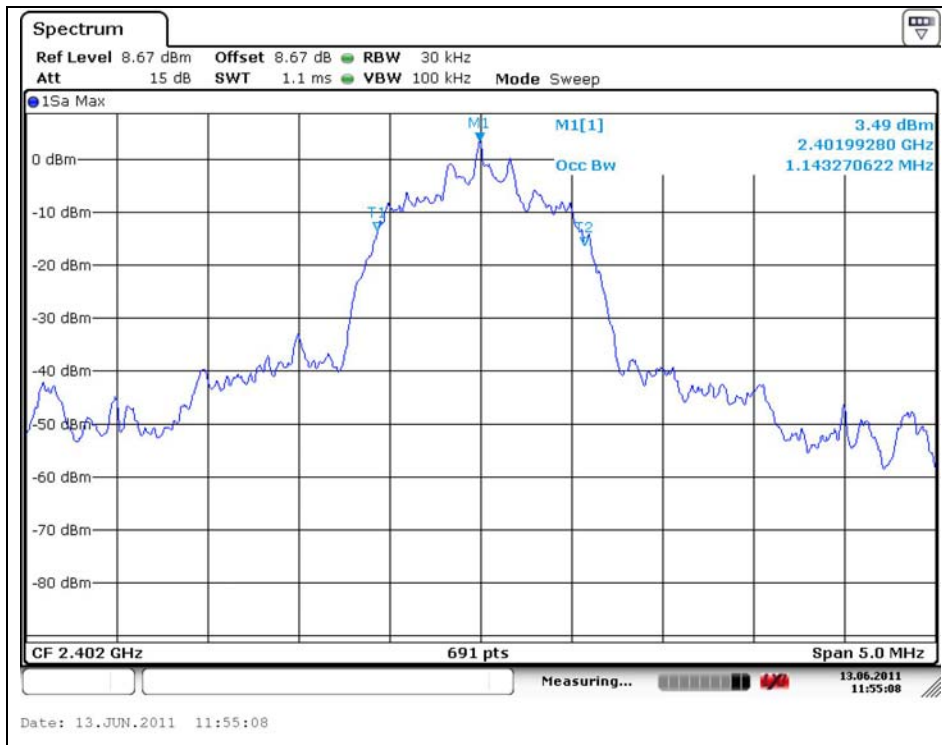

The results shown in this test report refer only to the sample(s) tested unless otherwise stated. This test report cannot be reproduced, except in full, without prior written permission of the Company.

Middle Channel

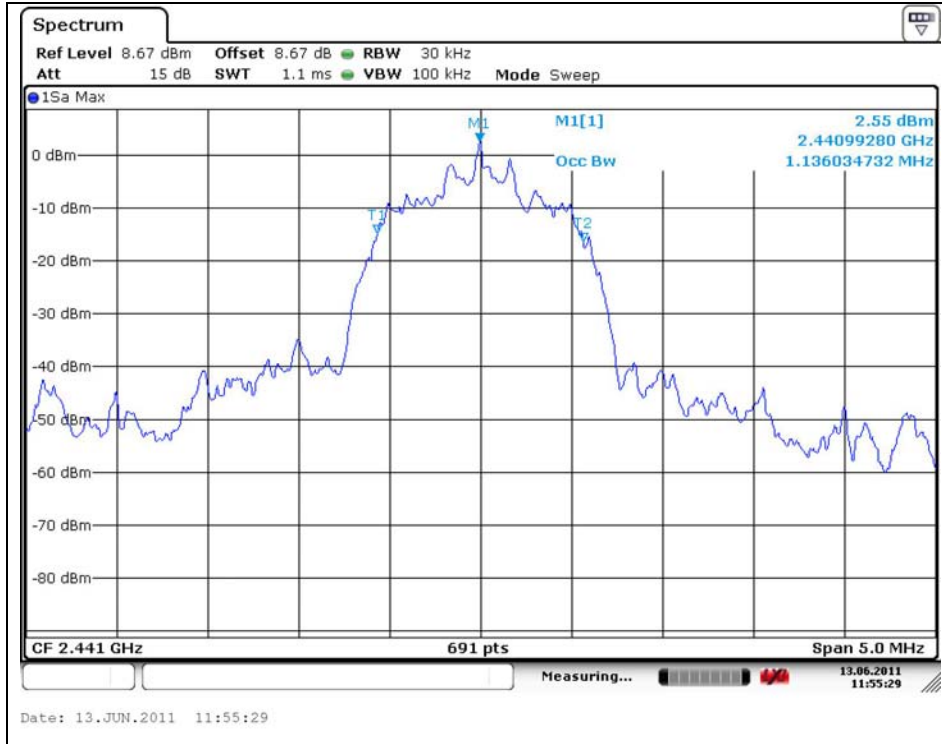

High Channel

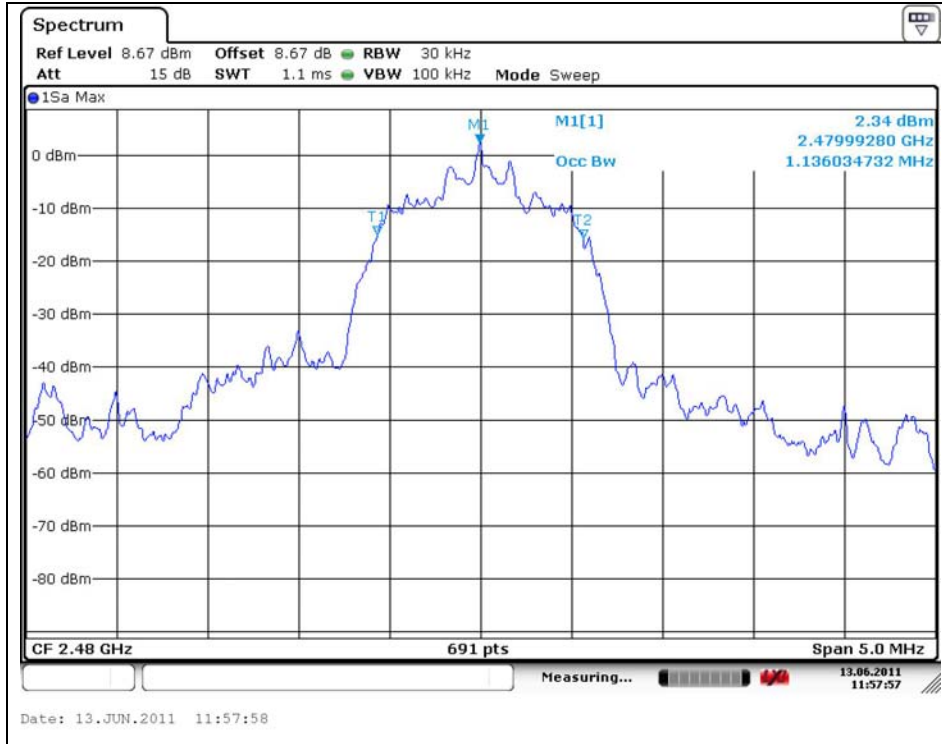

The results shown in this test report refer only to the sample(s) tested unless otherwise stated. This test report cannot be reproduced, except in full, without prior written permission of the Company.

**Operating Mode: GFSK (Micro USB)**

Low Channel

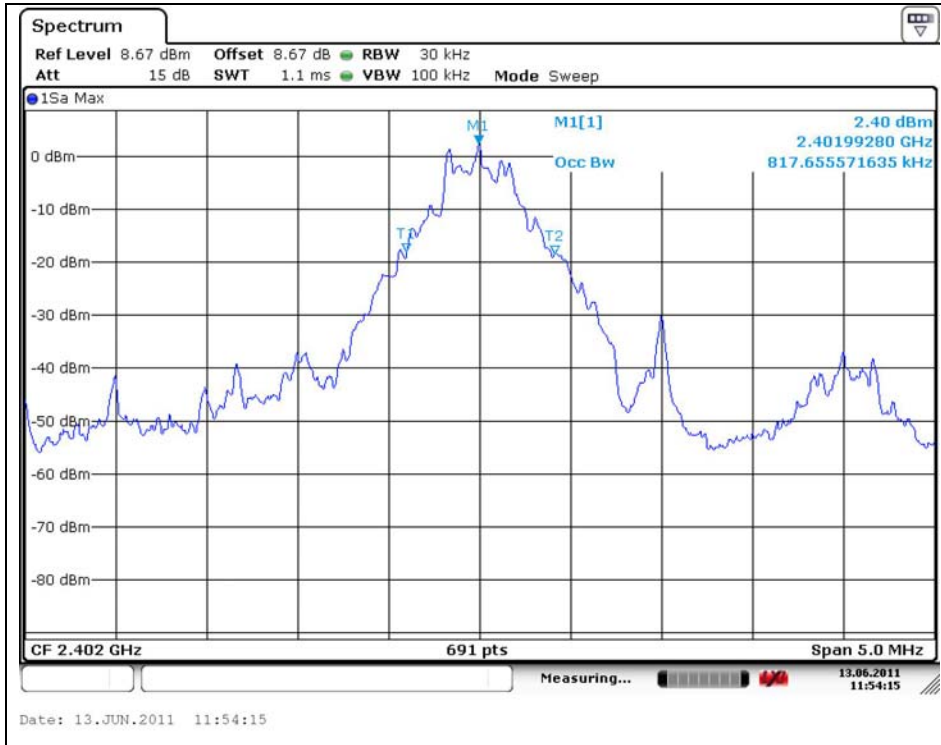

Middle Channel

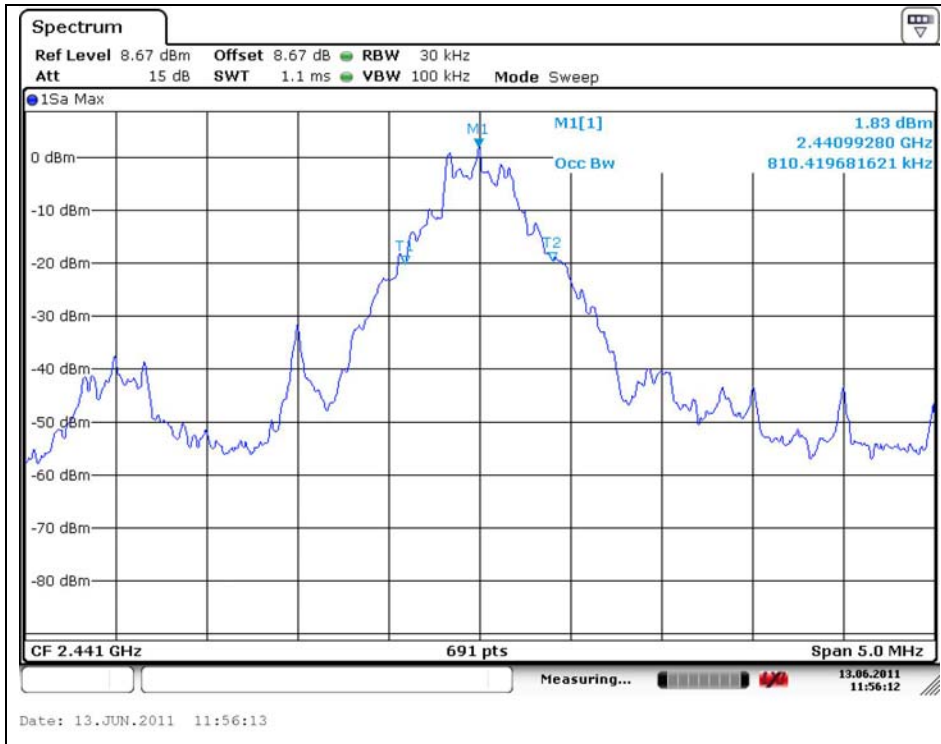

The results shown in this test report refer only to the sample(s) tested unless otherwise stated. This test report cannot be reproduced, except in full, without prior written permission of the Company.

High Channel

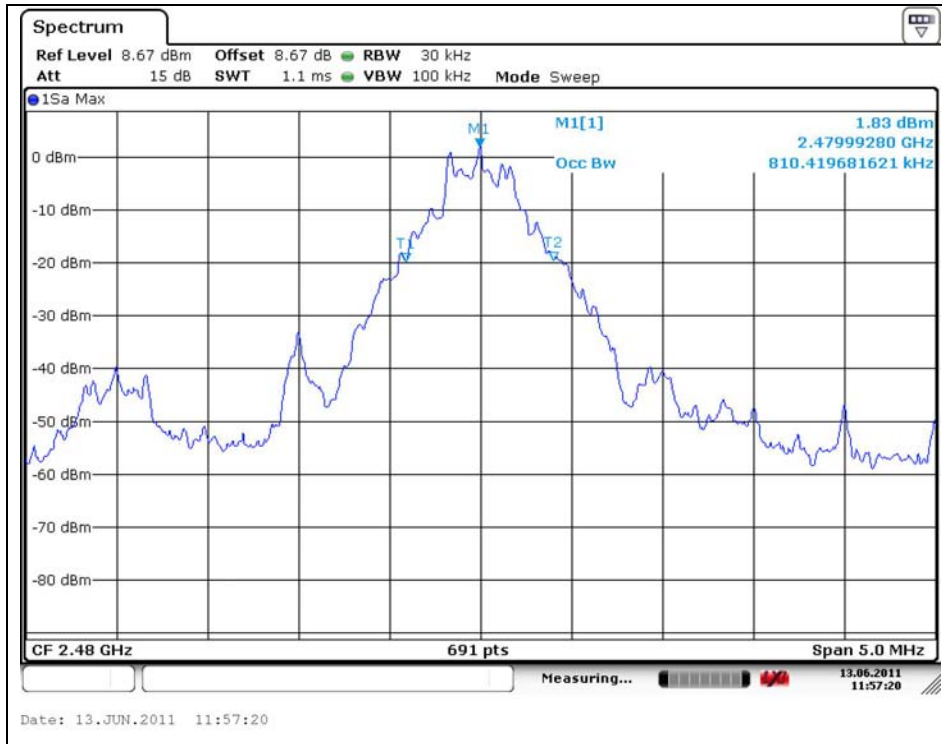

Operating Mode: 8DPSK (Micro USB)

Low Channel

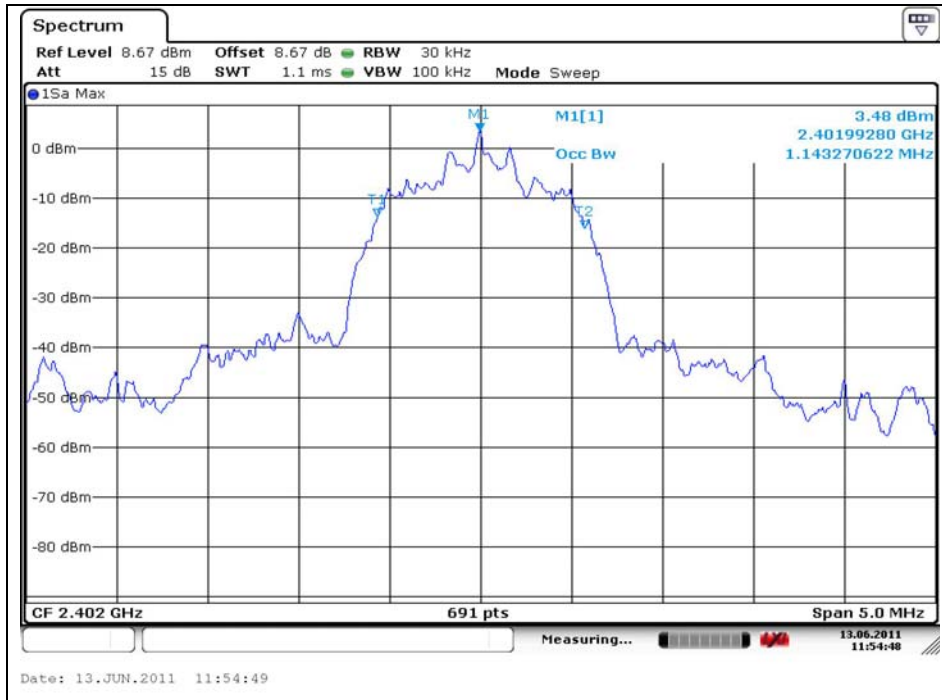

The results shown in this test report refer only to the sample(s) tested unless otherwise stated. This test report cannot be reproduced, except in full, without prior written permission of the Company.

Middle Channel

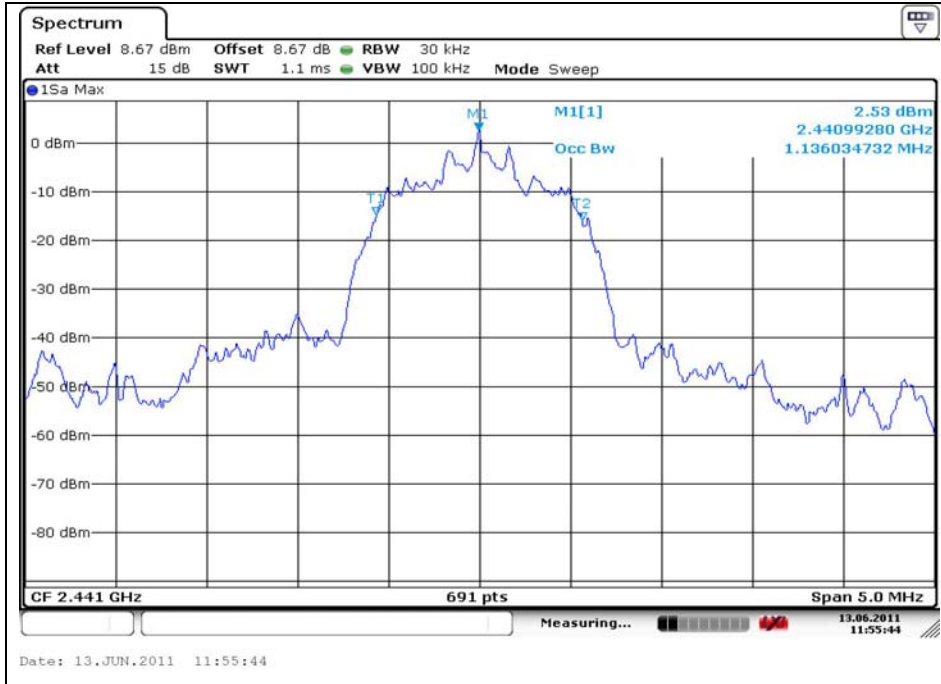

High Channel

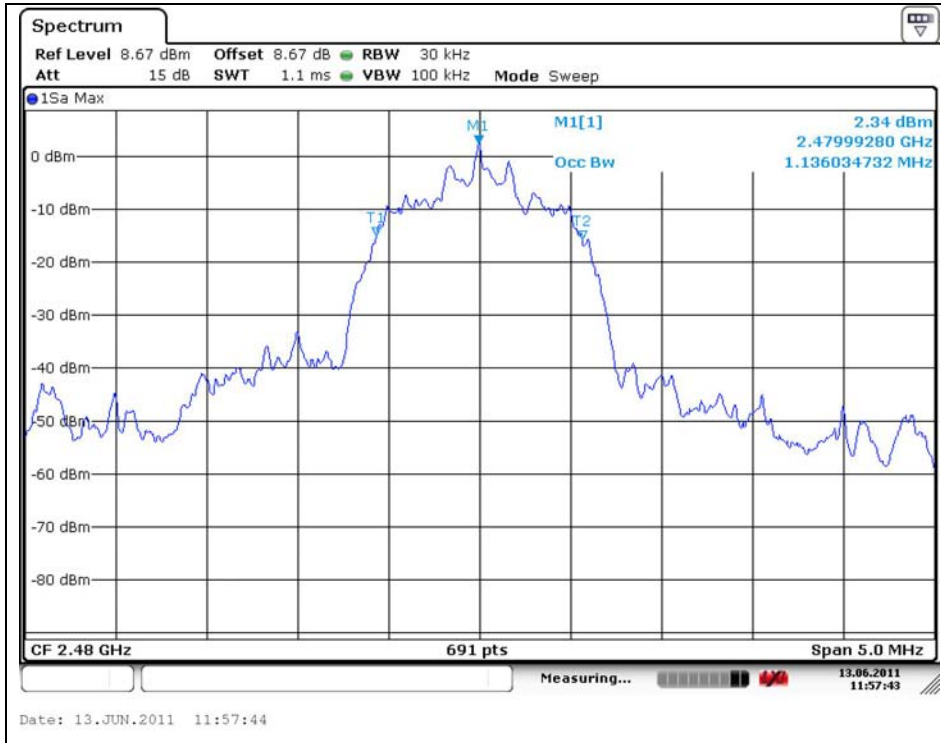

The results shown in this test report refer only to the sample(s) tested unless otherwise stated. This test report cannot be reproduced, except in full, without prior written permission of the Company.

## 5. Maximum Peak Output Power Measurement

### 5.1. Test Setup

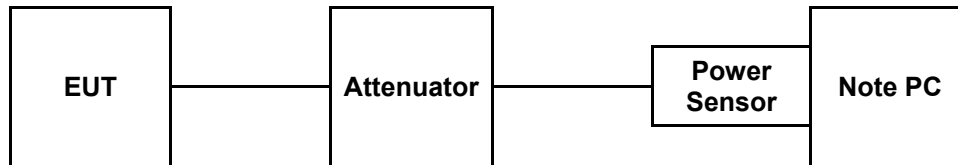

### 5.2. Limit

The maximum peak output power of the intentional radiator shall not exceed the following :

1. §15.247(a)(1), Frequency hopping systems shall have hopping channel carrier frequencies separated by a minimum of 25 kHz or the 20 dB bandwidth of the hopping channel, whichever is greater, provided the systems operate with an output power no greater than 125 mW.
2. §15.247(b)(1), For frequency hopping systems operating in the 2 400 – 2 483.5 MHz employing at least 75 non-overlapping hopping channels, and all frequency hopping systems in the 5 725 – 5 805 MHz band: 1 Watt.

### 5.3. Test Procedure

1. Place the EUT on the table and set it in the transmitting mode.
2. Remove the antenna from the EUT and then connect a low loss RF cable from the antenna port to the Power sensor.

*The results shown in this test report refer only to the sample(s) tested unless otherwise stated. This test report cannot be reproduced, except in full, without prior written permission of the Company.*

## 5.4. Test Results

Ambient temperature : (23 ± 2) °C

Relative humidity : 47 % R.H.

Power source: Inner battery

Operation Mode	Channel	Channel Frequency (MHz)	Attenuator + Cable offset (dB)	Peak Power Result (dB m)	Peak Power Limit (dB m)
GFSK	Low	2 402	16.31	0.70	30.00
	Middle	2 441	16.31	0.78	30.00
	High	2 480	16.31	0.17	30.00
8DPSK	Low	2 402	16.31	3.00	20.97
	Middle	2 441	16.31	2.63	20.97
	High	2 480	16.31	1.83	20.97

Power source: Micro USB

Operation Mode	Channel	Channel Frequency (MHz)	Attenuator + Cable offset (dB)	Peak Power Result (dB m)	Peak Power Limit (dB m)
GFSK	Low	2 402	16.31	0.72	30.00
	Middle	2 441	16.31	0.75	30.00
	High	2 480	16.31	0.18	30.00
8DPSK	Low	2 402	16.31	3.04	20.97
	Middle	2 441	16.31	2.65	20.97
	High	2 480	16.31	1.86	20.97

The results shown in this test report refer only to the sample(s) tested unless otherwise stated. This test report cannot be reproduced, except in full, without prior written permission of the Company.

## 6. Hopping Channel Separation

### 6.1. Test Setup

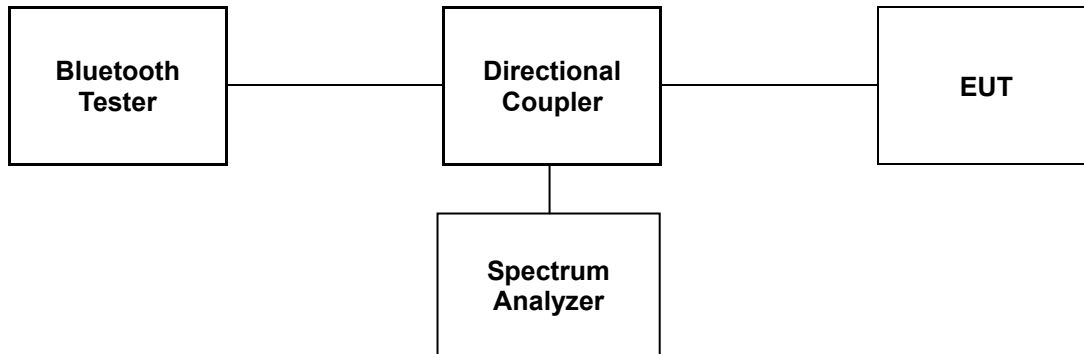

### 6.2. Limit

§15.247(a)(1) Frequency hopping system operating in 2 400 – 2 483.5 MHz. Band may have hopping channel carrier frequencies that are separated by 25 kHz or two-third of 20 dB bandwidth of the hopping channel, whichever is greater, provided the systems operate with an output power no greater than 125 mW.

### 6.3. Test Procedure

1. Check the calibration of the measuring instrument using either an internal calibrator or a known signal from an external generator.
2. Position the EUT as shown in test setup without connection to measurement instrument. Turn on the EUT and connect it to measurement instrument. Then set it to any one convenient frequency within its operating range.
3. By using the MaxHold function record the separation of adjacent channels.
4. Measure the frequency difference of these two adjacent channels by spectrum analyzer MARK function. And then plot the result on spectrum analyzer screen.
5. Repeat above procedures until all frequencies measured were complete.
6. Set center frequency of spectrum analyzer = middle of hopping channel.
7. Set the spectrum analyzer as RBW = 100 kHz, VBW = 100 kHz, Span = 5 MHz and Sweep = auto.

*The results shown in this test report refer only to the sample(s) tested unless otherwise stated. This test report cannot be reproduced, except in full, without prior written permission of the Company.*

## 6.4. Test Results

Ambient temperature : (23 ± 2) °C  
 Relative humidity : 47 % R.H.

Power source: Inner battery

Operation Mode	Channel (Middle)	Adjacent Hopping Channel Separation (kHz)	Two-third of 20 dB Bandwidth (kHz)	Minimum Bandwidth (kHz)
GFSK	2 441 MHz	1 000	526	25
8DPSK	2 441 MHz	1 000	807	25

Power source: Micro USB

Operation Mode	Channel (Middle)	Adjacent Hopping Channel Separation (kHz)	Two-third of 20 dB Bandwidth (kHz)	Minimum Bandwidth (kHz)
GFSK	2 441 MHz	1 000	520	25
8DPSK	2 441 MHz	1 000	807	25

Note ;

20 dB bandwidth measurement, the measured channel separation should be greater than two-third of 20 dB bandwidth or Minimum bandwidth.

*The results shown in this test report refer only to the sample(s) tested unless otherwise stated. This test report cannot be reproduced, except in full, without prior written permission of the Company.*

**Operating Mode: GFSK (Inner battery)**

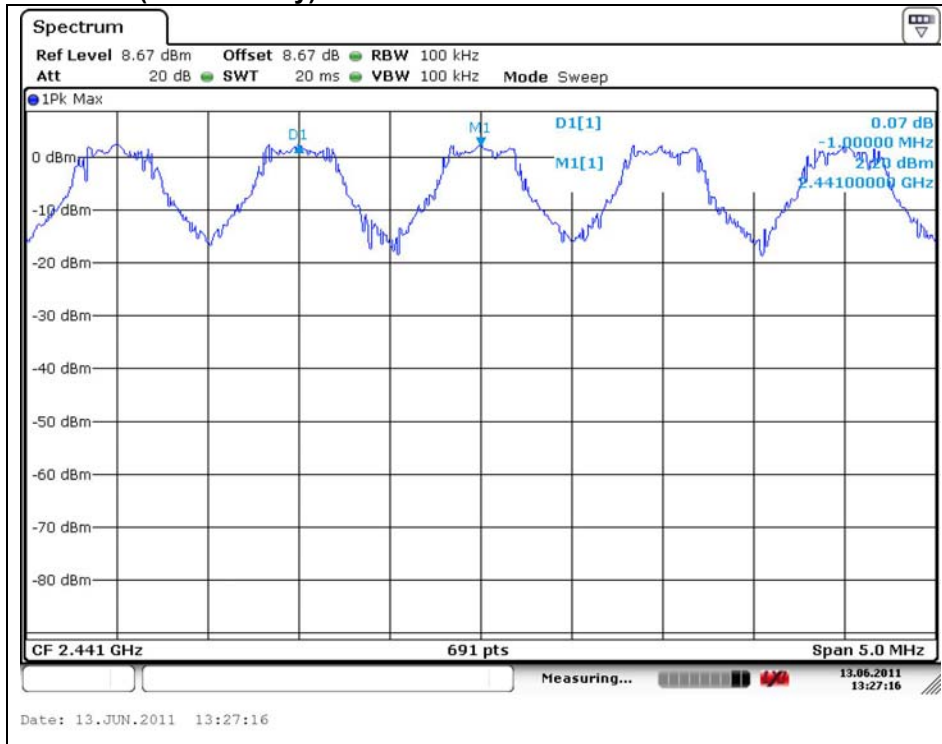

**Operating Mode: 8DPSK (Inner battery)**

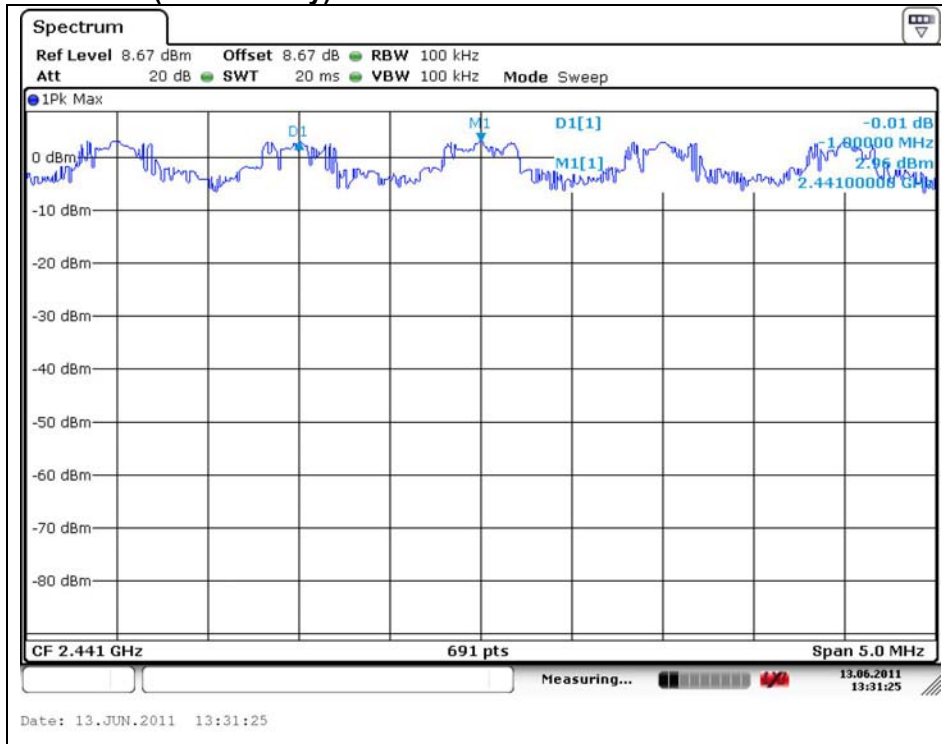

The results shown in this test report refer only to the sample(s) tested unless otherwise stated. This test report cannot be reproduced, except in full, without prior written permission of the Company.

**Operating Mode: GFSK (Micro USB)**

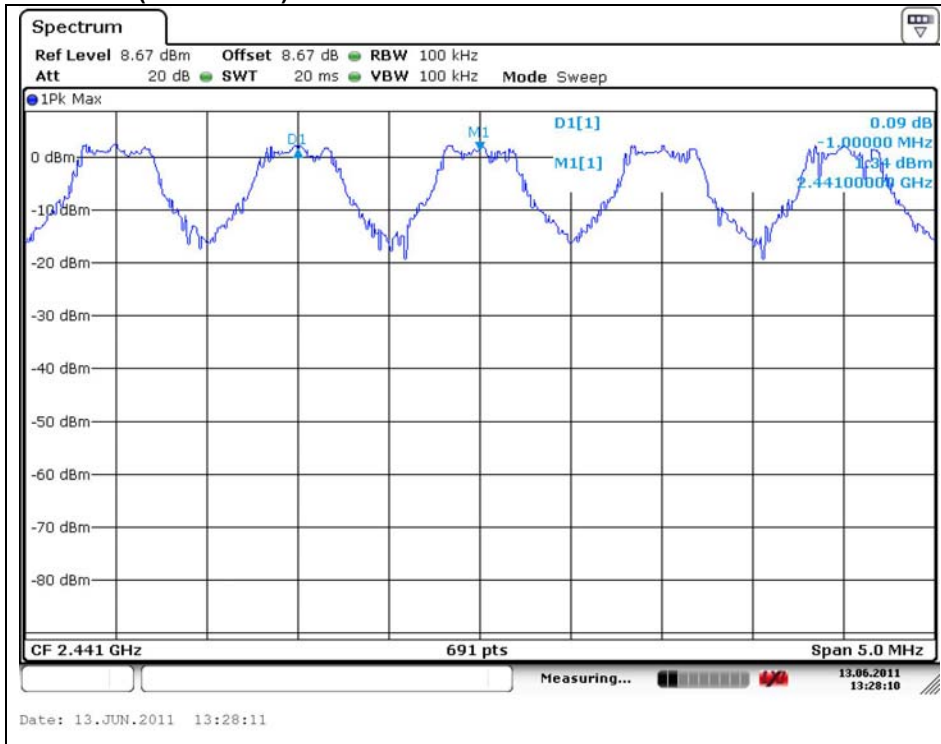

**Operating Mode: 8DPSK (Micro USB)**

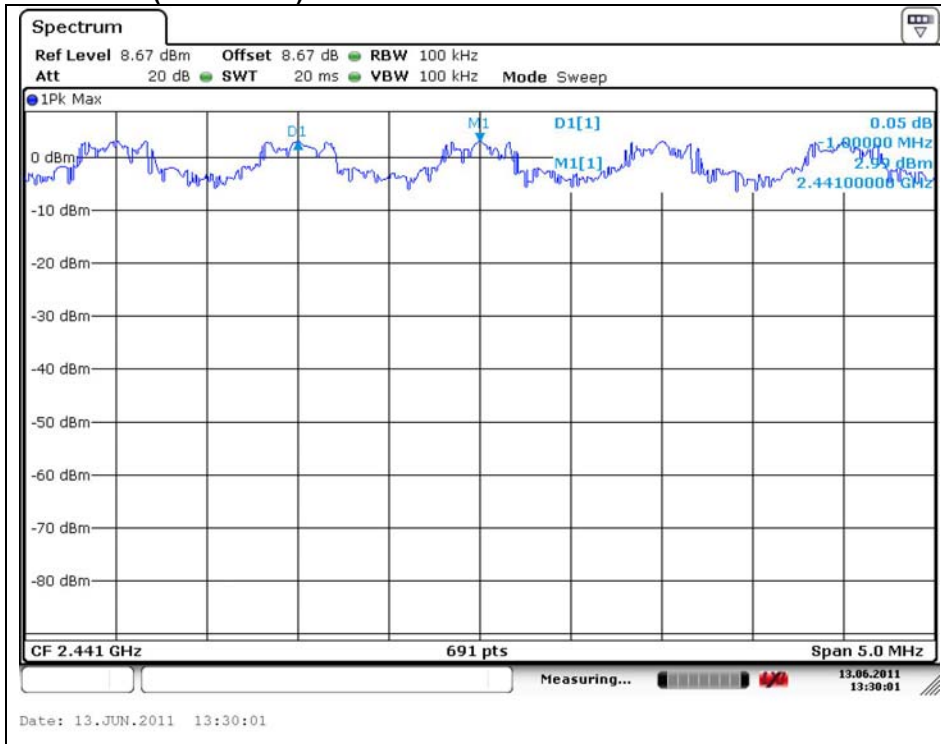

The results shown in this test report refer only to the sample(s) tested unless otherwise stated. This test report cannot be reproduced, except in full, without prior written permission of the Company.

## 7. Number of Hopping Frequency

### 7.1. Test Setup

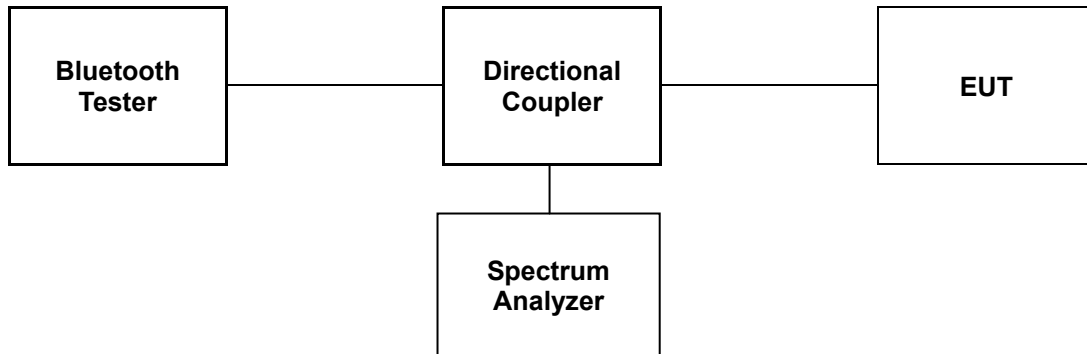

### 7.2. Limit

§15.247(b)(1), For frequency hopping systems operating in the 2 400 – 2 483.5 MHz employing at least 75 non-overlapping hopping channels, and all frequency hopping systems in the 5 725 – 5 805 MHz band: 1 Watt.

### 7.3. Test Procedure

1. Place the EUT on the table and set it in transmitting mode.
2. Remove the antenna from the EUT and then connect a low loss RF cable from the antenna the port to the Spectrum analyzer
3. Set spectrum analyzer Start = 2 400 MHz, Stop = 2 441.5 MHz, Sweep=auto and Start = 2 441.5 MHz, Stop = 2 483.5 MHz, Sweep = auto.
4. Set the spectrum analyzer as RBW, VBW = 100 kHz.
5. Max hold, view and count how many channel in the band.

*The results shown in this test report refer only to the sample(s) tested unless otherwise stated. This test report cannot be reproduced, except in full, without prior written permission of the Company.*

### 7.4. Test Results

Ambient temperature : (23 ± 2) °C  
 Relative humidity : 47 % R.H.

Power source: Inner battery

Operation Mode	Number of Hopping Frequency	Limit
GFSK	79	≥ 75
8DPSK	79	≥ 75

Power source: Micro USB

Operation Mode	Number of Hopping Frequency	Limit
GFSK	79	≥ 75
8DPSK	79	≥ 75

*The results shown in this test report refer only to the sample(s) tested unless otherwise stated. This test report cannot be reproduced, except in full, without prior written permission of the Company.*

**Operating Mode: GFSK (Inner battery)**

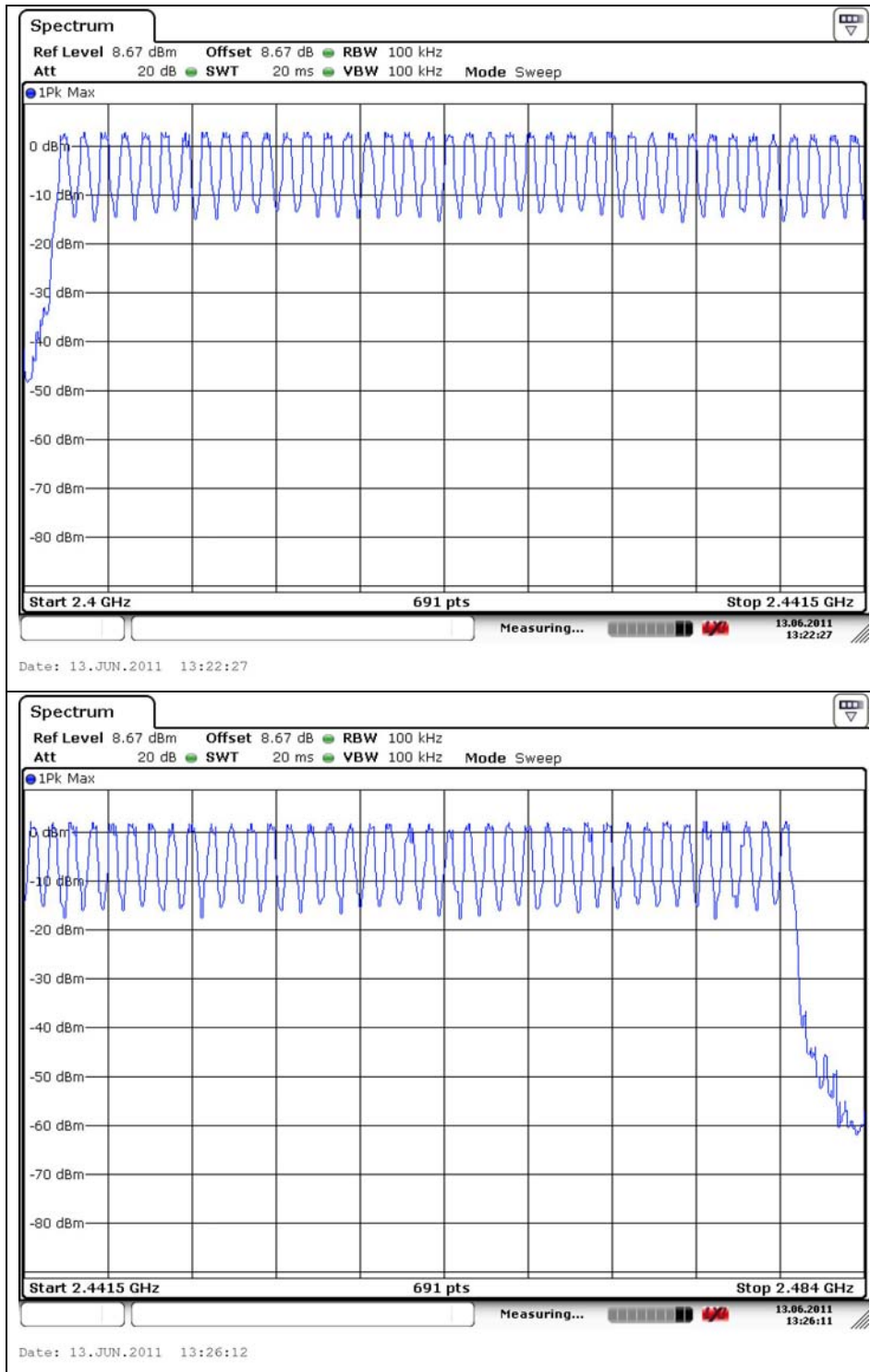

The results shown in this test report refer only to the sample(s) tested unless otherwise stated. This test report cannot be reproduced, except in full, without prior written permission of the Company.

**Operating Mode: 8DPSK (Inner battery)**

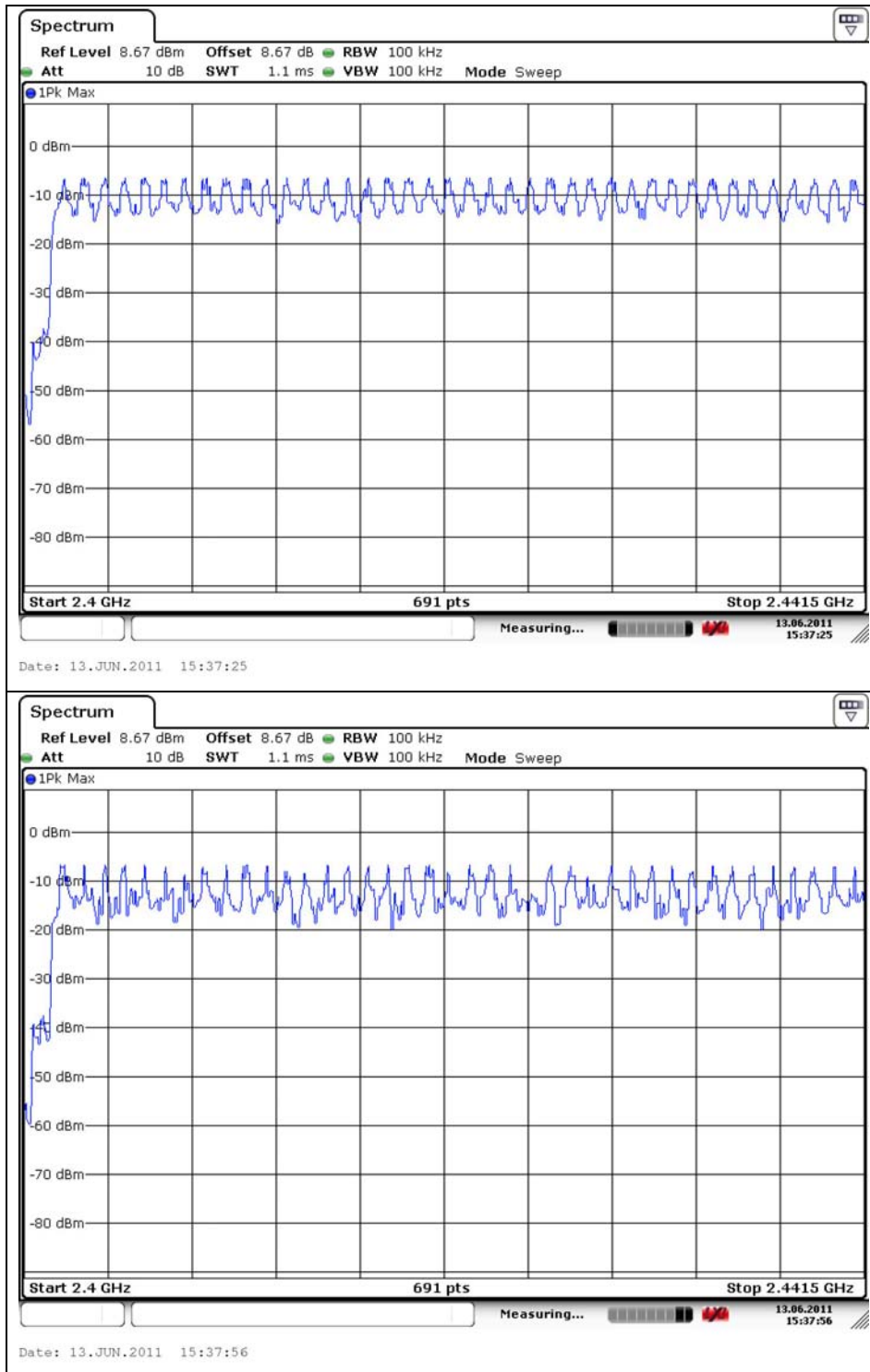

The results shown in this test report refer only to the sample(s) tested unless otherwise stated. This test report cannot be reproduced, except in full, without prior written permission of the Company.

**Operating Mode: GFSK (Micro USB)**

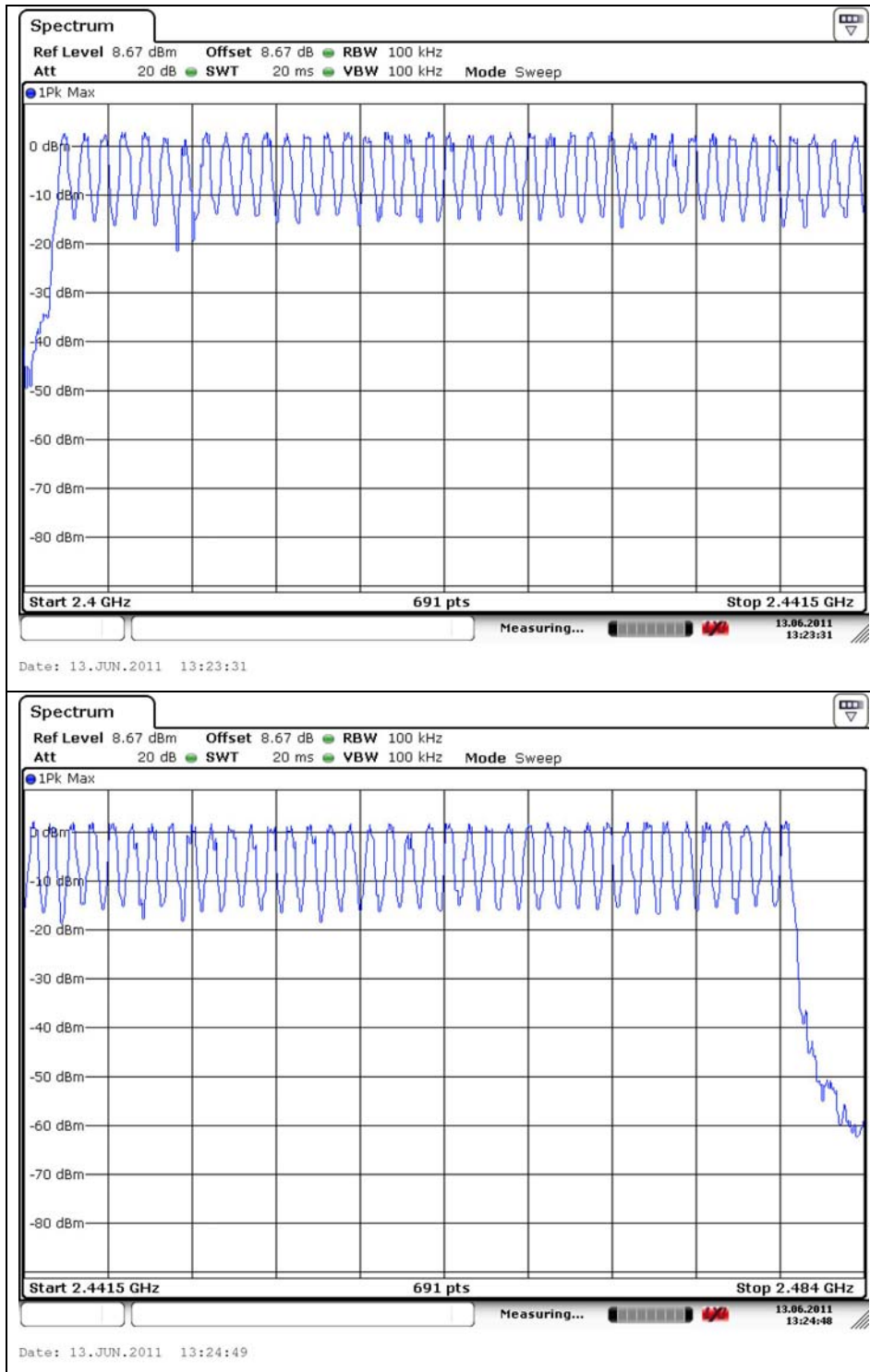

The results shown in this test report refer only to the sample(s) tested unless otherwise stated. This test report cannot be reproduced, except in full, without prior written permission of the Company.

**Operating Mode: 8DPSK (Micro USB)**

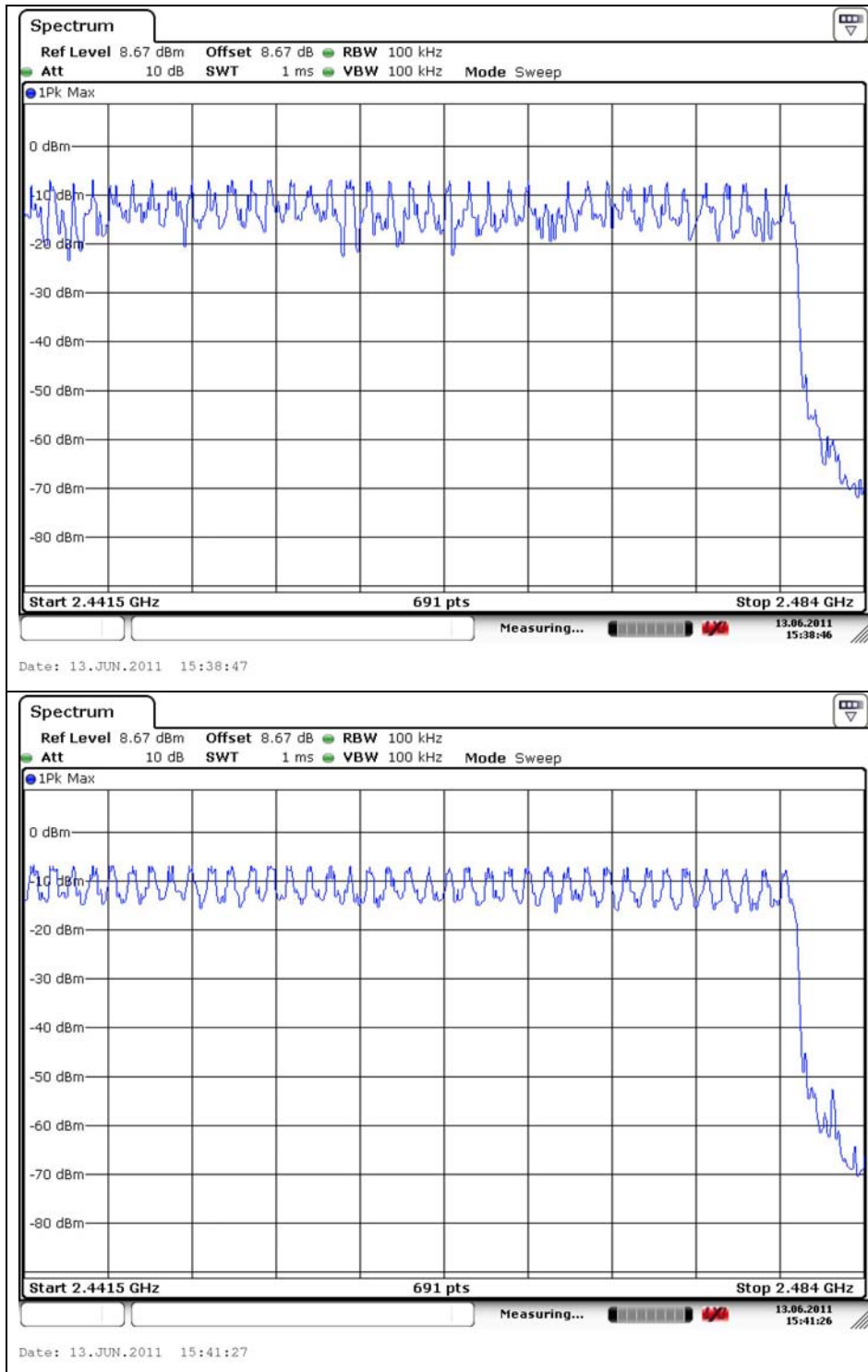

The results shown in this test report refer only to the sample(s) tested unless otherwise stated. This test report cannot be reproduced, except in full, without prior written permission of the Company.

## 8. Time of Occupancy (Dwell Time)

### 8.1. Test Set up

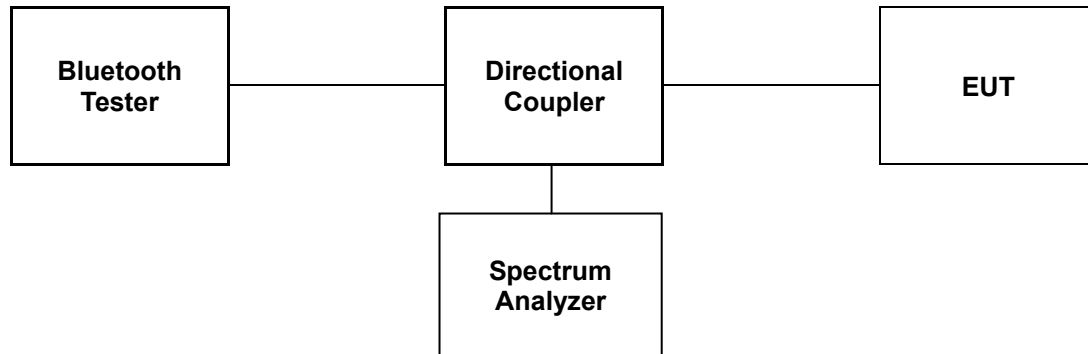

### 8.2. Limit

§15.247(a)(1)(iii) For frequency hopping system operating in the 2 400 – 2 483.5 MHz band, the average time of occupancy on any frequency shall not be greater than 0.4 second within a 31.6 second period.

A period time = 0.4(s) \* 79 = 31.6(s)

### 8.3. Test Procedure

1. Check the calibration of the measuring instrument using either an internal calibrator or a known signal from an external generator.
2. Position the EUT as shown in test setup without connection to measurement instrument. Turn on the EUT and connect its antenna terminal to measurement instrument via a low loss cable.
3. Adjust the center frequency of spectrum analyzer on any frequency be measured and set spectrum analyzer to zero span mode. And then, set RBW and VBW of spectrum analyzer to proper value.
4. Measure the time duration of one transmission on the measured frequency. And then plot the result with time difference of this time duration.
5. Repeat above procedures until all frequencies measured were complete.
6. The Bluetooth has 3 type of payload, DH1, DH3, DH5 and 3-DH1, 3-DH3, 3-DH5. The hopping rate is 1 600 per second.

*The results shown in this test report refer only to the sample(s) tested unless otherwise stated. This test report cannot be reproduced, except in full, without prior written permission of the Company.*

## 8.4. Test Results

Ambient temperature : (23 ± 2) °C

Relative humidity : 47 % R.H.

Time of occupancy on the TX channel in 31.6sec  
 = time domain slot length × (hop rate ÷ number of hop per channel) × 31.6

### 8.4.1. Packet Type: DH1, 3-DH1 (Inner Battery)

Operation Mode	Frequency	Dwell Time (ms)	Time of occupancy on the Tx Channel in 31.6 sec (ms)	Limit for time of occupancy on the Tx Channel in 31.6 sec (ms)
GFSK	2 441 MHz	0.442	141.44	400
8DPSK	2 441 MHz	0.442	141.44	400

2 441 MHz : 0.442 (ms) × [(1 600 ÷ 2) ÷ 79] × 31.6(s) = 141.44 (ms)

*The results shown in this test report refer only to the sample(s) tested unless otherwise stated. This test report cannot be reproduced, except in full, without prior written permission of the Company.*

**Operating Mode: GFSK**

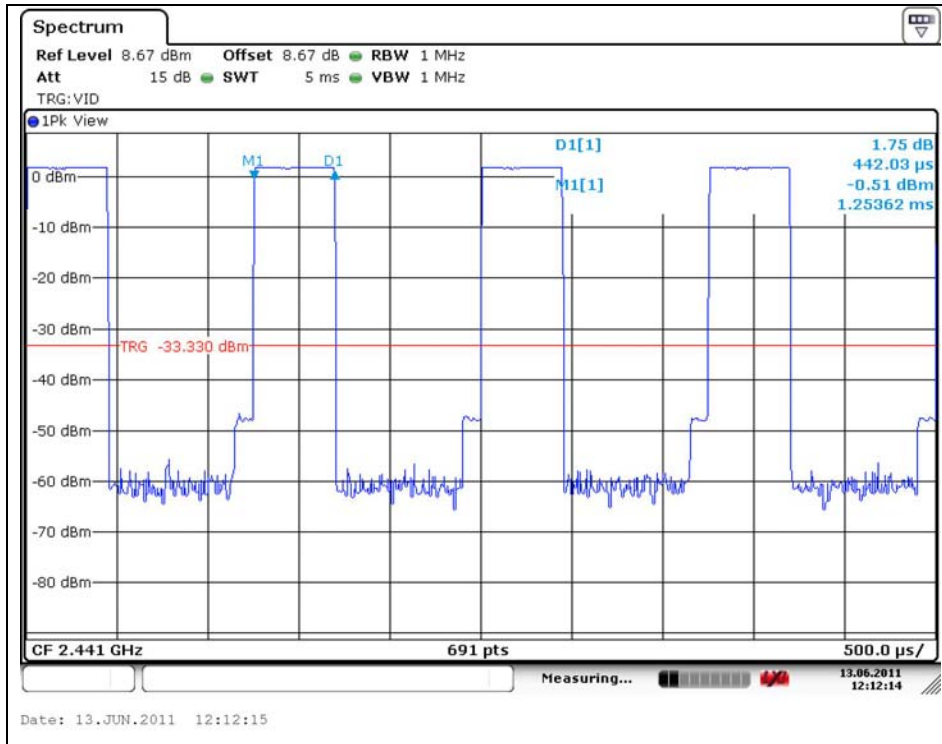

**Operating Mode: 8DPSK**

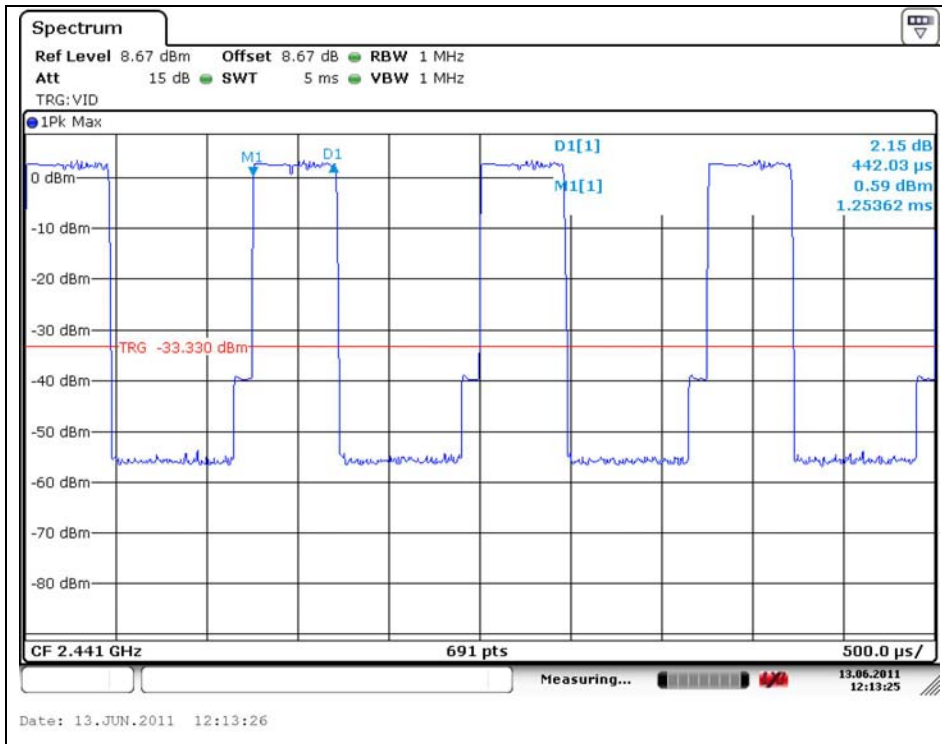

The results shown in this test report refer only to the sample(s) tested unless otherwise stated. This test report cannot be reproduced, except in full, without prior written permission of the Company.

### 8.4.2. Packet Type: DH3, 3-DH3 (Inner Battery)

Operation Mode	Frequency	Dwell Time (ms)	Time of occupancy on the Tx Channel in 31.6 sec (ms)	Limit for time of occupancy on the Tx Channel in 31.6 sec (ms)
GFSK	2 441 MHz	1.703	272.48	400
8DPSK	2 441 MHz	1.717	274.72	400

2 441 MHz :  $1.703 \text{ (ms)} \times [(1\ 600 \div 4) \div 79] \times 31.6\text{(s)} = 272.48 \text{ (ms)}$

2 441 MHz :  $1.717 \text{ (ms)} \times [(1\ 600 \div 4) \div 79] \times 31.6\text{(s)} = 274.72 \text{ (ms)}$

*The results shown in this test report refer only to the sample(s) tested unless otherwise stated. This test report cannot be reproduced, except in full, without prior written permission of the Company.*

**Operating Mode: GFSK**

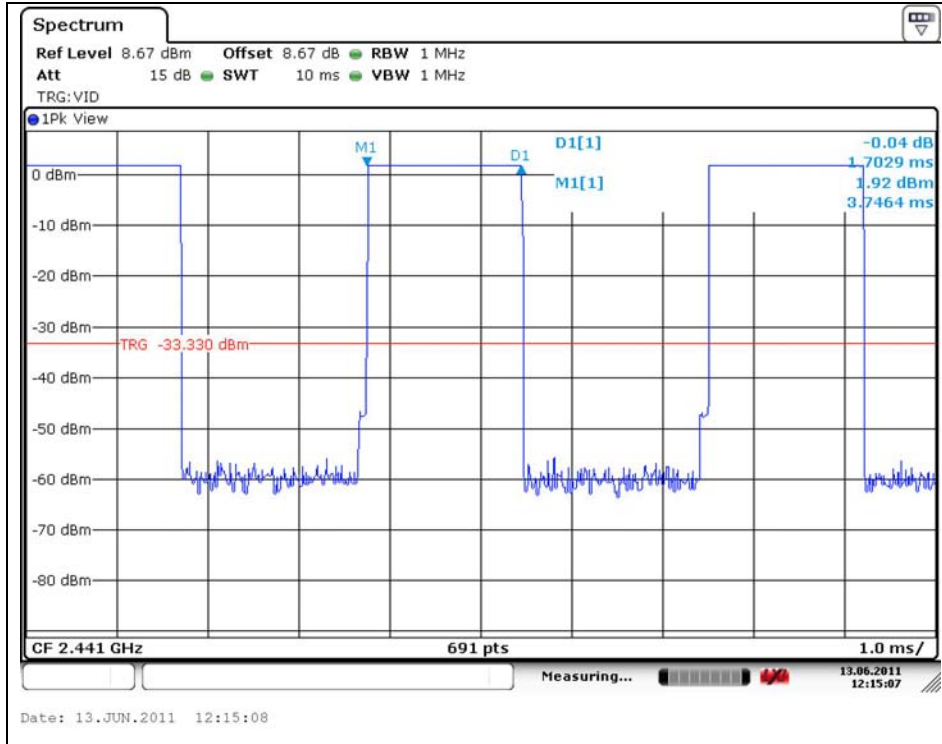

**Operating Mode: 8DPSK**

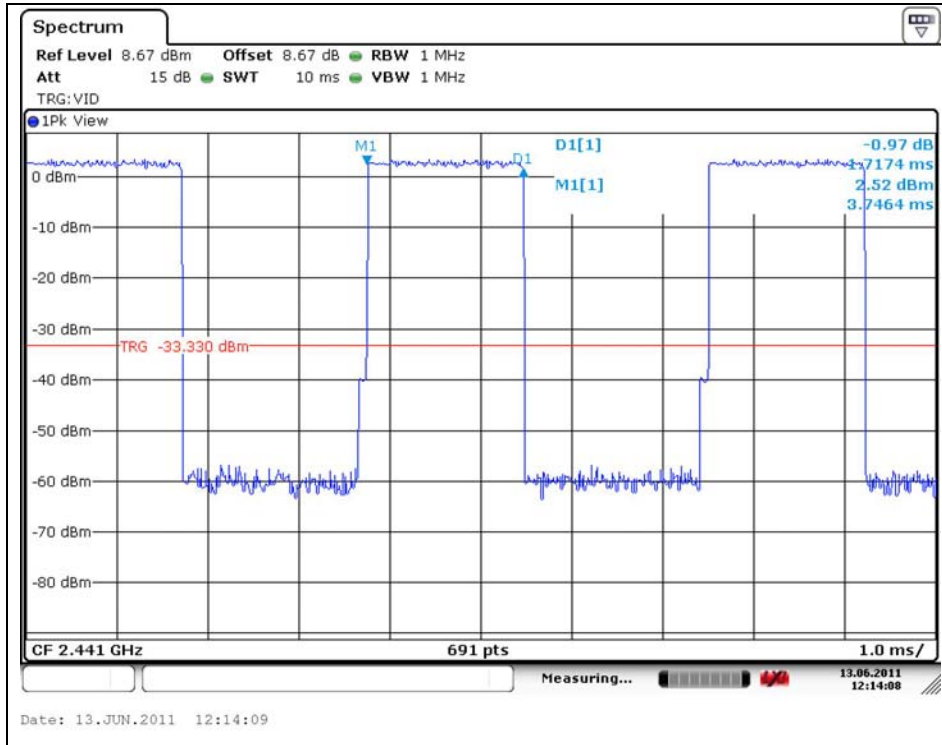

The results shown in this test report refer only to the sample(s) tested unless otherwise stated. This test report cannot be reproduced, except in full, without prior written permission of the Company.

### 8.4.3. Packet Type: DH5, 3-DH5 (Inner Battery)

Operation Mode	Frequency	Dwell Time (ms)	Time of occupancy on the Tx Channel in 31.6 sec (ms)	Limit for time of occupancy on the Tx Channel in 31.6 sec (ms)
GFSK	2 441 MHz	2.92	311.47	400
8DPSK	2 441 MHz	2.92	311.47	400

$$2\,441\text{ MHz} : 2.92\text{ (ms)} \times [(1\,600 \div 6) \div 79] \times 31.6\text{(s)} = 311.47\text{ (ms)}$$

*The results shown in this test report refer only to the sample(s) tested unless otherwise stated. This test report cannot be reproduced, except in full, without prior written permission of the Company.*

**Operating Mode: GFSK**

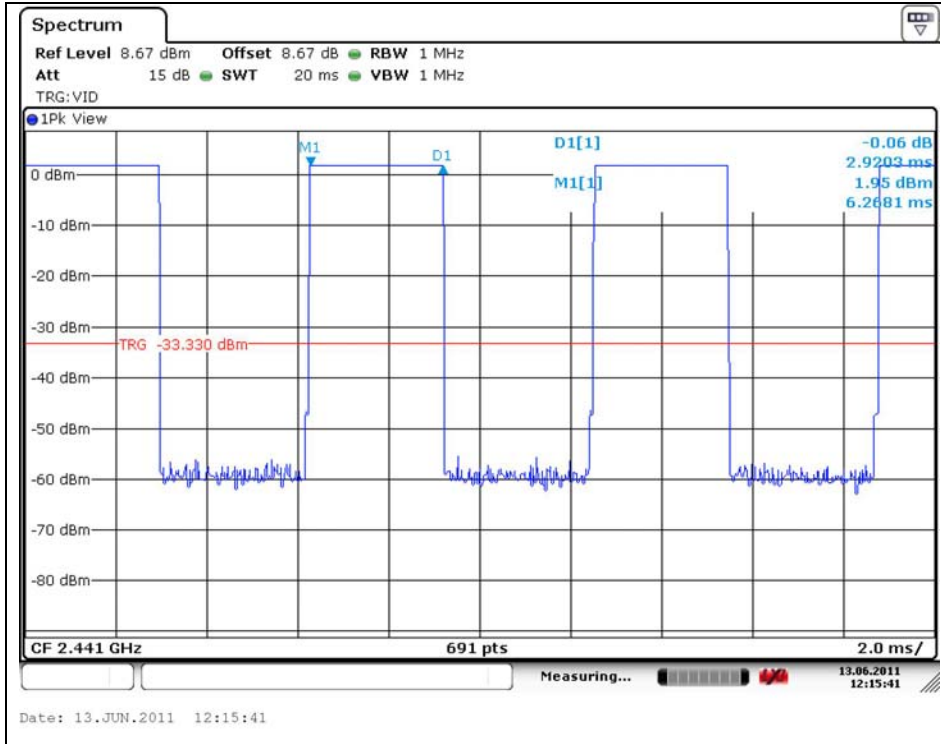

**Operating Mode: 8DPSK**

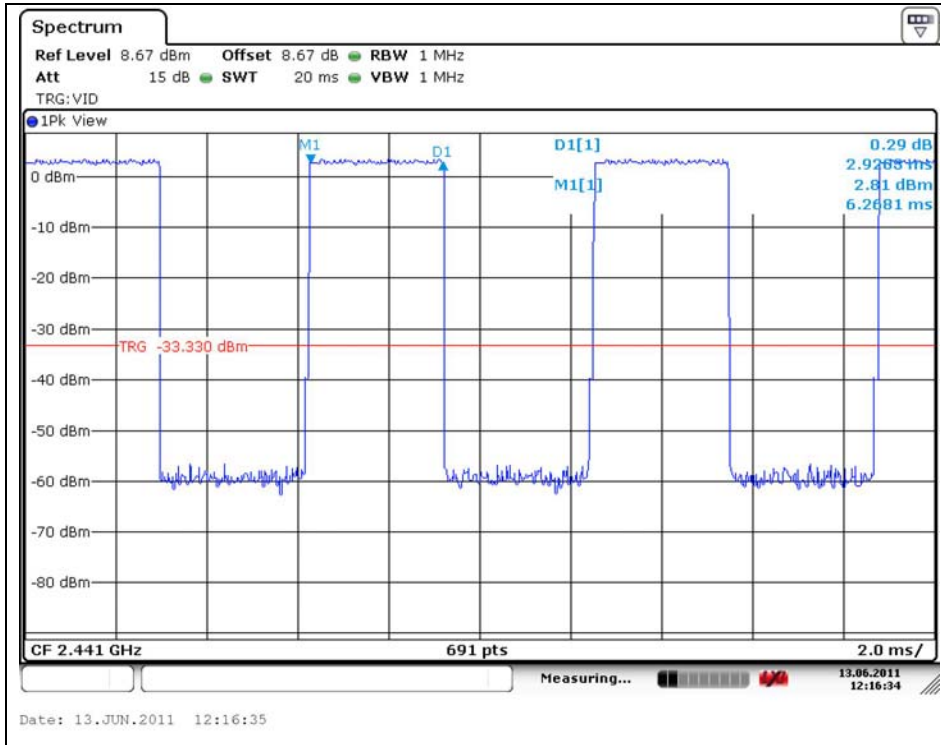

The results shown in this test report refer only to the sample(s) tested unless otherwise stated. This test report cannot be reproduced, except in full, without prior written permission of the Company.

#### 8.4.4. Packet Type: DH1, 3-DH1 (Micro USB)

Operation Mode	Frequency	Dwell Time (ms)	Time of occupancy on the Tx Channel in 31.6 sec (ms)	Limit for time of occupancy on the Tx Channel in 31.6 sec (ms)
GFSK	2 441 MHz	0.442	141.44	400
8DPSK	2 441 MHz	0.442	141.44	400

2 441 MHz :  $0.442 \text{ (ms)} \times [(1\ 600 \div 2) \div 79] \times 31.6 \text{ (s)} = 141.44 \text{ (ms)}$

2 441 MHz :  $0.442 \text{ (ms)} \times [(1\ 600 \div 2) \div 79] \times 31.6 \text{ (s)} = 141.44 \text{ (ms)}$

*The results shown in this test report refer only to the sample(s) tested unless otherwise stated. This test report cannot be reproduced, except in full, without prior written permission of the Company.*

**Operating Mode: GFSK**

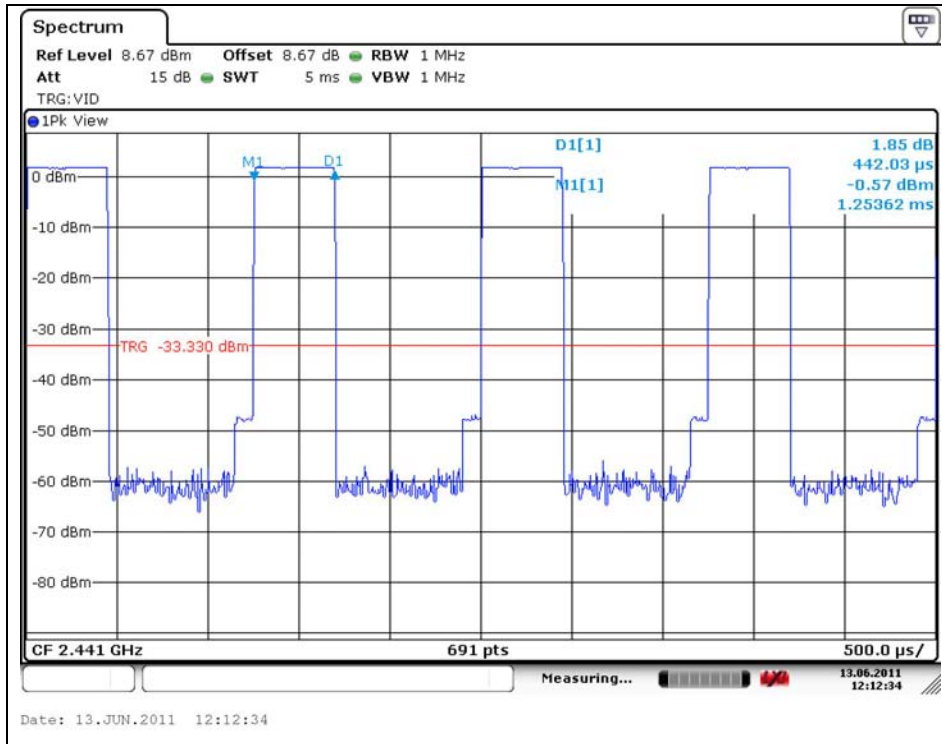

**Operating Mode: 8DPSK**

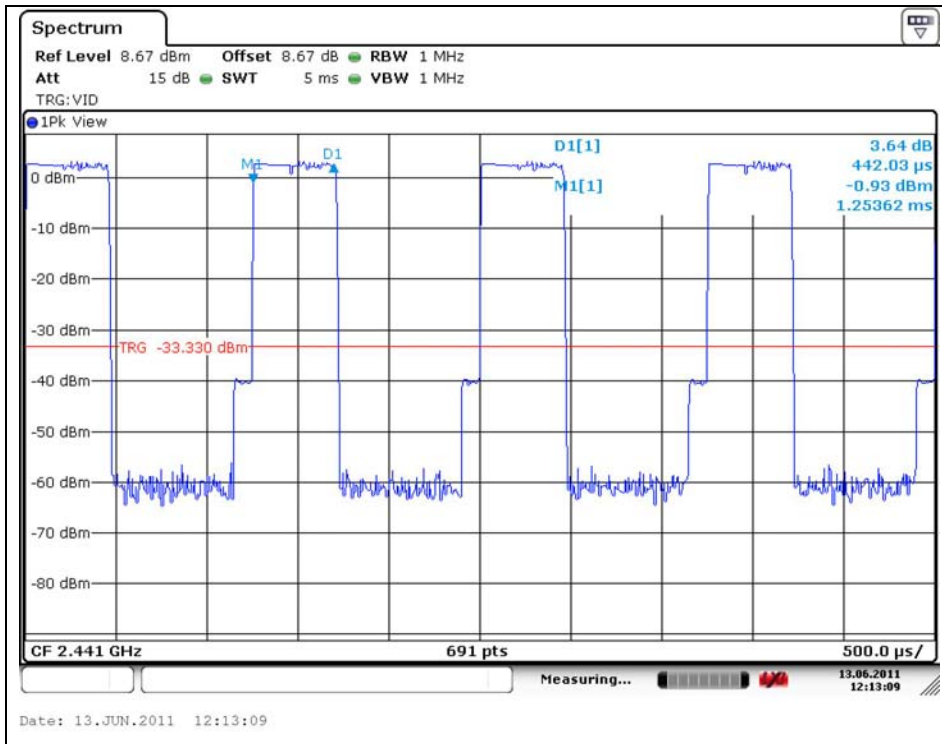

The results shown in this test report refer only to the sample(s) tested unless otherwise stated. This test report cannot be reproduced, except in full, without prior written permission of the Company.

#### 8.4.5. Packet Type: DH3, 3-DH3 (Micro USB)

Operation Mode	Frequency	Dwell Time (ms)	Time of occupancy on the Tx Channel in 31.6 sec (ms)	Limit for time of occupancy on the Tx Channel in 31.6 sec (ms)
GFSK	2 441 MHz	1.703	272.48	400
8DPSK	2 441 MHz	1.717	274.72	400

2 441 MHz :  $1.703 \text{ (ms)} \times [(1\ 600 \div 4) \div 79] \times 31.6\text{(s)} = 272.48 \text{ (ms)}$

2 441 MHz :  $1.717 \text{ (ms)} \times [(1\ 600 \div 4) \div 79] \times 31.6\text{(s)} = 274.72 \text{ (ms)}$

*The results shown in this test report refer only to the sample(s) tested unless otherwise stated. This test report cannot be reproduced, except in full, without prior written permission of the Company.*

### Operating Mode: GFSK

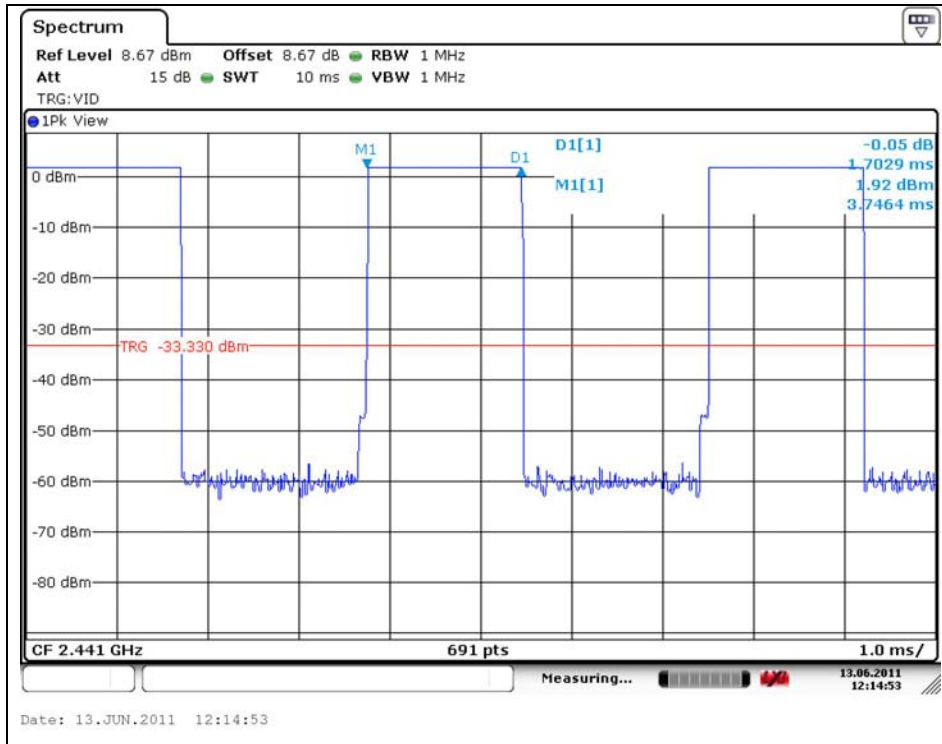

### Operating Mode: 8DPSK

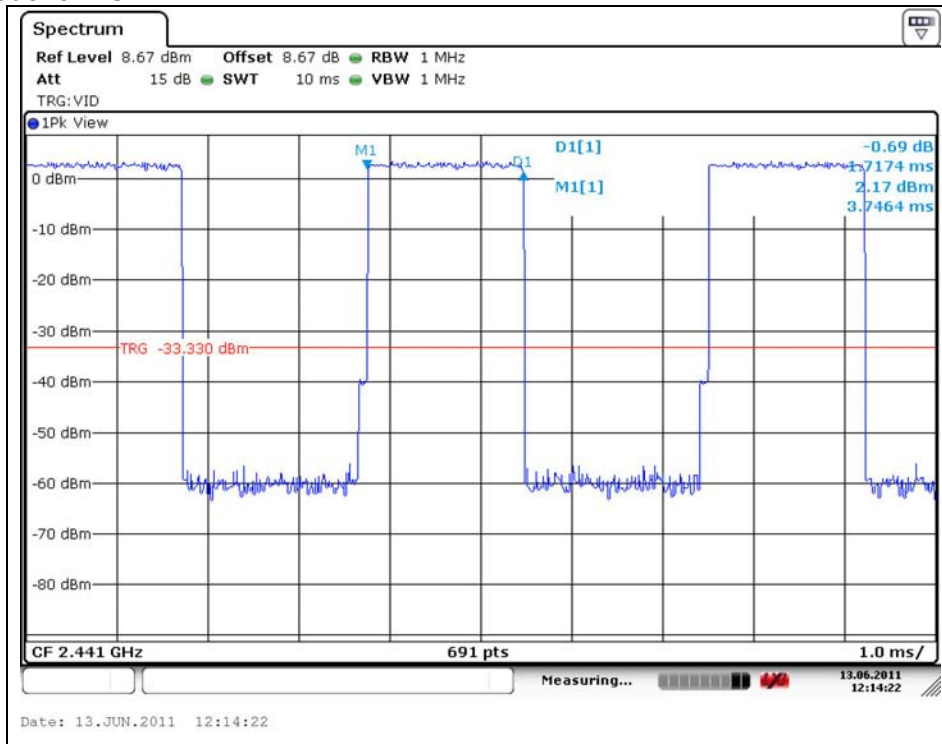

The results shown in this test report refer only to the sample(s) tested unless otherwise stated. This test report cannot be reproduced, except in full, without prior written permission of the Company.

#### 8.4.6. Packet Type: DH5, 3-DH5 (Micro USB)

Operation Mode	Frequency	Dwell Time (ms)	Time of occupancy on the Tx Channel in 31.6 sec (ms)	Limit for time of occupancy on the Tx Channel in 31.6 sec (ms)
GFSK	2 441 MHz	2.920	311.47	400
8DPSK	2 441 MHz	2.920	311.47	400

$$2\,441\text{ MHz} : 2.92\text{ (ms)} \times [(1\,600 \div 6) \div 79] \times 31.6\text{(s)} = 311.47\text{ (ms)}$$

*The results shown in this test report refer only to the sample(s) tested unless otherwise stated. This test report cannot be reproduced, except in full, without prior written permission of the Company.*

### Operating Mode: GFSK

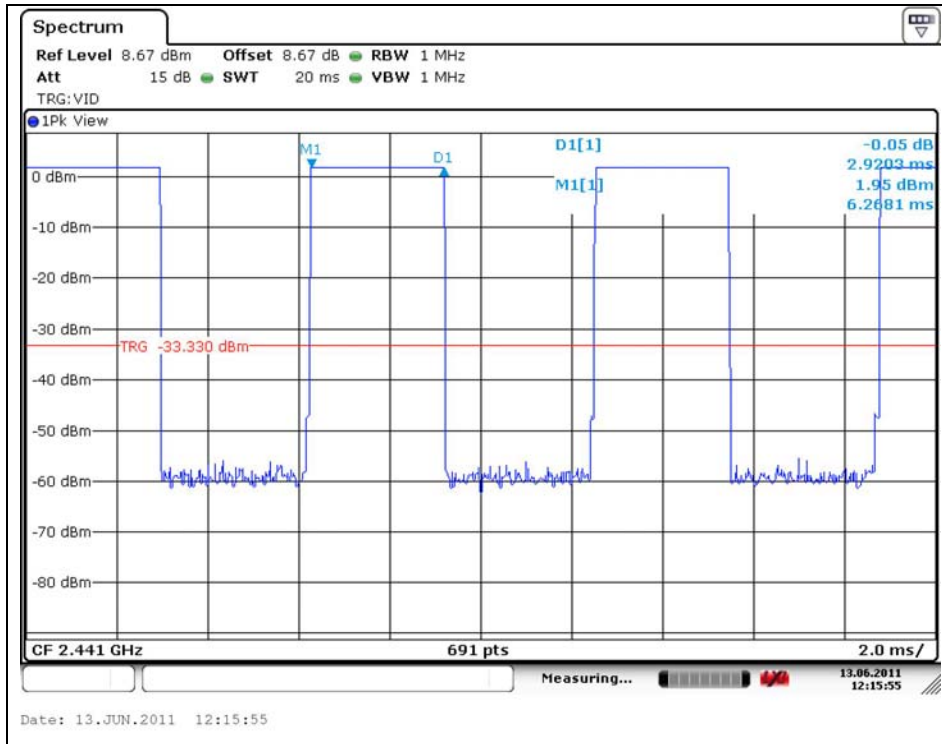

### Operating Mode: 8DPSK

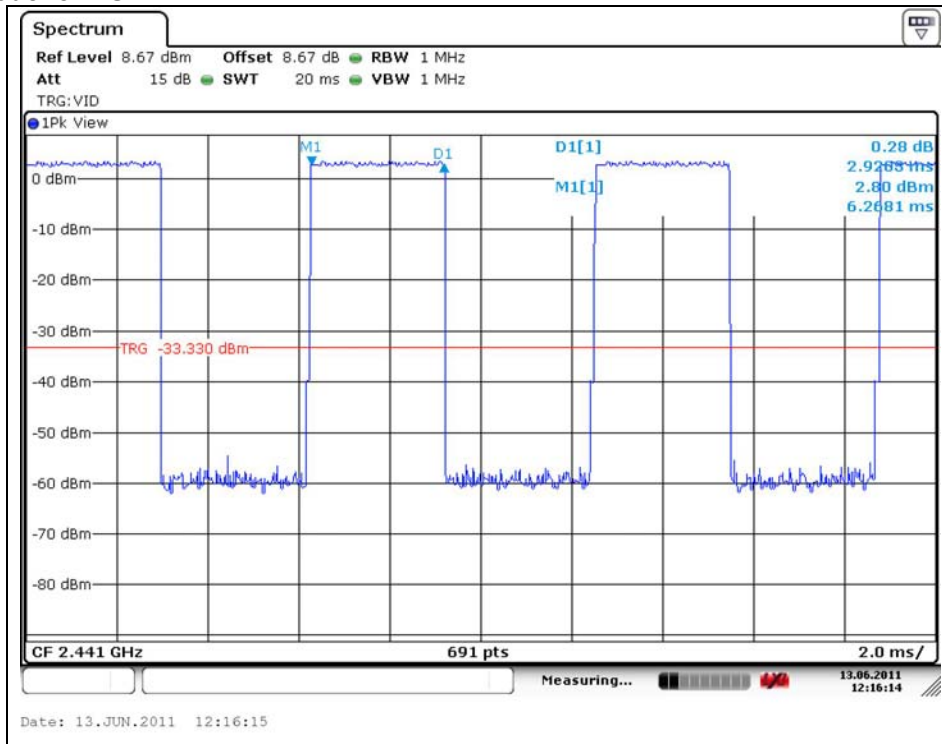

The results shown in this test report refer only to the sample(s) tested unless otherwise stated. This test report cannot be reproduced, except in full, without prior written permission of the Company.

## 9. Transmitter AC Power Line Conducted Emission

### 9.1. Test Setup

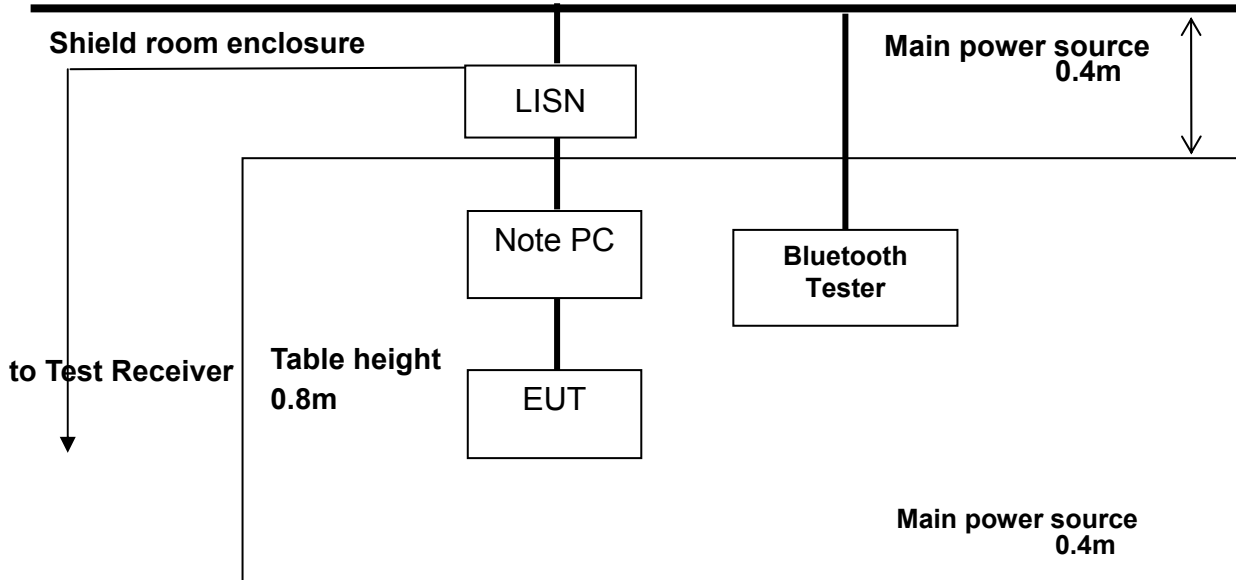

### 9.2. Limit

According to §15.207(a) for an intentional radiator that is designed to be connected to the public utility (AC) power line, the radio frequency voltage that is conducted back onto the AC power line on any frequency or frequencies, within the band 150 kHz to 30 MHz, shall not exceed the limits in the following table, as measured using a 50 uH/50 ohm line impedance stabilization network(LISN).

Compliance with the provision of this paragraph shall on the measurement of the radio frequency voltage between each power line and ground at the power terminal. The lower applies at the boundary between the frequency ranges.

Frequency of Emission (MHz)	Conducted limit (dB $\mu$ V)	
	Quasi-peak	Average
0.15 – 0.50	66 - 56*	56 - 46*
0.50 – 5.00	56	46
5.00 – 30.0	60	50

\* Decreases with the logarithm of the frequency.

The results shown in this test report refer only to the sample(s) tested unless otherwise stated. This test report cannot be reproduced, except in full, without prior written permission of the Company.

---

### 9.3. Test Procedures

Radiated emissions from the EUT were measured according to the dictates of ANSI C63.4:2003

1. The test procedure is performed in a 6.5m × 3.6m × 3.6m (L × W × H) shielded room. The EUT along with its peripherals were placed on a 1.0 m(W) × 1.5 m(L) and 0.8 m in height wooden table and the EUT was adjusted to maintain a 0.4 meter space from a vertical reference plane.
2. The EUT was connected to power mains through a line impedance stabilization network (LISN) which provides 50 ohm coupling impedance for measuring instrument and the chassis ground was bounded to the horizontal ground plane of shielded room.
3. All peripherals were connected to the second LISN and the chassis ground also bounded to the horizontal ground plane of shielded room.
4. The excess power cable between the EUT and the LISN was bundled. The power cables of peripherals were unbundled. All connecting cables of EUT and peripherals were moved to find the maximum emission.

---

*The results shown in this test report refer only to the sample(s) tested unless otherwise stated. This test report cannot be reproduced, except in full, without prior written permission of the Company.*

#### 9.4. Test Results (Worst case configuration\_8DPSK )

The following table shows the highest levels of conducted emissions on both phase of Hot and Neutral line.

Ambient temperature : (23 ± 2) °C  
 Relative humidity : 47 % R.H.

Frequency range : 0.15 MHz – 30 MHz

Measured Bandwidth : 9 kHz

FREQ. (MHz)	LEVEL(dB $\mu$ V)		LINE	LIMIT(dB $\mu$ V)		MARGIN(dB)	
	Q-Peak	Average		Q-Peak	Average	Q-Peak	Average
0.235	31.40	13.30	H	62.27	52.27	30.87	38.97
0.515	26.60	13.60	H	56.00	46.00	29.40	32.40
2.070	26.50	14.40	H	56.00	46.00	29.50	31.60
2.345	23.50	12.30	H	56.00	46.00	32.50	33.70
16.840	32.70	24.20	H	60.00	50.00	27.30	25.80
17.475	33.50	25.10	H	60.00	50.00	26.50	24.90
0.260	34.20	14.70	N	61.43	51.43	27.23	36.73
0.425	33.90	17.50	N	57.35	47.35	23.45	29.85
2.100	28.50	16.10	N	56.00	46.00	27.50	29.90
4.315	23.80	17.70	N	56.00	46.00	32.20	28.30
13.430	26.00	18.30	N	60.00	50.00	34.00	31.70
16.725	32.10	22.40	N	60.00	50.00	27.90	27.60

Note ;

Line ( H ) : Hot

Line ( N ) : Neutral

*The results shown in this test report refer only to the sample(s) tested unless otherwise stated. This test report cannot be reproduced, except in full, without prior written permission of the Company.*

**Plot of Conducted Power line**

Test mode : (Hot)

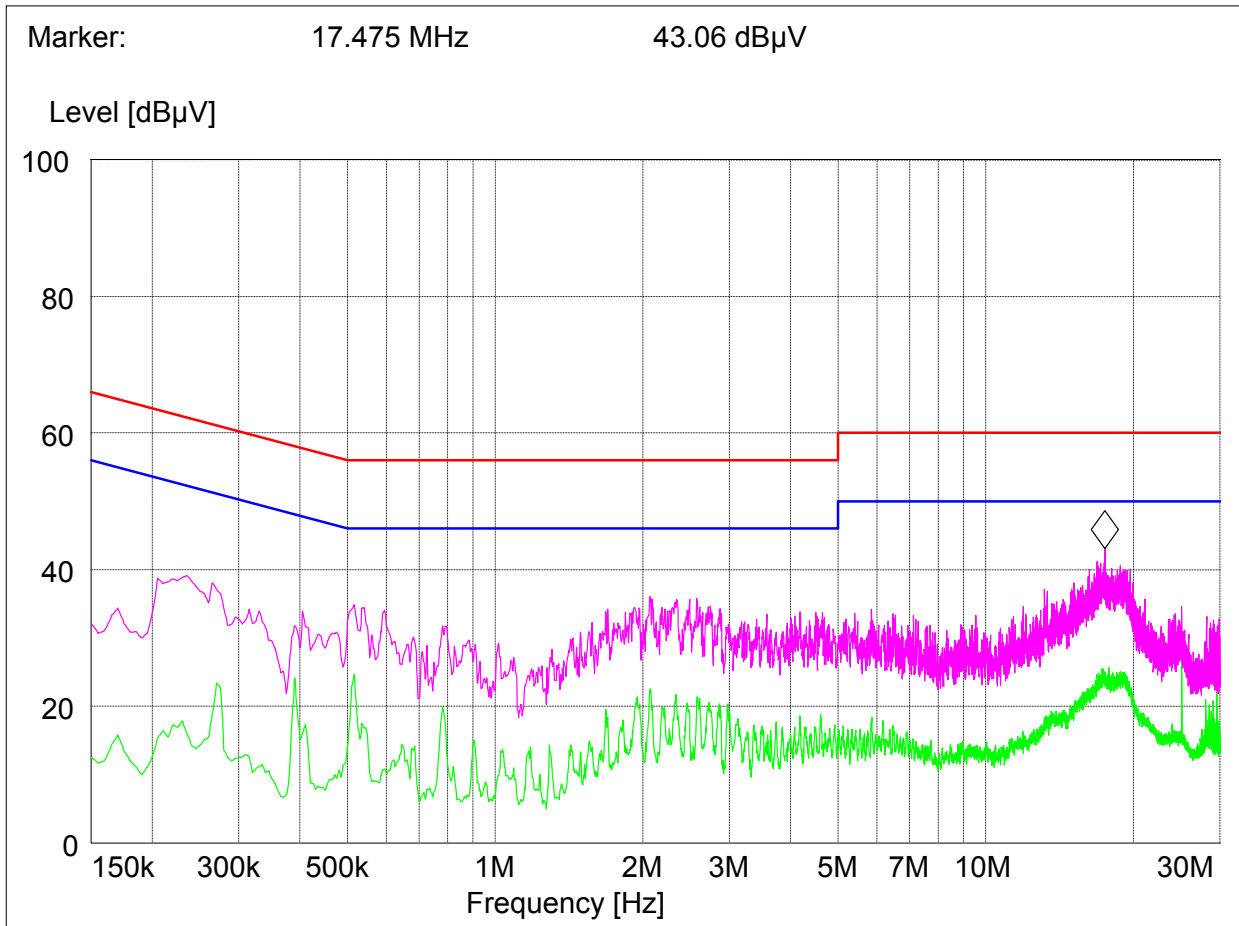

The results shown in this test report refer only to the sample(s) tested unless otherwise stated. This test report cannot be reproduced, except in full, without prior written permission of the Company.

Test mode : (Neutral)

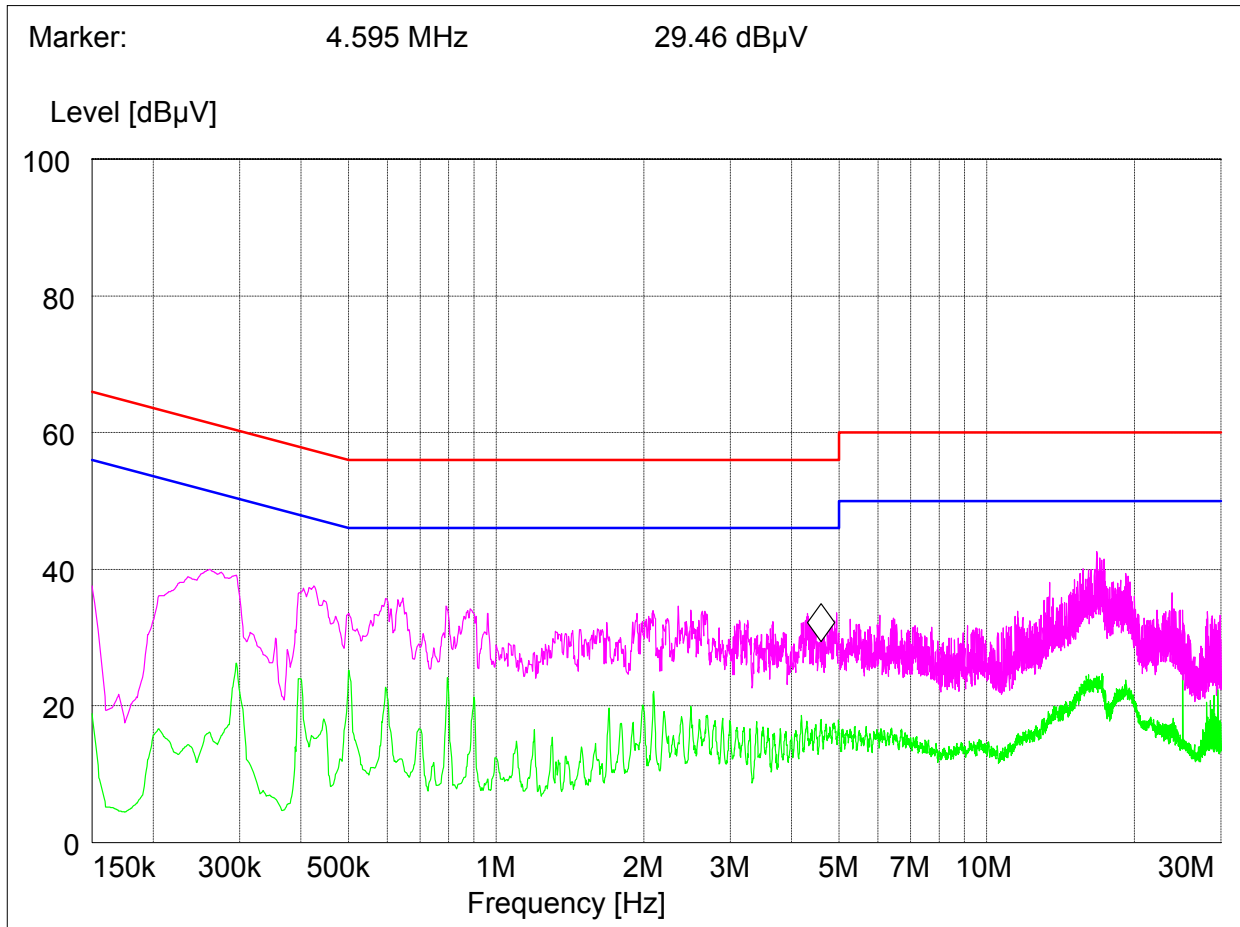

The results shown in this test report refer only to the sample(s) tested unless otherwise stated. This test report cannot be reproduced, except in full, without prior written permission of the Company.

## 10. Receiver AC Power Line Conducted Emission

### 10.1. Test Setup

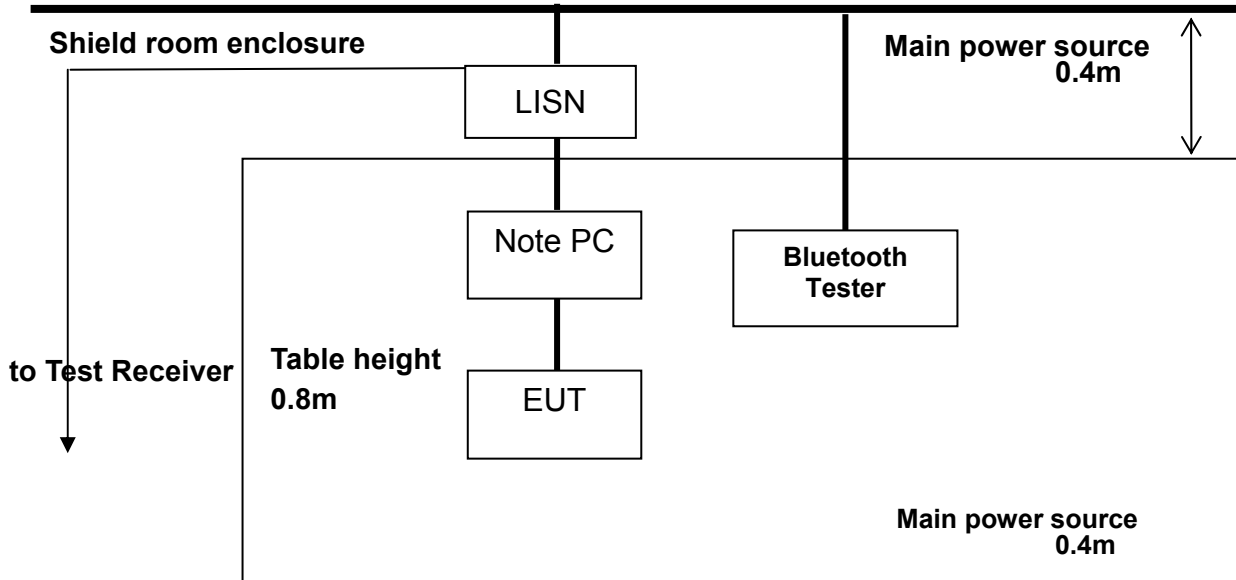

10.2. Limit - Same as clause 9.2.

10.3. Test Procedures- Same as clause 9.3.

*The results shown in this test report refer only to the sample(s) tested unless otherwise stated. This test report cannot be reproduced, except in full, without prior written permission of the Company.*

### 10.4. Test Results

The following table shows the highest levels of conducted emissions on both phase of Hot and Neutral line;

Ambient temperature : (23 ± 2) °C  
 Relative humidity : 47 % R.H.

Frequency range : 0.15 MHz – 30 MHz

Measured Bandwidth : 9 kHz

FREQ. (MHz)	LEVEL(dBuV)		LINE	LIMIT(dBuV)		MARGIN(dB)	
	Q-Peak	Average		Q-Peak	Average	Q-Peak	Average
0.150	38.90	24.20	H	66.00	56.00	27.10	31.80
0.475	22.70	11.40	H	56.43	46.43	33.73	35.03
1.895	24.60	16.10	H	56.00	46.00	31.40	29.90
2.265	25.00	16.10	H	56.00	46.00	31.00	29.90
6.770	24.20	17.20	H	60.00	50.00	35.80	32.80
18.025	35.40	25.30	H	60.00	50.00	24.60	24.70
0.220	33.80	14.10	N	62.82	52.82	29.02	38.72
0.250	35.00	14.00	N	61.76	51.76	26.76	37.76
0.390	28.80	17.10	N	58.06	48.06	29.26	30.96
2.575	26.40	16.40	N	56.00	46.00	29.60	29.60
16.330	31.70	24.10	N	60.00	50.00	28.30	25.90
16.895	31.90	24.50	N	60.00	50.00	28.10	25.50

Note ;

Line ( H ) : Hot

Line ( N ) : Neutral

*The results shown in this test report refer only to the sample(s) tested unless otherwise stated. This test report cannot be reproduced, except in full, without prior written permission of the Company.*

## Plot of Conducted Power line

Test mode : (Hot)

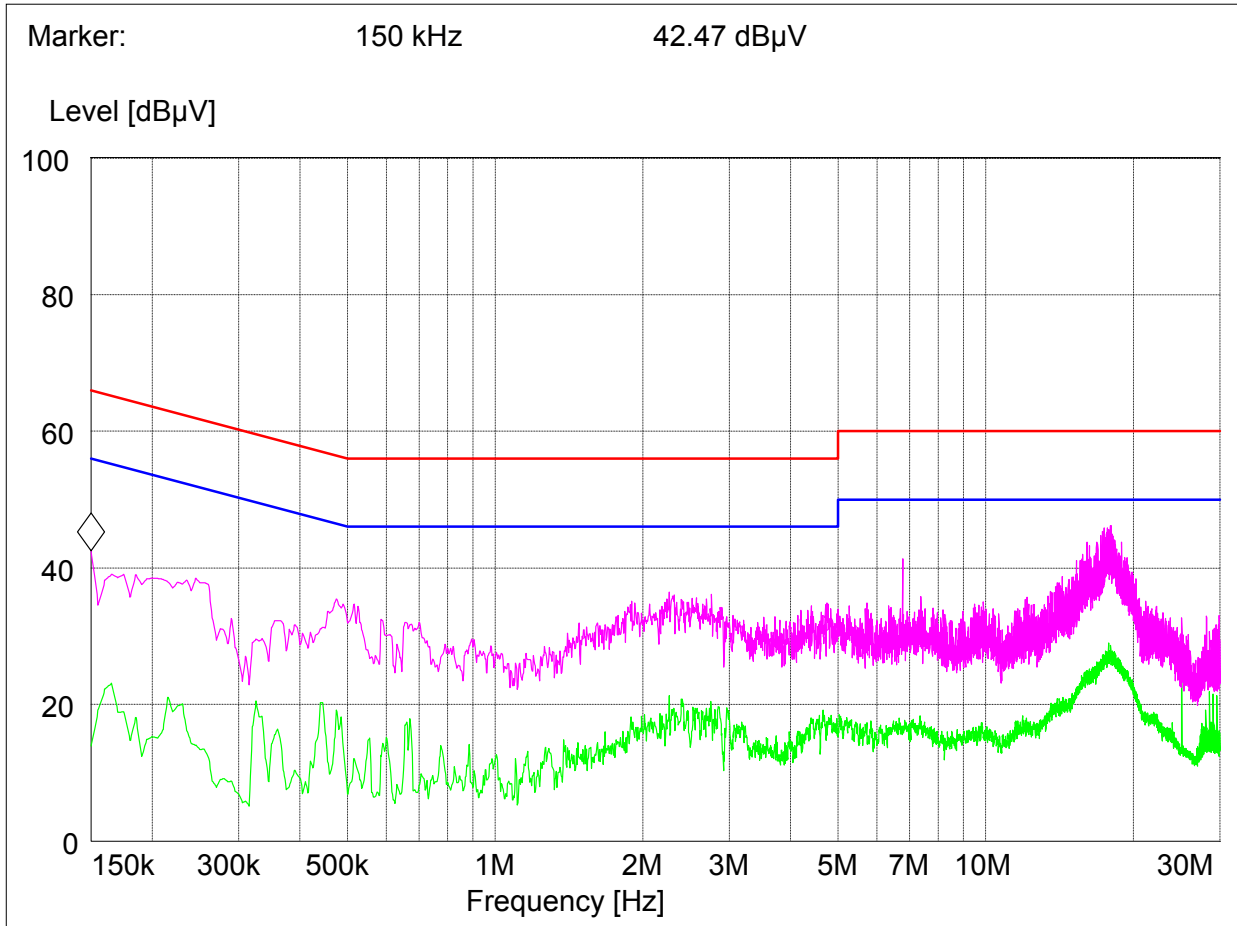

The results shown in this test report refer only to the sample(s) tested unless otherwise stated. This test report cannot be reproduced, except in full, without prior written permission of the Company.

Test mode : (Neutral)

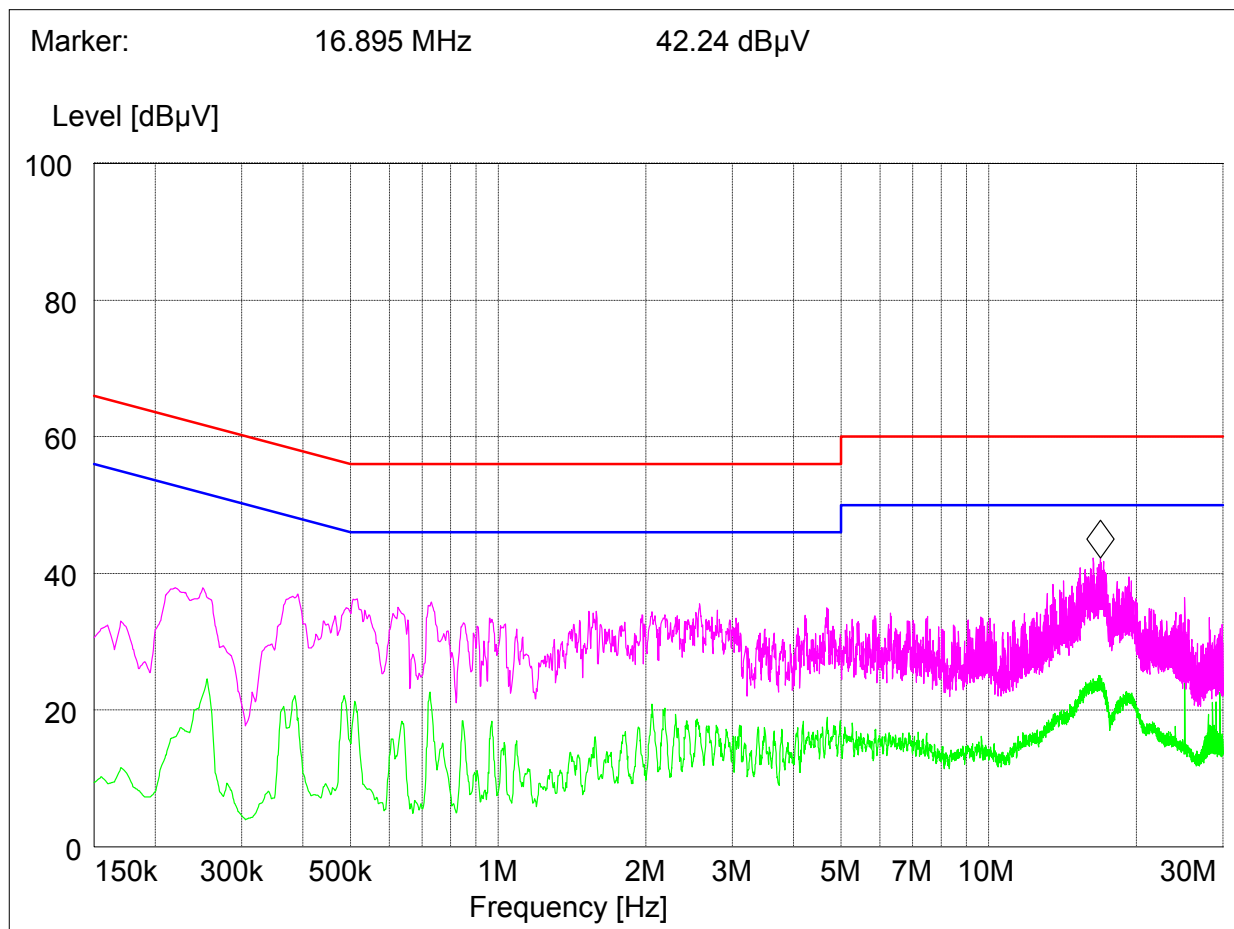

The results shown in this test report refer only to the sample(s) tested unless otherwise stated. This test report cannot be reproduced, except in full, without prior written permission of the Company.

## 11. Antenna Requirement

### 11.1. Standard Applicable

For intentional device, according to FCC 47 CFR Section §15.203, an intentional radiator shall be designed to ensure that no antenna other than that furnished by the responsible party shall be used with the device. And according to FCC 47 CFR Section §15.247 (b) if transmitting antennas of directional gain greater than 6 dB i are used, the power shall be reduced by the amount in dB that the gain of the antenna exceeds 6 dB i.

### 11.2. Antenna Connected Construction

Antenna used in this product is Integral type (Chip Antenna ) gain of 0.242 dB i.

---

*The results shown in this test report refer only to the sample(s) tested unless otherwise stated. This test report cannot be reproduced, except in full, without prior written permission of the Company.*

## 12. RF Exposure Evaluation

### 12.1 Environmental evaluation and exposure limit according to FCC CFR 47 part 1, 1.1307(b), 1.1310

According to FCC 1.1310 : The criteria listed in the following table shall be used to evaluate the environment impact of human exposure to radio frequency (RF) radiation as specified in §1.1307(b)

#### LIMITS FOR MAXIMUM PERMISSIBLE EXPOSURE (MPE)

Frequency Range (MHz)	Electric Field Strength(V/m)	Magnetic Field Strength (A/m)	Power Density (mW/cm <sup>2</sup> )	Average Time
(A) Limits for Occupational /Control Exposures				
300 – 1 500	--	--	F/300	6
1 500 – 100 000	--	--	5	6
(B) Limits for General Population/Uncontrol Exposures				
300 – 1 500	--	--	F/1500	6
<b><u>1 500 – 100 000</u></b>	--	--	<b><u>1</u></b>	<b><u>30</u></b>

#### 12.1.1. Friis transmission formula: $P_d = (P_{out} \cdot G) / (4 \cdot \pi \cdot R^2)$

Where  $P_d$  = power density in mW/cm<sup>2</sup>

$P_{out}$  = output power to antenna in mW

G = gain of antenna in linear scale

$\pi$  = 3.1416

R = distance between observation point and center of the radiator in cm

$P_d$  the limit of MPE, 1 mW/cm<sup>2</sup>. If we know the maximum gain of the antenna and the total power input to the antenna, through the calculation, we will know the distance where the MPE limit is reached.

*The results shown in this test report refer only to the sample(s) tested unless otherwise stated. This test report cannot be reproduced, except in full, without prior written permission of the Company.*

### 12.1.2. Test Result of RF Exposure Evaluation

Test Item : RF Exposure Evaluation Data

Test Mode : Normal Operation

### 12.1.3. Output Power into Antenna & RF Exposure Evaluation Distance

#### FHSS : GFSK (Inner battery)

Channel	Channel Frequency (MHz)	Output Average Power to Antenna (dB m)	Antenna Gain (dB i)	Power Density at 20 cm (mW/cm <sup>2</sup> )	LIMITS (mW/cm <sup>2</sup> )
Low	2 402	-4.06	0.242	0.000 08	1
Middle	2 441	-3.96	0.242	0.000 08	1
High	2 480	-4.61	0.242	0.000 07	1

#### FHSS : 8DPSK (Inner battery)

Channel	Channel Frequency (MHz)	Output Average Power to Antenna (dB m)	Antenna Gain (dB i)	Power Density at 20 cm (mW/cm <sup>2</sup> )	LIMITS (mW/cm <sup>2</sup> )
Low	2 402	-3.17	0.242	0.000 10	1
Middle	2 441	-3.47	0.242	0.000 09	1
High	2 480	-4.47	0.242	0.000 08	1

The results shown in this test report refer only to the sample(s) tested unless otherwise stated. This test report cannot be reproduced, except in full, without prior written permission of the Company.

**FHSS : GFSK (Micro USB)**

Channel	Channel Frequency (MHz)	Output Average Power to Antenna (dB m)	Antenna Gain (dB i)	Power Density at 20 cm (mW/cm <sup>2</sup> )	LIMITS (mW/cm <sup>2</sup> )
Low	2 402	-4.04	0.242	0.000 08	1
Middle	2 441	-3.95	0.242	0.000 08	1
High	2 480	-4.59	0.242	0.000 07	1

**FHSS : 8DPSK (Micro USB)**

Channel	Channel Frequency (MHz)	Output Average Power to Antenna (dB m)	Antenna Gain (dB i)	Power Density at 20 cm (mW/cm <sup>2</sup> )	LIMITS (mW/cm <sup>2</sup> )
Low	2 402	-3.14	0.242	0.000 10	1
Middle	2 441	-3.42	0.242	0.000 10	1
High	2 480	-4.42	0.242	0.000 08	1

## Note :

- The power density Pd (5th column) at a distance of 20 cm calculated from the friis transmission formula is far below the limit of 1 mW/cm<sup>2</sup> .

*The results shown in this test report refer only to the sample(s) tested unless otherwise stated. This test report cannot be reproduced, except in full, without prior written permission of the Company.*