

TEST REPORT

of

FCC Part 15 Subpart C §15.247/RSS-210 Issue 8, RSS-Gen Issue 3

FCC ID/IC Certification: A3LHS10/649E-EIHS10

Equipment Under Test : Bluetooth Body Scale
Model Name : EI-HS10
Serial No. : N/A
Applicant : Samsung Electronics Co., LTD.
Manufacturer : Samsung Electronics Co., LTD.
Date of Test(s) : 2013.05.15 ~ 2013.05.28
Date of Issue : 2013.05.29

In the configuration tested, the EUT complied with the standards specified above.

Tested By:



Date:

2013.05.29

Alvin Kim

Approved By:



Date:

2013.05.29

Hyunchoe You

The results shown in this test report refer only to the sample(s) tested unless otherwise stated. This test report cannot be reproduced, except in full, without prior written permission of the Company.

INDEX

<u>Table of Contents</u>	Page
1. General Information -----	3
2. Transmitter Radiated Spurious Emissions and Conducted Spurious Emission -----	7
3. 20 dB Bandwidth and 99% BW -----	30
4. Maximum Peak Output Power -----	42
5. Hopping Channel Separation -----	44
6. Number of Hopping Frequency -----	47
7. Time of Occupancy(Dwell Time) -----	51
8. Antenna Requirement -----	64

The results shown in this test report refer only to the sample(s) tested unless otherwise stated. This test report cannot be reproduced, except in full, without prior written permission of the Company.

1. General Information

1.1. Testing Laboratory

SGS Korea Co., Ltd. (Gunpo Laboratory)

- Wireless Div. 3FL, 18-34, Sanbon-dong, Gunpo-si, Gyeonggi-do, Korea 435-040

All SGS services are rendered in accordance with the applicable SGS conditions of service available on request and accessible at <http://www.sgs.com/en/Terms-and-Conditions.aspx>.

Telephone : +82 31 428 5700

FAX : +82 31 427 2371

1.2. Details of Applicant

Applicant : Samsung Electronics Co., LTD.

Address : 129, Samsung-ro, Yeongtong-gu, Suwon-si, Gyeonggi-do, 443-742 Republic of Korea

Contact Person : Kim, Hui-Kyeong

Phone No. : +82 10 8981 4871

1.3. Description of EUT

Kind of Product	Bluetooth Body Scale
Model Name	EI-HS10
Serial Number	N/A
Power Supply	DC 4.5 V
Frequency Range	2 402 MHz ~ 2 480 MHz
Modulation Technique	GFSK, $\pi/4$ DQPSK, 8DPSK
Number of Channels	79
Antenna Type	Internal type
Antenna Gain	3.1 dBi
H/W Version	REV 1.1
S/W Version	bw130m_V1.29.saf

1.4. Declaration by the manufacturer

- Adaptive Frequency Hopping is supported and use at least 20 channels

The results shown in this test report refer only to the sample(s) tested unless otherwise stated. This test report cannot be reproduced, except in full, without prior written permission of the Company.

SGS Korea Co., Ltd. (Gunpo Laboratory) 18-34, Sanbon-dong, Gunpo-si, Gyeonggi-do, Korea, 435-040

Tel. +82 31 428 5700 / Fax. +82 31 427 2371

www.ee.sgs.com/korea

1.5. Information about the FHSS characteristics:

1.5.1. Pseudorandom Frequency Hopping Sequence

The channel is represented by a pseudo-random hopping sequence hopping through the 79 RF channels. The hopping sequence is unique for the piconet and is determined by the Bluetooth device address of the master; the phase in the hopping sequence is determined by the Bluetooth clock of the master. The channel is divided into time slots where each slot corresponds to an RF hop frequency. Consecutive hops correspond to different RF hop frequencies. The nominal hop rate is 1 600 hops/s.

1.5.2. Equal Hopping Frequency Use

All Bluetooth units participating in the piconet are time and hop-synchronized to the channel.

1.5.3. System Receiver Input Bandwidth

Each channel bandwidth is 1 MHz

1.5.4. Equipment Description

15.247(a)(1) that the rx input bandwidths shift frequencies in synchronization with the transmitted

15.247(g): In accordance with the Bluetooth Industry Standard, the system is designed to comply with all of the regulations in Section 15.247 when the transmitter is presented with a continuous data (or information) system.

15.247(h): In accordance with the Bluetooth Industry Standard, the system does not coordinate its channels selection/ hopping sequence with other frequency hopping systems for the express purpose of avoiding the simultaneous occupancy of individual hopping frequencies by multiple transmitters.

The results shown in this test report refer only to the sample(s) tested unless otherwise stated. This test report cannot be reproduced, except in full, without prior written permission of the Company.

1.6. Test Equipment List

Equipment	Manufacturer	Model	S/N	Cal Date	Cal Interval	Cal Due.
Signal Generator	R&S	SMR40	100272	Aug. 23, 2012	Annual	Aug. 23, 2013
Spectrum Analyzer	Agilent	N9030A	US51350132	Oct. 30, 2012	Annual	Oct. 30, 2013
Spectrum Analyzer	R&S	FSV30	100768	Mar. 28, 2013	Annual	Mar. 28, 2014
Bluetooth Tester	TESOM	TC-3000C	3000C000142	Dec. 24, 2012	Annual	Dec. 24, 2013
Bluetooth Tester	R&S	CBT 32	100300	Jun. 12, 2012	Annual	Jun. 12, 2013
Directional Coupler	KRYTAR	152613	122660	Jul. 19, 2012	Annual	Jul. 19, 2013
High Pass Filter	Wainwright	WHK3.0/18G-10SS	344	Sep. 12, 2012	Annual	Sep. 12, 2013
High Pass Filter	Wainwright	WHK7.5/26.5G-6SS	N/A	Jul. 12, 2012	Annual	Jul. 12, 2013
Low Pass Filter	Mini circuits	NLP-1200+	V8979400903-1	Jul. 12, 2012	Annual	Jul. 12, 2013
Power Sensor	R&S	NRP-Z81	100748	Jul. 10, 2012	Annual	Jul. 10, 2013
DC Power Supply	Agilent	6553A	MY40000695	Jul. 02, 2012	Annual	Jul. 02, 2013
Preamplifier	H.P.	8447F	2944A03909	Jul. 04, 2012	Annual	Jul. 03, 2013
Preamplifier	R&S	SCU 18	10117	Jan. 14, 2013	Annual	Jan. 14, 2014
Preamplifier	MITEQ Inc.	JS44-18004000-35-8P	1546891	Jul. 12, 2012	Annual	Jul. 12, 2013
Test Receiver	R&S	ESU26	100109	Feb. 28, 2013	Annual	Feb. 28, 2014
Bilog Antenna	SCHWARZBECK MESSELEKTRONIK	VULB9163	390	Apr. 19, 2012	Biennial	Apr. 19, 2014
Loop Antenna	R&S	HFH2-Z2	100118	Aug. 24, 2011	Biennial	Aug. 24, 2013
Horn Antenna	R&S	HF906	100326	Nov. 23, 2011	Biennial	Nov. 23, 2013
Horn Antenna	SCHWARZBECK MESSELEKTRONIK	BBHA9170	BBHA9170431	May 15, 2012	Biennial	May 15, 2014
Antenna Master	INN-CO	MM4000	N/A	N.C.R.	N/A	N.C.R.
Turn Table	INN-CO	DS 1200S	N/A	N.C.R.	N/A	N.C.R.
Anechoic Chamber	SY Corporation	L x W x H (9.6 m x 6.4 m x 6.6 m)	N/A	N.C.R.	N/A	N.C.R.

The results shown in this test report refer only to the sample(s) tested unless otherwise stated. This test report cannot be reproduced, except in full, without prior written permission of the Company.

1.7. Summary of Test Results

The EUT has been tested according to the following specifications:

APPLIED STANDARD:FCC Part15 subpart C, RSS-210, RSS-Gen			
Section in FCC 15	Section in RSS-210	Test Item	Result
15.205(a) 15.209 15.247(d)	RSS-210 A8.5	Transmitter Radiated Spurious Emissions Conducted Spurious Emission	Complied
15.247(a)(1)	RSS-210 A8.1(a) RSS-Gen 4.6.1	20 dB Bandwidth and 99% BW	Complied
15.247(b)(1)	RSS-210 A8.4(2)	Maximum Peak Output Power	Complied
15.247(a)(1)	RSS-210 A8.1(b)	Frequency Separation	Complied
15.247(a)(1)(iii)	RSS-210 A8.4(2)	Number of Hopping Frequency	Complied
15.247(a)(1)(iii)	RSS-210 A8.1(d)	Time of Occupancy (Dwell Time)	Complied

1.8. Sample calculation

Where relevant, the following sample calculation is provided:

1.8.1. Conducted test

Offset value (dB) = Directional Coupler(dB) + Cable loss (dB)

1.8.2. Radiation test

Field strength level (dB μ V/m) = Measured level (dB μ V) + Antenna factor (dB) + Cable loss (dB) – amplifier gain (dB)

1.9. Test report revision

Revision	Report number	Description
0	F690501/RF-RTL006579	Initial

The results shown in this test report refer only to the sample(s) tested unless otherwise stated. This test report cannot be reproduced, except in full, without prior written permission of the Company.

2. Transmitter Radiated Spurious Emissions and Conducted Spurious Emission

2.1. Test Setup

2.1.1. Transmitter Radiated Spurious Emissions

The diagram below shows the test setup that is utilized to make the measurements for emission from 30 MHz to 1 GHz Emissions.

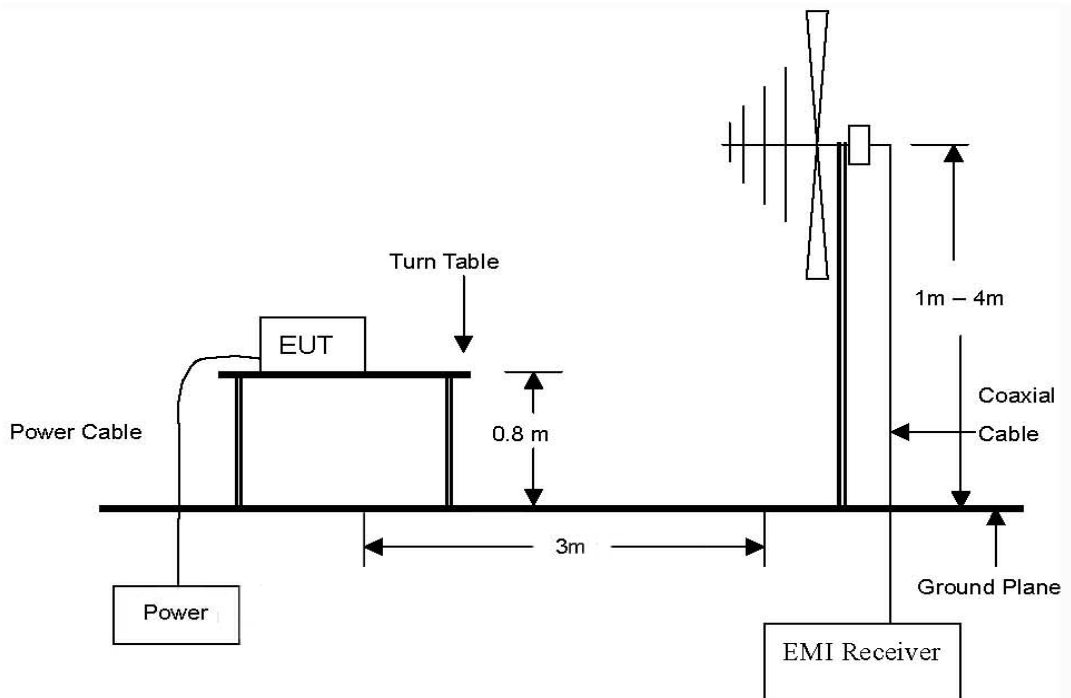

The diagram below shows the test setup that is utilized to make the measurements for emission. The spurious emissions were investigated from 1 GHz to the 10th harmonic of the highest fundamental frequency or 40 GHz, whichever is lower.

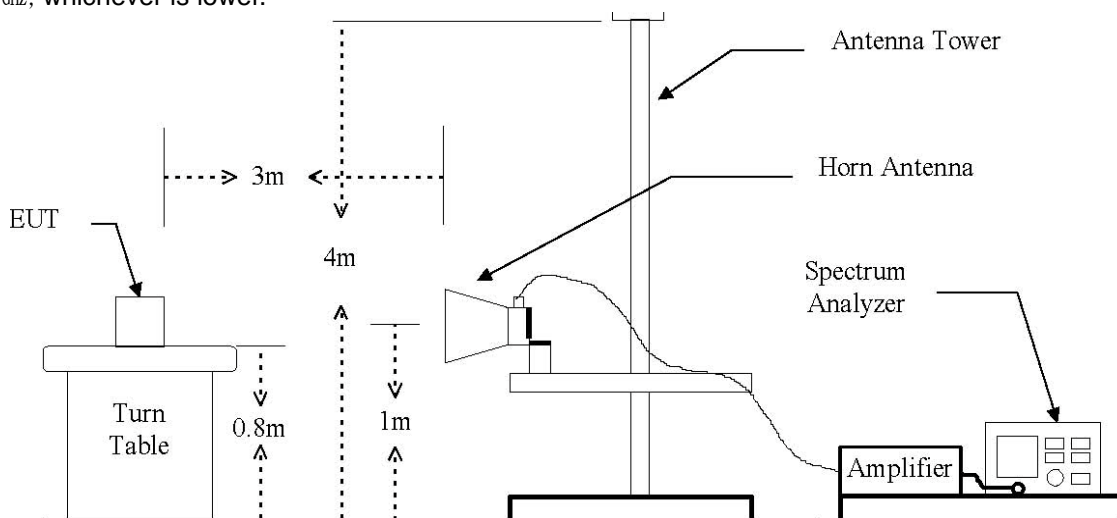

The results shown in this test report refer only to the sample(s) tested unless otherwise stated. This test report cannot be reproduced, except in full, without prior written permission of the Company.

2.1.2. Conducted Spurious Emissions

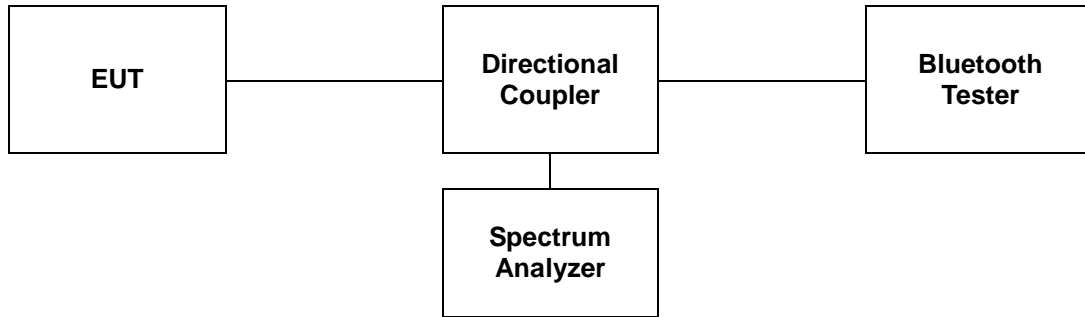

2.2. Limit

According to §15.247(d), in any 100 kHz bandwidth outside the frequency band in which the spread spectrum or digitally modulated intentional radiator is operating, the radio frequency power that is produced by the intentional radiator shall be at least 20 dB below that in the 100 kHz bandwidth within the band that contains the highest level of the desired power, based on either an RF conducted or a radiated measurement, provided the transmitter demonstrates compliance with the peak conducted power limits. If the transmitter complies with the conducted power limits based on the use of RMS averaging over a time interval, as permitted under paragraph(b)(3) of this section, the attenuation required under this paragraph shall be 30 dB instead of 20 dB. Attenuation below the general limits specified in section §15.209(a) is not required. In addition, radiated emission which in the restricted band, as define in section §15.205(a), must also comply the radiated emission limits specified in section §15.209(a) (see section §15.205(c))

According to § 15.209(a), Except as provided elsewhere in this Subpart, the emissions from an intentional radiator shall not exceed the field strength levels specified in the following table :

Frequency (MHz)	Distance (Meters)	Field Strength (dB µV/m)	Field Strength (µV/m)
30 - 88	3	40.0	100
88 – 216	3	43.5	150
216 – 960	3	46.0	200
Above 960	3	54.0	500

The results shown in this test report refer only to the sample(s) tested unless otherwise stated. This test report cannot be reproduced, except in full, without prior written permission of the Company.

2.3. Test Procedures

Radiated emissions from the EUT were measured according to the dictates of DA000705 and ANSI C63.4 2003

2.3.1. Test Procedures for Radiated Spurious Emissions

1. The EUT was placed on the top of a rotating table 0.8 meters above the ground at a 3 meter anechoic chamber test site. The table was rotated 360 degrees to determine the position of the highest radiation.
2. During performing radiated emission below 1 GHz, the EUT was set 3 meters away from the interference receiving antenna, which was mounted on the top of a variable-height antenna tower. During performing radiated emission above 1 GHz, the EUT was set 3 meter away from the interference-receiving antenna.
3. The antenna is a broadband antenna, and its height is varied from one meter to four meters above the ground to determine the maximum value of the field strength. Both horizontal and vertical polarizations of the antenna are set to make the measurement.
4. For each suspected emission, the EUT was arranged to its worst case and then the antenna was tuned to heights from 1 meter to 4 meters and the table was turned from 0 degrees to 360 degrees to find the maximum reading.
5. The test-receiver system was set to Peak Detect Function and Specified Bandwidth with Maximum Hold Mode.
6. If the emission level of the EUT in peak mode was 10 dB lower than the limit specified, then testing could be stopped and the peak values of the EUT would be reported. Otherwise the emissions that did not have 10 dB margin would be re-tested one by one using peak, quasi-peak or average method as specified and then reported in a data sheet.

NOTE;

All data rates and modes were investigated for radiated spurious emissions. Only the radiated emissions of the configuration that produced the worst case emissions are reported in this section.

1. The resolution bandwidth and video bandwidth of test receiver/spectrum analyzer is 120 kHz for Peak detection (PK) and Quasi-peak detection (QP) at frequency below 1 GHz.
2. The resolution bandwidth and video bandwidth of test receiver/spectrum analyzer is 1 MHz for Peak detection and frequency above 1 GHz.
3. The resolution bandwidth of test receiver/spectrum analyzer is 1 MHz and the video bandwidth is 10 Hz for Average detection (AV) at frequency above 1 GHz.
4. When Average result is different from peak result over 20 dB (over-averaging), According to 15.35 (c), as a "duty cycle correction factor", pulse averaging with 20 log(duty cycle) has to be used.
5. To get a maximum emission level from the EUT, the EUT is manipulated through three orthogonal planes.

The results shown in this test report refer only to the sample(s) tested unless otherwise stated. This test report cannot be reproduced, except in full, without prior written permission of the Company.

2.3.2. Test Procedures for Conducted Spurious Emissions

2.3.2.1. Band-edge Compliance of RF Conducted Emissions

The transmitter output was connected to the spectrum analyzer.

Span = wide enough to capture the peak level of the emission operating on the channel closest to the bandedge, as well as any modulation products which fall outside of the authorized band of operation.

RBW \geq 100 kHz

VBW \geq RBW

Sweep = auto

Detector function = peak

Trace = max hold

2.3.2.2. Spurious RF Conducted Emissions

The transmitter output was connected to the spectrum analyzer.

RBW = 100 kHz

VBW \geq RBW

Sweep = auto

Detector function = peak

Trace = max hold

The results shown in this test report refer only to the sample(s) tested unless otherwise stated. This test report cannot be reproduced, except in full, without prior written permission of the Company.

2.4. Test Results

Ambient temperature : (23 ± 2) °C
 Relative humidity : 47 % R.H.

2.4.1. Spurious Radiated Emission (Worst case configuration_ GFSK mode, 1 Mbps, Middle channel)

The frequency spectrum from 9 kHz to 1 000 MHz was investigated. Emission levels are not reported much lower than the limits by over 30 dB. All reading values are peak values.

Radiated Emissions			Ant	Correction Factors		Total	FCC Limit	
Frequency (MHz)	Reading (dBμV)	Detect Mode	Pol.	AF (dB/m)	AMP + CL (dB)	Actual (dBμV/m)	Limit (dBμV/m)	Margin (dB)
30.0	36.8	Peak	H	10.4	-26.8	20.4	40.0	19.6
184.0	37.2	Peak	H	8.9	-25.3	20.8	43.5	22.7
208.0	36.4	Peak	H	10.4	-25.1	21.7	43.5	21.8
224.0	38.1	Peak	H	11.3	-25.0	24.4	46.0	21.6
250.8	40.2	Peak	H	12.9	-24.8	28.3	46.0	17.7
Above 300.0	Not detected	-	-	-	-	-	-	-

Remark:

1. All spurious emissions at channels are almost the same below 1 GHz, so that middle channel was chosen at representative in final test.
2. Actual = Reading + AF + AMP + CL

The results shown in this test report refer only to the sample(s) tested unless otherwise stated. This test report cannot be reproduced, except in full, without prior written permission of the Company.

2.4.2. Spurious Radiated Emission

The frequency spectrum above 1 000 MHz was investigated. Emission levels are not reported much lower than the limits by over 30 dB.

Operating Mode: GFSK(1 Mbps)

A. Low Channel (2 402 MHz)

Radiated Emissions			Ant	Correction Factors		Total	FCC Limit	
Frequency (MHz)	Reading (dB μ V)	Detect Mode	Pol.	AF (dB/m)	CL (dB)	Actual (dB μ V/m)	Limit (dB μ V/m)	Margin (dB)
*2 390.00	23.72	Peak	H	28.05	7.56	59.33	74.00	14.67
*2 390.00	13.85	Average	H	28.05	7.56	49.46	54.00	4.54

Radiated Emissions			Ant	Correction Factors		Total	FCC Limit	
Frequency (MHz)	Reading (dB μ V)	Detect Mode	Pol.	AF (dB/m)	AMP+CL (dB)	Actual (dB μ V/m)	Limit (dB μ V/m)	Margin (dB)
*4 804.02	47.92	Peak	H	32.28	-32.66	47.54	74.00	26.46
*4 804.02	44.99	Average	H	32.28	-32.66	44.61	54.00	9.39
Above 4 900.00	Not detected	-	-	-	-	-	-	-

The results shown in this test report refer only to the sample(s) tested unless otherwise stated. This test report cannot be reproduced, except in full, without prior written permission of the Company.

B. Middle Channel (2 441 MHz)

Radiated Emissions			Ant	Correction Factors		Total	FCC Limit	
Frequency (MHz)	Reading (dB μ V)	Detect Mode	Pol.	AF (dB/m)	AMP+CL (dB)	Actual (dB μ V/m)	Limit (dB μ V/m)	Margin (dB)
*4 881.90	49.98	Peak	H	32.85	-32.41	50.42	74.00	23.58
*4 881.90	47.43	Average	H	32.85	-32.41	47.87	54.00	6.13
Above 4 900.00	Not detected	-	-	-	-	-	-	-

C. High Channel (2 480 MHz)

Radiated Emissions			Ant	Correction Factors		Total	FCC Limit	
Frequency (MHz)	Reading (dB μ V)	Detect Mode	Pol.	AF (dB/m)	CL (dB)	Actual (dB μ V/m)	Limit (dB μ V/m)	Margin (dB)
*2 483.50	23.90	Peak	H	28.31	7.67	59.88	74.00	14.12
*2 483.50	14.27	Average	H	28.31	7.67	50.25	54.00	3.75

Radiated Emissions			Ant	Correction Factors		Total	FCC Limit	
Frequency (MHz)	Reading (dB μ V)	Detect Mode	Pol.	AF (dB/m)	AMP+CL (dB)	Actual (dB μ V/m)	Limit (dB μ V/m)	Margin (dB)
*4 959.72	53.96	Peak	H	33.31	-32.27	55.00	74.00	19.00
*4 959.72	49.81	Average	H	33.31	-32.27	50.85	54.00	3.15
Above 5 000.00	Not detected	-	-	-	-	-	-	-

The results shown in this test report refer only to the sample(s) tested unless otherwise stated. This test report cannot be reproduced, except in full, without prior written permission of the Company.

Operating Mode: 8DPSK(3 Mbps)

A. Low Channel (2 402 MHz)

Radiated Emissions			Ant	Correction Factors		Total	FCC Limit	
Frequency (MHz)	Reading (dB μ V)	Detect Mode	Pol.	AF (dB/m)	CL (dB)	Actual (dB μ V/m)	Limit (dB μ V/m)	Margin (dB)
*2 390.00	23.96	Peak	H	28.05	7.56	59.57	74.00	14.43
*2 390.00	13.88	Average	H	28.05	7.56	49.49	54.00	4.51

Radiated Emissions			Ant	Correction Factors		Total	FCC Limit	
Frequency (MHz)	Reading (dB μ V)	Detect Mode	Pol.	AF (dB/m)	AMP+CL (dB)	Actual (dB μ V/m)	Limit (dB μ V/m)	Margin (dB)
*4 804.05	42.96	Peak	H	32.28	-32.66	42.58	74.00	31.42
*4 804.05	34.29	Average	H	32.28	-32.66	33.91	54.00	20.10
Above 4 900.00	Not detected	-	-	-	-	-	-	-

B. Middle Channel (2 441 MHz)

Radiated Emissions			Ant	Correction Factors		Total	FCC Limit	
Frequency (MHz)	Reading (dB μ V)	Detect Mode	Pol.	AF (dB/m)	AMP+CL (dB)	Actual (dB μ V/m)	Limit (dB μ V/m)	Margin (dB)
*4 882.06	44.79	Peak	H	32.85	-32.41	45.23	74.00	28.77
*4 882.06	37.56	Average	H	32.85	-32.41	38.00	54.00	16.00
Above 4 900.00	Not detected	-	-	-	-	-	-	-

The results shown in this test report refer only to the sample(s) tested unless otherwise stated. This test report cannot be reproduced, except in full, without prior written permission of the Company.

C. High Channel (2 480 MHz)

Radiated Emissions			Ant	Correction Factors		Total	FCC Limit	
Frequency (MHz)	Reading (dB μ V)	Detect Mode	Pol.	AF (dB/m)	CL (dB)	Actual (dB μ V/m)	Limit (dB μ V/m)	Margin (dB)
*2 483.50	23.87	Peak	H	28.31	7.67	59.85	74.00	14.15
*2 483.50	14.40	Average	H	28.31	7.67	50.38	54.00	3.62

Radiated Emissions			Ant	Correction Factors		Total	FCC Limit	
Frequency (MHz)	Reading (dB μ V)	Detect Mode	Pol.	AF (dB/m)	AMP+CL (dB)	Actual (dB μ V/m)	Limit (dB μ V/m)	Margin (dB)
*4 960.29	46.66	Peak	H	33.31	-32.27	47.70	74.00	26.30
*4 960.29	42.01	Average	H	33.31	-32.27	43.05	54.00	10.95
Above 5 000.00	Not detected	-	-	-	-	-	-	-

Remarks:

1. "*" means the restricted band.
2. Measuring frequencies from 1 GHz to the 10th harmonic of highest fundamental frequency.
3. Radiated emissions measured in frequency above 1 000 MHz were made with an instrument using peak/average detector mode.
4. Average test would be performed if the peak results were greater than the average limit.
5. Actual = Reading + AF + AMP + CL

The results shown in this test report refer only to the sample(s) tested unless otherwise stated. This test report cannot be reproduced, except in full, without prior written permission of the Company.

2.4.3. Spurious RF Conducted Emissions: Plot of Spurious RF Conducted Emission

Operating Mode: GFSK(1 Mbps)

Low Channel

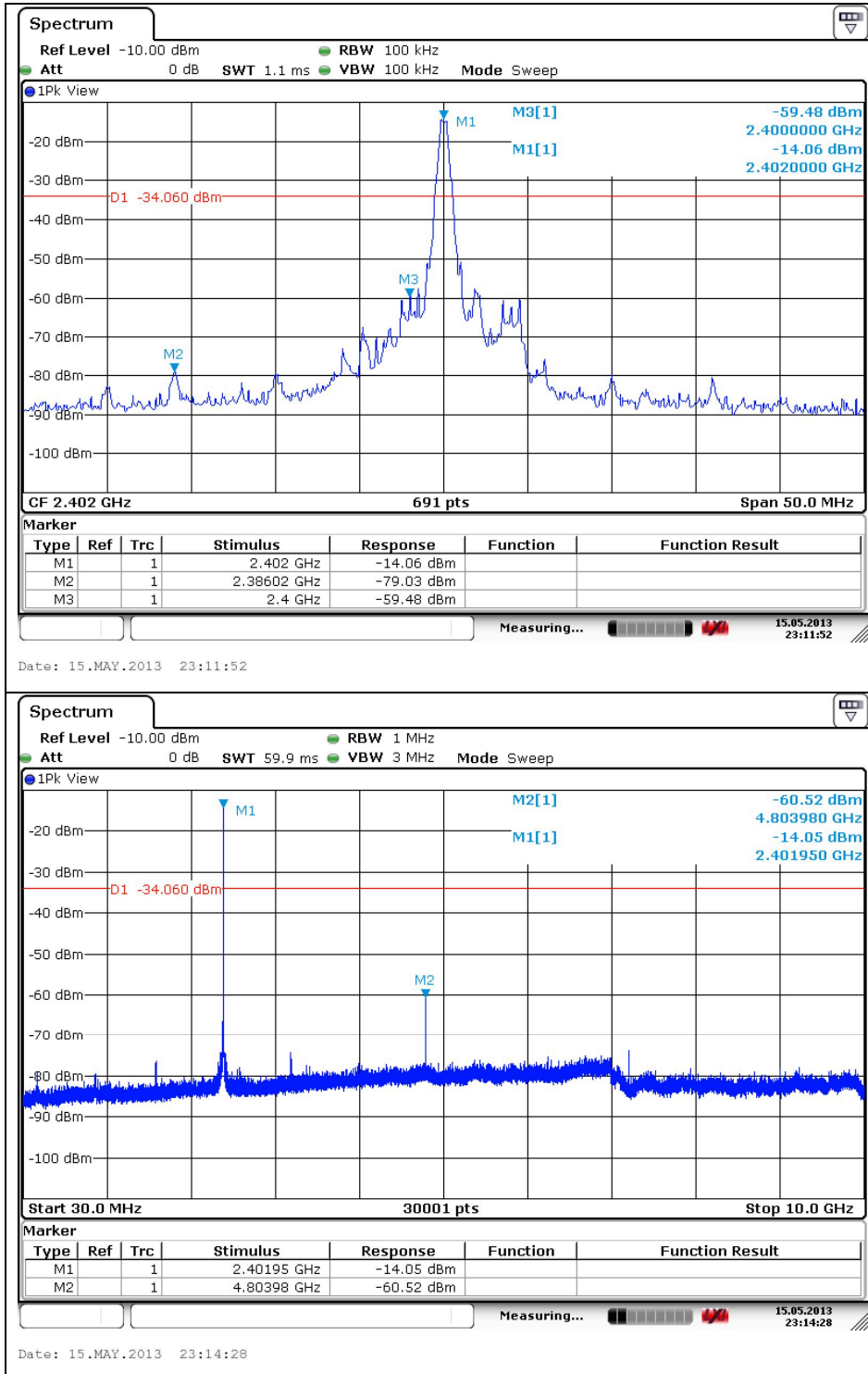

The results shown in this test report refer only to the sample(s) tested unless otherwise stated. This test report cannot be reproduced, except in full, without prior written permission of the Company.

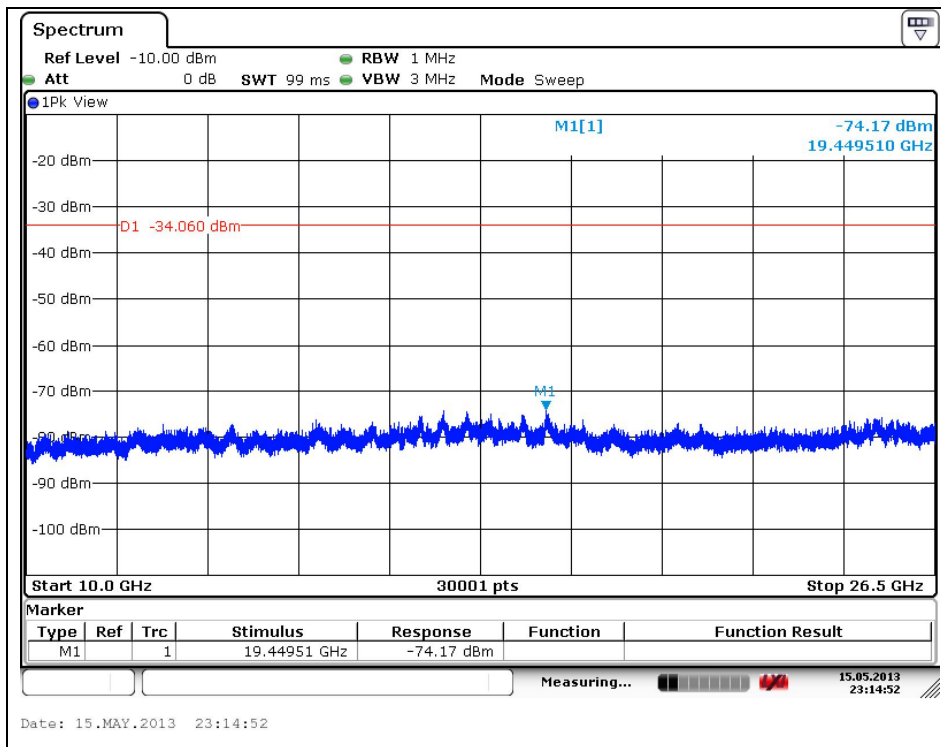

Note:

Offset (dB) = Directional Coupler(dB) + Cable loss (dB)

Final Result (dB m) = Reading values (dB m) + Spurious offset (dB)

Frequency (MHz)	Reading values (dB m)	Spurious offset (dB)	Final Result (dB m)
2 386.02	-79.03	16.94	-62.09
2 400.00	-59.48	16.99	-42.49
4 803.98	-60.52	17.83	-42.69
19 449.51	Noise floor	-	-

The results shown in this test report refer only to the sample(s) tested unless otherwise stated. This test report cannot be reproduced, except in full, without prior written permission of the Company.

Middle Channel

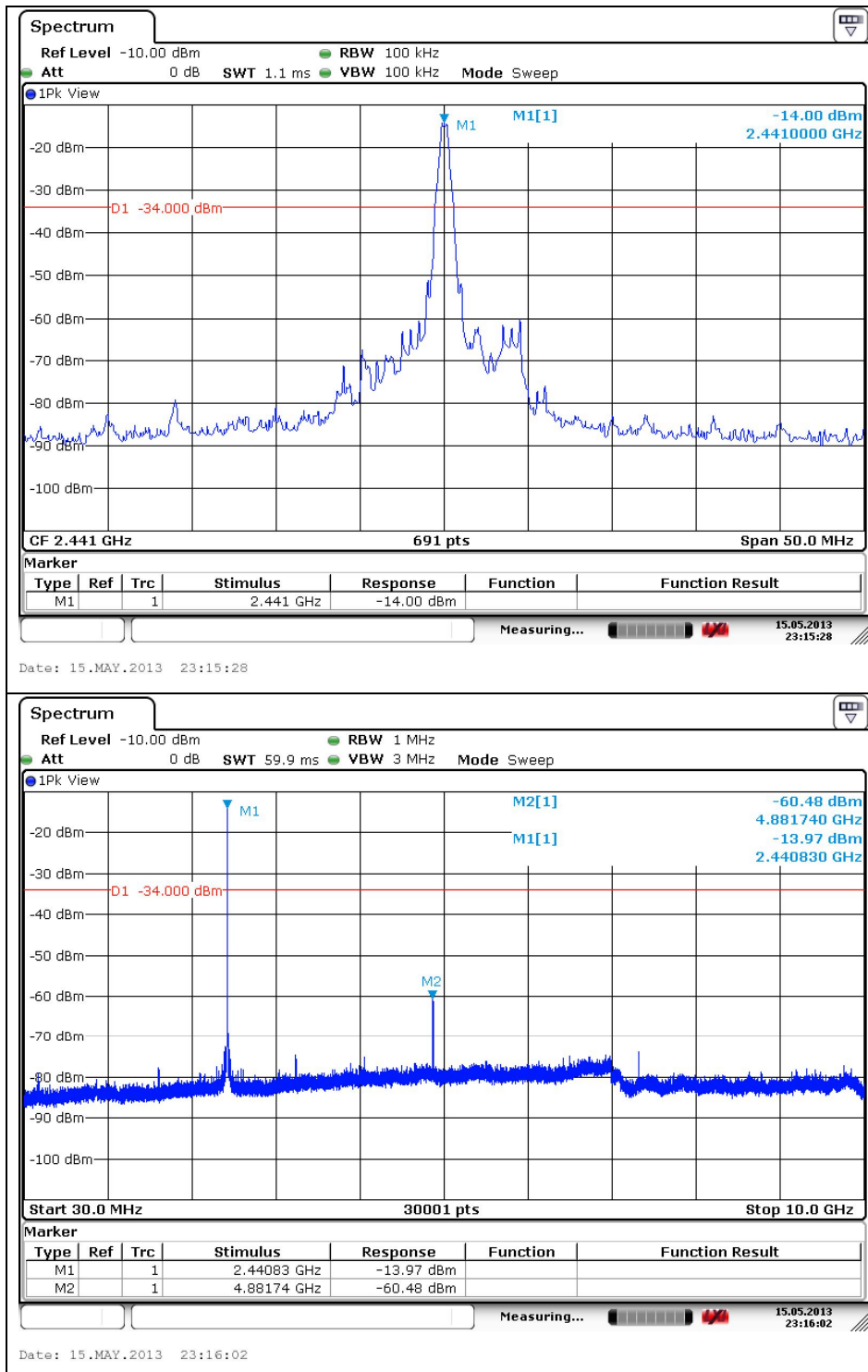

The results shown in this test report refer only to the sample(s) tested unless otherwise stated. This test report cannot be reproduced, except in full, without prior written permission of the Company.

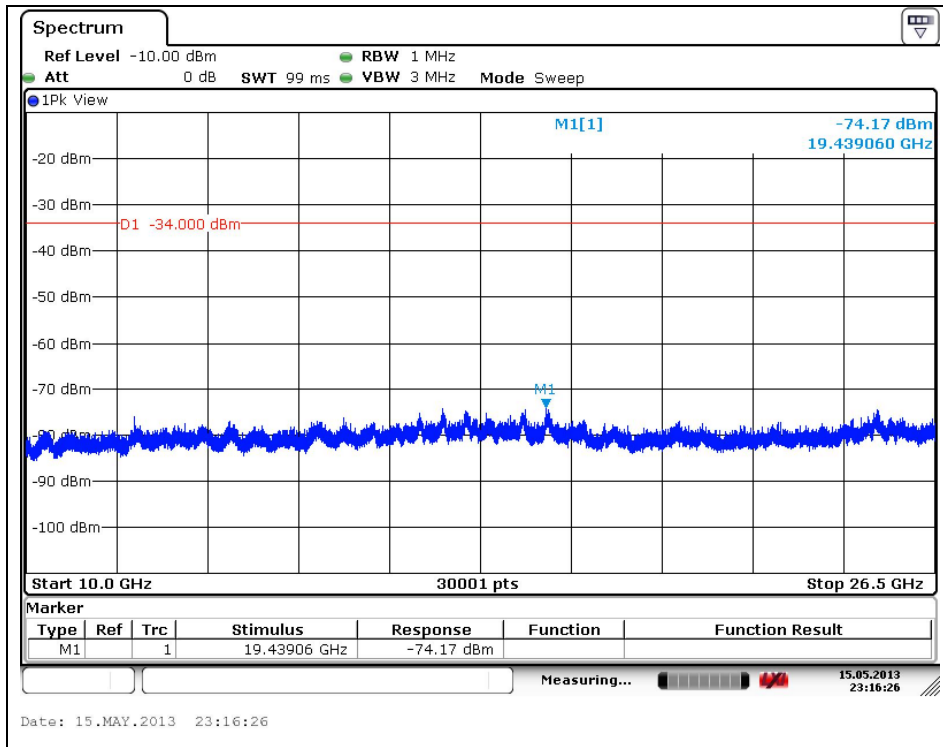

Note:

Offset (dB) = Directional Coupler(dB) + Cable loss (dB)

Final Result (dB m) = Reading values (dB m) + Spurious offset (dB)

Frequency (MHz)	Reading values (dB m)	Spurious offset (dB)	Final Result (dB m)
4 881.74	-60.48	17.59	-42.89
19 439.06	Noise floor	-	-

The results shown in this test report refer only to the sample(s) tested unless otherwise stated. This test report cannot be reproduced, except in full, without prior written permission of the Company.

High Channel

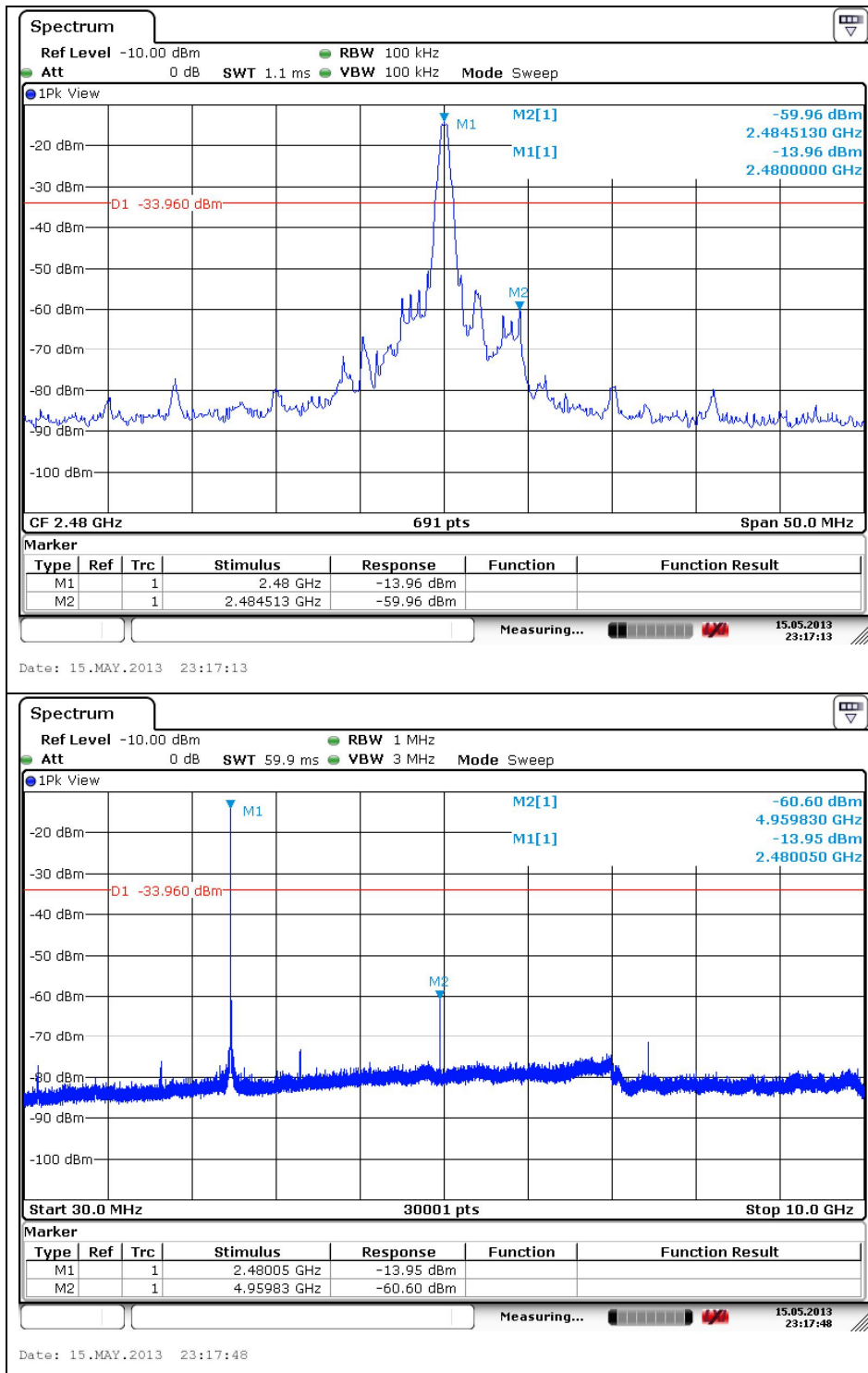

The results shown in this test report refer only to the sample(s) tested unless otherwise stated. This test report cannot be reproduced, except in full, without prior written permission of the Company.

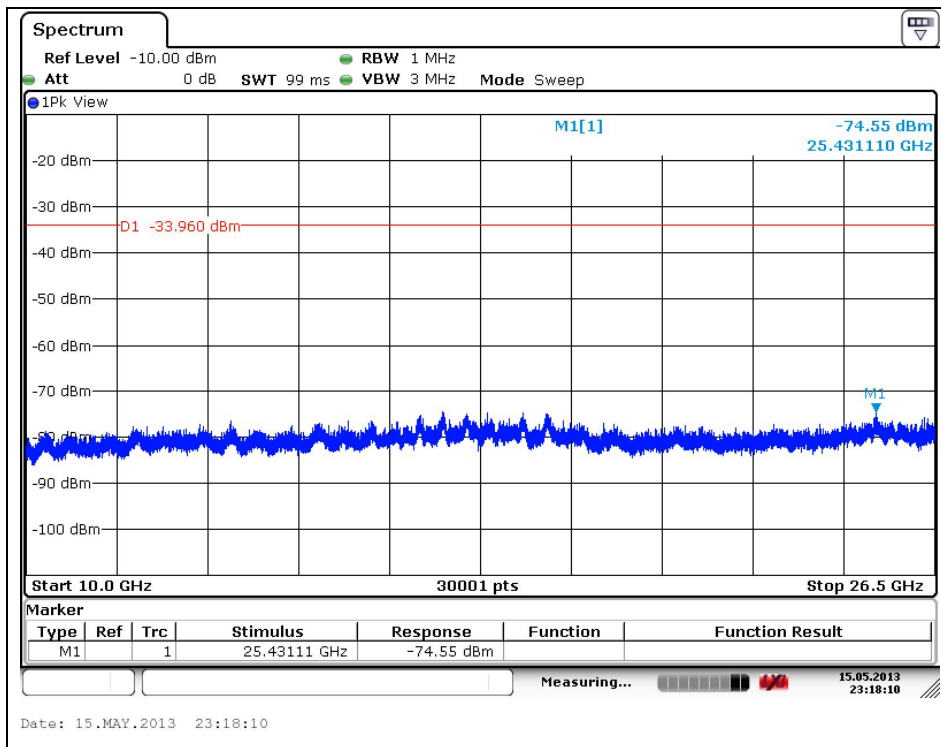

Note:

Offset (dB) = Directional Coupler(dB) + Cable loss (dB)

Final Result (dB m) = Reading values (dB m) + Spurious offset (dB)

Frequency (MHz)	Reading values (dB m)	Spurious offset (dB)	Final Result (dB m)
2 484.51	-59.96	16.94	-43.02
4 959.83	-60.60	17.91	-42.69
25 431.11	Noise floor	-	-

The results shown in this test report refer only to the sample(s) tested unless otherwise stated. This test report cannot be reproduced, except in full, without prior written permission of the Company.

Band edge at Hopping

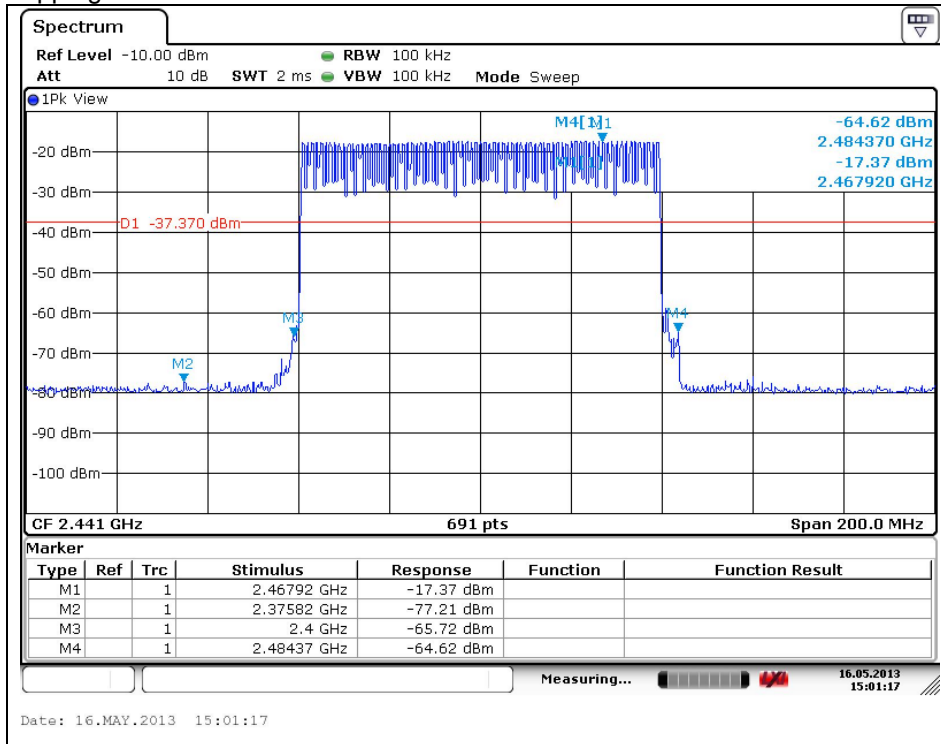

Note:

Offset (dB) = Directional Coupler(dB) + Cable loss (dB)

Final Result (dB m) = Reading values (dB m) + Spurious offset (dB)

Frequency (MHz)	Reading values (dB m)	Spurious offset (dB)	Final Result (dB m)
2 375.82	-77.21	16.94	-60.27
2 400.00	-65.72	16.99	-48.73
2 484.37	-64.62	16.94	-47.68

The results shown in this test report refer only to the sample(s) tested unless otherwise stated. This test report cannot be reproduced, except in full, without prior written permission of the Company.

Operating Mode : 8DPSK(3 Mbps)

Low Channel

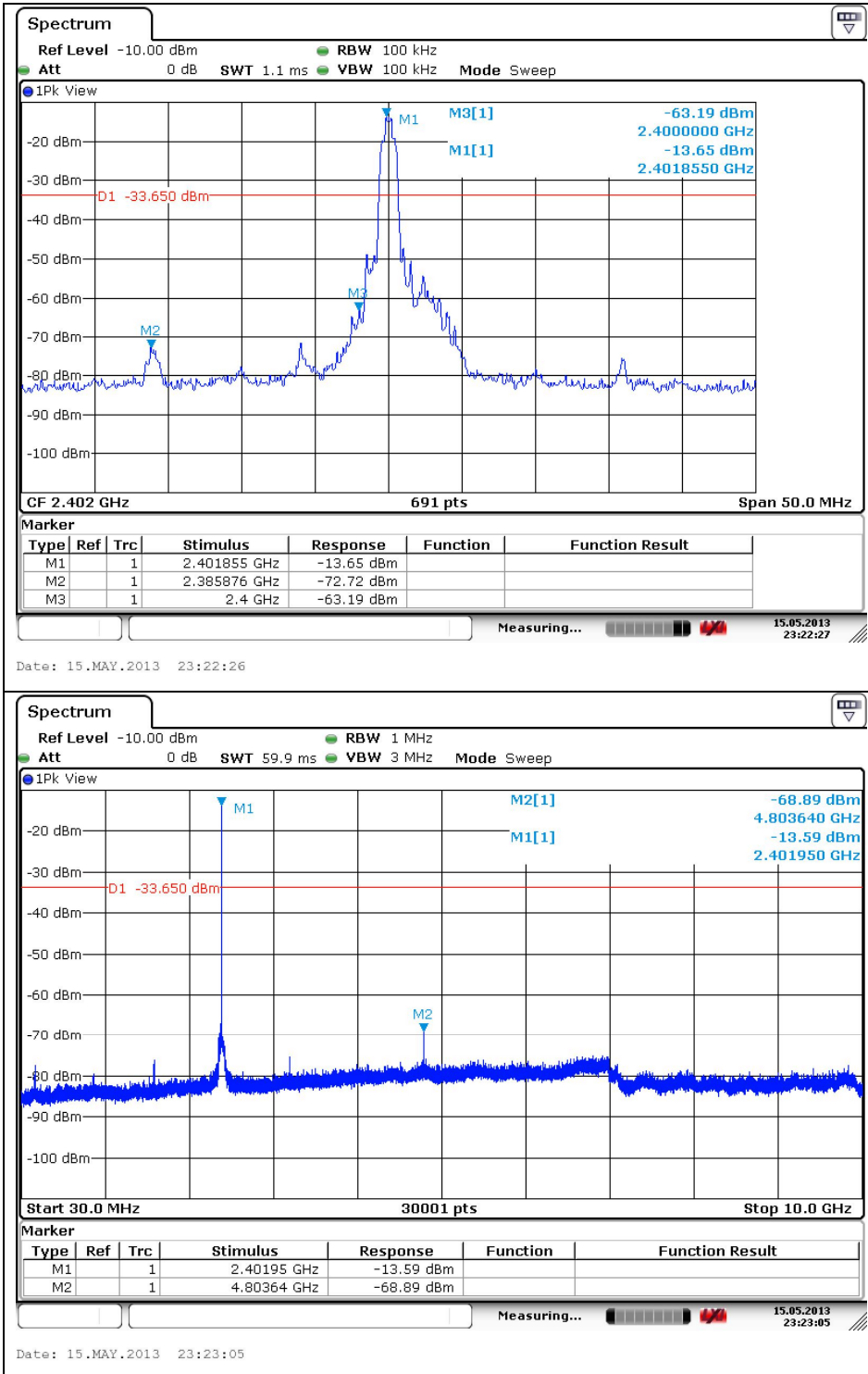

The results shown in this test report refer only to the sample(s) tested unless otherwise stated. This test report cannot be reproduced, except in full, without prior written permission of the Company.

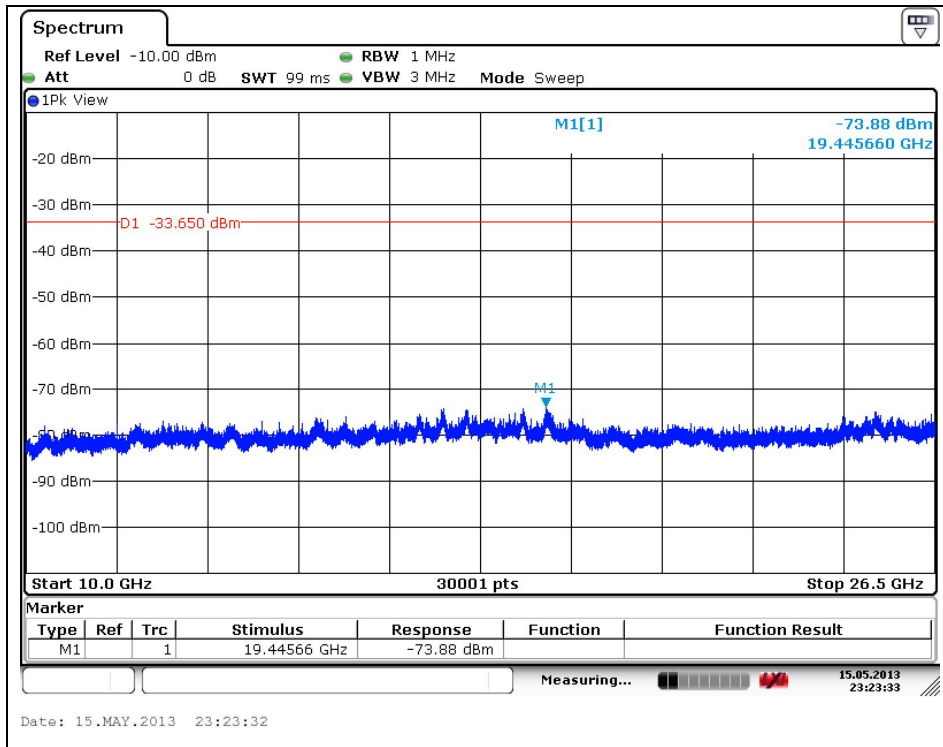

Note:

Offset (dB) = Directional Coupler(dB) + Cable loss (dB)

Final Result (dB m) = Reading values (dB m) + Spurious offset (dB)

Frequency (MHz)	Reading values (dB m)	Spurious offset (dB)	Final Result (dB m)
2 385.88	-72.72	16.94	-55.78
2 400.00	-63.19	16.99	-46.20
4 803.64	-68.89	17.83	-51.06
19 445.66	Noise floor	-	-

The results shown in this test report refer only to the sample(s) tested unless otherwise stated. This test report cannot be reproduced, except in full, without prior written permission of the Company.

Middle Channel

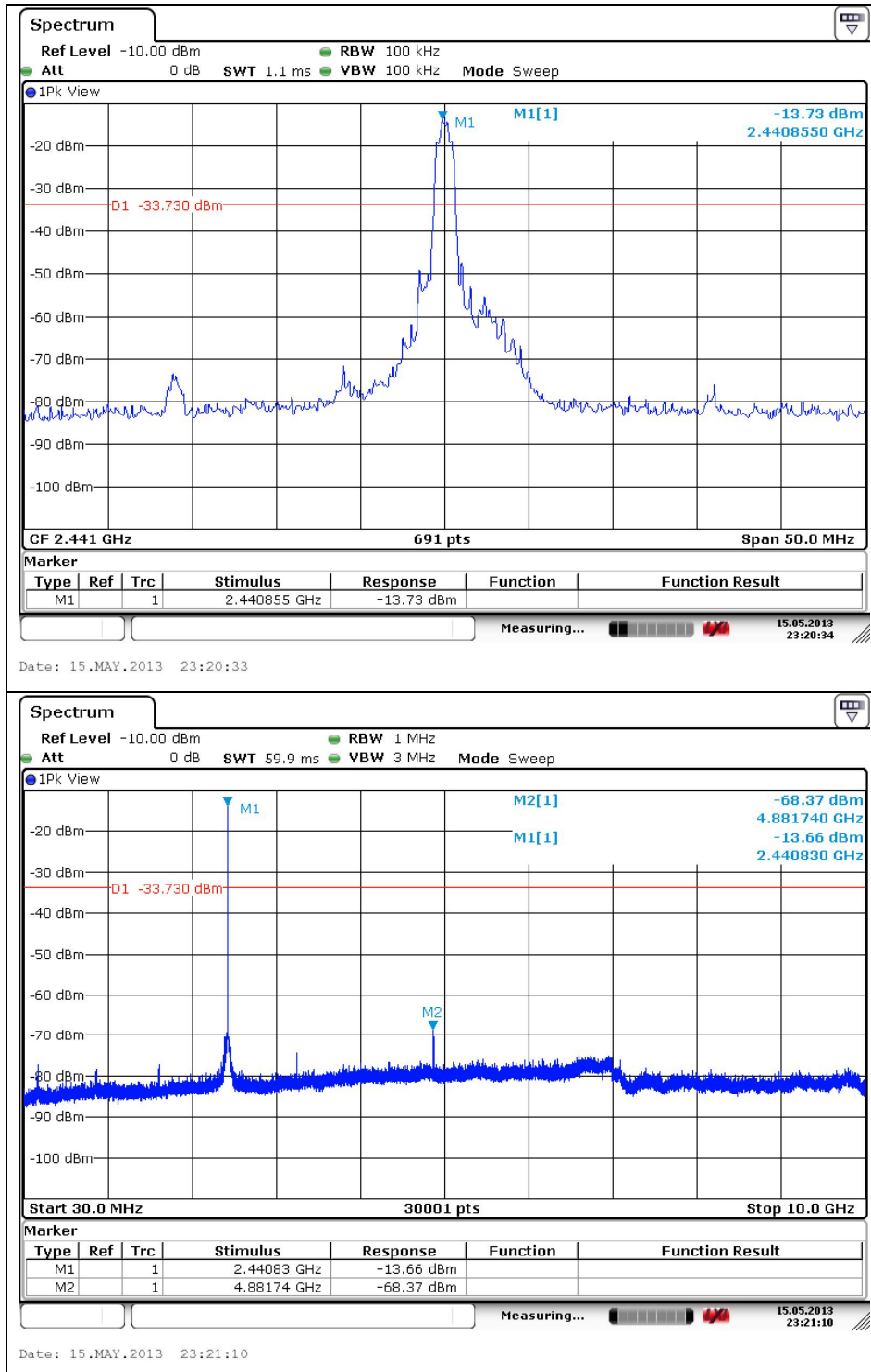

The results shown in this test report refer only to the sample(s) tested unless otherwise stated. This test report cannot be reproduced, except in full, without prior written permission of the Company.

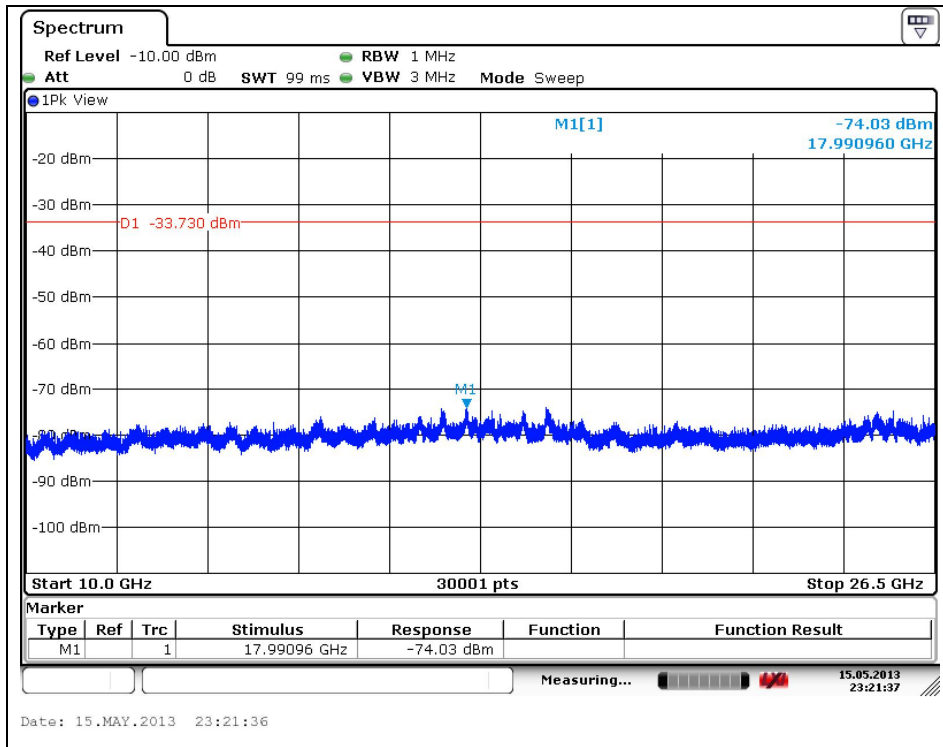

Note:

Offset (dB) = Directional Coupler(dB) + Cable loss (dB)

Final Result (dB m) = Reading values (dB m) + Spurious offset (dB)

Frequency (MHz)	Reading values (dB m)	Spurious offset (dB)	Final Result (dB m)
4 881.74	-68.37	17.59	-50.78
17 990.96	Noise floor	-	-

The results shown in this test report refer only to the sample(s) tested unless otherwise stated. This test report cannot be reproduced, except in full, without prior written permission of the Company.

High Channel

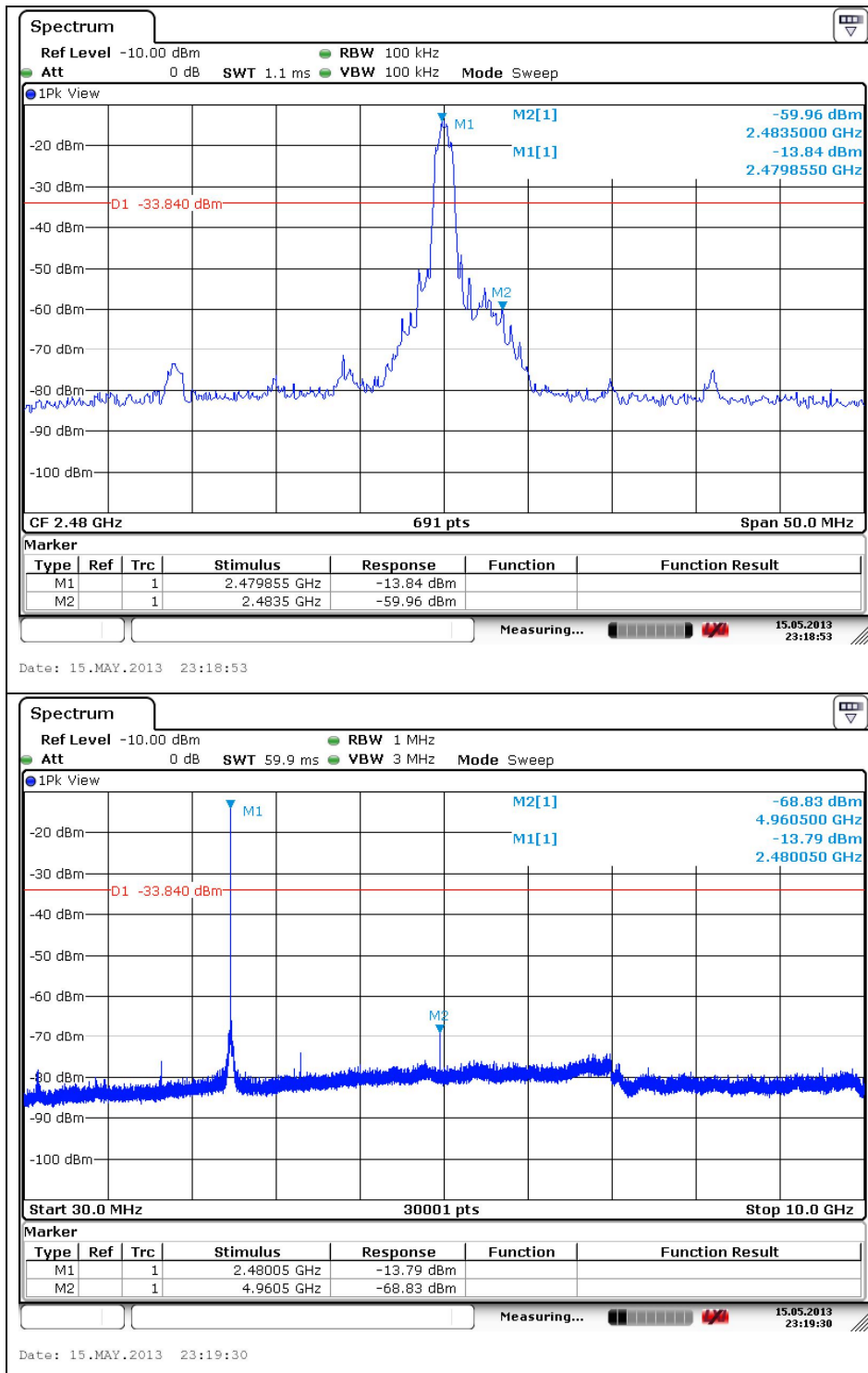

The results shown in this test report refer only to the sample(s) tested unless otherwise stated. This test report cannot be reproduced, except in full, without prior written permission of the Company.

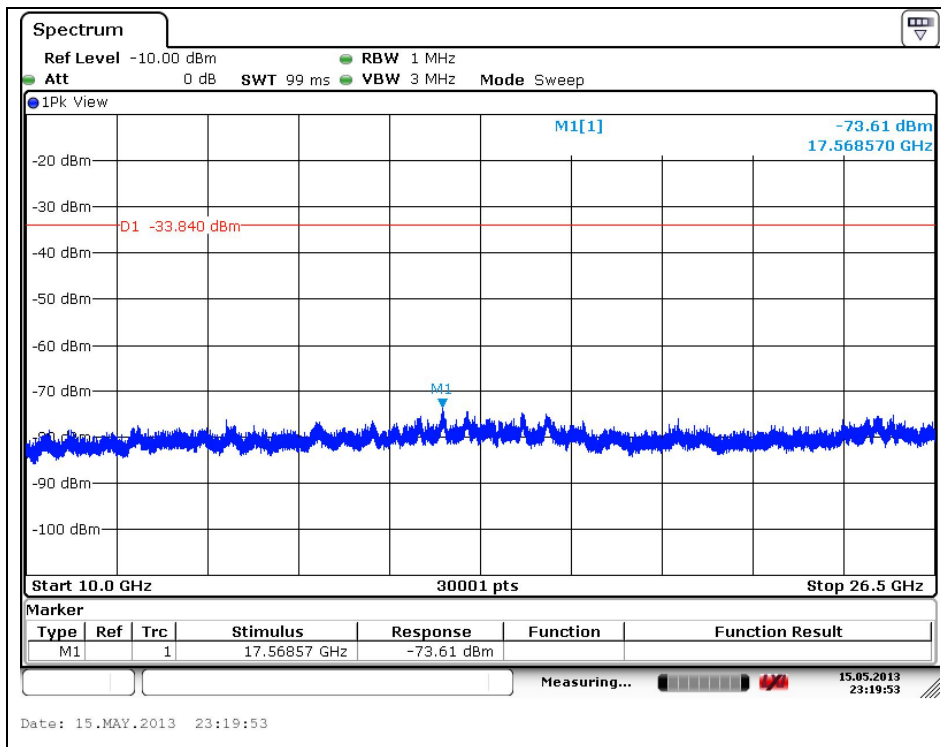

Note:

Offset (dB) = Directional Coupler(dB) + Cable loss (dB)

Final Result (dB m) = Reading values (dB m) + Spurious offset (dB)

Frequency (MHz)	Reading values (dB m)	Spurious offset (dB)	Final Result (dB m)
2 483.50	-59.96	16.94	-43.02
4 960.50	-68.83	17.91	-50.92
17 568.57	Noise floor	-	-

The results shown in this test report refer only to the sample(s) tested unless otherwise stated. This test report cannot be reproduced, except in full, without prior written permission of the Company.

Band edge at Hopping

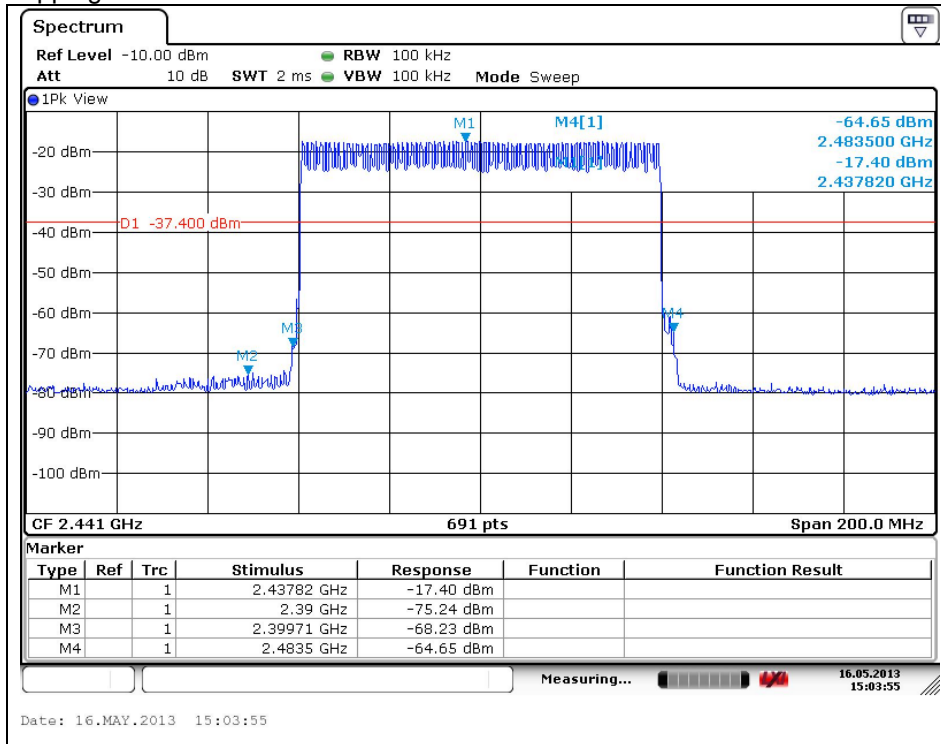

Note:

Offset (dB) = Directional Coupler(dB) + Cable loss (dB)

Final Result (dB m) = Reading values (dB m) + Spurious offset (dB)

Frequency (MHz)	Reading values (dB m)	Spurious offset (dB)	Final Result (dB m)
2 390.00	-75.24	16.92	-58.32
2 399.71	-68.23	16.99	-51.24
2 483.50	-64.65	16.94	-47.71

The results shown in this test report refer only to the sample(s) tested unless otherwise stated. This test report cannot be reproduced, except in full, without prior written permission of the Company.

3. 20 dB Bandwidth Measurement and 99 % BW

3.1. Test Setup

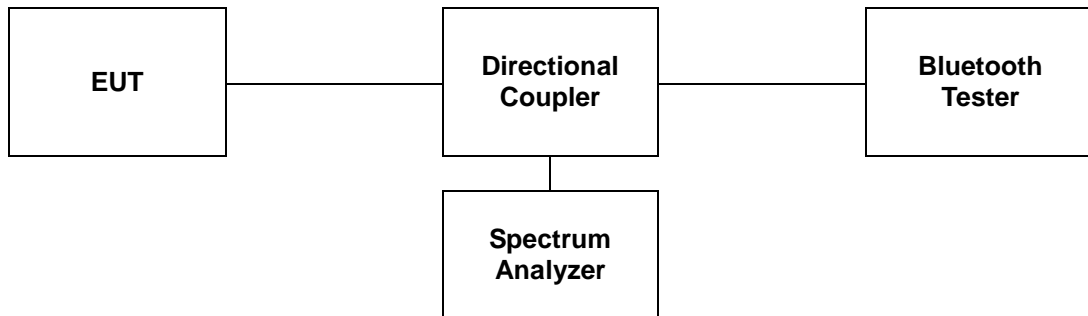

3.2. Limit

Limit: Not Applicable

3.3. Test Procedure

3.3.1. 20 dB Bandwidth

All data rates and modes were investigated for this test. The full data for the worst case data rate are reported in this section.

The test follows DA000705

The 20 dB band width was measured with a spectrum analyzer connected to RF antenna connector (conducted measurement) while EUT was operating in transmit mode at the appropriate center frequency.

Use the following spectrum analyzer setting :

Span = approximately 2 to 3 times the 20 dB bandwidth, centered on a hopping channel.

RBW = greater than 1 % of the 20 dB bandwidth

VBW = RBW

Sweep = auto

Detector = peak

Trace = max hold

The marker-to-peak function to set the mark to the peak of the emission. Use the marker-delta function to measure 20 dB down one side of the emission. Reset the function, and move the marker to the other side of the emission, until it is (as close as possible to) even with the reference marker level. The marker-delta reading at this point is 20 dB bandwidth of the emission.

3.3.2. 99% Bandwidth

Set the spectrum analyzer as SPAN = 2 or 3 times necessary bandwidth, RBW = approximately 1 % of the SPAN, VBW is set to 3 times RBW, Detector = sampling, Trace mode = max hold.

Measure lowest and highest frequencies are placed in a running sum until 0.5 % and 99.5 % of the total is reached.

Record the SPAN between the lowest and the highest frequencies for the 99 % occupied bandwidth.

Repeat until all the test channels are investigated.

The results shown in this test report refer only to the sample(s) tested unless otherwise stated. This test report cannot be reproduced, except in full, without prior written permission of the Company.

3.4. Test Results

Ambient temperature : (23 ± 2) °C

Relative humidity : 47 % R.H.

Operation Mode	Data Rate	Channel	Channel Frequency (MHz)	20 dB Bandwidth(MHz)	99 % Bandwidth(MHz)
GFSK	1 Mbps	Low	2 402	0.890	0.855
		Middle	2 441	0.886	0.860
		High	2 480	0.890	0.860
π/4DQPSK	2 Mbps	Low	2 402	1.220	1.164
		Middle	2 441	1.220	1.159
		High	2 480	1.216	1.164
8DPSK	3 Mbps	Low	2 402	1.216	1.142
		Middle	2 441	1.216	1.142
		High	2 480	1.216	1.142

The results shown in this test report refer only to the sample(s) tested unless otherwise stated. This test report cannot be reproduced, except in full, without prior written permission of the Company.

SGS Korea Co., Ltd. (Gunpo Laboratory) 18-34, Sanbon-dong, Gunpo-si, Gyeonggi-do, Korea, 435-040

Tel. +82 31 428 5700 / Fax. +82 31 427 2371

www.ee.sgs.com/korea

20 dB Bandwidth
Operating Mode: GFSK
 Low Channel

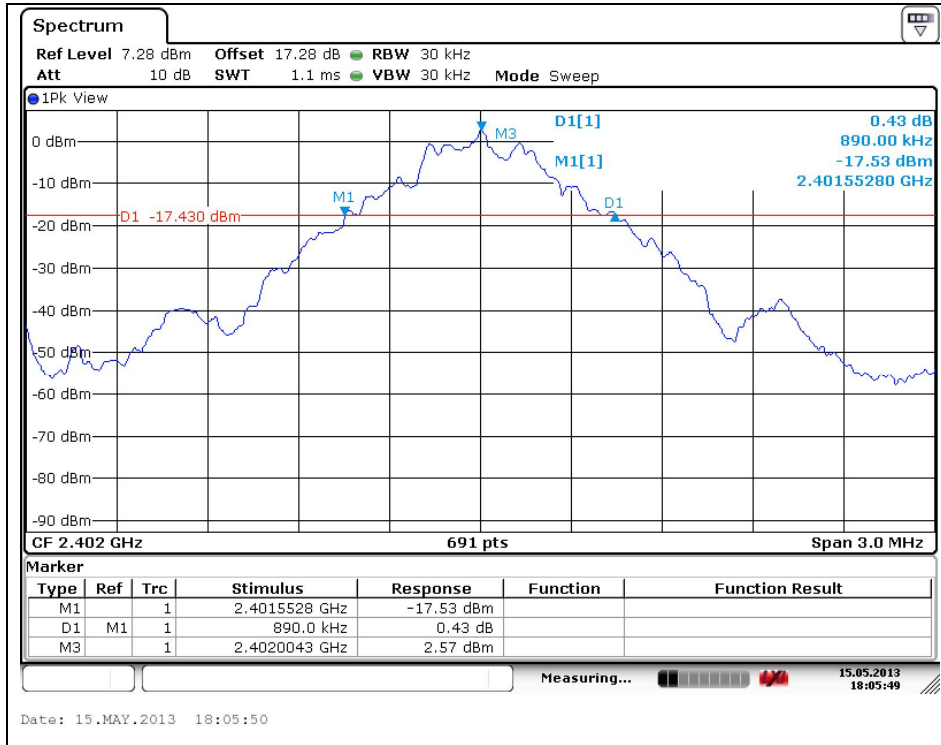

Middle Channel

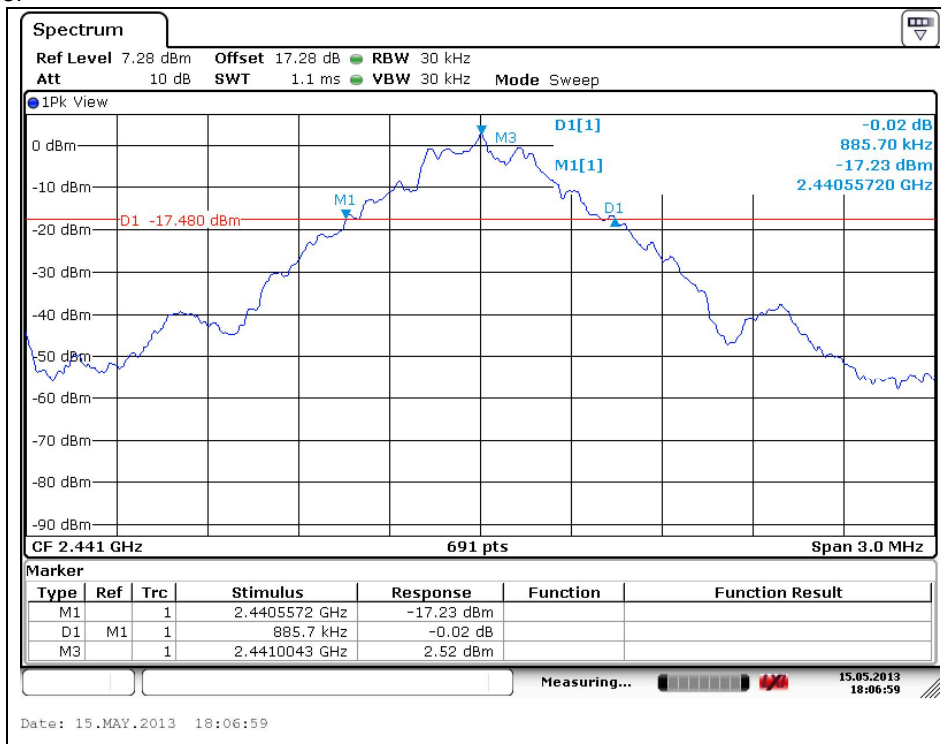

The results shown in this test report refer only to the sample(s) tested unless otherwise stated. This test report cannot be reproduced, except in full, without prior written permission of the Company.