

# PDP MONITOR (HPN6339) BLOCK DIAGRAM

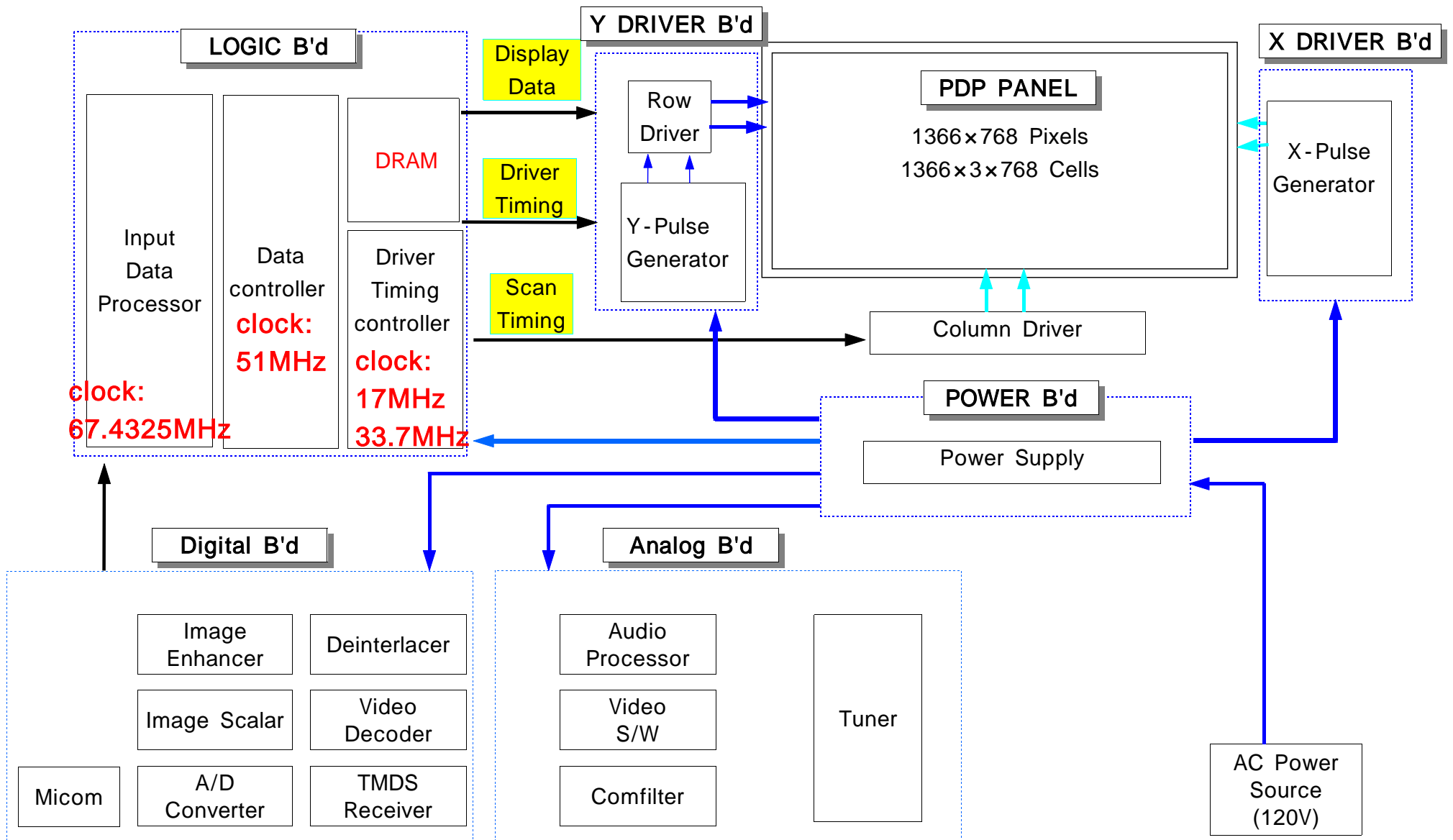

# HPN6339 Y Driver B'd Block Diagram

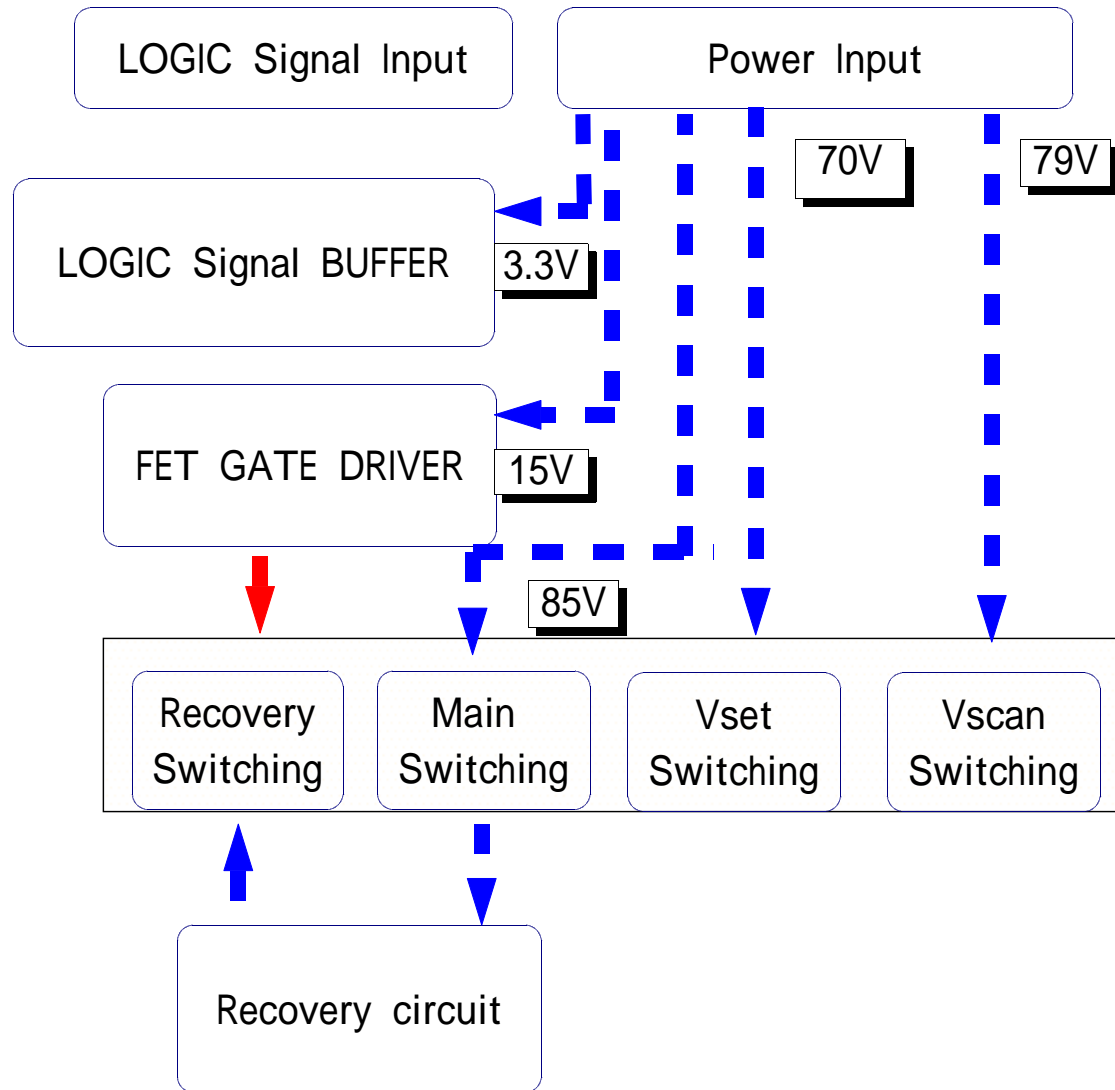

# HPN6339 X Driver B'd Block Diagram

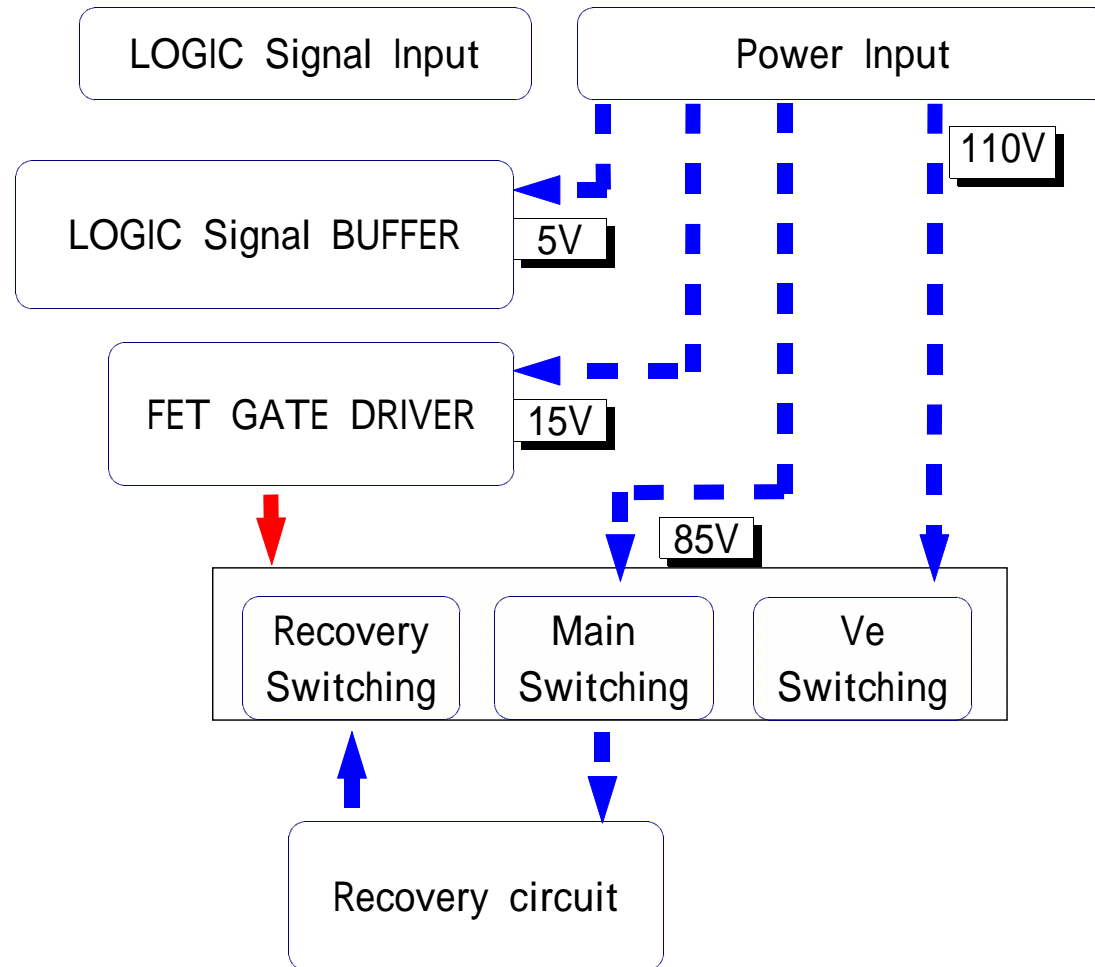

- CRYSTAL
- DIGITAL SIGNAL
- CLOCK(67.4325 MHz)
- CLOCK(51.0 MHz)
- CLOCK(33.7 MHz)
- CLOCK(17.0 MHz)

**1F3A IC**

2002.02.05

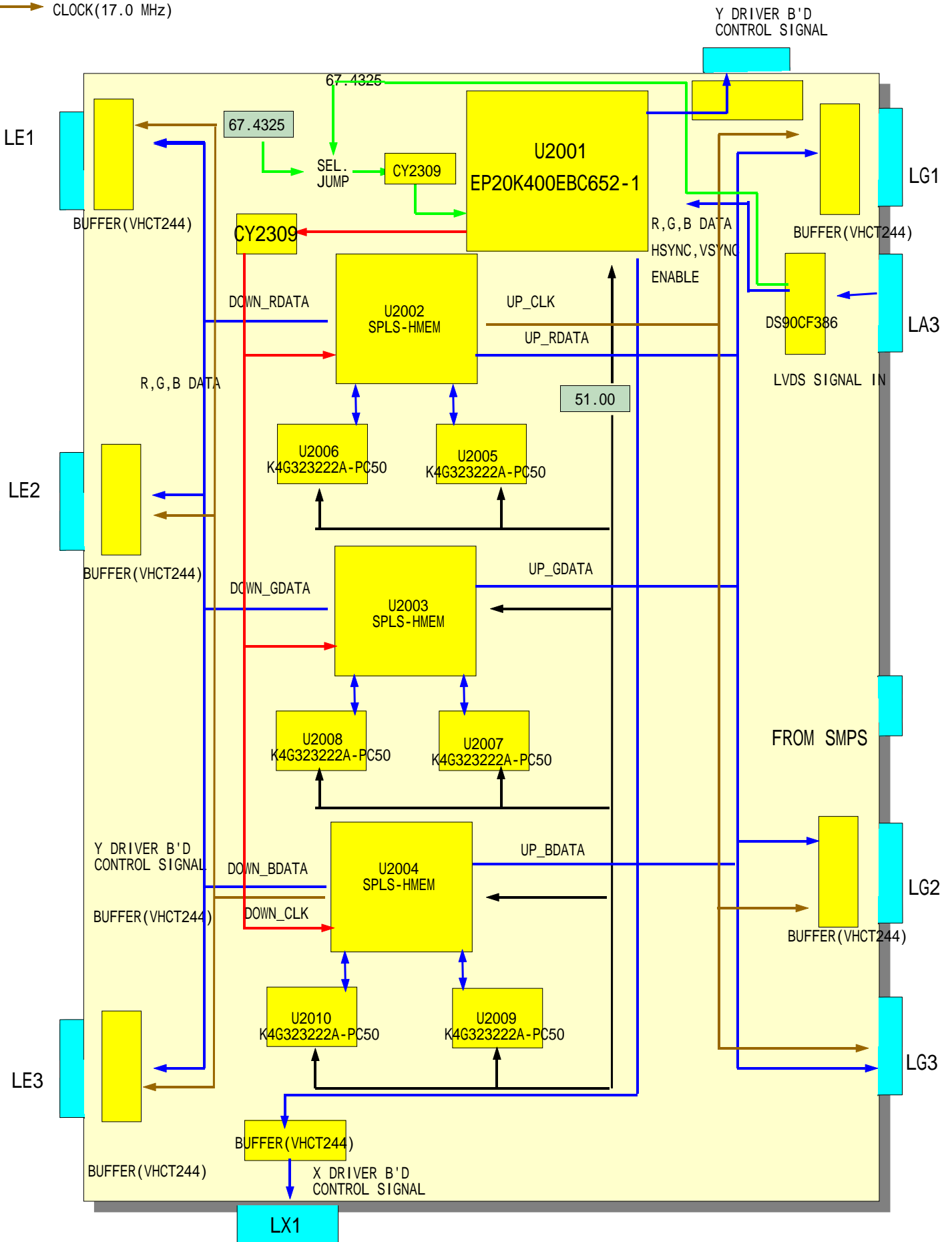

# HPN6339 SMPS Block Diagram

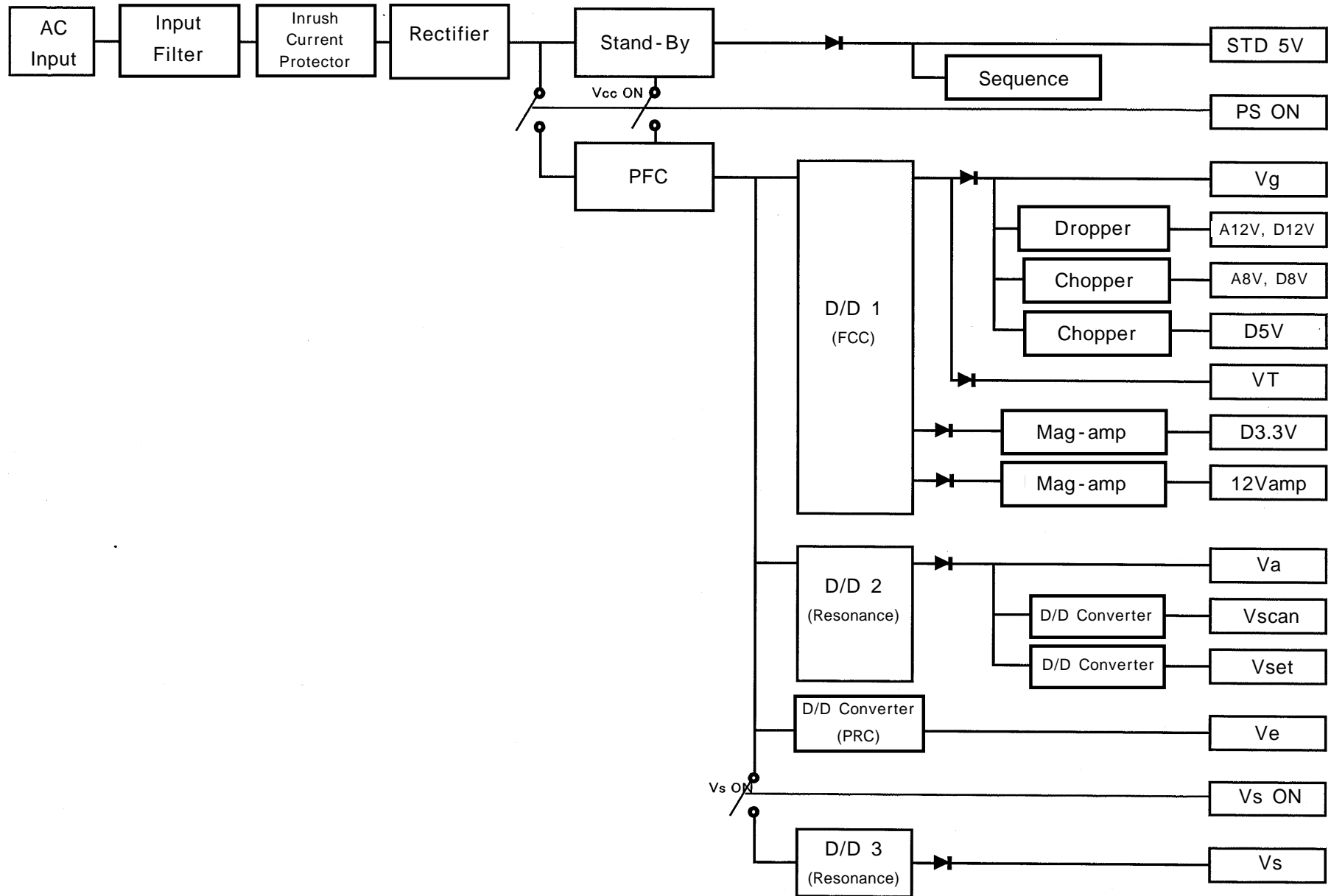



## 2. ANALOG BOARD IC & SIGNAL BLOCK DIAGRAM

CRYSTAL  
  ANALOG Signal  
  DIGITAL Signal  
  CLOCK Signal

