



RADIO TEST REPORT

Test Report No. : 33IE0012-HO-A

Applicant : SAMSUNG ELECTRONICS CO., LTD.
Type of Equipment : GSM/GPRS 850/1900 and WCDMA1900 Phone with BT v4.0(LE), 802.11b/g/n
Model No. : GT-S6810E
FCC ID : A3LGTS6810E
Test regulation : FCC Part 15 Subpart C: 2012
Test Result : Complied

1. This test report shall not be reproduced in full or partial, without the written approval of UL Japan, Inc.
2. The results in this report apply only to the sample tested.
3. This sample tested is in compliance with the above regulation.
4. The test results in this report are traceable to the national or international standards.
5. This test report must not be used by the customer to claim product certification, approval, or endorsement by NVLAP, NIST, or any agency of the Federal Government.

Date of test: April 16 to May 1, 2013

Representative test engineer:

Hironobu Ohnishi
Engineer of WiSE Japan,
UL Verification Service

Approved by:

Takahiro Hatakeda
Leader of WiSE Japan,
UL Verification Service



NVLAP LAB CODE: 200572-0

This laboratory is accredited by the NVLAP LAB CODE 200572-0, U.S.A. The tests reported herein have been performed in accordance with its terms of accreditation. *As for the range of Accreditation in NVLAP, you may refer to the WEB address, <http://www.ul.com/japan/jpn/pages/services/emc/about/mark1/index.jsp#nvlap>

UL Japan, Inc.

Head Office EMC Lab.

4383-326 Asama-cho, Ise-shi, Mie-ken 516-0021 JAPAN

Telephone : +81 596 24 8999

Facsimile : +81 596 24 8124

13-EM-F0429

CONTENTS	PAGE
SECTION 1: Customer information.....	4
SECTION 2: Equipment under test (E.U.T.).....	4
SECTION 3: Test specification, procedures & results.....	6
SECTION 4: Operation of E.U.T. during testing	9
SECTION 5: Conducted Emission.....	12
SECTION 6: Radiated Spurious Emission	13
SECTION 7: Antenna Terminal Conducted Tests.....	14
APPENDIX 1: Data of EMI test.....	15
Conducted Emission	15
6dB Bandwidth	18
Maximum Peak Output Power	22
Radiated Spurious Emission	28
Duty rate confirmation	38
Conducted Spurious Emission	40
Power Density	43
99% Occupied Bandwidth	48
APPENDIX 2: Test instruments	51
APPENDIX 3: Photographs of test setup	52
Conducted Emission	52
Radiated Spurious Emission	53
Worst Case Position (Horizontal: Z-axis/ Vertical: Z-axis).....	54

UL Japan, Inc.

Head Office EMC Lab.

4383-326 Asama-cho, Ise-shi, Mie-ken 516-0021 JAPAN

Telephone : +81 596 24 8999

Facsimile : +81 596 24 8124

SECTION 1: Customer information

Company Name : SAMSUNG ELECTRONICS CO., LTD.
Address : 416, MAETAN 3-DONG, YEONGTONG-GU SUWON-CITY,
GYEONGGI-DO 443-742, SOUTH KOREA

SECTION 2: Equipment under test (E.U.T.)

2.1 Identification of E.U.T.

Type of Equipment : GSM/GPRS 850/1900 and WCDMA1900 Phone with
BT v4.0(LE), 802.11b/g/n
Model No. : GT-S6810E
Serial No. : Refer to Section 4, Clause 4.2
Rating : AC100-240V/50-60Hz (AC Adapter)
DC3.7V/1200mAh (Battery)
Receipt Date of Sample : April 15, 2013
Modification of EUT : No Modification by the test lab

UL Japan, Inc.

Head Office EMC Lab.

4383-326 Asama-cho, Ise-shi, Mie-ken 516-0021 JAPAN

Telephone : +81 596 24 8999

Facsimile : +81 596 24 8124

2.2 Product Description

Radio Specification

Bluetooth (BDR/EDR)

Equipment Type	Transceiver
Frequency of Operation	2402-2480MHz
Type of Modulation	FHSS
Bandwidth & Channel spacing	1MHz & 1MHz
Antenna Type	FPCB Antenna
Antenna Gain	-1.41dBi

Bluetooth (Low Energy)

Equipment Type	Transceiver
Frequency of Operation	2402-2480MHz
Type of Modulation	DSSS, FHSS
Bandwidth & Channel spacing	1MHz & 2MHz
Antenna Type	FPCB Antenna
Antenna Gain	-1.41dBi

WLAN (IEEE802.11b/g/n-20)

Equipment Type	Transceiver
Frequency of Operation	2412-2462MHz
Type of Modulation	DSSS, OFDM
Bandwidth & Channel spacing	20MHz & 5MHz
Antenna Type	FPCB Antenna
Antenna Gain	-1.41dBi

GSM

Equipment Type	Transceiver
Frequency of Operation	[Up Link] GSM850: 824 – 849MHz PCS: 1850 – 1910MHz [Down Link] GSM850: 869 – 894MHz PCS: 1930 – 1990MHz
Type of Modulation	GMSK
Emission Designator	GSM850: 250KGXW PCS: 250KGXW
Antenna Type	MID/PIFA internal Antenna
Antenna Gain	GSM850: -2.3dBi PCS: -2.3dBi

W-CDMA

Equipment Type	Transceiver
Frequency of Operation	[Up Link] Band II: 1850 – 1910MHz [Down Link] Band II: 1930 – 1990MHz
Type of Modulation	QPSK
Emission Designator	Band II: 4M15F9W
Antenna Type	MID/PIFA internal Antenna
Antenna Gain	Band II: -2.3dBi

UL Japan, Inc.

Head Office EMC Lab.

4383-326 Asama-cho, Ise-shi, Mie-ken 516-0021 JAPAN

Telephone : +81 596 24 8999

Facsimile : +81 596 24 8124

SECTION 3: Test specification, procedures & results

3.1 Test Specification

Test Specification : FCC Part 15 Subpart C: 2012, final revised on December 27, 2012 and effective January 28, 2013

Title : FCC 47CFR Part15 Radio Frequency Device Subpart C Intentional Radiators
Section 15.207 Conducted limits
Section 15.247 Operation within the bands 902-928MHz,
2400-2483.5MHz, and 5725-5850MHz

3.2 Procedures and results

Item	Test Procedure	Specification	Worst margin	Results	Remarks
Conducted Emission	FCC: ANSI C63.4:2003 7. AC powerline Conducted Emission measurements ----- IC: RSS-Gen 7.2.4	FCC: Section 15.207 ----- IC: RSS-Gen 7.2.4	[WLAN] QP 13.9dB, 20.19017MHz, L AV 19.2dB, 0.32932MHz, N [BT LE] QP 14.4dB, 20.20010MHz, L AV 15.4dB, 0.33180MHz, N	Complied	-
6dB Bandwidth	FCC: "Guidance for Performing Compliance Measurements on Digital Transmission Systems (DTS) Operating Under §15.247(issued on October 4, 2012)" ----- IC: RSS-Gen 4.6.2	FCC: Section 15.247(a)(2) ----- IC: RSS-210 A8.2(a)	See data.	Complied	Conducted
Maximum Peak Output Power	FCC: "Guidance for Performing Compliance Measurements on Digital Transmission Systems (DTS) Operating Under §15.247(issued on October 4, 2012)" ----- IC: RSS-Gen 4.8	FCC: Section 15.247(b)(3) ----- IC: RSS-210 A8.4(4)		Complied	Conducted
Power Density	FCC: "Guidance for Performing Compliance Measurements on Digital Transmission Systems (DTS) Operating Under §15.247(issued on October 4, 2012)" ----- IC: -	FCC: Section 15.247 (e) ----- IC: RSS-210 A8.2(b)		Complied	Conducted
Spurious Emission Restricted Band Edges	FCC: "Guidance for Performing Compliance Measurements on Digital Transmission Systems (DTS) Operating Under §15.247(issued on October 4, 2012)" ----- IC: RSS-Gen 4.9	FCC: Section15.247(d) ----- IC: RSS-210 A8.5 RSS-Gen 7.2.3		[WLAN] 8.5dB, 9648.000MHz, AV, Vertical [BT LE] 7.8dB, 9920.000MHz, AV, Horizontal/ 9920.000MHz, AV, Vertical	Complied

Note: UL Japan, Inc.'s EMI Work Procedures No. 13-EM-W0420 and 13-EM-W0422.

* In case any questions arise about test procedure, ANSI C63.4: 2003 is also referred.

UL Japan, Inc.

Head Office EMC Lab.

4383-326 Asama-cho, Ise-shi, Mie-ken 516-0021 JAPAN

Telephone : +81 596 24 8999

Facsimile : +81 596 24 8124

3.3 Addition to standard

Item	Test Procedure	Specification	Worst margin	Results	Remarks
99% Occupied Bandwidth	IC: RSS-Gen 4.6.1	IC: RSS-Gen 4.6.1	N/A	-	Conducted

Other than above, no addition, exclusion nor deviation has been made from the standard.

3.4 Uncertainty

EMI

The following uncertainties have been calculated to provide a confidence level of 95% using a coverage factor k=2.

Test room (semi-anechoic chamber)	Conducted emission (+dB)
	150kHz-30MHz
No.1	3.5dB
No.2	3.6dB
No.3	3.6dB
No.4	3.6dB

Test room (semi-anechoic chamber)	Radiated emission						
	(3m*)(+dB)				(1m*)(+dB)		(0.5m*)(+dB)
	9kHz -30MHz	30MHz -300MHz	300MHz -1GHz	1GHz -10GHz	10GHz -18GHz	18GHz -26.5GHz	26.5GHz -40GHz
No.1	4.3dB	5.0dB	5.1dB	4.9dB	5.8dB	4.4dB	4.3dB
No.2	4.3dB	5.2dB	5.1dB	5.0dB	5.7dB	4.3dB	4.2dB
No.3	4.6dB	5.0dB	5.1dB	5.0dB	5.7dB	4.5dB	4.2dB
No.4	4.8dB	5.2dB	5.0dB	5.0dB	5.7dB	5.2dB	4.2dB

*3m/1m/0.5m = Measurement distance

Power meter (+dB)	
Below 1GHz	Above 1GHz
0.7dB	1.5dB

Antenna terminal conducted emission and Power density (+dB)			Antenna terminal conducted emission (+dB)		Channel power (+dB)
Below 1GHz	1GHz-3GHz	3GHz-18GHz	18GHz-26.5GHz	26.5GHz-40GHz	
1.5dB	1.7dB	2.8dB	2.8dB	2.9dB	2.6dB

Conducted Emission test

[WLAN] The data listed in this test report has enough margin, more than the site margin.

[BT LE] The data listed in this test report has enough margin, more than the site margin.

Radiated emission test(3m)

[WLAN] The data listed in this test report has enough margin, more than the site margin.

[BT LE] The data listed in this test report has enough margin, more than the site margin.

UL Japan, Inc.

Head Office EMC Lab.

4383-326 Asama-cho, Ise-shi, Mie-ken 516-0021 JAPAN

Telephone : +81 596 24 8999

Facsimile : +81 596 24 8124

3.5 Test Location

UL Japan, Inc. Head Office EMC Lab. *NVLAP Lab. code: 200572-0
4383-326 Asama-cho, Ise-shi, Mie-ken 516-0021 JAPAN
Telephone : +81 596 24 8999 Facsimile : +81 596 24 8124

	FCC Registration Number	IC Registration Number	Width x Depth x Height (m)	Size of reference ground plane (m) / horizontal conducting plane	Other rooms
No.1 semi-anechoic chamber	313583	2973C-1	19.2 x 11.2 x 7.7m	7.0 x 6.0m	No.1 Power source room
No.2 semi-anechoic chamber	655103	2973C-2	7.5 x 5.8 x 5.2m	4.0 x 4.0m	-
No.3 semi-anechoic chamber	148738	2973C-3	12.0 x 8.5 x 5.9m	6.8 x 5.75m	No.3 Preparation room
No.3 shielded room	-	-	4.0 x 6.0 x 2.7m	N/A	-
No.4 semi-anechoic chamber	134570	2973C-4	12.0 x 8.5 x 5.9m	6.8 x 5.75m	No.4 Preparation room
No.4 shielded room	-	-	4.0 x 6.0 x 2.7m	N/A	-
No.5 semi-anechoic chamber	-	-	6.0 x 6.0 x 3.9m	6.0 x 6.0m	-
No.6 shielded room	-	-	4.0 x 4.5 x 2.7m	4.75 x 5.4 m	-
No.6 measurement room	-	-	4.75 x 5.4 x 3.0m	4.75 x 4.15 m	-
No.7 shielded room	-	-	4.7 x 7.5 x 2.7m	4.7 x 7.5m	-
No.8 measurement room	-	-	3.1 x 5.0 x 2.7m	N/A	-
No.9 measurement room	-	-	8.0 x 4.5 x 2.8m	2.0 x 2.0m	-
No.10 measurement room	-	-	2.6 x 2.8 x 2.5m	2.4 x 2.4m	-
No.11 measurement room	-	-	3.1 x 3.4 x 3.0m	2.4 x 3.4m	-

* Size of vertical conducting plane (for Conducted Emission test) : 2.0 x 2.0m for No.1, No.2, No.3, and No.4 semi-anechoic chambers and No.3 and No.4 shielded rooms.

3.6 Data of EMI, Test instruments, and Test set up

Refer to APPENDIX.

UL Japan, Inc.

Head Office EMC Lab.

4383-326 Asama-cho, Ise-shi, Mie-ken 516-0021 JAPAN

Telephone : +81 596 24 8999

Facsimile : +81 596 24 8124

SECTION 4: Operation of E.U.T. during testing

4.1 Operating Mode(s)

Test operating mode was determined as follows according to “Section 1 of 6 802.11 a/b/g/n testing - Managing Complex Regulatory Approvals - ” of TCB Council Workshop October 2009.

Mode	Remarks*
IEEE 802.11b (11b)	11Mbps, PN9
IEEE 802.11g (11g)	9Mbps, PN9
IEEE 802.11n SISO 20MHz BW (11n-20)	MCS 5, PN9
Bluetooth(BT) LE(Low Energy)	Maximum Packet Size, PN9
*The worst condition was determined based on the test result of Maximum Peak Output Power (Mid Channel).	

Power of the EUT was set by the software as follows:

H/W version: REV1.0
S/W version: S6810E.010

[Power Setting]

11b: 14 dBm

11g: 12 dBm

11n-20: 11 dBm

BT LE: Maximum power of the EUT was transmitted on Bluetooth testing mode.

*The above setting of the software is the worst case.

Any conditions under the normal use do not exceed the condition of setting.

In addition, end users cannot change the settings of the output power of the product.

UL Japan, Inc.

Head Office EMC Lab.

4383-326 Asama-cho, Ise-shi, Mie-ken 516-0021 JAPAN

Telephone : +81 596 24 8999

Facsimile : +81 596 24 8124

*Details of Operating mode(s) for WLAN

Test Item	Operating Mode	Tested frequency
Conducted Emission, Spurious Emission (Conducted)	11g Tx *1)	2412MHz
6dB Bandwidth, Maximum Peak Output Power, Power Density, 99% Occupied Bandwidth	11b Tx 11g Tx 11n-20 Tx	2412MHz 2437MHz 2462MHz
Spurious Emission (Radiated)	11b Tx 11g Tx *2)	2412MHz 2437MHz 2462MHz
Band Edge Compliance (Radiated)	11b Tx 11g Tx 11n-20 Tx	2412MHz 2462MHz

*1) The mode was tested as a representative, because it had the highest power at antenna terminal test.
*2) Since 11g and 11n-20 have the same modulation method and no differences in transmitting specification, test was performed on the representative mode that had the highest peak output power.

*Details of Operating mode(s) for BT LE

Test Item	Operating Mode	Tested frequency
Conducted Emission, 6dB Bandwidth, Maximum Peak Output Power, Spurious Emission, Power Density, 99% Occupied Bandwidth	BT LE	2402MHz 2440MHz 2480MHz

UL Japan, Inc.

Head Office EMC Lab.

4383-326 Asama-cho, Ise-shi, Mie-ken 516-0021 JAPAN

Telephone : +81 596 24 8999

Facsimile : +81 596 24 8124

4.2 Configuration and peripherals

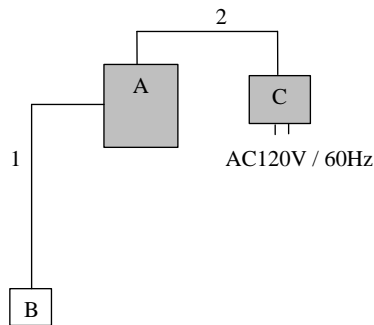

* Cabling and setup(s) were taken into consideration and test data was taken under worse case conditions.

Description of EUT and Support equipment

No.	Item	Model number	Serial number	Manufacturer	Remarks
A	GSM/GPRS 850/1900 and WCDMA1900 Phone with BT v4.0(LE), 802.11b/g/n	GT-S6810E	FK-095-D *1) FK-095-B *2)	SAMSUNG	EUT
B	Ear phone	-	-	SAMSUNG	-
C	AC Adaptor	ETAOU10EBE	DK2CB19TS/7-E	SAMSUNG	EUT

*1) Used for Antenna Terminal conducted test

*2) Used for Conducted Emission and Radiated Emission tests

List of cables used

No.	Name	Length (m)	Shield		Remarks
			Cable	Connector	
1	Ear phone Cable	1.8	Shielded	Shielded	-
2	DC Cable	1.5	Unshielded	Unshielded	-

UL Japan, Inc.

Head Office EMC Lab.

4383-326 Asama-cho, Ise-shi, Mie-ken 516-0021 JAPAN

Telephone : +81 596 24 8999

Facsimile : +81 596 24 8124

SECTION 5: Conducted Emission

Test Procedure and conditions

EUT was placed on a urethane platform of nominal size, 0.5m by 1.0m, raised 0.8m above the conducting ground plane. The rear of tabletop was located 40cm to the vertical conducting plane. The rear of EUT, including peripherals aligned and flushed with rear of tabletop. All other surfaces of tabletop were at least 80cm from any other grounded conducting surface. EUT was located 80cm from a Line Impedance Stabilization Network (LISN)/ Artificial mains Network (AMN) and excess AC cable was bundled in center.

For the tests on EUT with other peripherals (as a whole system)

I/O cables that were connected to the peripherals were bundled in center. They were folded back and forth forming a bundle 30cm to 40cm long and were hanged at a 40cm height to the ground plane. All unused 50ohm connectors of the LISN(AMN) were resistivity terminated in 50ohm when not connected to the measuring equipment.

The AC Mains Terminal Continuous disturbance Voltage has been measured with the EUT in a Semi Anechoic Chamber. The EUT was connected to a LISN (AMN).

An overview sweep with peak detection has been performed.

The test results and limit are rounded off to one decimal place, so some differences might be observed.

Detector	: QP and CISPR AV
Measurement range	: 0.15-30MHz
Test data	: APPENDIX
Test result	: Pass

UL Japan, Inc.

Head Office EMC Lab.

4383-326 Asama-cho, Ise-shi, Mie-ken 516-0021 JAPAN

Telephone : +81 596 24 8999

Facsimile : +81 596 24 8124

SECTION 6: Radiated Spurious Emission

Test Procedure

It was measured based on "10.0 MAXIMUM UNWANTED EMISSION LEVELS" of "Guidance for Performing Compliance Measurements on Digital Transmission Systems (DTS) Operating Under §15.247 (Issued on October 4, 2012)".

EUT was placed on a urethane platform of nominal size, 0.5m by 1.0m, raised 0.8m above the conducting ground plane. The Radiated Electric Field Strength has been measured in a Semi Anechoic Chamber with a ground plane.

The height of the measuring antenna varied between 1 and 4m and EUT was rotated a full revolution in order to obtain the maximum value of the electric field strength.

The measurements were performed for both vertical and horizontal antenna polarization with the Test Receiver, or the Spectrum Analyzer.

The measurements were made with the following detector function of the test receiver and the Spectrum analyzer (in linear mode).

The test was made with the detector (RBW/VBW) in the following table.

When using Spectrum analyzer, the test was made with adjusting span to zero by using peak hold.

Test Antennas are used as below;

Frequency	30MHz to 300MHz	300MHz to 1GHz	Above 1GHz
Antenna Type	Biconical	Logperiodic	Horn

In any 100kHz bandwidth outside the restricted band in which the spread spectrum intentional radiator is operating, the radio frequency power that is produced by the intentional radiator confirmed 20dB below that in the 100kHz bandwidth within the band that contains the highest level of the desired power, based on a radiated measurement.

20dBc was applied to the frequency over the limit of FCC 15.209 / Table 5 of RSS-Gen 7.2.5(IC) and outside the restricted band of FCC15.205 / Table 3 of RSS-Gen 7.2.2 (IC).

Frequency	Below 1GHz	Above 1GHz		20dBc
Instrument used	Test Receiver	Spectrum Analyzer		Spectrum Analyzer
Detector	QP	PK	AV	PK
IF Bandwidth	BW 120kHz(T/R)	RBW: 1MHz VBW: 3MHz	Average Power Method: Alternative 1 *1) RBW: 1MHz VBW: 3MHz Trace: Free Run Detector: Power Averaging (RMS) Duty Factor was added to the results.	RBW: 100kHz VBW: 300kHz (S/A)
Test Distance	3m	3m (below 10GHz), 1m *2) (above 10GHz)		3m (below 10GHz), 1m *2) (above 10GHz)

*1) Average Power Measurement was performed based on 8.2.1 & 10.2.3.3 of "Guidance for Performing Compliance Measurements on Digital Transmission Systems (DTS) Operating Under §15.247 (Issued on October 4, 2012)"

*2) Distance Factor: $20 \times \log(3.0\text{m}/1.0\text{m}) = 9.5\text{dB}$

- The carrier level and noise levels were confirmed at each position of X, Y and Z axes of EUT to see the position of maximum noise, and the test was made at the position that has the maximum noise.

The test results and limit are rounded off to one decimal place, so some differences might be observed.

Measurement range : 30M-26.5GHz
Test data : APPENDIX
Test result : Pass

UL Japan, Inc.

Head Office EMC Lab.

4383-326 Asama-cho, Ise-shi, Mie-ken 516-0021 JAPAN

Telephone : +81 596 24 8999

Facsimile : +81 596 24 8124

SECTION 7: Antenna Terminal Conducted Tests

Test Procedure

The tests were made with below setting connected to the antenna port.

Test	Span	RBW	VBW	Sweep time	Detector	Trace	Instrument used
6dB Bandwidth	20MHz, 3MHz	100kHz	300kHz	Auto	Peak	Max Hold	Spectrum Analyzer
99% Occupied Bandwidth	Enough width to display 20dB Bandwidth	1 to 3% of Span	Three times of RBW	Auto	Peak	Max Hold	Spectrum Analyzer
Maximum Peak Output Power	-	-	-	Auto	Peak/ Average *1)	-	Power Meter (Option 3) (Sensor: 50MHz BW)
Peak Power Density	1.5 times the 6dB bandwidth	3kHz	9.1kHz	Auto	Peak	Max Hold	Spectrum Analyzer *2)
Conducted Spurious Emission	9kHz to 150kHz	200Hz	620Hz	Auto	Peak	Max Hold	Spectrum Analyzer
	150kHz to 30MHz	9.1kHz	27kHz				

*1) Reference data

*2) PSD Option 1 of "Guidance for Performing Compliance Measurements on Digital Transmission Systems (DTS) Operating Under §15.247 (Issued on October 4, 2012)".

The test results and limit are rounded off to two decimals place, so some differences might be observed.

Test data : **APPENDIX**
Test result : **Pass**

UL Japan, Inc.

Head Office EMC Lab.

4383-326 Asama-cho, Ise-shi, Mie-ken 516-0021 JAPAN

Telephone : +81 596 24 8999

Facsimile : +81 596 24 8124

APPENDIX 1: Data of EMI test

Conducted Emission

DATA OF CONDUCTED EMISSION TEST

UL Japan, Inc. Head Office EMC Lab. No.2 Semi Anechoic Chamber
Date : 2013/04/19

Report No. : 33IE0012-H0
Temp./Humi. : 22deg. C / 50% RH
Engineer : Hironobu Ohnishi

Mode / Remarks : Tx 11g 9Mbps 2412MHz

LIMIT : FCC15.207 QP
FCC15.207 AV

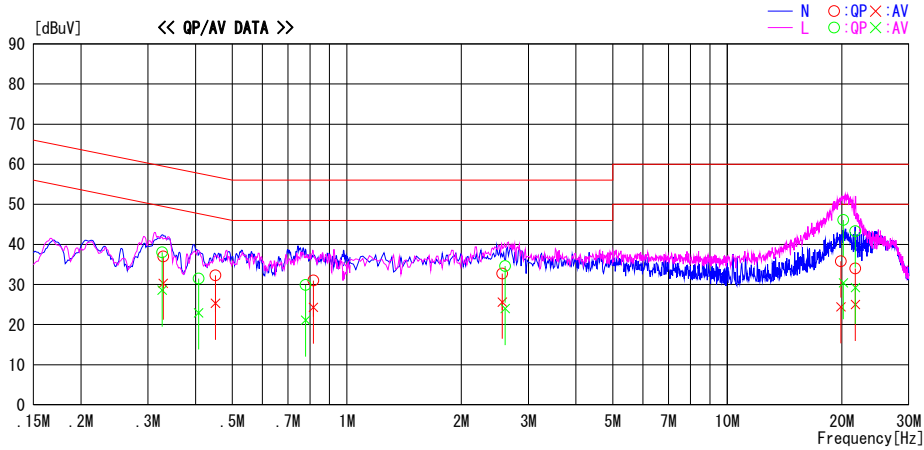

Frequency [MHz]	Reading Level		Corr. Factor [dB]	Results		Limit		Margin		Phase	Comment
	QP [dBuV]	AV [dBuV]		QP [dBuV]	AV [dBuV]	QP [dBuV]	AV [dBuV]	QP [dB]	AV [dB]		
0.32932	23.7	17.0	13.3	37.0	30.3	59.5	49.5	22.5	19.2	N	
0.45160	19.0	12.0	13.3	32.3	25.3	56.8	46.8	24.5	21.5	N	
0.81678	17.6	10.9	13.4	31.0	24.3	56.0	46.0	25.0	21.7	N	
2.56226	19.0	11.9	13.7	32.7	25.6	56.0	46.0	23.3	20.4	N	
19.90000	19.0	7.6	16.8	35.8	24.4	60.0	50.0	24.2	25.6	N	
21.71270	16.8	7.8	17.2	34.0	25.0	60.0	50.0	26.0	25.0	N	
0.32710	24.7	15.3	13.3	38.0	28.6	59.5	49.5	21.5	20.9	L	
0.40774	18.2	9.6	13.3	31.5	22.9	57.7	47.7	26.2	24.8	L	
0.77894	16.5	7.7	13.4	29.9	21.1	56.0	46.0	26.1	24.9	L	
2.60620	20.9	10.3	13.7	34.6	24.0	56.0	46.0	21.4	22.0	L	
20.19017	29.3	13.6	16.8	46.1	30.4	60.0	50.0	13.9	19.6	L	
21.71269	26.1	12.0	17.2	43.3	29.2	60.0	50.0	16.7	20.8	L	

CHART:WITH FACTOR,Peak hold data. CALCULATION:RESULT=READING+C.F(LISN LOSS+ATT LOSS +CABLE LOSS)
Except for the above table : adequate margin data below the limits.

*The limit is rounded down to one decimal place.

*The test result is rounded off to one or two decimal places, so some differences might be observed.

UL Japan, Inc.

Head Office EMC Lab.

4383-326 Asama-cho, Ise-shi, Mie-ken 516-0021 JAPAN

Telephone : +81 596 24 8999

Facsimile : +81 596 24 8124

Conducted Emission

DATA OF CONDUCTED EMISSION TEST

UL Japan, Inc. Head Office EMC Lab. No.2 Semi Anechoic Chamber
Date : 2013/04/19

Report No. : 33IE0012-H0
Temp./Humi. : 22deg. C / 50% RH
Engineer : Hironobu Ohnishi

Mode / Remarks : Tx Bluetooth Low Energy 2402MHz

LIMIT : FCC15.207 QP
FCC15.207 AV

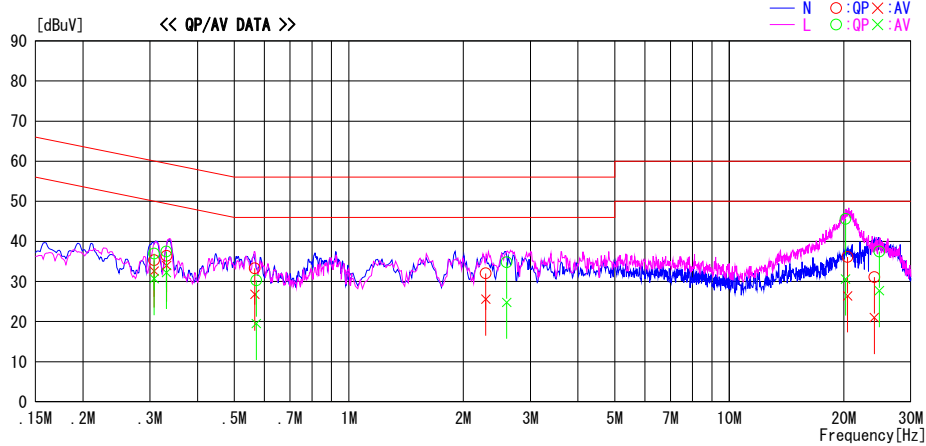

Frequency [MHz]	Reading Level		Corr. Factor [dB]	Results		Limit		Margin		Phase	Comment
	QP [dBuV]	AV [dBuV]		QP [dBuV]	AV [dBuV]	QP [dBuV]	AV [dBuV]	QP [dB]	AV [dB]		
0.30768	22.0	19.3	13.3	35.3	32.6	60.0	50.0	24.7	17.4	N	
0.33180	23.1	20.7	13.3	36.4	34.0	59.4	49.4	23.0	15.4	N	
0.56639	20.0	13.5	13.3	33.3	26.8	56.0	46.0	22.7	19.2	N	
2.29083	18.4	12.0	13.6	32.0	25.6	56.0	46.0	24.0	20.4	N	
20.46020	19.2	9.5	16.9	36.1	26.4	60.0	50.0	23.9	23.6	N	
24.04072	13.4	3.3	17.7	31.1	21.0	60.0	50.0	28.9	29.0	N	
0.30769	23.6	17.4	13.3	36.9	30.7	60.0	50.0	23.1	19.3	L	
0.33169	24.2	18.9	13.3	37.5	32.2	59.4	49.4	21.9	17.2	L	
0.57086	17.0	6.2	13.3	30.3	19.5	56.0	46.0	25.7	26.5	L	
2.59906	21.1	11.1	13.7	34.8	24.8	56.0	46.0	21.2	21.2	L	
20.20010	28.8	13.8	16.8	45.6	30.6	60.0	50.0	14.4	19.4	L	
24.81072	19.6	9.8	17.9	37.5	27.7	60.0	50.0	22.5	22.3	L	

CHART: WITH FACTOR, Peak hold data. CALCULATION: RESULT=READING+C.F(LIGN LOSS+ATT LOSS +CABLE LOSS)
Except for the above table : adequate margin data below the limits.

*The limit is rounded down to one decimal place.

*The test result is rounded off to one or two decimal places, so some differences might be observed.

UL Japan, Inc.

Head Office EMC Lab.

4383-326 Asama-cho, Ise-shi, Mie-ken 516-0021 JAPAN

Telephone : +81 596 24 8999

Facsimile : +81 596 24 8124

Conducted Emission

Test place	Head Office EMC Lab. No.2 Semi Anechoic Chamber
Report No.	33IE0012-HO
Date	04/18/2013
Temperature/ Humidity	22 deg. C / 50% RH
Engineer	Hironobu Ohnishi
Mode	Tx Bluetooth Low Energy

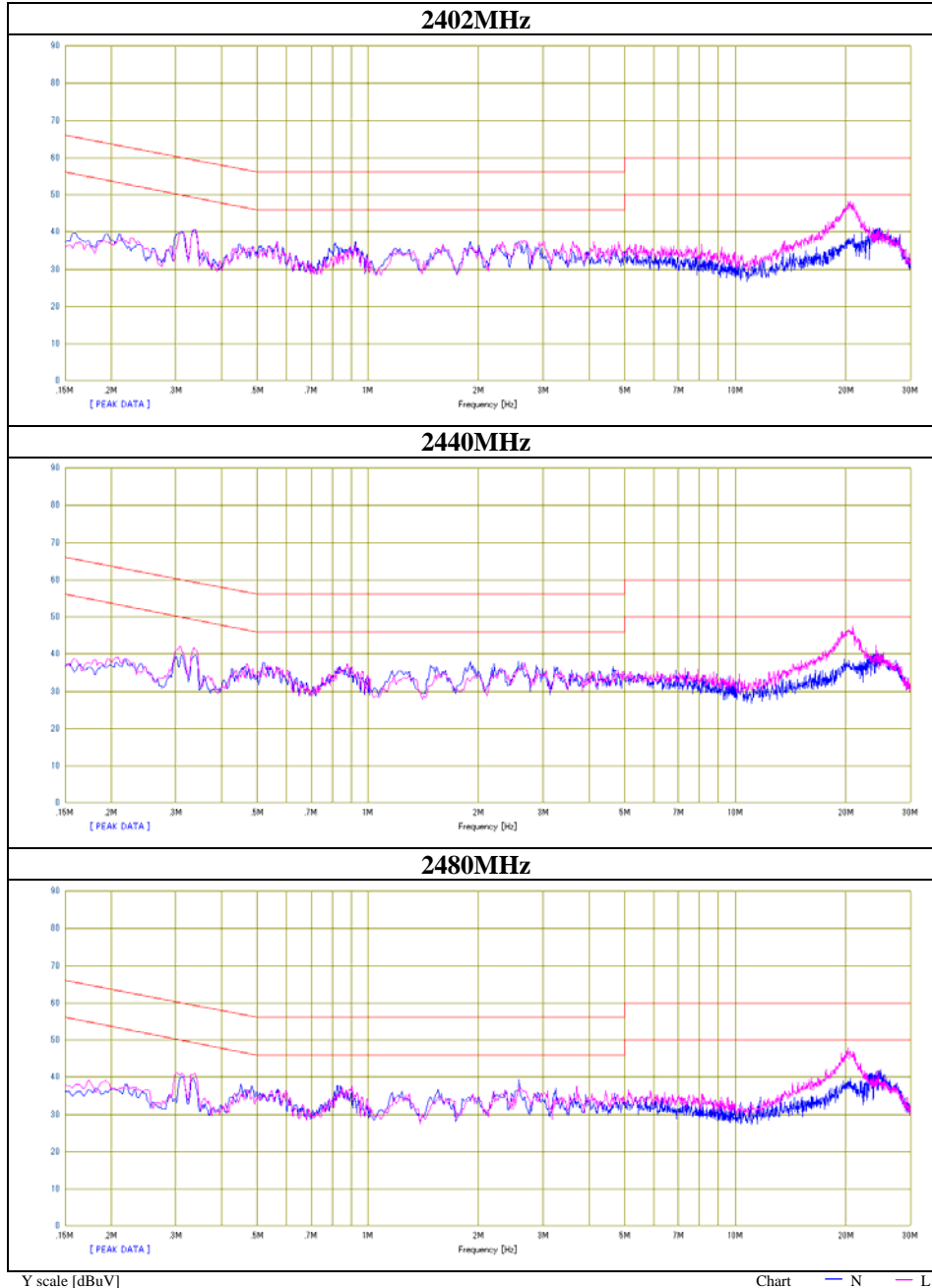

6dB Bandwidth

Test place Head Office EMC Lab. No.6 Measurement Room
Report No. 33IE0012-HO
Date 04/16/2013
Temperature/ Humidity 20deg. C / 40% RH
Engineer Yutaka Yoshida
Mode Tx WLAN

11b

Frequency [MHz]	6dB Bandwidth [MHz]	Limit [kHz]
2412	8.964	>500
2437	9.089	>500
2462	9.552	>500

11g

Frequency [MHz]	6dB Bandwidth [MHz]	Limit [kHz]
2412	15.155	>500
2437	15.119	>500
2462	15.068	>500

11n-20

Frequency [MHz]	6dB Bandwidth [MHz]	Limit [kHz]
2412	17.258	>500
2437	17.610	>500
2462	17.521	>500

UL Japan, Inc.

Head Office EMC Lab.

4383-326 Asama-cho, Ise-shi, Mie-ken 516-0021 JAPAN

Telephone : +81 596 24 8999

Facsimile : +81 596 24 8124

6dB Bandwidth

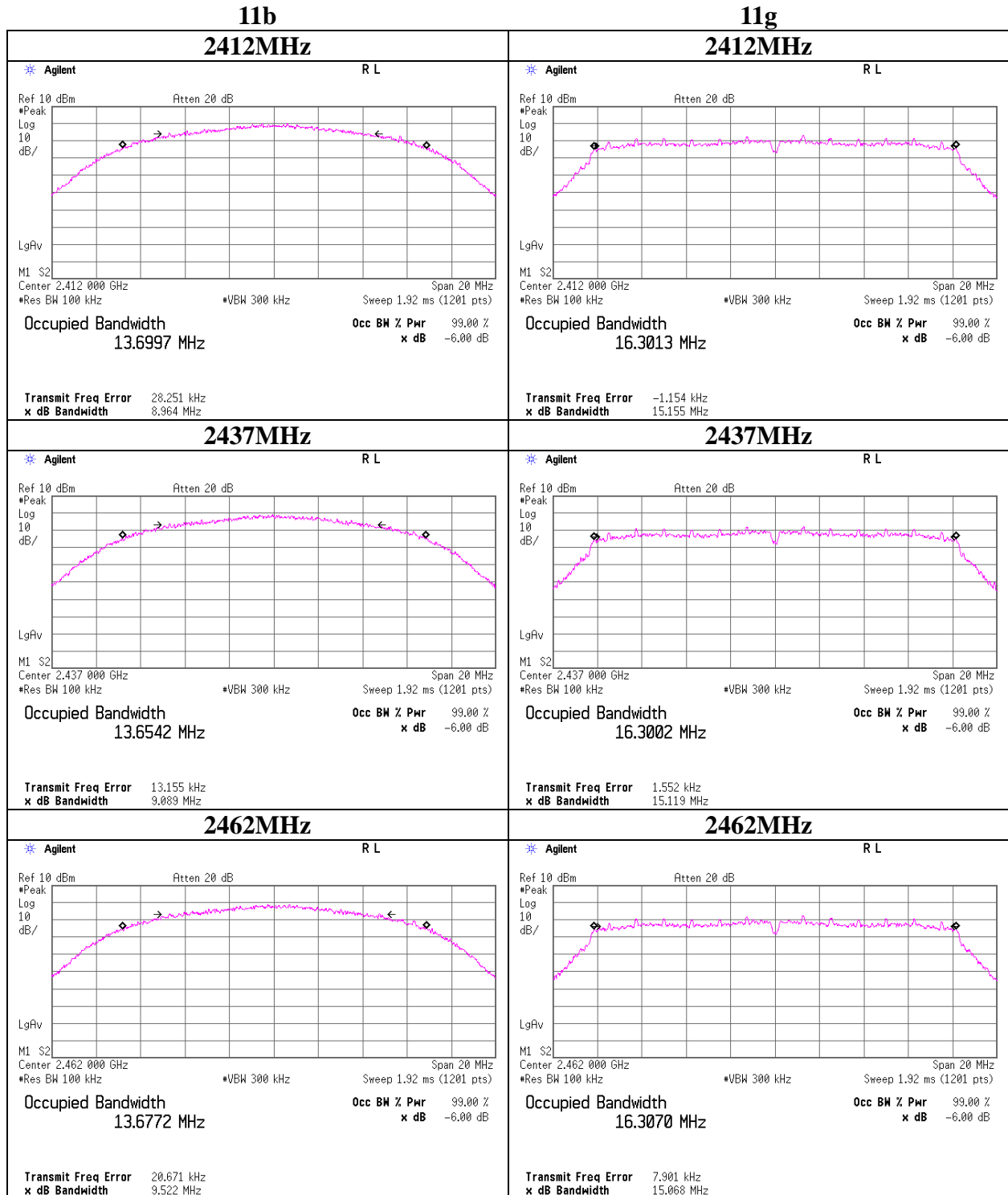

6dB Bandwidth

11n-20

2412MHz

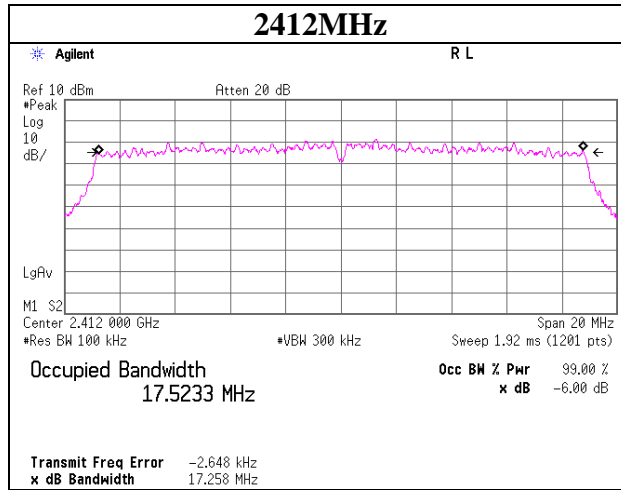

2437MHz

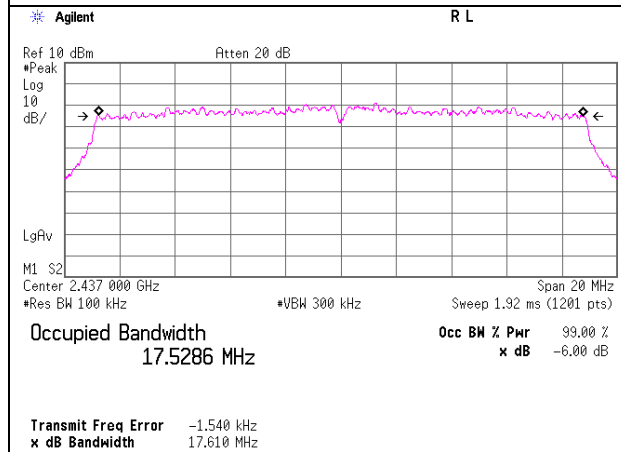

2462MHz

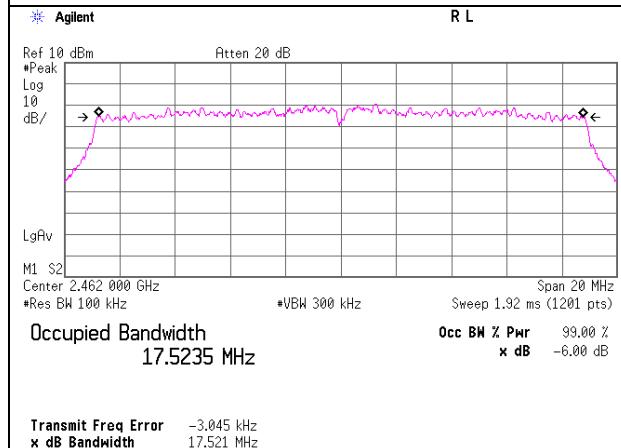

UL Japan, Inc.

Head Office EMC Lab.

4383-326 Asama-cho, Ise-shi, Mie-ken 516-0021 JAPAN

Telephone : +81 596 24 8999

Facsimile : +81 596 24 8124

6dB Bandwidth

Test place	Head Office EMC Lab. No.4 Measurement Room
Report No.	33IE0012-HO
Date	04/16/2013
Temperature/ Humidity	20deg. C / 40% RH
Engineer	Yutaka Yoshida
Mode	Tx Bluetooth Low Energy

Frequency [MHz]	6dB Bandwidth [kHz]	Limit [kHz]
2402	701.174	>500
2440	708.349	>500
2480	708.646	>500

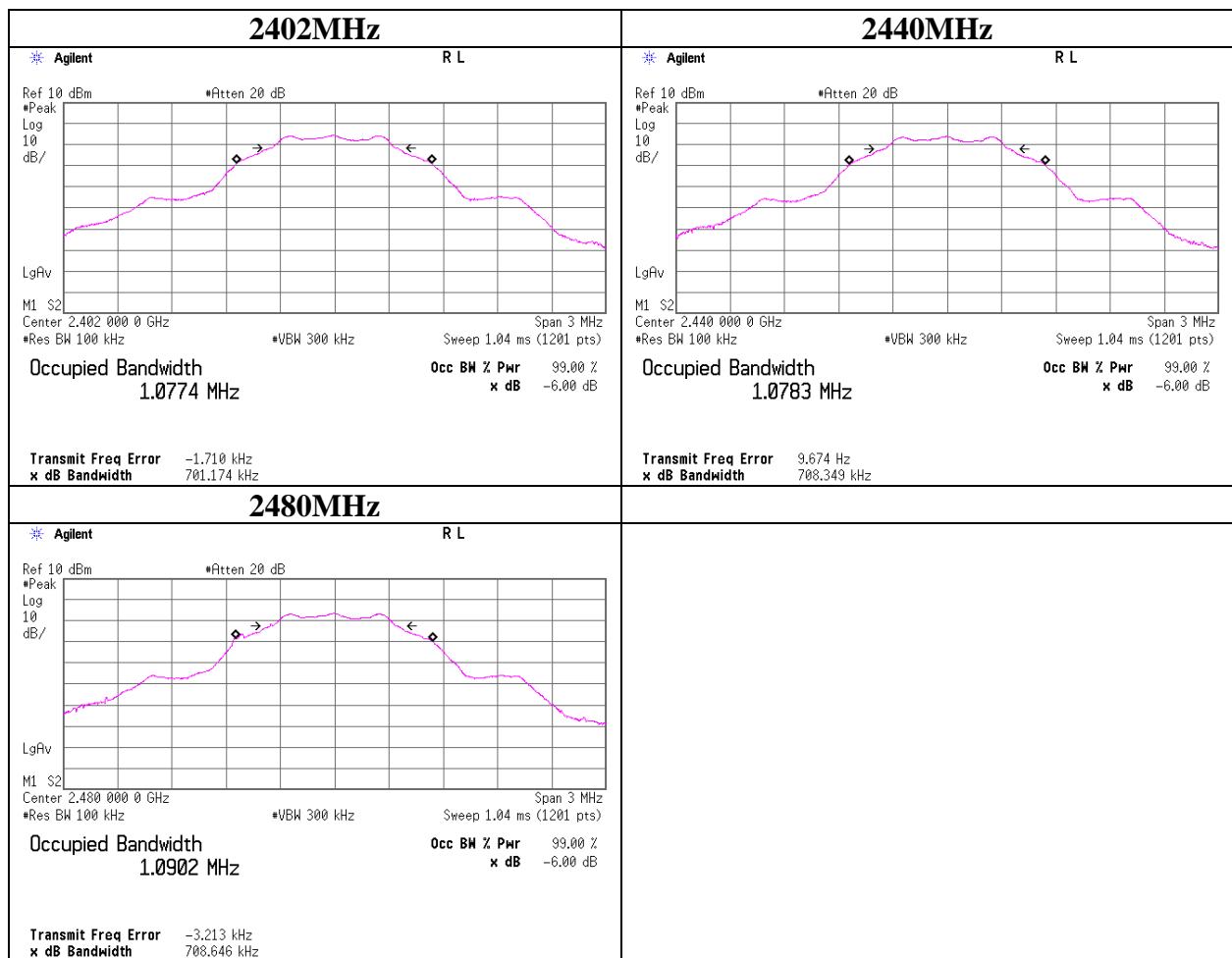

Maximum Peak Output Power

Test place	Head Office EMC Lab. No.6 Measurement Room
Report No.	33IE0012-HO
Date	04/16/2013
Temperature/ Humidity	20deg. C / 40% RH
Engineer	Yutaka Yoshida
Mode	11g Tx

11g 9Mbps

Freq. [MHz]	Reading PK [dBm]	Cable Loss [dB]	Atten. [dB]	Result		Limit		Margin [dB]
				[dBm]	[mW]	[dBm]	[mW]	
2412	12.31	1.00	10.01	23.32	214.78	30.00	1000	6.68
2437	12.27	1.00	10.01	23.28	212.81	30.00	1000	6.72
2462	11.94	1.00	10.01	22.95	197.24	30.00	1000	7.05

Sample Calculation:
Result = Reading + Cable Loss + Attenuator

2437MHz

Rate [Mbps]	Reading PK [dBm]	Remark
6	12.59	
9	12.70	*
12	12.33	
18	12.41	
24	12.47	
36	12.39	
48	12.26	
54	12.26	

*: Worst Rate

All comparison were carried out on same frequency and measurement factors.

*Difference between worst rate check data and formal test result is due to the different test condition.

Maximum Peak Output Power

Test place	Head Office EMC Lab. No.6 Measurement Room
Report No.	33IE0012-HO
Date	04/16/2013
Temperature/ Humidity	20deg. C / 40% RH
Engineer	Yutaka Yoshida
Mode	11n-20 Tx

11n-20 MCS5

Freq. [MHz]	Reading PK [dBm]	Cable Loss [dB]	Atten. [dB]	Result		Limit		Margin [dB]
				[dBm]	[mW]	[dBm]	[mW]	
2412	11.23	1.00	10.01	22.24	167.49	30.00	1000	7.76
2437	11.00	1.00	10.01	22.01	158.85	30.00	1000	7.99
2462	10.73	1.00	10.01	21.74	149.28	30.00	1000	8.26

Sample Calculation:

Result = Reading + Cable Loss + Attenuator

2437MHz

MCS Number	Reading PK [dBm]	Remark
0	11.15	
1	11.23	
2	10.96	
3	10.99	
4	10.85	
5	11.37	*
6	10.98	
7	10.90	

*: Worst Rate

All comparison were carried out on same frequency and measurement factors.

*Difference between worst rate check data and formal test result is due to the different test condition.

UL Japan, Inc.

Head Office EMC Lab.

4383-326 Asama-cho, Ise-shi, Mie-ken 516-0021 JAPAN

Telephone : +81 596 24 8999

Facsimile : +81 596 24 8124

Maximum Peak Output Power

Test place Head Office EMC Lab. No.6 Measurement Room
Report No. 33IE0012-HO
Date 04/16/2013
Temperature/ Humidity 20deg. C / 40% RH
Engineer Yutaka Yoshida
Mode Bluetooth Low Energy Tx

Bluetooth Low Energy

Freq. [MHz]	Reading PK [dBm]	Cable Loss [dB]	Atten. [dB]	Result		Limit		Margin [dB]
				[dBm]	[mW]	[dBm]	[mW]	
2402	-5.47	2.23	10.03	6.79	4.78	30.00	1000	23.21
2440	-5.33	2.24	10.03	6.94	4.94	30.00	1000	23.06
2480	-5.79	2.25	10.03	6.49	4.46	30.00	1000	23.51

Sample Calculation:

Result = Reading + Cable Loss + Attenuator

UL Japan, Inc.

Head Office EMC Lab.

4383-326 Asama-cho, Ise-shi, Mie-ken 516-0021 JAPAN

Telephone : +81 596 24 8999

Facsimile : +81 596 24 8124

Maximum Average Output Power (Reference data for SAR testing)

IEEE802.11b 1Mbps

Ch	Frequency [MHz]	P/M Reading	Cable Loss [dB]	Atten. [dB]	Result	
		AVG			[dBm] AVG	[mW] AVG
1	2412	2.84	1.00	10.01	13.85	24.27
6	2437	3.46	1.00	10.01	14.47	27.99
11	2462	3.13	1.00	10.01	14.14	25.94

Sample Calculation: Result = Reading + Cable Loss + Attenuator

2437MHz

11b Data Rate	Reading AVG [dBm]	Remark
1	6.80	*
2	6.74	
5.5	6.69	
11	6.50	

*: Worst Rate

All comparison were carried out on same frequency and measurement factors.

*Difference between worst rate check data and formal test result is due to the different test cond

IEEE802.11g 6Mbps

Ch	Frequency [MHz]	P/M Reading	Cable Loss [dB]	Atten. [dB]	Result	
		AVG			[dBm] AVG	[mW] AVG
1	2412	1.20	1.00	10.01	12.21	16.63
6	2437	0.81	1.00	10.01	11.82	15.21
11	2462	0.42	1.00	10.01	11.43	13.90

Sample Calculation: Result = Reading + Cable Loss + Attenuator

2437MHz

11g Data Rate	Reading AVG [dBm]	Remark
6	2.03	*
9	2.01	
12	1.89	
18	1.64	
24	1.41	
36	0.98	
48	0.46	
54	0.41	

*: Worst Rate

All comparison were carried out on same frequency and measurement factors.

*Difference between worst rate check data and formal test result is due to the different test cond

UL Japan, Inc.

Head Office EMC Lab.

4383-326 Asama-cho, Ise-shi, Mie-ken 516-0021 JAPAN

Telephone : +81 596 24 8999

Facsimile : +81 596 24 8124

Maximum Average Output Power (Reference data for SAR testing)

IEEE802.11n-20 MCS0

Ch	Frequency [MHz]	P/M Reading	Cable Loss [dB]	Atten. [dB]	Result	
		AVG			[dBm] AVG	[mW] AVG
1	2412	0.20	1.00	10.01	11.21	13.21
6	2437	-0.25	1.00	10.01	10.76	11.91
11	2462	-0.58	1.00	10.01	10.43	11.04

Sample Calculation: Result = Reading + Cable Loss + Attenuator

2437MHz

11n-20 MCS Number	Reading AVG [dBm]	Remark
0	0.09	*
1	-0.18	
2	-0.42	
3	-0.55	
4	-1.03	
5	-1.27	
6	-1.40	
7	-1.52	

*: Worst MCS

All comparison were carried out on same frequency and measurement factors.

*Difference between worst rate check data and formal test result is due to the different test conditi

Bluetooth Low Energy

Freq. [MHz]	Reading AVG [dBm]	Cable Loss [dB]	Atten. [dB]	Result		Limit		Margin [dB]
				[dBm]	[mW]	[dBm]	[mW]	
2402	-7.81	2.23	10.03	4.45	2.79	30.00	1000	25.55
2440	-7.70	2.24	10.03	4.57	2.86	30.00	1000	25.43
2480	-8.16	2.25	10.03	4.12	2.58	30.00	1000	25.88

Sample Calculation:

Result = Reading + Cable Loss + Attenuator

UL Japan, Inc.

Head Office EMC Lab.

4383-326 Asama-cho, Ise-shi, Mie-ken 516-0021 JAPAN

Telephone : +81 596 24 8999

Facsimile : +81 596 24 8124

Radiated Spurious Emission

Test place Head Office EMC Lab. No.2 Semi Anechoic Chamber
Report No. 33IE0012-HO
Date 4/17/2013 4/18/2013
Temperature/ Humidity 23 deg. C / 52% RH 23 deg. C / 52% RH
Engineer Ohnishi Hironobu Tomohisa Nakagawa
1-18GHz Above 18GHz
Mode 11b Tx 2412MHz

Polarity	Frequency [MHz]	Detector	Reading [dBuV]	Ant.Fac. [dB/m]	Loss [dB]	Gain [dB]	Duty Factor [dB]	Result [dBuV/m]	Limit [dBuV/m]	Margin [dB]	Remark
Hori	2386.650	PK	59.6	26.8	2.4	35.7		53.1	73.9	20.8	
Hori	2390.000	PK	58.4	26.8	2.4	35.7		51.9	73.9	22.0	
Hori	4824.000	PK	45.8	30.7	4.3	34.9		45.9	73.9	28.0	
Hori	7236.000	PK	44.5	35.6	4.9	34.9		50.1	73.9	23.8	
Hori	9648.000	PK	43.2	38.2	5.7	35.4		51.7	73.9	22.2	
Hori	2386.650	AV	49.9	26.8	2.4	35.7	0.4	43.8	53.9	10.1	
Hori	2390.000	AV	49.1	26.8	2.4	35.7	0.4	43.0	53.9	10.9	
Hori	4824.000	AV	35.2	30.7	4.3	34.9	0.4	35.7	53.9	18.2	
Hori	7236.000	AV	36.0	35.6	4.9	34.9	0.4	42.0	53.9	11.9	
Hori	9648.000	AV	34.6	38.2	5.7	35.4	0.4	43.5	53.9	10.4	
Vert	2386.650	PK	56.5	26.8	2.4	35.7		50.0	73.9	23.9	
Vert	2390.000	PK	56.4	26.8	2.4	35.7		49.9	73.9	24.0	
Vert	4824.000	PK	46.9	30.7	4.3	34.9		47.0	73.9	26.9	
Vert	7236.000	PK	44.9	35.6	4.9	34.9		50.5	73.9	23.4	
Vert	9648.000	PK	44.0	38.2	5.7	35.4		52.5	73.9	21.4	
Vert	2386.650	AV	47.6	26.8	2.4	35.7	0.4	41.5	53.9	12.4	
Vert	2390.000	AV	46.7	26.8	2.4	35.7	0.4	40.6	53.9	13.3	
Vert	4824.000	AV	35.7	30.7	4.3	34.9	0.4	36.2	53.9	17.7	
Vert	7236.000	AV	36.3	35.6	4.9	34.9	0.4	42.3	53.9	11.6	
Vert	9648.000	AV	36.5	38.2	5.7	35.4	0.4	45.4	53.9	8.5	

Result = Reading + Ant Factor + Loss (Cable+Attenuator+Filter-Distance factor(above 10GHz)) - Gain(Amplifier)

*Other frequency noises omitted in this report were not seen or had enough margin (more than 20dB).

*The 10th harmonic was not seen so the result was its base noise level.

Distance factor: 10GHz-26.5GHz 20log(3.0m/1.0m)= 9.5dB
26.5GHz-40GHz 20log(3.0m/0.5m)=15.6dB

20dBc Data Sheet

Polarity	Frequency [MHz]	Detector	Reading [dBuV]	Ant Factor [dB/m]	Loss [dB]	Gain [dB]	Result [dBuV/m]	Limit [dBuV/m]	Margin [dB]	Remark
Hori	2412.000	PK	113.0	26.8	2.4	35.7	106.5	-	-	Carrier
Hori	2400.000	PK	69.1	26.8	2.4	35.7	62.6	86.5	23.9	
Vert	2412.000	PK	109.5	26.8	2.4	35.7	103.0	-	-	Carrier
Vert	2400.000	PK	66.1	26.8	2.4	35.7	59.6	83.0	23.4	

Result = Reading + Ant Factor + Loss (Cable+Attenuator+Filter-Distance factor(above 10GHz)) - Gain(Amplifier)

UL Japan, Inc.

Head Office EMC Lab.

4383-326 Asama-cho, Ise-shi, Mie-ken 516-0021 JAPAN

Telephone : +81 596 24 8999

Facsimile : +81 596 24 8124

Radiated Spurious Emission

Test place Head Office EMC Lab. No.2 Semi Anechoic Chamber
Report No. 33IE0012-HO
Date 4/17/2013 4/18/2013
Temperature/ Humidity 23 deg. C / 52% RH 23 deg. C / 52% RH
Engineer Ohnishi Hironobu Tomohisa Nakagawa
1-18GHz Above 18GHz
Mode 11b Tx 2437MHz

Polarity	Frequency [MHz]	Detector	Reading [dBuV]	Ant.Fac. [dB/m]	Loss [dB]	Gain [dB]	Duty Factor [dB]	Result [dBuV/m]	Limit [dBuV/m]	Margin [dB]	Remark
Hori	4874.000	PK	44.4	30.8	4.2	34.9		44.5	73.9	29.4	
Hori	7311.000	PK	45.3	35.7	4.9	34.9		51.0	73.9	22.9	
Hori	9748.000	PK	42.9	38.4	5.7	35.4		51.6	73.9	22.3	
Hori	4874.000	AV	35.3	30.8	4.2	34.9	0.4	35.8	53.9	18.1	
Hori	7311.000	AV	37.2	35.7	4.9	34.9	0.4	43.3	53.9	10.6	
Hori	9748.000	AV	34.8	38.4	5.7	35.4	0.4	43.9	53.9	10.0	
Vert	4874.000	PK	44.5	30.8	4.2	34.9		44.6	73.9	29.3	
Vert	7311.000	PK	45.8	35.7	4.9	34.9		51.5	73.9	22.4	
Vert	9748.000	PK	43.8	38.4	5.7	35.4		52.5	73.9	21.4	
Vert	4874.000	AV	35.5	30.8	4.2	34.9	0.4	36.0	53.9	17.9	
Vert	7311.000	AV	37.2	35.7	4.9	34.9	0.4	43.3	53.9	10.6	
Vert	9748.000	AV	35.2	38.4	5.7	35.4	0.4	44.3	53.9	9.6	

Result = Reading + Ant Factor + Loss (Cable+Attenuator+Filter-Distance factor(above 10GHz)) - Gain(Amplifier)

*Other frequency noises omitted in this report were not seen or had enough margin (more than 20dB).

*The 10th harmonic was not seen so the result was its base noise level.

Distance factor: 10GHz-26.5GHz 20log(3.0m/1.0m)= 9.5dB
26.5GHz-40GHz 20log(3.0m/0.5m)=15.6dB

UL Japan, Inc.

Head Office EMC Lab.

4383-326 Asama-cho, Ise-shi, Mie-ken 516-0021 JAPAN

Telephone : +81 596 24 8999

Facsimile : +81 596 24 8124

Radiated Spurious Emission

Test place Head Office EMC Lab. No.2 Semi Anechoic Chamber
Report No. 33IE0012-HO
Date 4/17/2013 4/17/2013 4/18/2013
Temperature/ Humidity 23 deg. C / 52% RH 23 deg. C / 52% RH 23 deg. C / 52% RH
Engineer Tomohisa Nakagawa Ohnishi Hironobu Tomohisa Nakagawa
1-10GHz 10-18GHz Below 1GHz and Above 18GHz
Mode 11g Tx 2412MHz

Polarity	Frequency [MHz]	Detector	Reading [dBuV]	Ant.Fac. [dB/m]	Loss [dB]	Gain [dB]	Duty Factor [dB]	Result [dBuV/m]	Limit [dBuV/m]	Margin [dB]	Remark
Hori	74.793	QP	33.0	6.5	7.2	28.5		18.2	40.0	21.8	
Hori	83.155	QP	38.4	7.0	7.3	28.5		24.2	40.0	15.8	
Hori	175.800	QP	21.5	16.0	8.0	28.0		17.5	43.5	26.0	
Hori	325.000	QP	21.7	14.9	8.9	27.8		17.7	46.0	28.3	
Hori	550.000	QP	22.0	18.6	10.0	28.8		21.8	46.0	24.2	
Hori	611.000	QP	21.8	19.3	10.3	28.8		22.6	46.0	23.4	
Hori	2390.000	PK	63.0	26.8	2.4	35.7		56.5	73.9	17.4	
Hori	4824.000	PK	42.8	30.7	4.3	34.9		42.9	73.9	31.0	
Hori	7236.000	PK	41.9	35.6	4.9	34.9		47.5	73.9	26.4	
Hori	9648.000	PK	43.8	38.2	5.7	35.4		52.3	73.9	21.6	
Hori	2390.000	AV	50.7	26.8	2.4	35.7	0.4	44.6	53.9	9.3	
Hori	4824.000	AV	34.2	30.7	4.3	34.9	0.4	34.7	53.9	19.2	
Hori	7236.000	AV	33.8	35.6	4.9	34.9	0.4	39.8	53.9	14.1	
Hori	9648.000	AV	35.0	38.2	5.7	35.4	0.4	43.9	53.9	10.0	
Vert	73.795	QP	38.2	6.5	7.2	28.5		23.4	40.0	16.6	
Vert	82.346	QP	38.6	6.8	7.3	28.5		24.2	40.0	15.8	
Vert	176.926	QP	25.3	16.0	8.0	28.0		21.3	43.5	22.2	
Vert	325.000	QP	21.2	14.9	8.9	27.8		17.2	46.0	28.8	
Vert	550.000	QP	22.0	18.6	10.0	28.8		21.8	46.0	24.2	
Vert	611.000	QP	21.8	19.3	10.3	28.8		22.6	46.0	23.4	
Vert	2390.000	PK	62.3	26.8	2.4	35.7		55.8	73.9	18.1	
Vert	4824.000	PK	44.1	30.7	4.3	34.9		44.2	73.9	29.7	
Vert	7236.000	PK	41.2	35.6	4.9	34.9		46.8	73.9	27.1	
Vert	9648.000	PK	43.8	38.2	5.7	35.4		52.3	73.9	21.6	
Vert	2390.000	AV	47.2	26.8	2.4	35.7	0.4	41.1	53.9	12.8	
Vert	4824.000	AV	34.1	30.7	4.3	34.9	0.4	34.6	53.9	19.3	
Vert	7236.000	AV	33.8	35.6	4.9	34.9	0.4	39.8	53.9	14.1	
Vert	9648.000	AV	34.8	38.2	5.7	35.4	0.4	43.7	53.9	10.2	

Result = Reading + Ant Factor + Loss (Cable+Attenuator+Filter-Distance factor(above 10GHz)) - Gain(Amplifier)

*Other frequency noises omitted in this report were not seen or had enough margin (more than 20dB).

*The 10th harmonic was not seen so the result was its base noise level.

Distance factor: 10GHz-26.5GHz 20log(3.0m/1.0m)= 9.5dB
26.5GHz-40GHz 20log(3.0m/0.5m)=15.6dB

20dBc Data Sheet

Polarity	Frequency [MHz]	Detector	Reading [dBuV]	Ant Factor [dB/m]	Loss [dB]	Gain [dB]	Result [dBuV/m]	Limit [dBuV/m]	Margin [dB]	Remark
Hori	2412.000	PK	102.9	26.8	2.4	35.7	96.4	-	-	Carrier
Hori	2400.000	PK	63.6	26.8	2.4	35.7	57.1	76.4	19.3	
Vert	2412.000	PK	99.9	26.8	2.4	35.7	93.4	-	-	Carrier
Vert	2400.000	PK	61.2	26.8	2.4	35.7	54.7	73.4	18.7	

Result = Reading + Ant Factor + Loss (Cable+Attenuator+Filter-Distance factor(above 10GHz)) - Gain(Amplifier)

UL Japan, Inc.

Head Office EMC Lab.

4383-326 Asama-cho, Ise-shi, Mie-ken 516-0021 JAPAN

Telephone : +81 596 24 8999

Facsimile : +81 596 24 8124

Radiated Spurious Emission

Test place Head Office EMC Lab. No.2 Semi Anechoic Chamber
Report No. 33IE0012-HO
Date 4/17/2013 4/17/2013 4/18/2013
Temperature/ Humidity 23 deg. C / 52% RH 23 deg. C / 52% RH 23 deg. C / 52% RH
Engineer Tomohisa Nakagawa Ohnishi Hironobu Tomohisa Nakagawa
1-10GHz 10-18GHz Above 18GHz
Mode 11g Tx 2437MHz

Polarity	Frequency [MHz]	Detector	Reading [dBuV]	Ant.Fac. [dB/m]	Loss [dB]	Gain [dB]	Duty Factor [dB]	Result [dBuV/m]	Limit [dBuV/m]	Margin [dB]	Remark
Hori	4874.000	PK	44.3	30.8	4.2	34.9		44.4	73.9	29.5	
Hori	7311.000	PK	42.5	35.7	4.9	34.9		48.2	73.9	25.7	
Hori	9748.000	PK	42.6	38.4	5.7	35.4		51.3	73.9	22.6	
Hori	4874.000	AV	34.4	30.8	4.2	34.9	0.4	34.9	53.9	19.0	
Hori	7311.000	AV	33.9	35.7	4.9	34.9	0.4	40.0	53.9	13.9	
Hori	9748.000	AV	34.8	38.4	5.7	35.4	0.4	43.9	53.9	10.0	
Vert	4874.000	PK	43.4	30.8	4.2	34.9		43.5	73.9	30.4	
Vert	7311.000	PK	44.2	35.7	4.9	34.9		49.9	73.9	24.0	
Vert	9748.000	PK	42.7	38.4	5.7	35.4		51.4	73.9	22.5	
Vert	4874.000	AV	34.1	30.8	4.2	34.9	0.4	34.6	53.9	19.3	
Vert	7311.000	AV	33.9	35.7	4.9	34.9	0.4	40.0	53.9	13.9	
Vert	9748.000	AV	34.8	38.4	5.7	35.4	0.4	43.9	53.9	10.0	

Result = Reading + Ant Factor + Loss (Cable+Attenuator+Filter-Distance factor(above 10GHz)) - Gain(Amplifier)

*Other frequency noises omitted in this report were not seen or had enough margin (more than 20dB).

*The 10th harmonic was not seen so the result was its base noise level.

Distance factor: 10GHz-26.5GHz 20log(3.0m/1.0m)= 9.5dB
26.5GHz-40GHz 20log(3.0m/0.5m)=15.6dB

UL Japan, Inc.

Head Office EMC Lab.

4383-326 Asama-cho, Ise-shi, Mie-ken 516-0021 JAPAN

Telephone : +81 596 24 8999

Facsimile : +81 596 24 8124

Radiated Spurious Emission

Test place Head Office EMC Lab. No.2 Semi Anechoic Chamber
Report No. 33IE0012-HO
Date 4/17/2013 4/17/2013 4/18/2013
Temperature/ Humidity 23 deg. C / 52% RH 23 deg. C / 52% RH 23 deg. C / 52% RH
Engineer Tomohisa Nakagawa Ohnishi Hironobu Tomohisa Nakagawa
1-10GHz 10-18GHz Above 18GHz
Mode 11g Tx 2462MHz

Polarity	Frequency [MHz]	Detector	Reading [dBuV]	Ant.Fac. [dB/m]	Loss [dB]	Gain [dB]	Duty Factor [dB]	Result [dBuV/m]	Limit [dBuV/m]	Margin [dB]	Remark
Hori	2483.500	PK	67.0	26.7	2.4	35.7		60.4	73.9	13.5	
Hori	4924.000	PK	42.7	31.0	4.2	34.9		43.0	73.9	30.9	
Hori	7386.000	PK	42.4	35.8	5.0	34.9		48.3	73.9	25.6	
Hori	9848.000	PK	43.1	38.6	5.8	35.4		52.1	73.9	21.8	
Hori	2483.500	AV	51.5	26.7	2.4	35.7	0.4	45.3	53.9	8.6	
Hori	4924.000	AV	34.0	31.0	4.2	34.9	0.4	34.7	53.9	19.2	
Hori	7386.000	AV	34.3	35.8	5.0	34.9	0.4	40.6	53.9	13.3	
Hori	9848.000	AV	35.5	38.6	5.8	35.4	0.4	44.9	53.9	9.0	
Vert	2483.500	PK	63.4	26.7	2.4	35.7		56.8	73.9	17.1	
Vert	4924.000	PK	43.1	31.0	4.2	34.9		43.4	73.9	30.5	
Vert	7386.000	PK	42.4	35.8	5.0	34.9		48.3	73.9	25.6	
Vert	9848.000	PK	43.1	38.6	5.8	35.4		52.1	73.9	21.8	
Vert	2483.500	AV	47.9	26.7	2.4	35.7	0.4	41.7	53.9	12.2	
Vert	4924.000	AV	33.9	31.0	4.2	34.9	0.4	34.6	53.9	19.3	
Vert	7386.000	AV	34.3	35.8	5.0	34.9	0.4	40.6	53.9	13.3	
Vert	9848.000	AV	35.5	38.6	5.8	35.4	0.4	44.9	53.9	9.0	

Result = Reading + Ant Factor + Loss (Cable+Attenuator+Filter-Distance factor(above 10GHz)) - Gain(Amplifier)

*Other frequency noises omitted in this report were not seen or had enough margin (more than 20dB).

*The 10th harmonic was not seen so the result was its base noise level.

Distance factor: 10GHz-26.5GHz 20log(3.0m/1.0m)= 9.5dB
26.5GHz-40GHz 20log(3.0m/0.5m)=15.6dB

UL Japan, Inc.

Head Office EMC Lab.

4383-326 Asama-cho, Ise-shi, Mie-ken 516-0021 JAPAN

Telephone : +81 596 24 8999

Facsimile : +81 596 24 8124

Radiated Spurious Emission

Test place Head Office EMC Lab. No.2 Semi Anechoic Chamber
Report No. 33IE0012-HO
Date 4/17/2013 4/17/2013 4/18/2013
Temperature/ Humidity 23 deg. C / 52% RH 23 deg. C / 52% RH 20 deg. C / 50% RH
Engineer Tomohisa Nakagawa Hironobu Ohnishi Tomohisa Nakagawa
1-10GHz 10-18GHz Below 1GHz and
18-26.5GHz
Mode BT LE Tx 2440MHz

Polarity	Frequency [MHz]	Detector	Reading [dBuV]	Ant.Fac. [dB/m]	Loss [dB]	Gain [dB]	Duty Factor [dB]	Result [dBuV/m]	Limit [dBuV/m]	Margin [dB]	Remark
Hori	73.653	QP	34.3	6.5	7.2	28.5		19.5	40.0	20.5	
Hori	83.415	QP	38.8	7.0	7.3	28.5		24.6	40.0	15.4	
Hori	175.800	QP	21.7	16.0	8.0	28.0		17.7	43.5	25.8	
Hori	325.000	QP	21.9	14.9	8.9	27.8		17.9	46.0	28.1	
Hori	550.000	QP	22.0	18.6	10.0	28.8		21.8	46.0	24.2	
Hori	611.000	QP	21.8	19.3	10.3	28.8		22.6	46.0	23.4	
Hori	4880.000	PK	46.2	30.9	4.2	34.9		46.4	73.9	27.5	
Hori	7320.000	PK	43.5	35.7	4.9	34.9		49.2	73.9	24.7	
Hori	9760.000	PK	43.7	38.4	5.7	35.4		52.4	73.9	21.5	
Hori	4880.000	AV	37.3	30.9	4.2	34.9	1.8	39.3	53.9	14.6	
Hori	7320.000	AV	34.0	35.7	4.9	34.9	1.8	41.5	53.9	12.4	
Hori	9760.000	AV	35.0	38.4	5.7	35.4	1.8	45.5	53.9	8.4	
Vert	74.805	QP	39.7	6.5	7.2	28.5		24.9	40.0	15.1	
Vert	82.346	QP	40.9	6.8	7.3	28.5		26.5	40.0	13.5	
Vert	176.926	QP	25.9	16.0	8.0	28.0		21.9	43.5	21.6	
Vert	325.000	QP	21.9	14.9	8.9	27.8		17.9	46.0	28.1	
Vert	550.000	QP	22.1	18.6	10.0	28.8		21.9	46.0	24.1	
Vert	611.000	QP	21.8	19.3	10.3	28.8		22.6	46.0	23.4	
Vert	4880.000	PK	43.7	30.9	4.2	34.9		43.9	73.9	30.0	
Vert	7320.000	PK	43.5	35.7	4.9	34.9		49.2	73.9	24.7	
Vert	9760.000	PK	44.9	38.4	5.7	35.4		53.6	73.9	20.3	
Vert	4880.000	AV	34.5	30.9	4.2	34.9	1.8	36.5	53.9	17.4	
Vert	7320.000	AV	34.0	35.7	4.9	34.9	1.8	41.5	53.9	12.4	
Vert	9760.000	AV	35.0	38.4	5.7	35.4	1.8	45.5	53.9	8.4	

Result = Reading + Ant Factor + Loss (Cable+Attenuator+Filter-Distance factor(above 10GHz)) - Gain(Amplifier)

*Other frequency noises omitted in this report were not seen or had enough margin (more than 20dB).

*The 10th harmonic was not seen so the result was its base noise level.

Distance factor: 10GHz-26.5GHz 20log(3.0m/1.0m)= 9.5dB
26.5GHz-40GHz 20log(3.0m/0.5m)=15.6dB

UL Japan, Inc.

Head Office EMC Lab.

4383-326 Asama-cho, Ise-shi, Mie-ken 516-0021 JAPAN

Telephone : +81 596 24 8999

Facsimile : +81 596 24 8124

Duty rate confirmation

11b 11Mbps

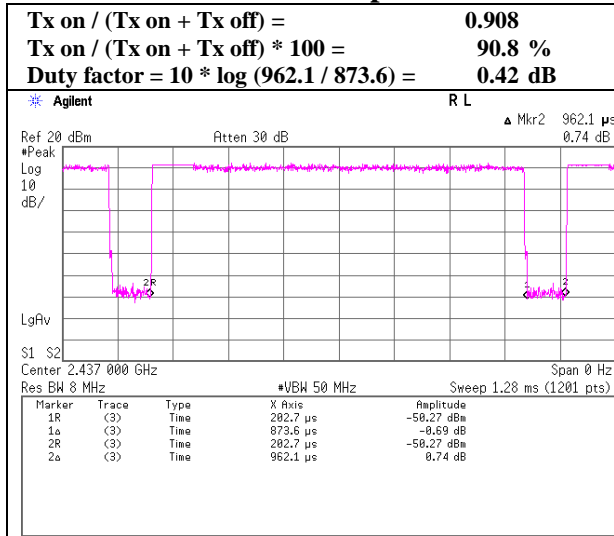

11g 6Mbps

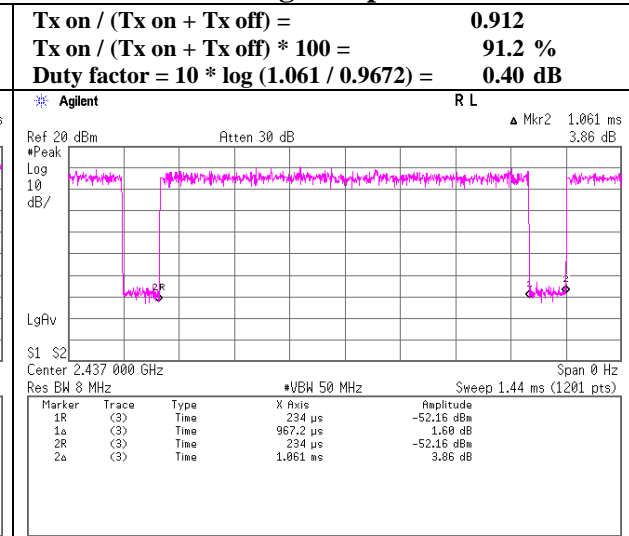

11n-20 MCS5

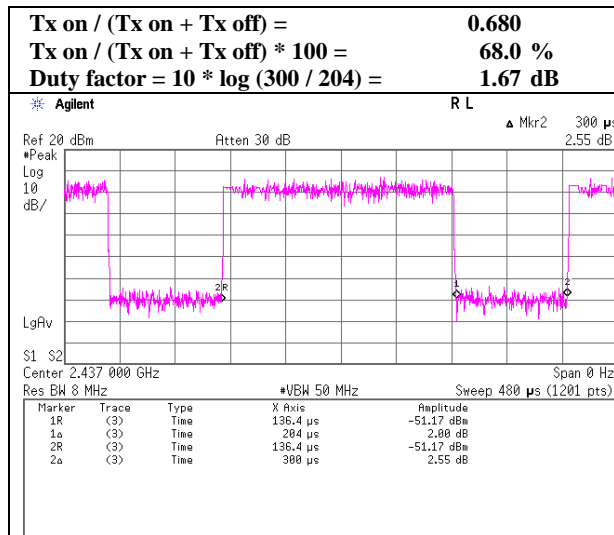

UL Japan, Inc.

Head Office EMC Lab.

4383-326 Asama-cho, Ise-shi, Mie-ken 516-0021 JAPAN

Telephone : +81 596 24 8999

Facsimile : +81 596 24 8124

Duty rate confirmation

Bluetooth Low Energy

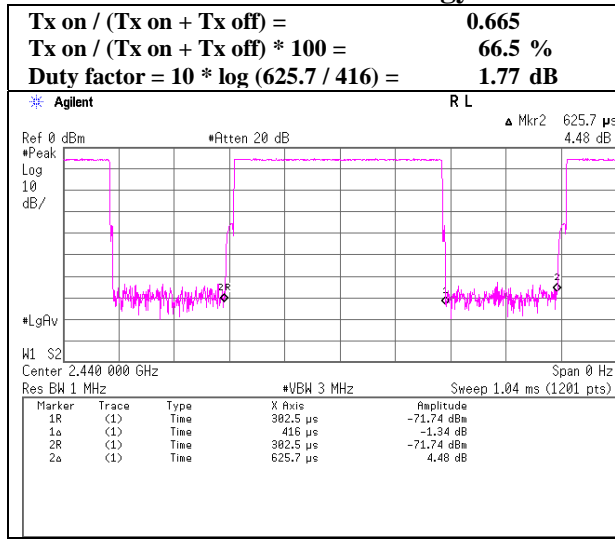

UL Japan, Inc.

Head Office EMC Lab.

4383-326 Asama-cho, Ise-shi, Mie-ken 516-0021 JAPAN

Telephone : +81 596 24 8999

Facsimile : +81 596 24 8124

Conducted Spurious Emission

11g Tx 2412MHz

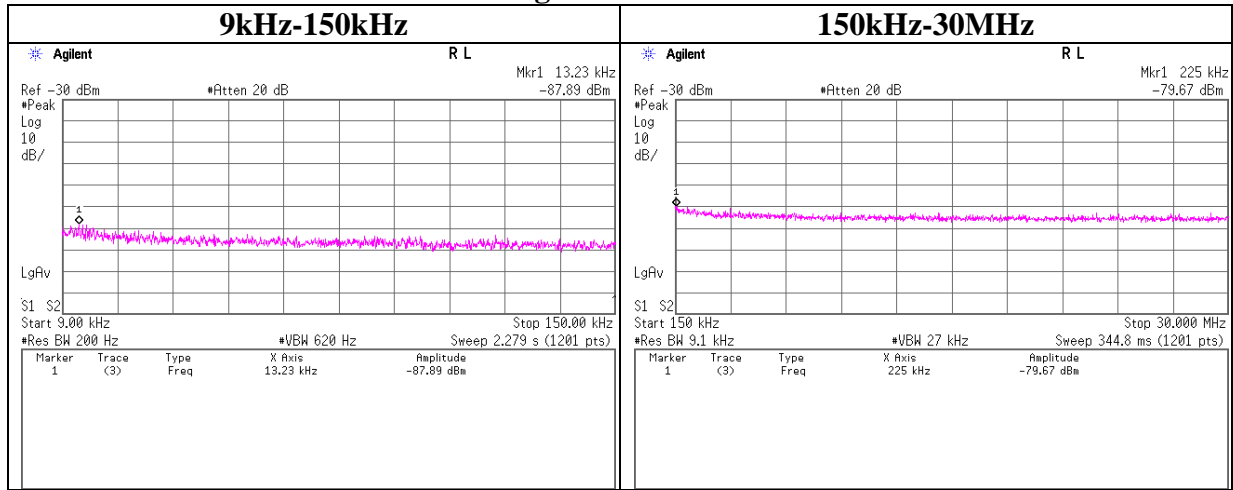

Frequency	Reading	Cable Loss	Attenuator	Antenna Gain	EIRP	Distance	Ground bounce	E (field strength)	Limit
[kHz]	[dBm]	[dB]	[dB]	[dB]	[dBm]	[m]	[dB]	[dBuV/m]	[dBuV/m]
13.230	-87.9	1.79	10.0	2.0	-74.1	300.0	6.0	-12.8	45.2
225.000	-79.7	1.79	10.0	2.0	-65.9	300.0	6.0	-4.6	20.6

E=EIRP-20log(D)+Ground bounce +104.8[dBuV/m]
EIRP=Reading+Cable Loss+Attenuator+Antenna Gain

Conducted Spurious Emission

Bluetooth Low Energy Tx 2402MHz

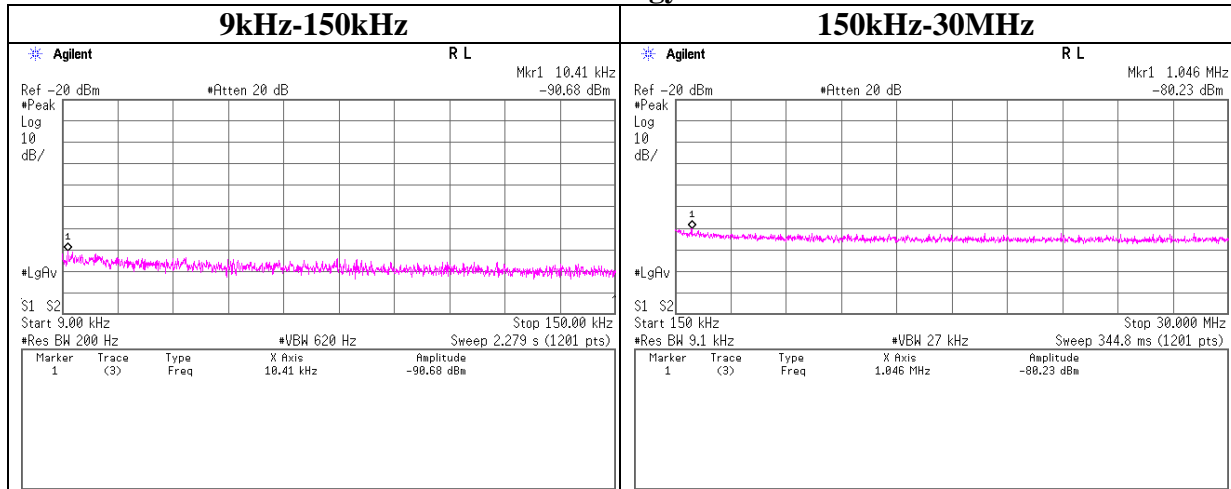

Frequency [kHz]	Reading [dBm]	Cable Loss [dB]	Attenuator [dB]	Antenna Gain [dB]	EIRP [dBm]	Distance [m]	Ground bounce [dB]	E (field strength) [dBuV/m]	Limit [dBuV/m]
10.410	-90.7	1.79	10.0	2.0	-76.9	300.0	6.0	-15.6	47.3
1046.000	-80.2	1.79	10.0	2.0	-66.4	30.0	6.0	14.8	27.2

$E = \text{EIRP} - 20\log(D) + \text{Ground bounce} + 104.8 [\text{dBuV/m}]$

Bluetooth Low Energy Tx 2440MHz

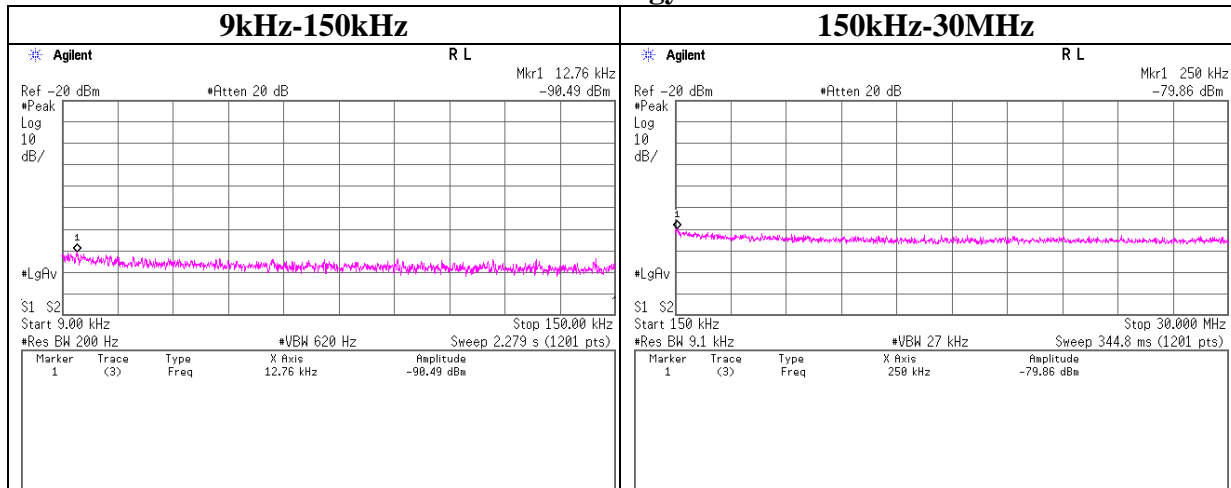

Frequency [kHz]	Reading [dBm]	Cable Loss [dB]	Attenuator [dB]	Antenna Gain [dB]	EIRP [dBm]	Distance [m]	Ground bounce [dB]	E (field strength) [dBuV/m]	Limit [dBuV/m]
12.760	-90.5	1.79	10.0	2.0	-76.7	300.0	6.0	-15.4	45.5
250.000	-79.9	1.79	10.0	2.0	-66.1	300.0	6.0	-4.8	19.6

$E = \text{EIRP} - 20\log(D) + \text{Ground bounce} + 104.8 [\text{dBuV/m}]$

UL Japan, Inc.

Head Office EMC Lab.

4383-326 Asama-cho, Ise-shi, Mie-ken 516-0021 JAPAN

Telephone : +81 596 24 8999

Facsimile : +81 596 24 8124

Conducted Spurious Emission

Bluetooth Low Energy Tx 2480MHz

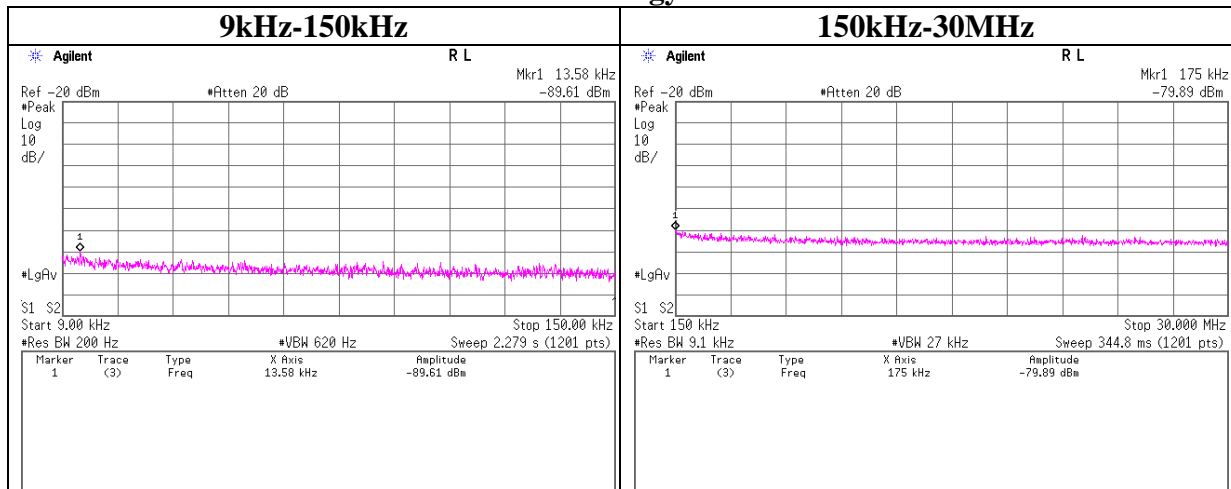

Frequency	Reading	Cable Loss	Attenuator	Antenna Gain	EIRP	Distance	Ground bounce	E (field strength)	Limit
[kHz]	[dBm]	[dB]	[dB]	[dB]	[dBm]	[m]	[dB]	[dBuV/m]	[dBuV/m]
13.580	-89.6	1.79	10.0	2.0	-75.8	300.0	6.0	-14.6	44.9
175.000	-79.9	1.79	10.0	2.0	-66.1	300.0	6.0	-4.8	22.7

$E = \text{EIRP} - 20 \log(D) + \text{Ground bounce} + 104.8 [\text{dBuV/m}]$

UL Japan, Inc.

Head Office EMC Lab.

4383-326 Asama-cho, Ise-shi, Mie-ken 516-0021 JAPAN

Telephone : +81 596 24 8999

Facsimile : +81 596 24 8124

Power Density

Test place Head Office EMC Lab. No.6 Measurement Room
Report No. 33IE0012-HO
Date 05/01/2013
Temperature/ Humidity 24deg. C / 34% RH
Engineer Kazuya Yoshioka
Mode 11b Tx, 11g Tx, 11n-20 Tx

11b 11Mbps

Freq. [MHz]	Reading [dBm]	Cable Loss [dB]	Atten. [dB]	Result [dBm]	Limit [dBm]	Margin [dB]
2412	-20.62	2.29	9.95	-8.38	8.00	16.38
2437	-21.71	2.30	9.95	-9.46	8.00	17.46
2462	-20.81	2.30	9.95	-8.56	8.00	16.56

11g 9Mbps

Freq. [MHz]	Reading [dBm]	Cable Loss [dB]	Atten. [dB]	Result [dBm]	Limit [dBm]	Margin [dB]
2412	-24.76	2.29	9.95	-12.52	8.00	20.52
2437	-23.79	2.30	9.95	-11.54	8.00	19.54
2462	-25.12	2.30	9.95	-12.87	8.00	20.87

11n-20 MCS5

Freq. [MHz]	Reading [dBm]	Cable Loss [dB]	Atten. [dB]	Result [dBm]	Limit [dBm]	Margin [dB]
2412	-26.61	2.29	9.95	-14.37	8.00	22.37
2437	-26.70	2.30	9.95	-14.45	8.00	22.45
2462	-26.98	2.30	9.95	-14.73	8.00	22.73

Sample Calculation:

$$\text{Result} = \text{Reading} + \text{Cable Loss} + \text{Attenuator}$$

UL Japan, Inc.

Head Office EMC Lab.

4383-326 Asama-cho, Ise-shi, Mie-ken 516-0021 JAPAN

Telephone : +81 596 24 8999

Facsimile : +81 596 24 8124

Power Density

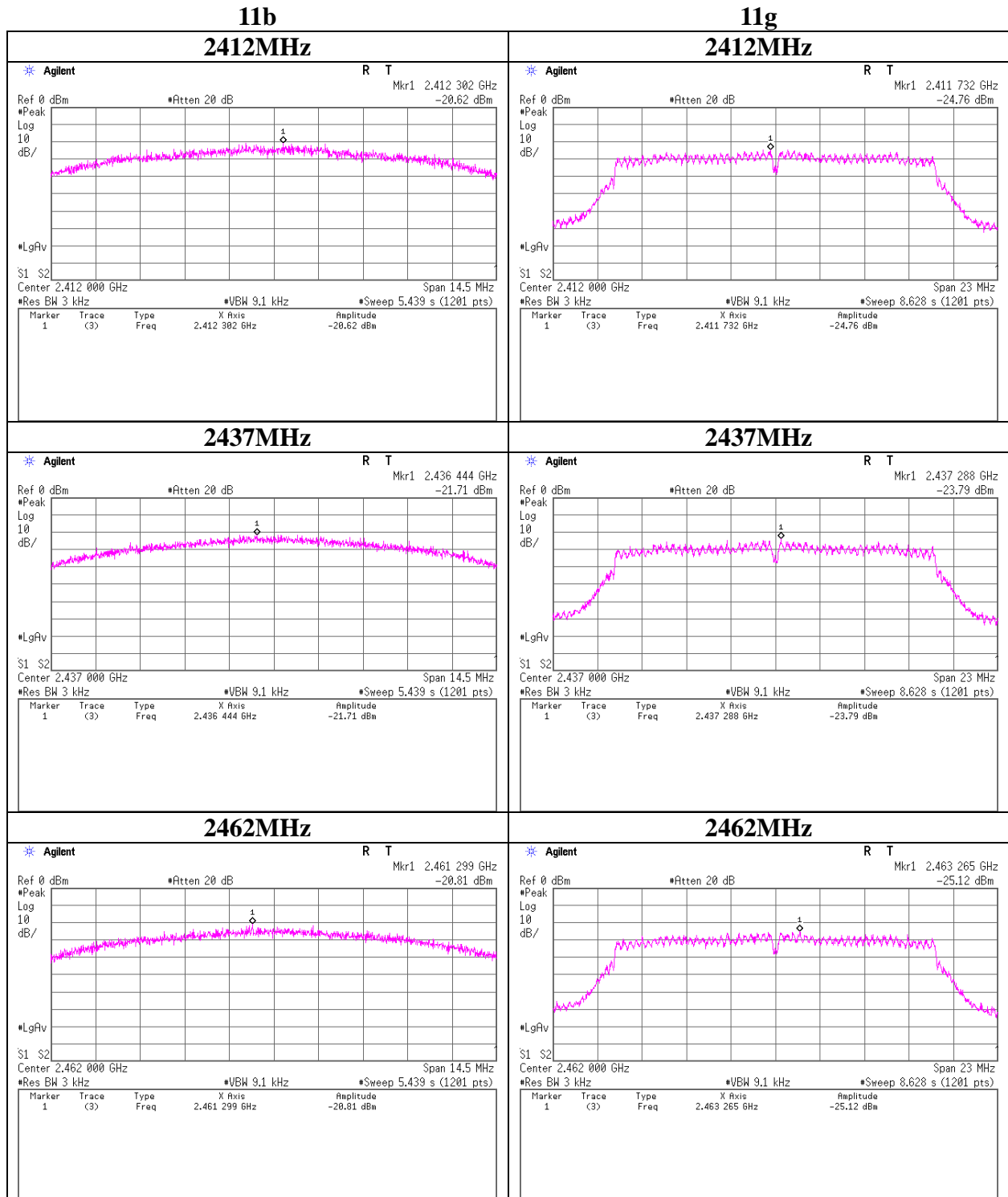

Power Density

11n-20

2412MHz

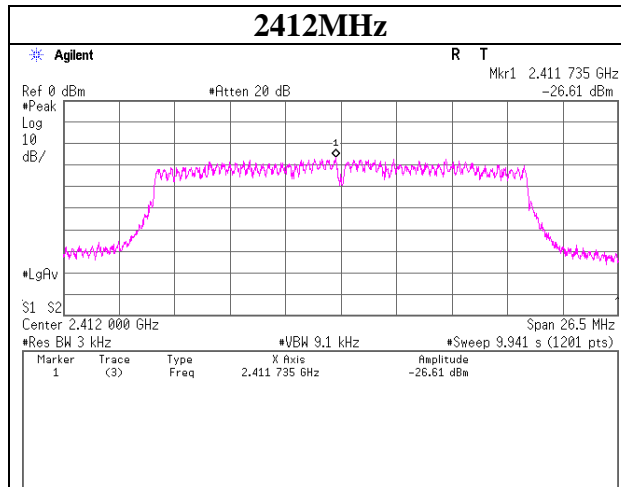

2437MHz

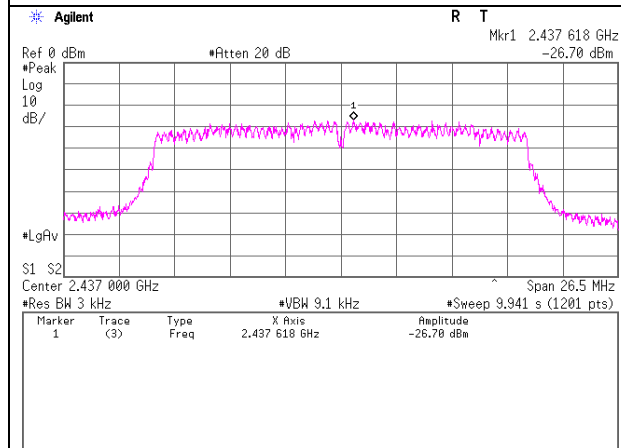

2462MHz

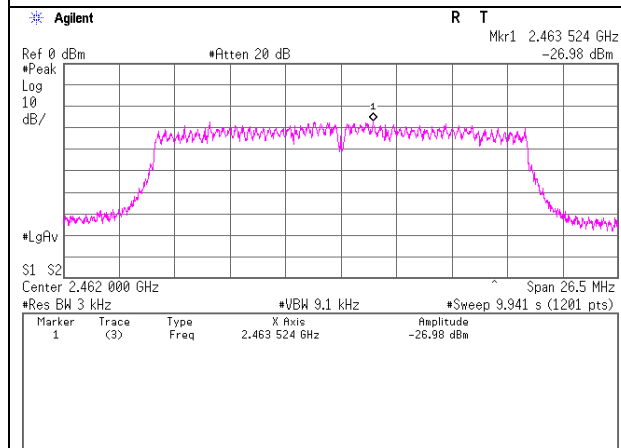

UL Japan, Inc.

Head Office EMC Lab.

4383-326 Asama-cho, Ise-shi, Mie-ken 516-0021 JAPAN

Telephone : +81 596 24 8999

Facsimile : +81 596 24 8124

Power Density

Test place Head Office EMC Lab. No.6 Measurement Room
Report No. 33IE0012-HO
Date 04/16/2013
Temperature/ Humidity 20deg. C / 40% RH
Engineer Yutaka Yoshida
Mode Bluetooth Low Energy

Freq. [MHz]	Reading [dBm]	Cable Loss [dB]	Atten. [dB]	Result [dBm]	Limit [dBm]	Margin [dB]
2402.00	-19.66	2.23	10.03	-7.40	8.00	15.40
2440.00	-19.43	2.24	10.03	-7.16	8.00	15.16
2480.00	-19.92	2.25	10.03	-7.64	8.00	15.64

Sample Calculation:

Result = Reading + Cable Loss + Attenuator

UL Japan, Inc.

Head Office EMC Lab.

4383-326 Asama-cho, Ise-shi, Mie-ken 516-0021 JAPAN

Telephone : +81 596 24 8999

Facsimile : +81 596 24 8124

Power Density

Tx

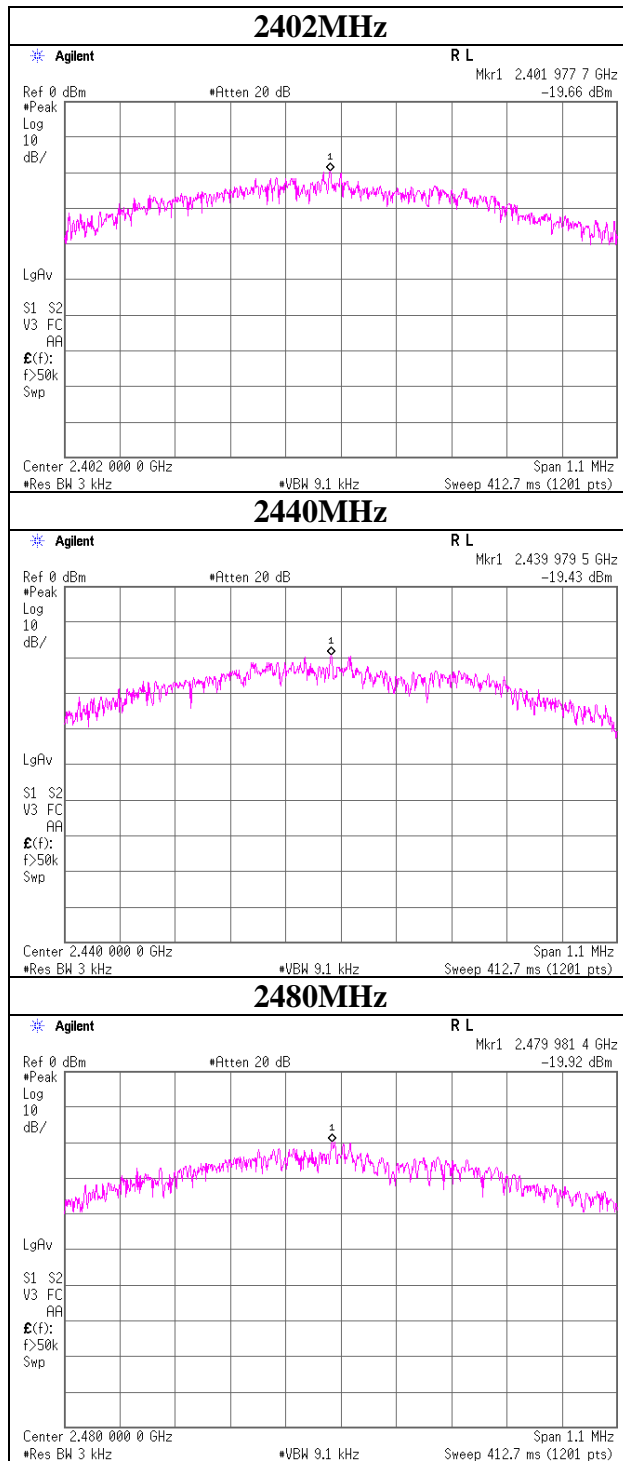

UL Japan, Inc.

Head Office EMC Lab.

4383-326 Asama-cho, Ise-shi, Mie-ken 516-0021 JAPAN

Telephone : +81 596 24 8999

Facsimile : +81 596 24 8124

99%Occupied Bandwidth

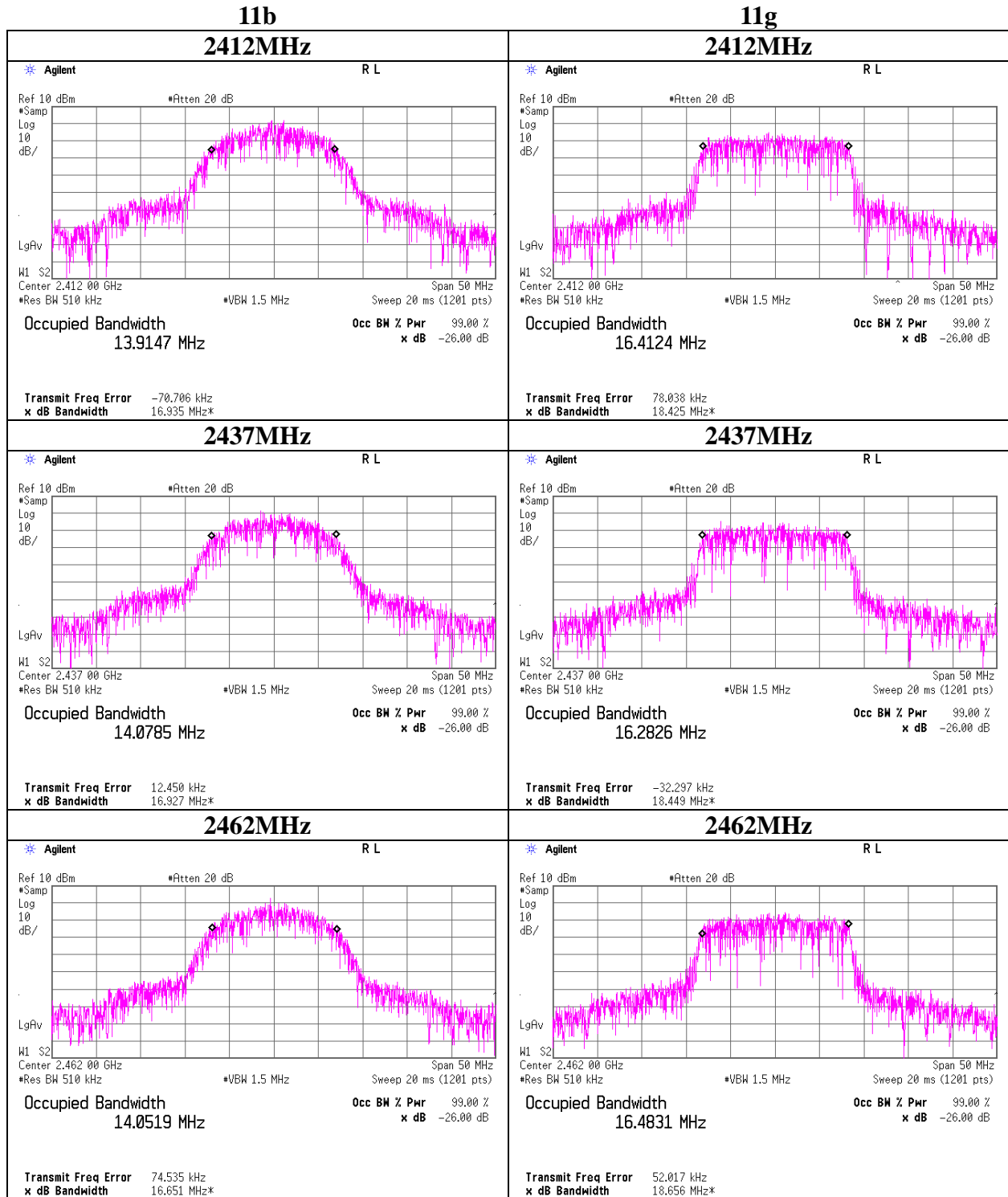

99% Occupied Bandwidth

11n-20

2412MHz

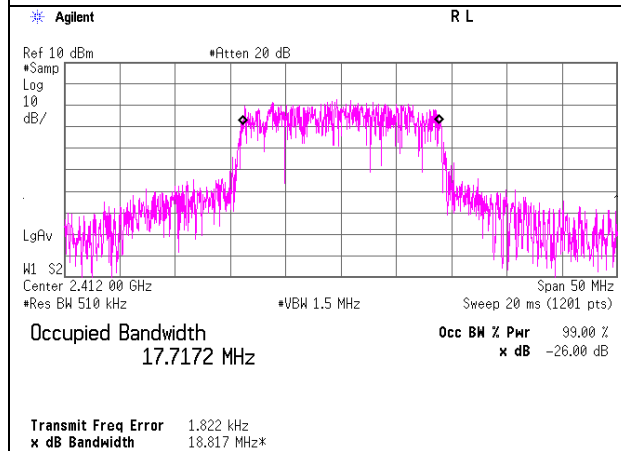

2437MHz

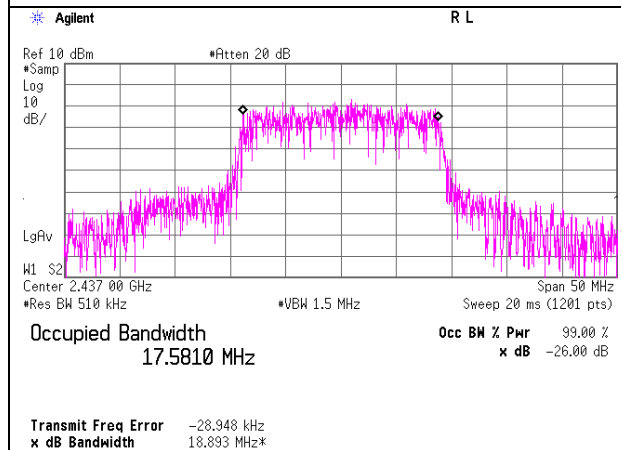

2462MHz

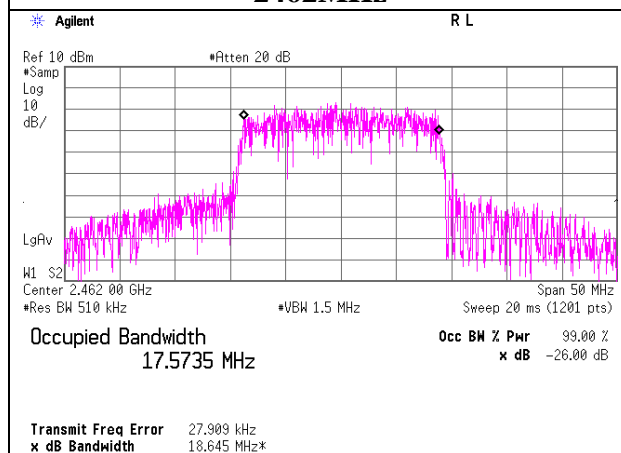

99% Occupied Bandwidth

Bluetooth Low Energy

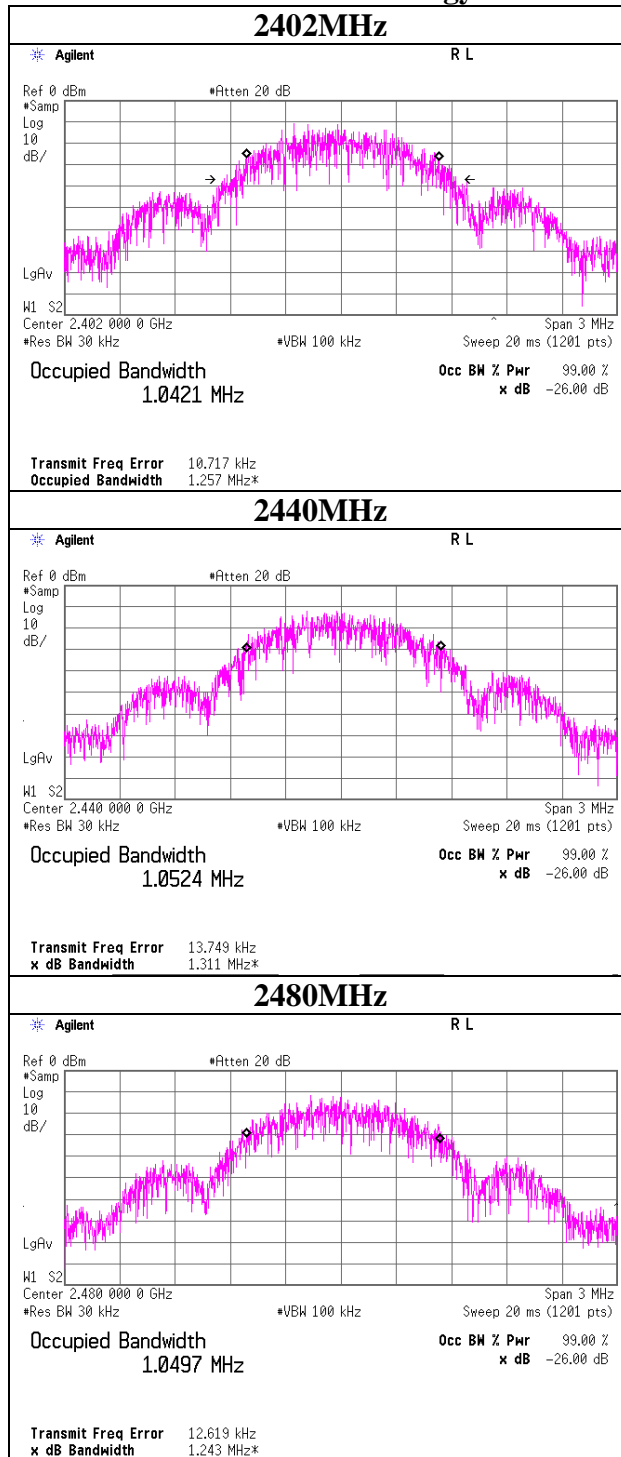

UL Japan, Inc.

Head Office EMC Lab.

4383-326 Asama-cho, Ise-shi, Mie-ken 516-0021 JAPAN

Telephone : +81 596 24 8999

Facsimile : +81 596 24 8124

APPENDIX 2: Test instruments

EMI test equipment

Control No.	Instrument	Manufacturer	Model No	Serial No	Test Item	Calibration Date * Interval(month)
MSA-10	Spectrum Analyzer	Agilent	E4448A	MY46180655	AT	2013/02/22 * 12
MPM-08	Power Meter	Anritsu	ML2495A	6K00003338	AT	2012/10/08 * 12
MPSE-11	Power sensor	Anritsu	MA2411B	011737	AT	2012/10/08 * 12
MCC-66	Microwave Cable 1G-40GHz	Suhner	SUCOFLEX102	28636/2	AT	2013/04/17 * 12
MAT-25	Attenuator(10dB) (above1GHz)	Agilent	8493C	71642	AT	2012/06/27 * 12
MOS-14	Thermo-Hygrometer	Custom	CTH-201	-	AT	2013/02/26 * 12
MMM-11	Digital HiTESTER	Hioki	3805	060100600	AT	2012/05/18 * 12
MDPS-20	REGULATED DC POWER SUPPLY	TEXIO	PW16-5ADP	171116437	AT	Pre Check
MAT-24	Attenuator(10dB)(abo ve1GHz)	Agilent	8493C	71389	AT	2012/06/27 * 12
MAEC-02	Semi Anechoic Chamber(NSA)	TDK	Semi Anechoic Chamber 3m	DA-06902	RE/CE	2012/06/29 * 12
MOS-22	Thermo-Hygrometer	Custom	CTH-201	0003	RE/CE	2013/02/26 * 12
MJM-14	Measure	KOMELON	KMC-36	-	RE/CE	-
COTS-MEMI	EMI measurement program	TSJ	TEPTO-DV	-	RE/CE	-
MSA-04	Spectrum Analyzer	Agilent	E4448A	US44300523	RE/CE	2013/04/03 * 12
MHA-06	Horn Antenna 1-18GHz	Schwarzbeck	BBHA9120D	254	RE	2013/02/15 * 12
MPA-10	Pre Amplifier	Agilent	8449B	3008A02142	RE	2013/01/10 * 12
MHA-17	Horn Antenna 15-40GHz	Schwarzbeck	BBHA9170	BBHA9170307	RE	2012/06/27 * 12
MCC-132	Microwave Cable	HUBER+SUHNER	SUCOFLEX104	336161/4(1m) / 340639(5m)	RE	2012/09/05 * 12
MHF-06	High Pass Filter 3.5-24GHz	TOKIMEC	TF323DCA	601	RE	2012/05/30 * 12
MTR-03	Test Receiver	Rohde & Schwarz	ESCI	100300	RE/CE	2013/04/10 * 12
MBA-02	Biconical Antenna	Schwarzbeck	BBA9106	VHA91032008	RE	2012/10/08 * 12
MLA-02	Logperiodic Antenna	Schwarzbeck	USLP9143	201	RE	2012/10/08 * 12
MCC-12	Coaxial Cable	Fujikura/Agilent	-	-	RE	2013/02/06 * 12
MAT-07	Attenuator(6dB)	Weinschel Corp	2	BK7970	RE	2012/11/06 * 12
MPA-09	Pre Amplifier	Agilent	8447D	2944A10845	RE	2012/09/11 * 12
MLS-07	LISN(AMN)	Schwarzbeck	NSLK8127	8127364	CE	2013/01/07 * 12
MCC-13	Coaxial Cable	Fujikura	3D-2W(12m)/ 5D-2W(5m)/ 5D-2W(0.8m)/ 5D-2W(1m)	-	CE	2013/02/06 * 12
MAT-65	Attenuator(13dB)	JFW Industries, Inc.	50FP-013H2 N	-	CE	2013/01/09 * 12
MJG-52	Extension Tap EU	UL Japan			CE	-

The expiration date of the calibration is the end of the expired month.

All equipment is calibrated with valid calibrations. Each measurement data is traceable to the national or international standards.

As for some calibrations performed after the tested dates, those test equipment have been controlled by means of an unbroken chains of calibrations.

Test Item: CE: Conducted Emission
RE: Radiated Emission
AT: Antenna Terminal Conducted test

UL Japan, Inc.

Head Office EMC Lab.

4383-326 Asama-cho, Ise-shi, Mie-ken 516-0021 JAPAN

Telephone : +81 596 24 8999

Facsimile : +81 596 24 8124