



SAR EVALUATION REPORT

Applicant Name:
 Samsung Electronics, Co. Ltd.
 129, Samsung-ro, Maetan dong,
 Yeongtong-gu, Suwon-si
 Gyeonggi-do 443-742, Korea

Date of Testing:
 11/04/13-11/06/13
Test Site/Location:
 PCTEST Lab, Columbia, MD, USA
Document Serial No.:
 OY1310312083.A3L

FCC ID: A3LGTS6790E

APPLICANT: SAMSUNG ELECTRONICS, CO. LTD.

DUT Type: Portable Handset
Application Type: Certification
FCC Rule Part(s): CFR §2.1093
Model(s): GT-S6790E

| Equipment Class | Band & Mode | Tx Frequency | Measured Conducted Power [dBm] | SAR | | |
|---|----------------------------|-----------------------|--------------------------------|------------------|-----------------------|---------------------|
| | | | | 1 gm Head (W/kg) | 1 gm Body-Worn (W/kg) | 1 gm Hotspot (W/kg) |
| PCE | GSM/GPRS/EDGE Rx Only 850 | 824.20 - 848.80 MHz | 32.49 | 0.40 | 0.65 | 0.65 |
| PCE | GSM/GPRS/EDGE Rx Only 1900 | 1850.20 - 1909.80 MHz | 29.01 | 0.47 | 0.38 | 0.48 |
| PCE | UMTS 1900 | 1852.4 - 1907.6 MHz | 22.94 | 0.64 | 0.51 | 0.51 |
| DTS | 2.4 GHz WLAN | 2412 - 2462 MHz | 15.20 | 0.62 | 0.25 | 0.29 |
| DSS/DTS | Bluetooth | 2402 - 2480 MHz | 9.30 | N/A | | |
| Simultaneous SAR per KDB 690783 D01v01r02: | | | | 1.00 | 0.90 | 0.91 |



Note: Powers in the above table represent output powers for the SAR test configurations and may not represent the highest output powers for all configurations for each mode.

This wireless portable device has been shown to be capable of compliance for localized specific absorption rate (SAR) for uncontrolled environment/general population exposure limits specified in ANSI/IEEE C95.1-1992 and has been tested in accordance with the measurement procedures specified in Section 1.7 of this report; for North American frequency bands only.

I attest to the accuracy of data. All measurements reported herein were performed by me or were made under my supervision and are correct to the best of my knowledge and belief. I assume full responsibility for the completeness of these measurements and vouch for the qualifications of all persons taking them. Test results reported herein relate only to the item(s) tested.



 Randy Ortanez
 President



| | | | | |
|-----------------------------------|---|-------------------------------|---|---------------------------------|
| FCC ID: A3LGTS6790E |  | SAR EVALUATION REPORT |  | Reviewed by: Quality Manager |
| Document S/N: OY1310312083.A3L | Test Dates: 11/04/13 - 11/06/13 | DUT Type: Portable Handset | Page 1 of 35 | |

T A B L E O F C O N T E N T S

| | | |
|---|--|----|
| 1 | DEVICE UNDER TEST | 3 |
| 2 | INTRODUCTION | 7 |
| 3 | DOSIMETRIC ASSESSMENT | 8 |
| 4 | DEFINITION OF REFERENCE POINTS | 9 |
| 5 | TEST CONFIGURATION POSITIONS FOR HANDSETS | 10 |
| 6 | RF EXPOSURE LIMITS | 14 |
| 7 | FCC MEASUREMENT PROCEDURES..... | 15 |
| 8 | RF CONDUCTED POWERS..... | 18 |
| 9 | SYSTEM VERIFICATION..... | 21 |
| 10 | SAR DATA SUMMARY | 23 |
| 11 | FCC MULTI-TX AND ANTENNA SAR CONSIDERATIONS..... | 27 |
| 12 | SAR MEASUREMENT VARIABILITY | 30 |
| 13 | EQUIPMENT LIST..... | 31 |
| 14 | MEASUREMENT UNCERTAINTIES | 32 |
| 15 | CONCLUSION..... | 33 |
| 16 | REFERENCES | 34 |
| APPENDIX A: SAR TEST PLOTS | | |
| APPENDIX B: SAR DIPOLE VERIFICATION PLOTS | | |
| APPENDIX C: PROBE AND DIPOLE CALIBRATION CERTIFICATES | | |
| APPENDIX D: SAR TISSUE SPECIFICATIONS | | |
| APPENDIX E: SAR SYSTEM VALIDATION | | |
| APPENDIX F: SAR TEST SETUP PHOTOGRAPHS | | |

| | | | | |
|-----------------------------------|---|-------------------------------|---|---------------------------------|
| FCC ID: A3LGTS6790E |  | SAR EVALUATION REPORT |  | Reviewed by: Quality Manager |
| Document S/N: 0Y1310312083.A3L | Test Dates: 11/04/13 - 11/06/13 | DUT Type: Portable Handset | Page 2 of 35 | |

1 DEVICE UNDER TEST

1.1 Device Overview

| Band & Mode | Operating Modes | Tx Frequency |
|----------------------------|-----------------|-----------------------|
| GSM/GPRS/EDGE Rx Only 850 | Voice/Data | 824.20 - 848.80 MHz |
| GSM/GPRS/EDGE Rx Only 1900 | Voice/Data | 1850.20 - 1909.80 MHz |
| UMTS 1900 | Voice/Data | 1852.4 - 1907.6 MHz |
| 2.4 GHz WLAN | Data | 2412 - 2462 MHz |
| Bluetooth | Data | 2402 - 2480 MHz |



1.2 Nominal and Maximum Output Power Specifications

This device operates using the following maximum and nominal output power specifications. SAR values were scaled to the maximum allowed power to determine compliance per KDB Publication 447498 D01v05.

| Mode / Band | | Voice (dBm) | Burst Average GMSK (dBm) | | | |
|---------------|---------|-------------|--------------------------|-------------|-------------|-------------|
| | | 1 TX Slot | 1 TX Slots | 2 TX Slots | 3 TX Slots | 4 TX Slots |
| GSM/GPRS 850 | Maximum | 33.0 | 33.0 | 30.5 | 28.5 | 27.5 |
| | Nominal | 32.5 | 32.5 | 30.0 | 28.0 | 27.0 |
| GSM/GPRS 1900 | Maximum | 29.5 | 29.5 | 27.5 | 25.5 | 24.5 |
| | Nominal | 29.0 | 29.0 | 27.0 | 25.0 | 24.0 |

| Mode / Band | | Modulated Average (dBm) | | |
|------------------------|---------|-------------------------|------------------|------------------|
| | | 3GPP WCDMA Rel 99 | 3GPP HSDPA Rel 5 | 3GPP HSUPA Rel 6 |
| UMTS Band 2 (1900 MHz) | Maximum | 23.0 | 23.0 | 21.5 |
| | Nominal | 22.5 | 22.5 | 21.0 |

| Mode / Band | | Modulated Average (dBm) |
|------------------------|---------|-------------------------|
| IEEE 802.11b (2.4 GHz) | Maximum | 15.5 |
| | Nominal | 15.0 |
| IEEE 802.11g (2.4 GHz) | Maximum | 11.5 |
| | Nominal | 11.0 |
| IEEE 802.11n (2.4 GHz) | Maximum | 8.5 |
| | Nominal | 8.0 |
| Bluetooth | Maximum | 10.0 |
| | Nominal | 9.5 |
| Bluetooth LE | Maximum | 6.5 |
| | Nominal | 6.0 |

| | | | | |
|-----------------------------------|---|-------------------------------|---|---------------------------------|
| FCC ID: A3LGTS6790E |  | SAR EVALUATION REPORT |  | Reviewed by: Quality Manager |
| Document S/N: OY1310312083.A3L | Test Dates: 11/04/13 - 11/06/13 | DUT Type: Portable Handset | Page 3 of 35 | |

1.3 DUT Antenna Locations

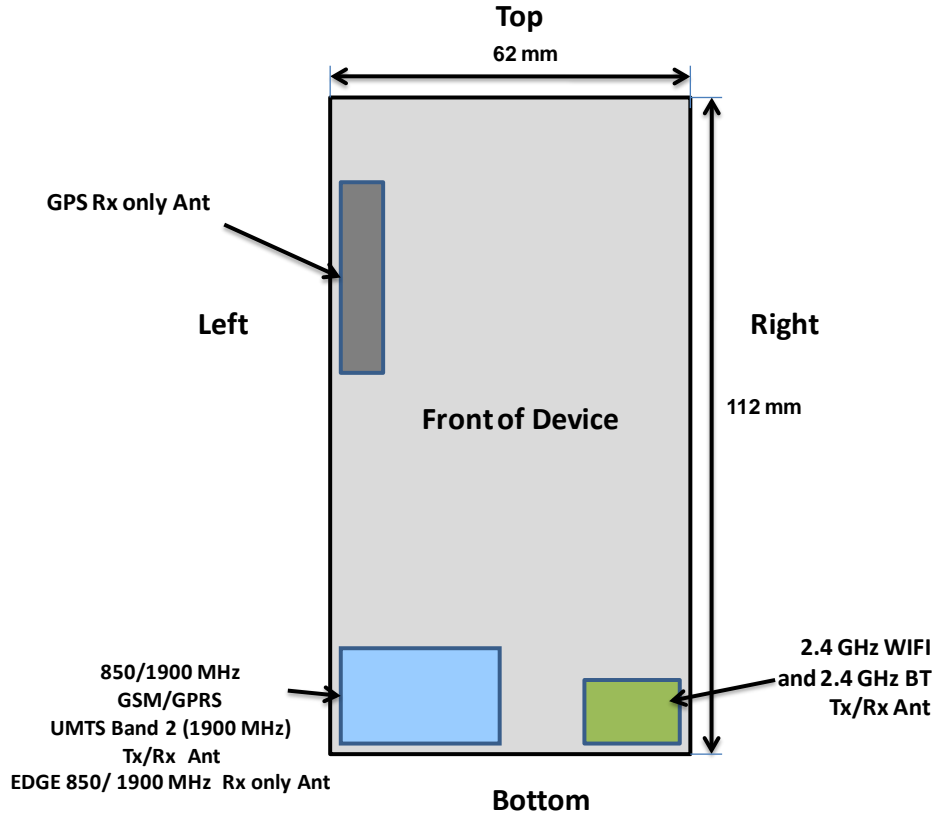



Note: Exact antenna dimensions and separation distances are shown in the Technical Descriptions in the FCC Filing.

Figure 1-1
DUT Antenna Locations

Table 1-1
Mobile Hotspot Sides for SAR Testing

| Mobile Hotspot Sides for SAR Testing | | | | | | |
|--------------------------------------|------|-------|-----|--------|-------|------|
| Mode | Back | Front | Top | Bottom | Right | Left |
| GPRS 850 | Yes | Yes | No | Yes | No | Yes |
| GPRS 1900 | Yes | Yes | No | Yes | No | Yes |
| UMTS 1900 | Yes | Yes | No | Yes | No | Yes |
| 2.4 GHz WLAN | Yes | Yes | No | Yes | Yes | No |

Note: Particular DUT edges were not required to be evaluated for Wireless Router SAR if the edges were greater than 2.5 cm from the transmitting antenna according to FCC KDB Publication 941225 D06v01 guidance, page 2.

| | | | | |
|-----------------------------------|---|-------------------------------|---|---------------------------------|
| FCC ID: A3LGTS6790E |  | SAR EVALUATION REPORT |  | Reviewed by: Quality Manager |
| Document S/N: OY1310312083.A3L | Test Dates: 11/04/13 - 11/06/13 | DUT Type: Portable Handset | | Page 4 of 35 |

1.4 Simultaneous Transmission Capabilities

According to FCC KDB Publication 447498 D05v01, transmitters are considered to be transmitting simultaneously when there is overlapping transmission, with the exception of transmissions during network hand-offs with maximum hand-off duration less than 30 seconds. This device contains multiple transmitters that may operate simultaneously, and therefore requires a simultaneous transmission analysis according to FCC KDB Publication 447498 D01v05 3) procedures.

**Table 1-2
Simultaneous Transmission Scenarios**

| No. | Capable Transmit Configurations | Head | Body-Worn Accessory | Hot Spot | Note |
|-----|--|-------------------------|---------------------|--------------------------------|------------|
| | | IEEE 1528, Supplement C | Supplement C | FCC KDB 941225 D06 Edges/Sides | |
| 1 | GSM 850/1900 MHz Voice + WiFi 2.4GHz | Yes | Yes | N/A | |
| 2 | 1900 UMTS Voice + WiFi 2.4GHz | Yes | Yes | N/A | |
| 3 | 850/1900 GPRS/EDGE Rx only + WIFI 2.4 GHz | N/A | N/A | Yes | 2G Hotspot |
| 4 | 1900 MHz UMTS Data + WIFI 2.4 GHz | Yes | Yes | Yes | 3G Hotspot |
| 5 | 850/1900 MHz GSM Voice + Bluetooth 2.4 GHz | N/A | Yes | N/A | |
| 6 | 1900 MHz UMTS Voice + Bluetooth 2.4 GHz | N/A | Yes | N/A | |

Notes:

1. GSM/UMTS use one modem and transceiver IC. The signals can not be transmitted simultaneously.

Notes:

1. When the user utilizes multiple services in UMTS 3G mode it uses multi-Radio Access Bearer or multi-RAB. The power control is based on a physical control channel (Dedicated Physical Control Channel [DPCCH]) and power control will be adjusted to meet the needs of both services. Therefore, the UMTS+WLAN scenario also represents the UMTS Voice/DATA + WLAN Hotspot scenario.
2. Per the manufacturer, WIFI Direct is not expected to be used in conjunction with a held-to-ear or body-worn accessory voice call. Therefore, there are no simultaneous transmission scenarios involving WIFI direct beyond that listed in the above table.



1.5 SAR Test Exclusions Applied

(A) WIFI/BT

Per FCC KDB 447498 D01v05, the SAR exclusion threshold for distances <50mm is defined by the following equation:

$$\frac{\text{Max Power of Channel (mW)}}{\text{Test Separation Dist (mm)}} * \sqrt{\text{Frequency(GHz)}} \leq 3.0$$

Based on the maximum conducted power of Bluetooth (rounded to the nearest mW) and the antenna to user separation distance, Bluetooth SAR was not required; $[(10/10) * \sqrt{2.441}] = 1.6 < 3.0$. Per KDB Publication 447498 D01v05, the maximum power of the channel was rounded to the nearest mW before calculation.

| | | | | |
|-----------------------------------|---|-------------------------------|---|---------------------------------|
| FCC ID: A3LGTS6790E |  PCTEST ENGINEERING LABORATORY, INC. | SAR EVALUATION REPORT |  | Reviewed by: Quality Manager |
| Document S/N: OY1310312083.A3L | Test Dates: 11/04/13 - 11/06/13 | DUT Type: Portable Handset | Page 5 of 35 | |

(B) Licensed Transmitter(s)

GSM/GPRS DTM is not supported for US bands. Therefore, the GSM Voice modes in this report do not transmit simultaneously with GPRS Data.

This device is only capable of QPSK HSUPA in the uplink. Therefore, no additional SAR tests are required beyond that described for devices with HSUPA in KDB 941225 D01v02.

1.6 Power Reduction for SAR

There is no power reduction used for any band/mode implemented in this device for SAR purposes.



1.7 Guidance Applied

- FCC OET Bulletin 65 Supplement C [June 2001]
- IEEE 1528-2003
- FCC KDB Publication 941225 D01-D06 (2G/3G and Hotspot)
- FCC KDB Publication 248227 D01v01r02 (SAR Considerations for 802.11 Devices)
- FCC KDB Publication 447498 D01v05 (General SAR Guidance)
- FCC KDB Publication 865664 D01-D02 (SAR Measurements up to 6 GHz)

1.8 Device Serial Numbers

Several samples were used with identical hardware to support SAR testing. The manufacturer has confirmed that the device(s) tested have the same physical, mechanical and thermal characteristics and are within operational tolerances expected for production units.

| | Head Serial Number | Body-Worn Serial Number | Hotspot Serial Number |
|----------------------------|--------------------|-------------------------|-----------------------|
| GSM/GPRS/EDGE Rx Only 850 | FK-331-A | FK-331-A | FK-331-A |
| GSM/GPRS/EDGE Rx Only 1900 | FK-331-A | FK-331-A | FK-331-A |
| UMTS 1900 | FK-331-A | FK-331-B | FK-331-B |
| 2.4 GHz WLAN | FK-331-A | FK-331-B | FK-331-B |

| | | | | |
|-----------------------------------|---|-------------------------------|---|---------------------------------|
| FCC ID: A3LGTS6790E |  | SAR EVALUATION REPORT |  | Reviewed by: Quality Manager |
| Document S/N: 0Y1310312083.A3L | Test Dates: 11/04/13 - 11/06/13 | DUT Type: Portable Handset | | Page 6 of 35 |

2 INTRODUCTION

The FCC and Industry Canada have adopted the guidelines for evaluating the environmental effects of radio frequency (RF) radiation in ET Docket 93-62 on Aug. 6, 1996 and Health Canada Safety Code 6 to protect the public and workers from the potential hazards of RF emissions due to FCC-regulated portable devices. [1]

The safety limits used for the environmental evaluation measurements are based on the criteria published by the American National Standards Institute (ANSI) for localized specific absorption rate (SAR) in IEEE/ANSI C95.1-1992 Standard for Safety Levels with Respect to Human Exposure to Radio Frequency Electromagnetic Fields, 3 kHz to 300 GHz [3] and Health Canada RF Exposure Guidelines Safety Code 6 [24]. The measurement procedure described in IEEE/ANSI C95.3-2002 Recommended Practice for the Measurement of Potentially Hazardous Electromagnetic Fields - RF and Microwave [4] is used for guidance in measuring the Specific Absorption Rate (SAR) due to the RF radiation exposure from the Equipment Under Test (EUT). These criteria for SAR evaluation are similar to those recommended by the International Committee for Non-Ionizing Radiation Protection (ICNIRP) in Biological Effects and Exposure Criteria for Radiofrequency Electromagnetic Fields," Report No. Vol 74. SAR is a measure of the rate of energy absorption due to exposure to an RF transmitting source. SAR values have been related to threshold levels for potential biological hazards.

2.1 SAR Definition

Specific Absorption Rate is defined as the time derivative (rate) of the incremental energy (dU) absorbed by (dissipated in) an incremental mass (dm) contained in a volume element (dV) of a given density (ρ). It is also defined as the rate of RF energy absorption per unit mass at a point in an absorbing body (see Equation 2-1).

Equation 2-1
SAR Mathematical Equation

$$SAR = \frac{d}{dt} \left(\frac{dU}{dm} \right) = \frac{d}{dt} \left(\frac{dU}{\rho dv} \right)$$



SAR is expressed in units of Watts per Kilogram (W/kg).

$$SAR = \frac{\sigma \cdot E^2}{\rho}$$

where:

- σ = conductivity of the tissue-simulating material (S/m)
- ρ = mass density of the tissue-simulating material (kg/m³)
- E = Total RMS electric field strength (V/m)

NOTE: The primary factors that control rate of energy absorption were found to be the wavelength of the incident field in relation to the dimensions and geometry of the irradiated organism, the orientation of the organism in relation to the polarity of field vectors, the presence of reflecting surfaces, and whether conductive contact is made by the organism with a ground plane.[6]

| | | | | |
|--|---|--------------------------------------|---|--|
| FCC ID: A3LGTS6790E |  PCTEST ENGINEERING LABORATORY, INC. | SAR EVALUATION REPORT |  | Reviewed by: Quality Manager |
| Document S/N: 0Y1310312083.A3L | Test Dates: 11/04/13 - 11/06/13 | DUT Type: Portable Handset | Page 7 of 35 | |

3 DOSIMETRIC ASSESSMENT

3.1 Measurement Procedure

The evaluation was performed using the following procedure:

1. The SAR distribution at the exposed side of the head or body was measured at a distance no greater than 5.0 mm from the inner surface of the shell. The area covered the entire dimension of the device-head and body interface and the horizontal grid resolution was determined per FCC KDB Publication 865664 D01v01 (See Table 3-1).
2. The point SAR measurement was taken at the maximum SAR region determined from Step 1 to enable the monitoring of SAR fluctuations/drifts during the 1g/10g cube evaluation. SAR at this fixed point was measured and used as a reference value.
3. Based on the area scan data, the peak of the region with maximum SAR was determined by spline interpolation. Around this point, a volume was assessed according to the measurement resolution and volume size requirements of FCC KDB Publication 865664 D01v01 (See Table 3-1). On the basis of this data set, the spatial peak SAR value was evaluated with the following procedure (see references or the DASYS manual online for more details):
 - a. The data was extrapolated to the surface of the outer-shell of the phantom. The combined distance extrapolated was the combined distance from the center of the dipoles 2.7mm away from the tip of the probe housing plus the 1.2 mm distance between the surface and the lowest measuring point. The extrapolation was based on a least-squares algorithm. A polynomial of the fourth order was calculated through the points in the z-axis (normal to the phantom shell).
 - b. After the maximum interpolated values were calculated between the points in the cube, the SAR was averaged over the spatial volume (1g or 10g) using a 3D-Spline interpolation algorithm. The 3D-spline is composed of three one-dimensional splines with the “Not a knot” condition (in x, y, and z directions). The volume was then integrated with the trapezoidal algorithm. One thousand points (10 x 10 x 10) were obtained through interpolation, in order to calculate the averaged SAR.
 - c. All neighboring volumes were evaluated until no neighboring volume with a higher average value was found.
4. The SAR reference value, at the same location as step 2, was re-measured after the zoom scan was complete to calculate the SAR drift. If the drift deviated by more than 5%, the SAR test and drift measurements were repeated.

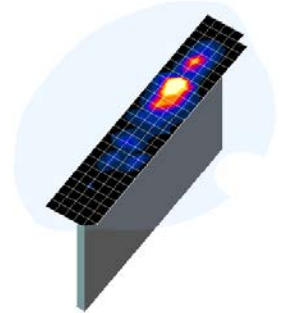



Figure 3-1
Sample SAR Area Scan

Table 3-1
Area and Zoom Scan Resolutions per FCC KDB Publication 865664 D01v01

| Frequency | Maximum Area Scan Resolution (mm) ($\Delta x_{area}, \Delta y_{area}$) | Maximum Zoom Scan Resolution (mm) ($\Delta x_{zoom}, \Delta y_{zoom}$) | Maximum Zoom Scan Spatial Resolution (mm) | | | Minimum Zoom Scan Volume (mm) (x, y, z) |
|-----------|---|---|---|------------------------|-------------------------------|--|
| | | | Uniform Grid | Graded Grid | | |
| | | | $\Delta z_{zoom}(n)$ | $\Delta z_{zoom}(1)^*$ | $\Delta z_{zoom}(n>1)^*$ | |
| ≤ 2 GHz | ≤ 15 | ≤ 8 | ≤ 5 | ≤ 4 | ≤ 1.5* $\Delta z_{zoom}(n-1)$ | ≥ 30 |
| 2-3 GHz | ≤ 12 | ≤ 5 | ≤ 5 | ≤ 4 | ≤ 1.5* $\Delta z_{zoom}(n-1)$ | ≥ 30 |
| 3-4 GHz | ≤ 12 | ≤ 5 | ≤ 4 | ≤ 3 | ≤ 1.5* $\Delta z_{zoom}(n-1)$ | ≥ 28 |
| 4-5 GHz | ≤ 10 | ≤ 4 | ≤ 3 | ≤ 2.5 | ≤ 1.5* $\Delta z_{zoom}(n-1)$ | ≥ 25 |
| 5-6 GHz | ≤ 10 | ≤ 4 | ≤ 2 | ≤ 2 | ≤ 1.5* $\Delta z_{zoom}(n-1)$ | ≥ 22 |

| | | | | |
|-----------------------------------|---|-------------------------------|---|---------------------------------|
| FCC ID: A3LGTS6790E |  | SAR EVALUATION REPORT |  | Reviewed by: Quality Manager |
| Document S/N: OY1310312083.A3L | Test Dates: 11/04/13 - 11/06/13 | DUT Type: Portable Handset | | Page 8 of 35 |

4

DEFINITION OF REFERENCE POINTS

4.1 EAR REFERENCE POINT

Figure 4-2 shows the front, back and side views of the SAM Twin Phantom. The point “M” is the reference point for the center of the mouth, “LE” is the left ear reference point (ERP), and “RE” is the right ERP. The ERP is 15mm posterior to the entrance to the ear canal (EEC) along the B-M line (Back-Mouth), as shown in Figure 4-1. The plane passing through the two ear canals and M is defined as the Reference Plane. The line N-F (Neck-Front) is perpendicular to the reference plane and passing through the RE (or LE) is called the Reference Pivoting Line (see Figure 4-1). Line B-M is perpendicular to the N-F line. Both N-F and B-M lines are marked on the external phantom shell to facilitate handset positioning [5].

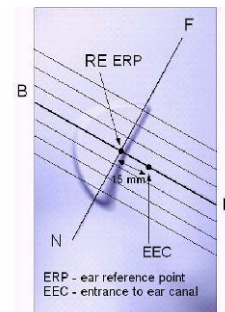

Figure 4-1
Close-Up Side view of ERP

4.2 HANDSET REFERENCE POINTS

Two imaginary lines on the handset were established: the vertical centerline and the horizontal line. The test device was placed in a normal operating position with the “test device reference point” located along the “vertical centerline” on the front of the device aligned to the “ear reference point” (See Figure 4-3). The “test device reference point” was then located at the same level as the center of the ear reference point. The test device was positioned so that the “vertical centerline” was bisecting the front surface of the handset at its top and bottom edges, positioning the “ear reference point” on the outer surface of the both the left and right head phantoms on the ear reference point.



Figure 4-2
Front, back and side view of SAM Twin Phantom

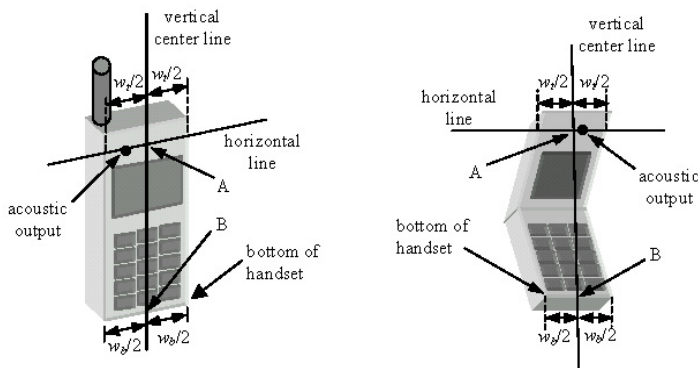



Figure 4-3
Handset Vertical Center & Horizontal Line Reference Points

| | | | | |
|-----------------------------------|---|-------------------------------|---|---------------------------------|
| FCC ID: A3LGT56790E |  | SAR EVALUATION REPORT |  | Reviewed by: Quality Manager |
| Document S/N: OY1310312083.A3L | Test Dates: 11/04/13 - 11/06/13 | DUT Type: Portable Handset | | Page 9 of 35 |

5 TEST CONFIGURATION POSITIONS FOR HANDSETS

5.1 Device Holder

The device holder is made out of low-loss POM material having the following dielectric parameters: relative permittivity $\epsilon = 3$ and loss tangent $\delta = 0.02$.

5.2 Positioning for Cheek

1. The test device was positioned with the device close to the surface of the phantom such that point A is on the (virtual) extension of the line passing through points RE and LE on the phantom (see Figure 5-1), such that the plane defined by the vertical center line and the horizontal line of the phone is approximately parallel to the sagittal plane of the phantom.

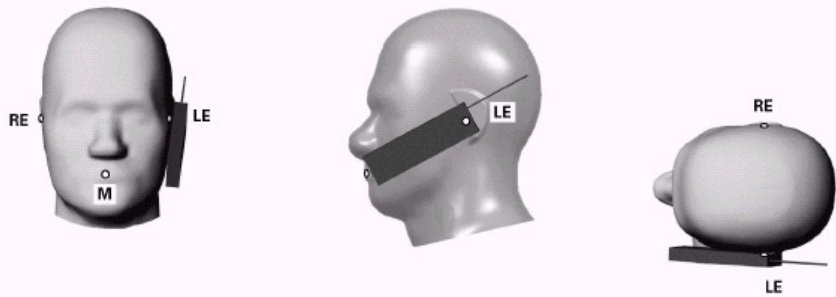



Figure 5-1 Front, Side and Top View of Cheek Position

2. The handset was translated towards the phantom along the line passing through RE & LE until the handset touches the ear.
3. While maintaining the handset in this plane, the handset was rotated around the LE-RE line until the vertical centerline was in the plane normal to MB-NF including the line MB (reference plane).
4. The phone was then rotated around the vertical centerline until the phone (horizontal line) was symmetrical with respect to the line NF.
5. While maintaining the vertical centerline in the reference plane, keeping point A on the line passing through RE and LE, and maintaining the device contact with the ear, the device was rotated about the NF line until any point on the handset made contact with a phantom point below the ear (cheek) (See Figure 5-2).

5.3 Positioning for Ear / 15° Tilt

With the test device aligned in the “Cheek Position”:

1. While maintaining the orientation of the phone, the phone was retracted parallel to the reference plane far enough to enable a rotation of the phone by 15 degrees.
2. The phone was then rotated around the horizontal line by 15 degrees.
3. While maintaining the orientation of the phone, the phone was moved parallel to the reference plane until any part of the handset touched the head. (In this position, point A was located on the line RE-LE). The tilted position is obtained when the contact is on the pinna. If the contact was at any location other than the pinna, the angle of the phone would then be reduced. The tilted position was obtained when any part of the phone was in contact of the ear as well as a second part of the phone was in contact with the head (see Figure 5-2).

| | | | | |
|-----------------------------------|---|-------------------------------|---|---------------------------------|
| FCC ID: A3LGT6790E |  | SAR EVALUATION REPORT |  | Reviewed by: Quality Manager |
| Document S/N: OY1310312083.A3L | Test Dates: 11/04/13 - 11/06/13 | DUT Type: Portable Handset | Page 10 of 35 | |

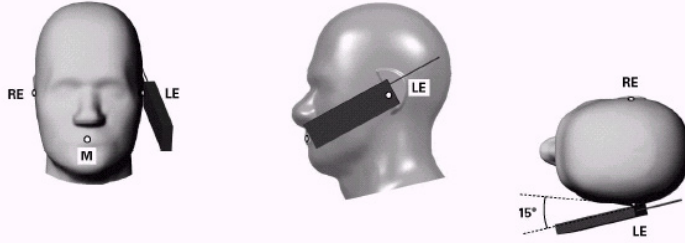

Figure 5-2 Front, Side and Top View of Ear/15° Tilt Position

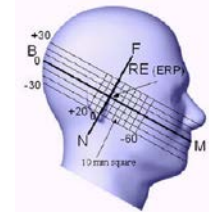

Figure 5-3 Side view w/ relevant markings

5.4 SAR Evaluations near the Mouth/Jaw Regions of the SAM Phantom

Antennas located near the bottom of a phone may require SAR measurements around the mouth and jaw regions of the SAM head phantom. This typically applies to clam-shell style phones that are generally longer in the unfolded normal use positions or to certain older style long rectangular phones.

Under these circumstances, the following procedures apply, adopted from the FCC guidance on SAR handsets document FCC KDB Publication 648474 D04_v01. The SAR required in these regions of SAM should be measured using a flat phantom. The phone should be positioned with a separation distance of 4 mm between the ear reference point (ERP) and the outer surface of the flat phantom shell. While maintaining this distance at the ERP location, the low (bottom) edge of the phone should be lowered from the phantom to establish the same separation distance between the peak SAR location identified by the truncated partial SAR distribution measured with the SAM phantom. The distance from the peak SAR location to the phone is determined by the straight line passing perpendicularly through the phantom surface. When it is not feasible to maintain 4 mm separation at the ERP while also establishing the required separation at the peak SAR location, the top edge of the phone will be allowed to touch the phantom with a separation < 4 mm at the ERP. The phone should not be tilted to the left or right while placed in this inclined position to the flat phantom.

The latest IEEE 1528 committee developments propose the usage of a tilted phantom when the antenna of the phone is mounted at the bottom or in all cases the peak absorption is in the chin region. Both SAM heads of the TwinSAM-Chin20 are rotated 20 degrees around the NF line. Each head can be removed individually from the table for emptying and cleaning.

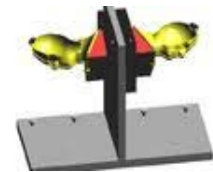



Figure 5-4 Twin SAM Chin20

| | | | | |
|-----------------------------------|---|-------------------------------|---|---------------------------------|
| FCC ID: A3LGTS6790E |  PCTEST ENGINEERING LABORATORY, INC. | SAR EVALUATION REPORT |  | Reviewed by: Quality Manager |
| Document S/N: OY1310312083.A3L | Test Dates: 11/04/13 - 11/06/13 | DUT Type: Portable Handset | | Page 11 of 35 |

5.5 Body-Worn Accessory Configurations

Body-worn operating configurations are tested with the belt-clips and holsters attached to the device and positioned against a flat phantom in a normal use configuration (see Figure 6-5). Per FCC KDB Publication 648474 D04v01, Body-worn accessory exposure is typically related to voice mode operations when handsets are carried in body-worn accessories. The body-worn accessory procedures in FCC KDB Publication 447498 D01v05 should be used to test for body-worn accessory SAR compliance, without a headset connected to it. This enables the test results for such configuration to be compatible with that required for hotspot mode when the body-worn accessory test separation distance is greater than or equal to that required for hotspot mode, when applicable. When the reported SAR for a body-worn accessory, measured without a headset connected to the handset, is $> 1.2 \text{ W/kg}$, the highest reported SAR configuration for that wireless mode and frequency band should be repeated for that body-worn accessory with a headset attached to the handset.

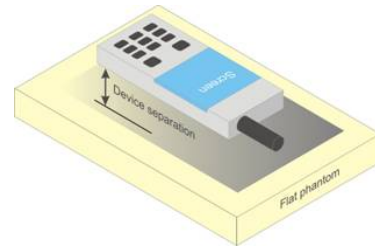

Figure 6-5
Sample Body-Worn Diagram



Accessories for Body-worn operation configurations are divided into two categories: those that do not contain metallic components and those that do contain metallic components. When multiple accessories that do not contain metallic components are supplied with the device, the device is tested with only the accessory that dictates the closest spacing to the body. Then multiple accessories that contain metallic components are tested with the device with each accessory. If multiple accessories share an identical metallic component (i.e. the same metallic belt-clip used with different holsters with no other metallic components) only the accessory that dictates the closest spacing to the body is tested.

Body-worn accessories may not always be supplied or available as options for some devices intended to be authorized for body-worn use. In this case, a test configuration with a separation distance between the back of the device and the flat phantom is used. Test position spacing was documented. Transmitters that are designed to operate in front of a person's face, as in push-to-talk configurations, are tested for SAR compliance with the front of the device positioned to face the flat phantom in head fluid. For devices that are carried next to the body such as a shoulder, waist or chest-worn transmitters, SAR compliance is tested with the accessories, including headsets and microphones, attached to the device and positioned against a flat phantom in a normal use configuration.

5.6 Extremity Exposure Configurations

Devices that are designed or intended for use on extremities or mainly operated in extremity only exposure conditions; i.e., hands, wrists, feet and ankles, may require extremity SAR evaluation. When the device also operates in close proximity to the user's body, SAR compliance for the body is also required. The 1-g body and 10-g extremity SAR Exclusion Thresholds found in KDB Publication 44798 D01v05 should be applied to determine SAR test requirements.



Per KDB Publication 44798 D01v05, Cell phones (handsets) are not normally designed to be used on extremities or operated in extremity only exposure conditions. The maximum output power levels of handsets generally do not require extremity SAR testing to show compliance. Therefore, extremity SAR was not evaluated for this device.

| | | | | |
|-----------------------------------|---|-------------------------------|---|---------------------------------|
| FCC ID: A3LGT6790E |  | SAR EVALUATION REPORT |  | Reviewed by: Quality Manager |
| Document S/N: 0Y1310312083.A3L | Test Dates: 11/04/13 - 11/06/13 | DUT Type: Portable Handset | Page 12 of 35 | |

5.7 Wireless Router Configurations

Some battery-operated handsets have the capability to transmit and receive user data through simultaneous transmission of WIFI simultaneously with a separate licensed transmitter. The FCC has provided guidance in FCC KDB Publication 941225 D06 v01 where SAR test considerations for handsets ($L \times W \geq 9 \text{ cm} \times 5 \text{ cm}$) are based on a composite test separation distance of 10 mm from the front, back and edges of the device containing transmitting antennas within 2.5 cm of their edges, determined from general mixed use conditions for this type of devices. Since the hotspot SAR results may overlap with the body-worn accessory SAR requirements, the more conservative configurations can be considered, thus excluding some body-worn accessory SAR tests.

When the user enables the personal wireless router functions for the handset, actual operations include simultaneous transmission of both the WIFI transmitter and another licensed transmitter. Both transmitters often do not transmit at the same transmitting frequency and thus cannot be evaluated for SAR under actual use conditions due to the limitations of the SAR assessment probes. Therefore, SAR must be evaluated for each frequency transmission and mode separately and spatially summed with the WIFI transmitter according to FCC KDB Publication 447498 D01v05 publication procedures. The "Portable Hotspot" feature on the handset was NOT activated during SAR assessments, to ensure the SAR measurements were evaluated for a single transmission frequency RF signal at a time.

| | | | | |
|-----------------------------------|---|-------------------------------|---|---------------------------------|
| FCC ID: A3LGTS6790E |  | SAR EVALUATION REPORT |  | Reviewed by: Quality Manager |
| Document S/N: 0Y1310312083.A3L | Test Dates: 11/04/13 - 11/06/13 | DUT Type: Portable Handset | | Page 13 of 35 |

6 RF EXPOSURE LIMITS

6.1 Uncontrolled Environment

UNCONTROLLED ENVIRONMENTS are defined as locations where there is the exposure of individuals who have no knowledge or control of their exposure. The general population/uncontrolled exposure limits are applicable to situations in which the general public may be exposed or in which persons who are exposed as a consequence of their employment may not be made fully aware of the potential for exposure or cannot exercise control over their exposure. Members of the general public would come under this category when exposure is not employment-related; for example, in the case of a wireless transmitter that exposes persons in its vicinity.



6.2 Controlled Environment

CONTROLLED ENVIRONMENTS are defined as locations where there is exposure that may be incurred by persons who are aware of the potential for exposure, (i.e. as a result of employment or occupation). In general, occupational/controlled exposure limits are applicable to situations in which persons are exposed as a consequence of their employment, who have been made fully aware of the potential for exposure and can exercise control over their exposure. This exposure category is also applicable when the exposure is of a transient nature due to incidental passage through a location where the exposure levels may be higher than the general population/uncontrolled limits, but the exposed person is fully aware of the potential for exposure and can exercise control over his or her exposure by leaving the area or by some other appropriate means.

Table 6-1
SAR Human Exposure Specified in ANSI/IEEE C95.1-1992 and Health Canada Safety Code 6

| HUMAN EXPOSURE LIMITS | | |
|---|---|---|
| | UNCONTROLLED ENVIRONMENT <i>General Population</i> (W/kg) or (mW/g) | CONTROLLED ENVIRONMENT <i>Occupational</i> (W/kg) or (mW/g) |
| Peak Spatial Average SAR Head | 1.6 | 8.0 |
| Whole Body SAR | 0.08 | 0.4 |
| Peak Spatial Average SAR Hands, Feet, Ankle, Wrists, etc. | 4.0 | 20 |

1. The Spatial Peak value of the SAR averaged over any 1 gram of tissue (defined as a tissue volume in the shape of a cube) and over the appropriate averaging time.
2. The Spatial Average value of the SAR averaged over the whole body.
3. The Spatial Peak value of the SAR averaged over any 10 grams of tissue (defined as a tissue volume in the shape of a cube) and over the appropriate averaging time.

| | | | | |
|-----------------------------------|---|-------------------------------|---|---------------------------------|
| FCC ID: A3LGTS6790E |  | SAR EVALUATION REPORT |  | Reviewed by: Quality Manager |
| Document S/N: OY1310312083.A3L | Test Dates: 11/04/13 - 11/06/13 | DUT Type: Portable Handset | Page 14 of 35 | |

7 FCC MEASUREMENT PROCEDURES

Power measurements were performed using a base station simulator under digital average power.

7.1 Measured and Reported SAR

Per FCC KDB Publication 447498 D01v05, When SAR is not measured at the maximum power level allowed for production units, the results must be scaled to the maximum tune-up tolerance limit according to the power applied to the individual channels tested to determine compliance. For simultaneous transmission, the measured aggregate SAR must be scaled according to the sum of the differences between the maximum tune-up tolerance and actual power used to test each transmitter. When SAR is measured at or scaled to the maximum tune-up tolerance limit, the results are referred to as *reported* SAR. The highest *reported* SAR results are identified on the grant of equipment authorization according to procedures in KDB 690783 D01v01r02.

7.2 Procedures Used to Establish RF Signal for SAR

The following procedures are according to FCC KDB Publication 941225 D01 "SAR Measurement Procedures for 3G Devices" v02, October 2007.

The device was placed into a simulated call using a base station simulator in a RF shielded chamber. Establishing connections in this manner ensure a consistent means for testing SAR and are recommended for evaluating SAR [4]. Devices under test were evaluated prior to testing, with a fully charged battery and were configured to operate at maximum output power. In order to verify that the device was tested throughout the SAR test at maximum output power, the SAR measurement system measures a "point SAR" at an arbitrary reference point at the start and end of the 1 gram SAR evaluation, to assess for any power drifts during the evaluation. If the power drift deviated by more than 5%, the SAR test and drift measurements were repeated.

7.3 SAR Measurement Conditions for UMTS



7.3.1 Output Power Verification

Maximum output power is measured on the High, Middle and Low channels for each applicable transmission band according to the general descriptions in section 5.2 of 3GPP TS 34.121, using the appropriate RMC or AMR with TPC (transmit power control) set to all "1s".

Maximum output power is verified on the High, Middle and Low channels according to the general descriptions in section 5.2 of 3GPP TS 34.121 (release 5), using the appropriate RMC with TPC (transmit power control) set to all "1s" or applying the required inner loop power control procedures to maintain maximum output power while HSUPA is active. Results for all applicable physical channel configurations (DPCCH, DPDCHn and spreading codes, HS-DPCCH etc) are tabulated in this test report. All configurations that are not supported by the DUT or cannot be measured due to technical or equipment limitations are identified.

7.3.2 Head SAR Measurements for Handsets

SAR for head exposure configurations is measured using the 12.2 kbps RMC with TPC bits configured to all "1s". SAR in AMR configurations is not required when the maximum average output of each RF channel for 12.2 kbps AMR is less than 0.25 dB higher than that measured in 12.2 kbps RMC. Otherwise, SAR is measured on the maximum output channel in 12.2 AMR with a

| | | | | |
|-----------------------------------|---|-------------------------------|---|---------------------------------|
| FCC ID: A3LGTS6790E |  | SAR EVALUATION REPORT |  | Reviewed by: Quality Manager |
| Document S/N: OY1310312083.A3L | Test Dates: 11/04/13 - 11/06/13 | DUT Type: Portable Handset | | Page 15 of 35 |

3.4 kbps SRB (signaling radio bearer) using the exposure configuration that resulted in the highest SAR for that RF channel in the 12.2 kbps RMC mode.

7.3.3 Body SAR Measurements

SAR for body exposure configurations is measured using the 12.2 kbps RMC with the TPC bits all “1s”.

7.3.4 SAR Measurements for Handsets with Rel 5 HSDPA

Body SAR for HSDPA is not required for handsets with HSDPA capabilities when the maximum average output power of each RF channel with HSDPA active is less than 0.25 dB higher than that measured without HSDPA using 12.2 kbps RMC and the maximum SAR for 12.2 kbps RMC is $\leq 75\%$ of the SAR limit. Otherwise, SAR is measured for HSDPA, using an FRC with H-Set 1 in Sub-test 1 and a 12.2 kbps RMC configured in Test Loop Mode 1, using the highest body SAR configuration measured in 12.2 kbps RMC without HSDPA, on the maximum output channel with the body exposure configuration that resulted in the highest SAR in 12.2 kbps RMC mode for that RF channel.

The H-set used in FRC for HSDPA should be configured according to the UE category of a test device. The number of HS-DSCH/HSPDSCHs, HARQ processes, minimum inter-TTI interval, transport block sizes and RV coding sequence are defined by the applicable H-set. To maintain a consistent test configuration and stable transmission conditions, QPSK is used in the FRC for SAR testing. HS-DPCCH should be configured with a CQI feedback cycle of 2 ms to maintain a constant rate of active CQI slots. DPCCH and DPDCH gain factors of $\beta_c=9$ and $\beta_d=15$, and power offset parameters of $\Delta_{ACK} = \Delta_{NACK} = 5$ and $\Delta_{CQI}=2$ is used. The CQI value is determined by the UE category, transport block size, number of HS-PDSCHs and modulation used in the FRC.



| Sub-Test | β_c | β_d | β_d (SF) | β_c/β_d | β_{HS} (Note 1, Note 2) | CM (dB) (Note 3) | MPR (dB) (Note 3) |
|----------|-------------------|-------------------|-------------------|-------------------|-------------------------------------|---------------------|----------------------|
| 1 | 2/15 | 15/15 | 64 | 2/15 | 4/15 | 0.0 | 0.0 |
| 2 | 12/15 (Note 4) | 15/15 (Note 4) | 64 | 12/15 (Note 4) | 24/15 | 1.0 | 0.0 |
| 3 | 15/15 | 8/15 | 64 | 15/8 | 30/15 | 1.5 | 0.5 |
| 4 | 15/15 | 4/15 | 64 | 15/4 | 30/15 | 1.5 | 0.5 |

Note 1: $\Delta_{ACK}, \Delta_{NACK}$ and $\Delta_{CQI} = 8 \Leftrightarrow A_{HS} = \beta_{HS}/\beta_c = 30/15 \Leftrightarrow \beta_{HS} = 30/15 * \beta_c$.
 Note 2: For the HS-DPCCH power mask requirement test in clause 5.2C, 5.7A, and the Error Vector Magnitude (EVM) with HS-DPCCH test in clause 5.13.1A, and HSDPA EVM with phase discontinuity in clause 5.13.1AA, Δ_{ACK} and $\Delta_{NACK} = 8$ ($A_{HS} = 30/15$) with $\beta_{HS} = 30/15 * \beta_c$, and $\Delta_{CQI} = 7$ ($A_{HS} = 24/15$) with $\beta_{HS} = 24/15 * \beta_c$.
 Note 3: CM = 1 for $\beta_c/\beta_d = 12/15$, $\beta_{HS}/\beta_c = 24/15$. For all other combinations of DPDCH, DPCCH and HS-DPCCH the MPR is based on the relative CM difference. This is applicable for only UEs that support HSDPA in release 6 and later releases.

Figure 7-1
Table C.10.1.4 of TS 234.121-1

7.3.5 SAR Measurements for Handsets with Rel 6 HSUPA

Body SAR for HSUPA is not required when the maximum average output of each RF channel with HSUPA/HSDPA active is less than 0.25 dB higher than as measured without HSUPA/HSDPA using 12.2 kbps RMC and maximum SAR for 12.2 kbps RMC is $\leq 75\%$ of the SAR limit. Otherwise SAR is measured on the maximum output channel for the body exposure configuration produced highest SAR in 12.2 kbps RMC for that RF channel, using the additional procedures under “Release 6 HSPA data devices”

| | | | | |
|-----------------------------------|---|-------------------------------|---|---------------------------------|
| FCC ID: A3LGT56790E |  | SAR EVALUATION REPORT |  | Reviewed by: Quality Manager |
| Document S/N: OY1310312083.A3L | Test Dates: 11/04/13 - 11/06/13 | DUT Type: Portable Handset | Page 16 of 35 | |

Head SAR for VOIP operations under HSPA is not required when maximum average output of each RF channel with HSPA is less than 0.25 dB higher than as measured using 12.2 kbps RMC. Otherwise SAR is measured using same HSPA configuration as used for body SAR.

| Sub-test | β_c | β_d | β_d (SF) | β_c/β_d | $\beta_{is}^{(1)}$ | β_{ec} | β_{ed} | β_{ed} (SF) | β_{ed} (codes) | CM ⁽²⁾ (dB) | MPR (dB) | AG ⁽⁴⁾ Index | E-TFCI |
|----------|----------------------|----------------------|----------------|----------------------|--------------------|--------------|--|-------------------|----------------------|------------------------|----------|-------------------------|--------|
| 1 | 11/15 ⁽³⁾ | 15/15 ⁽³⁾ | 64 | 11/15 ⁽³⁾ | 22/15 | 209/225 | 1039/225 | 4 | 1 | 1.0 | 0.0 | 20 | 75 |
| 2 | 6/15 | 15/15 | 64 | 6/15 | 12/15 | 12/15 | 94/75 | 4 | 1 | 3.0 | 2.0 | 12 | 67 |
| 3 | 15/15 | 9/15 | 64 | 15/9 | 30/15 | 30/15 | $\beta_{ed1}: 47/15$ $\beta_{ed2}: 47/15$ | 4 | 2 | 2.0 | 1.0 | 15 | 92 |
| 4 | 2/15 | 15/15 | 64 | 2/15 | 4/15 | 2/15 | 56/75 | 4 | 1 | 3.0 | 2.0 | 17 | 71 |
| 5 | 15/15 ⁽⁴⁾ | 15/15 ⁽⁴⁾ | 64 | 15/15 ⁽⁴⁾ | 30/15 | 24/15 | 134/15 | 4 | 1 | 1.0 | 0.0 | 21 | 81 |

Note 1: Δ_{ACK} , Δ_{NACK} and $\Delta_{CQI} = 8 \Leftrightarrow A_{is} = \beta_{is}/\beta_c = 30/15 \Leftrightarrow \beta_{is} = 30/15 * \beta_c$.
 Note 2: CM = 1 for $\beta_c/\beta_d = 12/15$, $\beta_{is}/\beta_c = 24/15$. For all other combinations of DPDCH, DPCCCH, HS-DPCCH, E-DPDCH and E-DPCCH the MPR is based on the relative CM difference.
 Note 3: For subtest 1 the β_c/β_d ratio of 11/15 for the TFC during the measurement period (TF1, TF0) is achieved by setting the signaled gain factors for the reference TFC (TF1, TF1) to $\beta_c = 10/15$ and $\beta_d = 15/15$.
 Note 4: For subtest 5 the β_c/β_d ratio of 15/15 for the TFC during the measurement period (TF1, TF0) is achieved by setting the signaled gain factors for the reference TFC (TF1, TF1) to $\beta_c = 14/15$ and $\beta_d = 15/15$.
 Note 5: Testing UE using E-DPDCH Physical Layer category 1 Sub-test 3 is not required according to TS 25.306 Table 5.1g.
 Note 6: β_{ed} can not be set directly; it is set by Absolute Grant Value.

7.4 SAR Testing with 802.11 Transmitters

Normal network operating configurations are not suitable for measuring the SAR of 802.11 b/g/n transmitters. Unpredictable fluctuations in network traffic and antenna diversity conditions can introduce undesirable variations in SAR results. The SAR for these devices should be measured using chipset based test mode software to ensure the results are consistent and reliable. See KDB Publication 248227 D01v01r02 for more details.



7.4.1 General Device Setup

Chipset based test mode software is hardware dependent and generally varies among manufacturers. The device operating parameters established in test mode for SAR measurements must be identical to those programmed in production units, including output power levels, amplifier gain settings and other RF performance tuning parameters. The test frequencies should correspond to actual channel frequencies defined for domestic use. SAR for devices with switched diversity should be measured with only one antenna transmitting at a time during each SAR measurement, according to a fixed modulation and data rate. The same data pattern should be used for all measurements.

7.4.2 Frequency Channel Configurations [27]

For 2.4 GHz, the highest average RF output power channel between the low, mid and high channel at the lowest data rate was selected for SAR evaluation in 802.11b mode. 802.11g/n modes and higher data rates for 802.11b were not evaluated for SAR since the output power of the respective mode was not 0.25 dB or higher than the powers of the SAR configurations tested in the 802.11b mode.

Since the maximum extrapolated peak SAR of the zoom scan for the highest output channel was less than 1.6 W/kg and the 1g averaged SAR was less than 0.8 W/kg, SAR testing was not required for the other test channels in the band.

| | | | | |
|-----------------------------------|---|-------------------------------|---|---------------------------------|
| FCC ID: A3LGTS6790E |  | SAR EVALUATION REPORT |  | Reviewed by: Quality Manager |
| Document S/N: OY1310312083.A3L | Test Dates: 11/04/13 - 11/06/13 | DUT Type: Portable Handset | Page 17 of 35 | |

8 RF CONDUCTED POWERS

8.1 GSM Conducted Powers

| | | Maximum Burst-Averaged Output Power | | | | |
|-----------------|---------|-------------------------------------|----------------------------|----------------------------|----------------------------|----------------------------|
| | | Voice | GPRS Data (GMSK) | | | |
| Band | Channel | GSM [dBm] CS (1 Slot) | GPRS [dBm] 1 Tx Slot | GPRS [dBm] 2 Tx Slot | GPRS [dBm] 3 Tx Slot | GPRS [dBm] 4 Tx Slot |
| GSM 850 | 128 | 32.48 | 32.46 | 29.98 | 27.92 | 26.89 |
| | 190 | 32.49 | 32.46 | 29.99 | 27.93 | 26.92 |
| | 251 | 32.35 | 32.30 | 29.84 | 27.82 | 26.82 |
| GSM 1900 | 512 | 28.92 | 28.92 | 27.03 | 25.06 | 24.05 |
| | 661 | 29.01 | 29.03 | 27.12 | 25.19 | 24.20 |
| | 810 | 29.00 | 28.99 | 27.28 | 25.30 | 24.34 |

| | | Calculated Maximum Frame-Averaged Output Power | | | | |
|-----------------|---------|--|----------------------------|----------------------------|----------------------------|----------------------------|
| | | Voice | GPRS Data (GMSK) | | | |
| Band | Channel | GSM [dBm] CS (1 Slot) | GPRS [dBm] 1 Tx Slot | GPRS [dBm] 2 Tx Slot | GPRS [dBm] 3 Tx Slot | GPRS [dBm] 4 Tx Slot |
| GSM 850 | 128 | 23.45 | 23.43 | 23.96 | 23.66 | 23.88 |
| | 190 | 23.46 | 23.43 | 23.97 | 23.67 | 23.91 |
| | 251 | 23.32 | 23.27 | 23.82 | 23.56 | 23.81 |
| GSM 1900 | 512 | 19.89 | 19.89 | 21.01 | 20.80 | 21.04 |
| | 661 | 19.98 | 20.00 | 21.10 | 20.93 | 21.19 |
| | 810 | 19.97 | 19.96 | 21.26 | 21.04 | 21.33 |

Note:

- Both burst-averaged and calculated frame-averaged powers are included. Frame-averaged power was calculated from the measured burst-averaged power by converting the slot powers into linear units and calculating the energy over 8 timeslots.
- The bolded GPRS modes were selected for SAR testing according to KDB 941225 D03v01 and October 2013 TCB Workshop Notes. The configuration with the highest target frame averaged power was evaluated for SAR. When the maximum frame averaged power is equivalent across slot configurations (within 0.25 dB), the configuration with the greatest number of slots is tested.
- GPRS (GMSK) output powers were measured with coding scheme setting of 1 (CS1) on the base station simulator. CS1 was configured to measure GPRS output power measurements and SAR to ensure GMSK modulation in the signal. Our Investigation has shown that CS1 - CS4 settings do not have any impact on the output levels or modulation in the GPRS modes.

GSM Class: B
GPRS Multislot class: 12 (Max 4 Tx uplink slots)
EDGE Multislot class: Rx Only
DTM Multislot Class: N/A

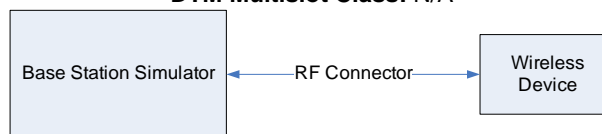



Figure 8-1
Power Measurement Setup

| | | | | |
|-----------------------------------|---|-------------------------------|---|---------------------------------|
| FCC ID: A3LGTS6790E |  | SAR EVALUATION REPORT |  | Reviewed by: Quality Manager |
| Document S/N: OY1310312083.A3L | Test Dates: 11/04/13 - 11/06/13 | DUT Type: Portable Handset | Page 18 of 35 | |

8.2 UMTS Conducted Powers

| 3GPP Release Version | Mode | 3GPP 34.121 Subtest | PCS Band [dBm] | | | 3GPP MPR [dB] |
|----------------------|-------|---------------------|----------------|-------|-------|---------------|
| | | | 9262 | 9400 | 9538 | |
| 99 | WCDMA | 12.2 kbps RMC | 22.81 | 22.94 | 23.00 | - |
| 99 | | 12.2 kbps AMR | 22.93 | 22.91 | 22.97 | - |
| 6 | HSDPA | Subtest 1 | 22.93 | 23.00 | 22.97 | 0 |
| 6 | | Subtest 2 | 22.20 | 22.10 | 22.25 | 0 |
| 6 | | Subtest 3 | 22.06 | 21.97 | 22.11 | 0.5 |
| 6 | | Subtest 4 | 22.02 | 21.90 | 22.11 | 0.5 |
| 6 | HSUPA | Subtest 1 | 21.07 | 21.03 | 21.19 | 0 |
| 6 | | Subtest 2 | 19.77 | 19.52 | 19.68 | 2 |
| 6 | | Subtest 3 | 20.69 | 20.73 | 20.79 | 1 |
| 6 | | Subtest 4 | 20.07 | 19.81 | 20.03 | 2 |
| 6 | | Subtest 5 | 21.30 | 21.16 | 21.24 | 0 |



UMTS SAR was tested under RMC 12.2 kbps with HSPA Inactive per KDB Publication 941225 D01v02. HSPA SAR was not required since the average output power of the HSPA subtests was not more than 0.25 dB higher than the RMC level and SAR was less than 1.2 W/kg.

This device does not support DC-HSDPA.

It is expected by the manufacturer that MPR for some HSUPA subtests may be as low as 0 dB according to the chipset implementation in this model.



Figure 8-2
Power Measurement Setup

| | | | | |
|-----------------------------------|---|-------------------------------|---|---------------------------------|
| FCC ID: A3LGTS6790E |  | SAR EVALUATION REPORT |  | Reviewed by: Quality Manager |
| Document S/N: OY1310312083.A3L | Test Dates: 11/04/13 - 11/06/13 | DUT Type: Portable Handset | Page 19 of 35 | |

8.3 WLAN Conducted Powers

Table 8-1
IEEE 802.11b Average RF Power

| Mode | Freq | Channel | 802.11b (2.4 GHz) Conducted Power [dBm] | | | |
|---------|-------|---------|---|-------|-------|-------|
| | | | Data Rate [Mbps] | | | |
| | [MHz] | 1 | 2 | 5.5 | 11 | |
| 802.11b | 2412 | 1 | 14.84 | 14.86 | 15.20 | 15.00 |
| 802.11b | 2437 | 6 | 15.06 | 14.95 | 15.44 | 15.20 |
| 802.11b | 2462 | 11 | 15.20 | 15.24 | 14.65 | 14.52 |

Table 8-2
IEEE 802.11g Average RF Power

| Mode | Freq | Channel | 802.11g (2.4 GHz) Conducted Power [dBm] | | | | | | | |
|---------|-------|---------|---|-------|-------|-------|-------|-------|-------|-------|
| | | | Data Rate [Mbps] | | | | | | | |
| | [MHz] | 6 | 9 | 12 | 18 | 24 | 36 | 48 | 54 | |
| 802.11g | 2412 | 1 | 10.63 | 10.74 | 10.55 | 10.82 | 10.90 | 10.73 | 10.67 | 10.63 |
| 802.11g | 2437 | 6 | 10.96 | 10.98 | 11.01 | 10.92 | 10.96 | 10.99 | 10.98 | 10.99 |
| 802.11g | 2462 | 11 | 11.20 | 11.19 | 11.13 | 11.11 | 11.24 | 11.15 | 11.13 | 11.17 |

Table 8-3
IEEE 802.11n Average RF Power

| Mode | Freq | Channel | 802.11n (2.4 GHz) Conducted Power [dBm] | | | | | | | |
|---------|-------|---------|---|------|------|------|------|------|------|------|
| | | | Data Rate [Mbps] | | | | | | | |
| | [MHz] | 6.5 | 13 | 20 | 26 | 39 | 52 | 58 | 65 | |
| 802.11n | 2412 | 1 | 7.58 | 7.55 | 7.56 | 7.48 | 7.43 | 7.17 | 7.52 | 7.43 |
| 802.11n | 2437 | 6 | 7.77 | 7.81 | 7.79 | 7.82 | 7.77 | 7.62 | 7.58 | 7.68 |
| 802.11n | 2462 | 11 | 7.95 | 8.03 | 8.07 | 7.94 | 7.91 | 8.08 | 7.95 | 7.85 |

Justification for reduced test configurations for WIFI channels per KDB Publication 248227 D01v01r02 and October 2012/April 2013 FCC/TCB Meeting Notes:

- For 2.4 GHz, highest average RF output power channel for the lowest data rate for IEEE 802.11b were selected for SAR evaluation. Other IEEE 802.11 modes (including 802.11g/n) were not investigated since the average output powers over all channels and data rates were not more than 0.25 dB higher than the tested channel in the lowest data rate of IEEE 802.11b mode.
- The maximum extrapolated peak SAR of the zoom scan for the maximum output channel is <1.6 W/kg and the reported 1g averaged SAR is <0.8 W/kg; therefore, SAR testing on other channels is not required.
- The bolded data rate and channel above were tested for SAR.

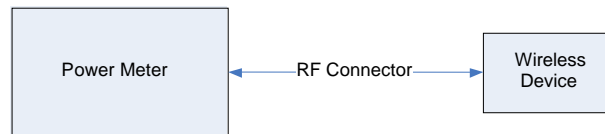



Figure 8-3
Power Measurement Setup

| | | | | |
|-----------------------------------|---|-------------------------------|---|---------------------------------|
| FCC ID: A3LGT56790E |  | SAR EVALUATION REPORT |  | Reviewed by: Quality Manager |
| Document S/N: OY1310312083.A3L | Test Dates: 11/04/13 - 11/06/13 | DUT Type: Portable Handset | Page 20 of 35 | |



9 SYSTEM VERIFICATION

9.1 Tissue Verification

**Table 9-1
Measured Tissue Properties**

| Calibrated for Tests Performed on: | Tissue Type | Tissue Temp During Calibration (C°) | Measured Frequency (MHz) | Measured Conductivity, σ (S/m) | Measured Dielectric Constant, ϵ | TARGET Conductivity, σ (S/m) | TARGET Dielectric Constant, ϵ | % dev σ | % dev ϵ |
|------------------------------------|-------------|-------------------------------------|--------------------------|---------------------------------------|--|-------------------------------------|--|----------------|------------------|
| 11/04/2013 | 835H | 21.6 | 820 | 0.903 | 41.318 | 0.899 | 41.578 | 0.44% | -0.63% |
| | | | 835 | 0.917 | 41.142 | 0.900 | 41.500 | 1.89% | -0.86% |
| | | | 850 | 0.933 | 40.862 | 0.916 | 41.500 | 1.86% | -1.54% |
| 11/06/2013 | 1900H | 22.8 | 1850 | 1.395 | 40.080 | 1.400 | 40.000 | -0.36% | 0.20% |
| | | | 1880 | 1.426 | 39.937 | 1.400 | 40.000 | 1.86% | -0.16% |
| | | | 1910 | 1.456 | 39.809 | 1.400 | 40.000 | 4.00% | -0.48% |
| 11/04/2013 | 2450H | 20.9 | 2401 | 1.767 | 40.988 | 1.756 | 39.287 | 0.63% | 4.33% |
| | | | 2450 | 1.824 | 40.815 | 1.800 | 39.200 | 1.33% | 4.12% |
| | | | 2499 | 1.879 | 40.640 | 1.853 | 39.138 | 1.40% | 3.84% |
| 11/04/2013 | 835B | 21.0 | 820 | 0.987 | 53.906 | 0.969 | 55.258 | 1.86% | -2.45% |
| | | | 835 | 0.999 | 53.709 | 0.970 | 55.200 | 2.99% | -2.70% |
| | | | 850 | 1.015 | 53.588 | 0.988 | 55.154 | 2.73% | -2.84% |
| 11/04/2013 | 1900B | 22.3 | 1850 | 1.480 | 52.503 | 1.520 | 53.300 | -2.63% | -1.50% |
| | | | 1880 | 1.512 | 52.414 | 1.520 | 53.300 | -0.53% | -1.66% |
| | | | 1910 | 1.548 | 52.328 | 1.520 | 53.300 | 1.84% | -1.82% |
| 11/04/2013 | 2450B | 22.4 | 2401 | 1.887 | 53.212 | 1.903 | 52.765 | -0.84% | 0.85% |
| | | | 2450 | 1.954 | 53.068 | 1.950 | 52.700 | 0.21% | 0.70% |
| | | | 2499 | 2.017 | 52.899 | 2.019 | 52.638 | -0.10% | 0.50% |

The above measured tissue parameters were used in the DASY software. The DASY software was used to perform interpolation to determine the dielectric parameters at the SAR test device frequencies (per IEEE 1528 6.6.1.2). The tissue parameters listed in the SAR test plots may slightly differ from the table above due to significant digit rounding in the software.

| | | | | |
|-----------------------------------|---|-------------------------------|---|---------------------------------|
| FCC ID: A3LGTS6790E |  | SAR EVALUATION REPORT |  | Reviewed by: Quality Manager |
| Document S/N: OY1310312083.A3L | Test Dates: 11/04/13 - 11/06/13 | DUT Type: Portable Handset | | Page 21 of 35 |

9.2 Test System Verification

Prior to SAR assessment, the system is verified to $\pm 10\%$ of the SAR measurement on the reference dipole at the time of calibration by the calibration facility. Full system validation status and result summary can be found in Appendix E.

Table 9-2
System Verification Results

| System Verification TARGET & MEASURED | | | | | | | | | | | | |
|--|------------------------|-------------|------------|----------------|------------------|-----------------|-----------|----------|-----------------------------------|-------------------------------------|---|-----------------------------|
| SAR System # | Tissue Frequency (MHz) | Tissue Type | Date: | Amb. Temp (°C) | Liquid Temp (°C) | Input Power (W) | Dipole SN | Probe SN | Measured SAR _{1g} (W/kg) | 1 W Target SAR _{1g} (W/kg) | 1 W Normalized SAR _{1g} (W/kg) | Deviation _{1g} (%) |
| D | 835 | HEAD | 11/04/2013 | 21.9 | 21.6 | 0.100 | 4d119 | 3022 | 0.988 | 9.680 | 9.880 | 2.07% |
| G | 1900 | HEAD | 11/06/2013 | 24.5 | 23.0 | 0.100 | 5d148 | 3209 | 4.000 | 39.700 | 40.000 | 0.76% |
| G | 2450 | HEAD | 11/04/2013 | 21.3 | 20.9 | 0.040 | 797 | 3209 | 2.060 | 52.500 | 51.500 | -1.90% |
| H | 835 | BODY | 11/04/2013 | 21.7 | 21.0 | 0.100 | 4d119 | 3318 | 0.997 | 9.540 | 9.970 | 4.51% |
| I | 1900 | BODY | 11/04/2013 | 23.4 | 22.3 | 0.100 | 5d148 | 3319 | 3.890 | 40.800 | 38.900 | -4.66% |
| C | 2450 | BODY | 11/04/2013 | 22.3 | 22.4 | 0.100 | 882 | 3263 | 4.940 | 49.900 | 49.400 | -1.00% |

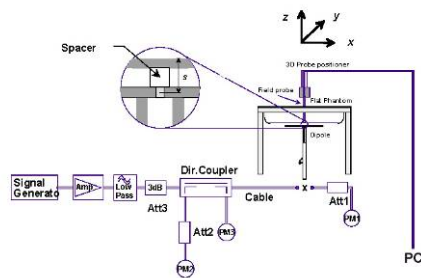



Figure 9-1
System Verification Setup Diagram



Figure 9-2
System Verification Setup Photo

| | | | | |
|-----------------------------------|---|-------------------------------|---|---------------------------------|
| FCC ID: A3LGTS6790E |  | SAR EVALUATION REPORT |  | Reviewed by: Quality Manager |
| Document S/N: OY1310312083.A3L | Test Dates: 11/04/13 - 11/06/13 | DUT Type: Portable Handset | Page 22 of 35 | |

10 SAR DATA SUMMARY

10.1 Standalone Head SAR Data

**Table 10-1
GSM 850 Head SAR**

| MEASUREMENT RESULTS | | | | | | | | | | | | | | |
|---|-----|-----------|---------|-----------------------------|-----------------------|------------------|-------|---|----------------------|------------|----------|----------------|-----------------|--------|
| FREQUENCY | | Mode/Band | Service | Maximum Allowed Power [dBm] | Conducted Power [dBm] | Power Drift [dB] | Side | Test Position | Device Serial Number | Duty Cycle | SAR (1g) | Scaling Factor | Scaled SAR (1g) | Plot # |
| MHz | Ch. | | | | | | | | | | (W/kg) | | (W/kg) | |
| 836.60 | 190 | GSM 850 | GSM | 33.0 | 32.49 | 0.01 | Right | Cheek | FK-331-A | 1:8.3 | 0.302 | 1.125 | 0.340 | |
| 836.60 | 190 | GSM 850 | GSM | 33.0 | 32.49 | 0.09 | Right | Tilt | FK-331-A | 1:8.3 | 0.200 | 1.125 | 0.225 | |
| 836.60 | 190 | GSM 850 | GSM | 33.0 | 32.49 | 0.02 | Left | Cheek | FK-331-A | 1:8.3 | 0.353 | 1.125 | 0.397 | A1 |
| 836.60 | 190 | GSM 850 | GSM | 33.0 | 32.49 | 0.02 | Left | Tilt | FK-331-A | 1:8.3 | 0.188 | 1.125 | 0.212 | |
| ANSI / IEEE C95.1 1992 - SAFETY LIMIT Spatial Peak Uncontrolled Exposure/General Population | | | | | | | | Head 1.6 W/kg (mW/g) averaged over 1 gram | | | | | | |

**Table 10-2
GSM 1900 Head SAR**



| MEASUREMENT RESULTS | | | | | | | | | | | | | | |
|---|-----|-----------|---------|-----------------------------|-----------------------|------------------|-------|---|----------------------|------------|----------|----------------|-----------------|--------|
| FREQUENCY | | Mode/Band | Service | Maximum Allowed Power [dBm] | Conducted Power [dBm] | Power Drift [dB] | Side | Test Position | Device Serial Number | Duty Cycle | SAR (1g) | Scaling Factor | Scaled SAR (1g) | Plot # |
| MHz | Ch. | | | | | | | | | | (W/kg) | | (W/kg) | |
| 1880.00 | 661 | GSM 1900 | GSM | 29.5 | 29.01 | 0.04 | Right | Cheek | FK-331-A | 1:8.3 | 0.268 | 1.119 | 0.300 | |
| 1880.00 | 661 | GSM 1900 | GSM | 29.5 | 29.01 | -0.06 | Right | Tilt | FK-331-A | 1:8.3 | 0.128 | 1.119 | 0.143 | |
| 1880.00 | 661 | GSM 1900 | GSM | 29.5 | 29.01 | 0.02 | Left | Cheek | FK-331-A | 1:8.3 | 0.424 | 1.119 | 0.474 | A2 |
| 1880.00 | 661 | GSM 1900 | GSM | 29.5 | 29.01 | 0.09 | Left | Tilt | FK-331-A | 1:8.3 | 0.120 | 1.119 | 0.134 | |
| ANSI / IEEE C95.1 1992 - SAFETY LIMIT Spatial Peak Uncontrolled Exposure/General Population | | | | | | | | Head 1.6 W/kg (mW/g) averaged over 1 gram | | | | | | |

**Table 10-3
UMTS 1900 Head SAR**

| MEASUREMENT RESULTS | | | | | | | | | | | | | | |
|---|------|-----------|---------|-----------------------------|-----------------------|------------------|-------|---|----------------------|------------|----------|----------------|-----------------|--------|
| FREQUENCY | | Mode/Band | Service | Maximum Allowed Power [dBm] | Conducted Power [dBm] | Power Drift [dB] | Side | Test Position | Device Serial Number | Duty Cycle | SAR (1g) | Scaling Factor | Scaled SAR (1g) | Plot # |
| MHz | Ch. | | | | | | | | | | (W/kg) | | (W/kg) | |
| 1880.00 | 9400 | UMTS 1900 | RMC | 23.0 | 22.94 | 0.07 | Right | Cheek | FK-331-A | 1:1 | 0.369 | 1.014 | 0.374 | |
| 1880.00 | 9400 | UMTS 1900 | RMC | 23.0 | 22.94 | 0.07 | Right | Tilt | FK-331-A | 1:1 | 0.185 | 1.014 | 0.188 | |
| 1880.00 | 9400 | UMTS 1900 | RMC | 23.0 | 22.94 | -0.07 | Left | Cheek | FK-331-A | 1:1 | 0.632 | 1.014 | 0.641 | A3 |
| 1880.00 | 9400 | UMTS 1900 | RMC | 23.0 | 22.94 | 0.02 | Left | Tilt | FK-331-A | 1:1 | 0.173 | 1.014 | 0.175 | |
| ANSI / IEEE C95.1 1992 - SAFETY LIMIT Spatial Peak Uncontrolled Exposure/General Population | | | | | | | | Head 1.6 W/kg (mW/g) averaged over 1 gram | | | | | | |

**Table 10-4
DTS Head SAR**

| MEASUREMENT RESULTS | | | | | | | | | | | | | | | |
|---|-----|--------------|---------|-----------------------------|-----------------------|------------------|-------|---|----------------------|------------------|------------|----------|----------------|-----------------|--------|
| FREQUENCY | | Mode | Service | Maximum Allowed Power [dBm] | Conducted Power [dBm] | Power Drift [dB] | Side | Test Position | Device Serial Number | Data Rate (Mbps) | Duty Cycle | SAR (1g) | Scaling Factor | Scaled SAR (1g) | Plot # |
| MHz | Ch. | | | | | | | | | | | (W/kg) | | (W/kg) | |
| 2462 | 11 | IEEE 802.11b | DSSS | 15.5 | 15.20 | 0.06 | Right | Cheek | FK-331-A | 1 | 1:1 | 0.580 | 1.072 | 0.622 | A4 |
| 2462 | 11 | IEEE 802.11b | DSSS | 15.5 | 15.20 | 0.18 | Right | Tilt | FK-331-A | 1 | 1:1 | 0.075 | 1.072 | 0.080 | |
| 2462 | 11 | IEEE 802.11b | DSSS | 15.5 | 15.20 | -0.14 | Left | Cheek | FK-331-A | 1 | 1:1 | 0.305 | 1.072 | 0.327 | |
| 2462 | 11 | IEEE 802.11b | DSSS | 15.5 | 15.20 | 0.16 | Left | Tilt | FK-331-A | 1 | 1:1 | 0.099 | 1.072 | 0.106 | |
| ANSI / IEEE C95.1 1992 - SAFETY LIMIT Spatial Peak Uncontrolled Exposure/General Population | | | | | | | | Head 1.6 W/kg (mW/g) averaged over 1 gram | | | | | | | |

| | | | | |
|-----------------------------------|---|-------------------------------|---|---------------------------------|
| FCC ID: A3LGT56790E |  | SAR EVALUATION REPORT |  | Reviewed by: Quality Manager |
| Document S/N: OY1310312083.A3L | Test Dates: 11/04/13 - 11/06/13 | DUT Type: Portable Handset | | Page 23 of 35 |

10.2 Standalone Body-Worn SAR Data

**Table 10-5
GSM/UMTS Body-Worn SAR Data**

| MEASUREMENT RESULTS | | | | | | | | | | | | | | | |
|---|------|-----------|---------|-----------------------------|-----------------------|------------------|---|----------------------|-----------------|------------|------|----------|----------------|-----------------|--------|
| FREQUENCY | | Mode | Service | Maximum Allowed Power [dBm] | Conducted Power [dBm] | Power Drift [dB] | Spacing | Device Serial Number | # of Time Slots | Duty Cycle | Side | SAR (1g) | Scaling Factor | Scaled SAR (1g) | Plot # |
| MHz | Ch. | | | | | | | | | | | (W/kg) | | (W/kg) | |
| 836.60 | 190 | GSM 850 | GSM | 33.0 | 32.49 | 0.00 | 10 mm | FK-331-A | 1 | 1:8.3 | back | 0.575 | 1.125 | 0.647 | A5 |
| 1880.00 | 661 | GSM 1900 | GSM | 29.5 | 29.01 | -0.03 | 10 mm | FK-331-A | 1 | 1:8.3 | back | 0.342 | 1.119 | 0.383 | A7 |
| 1880.00 | 9400 | UMTS 1900 | RMC | 23.0 | 22.94 | -0.01 | 10 mm | FK-331-B | N/A | 1:1 | back | 0.506 | 1.014 | 0.513 | A9 |
| ANSI / IEEE C95.1 1992 - SAFETY LIMIT Spatial Peak Uncontrolled Exposure/General Population | | | | | | | Body 1.6 W/kg (mW/g) averaged over 1 gram | | | | | | | | |



**Table 10-6
DTS Body-Worn SAR**

| MEASUREMENT RESULTS | | | | | | | | | | | | | | | |
|---|-----|--------------|---------|-----------------------------|-----------------------|------------------|---|----------------------|------------------|------|------------|----------|----------------|-----------------|--------|
| FREQUENCY | | Mode | Service | Maximum Allowed Power [dBm] | Conducted Power [dBm] | Power Drift [dB] | Spacing | Device Serial Number | Data Rate (Mbps) | Side | Duty Cycle | SAR (1g) | Scaling Factor | Scaled SAR (1g) | Plot # |
| MHz | Ch. | | | | | | | | | | | (W/kg) | | (W/kg) | |
| 2462 | 11 | IEEE 802.11b | DSSS | 15.5 | 15.20 | 0.03 | 10 mm | FK-331-B | 1 | back | 1:1 | 0.237 | 1.072 | 0.254 | A10 |
| ANSI / IEEE C95.1 1992 - SAFETY LIMIT Spatial Peak Uncontrolled Exposure/General Population | | | | | | | Body 1.6 W/kg (mW/g) averaged over 1 gram | | | | | | | | |

10.3 Standalone Wireless Router SAR Data

**Table 10-7
GPRS/UMTS Hotspot SAR Data**

| MEASUREMENT RESULTS | | | | | | | | | | | | | | | |
|---|------|-----------|---------|-----------------------------|-----------------------|------------------|---|----------------------|-----------------|------------|--------|----------|----------------|-----------------|--------|
| FREQUENCY | | Mode | Service | Maximum Allowed Power [dBm] | Conducted Power [dBm] | Power Drift [dB] | Spacing | Device Serial Number | # of GPRS Slots | Duty Cycle | Side | SAR (1g) | Scaling Factor | Scaled SAR (1g) | Plot # |
| MHz | Ch. | | | | | | | | | | | (W/kg) | | (W/kg) | |
| 836.60 | 190 | GSM 850 | GPRS | 27.5 | 26.92 | 0.00 | 10 mm | FK-331-A | 4 | 1:2.076 | back | 0.571 | 1.143 | 0.653 | A6 |
| 836.60 | 190 | GSM 850 | GPRS | 27.5 | 26.92 | 0.04 | 10 mm | FK-331-A | 4 | 1:2.076 | front | 0.360 | 1.143 | 0.411 | |
| 836.60 | 190 | GSM 850 | GPRS | 27.5 | 26.92 | 0.01 | 10 mm | FK-331-A | 4 | 1:2.076 | bottom | 0.121 | 1.143 | 0.138 | |
| 836.60 | 190 | GSM 850 | GPRS | 27.5 | 26.92 | -0.04 | 10 mm | FK-331-A | 4 | 1:2.076 | left | 0.374 | 1.143 | 0.427 | |
| 1880.00 | 661 | GSM 1900 | GPRS | 24.5 | 24.20 | -0.02 | 10 mm | FK-331-A | 4 | 1:2.076 | back | 0.444 | 1.072 | 0.476 | A8 |
| 1880.00 | 661 | GSM 1900 | GPRS | 24.5 | 24.20 | -0.05 | 10 mm | FK-331-A | 4 | 1:2.076 | front | 0.347 | 1.072 | 0.372 | |
| 1880.00 | 661 | GSM 1900 | GPRS | 24.5 | 24.20 | 0.08 | 10 mm | FK-331-A | 4 | 1:2.076 | bottom | 0.296 | 1.072 | 0.317 | |
| 1880.00 | 661 | GSM 1900 | GPRS | 24.5 | 24.20 | 0.03 | 10 mm | FK-331-A | 4 | 1:2.076 | left | 0.110 | 1.072 | 0.118 | |
| 1880.00 | 9400 | UMTS 1900 | RMC | 23.0 | 22.94 | -0.01 | 10 mm | FK-331-B | N/A | 1:1 | back | 0.506 | 1.014 | 0.513 | A9 |
| 1880.00 | 9400 | UMTS 1900 | RMC | 23.0 | 22.94 | -0.05 | 10 mm | FK-331-B | N/A | 1:1 | front | 0.342 | 1.014 | 0.347 | |
| 1880.00 | 9400 | UMTS 1900 | RMC | 23.0 | 22.94 | -0.02 | 10 mm | FK-331-B | N/A | 1:1 | bottom | 0.401 | 1.014 | 0.407 | |
| 1880.00 | 9400 | UMTS 1900 | RMC | 23.0 | 22.94 | -0.01 | 10 mm | FK-331-B | N/A | 1:1 | left | 0.108 | 1.014 | 0.110 | |
| ANSI / IEEE C95.1 1992 - SAFETY LIMIT Spatial Peak Uncontrolled Exposure/General Population | | | | | | | Body 1.6 W/kg (mW/g) averaged over 1 gram | | | | | | | | |

| | | | | |
|-----------------------------------|---|-------------------------------|---|---------------------------------|
| FCC ID: A3LGT56790E |  | SAR EVALUATION REPORT |  | Reviewed by: Quality Manager |
| Document S/N: OY1310312083.A3L | Test Dates: 11/04/13 - 11/06/13 | DUT Type: Portable Handset | Page 24 of 35 | |

**Table 10-8
WLAN Hotspot SAR**

| MEASUREMENT RESULTS | | | | | | | | | | | | | | | |
|---|-----|--------------|---------|-----------------------------|-----------------------|------------------|---|----------------------|------------------|--------|------------|----------|----------------|-----------------|--------|
| FREQUENCY | | Mode | Service | Maximum Allowed Power [dBm] | Conducted Power [dBm] | Power Drift [dB] | Spacing | Device Serial Number | Data Rate (Mbps) | Side | Duty Cycle | SAR (1g) | Scaling Factor | Scaled SAR (1g) | Plot # |
| MHz | Ch. | | | | | | | | | | | (W/kg) | | (W/kg) | |
| 2462 | 11 | IEEE 802.11b | DSSS | 15.5 | 15.20 | 0.03 | 10 mm | FK-331-B | 1 | back | 1:1 | 0.237 | 1.072 | 0.254 | |
| 2462 | 11 | IEEE 802.11b | DSSS | 15.5 | 15.20 | -0.01 | 10 mm | FK-331-B | 1 | front | 1:1 | 0.271 | 1.072 | 0.291 | A11 |
| 2462 | 11 | IEEE 802.11b | DSSS | 15.5 | 15.20 | 0.05 | 10 mm | FK-331-B | 1 | bottom | 1:1 | 0.230 | 1.072 | 0.247 | |
| 2462 | 11 | IEEE 802.11b | DSSS | 15.5 | 15.20 | 0.06 | 10 mm | FK-331-B | 1 | right | 1:1 | 0.202 | 1.072 | 0.217 | |
| ANSI / IEEE C95.1 1992 - SAFETY LIMIT Spatial Peak Uncontrolled Exposure/General Population | | | | | | | Body 1.6 W/kg (mW/g) averaged over 1 gram | | | | | | | | |



10.4 SAR Test Notes

General Notes:

1. The test data reported are the worst-case SAR values according to test procedures specified in IEEE 1528-2003, FCC/OET Bulletin 65, Supplement C [June 2001] and FCC KDB Publication 447498 D01v05.
2. Batteries are fully charged at the beginning of the SAR measurements. A standard battery was used for all SAR measurements.
3. Liquid tissue depth was at least 15.0 cm for all frequencies.
4. The manufacturer has confirmed that the device(s) tested have the same physical, mechanical and thermal characteristics and are within operational tolerances expected for production units.
5. SAR results were scaled to the maximum allowed power to demonstrate compliance per FCC KDB Publication 447498 D01v05.
6. Device was tested using a fixed spacing for body-worn accessory testing. A separation distance of 10 mm was considered because the manufacturer has determined that there will be body-worn accessories available in the marketplace for users to support this separation distance.
7. Per FCC KDB Publication 648474 D04v01, SAR was evaluated without a headset connected to the device. Since the standalone reported SAR was ≤ 1.2 W/kg, no additional SAR evaluations using a headset cable were required.
8. Per FCC KDB 865664 D01 v01, variability SAR tests were not performed since the measured SAR results were less than 0.8 W/kg. Please see Section 12 for variability analysis.
9. During SAR Testing for the Wireless Router conditions per FCC KDB Publication 941225 D06v01, the actual Portable Hotspot operation (with actual simultaneous transmission of a transmitter with WIFI) was not activated (See Section 5.7 for more details).

GSM Test Notes:

1. Body-Worn accessory testing is typically associated with voice operations. Therefore, GSM voice was evaluated for body-worn SAR.
2. Justification for reduced test configurations per KDB Publication 941225 D03v01 and October 2013 TCB Workshop Notes: The source-based frame-averaged output power was evaluated for all GPRS slot configurations. The configuration with the highest target frame averaged output power was evaluated for hotspot SAR. When the maximum frame-averaged powers are equivalent across two or more slots (within 0.25 dB), the configuration with the most number of time slots was tested.
3. Per FCC KDB Publication 447498 D01v05, since the reported (scaled) SAR measured at the middle channel for each test configuration is ≤ 0.8 W/kg, testing at the other channels is not required for such test configuration(s). The maximum output power variation across the required test channels is $< \frac{1}{2}$ dB; therefore, the middle channel was default channel used.



| | | | | |
|-----------------------------------|---|-------------------------------|---|---------------------------------|
| FCC ID: A3LGT56790E |  | SAR EVALUATION REPORT |  | Reviewed by: Quality Manager |
| Document S/N: OY1310312083.A3L | Test Dates: 11/04/13 - 11/06/13 | DUT Type: Portable Handset | Page 25 of 35 | |

UMTS Notes:

1. UMTS mode in Body SAR was tested under RMC 12.2 kbps with HSPA Inactive per KDB Publication 941225 D01v02. HSPA SAR was not required since the average output power of the HSPA subtests was not more than 0.25 dB higher than the RMC level and SAR was less than 1.2 W/kg.
2. Per FCC KDB Publication 447498 D01v05, since the reported (scaled) SAR measured at the middle channel for each test configuration is ≤ 0.8 W/kg, testing at the other channels is not required for such test configurations. Since the maximum output power variation across the required test channels is $< \frac{1}{2}$ dB the middle channel was the default channel used.

WLAN Notes:

1. Justification for reduced test configurations for WIFI channels per KDB Publication 248227 D01v01r02 and October 2012 FCC/TCB Meeting Notes for 2.4 GHz WIFI: Highest average RF output power channel for the lowest data rate was selected for SAR evaluation in 802.11b. Other IEEE 802.11 modes (including 802.11g/n) were not investigated since the average output powers over all channels and data rates were not more than 0.25 dB higher than the tested channel in the lowest data rate of IEEE 802.11b mode.
2. WIFI transmission was verified using an uncalibrated spectrum analyzer.
3. Since the maximum extrapolated peak SAR of the zoom scan for the maximum output channel is < 1.6 W/kg and the reported 1g averaged SAR is < 0.8 W/kg, SAR testing on other default channels was not required.

| | | | | |
|-----------------------------------|--|-------------------------------|---|---------------------------------|
| FCC ID: A3LGTS6790E |  PCTEST ENGINEERING LABORATORY, INC. | SAR EVALUATION REPORT |  SAMSUNG | Reviewed by: Quality Manager |
| Document S/N: OY1310312083.A3L | Test Dates: 11/04/13 - 11/06/13 | DUT Type: Portable Handset | | Page 26 of 35 |

11 FCC MULTI-TX AND ANTENNA SAR CONSIDERATIONS

11.1 Introduction

The following procedures adopted from FCC KDB Publication 447498 D01v05 are applicable to handsets with built-in unlicensed transmitters such as 802.11b/g/n and Bluetooth devices which may simultaneously transmit with the licensed transmitter.

11.2 Simultaneous Transmission Procedures



This device contains transmitters that may operate simultaneously. Therefore simultaneous transmission analysis is required. Per FCC KDB 447498 D01v05 IV.C.1.iii, simultaneous transmission SAR test exclusion may be applied when the sum of the 1-g SAR for all the simultaneous transmitting antennas in a specific a physical test configuration is ≤ 1.6 W/kg. When standalone SAR is not required to be measured, per FCC KDB 447498 D01v05 4.3.2 2), the following equation must be used to estimate the standalone 1g SAR for simultaneous transmission assessment involving that transmitter.

$$\text{Estimated SAR} = \frac{\sqrt{f(\text{GHz})}}{7.5} * \frac{(\text{Max Power of channel, mW})}{\text{Min. Separation Distance, mm}}$$

**Table 11-1
Estimated SAR**

| Mode | Frequency | Maximum Allowed Power | Separation Distance (Body) | Estimated SAR (Body) |
|-----------|-----------|-----------------------|----------------------------|----------------------|
| | [MHz] | [dBm] | [mm] | [W/kg] |
| Bluetooth | 2441 | 10.00 | 10 | 0.208 |

Note: Held-to ear configurations are not applicable to Bluetooth operations and therefore were not considered for simultaneous transmission. Per KDB Publication 447498 D01v05, the maximum power of the channel was rounded to the nearest mW before calculation.

| | | | | |
|-----------------------------------|---|-------------------------------|---|---------------------------------|
| FCC ID: A3LGTS6790E |  PCTEST ENGINEERING LABORATORY, INC. | SAR EVALUATION REPORT |  | Reviewed by: Quality Manager |
| Document S/N: 0Y1310312083.A3L | Test Dates: 11/04/13 - 11/06/13 | DUT Type: Portable Handset | | Page 27 of 35 |

11.3 Head SAR Simultaneous Transmission Analysis

Table 11-2
Simultaneous Transmission Scenario with 2.4 GHz WLAN (Held to Ear)

| Simult Tx | Configuration | GSM 850 SAR (W/kg) | 2.4 GHz WLAN SAR (W/kg) | Σ SAR (W/kg) | Simult Tx | Configuration | GSM 1900 SAR (W/kg) | 2.4 GHz WLAN SAR (W/kg) | Σ SAR (W/kg) |
|-----------|---------------|--------------------|-------------------------|--------------|-----------|---------------|---------------------|-------------------------|--------------|
| Head SAR | Right Cheek | 0.340 | 0.622 | 0.962 | Head SAR | Right Cheek | 0.300 | 0.622 | 0.922 |
| | Right Tilt | 0.225 | 0.080 | 0.305 | | Right Tilt | 0.143 | 0.080 | 0.223 |
| | Left Cheek | 0.397 | 0.327 | 0.724 | | Left Cheek | 0.474 | 0.327 | 0.801 |
| | Left Tilt | 0.212 | 0.106 | 0.318 | | Left Tilt | 0.134 | 0.106 | 0.240 |

| Simult Tx | Configuration | UMTS 1900 SAR (W/kg) | 2.4 GHz WLAN SAR (W/kg) | Σ SAR (W/kg) |
|-----------|---------------|----------------------|-------------------------|--------------|
| Head SAR | Right Cheek | 0.374 | 0.622 | 0.996 |
| | Right Tilt | 0.188 | 0.080 | 0.268 |
| | Left Cheek | 0.641 | 0.327 | 0.968 |
| | Left Tilt | 0.175 | 0.106 | 0.281 |

11.4 Body-Worn Simultaneous Transmission Analysis



Table 11-3
Simultaneous Transmission Scenario with 2.4 GHz WLAN (Body-Worn at 10 mm)

| Configuration | Mode | 2G/3G SAR (W/kg) | 2.4 GHz WLAN SAR (W/kg) | Σ SAR (W/kg) |
|---------------|-----------|------------------|-------------------------|--------------|
| Back Side | GSM 850 | 0.647 | 0.254 | 0.901 |
| Back Side | GSM 1900 | 0.383 | 0.254 | 0.637 |
| Back Side | UMTS 1900 | 0.513 | 0.254 | 0.767 |

Table 11-4
Simultaneous Transmission Scenario with Bluetooth (Body-Worn at 10 mm)

| Configuration | Mode | 2G/3G SAR (W/kg) | Bluetooth SAR (W/kg) | Σ SAR (W/kg) |
|---------------|-----------|------------------|----------------------|--------------|
| Back Side | GSM 850 | 0.647 | 0.208 | 0.855 |
| Back Side | GSM 1900 | 0.383 | 0.208 | 0.591 |
| Back Side | UMTS 1900 | 0.513 | 0.208 | 0.721 |

Note: Bluetooth SAR was not required to be measured per FCC KDB 447498. Estimated SAR results were used in the above table to determine simultaneous transmission SAR test exclusion.

| | | | | |
|-----------------------------------|---|-------------------------------|---|---------------------------------|
| FCC ID: A3LGTS6790E |  | SAR EVALUATION REPORT |  | Reviewed by: Quality Manager |
| Document S/N: OY1310312083.A3L | Test Dates: 11/04/13 - 11/06/13 | DUT Type: Portable Handset | Page 28 of 35 | |

11.5 Hotspot SAR Simultaneous Transmission Analysis

Per FCC KDB Publication 941225 D06v01, the devices edges with antennas more than 2.5 cm from edge are not required to be evaluated for SAR (“-”).



**Table 11-5
Simultaneous Transmission Scenario (2.4 GHz Hotspot at 1.0 cm)**

| Simult Tx | Configuration | GPRS 850 SAR (W/kg) | 2.4 GHz WLAN SAR (W/kg) | Σ SAR (W/kg) | Simult Tx | Configuration | GPRS 1900 SAR (W/kg) | 2.4 GHz WLAN SAR (W/kg) | Σ SAR (W/kg) |
|-----------|---------------|---------------------|-------------------------|--------------|-----------|---------------|----------------------|-------------------------|--------------|
| Body SAR | Back | 0.653 | 0.254 | 0.907 | Body SAR | Back | 0.476 | 0.254 | 0.730 |
| | Front | 0.411 | 0.291 | 0.702 | | Front | 0.372 | 0.291 | 0.663 |
| | Top | - | - | 0.000 | | Top | - | - | 0.000 |
| | Bottom | 0.138 | 0.247 | 0.385 | | Bottom | 0.317 | 0.247 | 0.564 |
| | Right | - | 0.217 | 0.217 | | Right | - | 0.217 | 0.217 |
| | Left | 0.427 | - | 0.427 | | Left | 0.118 | - | 0.118 |

| Simult Tx | Configuration | UMTS 1900 SAR (W/kg) | 2.4 GHz WLAN SAR (W/kg) | Σ SAR (W/kg) |
|-----------|---------------|----------------------|-------------------------|--------------|
| Body SAR | Back | 0.513 | 0.254 | 0.767 |
| | Front | 0.347 | 0.291 | 0.638 |
| | Top | - | - | 0.000 |
| | Bottom | 0.407 | 0.247 | 0.654 |
| | Right | - | 0.217 | 0.217 |
| | Left | 0.110 | - | 0.110 |

11.6 Simultaneous Transmission Conclusion

The above numerical summed SAR results for all the worst-case simultaneous transmission conditions were below the SAR limit. Therefore, the above analysis is sufficient to determine that simultaneous transmission cases will not exceed the SAR limit and therefore no measured volumetric simultaneous SAR summation is required per FCC KDB Publication 447498 D01v05.

| | | | | |
|--|---|--------------------------------------|---|--|
| FCC ID: A3LGTS6790E |  | SAR EVALUATION REPORT |  | Reviewed by: Quality Manager |
| Document S/N: OY1310312083.A3L | Test Dates: 11/04/13 - 11/06/13 | DUT Type: Portable Handset | Page 29 of 35 | |



12 SAR MEASUREMENT VARIABILITY

12.1 Measurement Variability

Per FCC KDB Publication 865664 D01v01, SAR measurement variability is assessed when 1 gram SAR is > 0.8 W/kg. Since all the measured 1 gram SAR values are < 0.8 W/kg for this device, SAR measurement variability was not assessed.

12.2 Measurement Uncertainty



The measured SAR was < 1.5 W/kg for all frequency bands. Therefore, per KDB Publication 865664 D01v01, the extended measurement uncertainty analysis per IEEE 1528-2003 was not required.

| | | | | |
|-----------------------------------|---|-------------------------------|---|---------------------------------|
| FCC ID: A3LGTS6790E |  PCTEST ENGINEERING LABORATORY, INC. | SAR EVALUATION REPORT |  | Reviewed by: Quality Manager |
| Document S/N: 0Y1310312083.A3L | Test Dates: 11/04/13 - 11/06/13 | DUT Type: Portable Handset | | Page 30 of 35 |

13 EQUIPMENT LIST

| Manufacturer | Model | Description | Cal Date | Cal Interval | Cal Due | Serial Number |
|--------------------|-----------|---|------------|--------------|------------|---------------|
| Agilent | E8257D | (250kHz-20GHz) Signal Generator | 4/16/2013 | Annual | 4/16/2014 | MY45470194 |
| Agilent | 8753E | (30kHz-6GHz) Network Analyzer | 7/23/2013 | Annual | 7/23/2014 | US37390350 |
| Agilent | 8648D | (9kHz-4GHz) Signal Generator | 4/17/2013 | Annual | 4/17/2014 | 3629U00687 |
| Agilent | 85070C | Dielectric Probe Kit | 2/14/2013 | Annual | 2/14/2014 | MY44300633 |
| Agilent | N9020A | MXA Signal Analyzer | 11/9/2012 | Annual | 11/9/2013 | US46470561 |
| Agilent | 85047A | S-Parameter Test Set | N/A | N/A | N/A | 2904A00579 |
| Amplifier Research | 551G4 | 5W, 800MHz-4.2GHz | CBT | N/A | CBT | 21910 |
| Anritsu | ML2496A | Power Meter | 11/28/2012 | Annual | 11/28/2013 | 1138001 |
| Anritsu | ML2438A | Power Meter | 12/4/2012 | Annual | 12/4/2013 | 1070030 |
| Anritsu | MA2481A | Power Sensor | 2/14/2013 | Annual | 2/14/2014 | 5318 |
| Anritsu | MA2481A | Power Sensor | 2/14/2013 | Annual | 2/14/2014 | 2400 |
| Anritsu | MA2411B | Pulse Power Sensor | 12/4/2012 | Annual | 12/4/2013 | 1207364 |
| Anritsu | MT8820C | Radio Communication Analyzer | 6/28/2013 | Annual | 6/28/2014 | 6201240328 |
| Anritsu | MA2481D | Universal Sensor | 12/17/2012 | Annual | 12/17/2013 | 1204343 |
| Anritsu | MA24106A | USB Power Sensor | 12/7/2012 | Annual | 12/7/2013 | 1244515 |
| Anritsu | MA24106A | USB Power Sensor | 12/7/2012 | Annual | 12/7/2013 | 1244512 |
| COMTech | AR85729-5 | Solid State Amplifier | CBT | N/A | CBT | M155A00-009 |
| Control Company | 36934-158 | Wall-Mounted Thermometer | 1/4/2012 | Biennial | 1/4/2014 | 122014488 |
| Fisher Scientific | 15-07BJ | Long Stem Thermometer | 1/7/2013 | Biennial | 1/7/2015 | 130018243 |
| MCL | BW-N6W5+ | 6dB Attenuator | CBT | N/A | CBT | 1139 |
| MiniCircuits | SLP-2400+ | Low Pass Filter | CBT | N/A | CBT | R8979500903 |
| Mini-Circuits | BW-N20W5+ | DC to 18 GHz Precision Fixed 20 dB Attenuator | CBT | N/A | CBT | N/A |
| Mini-Circuits | NLP-1200+ | Low Pass Filter DC to 1000 MHz | CBT | N/A | CBT | N/A |
| Mini-Circuits | BW-N20W5 | Power Attenuator | CBT | N/A | CBT | 1226 |
| Narda | 4014C-6 | 4 - 8 GHz SMA 6 dB Directional Coupler | CBT | N/A | CBT | N/A |
| Narda | BW-S3W2 | Attenuator (3dB) | CBT | N/A | CBT | 120 |
| Pasternack | PE2208-6 | Bidirectional Coupler | CBT | N/A | CBT | N/A |
| Pasternack | PE2209-10 | Bidirectional Coupler | CBT | N/A | CBT | N/A |
| Rohde & Schwarz | CMU200 | Base Station Simulator | 5/3/2013 | Annual | 5/3/2014 | 836371/0079 |
| Rohde & Schwarz | CMU200 | Base Station Simulator | 9/23/2013 | Annual | 9/23/2014 | 109892 |
| Rohde & Schwarz | NRVD | Dual Channel Power Meter | 10/12/2012 | Biennial | 10/12/2014 | 101695 |
| Rohde & Schwarz | NRV-Z32 | Peak Power Sensor | 10/12/2012 | Biennial | 10/12/2014 | 836019/013 |
| Rohde & Schwarz | SMIQ03B | Signal Generator | 4/17/2013 | Annual | 4/17/2014 | DE27259 |
| Seekonk | NC-100 | Torque Wrench (8" lb) | 11/29/2011 | Triennial | 11/29/2014 | 21053 |
| SPEAG | D1900V2 | 1900 MHz SAR Dipole | 2/6/2013 | Annual | 2/6/2014 | 5d148 |
| SPEAG | D2450V2 | 2450 MHz SAR Dipole | 1/8/2013 | Annual | 1/8/2014 | 797 |
| SPEAG | D2450V2 | 2450 MHz SAR Dipole | 2/11/2013 | Annual | 2/11/2014 | 882 |
| SPEAG | D835V2 | 835 MHz SAR Dipole | 4/25/2013 | Annual | 4/25/2014 | 4d119 |
| SPEAG | DAE4 | Dasy Data Acquisition Electronics | 3/8/2013 | Annual | 3/8/2014 | 1334 |
| SPEAG | DAE4 | Dasy Data Acquisition Electronics | 4/22/2013 | Annual | 4/22/2014 | 1364 |
| SPEAG | DAE4 | Dasy Data Acquisition Electronics | 4/22/2013 | Annual | 4/22/2014 | 1368 |
| SPEAG | DAE4 | Dasy Data Acquisition Electronics | 5/13/2013 | Annual | 5/13/2014 | 859 |
| SPEAG | DAE4 | Dasy Data Acquisition Electronics | 8/21/2013 | Annual | 8/21/2014 | 1322 |
| SPEAG | DAKS-3.5 | Portable Dielectric Assessment Kit | 8/18/2013 | Annual | 8/18/2014 | 1008 |
| SPEAG | ES3DV3 | SAR Probe | 3/15/2013 | Annual | 3/15/2014 | 3209 |
| SPEAG | ES3DV3 | SAR Probe | 4/29/2013 | Annual | 4/29/2014 | 3318 |
| SPEAG | ES3DV3 | SAR Probe | 4/29/2013 | Annual | 4/29/2014 | 3319 |
| SPEAG | ES3DV3 | SAR Probe | 5/16/2013 | Annual | 5/16/2014 | 3263 |
| SPEAG | ES3DV2 | SAR Probe | 8/22/2013 | Annual | 8/22/2014 | 3022 |
| Tektronix | RSA6114A | Real Time Spectrum Analyzer | 4/17/2013 | Annual | 4/17/2014 | 8010177 |
| VWR | 23226-658 | Long Stem Thermometer | 3/30/2012 | Biennial | 3/30/2014 | 122179874 |
| VWR | 23226-658 | Long Stem Thermometer | 5/16/2012 | Biennial | 5/16/2014 | 122295544 |



Note: CBT (Calibrated Before Testing). Prior to testing, the measurement paths containing a cable, amplifier, attenuator, coupler or filter were connected to a calibrated source (i.e. a signal generator) to determine the losses of the measurement path. The power meter offset was then adjusted to compensate for the measurement system losses. This level offset is stored within the power meter before measurements are made. This calibration verification procedure applies to the system verification and output power measurements. The calibrated reading is then taken directly from the power meter after compensation of the losses for all final power measurements.

| | | | | |
|--|---|--------------------------------------|---|--|
| FCC ID: A3LGT56790E |  PCTEST ENGINEERING LABORATORY, INC. | SAR EVALUATION REPORT |  | Reviewed by: Quality Manager |
| Document S/N: OY1310312083.A3L | Test Dates: 11/04/13 - 11/06/13 | DUT Type: Portable Handset | Page 31 of 35 | |

14 MEASUREMENT UNCERTAINTIES

| a | b | c | d | e= f(d,k) | f | g | h = c x f/e | i = c x g/e | k |
|---|----------------------|---------------|----------------|--------------|-----------------------|--------------------------|--------------------------------|----------------------------------|----------------|
| Uncertainty Component | IEEE 1528 Sec. | Tol. (± %) | Prob. Dist. | Div. | c _i 1gm | c _i 10 gms | 1gm u _i (± %) | 10gms u _i (± %) | v _i |
| Measurement System | | | | | | | | | |
| Probe Calibration | E.2.1 | 6.0 | N | 1 | 1.0 | 1.0 | 6.0 | 6.0 | ∞ |
| Axial Isotropy | E.2.2 | 0.25 | N | 1 | 0.7 | 0.7 | 0.2 | 0.2 | ∞ |
| Hemishperical Isotropy | E.2.2 | 1.3 | N | 1 | 1.0 | 1.0 | 1.3 | 1.3 | ∞ |
| Boundary Effect | E.2.3 | 0.4 | N | 1 | 1.0 | 1.0 | 0.4 | 0.4 | ∞ |
| Linearity | E.2.4 | 0.3 | N | 1 | 1.0 | 1.0 | 0.3 | 0.3 | ∞ |
| System Detection Limits | E.2.5 | 5.1 | N | 1 | 1.0 | 1.0 | 5.1 | 5.1 | ∞ |
| Readout Electronics | E.2.6 | 1.0 | N | 1 | 1.0 | 1.0 | 1.0 | 1.0 | ∞ |
| Response Time | E.2.7 | 0.8 | R | 1.73 | 1.0 | 1.0 | 0.5 | 0.5 | ∞ |
| Integration Time | E.2.8 | 2.6 | R | 1.73 | 1.0 | 1.0 | 1.5 | 1.5 | ∞ |
| RF Ambient Conditions | E.6.1 | 3.0 | R | 1.73 | 1.0 | 1.0 | 1.7 | 1.7 | ∞ |
| Probe Positioner Mechanical Tolerance | E.6.2 | 0.4 | R | 1.73 | 1.0 | 1.0 | 0.2 | 0.2 | ∞ |
| Probe Positioning w/ respect to Phantom | E.6.3 | 2.9 | R | 1.73 | 1.0 | 1.0 | 1.7 | 1.7 | ∞ |
| Extrapolation, Interpolation & Integration algorithms for Max. SAR Evaluation | E.5 | 1.0 | R | 1.73 | 1.0 | 1.0 | 0.6 | 0.6 | ∞ |
| Test Sample Related | | | | | | | | | |
| Test Sample Positioning | E.4.2 | 6.0 | N | 1 | 1.0 | 1.0 | 6.0 | 6.0 | 287 |
| Device Holder Uncertainty | E.4.1 | 3.32 | R | 1.73 | 1.0 | 1.0 | 1.9 | 1.9 | ∞ |
| Output Power Variation - SAR drift measurement | 6.6.2 | 5.0 | R | 1.73 | 1.0 | 1.0 | 2.9 | 2.9 | ∞ |
| Phantom & Tissue Parameters | | | | | | | | | |
| Phantom Uncertainty (Shape & Thickness tolerances) | E.3.1 | 4.0 | R | 1.73 | 1.0 | 1.0 | 2.3 | 2.3 | ∞ |
| Liquid Conductivity - deviation from target values | E.3.2 | 5.0 | R | 1.73 | 0.64 | 0.43 | 1.8 | 1.2 | ∞ |
| Liquid Conductivity - measurement uncertainty | E.3.3 | 3.8 | N | 1 | 0.64 | 0.43 | 2.4 | 1.6 | 6 |
| Liquid Permittivity - deviation from target values | E.3.2 | 5.0 | R | 1.73 | 0.60 | 0.49 | 1.7 | 1.4 | ∞ |
| Liquid Permittivity - measurement uncertainty | E.3.3 | 4.5 | N | 1 | 0.60 | 0.49 | 2.7 | 2.2 | 6 |
| Combined Standard Uncertainty (k=1) | | | | RSS | | | 12.1 | 11.7 | 299 |
| Expanded Uncertainty (95% CONFIDENCE LEVEL) | | | | k=2 | | | 24.2 | 23.5 | |

The above measurement uncertainties are according to IEEE Std. 1528-2003



| | | | | |
|-----------------------------------|---|-------------------------------|---|---------------------------------|
| FCC ID: A3LGT56790E |  | SAR EVALUATION REPORT |  | Reviewed by: Quality Manager |
| Document S/N: OY1310312083.A3L | Test Dates: 11/04/13 - 11/06/13 | DUT Type: Portable Handset | | Page 32 of 35 |

15 CONCLUSION

15.1 Measurement Conclusion



The SAR evaluation indicates that the EUT complies with the RF radiation exposure limits of the FCC and Industry Canada, with respect to all parameters subject to this test. These measurements were taken to simulate the RF effects of RF exposure under worst-case conditions. Precise laboratory measures were taken to assure repeatability of the tests. The results and statements relate only to the item(s) tested.

Please note that the absorption and distribution of electromagnetic energy in the body are very complex phenomena that depend on the mass, shape, and size of the body, the orientation of the body with respect to the field vectors, and the electrical properties of both the body and the environment. Other variables that may play a substantial role in possible biological effects are those that characterize the environment (e.g. ambient temperature, air velocity, relative humidity, and body insulation) and those that characterize the individual (e.g. age, gender, activity level, debilitation, or disease). Because various factors may interact with one another to vary the specific biological outcome of an exposure to electromagnetic fields, any protection guide should consider maximal amplification of biological effects as a result of field-body interactions, environmental conditions, and physiological variables. [3]



| | | | | |
|-----------------------------------|---|-------------------------------|---|---------------------------------|
| FCC ID: A3LGTS6790E |  | SAR EVALUATION REPORT |  | Reviewed by: Quality Manager |
| Document S/N: 0Y1310312083.A3L | Test Dates: 11/04/13 - 11/06/13 | DUT Type: Portable Handset | | Page 33 of 35 |

16 REFERENCES

- [1] Federal Communications Commission, ET Docket 93-62, Guidelines for Evaluating the Environmental Effects of Radiofrequency Radiation, Aug. 1996.
- [2] ANSI/IEEE C95.1-2005, American National Standard safety levels with respect to human exposure to radio frequency electromagnetic fields, 3kHz to 300GHz, New York: IEEE, 2006.
- [3] ANSI/IEEE C95.1-1992, American National Standard safety levels with respect to human exposure to radio frequency electromagnetic fields, 3kHz to 300GHz, New York: IEEE, Sept. 1992.
- [4] ANSI/IEEE C95.3-2002, IEEE Recommended Practice for the Measurement of Potentially Hazardous Electromagnetic Fields - RF and Microwave, New York: IEEE, December 2002.
- [5] Federal Communications Commission, OET Bulletin 65 (Edition 97-01), Supplement C (Edition 01-01), Evaluating Compliance with FCC Guidelines for Human Exposure to Radiofrequency Electromagnetic Fields, June 2001.
- [6] IEEE Standards Coordinating Committee 34 – IEEE Std. 1528-2003, Recommended Practice for Determining the Peak Spatial-Average Specific Absorption Rate (SAR) in the Human Body Due to Wireless Communications Devices.
- [7] NCRP, National Council on Radiation Protection and Measurements, Biological Effects and Exposure Criteria for RadioFrequency Electromagnetic Fields, NCRP Report No. 86, 1986. Reprinted Feb. 1995.
- [8] T. Schmid, O. Egger, N. Kuster, Automated E-field scanning system for dosimetric assessments, IEEE Transaction on Microwave Theory and Techniques, vol. 44, Jan. 1996, pp. 105-113.
- [9] K. Pokovic, T. Schmid, N. Kuster, Robust setup for precise calibration of E-field probes in tissue simulating liquids at mobile communications frequencies, ICECOM97, Oct. 1997, pp. -124.
- [10] K. Pokovic, T. Schmid, and N. Kuster, E-field Probe with improved isotropy in brain simulating liquids, Proceedings of the ELMAR, Zadar, Croatia, June 23-25, 1996, pp. 172-175.
- [11] Schmid & Partner Engineering AG, Application Note: Data Storage and Evaluation, June 1998, p2.
- [12] V. Hombach, K. Meier, M. Burkhardt, E. Kuhn, N. Kuster, The Dependence of EM Energy Absorption upon Human Modeling at 900 MHz, IEEE Transaction on Microwave Theory and Techniques, vol. 44 no. 10, Oct. 1996, pp. 1865-1873.
- [13] N. Kuster and Q. Balzano, Energy absorption mechanism by biological bodies in the near field of dipole antennas above 300MHz, IEEE Transaction on Vehicular Technology, vol. 41, no. 1, Feb. 1992, pp. 17-23.
- [14] G. Hartsgrrove, A. Kraszewski, A. Surowiec, Simulated Biological Materials for Electromagnetic Radiation Absorption Studies, University of Ottawa, Bioelectromagnetics, Canada: 1987, pp. 29-36.
- [15] Q. Balzano, O. Garay, T. Manning Jr., Electromagnetic Energy Exposure of Simulated Users of Portable Cellular Telephones, IEEE Transactions on Vehicular Technology, vol. 44, no.3, Aug. 1995.
- [16] W. Gander, Computermathematik, Birkhaeuser, Basel, 1992.
- [17] W.H. Press, S.A. Teukolsky, W.T. Vetterling, and B.P. Flannery, Numerical Recipes in C, The Art of Scientific Computing, Second edition, Cambridge University Press, 1992.

| | | | |
|-----------------------------------|---|-------------------------------|--|
| FCC ID: A3LGTS6790E |  | SAR EVALUATION REPORT |  Reviewed by: Quality Manager |
| Document S/N: OY1310312083.A3L | Test Dates: 11/04/13 - 11/06/13 | DUT Type: Portable Handset | Page 34 of 35 |

- [18] Federal Communications Commission, OET Bulletin 65, Evaluating Compliance with FCC Guidelines for Human Exposure to Radiofrequency Electromagnetic Fields. Supplement C, Dec. 1997.
- [19] N. Kuster, R. Kastle, T. Schmid, Dosimetric evaluation of mobile communications equipment with known precision, IEEE Transaction on Communications, vol. E80-B, no. 5, May 1997, pp. 645-652.
- [20] CENELEC CLC/SC111B, European Prestandard (prENV 50166-2), Human Exposure to Electromagnetic Fields High-frequency: 10kHz-300GHz, Jan. 1995.
- [21] Prof. Dr. Niels Kuster, ETH, Eidgenössische Technische Hochschule Zürich, Dosimetric Evaluation of the Cellular Phone.
- [22] IEC 62209-1, Human exposure to radio frequency fields from hand-held and body-mounted wireless communication devices - Human models, instrumentation, and procedures - Part 1: Procedure to determine the specific absorption rate (SAR) for hand-held devices used in close proximity to the ear (frequency range of 300 MHz to 3 GHz), Feb. 2005.
- [23] Industry Canada RSS-102 Radio Frequency Exposure Compliance of Radiocommunication Apparatus (All Frequency Bands) Issue 4, March 2010.
- [24] Health Canada Safety Code 6 Limits of Human Exposure to Radio Frequency Electromagnetic Fields in the Frequency Range from 3 kHz – 300 GHz, 2009
- [25] FCC Public Notice DA-02-1438. Office of Engineering and Technology Announces a Transition Period for the Phantom Requirements of Supplement C to OET Bulletin 65, June 19, 2002
- [26] FCC SAR Test Procedures for 2G-3G Devices, Mobile Hotspot and UMPC Devices KDB Publications 941225, D01-D07
- [27] SAR Measurement procedures for IEEE 802.11a/b/g KDB Publication 248227 D01v01r02
- [28] FCC SAR Considerations for Handsets with Multiple Transmitters and Antennas, KDB Publications 648474 D02-D04
- [29] FCC SAR Evaluation Considerations for Laptop, Notebook, Netbook and Tablet Computers, FCC KDB Publication 616217 D04
- [30] FCC SAR Measurement and Reporting Requirements for 100MHz – 6 GHz, KDB Publications 865664 D01-D02
- [31] FCC General RF Exposure Guidance and SAR Procedures for Dongles, KDB Publication 447498, D01-D02
- [32] Anexo à Resolução No. 533, de 10 de Setembro de 2009.
- [33] IEC 62209-2, Human exposure to radio frequency fields from hand-held and body-mounted wireless communication devices - Human models, instrumentation, and procedures - Part 2: Procedure to determine the specific absorption rate (SAR) for wireless communication devices used in close proximity to the human body (frequency range of 30 MHz to 6 GHz), Mar. 2010.

| | | | |
|-----------------------------------|---|-------------------------------|---|
| FCC ID: A3LGTS6790E |  | SAR EVALUATION REPORT |  Reviewed by: Quality Manager |
| Document S/N: OY1310312083.A3L | Test Dates: 11/04/13 - 11/06/13 | DUT Type: Portable Handset | Page 35 of 35 |

APPENDIX A: SAR TEST DATA

PCTEST ENGINEERING LABORATORY, INC.

DUT: A3LGTS6790E; Type: Portable Handset; Serial: FK-331-A

Communication System: GSM; Frequency: 836.6 MHz; Duty Cycle: 1:8.3

Medium: 835 Head Medium parameters used (interpolated):

$f = 836.6 \text{ MHz}$; $\sigma = 0.919 \text{ S/m}$; $\epsilon_r = 41.112$; $\rho = 1000 \text{ kg/m}^3$

Phantom section: Left Section

Test Date: 11-04-2013; Ambient Temp: 21.9°C; Tissue Temp: 21.6°C

Probe: ES3DV2 - SN3022; ConvF(6.09, 6.09, 6.09); Calibrated: 8/22/2013;

Sensor-Surface: 4mm (Mechanical Surface Detection)

Electronics: DAE4 Sn1322; Calibrated: 8/21/2013

Phantom: SAM v5.0 front; Type: QD000P40CD; Serial: TP-1646

Measurement SW: DASY52, Version 52.8 (7); SEMCAD X Version 14.6.10 (7164)

Mode: GSM 850, Left Head, Cheek, Mid.ch

Area Scan (7x11x1): Measurement grid: dx=15mm, dy=15mm

Zoom Scan (5x5x7)/Cube 0: Measurement grid: dx=8mm, dy=8mm, dz=5mm

Reference Value = 19.964 V/m; Power Drift = 0.02 dB

Peak SAR (extrapolated) = 0.436 W/kg

SAR(1 g) = 0.353 W/kg

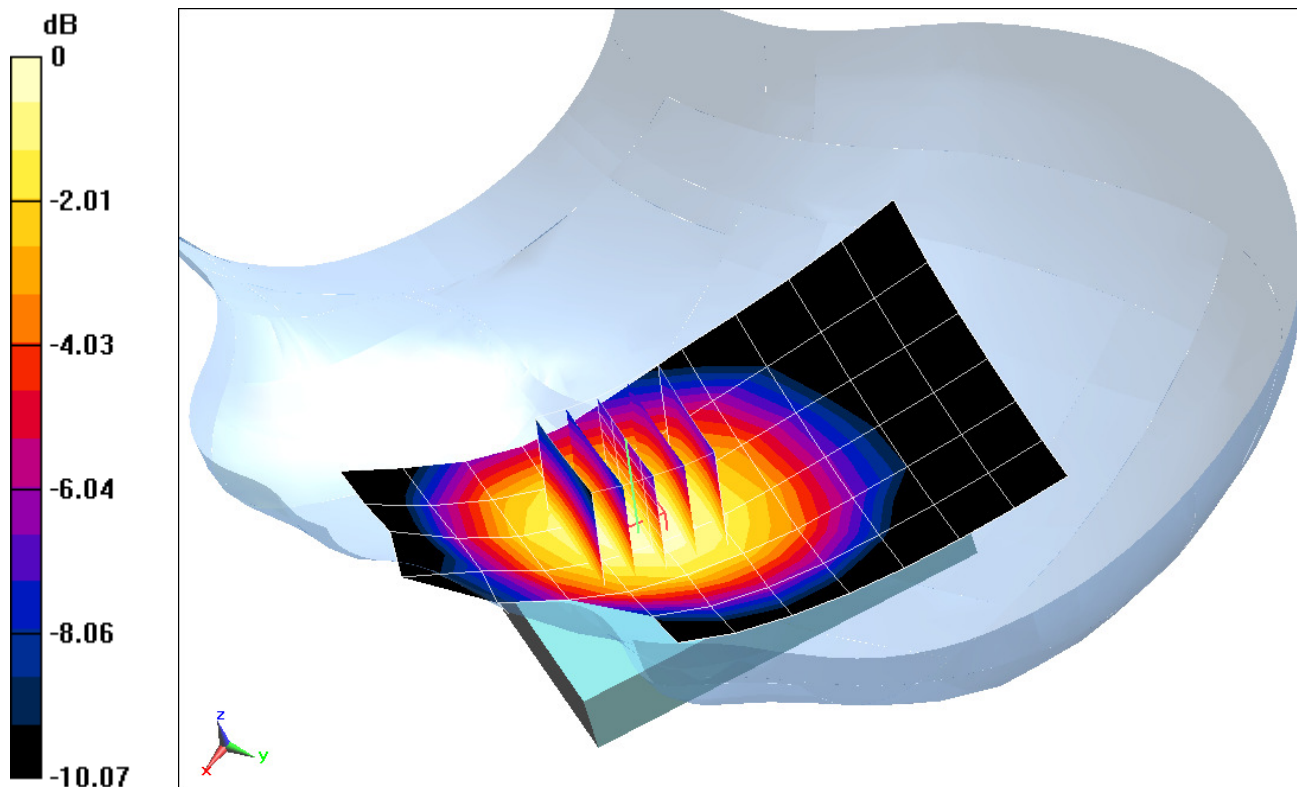

0 dB = 0.371 W/kg = -4.31 dBW/kg

PCTEST ENGINEERING LABORATORY, INC.

DUT: A3LGTS6790E; Type: Portable Handset; Serial: FK-331-A

Communication System: GSM; Frequency: 1880 MHz; Duty Cycle: 1:8.3

Medium: 1900 Head Medium parameters used:

$f = 1880 \text{ MHz}$; $\sigma = 1.426 \text{ S/m}$; $\epsilon_r = 39.937$; $\rho = 1000 \text{ kg/m}^3$

Phantom section: Left Section

Test Date: 11-06-2013; Ambient Temp: 24.5°C; Tissue Temp: 23.0°C

Probe: ES3DV3 - SN3209; ConvF(5.21, 5.21, 5.21); Calibrated: 3/15/2013;

Sensor-Surface: 4mm (Mechanical Surface Detection)

Electronics: DAE4 Sn1334; Calibrated: 3/8/2013

Phantom: SAM Front; Type: SAM; Serial: 1715

Measurement SW: DASY52, Version 52.8 (7); SEMCAD X Version 14.6.10 (7164)

Mode: GSM 1900, Left Head, Cheek, Mid.ch

Area Scan (7x11x1): Measurement grid: dx=15mm, dy=15mm

Zoom Scan (5x5x7)/Cube 0: Measurement grid: dx=8mm, dy=8mm, dz=5mm

Reference Value = 15.717 V/m; Power Drift = 0.02 dB

Peak SAR (extrapolated) = 0.724 W/kg

SAR(1 g) = 0.424 W/kg

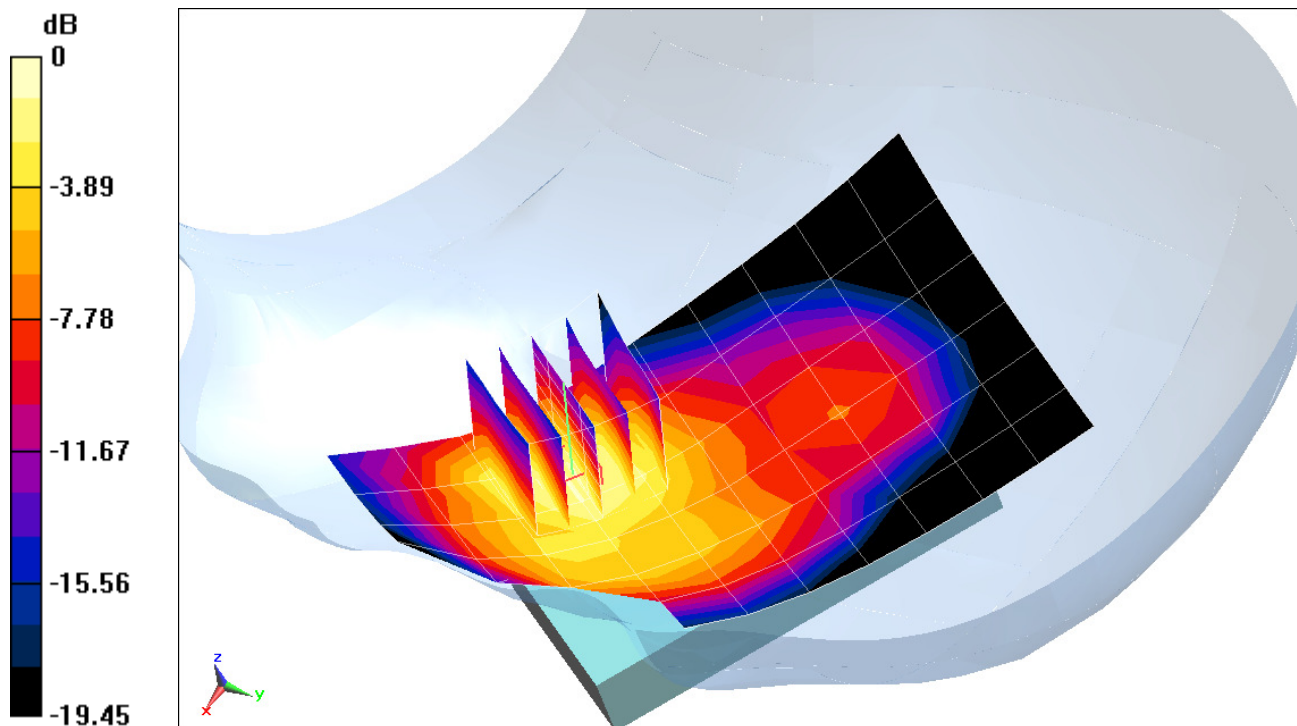

0 dB = 0.477 W/kg = -3.21 dBW/kg

PCTEST ENGINEERING LABORATORY, INC.

DUT: A3LGTS6790E; Type: Portable Handset; Serial: FK-331-A

Communication System: UMTS; Frequency: 1880 MHz; Duty Cycle: 1:1

Medium: 1900 Head Medium parameters used:

$f = 1880 \text{ MHz}$; $\sigma = 1.426 \text{ S/m}$; $\epsilon_r = 39.937$; $\rho = 1000 \text{ kg/m}^3$

Phantom section: Left Section

Test Date: 11-06-2013; Ambient Temp: 24.5°C; Tissue Temp: 23.0°C

Probe: ES3DV3 - SN3209; ConvF(5.21, 5.21, 5.21); Calibrated: 3/15/2013;

Sensor-Surface: 4mm (Mechanical Surface Detection)

Electronics: DAE4 Sn1334; Calibrated: 3/8/2013

Phantom: SAM Front; Type: SAM; Serial: 1715

Measurement SW: DASYS2, Version 52.8 (7); SEMCAD X Version 14.6.10 (7164)

Mode: UMTS 1900, Left Head, Cheek, Mid.ch

Area Scan (7x11x1): Measurement grid: dx=15mm, dy=15mm

Zoom Scan (5x5x7)/Cube 0: Measurement grid: dx=8mm, dy=8mm, dz=5mm

Reference Value = 20.202 V/m; Power Drift = -0.07 dB

Peak SAR (extrapolated) = 1.08 W/kg

SAR(1 g) = 0.632 W/kg

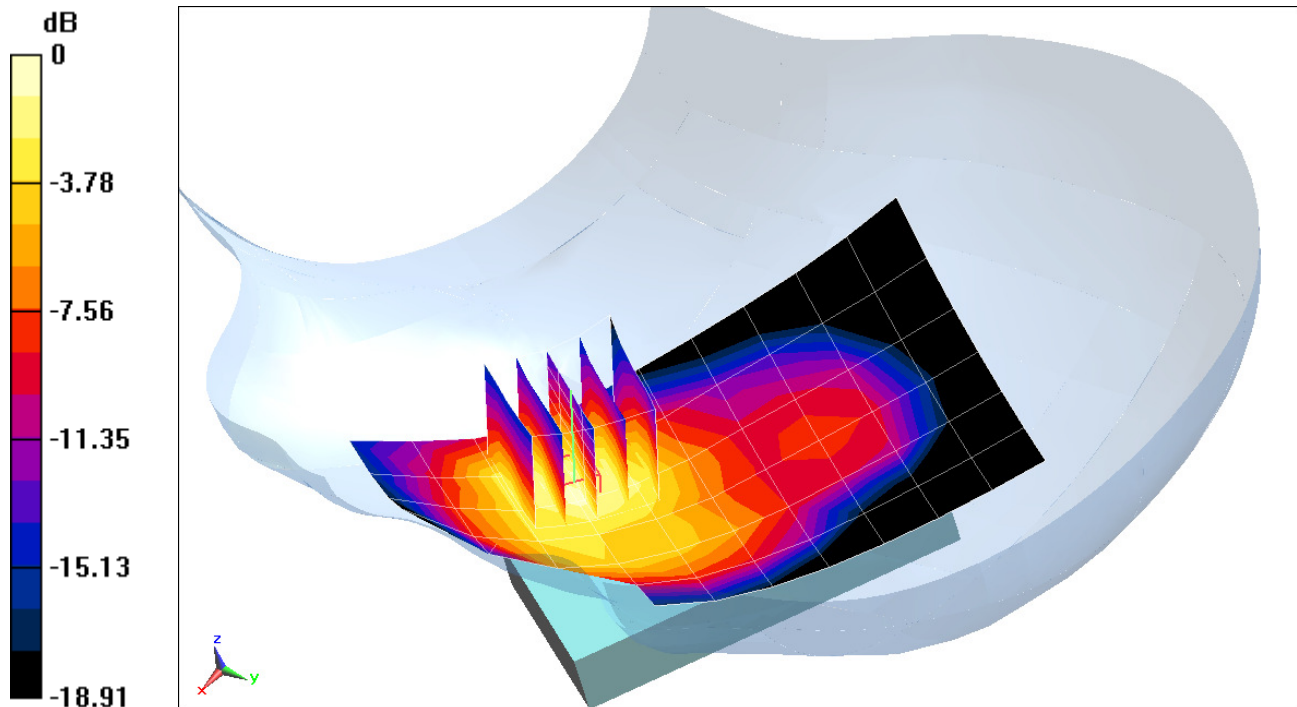

0 dB = 0.707 W/kg = -1.51 dBW/kg

PCTEST ENGINEERING LABORATORY, INC.

DUT: A3LGTS6790E; Type: Portable Handset; Serial: FK-331-A

Communication System: IEEE 802.11b; Frequency: 2462 MHz; Duty Cycle: 1:1

Medium: 2450 Head Medium parameters used (interpolated):

$f = 2462 \text{ MHz}$; $\sigma = 1.837 \text{ S/m}$; $\epsilon_r = 40.772$; $\rho = 1000 \text{ kg/m}^3$

Phantom section: Right Section

Test Date: 11-04-2013; Ambient Temp: 21.3°C; Tissue Temp: 20.9°C

Probe: ES3DV3 - SN3209; ConvF(4.57, 4.57, 4.57); Calibrated: 3/15/2013;

Sensor-Surface: 3mm (Mechanical Surface Detection)

Electronics: DAE4 Sn1334; Calibrated: 3/8/2013

Phantom: SAM Right; Type: QD000P40CD; Serial: 1686

Measurement SW: DASY52, Version 52.8 (7); SEMCAD X Version 14.6.10 (7164)

Mode: IEEE 802.11b, Right Head, Cheek, Ch 11, 1 Mbps

Area Scan (9x15x1): Measurement grid: dx=12mm, dy=12mm

Zoom Scan (7x7x7)/Cube 0: Measurement grid: dx=5mm, dy=5mm, dz=5mm

Reference Value = 19.891 V/m; Power Drift = 0.06 dB

Peak SAR (extrapolated) = 1.07 W/kg

SAR(1 g) = 0.580 W/kg

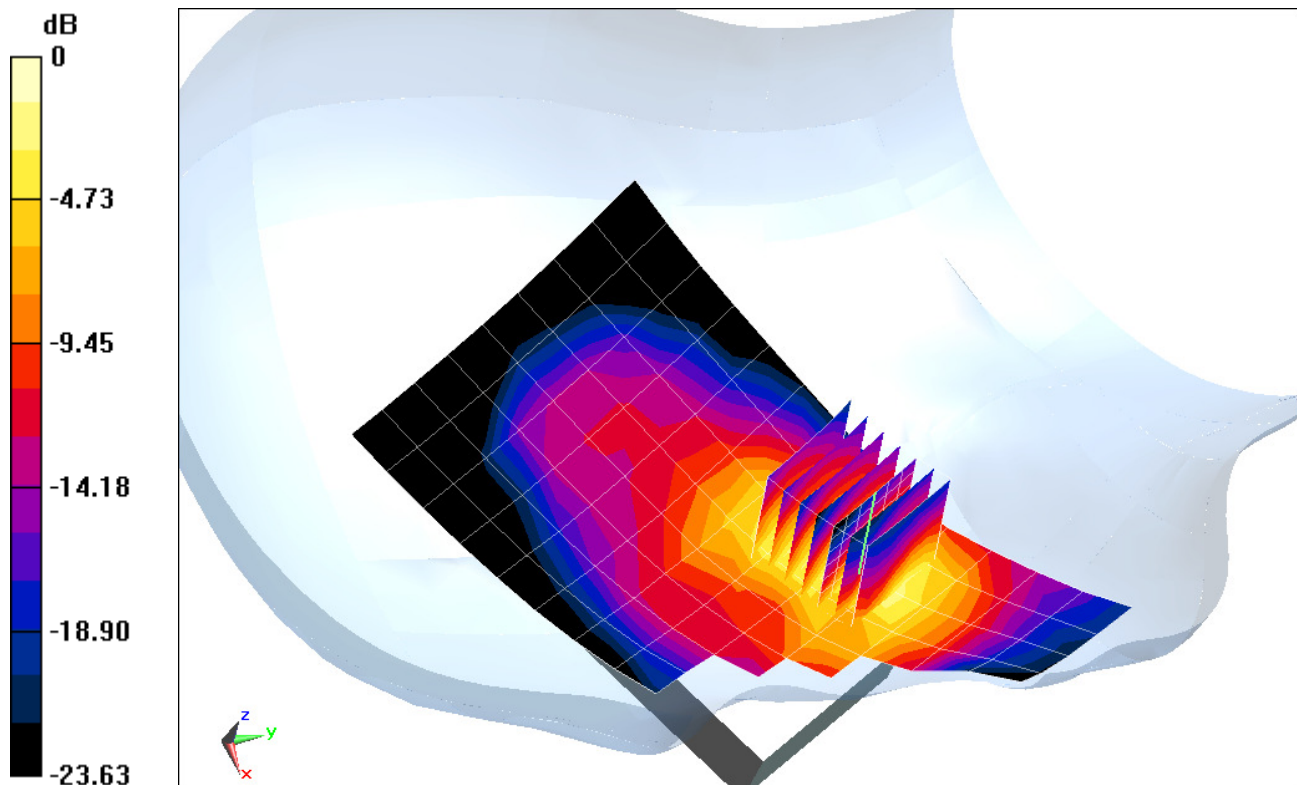

0 dB = 0.767 W/kg = -1.15 dBW/kg

PCTEST ENGINEERING LABORATORY, INC.

DUT: A3LGTS6790E; Type: Portable Handset; Serial: FK-331-A

Communication System: GSM; Frequency: 836.6 MHz; Duty Cycle: 1:8.3

Medium: 835 Body Medium parameters used (interpolated):

$f = 836.6 \text{ MHz}$; $\sigma = 1.001 \text{ S/m}$; $\epsilon_r = 53.696$; $\rho = 1000 \text{ kg/m}^3$

Phantom section: Flat Section; Space: 1.0 cm

Test Date: 11-04-2013; Ambient Temp: 21.7°C; Tissue Temp: 21.0°C

Probe: ES3DV3 - SN3318; ConvF(6.21, 6.21, 6.21); Calibrated: 4/29/2013;

Sensor-Surface: 4mm (Mechanical Surface Detection)

Electronics: DAE4 Sn1364; Calibrated: 4/22/2013

Phantom: ELI left; Type: QDOVA002AA; Serial: TP:1202

Measurement SW: DASY52, Version 52.8 (7); SEMCAD X Version 14.6.10 (7164)

Mode: GSM 850, Body SAR, Back side, Mid.ch

Area Scan (7x12x1): Measurement grid: dx=15mm, dy=15mm

Zoom Scan (5x5x7)/Cube 0: Measurement grid: dx=8mm, dy=8mm, dz=5mm

Reference Value = 25.037 V/m; Power Drift = 0.00 dB

Peak SAR (extrapolated) = 0.767 W/kg

SAR(1 g) = 0.575 W/kg

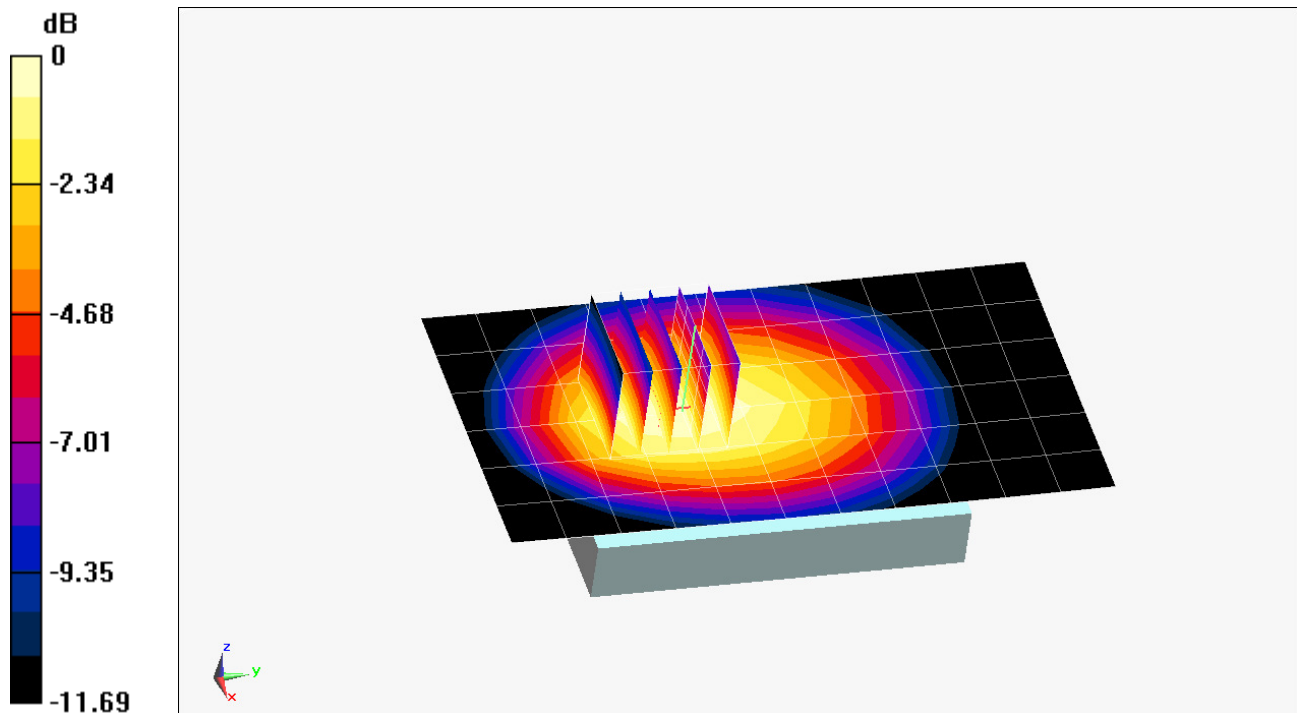

0 dB = 0.608 W/kg = -2.16 dBW/kg

PCTEST ENGINEERING LABORATORY, INC.

DUT: A3LGTS6790E; Type: Portable Handset; Serial: FK-331-A

Communication System: GSM GPRS; 4 Tx slots; Frequency: 836.6 MHz; Duty Cycle: 1:2.076

Medium: 835 Body Medium parameters used (interpolated):

$f = 836.6 \text{ MHz}$; $\sigma = 1.001 \text{ S/m}$; $\epsilon_r = 53.696$; $\rho = 1000 \text{ kg/m}^3$

Phantom section: Flat Section; Space: 1.0 cm

Test Date: 11-04-2013; Ambient Temp: 21.7°C; Tissue Temp: 21.0°C

Probe: ES3DV3 - SN3318; ConvF(6.21, 6.21, 6.21); Calibrated: 4/29/2013;

Sensor-Surface: 4mm (Mechanical Surface Detection)

Electronics: DAE4 Sn1364; Calibrated: 4/22/2013

Phantom: ELI left; Type: QDOVA002AA; Serial: TP:1202

Measurement SW: DASY52, Version 52.8 (7); SEMCAD X Version 14.6.10 (7164)

Mode: GPRS 850, Body SAR, Back side, Mid.ch, 4 Tx Slots

Area Scan (7x12x1): Measurement grid: dx=15mm, dy=15mm

Zoom Scan (5x5x7)/Cube 0: Measurement grid: dx=8mm, dy=8mm, dz=5mm

Reference Value = 24.898 V/m; Power Drift = 0.00 dB

Peak SAR (extrapolated) = 0.761 W/kg

SAR(1 g) = 0.571 W/kg

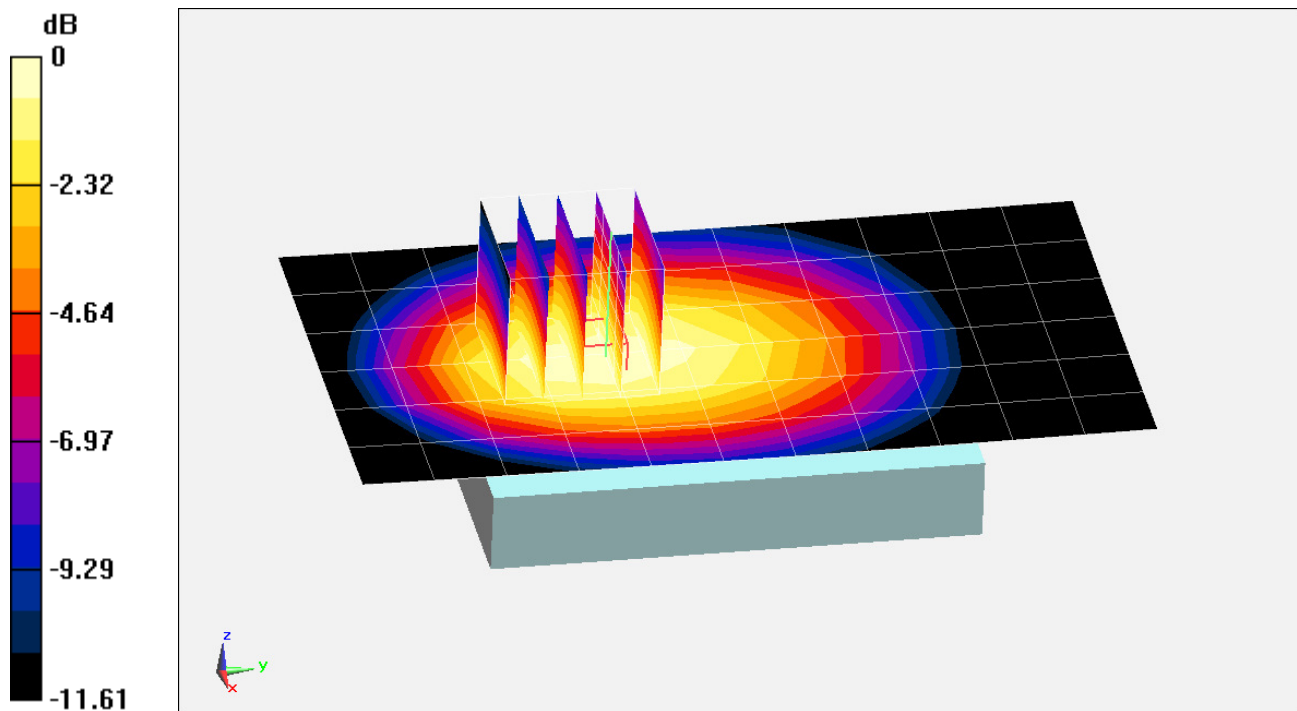

0 dB = 0.603 W/kg = -2.20 dBW/kg

PCTEST ENGINEERING LABORATORY, INC.

DUT: A3LGTS6790E; Type: Portable Handset; Serial: FK-331-A

Communication System: GSM; Frequency: 1880 MHz; Duty Cycle: 1:8.3

Medium: 1900 Body Medium parameters used:

$f = 1880 \text{ MHz}$; $\sigma = 1.512 \text{ S/m}$; $\epsilon_r = 52.414$; $\rho = 1000 \text{ kg/m}^3$

Phantom section: Flat Section; Space: 1.0 cm

Test Date: 11-04-2013; Ambient Temp: 23.4°C; Tissue Temp: 22.3°C

Probe: ES3DV3 - SN3319; ConvF(4.85, 4.85, 4.85); Calibrated: 4/29/2013;

Sensor-Surface: 4mm (Mechanical Surface Detection)

Electronics: DAE4 Sn1368; Calibrated: 4/22/2013

Phantom: SAM right; Type: QD000P40CD; Serial: TP:1757

Measurement SW: DASY52, Version 52.8 (7); SEMCAD X Version 14.6.10 (7164)

Mode: GSM 1900, Body SAR, Back side, Mid.ch

Area Scan (7x10x1): Measurement grid: dx=15mm, dy=15mm

Zoom Scan (5x5x7)/Cube 0: Measurement grid: dx=8mm, dy=8mm, dz=5mm

Reference Value = 15.674 V/m; Power Drift = -0.03 dB

Peak SAR (extrapolated) = 0.547 W/kg

SAR(1 g) = 0.342 W/kg

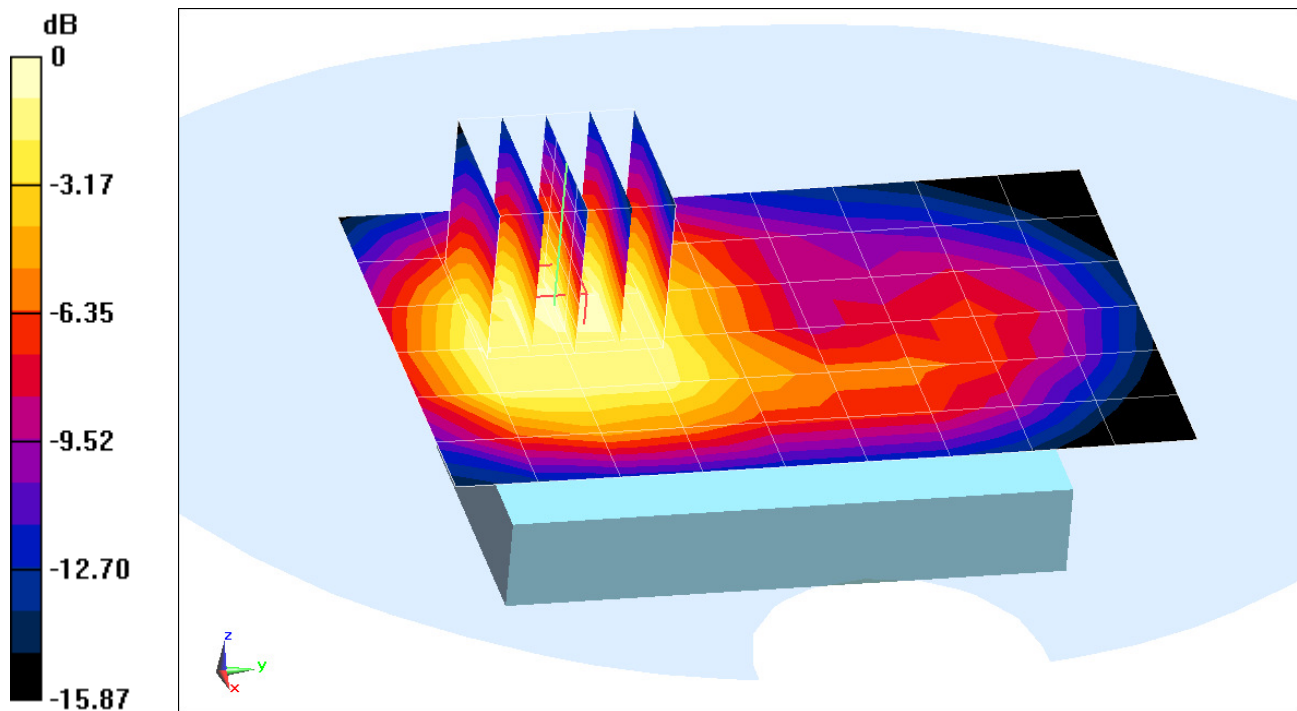

0 dB = 0.371 W/kg = -4.31 dBW/kg

PCTEST ENGINEERING LABORATORY, INC.

DUT: A3LGTS6790E; Type: Portable Handset; Serial: FK-331-A

Communication System: GSM GPRS; 4 Tx slots; Frequency: 1880 MHz; Duty Cycle: 1:2.076

Medium: 1900 Body Medium parameters used:

$f = 1880 \text{ MHz}$; $\sigma = 1.512 \text{ S/m}$; $\epsilon_r = 52.414$; $\rho = 1000 \text{ kg/m}^3$

Phantom section: Flat Section; Space: 1.0 cm

Test Date: 11-04-2013; Ambient Temp: 23.4°C; Tissue Temp: 22.3°C

Probe: ES3DV3 - SN3319; ConvF(4.85, 4.85, 4.85); Calibrated: 4/29/2013;

Sensor-Surface: 4mm (Mechanical Surface Detection)

Electronics: DAE4 Sn1368; Calibrated: 4/22/2013

Phantom: SAM right; Type: QD000P40CD; Serial: TP:1757

Measurement SW: DASY52, Version 52.8 (7); SEMCAD X Version 14.6.10 (7164)

Mode: GPRS 1900, Body SAR, Back side, Mid.ch, 4 Tx Slots

Area Scan (7x10x1): Measurement grid: dx=15mm, dy=15mm

Zoom Scan (5x5x7)/Cube 0: Measurement grid: dx=8mm, dy=8mm, dz=5mm

Reference Value = 17.749 V/m; Power Drift = -0.02 dB

Peak SAR (extrapolated) = 0.718 W/kg

SAR(1 g) = 0.444 W/kg

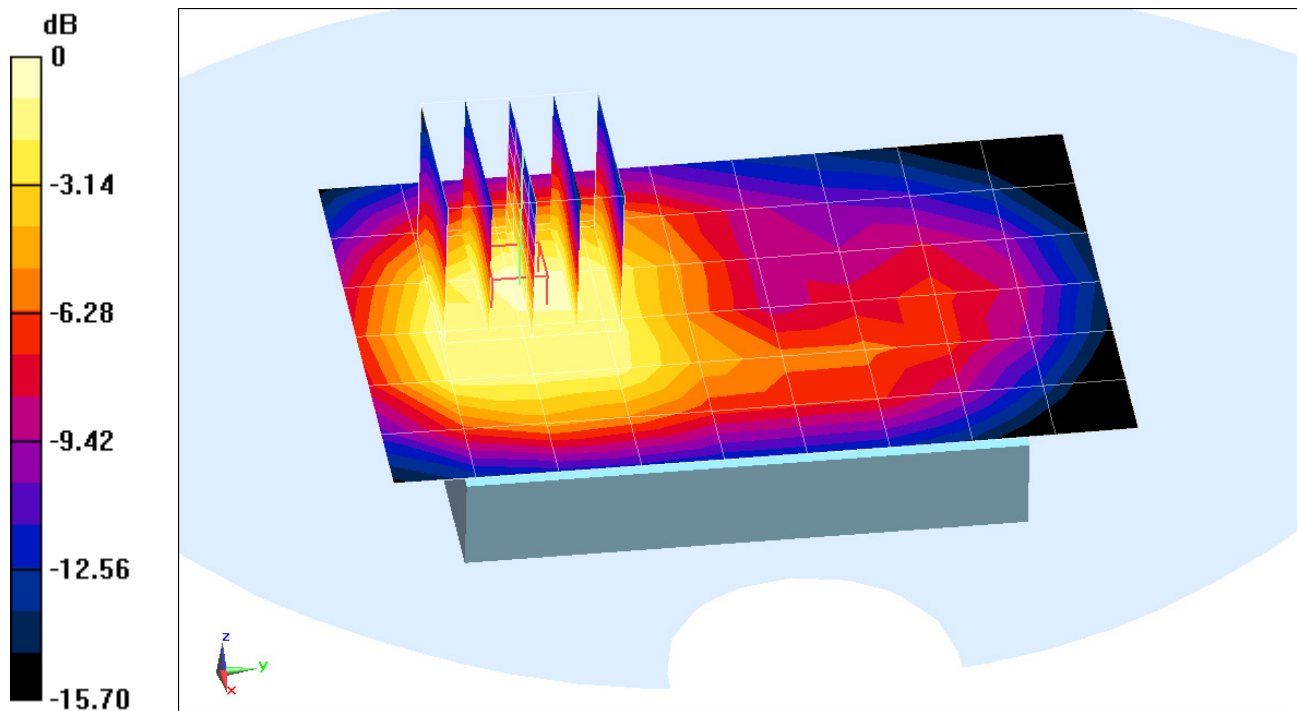

0 dB = 0.484 W/kg = -3.15 dBW/kg

PCTEST ENGINEERING LABORATORY, INC.

DUT: A3LGTS6790E; Type: Portable Handset; Serial: FK-331-B

Communication System: UMTS; Frequency: 1880 MHz; Duty Cycle: 1:1

Medium: 1900 Body Medium parameters used:

$f = 1880 \text{ MHz}$; $\sigma = 1.512 \text{ S/m}$; $\epsilon_r = 52.414$; $\rho = 1000 \text{ kg/m}^3$

Phantom section: Flat Section; Space: 1.0 cm

Test Date: 11-04-2013; Ambient Temp: 23.4°C; Tissue Temp: 22.3°C

Probe: ES3DV3 - SN3319; ConvF(4.85, 4.85, 4.85); Calibrated: 4/29/2013;

Sensor-Surface: 4mm (Mechanical Surface Detection)

Electronics: DAE4 Sn1368; Calibrated: 4/22/2013

Phantom: SAM right; Type: QD000P40CD; Serial: TP:1757

Measurement SW: DASY52, Version 52.8 (7); SEMCAD X Version 14.6.10 (7164)

Mode: UMTS 1900, Body SAR, Back side, Mid.ch

Area Scan (7x10x1): Measurement grid: dx=15mm, dy=15mm

Zoom Scan (5x5x7)/Cube 0: Measurement grid: dx=8mm, dy=8mm, dz=5mm

Reference Value = 18.376 V/m; Power Drift = -0.01 dB

Peak SAR (extrapolated) = 0.812 W/kg

SAR(1 g) = 0.506 W/kg

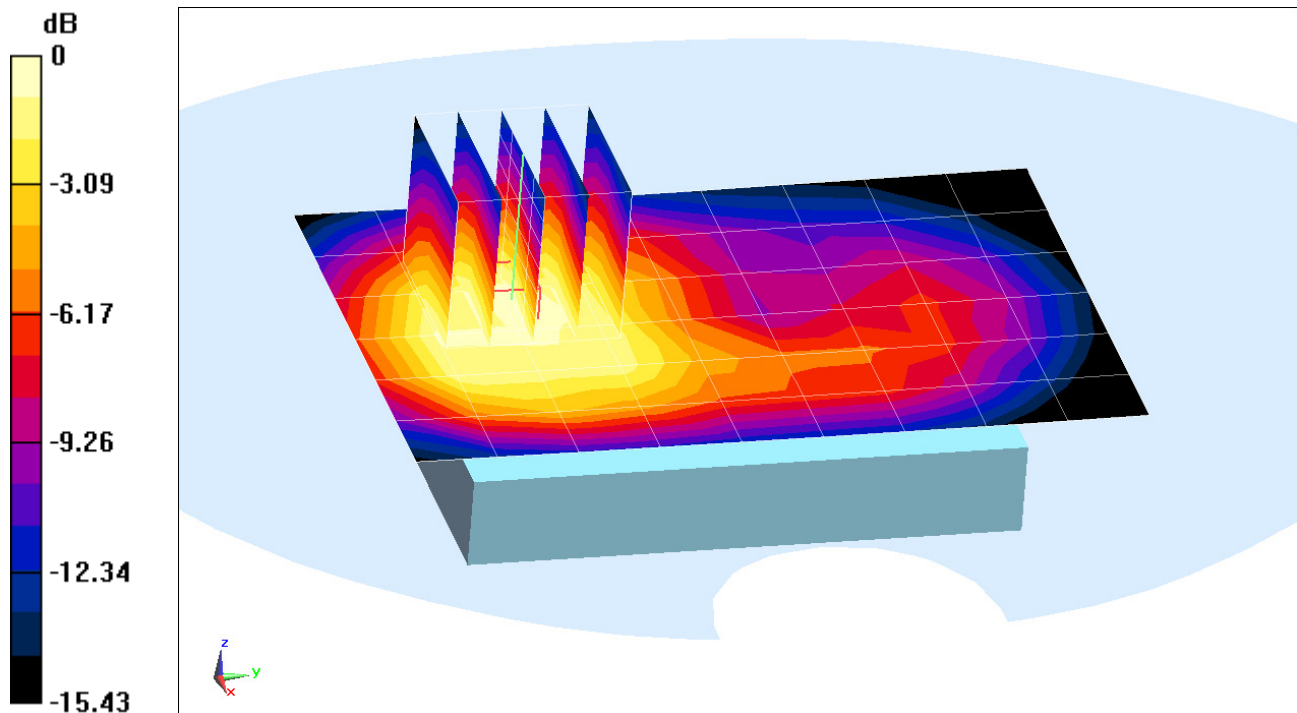

0 dB = 0.551 W/kg = -2.59 dBW/kg

PCTEST ENGINEERING LABORATORY, INC.

DUT: A3LGTS6790E; Type: Portable Handset; Serial: FK-331-B

Communication System: IEEE 802.11b; Frequency: 2462 MHz; Duty Cycle: 1:1

Medium: 2450 Body Medium parameters used (interpolated):

$f = 2462 \text{ MHz}$; $\sigma = 1.969 \text{ S/m}$; $\epsilon_r = 53.027$; $\rho = 1000 \text{ kg/m}^3$

Phantom section: Flat Section; Space: 1.0 cm

Test Date: 11-04-2013; Ambient Temp: 22.3°C; Tissue Temp: 22.4°C

Probe: ES3DV3 - SN3263; ConvF(4.33, 4.33, 4.33); Calibrated: 5/16/2013;

Sensor-Surface: 3mm (Mechanical Surface Detection)

Electronics: DAE4 Sn859; Calibrated: 5/13/2013

Phantom: SAM Main; Type: SAM 4.0; Serial: TP-1406

Measurement SW: DASY4, Version 4.7 (80); SEMCAD X Version 14.6.10 (7164)

Mode: IEEE 802.11b, Body SAR, Ch 11, 1 Mbps, Back Side

Area Scan (8x13x1): Measurement grid: dx=12mm, dy=12mm

Zoom Scan (7x7x7)/Cube 0: Measurement grid: dx=5mm, dy=5mm, dz=5mm

Reference Value = 10.758 V/m; Power Drift = 0.03 dB

Peak SAR (extrapolated) = 0.476 W/kg

SAR(1 g) = 0.237 W/kg

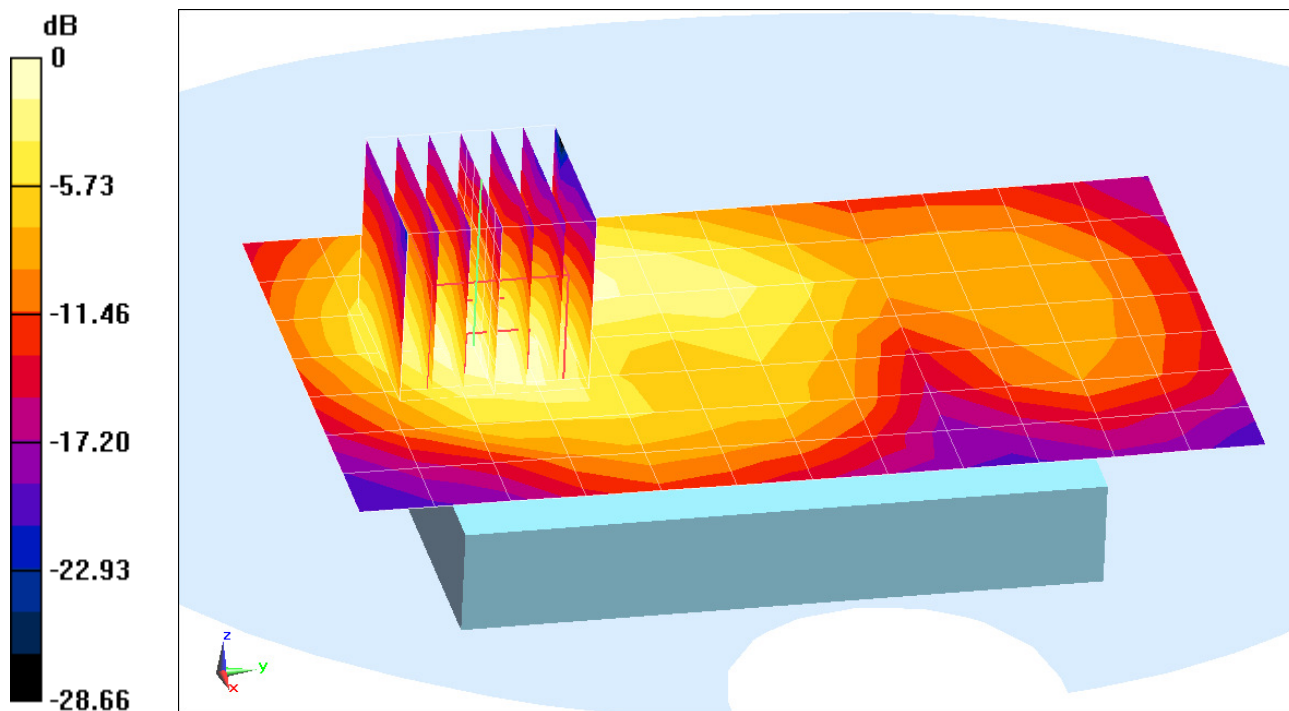

0 dB = 0.297 W/kg = -5.27 dBW/kg

PCTEST ENGINEERING LABORATORY, INC.

DUT: A3LGTS6790E; Type: Portable Handset; Serial: FK-331-B

Communication System: IEEE 802.11b; Frequency: 2462 MHz; Duty Cycle: 1:1

Medium: 2450 Body Medium parameters used (interpolated):

$f = 2462 \text{ MHz}$; $\sigma = 1.969 \text{ S/m}$; $\epsilon_r = 53.027$; $\rho = 1000 \text{ kg/m}^3$

Phantom section: Flat Section; Space: 1.0 cm

Test Date: 11-04-2013; Ambient Temp: 22.3°C; Tissue Temp: 22.4°C

Probe: ES3DV3 - SN3263; ConvF(4.33, 4.33, 4.33); Calibrated: 5/16/2013;

Sensor-Surface: 3mm (Mechanical Surface Detection)

Electronics: DAE4 Sn859; Calibrated: 5/13/2013

Phantom: SAM Main; Type: SAM 4.0; Serial: TP-1406

Measurement SW: DASY4, Version 4.7 (80); SEMCAD X Version 14.6.10 (7164)

Mode: IEEE 802.11b, Body SAR, Ch 11, 1 Mbps, Front Side

Area Scan (8x14x1): Measurement grid: dx=12mm, dy=12mm

Zoom Scan (7x7x7)/Cube 0: Measurement grid: dx=5mm, dy=5mm, dz=5mm

Reference Value = 12.010 V/m; Power Drift = -0.01 dB

Peak SAR (extrapolated) = 0.578 W/kg

SAR(1 g) = 0.271 W/kg

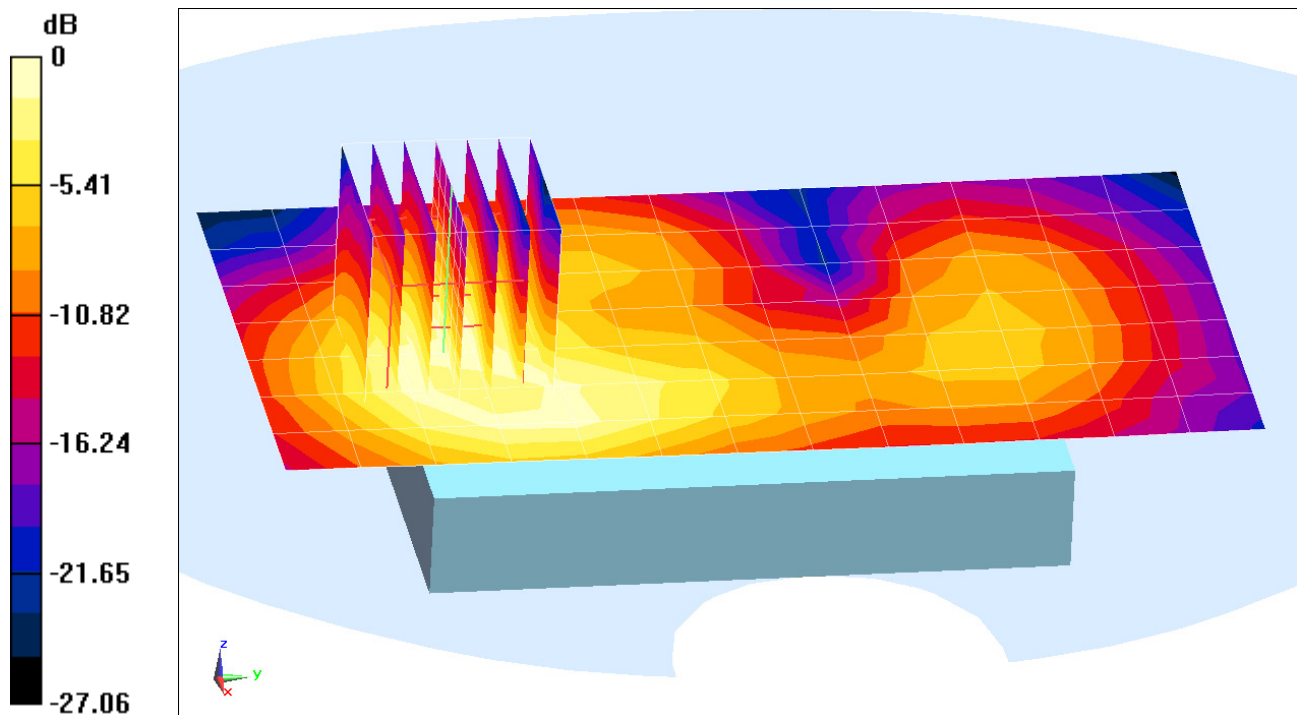

0 dB = 0.347 W/kg = -4.60 dBW/kg

APPENDIX B: SYSTEM VERIFICATION

PCTEST ENGINEERING LABORATORY, INC.

DUT: SAR Dipole 835 MHz; Type: D835V2; Serial: 4d119

Communication System: CW; Frequency: 835 MHz; Duty Cycle: 1:1

Medium: 835 Head Medium parameters used:

$f = 835 \text{ MHz}$; $\sigma = 0.917 \text{ S/m}$; $\epsilon_r = 41.142$; $\rho = 1000 \text{ kg/m}^3$

Phantom section: Flat Section; Space: 1.5 cm

Test Date: 11-04-2013; Ambient Temp: 21.9°C; Tissue Temp: 21.6°C

Probe: ES3DV2 - SN3022; ConvF(6.09, 6.09, 6.09); Calibrated: 8/22/2013;

Sensor-Surface: 4mm (Mechanical Surface Detection)

Electronics: DAE4 Sn1322; Calibrated: 8/21/2013

Phantom: SAM v5.0 front; Type: QD000P40CD; Serial: TP-1646

Measurement SW: DASY52, Version 52.8 (7); SEMCAD X Version 14.6.10 (7164)

835 MHz System Verification

Area Scan (7x14x1): Measurement grid: dx=15mm, dy=15mm

Zoom Scan (5x5x7)/Cube 0: Measurement grid: dx=8mm, dy=8mm, dz=5mm

Input Power = 20.0 dBm (100 mW)

Peak SAR (extrapolated) = 1.45 W/kg

SAR(1 g) = 0.988 W/kg

Deviation = 2.07%

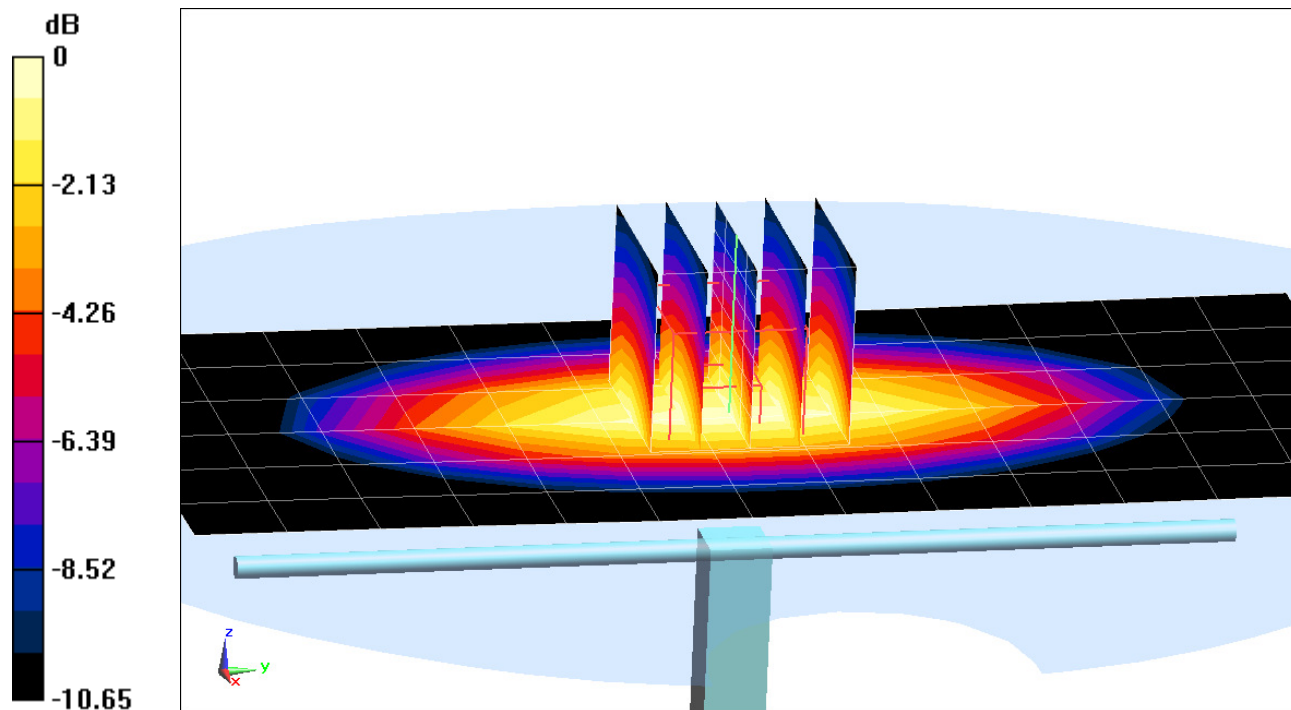

0 dB = 1.07 W/kg = 0.29 dBW/kg

PCTEST ENGINEERING LABORATORY, INC.

DUT: SAR Dipole 1900 MHz; Type: D1900V2; Serial: 5d148

Communication System: CW; Frequency: 1900 MHz; Duty Cycle: 1:1

Medium: 1900 Head Medium parameters used (interpolated):

$f = 1900 \text{ MHz}$; $\sigma = 1.446 \text{ S/m}$; $\epsilon_r = 39.852$; $\rho = 1000 \text{ kg/m}^3$

Phantom section: Flat Section; Space: 1.0 cm

Test Date: 11-06-2013; Ambient Temp: 24.5°C; Tissue Temp: 23.0°C

Probe: ES3DV3 - SN3209; ConvF(5.21, 5.21, 5.21); Calibrated: 3/15/2013;

Sensor-Surface: 4mm (Mechanical Surface Detection)

Electronics: DAE4 Sn1334; Calibrated: 3/8/2013

Phantom: SAM Front; Type: SAM; Serial: 1715

Measurement SW: DASY52, Version 52.8 (7); SEMCAD X Version 14.6.10 (7164)

1900 MHz System Verification

Area Scan (7x10x1): Measurement grid: dx=15mm, dy=15mm

Zoom Scan (5x5x7)/Cube 0: Measurement grid: dx=8mm, dy=8mm, dz=5mm

Input Power: 20.0 dBm (100 mW)

Peak SAR (extrapolated) = 7.39 W/kg

SAR(1 g) = 4 W/kg

Deviation = 0.76%

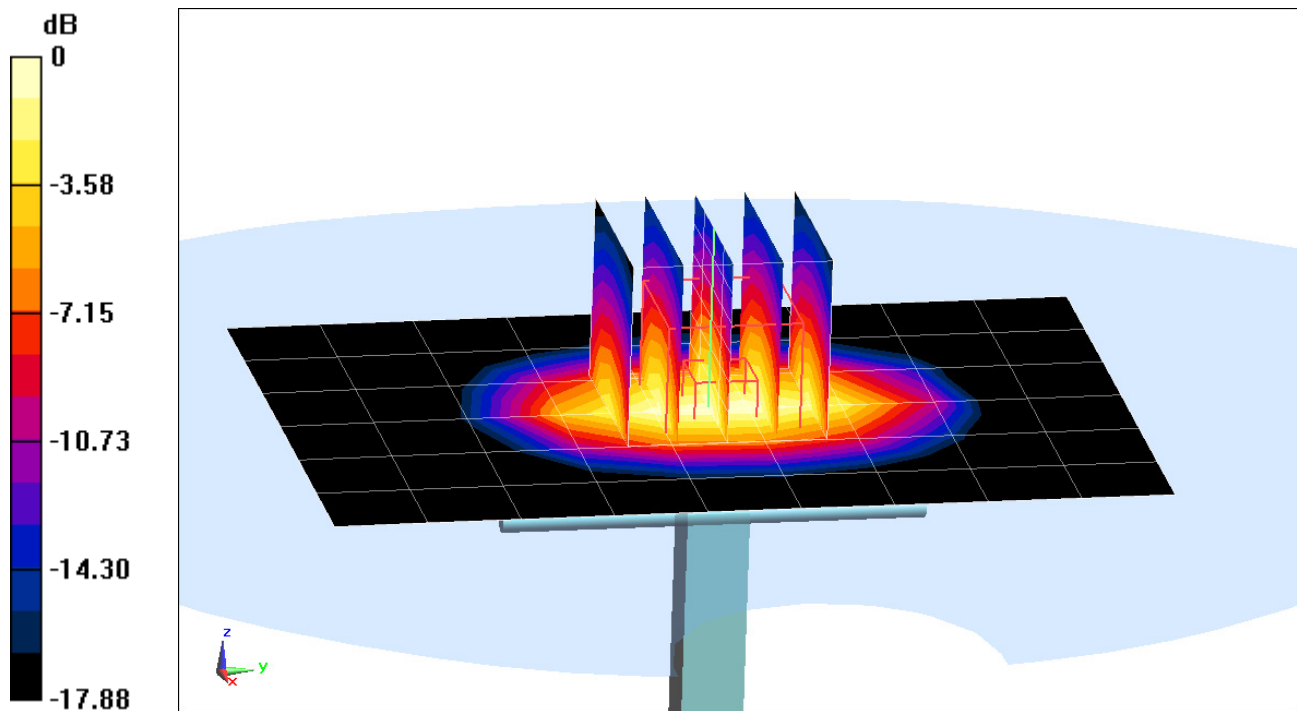

0 dB = 4.50 W/kg = 6.53 dBW/kg

PCTEST ENGINEERING LABORATORY, INC.

DUT: Dipole 2450 MHz; Type: D2450V2; Serial: 797

Communication System: CW; Frequency: 2450 MHz; Duty Cycle: 1:1

Medium: 2450 Head Medium parameters used:

$f = 2450 \text{ MHz}$; $\sigma = 1.824 \text{ S/m}$; $\epsilon_r = 40.815$; $\rho = 1000 \text{ kg/m}^3$

Phantom section: Flat Section; Space: 1.0 cm

Test Date: 11-04-2013; Ambient Temp: 21.3°C; Tissue Temp: 20.9°C

Probe: ES3DV3 - SN3209; ConvF(4.57, 4.57, 4.57); Calibrated: 3/15/2013;

Sensor-Surface: 3mm (Mechanical Surface Detection)

Electronics: DAE4 Sn1334; Calibrated: 3/8/2013

Phantom: SAM Right; Type: QD000P40CD; Serial: 1686

Measurement SW: DASY52, Version 52.8 (7); SEMCAD X Version 14.6.10 (7164)

2450 MHz System Validation

Area Scan (8x9x1): Measurement grid: dx=12mm, dy=12mm

Zoom Scan (7x7x7)/Cube 0: Measurement grid: dx=5mm, dy=5mm, dz=5mm

Input Power = 16.0 dBm (40 mW)

Peak SAR (extrapolated) = 4.28 W/kg

SAR(1 g) = 2.06 W/kg

Deviation = -1.09%

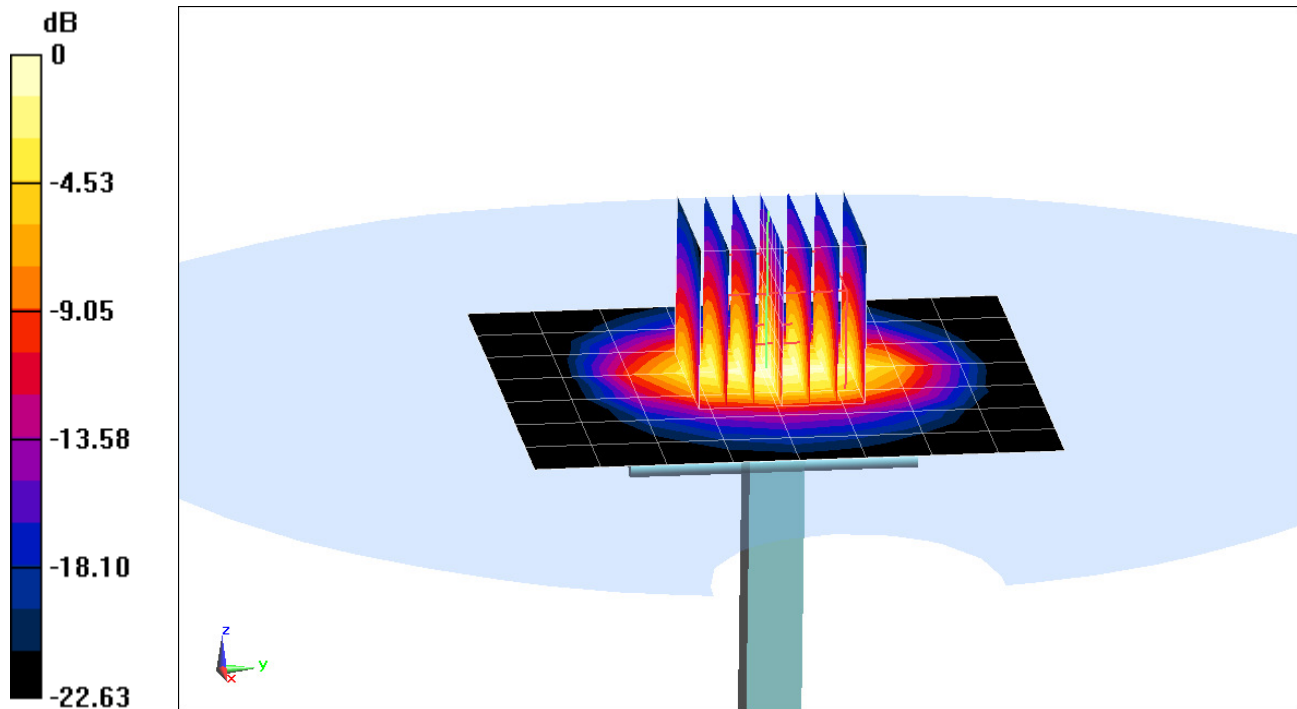

0 dB = 2.67 W/kg = 4.27 dBW/kg

PCTEST ENGINEERING LABORATORY, INC.

DUT: SAR Dipole 835 MHz; Type: D835V2; Serial: 4d119

Communication System: CW; Frequency: 835 MHz; Duty Cycle: 1:1

Medium: 835 Body Medium parameters used:

$f = 835 \text{ MHz}$; $\sigma = 0.999 \text{ S/m}$; $\epsilon_r = 53.709$; $\rho = 1000 \text{ kg/m}^3$

Phantom section: Flat Section; Space: 1.5 cm

Test Date: 11-04-2013; Ambient Temp: 21.7°C; Tissue Temp: 21.0°C

Probe: ES3DV3 - SN3318; ConvF(6.21, 6.21, 6.21); Calibrated: 4/29/2013;

Sensor-Surface: 4mm (Mechanical Surface Detection)

Electronics: DAE4 Sn1364; Calibrated: 4/22/2013

Phantom: ELI left; Type: QDOVA002AA; Serial: TP:1202

Measurement SW: DASY52, Version 52.8 (7); SEMCAD X Version 14.6.10 (7164)

835 MHz System Verification

Area Scan (7x14x1): Measurement grid: dx=15mm, dy=15mm

Zoom Scan (5x5x7)/Cube 0: Measurement grid: dx=8mm, dy=8mm, dz=5mm

Input Power = 20.0 dBm (100 mW)

Peak SAR (extrapolated) = 1.45 W/kg

SAR(1 g) = 0.997 W/kg

Deviation = 4.51%

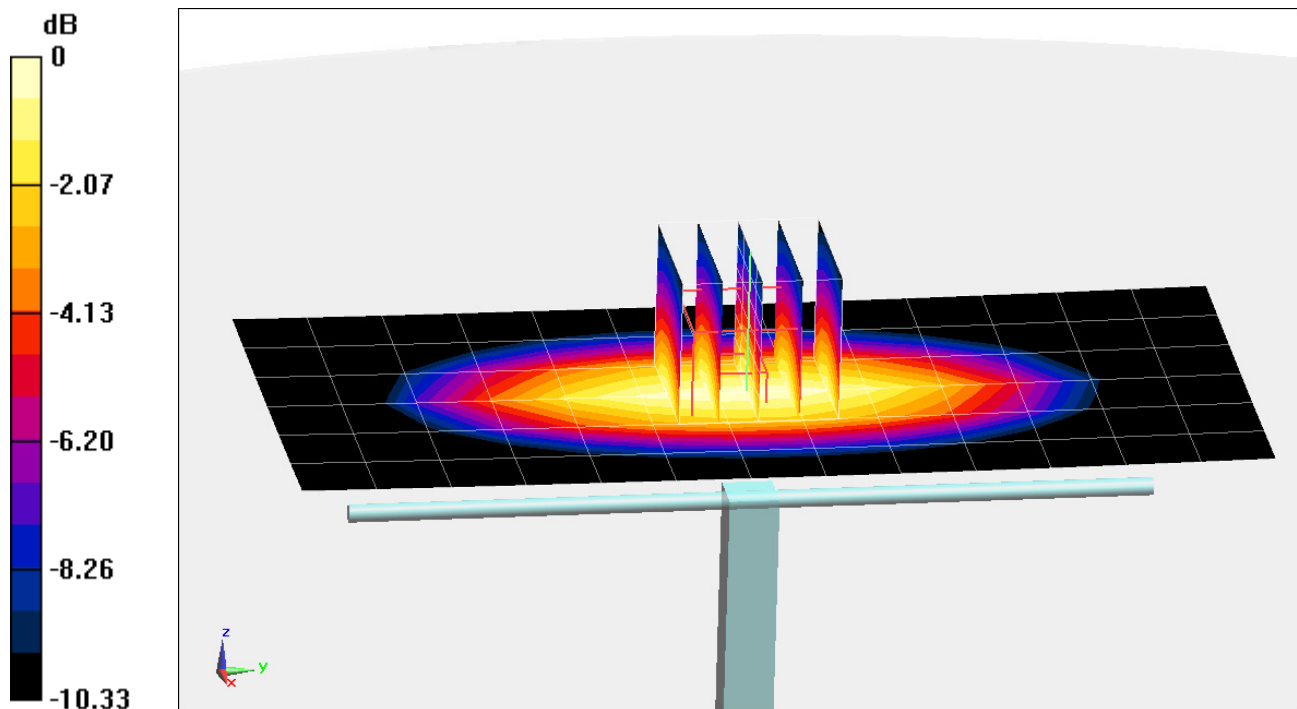

0 dB = 1.08 W/kg = 0.33 dBW/kg

PCTEST ENGINEERING LABORATORY, INC.

DUT: SAR Dipole 1900 MHz; Type: D1900V2; Serial: 5d148

Communication System: CW; Frequency: 1900 MHz; Duty Cycle: 1:1

Medium: 1900 Body Medium parameters used (interpolated):

$f = 1900 \text{ MHz}$; $\sigma = 1.536 \text{ S/m}$; $\epsilon_r = 52.357$; $\rho = 1000 \text{ kg/m}^3$

Phantom section: Flat Section; Space: 1.0 cm

Test Date: 11-04-2013; Ambient Temp: 23.4°C; Tissue Temp: 22.3°C

Probe: ES3DV3 - SN3319; ConvF(4.85, 4.85, 4.85); Calibrated: 4/29/2013;

Sensor-Surface: 4mm (Mechanical Surface Detection)

Electronics: DAE4 Sn1368; Calibrated: 4/22/2013

Phantom: SAM right; Type: QD000P40CD; Serial: TP:1757

Measurement SW: DASY52, Version 52.8 (7); SEMCAD X Version 14.6.10 (7164)

1900 MHz System Verification

Area Scan (7x10x1): Measurement grid: dx=15mm, dy=15mm

Zoom Scan (7x7x7)/Cube 0: Measurement grid: dx=5mm, dy=5mm, dz=5mm

Input Power = 20.0 dBm (100 mW)

Peak SAR (extrapolated) = 7.01 W/kg

SAR(1 g) = 3.89 W/kg

Deviation = -4.66%

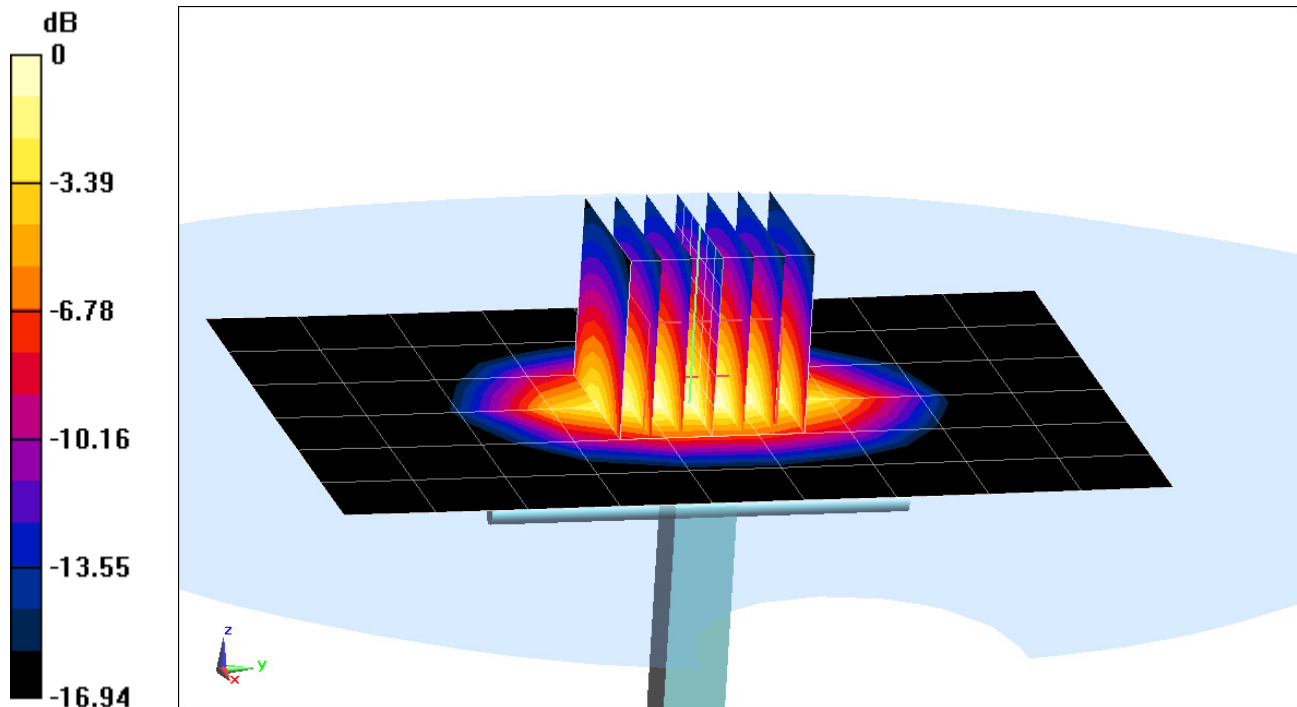

0 dB = 4.40 W/kg = 6.43 dBW/kg

PCTEST ENGINEERING LABORATORY, INC.

DUT: SAR Dipole 2450 MHz; Type: D2450V2; Serial: 882

Communication System: CW; Frequency: 2450 MHz; Duty Cycle: 1:1

Medium: 2450 Body Medium parameters used:

$f = 2450 \text{ MHz}$; $\sigma = 1.954 \text{ S/m}$; $\epsilon_r = 53.068$; $\rho = 1000 \text{ kg/m}^3$

Phantom section: Flat Section; Space: 1.0 cm

Test Date: 11-04-2013; Ambient Temp: 22.3°C; Tissue Temp: 22.4°C

Probe: ES3DV3 - SN3263; ConvF(4.33, 4.33, 4.33); Calibrated: 5/16/2013;

Sensor-Surface: 3mm (Mechanical Surface Detection)

Electronics: DAE4 Sn859; Calibrated: 5/13/2013

Phantom: SAM Main; Type: SAM 4.0; Serial: TP-1406

Measurement SW: DASY4, Version 4.7 (80); SEMCAD X Version 14.6.10 (7164)

2450MHz System Verification

Area Scan (6x9x1): Measurement grid: dx=12mm, dy=12mm

Zoom Scan (7x7x7)/Cube 0: Measurement grid: dx=5mm, dy=5mm, dz=5mm

Input Power = 20.0 dBm (100 mW)

Peak SAR (extrapolated) = 10.5 W/kg

SAR(1 g) = 4.94 W/kg

Deviation = - 1.00%

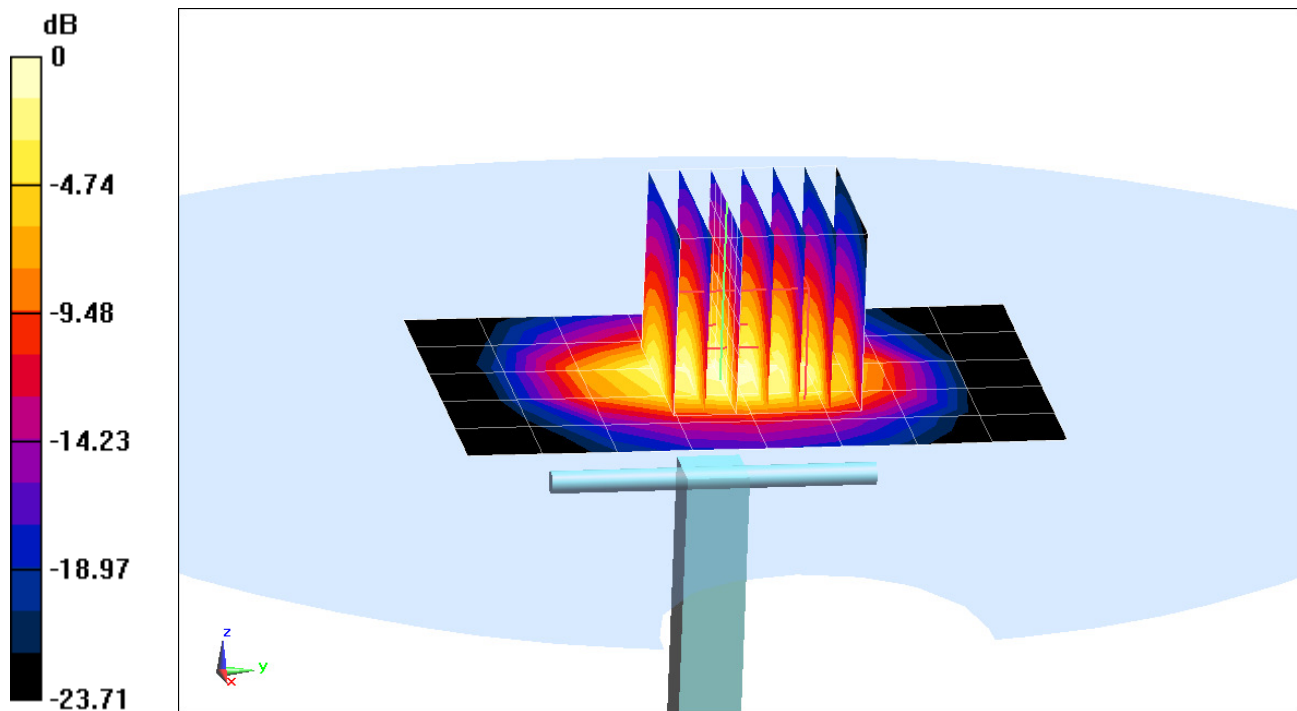

0 dB = 6.38 W/kg = 8.05 dBW/kg

APPENDIX C: PROBE CALIBRATION



Accredited by the Swiss Accreditation Service (SAS)
The Swiss Accreditation Service is one of the signatories to the EA
Multilateral Agreement for the recognition of calibration certificates

Accreditation No.: **SCS 108**

Client **PC Test**

Certificate No.: **ES3-3022_Aug13**

CALIBRATION CERTIFICATE

Object **ES3DV2 - SN:3022**

Calibration procedure(s) **QA CAL-01.v9, QA CAL-23.v5, QA CAL-25.v6
Calibration procedure for dosimetric E-field probes**

Calibration date: **August 22, 2013**

UTC
9/13/13

This calibration certificate documents the traceability to national standards, which realize the physical units of measurements (SI).
The measurements and the uncertainties with confidence probability are given on the following pages and are part of the certificate.

All calibrations have been conducted in the closed laboratory facility: environment temperature (22 ± 3)°C and humidity < 70%.

Calibration Equipment used (M&TE critical for calibration)

| Primary Standards | ID | Cal Date (Certificate No.) | Scheduled Calibration |
|----------------------------|-----------------|-----------------------------------|------------------------|
| Power meter E4419B | GB41293874 | 04-Apr-13 (No. 217-01733) | Apr-14 |
| Power sensor E4412A | MY41498087 | 04-Apr-13 (No. 217-01733) | Apr-14 |
| Reference 3 dB Attenuator | SN: S5054 (3c) | 04-Apr-13 (No. 217-01737) | Apr-14 |
| Reference 20 dB Attenuator | SN: S5277 (20x) | 04-Apr-13 (No. 217-01735) | Apr-14 |
| Reference 30 dB Attenuator | SN: S5129 (30b) | 04-Apr-13 (No. 217-01738) | Apr-14 |
| Reference Probe ES3DV2 | SN: 3013 | 28-Dec-12 (No. ES3-3013_Dec12) | Dec-13 |
| DAE4 | SN: 660 | 31-Jan-13 (No. DAE4-660_Jan13) | Jan-14 |
| Secondary Standards | ID | Check Date (in house) | Scheduled Check |
| RF generator HP 8648C | US3642U01700 | 4-Aug-99 (in house check Apr-13) | In house check: Apr-15 |
| Network Analyzer HP 8753E | US37390585 | 18-Oct-01 (in house check Oct-12) | In house check: Oct-13 |

| | Name | Function | Signature |
|----------------|----------------|-----------------------|-----------|
| Calibrated by: | Jeton Kastrati | Laboratory Technician | |
| Approved by: | Katja Pokovic | Technical Manager | |

Issued: August 23, 2013

This calibration certificate shall not be reproduced except in full without written approval of the laboratory.



Accredited by the Swiss Accreditation Service (SAS)

Accreditation No.: **SCS 108**

The Swiss Accreditation Service is one of the signatories to the EA
Multilateral Agreement for the recognition of calibration certificates

Glossary:

| | |
|--------------------------|---|
| TSL | tissue simulating liquid |
| NORM _{x,y,z} | sensitivity in free space |
| ConvF | sensitivity in TSL / NORM _{x,y,z} |
| DCP | diode compression point |
| CF | crest factor (1/duty_cycle) of the RF signal |
| A, B, C, D | modulation dependent linearization parameters |
| Polarization φ | φ rotation around probe axis |
| Polarization ϑ | ϑ rotation around an axis that is in the plane normal to probe axis (at measurement center), i.e., $\vartheta = 0$ is normal to probe axis |

Calibration is Performed According to the Following Standards:

- IEEE Std 1528-2003, "IEEE Recommended Practice for Determining the Peak Spatial-Averaged Specific Absorption Rate (SAR) in the Human Head from Wireless Communications Devices: Measurement Techniques", December 2003
- IEC 62209-1, "Procedure to measure the Specific Absorption Rate (SAR) for hand-held devices used in close proximity to the ear (frequency range of 300 MHz to 3 GHz)", February 2005

Methods Applied and Interpretation of Parameters:

- NORM_{x,y,z}**: Assessed for E-field polarization $\vartheta = 0$ ($f \leq 900$ MHz in TEM-cell; $f > 1800$ MHz: R22 waveguide). NORM_{x,y,z} are only intermediate values, i.e., the uncertainties of NORM_{x,y,z} does not affect the E²-field uncertainty inside TSL (see below ConvF).
- NORM(f)_{x,y,z}** = NORM_{x,y,z} * frequency_response (see Frequency Response Chart). This linearization is implemented in DASY4 software versions later than 4.2. The uncertainty of the frequency response is included in the stated uncertainty of ConvF.
- DCP_{x,y,z}**: DCP are numerical linearization parameters assessed based on the data of power sweep with CW signal (no uncertainty required). DCP does not depend on frequency nor media.
- PAR**: PAR is the Peak to Average Ratio that is not calibrated but determined based on the signal characteristics
- A_{x,y,z}; B_{x,y,z}; C_{x,y,z}; D_{x,y,z}; VR_{x,y,z}**: A, B, C, D are numerical linearization parameters assessed based on the data of power sweep for specific modulation signal. The parameters do not depend on frequency nor media. VR is the maximum calibration range expressed in RMS voltage across the diode.
- ConvF and Boundary Effect Parameters**: Assessed in flat phantom using E-field (or Temperature Transfer Standard for $f \leq 800$ MHz) and inside waveguide using analytical field distributions based on power measurements for $f > 800$ MHz. The same setups are used for assessment of the parameters applied for boundary compensation (alpha, depth) of which typical uncertainty values are given. These parameters are used in DASY4 software to improve probe accuracy close to the boundary. The sensitivity in TSL corresponds to NORM_{x,y,z} * ConvF whereby the uncertainty corresponds to that given for ConvF. A frequency dependent ConvF is used in DASY version 4.4 and higher which allows extending the validity from ± 50 MHz to ± 100 MHz.
- Spherical isotropy (3D deviation from isotropy)**: in a field of low gradients realized using a flat phantom exposed by a patch antenna.
- Sensor Offset**: The sensor offset corresponds to the offset of virtual measurement center from the probe tip (on probe axis). No tolerance required.

Probe ES3DV2

SN:3022

Manufactured: April 15, 2003
Calibrated: August 22, 2013

Calibrated for DASY/EASY Systems
(Note: non-compatible with DASY2 system!)

DASY/EASY - Parameters of Probe: ES3DV2 - SN:3022

Basic Calibration Parameters

| | Sensor X | Sensor Y | Sensor Z | Unc (k=2) |
|---|----------|----------|----------|-----------|
| Norm ($\mu\text{V}/(\text{V}/\text{m})^2$) ^A | 1.00 | 1.04 | 0.99 | ± 10.1 % |
| DCP (mV) ^B | 100.7 | 97.4 | 99.7 | |

Modulation Calibration Parameters

| UID | Communication System Name | | A dB | B dB/μV | C | D dB | VR mV | Unc ^E (k=2) |
|-----|---------------------------|---|---------|------------|-----|---------|----------|---------------------------|
| 0 | CW | X | 0.0 | 0.0 | 1.0 | 0.00 | 178.6 | ±3.0 % |
| | | Y | 0.0 | 0.0 | 1.0 | | 141.9 | |
| | | Z | 0.0 | 0.0 | 1.0 | | 134.7 | |

The reported uncertainty of measurement is stated as the standard uncertainty of measurement multiplied by the coverage factor k=2, which for a normal distribution corresponds to a coverage probability of approximately 95%.

^A The uncertainties of NormX,Y,Z do not affect the E²-field uncertainty inside TSL (see Pages 5 and 6).

^B Numerical linearization parameter: uncertainty not required.

^E Uncertainty is determined using the max. deviation from linear response applying rectangular distribution and is expressed for the square of the field value.

DASY/EASY - Parameters of Probe: ES3DV2 - SN:3022

Calibration Parameter Determined in Head Tissue Simulating Media

| f (MHz) ^C | Relative Permittivity ^F | Conductivity (S/m) ^F | ConvF X | ConvF Y | ConvF Z | Alpha | Depth (mm) | Unct. (k=2) |
|----------------------|------------------------------------|---------------------------------|---------|---------|---------|-------|------------|-------------|
| 750 | 41.9 | 0.89 | 6.21 | 6.21 | 6.21 | 0.19 | 2.37 | ± 12.0 % |
| 835 | 41.5 | 0.90 | 6.09 | 6.09 | 6.09 | 0.30 | 1.70 | ± 12.0 % |
| 1750 | 40.1 | 1.37 | 5.19 | 5.19 | 5.19 | 0.65 | 1.23 | ± 12.0 % |
| 1900 | 40.0 | 1.40 | 5.03 | 5.03 | 5.03 | 0.51 | 1.43 | ± 12.0 % |
| 2450 | 39.2 | 1.80 | 4.36 | 4.36 | 4.36 | 0.51 | 1.51 | ± 12.0 % |
| 2600 | 39.0 | 1.96 | 4.16 | 4.16 | 4.16 | 0.74 | 1.29 | ± 12.0 % |

^C Frequency validity of ± 100 MHz only applies for DASY v4.4 and higher (see Page 2), else it is restricted to ± 50 MHz. The uncertainty is the RSS of the ConvF uncertainty at calibration frequency and the uncertainty for the indicated frequency band.

^F At frequencies below 3 GHz, the validity of tissue parameters (ϵ and σ) can be relaxed to ± 10% if liquid compensation formula is applied to measured SAR values. At frequencies above 3 GHz, the validity of tissue parameters (ϵ and σ) is restricted to ± 5%. The uncertainty is the RSS of the ConvF uncertainty for indicated target tissue parameters.

DASY/EASY - Parameters of Probe: ES3DV2 - SN:3022

Calibration Parameter Determined in Body Tissue Simulating Media

| f (MHz) ^C | Relative Permittivity ^F | Conductivity (S/m) ^F | ConvF X | ConvF Y | ConvF Z | Alpha | Depth (mm) | Unct. (k=2) |
|----------------------|------------------------------------|---------------------------------|---------|---------|---------|-------|------------|-------------|
| 750 | 55.5 | 0.96 | 5.92 | 5.92 | 5.92 | 0.24 | 1.99 | ± 12.0 % |
| 835 | 55.2 | 0.97 | 5.91 | 5.91 | 5.91 | 0.29 | 1.85 | ± 12.0 % |
| 1750 | 53.4 | 1.49 | 4.75 | 4.75 | 4.75 | 0.52 | 1.52 | ± 12.0 % |
| 1900 | 53.3 | 1.52 | 4.49 | 4.49 | 4.49 | 0.49 | 1.56 | ± 12.0 % |
| 2450 | 52.7 | 1.95 | 4.01 | 4.01 | 4.01 | 0.70 | 1.02 | ± 12.0 % |
| 2600 | 52.5 | 2.16 | 3.85 | 3.85 | 3.85 | 0.58 | 0.90 | ± 12.0 % |

^C Frequency validity of ± 100 MHz only applies for DASY v4.4 and higher (see Page 2), else it is restricted to ± 50 MHz. The uncertainty is the RSS of the ConvF uncertainty at calibration frequency and the uncertainty for the indicated frequency band.

^F At frequencies below 3 GHz, the validity of tissue parameters (ϵ and σ) can be relaxed to ± 10% if liquid compensation formula is applied to measured SAR values. At frequencies above 3 GHz, the validity of tissue parameters (ϵ and σ) is restricted to ± 5%. The uncertainty is the RSS of the ConvF uncertainty for indicated target tissue parameters.

Frequency Response of E-Field (TEM-Cell:ifi110 EXX, Waveguide: R22)

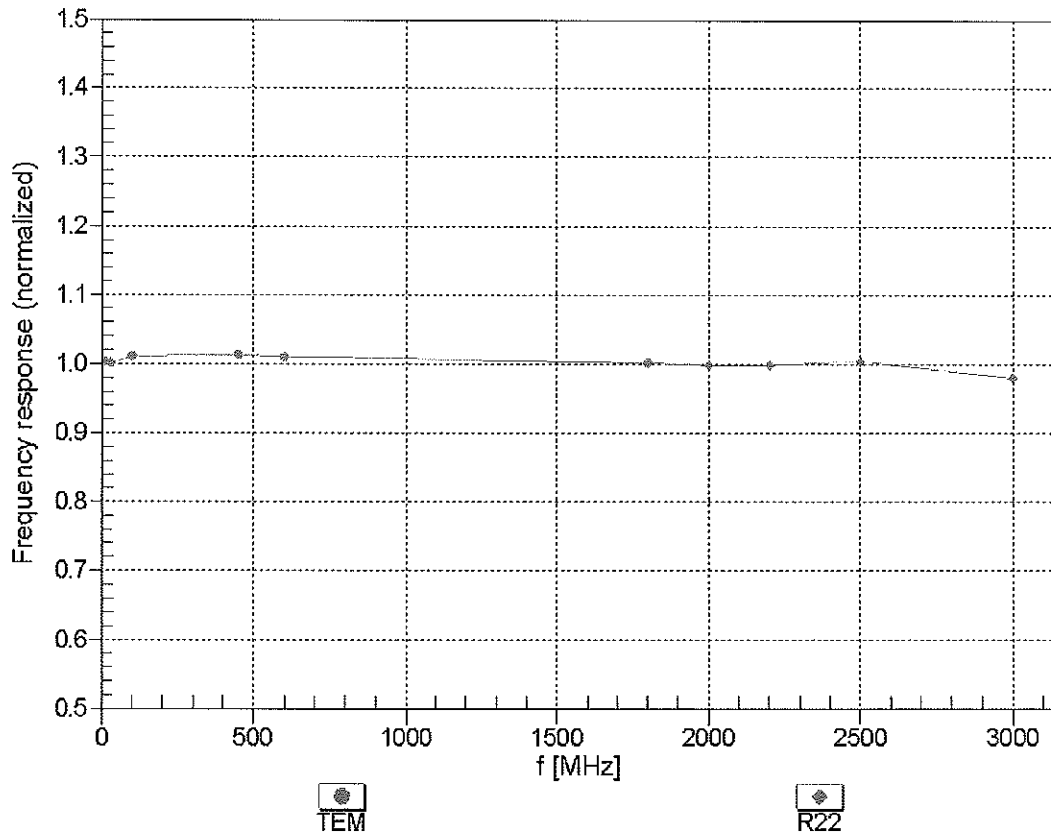

Uncertainty of Frequency Response of E-field: $\pm 6.3\%$ (k=2)

Receiving Pattern (ϕ), $\theta = 0^\circ$

f=600 MHz,TEM

f=1800 MHz,R22

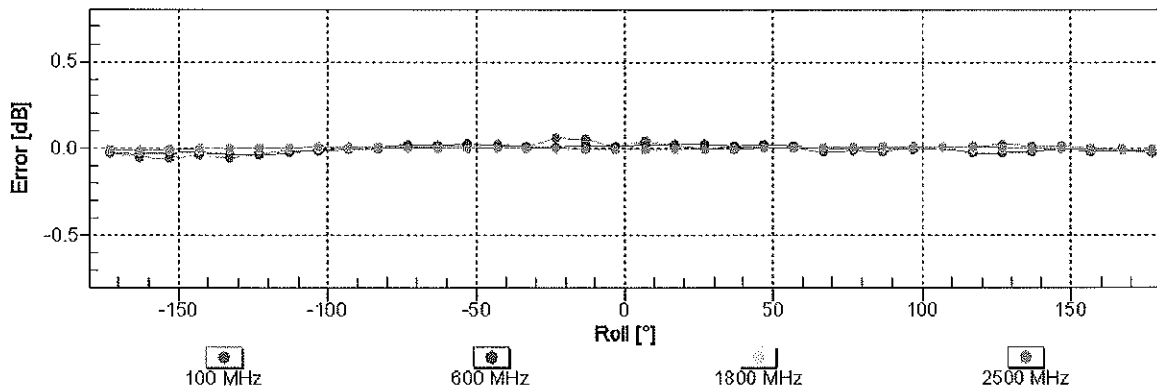
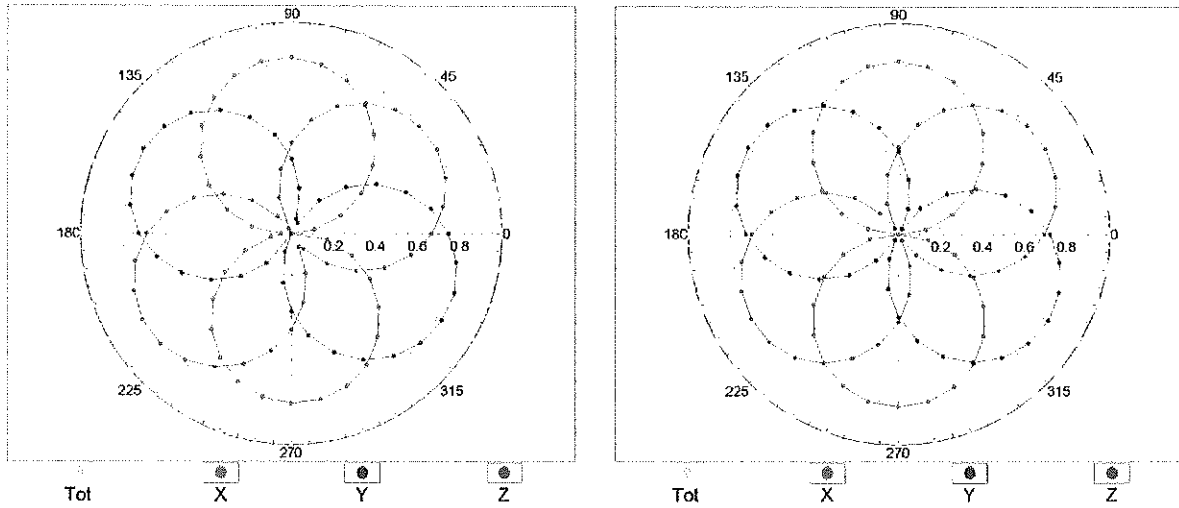

Uncertainty of Axial Isotropy Assessment: $\pm 0.5\%$ ($k=2$)

Dynamic Range f(SAR_{head}) (TEM cell , f = 900 MHz)

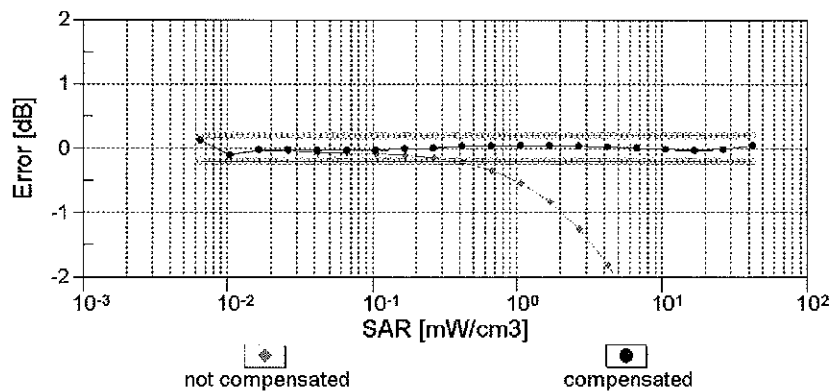
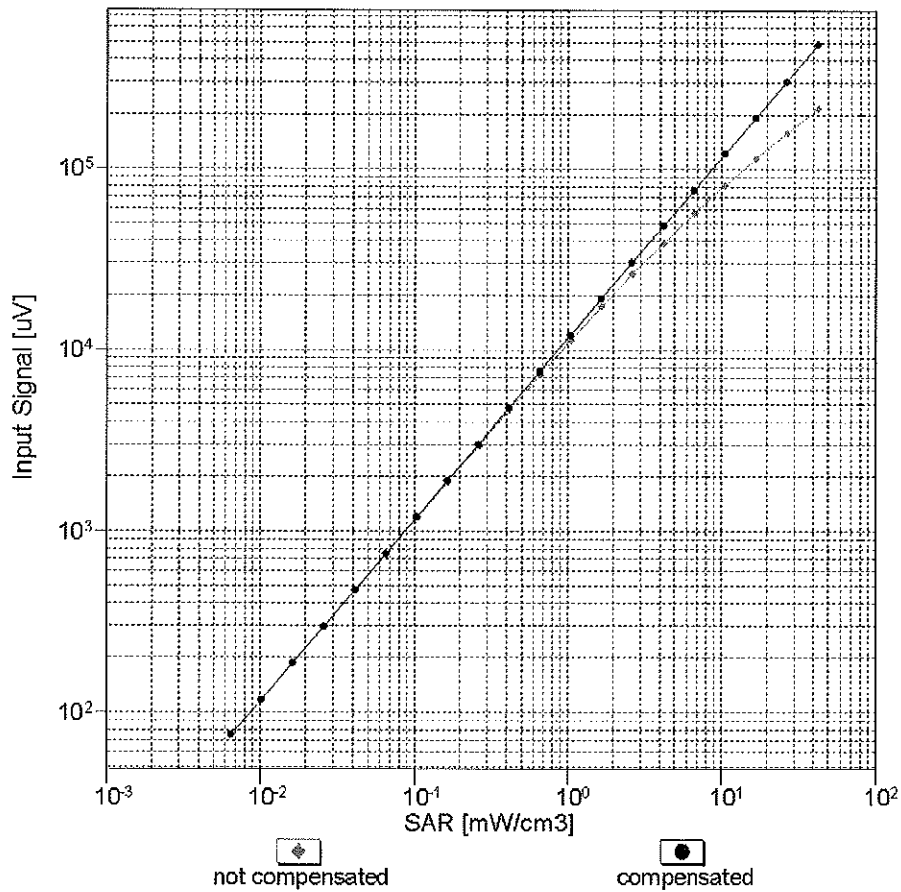

Uncertainty of Linearity Assessment: ± 0.6% (k=2)

Conversion Factor Assessment

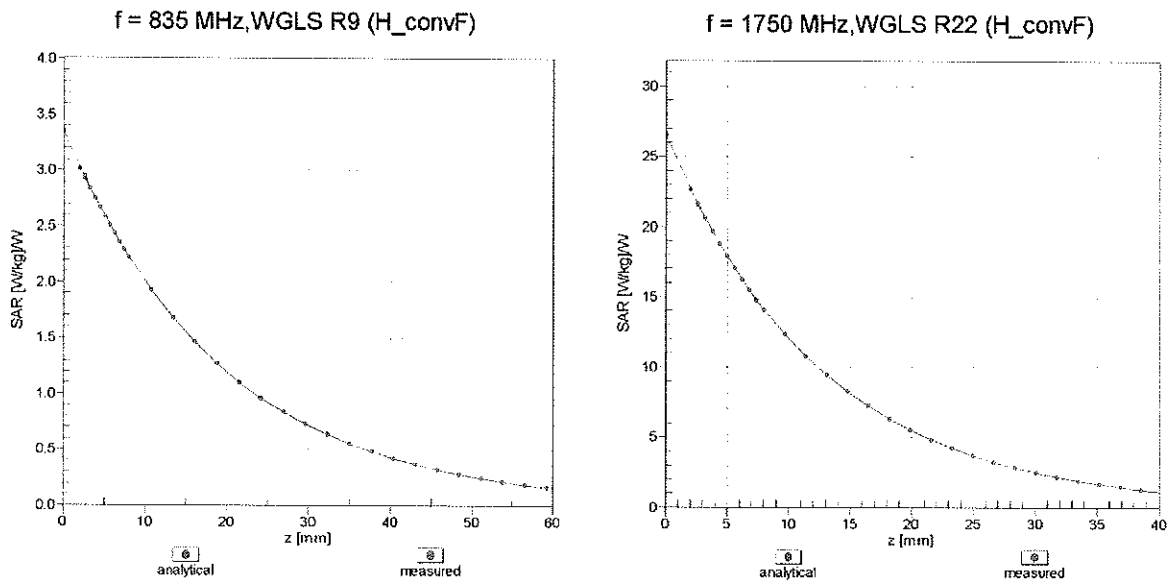

Deviation from Isotropy in Liquid Error (ϕ, θ), f = 900 MHz

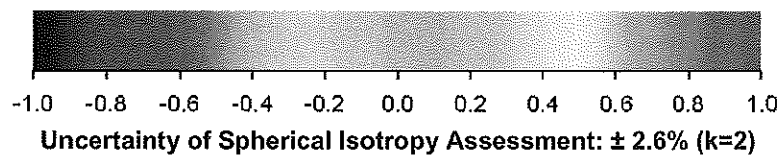
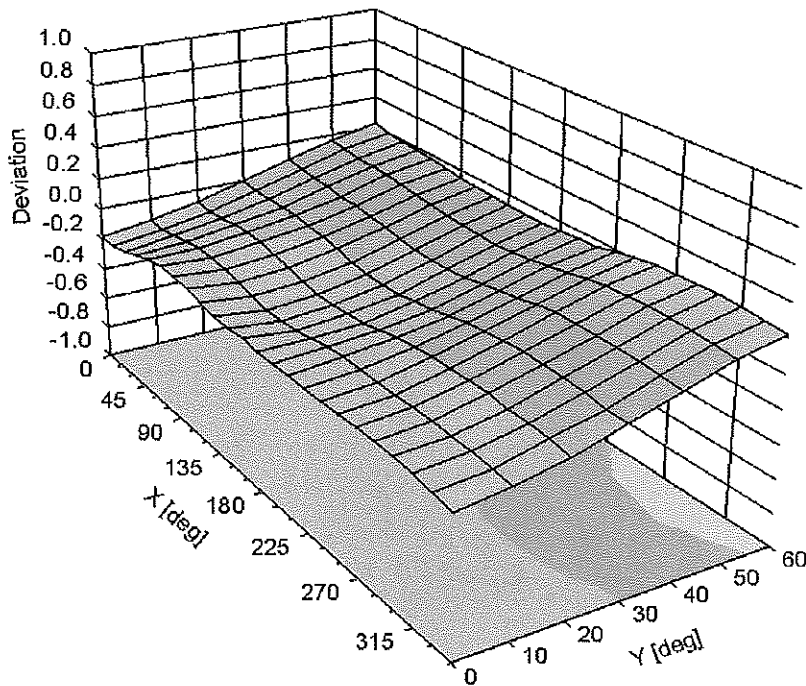

DASY/EASY - Parameters of Probe: ES3DV2 - SN:3022

Other Probe Parameters

| | |
|---|------------|
| Sensor Arrangement | Triangular |
| Connector Angle (°) | -83.1 |
| Mechanical Surface Detection Mode | enabled |
| Optical Surface Detection Mode | disabled |
| Probe Overall Length | 337 mm |
| Probe Body Diameter | 10 mm |
| Tip Length | 10 mm |
| Tip Diameter | 4 mm |
| Probe Tip to Sensor X Calibration Point | 2 mm |
| Probe Tip to Sensor Y Calibration Point | 2 mm |
| Probe Tip to Sensor Z Calibration Point | 2 mm |
| Recommended Measurement Distance from Surface | 3 mm |



Accredited by the Swiss Accreditation Service (SAS)
The Swiss Accreditation Service is one of the signatories to the EA
Multilateral Agreement for the recognition of calibration certificates

Accreditation No.: **SCS 108**

Client **PC Test**

Certificate No: **ES3-3209_Mar13**

CALIBRATION CERTIFICATE

Object **ES3DV3 - SN:3209**

Calibration procedure(s) **QA CAL-01.v8, QA CAL-23.v4, QA CAL-25.v4
Calibration procedure for dosimetric E-field probes**

Calibration date: **March 15, 2013**

This calibration certificate documents the traceability to national standards, which realize the physical units of measurements (SI).
The measurements and the uncertainties with confidence probability are given on the following pages and are part of the certificate.

All calibrations have been conducted in the closed laboratory facility: environment temperature (22 ± 3)°C and humidity < 70%.

*✓ KOK
3/22/13*

Calibration Equipment used (M&TE critical for calibration)

| Primary Standards | ID | Cal Date (Certificate No.) | Scheduled Calibration |
|----------------------------|-----------------|-----------------------------------|------------------------|
| Power meter E4419B | GB41293874 | 29-Mar-12 (No. 217-01508) | Apr-13 |
| Power sensor E4412A | MY41498087 | 29-Mar-12 (No. 217-01508) | Apr-13 |
| Reference 3 dB Attenuator | SN: S5054 (3c) | 27-Mar-12 (No. 217-01531) | Apr-13 |
| Reference 20 dB Attenuator | SN: S5086 (20b) | 27-Mar-12 (No. 217-01529) | Apr-13 |
| Reference 30 dB Attenuator | SN: S5129 (30b) | 27-Mar-12 (No. 217-01532) | Apr-13 |
| Reference Probe ES3DV2 | SN: 3013 | 28-Dec-12 (No. ES3-3013_Dec12) | Dec-13 |
| DAE4 | SN: 660 | 31-Jan-13 (No. DAE4-660_Jan13) | Jan-14 |
| Secondary Standards | ID | Check Date (in house) | Scheduled Check |
| RF generator HP 8648C | US3642U01700 | 4-Aug-99 (in house check Apr-11) | In house check: Apr-13 |
| Network Analyzer HP 8753E | US37390585 | 18-Oct-01 (in house check Oct-12) | In house check: Oct-13 |

| | Name | Function | Signature |
|----------------|----------------|-----------------------|-----------------------|
| Calibrated by: | Israe El-Naouq | Laboratory Technician | <i>Israe El-Naouq</i> |
| Approved by: | Katja Pokovic | Technical Manager | <i>Katja Pokovic</i> |

Issued: March 15, 2013

This calibration certificate shall not be reproduced except in full without written approval of the laboratory.

80244



Accredited by the Swiss Accreditation Service (SAS)

Accreditation No.: **SCS 108**

The Swiss Accreditation Service is one of the signatories to the EA
 Multilateral Agreement for the recognition of calibration certificates

Glossary:

| | |
|-----------------------|---|
| TSL | tissue simulating liquid |
| NORM _{x,y,z} | sensitivity in free space |
| ConvF | sensitivity in TSL / NORM _{x,y,z} |
| DCP | diode compression point |
| CF | crest factor (1/duty_cycle) of the RF signal |
| A, B, C, D | modulation dependent linearization parameters |
| Polarization φ | φ rotation around probe axis |
| Polarization ϑ | ϑ rotation around an axis that is in the plane normal to probe axis (at measurement center), i.e., ϑ = 0 is normal to probe axis |

Calibration is Performed According to the Following Standards:

- a) IEEE Std 1528-2003, "IEEE Recommended Practice for Determining the Peak Spatial-Averaged Specific Absorption Rate (SAR) in the Human Head from Wireless Communications Devices: Measurement Techniques", December 2003
- b) IEC 62209-1, "Procedure to measure the Specific Absorption Rate (SAR) for hand-held devices used in close proximity to the ear (frequency range of 300 MHz to 3 GHz)", February 2005

Methods Applied and Interpretation of Parameters:

- *NORM_{x,y,z}*: Assessed for E-field polarization ϑ = 0 (f ≤ 900 MHz in TEM-cell; f > 1800 MHz: R22 waveguide). *NORM_{x,y,z}* are only intermediate values, i.e., the uncertainties of *NORM_{x,y,z}* does not affect the E²-field uncertainty inside TSL (see below *ConvF*).
- *NORM(f)_{x,y,z}* = *NORM_{x,y,z}* * *frequency_response* (see Frequency Response Chart). This linearization is implemented in DASY4 software versions later than 4.2. The uncertainty of the frequency response is included in the stated uncertainty of *ConvF*.
- *DCP_{x,y,z}*: DCP are numerical linearization parameters assessed based on the data of power sweep with CW signal (no uncertainty required). DCP does not depend on frequency nor media.
- *PAR*: *PAR* is the Peak to Average Ratio that is not calibrated but determined based on the signal characteristics
- *A_{x,y,z}*; *B_{x,y,z}*; *C_{x,y,z}*; *D_{x,y,z}*; *VR_{x,y,z}*; *A*, *B*, *C*, *D* are numerical linearization parameters assessed based on the data of power sweep for specific modulation signal. The parameters do not depend on frequency nor media. *VR* is the maximum calibration range expressed in RMS voltage across the diode.
- *ConvF* and *Boundary Effect Parameters*: Assessed in flat phantom using E-field (or Temperature Transfer Standard for f ≤ 800 MHz) and inside waveguide using analytical field distributions based on power measurements for f > 800 MHz. The same setups are used for assessment of the parameters applied for boundary compensation (alpha, depth) of which typical uncertainty values are given. These parameters are used in DASY4 software to improve probe accuracy close to the boundary. The sensitivity in TSL corresponds to *NORM_{x,y,z}* * *ConvF* whereby the uncertainty corresponds to that given for *ConvF*. A frequency dependent *ConvF* is used in DASY version 4.4 and higher which allows extending the validity from ± 50 MHz to ± 100 MHz.
- *Spherical isotropy (3D deviation from isotropy)*: in a field of low gradients realized using a flat phantom exposed by a patch antenna.
- *Sensor Offset*: The sensor offset corresponds to the offset of virtual measurement center from the probe tip (on probe axis). No tolerance required.

Probe ES3DV3

SN:3209

Manufactured: October 14, 2008
Calibrated: March 15, 2013

Calibrated for DASY/EASY Systems
(Note: non-compatible with DASY2 system!)

DASY/EASY - Parameters of Probe: ES3DV3 - SN:3209

Basic Calibration Parameters

| | Sensor X | Sensor Y | Sensor Z | Unc (k=2) |
|---|----------|----------|----------|---------------|
| Norm ($\mu\text{V}/(\text{V}/\text{m})^2$) ^A | 1.35 | 1.33 | 1.14 | $\pm 10.1 \%$ |
| DCP (mV) ^B | 99.2 | 97.8 | 98.3 | |

Modulation Calibration Parameters

| UID | Communication System Name | | A dB | B dB $\sqrt{\mu\text{V}}$ | C | D dB | VR mV | Unc ^E (k=2) |
|-----|---------------------------|---|---------|------------------------------|-----|---------|----------|---------------------------|
| 0 | CW | X | 0.0 | 0.0 | 1.0 | 0.00 | 163.6 | $\pm 3.5 \%$ |
| | | Y | 0.0 | 0.0 | 1.0 | | 170.3 | |
| | | Z | 0.0 | 0.0 | 1.0 | | 158.7 | |

The reported uncertainty of measurement is stated as the standard uncertainty of measurement multiplied by the coverage factor $k=2$, which for a normal distribution corresponds to a coverage probability of approximately 95%.

^A The uncertainties of NormX,Y,Z do not affect the E^2 -field uncertainty inside TSL (see Pages 5 and 6).

^B Numerical linearization parameter: uncertainty not required.

^E Uncertainty is determined using the max. deviation from linear response applying rectangular distribution and is expressed for the square of the field value.

DASY/EASY - Parameters of Probe: ES3DV3 - SN:3209

Calibration Parameter Determined in Head Tissue Simulating Media

| f (MHz) ^C | Relative Permittivity ^F | Conductivity (S/m) ^F | ConvF X | ConvF Y | ConvF Z | Alpha | Depth (mm) | Unct. (k=2) |
|----------------------|------------------------------------|---------------------------------|---------|---------|---------|-------|------------|-------------|
| 750 | 41.9 | 0.89 | 6.74 | 6.74 | 6.74 | 0.76 | 1.18 | ± 12.0 % |
| 835 | 41.5 | 0.90 | 6.46 | 6.46 | 6.46 | 0.31 | 1.81 | ± 12.0 % |
| 1750 | 40.1 | 1.37 | 5.39 | 5.39 | 5.39 | 0.80 | 1.21 | ± 12.0 % |
| 1900 | 40.0 | 1.40 | 5.21 | 5.21 | 5.21 | 0.78 | 1.26 | ± 12.0 % |
| 2450 | 39.2 | 1.80 | 4.57 | 4.57 | 4.57 | 0.65 | 1.43 | ± 12.0 % |
| 2600 | 39.0 | 1.96 | 4.43 | 4.43 | 4.43 | 0.75 | 1.36 | ± 12.0 % |

^C Frequency validity of ± 100 MHz only applies for DASY v4.4 and higher (see Page 2), else it is restricted to ± 50 MHz. The uncertainty is the RSS of the ConvF uncertainty at calibration frequency and the uncertainty for the indicated frequency band.

^F At frequencies below 3 GHz, the validity of tissue parameters (ϵ and σ) can be relaxed to ± 10% if liquid compensation formula is applied to measured SAR values. At frequencies above 3 GHz, the validity of tissue parameters (ϵ and σ) is restricted to ± 5%. The uncertainty is the RSS of the ConvF uncertainty for indicated target tissue parameters.

DASY/EASY - Parameters of Probe: ES3DV3 - SN:3209

Calibration Parameter Determined in Body Tissue Simulating Media

| f (MHz) ^C | Relative Permittivity ^F | Conductivity (S/m) ^F | ConvF X | ConvF Y | ConvF Z | Alpha | Depth (mm) | Unct. (k=2) |
|----------------------|------------------------------------|---------------------------------|---------|---------|---------|-------|------------|-------------|
| 750 | 55.5 | 0.96 | 6.38 | 6.38 | 6.38 | 0.80 | 1.16 | ± 12.0 % |
| 835 | 55.2 | 0.97 | 6.28 | 6.28 | 6.28 | 0.52 | 1.45 | ± 12.0 % |
| 1750 | 53.4 | 1.49 | 5.03 | 5.03 | 5.03 | 0.58 | 1.45 | ± 12.0 % |
| 1900 | 53.3 | 1.52 | 4.77 | 4.77 | 4.77 | 0.70 | 1.36 | ± 12.0 % |
| 2450 | 52.7 | 1.95 | 4.34 | 4.34 | 4.34 | 0.80 | 1.15 | ± 12.0 % |
| 2600 | 52.5 | 2.16 | 4.11 | 4.11 | 4.11 | 0.80 | 1.00 | ± 12.0 % |

^C Frequency validity of ± 100 MHz only applies for DASY v4.4 and higher (see Page 2), else it is restricted to ± 50 MHz. The uncertainty is the RSS of the ConvF uncertainty at calibration frequency and the uncertainty for the indicated frequency band.

^F At frequencies below 3 GHz, the validity of tissue parameters (ϵ and σ) can be relaxed to ± 10% if liquid compensation formula is applied to measured SAR values. At frequencies above 3 GHz, the validity of tissue parameters (ϵ and σ) is restricted to ± 5%. The uncertainty is the RSS of the ConvF uncertainty for indicated target tissue parameters.

Frequency Response of E-Field (TEM-Cell:ifi110 EXX, Waveguide: R22)

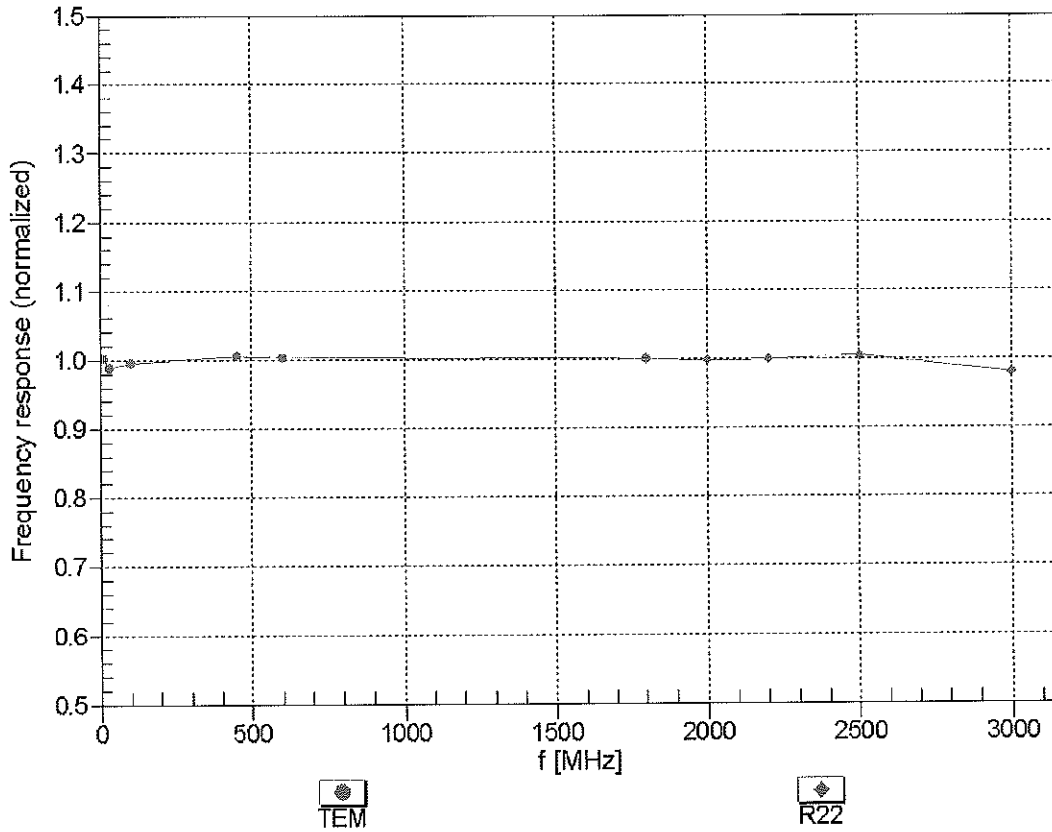

Uncertainty of Frequency Response of E-field: $\pm 6.3\%$ (k=2)

Receiving Pattern (ϕ), $\theta = 0^\circ$

f=600 MHz,TEM

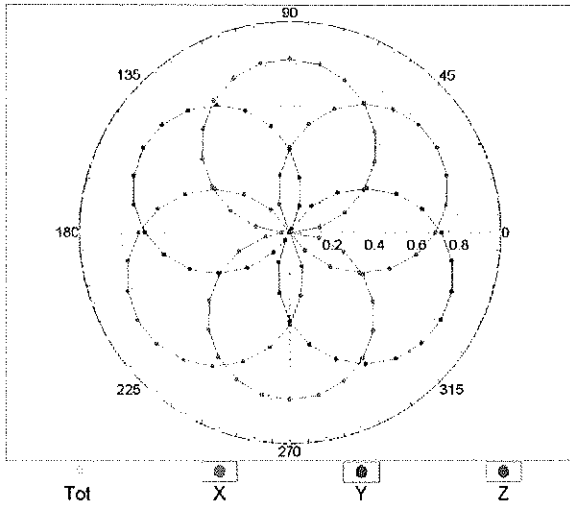

f=1800 MHz,R22

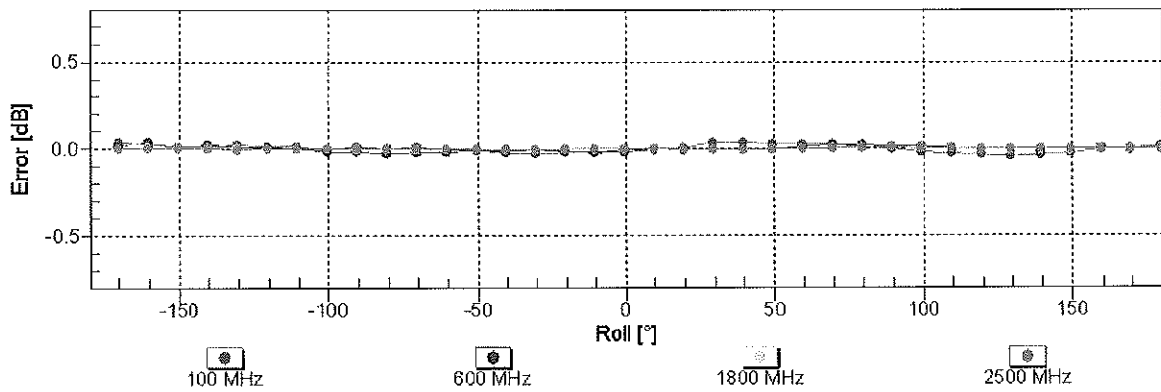
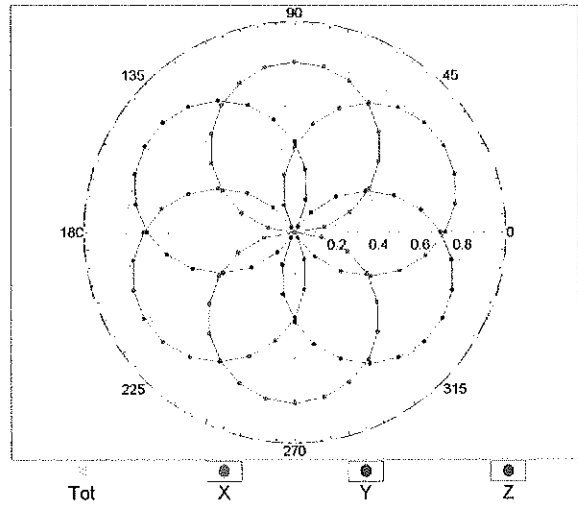

Uncertainty of Axial Isotropy Assessment: $\pm 0.5\%$ (k=2)

Dynamic Range $f(SAR_{head})$ (TEM cell , $f = 900$ MHz)

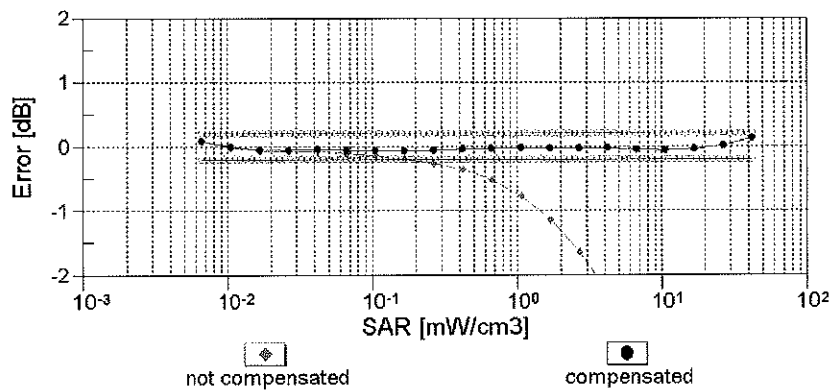
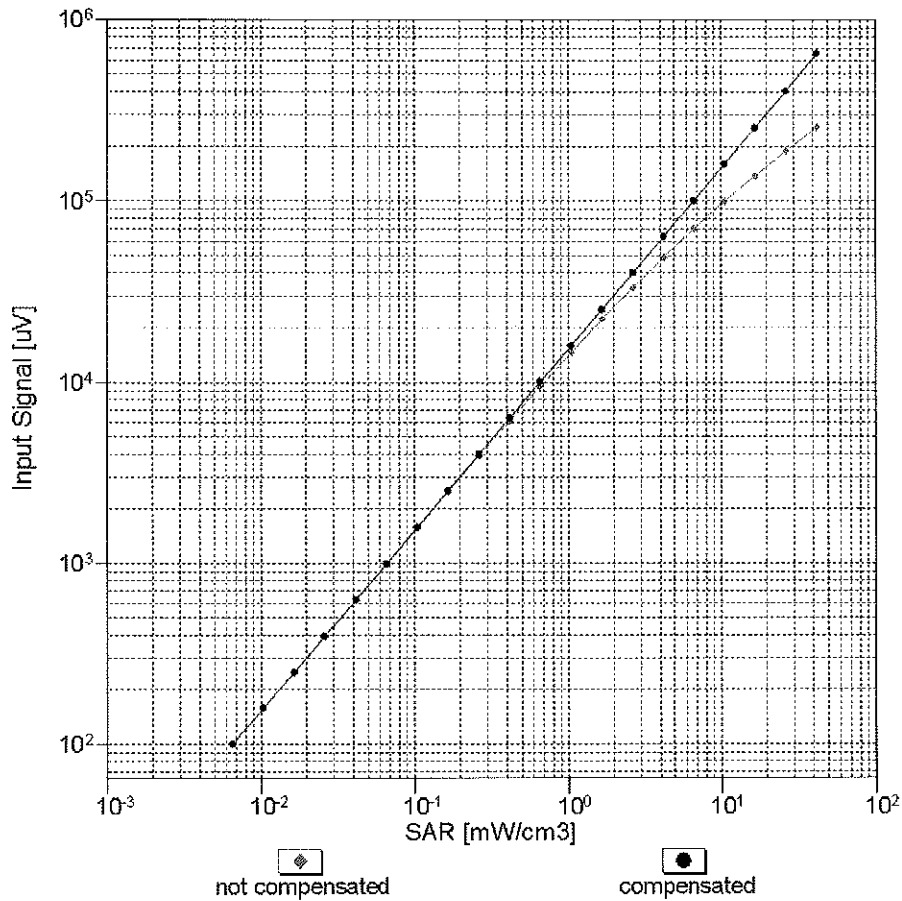

Uncertainty of Linearity Assessment: $\pm 0.6\%$ ($k=2$)

Conversion Factor Assessment

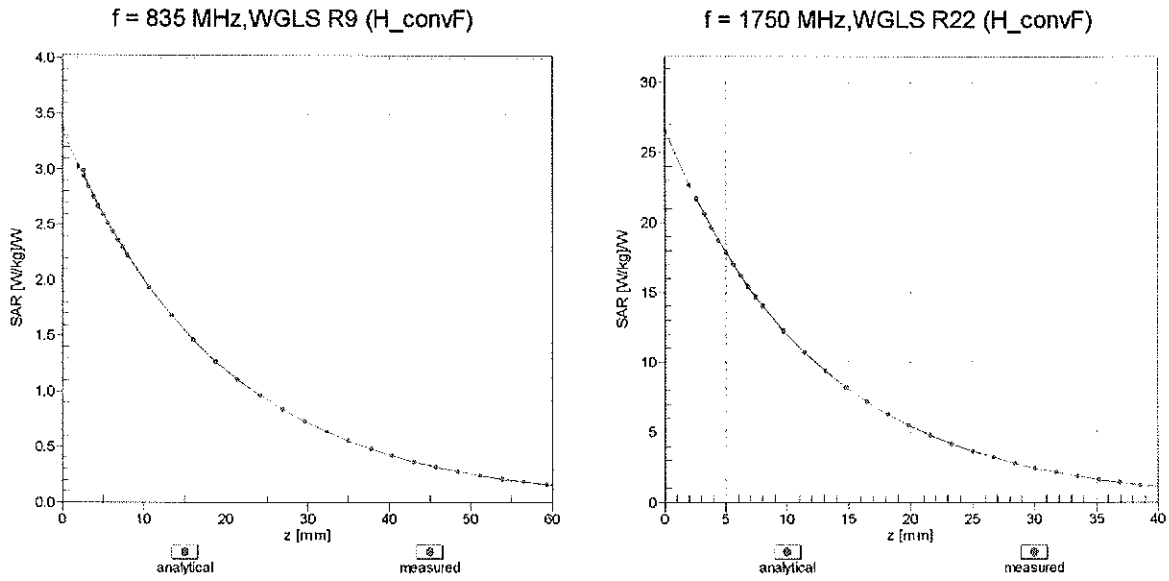

Deviation from Isotropy in Liquid Error (ϕ, θ), f = 900 MHz

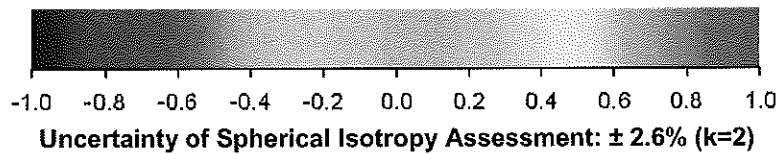
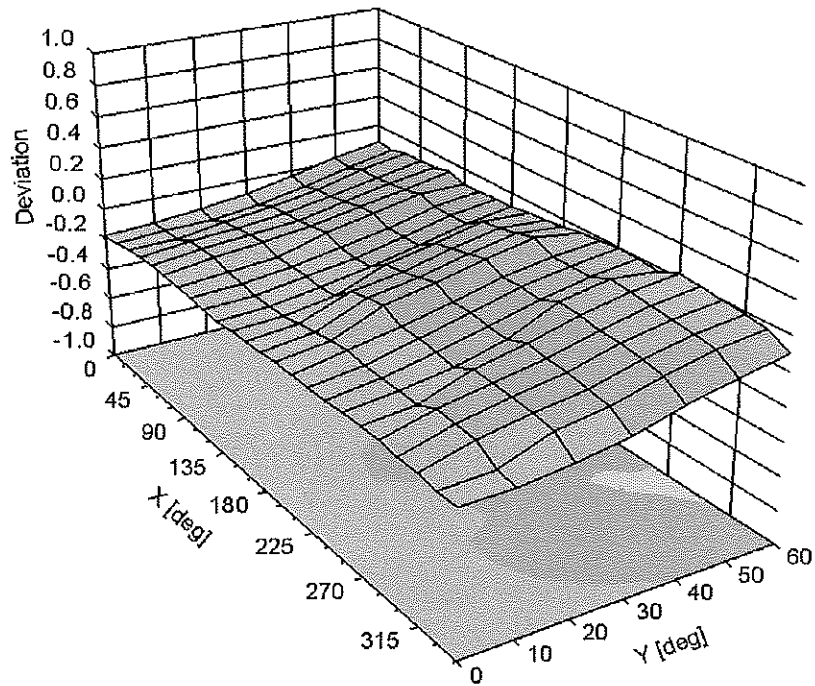

DASY/EASY - Parameters of Probe: ES3DV3 - SN:3209

Other Probe Parameters

| | |
|---|------------|
| Sensor Arrangement | Triangular |
| Connector Angle (°) | -40.6 |
| Mechanical Surface Detection Mode | enabled |
| Optical Surface Detection Mode | disabled |
| Probe Overall Length | 337 mm |
| Probe Body Diameter | 10 mm |
| Tip Length | 10 mm |
| Tip Diameter | 4 mm |
| Probe Tip to Sensor X Calibration Point | 2 mm |
| Probe Tip to Sensor Y Calibration Point | 2 mm |
| Probe Tip to Sensor Z Calibration Point | 2 mm |
| Recommended Measurement Distance from Surface | 3 mm |