



**FCC CFR47 PART 15 SUBPART C
INDUSTRY CANADA RSS-210 ISSUE 8**

CERTIFICATION TEST REPORT

FOR

**GT-S6310B~802.11 b/g/n 1x1 HT20, + BT3.0+EDR+ GSM850/1900 & WCDMA850MHz
Bar phone
EUT**

MODEL NUMBER: GT-S6310B

FCC ID: A3LGTS6310B

REPORT NUMBER: 13I14974-1

ISSUE DATE: April 29, 2013

Prepared for
**SAMSUNG ELECTRONICS CO., LTD.
416, MAETAN 3-DONG, YEONGTONG-GU
SUWON-CITY
GYEONGGI-DO, 443-742, South Korea**

Prepared by
**UL CCS
47173 BENICIA STREET
FREMONT, CA 94538, U.S.A.
TEL: (510) 771-1000
FAX: (510) 661-0888**



NVLAP LAB CODE 200065-0

Revision History

<u>Rev.</u>	<u>Issue Date</u>	<u>Revisions</u>	<u>Revised By</u>
--		Initial Issue	

TABLE OF CONTENTS

1. ATTESTATION OF TEST RESULTS	5
2. TEST METHODOLOGY	6
3. FACILITIES AND ACCREDITATION	6
4. CALIBRATION AND UNCERTAINTY	6
4.1. MEASURING INSTRUMENT CALIBRATION	6
4.2. SAMPLE CALCULATION	6
4.3. MEASUREMENT UNCERTAINTY.....	6
5. EQUIPMENT UNDER TEST	7
5.1. DESCRIPTION OF EUT	7
5.2. MAXIMUM OUTPUT POWER.....	7
5.3. DESCRIPTION OF AVAILABLE ANTENNAS	7
5.4. SOFTWARE AND FIRMWARE.....	7
5.5. WORST-CASE CONFIGURATION AND MODE.....	7
5.6. DESCRIPTION OF TEST SETUP.....	8
6. TEST AND MEASUREMENT EQUIPMENT	11
7. ANTENNA PORT TEST RESULTS	12
7.1. BASIC DATA RATE GFSK MODULATION.....	12
7.1.1. 20 dB AND 99% BANDWIDTH	12
7.1.2. HOPPING FREQUENCY SEPARATION	15
7.2. HOPPING FREQUENCY SEPARATION	17
7.2.1. AVERAGE TIME OF OCCUPANCY	19
7.3. OUTPUT POWER.....	23
7.4. AVERAGE POWER.....	26
7.4.1. CONDUCTED SPURIOUS EMISSIONS.....	27
7.5. ENHANCED DATA RATE 8PSK MODULATION	32
7.5.1. 20 dB AND 99% BANDWIDTH	32
7.5.2. HOPPING FREQUENCY SEPARATION	35
7.5.3. NUMBER OF HOPPING CHANNELS.....	37
7.5.4. AVERAGE TIME OF OCCUPANCY	40
7.5.5. OUTPUT POWER	44
7.5.6. AVERAGE POWER.....	47
7.5.7. CONDUCTED SPURIOUS EMISSIONS.....	48
8. RADIATED TEST RESULTS.....	53
8.1. LIMITS AND PROCEDURE.....	53
8.2. TRANSMITTER ABOVE 1 GHz.....	54
8.2.1. BASIC DATA RATE GFSK MODULATION	54

8.2.2. ENHANCED DATA RATE 8PSK MODULATION	68
8.3. WORST-CASE BELOW 1 GHz.....	82
9. AC POWER LINE CONDUCTED EMISSIONS	85
10. SETUP PHOTOS.....	89

1. ATTESTATION OF TEST RESULTS

COMPANY NAME: SAMSUNG ELECTRONICS CO., LTD.
416, MAETAN 3-DONG, YEONGTONG-GU
SUWON-CITY, GYEONGGI-DO, 443-742, SOUTH KOREA

EUT DESCRIPTION: 802.11 b/g/n 1x1 HT20, + BT3.0+EDR+ GSM850/1900 &
WCDMA850MHz Bar phone

MODEL: GT-S6310B

SERIAL NUMBER: 356078050054143 (CONDUCTED);
96da715d (RADIATED)

DATE TESTED: APRIL 22-25, 2013

APPLICABLE STANDARDS	
STANDARD	TEST RESULTS
CFR 47 Part 15 Subpart C	Pass
INDUSTRY CANADA RSS-210 Issue 8 Annex 8	Pass
INDUSTRY CANADA RSS-GEN Issue 3	Pass

UL CCS tested the above equipment in accordance with the requirements set forth in the above standards. All indications of Pass/Fail in this report are opinions expressed by UL CCS based on interpretations and/or observations of test results. Measurement Uncertainties were not taken into account and are published for informational purposes only. The test results show that the equipment tested is capable of demonstrating compliance with the requirements as documented in this report.

Note: The results documented in this report apply only to the tested sample, under the conditions and modes of operation as described herein. This document may not be altered or revised in any way unless done so by UL CCS and all revisions are duly noted in the revisions section. Any alteration of this document not carried out by UL CCS will constitute fraud and shall nullify the document. This report must not be used by the client to claim product certification, approval, or endorsement by NVLAP, NIST, any agency of the Federal Government, or any agency of any government.

Approved & Released For UL CCS By:

Tested By:



PHILIP KIM
WiSE PROGRAM MANAGER
UL CCS

CHIN PANG
WiSE ENGINEER
UL CCS

2. TEST METHODOLOGY

The tests documented in this report were performed in accordance with ANSI C63.10-2009, FCC CFR 47 Part 2, FCC CFR 47 Part 15, RSS-GEN Issue 3, and RSS-210 Issue 8.

3. FACILITIES AND ACCREDITATION

The test sites and measurement facilities used to collect data are located at 47173 Benicia Street, Fremont, California, USA.

UL CCS is accredited by NVLAP, Laboratory Code 200065-0. The full scope of accreditation can be viewed at <http://www.ccsemc.com>.

4. CALIBRATION AND UNCERTAINTY

4.1. MEASURING INSTRUMENT CALIBRATION

The measuring equipment utilized to perform the tests documented in this report has been calibrated in accordance with the manufacturer's recommendations, and is traceable to recognized national standards.

4.2. SAMPLE CALCULATION

Where relevant, the following sample calculation is provided:

$$\begin{aligned} \text{Field Strength (dBuV/m)} &= \text{Measured Voltage (dBuV)} + \text{Antenna Factor (dB/m)} + \\ &\text{Cable Loss (dB)} - \text{Preamp Gain (dB)} \\ 36.5 \text{ dBuV} + 18.7 \text{ dB/m} + 0.6 \text{ dB} - 26.9 \text{ dB} &= 28.9 \text{ dBuV/m} \end{aligned}$$

4.3. MEASUREMENT UNCERTAINTY

Where relevant, the following measurement uncertainty levels have been estimated for tests performed on the apparatus:

PARAMETER	UNCERTAINTY
Conducted Disturbance, 0.15 to 30 MHz	3.52 dB
Radiated Disturbance, 30 to 1000 MHz	4.94 dB

Uncertainty figures are valid to a confidence level of 95%.

5. EQUIPMENT UNDER TEST

5.1. DESCRIPTION OF EUT

The EUT is a bar-style cell phone featuring 802.11b/g/n WLAN, Bluetooth, GPS and 2.4 GHz mobile hotspot, GSM850/1900 & WCDMA850MHz capability.

5.2. MAXIMUM OUTPUT POWER

The transmitter has a maximum peak conducted output power as follows:

Frequency Range (MHz)	Mode	Output Power (dBm)	Output Power (mW)
2402 - 2480	Basic GFSK	5.81	3.81
2402 - 2480	Enhanced 8PSK	5.89	3.88

5.3. DESCRIPTION OF AVAILABLE ANTENNAS

The radio utilizes an integrated PCB antenna, with a maximum gain of 1.44 dBi.

5.4. SOFTWARE AND FIRMWARE

The firmware installed in the EUT during testing was REVO.3

The EUT driver software installed during testing was S6310B.001.

5.5. WORST-CASE CONFIGURATION AND MODE

Radiated emission and power line conducted emission were performed with the EUT set to transmit at the channel with highest output power as worst-case scenario.

The fundamental of the EUT was investigated in three orthogonal orientations X, Y, Z and with AC Adapter and headset, it was determined that X orientation with AC Adapter was the worst-case orientation.

5.6. DESCRIPTION OF TEST SETUP

SUPPORT EQUIPMENT

Support Equipment List				
Description	Manufacturer	Model	Serial Number	FCC ID
AC Adapter	Samsung Electronics	ETA0U10JBE	DW2D104DS/7-E	N/A
Headset	Samsung Electronics	EHS61ASFWE	N/A	N/A

I/O CABLES (Conducted)

I/O CABLE LIST						
Cable No.	Port	# of Identical Ports	Connector Type	Cable Type	Cable Length	Remarks
1	In/Out	1	SMA	Shielded	None	NA
2	In/Out	1	SMA	Shielded	0.2m	NA
3	Antenna Port	1	SMA	Shielded	1.0m	To BT tester

I/O CABLES (RADIATED)

I/O CABLE LIST						
Cable No.	Port	# of Identical Ports	Connector Type	Cable Type	Cable Length	Remarks
1	DC	1	DC	Shielded	1m	NA
2	Audio	1	Earphone	Shielded	0.5m	NA

SETUP DIAGRAM FOR TESTS (CONDUCTED)

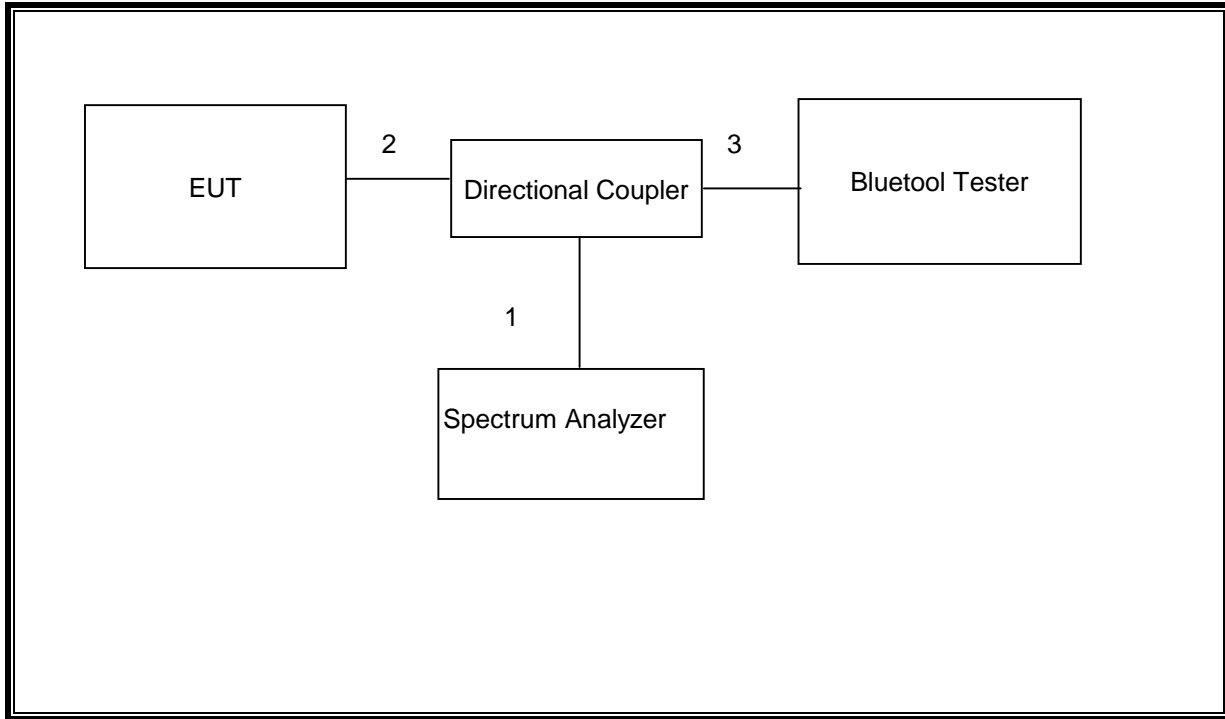

RADIATED SETUP S

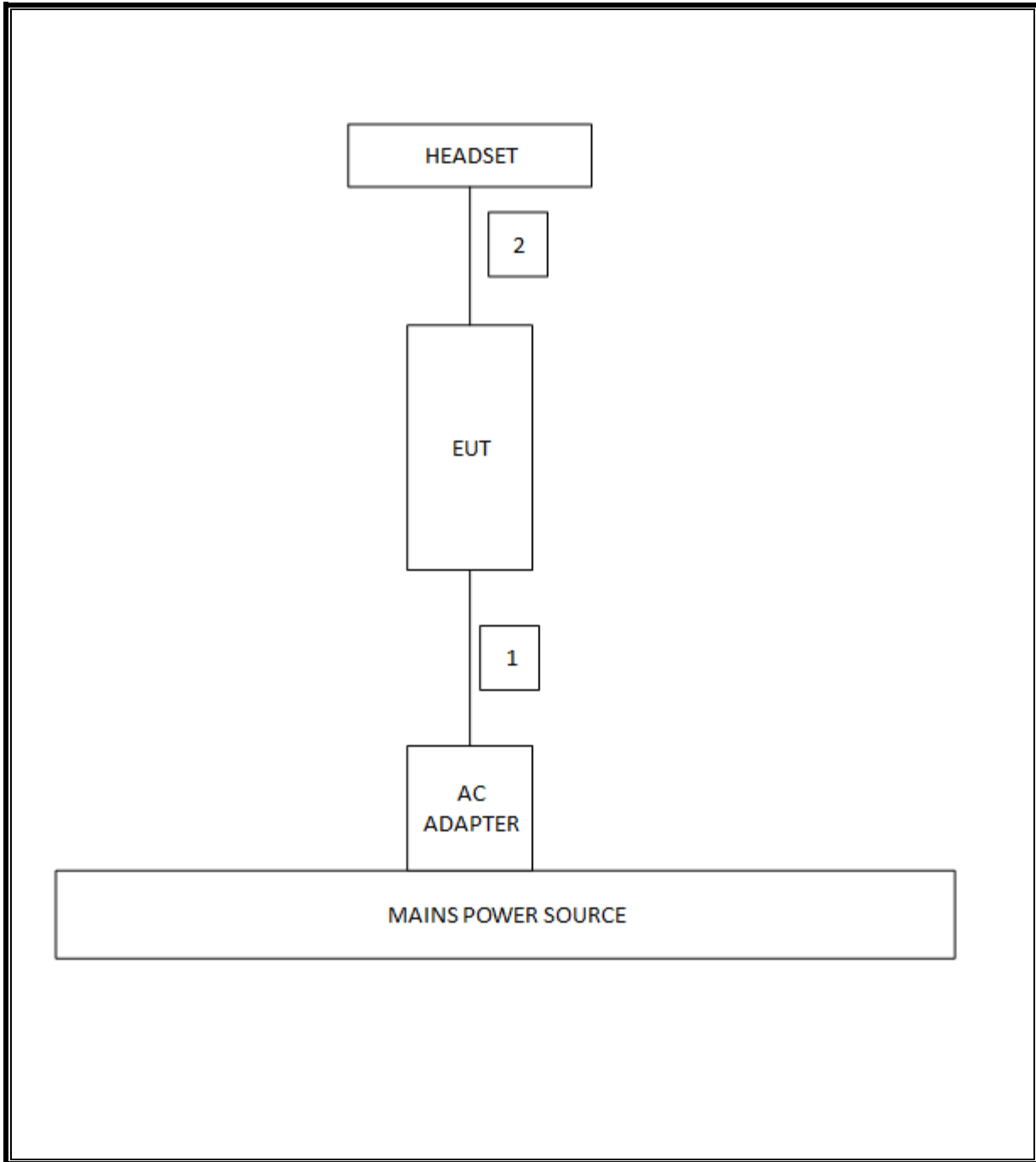

6. TEST AND MEASUREMENT EQUIPMENT

The following test and measurement equipment was utilized for the tests documented in this report:

Test Equipment List				
Description	Manufacturer	Model	Asset	Cal Due
Antenna, Horn, 18 GHz	EMCO	3115	C00872	09/20/13
Antenna, Horn, 26.5 GHz	ARA	MWH-1826/B	C00589	07/28/13
Spectrum Analyzer, 44 GHz	Agilent / HP	E4446A	C01012	10/21/13
Spectrum Analyzer, 26.5 GHz	Agilent	E4440A	N/A	03/19/14
CBT Bluetooth Tester	R & S	CBT	N/A	05/15/13
Preamplifier, 26.5 GHz	Agilent / HP	8449B	C00749	10/21/13
Preamplifier, 1300 MHz	Agilent / HP	8447D	C00558	02/21/14
Reject Filter, 2.4-2.5 GHz	Micro-Tronics	BRC13192	N02683	CNR
Bilog 30-2000MHz	Sunol	JB1	C01071	07/26/13
Power meter	HP	437B	T226	06/25/13
Power Sensor	HP	8481A	T233	06/26/13
LISN, 30 MHz	FCC	LISN-50/250-25-2	N02625	01/14/14
LISN, 10 kHz ~ 30 MHz	Solar	8012-50-R-24-BNC	N02481	03/07/14

7. ANTENNA PORT TEST RESULTS

7.1. BASIC DATA RATE GFSK MODULATION

7.1.1. 20 dB AND 99% BANDWIDTH

LIMIT

None; for reporting purposes only.

TEST PROCEDURE

The transmitter output is connected to a spectrum analyzer. The RBW is set to $\geq 1\%$ of the 20 dB bandwidth. The VBW is set to \geq RBW. The sweep time is coupled.

RESULTS

Channel	Frequency (MHz)	20 dB Bandwidth (kHz)	99% Bandwidth (kHz)
Low	2402	903.514	880.6755
Middle	2441	916.866	877.0930
High	2480	924.062	897.1296

20 dB AND 99% BANDWIDTH

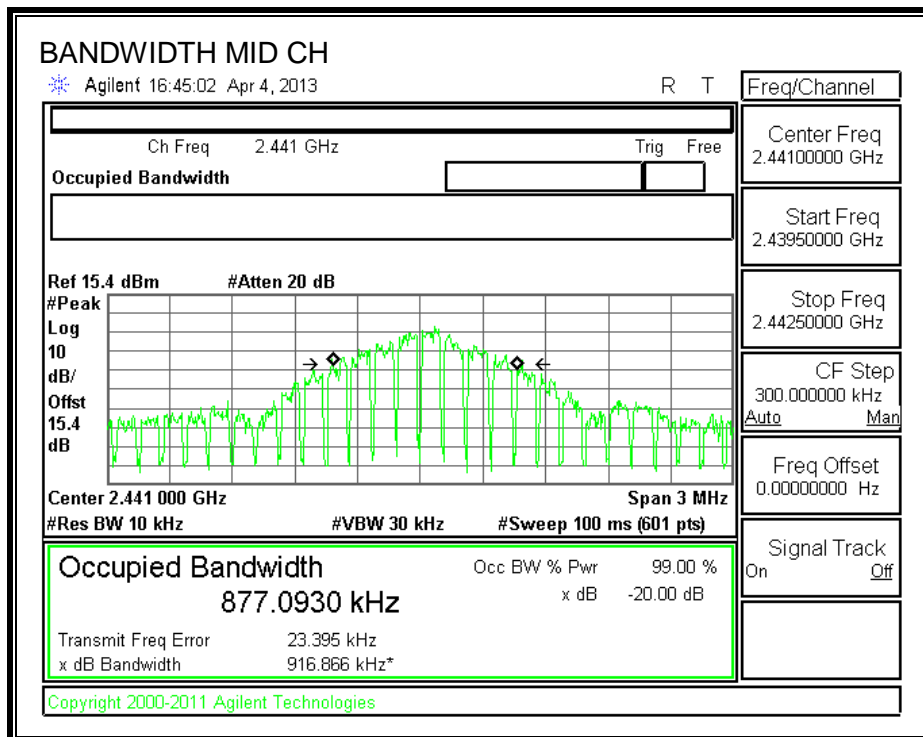
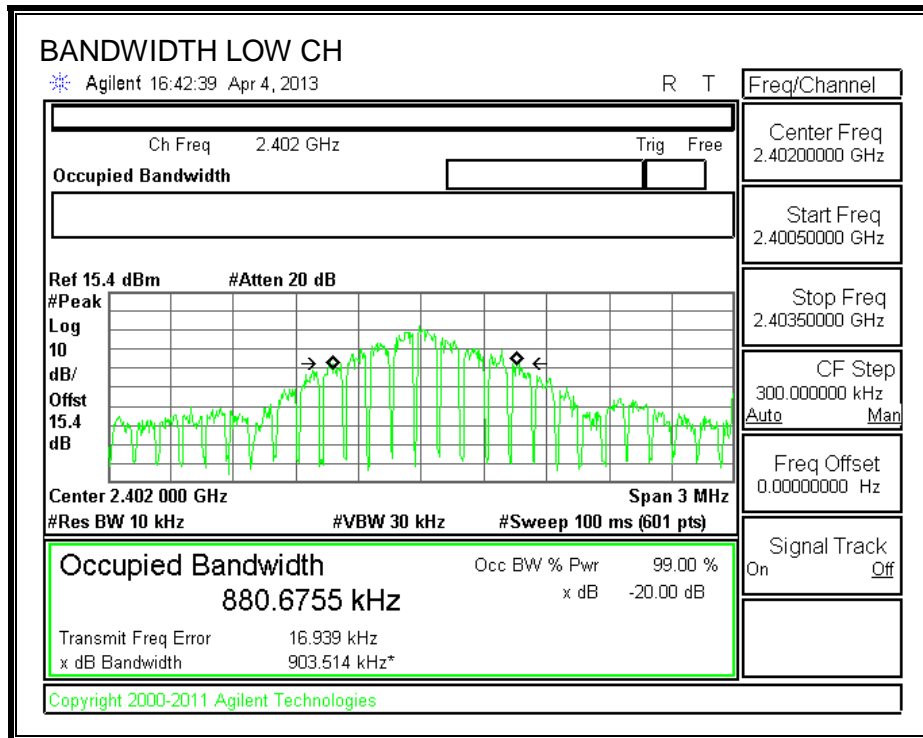

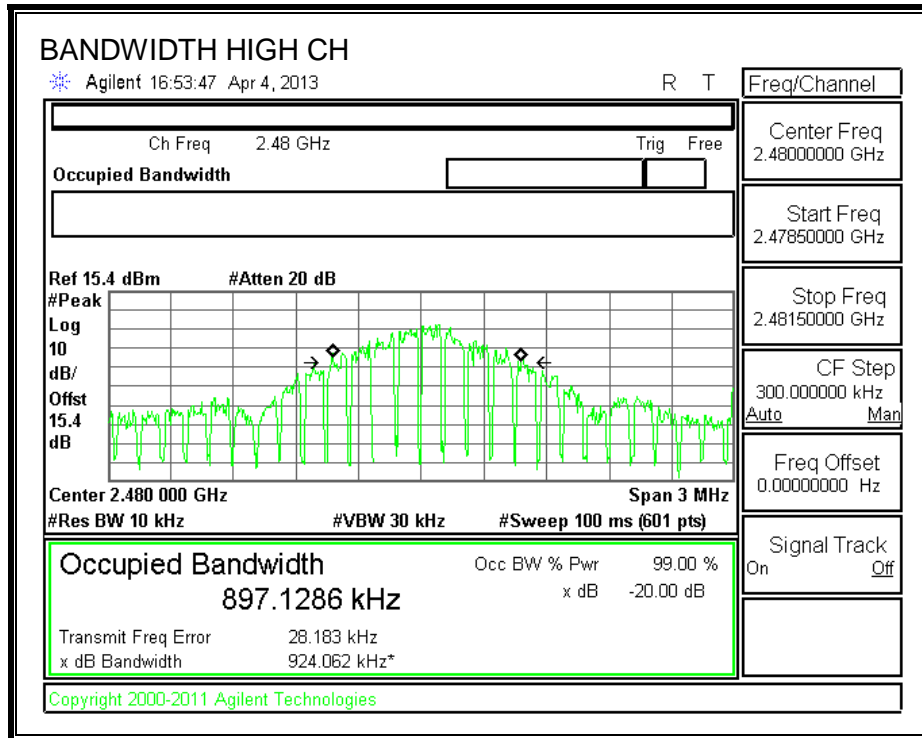

7.1.2. HOPPING FREQUENCY SEPARATION

LIMIT

FCC §15.247 (a) (1)

IC RSS-210 A8.1 (b)

Frequency hopping systems shall have hopping channel carrier frequencies separated by a minimum of 25 kHz or the 20 dB bandwidth of the hopping channel, whichever is greater.

Alternatively, frequency hopping systems operating in the 2400-2483.5 MHz band may have hopping channel carrier frequencies that are separated by 25 kHz or two-thirds of the 20 dB bandwidth of the hopping channel, whichever is greater, provided the systems operate with an output power no greater than 125 mW.

TEST PROCEDURE

The transmitter output is connected to a spectrum analyzer. The RBW is set to 100 kHz and the VBW is set to 100 kHz. The sweep time is coupled.

RESULTS

HOPPING FREQUENCY SEPARATION

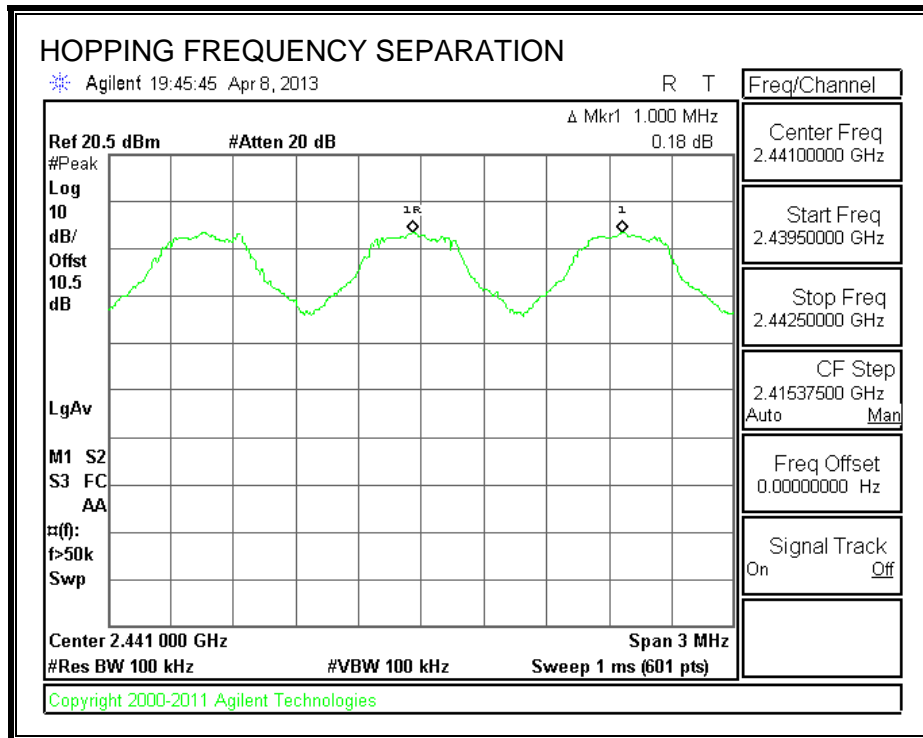

7.2. HOPPING FREQUENCY SEPARATION

LIMIT

FCC §15.247 (a) (1)

IC RSS-210 A8.1 (b)

Frequency hopping systems shall have hopping channel carrier frequencies separated by a minimum of 25 kHz or the 20 dB bandwidth of the hopping channel, whichever is greater.

Alternatively, frequency hopping systems operating in the 2400-2483.5 MHz band may have hopping channel carrier frequencies that are separated by 25 kHz or two-thirds of the 20 dB bandwidth of the hopping channel, whichever is greater, provided the systems operate with an output power no greater than 125 mW.

TEST PROCEDURE

The transmitter output is connected to a spectrum analyzer. The RBW is set to 100 kHz and the VBW is set to 100 kHz. The sweep time is coupled.

RESULTS

HOPPING FREQUENCY SEPARATION

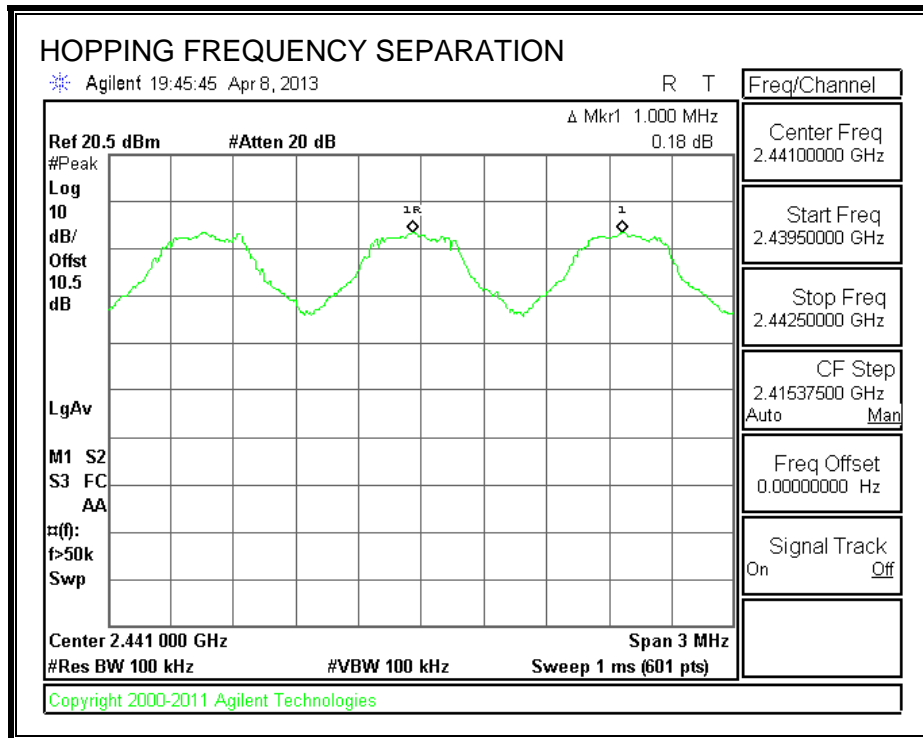

7.2.1. AVERAGE TIME OF OCCUPANCY

LIMIT

FCC §15.247 (a) (1) (iii)

IC RSS-210 A8.1 (d)

The average time of occupancy on any channel shall not be greater than 0.4 seconds within a period of 0.4 seconds multiplied by the number of hopping channels employed.

TEST PROCEDURE

The transmitter output is connected to a spectrum analyzer. The span is set to 0 Hz, centered on a single, selected hopping channel. The width of a single pulse is measured in a fast scan. The number of pulses is measured in a 3.16 second scan, to enable resolution of each occurrence.

The average time of occupancy in the specified 31.6 second period (79 channels * 0.4 s) is equal to $10 * (\# \text{ of pulses in } 3.16 \text{ s}) * \text{ pulse width}$.

For AFH mode, the average time of occupancy in the specified 8 second period (20 channels * 0.4 seconds) is equal to $10 * (\# \text{ of pulses in } 0.8 \text{ s}) * \text{ pulse width}$.

RESULTS

DH Packet	Pulse Width (msec)	Number of Pulses in 3.16 seconds	Average Time of Occupancy (sec)	Limit (sec)	Margin (sec)
GFSK Normal Mode					
DH1	0.4167	31	0.129	0.4	-0.271
DH3	1.66	17	0.282	0.4	-0.118
DH5	2.887	8	0.231	0.4	-0.169
GFSK AFH Mode					
DH Packet	Pulse Width (msec)	Number of Pulses in 0.8 seconds	Average Time of Occupancy (sec)	Limit (sec)	Margin (sec)
DH1	0.4167	64	0.267	0.4	-0.133
DH3	1.66	21	0.349	0.4	-0.051
DH5	2.887	13	0.375	0.4	-0.025

PULSE WIDTH - DH1

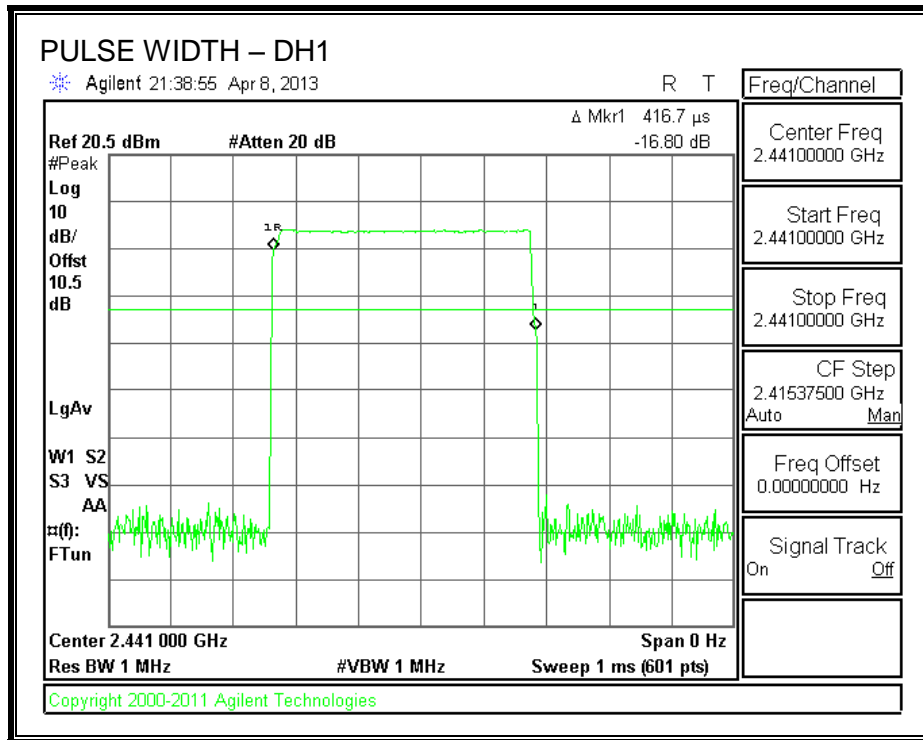

NUMBER OF PULSES IN 3.16 SECOND OBSERVATION PERIOD - DH1

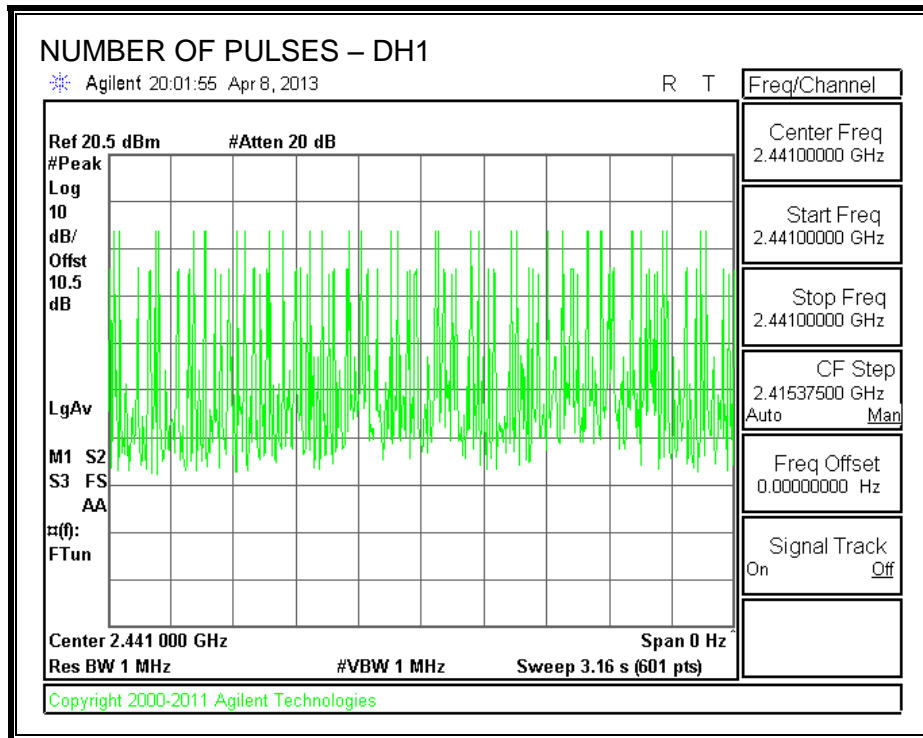

PULSE WIDTH – DH3

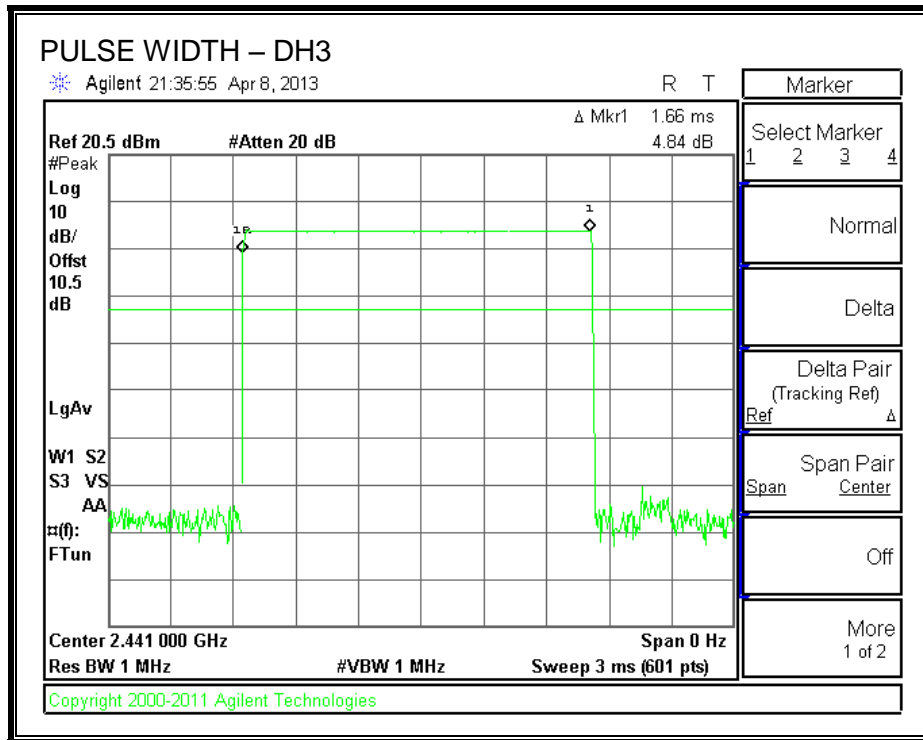

NUMBER OF PULSES IN 3.16 SECOND OBSERVATION PERIOD – DH3

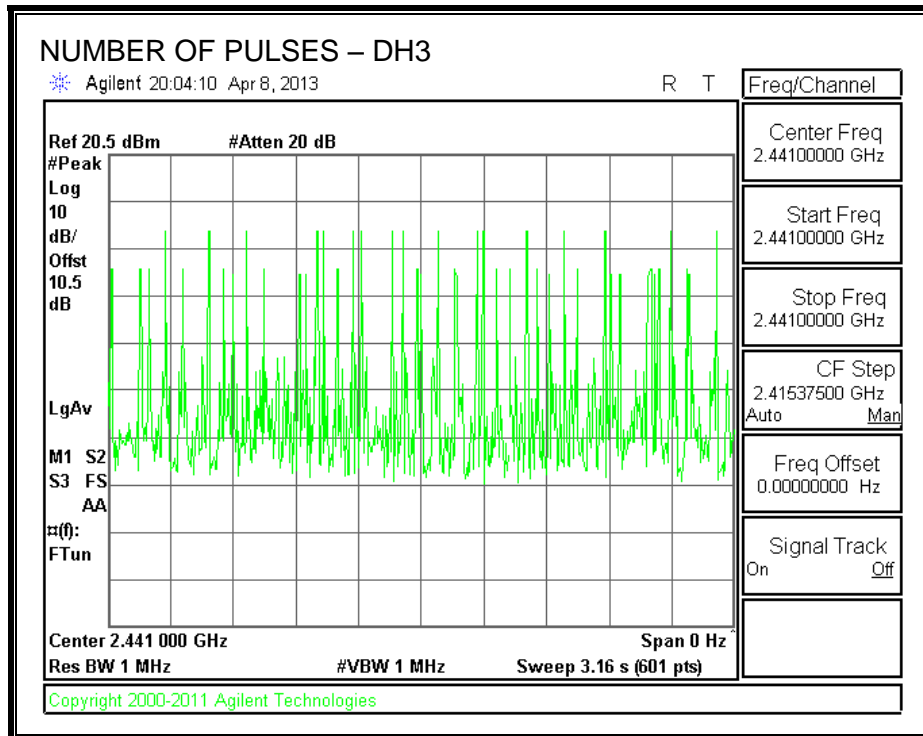

PULSE WIDTH – DH5

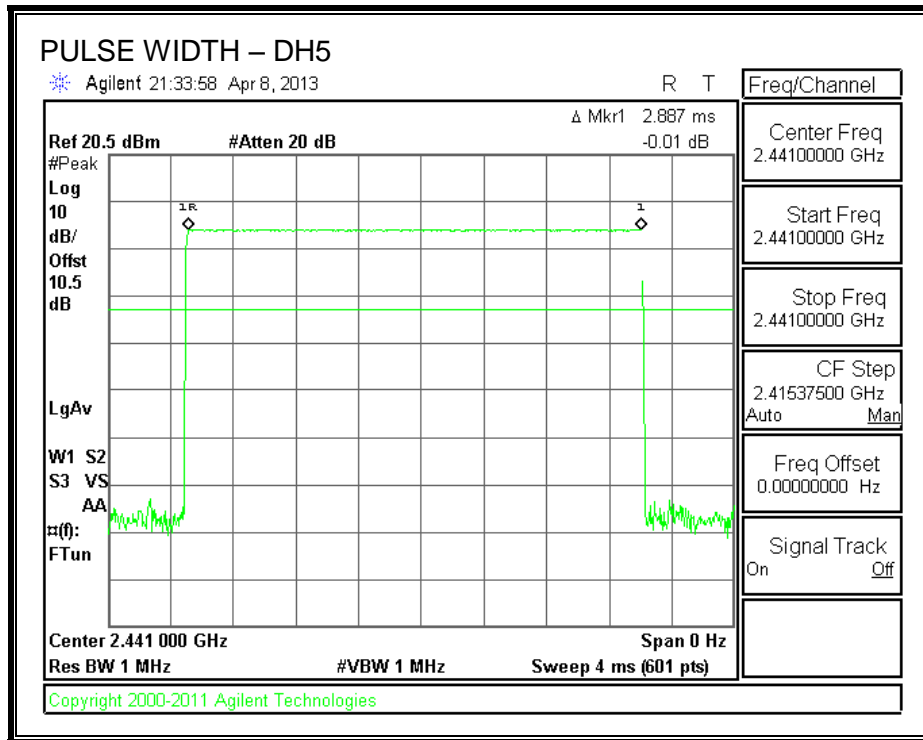

NUMBER OF PULSES IN 3.16 SECOND OBSERVATION PERIOD – DH5

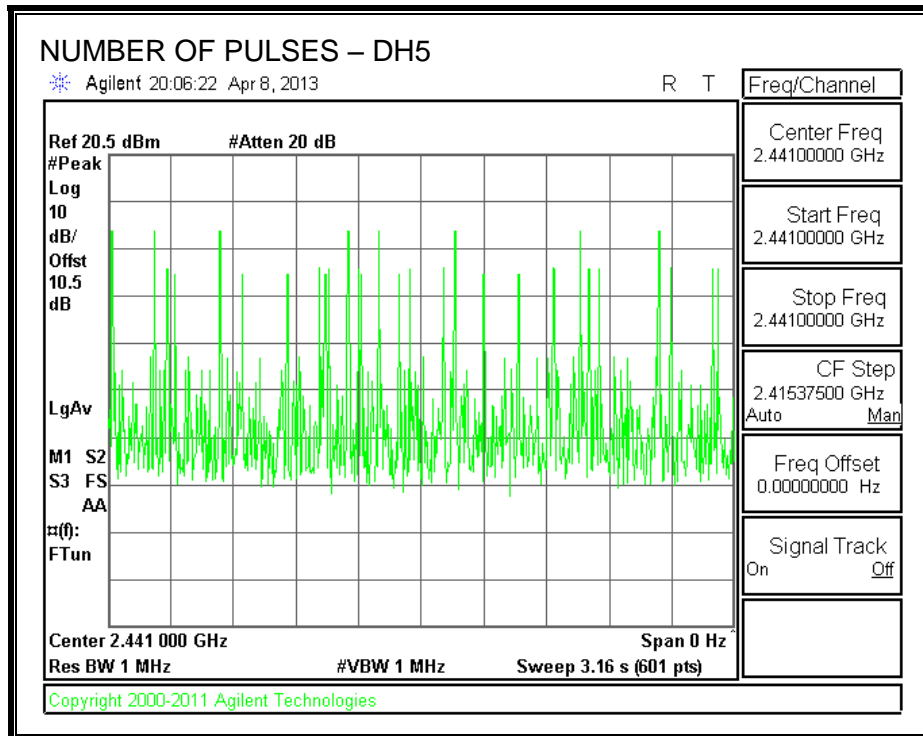

7.3. OUTPUT POWER

LIMIT

§15.247 (b) (1)

RSS-210 Issue 7 Clause A8.4

The maximum antenna gain is less than 6 dBi, therefore the limit is 30 dBm.

TEST PROCEDURE

The transmitter output is connected to a spectrum analyzer the analyzer bandwidth is set to a value greater than the 20 dB bandwidth of the EUT.

RESULTS

Channel	Frequency (MHz)	Output Power (dBm)	Limit (dBm)	Margin (dB)
Low	2402	4.56	30	-25.44
Middle	2441	4.96	30	-25.04
High	2480	5.81	30	-24.19

OUTPUT POWER

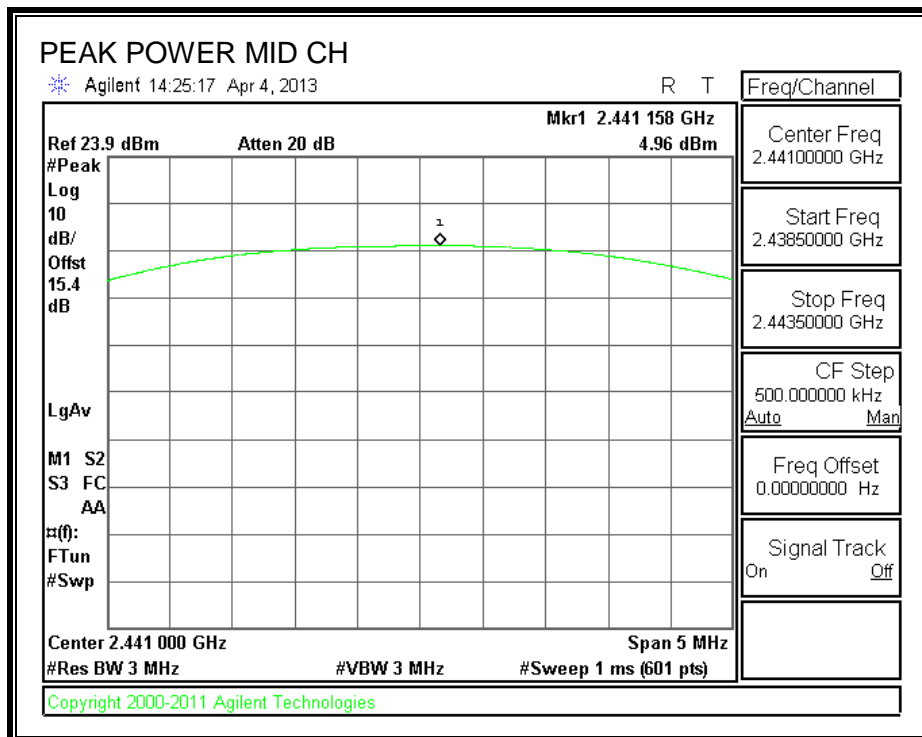
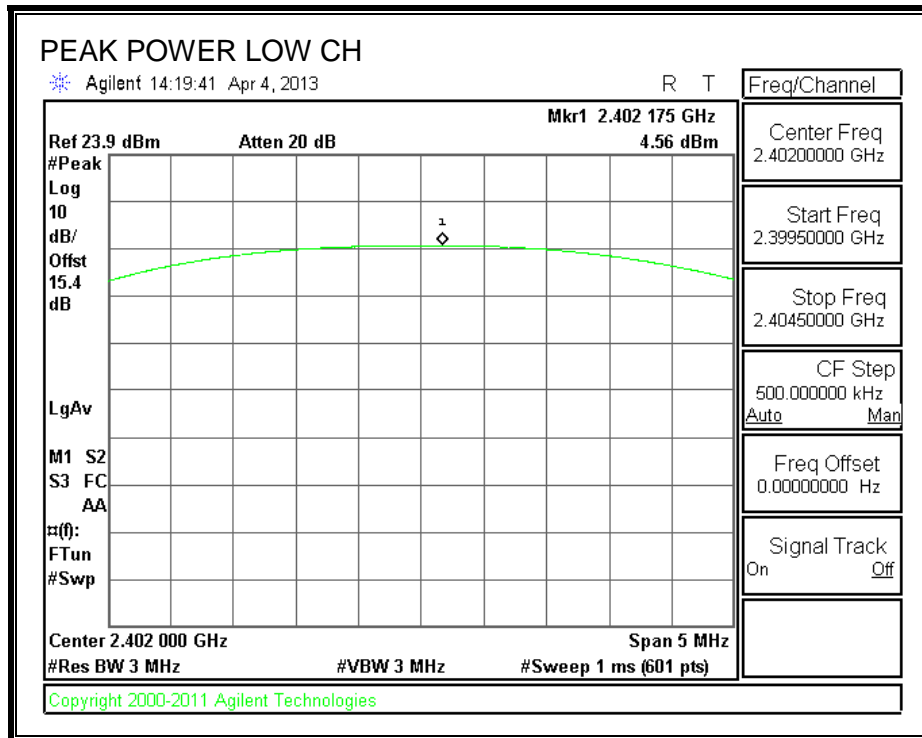

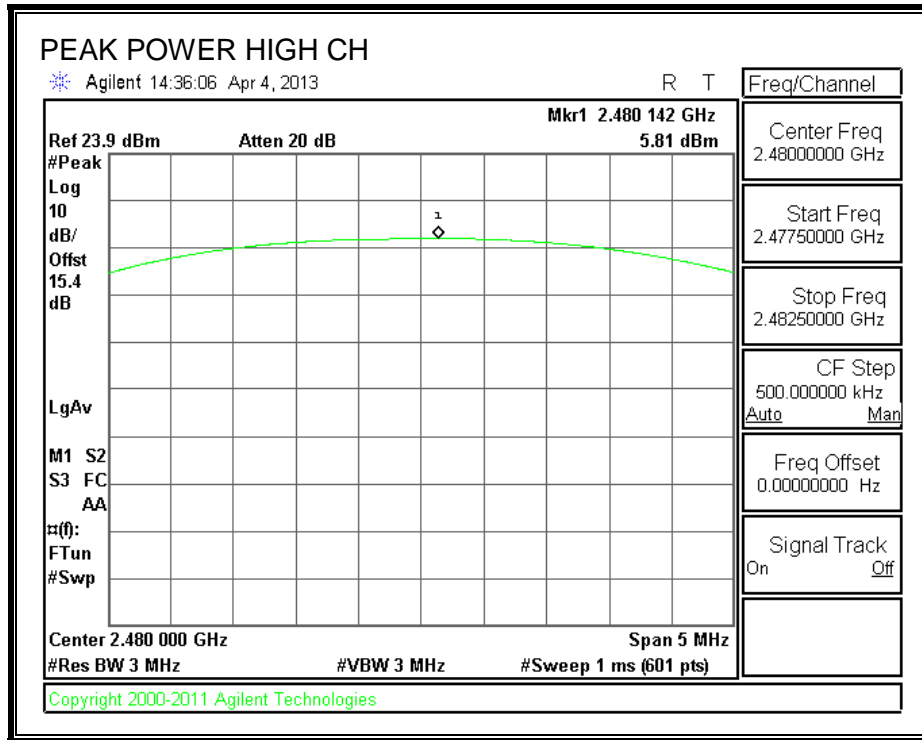

7.4. AVERAGE POWER

LIMIT

None; for reporting purposes only.

TEST PROCEDURE

The transmitter output is connected to a power meter.

RESULTS

The cable assembly insertion loss of 11 dB (including 10 dB pad and 1 dB cable) was entered as an offset in the power meter to allow for direct reading of power.

Channel	Frequency (MHz)	Average Power (dBm)
Low	2402	3.50
Middle	2441	4.10
High	2480	4.80

7.4.1. CONDUCTED SPURIOUS EMISSIONS

LIMITS

FCC §15.247 (d)

IC RSS-210 A8.5

Limit = -20 dBc

TEST PROCEDURE

The transmitter output is connected to a spectrum analyzer. The resolution bandwidth is set to 100 kHz. The video bandwidth is set to 300 kHz.

The spectrum from 30 MHz to 26 GHz is investigated with the transmitter set to the lowest, middle, and highest channels.

The bandedges at 2.4 and 2.4835 GHz are investigated with the transmitter set to the normal hopping mode.

RESULTS

SPURIOUS EMISSIONS, LOW CHANNEL

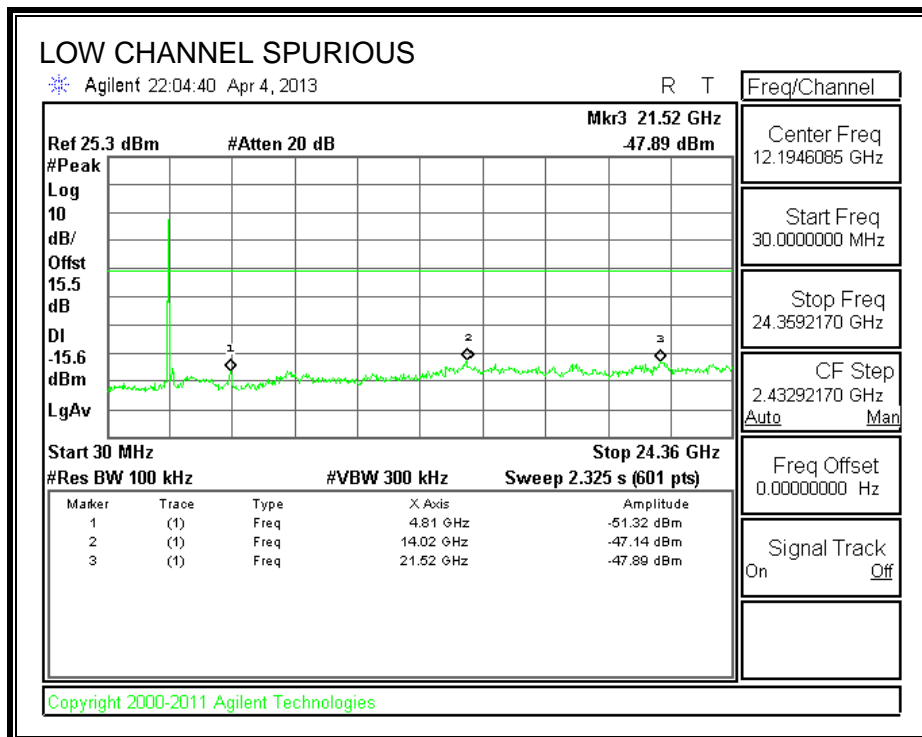
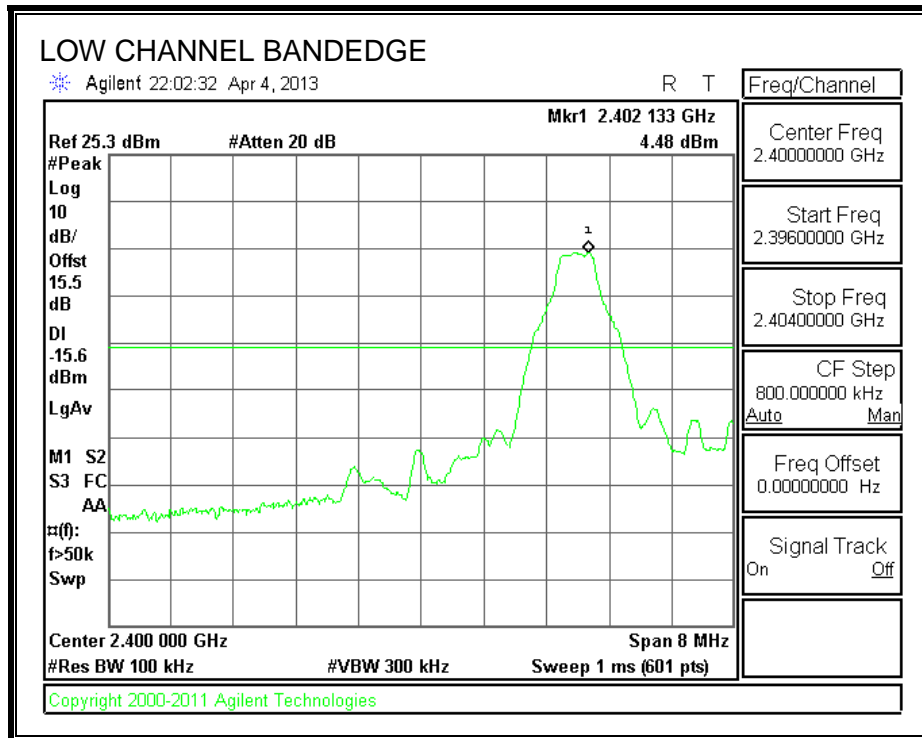

SPURIOUS EMISSIONS, MID CHANNEL

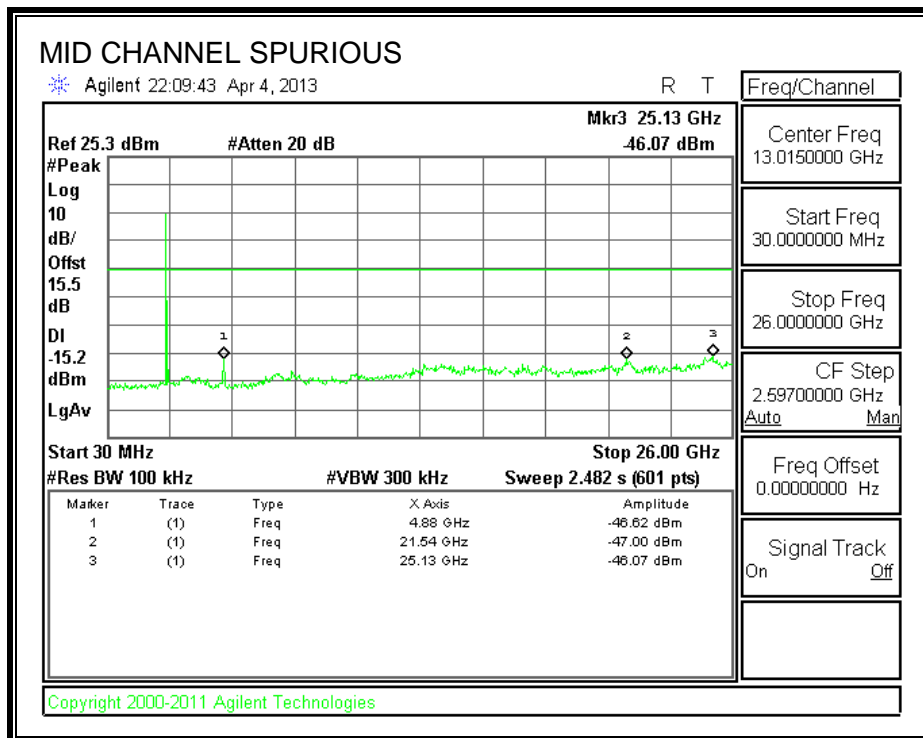
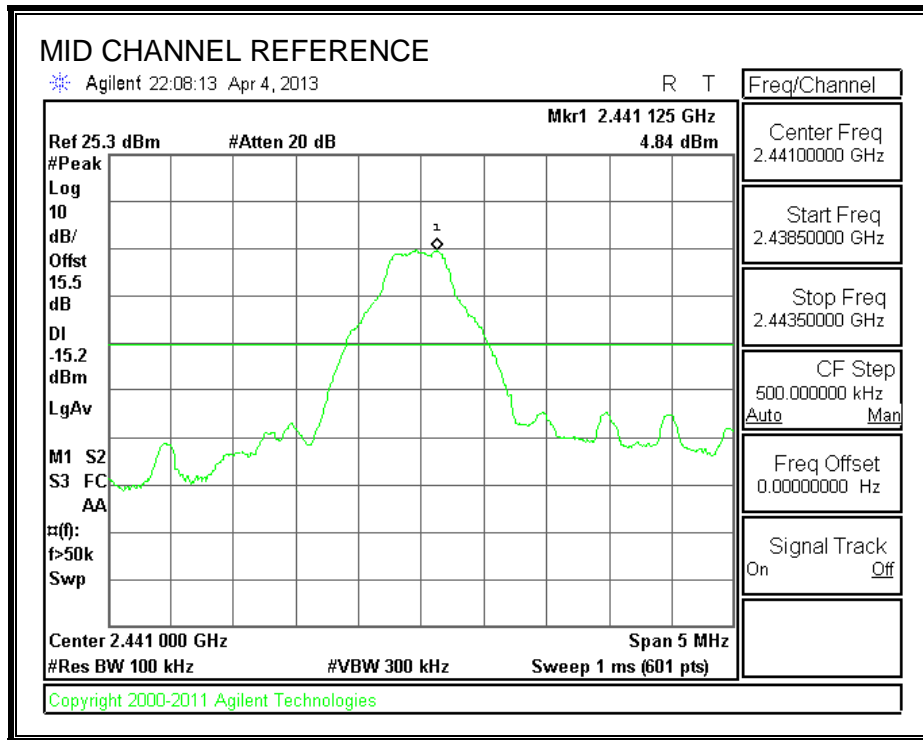

SPURIOUS EMISSIONS, HIGH CHANNEL

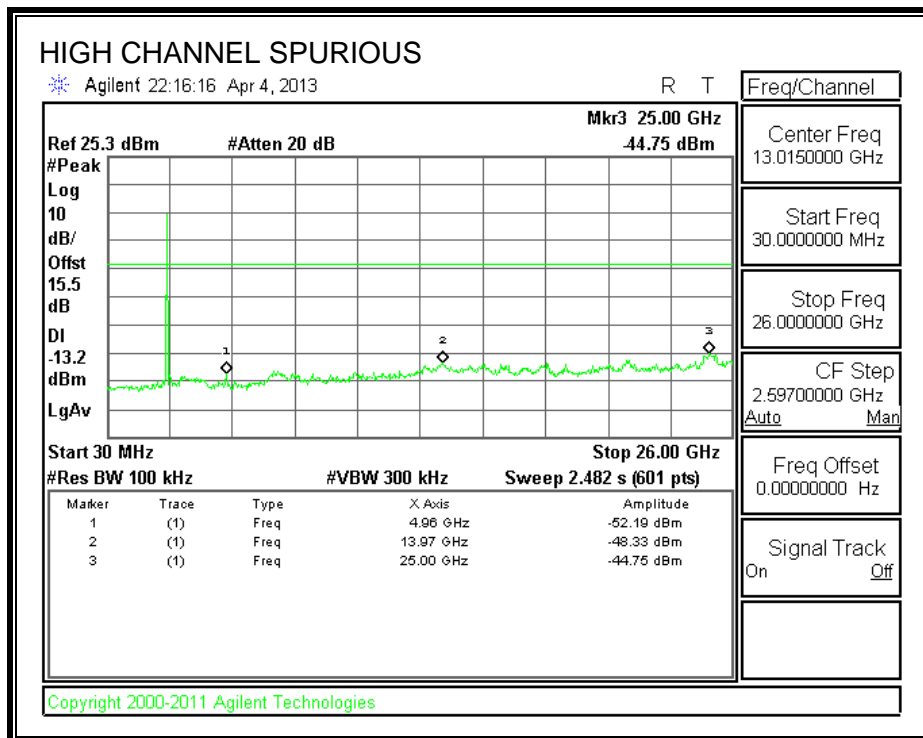
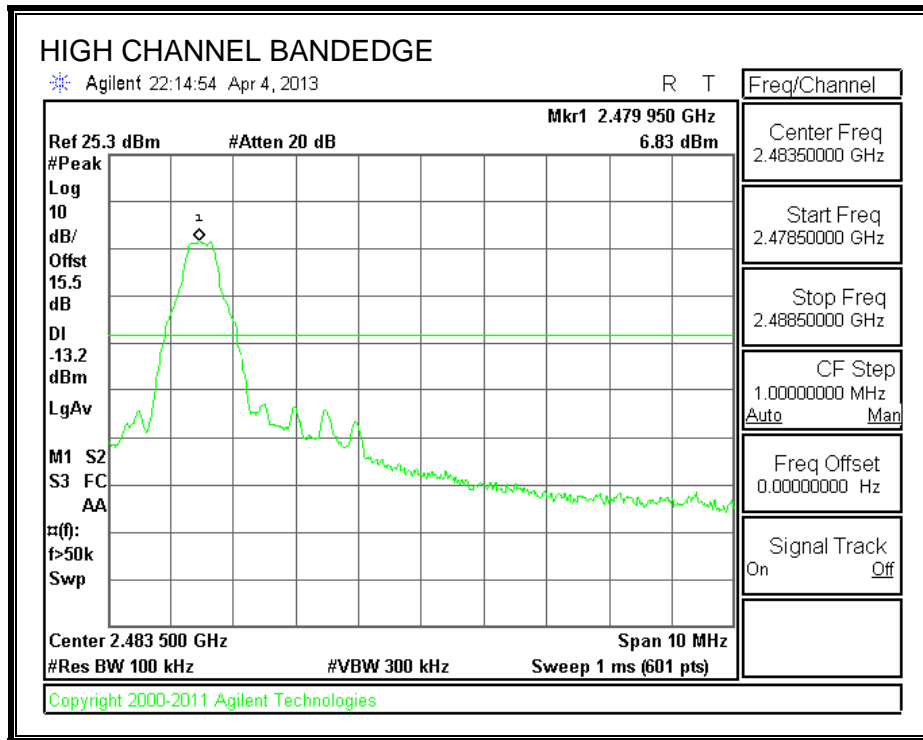

SPURIOUS BANDEGE EMISSIONS WITH HOPPING ON

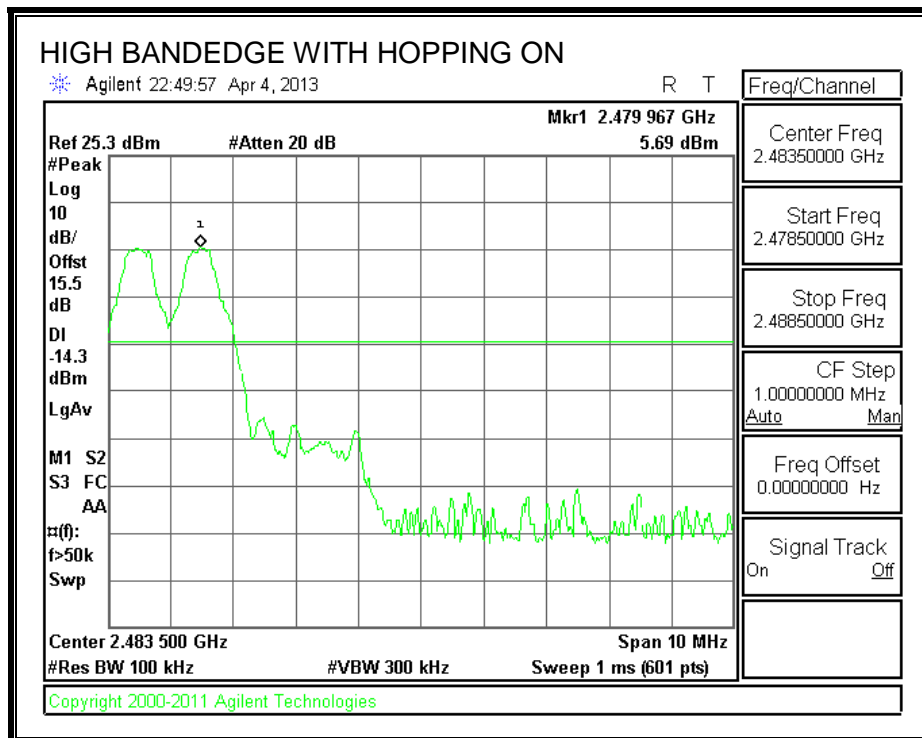
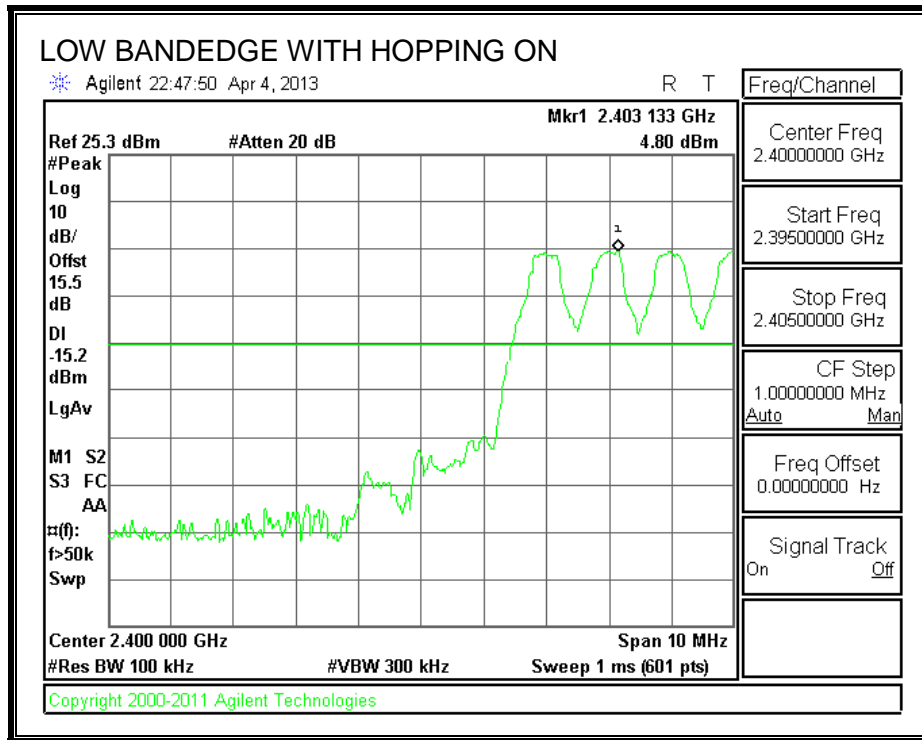

7.5. ENHANCED DATA RATE 8PSK MODULATION

7.5.1. 20 dB AND 99% BANDWIDTH

LIMIT

None; for reporting purposes only.

TEST PROCEDURE

The transmitter output is connected to a spectrum analyzer. The RBW is set to $\geq 1\%$ of the 20 dB bandwidth. The VBW is set to \geq RBW. The sweep time is coupled.

RESULTS

Channel	Frequency (MHz)	20 dB Bandwidth (kHz)	99% Bandwidth (kHz)
Low	2402	1317	1216.3
Middle	2441	1247	1171.7
High	2480	1275	1206.3

20 dB AND 99% BANDWIDTH

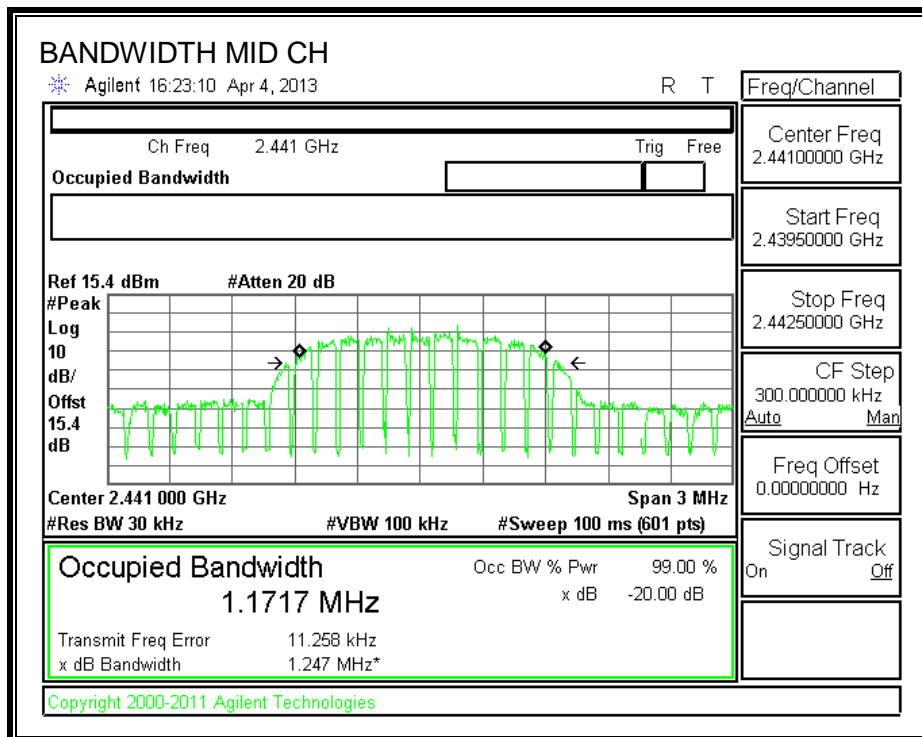
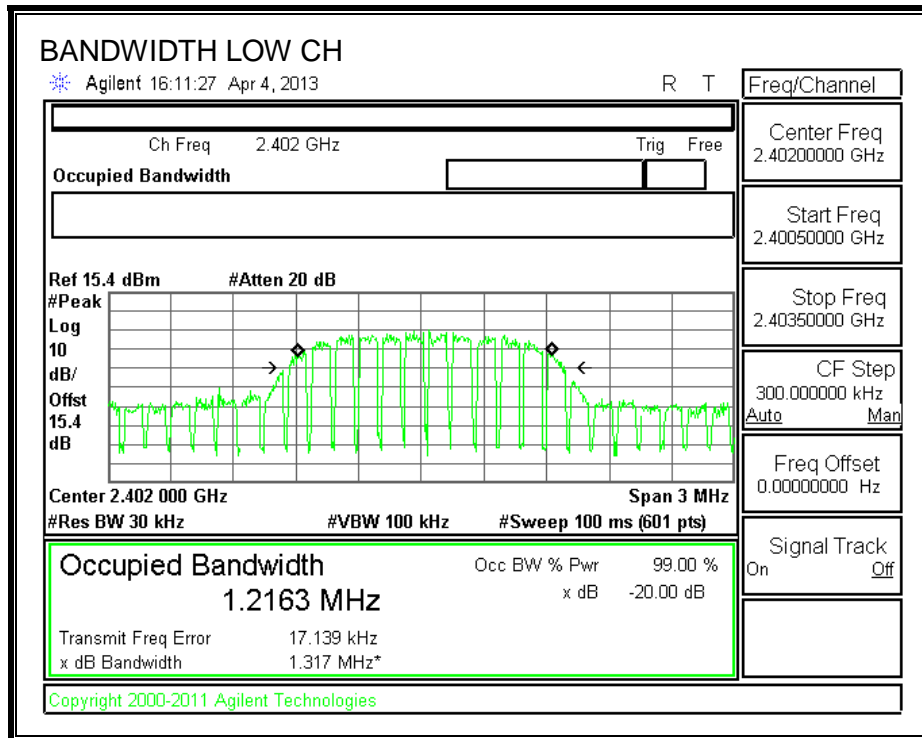

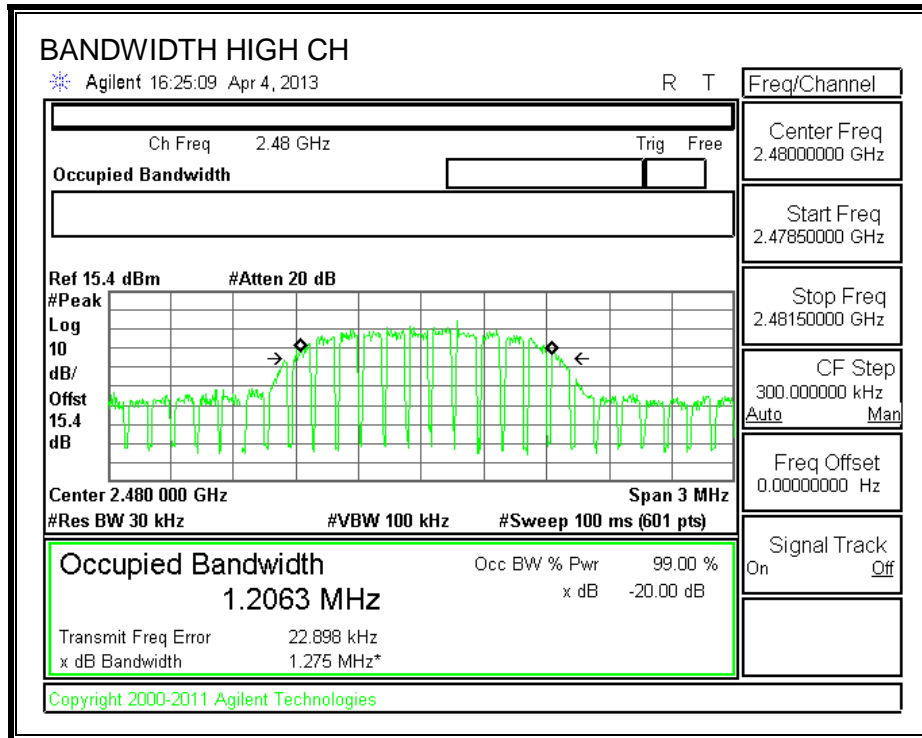

7.5.2. HOPPING FREQUENCY SEPARATION

LIMIT

FCC §15.247 (a) (1)

IC RSS-210 A8.1 (b)

Frequency hopping systems shall have hopping channel carrier frequencies separated by a minimum of 25 kHz or the 20 dB bandwidth of the hopping channel, whichever is greater.

Alternatively, frequency hopping systems operating in the 2400-2483.5 MHz band may have hopping channel carrier frequencies that are separated by 25 kHz or two-thirds of the 20 dB bandwidth of the hopping channel, whichever is greater, provided the systems operate with an output power no greater than 125 mW.

TEST PROCEDURE

The transmitter output is connected to a spectrum analyzer. The RBW is set to 100 kHz and the VBW is set to 100 kHz. The sweep time is coupled.

RESULTS

HOPPING FREQUENCY SEPARATION

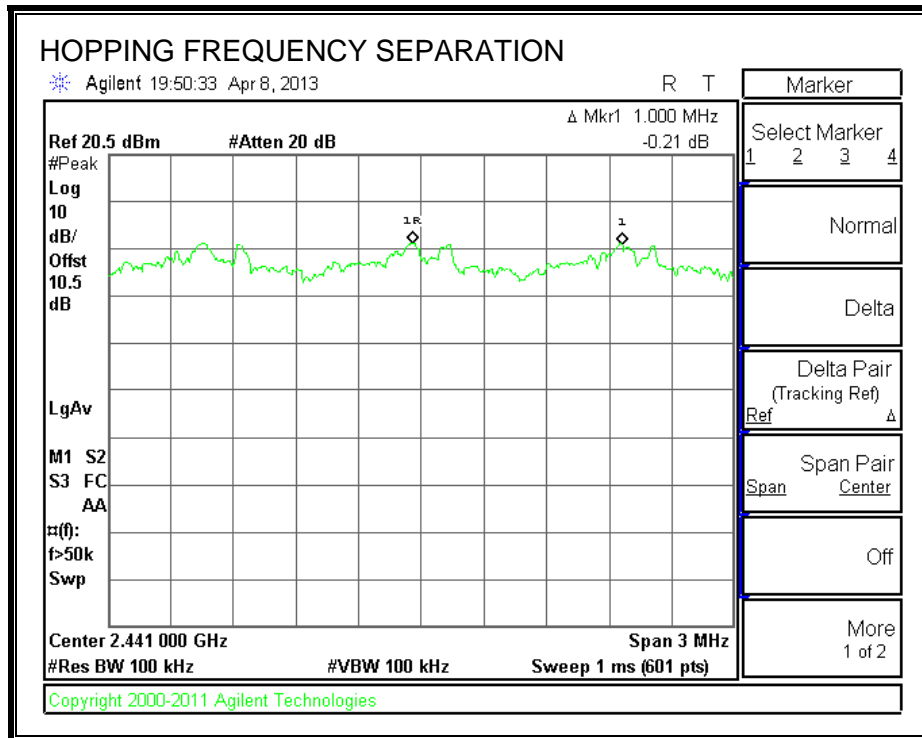

7.5.3. NUMBER OF HOPPING CHANNELS

LIMIT

FCC §15.247 (a) (1) (iii)

IC RSS-210 A8.1 (d)

Frequency hopping systems in the 2400 – 2483.5 MHz band shall use at least 15 non-overlapping channels.

TEST PROCEDURE

The transmitter output is connected to a spectrum analyzer. The span is set to cover the entire authorized band, in either a single sweep or in multiple contiguous sweeps. The RBW is set to a maximum of 1 % of the span. The analyzer is set to Max Hold.

RESULTS

Normal Mode: 79 Channels observed.

NUMBER OF HOPPING CHANNELS

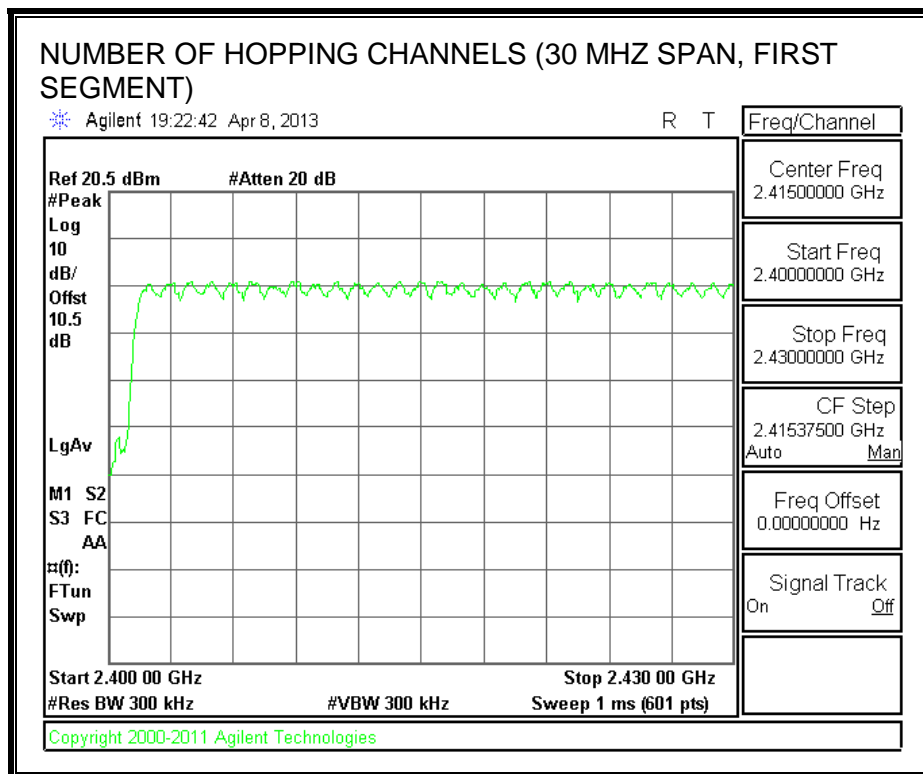
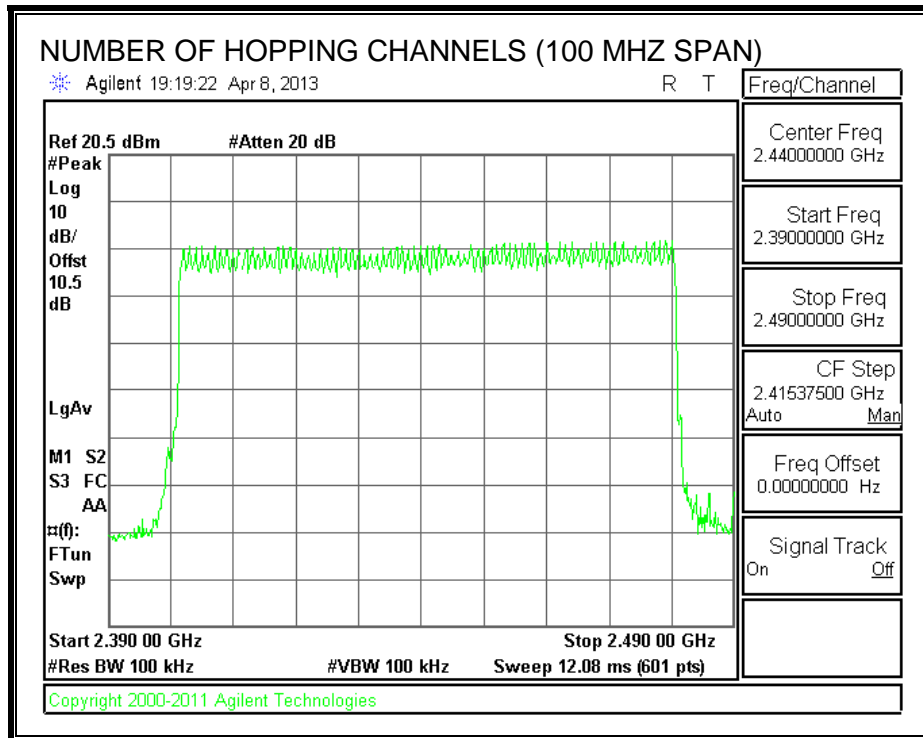

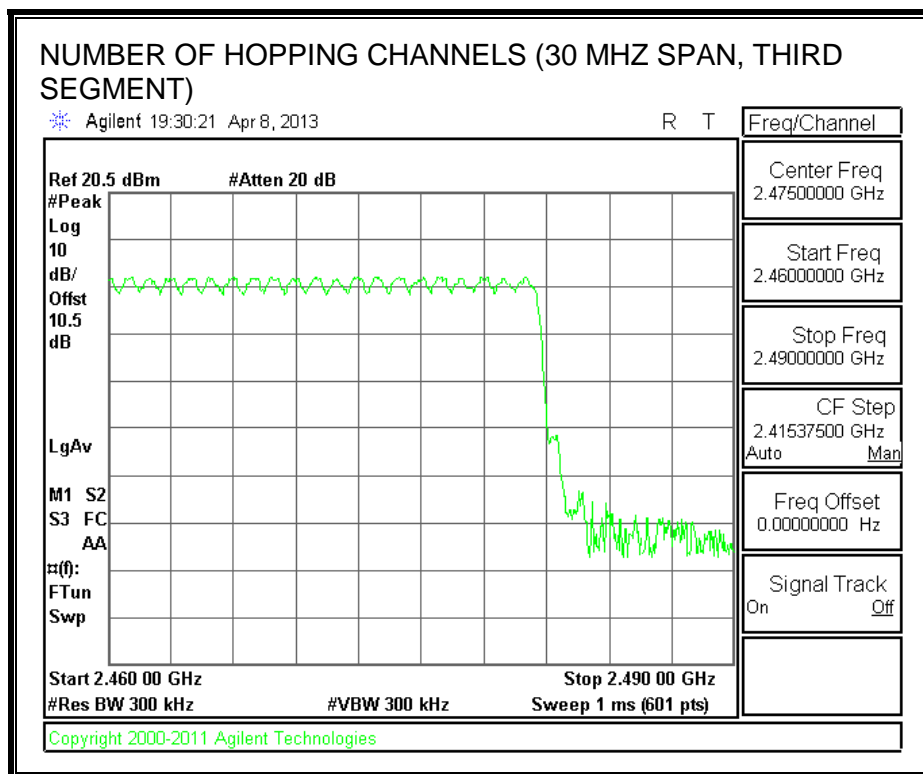
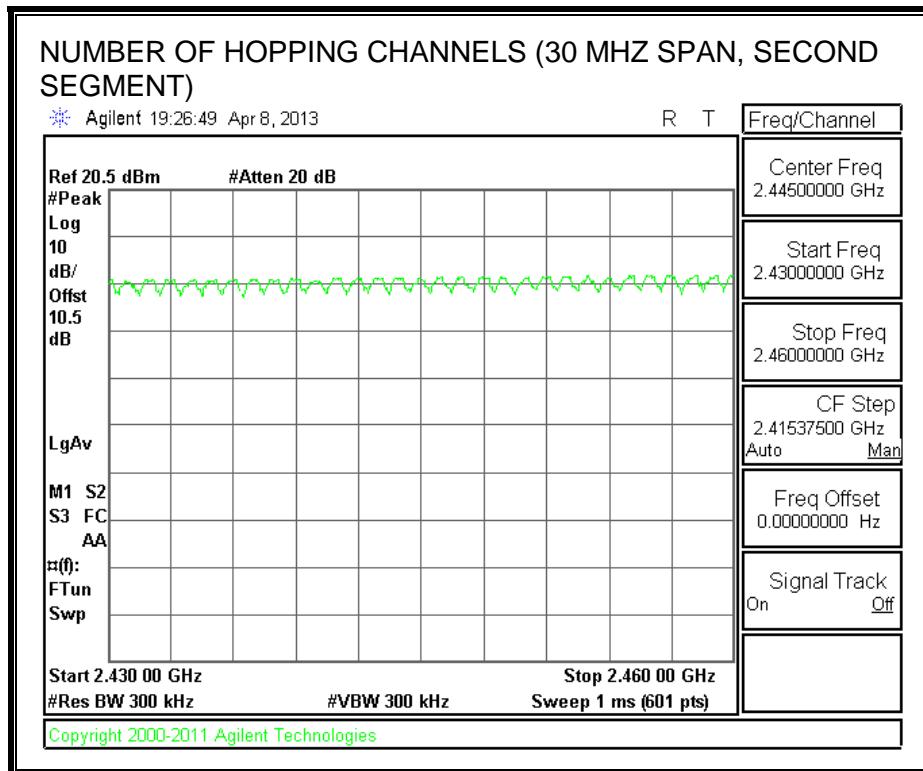

7.5.4. AVERAGE TIME OF OCCUPANCY

LIMIT

FCC §15.247 (a) (1) (iii)

IC RSS-210 A8.1 (d)

The average time of occupancy on any channel shall not be greater than 0.4 seconds within a period of 0.4 seconds multiplied by the number of hopping channels employed.

TEST PROCEDURE

The transmitter output is connected to a spectrum analyzer. The span is set to 0 Hz, centered on a single, selected hopping channel. The width of a single pulse is measured in a fast scan. The number of pulses is measured in a 3.16 second scan, to enable resolution of each occurrence.

The average time of occupancy in the specified 31.6 second period (79 channels * 0.4 s) is equal to $10 * (\# \text{ of pulses in } 3.16 \text{ s}) * \text{ pulse width}$.

RESULTS

DH Packet	Pulse Width (msec)	Number of Pulses in 3.16 seconds	Average Time of (sec)	Limit (sec)	Margin (sec)
DH1	0.4333	31	0.134	0.4	-0.266
DH3	1.635	14	0.229	0.4	-0.171
DH5	2.92	11	0.321	0.4	-0.079

PULSE WIDTH - DH1

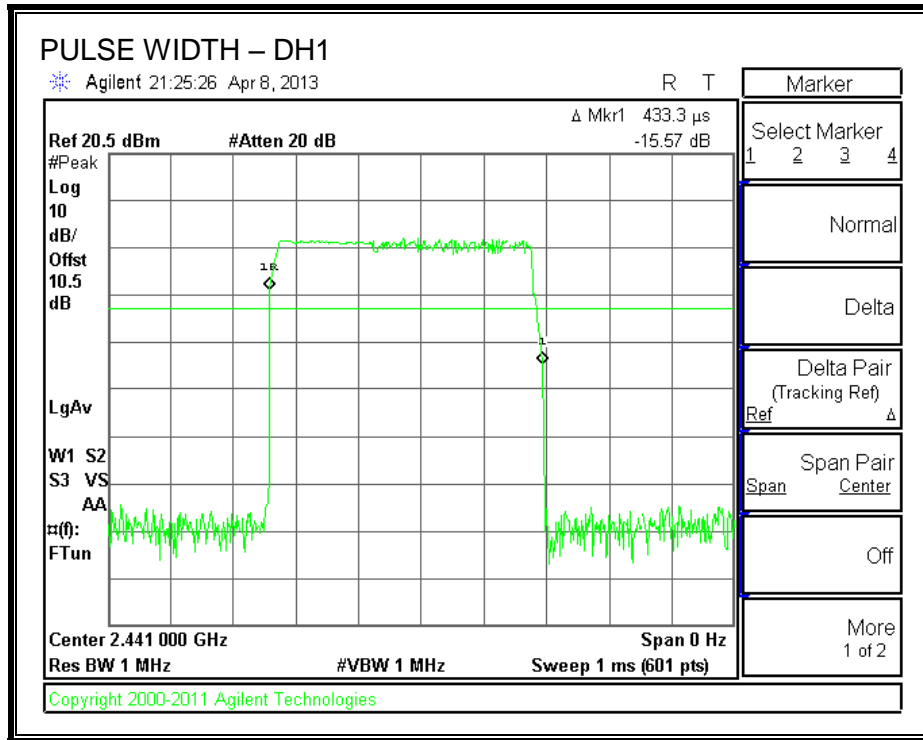

NUMBER OF PULSES IN 3.16 SECOND OBSERVATION PERIOD – DH1

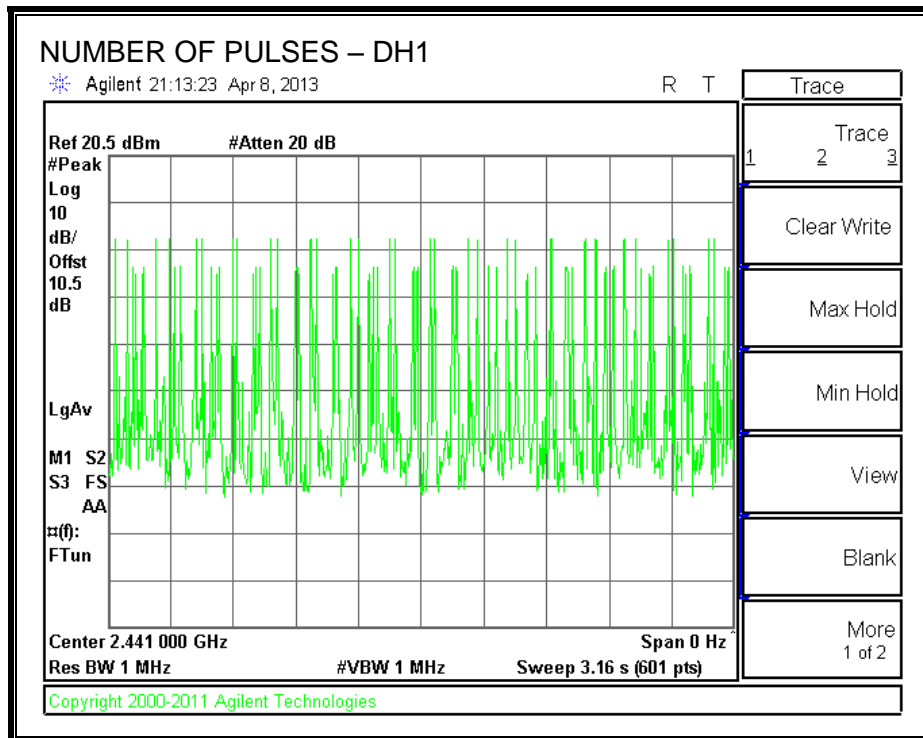

PULSE WIDTH – DH3

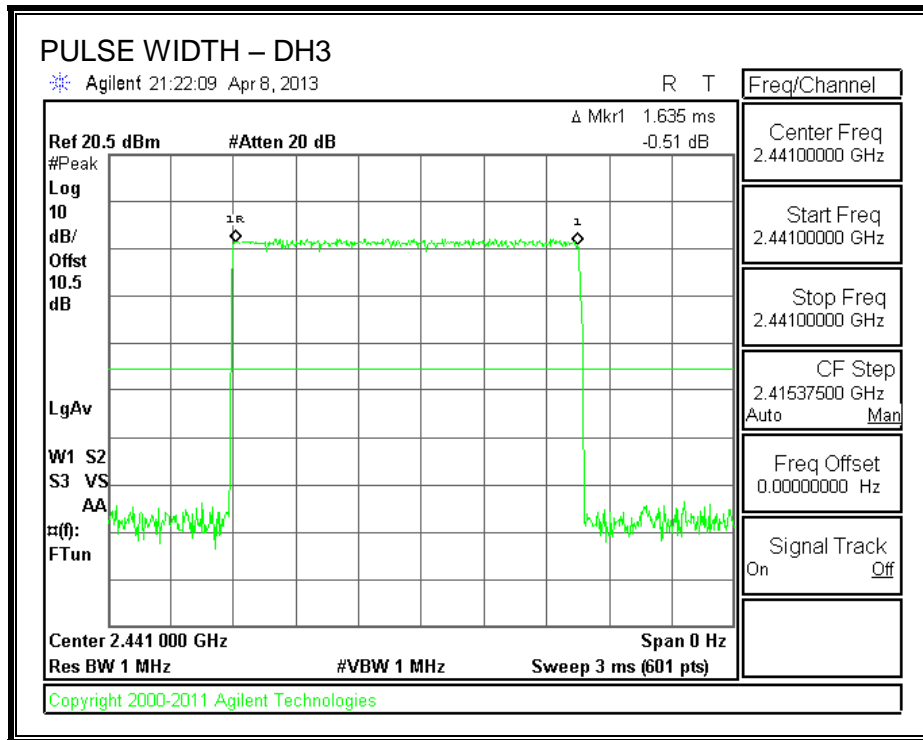

NUMBER OF PULSES IN 3.16 SECOND OBSERVATION PERIOD – DH3

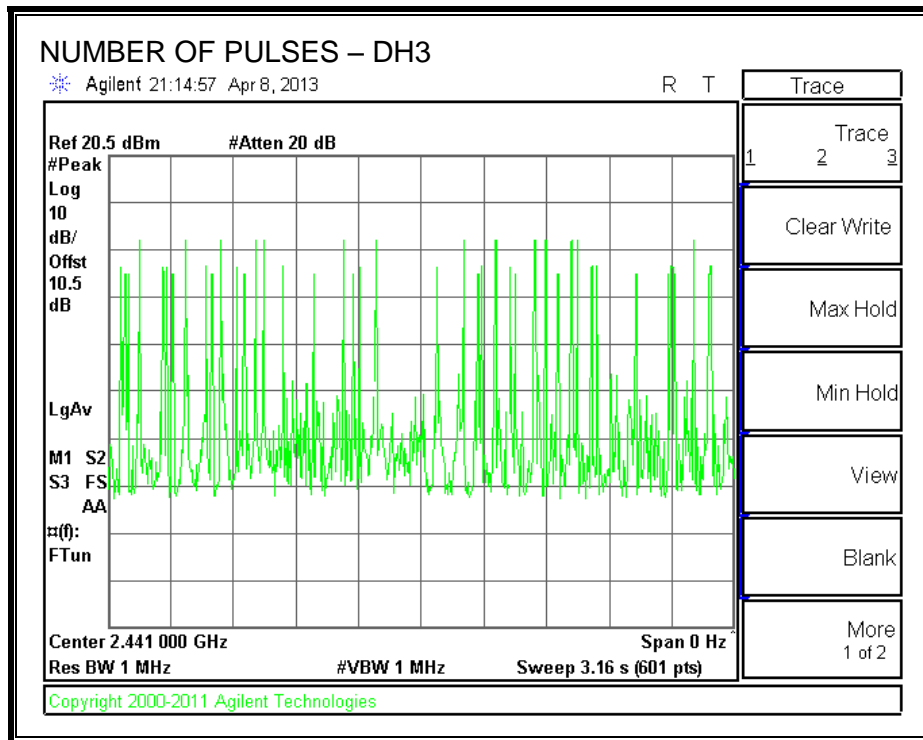

PULSE WIDTH – DH5

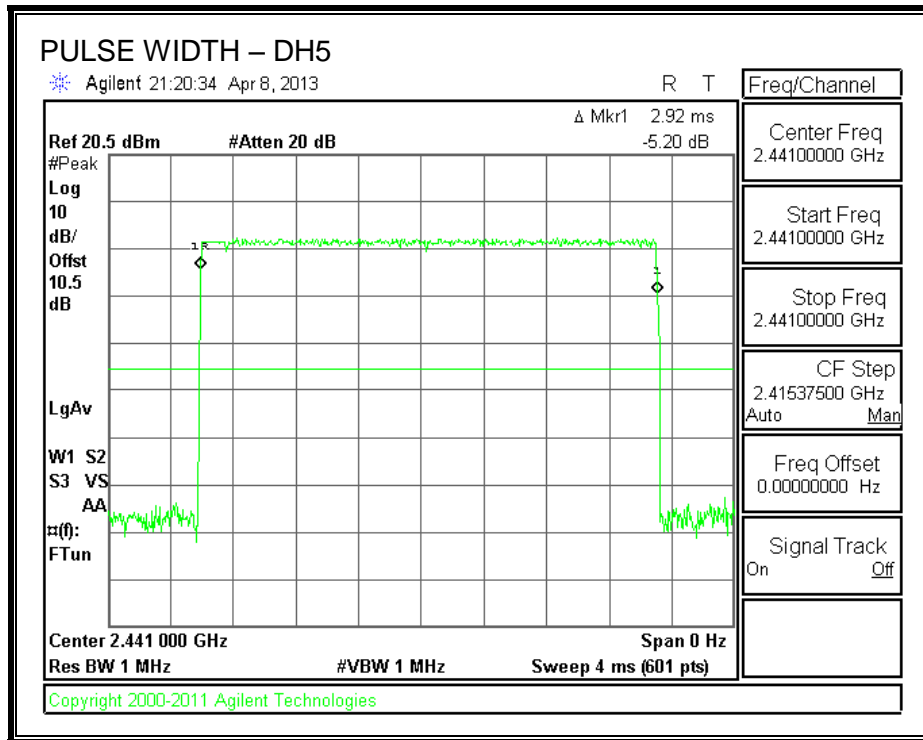

NUMBER OF PULSES IN 3.16 SECOND OBSERVATION PERIOD – DH5

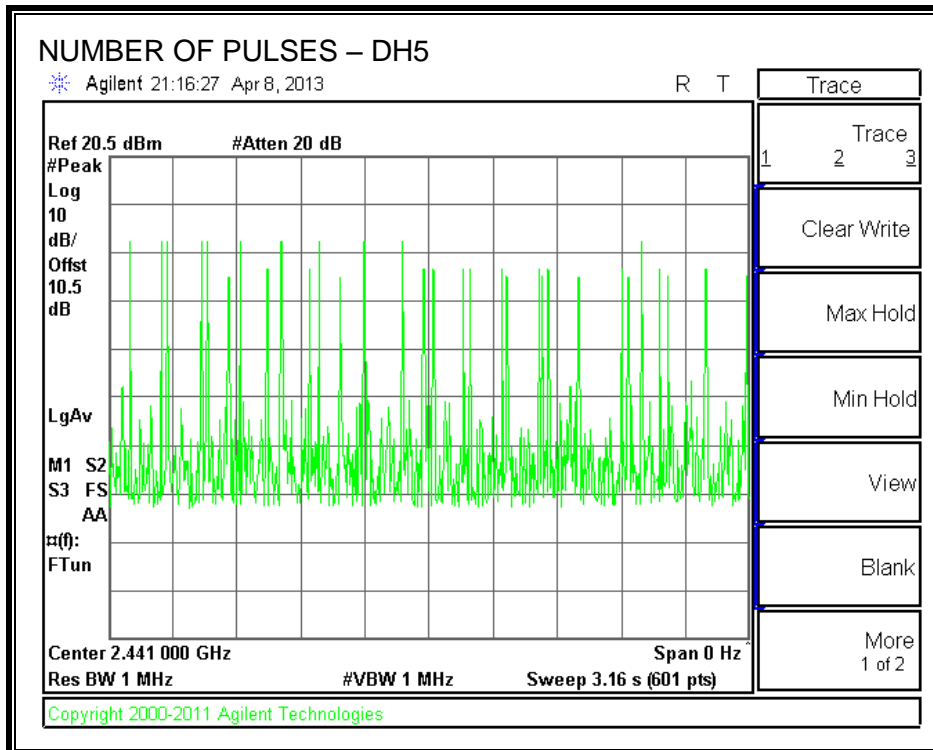

7.5.5. OUTPUT POWER

LIMIT

§15.247 (b) (1)

RSS-210 Issue 7 Clause A8.4

The maximum antenna gain is less than 6 dBi, therefore the limit is 30 dBm.

TEST PROCEDURE

The transmitter output is connected to a spectrum analyzer the analyzer bandwidth is set to a value greater than the 20 dB bandwidth of the EUT.

RESULTS

Channel	Frequency (MHz)	Output Power (dBm)	Limit (dBm)	Margin (dB)
Low	2402	3.21	30	-26.79
Middle	2441	3.98	30	-26.02
High	2480	5.89	30	-24.11

OUTPUT POWER

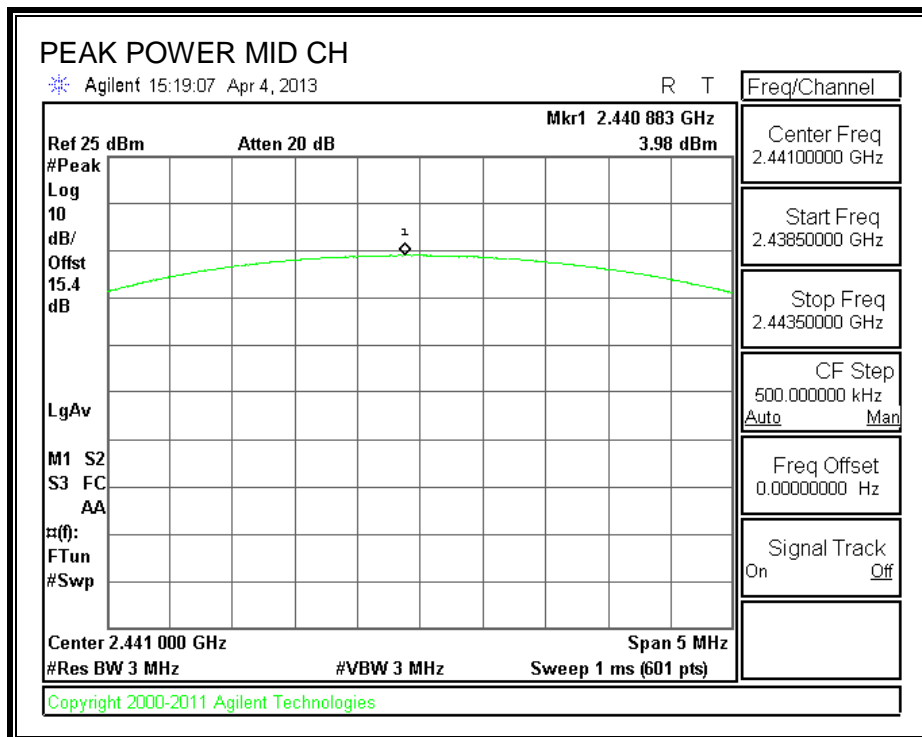
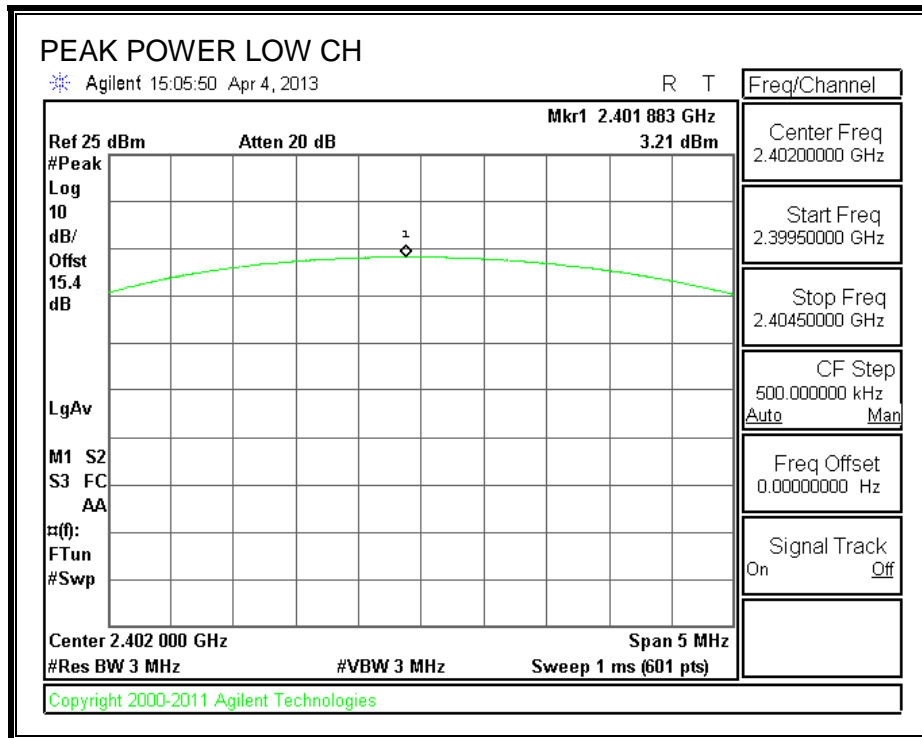

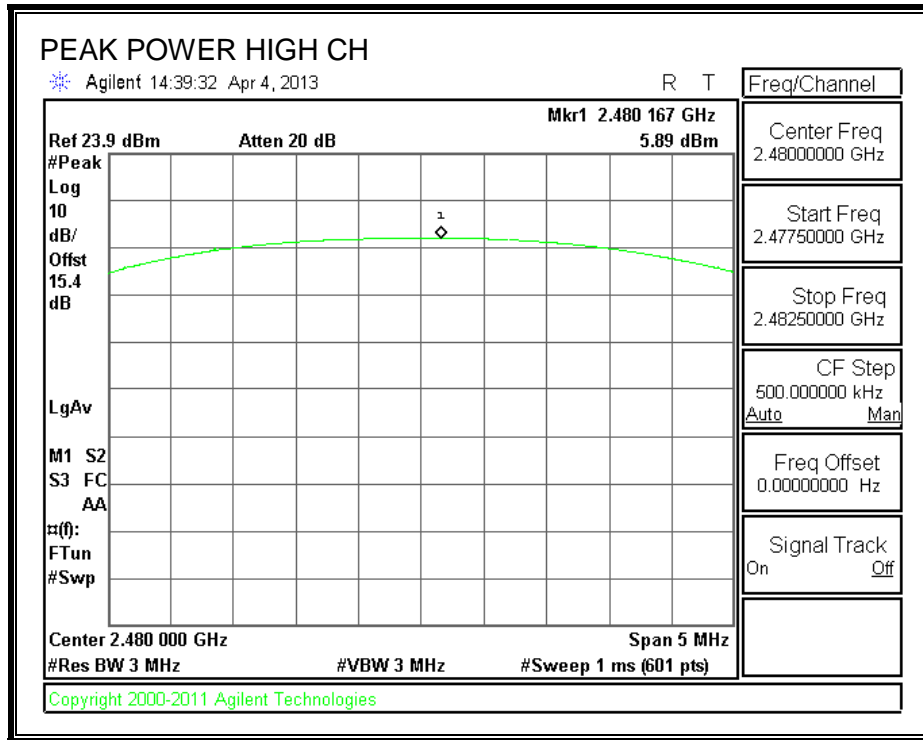

7.5.6. AVERAGE POWER

LIMIT

None; for reporting purposes only.

TEST PROCEDURE

The transmitter output is connected to a power meter.

RESULTS

The cable assembly insertion loss of 11 dB (including 10 dB pad and 1 dB cable) was entered as an offset in the power meter to allow for direct reading of power.

Channel	Frequency (MHz)	Average Power (dBm)
Low	2402	-0.20
Middle	2441	0.40
High	2480	2.40

7.5.7. CONDUCTED SPURIOUS EMISSIONS

LIMITS

FCC §15.247 (d)

IC RSS-210 A8.5

Limit = -20 dBc

TEST PROCEDURE

The transmitter output is connected to a spectrum analyzer. The resolution bandwidth is set to 100 kHz. The video bandwidth is set to 300 kHz.

The spectrum from 30 MHz to 26 GHz is investigated with the transmitter set to the lowest, middle, and highest channels.

The band edges at 2.4 and 2.4835 GHz are investigated with the transmitter set to the normal hopping mode.

RESULTS

SPURIOUS EMISSIONS, LOW CHANNEL

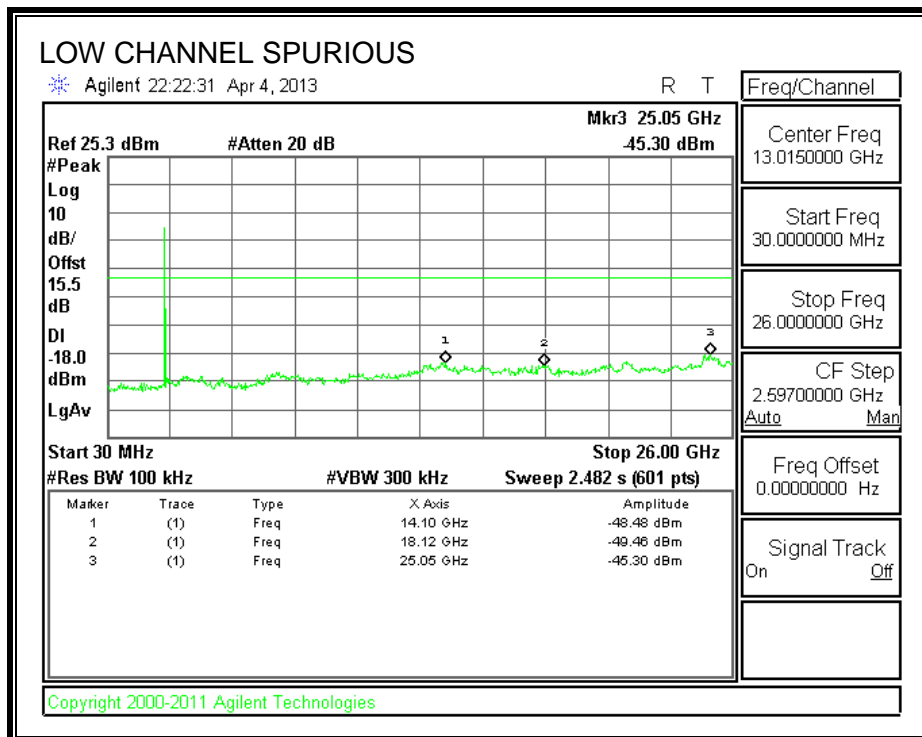
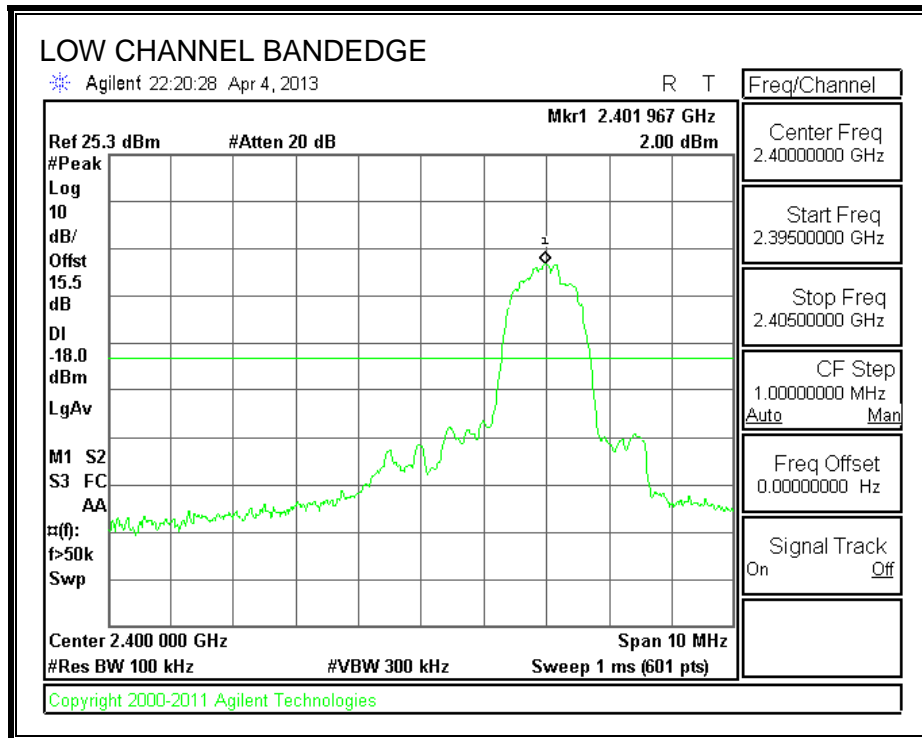

SPURIOUS EMISSIONS, MID CHANNEL

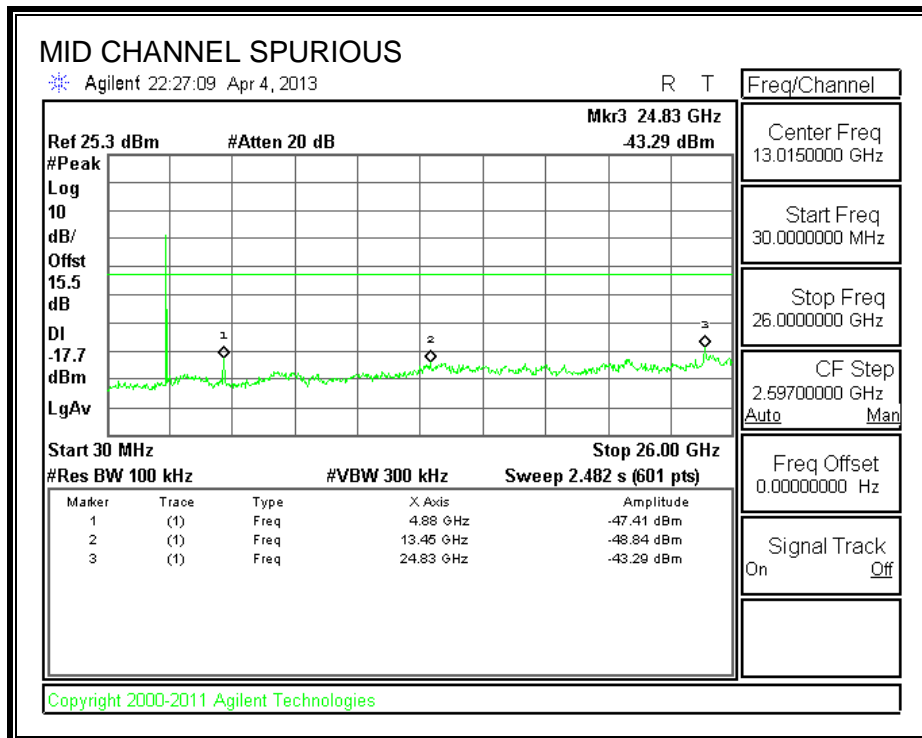
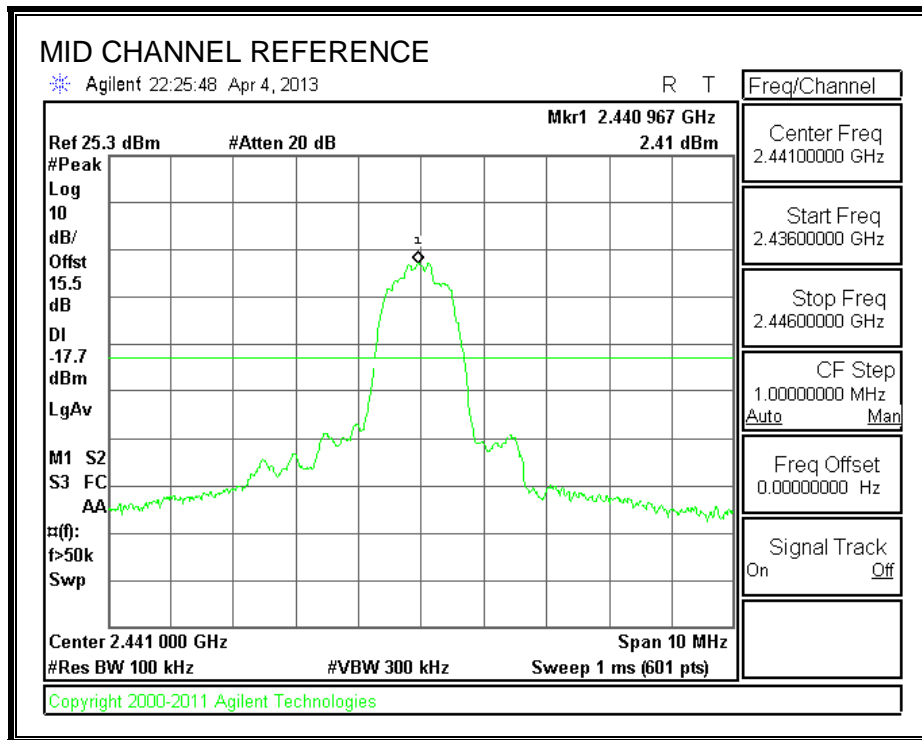

SPURIOUS EMISSIONS, HIGH CHANNEL

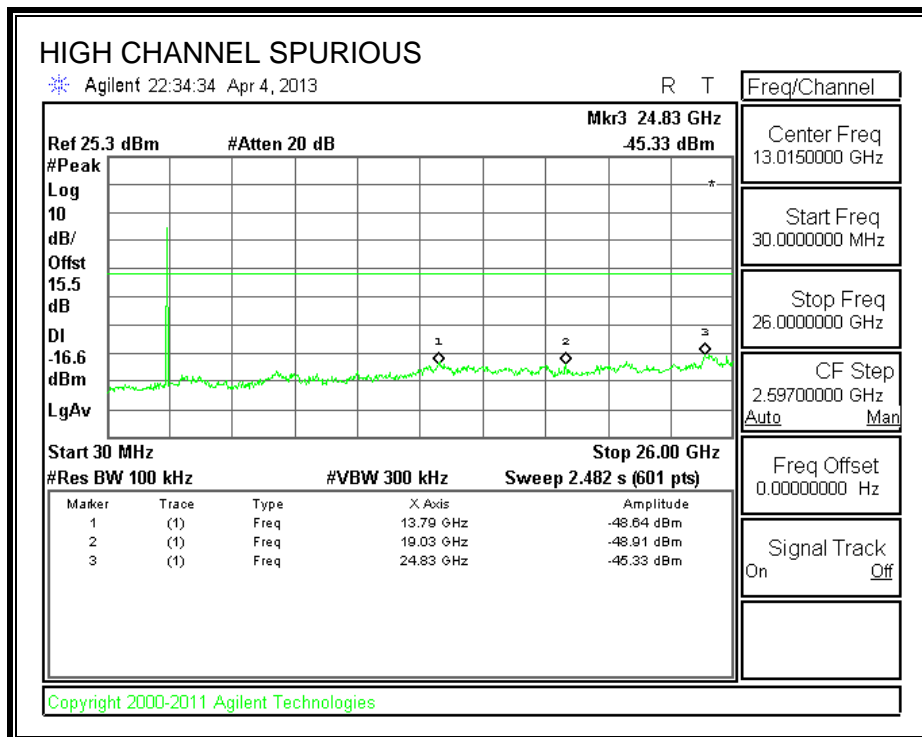
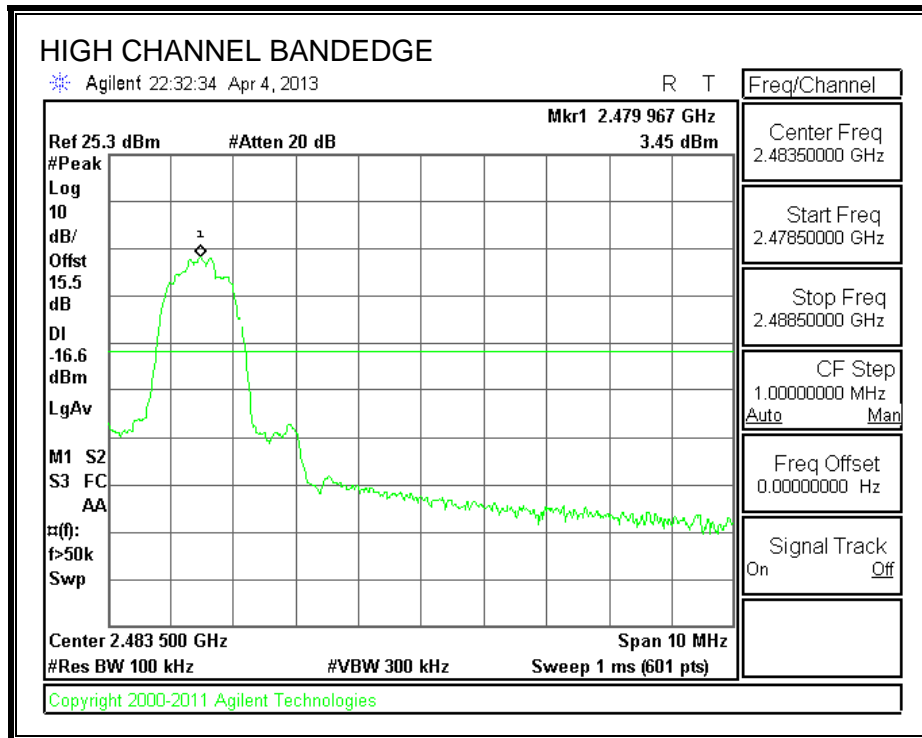

SPURIOUS BANDEGE EMISSIONS WITH HOPPING ON

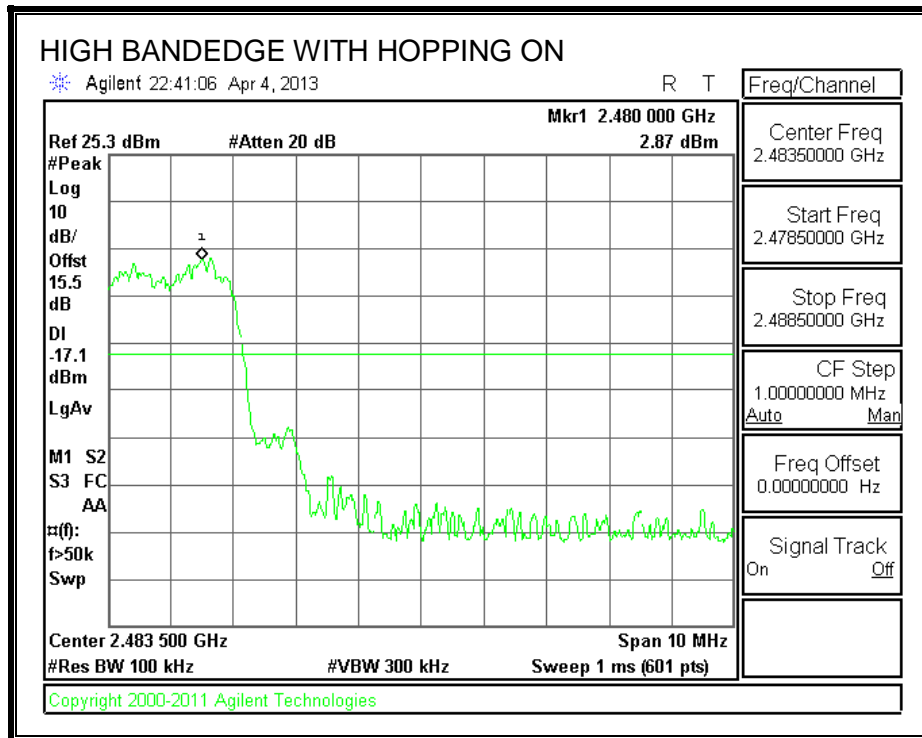
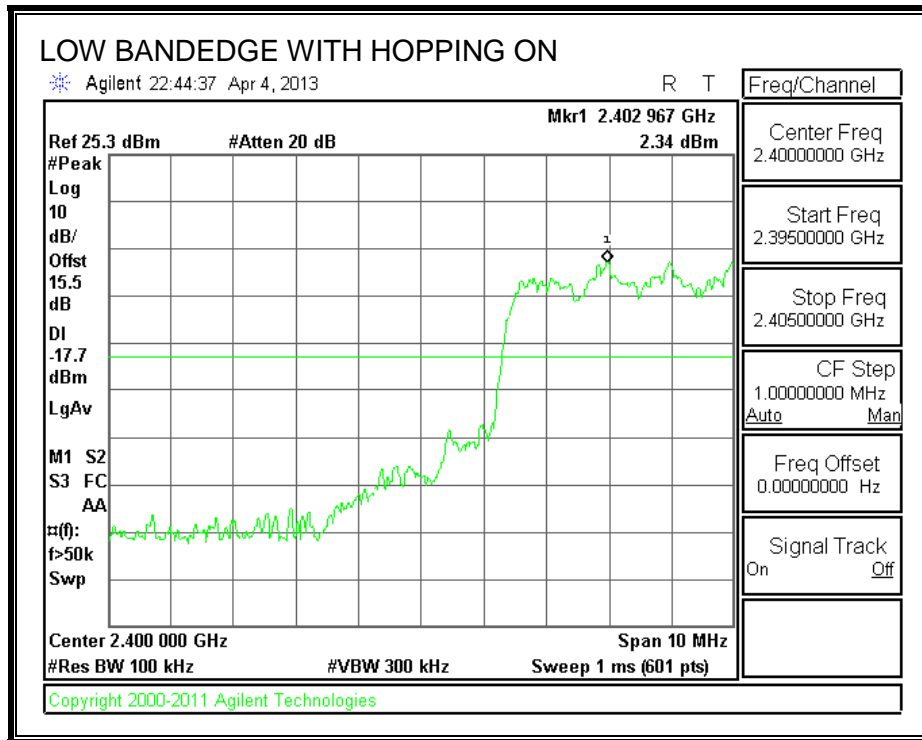

8. RADIATED TEST RESULTS

8.1. LIMITS AND PROCEDURE

LIMITS

FCC §15.205 and §15.209

IC RSS-210 Clause 2.6 (Transmitter)

IC RSS-GEN Clause 6 (Receiver)

Frequency Range (MHz)	Field Strength Limit (uV/m) at 3 m	Field Strength Limit (dBuV/m) at 3 m
30 - 88	100	40
88 - 216	150	43.5
216 - 960	200	46
Above 960	500	54

TEST PROCEDURE

The EUT is placed on a non-conducting table 80 cm above the ground plane. The antenna to EUT distance is 3 meters. The EUT is configured in accordance with ANSI C63.4. The EUT is set to transmit in a continuous mode.

For measurements below 1 GHz the resolution bandwidth is set to 100 kHz for peak detection measurements or 120 kHz for quasi-peak detection measurements. Peak detection is used unless otherwise noted as quasi-peak.

For measurements above 1 GHz the resolution bandwidth is set to 1 MHz, then the video bandwidth is set to 1 MHz for peak measurements and 10 Hz for average measurements.

The spectrum from 30 MHz to 26 GHz is investigated with the transmitter set to the lowest, middle, and highest channels in the 2.4 GHz band.

The frequency range of interest is monitored at a fixed antenna height and EUT azimuth. The EUT is rotated through 360 degrees to maximize emissions received. The antenna is scanned from 1 to 4 meters above the ground plane to further maximize the emission. Measurements are made with the antenna polarized in both the vertical and the horizontal positions.

8.2. TRANSMITTER ABOVE 1 GHz

8.2.1. BASIC DATA RATE GFSK MODULATION

RESTRICTED BANDEDGE (LOW CHANNEL, HORIZONTAL)

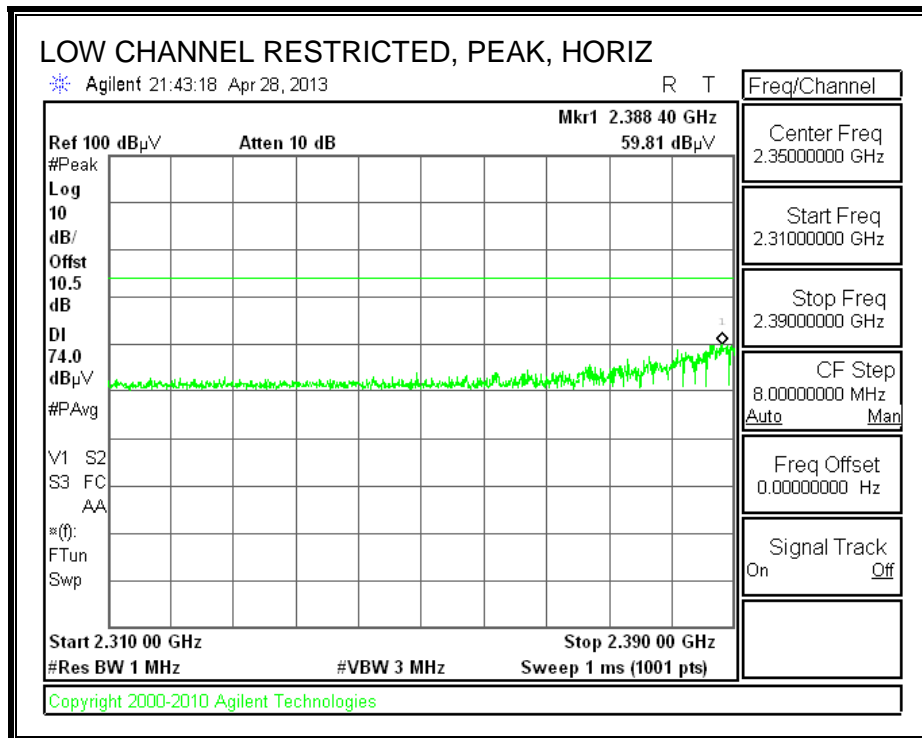

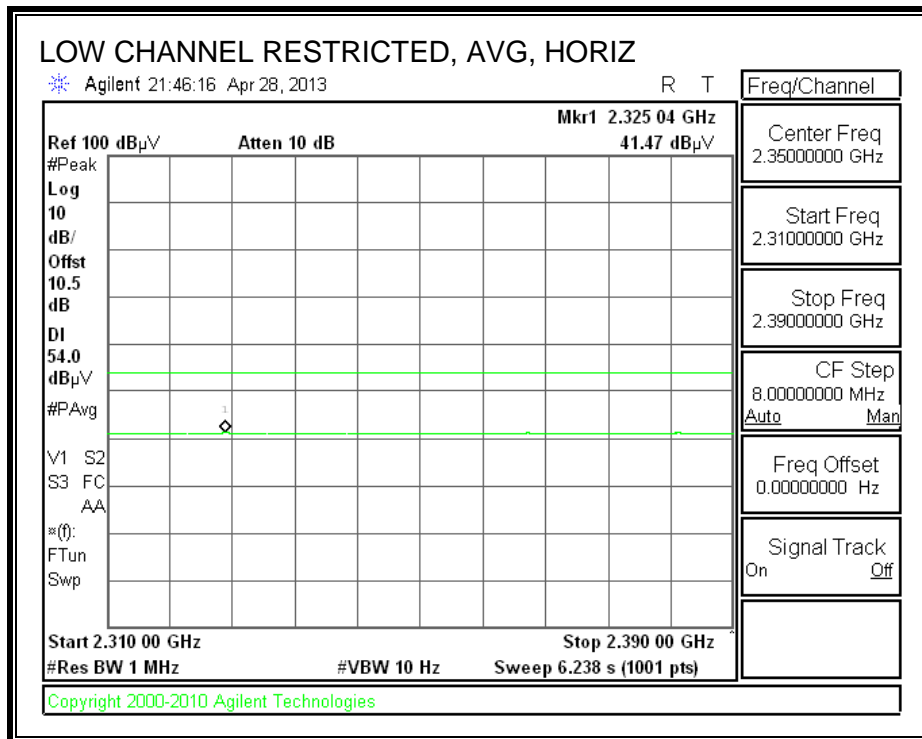

RESTRICTED BANDEDGE (LOW CHANNEL, VERTICAL)

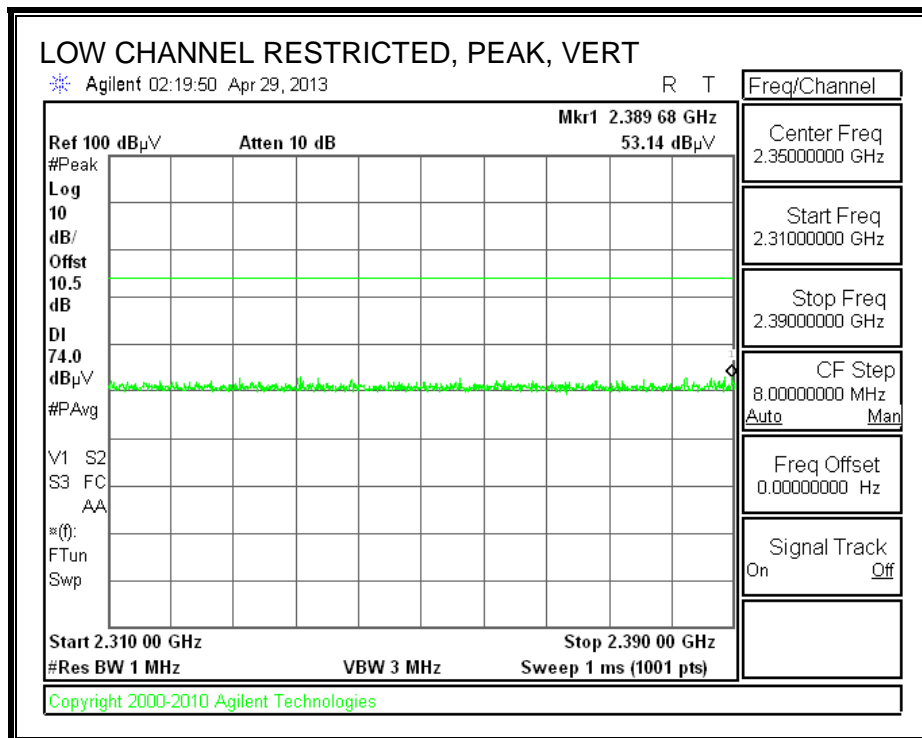

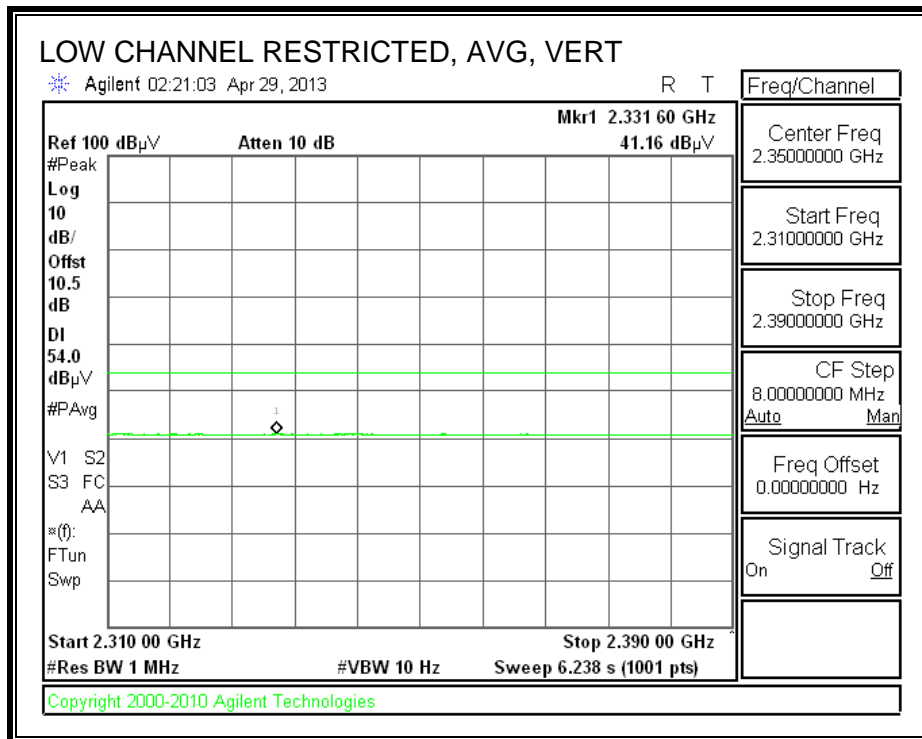

RESTRICTED BANDEDGE (HIGH CHANNEL, HORIZONTAL)

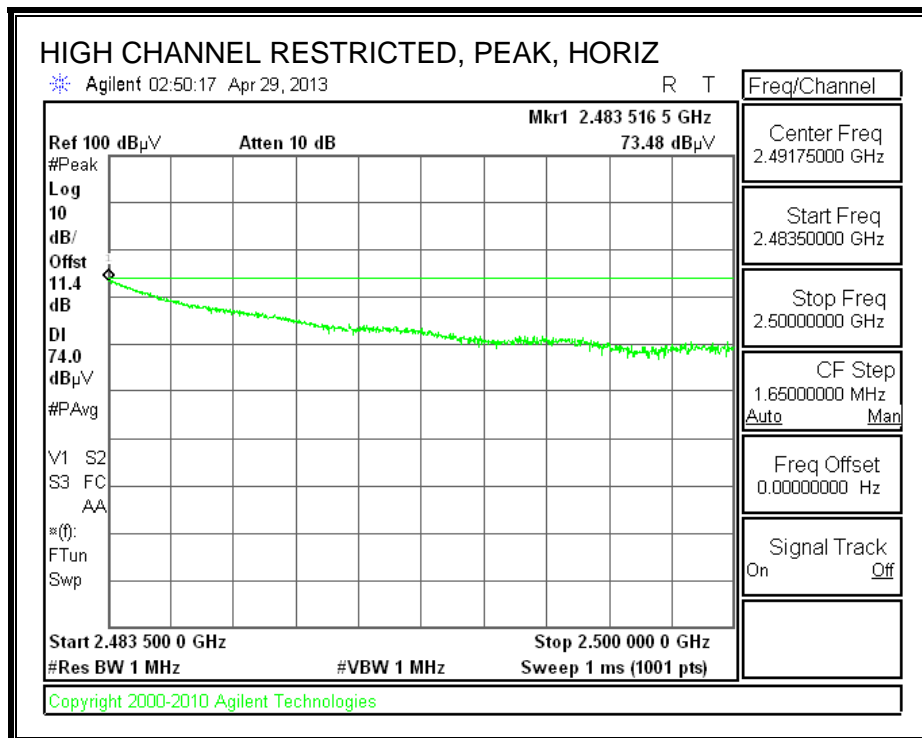

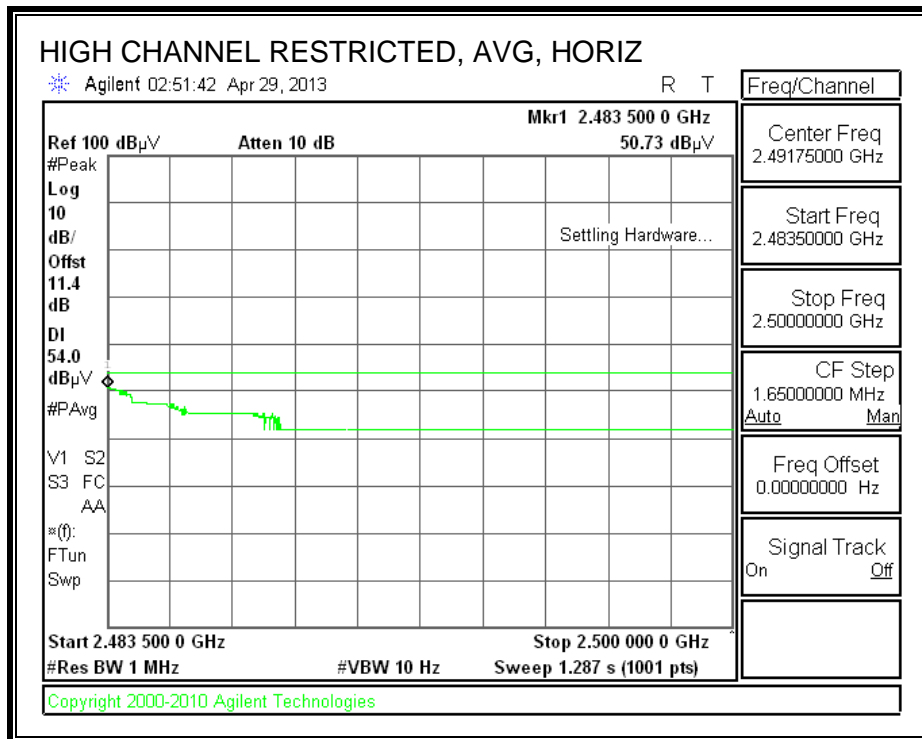

RESTRICTED BANDEDGE (HIGH CHANNEL, VERTICAL)

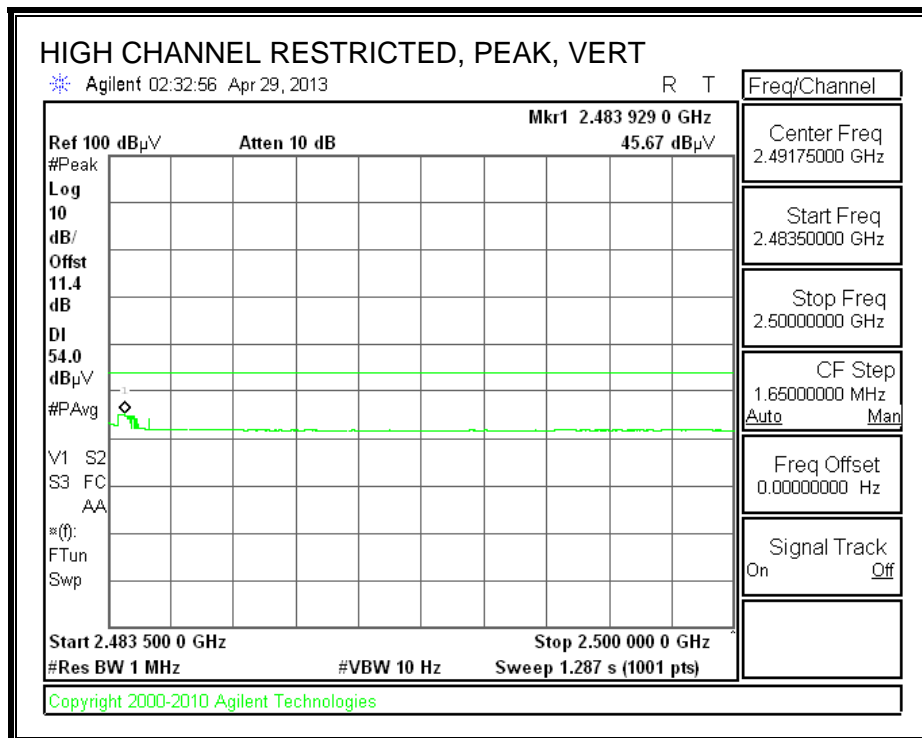

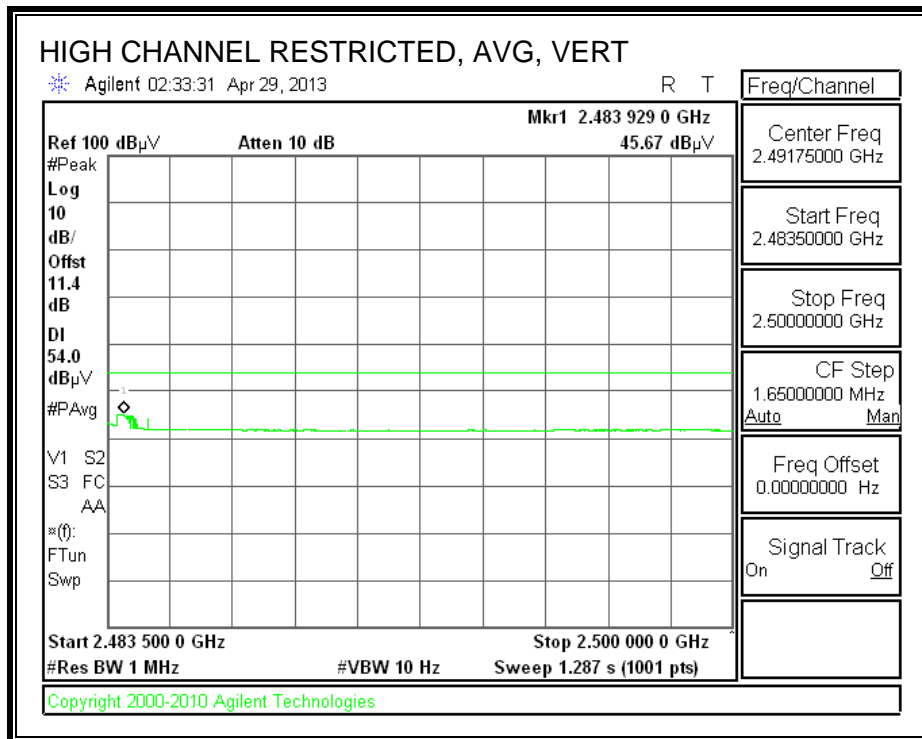

HARMONICS AND SPURIOUS EMISSIONS

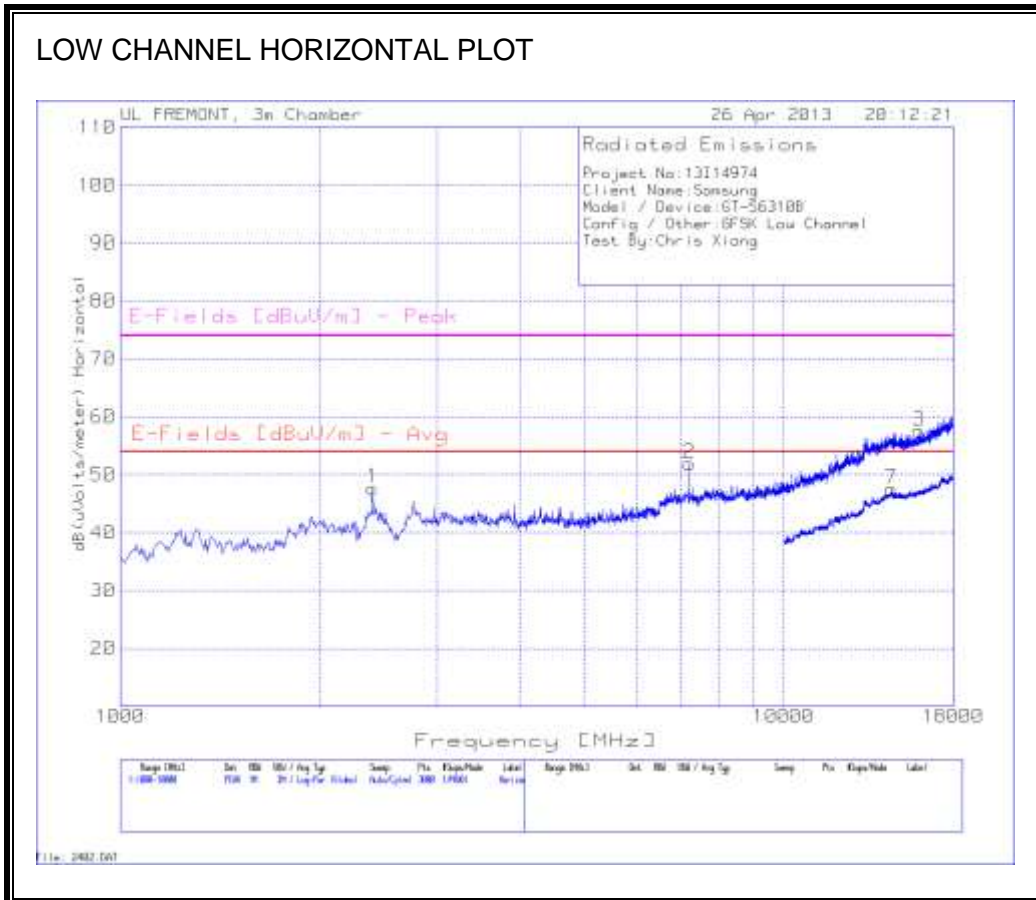

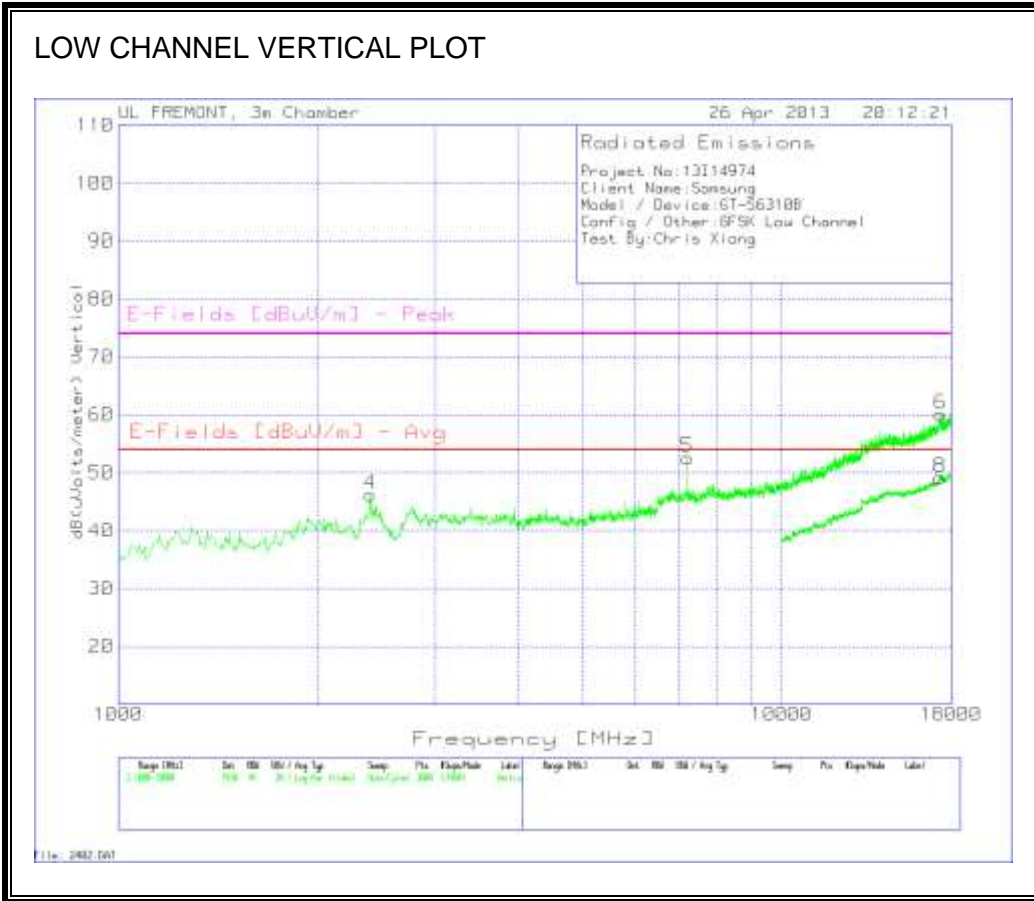

Low Channel

Project No: 13114974
 Client Name: Samsung
 Model / Device: GT-S6310B
 Config / Other: GFSK Low Channel
 Test By: Chris Xiong

Marker No.	Test Frequency (MHz)	Meter Reading (dBμV)	Detector	T119 Ant Factor [dB/m]	T34 Preamp/ Cable Loss [dB]	T160 BRF [dB]	dB(uVolts /meter)	E-Fields [dBuV/m] - Avg	Margin (dB)	E-Fields [dBuV/m] - Peak	Margin (dB)
Horizontal 1000 - 18000MHz											
1	2398.734	44.32	PK	32.1	-29.7	0.9	47.62	53.97	-6.35	74	-26.38
2	7206.529	42.01	PK2	35.6	-23.1	0.3	54.81	53.97	0.84	74	-19.19
2	7206.529	36.61	MAv2	35.6	-23.1	0.3	49.41	53.97	-4.56	74	-24.59
3	16006.662	32.97	PK	40.5	-16.2	0.3	57.57	53.97	3.6	74	-16.43
Vertical 1000 - 18000MHz											
4	2398.734	42.98	PK	32.1	-29.7	0.9	46.28	53.97	-7.69	74	-27.72
5	7206.529	42.12	PK2	35.6	-23.1	0.3	54.92	53.97	0.95	74	-19.08
5	7206.529	36.68	MAv1	35.6	-23.1	0.3	49.48	53.97	-4.49	74	-24.52
6	17354.43	32.6	PK	41.3	-14.3	0.5	60.1	53.97	6.13	74	-13.9
Horizontal 10000 - 18000MHz											
7	14525.737	23.52	PK	39.6	-16	0.4	47.52	53.97	-6.45	74	-26.48
Vertical 10000 - 18000MHz											
8	17320.34	21.56	PK	41.3	-14.3	0.6	49.16	53.97	-4.81	74	-24.84

PK - Peak detector
 PK2 - KDB558074 v02 10.2.3.2/8.1.1 Method: Maximum Peak
 MAv2 - KDB558074 v02 10.2.3.3/8.2.2 Option 2 Slow Sweep RMS Average
 Av - Average detector

MID CHANNEL HORIZONTAL PLOT

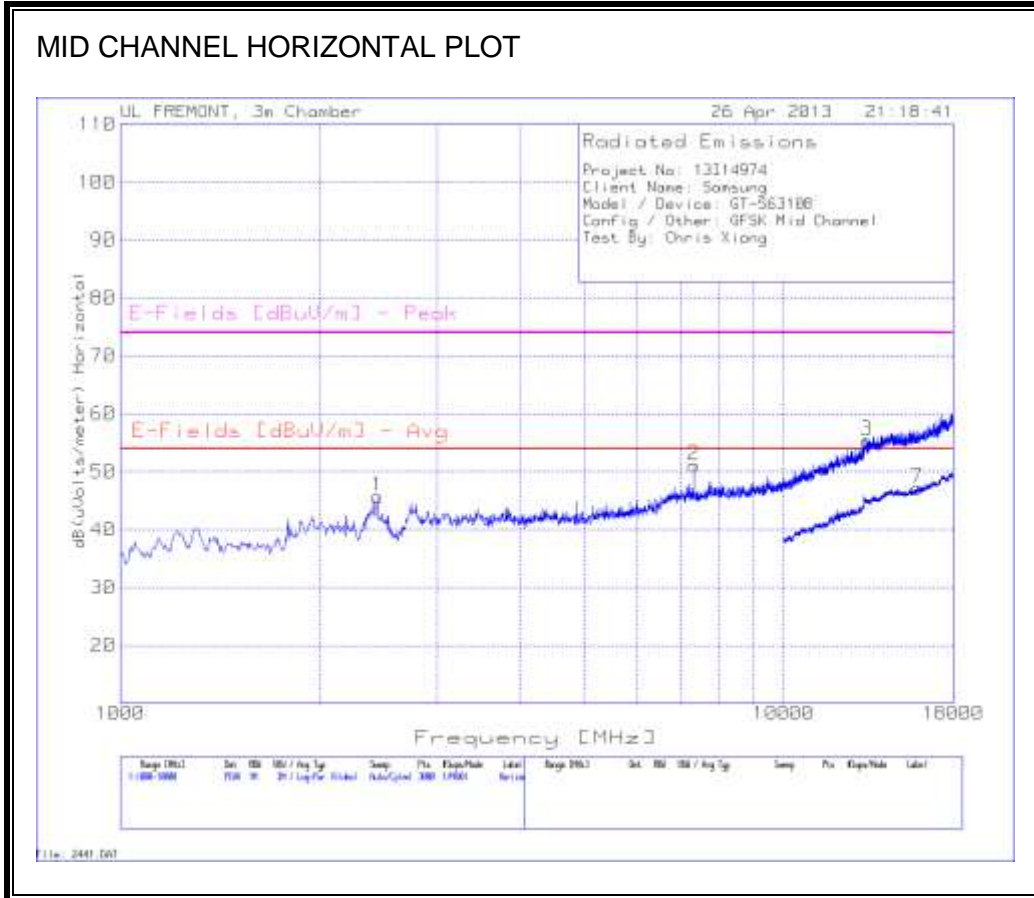

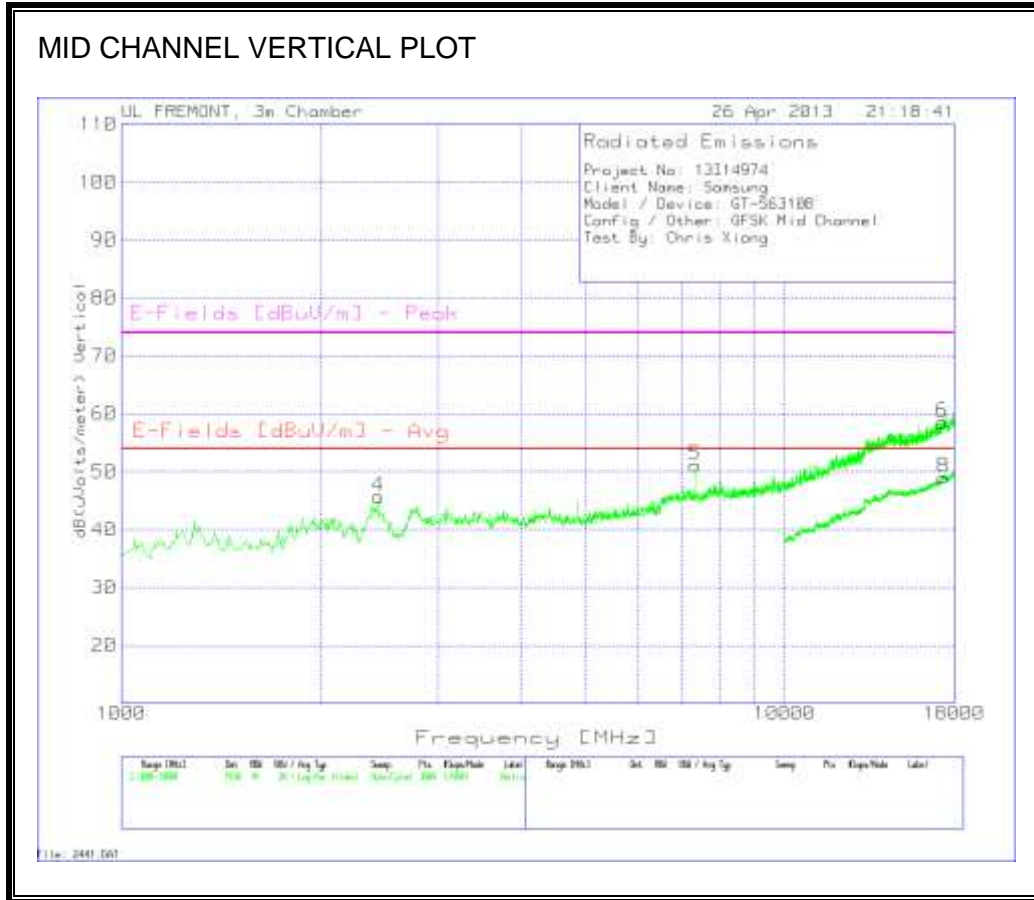

Mid Channel											
Project No: 13114974											
Client Name: Samsung											
Model / Device: GT-S6310B											
Config / Other: GFSK Mid Channel											
Test By: Chris Xiong											
Marker No.	Test Frequency (MHz)	Meter Reading (dBµV)	Detector	T119 Ant Factor [dB/m]	T34 Preamp/ Cable Loss [dB]	T160 BRF [dB]	dB(uVolts /meter)	E-Fields [dBuV/m] Avg	Margin (dB)	E-Fields [dBuV/m] Peak	Margin (dB)
Horizontal 1000 - 18000MHz											
1	2438.374	42.18	PK	32.2	-29.6	0.9	45.68	53.97	-8.29	74	-28.32
2	7325.45	40.02	PK2	35.6	-23	0.2	52.82	53.97	-1.15	74	-21.18
2	7325.45	33.62	MAv2	35.6	-23	0.2	46.42	53.97	-7.55	74	-27.58
3	13328.115	32.53	PK	39.2	-16.7	0.3	55.33	53.97	1.36	74	-18.67
Vertical 1000 - 18000MHz											
4	2438.374	42.24	PK	32.2	-29.6	0.9	45.74	53.97	-8.23	74	-28.26
5	7325.45	43.28	PK2	35.6	-23	0.2	56.08	53.97	2.11	74	-17.92
5	7325.45	38.16	MAv2	35.6	-23	0.2	50.96	53.97	-3.01	74	-23.04
6	17275.15	31.12	PK	41.2	-14.3	0.5	58.52	53.97	4.55	74	-15.48
Horizontal 10000 - 18000MHz											
7	15893.053	22.64	PK	40.5	-16.3	0.3	47.14	53.97	-6.83	74	-26.86
Vertical 10000 - 18000MHz											
8	17364.318	21.56	PK	41.3	-14.3	0.5	49.06	53.97	-4.91	74	-24.94
PK - Peak detector											
PK2 - KDB558074 v02 10.2.3.2/8.1.1 Method: Maximum Peak											
MAv2 - KDB558074 v02 10.2.3.3/8.2.2 Option 2 Slow Sweep RMS Average											
Av - Average detector											

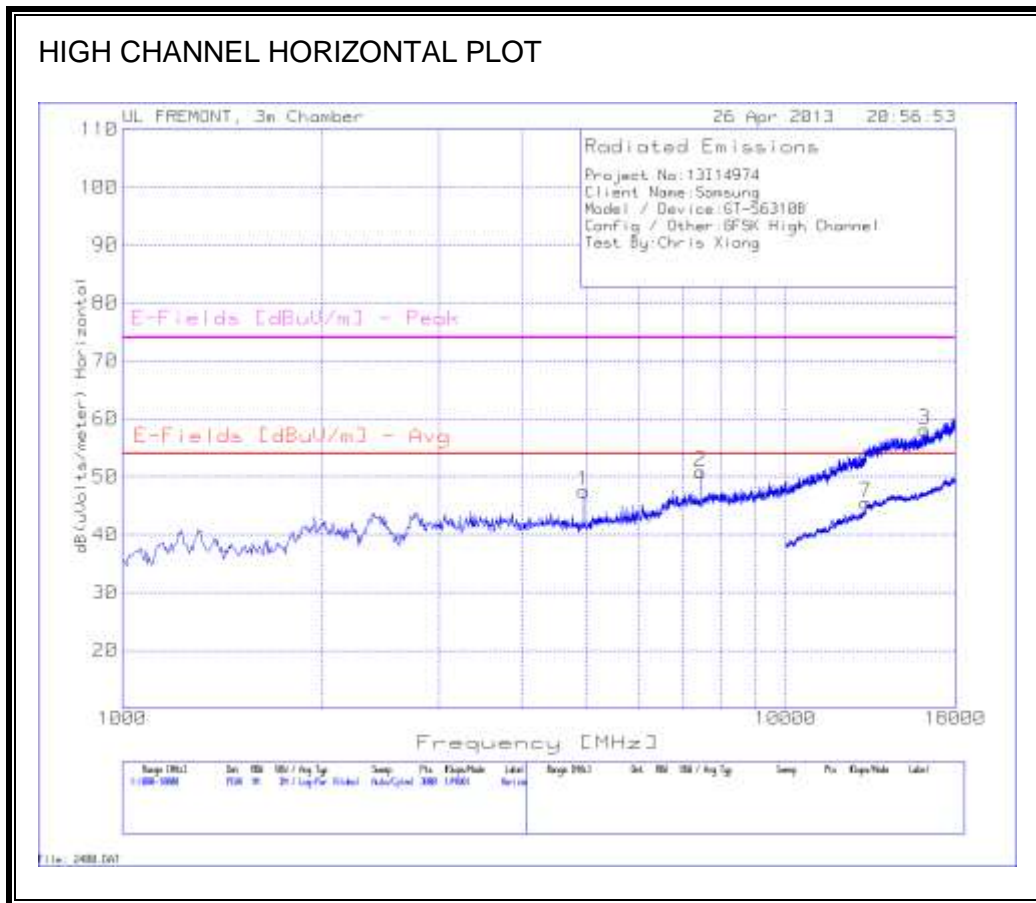

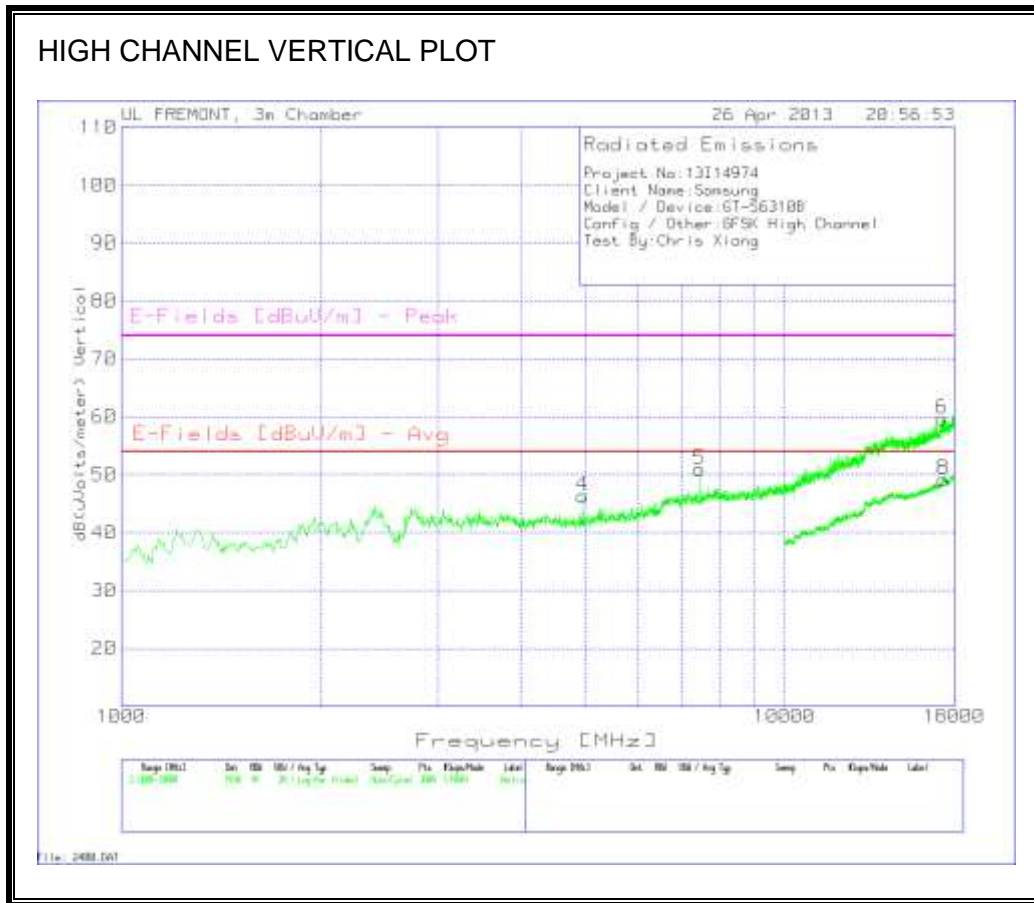

High Channel											
Project No: 13114974											
Client Name: Samsung											
Model / Device: GT-S6310B											
Config / Other: GFSK High Channel											
Test By: Chris Xiong											
Marker No.	Test Frequency (MHz)	Meter Reading (dBµV)	Detector	T119 Ant Factor [dB/m]	T34 Preamp/ Cable Loss [dB]	T160 BRF [dB]	dB(uVolts /meter)	E-Fields [dBuV/m] - Avg	Margin (dB)	E-Fields [dBuV/m] - Peak	Margin (dB)
Horizontal 1000 - 18000MHz											
1	4958.361	38.28	PK	34	-25	0.2	47.48	53.97	-6.49	74	-26.52
2	7438.708	38.26	PK2	35.7	-23	0.3	51.26	53.97	-2.71	74	-22.74
2	7438.708	31.16	MAv2	35.7	-23	0.3	44.16	53.97	-9.81	74	-29.84
3	16199.201	33.33	PK	40.6	-16.2	0.4	58.13	53.97	4.16	74	-15.87
Vertical 1000 - 18000MHz											
4	4958.361	37.09	PK	34	-25	0.2	46.29	53.97	-7.68	74	-27.71
5	7438.708	42.97	PK2	35.7	-23	0.3	55.97	53.97	2	74	-18.03
5	7438.708	37.95	MAv2	35.7	-23	0.3	50.95	53.97	-3.02	74	-23.05
6	17263.824	32.27	PK	41.2	-14.4	0.6	59.67	53.97	5.7	74	-14.33
Horizontal 10000 - 18000MHz											
7	13198.401	22.91	PK	39	-16.8	0.4	45.51	53.97	-8.46	74	-28.49
Vertical 10000 - 18000MHz											
8	17372.314	21.66	PK	41.3	-14.3	0.5	49.16	53.97	-4.81	74	-24.84
PK - Peak detector											
PK2 - KDB558074 v02 10.2.3.2/8.1.1 Method: Maximum Peak											
MAv2 - KDB558074 v02 10.2.3.3/8.2.2 Option 2 Slow Sweep RMS Average											
Av - Average detector											

8.2.2. ENHANCED DATA RATE 8PSK MODULATION

RESTRICTED BANDEDGE (LOW CHANNEL, HORIZONTAL)

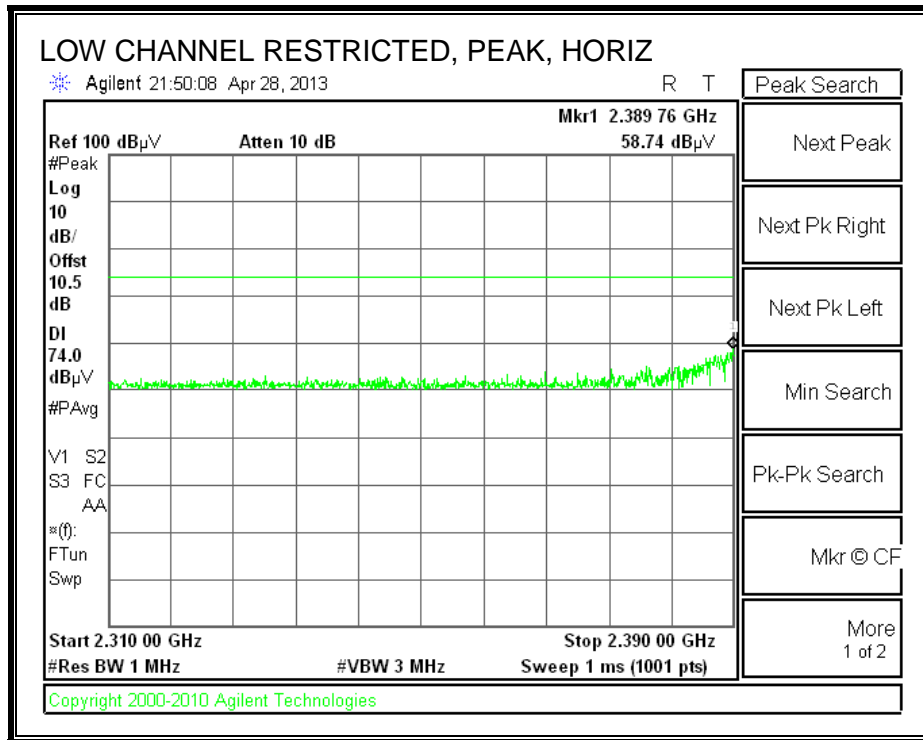

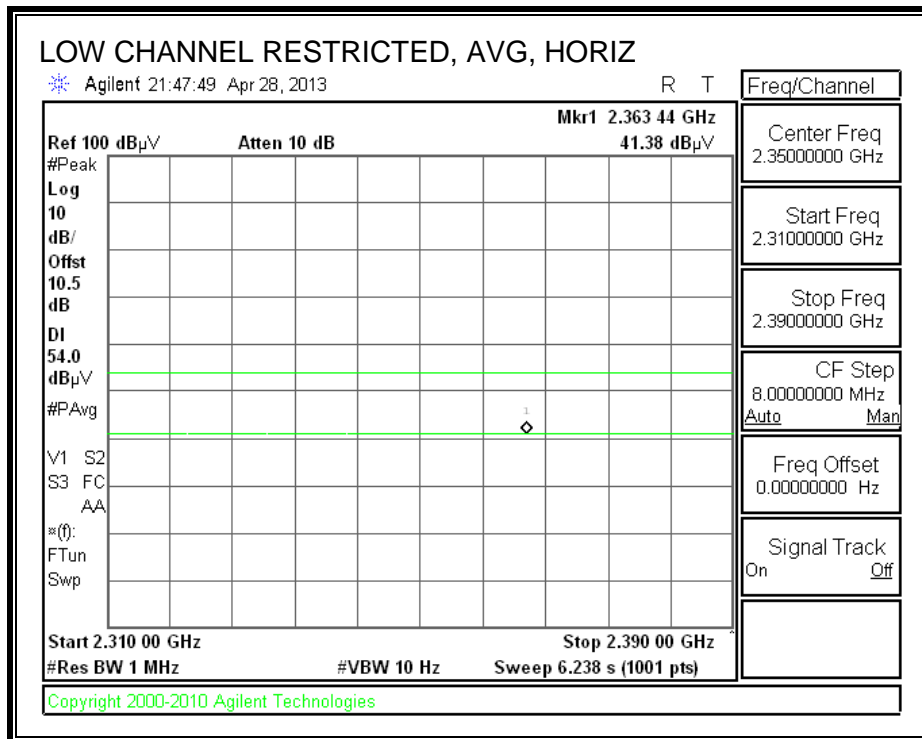

RESTRICTED BANDEDGE (LOW CHANNEL, VERTICAL)

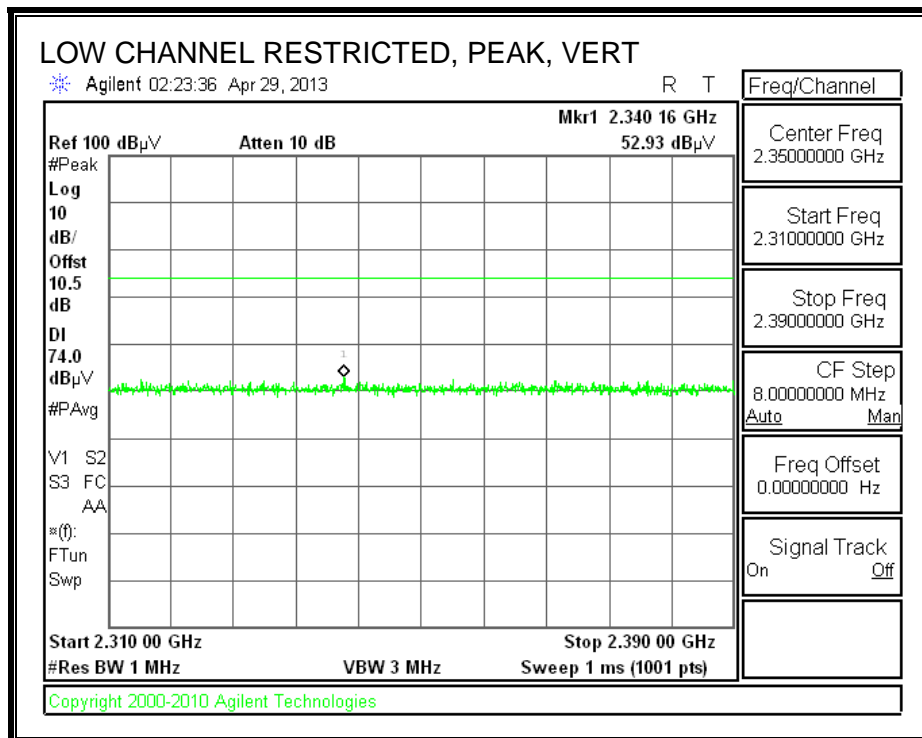

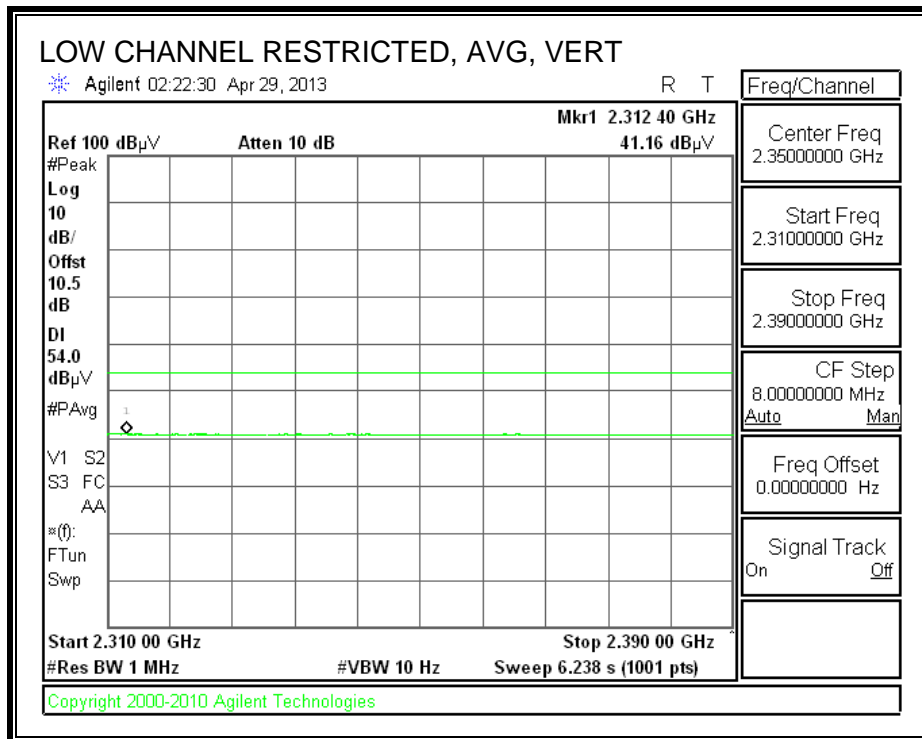

RESTRICTED BANDEDGE (HIGH CHANNEL, HORIZONTAL)

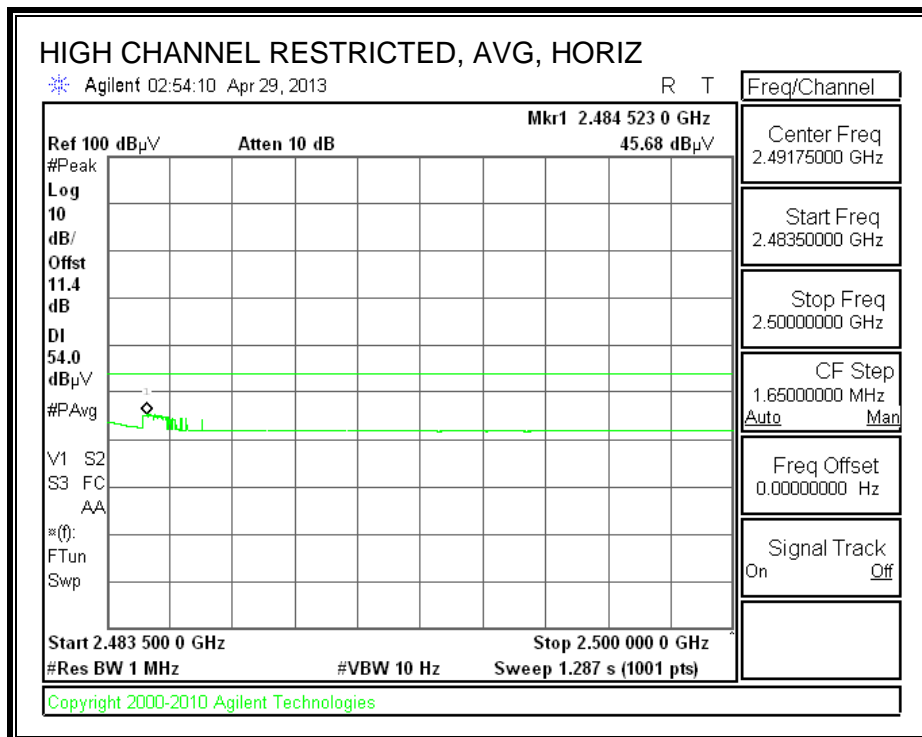
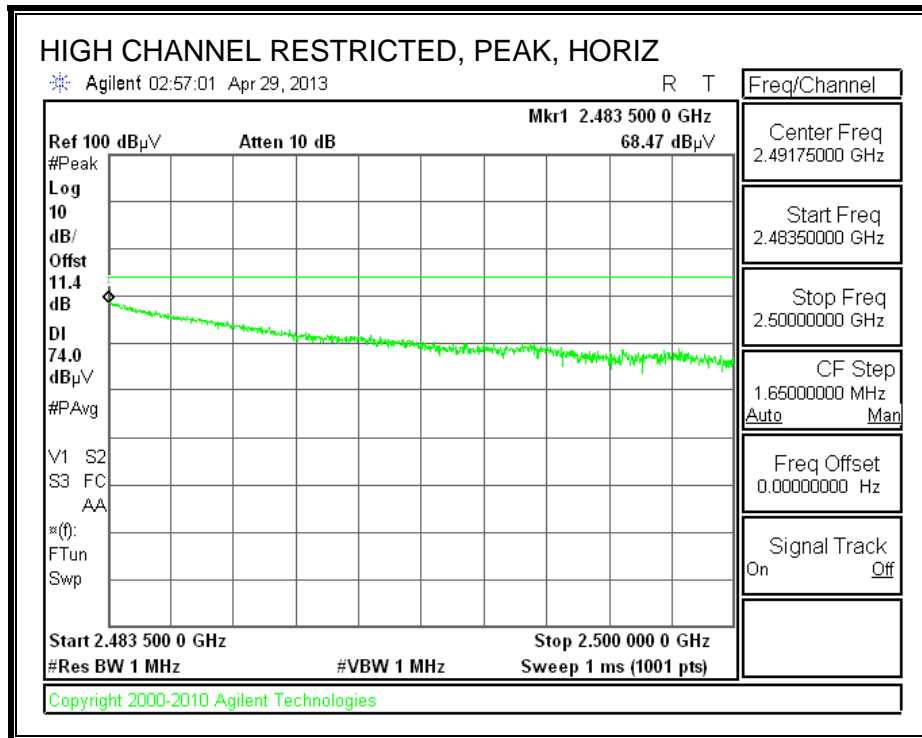

RESTRICTED BANDEDGE (HIGH CHANNEL, VERTICAL)

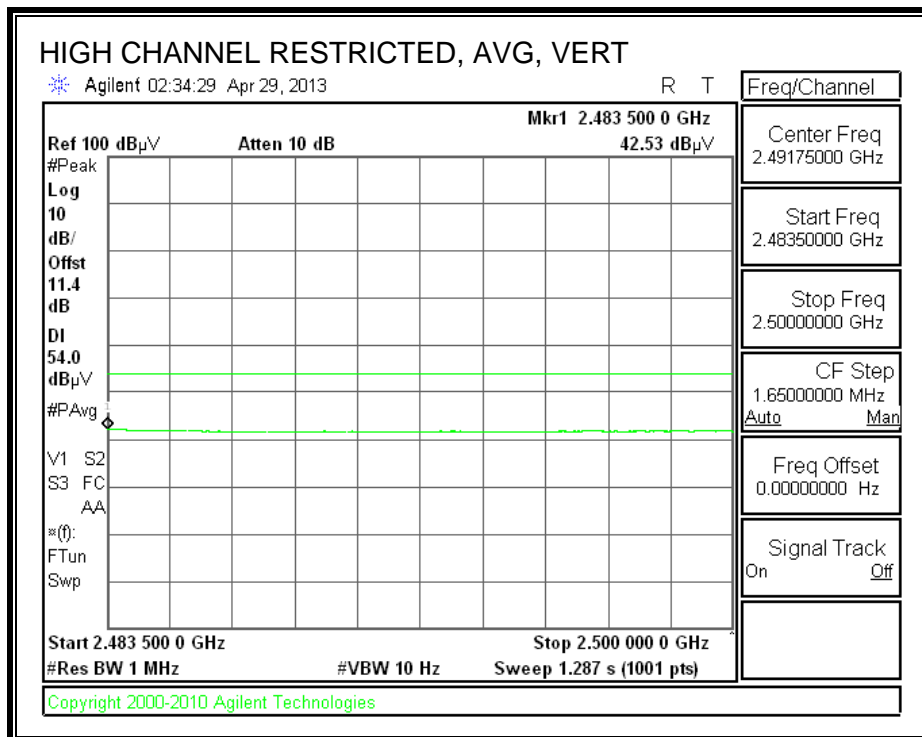
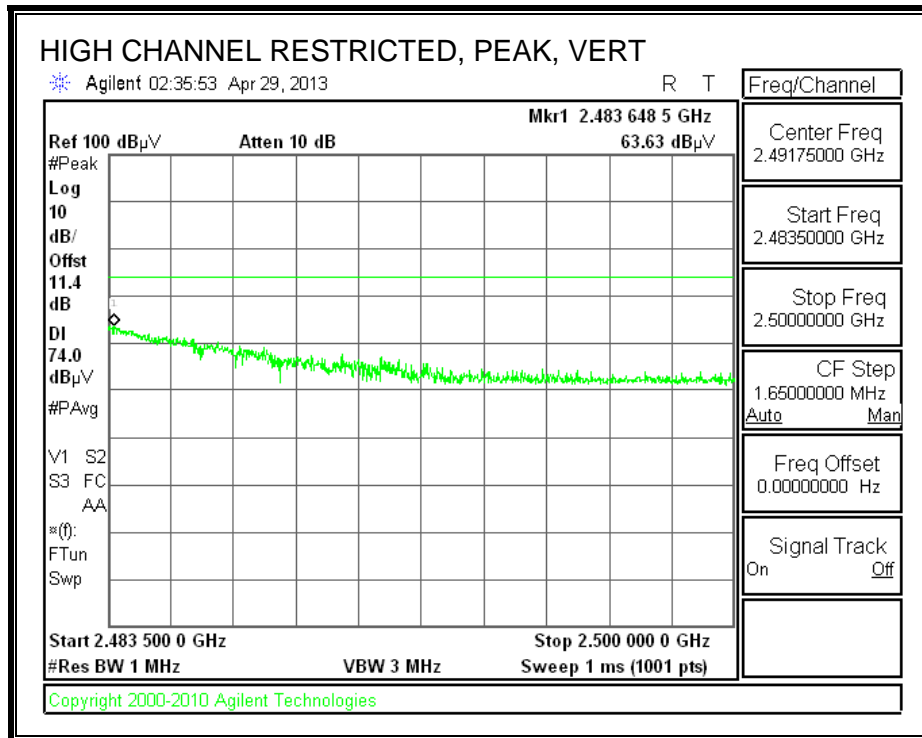

HARMONICS AND SPURIOUS EMISSIONS

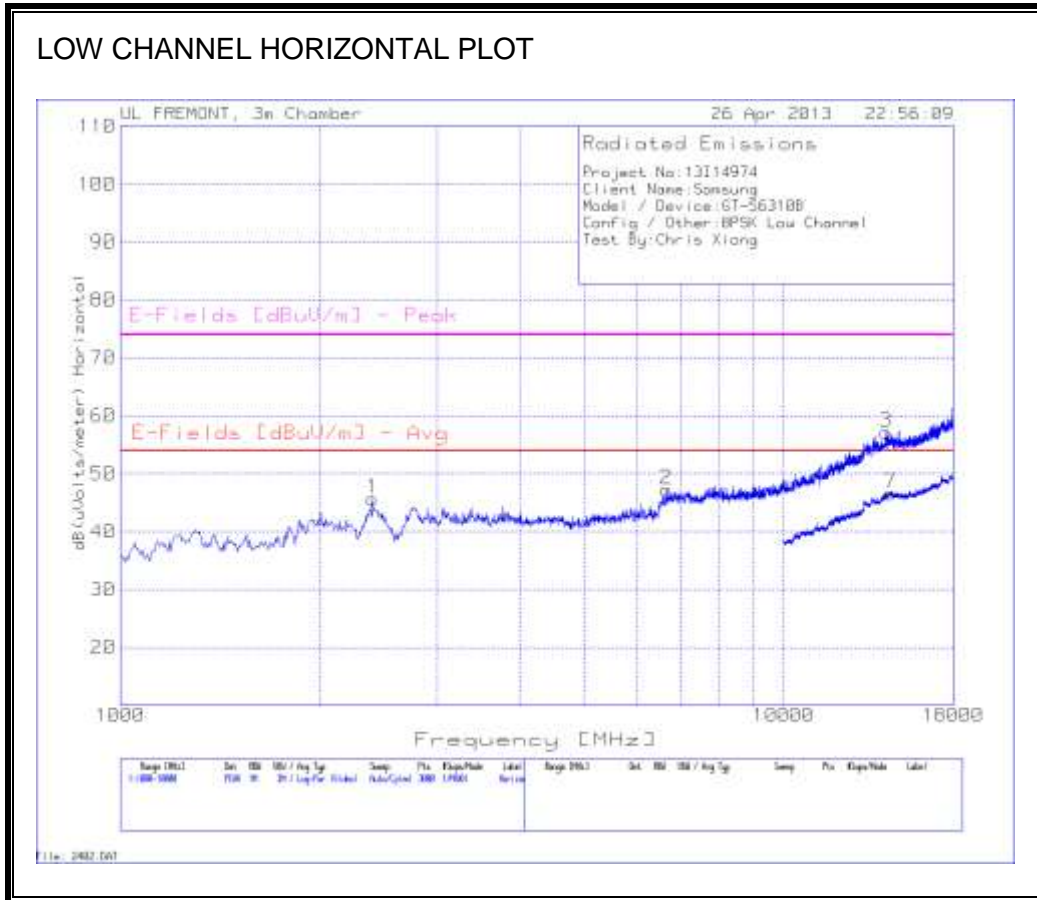

LOW CHANNEL VERTICAL PLOT

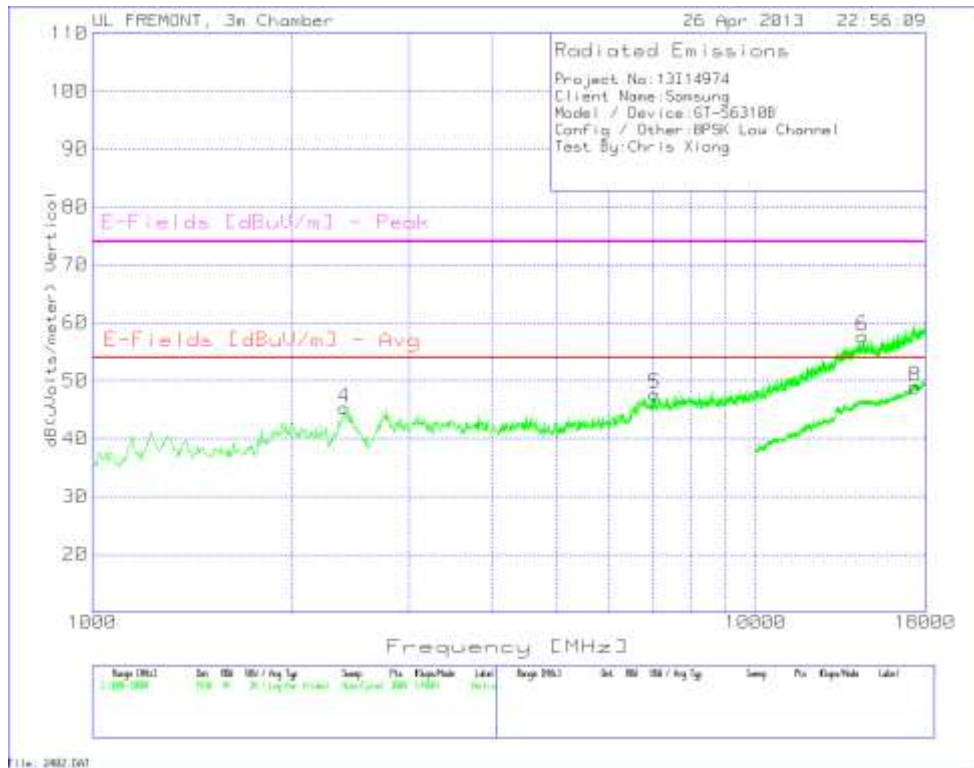

Low Channel												
Project No:13114974												
Client Name:Samsung												
Model / Device:GT-S6310B												
Config / Other:8PSK Low Channel												
Test By:Chris Xiong												
Marker No.	Test Frequency	Meter Reading	Detector	T119 Ant Factor [dB/m]	T34 Preamp/ Cable Loss [dB]	T160 BRF [dB]	dB(uVolts/ meter)	E-Fields [dBuV/m] Avg	Margin (dB)	E-Fields [dBuV/m] - Peak	Margin (dB)	
Horizontal 1000 - 18000MHz												
1	2398.734	42.42	PK	32.1	-29.7	0.9	45.72	53.97	-8.25	74	-28.28	
2	6651.566	34.74	PK	35.6	-23.4	0.3	47.24	53.97	-6.73	74	-26.76	
3	14251.166	33.34	PK	39.2	-15.8	0.4	57.14	53.97	3.17	74	-16.86	
Vertical 1000 - 18000MHz												
4	2398.734	41.98	PK	32.1	-29.7	0.9	45.28	53.97	-8.69	74	-28.72	
5	7047.968	34.94	PK	35.6	-23.2	0.3	47.64	53.97	-6.33	74	-26.36	
6	14489.007	33.66	PK	39.6	-16	0.4	57.66	53.97	3.69	74	-16.34	
Horizontal 10000 - 18000MHz												
7	14481.759	22.55	PK	39.6	-15.9	0.4	46.65	53.97	-7.32	74	-27.35	
Vertical 10000 - 18000MHz												
8	17412.294	21.48	PK	41.3	-14.3	0.5	48.98	53.97	-4.99	74	-25.02	
PK - Peak detector												
Av - Average detector												

MID CHANNEL HORIZONTAL PLOT

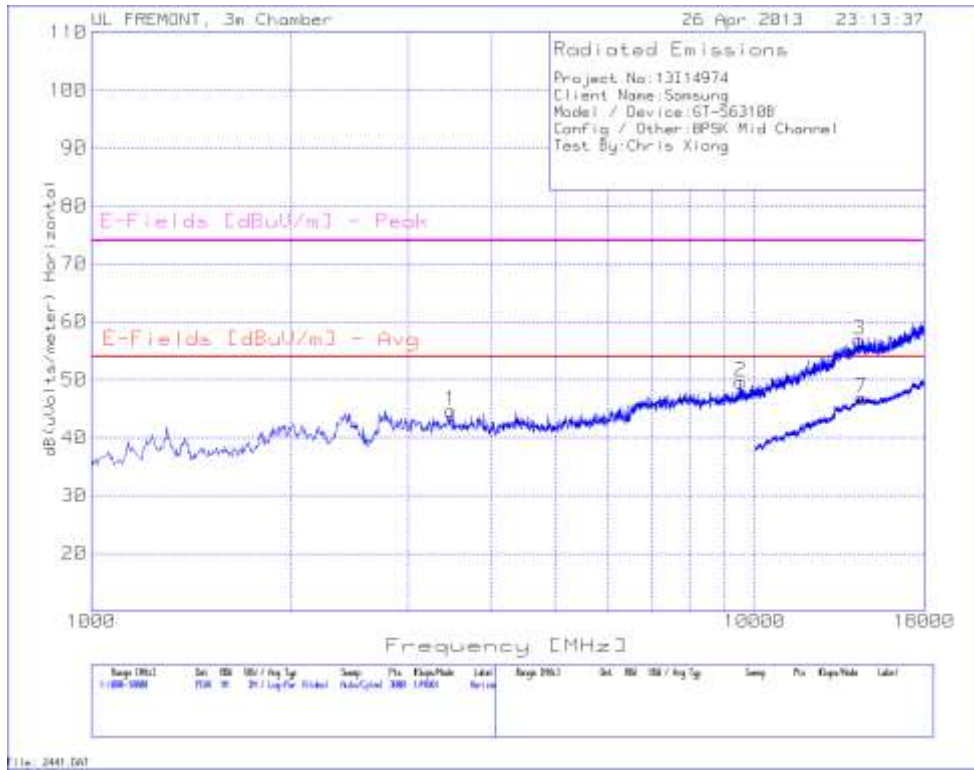

MID CHANNEL VERTICAL PLOT

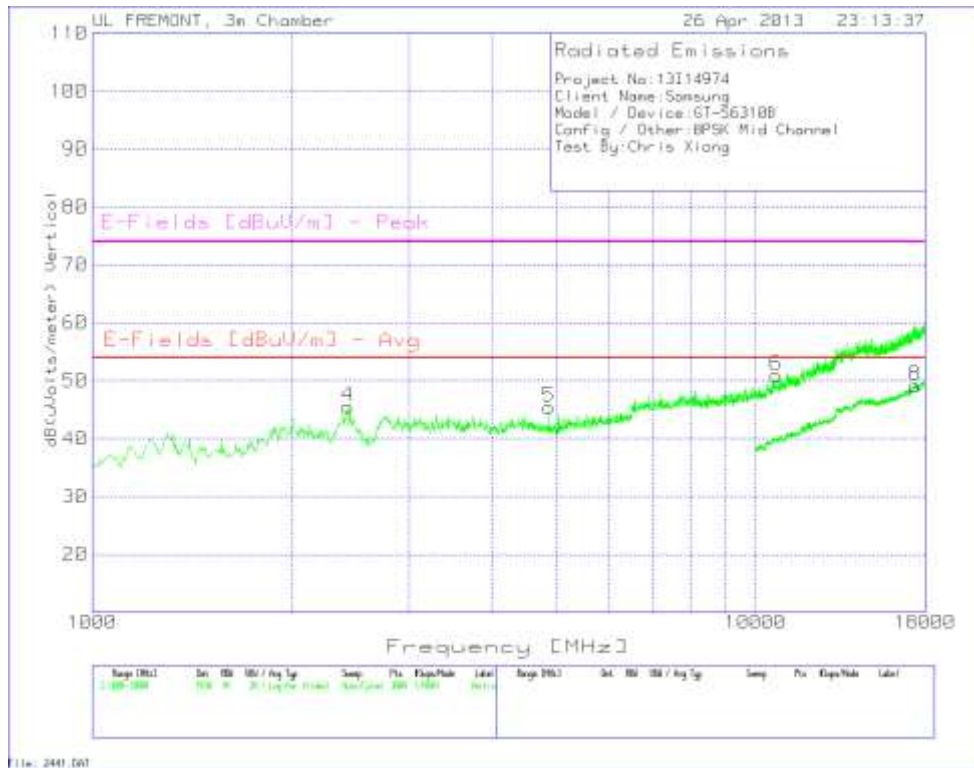

Mid Channel

Project No:13114974
 Client Name:Samsung
 Model / Device:GT-S6310B
 Config / Other:8PSK Mid Channel
 Test By:Chris Xiong

Marker No.	Test Frequency	Meter Reading	Detector	T119 Ant Factor [dB/m]	T34 Preamp/ Cable Loss [dB]	T160 BRF [dB]	dB(uVolts/ meter)	E-Fields [dBuV/m] - Avg	Margin (dB)	E-Fields [dBuV/m] - Peak	Margin (dB)
Horizontal 1000 - 18000MHz											
1	3480.346	38.48	PK	33	-27.3	0.4	44.58	53.97	-9.39	74	-29.42
2	9522.652	34.47	PK	36.6	-21.8	0.4	49.67	53.97	-4.3	74	-24.33
3	14358.761	33.01	PK	39.4	-15.8	0.3	56.91	53.97	2.94	74	-17.09
Vertical 1000 - 18000MHz											
4	2427.049	42.1	PK	32.2	-29.7	0.9	45.5	53.97	-8.47	74	-28.5
5	4879.081	36.4	PK	34	-25.2	0.2	45.4	53.97	-8.57	74	-28.6
6	10734.51	32.83	PK	37.9	-20.3	0.6	51.03	53.97	-2.94	74	-22.97
Horizontal 10000 - 18000MHz											
7	14485.757	22.9	PK	39.6	-16	0.4	46.9	53.97	-7.07	74	-27.1
Vertical 10000 - 18000MHz											
8	17416.292	21.58	PK	41.3	-14.3	0.6	49.18	53.97	-4.79	74	-24.82

PK - Peak detector
 Av - Average detector

HIGH CHANNEL HORIZONTAL PLOT

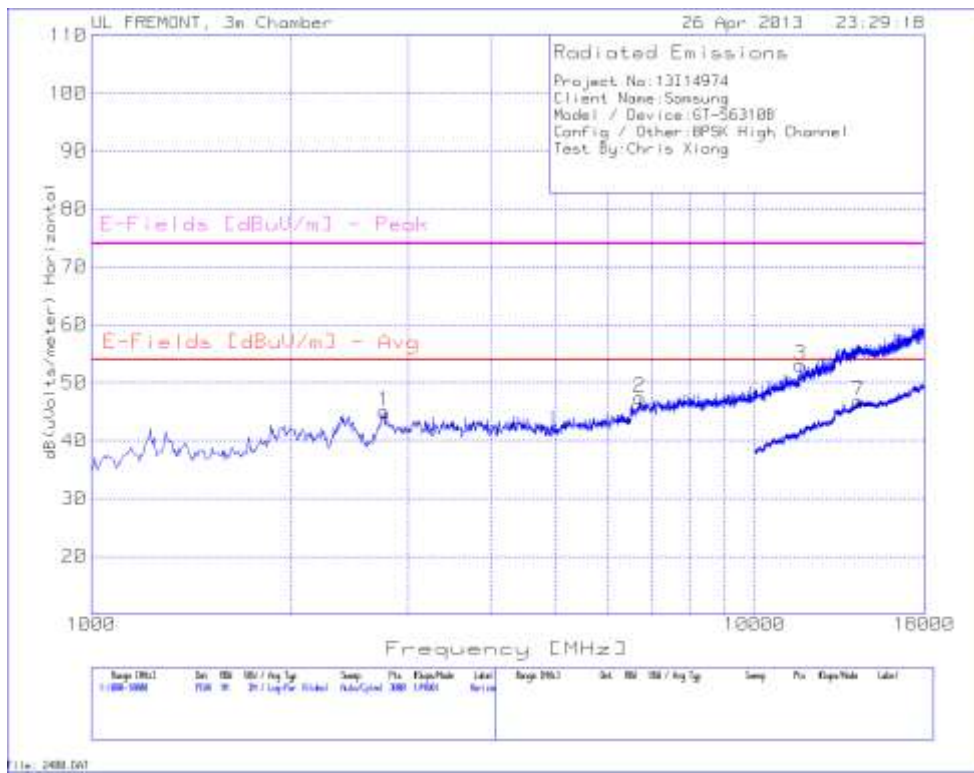

HIGH CHANNEL VERTICAL PLOT

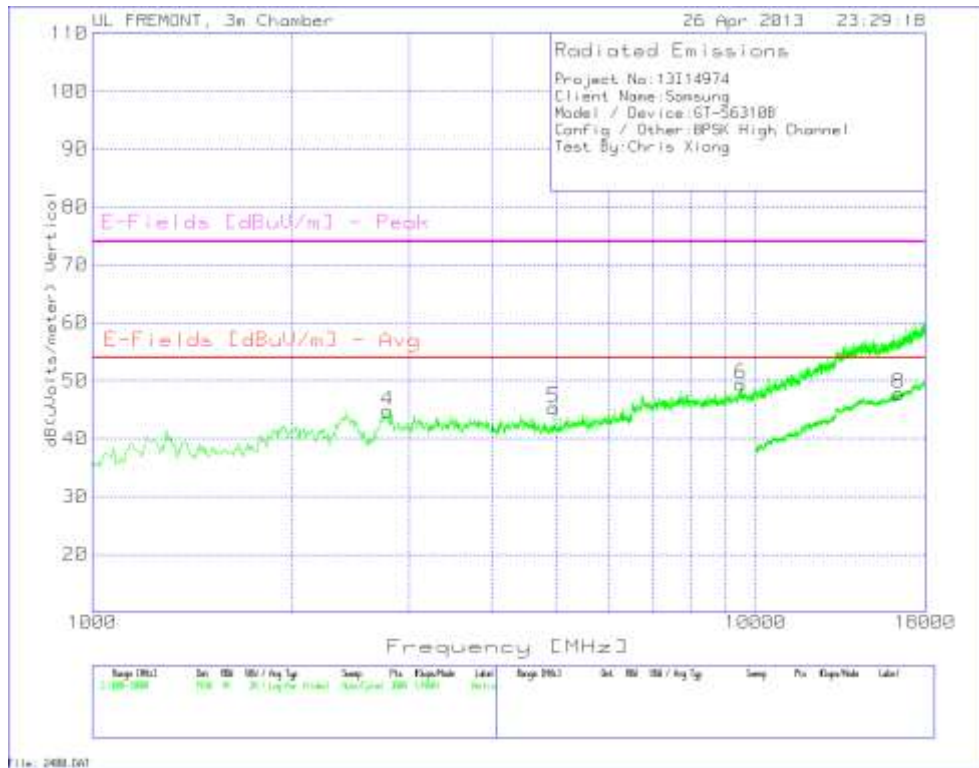

High Channel											
Project No:13I14974											
Client Name:Samsung											
Model / Device:GT-S6310B											
Config / Other:8PSK High Channel											
Test By:Chris Xiong											
Marker No.	Test Frequency	Meter Reading	Detector	T119 Ant Factor [dB/m]	T34 Preamp/ Cable Loss [dB]	T160 BRF [dB]	dB(uVolts/ meter)	E-Fields [dBuV/m] - Avg	Margin (dB)	E-Fields [dBuV/m] - Peak	Margin (dB)
Horizontal 1000 - 18000MHz											
1	2761.159	40.32	PK	32.7	-28.9	0.9	45.02	53.97	-8.95	74	-28.98
2	6702.532	34.97	PK	35.6	-23.4	0.3	47.47	53.97	-6.5	74	-26.53
3	11714.191	33.02	PK	38.7	-19.2	0.6	53.12	53.97	-0.85	74	-20.88
Vertical 1000 - 18000MHz											
4	2783.811	40.05	PK	32.7	-28.9	0.9	44.75	53.97	-9.22	74	-29.25
5	4958.361	36.04	PK	34	-25	0.2	45.24	53.97	-8.73	74	-28.76
6	9511.326	34.15	PK	36.6	-21.8	0.5	49.45	53.97	-4.52	74	-24.55
Horizontal 10000 - 18000MHz											
7	14349.825	22.72	PK	39.4	-15.8	0.4	46.72	53.97	-7.25	74	-27.28
Vertical 10000 - 18000MHz											
8	16420.79	22.43	PK	41	-16	0.4	47.83	53.97	-6.14	74	-26.17
PK - Peak detector											
Av - Average detector											

8.3. WORST-CASE BELOW 1 GHz

SPURIOUS EMISSIONS 30 TO 1000 MHz (WORST-CASE CONFIGURATION, HORIZONTAL)

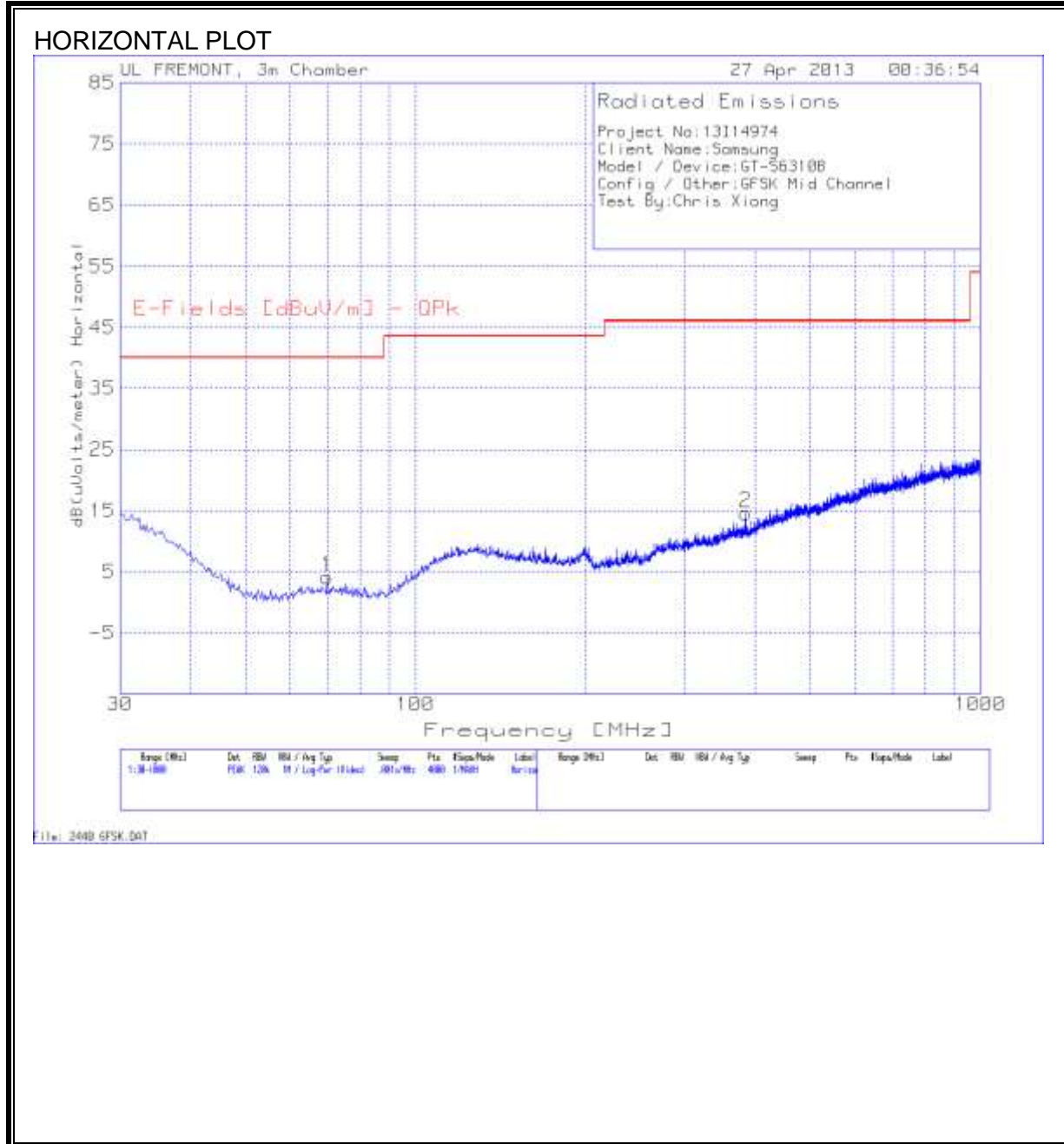

SPURIOUS EMISSIONS 30 TO 1000 MHz (WORST-CASE CONFIGURATION, VERTICAL)

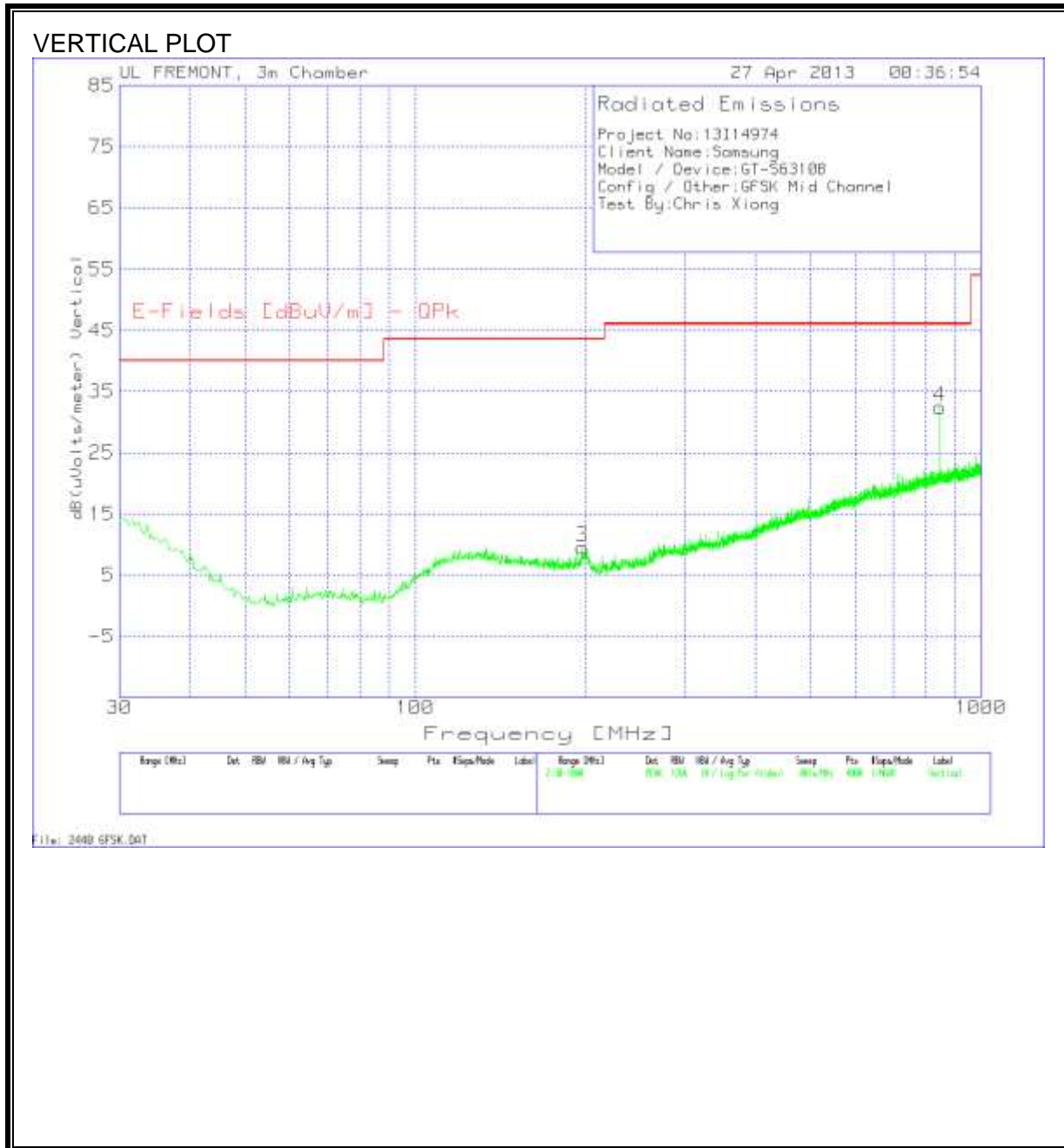

VERTICAL AND HORIZONTAL DATA

Project No:13I14974										
Client Name:Samsung										
Model / Device:GT-S6310B										
Config / Other:GFSK Mid Channel										
Test By:Chris Xiong										
Marker No.	Test Frequency	Meter Reading	Detector	T130 Ant Factor [dB/m]	T64 preamp/cable loss [dB]	dB(uVolts/ meter)	E-Fields [dBUV/m] - QPk	Margin (dB)	Height [cm]	Polarity
Horizontal 30 - 1000MHz										
1	69.7402	23.35	PK	8.1	-27.3	4.15	40	-35.85	99	Horz
2	384.027	24.8	PK	15.1	-25.3	14.6	46.02	-31.42	301	Horz
Vertical 30 - 1000MHz										
3	197.1996	23.42	PK	12.4	-26.2	9.62	43.52	-33.9	199	Vert
4	845.8856	33.36	PK	21.9	-22.8	32.46	46.02	-13.56	401	Vert
PK - Peak detector										
Av - Average detector										

9. AC POWER LINE CONDUCTED EMISSIONS

LIMITS

FCC §15.207 (a)

RSS-Gen 7.2.2

Frequency of Emission (MHz)	Conducted Limit (dBuV)	
	Quasi-peak	Average
0.15-0.5	66 to 56	56 to 46
0.5-5	56	46
5-30	60	50

*Decreases with the logarithm of the frequency.

TEST PROCEDURE

The EUT is placed on a non-conducting table 40 cm from the vertical ground plane and 80 cm above the horizontal ground plane. The EUT is configured in accordance with ANSI C63.4.

The receiver is set to a resolution bandwidth of 9 kHz. Peak detection is used unless otherwise noted as quasi-peak or average.

Line conducted data is recorded for both NEUTRAL and HOT lines.

RESULTS

6 WORST EMISSIONS

Project No:13i14974									
Client Name:Samsung Electronics									
Model/Device:GT-S6310B									
Test Volt/Freq:115VAC/60Hz									
Test By:M. Mekuria									
Test Frequency	Meter Reading	Detector	T24 IL L1.TXT (dB)	LC Cables 1&3.TXT (dB)	dB(uVolts)	CFR 47 Part 15 Class B QP	Margin	CFR 47 Part 15 Class B Avg	Margin
Line-L1 .15 - 30MHz									
0.1635	44.48	PK	0.1	0	44.58	65.3	-20.72	-	-
0.1635	28.43	Av	0.1	0	28.53	-	-	55.3	-26.77
1.878	50.62	PK	0.1	0.1	50.82	56	-5.18	-	-
1.878	35.64	Av	0.1	0.1	35.84	-	-	46	-10.16
20.112	49.03	PK	0.3	0.2	49.53	60	-10.47	-	-
20.112	30.57	Av	0.3	0.2	31.07	-	-	50	-18.93
Line-L2 .15 - 30MHz									
0.159	35.76	PK	0.1	0	35.86	65.5	-29.64	-	-
0.159	19.24	Av	0.1	0	19.34	-	-	55.5	-36.16
1.833	47	PK	0.1	0.1	47.2	56	-8.8	-	-
1.833	30.74	Av	0.1	0.1	30.94	-	-	46	-15.06
15.4815	42.14	PK	0.2	0.2	42.54	60	-17.46	-	-
15.4815	22.54	Av	0.2	0.2	22.94	-	-	50	-27.06
PK - Peak detector									
QP - Quasi-Peak detector									
Av - Average detector									

LINE 1 RESULTS

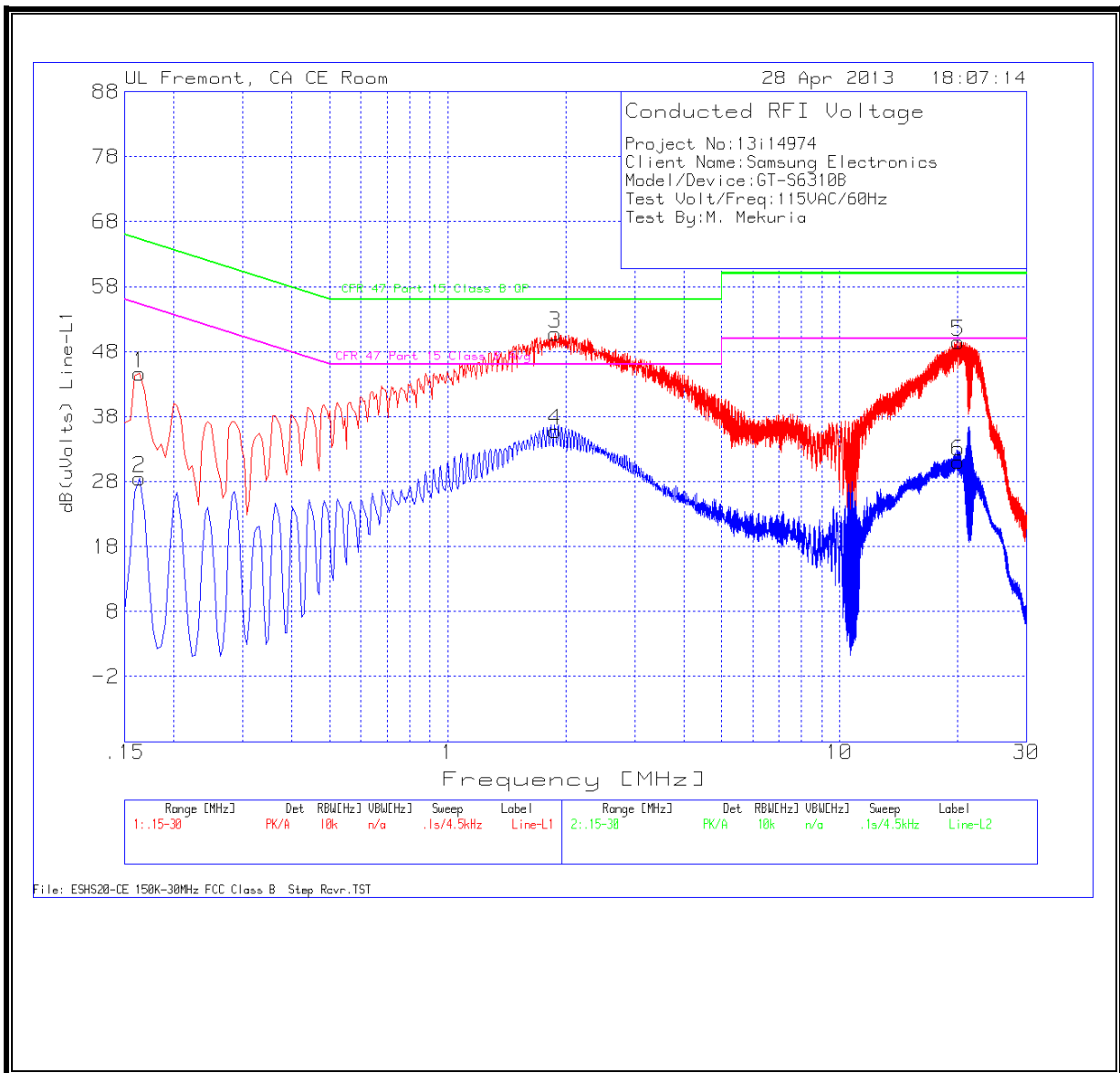

LINE 2 RESULTS

