



FCC TEST REPORT

Reference No. : G-45-2011-03440
Applicant : SAMSUNG ELECTRONICS Co., Ltd.
Equipment Under Test (EUT) :
Product Name : SAMSUNG Mobile Phone
Model Name : GT-S6102
Applied Standards : FCC Part 15 : 2009, Subpart B, Class B
ANSI C63.4 : 2003
CISPR 22 : 2006
Date of Receipt : December 13, 2011
Date of Test : December 28, 2011 ~ December 29, 2011
Date of Issue : January 02, 2012
Test Results : Complied

Tested by :	 ----- Jay Choi
Reviewed by :	 ----- Carl Lee

Remarks :

This report details the results of the testing carried out on one sample, the results contained in this test report do not relate to other samples of the same product. The manufacturer should ensure that all products in series production are in conformity with the product sample detailed in this report.

This report may only be reproduced and distributed in full. If the product in this report is used in any configuration other than that detailed in the report, the manufacturer must ensure the new system complies with all relevant standards. Any mention of SGS International Electrical Approvals or Testing done by SGS International Electrical Approvals in connection with distribution or use of the product described in this report must be approved by SGS International Electrical Approvals in writing.

Contents

1. General Information	3
1.1 Client Information	3
1.2 Test Laboratory	3
1.3 General Information of E.U.T.	3
1.4 Operating Modes and Conditions	3
1.5 Auxiliary Equipments	4
1.6 Cable List	4
1.7 System Configurations	4
1.8 Test System Layout.....	5
1.9 Modifications	5
1.10 Applicable Standards for Testing	5
1.11 Summary of Test Results	5
2. Emission Test	6
2.1 Test Results	6
2.2 Test Method and Limits	6
2.2.1 Test Method	6
2.2.2 Test Limits	6
2.3 Conducted Emission	7
2.3.1 Test Equipments	7
2.3.2 Test Site	7
2.3.3 Environment Conditions	7
2.3.4 Test Results	8
2.4 Radiated Emission	9
2.4.1 Test Equipments	9
2.4.2 Test Site	9
2.4.3 Environment Conditions	9
2.4.4 Test Results	10
Appendix A : Conducted Emission.....	11
Appendix B : Radiated Emission (3 m method below 1 GHz).....	12
Appendix C : Radiated Emission (3 m method above 1 GHz).....	13

1. General Information

1.1 Client Information

Applicant : SAMSUNG ELECTRONICS Co., Ltd.
 Address of Applicant : #416, Maetan-3dong, Yeongtong, Suwon, Gyeonggi, KR

Manufacturer : SAMSUNG ELECTRONICS Co., Ltd.
 Address of Applicant : #416, Maetan-3dong, Yeongtong, Suwon, Gyeonggi, KR

1.2 Test Laboratory

Name and Address : SGS Korea Co., Ltd.
 413-15, Gomae-dong, Giheung-gu, Yongin-si
 Gyeonggi-do, 446-901, Korea

FCC Registration No. : 656853
 Phone : + 82 31 8005 6020
 Fax : + 82 31 8005 6025
 e-mail : carl.lee@sgs.com

1.3 General Information of E.U.T.

Product Name	SAMSUNG Mobile Phone
Model Name	GT-S6102
Serial No.	Prototype
EMI Classification	Class B
Highest Internal Frequency	728 MHz
Hardware Version	REV 1.0
Software Version	S6102.001
I/O Ports	USB, I/O, Micro SD Port
Rated Voltage	AC 120 V, 60 Hz
Test Voltage	AC 120 V, 60 Hz

1.4 Operating Modes and Conditions

Operating mode	Operating condition
USB Data Communication mode.	Checked deviation of Operating mode

1.5 Auxiliary Equipments

Description	Model	Serial No.	Manufacturer
Desktop PC	M58P	-	Lenove
Monitor	L1742PEU	106NDMT0B339	LG
USB Mouse	MO56UO	520113063	DELL
USB Keyboard	KU-0225	0020550	Lenove
Micro SD Card	-	-	-

1.6 Cable List

Start		END		Cable Spec.	
Name	I/O Port	Name	I/O Port	Length	Shield
EUT	USB	Notebook Computer	-	0.8	Shield
	I/O	Ear-MIC Phone	-	1.5	Unshield
	Micro SD	Micro SD Card	-	-	-
Desktop PC	AC Input	Power Source	-	1.6	Unshield
	RGB	Monitor	RGB	1.7	Shield
	USB	USB Keyboard	USB	1.8	Unshield
	USB	USB Mouse	USB	1.7	Unshield
	LAN	Local Area Network	-	3.0	Unshield
Monitor	AC Input	Power Source	-	1.6	Unshield
	RGB	Desktop PC	RGB	1.7	Shield

1.7 System Configurations

Description	Model	Serial No.	Manufacturer
Battery	EB464358VU	THaBB10AS/4-B	SAMSUNG
Ear-MIC Phone	-	-	-
USB Cable	APCBU10BBE	KD1B201TS E	Fabricado en chine

1.8 Test System Layout

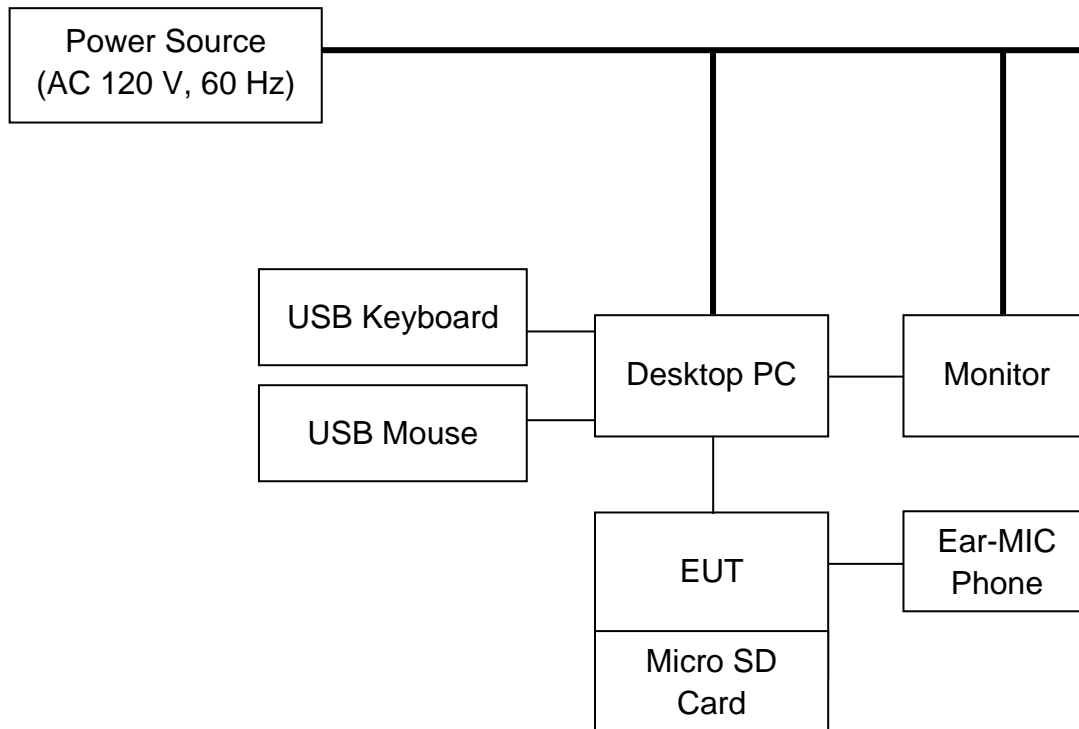

1.9 Modifications

There was no modified item during the test.

1.10 Applicable Standards for Testing

Standards	Status	Deviation
FCC Part 15 : 2009, Subpart B ANSI C63.4 : 2003 CISPR 22 : 2006	Applicable	No Deviation

1.11 Summary of Test Results

Test Item	Standards	Results
Conducted Emission	FCC Part 15 : 2009, Subpart B ANSI C63.4 : 2003 CISPR 22 : 2006	Complied
Radiated Emission	FCC Part 15 : 2009, Subpart B ANSI C63.4 : 2003 CISPR 22 : 2006	Complied

Note : Test methods of all test items are performed according to the basic standards in this table.

EMISSION

2.1 Test Results

Test Items	Standards	Test Results
Conducted Emission	FCC Part 15 : 2009, Subpart B ANSI C63.4 : 2003 CISPR 22 : 2006	Complied
Radiated Emission	FCC Part 15 : 2009, Subpart B ANSI C63.4 : 2003 CISPR 22 : 2006	Complied

2.2 Test Method and Limits

2.2.1 Test Method

Test Items	Measuring Frequency Range	RBW	Measuring Distance
Conducted Emission	0.15 MHz ~ 30 MHz	9 kHz	N/A
Radiated Emission	30 MHz ~ 1 GHz	120 kHz	10 m & 3 m
	Above 1 GHz	1 MHz	3 m

Note : 10 m method of radiated emission measurement is only applied to Class A equipment over the frequency range of 30 MHz ~ 1 GHz. Except this, 3 m method is applied to Class B equipment over the frequency range of 30 MHz ~ 1 GHz and Class A and Class B equipment above 1 GHz.

2.2.2 Test Limits

-Conducted Emission Limits

Frequency Range	Limits(dB(μ V))		Class
	Quasi-peak	Average	
0.15 MHz ~ 0.5 MHz	79	66	Class A
0.5 MHz ~ 30 MHz	73	60	
0.15 MHz ~ 0.5 MHz	66 to 56	56 to 46	Class B
0.5 MHz ~ 5 MHz	56	46	
5 MHz ~ 30 MHz	60	50	

Note : The lower limit shall apply at the transition frequencies. The limit decreases linearly with the logarithm of the frequency in the range 0.15 MHz to 0.5 MHz.

-Radiated Emission Limits below 1 GHz

Frequency Range	Limits(dB($\mu\text{V}/\text{m}$))		Class
	Quasi-peak		
30 MHz ~ 88 MHz	39.0		Class A
88 MHz ~ 216 MHz	43.5		
216 MHz ~ 960 MHz	46.4		
Above 960 MHz	49.5		
30 MHz ~ 88 MHz	40.0		Class B
88 MHz ~ 216 MHz	43.5		
216 MHz ~ 960 MHz	46.0		
Above 960 MHz	54.0		

-Radiated Emission Limits above 1 GHz

Frequency Range	Limits(dB($\mu\text{V}/\text{m}$))		Class
	Average	Peak	
Above 1 GHz	59.5	79.5	Class A
Above 1 GHz	54.0	74.0	Class B

Note : The limits of class A equipment is extrapolated using an extrapolation factor of 20 dB/decade because it was measured at 3 m distance not 10 m distance.

2.3 Conducted Emission

The initial preliminary exploratory scans were performed over the measuring frequency range (0.15 MHz to 30 MHz) using a max hold mode incorporating a Peak detector and Average detector and using the software of EMC32 (Version V8.50 from R&S). The final test data was measured using a Quasi-Peak detector and Average detector.

2.3.1 Test Equipments

Equipment	Model	Manufacturer	Serial No	Cal. Due Date
Two-Line V-Network	ENV216	R & S	100415	2012.06.25
Artificial Main Network	ESH2-Z5	R & S	1000195	2012.07.07
Pulse Limiter	ESH3-Z2	R & S	100850	2012.09.07
EMI Test Receiver	ESU8	R & S	100128	2012.01.14
Shielded Room	-	Will Tech	-	-

2.3.2 Test Site

Shield Room in Giheung Laboratory

2.3.3 Environment Conditions

Temperature : 21.0 °C

Humidity : 31.0 % R.H.

Atmospheric Pressure : 100.7 kPa

2.4 Radiated Emission

The initial preliminary exploratory scans were performed over the measuring frequency range (30 MHz to 6 GHz) using a max hold mode incorporating a Peak detector and using the software of EMC32 (Version V8.50 from R&S). The test data was measured using a Quasi-Peak detector below 1 GHz and a Peak and Average detector above 1 GHz. This test was performed up to 6 GHz. Measurements were made with the antenna positioned in both the horizontal and vertical planes of polarization. The antenna height was varied from 1 m to 4 m and the EUT was rotated 360° to find the maximum emitting point for each frequency.

2.4.1 Test Equipments

Equipment	Model	Manufacturer	Serial No	Cal. Due Date
EMI Test Receiver	ESU26	R & S	100194	2012.08.17
Bilog Antenna	CBL6112D	TESEQ	25233	2013.06.15
Double-Ridged Waveguide	HF906	R&S	100608	2012.04.12
Preamplifier	AFS42-0010180025-S-42	MITEQ	900699	2012.07.06
Amplifier	8447D	HP	1726A05143	2012.07.06
3 m Semi-Anechoic Chamber	-	Will Tech	-	-

Note : The Antenna calibration period is 2 years, but the other equipment calibration period are 1 year.

2.4.2 Test Site

3 m Semi-Anechoic Chamber in Giheung Laboratory

2.4.3 Environment Conditions

Temperature : 21.0 °C

Humidity : 32.0 % R.H.

Atmospheric Pressure : 100.7 kPa

2.4.4 Test Results

Below 1 GHz (3 m method)

Freq. (MHz)	Level (dB(μ V))	Pol. (H/V)	H (cm)	A ($^{\circ}$)	AF (dB)	CL (dB)	Amp. (dB)	F/S (dB(μ V/m))	Limit (dB(μ V/m))	Margin (dB)
240.0	52.0	H	130	199	12.89	1.87	25.90	40.9	46.0	5.1
555.3	36.2	H	120	157	19.16	2.80	27.47	30.7	46.0	15.3
720.0	41.7	H	100	329	20.08	3.17	27.74	37.2	46.0	8.8
774.6	34.2	H	100	184	20.42	3.31	27.58	30.3	46.0	15.7
832.4	39.4	H	110	159	20.99	3.44	27.34	36.5	46.0	9.5

Measurement Uncertainty : ± 4.04 dB (The confidential level is about 95%, $K = 2$)

Note : • AF = Antenna Factor • CL = Cable Loss • F/S = Field Strength
 • POL H = Horizontal • POL V = Vertical • Amp = Amplifier Gain
 • Margin = Limit – F/S • F/S = Level + AF + CL – Amp
 • A : Angle • H : Height

See Appendix B (Radiated Emission (3 m method below 1 GHz))

Above 1 GHz (3 m method)

Freq. (MHz)	Level (dB(μ V))	Pol. (H/V)	A ($^{\circ}$)	H (cm)	AF (dB)	CL (dB)	Amp. (dB)	F/S (dB(μ V/m))	Limit (dB(μ V/m))	Margin (dB)
Peak Detector										
1060.0	60.0	H	169	100	24.14	3.96	38.33	49.8	74.0	24.2
1064.0	55.5	H	251	100	24.15	3.97	38.33	45.3	74.0	28.7
1680.0	53.8	H	97	100	26.27	4.80	39.62	45.3	74.0	28.8
3000.0	49.6	H	291	100	29.71	6.19	39.20	46.3	74.0	27.7
Average Detector										
1060.0	43.7	H	169	100	24.14	3.96	38.33	33.5	54.0	20.5
1064.0	37.2	H	251	100	24.15	3.97	38.33	27.0	54.0	27.0
1680.0	35.5	H	97	100	26.27	4.80	39.62	27.0	54.0	27.1
3000.0	35.9	H	291	100	29.71	6.19	39.20	32.6	54.0	21.4

Measurement Uncertainty : ± 4.04 dB (The confidential level is about 95%, $K = 2$)

Note : • AF = Antenna Factor • CL = Cable Loss • F/S = Field Strength
 • POL H = Horizontal • POL V = Vertical • Amp = Amplifier Gain
 • Margin = Limit – F/S • F/S = Level + AF + CL – Amp
 • A : Angle • H : Height

See Appendix C (Radiated Emission (3 m method above 1 GHz))

Appendix A : Conducted Emission Neutral

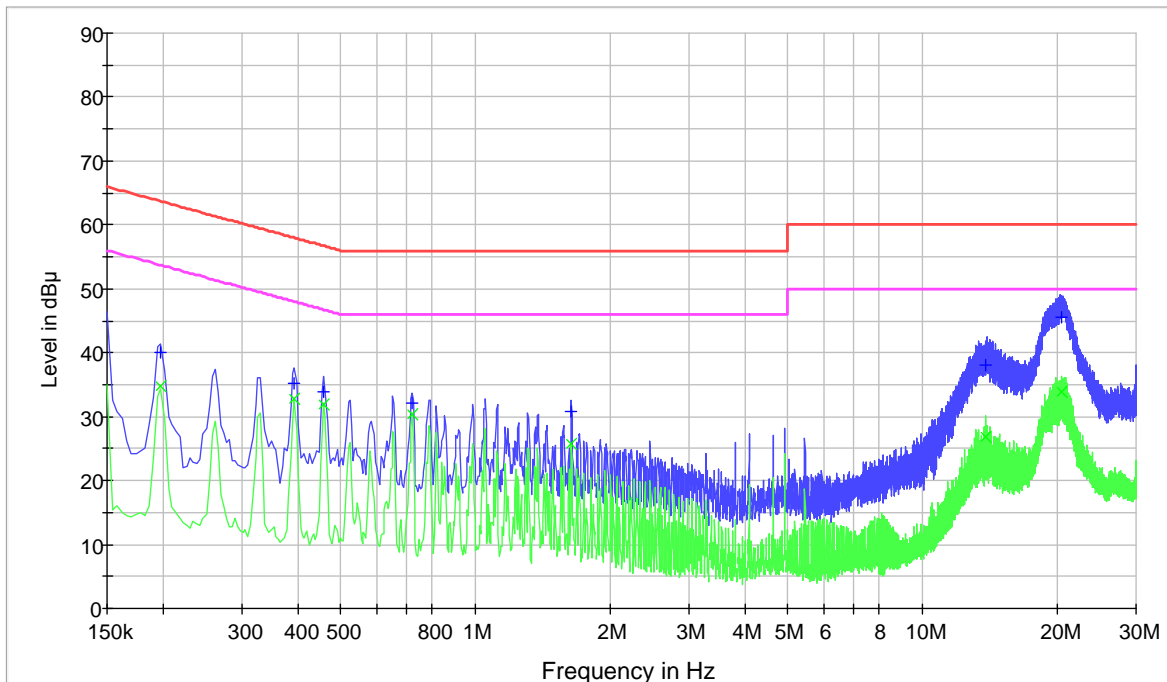

Hot

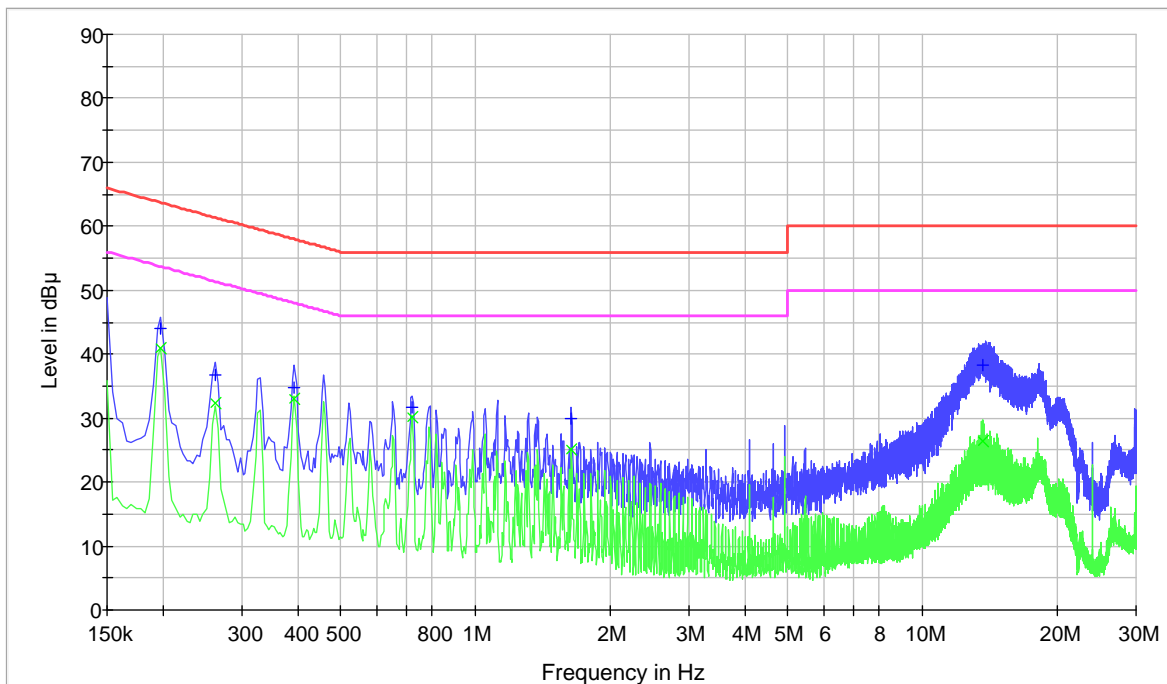

Appendix B : Radiated Emission (3 m method below 1 GHz)

Vertical

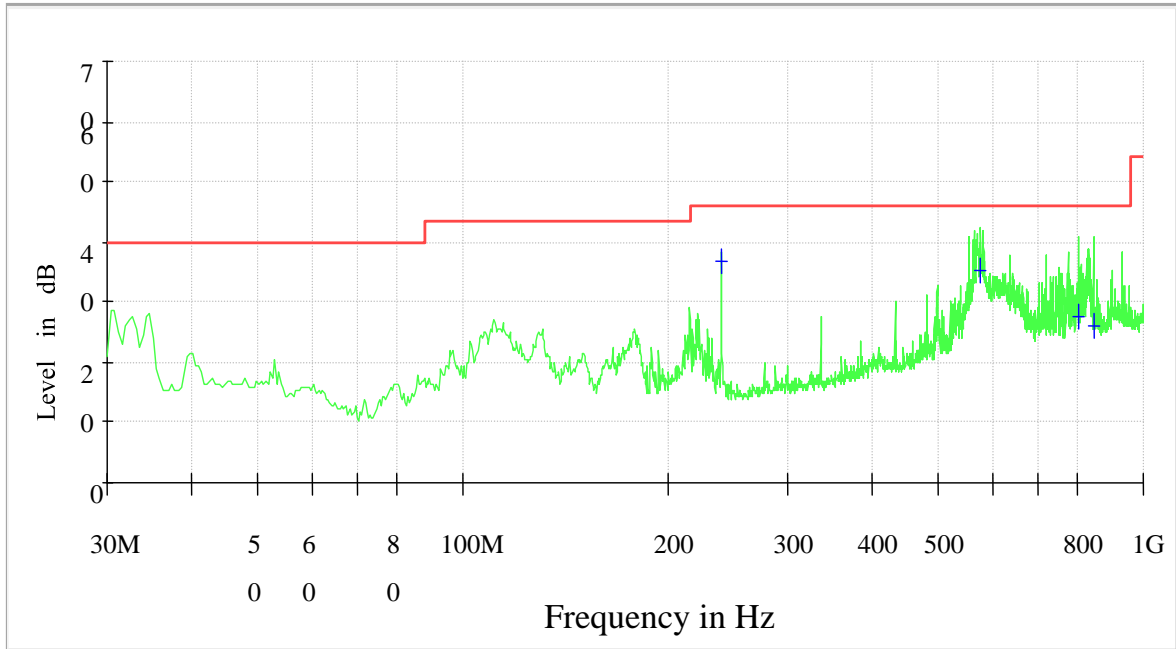

Horizontal

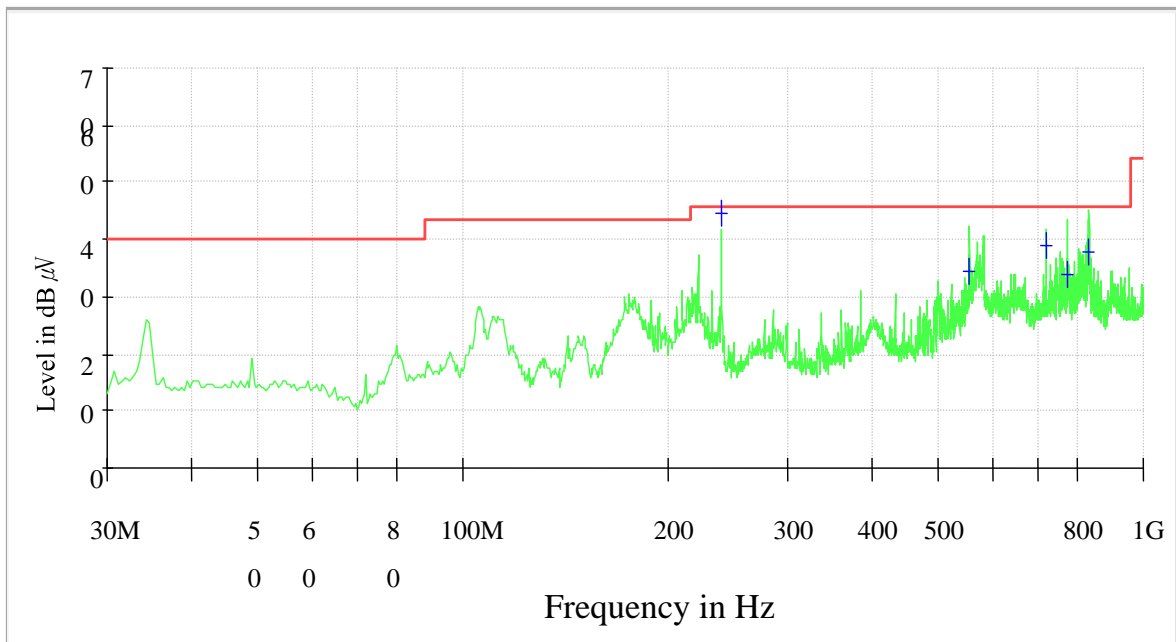

Appendix C : Radiated Emission (3 m method above 1 GHz)

Vertical

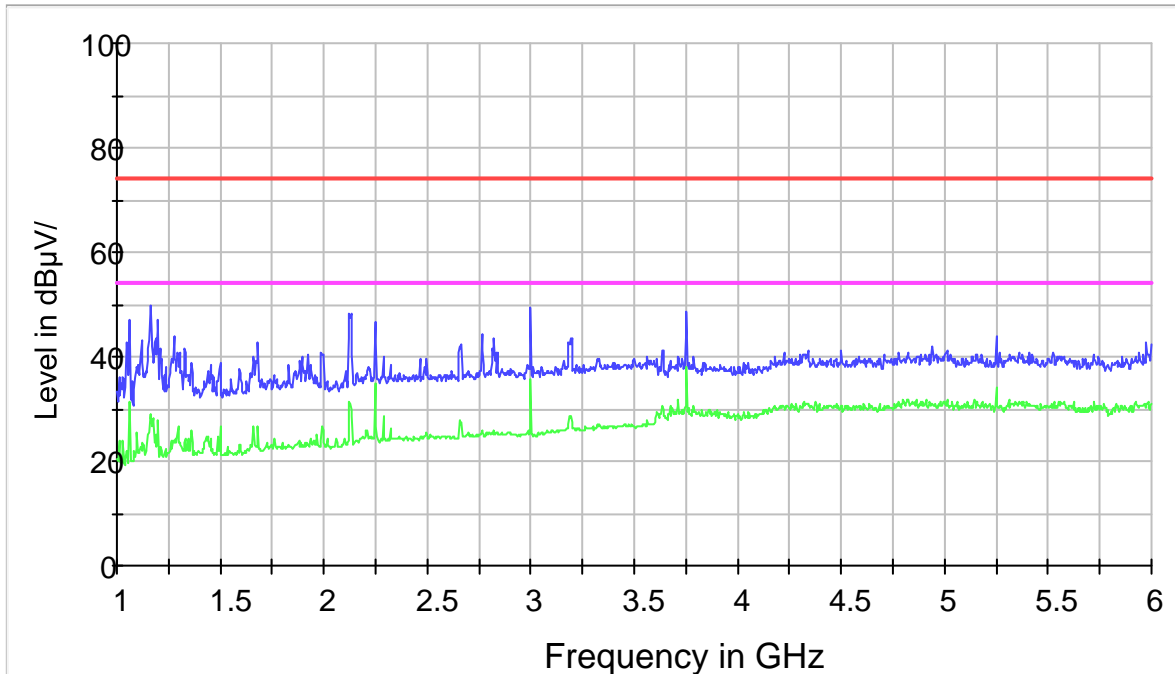

Horizontal

