



HCT CO., LTD.

CERTIFICATE OF COMPLIANCE FCC Certification

Applicant Name:
SAMSUNG Electronics Co., Ltd.

Date of Issue:
October 26, 2011

Address:
416 Maetan3-Dong, YeongTong-Gu, Suwon-Si,
Gyeonggi-Do, Korea, 443-742

Location:
HCT CO., LTD., 105-1, Jangam-ri, Majang-Myeon, Icheon-si,
Kyunggi-Do, Korea

Test Report No.: HCTR1110FR05

HCT FRN: 0005866421

FCC ID: A3LGTS5369

APPLICANT: SAMSUNG Electronics Co., Ltd.

FCC Model(s): GT-S5369
EUT Type: 850/1900 GSM/GPRS Phone with Bluetooth, WLAN and EDGE Rx Only
Tx Frequency: 824.20 - 848.80 MHz (GSM850)
1 850.20 - 1 909.80 MHz (GSM1900)

Rx Frequency: 869.20 - 893.80 MHz (GSM850)
1 930.20 - 1 989.80 MHz (GSM1900)

Max. RF Output Power: 0.225 W ERP GSM850 (23.52 dBm) / 1.016 W EIRP GSM1900 (30.07 dBm)

Emission Designator(s): 247KGXW (GSM850) 246GXW (GSM1900)

FCC Classification: Licensed Portable Transmitter Held to Ear (PCE)

FCC Rule Part(s): §22, §24, §2

The measurements shown in this report were made in accordance with the procedures specified in §2.947. I assume full responsibility for the accuracy and completeness of these measurements, and for the qualifications of all persons taking them.

HCT CO., LTD. Certifies that no party to this application has subject to a denial of Federal benefits that includes FCC benefits pursuant to section 5301 of the Anti-Drug Abuse Act of 1998,21 U.S. C.853(a)

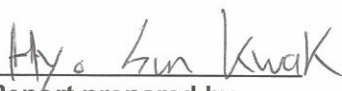
Report prepared by
: Hyo Sun Kwak
Test engineer of RF Team

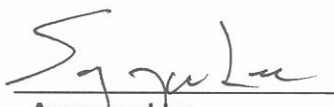
Approved by
: Sang Jun Lee
Manager of RF Team

This report only responds to the tested sample and may not be reproduced, except in full, without written approval of the HCT Co., Ltd.

| FCC CERTIFICATION REPORT | | | www.hct.co.kr |
|---------------------------------|------------------------------------|---|--|
| Test Report No. HCTR1110FR05 | Date of Issue: October 26, 2011 | EUT Type: 850/1900 GSM/GPRS Phone with Bluetooth, WLAN and EDGE Rx Only | FCC ID : A3LGTS5369 |

Version

| TEST REPORT NO. | DATE | DESCRIPTION |
|-----------------|------------------|-------------------------|
| HCTR1110FR05 | October 26, 2011 | - First Approval Report |
| | | |
| | | |
| | | |

Table of Contents

| | | |
|---|--|----|
| 1. GENERAL INFORMATION | | 4 |
| 2. INTRODUCTION | | 5 |
| 2.1. EUT DESCRIPTION..... | | 5 |
| 2.2. MEASURING INSTRUMENT CALIBRATION..... | | 5 |
| 2.3. TEST FACILITY | | 5 |
| 3. DESCRIPTION OF TESTS | | 6 |
| 3.1 EFFECTIVE RADIATED POWER/EQUIVALENT ISOTROPIC RADIATED POWER..... | | 6 |
| 3.2 PEAK- TO- AVERAGE RATIO | | 7 |
| 3.3 OCCUPIED BANDWIDTH. | | 8 |
| 3.4 SPURIOUS AND HARMONIC EMISSIONS AT ANTENNA TERMINAL..... | | 9 |
| 3.5 RAIDATED SPURIOUS AND HARMONIC EMISSIONS | | 10 |
| 3.6 FREQUENCY STABILITY / VARIATION OF AMBIENT TEMPERATURE | | 11 |
| 4. LIST OF TEST EQUIPMENT | | 12 |
| 5. SUMMARY OF TEST RESULTS | | 13 |
| 6. SAMPLE CALCULATION | | 14 |
| 7. TEST DATA | | 15 |
| 7.1 CONDUCTED OUTPUT POWER | | 15 |
| 7.2 PEAK-TO-AVERAGE RATIO | | 15 |
| 7.3 OCCUPIED BANDWIDTH | | 16 |
| 7.4 CONDUCTED SPURIOUS EMISSIONS | | 16 |
| 7.4.1 BAND EDGE..... | | 16 |
| 7.5 EFFECTIVE RADIATED POWER OUTPUT | | 17 |
| 7.6 EQUIVALENT ISOTROPIC RADIATED POWER | | 18 |
| 7.7 RADIATED SPURIOUS EMISSIONS | | 19 |
| 7.7.1 RADIATED SPURIOUS EMISSIONS (GSM850)..... | | 19 |
| 7.7.2 RADIATED SPURIOUS EMISSIONS (GSM1900)..... | | 20 |
| 7.8 FREQUENCY STABILITY / VARIATION OF AMBIENT TEMPERATURE | | 21 |
| 7.8.1 FREQUENCY STABILITY (GSM850) | | 21 |
| 7.8.2 FREQUENCY STABILITY (GSM1900) | | 22 |
| 8. TEST PLOTS..... | | 23 |

MEASUREMENT REPORT

1. GENERAL INFORMATION

Applicant Name: SAMSUNG Electronics Co., Ltd.

Address: 416 Maetan3-Dong, YeongTong-Gu, Suwon-Si, Gyeonggi-Do, Korea, 443-742

FCC ID: A3LGTS5369

Application Type: Certification

FCC Classification: Licensed Portable Transmitter Held to Ear (PCE)

FCC Rule Part(s): §22, §24, §2

EUT Type: 850/1900 GSM/GPRS Phone with Bluetooth, WLAN and EDGE Rx Only

FCC Model name(s): GT-S5369

Tx Frequency: 824.20 - 848.80 MHz (GSM850)
1 850.20 - 1 909.80 MHz (GSM1900)

Rx Frequency: 869.20 - 893.80 MHz (GSM850)
1 930.20 - 1 989.80 MHz (GSM1900)

Max. RF Output Power: 0.225 W ERP GSM850 (23.52 dBm) / 1.016 W EIRP GSM1900 (30.07 dBm)

Emission Designator(s): 247KGXW (GSM850) 246GXW (GSM1900)

Antenna Specification
 Manufacturer: ETHERTRONICS
 Antenna type: INTERNAL Antenna
 Peak Gain: -2.49 dBi

Date(s) of Tests: October 18, 2011 ~ October 24, 2011

| FCC CERTIFICATION REPORT | | | www.hct.co.kr |
|---------------------------------|------------------------------------|---|--|
| Test Report No. HCTR1110FR05 | Date of Issue: October 26, 2011 | EUT Type: 850/1900 GSM/GPRS Phone with Bluetooth, WLAN and EDGE Rx Only | FCC ID : A3LGTS5369 |

2. INTRODUCTION

2.1. EUT DESCRIPTION

The SAMSUNG Electronics Co., Ltd. GT-S5369 850/1900 GSM/GPRS Phone with Bluetooth, WLAN and EDGE Rx Only consists of GSM850, GSM1900 and GPRS Class12.

2.2. MEASURING INSTRUMENT CALIBRATION

The measuring equipment, which was utilized in performing the tests documented herein, has been calibrated in accordance with the manufacturer's recommendations for utilizing calibration equipment, which is traceable to recognized national standards.

2.3. TEST FACILITY

The SAC(Semi-Anechoic Chamber) and conducted measurement facility used to collect the radiated data are located at the 105-1, Jangam-ri, Majang-Myeon, Icheon-si, Kyunggi-Do, 467-811, Korea. The site is constructed in conformance with the requirements of ANSI C63.4 and CISPR Publication 22. Detailed description of test facility was submitted to the Commission and accepted dated March 02, 2011 (Registration Number: 90661)

| FCC CERTIFICATION REPORT | | | www.hct.co.kr |
|---------------------------------|------------------------------------|---|--|
| Test Report No. HCTR1110FR05 | Date of Issue: October 26, 2011 | EUT Type: 850/1900 GSM/GPRS Phone with Bluetooth, WLAN and EDGE Rx Only | FCC ID : A3LGTS5369 |

3. DESCRIPTION OF TESTS

3.1 EFFECTIVE RADIATED POWER/EQUIVALENT ISOTROPIC RADIATED POWER

Test Set-up

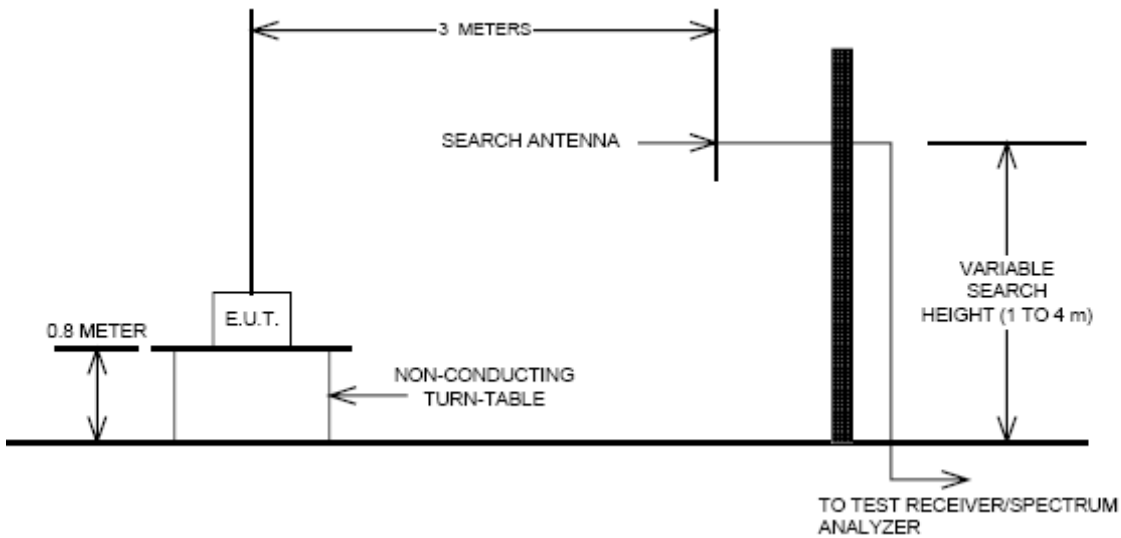

Test Procedure

Radiated emission measurements were performed at an SAC(Semi-Anechoic Chamber)

The equipment under test is placed on a non-conductive styrofoam resin table 3-meters from the receive antenna. A styrofoam turntable was rotated 360° and the receiving antenna scanned from 1-4m in order to capture the maximum emission. A half wave dipole was substituted in place of the EUT. This dipole antenna was driven by a signal generator and the previously recorded signal was duplicated.

The maximum EIRP was calculated by adding the forward power to the calibrated source plus its appropriate gain value. These steps were carried out with the receiving antenna in both vertical and horizontal polarization. For readings above 1GHz, the above procedure is repeated using horn antennas and the difference between the gain of the horn and an isotropic antenna are taken into consideration.

| FCC CERTIFICATION REPORT | | | www.hct.co.kr |
|---------------------------------|------------------------------------|---|--|
| Test Report No. HCTR1110FR05 | Date of Issue: October 26, 2011 | EUT Type: 850/1900 GSM/GPRS Phone with Bluetooth, WLAN and EDGE Rx Only | FCC ID : A3LGTS5369 |

3.2 PEAK- TO- AVERAGE RATIO

A peak to average ratio measurement is performed at the conducted port of the EUT. For CDMA and WCDMA signals, the spectrum analyzers Complementary Cumulative Distribution Function (CCDF) measurement profile is used to determine the largest deviation between the average and the peak power of the EUT in a given bandwidth. The CCDF curve shows how much time the peak waveform spends at or above a given average power level. The percent of time the signal spends at or above the level defines the probability for that particular power level. For GSM signals, an average and a peak trace are used on a spectrum analyzer to determine the largest deviation between the average and the peak power of the EUT in a bandwidth greater than the emission bandwidth. Plots of the EUT's Peak- to- Average Ratio are shown herein.

| FCC CERTIFICATION REPORT | | | www.hct.co.kr |
|---------------------------------|------------------------------------|---|--|
| Test Report No. HCTR1110FR05 | Date of Issue: October 26, 2011 | EUT Type: 850/1900 GSM/GPRS Phone with Bluetooth, WLAN and EDGE Rx Only | FCC ID : A3LGTS5369 |

3.3 OCCUPIED BANDWIDTH.

Test set-up

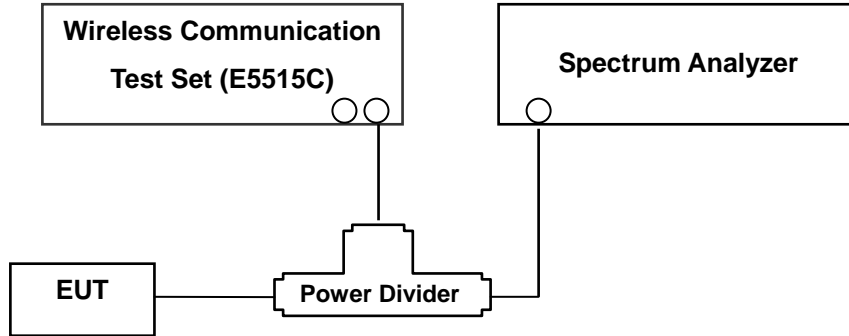

(Configuration of conducted Emission measurement)

Test Procedure

The EUT was setup to maximum output power at its lowest channel. The occupied bandwidth was measured using a spectrum analyzer. The measurements are repeated for the highest and a middle channel. The EUT's occupied bandwidth is measured as the width of the signal between two points, one below the carrier center frequency and one above the carrier frequency, outside of which all emissions are attenuated at least 26 dB below the transmitter power. Plots of the EUT's occupied bandwidth are shown herein.

| FCC CERTIFICATION REPORT | | | www.hct.co.kr |
|---------------------------------|------------------------------------|---|--|
| Test Report No. HCTR1110FR05 | Date of Issue: October 26, 2011 | EUT Type: 850/1900 GSM/GPRS Phone with Bluetooth, WLAN and EDGE Rx Only | FCC ID : A3LGTS5369 |

3.4 SPURIOUS AND HARMONIC EMISSIONS AT ANTENNA TERMINAL.

Test Procedure

The level of the carrier and the various conducted spurious and harmonic frequencies is measured by means of a calibrated spectrum analyzer.

The EUT was setup to maximum output power at its lowest channel. The Resolution BW of the analyzer is set to 1 % of the emission bandwidth to show compliance with the – 13 dBm limit, in the 1 MHz bands immediately outside and adjacent to the edge of the frequency block. The 1 MHz RBW was used to scan from 10 MHz to 10 GHz. (GSM1900 Mode: 10 MHz to 20 GHz). A display line was placed at – 13 dBm to show compliance. The high, lowest and a middle channel were tested for out of band measurements.

- Band Edge Requirement : In the 1MHz bands immediately outside and adjacent to the frequency block, a resolution bandwidth of at least 1 percent of the emission bandwidth of the fundamental emission of the transmitter may be employed to measure the out of band Emissions. Limit, -13dBm.

| FCC CERTIFICATION REPORT | | | www.hct.co.kr |
|---------------------------------|------------------------------------|---|--|
| Test Report No. HCTR1110FR05 | Date of Issue: October 26, 2011 | EUT Type: 850/1900 GSM/GPRS Phone with Bluetooth, WLAN and EDGE Rx Only | FCC ID : A3LGTS5369 |

3.5 RAIDATED SPURIOUS AND HARMONIC EMISSIONS

Test Set-up

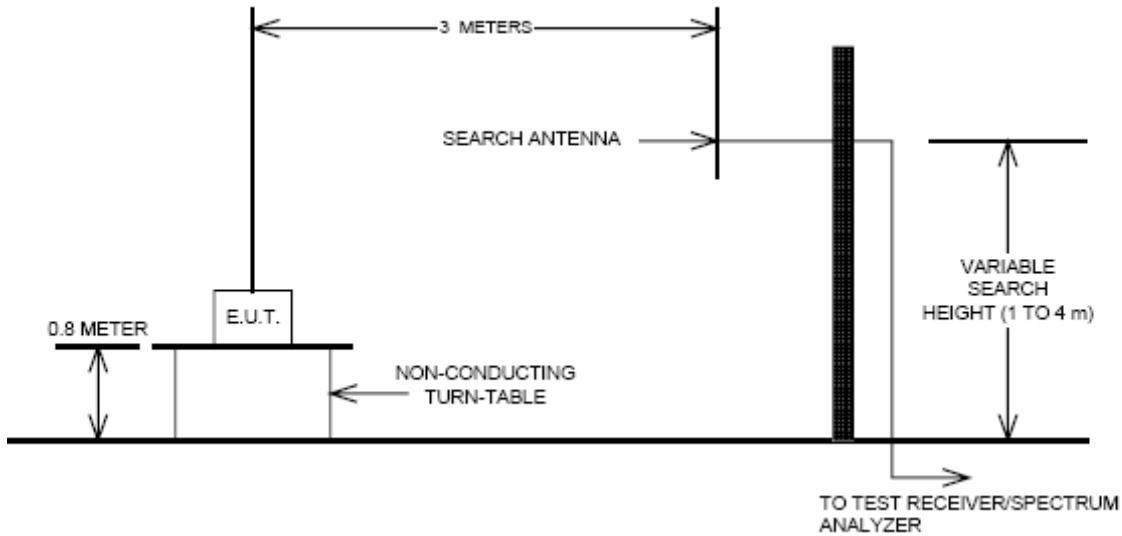

The measurement facilities used for this test have been documented in previous filings with the commission pursuant to section § 2.948. The SAC(Semi-Anechoic Chamber) meets requirements in ANSI C63.4 –2003. A mast capable of lifting the receiving antenna from a height of one to four meters is used together with a rotatable styrofoam platform mounted at three from the antenna mast.

- 1) The unit mounted on a styrofoam turntable 1.5 m × 1.0 m × 0.80 m is 0.8 meter above test site ground level.
- 2) During the emission test, the turntable is rotated and the EUT is manipulated to find the configuration resulting in maximum emission under normal condition of installation and operation.
- 3) The antenna height and polarization are also varied from 1 to 4 meters until the maximum signal is found.
- 4) The spectrum shall be scanned up to the 10th harmonic of the fundamental frequency.

Test Procedure

The equipment under test is placed on a non-conductive styrofoam resin table 3-meters from the receive antenna. A styrofoam turntable was rotated 360° and the receiving antenna scanned from 1-4m in order to capture the maximum emission. A half wave dipole was substituted in place of the EUT. This dipole antenna was driven by a signal generator and the previously recorded signal was duplicated.

The maximum EIRP was calculated by adding the forward power to the calibrated source plus its appropriate gain value. These steps were carried out with the receiving antenna in both vertical and horizontal polarization. For readings above 1GHz, the above procedure is repeated using horn antennas and the difference between the gain of the horn and an isotropic antenna are taken into consideration.

| FCC CERTIFICATION REPORT | | | www.hct.co.kr |
|---------------------------------|------------------------------------|---|--|
| Test Report No. HCTR1110FR05 | Date of Issue: October 26, 2011 | EUT Type: 850/1900 GSM/GPRS Phone with Bluetooth, WLAN and EDGE Rx Only | FCC ID : A3LGTS5369 |

3.6 FREQUENCY STABILITY / VARIATION OF AMBIENT TEMPERATURE

Test Set-up

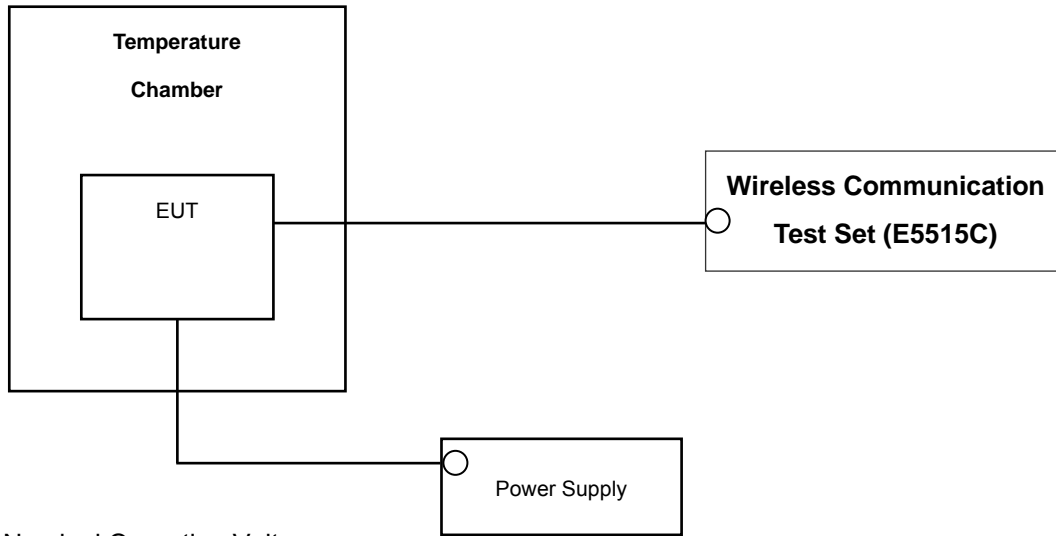

* Nominal Operating Voltage

Test Procedure

The frequency stability of the transmitter is measured by:

- a.) **Temperature:** The temperature is varied from - 30 °C to + 50 °C using an environmental chamber.
- b.) **Primary Supply Voltage:** The primary supply voltage is varied from battery end point to 115 % of the voltage normally at the input to the device or at the power supply terminals if cables are not normally supplied.

Specification — the frequency stability shall be sufficient to ensure that the fundamental emission stays within the authorized frequency block. The frequency stability of the transmitter shall be maintained within $\pm 0.00025\%$ (± 2.5 ppm) of the center frequency.

Time Period and Procedure:

The carrier frequency of the transmitter is measured at room temperature (20°C to provide a reference).

1. The equipment is turned on in a "standby" condition for one minute before applying power to the transmitter. Measurement of the carrier frequency of the transmitter is made within one minute after applying power to the transmitter.
2. Frequency measurements are made at 10°C intervals ranging from -30°C to +50°C. A period of at least one half-hour is provided to allow stabilization of the equipment at each temperature level.

NOTE: The EUT is tested down to the battery endpoint.

| FCC CERTIFICATION REPORT | | | www.hct.co.kr |
|---------------------------------|------------------------------------|---|--|
| Test Report No. HCTR1110FR05 | Date of Issue: October 26, 2011 | EUT Type: 850/1900 GSM/GPRS Phone with Bluetooth, WLAN and EDGE Rx Only | FCC ID : A3LGTS5369 |

4. LIST OF TEST EQUIPMENT

| Manufacture | Model/ Equipment | Serial Number | Calibration Interval | Calibration Due |
|-------------------|--------------------------------|---------------|----------------------|-----------------|
| R&S | N9020A | MY51110020 | Annual | 04/16/2012 |
| Agilent | E4416A/ Power Meter | GB41291412 | Annual | 01/04/2012 |
| Agilent | E9327A/ Power Sensor | MY4442009 | Annual | 05/02/2012 |
| Agilent | 8960 (E5515C)/ Base Station | GB44400269 | Annual | 02/10/2012 |
| MITEQ | AMF-6D-001180-35-20P/AMP | 990893 | Annual | 05/02/2012 |
| Wainwright | WHK1.2/15G-10EF/H.P.F | 2 | Annual | 05/02/2012 |
| Wainwright | WHK3.3/18G-10EF/H.P.F | 1 | Annual | 05/02/2012 |
| Agilent | 775D/ Dual Directional Coupler | 12922 | Annual | 12/29/2011 |
| Agilent | 11636B/ Power Divider | 11377 | Annual | 12/29/2011 |
| Digital | EP-3010/ Power Supply | 3110117 | Annual | 01/04/2012 |
| Schwarzbeck | UHAP/ Dipole Antenna | 949 | Biennial | 03/18/2012 |
| Schwarzbeck | UHAP/ Dipole Antenna | 950 | Biennial | 03/18/2012 |
| Korea Engineering | KR-1005L / Chamber | KRAB07063-2CH | Annual | 12/28/2011 |
| Schwarzbeck | BBHA 9120D/ Horn Antenna | 147 | Biennial | 04/13/2012 |
| Agilent | E4440A/Spectrum Analyzer | US45303008 | Annual | 05/02/2012 |

5. SUMMARY OF TEST RESULTS

| FCC Part Section(s) | Test Description | Test Limit | Test Condition | Test Result |
|---------------------------------|--|--|----------------|-------------|
| 2.1049, 22.917(a), 24.238(a) | Occupied Bandwidth | N/A | CONDUCTED | PASS |
| 2.1051, 22.917(a), 24.238(a) | Band Edge / Spurious and Harmonic Emissions at Antenna Terminal. | < 43 + 10log ₁₀ (P[Watts]) at Band Edge and for all out-of-band emissions | | PASS |
| 2.1046 | Conducted Output Power | N/A | | PASS |
| 24.232(d) | Peak- to- Average Ratio | < 13 dB | | PASS |
| 2.1055, 22.355, 24.235 | Frequency stability / variation of ambient temperature | < 2.5 ppm | | PASS |
| 22.913(a)(2) 24.232(c) | Effective Radiated Power | < 7 Watts max. ERP | RADIATED | PASS |
| | Equivalent Isotropic Radiated Power | < 2 Watts max. EIRP | | PASS |
| 2.1053, 22.917(a), 24.238(a) | Radiated Spurious and Harmonic Emissions | < 43 + 10log ₁₀ (P[Watts]) for all out-of band emissions | | PASS |

6. SAMPLE CALCULATION

A. ERP Sample Calculation

| Mode | Ch./ Freq. | | Measured Level(dBm) | Substitute LEVEL(dBm) | Ant. Gain | C.L | Pol. | ERP | |
|--------|------------|------------|---------------------|-----------------------|-----------|------|------|------|-------|
| | channel | Freq.(MHz) | | | | | | W | dBm |
| GSM850 | 128 | 824.20 | -11.56 | 34.28 | -8.32 | 1.17 | H | 0.30 | 24.79 |

ERP = SubstituteLEVEL(dBm) + Ant. Gain – CL(Cable Loss)

- 1) The EUT mounted on a wooden tripod is 0.8 meter above test site ground level.
- 2) During the test , the turn table is rotated and the antenna height is also varied from 1 to 4 meters until the maximum signal is found.
- 3) Record the field strength meter's level.
- 4) Replace the EUT with dipole/Horn antenna that is connected to a calibrated signal generator.
- 5) Increase the signal generator output till the field strength meter's level is equal to the item (3).
- 6) The signal generator output level with Ant. Gain and cable loss are the rating of effective radiated power (ERP).

B. Emission Designator

GSM Emission Designator

Emission Designator = 249KGXW

GSM BW = 249 kHz

G = Phase Modulation

X = Cases not otherwise covered

W = Combination (Audio/Data)

7. TEST DATA

7.1 CONDUCTED OUTPUT POWER

A base station simulator was used to establish communication with the EUT. The base station simulator parameters were set to produce the maximum power from the EUT. This device was tested under all configurations and the highest power is reported. Conducted Output Powers of EUT are reported below.

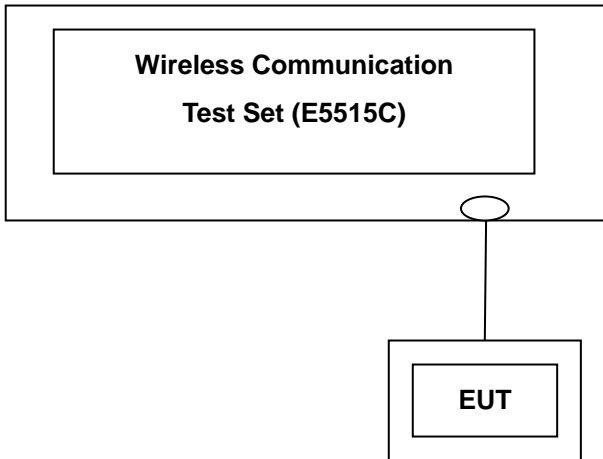

Test Result

| Band | Channel | Voice | GPRS Data | | | |
|-------------|---------|-----------|----------------------|----------------------|----------------------|----------------------|
| | | GSM (dBm) | GPRS 1 TX Slot (dBm) | GPRS 2 TX Slot (dBm) | GPRS 3 TX Slot (dBm) | GPRS 4 TX Slot (dBm) |
| GSM 850 | 128 | 32.25 | 32.25 | 32.22 | 28.79 | 26.79 |
| | 190 | 32.20 | 32.20 | 32.16 | 28.74 | 26.75 |
| | 251 | 32.11 | 32.11 | 32.06 | 28.65 | 26.67 |
| GSM 1900 | 512 | 29.33 | 29.32 | 29.30 | 25.80 | 23.78 |
| | 661 | 29.22 | 29.22 | 29.20 | 25.71 | 23.71 |
| | 810 | 29.45 | 29.44 | 29.43 | 25.95 | 23.96 |

(GSM Conducted Maximum Output Powers)

Note : Detecting mode is average.

7.2 PEAK-TO-AVERAGE RATIO

- Plots of the EUT's Peak- to- Average Ratio are shown Page 27.

| FCC CERTIFICATION REPORT | | | www.hct.co.kr |
|---------------------------------|------------------------------------|---|--|
| Test Report No. HCTR1110FR05 | Date of Issue: October 26, 2011 | EUT Type: 850/1900 GSM/GPRS Phone with Bluetooth, WLAN and EDGE Rx Only | FCC ID : A3LGTS5369 |

7.3 OCCUPIED BANDWIDTH

| Band | Channel | Frequency(MHz) | Data (GSM: kHz) |
|---------|---------|----------------|-----------------|
| GSM850 | 128 | 824.20 | 245.3090 |
| | 190 | 836.60 | 247.4056 |
| | 251 | 848.80 | 244.8853 |
| GSM1900 | 512 | 1850.20 | 246.3074 |
| | 661 | 1880.00 | 241.8012 |
| | 810 | 1909.80 | 246.4357 |

- Plots of the EUT's Occupied Bandwidth are shown Page 24 ~ 26.

7.4 CONDUCTED SPURIOUS EMISSIONS

| Band | Channel | Frequency of Maximum Harmonic (GHz) | Maximum Data (dBm) |
|---------|---------|-------------------------------------|--------------------|
| GSM850 | 128 | 7.5000 | -29.99 |
| | 190 | 7.0250 | -30.27 |
| | 251 | 7.1750 | -29.16 |
| GSM1900 | 512 | 13.2530 | -25.97 |
| | 661 | 13.2000 | -26.30 |
| | 810 | 13.8130 | -26.54 |

- Plots of the EUT's Conducted Spurious Emissions are shown Page 31 ~ 37.

7.4.1 BAND EDGE

- Plots of the EUT's Band Edge are shown Page 27 ~ 31.

7.5 EFFECTIVE RADIATED POWER OUTPUT

(GSM850 Mode)

| Ch./ Freq. | | Measured Level(dBm) | Substitute LEVEL (dBm) | Ant. Gain (dBd) | C.L | Pol. | ERP | |
|------------|------------|---------------------|------------------------|-----------------|------|------|------|-------|
| channel | Freq.(MHz) | | | | | | W | dBm |
| 128 | 824.20 | -17.16 | 31.77 | -10.54 | 1.61 | V | 0.09 | 19.62 |
| 190 | 836.60 | -15.49 | 33.43 | -10.50 | 1.67 | V | 0.13 | 21.26 |
| 251 | 848.80 | -13.43 | 35.63 | -10.47 | 1.64 | V | 0.22 | 23.52 |

Note: Standard batteries are the only options for this phone

NOTES:

Effective Radiated Power Output Measurements by Substitution Method

according to ANSI/TIA/EIA-603-C-2004, Aug. 17, 2004:

The EUT was placed on a non-conductive styrofoam resin table table 3-meters from the receive antenna. The receive antenna height and turntable rotation was adjusted for the highest reading on the receive spectrum analyzer. For CDMA signals, a peak detector is used, with RBW = VBW = 3 MHz. For WCDMA signals, a peak detector is used, with RBW = VBW = 5MHz. For AMPS, GSM, and NADC TDMA signals, a peak detector is used, with RBW = VBW = 1 MHz. A half-wave dipole was substituted in place of the EUT. This dipole antenna was driven by a signal generator and the level of the signal generator was adjusted to obtain the same receive spectrum analyzer reading. The conducted power at the terminals of the dipole is measured. The ERP is recorded.

This device was tested under all configurations and the highest power is reported in GSM mode and using a Power Control Level of "0" in the PCS Band and "5" in the Cellular Band. This unit was tested with its standard battery. Also, we have done x, y, z planes in EUT and horizontal and vertical polarization in detecting antenna. The worst case of the EUT is in y plane in GSM850 mode. Also worst case of detecting Antenna is in vertical polarization in GSM850 mode.

| FCC CERTIFICATION REPORT | | | www.hct.co.kr |
|---------------------------------|------------------------------------|---|--|
| Test Report No. HCTR1110FR05 | Date of Issue: October 26, 2011 | EUT Type: 850/1900 GSM/GPRS Phone with Bluetooth, WLAN and EDGE Rx Only | FCC ID : A3LGTS5369 |

7.6 EQUIVALENT ISOTROPIC RADIATED POWER

(GSM1900 Mode)

| Ch./ Freq. | | Measured | Substitute | Ant. Gain | C.L | Pol. | EIRP | |
|------------|------------|------------|-------------|-----------|------|------|------|-------|
| channel | Freq.(MHz) | Level(dBm) | LEVEL (dBm) | (dBi) | | | W | dBm |
| 512 | 1,850.20 | -11.70 | 22.01 | 10.40 | 2.83 | H | 0.91 | 29.57 |
| 661 | 1,880.00 | -11.33 | 22.45 | 10.43 | 2.81 | H | 1.02 | 30.07 |
| 810 | 1,909.80 | -11.53 | 22.46 | 10.47 | 2.86 | H | 1.02 | 30.07 |

Note: Standard batteries are the only options for this phone

NOTES:

Equivalent Isotropic Radiated Power Measurements by Substitution Method
according to ANSI/TIA/EIA-603-C-2004, Aug. 17, 2004:

The EUT was placed on a non-conductive styrofoam resin table table 3-meters from the receive antenna. The receive antenna height and turntable rotation was adjusted for the highest reading on the receive spectrum analyzer. For CDMA signals, a peak detector is used, with RBW = VBW = 3 MHz. For WCDMA signals, a peak detector is used, with RBW = VBW = 5MHz. For AMPS, GSM, and NADC TDMA signals, a peak detector is used, with RBW = VBW = 1 MHz. A Horn antenna was substituted in place of the EUT. This Horn antenna was driven by a signal generator and the level of the signal generator was adjusted to obtain the same receive spectrum analyzer reading. The conducted power at the terminals of the Horn antenna is measured. The difference between the gain of the horn and an isotropic antenna is taken into consideration and the EIRP is recorded.

This device was tested under all configurations and the highest power is reported in GSM mode and using a Power Control Level of "0" in the PCS Band and "5" in the Cellular Band. This unit was tested with its standard battery. Also, we have done x, y, z planes in EUT and horizontal and vertical polarization in detecting antenna. The worst case of the EUT is in x plane in GSM1900 mode. Also worst case of detecting Antenna is in horizontal polarization in GSM1900 mode.

| FCC CERTIFICATION REPORT | | | www.hct.co.kr |
|---------------------------------|------------------------------------|---|--|
| Test Report No. HCTR1110FR05 | Date of Issue: October 26, 2011 | EUT Type: 850/1900 GSM/GPRS Phone with Bluetooth, WLAN and EDGE Rx Only | FCC ID : A3LGTS5369 |

7.7 RADIATED SPURIOUS EMISSIONS

7.7.1 RADIATED SPURIOUS EMISSIONS (GSM850)

- MEASURED OUTPUT POWER: 23.52 dBm = 0.225 W
- MODULATION SIGNAL: GSM850
- DISTANCE: 3 meters
- LIMIT: $-(43 + 10 \log_{10}(W)) =$ - 36.52 dBc

| Ch. | Freq.(MHz) | Measured Level [dBm] | Ant. Gain (dBd) | Substitute Level [dBm] | C.L | Pol. | ERP (dBm) | dBc |
|----------------|------------|-------------------------|--------------------|------------------------------|------|------|--------------|--------|
| 128 (824.2) | 1,648.40 | -48.50 | 9.66 | -53.13 | 2.63 | H | -46.10 | -69.62 |
| | 2,472.60 | -36.39 | 10.79 | -39.23 | 3.55 | V | -31.99 | -55.51 |
| | 3,296.80 | -44.29 | 11.76 | -47.66 | 4.79 | H | -40.69 | -64.21 |
| 190 (836.6) | 1,673.20 | -50.46 | 9.77 | -55.16 | 2.67 | H | -48.06 | -71.58 |
| | 2,509.80 | -38.84 | 10.82 | -41.95 | 3.61 | V | -34.74 | -58.26 |
| | 3,346.40 | -45.94 | 11.87 | -50.17 | 4.94 | H | -43.24 | -66.76 |
| 251 (848.8) | 1,697.60 | -50.97 | 9.94 | -56.10 | 2.61 | V | -48.77 | -72.29 |
| | 2,546.40 | -41.99 | 10.84 | -45.63 | 3.60 | V | -38.39 | -61.91 |
| | 3,395.20 | -49.32 | 11.98 | -54.39 | 4.11 | H | -46.52 | -70.04 |

NOTES: 1. Radiated Spurious Emission Measurements at 3 meters by Substitution Method

according to ANSI/TIA/EIA-603-C-2004, Aug. 17, 2004:

2. The magnitude of spurious emissions attenuated more than 20dB below the limit above 5th Harmonic for all channel.

3. we have done x, y, z planes in EUT and horizontal and vertical polarization in detecting antenna.

| FCC CERTIFICATION REPORT | | | www.hct.co.kr |
|---------------------------------|------------------------------------|---|--|
| Test Report No. HCTR1110FR05 | Date of Issue: October 26, 2011 | EUT Type: 850/1900 GSM/GPRS Phone with Bluetooth, WLAN and EDGE Rx Only | FCC ID : A3LGTS5369 |

7.7.2 RADIATED SPURIOUS EMISSIONS (GSM1900)

- MEASURED OUTPUT POWER: 30.07 dBm = 1.016 W
- MODULATION SIGNAL: GSM1900
- DISTANCE: 3 meters
- LIMIT: $-(43 + 10 \log_{10}(W)) =$ - 43.07 dBc

| Ch. | Freq.(MHz) | Measured Level [dBm] | Ant. Gain (dBi) | Substitute Level [dBm] | C.L | Pol. | EIRP (dBm) | dBc |
|-----------------|------------|-------------------------|--------------------|------------------------------|------|------|---------------|--------|
| 512 (1850.2) | 3,700.40 | -47.75 | 12.36 | -49.54 | 4.87 | V | -42.05 | -72.12 |
| | 5,550.60 | -58.04 | 12.61 | -54.49 | 6.66 | H | -48.54 | -78.61 |
| | 7,400.80 | -57.96 | 10.97 | -46.73 | 6.60 | H | -42.36 | -72.43 |
| 661 (1880.0) | 3,760.00 | -51.07 | 12.40 | -52.79 | 4.88 | V | -45.27 | -75.34 |
| | 5,640.00 | -55.49 | 12.65 | -51.70 | 6.54 | H | -45.59 | -75.66 |
| | 7,520.00 | -58.75 | 10.84 | -46.37 | 7.32 | H | -42.85 | -72.92 |
| 810 (1909.8) | 3,819.60 | -53.12 | 12.45 | -55.35 | 5.02 | V | -47.92 | -77.99 |
| | 5,729.40 | -51.35 | 12.71 | -47.82 | 6.54 | V | -41.65 | -71.72 |
| | 7,639.20 | -58.74 | 10.87 | -45.83 | 7.78 | H | -42.74 | -72.81 |

- NOTES:**
1. Radiated Spurious Emission Measurements at 3 meters by Substitution Method according to ANSI/TIA/EIA-603-C-2004, Aug. 17, 2004:
 2. The magnitude of spurious emissions attenuated more than 20dB below the limit above 5th Harmonic for all channel.
 3. we have done x, y, z planes in EUT and horizontal and vertical polarization in detecting antenna.

7.8 FREQUENCY STABILITY / VARIATION OF AMBIENT TEMPERATURE

7.8.1 FREQUENCY STABILITY (GSM850)

OPERATING FREQUENCY: 836,600,000 Hz
 CHANNEL: 190
 REFERENCE VOLTAGE: 3.7 VDC
 DEVIATION LIMIT: ± 0.000 25 % or 2.5 ppm

| Voltage (%) | Power (VDC) | Temp. (°C) | Frequency (Hz) | Frequency Error (Hz) | Deviation (%) | ppm |
|----------------|-------------|------------|----------------|----------------------|---------------|-------|
| 100% | 3.700 | +20(Ref) | 836 600 009 | 0 | 0.000 000 | 0.000 |
| 100% | | -30 | 836 600 013 | 3.85 | 0.000 000 | 0.005 |
| 100% | | -20 | 836 600 025 | 15.58 | 0.000 002 | 0.019 |
| 100% | | -10 | 836 600 011 | 1.27 | 0.000 000 | 0.002 |
| 100% | | 0 | 836 600 025 | 15.83 | 0.000 002 | 0.019 |
| 100% | | +10 | 836 600 023 | 13.90 | 0.000 002 | 0.017 |
| 100% | | +30 | 836 600 026 | 16.25 | 0.000 002 | 0.019 |
| 100% | | +40 | 836 600 013 | 3.66 | 0.000 000 | 0.004 |
| 100% | | +50 | 836 600 014 | 4.27 | 0.000 001 | 0.005 |
| 115% | 4.255 | +20 | 836 600 024 | 14.27 | 0.000 002 | 0.017 |
| Batt. Endpoint | 3.400 | +20 | 836 600 023 | 13.89 | 0.000 002 | 0.017 |

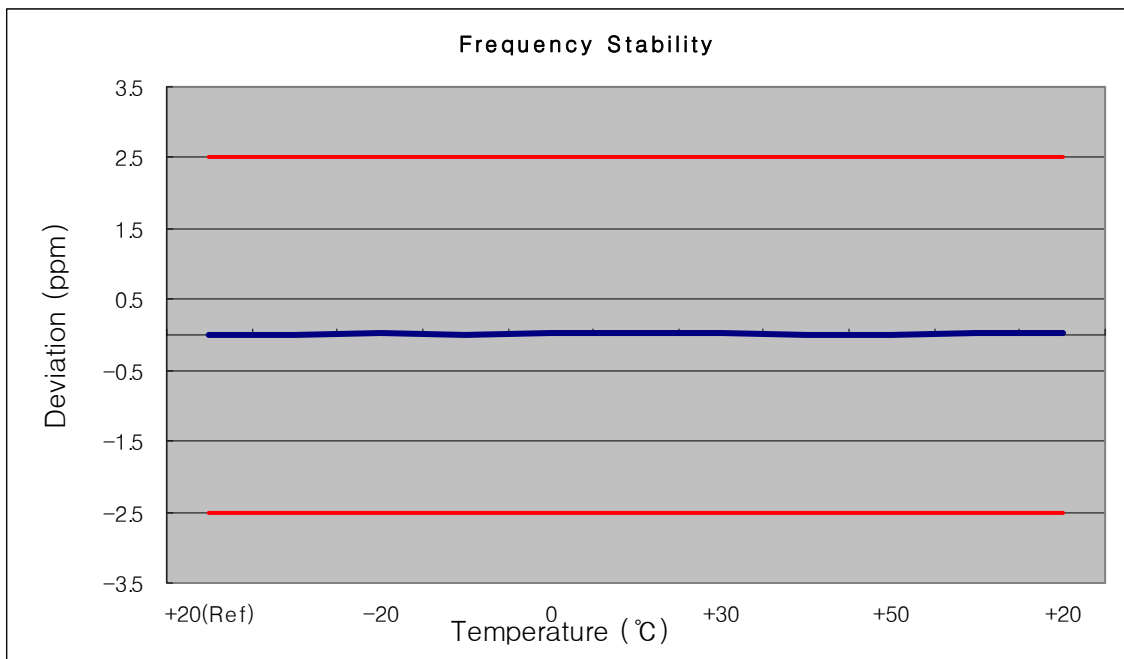

7.8.2 FREQUENCY STABILITY (GSM1900)

OPERATING FREQUENCY: 1880,000,000 Hz
 CHANNEL: 661
 REFERENCE VOLTAGE: 3.7 VDC
 DEVIATION LIM IT: ± 0.000 25 % or 2.5 ppm

| Voltage (%) | Power (VDC) | Temp. (°C) | Frequency (Hz) | Frequency Error (Hz) | Deviation (%) | ppm |
|----------------|-------------|------------|----------------|----------------------|---------------|--------|
| 100% | 3.700 | +20(Ref) | 1880 000 009 | 0 | 0.000 000 | 0.000 |
| 100% | | -30 | 1880 000 018 | 8.96 | 0.000 000 | 0.005 |
| 100% | | -20 | 1880 000 019 | 9.88 | 0.000 001 | 0.005 |
| 100% | | -10 | 1879 999 997 | -11.60 | -0.000 001 | -0.006 |
| 100% | | 0 | 1880 000 003 | -5.92 | 0.000 000 | -0.003 |
| 100% | | +10 | 1880 000 027 | 18.49 | 0.000 001 | 0.010 |
| 100% | | +30 | 1880 000 023 | 14.10 | 0.000 001 | 0.007 |
| 100% | | +40 | 1880 000 000 | -8.86 | 0.000 000 | -0.005 |
| 100% | | +50 | 1880 000 016 | 7.40 | 0.000 000 | 0.004 |
| 115% | 4.255 | +20 | 1880 000 019 | 10.57 | 0.000 001 | 0.006 |
| Batt. Endpoint | 3.400 | +20 | 1880 000 019 | 10.32 | 0.000 001 | 0.005 |

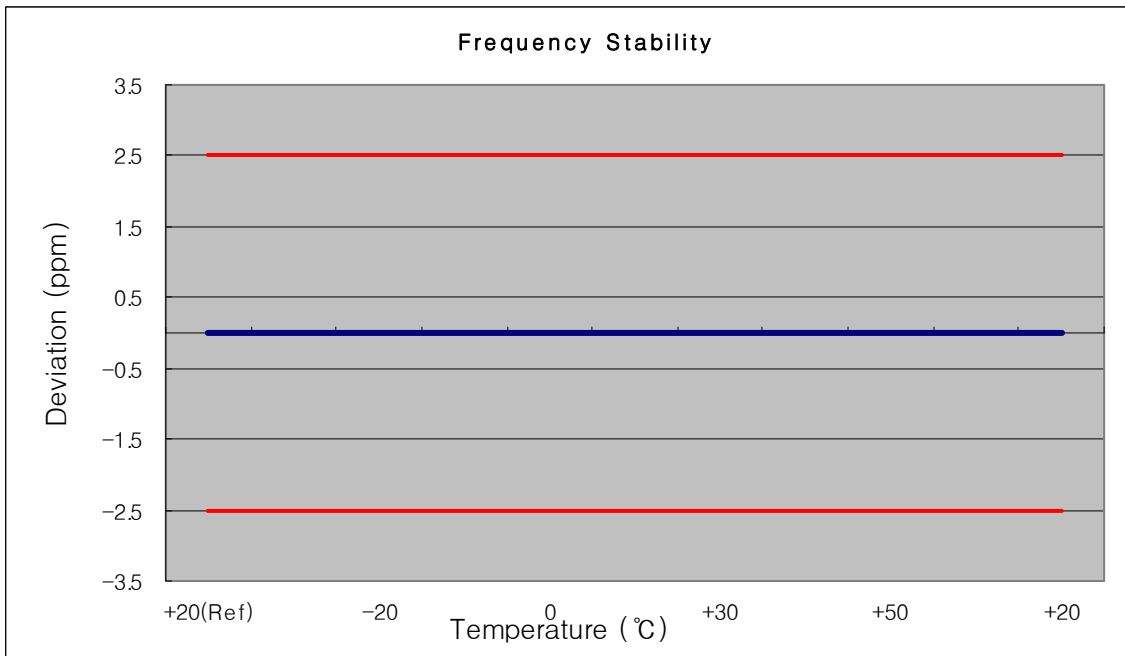

8. TEST PLOTS

| FCC CERTIFICATION REPORT | | | www.hct.co.kr |
|--|---|--|--|
| Test Report No. HCTR1110FR05 | Date of Issue: October 26, 2011 | EUT Type: 850/1900 GSM/GPRS Phone with Bluetooth, WLAN and EDGE Rx Only | FCC ID : A3LGTS5369 |

■ GSM850 MODE (128 CH.) Occupied Bandwidth



■ GSM850 MODE (190 CH.) Occupied Bandwidth



■ GSM850 MODE (251 CH.) Occupied Bandwidth



■ GSM1900 MODE (512 CH.) Occupied Bandwidth

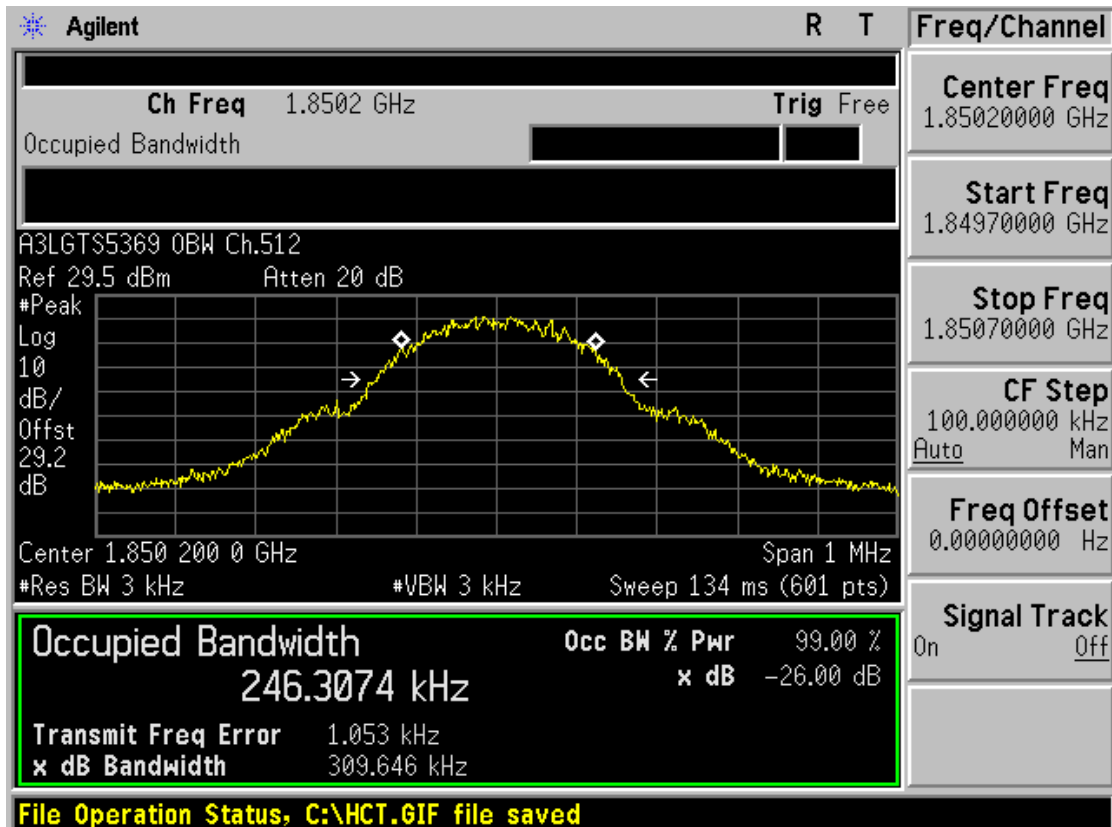

■ GSM1900 MODE (661 CH.) Occupied Bandwidth

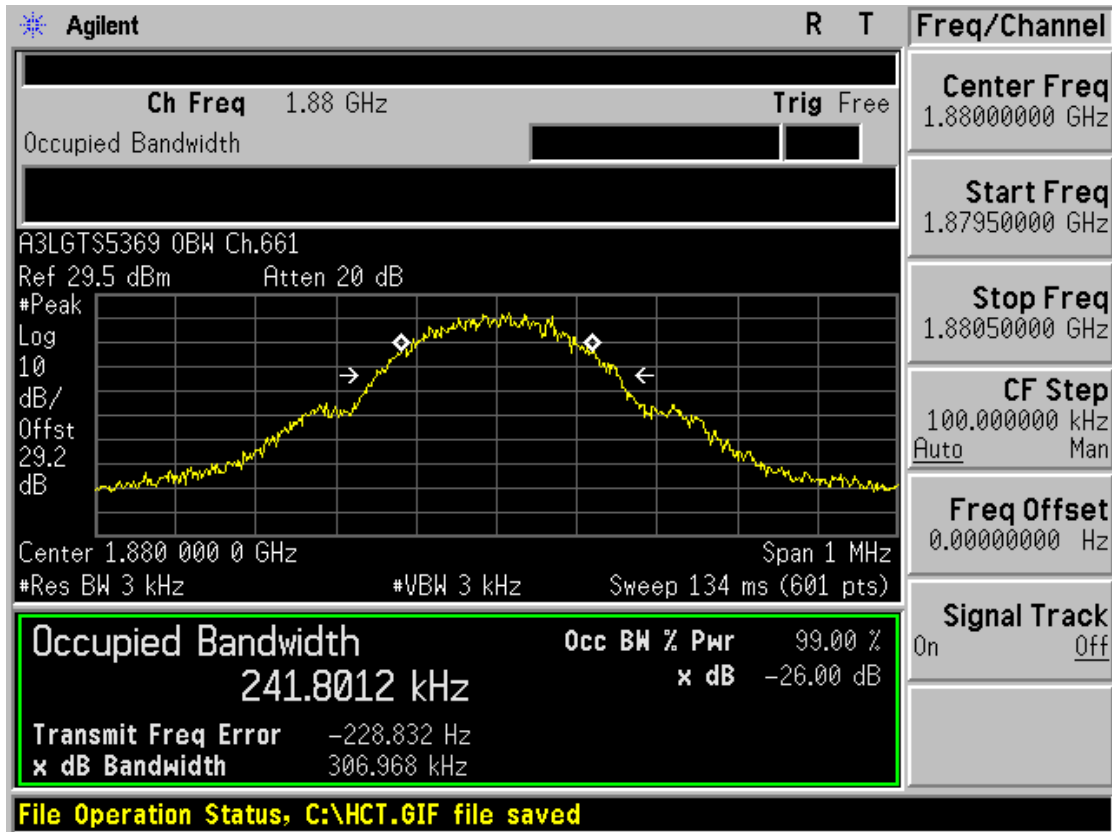

■ GSM1900 MODE (810 CH.) Occupied Bandwidth

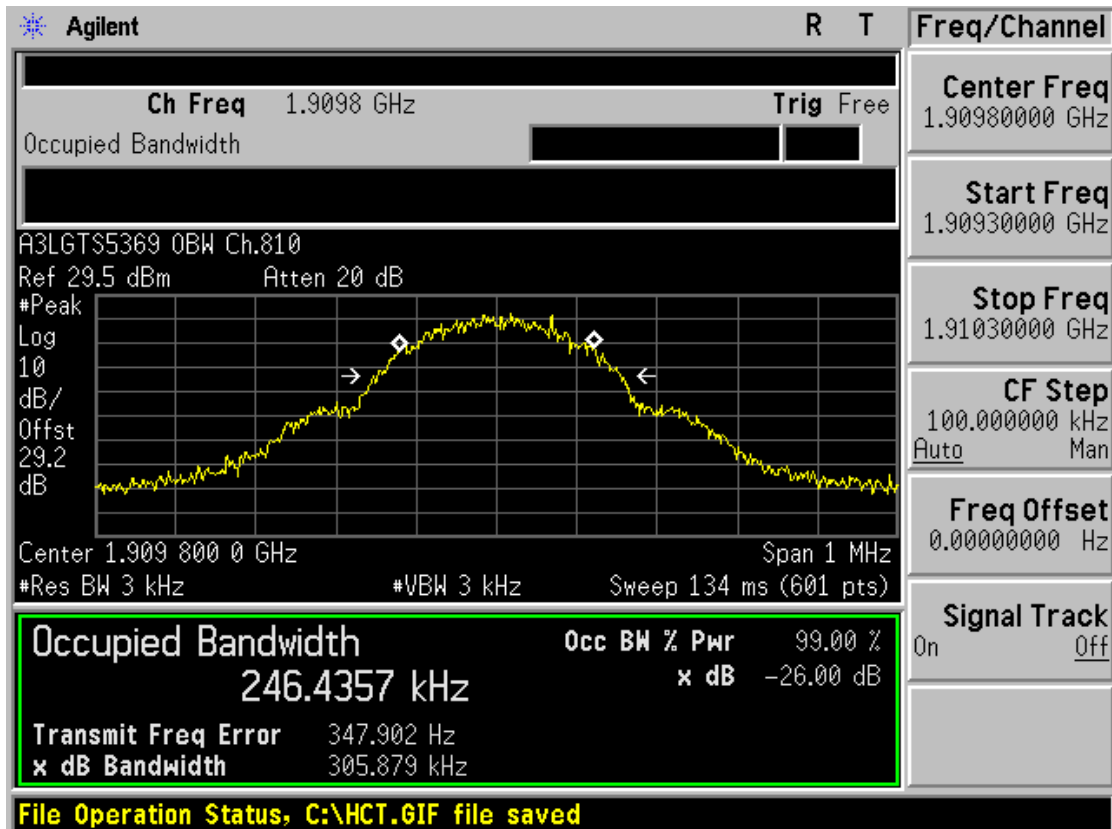

■ GSM1900 MODE (661 CH.) Peak-to-Average Ratio

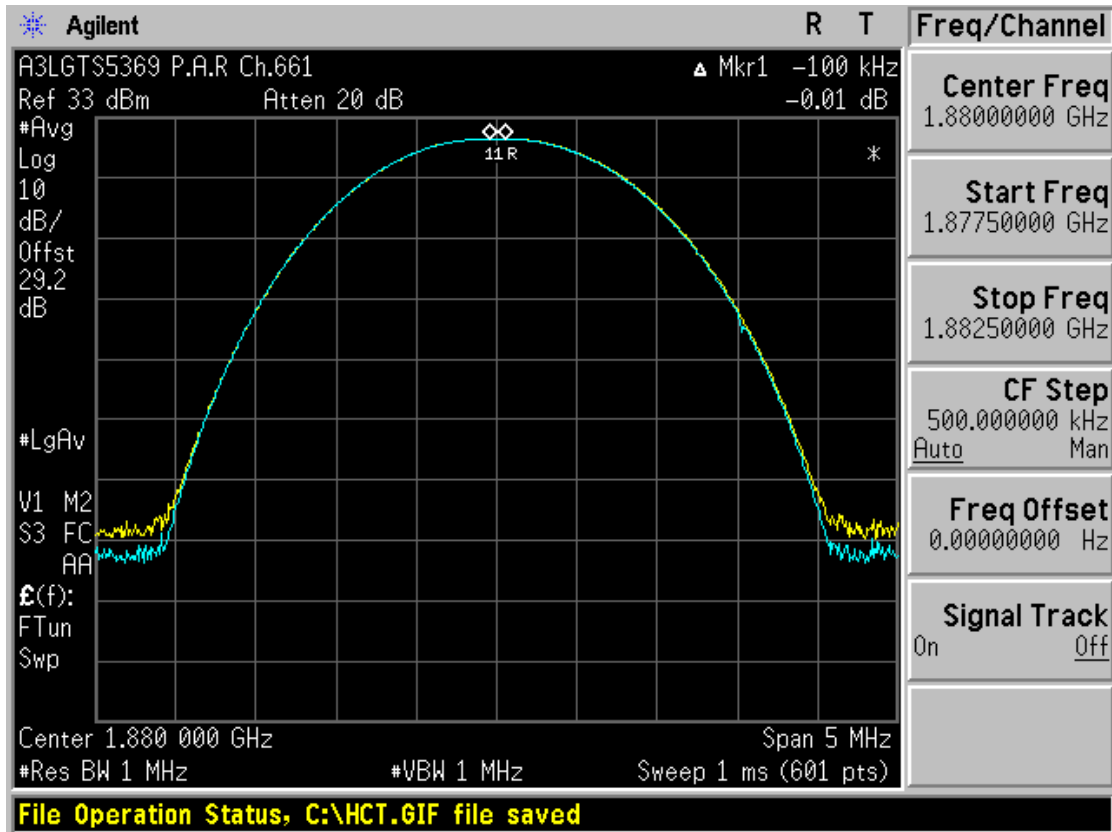

■ GSM850 MODE (128 CH.) Block Edge 1

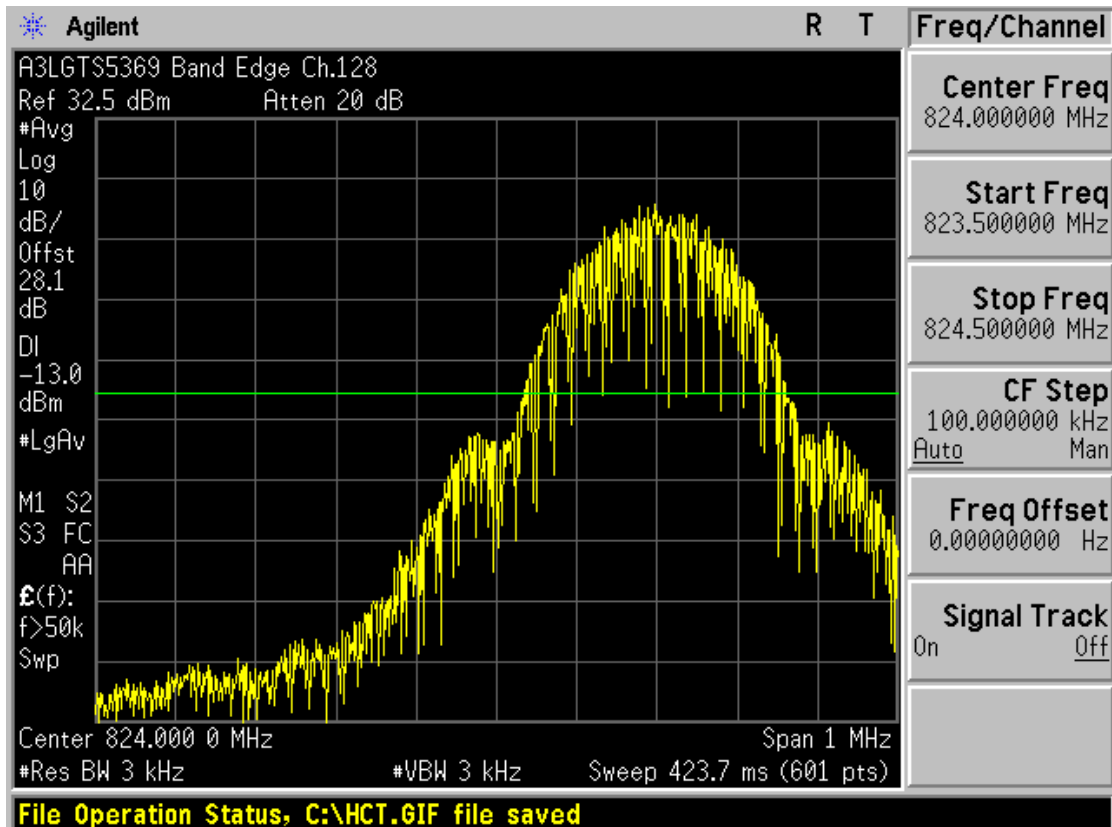

■ GSM850 MODE (128 CH.) Block Edge 2

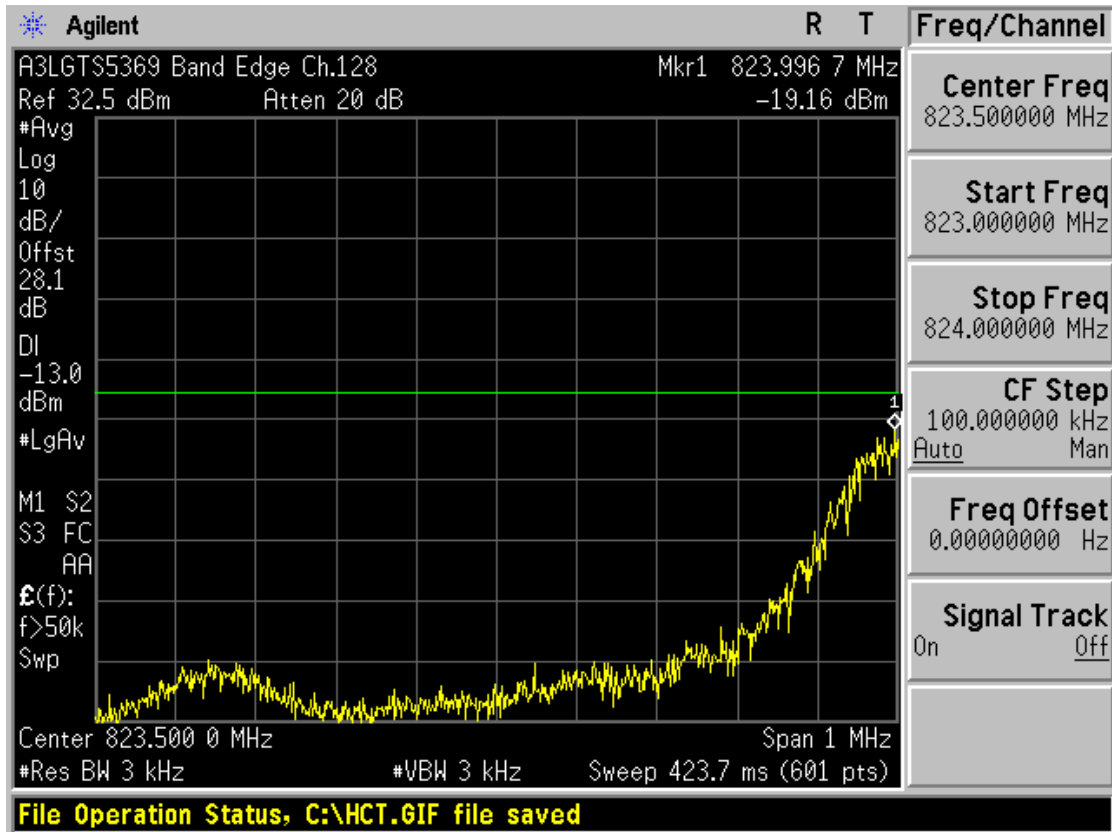

■ GSM850 MODE (251 CH.) Block Edge 1



| FCC CERTIFICATION REPORT | | | www.hct.co.kr |
|---------------------------------|------------------------------------|---|--|
| Test Report No. HCTR1110FR05 | Date of Issue: October 26, 2011 | EUT Type: 850/1900 GSM/GPRS Phone with Bluetooth, WLAN and EDGE Rx Only | FCC ID : A3LGTS5369 |

■ GSM850 MODE (251 CH.) Block Edge 2



■ GSM1900 MODE (512 CH.) Block Edge 1

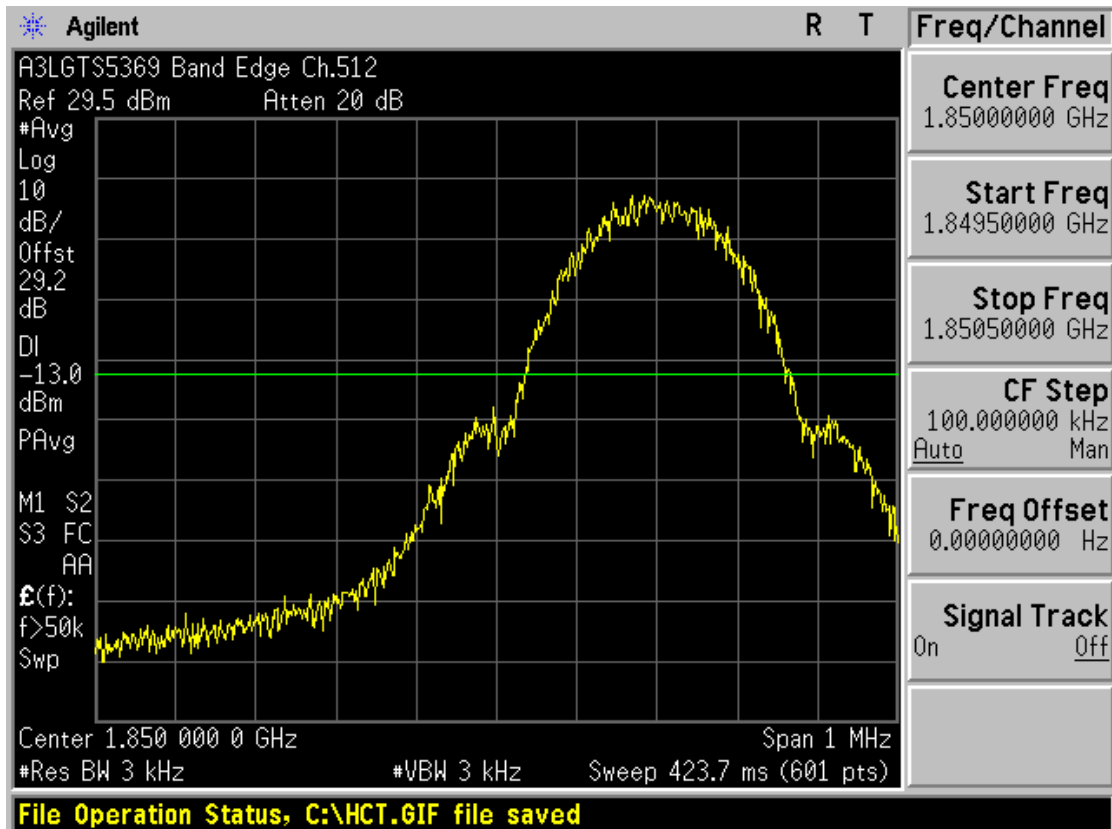

| FCC CERTIFICATION REPORT | | | www.hct.co.kr |
|---------------------------------|------------------------------------|---|--|
| Test Report No. HCTR1110FR05 | Date of Issue: October 26, 2011 | EUT Type: 850/1900 GSM/GPRS Phone with Bluetooth, WLAN and EDGE Rx Only | FCC ID : A3LGT55369 |

■ GSM1900 MODE (512 CH.) Block Edge 2

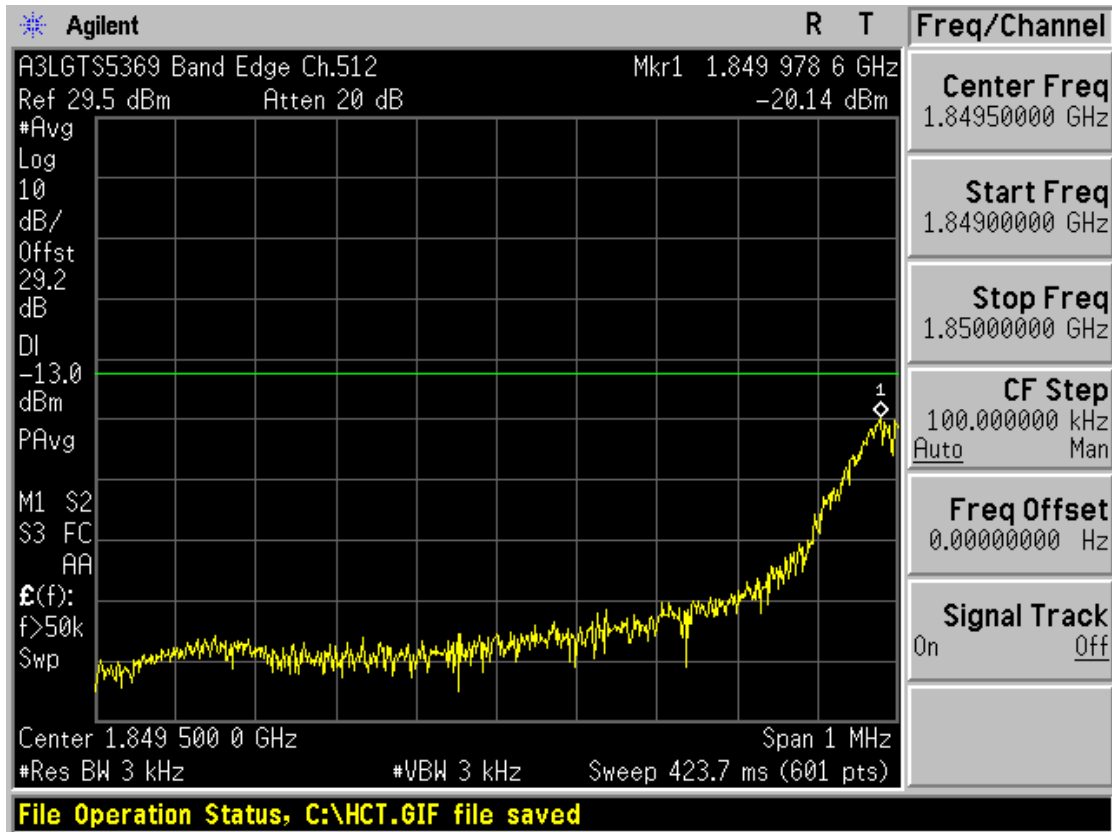

■ GSM1900 MODE (810 CH.) Block Edge 1

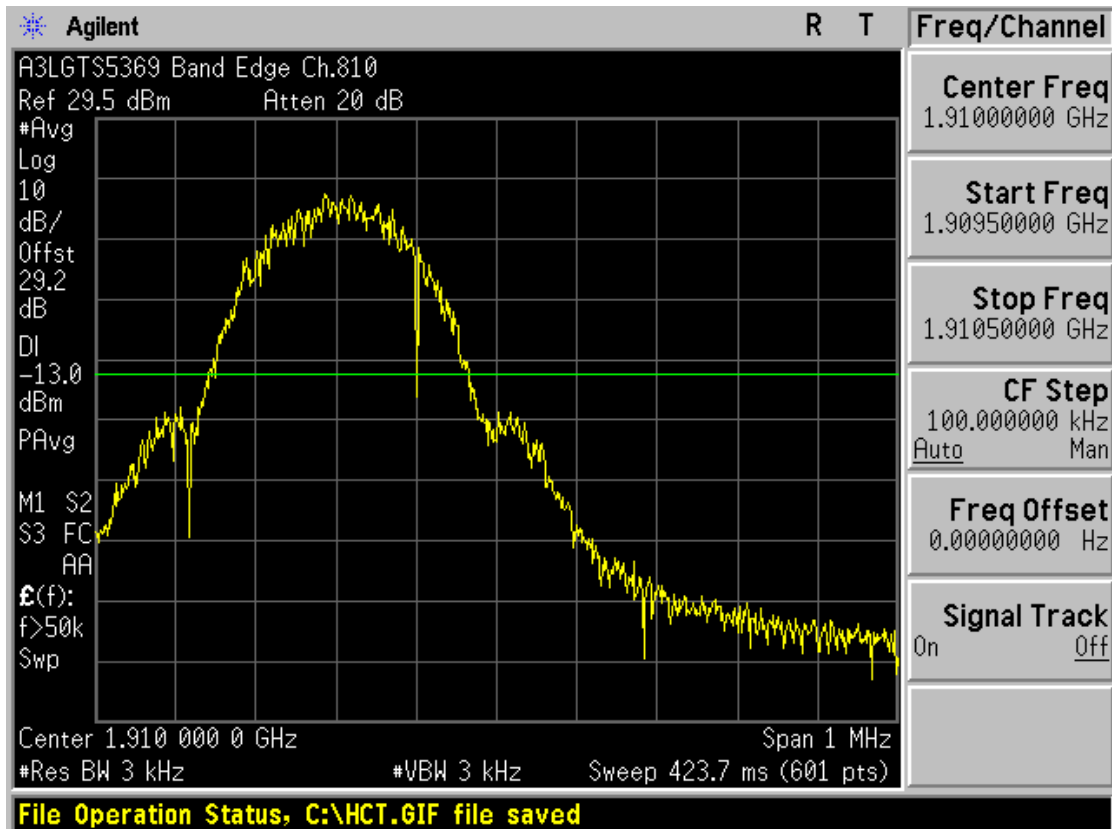

| FCC CERTIFICATION REPORT | | | www.hct.co.kr |
|---------------------------------|------------------------------------|---|--|
| Test Report No. HCTR1110FR05 | Date of Issue: October 26, 2011 | EUT Type: 850/1900 GSM/GPRS Phone with Bluetooth, WLAN and EDGE Rx Only | FCC ID : A3LGTS5369 |

■ GSM1900 MODE (810 CH.) Block Edge 2

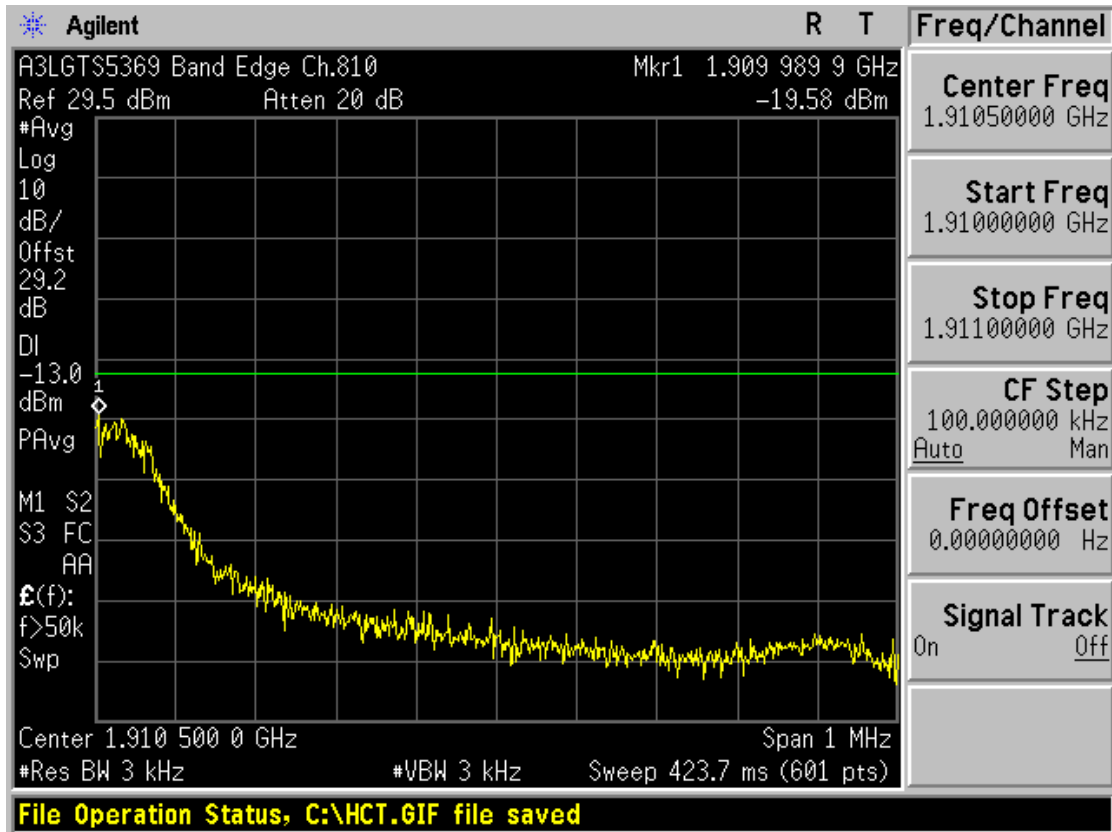

■ GSM850 MODE (128 CH.) Conducted Spurious Emissions1

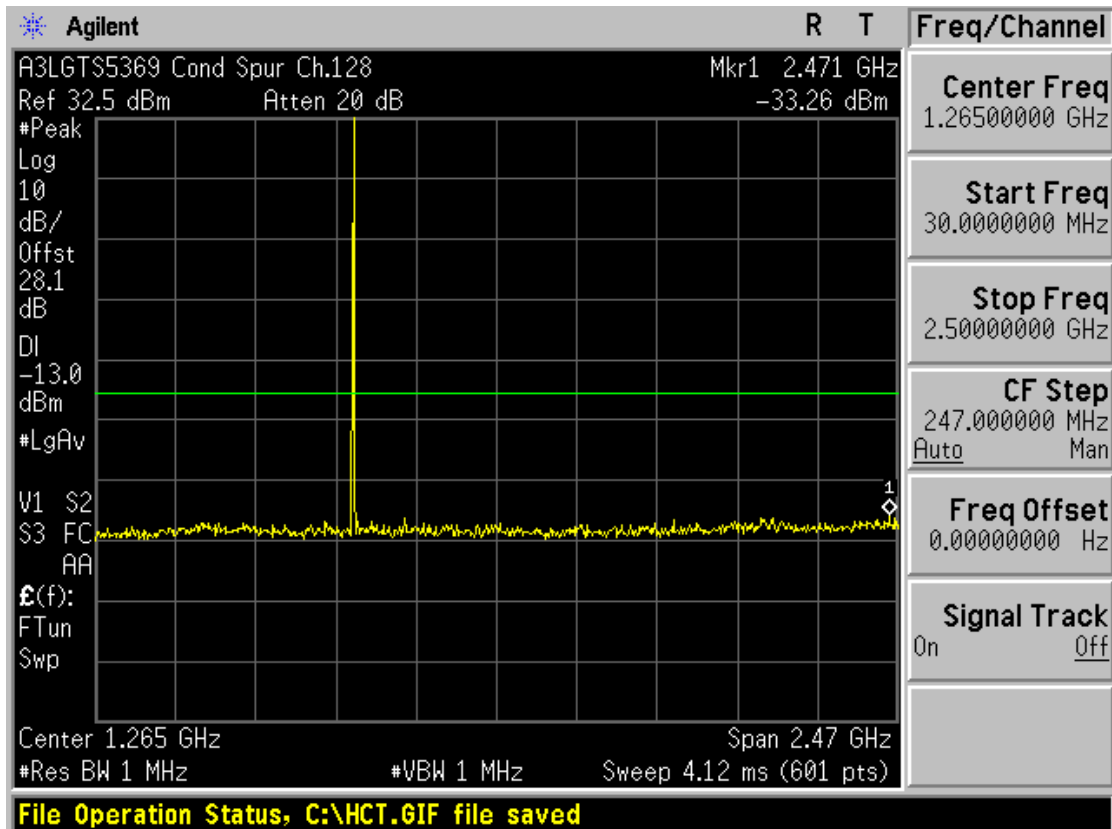

| FCC CERTIFICATION REPORT | | | www.hct.co.kr |
|---------------------------------|------------------------------------|---|--|
| Test Report No. HCTR1110FR05 | Date of Issue: October 26, 2011 | EUT Type: 850/1900 GSM/GPRS Phone with Bluetooth, WLAN and EDGE Rx Only | FCC ID : A3LGT55369 |

■ GSM850 MODE (128 CH.) Conducted Spurious Emissions2

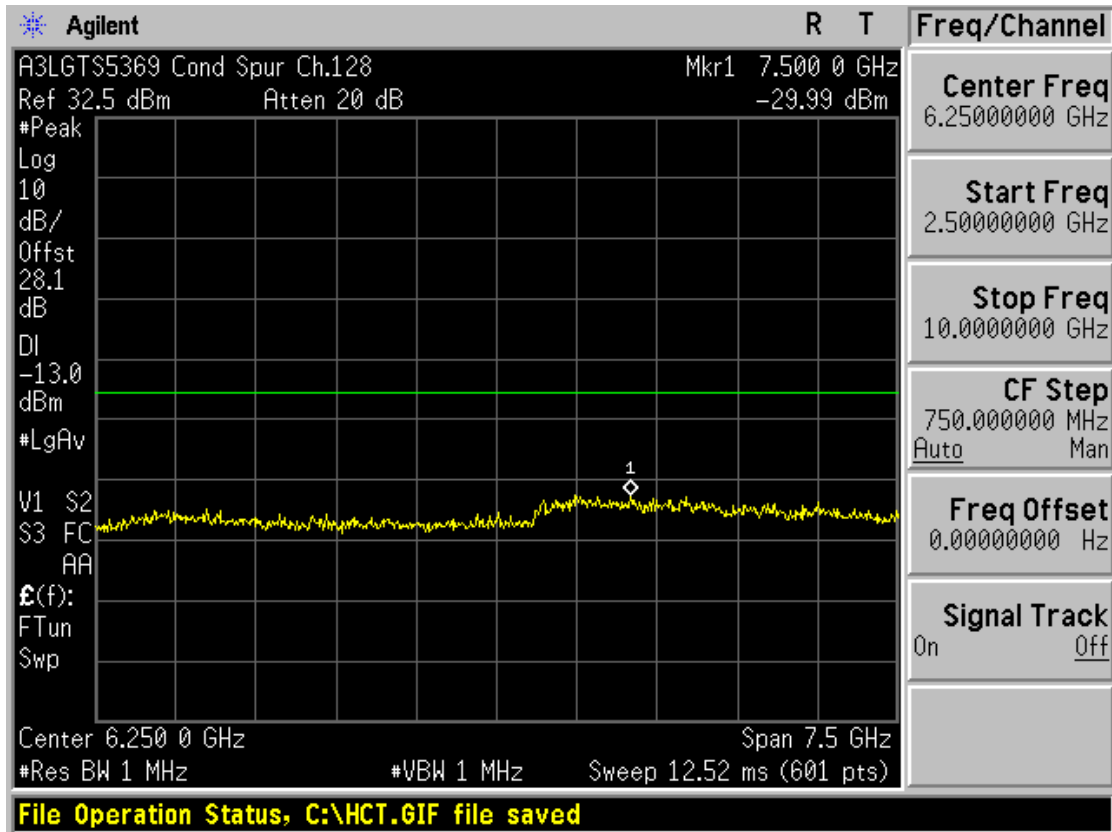

■ GSM850 MODE (190 CH.) Conducted Spurious Emissions1

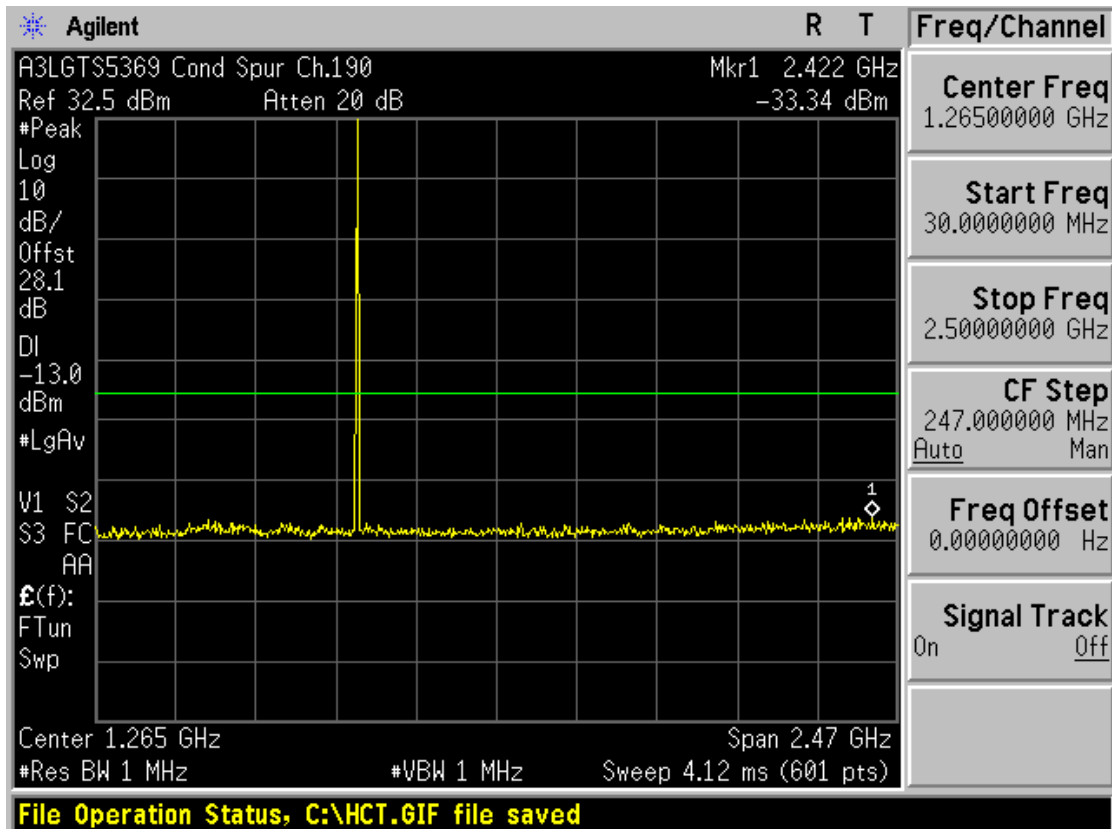

■ GSM850 MODE (190 CH.) Conducted Spurious Emissions2

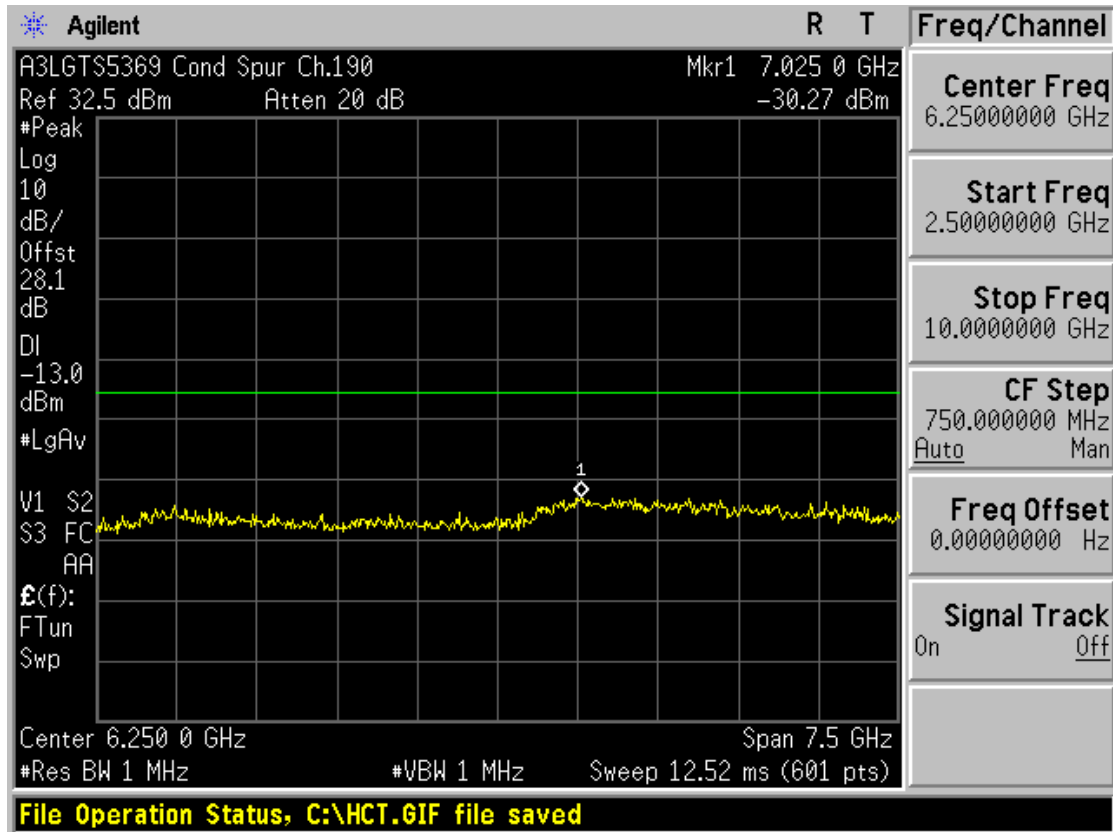

■ GSM850 MODE (251 CH.) Conducted Spurious Emissions1

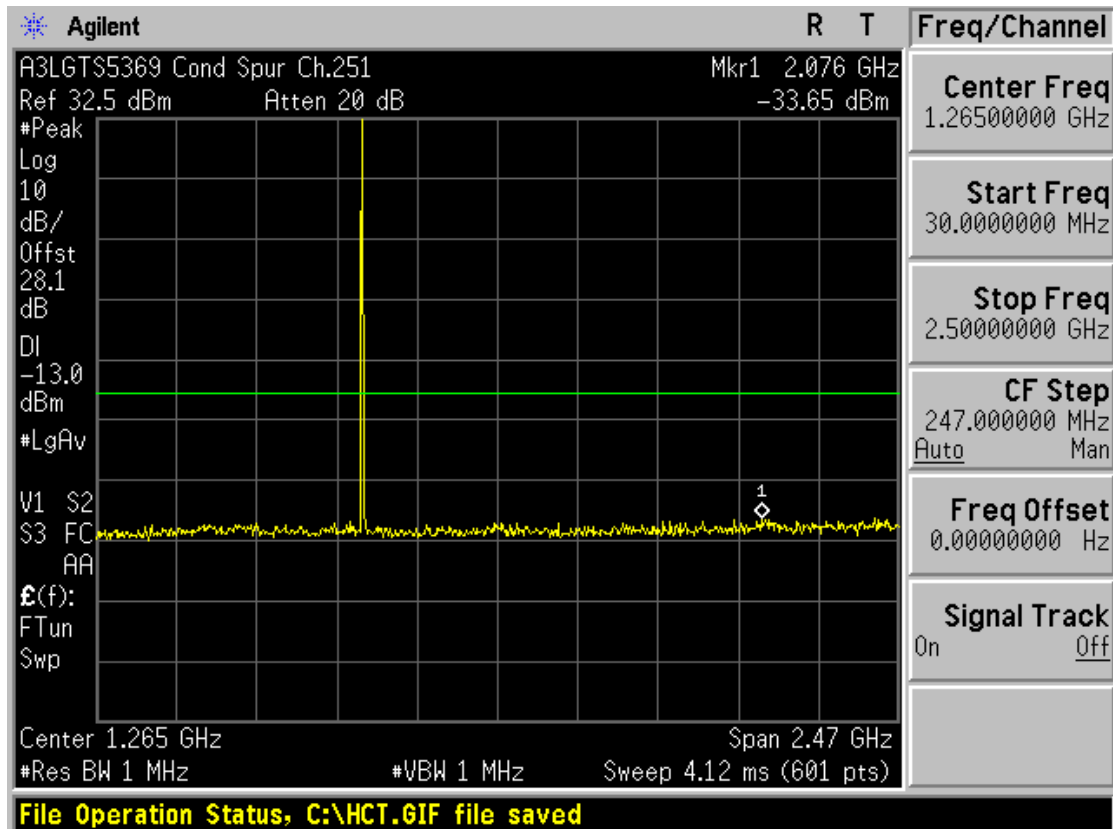

| FCC CERTIFICATION REPORT | | | www.hct.co.kr |
|---------------------------------|------------------------------------|---|--|
| Test Report No. HCTR1110FR05 | Date of Issue: October 26, 2011 | EUT Type: 850/1900 GSM/GPRS Phone with Bluetooth, WLAN and EDGE Rx Only | FCC ID : A3LGT55369 |

■ GSM850 MODE (251 CH.) Conducted Spurious Emissions2

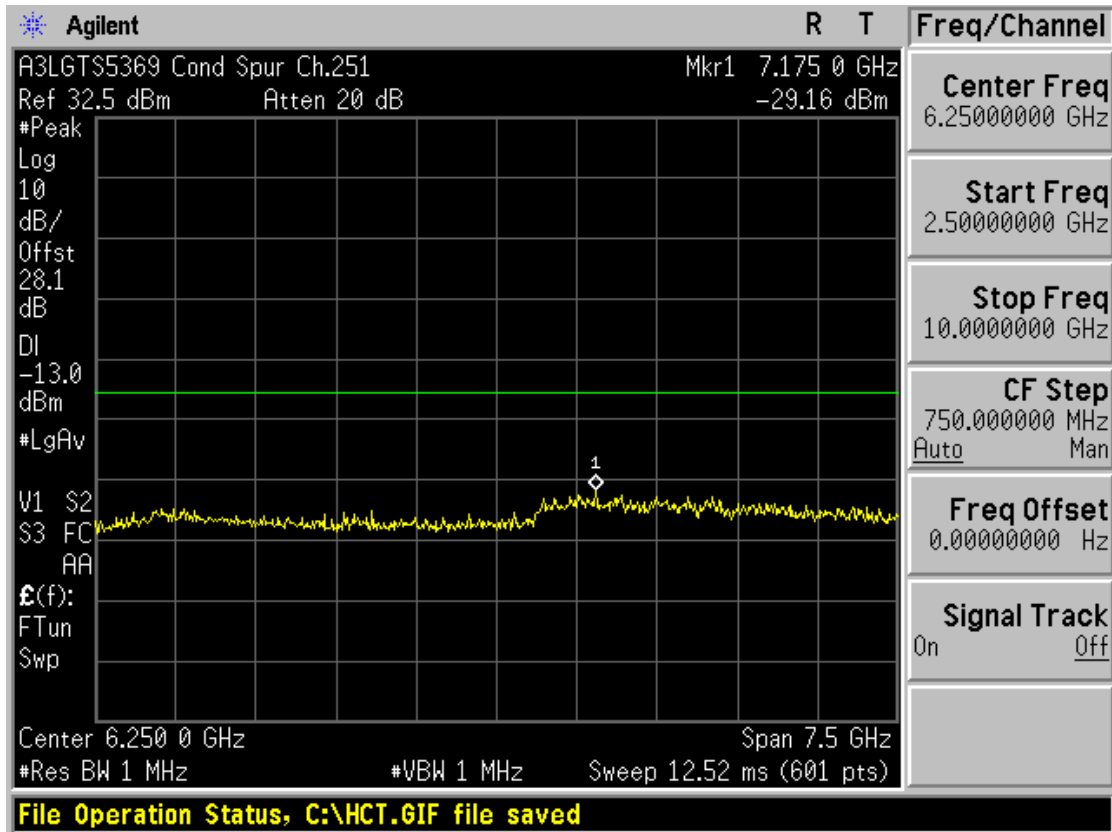

■ GSM1900 MODE (512 CH.) Conducted Spurious Emissions1

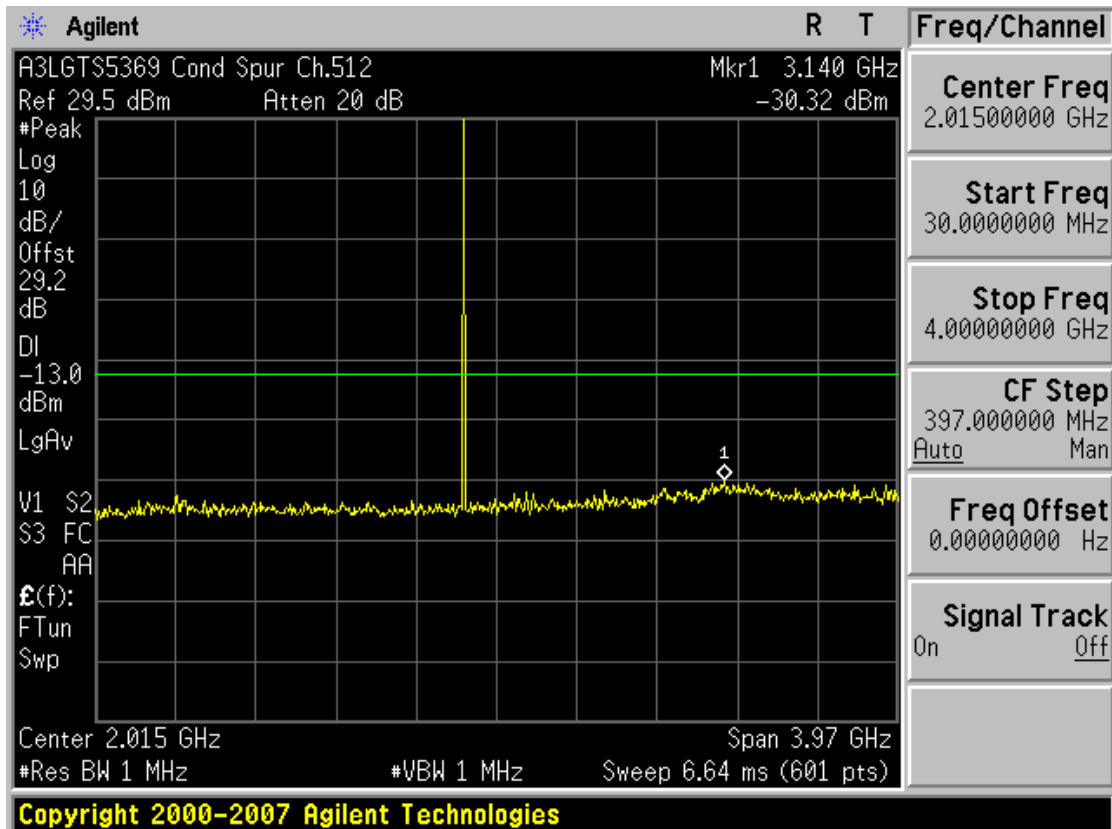

■ GSM1900 MODE (512 CH.) Conducted Spurious Emissions2

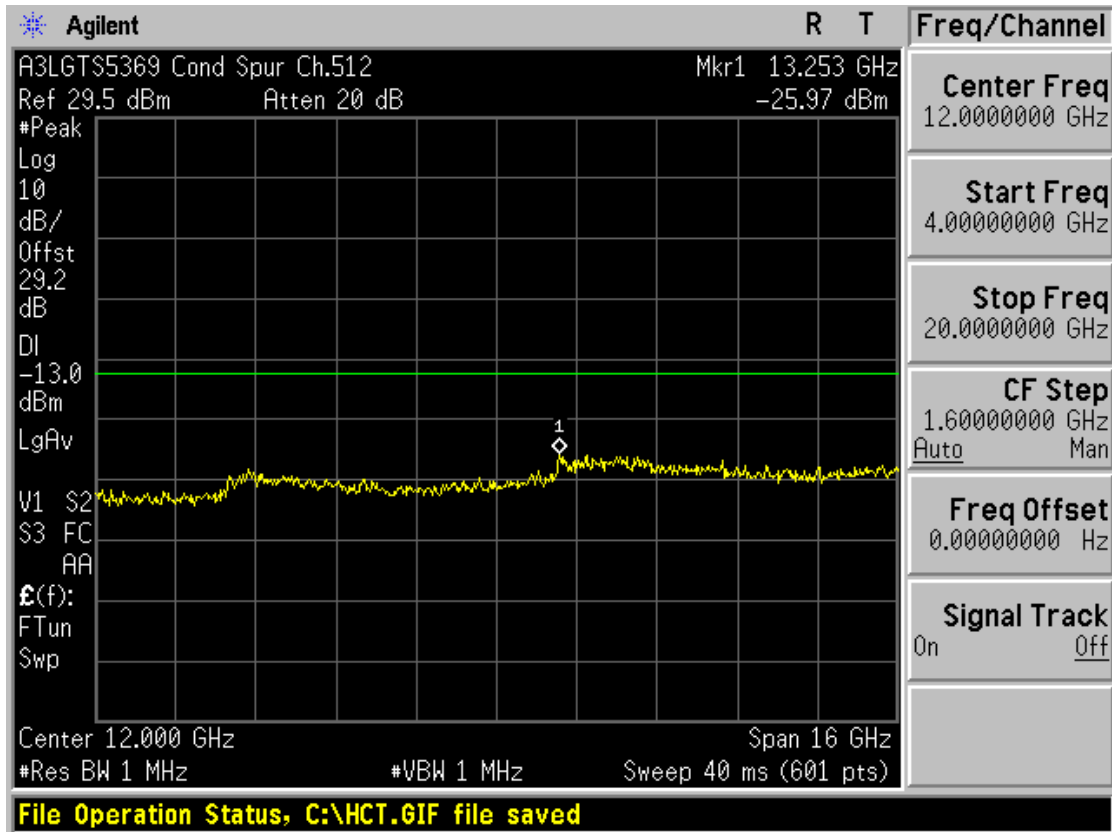

■ GSM1900 MODE (661 CH) Conducted Spurious Emissions1

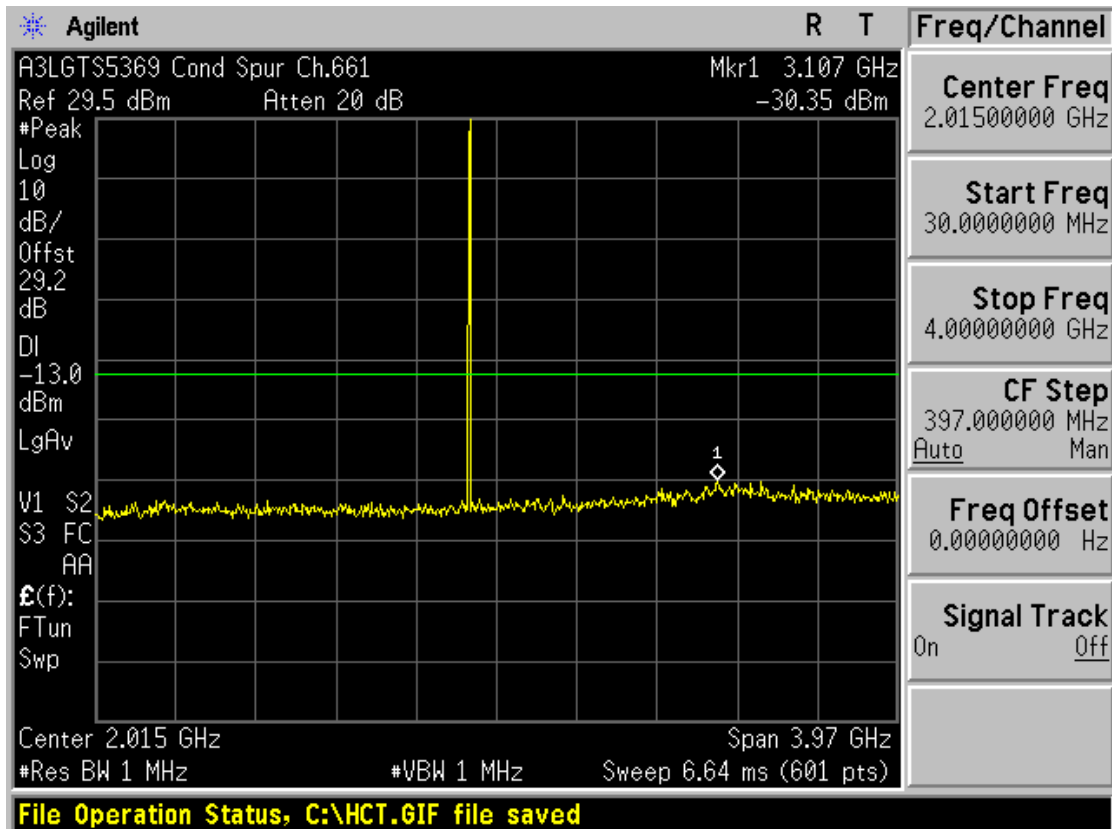

| FCC CERTIFICATION REPORT | | | www.hct.co.kr |
|---------------------------------|------------------------------------|---|--|
| Test Report No. HCTR1110FR05 | Date of Issue: October 26, 2011 | EUT Type: 850/1900 GSM/GPRS Phone with Bluetooth, WLAN and EDGE Rx Only | FCC ID : A3LGT55369 |

■ GSM1900 MODE (661 CH.) Conducted Spurious Emissions2

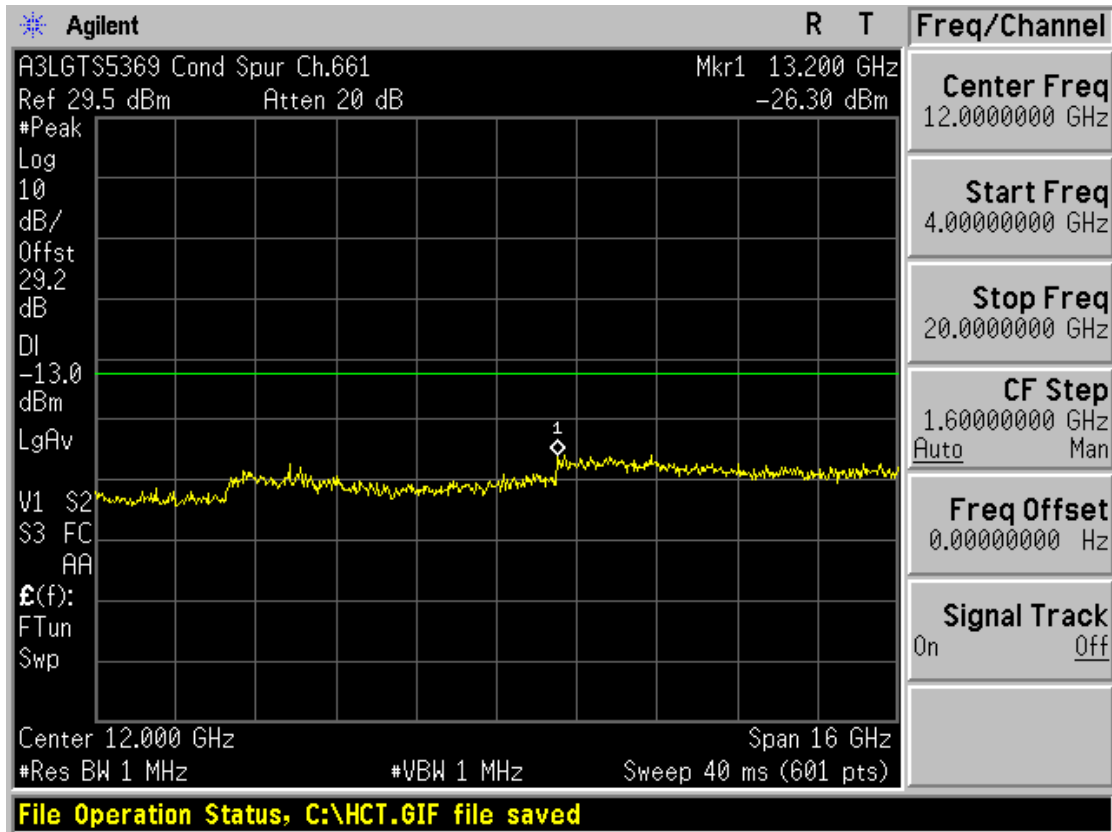

■ GSM1900 MODE (810 CH.) Conducted Spurious Emissions1

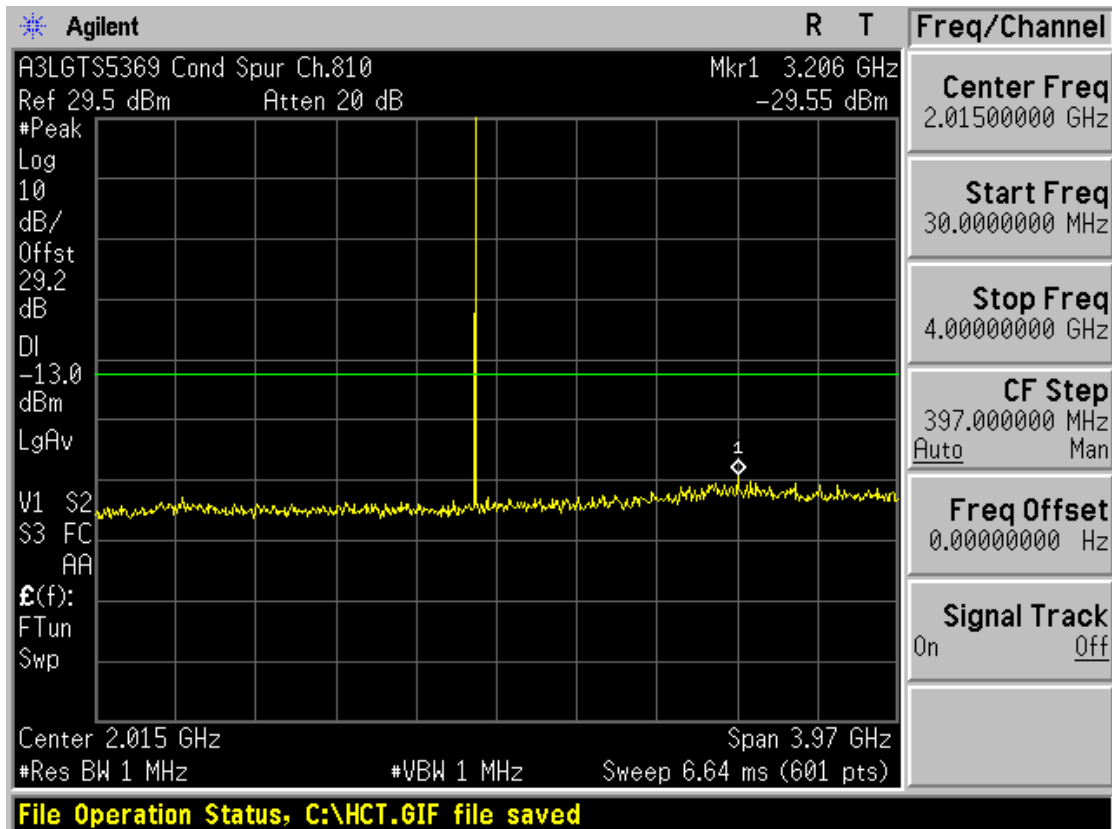

| FCC CERTIFICATION REPORT | | | www.hct.co.kr |
|---------------------------------|------------------------------------|---|--|
| Test Report No. HCTR1110FR05 | Date of Issue: October 26, 2011 | EUT Type: 850/1900 GSM/GPRS Phone with Bluetooth, WLAN and EDGE Rx Only | FCC ID : A3LGT55369 |

■ GSM1900 MODE (810 CH.) Conducted Spurious Emissions2

