



# FCC RF Test Report

**APPLICANT** : Samsung Electronics Co., Ltd.  
**EQUIPMENT** : Mobile phone  
**BRAND NAME** : Samsung  
**MODEL NAME** : GT-S5310C, GT-S5312C  
**MARKETING NAME** : Samsung GALAXY POCKET Neo  
**FCC ID** : A3LGTS5310C  
**STANDARD** : FCC 47 CFR Part 2, 22(H), 24(E)  
**CLASSIFICATION** : PCS Licensed Transmitter Held to Ear (PCE)

The product was received on Apr. 24, 2014 and testing was completed on May 05, 2014. We, SPORTON INTERNATIONAL INC., would like to declare that the tested sample has been evaluated in accordance with the test procedures given in ANSI / TIA / EIA-603-C-2004 and the testing has shown the tested sample to be in compliance with the applicable technical standards.

The test results in this report apply exclusively to the tested model / sample. Without written approval of SPORTON INTERNATIONAL INC., the test report shall not be reproduced except in full.

Reviewed by: Joseph Lin / Supervisor

Approved by: Jones Tsai / Manager



## **SPORTON INTERNATIONAL INC.**

**No. 52, Hwa Ya 1<sup>st</sup> Rd., Hwa Ya Technology Park, Kwei-Shan Hsiang, Tao Yuan Hsien, Taiwan, R.O.C.**

**SPORTON INTERNATIONAL INC.**  
TEL : 886-3-327-3456  
FAX : 886-3-328-4978  
FCC ID : A3LGTS5310C

Page Number : 1 of 88  
Report Issued Date : May 14, 2014  
Report Version : Rev. 01



# TABLE OF CONTENTS

**REVISION HISTORY..... 3**

**SUMMARY OF TEST RESULT ..... 4**

**1 GENERAL DESCRIPTION ..... 5**

    1.1 Applicant..... 5

    1.2 Manufacturer ..... 5

    1.3 Product Feature of Equipment Under Test ..... 5

    1.4 Product Specification subjective to this standard ..... 6

    1.5 Modification of EUT ..... 6

    1.6 Maximum ERP/EIRP Power, Frequency Tolerance, and Emission Designator ..... 7

    1.7 Testing Location ..... 7

    1.8 Applicable Standards ..... 7

**2 TEST CONFIGURATION OF EQUIPMENT UNDER TEST ..... 8**

    2.1 Test Mode..... 8

    2.2 Connection Diagram of Test System ..... 10

    2.3 Support Unit used in test configuration ..... 10

    2.4 Measurement Results Explanation Example ..... 10

**3 TEST RESULT..... 11**

    3.1 Conducted Output Power Measurement..... 11

    3.2 Peak-to-Average Ratio ..... 13

    3.3 Effective Radiated Power and Effective Isotropic Radiated Power Measurement ..... 21

    3.4 99% Occupied Bandwidth and 26dB Bandwidth Measurement..... 25

    3.5 Band Edge Measurement..... 36

    3.6 Conducted Spurious Emission Measurement ..... 40

    3.7 Field Strength of Spurious Radiation Measurement ..... 62

    3.8 Frequency Stability Measurement..... 82

**4 LIST OF MEASURING EQUIPMENT ..... 87**

**5 UNCERTAINTY OF EVALUATION ..... 88**



**SUMMARY OF TEST RESULT**

Report Section	FCC Rule	Description	Limit	Result	Remark
3.1	§2.1046	Conducted Output Power	N/A	PASS	-
3.2	§24.232(d)	Peak-to-Average Ratio	<13 dB	PASS	-
3.3	§22.913(a)(2)	Effective Radiated Power	< 7 Watts	PASS	-
3.3	§24.232(c)	Equivalent Isotropic Radiated Power	< 2 Watts	PASS	-
3.4	§2.1049 §22.917(b) §24.238(b)	Occupied Bandwidth	N/A	PASS	-
3.5	§2.1051 §22.917(a) §24.238(a)	Band Edge Measurement	< $43+10\log_{10}(P[\text{Watts}])$	PASS	-
3.6	§2.1051 §22.917(a) §24.238(a)	Conducted Spurious Emission	< $43+10\log_{10}(P[\text{Watts}])$	PASS	-
3.7	§2.1053 §22.917(a) §24.238(a)	Field Strength of Spurious Radiation	< $43+10\log_{10}(P[\text{Watts}])$	PASS	Under limit 20.36 dB at 13159.000 MHz
3.8	§2.1055 §22.355 §24.235	Frequency Stability for Temperature & Voltage	< 2.5 ppm	PASS	-



# 1 General Description

## 1.1 Applicant

Samsung Electronics Co., Ltd.

129, Samsung-ro, Yeongtong-gu Suwon-si, Gyeonggi-do, 443-742 Korea

## 1.2 Manufacturer

Samsung Electronics Co., Ltd.

129, Samsung-ro, Yeongtong-gu Suwon-si, Gyeonggi-do, 443-742 Korea

## 1.3 Product Feature of Equipment Under Test

Product Feature	
Equipment	Mobile phone
Brand Name	Samsung
Model Name	GT-S5310C, GT-S5312C
Marketing Name	Samsung GALAXY POCKET Neo
FCC ID	A3LGTS5310C
IMEI Code	353680060012087
EUT supports Radios application	GSM/EGPRS/WCDMA/HSPA WLAN 11b/g/n (HT20) Bluetooth v4.0 EDR/LE
HW Version	REV1.0
SW Version	S5310C.001
EUT Stage	Production Unit

**Remark:** The above EUT's information was declared by manufacturer. Please refer to the specifications or user's manual for more detailed description.

### 1.4 Product Specification subjective to this standard

Product Specification subjective to this standard	
<b>Tx Frequency</b>	GSM850: 824.2 MHz ~ 848.8 MHz GSM1900: 1850.2 MHz ~ 1909.8MHz WCDMA Band V: 826.4 MHz ~ 846.6 MHz
<b>Rx Frequency</b>	GSM850: 869.2 MHz ~ 893.8 MHz GSM1900: 1930.2 MHz ~ 1989.8 MHz WCDMA Band V: 871.4 MHz ~ 891.6 MHz
<b>Maximum Output Power to Antenna</b>	GSM850 : 30.84 dBm GSM1900 : 29.36 dBm WCDMA Band V : 22.48 dBm
<b>Antenna Type</b>	Internal Antenna
<b>Type of Modulation</b>	GSM: GMSK GPRS: GMSK EDGE: GMSK / 8PSK (Rx only) WCDMA: QPSK (Uplink) HSDPA: QPSK (Uplink) HSUPA: QPSK (Uplink)

### 1.5 Modification of EUT

No modifications are made to the EUT during all test items.

### 1.6 Maximum ERP/EIRP Power, Frequency Tolerance, and Emission Designator

FCC Rule	System	Type of Modulation	Maximum ERP/EIRP (W)	Frequency Tolerance (ppm)	Emission Designator
Part 22	GSM850 GSM	GMSK	0.33	0.04 ppm	250KGXW
Part 22	WCDMA Band V RMC 12.2Kbps	QPSK	0.03	0.02 ppm	4M12F9W
Part 24	GSM1900 GSM	GMSK	1.05	0.02 ppm	250KGXW

### 1.7 Testing Location

Sporton Lab is accredited to ISO 17025 by Taiwan Accreditation Foundation (TAF code : 1190) and the FCC designation No. TW1022 under the FCC 2.948(e) by Mutual Recognition Agreement (MRA) in FCC Test.

<b>Test Site</b>	SPORTON INTERNATIONAL INC.	
<b>Test Site Location</b>	No. 52, Hwa Ya 1 <sup>st</sup> Rd., Hwa Ya Technology Park, Kwei-Shan Hsiang, Tao Yuan Hsien, Taiwan, R.O.C. TEL: +886-3-327-3456 FAX: +886-3-328-4978	
<b>Test Site No.</b>	<b>Sporton Site No.</b>	
	TH02-HY	03CH07-HY

### 1.8 Applicable Standards

According to the specifications of the manufacturer, the EUT must comply with the requirements of the following standards:

- FCC 47 CFR Part 2, 22(H), 24(E)
- ANSI / TIA / EIA-603-C-2004
- FCC KDB 971168 D01 Power Meas. License Digital Systems v02r01

**Remark:** All test items were verified and recorded according to the standards and without any deviation during the test.

## 2 Test Configuration of Equipment Under Test

### 2.1 Test Mode

Antenna port conducted and radiated test items were performed according to KDB 971168 D01 Power Meas. License Digital Systems v02r01 with maximum output power.

Radiated measurements were performed with rotating EUT in different three orthogonal test planes to find the maximum emission.

Radiated emissions were investigated as following frequency range:

1. 30 MHz to 9000 MHz for GSM850 and WCDMA Band V.
2. 30 MHz to 19000 MHz for GSM1900.

Test Modes		
Band	Radiated TCs	Conducted TCs
GSM 850	■ GSM Link	■ GSM Link
GSM 1900	■ GSM Link	■ GSM Link
WCDMA Band V	■ RMC 12.2Kbps Link	■ RMC 12.2Kbps Link

**Note:** The maximum power levels are chosen to test as the worst case configuration as follows:

GSM multi-slot class 8 mode for GMSK modulation,

RMC 12.2Kbps mode for WCDMA band V, only these modes were used for all tests.



Conducted Power Measurement Results:

Conducted Power (*Unit: dBm)						
Band	GSM850			GSM1900		
Channel	128	189	251	512	661	810
Frequency	824.2	836.4	848.8	1850.2	1880.0	1909.8
GSM	30.76	30.84	30.82	29.17	29.28	29.36
GPRS class 8	30.81	30.83	30.83	29.21	29.25	29.35
GPRS class 10	28.01	28.07	28.05	26.28	26.30	26.42
GPRS class 11	26.22	26.32	26.30	24.47	24.55	24.65
GPRS class 12	24.68	24.81	24.76	23.21	23.26	23.27

Conducted Power (*Unit: dBm)			
Band	WCDMA Band V		
Channel	4132	4182	4233
Frequency	826.4	836.4	846.6
RMC 12.2K	22.48	22.17	22.20
HSDPA Subtest-1	22.14	22.01	22.08
HSDPA Subtest-2	22.04	21.79	21.90
HSDPA Subtest-3	22.03	21.79	21.91
HSDPA Subtest-4	22.05	21.76	21.80
HSUPA Subtest-1	20.06	19.81	19.88
HSUPA Subtest-2	17.98	17.88	17.92
HSUPA Subtest-3	19.33	19.21	19.25
HSUPA Subtest-4	18.90	18.71	18.75
HSUPA Subtest-5	20.59	20.48	20.54

## 2.2 Connection Diagram of Test System

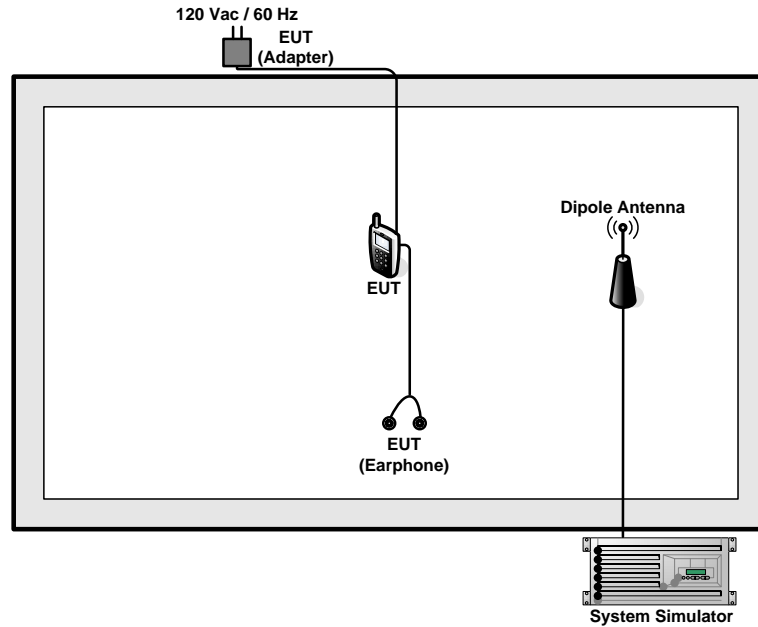

## 2.3 Support Unit used in test configuration

Item	Equipment	Trade Name	Model No.	FCC ID	Data Cable	Power Cord
1.	System Simulator	R&S	CMU 200	N/A	N/A	Unshielded, 1.8 m

## 2.4 Measurement Results Explanation Example

For all conducted test items:

The offset level is set in the spectrum analyzer to compensate the RF cable loss and attenuator factor between RF conducted output port and spectrum analyzer. With the offset compensation, the spectrum analyzer reading level will be exactly the RF output level.

The spectrum analyzer offset is derived from RF cable loss and attenuator factor.

*Offset = RF cable loss + attenuator factor.*

The following shows an offset computation example with RF cable loss 4.2 dB and a 10dB attenuator.

Example :

$$\begin{aligned} \text{Offset(dB)} &= \text{RF cable loss(dB)} + \text{attenuator factor(dB)}. \\ &= 4.2 + 10 = 14.2 \text{ (dB)} \end{aligned}$$

### 3 Test Result

#### 3.1 Conducted Output Power Measurement

##### 3.1.1 Description of the Conducted Output Power Measurement

A system simulator was used to establish communication with the EUT. Its parameters were set to enforce EUT transmitting at the maximum power. The measured power in the radio frequency on the transmitter output terminals shall be reported.

##### 3.1.2 Measuring Instruments

The measuring equipment is listed in the section 4 of this test report.

##### 3.1.3 Test Procedures

1. The transmitter output port was connected to the system simulator.
2. Set EUT at maximum power through system simulator.
3. Select lowest, middle, and highest channels for each band and different modulation.
4. Measure the maximum burst average power for GSM and maximum average power for other modulation signal.

##### 3.1.4 Test Setup

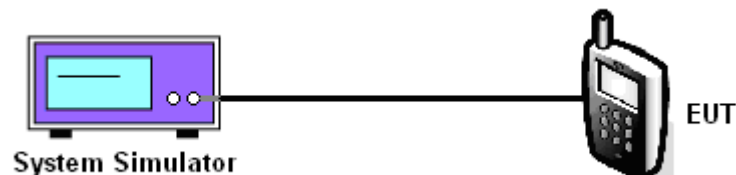



### 3.1.5 Test Result of Conducted Output Power

Cellular Band						
Modes	GSM850 (GSM)			WCDMA Band V (RMC 12.2Kbps)		
Channel	128 (Low)	189 (Mid)	251 (High)	4132 (Low)	4182 (Mid)	4233 (High)
Frequency (MHz)	824.2	836.4	848.8	826.4	836.4	846.6
Conducted Power (dBm)	30.76	30.84	30.82	29.17	29.28	29.36

PCS Band			
Modes	GSM1900 (GSM)		
Channel	512 (Low)	661 (Mid)	810 (High)
Frequency (MHz)	1850.2	1880	1909.8
Conducted Power (dBm)	22.48	22.17	22.20

**Note:** maximum burst average power for GSM, and maximum average power for WCDMA.

## 3.2 Peak-to-Average Ratio

### 3.2.1 Description of the PAR Measurement

The peak-to-average ratio (PAR) of the transmission may not exceed 13 dB.

### 3.2.2 Measuring Instruments

The measuring equipment is listed in the section 4 of this test report.

### 3.2.3 Test Procedures

1. The EUT was connected to spectrum analyzer and system simulator via a power divider.
2. Set EUT to transmit at maximum output power.
3. When the duty cycle is less than 98%, then signal gating will be implemented on the spectrum analyzer by triggering from the system simulator.
4. Set the CCDF (Complementary Cumulative Distribution Function) option of the spectrum analyzer.  
Record the maximum PAPR level associated with a probability of 0.1%.

### 3.2.4 Test Setup

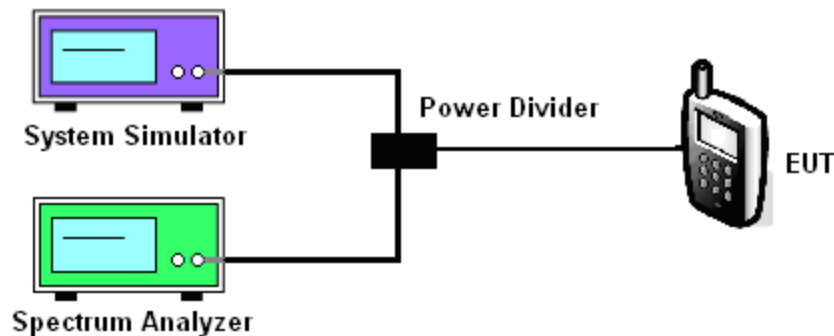



3.2.5 Test Result of Peak-to-Average Ratio

Cellular Band						
Modes	GSM850 (GSM)			WCDMA Band V (RMC 12.2Kbps)		
Channel	128 (Low)	189 (Mid)	251 (High)	4132 (Low)	4182 (Mid)	4233 (High)
Frequency (MHz)	824.2	836.4	848.8	826.4	836.4	846.6
Peak-to-Average Ratio (dB)	0.20	0.20	0.20	3.00	3.24	3.04

PCS Band			
Modes	GSM1900 (GSM)		
Channel	512 (Low)	661 (Mid)	810 (High)
Frequency (MHz)	1850.2	1880	1909.8
Peak-to-Average Ratio (dB)	0.16	0.24	0.20



### 3.2.6 Test Result (Plots) of Peak-to-Average Ratio

<b>Band :</b>	GSM 850	<b>Test Mode :</b>	GSM Link (GMSK)
---------------	---------	--------------------	-----------------

#### Peak-to-Average Ratio on Channel 128 (824.2 MHz)

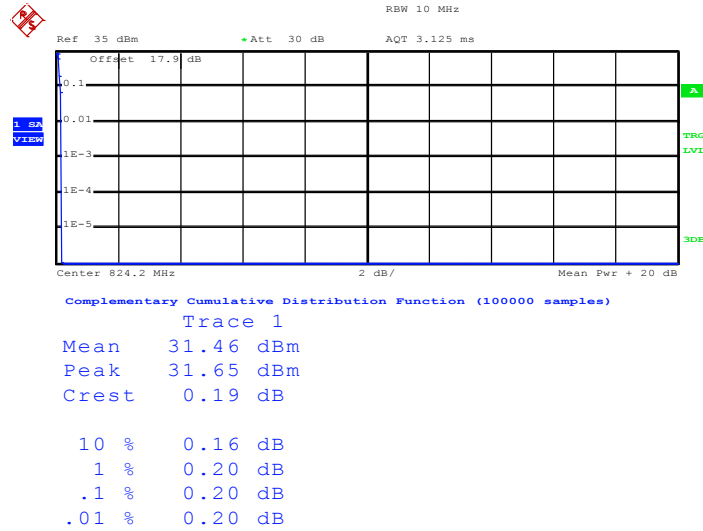

Date: 29.APR.2014 13:53:17

#### Peak-to-Average Ratio on Channel 189 (836.4 MHz)

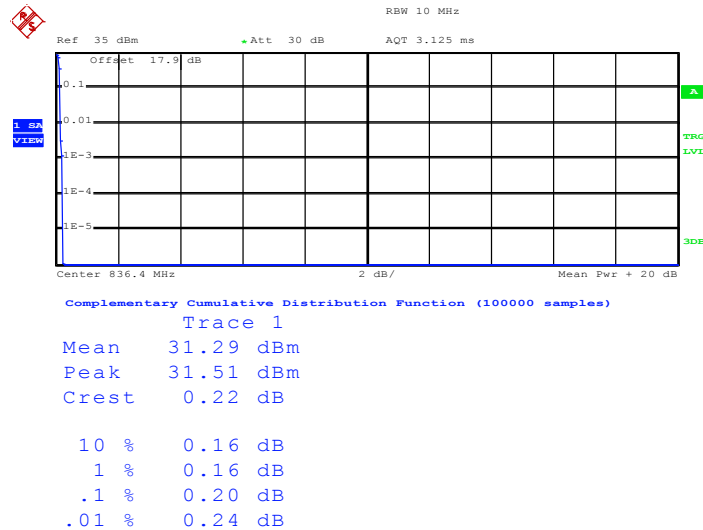

Date: 29.APR.2014 13:53:55



Peak-to-Average Ratio on Channel 251 (848.8 MHz)

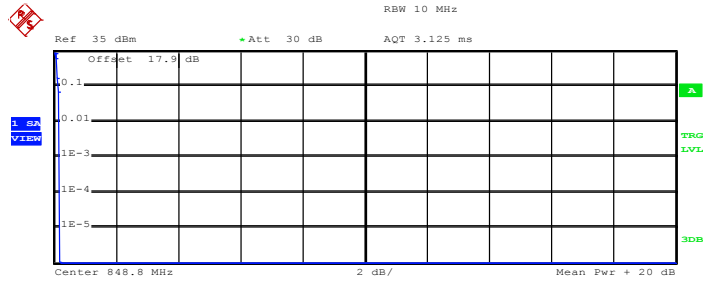

Complementary Cumulative Distribution Function (100000 samples)

Trace 1  
 Mean    31.46 dBm  
 Peak    31.65 dBm  
 Crest    0.19 dB

10 %    0.16 dB  
 1 %    0.20 dB  
 .1 %    0.20 dB  
 .01 %    0.20 dB

Date: 29.APR.2014 13:54:27



<b>Band :</b>	GSM 1900	<b>Test Mode :</b>	GSM Link (GMSK)
---------------	----------	--------------------	-----------------

**Peak-to-Average Ratio on Channel 512 (1850.2 MHz)**

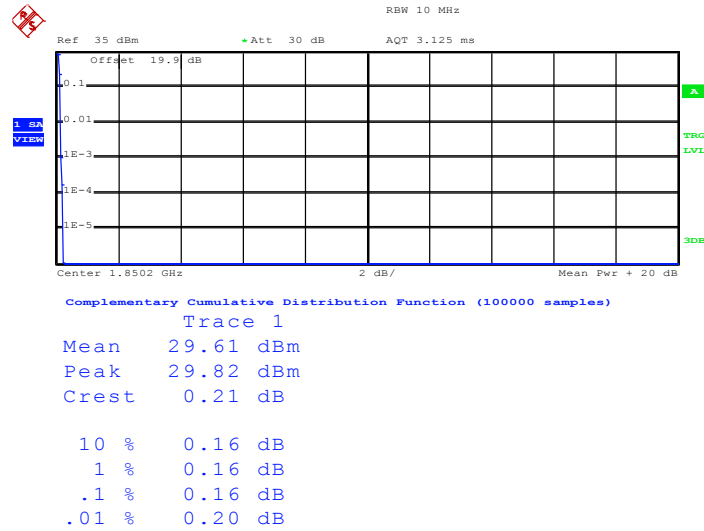

Date: 29.APR.2014 19:01:33

**Peak-to-Average Ratio on Channel 661 (1880.0 MHz)**

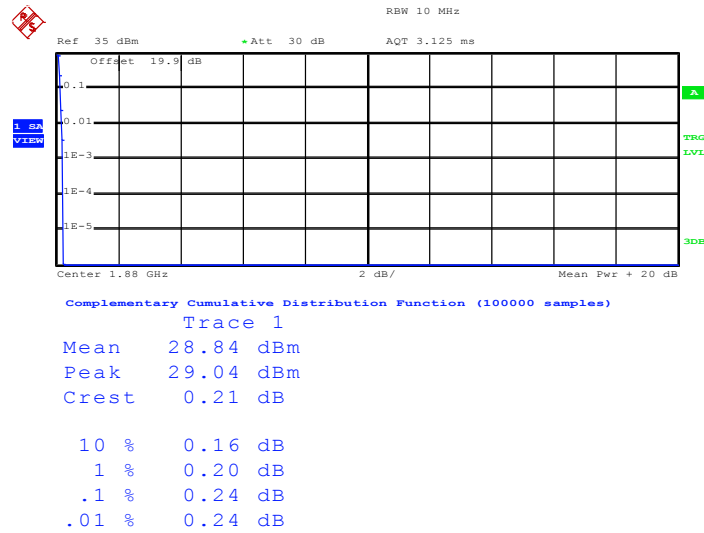

Date: 29.APR.2014 19:02:01



Peak-to-Average Ratio on Channel 810 (1909.8 MHz)

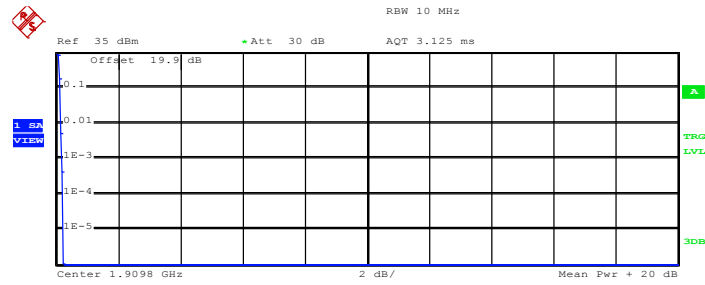

Complementary Cumulative Distribution Function (100000 samples)

Trace 1

Mean	29.62 dBm
Peak	29.82 dBm
Crest	0.20 dB
10 %	0.12 dB
1 %	0.16 dB
.1 %	0.20 dB
.01 %	0.24 dB

Date: 29.APR.2014 19:02:42



<b>Band :</b>	WCDMA Band V	<b>Test Mode :</b>	RMC 12.2Kbps Link (QPSK)
---------------	--------------	--------------------	--------------------------

**Peak-to-Average Ratio on Channel 4132 (826.4 MHz)**

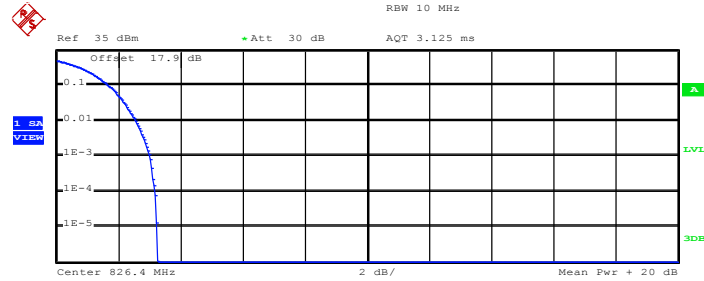

Complementary Cumulative Distribution Function (100000 samples)

Trace 1

Mean	22.84 dBm
Peak	26.08 dBm
Crest	3.24 dB
10 %	1.72 dB
1 %	2.56 dB
.1 %	3.00 dB
.01 %	3.20 dB

Date: 29.APR.2014 19:58:07

**Peak-to-Average Ratio on Channel 4182 (836.4 MHz)**

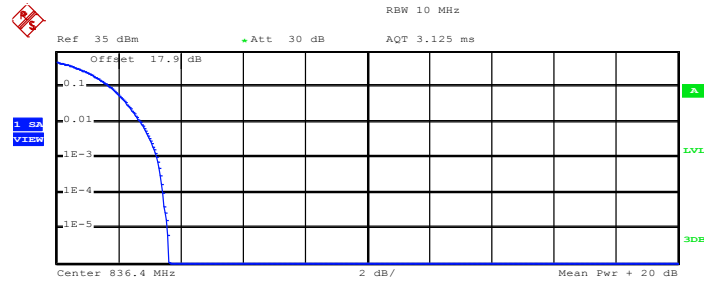

Complementary Cumulative Distribution Function (100000 samples)

Trace 1

Mean	22.18 dBm
Peak	25.80 dBm
Crest	3.62 dB
10 %	1.76 dB
1 %	2.72 dB
.1 %	3.24 dB
.01 %	3.44 dB

Date: 29.APR.2014 19:58:43



Peak-to-Average Ratio on Channel 4233 (846.6 MHz)

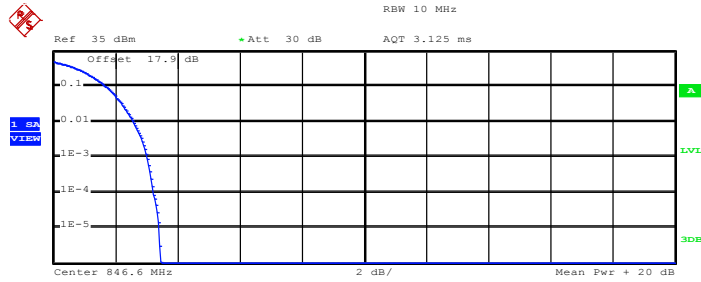

Complementary Cumulative Distribution Function (100000 samples)

Trace 1	
Mean	22.14 dBm
Peak	25.59 dBm
Crest	3.44 dB
10 %	1.72 dB
1 %	2.60 dB
.1 %	3.04 dB
.01 %	3.24 dB

Date: 29.APR.2014 19:59:23



### **3.3 Effective Radiated Power and Effective Isotropic Radiated Power Measurement**

#### **3.3.1 Description of the ERP/EIRP Measurement**

The substitution method, in ANSI / TIA / EIA-603-C-2004, was used for ERP/EIRP measurement, and the spectrum analyzer configuration follows KDB 971168 D01 Power Meas. License Digital Systems v02r01. The ERP of mobile transmitters must not exceed 7 Watts and the EIRP of mobile transmitters are limited to 2 Watts.

#### **3.3.2 Measuring Instruments**

The measuring equipment is listed in the section 4 of this test report.

#### **3.3.3 Test Procedures**

1. The EUT was placed on a non-conductive rotating platform 0.8 meters high in a semi-anechoic chamber. The radiated emission at the fundamental frequency was measured at 3 m with a test antenna and a spectrum analyzer with RMS detector per section 5. of KDB 971168 D01.
2. During the measurement, the system simulator parameters were set to force the EUT transmitting at maximum output power. The maximum emission was recorded from analyzer power level (LVL) from the 360 degrees rotation of the turntable and the test antenna raised and lowered over a range from 1 to 4 meters in both horizontally and vertically polarized orientations.
3. Effective Isotropic Radiated Power (EIRP) was measured by substitution method according to TIA/EIA-603-C. The EUT was replaced by dipole antenna (substitution antenna) at the same location, and then a known power from S.G. was applied into the dipole antenna through a Tx cable, and then recorded the maximum Analyzer reading through raised and lowered the test antenna. The correction factor (in dB) = S.G. - Tx Cable loss + Substitution antenna gain - Analyzer reading. Then the EUT's EIRP was calculated with the correction factor,  $EIRP = LVL + \text{Correction factor}$  and  $ERP = EIRP - 2.15$ .

### 3.3.4 Test Setup

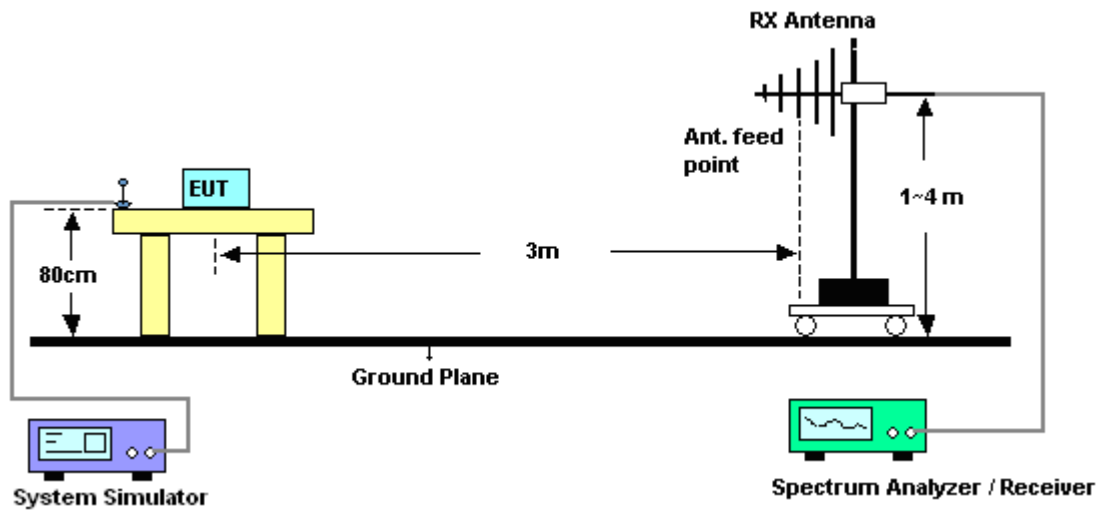

3.3.5 Test Result of ERP

GSM850 (GSM) Radiated Power ERP				
Horizontal Polarization				
Frequency (MHz)	LVL (dBm)	Correction Factor (dB)	ERP (dBm)	ERP (W)
824.20	-4.67	31.54	24.72	0.30
836.40	-4.97	32.04	24.92	0.31
848.80	-5.29	32.59	25.15	0.33
Vertical Polarization				
Frequency (MHz)	LVL (dBm)	Correction Factor (dB)	ERP (dBm)	ERP (W)
824.20	-8.84	32.93	21.94	0.16
836.40	-8.08	32.82	22.59	0.18
848.80	-8.78	33.62	22.69	0.19

\* ERP = LVL (dBm) + Correction Factor (dB) – 2.15

WCDMA Band V (RMC 12.2Kbps) Radiated Power ERP				
Horizontal Polarization				
Frequency (MHz)	LVL (dBm)	Correction Factor (dB)	ERP (dBm)	ERP (W)
826.40	-15.99	31.44	13.30	0.02
836.40	-14.96	32.04	14.93	0.03
846.60	-15.62	32.63	14.86	0.03
Vertical Polarization				
Frequency (MHz)	LVL (dBm)	Correction Factor (dB)	ERP (dBm)	ERP (W)
826.40	-22.96	32.78	7.67	0.01
836.40	-21.39	32.82	9.28	0.01
846.60	-21.47	33.40	9.78	0.01

\* ERP = LVL (dBm) + Correction Factor (dB) – 2.15



3.3.6 Test Result of EIRP

GSM1900 (GSM) Radiated Power EIRP				
Horizontal Polarization				
Frequency (MHz)	LVL (dBm)	Correction Factor (dB)	EIRP (dBm)	EIRP (W)
1850.2	-15.90	45.34	29.44	0.88
1880.0	-15.78	46.01	30.23	1.05
1909.8	-16.08	45.81	29.73	0.94
Vertical Polarization				
Frequency (MHz)	LVL (dBm)	Correction Factor (dB)	EIRP (dBm)	EIRP (W)
1850.2	-23.46	49.22	25.76	0.38
1880.0	-23.18	50.42	27.24	0.53
1909.8	-21.59	49.00	27.41	0.55

\* EIRP = LVL (dBm) + Correction Factor (dB)

### 3.4 99% Occupied Bandwidth and 26dB Bandwidth Measurement

#### 3.4.1 Description of 99% Occupied Bandwidth and 26dB Bandwidth Measurement

The 99% occupied bandwidth is the width of a frequency band such that, below the lower and above the upper frequency limits, the mean powers emitted are each equal to a specified percentage 0.5% of the total mean transmitted power.

The emission bandwidth is defined as the width of the signal between two points, located at the 2 sides of the carrier frequency, outside of which all emissions are attenuated at least 26 dB below the transmitter power.

#### 3.4.2 Measuring Instruments

The measuring equipment is listed in the section 4 of this test report.

#### 3.4.3 Test Procedures

1. The EUT was connected to the spectrum analyzer and system simulator via a power divider.
2. The RF output of the EUT was connected to the spectrum analyzer by RF cable and attenuator. The path loss was compensated to the results for each measurement.
3. The 99% occupied bandwidth were measured, set RBW= 1% of span, VBW= 3\*RBW, sample detector, trace maximum hold.
4. The 26dB bandwidth were measured, set RBW= 1% of EBW, VBW= 3\*RBW, peak detector, trace maximum hold.

#### 3.4.4 Test Setup

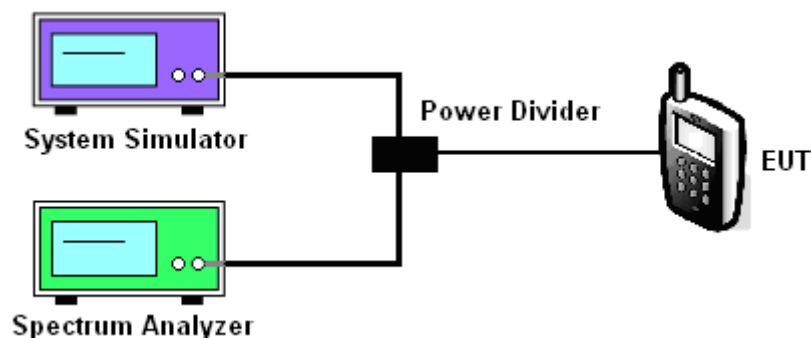



3.4.5 Test Result of Occupied Bandwidth and 26dB Bandwidth

Cellular Band			
Modes	GSM850 (GSM)		
Channel	128 (Low)	189 (Mid)	251 (High)
Frequency (MHz)	824.2	836.4	848.8
99% OBW (kHz)	250.00	250.00	248.00
26dB BW (kHz)	314.00	316.00	316.00

PCS Band			
Modes	GSM1900 (GSM)		
Channel	512 (Low)	661 (Mid)	810 (High)
Frequency (MHz)	1850.2	1880	1909.8
99% OBW (kHz)	246.00	248.00	250.00
26dB BW (kHz)	308.00	314.00	316.00

Cellular Band			
Modes	WCDMA Band V (RMC 12.2Kbps)		
Channel	4132 (Low)	4182 (Mid)	4233 (High)
Frequency (MHz)	826.4	836.4	846.6
99% OBW (MHz)	4.08	4.12	4.10
26dB BW (MHz)	4.68	4.68	4.68



3.4.6 Test Result (Plots) of Occupied Bandwidth and 26dB Bandwidth

Band :	GSM 850	Test Mode :	GSM Link (GMSK)
--------	---------	-------------	-----------------

99% Occupied Bandwidth Plot on Channel 128 (824.2 MHz)

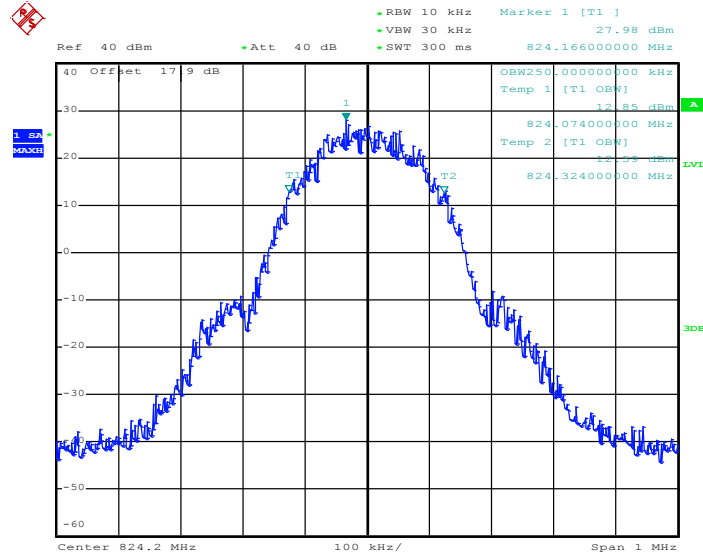

Date: 29.APR.2014 13:39:42

26dB Bandwidth Plot on Channel 128 (824.2 MHz)

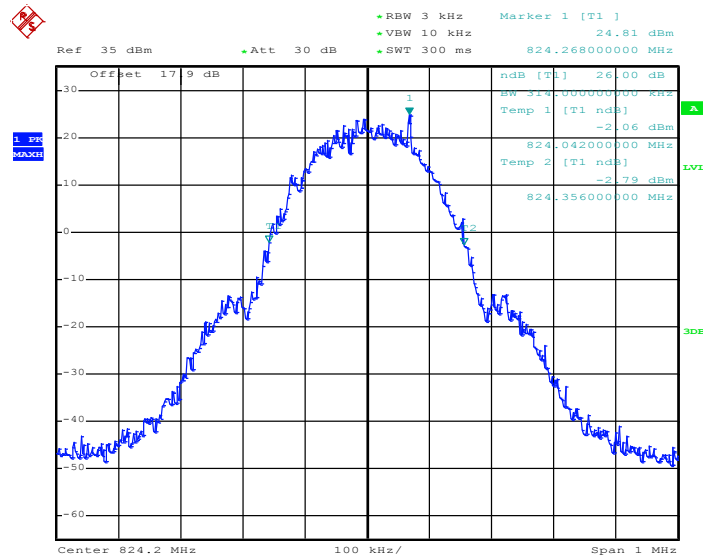

Date: 29.APR.2014 11:56:48



99% Occupied Bandwidth Plot on Channel 189 (836.4 MHz)

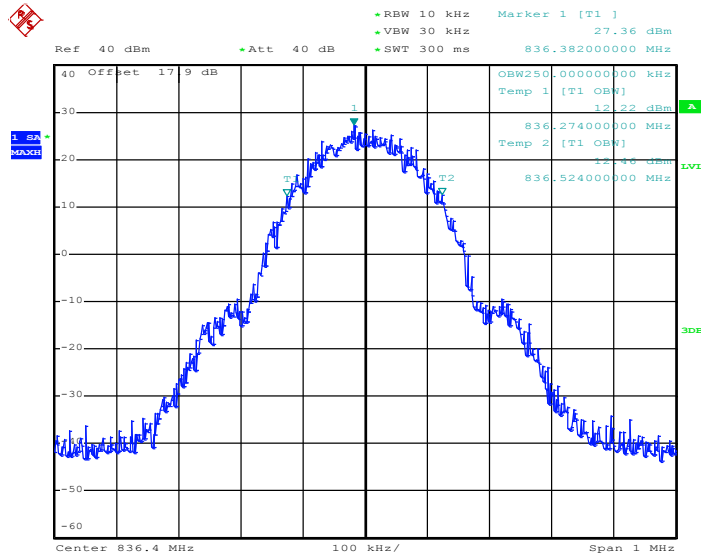

Date: 29.APR.2014 11:59:09

26dB Bandwidth Plot on Channel 189 (836.4 MHz)

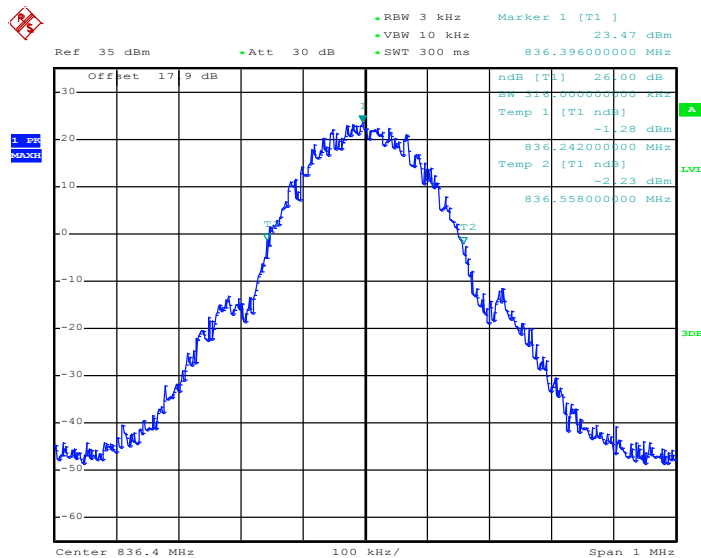

Date: 29.APR.2014 11:57:16



99% Occupied Bandwidth Plot on Channel 251 (848.8 MHz)

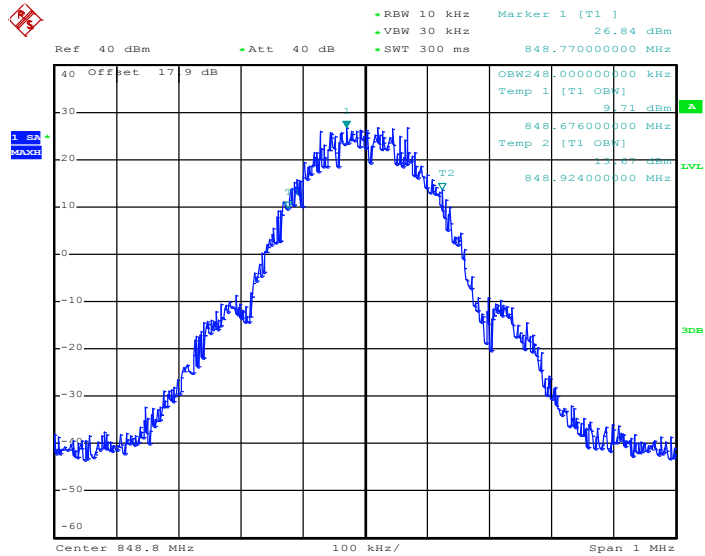

Date: 29.APR.2014 11:59:38

26dB Bandwidth Plot on Channel 251 (848.8 MHz)

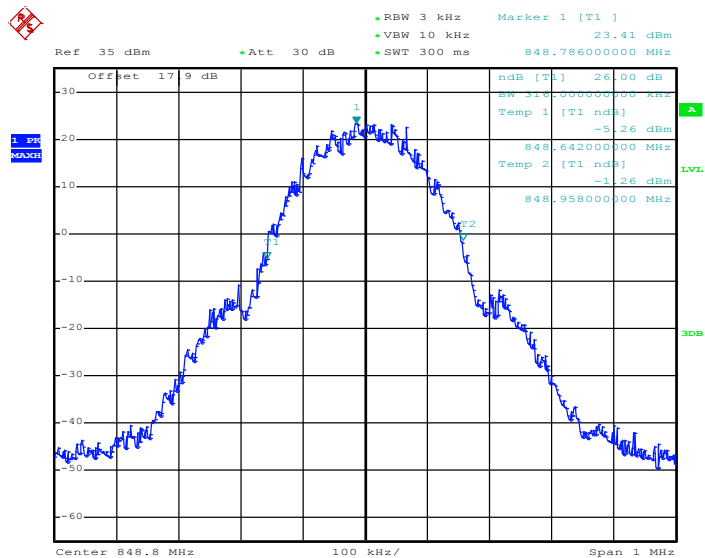

Date: 29.APR.2014 11:57:45



<b>Band :</b>	GSM 1900	<b>Test Mode :</b>	GSM Link (GMSK)
---------------	----------	--------------------	-----------------

99% Occupied Bandwidth Plot on Channel 512 (1850.2 MHz)

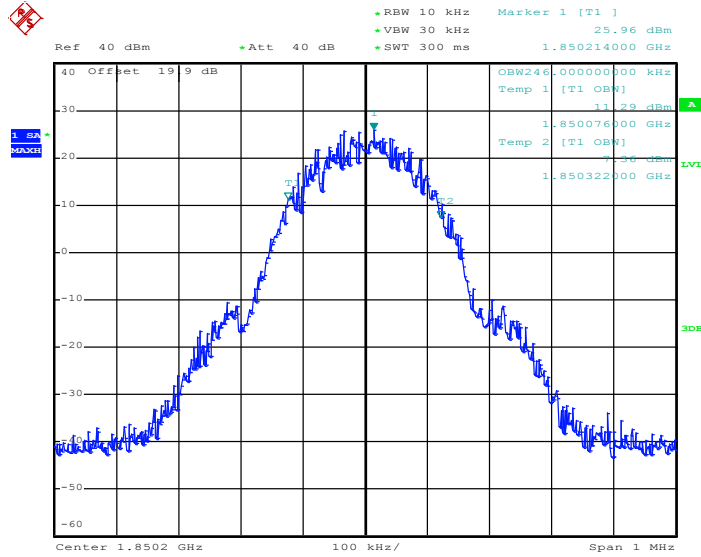

Date: 29.APR.2014 14:20:35

26dB Bandwidth Plot on Channel 512 (1850.2 MHz)

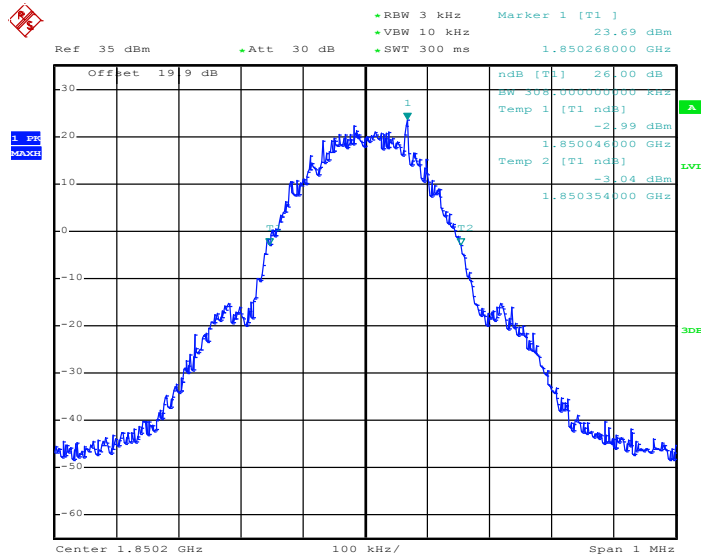

Date: 29.APR.2014 14:18:41



99% Occupied Bandwidth Plot on Channel 661 (1880.0 MHz)

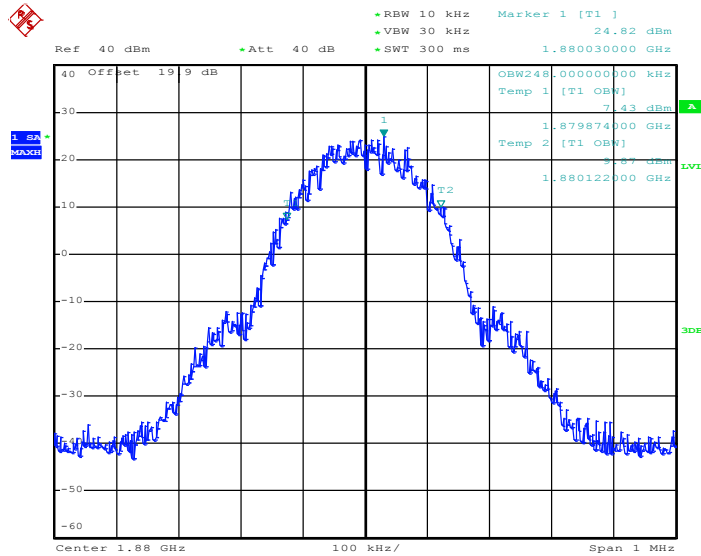

Date: 29.APR.2014 14:21:04

26dB Bandwidth Plot on Channel 661 (1880.0 MHz)

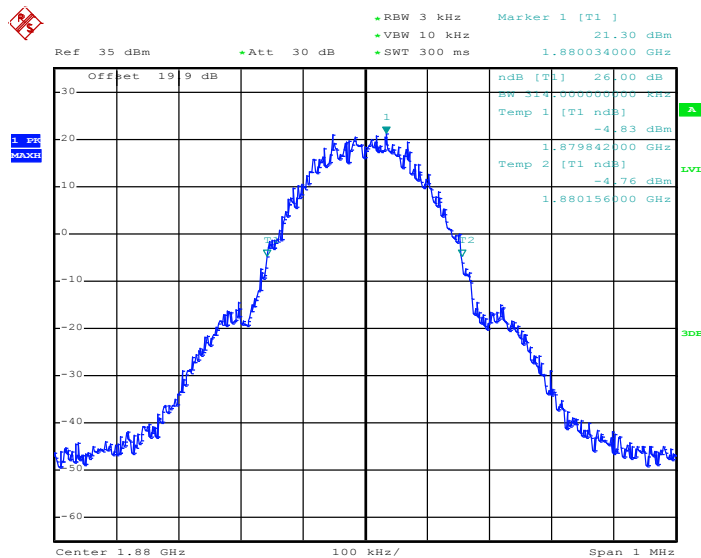

Date: 29.APR.2014 14:19:10



99% Occupied Bandwidth Plot on Channel 810 (1909.8 MHz)

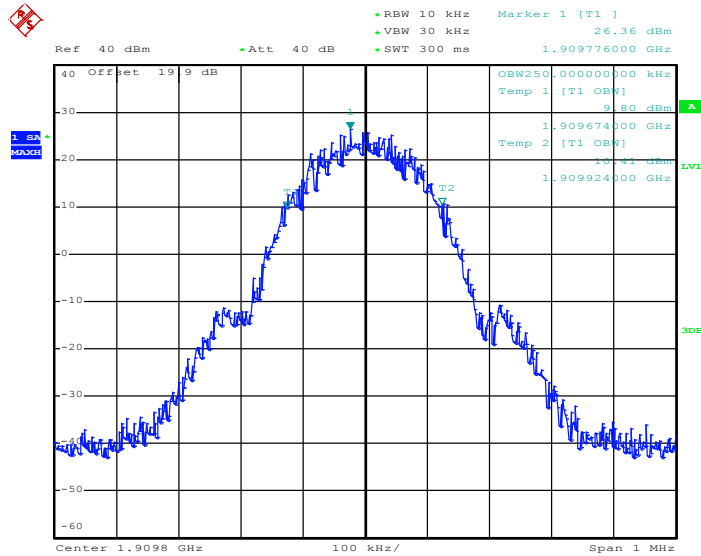

Date: 29.APR.2014 14:21:32

26dB Bandwidth Plot on Channel 810 (1909.8 MHz)

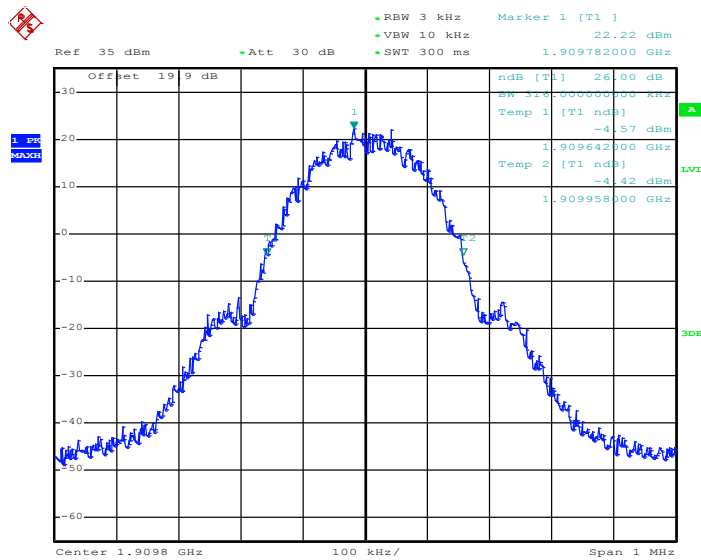

Date: 29.APR.2014 14:19:39



<b>Band :</b>	WCDMA Band V	<b>Test Mode :</b>	RMC 12.2Kbps Link (QPSK)
---------------	--------------	--------------------	--------------------------

99% Occupied Bandwidth Plot on Channel 4132 (826.4 MHz)

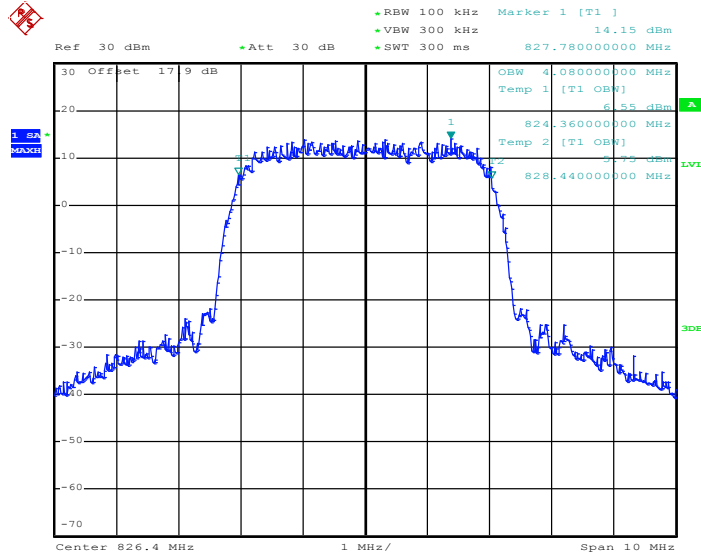

Date: 29.APR.2014 19:46:46

26dB Bandwidth Plot on Channel 4132 (826.4 MHz)

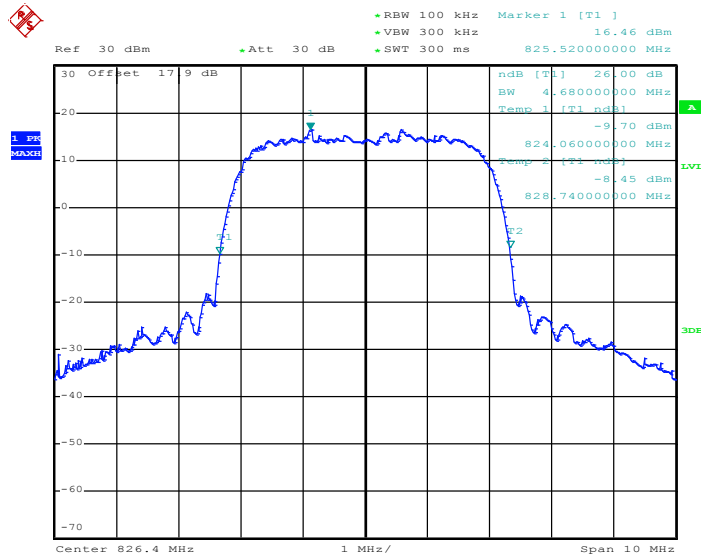

Date: 29.APR.2014 19:44:57



99% Occupied Bandwidth Plot on Channel 4182 (836.4 MHz)

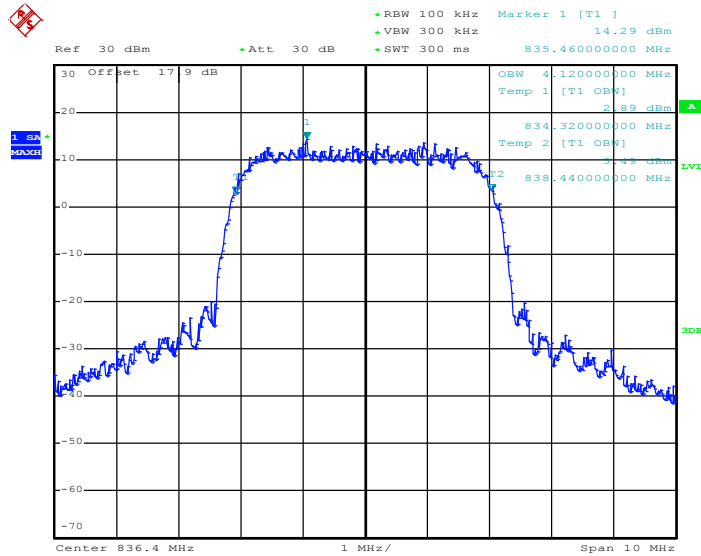

Date: 29.APR.2014 19:47:14

26dB Bandwidth Plot on Channel 4182 (836.4 MHz)

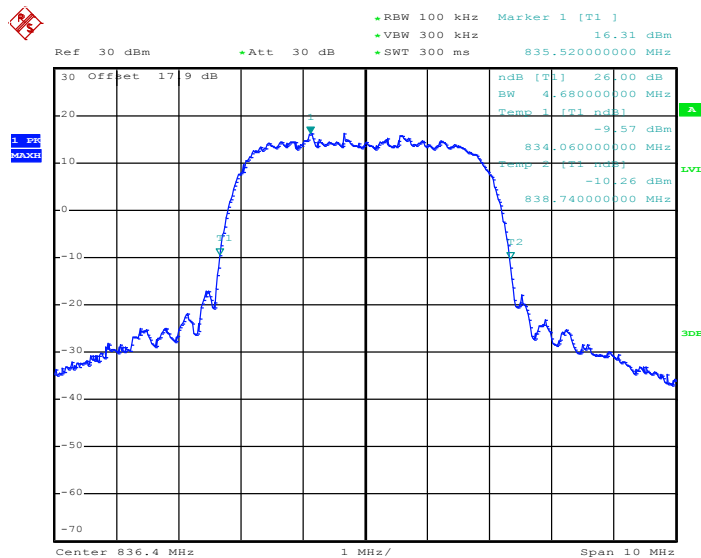

Date: 29.APR.2014 19:45:25



99% Occupied Bandwidth Plot on Channel 4233 (846.6 MHz)

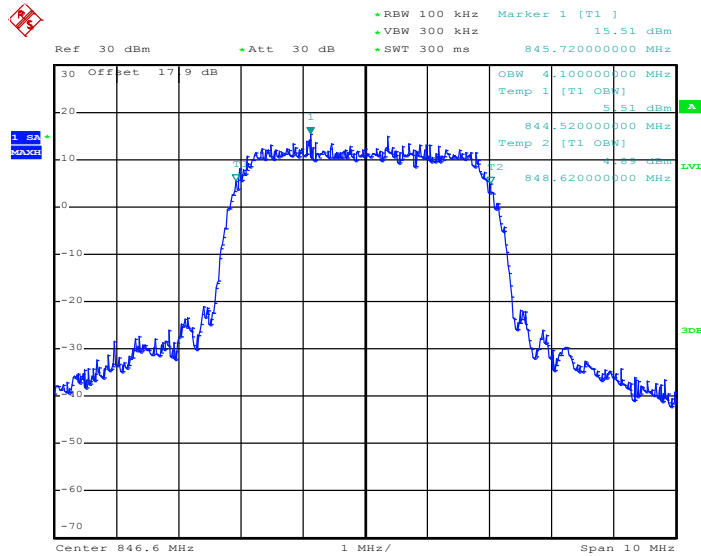

Date: 29.APR.2014 19:47:43

26dB Bandwidth Plot on Channel 4233 (846.6 MHz)

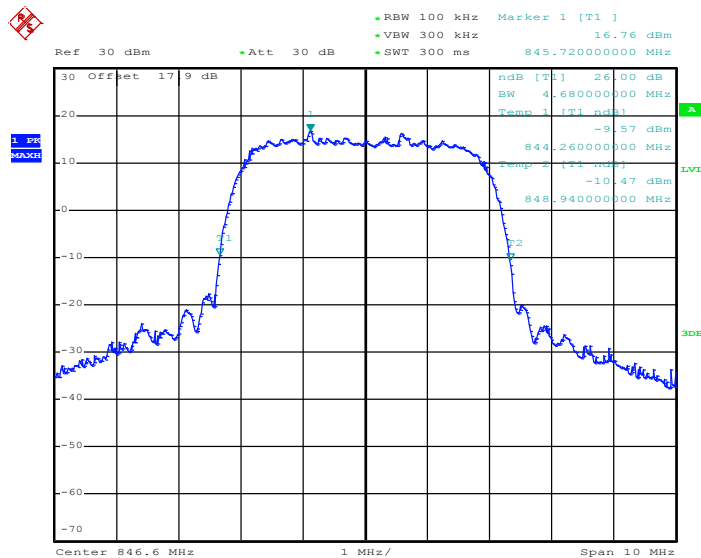

Date: 29.APR.2014 19:45:54

### 3.5 Band Edge Measurement

#### 3.5.1 Description of Band Edge Measurement

The power of any emission outside of the authorized operating frequency ranges must be lower than the transmitter power (P) by a factor of at least  $43 + 10 \log (P)$  dB.

#### 3.5.2 Measuring Instruments

The measuring equipment is listed in the section 4 of this test report.

#### 3.5.3 Test Procedures

1. The EUT was connected to the spectrum analyzer and system simulator via a power divider.
2. The RF output of EUT was connected to the spectrum analyzer by an RF cable and attenuator. The path loss was compensated to the results for each measurement.
3. The band edges of low and high channels for the highest RF powers were measured.
4. The RF fundamental frequency should be excluded against the limit line in the operating frequency band.
5. The limit line is derived from  $43 + 10\log(P)$  dB below the transmitter power P(Watts)
 
$$= P(W) - [43 + 10\log(P)] \text{ (dB)}$$

$$= [30 + 10\log(P)] \text{ (dBm)} - [43 + 10\log(P)] \text{ (dB)}$$

$$= -13\text{dBm}.$$

#### 3.5.4 Test Setup

<Conducted Band Edge >

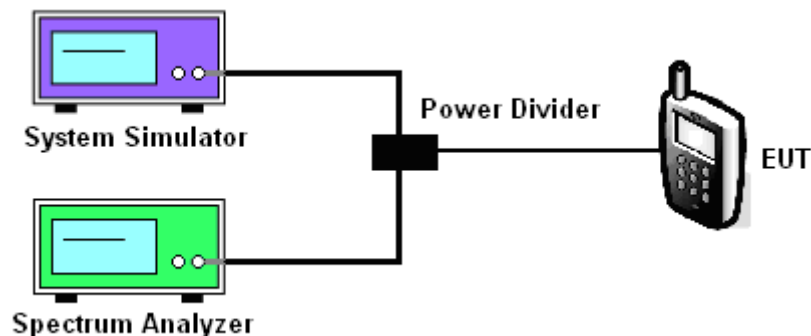



### 3.5.5 Test Result (Plots) of Conducted Band Edge

Band :	GSM850	Test Mode :	GSM Link (GMSK)
--------	--------	-------------	-----------------

Lower Band Edge Plot on Channel 128 (824.2 MHz)

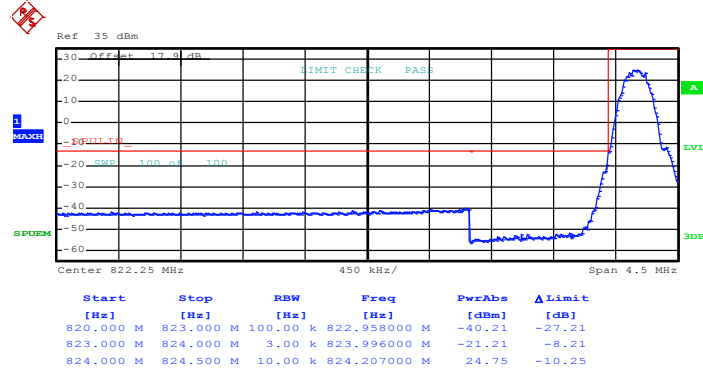

Date: 29.APR.2014 13:49:44

Higher Band Edge Plot on Channel 251 (848.8 MHz)

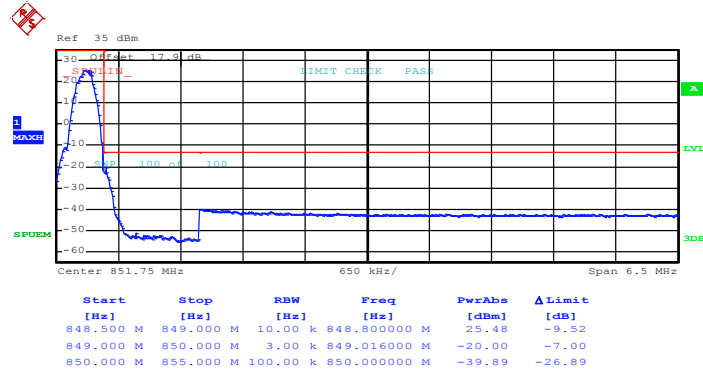

Date: 29.APR.2014 13:46:42



Band :	GSM1900	Test Mode :	GSM Link (GMSK)
--------	---------	-------------	-----------------

Lower Band Edge Plot on Channel 512 (1850.2 MHz)

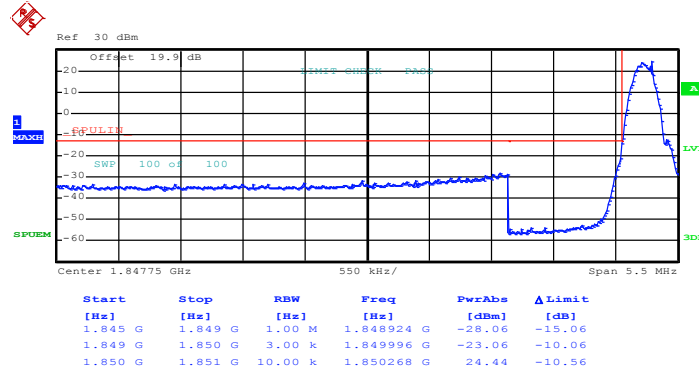

Date: 29.APR.2014 14:29:19

Higher Band Edge Plot on Channel 810 (1909.8 MHz)

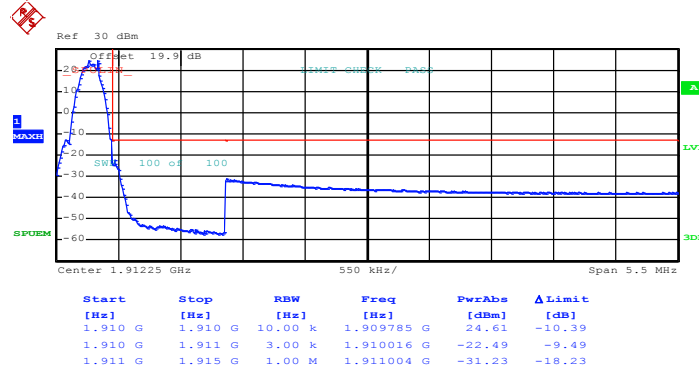

Date: 29.APR.2014 14:26:18



Band :	WCDMA Band V	Test Mode :	RMC 12.2Kbps Link (QPSK)
--------	--------------	-------------	--------------------------

Lower Band Edge Plot on Channel 4132 (826.4 MHz)

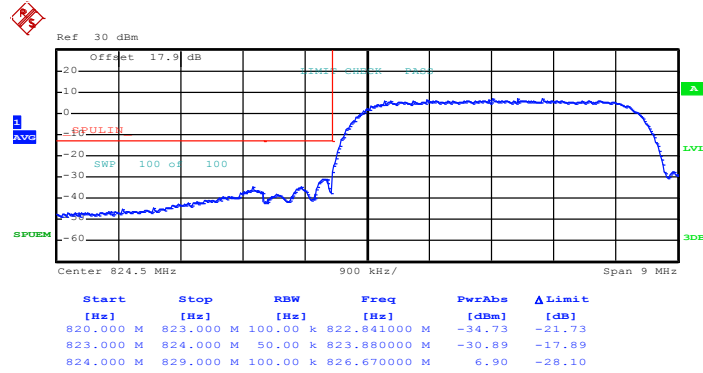

Date: 29.APR.2014 19:54:46

Higher Band Edge Plot on Channel 4233 (846.6 MHz)

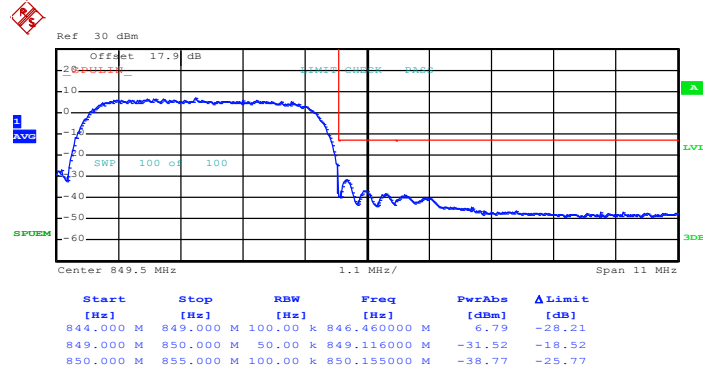

Date: 29.APR.2014 19:51:09

### 3.6 Conducted Spurious Emission Measurement

#### 3.6.1 Description of Conducted Spurious Emission Measurement

The power of any emission outside of the authorized operating frequency ranges must be lower than the transmitter power (P) by a factor of at least  $43 + 10 \log (P)$  dB.

It is measured by means of a calibrated spectrum analyzer and scanned from 30 MHz up to a frequency including its 10<sup>th</sup> harmonic.

#### 3.6.2 Measuring Instruments

The measuring equipment is listed in the section 4 of this test report.

#### 3.6.3 Test Procedures

1. The EUT was connected to the spectrum analyzer and system simulator via a power divider.
2. The RF output of EUT was connected to the spectrum analyzer by an RF cable and attenuator. The path loss was compensated to the results for each measurement.
3. The middle channel for the highest RF power within the transmitting frequency was measured.
4. The conducted spurious emission for the whole frequency range was taken.
5. The RF fundamental frequency should be excluded against the limit line in the operating frequency band.
6. The limit line is derived from  $43 + 10\log(P)$  dB below the transmitter power P(Watts)
 
$$= P(W) - [43 + 10\log(P)] \text{ (dB)}$$

$$= [30 + 10\log(P)] \text{ (dBm)} - [43 + 10\log(P)] \text{ (dB)}$$

$$= -13\text{dBm}.$$

#### 3.6.4 Test Setup

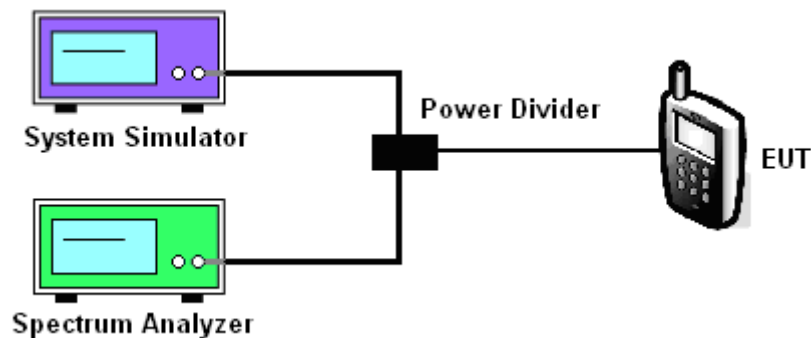



### 3.6.5 Test Result (Plots) of Conducted Spurious Emission

Band :	GSM850	Channel :	CH128
Test Mode :	GSM Link (GMSK)	Frequency :	824.2 MHz

Conducted Spurious Emission Plot between 30MHz ~ 1GHz

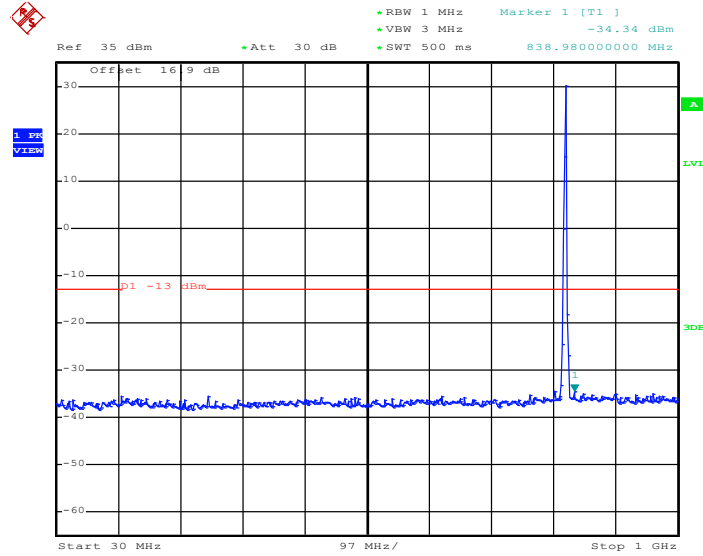

Date: 29.APR.2014 14:09:33

Conducted Spurious Emission Plot between 1GHz ~ 3GHz

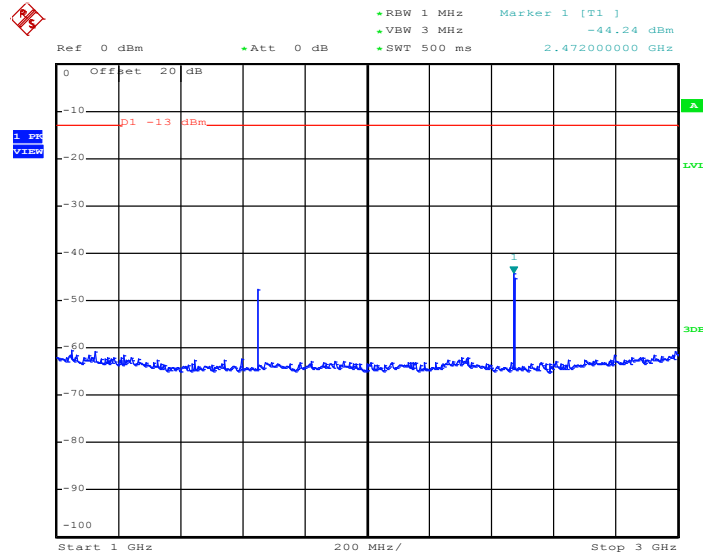

Date: 29.APR.2014 14:09:45



### Conducted Spurious Emission Plot between 3GHz ~ 7GHz

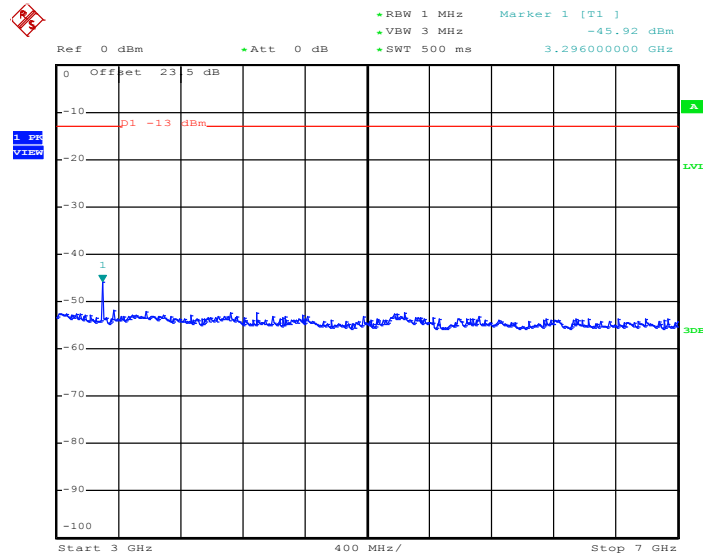

Date: 29.APR.2014 14:09:53

### Conducted Spurious Emission Plot between 7GHz ~ 9GHz

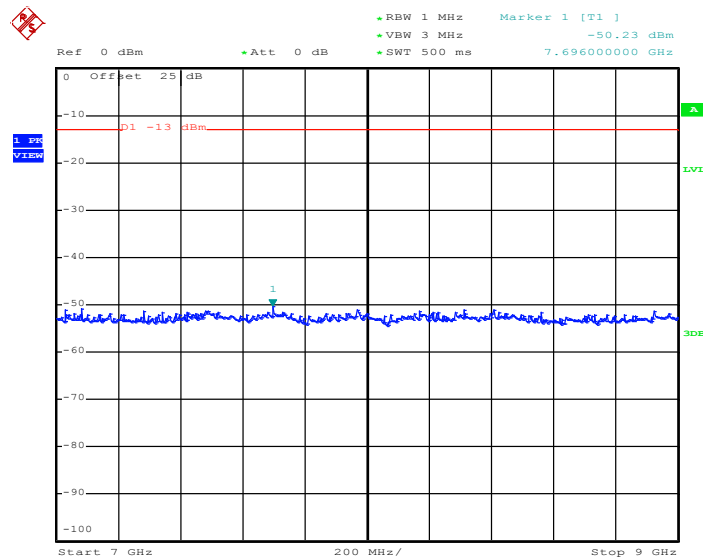

Date: 29.APR.2014 14:10:01



<b>Band :</b>	GSM850	<b>Channel :</b>	CH189
<b>Test Mode :</b>	GSM Link (GMSK)	<b>Frequency :</b>	836.4 MHz

Conducted Spurious Emission Plot between 30MHz ~ 1GHz

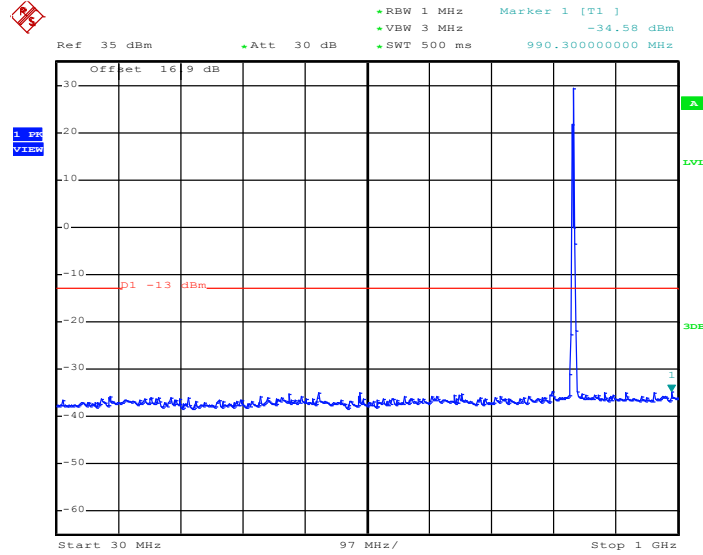

Date: 29.APR.2014 13:57:27

Conducted Spurious Emission Plot between 1GHz ~ 3GHz

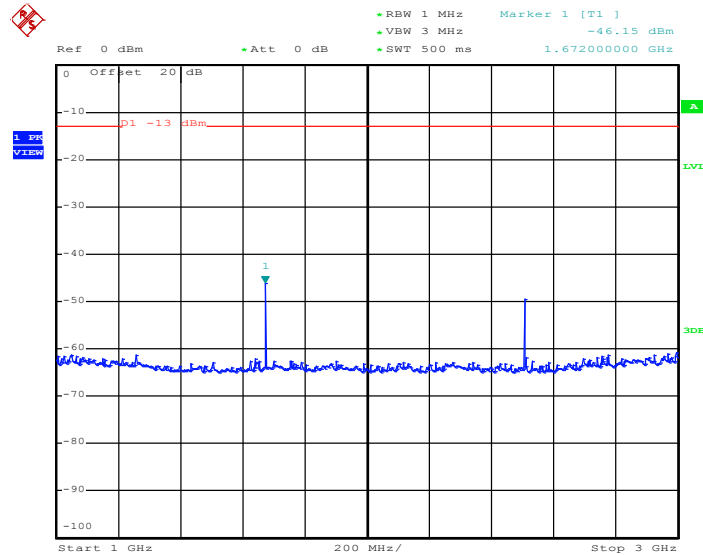

Date: 29.APR.2014 13:57:39



### Conducted Spurious Emission Plot between 3GHz ~ 7GHz

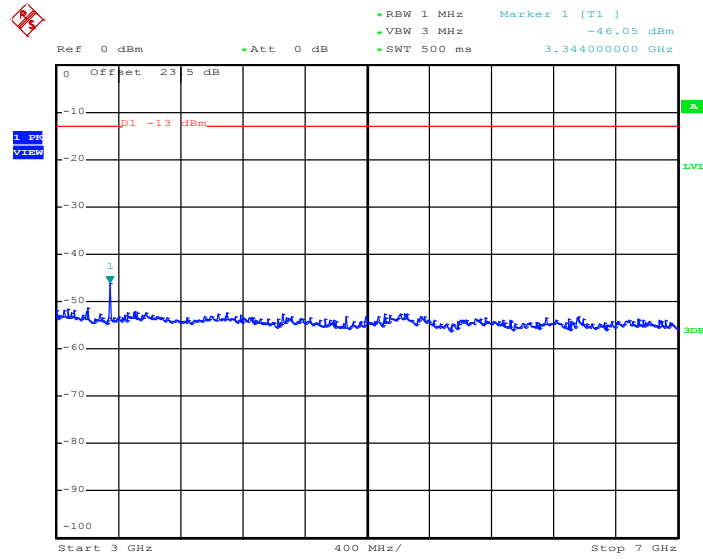

Date: 29.APR.2014 13:57:48

### Conducted Spurious Emission Plot between 7GHz ~ 9GHz

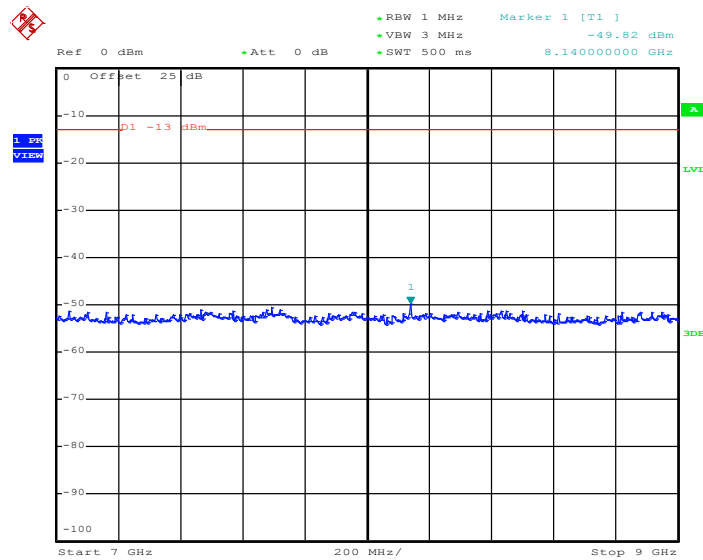

Date: 29.APR.2014 13:57:56



Band :	GSM850	Channel :	CH251
Test Mode :	GSM Link (GMSK)	Frequency :	848.8 MHz

Conducted Spurious Emission Plot between 30MHz ~ 1GHz

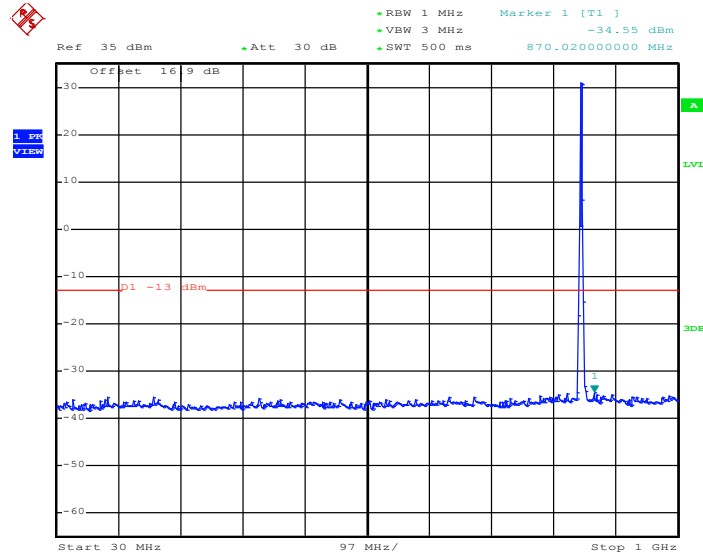

Date: 29.APR.2014 14:13:06

Conducted Spurious Emission Plot between 1GHz ~ 3GHz

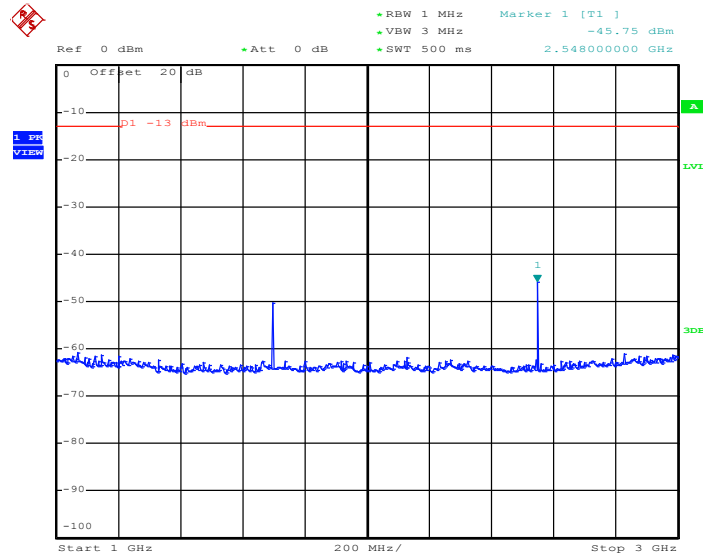

Date: 29.APR.2014 14:13:21



### Conducted Spurious Emission Plot between 3GHz ~ 7GHz

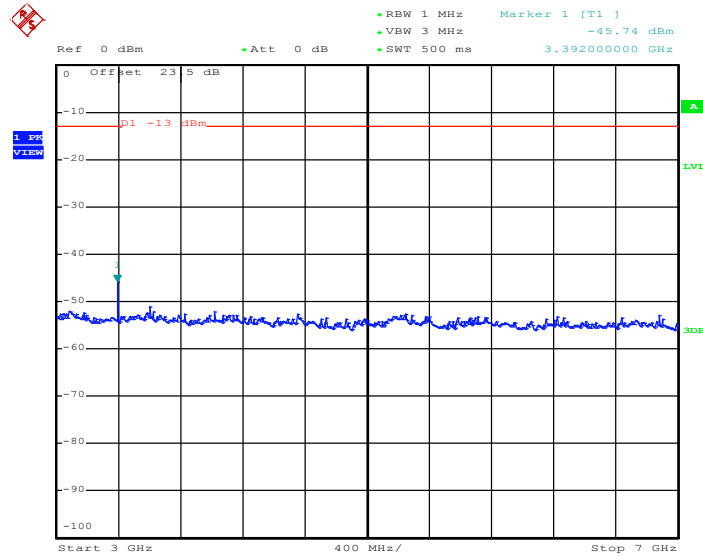

Date: 29.APR.2014 14:13:29

### Conducted Spurious Emission Plot between 7GHz ~ 9GHz

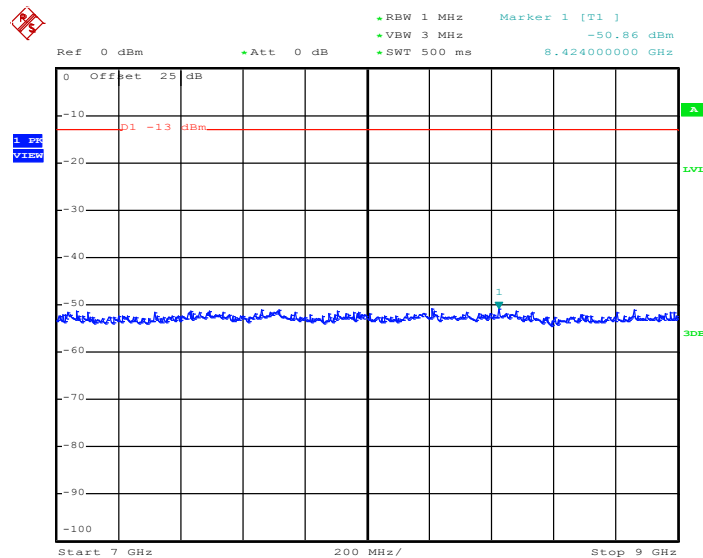

Date: 29.APR.2014 14:13:37



Band :	GSM1900	Channel :	CH512
Test Mode :	GSM Link (GMSK)	Frequency :	1850.2 MHz

Conducted Spurious Emission Plot between 30MHz ~ 1GHz

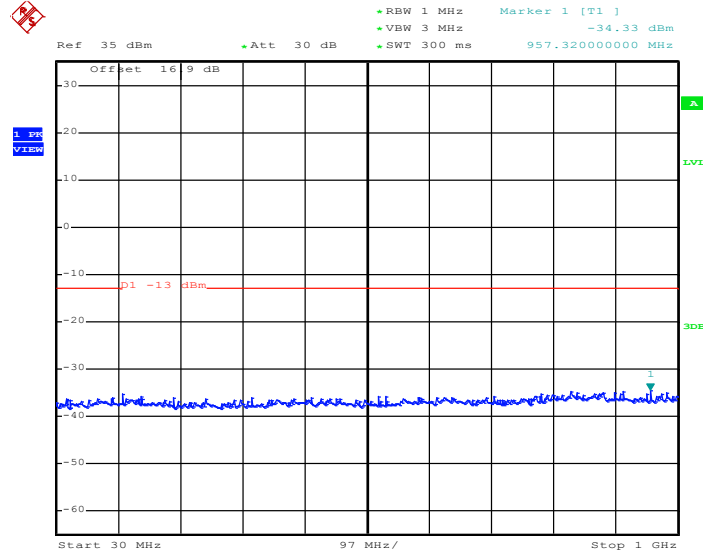

Date: 29.APR.2014 18:55:48

Conducted Spurious Emission Plot between 1GHz ~ 3GHz

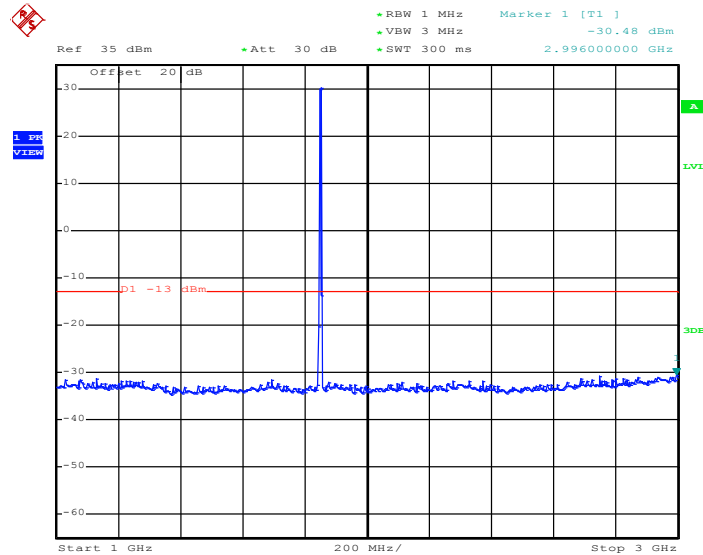

Date: 29.APR.2014 18:55:57



### Conducted Spurious Emission Plot between 3GHz ~ 7GHz

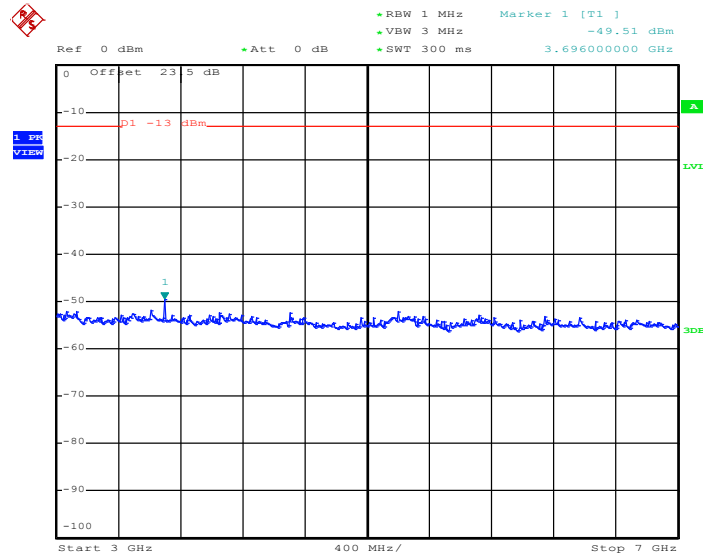

Date: 29.APR.2014 18:56:08

### Conducted Spurious Emission Plot between 7GHz ~ 13.6GHz

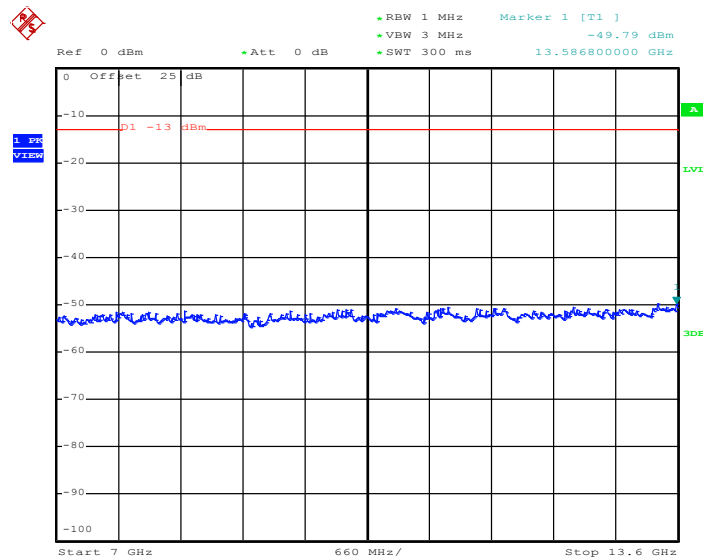

Date: 29.APR.2014 18:56:16



Conducted Spurious Emission Plot between 13.6GHz ~ 19.1GHz

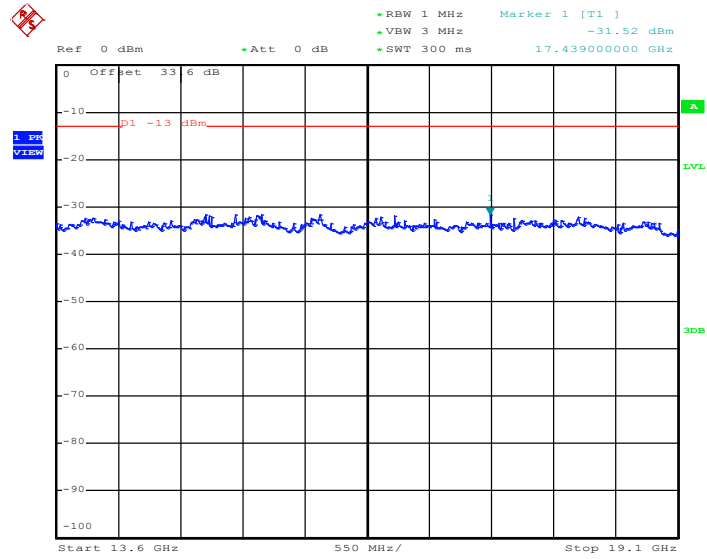

Date: 29.APR.2014 18:56:25



<b>Band :</b>	GSM1900	<b>Channel :</b>	CH661
<b>Test Mode :</b>	GSM Link (GMSK)	<b>Frequency :</b>	1880.0 MHz

Conducted Spurious Emission Plot between 30MHz ~ 1GHz

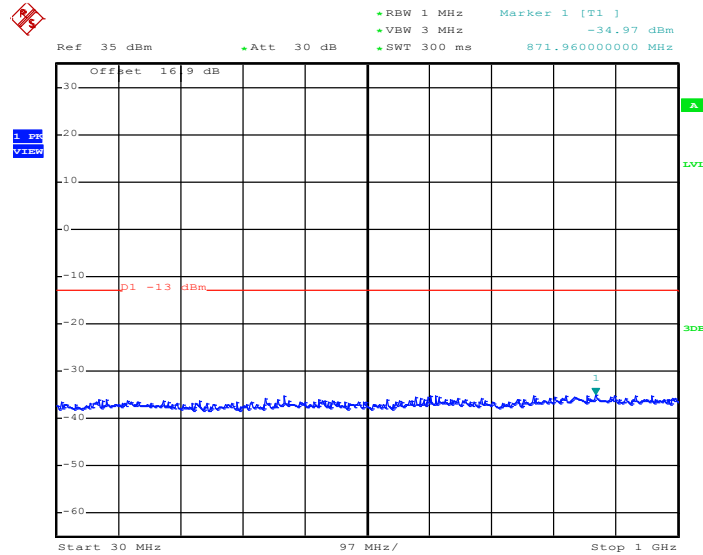

Date: 29.APR.2014 18:52:53

Conducted Spurious Emission Plot between 1GHz ~ 3GHz

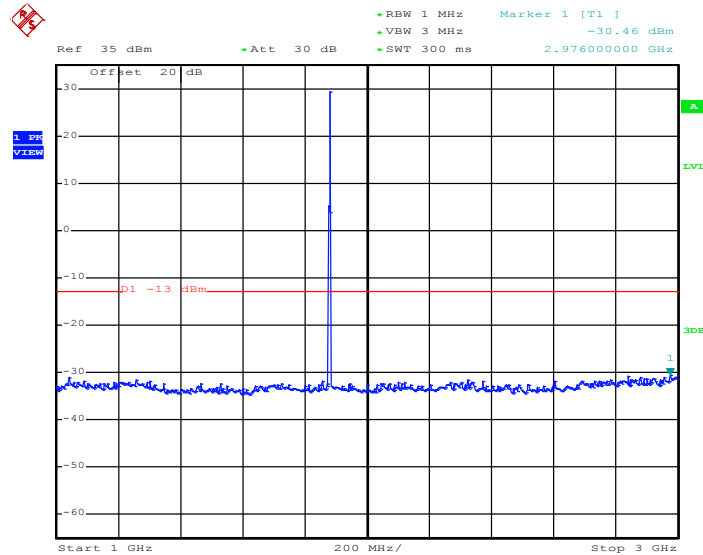

Date: 29.APR.2014 18:53:02



### Conducted Spurious Emission Plot between 3GHz ~ 7GHz

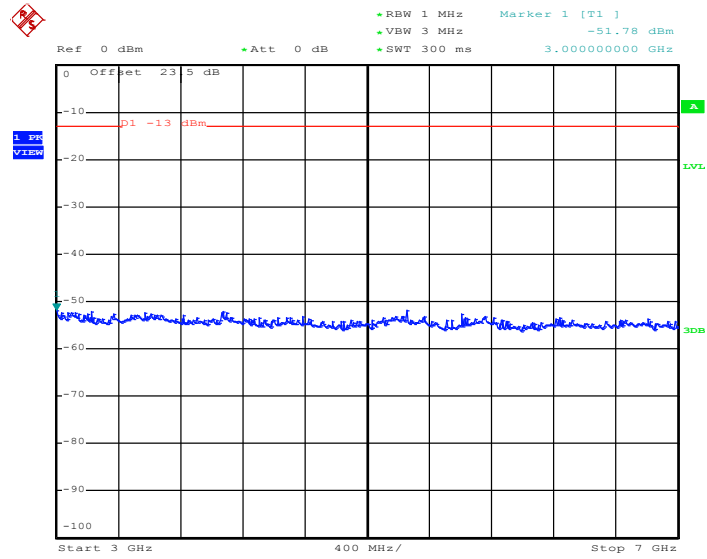

Date: 29.APR.2014 18:53:13

### Conducted Spurious Emission Plot between 7GHz ~ 13.6GHz

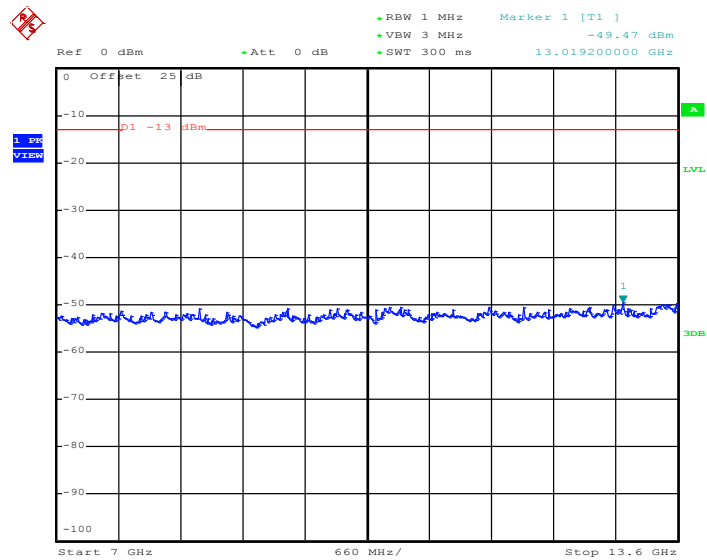

Date: 29.APR.2014 18:53:21



Conducted Spurious Emission Plot between 13.6GHz ~ 19.1GHz

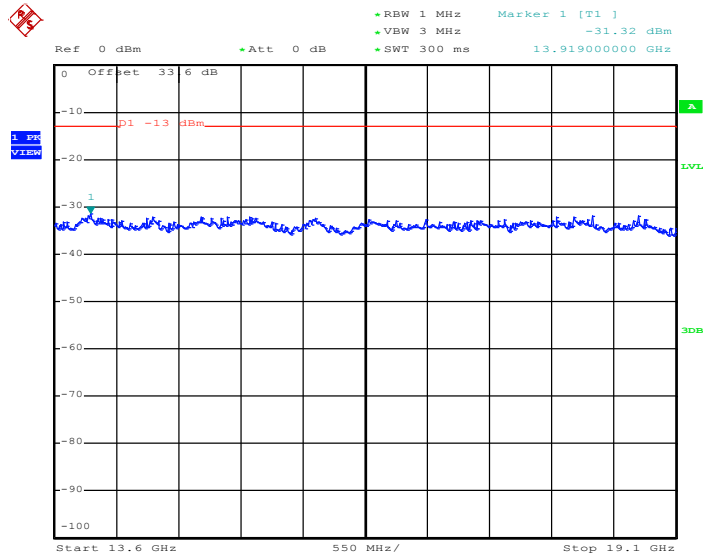

Date: 29.APR.2014 18:53:30



Band :	GSM1900	Channel :	CH810
Test Mode :	GSM Link (GMSK)	Frequency :	1909.8 MHz

Conducted Spurious Emission Plot between 30MHz ~ 1GHz

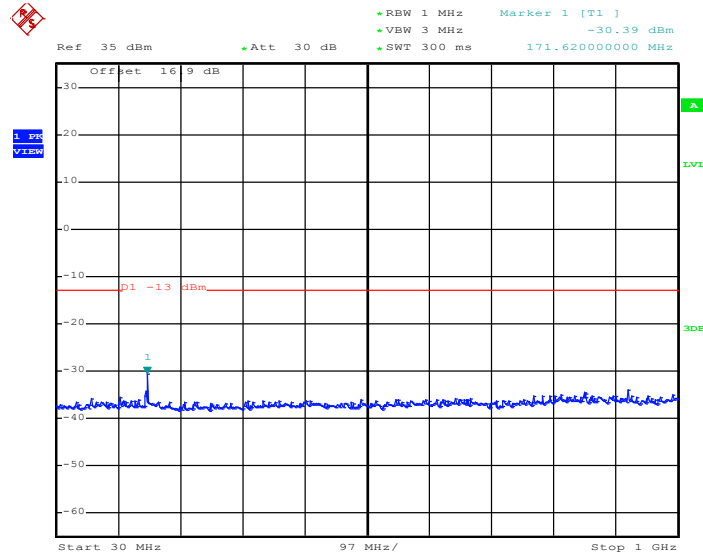

Date: 29.APR.2014 18:57:27

Conducted Spurious Emission Plot between 1GHz ~ 3GHz

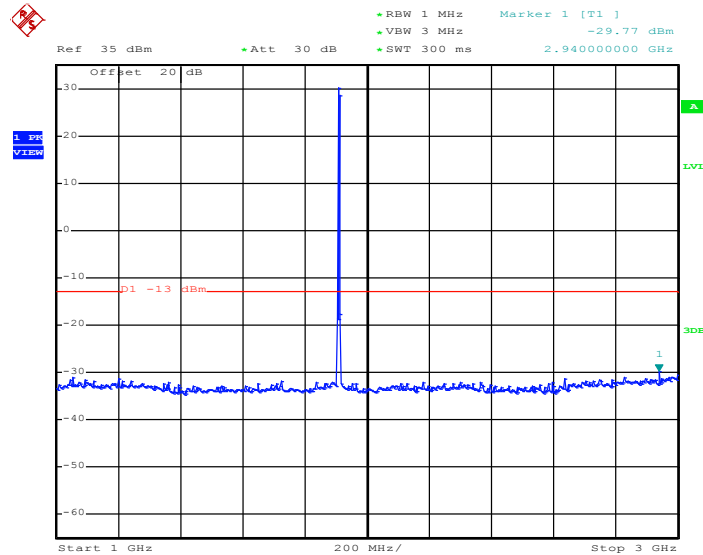

Date: 29.APR.2014 18:57:35



### Conducted Spurious Emission Plot between 3GHz ~ 7GHz

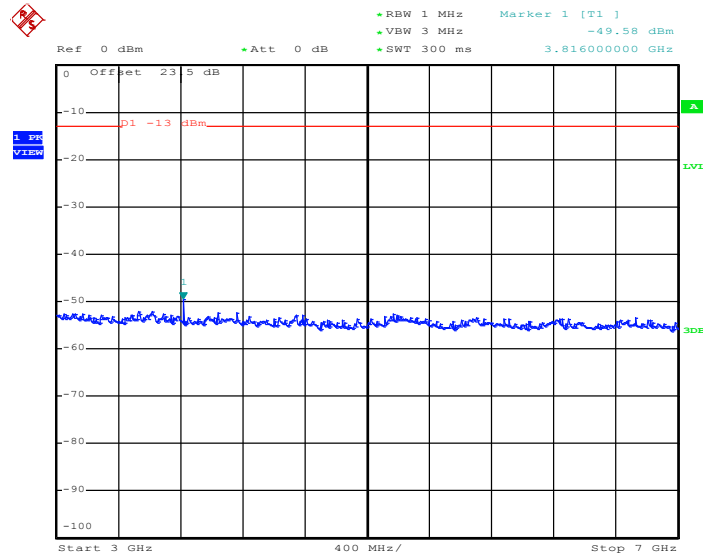

Date: 29.APR.2014 18:57:48

### Conducted Spurious Emission Plot between 7GHz ~ 13.6GHz

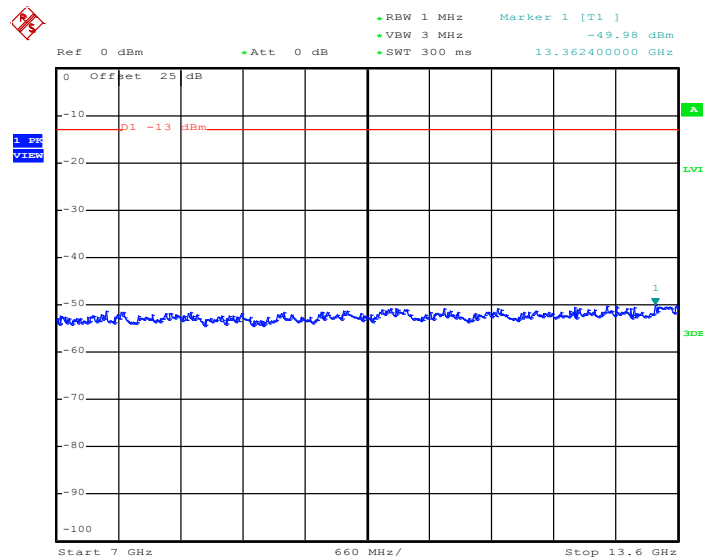

Date: 29.APR.2014 18:57:56



Conducted Spurious Emission Plot between 13.6GHz ~ 19.1GHz

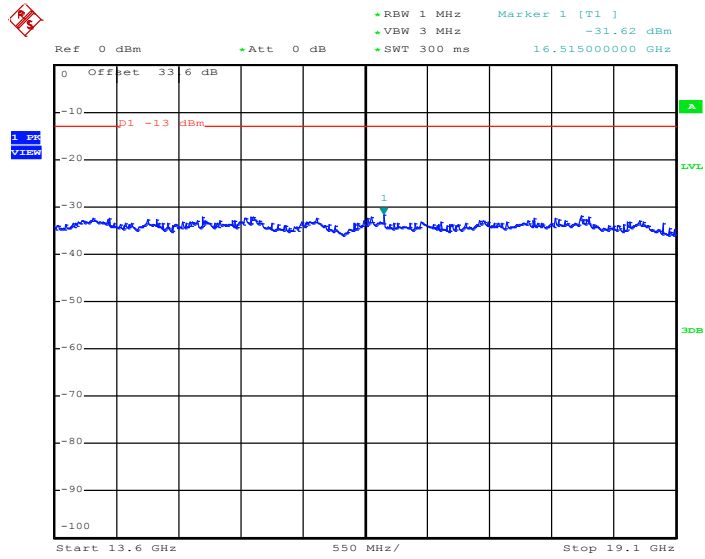

Date: 29.APR.2014 18:58:04



Band :	WCDMA Band V	Channel :	CH4132
Test Mode :	RMC 12.2Kbps Link (QPSK)	Frequency :	826.4 MHz

Conducted Spurious Emission Plot between 30MHz ~ 1GHz

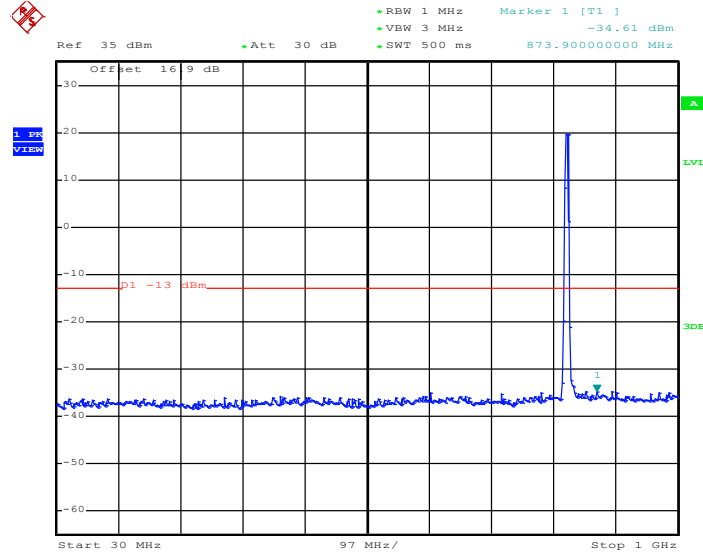

Date: 29.APR.2014 20:02:59

Conducted Spurious Emission Plot between 1GHz ~ 3GHz

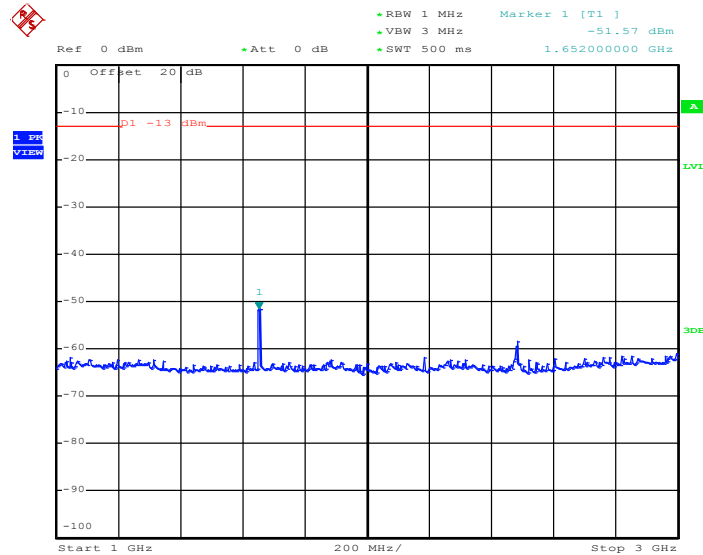

Date: 29.APR.2014 20:03:14



### Conducted Spurious Emission Plot between 3GHz ~ 7GHz

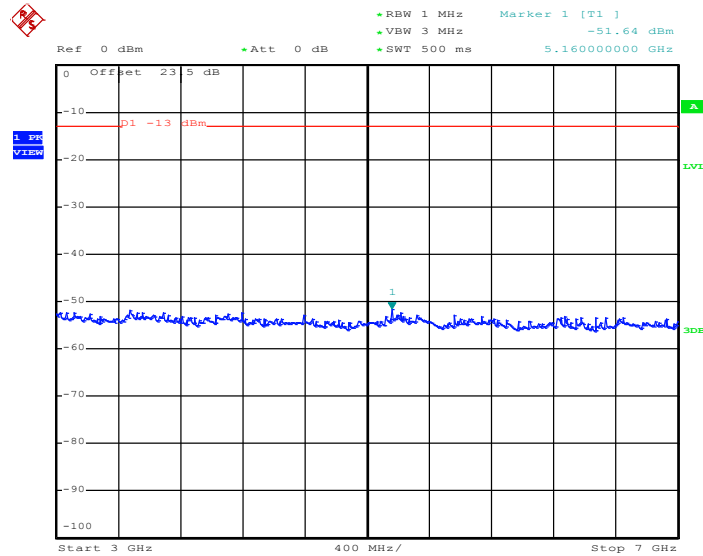

Date: 29.APR.2014 20:03:22

### Conducted Spurious Emission Plot between 7GHz ~ 9GHz

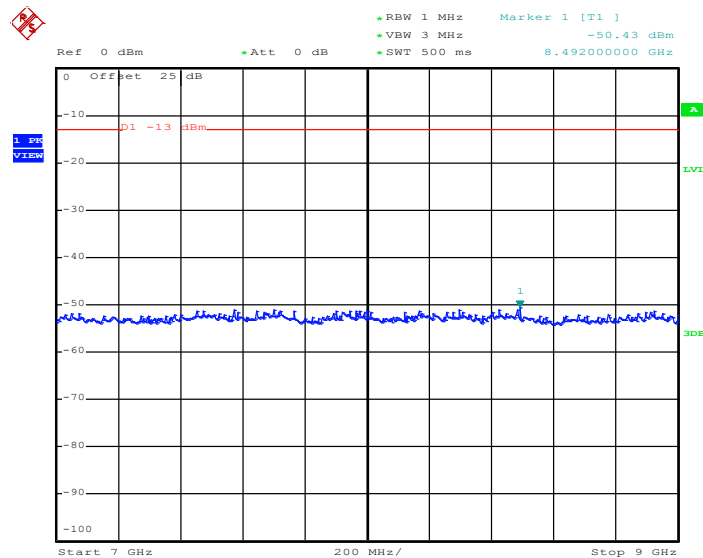

Date: 29.APR.2014 20:03:31



<b>Band :</b>	WCDMA Band V	<b>Channel :</b>	CH4182
<b>Test Mode :</b>	RMC 12.2Kbps Link (QPSK)	<b>Frequency :</b>	836.4 MHz

Conducted Spurious Emission Plot between 30MHz ~ 1GHz

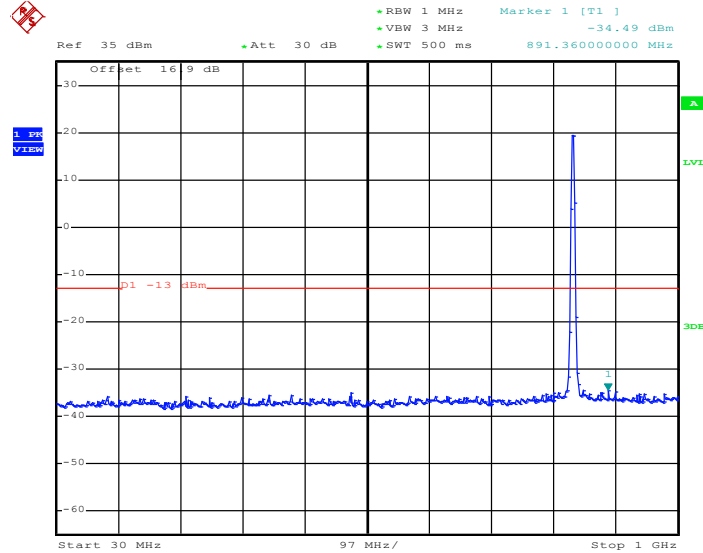

Date: 29.APR.2014 20:00:46

Conducted Spurious Emission Plot between 1GHz ~ 3GHz

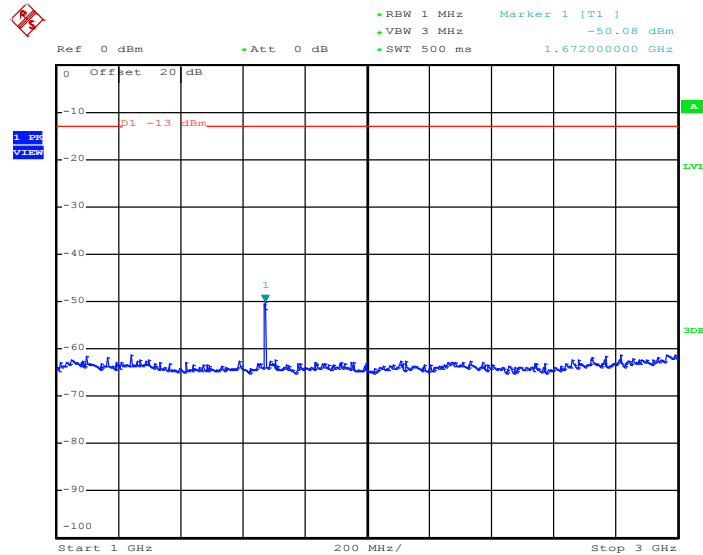

Date: 29.APR.2014 20:00:56



### Conducted Spurious Emission Plot between 3GHz ~ 7GHz

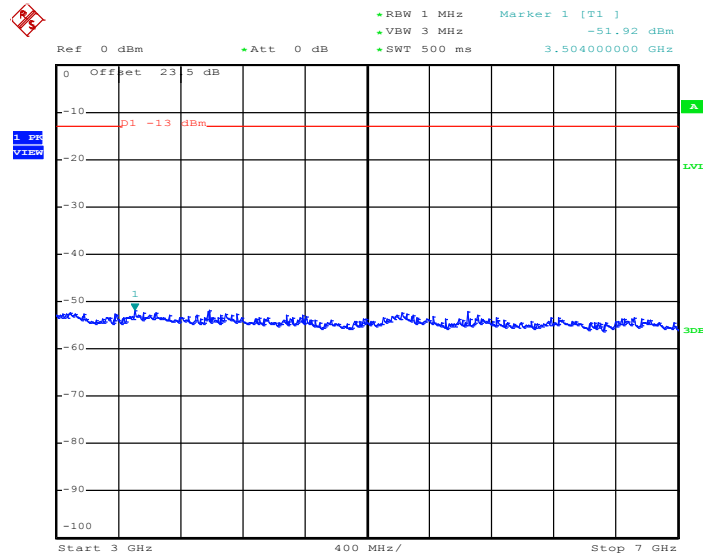

Date: 29.APR.2014 20:01:04

### Conducted Spurious Emission Plot between 7GHz ~ 9GHz

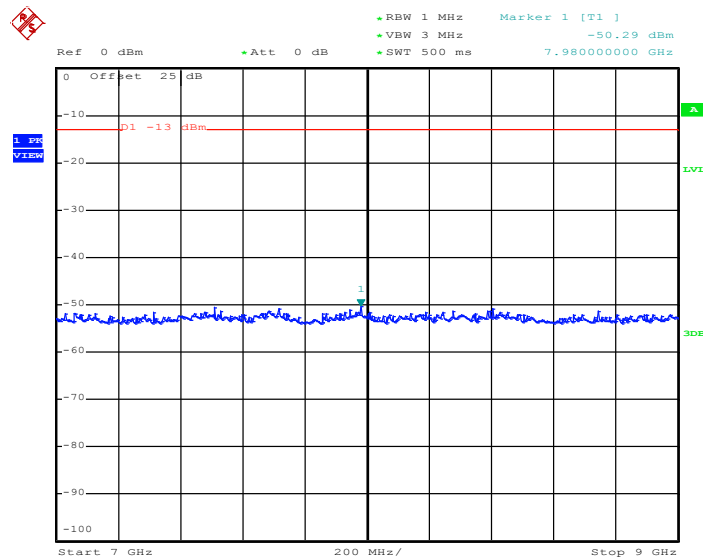

Date: 29.APR.2014 20:01:13



Band :	WCDMA Band V	Channel :	CH4233
Test Mode :	RMC 12.2Kbps Link (QPSK)	Frequency :	846.6 MHz

Conducted Spurious Emission Plot between 30MHz ~ 1GHz

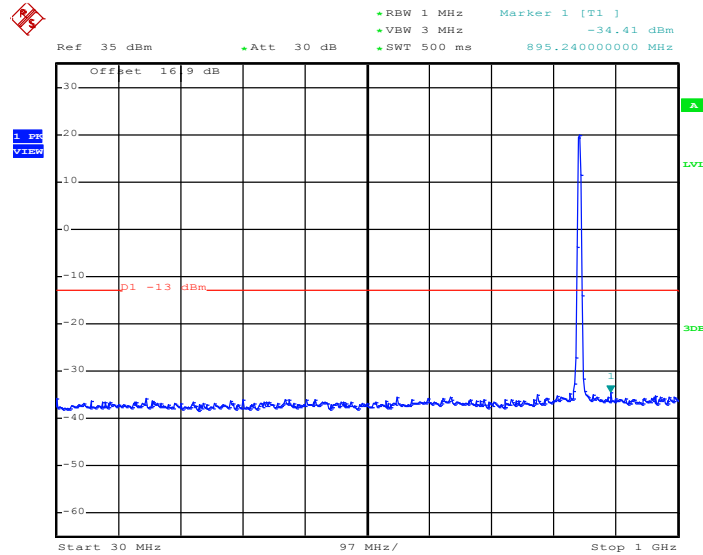

Date: 29.APR.2014 20:04:44

Conducted Spurious Emission Plot between 1GHz ~ 3GHz

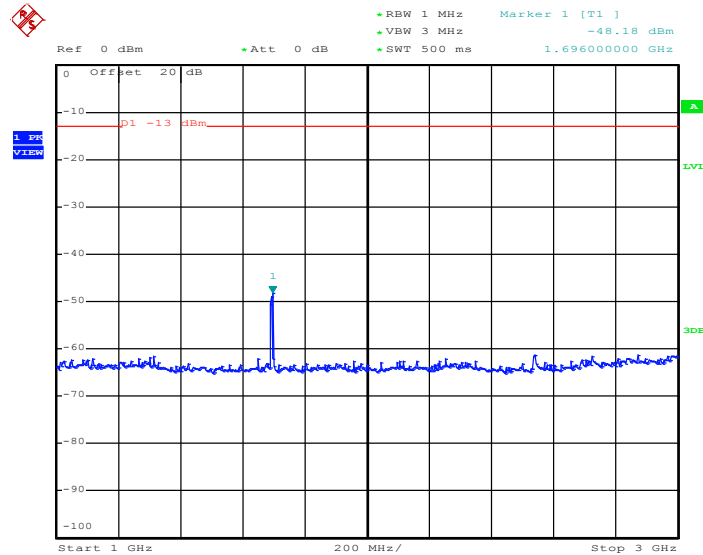

Date: 29.APR.2014 20:05:02



### Conducted Spurious Emission Plot between 3GHz ~ 7GHz

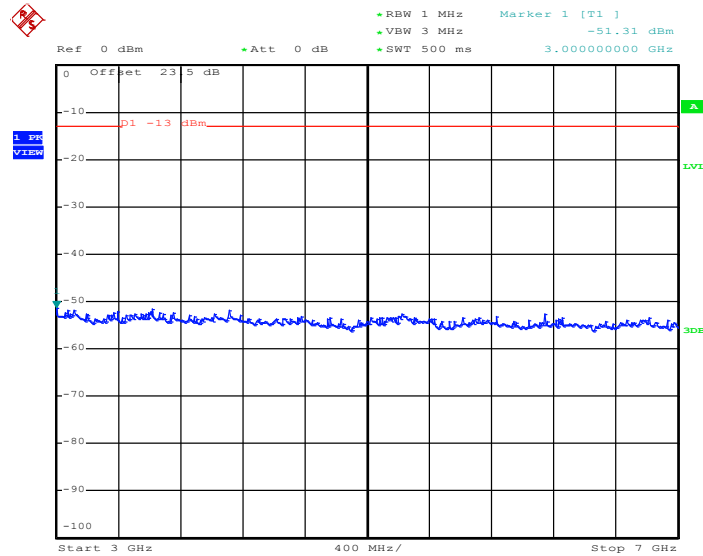

Date: 29.APR.2014 20:05:10

### Conducted Spurious Emission Plot between 7GHz ~ 9GHz

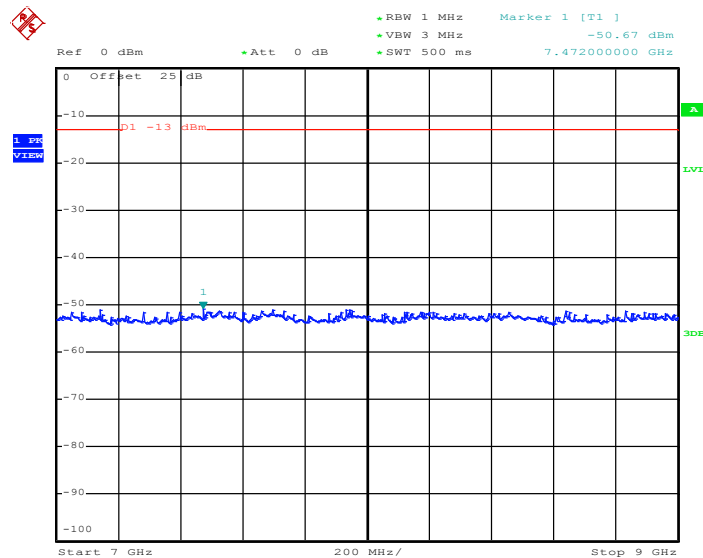

Date: 29.APR.2014 20:05:19



### 3.7 Field Strength of Spurious Radiation Measurement

#### 3.7.1 Description of Field Strength of Spurious Radiated Measurement

The power of any emission outside of the authorized operating frequency ranges must be attenuated below the transmitter power (P) by a factor of at least  $43 + 10 \log (P)$  dB. The spectrum is scanned from 30 MHz up to a frequency including its 10th harmonic.

#### 3.7.2 Measuring Instruments

The measuring equipment is listed in the section 4 of this test report.

#### 3.7.3 Test Procedures

1. The EUT was placed on a rotatable wooden table 0.8 meters above the ground.
2. The EUT was set 3 meters from the receiving antenna, which was mounted on the antenna tower.
3. The table was rotated 360 degrees to determine the position of the highest spurious emission.
4. The height of the receiving antenna is varied between one meter and four meters to search for the maximum spurious emission for both horizontal and vertical polarizations.
5. Make the measurement with the spectrum analyzer's RBW = 1MHz, VBW = 3MHz, taking record of maximum spurious emission.
6. A horn antenna was substituted in place of the EUT and was driven by a signal generator.
7. Tune the output power of signal generator to the same emission level with EUT maximum spurious emission.
8. Taking the record of output power at antenna port.
9. Repeat step 7 to step 8 for another polarization.
10.  $EIRP \text{ (dBm)} = S.G. \text{ Power} - Tx \text{ Cable Loss} + Tx \text{ Antenna Gain}$
11.  $ERP \text{ (dBm)} = EIRP - 2.15$
12. The RF fundamental frequency should be excluded against the limit line in the operating frequency band.
13. The limit line is derived from  $43 + 10\log(P)$  dB below the transmitter power P(Watts)  
 $= P(W) - [43 + 10\log(P)] \text{ (dB)}$   
 $= [30 + 10\log(P)] \text{ (dBm)} - [43 + 10\log(P)] \text{ (dB)}$   
 $= -13\text{dBm}.$

### 3.7.4 Test Setup

For radiated emissions from 30MHz to 1GHz

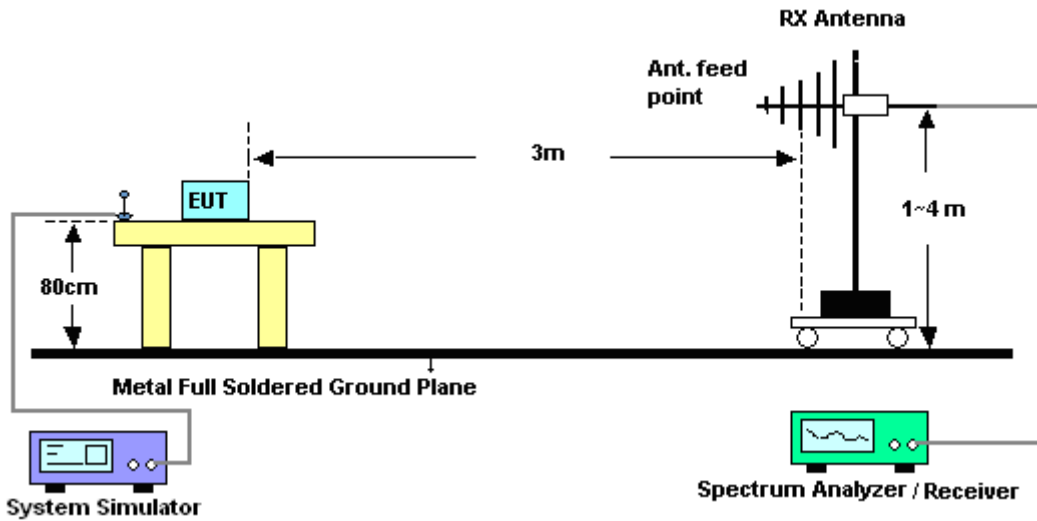

For radiated emissions above 1GHz

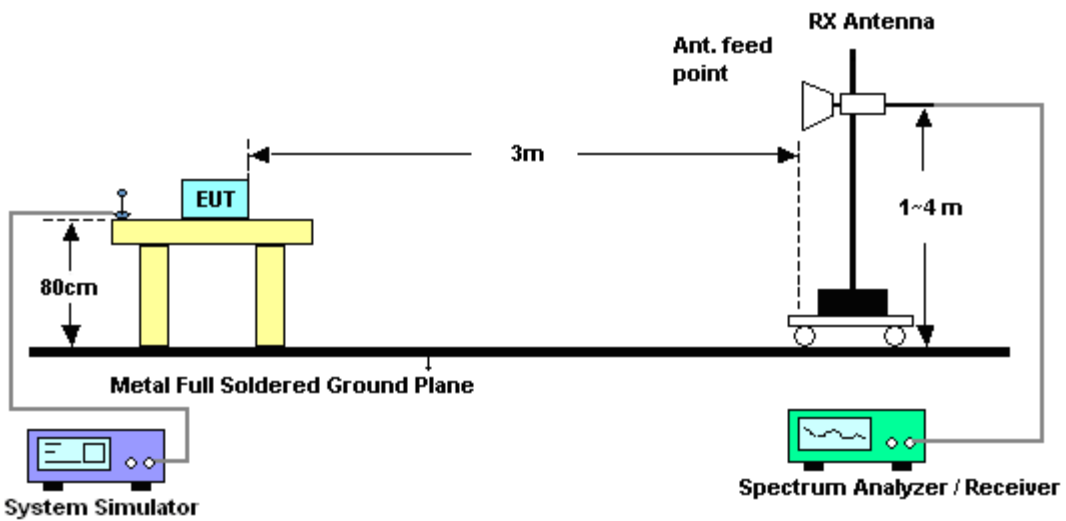



3.7.5 Test Result of Field Strength of Spurious Radiated

<Low Channel>

Band :	GSM850	Temperature :	22~24°C
Test Mode :	GSM Link (GMSK)	Relative Humidity :	42~44%
Test Engineer :	Eric Shih	Polarization :	Horizontal
Remark :	Spurious emissions within 30-1000MHz were found more than 20dB below limit line.		

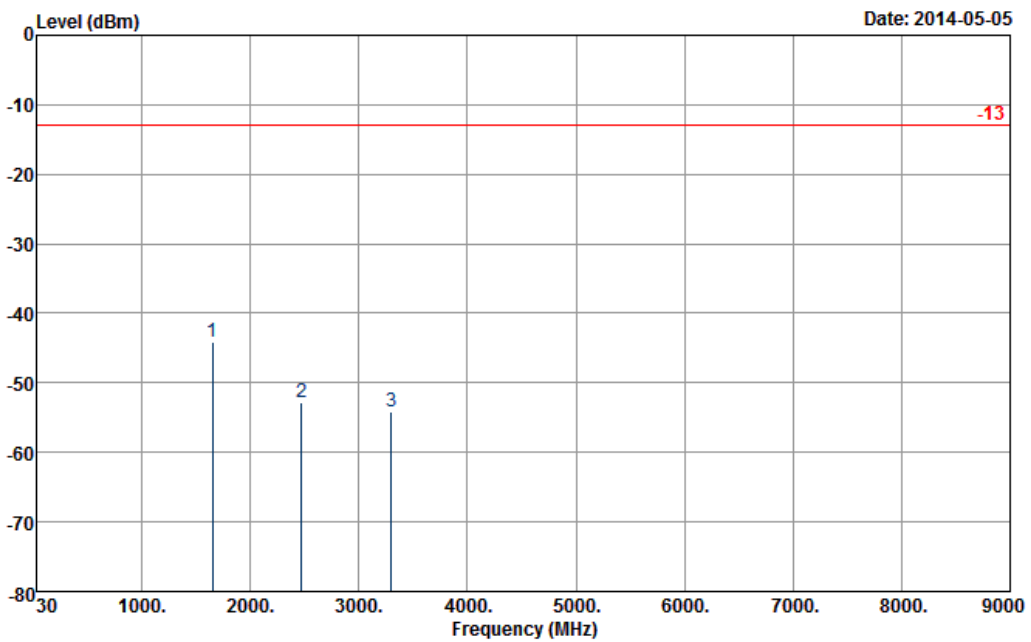

Site : 03CH07-HY  
 Condition : -13 HF-EIRP(080306) HORIZONTAL  
 Project : FG 442481

Frequency ( MHz )	ERP ( dBm )	Limit ( dBm )	Over Limit ( dB )	SPA Reading ( dBm )	S.G. Power ( dBm )	TX Cable loss ( dB )	TX Antenna Gain ( dBi )	Polarization ( H/V )	Result
1649	-44.02	-13	-31.02	-52.74	-48.02	1.53	5.53	H	Pass
2474	-52.75	-13	-39.75	-65.82	-56.84	2.06	6.15	H	Pass
3298	-54.17	-13	-41.17	-68.05	-59.62	2.48	7.93	H	Pass



<b>Band :</b>	GSM850	<b>Temperature :</b>	22~24°C
<b>Test Mode :</b>	GSM Link (GMSK)	<b>Relative Humidity :</b>	42~44%
<b>Test Engineer :</b>	Eric Shih	<b>Polarization :</b>	Vertical
<b>Remark :</b>	Spurious emissions within 30-1000MHz were found more than 20dB below limit line.		

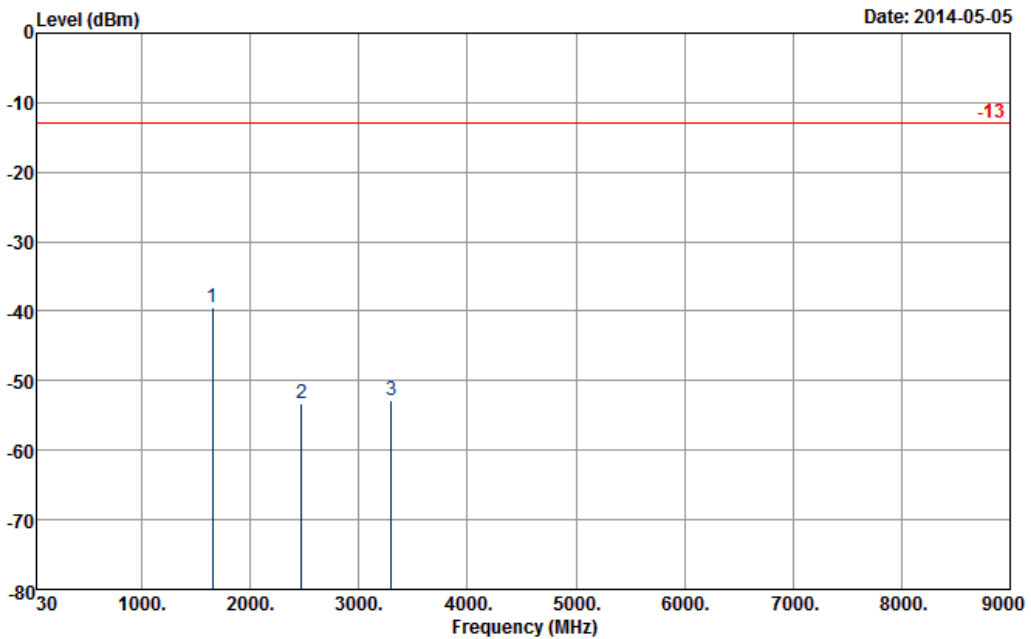

Site : 03CH07-HY  
 Condition : -13 HF-EIRP(080306) VERTICAL  
 Project : FG 442481

Frequency ( MHz )	ERP ( dBm )	Limit ( dBm )	Over Limit ( dB )	SPA Reading ( dBm )	S.G. Power ( dBm )	TX Cable loss ( dB )	TX Antenna Gain ( dBi )	Polarization ( H/V )	Result
1649	-39.35	-13	-26.35	-49.8	-43.35	1.53	5.53	V	Pass
2474	-53.15	-13	-40.15	-66.52	-57.24	2.06	6.15	V	Pass
3298	-52.81	-13	-39.81	-68.31	-58.26	2.48	7.93	V	Pass



<Middle Channel>

Band :	GSM850	Temperature :	22~24°C
Test Mode :	GSM Link (GMSK)	Relative Humidity :	42~44%
Test Engineer :	Eric Shih	Polarization :	Horizontal
Remark :	Spurious emissions within 30-1000MHz were found more than 20dB below limit line.		

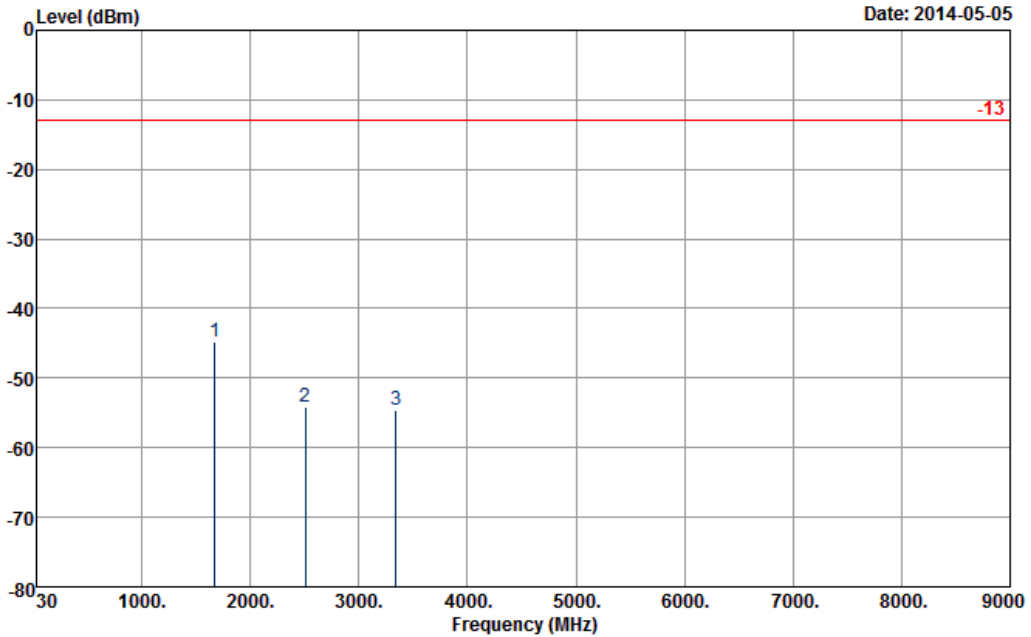

Site : 03CH07-HY  
 Condition : -13 HF-EIRP(080306) HORIZONTAL  
 Project : FG 442481

Frequency ( MHz )	ERP ( dBm )	Limit ( dBm )	Over Limit ( dB )	SPA Reading ( dBm )	S.G. Power ( dBm )	TX Cable loss ( dB )	TX Antenna Gain ( dBi )	Polarization ( H/V )	Result
1672	-44.88	-13	-31.88	-53.22	-48.75	1.62	5.49	H	Pass
2509	-54.08	-13	-41.08	-67.42	-58.2	2.1	6.22	H	Pass
3345	-54.56	-13	-41.56	-68.3	-59.6	3.03	8.07	H	Pass



<b>Band :</b>	GSM850	<b>Temperature :</b>	22~24°C
<b>Test Mode :</b>	GSM Link (GMSK)	<b>Relative Humidity :</b>	42~44%
<b>Test Engineer :</b>	Eric Shih	<b>Polarization :</b>	Vertical
<b>Remark :</b>	Spurious emissions within 30-1000MHz were found more than 20dB below limit line.		

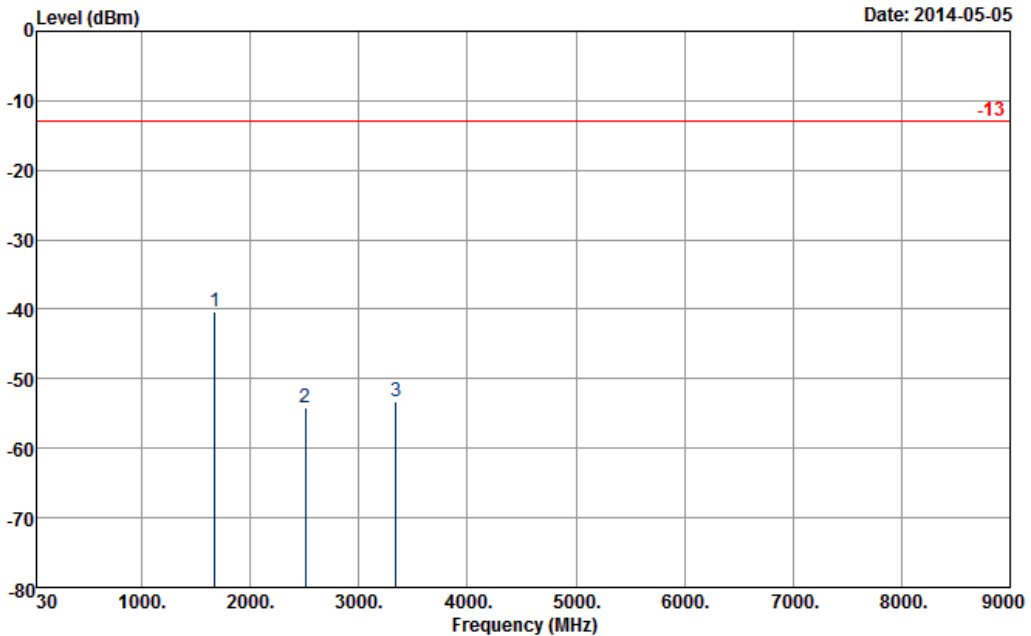

Site : 03CH07-HY  
 Condition : -13 HF-EIRP(080306) VERTICAL  
 Project : FG 442481

Frequency ( MHz )	ERP ( dBm )	Limit ( dBm )	Over Limit ( dB )	SPA Reading ( dBm )	S.G. Power ( dBm )	TX Cable loss ( dB )	TX Antenna Gain ( dBi )	Polarization ( H/V )	Result
1672	-40.38	-13	-27.38	-51.13	-44.25	1.62	5.49	V	Pass
2509	-54.13	-13	-41.13	-67.44	-58.25	2.1	6.22	V	Pass
3345	-53.19	-13	-40.19	-68.66	-58.23	3.03	8.07	V	Pass



<High Channel>

<b>Band :</b>	GSM850	<b>Temperature :</b>	22~24°C
<b>Test Mode :</b>	GSM Link (GMSK)	<b>Relative Humidity :</b>	42~44%
<b>Test Engineer :</b>	Eric Shih	<b>Polarization :</b>	Horizontal
<b>Remark :</b>	Spurious emissions within 30-1000MHz were found more than 20dB below limit line.		

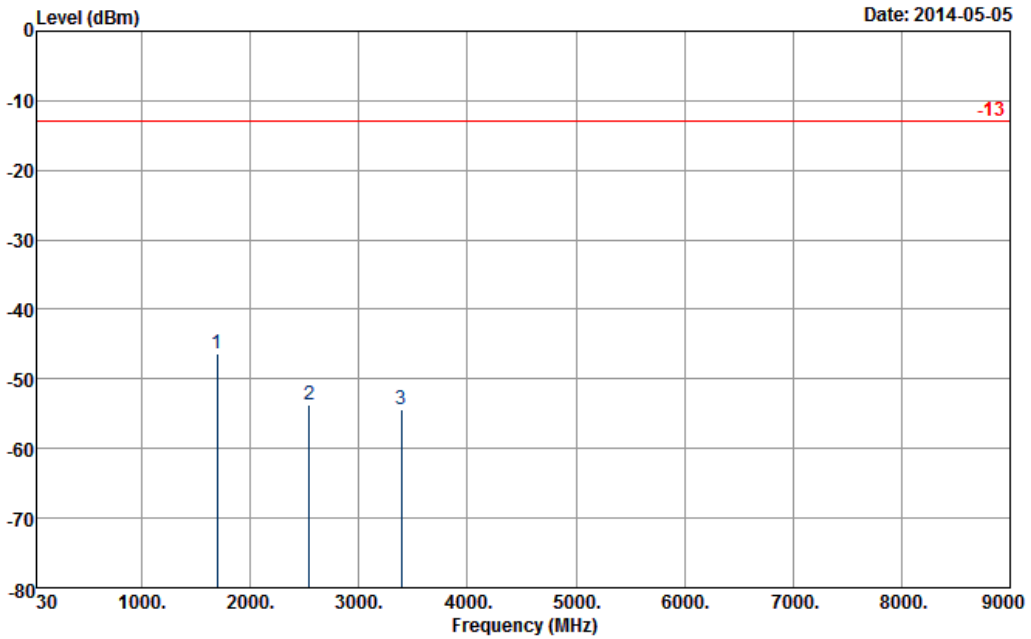

Site : 03CH07-HY  
 Condition : -13 HF-EIRP(080306) HORIZONTAL  
 Project : FG 442481

Frequency ( MHz )	ERP ( dBm )	Limit ( dBm )	Over Limit ( dB )	SPA Reading ( dBm )	S.G. Power ( dBm )	TX Cable loss ( dB )	TX Antenna Gain ( dBi )	Polarization ( H/V )	Result
1696	-46.36	-13	-33.36	-55.29	-50.24	1.57	5.45	H	Pass
2544	-53.60	-13	-40.60	-66.77	-57.86	2.02	6.28	H	Pass
3393	-54.42	-13	-41.42	-68.27	-60.32	2.3	8.20	H	Pass



<b>Band :</b>	GSM850	<b>Temperature :</b>	22~24°C
<b>Test Mode :</b>	GSM Link (GMSK)	<b>Relative Humidity :</b>	42~44%
<b>Test Engineer :</b>	Eric Shih	<b>Polarization :</b>	Vertical
<b>Remark :</b>	Spurious emissions within 30-1000MHz were found more than 20dB below limit line.		

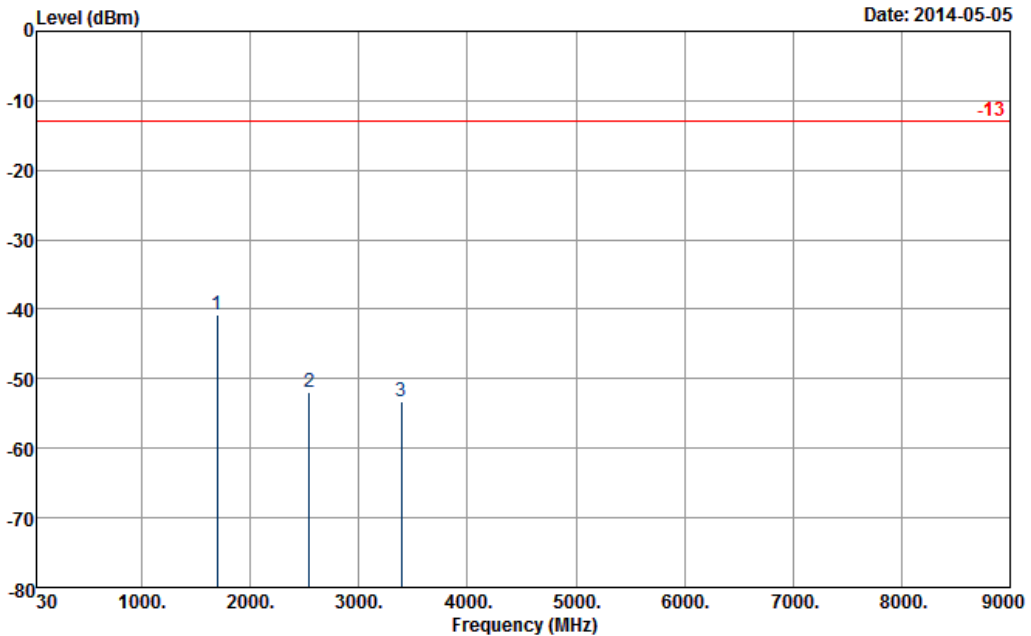

Site : 03CH07-HY  
 Condition : -13 HF-EIRP(080306) VERTICAL  
 Project : FG 442481

Frequency ( MHz )	ERP ( dBm )	Limit ( dBm )	Over Limit ( dB )	SPA Reading ( dBm )	S.G. Power ( dBm )	TX Cable loss ( dB )	TX Antenna Gain ( dBi )	Polarization ( H/V )	Result
1696	-40.87	-13	-27.87	-51.51	-44.75	1.57	5.45	V	Pass
2544	-51.93	-13	-38.93	-65.75	-56.19	2.02	6.28	V	Pass
3393	-53.34	-13	-40.34	-68.65	-59.24	2.3	8.20	V	Pass



<Low Channel>

Band :	GSM1900	Temperature :	22~24°C
Test Mode :	GSM Link (GMSK)	Relative Humidity :	42~44%
Test Engineer :	Eric Shih	Polarization :	Horizontal
Remark :	Spurious emissions within 30-1000MHz were found more than 20dB below limit line.		

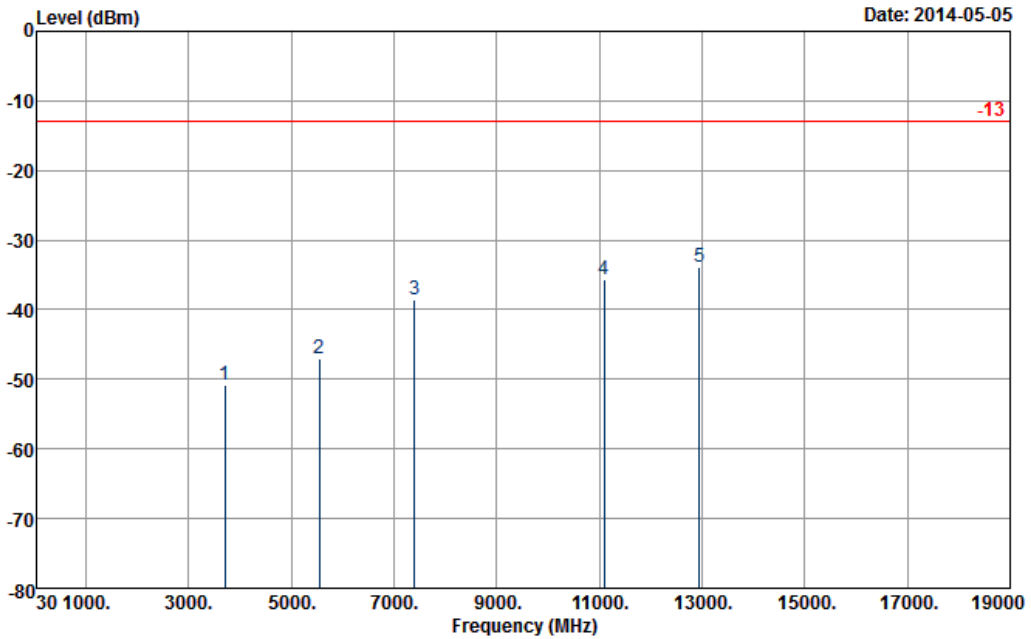

Site : 03CH07-HY  
 Condition : -13 HF-EIRP(080306) HORIZONTAL  
 Project : FG 442481

Frequency ( MHz )	EIRP ( dBm )	Limit ( dBm )	Over Limit ( dB )	SPA Reading ( dBm )	S.G. Power ( dBm )	TX Cable loss ( dB )	TX Antenna Gain ( dBi )	Polarization ( H/V )	Result
3700	-50.86	-13	-37.86	-66.03	-57.01	2.59	8.74	H	Pass
5548	-46.97	-13	-33.97	-67.43	-54.63	3.04	10.70	H	Pass
7403	-38.48	-13	-25.48	-65.82	-47.22	3.28	12.02	H	Pass
11098	-35.62	-13	-22.62	-64.73	-44.44	4.42	13.24	H	Pass
12952	-33.85	-13	-20.85	-67.15	-42.51	4.89	13.55	H	Pass



<b>Band :</b>	GSM1900	<b>Temperature :</b>	22~24°C
<b>Test Mode :</b>	GSM Link (GMSK)	<b>Relative Humidity :</b>	42~44%
<b>Test Engineer :</b>	Eric Shih	<b>Polarization :</b>	Vertical
<b>Remark :</b>	Spurious emissions within 30-1000MHz were found more than 20dB below limit line.		

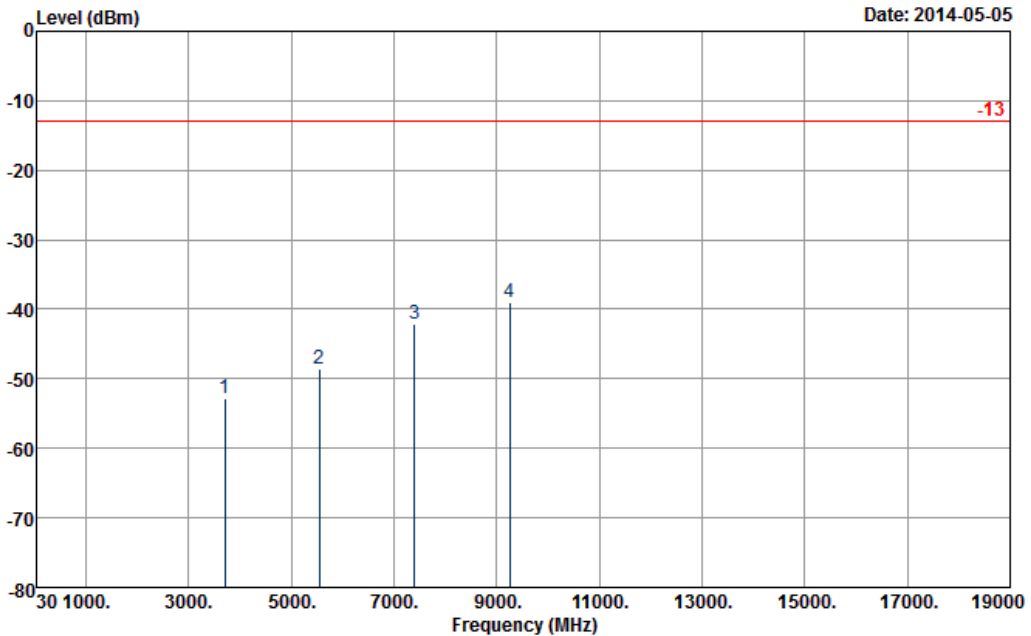

Site : 03CH07-HY  
 Condition : -13 HF-EIRP(080306) VERTICAL  
 Project : FG 442481

Frequency ( MHz )	EIRP ( dBm )	Limit ( dBm )	Over Limit ( dB )	SPA Reading ( dBm )	S.G. Power ( dBm )	TX Cable loss ( dB )	TX Antenna Gain ( dBi )	Polarization ( H/V )	Result
3700	-52.88	-13	-39.88	-69	-59.03	2.59	8.74	V	Pass
5548	-48.68	-13	-35.68	-69	-56.34	3.04	10.70	V	Pass
7403	-42.20	-13	-29.20	-69.18	-50.94	3.28	12.02	V	Pass
9251	-39.07	-13	-26.07	-65.16	-48.37	3.9	13.20	V	Pass



<Middle Channel>

<b>Band :</b>	GSM1900	<b>Temperature :</b>	22~24°C
<b>Test Mode :</b>	GSM Link (GMSK)	<b>Relative Humidity :</b>	42~44%
<b>Test Engineer :</b>	Eric Shih	<b>Polarization :</b>	Horizontal
<b>Remark :</b>	Spurious emissions within 30-1000MHz were found more than 20dB below limit line.		

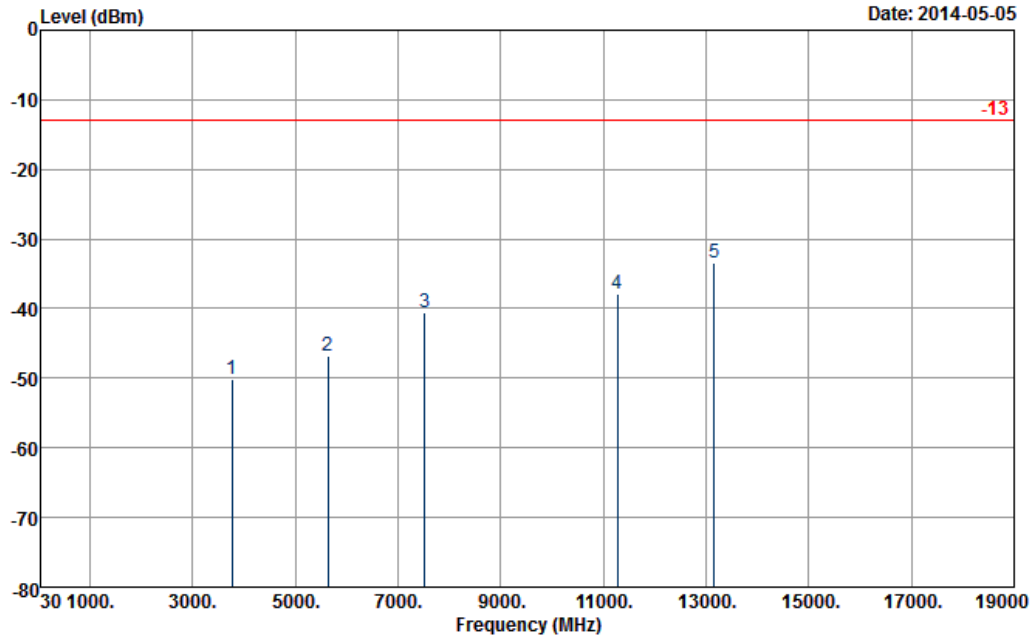

Site : 03CH07-HY  
 Condition : -13 HF-EIRP(080306) HORIZONTAL  
 Project : FG 442481

Frequency ( MHz )	EIRP ( dBm )	Limit ( dBm )	Over Limit ( dB )	SPA Reading ( dBm )	S.G. Power ( dBm )	TX Cable loss ( dB )	TX Antenna Gain ( dBi )	Polarization ( H/V )	Result
3756	-50.11	-13	-37.11	-65.46	-56.41	2.51	8.81	H	Pass
5639	-46.84	-13	-33.84	-67.57	-54.55	2.99	10.70	H	Pass
7522	-40.59	-13	-27.59	-67.82	-49.12	3.59	12.12	H	Pass
11278	-37.85	-13	-24.85	-67.35	-46.89	4.27	13.31	H	Pass
13159	-33.36	-13	-20.36	-66.84	-42.88	4.27	13.79	H	Pass



<b>Band :</b>	GSM1900	<b>Temperature :</b>	22~24°C
<b>Test Mode :</b>	GSM Link (GMSK)	<b>Relative Humidity :</b>	42~44%
<b>Test Engineer :</b>	Eric Shih	<b>Polarization :</b>	Vertical
<b>Remark :</b>	Spurious emissions within 30-1000MHz were found more than 20dB below limit line.		

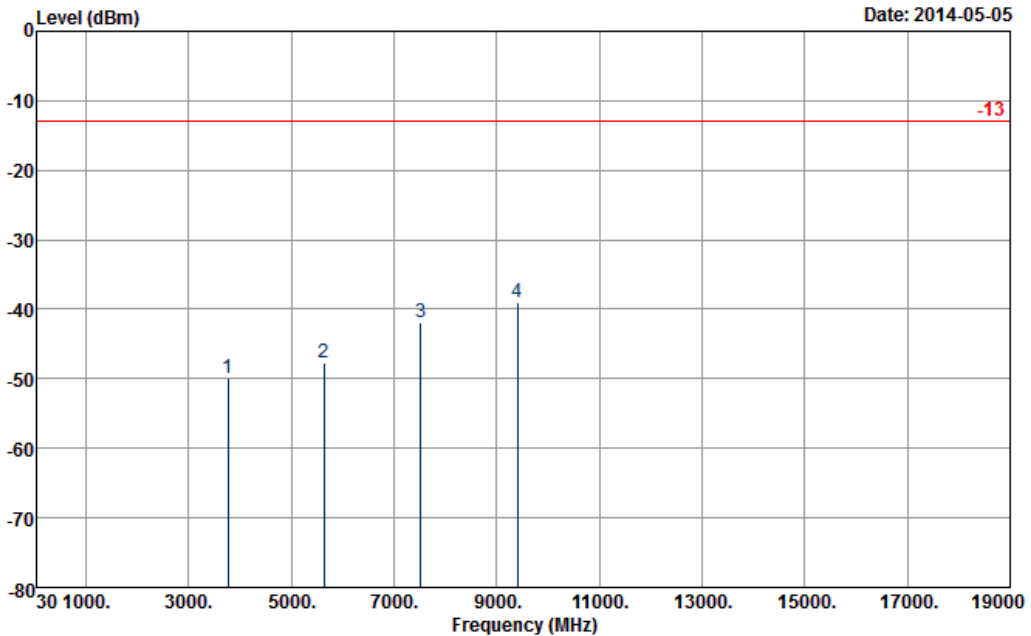

Site : 03CH07-HY  
 Condition : -13 HF-EIRP(080306) VERTICAL  
 Project : FG 442481

Frequency ( MHz )	EIRP ( dBm )	Limit ( dBm )	Over Limit ( dB )	SPA Reading ( dBm )	S.G. Power ( dBm )	TX Cable loss ( dB )	TX Antenna Gain ( dBi )	Polarization ( H/V )	Result
3756	-49.90	-13	-36.90	-66.2	-56.2	2.51	8.81	V	Pass
5639	-47.70	-13	-34.70	-68.29	-55.41	2.99	10.70	V	Pass
7522	-41.94	-13	-28.94	-68.94	-50.47	3.59	12.12	V	Pass
9398	-38.91	-13	-25.91	-65.23	-48.01	4.1	13.20	V	Pass



<High Channel>

Band :	GSM1900	Temperature :	22~24°C
Test Mode :	GSM Link (GMSK)	Relative Humidity :	42~44%
Test Engineer :	Eric Shih	Polarization :	Horizontal
Remark :	Spurious emissions within 30-1000MHz were found more than 20dB below limit line.		

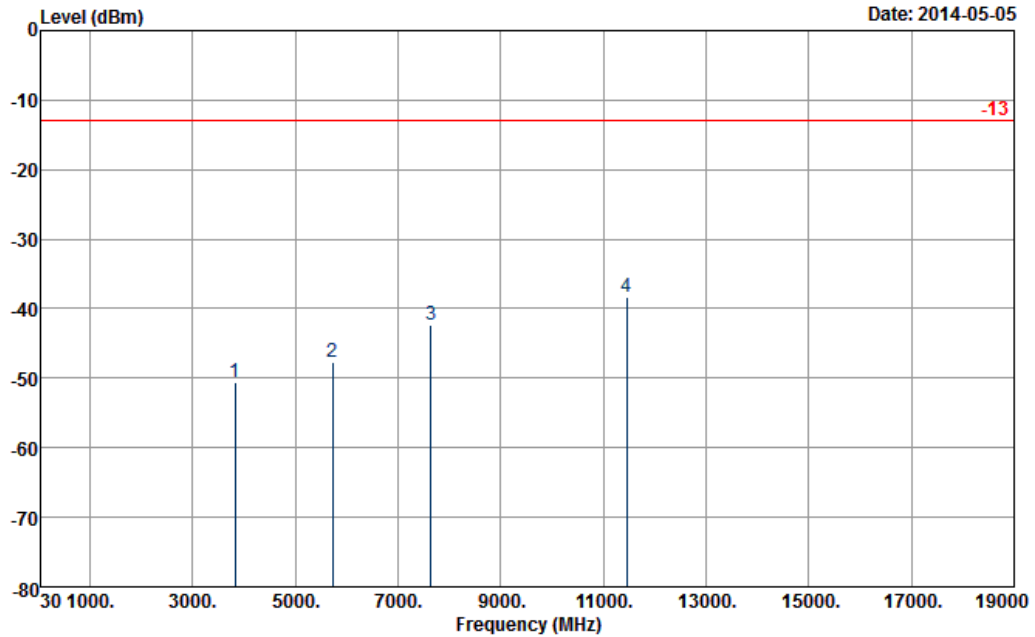

Site : 03CH07-HY  
 Condition : -13 HF-EIRP(080306) HORIZONTAL  
 Project : FG 442481

Frequency ( MHz )	EIRP ( dBm )	Limit ( dBm )	Over Limit ( dB )	SPA Reading ( dBm )	S.G. Power ( dBm )	TX Cable loss ( dB )	TX Antenna Gain ( dBi )	Polarization ( H/V )	Result
3819	-50.48	-13	-37.48	-65.97	-56.89	2.47	8.88	H	Pass
5730	-47.66	-13	-34.66	-68.75	-55.36	3	10.70	H	Pass
7641	-42.36	-13	-29.36	-68.73	-51.14	3.43	12.21	H	Pass
11458	-38.34	-13	-25.34	-67.99	-47.28	4.44	13.38	H	Pass



<b>Band :</b>	GSM1900	<b>Temperature :</b>	22~24°C
<b>Test Mode :</b>	GSM Link (GMSK)	<b>Relative Humidity :</b>	42~44%
<b>Test Engineer :</b>	Eric Shih	<b>Polarization :</b>	Vertical
<b>Remark :</b>	Spurious emissions within 30-1000MHz were found more than 20dB below limit line.		

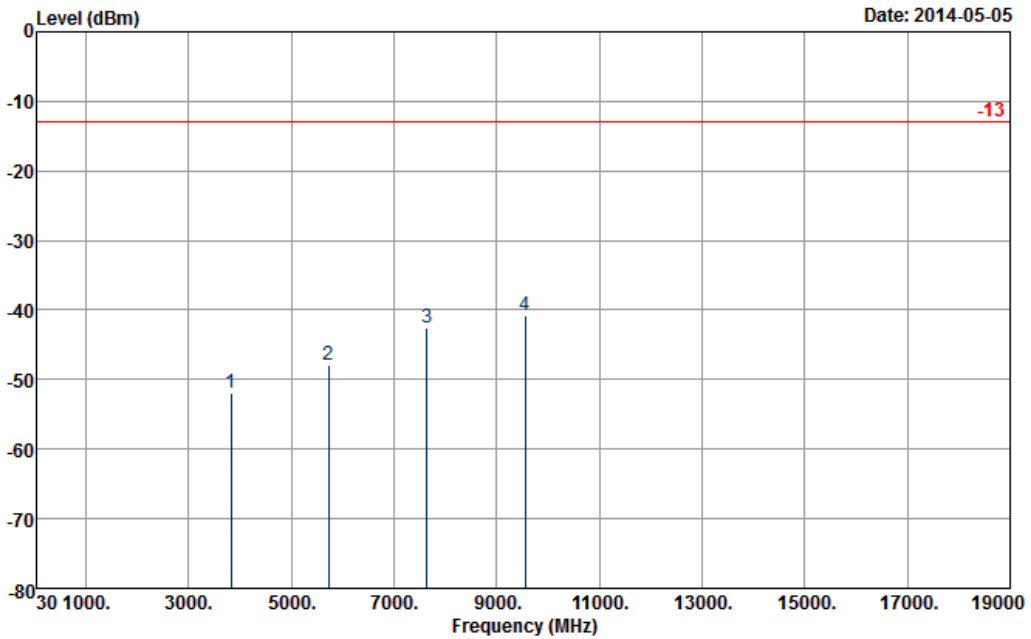

Site : 03CH07-HY  
 Condition : -13 HF-EIRP(080306) VERTICAL  
 Project : FG 442481

Frequency ( MHz )	EIRP ( dBm )	Limit ( dBm )	Over Limit ( dB )	SPA Reading ( dBm )	S.G. Power ( dBm )	TX Cable loss ( dB )	TX Antenna Gain ( dBi )	Polarization ( H/V )	Result
3819	-51.91	-13	-38.91	-68.48	-58.32	2.47	8.88	V	Pass
5730	-47.81	-13	-34.81	-68.72	-55.51	3	10.70	V	Pass
7641	-42.48	-13	-29.48	-68.83	-51.26	3.43	12.21	V	Pass
9552	-40.79	-13	-27.79	-67.26	-50	3.99	13.20	V	Pass



<Low Channel>

<b>Band :</b>	WCDMA Band V	<b>Temperature :</b>	22~24°C
<b>Test Mode :</b>	RMC 12.2Kbps Link (QPSK)	<b>Relative Humidity :</b>	42~44%
<b>Test Engineer :</b>	Eric Shih	<b>Polarization :</b>	Horizontal
<b>Remark :</b>	Spurious emissions within 30-1000MHz were found more than 20dB below limit line.		

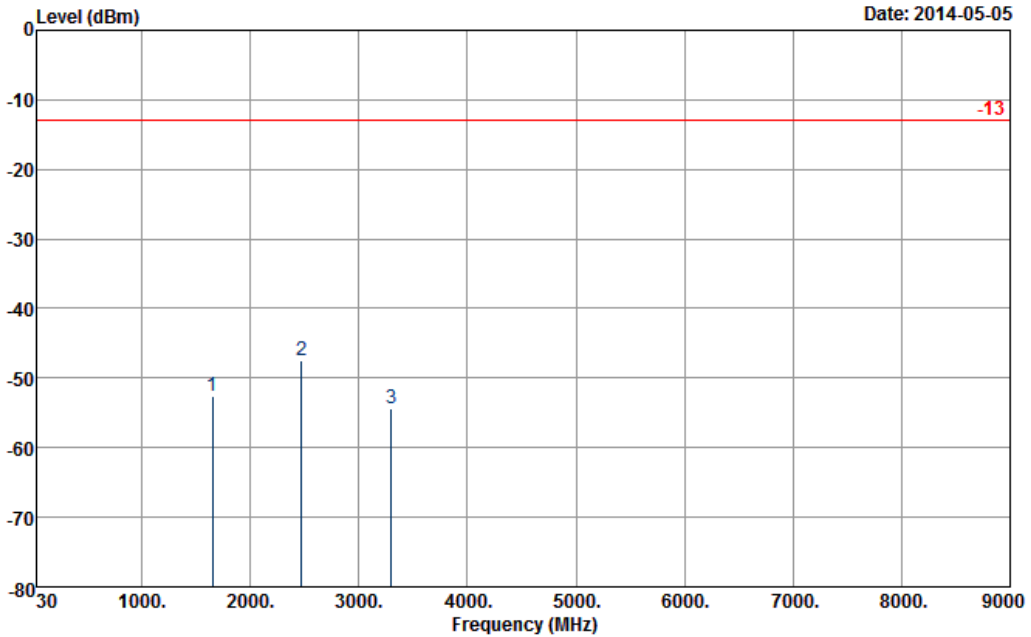

Site : 03CH07-HY  
 Condition : -13 HF-EIRP(080306) HORIZONTAL  
 Project : FG 442481

Frequency ( MHz )	ERP ( dBm )	Limit ( dBm )	Over Limit ( dB )	SPA Reading ( dBm )	S.G. Power ( dBm )	TX Cable loss ( dB )	TX Antenna Gain ( dBi )	Polarization ( H/V )	Result
1649	-52.62	-13	-39.62	-61.31	-56.62	1.53	5.53	H	Pass
2474	-47.37	-13	-34.37	-60.2	-51.46	2.06	6.15	H	Pass
3298	-54.36	-13	-41.36	-68.19	-59.81	2.48	7.93	H	Pass



<b>Band :</b>	WCDMA Band V	<b>Temperature :</b>	22~24°C
<b>Test Mode :</b>	RMC 12.2Kbps Link (QPSK)	<b>Relative Humidity :</b>	42~44%
<b>Test Engineer :</b>	Eric Shih	<b>Polarization :</b>	Vertical
<b>Remark :</b>	Spurious emissions within 30-1000MHz were found more than 20dB below limit line.		

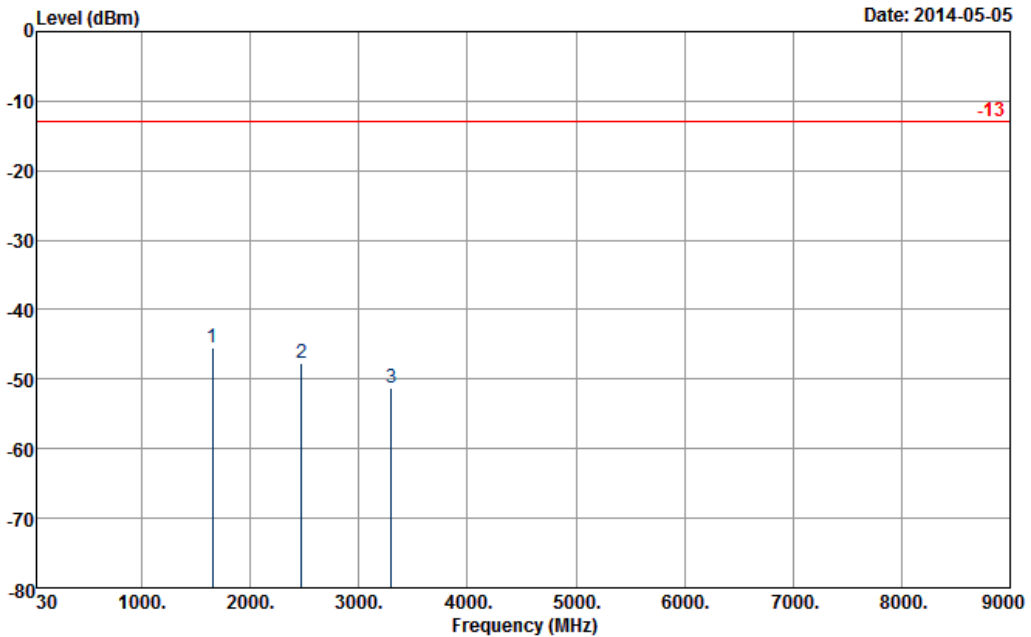

Site : 03CH07-HY  
 Condition : -13 HF-EIRP(080306) VERTICAL  
 Project : FG 442481

Frequency ( MHz )	ERP ( dBm )	Limit ( dBm )	Over Limit ( dB )	SPA Reading ( dBm )	S.G. Power ( dBm )	TX Cable loss ( dB )	TX Antenna Gain ( dBi )	Polarization ( H/V )	Result
1649	-45.38	-13	-32.38	-56.59	-49.38	1.53	5.53	V	Pass
2474	-47.63	-13	-34.63	-61.13	-51.72	2.06	6.15	V	Pass
3298	-51.19	-13	-38.19	-67.43	-56.64	2.48	7.93	V	Pass



<Middle Channel>

<b>Band :</b>	WCDMA Band V	<b>Temperature :</b>	22~24°C
<b>Test Mode :</b>	RMC 12.2Kbps Link (QPSK)	<b>Relative Humidity :</b>	42~44%
<b>Test Engineer :</b>	Eric Shih	<b>Polarization :</b>	Horizontal
<b>Remark :</b>	Spurious emissions within 30-1000MHz were found more than 20dB below limit line.		

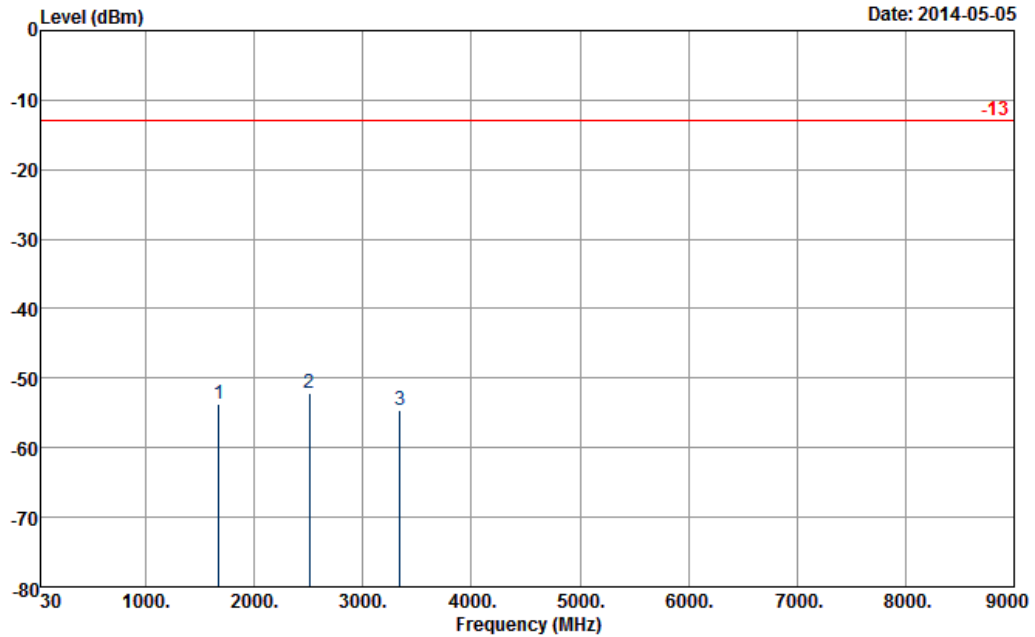

Site : 03CH07-HY  
 Condition : -13 HF-EIRP(080306) HORIZONTAL  
 Project : FG 442481

Frequency ( MHz )	ERP ( dBm )	Limit ( dBm )	Over Limit ( dB )	SPA Reading ( dBm )	S.G. Power ( dBm )	TX Cable loss ( dB )	TX Antenna Gain ( dBi )	Polarization ( H/V )	Result
1672	-53.78	-13	-40.78	-61.98	-57.65	1.62	5.49	H	Pass
2509	-52.24	-13	-39.24	-65.41	-56.36	2.1	6.22	H	Pass
3345	-54.67	-13	-41.67	-68.89	-59.71	3.03	8.07	H	Pass



<b>Band :</b>	WCDMA Band V	<b>Temperature :</b>	22~24°C
<b>Test Mode :</b>	RMC 12.2Kbps Link (QPSK)	<b>Relative Humidity :</b>	42~44%
<b>Test Engineer :</b>	Eric Shih	<b>Polarization :</b>	Vertical
<b>Remark :</b>	Spurious emissions within 30-1000MHz were found more than 20dB below limit line.		

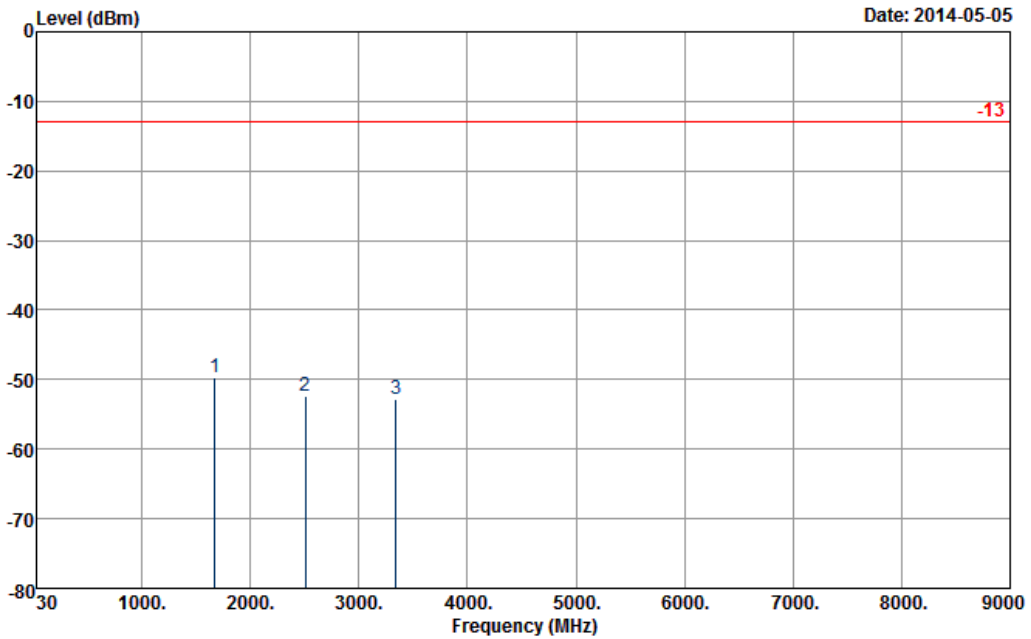

Site : 03CH07-HY  
 Condition : -13 HF-EIRP(080306) VERTICAL  
 Project : FG 442481

Frequency ( MHz )	ERP ( dBm )	Limit ( dBm )	Over Limit ( dB )	SPA Reading ( dBm )	S.G. Power ( dBm )	TX Cable loss ( dB )	TX Antenna Gain ( dBi )	Polarization ( H/V )	Result
1672	-49.61	-13	-36.61	-60.38	-53.48	1.62	5.49	V	Pass
2509	-52.44	-13	-39.44	-65.78	-56.56	2.1	6.22	V	Pass
3345	-52.91	-13	-39.91	-67.73	-57.95	3.03	8.07	V	Pass



<High Channel>

<b>Band :</b>	WCDMA Band V	<b>Temperature :</b>	22~24°C
<b>Test Mode :</b>	RMC 12.2Kbps Link (QPSK)	<b>Relative Humidity :</b>	42~44%
<b>Test Engineer :</b>	Eric Shih	<b>Polarization :</b>	Horizontal
<b>Remark :</b>	Spurious emissions within 30-1000MHz were found more than 20dB below limit line.		

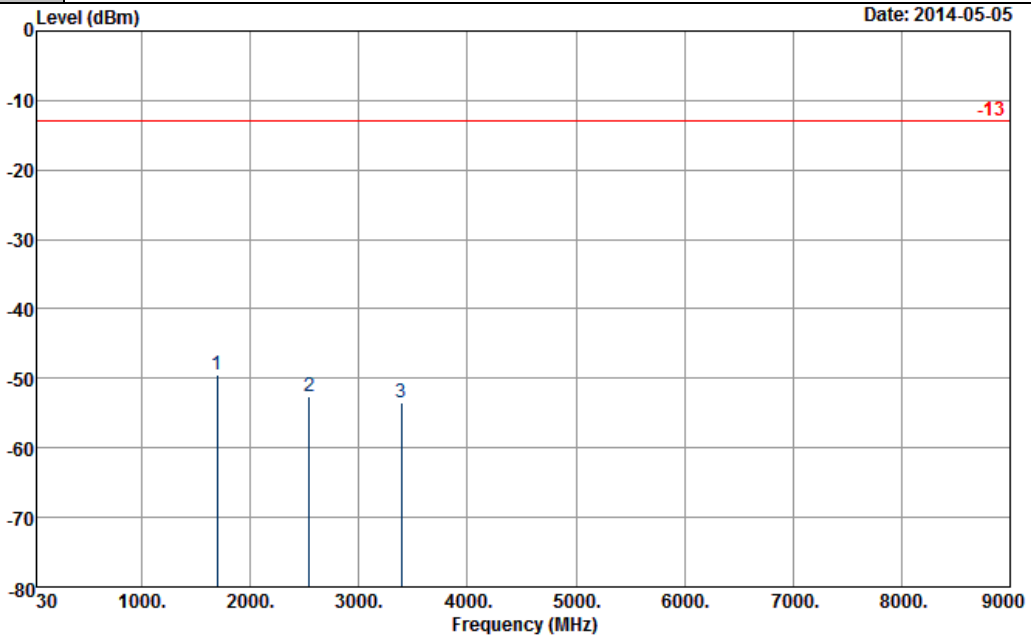

Site : 03CH07-HY  
 Condition : -13 HF-EIRP(080306) HORIZONTAL  
 Project : FG 442481

Frequency ( MHz )	ERP ( dBm )	Limit ( dBm )	Over Limit ( dB )	SPA Reading ( dBm )	S.G. Power ( dBm )	TX Cable loss ( dB )	TX Antenna Gain ( dBi )	Polarization ( H/V )	Result
1696	-49.38	-13	-36.38	-57.85	-53.26	1.57	5.45	H	Pass
2544	-52.65	-13	-39.65	-66.08	-56.91	2.02	6.28	H	Pass
3393	-53.57	-13	-40.57	-68.06	-59.47	2.3	8.20	H	Pass



<b>Band :</b>	WCDMA Band V	<b>Temperature :</b>	22~24°C
<b>Test Mode :</b>	RMC 12.2Kbps Link (QPSK)	<b>Relative Humidity :</b>	42~44%
<b>Test Engineer :</b>	Eric Shih	<b>Polarization :</b>	Vertical
<b>Remark :</b>	Spurious emissions within 30-1000MHz were found more than 20dB below limit line.		

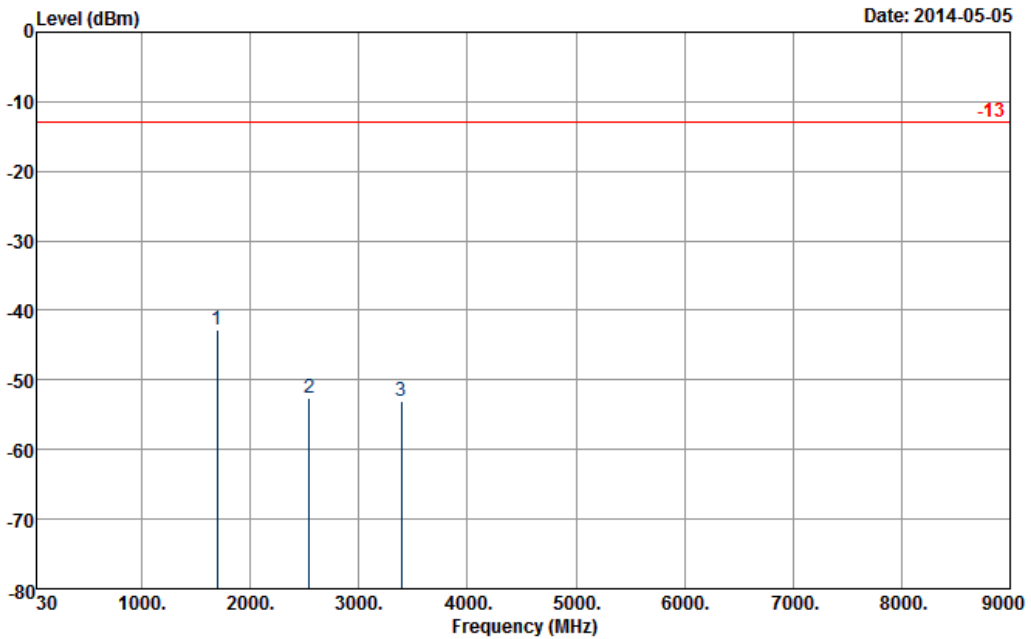

Site : 03CH07-HY  
 Condition : -13 HF-EIRP(080306) VERTICAL  
 Project : FG 442481

Frequency ( MHz )	ERP ( dBm )	Limit ( dBm )	Over Limit ( dB )	SPA Reading ( dBm )	S.G. Power ( dBm )	TX Cable loss ( dB )	TX Antenna Gain ( dBi )	Polarization ( H/V )	Result
1696	-42.74	-13	-29.74	-53.97	-46.62	1.57	5.45	V	Pass
2544	-52.61	-13	-39.61	-66.16	-56.87	2.02	6.28	V	Pass
3393	-53.11	-13	-40.11	-68.43	-59.01	2.3	8.20	V	Pass

## 3.8 Frequency Stability Measurement

### 3.8.1 Description of Frequency Stability Measurement

The frequency stability shall be measured by variation of ambient temperature and variation of primary supply voltage to ensure that the fundamental emission stays within the authorized frequency block. The frequency stability of the transmitter shall be maintained within  $\pm 0.00025\%$  ( $\pm 2.5\text{ppm}$ ) of the center frequency.

### 3.8.2 Measuring Instruments

The measuring equipment is listed in the section 4 of this test report.

### 3.8.3 Test Procedures for Temperature Variation

1. The EUT was set up in the thermal chamber and connected with the system simulator.
2. With power OFF, the temperature was decreased to  $-30^{\circ}\text{C}$  and the EUT was stabilized before testing. Power was applied and the maximum change in frequency was recorded within one minute.
3. With power OFF, the temperature was raised in  $10^{\circ}\text{C}$  steps up to  $50^{\circ}\text{C}$ . The EUT was stabilized at each step for at least half an hour. Power was applied and the maximum frequency change was recorded within one minute.

### 3.8.4 Test Procedures for Voltage Variation

1. The EUT was placed in a temperature chamber at  $25\pm 5^{\circ}\text{C}$  and connected with the system simulator.
2. The power supply voltage to the EUT was varied from BEP to 115% of the nominal value measured at the input to the EUT.
3. The variation in frequency was measured for the worst case.

### 3.8.5 Test Setup

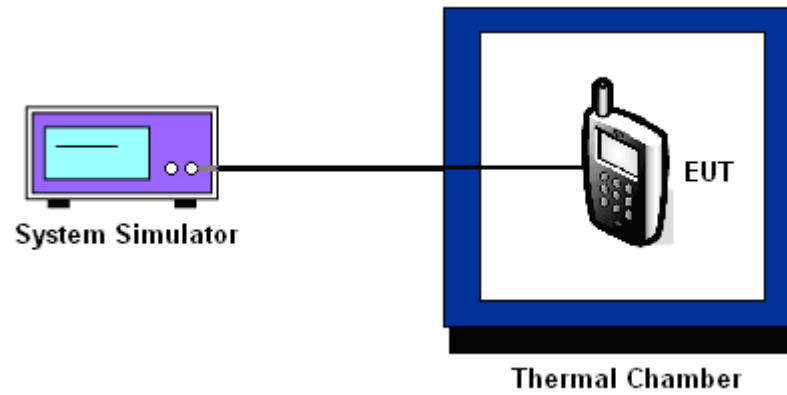



3.8.6 Test Result of Temperature Variation

Band :	GSM 850	Channel :	189
Limit (ppm) :	2.5	Frequency :	836.4 MHz

Temperature (°C)	GSM		Limit (ppm)	Result
	Freq. Dev. (Hz)	Deviation (ppm)		
50	-29	0.03	2.5	PASS
40	-25	0.03		
30	-28	0.03		
20	-27	0.03		
10	-25	0.03		
0	-22	0.03		
-10	-24	0.03		
-20	-27	0.03		
-30	-30	0.04		

Band :	GSM 1900	Channel :	661
Limit (ppm) :	2.5	Frequency :	1880.0 MHz

Temperature (°C)	GSM		Limit (ppm)	Result
	Freq. Dev. (Hz)	Deviation (ppm)		
50	-29	0.02	2.5	PASS
40	-26	0.01		
30	-28	0.01		
20	-29	0.02		
10	-20	0.01		
0	-23	0.01		
-10	-25	0.01		
-20	-26	0.01		
-30	-32	0.02		



<b>Band :</b>	WCDMA Band V	<b>Channel :</b>	4182
<b>Limit (ppm) :</b>	2.5	<b>Frequency :</b>	836.4 MHz

Temperature (°C)	RMC 12.2Kbps		Limit (ppm)	Result
	Freq. Dev. (Hz)	Deviation (ppm)		
50	-10	0.01	2.5	PASS
40	-12	0.01		
30	-9	0.01		
20	-7	0.01		
10	-8	0.01		
0	-10	0.01		
-10	-13	0.02		
-20	-12	0.01		
-30	-11	0.01		



3.8.7 Test Result of Voltage Variation

Band & Channel	Mode	Voltage (Volt)	Freq. Dev. (Hz)	Deviation (ppm)	Limit (ppm)	Result
GSM 850 CH189	GSM	3.8	-26	0.03	2.5	PASS
		BEP	-27	0.03		
		4.2	-28	0.03		
GSM 1900 CH661	GSM	3.8	-24	0.01		
		BEP	-26	0.01		
		4.2	-29	0.02		
WCDMA Band V CH4182	RMC 12.2Kbps	3.8	-7	0.01		
		BEP	-6	0.01		
		4.2	-9	0.01		

Note:

- 1. Normal Voltage = 3.8V.
- 2. Battery End Point (BEP) = 3.6 V.



## 4 List of Measuring Equipment

Instrument	Manufacturer	Model No.	Serial No.	Characteristics	Calibration Date	Test Date	Due Date	Remark
System Simulator	Rohde & Schwarz	CMU200	117995	N/A	Aug. 01, 2013	Apr. 29, 2014	Jul. 31, 2014	Conducted (TH02-HY)
Spectrum Analyzer	Rohde & Schwarz	FSP40	100055	9kHz~40GHz	Jun. 07, 2013	Apr. 29, 2014	Jun. 06, 2014	Conducted (TH02-HY)
Thermal Chamber	Ten Billion	TTH-D3SP	TBN-930701	N/A	Jul. 19, 2013	Apr. 29, 2014	Jul. 18, 2014	Conducted (TH02-HY)
Spectrum Analyzer	Rohde & Schwarz	FSV30	101749	10Hz ~ 30GHz	Feb. 10, 2014	May 05, 2014	Feb. 09, 2015	Radiation (03CH07-HY)
Bilog Antenna	Schaffner	CBL6111C	2726	30MHz ~ 1GHz	Oct. 10, 2013	May 05, 2014	Oct. 09, 2014	Radiation (03CH07-HY)
Double Ridge Horn Antenna	ESCO	3117	75962	1GHz~18GHz	Aug. 22, 2013	May 05, 2014	Aug. 21, 2014	Radiation (03CH07-HY)
Preamplifier	COM-POWER	PA-103A	161241	10 MHz ~ 1000MHz	Mar. 17, 2014	May 05, 2014	Mar. 16, 2015	Radiation (03CH07-HY)
Preamplifier	Agilent	8449B	3008A02362	1 GHz~26.5 GHz	Nov. 29, 2013	May 05, 2014	Nov. 28, 2014	Radiation (03CH07-HY)
Turn Table	ChainTek	ChainTek 3000	N/A	0 ~ 360 degree	N/A	May 05, 2014	N/A	Radiation (03CH07-HY)
Antenna Mast	ChainTek	M-400-0	114/8000604/	N/A	N/A	May 05, 2014	N/A	Radiation (03CH07-HY)
SHF-EHF Horn Antenna	SCHWARZBECK	BBHA 9170	BBHA917025 1	15GHz- 40GHz	Oct. 03, 2013	May 05, 2014	Oct. 02, 2014	Radiation (03CH07-HY)



## 5 Uncertainty of Evaluation

### Uncertainty of Radiated Emission Measurement (30 MHz ~ 1000 MHz)

Measuring Uncertainty for a Level of Confidence of 95% ( $U = 2Uc(y)$ )	4.50
---	------