

EMI CERTIFICATION REPORT

Applicant:

SAMSUNG ELECTRONICS CO., LTD
416. Maetan-3dong, Yeongtong-gu, Suwon-si,
Gyeonggi-do, 442-742, Korea

Date of Issue: May 17, 2011

Test Report No.: HCTE1105FE25

Test Site: HCT CO., LTD.

HCT FRN: 0005-8664-21

FCC ID:

A3LGTS5270L

Rule Part(s) / Standard(s) : FCC PART 15 Subpart B Class B
Equipment Type : 850/1 900 GSM Phone with Bluetooth & WLAN
Trade Name : SAMSUNG ELECTRONICS CO., LTD
Model(s) : GT-S5270L
Port / Connector(s) : USB Data Port / Headset Port

The device bearing the trade name and model specified above, has been shown to comply with the applicable technical standards as indicated in the measurement report and was tested in accordance with the measurement procedures specified in ANSI C63.4-2003. (See Test Report if any modifications were made for compliance)

I attest to the accuracy of data. All measurements reported herein were performed by me or were made under my supervision and are correct to the best of my knowledge and belief. I assume full responsibility for the completeness of these measurements and vouch for the qualifications of all persons taking them.

HCT certifies that no party to application has been subject to a denial of Federal benefits that includes FCC benefits pursuant to Section 5301 of the Anti-Drug Abuse Act of 1988, 21 U.S.C 862



Report prepared by
: Doo Hwan Ryu
Test Engineer of EMC Team

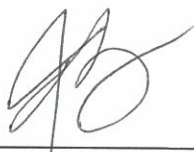

Approved by
: Jin Pyo Hong
Manager of EMC Team

TABLE OF CONTENTS

	PAGE
1. GENERAL INFORMATION	
1.1 Product description	3
1.2 Related submittal(s)/Grant(s)	3
1.3 Tested system details	4
1.4 Cable description	5
1.5 Noise suppression parts on cable. (I/O cable)	5
1.6 Test methodology	6
1.7 Test facility	6
1.8 Frequency Range of Radiated Measurements	6
2. SYSTEM TEST CONFIGURATION	
2.1 Configuration of tested system	7
3. PRELIMINARY TEST	
3.1 Conducted Emission test	8
3.2 Radiated Emission test	8
4. CONDUCTED AND RADIATED EMISSION TESTS SUMMARY	
4.1 Conducted Emission test	9
4.2 Radiated Emission test	14
5. FIELD STRENGTH CALCULATION	15
6. TEST EQUIPMENT	16
7. CONCLUSION	17

ATTACHMENT: TEST SETUP PHOTOGRAPHS

1. GENERAL INFORMATION

1.1 Product Description

Equipment Under Test (E.U.T) is **850/1 900 GSM Phone with Bluetooth & WLAN, Model: GT-S5270L** manufactured by **SAMSUNG ELECTRONICS CO., LTD.** Its basic purpose is used for communications.

Model (s)	GT-S5270L
FCC ID	A3LGTS5270L
E.U.T Type	850/1 900 GSM Phone with Bluetooth & WLAN
TX Frequency	824.20 MHz to 848.80 MHz (GSM 850) 1 850.20 MHz to 1 909.80 MHz (GSM 1 900)
RX Frequency	869.20 MHz to 893.80 MHz (GSM 850) 1 930.20 MHz to 1 989.80 MHz (GSM 1 900)

1.2 Related Submittal(s) / Grant(s)

Original submittal only.

1.3 Tested System Details

All equipment descriptions used in the tested system (including inserted cards) are:

Device Type	Manufacturer	Model Number	FCC ID / DoC	Connected To
850/1 900 GSM Phone with Bluetooth & WLAN	SAMSUNG	GT-S5270L	A3LGTS5270L	Notebook PC
Notebook PC	SAMSUNG	NT-R519	DoC	E.U.T Notebook PC adaptor
Notebook PC adaptor	DELTA (JIANG SU)	SADP-90FH B AD-9019S	-	Notebook PC
Mouse	Microsoft	Intellimouse optical USB and PS/2 compatible	DoC	Notebook PC
Headset	-	-	-	E.U.T
USB cable	-	APCBU12BBE	-	E.U.T Notebook PC
SD card (2 GB)	SanDisk	-	-	E.U.T
Keypad	LG	LK3200	DoC	Notebook PC

1.4 Cable Description

Product Name	Port	Power Cord Shielded (Y/N)	I/O Cable Shielded (Y/N)	Length (m)
850/1 900 GSM Phone with Bluetooth & WLAN	Headset jack	-	N	(D)1.6
	USB data	Y	Y	(P, D)0.7
Notebook PC	USB (Mouse)	-	Y	(D)1.8
	USB (Keypad)	-	Y	(D)0.6

* The marked "(D)" means the data cable and "(P)" means the power cable.

1.5 Noise Suppression Parts on Cable. (I/O cable)

Product Name	Port	Ferrite Bead (Y/N)	Location	Metal Hood (Y/N)	Location
850/1 900 GSM Phone with Bluetooth & WLAN	Headset jack	N	-	Y	E.U.T End
	USB data	N	-	Y	Both End
Notebook PC	USB (Mouse)	Y	Notebook PC End	Y	Notebook PC End
	USB (Keypad)	N	-	Y	Notebook PC End

1.6 Test Methodology

Both Conducted and Radiated testing was performed according to the procedures in ANSI C63.4/2003. Radiated testing was performed at an antenna to E.U.T distance of 3 m

1.7 Test Facility

The 10 m semi anechoic chamber used to collect the test is located at the 105-1, Jangam-Ri, Majang-Myeon, Icheon-Si, Kyoungki-Do, Korea.

Those measurement facilities are constructed in conformance with the requirements of ANSI C63.4. Detailed description of test facilities was submitted to the Commission and accepted dated Sep. 03, 2010 (Registration Number: 90661)

1.8 Frequency Range of Radiated Measurements

An unintentional radiator, including a digital device, the spectrum shall be investigated from the lowest radio frequency signal generated or used in the device, without going below the lowest frequency for which a Radiated Emission limit is specified, up to the frequency shown in the following table

Highest frequency generated or used in the device or on which the device operates or tunes (MHz)	Upper frequency of measurement range (MHz)
Below 1.705	30
1.705 to 108	1 000
108 to 500	2 000
500 to 1 000	5 000
Above 1 000	5 th harmonic of the highest frequency or 40 GHz, whichever is lower

2. SYSTEM TEST CONFIGURATION

2.1 Configuration of Test System

Power Line Conducted test : E.U.T was connected to LISN via Notebook PC adaptor.
Preliminary Power Line Conducted Emission tests were performed by using the procedure in ANSI C63.4/2003 7.2.3 to determine the worst operating conditions.

Radiated Emission test : Preliminary Radiated Emission tests were performed by using the procedure in ANSI C63.4/2003 8.3.1.1 to determine the worst operating condition. Final Radiated Emission tests were performed at 10 m semi-anechoic chamber.

[Configuration of Tested System]

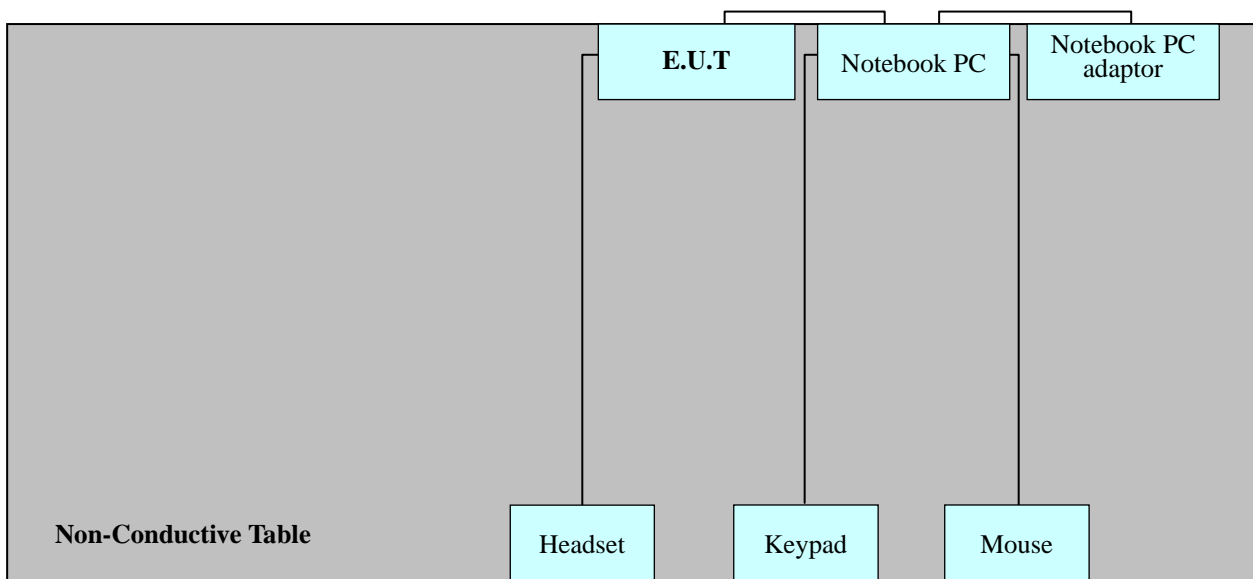

Power Line: 110 VAC

3. PRELIMINARY TEST

3.1 Conducted Emission Test

■ It was tested Data Communication mode, after connecting all peripheral devices.

Operation Mode	The Worst Operating Condition
Data Communication	○

3. 2 Radiated Emission Test

■ It was tested Data Communication mode, after connecting all peripheral devices.

Operation Mode	The Worst Operating Condition
Data Communication	○

4. CONDUCTED AND RADIATED EMISSION TEST SUMMARY

4.1 Conducted Emission Test

The following table shows the highest levels of conducted emissions on both polarization of hot and neutral line.

Limit apply to	: FCC PART 15 Subpart B Class B
Detector	: Quasi-Peak, Average (6 dB Bandwidth: 9 kHz)
Operation Mode	: Data Communication mode
Temperature	: 24.7 °C
Humidity level	: 41.5 %
Test date	: May 14, 2011

※ **NOTE:** Refer to page 10 to page 13 for details.

HCT

EMC

EUT: GT-S5270L
 Manufacturer: SAMSUNG
 Operating Condition: DATA MODE
 Test Site: SHIELD ROOM
 Operator: DH-RYU
 Test Specification: FCC PART 15 CLASS B
 Comment: N

SCAN TABLE: "FCC PART 15 B(N)"

Short Description:			FCC PART 15 CLASS B			
Start Frequency	Stop Frequency	Step Width	Detector	Meas. Time	IF Bandw.	Transducer
150.0 kHz	500.0 kHz	4.0 kHz	MaxPeak	10.0 ms	9 kHz	None
500.0 kHz	5.0 MHz	4.0 kHz	Average	10.0 ms	9 kHz	None
5.0 MHz	30.0 MHz	4.0 kHz	MaxPeak	10.0 ms	9 kHz	None
			Average	10.0 ms	9 kHz	None

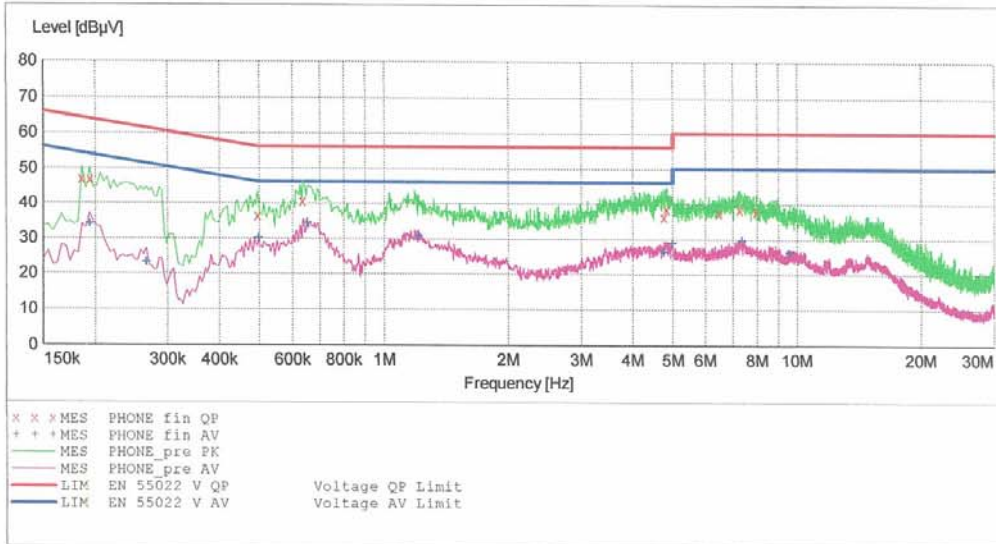

MEASUREMENT RESULT: "PHONE_fin QP"

5/14/2011 10:01AM

Frequency MHz	Level dBµV	Transd dB	Limit dBµV	Margin dB	Line	PE
0.186010	46.80	10.3	64	17.4	---	---
0.194010	46.70	10.3	64	17.2	---	---
0.494010	36.40	10.3	56	19.7	---	---
0.636000	40.60	10.3	56	15.4	---	---
4.764000	36.30	10.7	56	19.7	---	---
4.836000	38.50	10.7	56	17.5	---	---
6.472000	37.30	10.9	60	22.7	---	---
7.264000	38.50	11.0	60	21.5	---	---
7.984000	37.90	11.0	60	22.1	---	---

MEASUREMENT RESULT: "PHONE_fin AV"

5/14/2011 10:01AM

Frequency MHz	Level dBμV	Transd dB	Limit dBμV	Margin dB	Line	PE
0.194010	33.90	10.3	54	20.0	---	---
0.266010	23.20	10.3	51	28.0	---	---
0.498010	29.90	10.3	46	16.1	---	---
0.652000	34.20	10.3	46	11.8	---	---
1.212000	30.60	10.4	46	15.4	---	---
4.768000	26.20	10.7	46	19.8	---	---
5.000000	28.80	10.7	46	17.2	---	---
7.380000	29.50	11.0	50	20.5	---	---
9.596000	26.10	11.0	50	23.9	---	---

HCT

EMC

EUT: GT-S5270L
 Manufacturer: SAMSUNG
 Operating Condition: DATA MODE
 Test Site: SHIELD ROOM
 Operator: DH-RYU
 Test Specification: FCC PART 15 CLASS B
 Comment: H

SCAN TABLE: "FCC PART 15 B(H)"

Short Description:			FCC PART 15 CLASS B			
Start	Stop	Step	Detector	Meas. Time	IF Bandw.	Transducer
150.0 kHz	500.0 kHz	1.0 kHz	MaxPeak	10.0 ms	9 kHz	None
			Average			
500.0 kHz	5.0 MHz	4.0 kHz	MaxPeak	10.0 ms	9 kHz	None
			Average			
5.0 MHz	30.0 MHz	4.0 kHz	MaxPeak	10.0 ms	9 kHz	None
			Average			



MEASUREMENT RESULT: "PHONE_fin QP"

5/14/2011 10:06AM

Frequency MHz	Level dBµV	Transd dB	Limit dBµV	Margin dB	Line	PE
0.154010	55.80	10.1	66	10.0	---	---
0.156010	28.90	10.1	66	36.8	---	---
0.168010	54.90	10.1	65	10.1	---	---
0.532000	40.50	10.1	56	15.5	---	---
0.676000	41.90	10.1	56	14.1	---	---
4.220000	38.90	10.4	56	17.1	---	---
5.000000	36.20	10.5	56	19.8	---	---
5.076000	35.60	10.5	60	24.4	---	---
7.924000	36.60	10.8	60	23.4	---	---

MEASUREMENT RESULT: "PHONE_fin AV"

5/14/2011 10:06AM

Frequency MHz	Level dBμV	Transd dB	Limit dBμV	Margin dB	Line	PE
0.160010	22.10	10.1	56	33.3	---	---
0.164010	35.50	10.1	55	19.7	---	---
0.192010	37.70	10.1	54	16.2	---	---
0.652000	36.20	10.1	46	9.8	---	---
1.184000	32.10	10.2	46	13.9	---	---
4.060000	30.20	10.4	46	15.8	---	---
5.000000	25.90	10.5	46	20.1	---	---
7.812000	25.70	10.8	50	24.3	---	---
9.268000	24.30	10.9	50	25.7	---	---

4.2 Radiated Emission Test

The following table shows the highest levels of Radiated Emissions on both polarization of horizontal and vertical.

Limit Apply to : FCC PART 15 Subpart B Class B

-For measurement below 1 GHz

Detector : Quasi-Peak (6 dB Bandwidth: 120 kHz)

Operation Mode : Data Communication mode

-For measurement above 1 GHz

Setting : Peak mode: Detector- Peak(RBW: 1 MHz / VBW: 1 MHz)
 : Average mode: Detector- Peak (RBW: 1 MHz / VBW: 10 Hz)

Temperature : 23.9 °C

Humidity Level : 47.1 %

Test Date : May 16, 2011

Frequency	Reading	Ant. Factor	Cable Loss	Ant. POL	Total	Limit	Margin
MHz	dB μ V	dB/m	dB	(H/V)	dB μ V/m	dB μ V/m	dB
87.1	13.0	8.6	1.3	H	22.9	40.0	17.1
138.7	11.4	12.2	1.5	V	25.1	43.5	18.4
222.8	16.9	10.6	1.9	H	29.4	46.0	16.6
401.1	18.1	15.4	2.6	H	36.1	46.0	9.9
796.9	3.7	22.4	3.9	V	30.0	46.0	16.0
960.1	5.6	24.0	4.1	H	33.7	54.0	20.3

※ NOTE:

1. Measurement Above 1 GHz performed from 1 GHz to the 5th harmonic of highest fundamental frequency. The highest fundamental frequency is GSM 1 900 center frequency.
2. For measurement above 1 GHz, noise level is more than 14 dB below the limit, specified in FCC Part 15.35.

5. FIELD STRENGTH CALCULATION

The field strength is calculated by adding the antenna factor and cable factor.
 The basic equation with a sample calculation is as follows:

$$FS = RA + AF + CF$$

Where FS = Field Strength

RA = Receiver Amplitude

AF = Antenna Factor

CF = Cable Attenuation Factor

Assume a receiver reading of 21.5 dB μ V is obtained. The antenna factor of 7.4 dB/m and a cable factor of 1.1 dB are added. The 30 dB μ V/m value is mathematically converted to its corresponding level in μ V/m.

$$FS = 21.5 + 7.4 + 1.1 = 30 \text{ dB}\mu\text{V/m}$$

[Radiated Emission Limits]

Frequency of Emission (MHz)	Field Strength	
	μ V/m	dB μ V/m
30 to 88	100	40.0
88 to 216	150	43.5
216 to 960	200	46.0
Above 960	500	54.0

6. TEST EQUIPMENT

<u>Type</u>	<u>Manufacturer</u>	<u>Model Number</u>	<u>Serial Number</u>	<u>Next CAL Date</u>
<u>Conducted Emission</u>				
<input checked="" type="checkbox"/> EMI Test Receiver	Rohde & Schwarz	ESCI	100033	2012.02.15
<input checked="" type="checkbox"/> LISN	Rohde & Schwarz	ESH3-Z5	100282	2012.02.01
<input type="checkbox"/> LISN	Rohde & Schwarz	ENV216	100073	2012.04.01
<input checked="" type="checkbox"/> Attenuator	Rohde & Schwarz	ESH3-Z2	375.8810.352	2011.10.25
<u>Radiated Emission</u>				
<input type="checkbox"/> EMI Test Receiver	Rohde & Schwarz	ESI40	831564103	2011.10.29
<input checked="" type="checkbox"/> EMI Test Receiver	Rohde & Schwarz	ESU26	100241	2011.09.01
<input checked="" type="checkbox"/> Trilog Antenna	Schwarzbeck	VULB9168	255	2011.05.28
<input checked="" type="checkbox"/> Antenna master	INNCO Systems	MA4000-EP	MA4000/283	-
<input checked="" type="checkbox"/> Turn Table	INNCO Systems	DT3000-3T	DT3000/69	-
<input checked="" type="checkbox"/> Communication Antenna	Schwarzbeck	USLP9142	9142-248	-
<input checked="" type="checkbox"/> Power Amplifier	Rohde & Schwarz	SCU-18	10094	2011.09.29
<input type="checkbox"/> Base Station	Rohde & Schwarz	CMU 200	1100000802	2012.02.16
<input checked="" type="checkbox"/> Horn Antenna	Schwarzbeck	BBHA 9120D	-	2012.04.13

7. CONCLUSION

The data collected shows that the **850/1 900 GSM Phone with Bluetooth & WLAN, Model: GT-S5270L, FCC ID: A3LGTS5270L** complies with §15.107 and §15.109 of the FCC rules.