



SAR TEST REPORT

HCT CO., LTD



| | | |
|--|---|---|
| EUT Type: | 850/1900 GSM/GPRS Phone with Bluetooth v3.0 and EDGE Rx only | |
| FCC ID: | A3LGTS3802 | |
| Model: | GT-S3802 | |
| Date of Issue: | Jan. 17, 2013 | |
| Test report No.: | HCTA1301FS03 | |
| Test Laboratory: | HCT CO., LTD. 105-1, Jangam-ri, Majang-myeon, Icheon-si, Gyeonggi-do, Korea 467-811 TEL: +82 31 645 6300 FAX: +82 31 645 6401 | |
| Applicant : | SAMSUNG Electronics Co., Ltd. 129, Samsung-ro, Yeongtong-gu, Suwon-City, Gyeonggi-do, 443-742 Republic of Korea | |
| Testing has been carried out in accordance with: | RSS-102 Issue 4; Health Canada Safety Code 6 47CFR §2.1093 FCC OET Bulletin 65(Edition 97-01), Supplement C (Edition 01-01) ANSI/ IEEE C95.1 – 1992 IEEE 1528-2003 | |
| Test result: | The tested device complies with the requirements in respect of all parameters subject to the test. The test results and statements relate only to the items tested. The test report shall not be reproduced except in full, without written approval of the laboratory. | |
| Signature |  _____ Report prepared by : Young-Soo Jang Test Engineer of SAR Part |  _____ Approved by : Jae-Sang So Manager of SAR Part |

Table of Contents

| | |
|--|-----|
| 1. INTRODUCTION | 3 |
| 2. TEST METHODOLOGY | 4 |
| 3. DESCRIPTION OF DEVICE..... | 5 |
| 4. DESCRIPTION OF TEST EQUIPMENT | 6 |
| 5. SAR MEASUREMENT PROCEDURE..... | 1 3 |
| 6. DESCRIPTION OF TEST POSITION..... | 1 5 |
| 7. MEASUREMENT UNCERTAINTY | 1 7 |
| 8. ANSI/ IEEE C95.1 - 1992 RF EXPOSURE LIMITS | 1 8 |
| 9. SYSTEM VERIFICATION..... | 1 9 |
| 10. RF CONDUCTED POWER MEASUREMENT | 2 0 |
| 11. SAR Test configuration & Antenna Information | 2 2 |
| 12. SAR TEST DATA SUMMARY | 2 3 |
| 12.1 Measurement Results (GSM850 Head SAR)..... | 2 3 |
| 12.2 Measurement Results (GSM1900 Head SAR)..... | 2 4 |
| 12.3 Measurement Results (GSM850 Body-Worn SAR) | 2 5 |
| 12.4 Measurement Results (GSM1900 Body-Worn SAR) | 2 6 |
| 13. SAR Summation Scenario | 2 7 |
| 14. SAR Measurement Variability and Uncertainty | 3 0 |
| 15. CONCLUSION..... | 3 1 |
| 16. REFERENCES | 3 2 |
| Attachment 1. – SAR Test Plots | 3 3 |
| Attachment 2. – Dipole Validation Plots | 5 5 |
| Attachment 3. – Probe Calibration Data | 6 4 |
| Attachment 4. – Dipole Calibration Data | 7 6 |

1. INTRODUCTION

The FCC has adopted the guidelines for evaluating the environmental effects of radio frequency radiation in ET Docket 93-62 on Aug. 6, 1996 to protect the public and workers from the potential hazards of RF emissions due to FCC-regulated portable devices.

The safety limits used for the environmental evaluation measurements are based on the criteria published by the American National Standards Institute (ANSI) for localized specific absorption rate (SAR) in IEEE/ANSI C95.1-1992 Standard for Safety Levels with Respect to Human Exposure to Radio Frequency Electromagnetic Fields, 3 kHz to 300 GHz. 1992 by the Institute of Electrical and Electronics Engineers, Inc., New York, New York 10017. The measurement procedure described in IEEE/ANSI C95.3-1992 Recommended Practice for the Measurement of Potentially Hazardous Electromagnetic Fields - RF and Microwave is used for guidance in measuring SAR due to the RF radiation exposure from the Equipment Under Test (EUT). These criteria for SAR evaluation are similar to those recommended by the National Council on Radiation Protection and Measurements (NCRP) in Biological Effects and Exposure Criteria for Radio frequency Electromagnetic Fields," NCRP Report No. 86 NCRP, 1986, Bethesda, MD 20814. SAR is a measure of the rate of energy absorption due to exposure to an RF transmitting source. SAR values have been related to threshold levels for potential biological hazards.

SAR Definition

Specific Absorption Rate (SAR) is defined as the time derivative of the incremental electromagnetic energy (dW) absorbed by (dissipated in) an incremental mass (dm) contained in a volume element (dV) of a given density (ρ). It is also defined as the rate of RF energy absorption per unit mass at a point in an absorbing body.

$$SAR = \frac{d}{dt} \left(\frac{dU}{dm} \right) = \frac{d}{dt} \left(\frac{dU}{\rho dV} \right)$$

Figure 2. SAR Mathematical Equation

SAR is expressed in units of Watts per Kilogram (W/kg).

where:

$$SAR = \sigma E^2 / \rho$$

| | | |
|----------|---|---|
| σ | = | conductivity of the tissue-simulant material (S/m) |
| ρ | = | mass density of the tissue-simulant material (kg/m ³) |
| E | = | Total RMS electric field strength (V/m) |

NOTE: The primary factors that control rate of energy absorption were found to be the wavelength of the incident field in relations to the dimensions and geometry of the irradiated organism, the orientation of the organism in relation to the polarity of field vectors, the presence of reflecting surfaces, and whether conductive contact is made by the organism with a ground plane.

2. TEST METHODOLOGY

The tests documented in this report were performed in accordance with FCC OET Bulletin 65 Supplement C 01-01, IEEE Standard 1528-2003 & IEEE 1528a-2005 and the following published KDB procedures.

- . 447498 D01 General RF Exposure Guidance v05
- . 450824 D01 SAR Prob Cal and Ver Meas v01r01
- . 450824 D02 Dipole SAR Validation Verification v01
- . 648474 D04 SAR Handsets Multi Xmitter and Ant v01
- . 865664 D01 SAR measurement 100 MHz to 6 GHz v01
- . 865664 D02 SAR Reporting v01
- . 941225 D01 SAR test for 3G devices v02

3. DESCRIPTION OF DEVICE

Environmental evaluation measurements of specific absorption rate (SAR) distributions in emulated human head and body tissues exposed to radio frequency (RF) radiation from wireless portable devices for compliance with the rules and regulations of the U.S. Federal Communications Commission (FCC).

| | | | | | |
|--|---|---------------------|-----------------|------------------------|-----------|
| EUT Type: | 850/1900 GSM/GPRS Phone with Bluetooth v3.0 and EDGE Rx only | | | | |
| FCC ID: | A3LGTS3802 | | | | |
| Model: | GT-S3802 | | | | |
| Trade Name | SAMSUNG Electronics Co., Ltd. | | | | |
| Application Type | Certification | | | | |
| Mode(s) of Operation | GSM850/ GSM1900/ 802.11b/g/n | | | | |
| Tx Frequency | 824.20 - 848.80 MHz (GSM850) 1 850.20 – 1 909.80 MHz (GSM1900) | | | | |
| Rx Frequency | 869.20 - 893.80 MHz (GSM850) 1 930.20 – 1 989.80 MHz (GSM1900) | | | | |
| Production Unit or Identical Prototype | Prototype | | | | |
| Max SAR | Band | Tx Frequency (MHz) | Equipment Class | Reported 1g SAR (W/kg) | |
| | | | | Head | Body-worn |
| | GSM850 | 824.20 - 848.80 | PCE | 0.515 | 0.482 |
| | GSM1900 | 1 850.20 - 1 909.80 | PCE | 1.069 | 0.537 |
| | Bluetooth | 2 402 - 2 480 | DSS | - | |
| Simultaneous SAR per KDB 690783 D01 | | | | 1.329 | 0.667 |
| Date(s) of Tests | Jan. 14, 2013 ~ Jan. 15, 2013 | | | | |
| Antenna Type | Integral Antenna | | | | |
| GPRS | Multislot Class: 12, Mode Class: B | | | | |

4. DESCRIPTION OF TEST EQUIPMENT

4.1 SAR MEASUREMENT SETUP

These measurements are performed using the DASY4 automated dosimetric assessment system. It is made by Schmid & Partner Engineering AG (SPEAG) in Zurich, Switzerland. It consists of high precision robotics system (Staubli), robot controller, Pentium III computer, near-field probe, probe alignment sensor, and the generic twin phantom containing the brain equivalent material. The robot is a six-axis industrial robot performing precise movements to position the probe to the location (points) of maximum electromagnetic field (EMF) (see Figure.3.1).

A cell controller system contains the power supply, robot controller, teach pendant (Joystick), and remote control, is used to drive the robot motors. The PC consists of the HP Pentium IV 3.0 GHz computer with Windows XP system and SAR Measurement Software DASY4, A/D interface card, monitor, mouse, and keyboard. The Staubli Robot is connected to the cell controller to allow software manipulation of the robot. A data acquisition electronic (DAE) circuit performs the signal amplification, signal multiplexing, AD-conversion, offset measurements, mechanical surface detection, collision detection, etc. is connected to the Electro-optical coupler (EOC). The EOC performs the conversion from the optical into digital electric signal of the DAE and transfers data to the PC plug-in card.

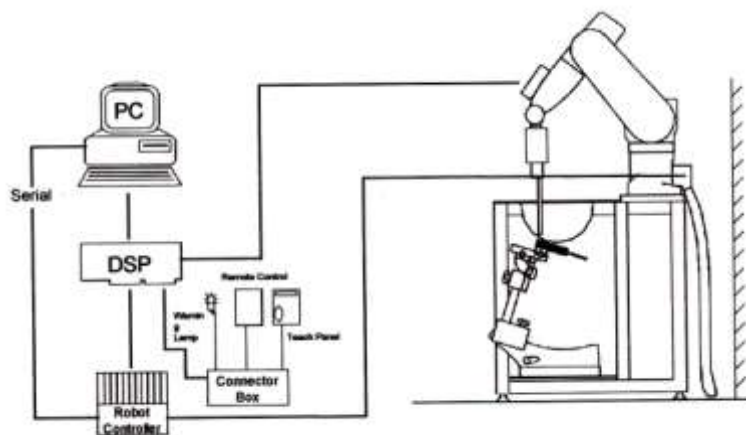

Figure 4.1 HCT SAR Lab. Test Measurement Set-up

The DAE4 consists of a highly sensitive electrometer-grade preamplifier with auto-zeroing, a channel and gain-switching multiplexer, a fast 16 bit AD-converter and a command decoder and control logic unit. Transmission to the PC-card is accomplished through an optical downlink for data and status information and an optical uplink for commands and clock lines. The mechanical probe mounting device includes two different sensor systems for frontal and sidewise probe contacts. They are also used for mechanical surface detection and probe collision detection. The robot uses its own controller with a built in VME-bus computer. The system is described in detail in.

4.2 DASY E-FIELD PROBE SYSTEM

4.2.1 ET3DV6 Probe Specification

| | |
|-------------------|--|
| Construction | Symmetrical design with triangular core Built-in optical fiber for surface detection System Built-in shielding against static charges |
| Calibration | In air from 10 MHz to 2.5 GHz In brain and muscle simulating tissue at Frequencies of 450 MHz, 900 MHz and 1.8 GHz (accuracy: 8 %) |
| Frequency | 10 MHz to > 3 GHz; Linearity: ± 0.2 dB (30 MHz to 3 GHz) |
| Directivity | ± 0.2 dB in brain tissue (rotation around probe axis) ± 0.4 dB in brain tissue (rotation normal probe axis) |
| Dynamic | 5 μ W/g to > 100 mW/g; |
| Range Linearity: | ± 0.2 dB |
| Surface Detection | ± 0.2 mm repeatability in air and clear liquids over diffuse reflecting surfaces. |
| Dimensions | Overall length: 337 mm Tip length: 16 mm Body diameter: 12 mm Tip diameter: 6.8 mm Distance from probe tip to dipole centers: 2.7 mm |
| Application | General dissymmetry up to 3 GHz Compliance tests of mobile phones Fast automatic scanning in arbitrary phantoms |



Figure 4.2 Photograph of the probe and the Phantom

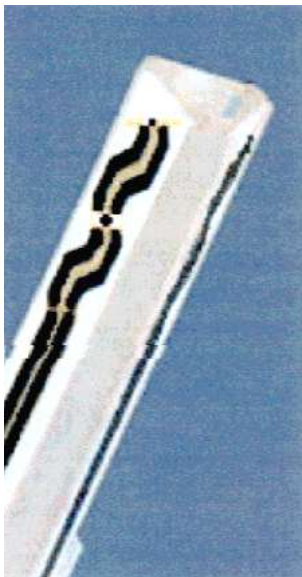

Figure 4.3 ET3DV6 E-field Probe

The SAR measurements were conducted with the dosimetric probe ET3DV6, designed in the classical triangular configuration and optimized for dosimetric evaluation. The probe is constructed using the thick film technique; with printed resistive lines on ceramic substrates. The probe is equipped with an optical multifiber line ending at the front of the probe tip. It is connected to the EOC box on the robot arm and provides an automatic detection of the phantom surface. Half of the fibers are connected to a pulsed infrared transmitter, the other half to a synchronized receiver. As the probe approaches the surface, the reflection from the surface produces a coupling from the transmitting to the receiving fibers. This reflection increases first during the approach, reaches a maximum and then decreases. If the probe is flatly touching the surface, the coupling is zero. The distance of the coupling maximum to the surface is independent of the surface reflectivity and largely independent of the surface to probe angle. The DASY4 software reads the reflection during a software approach and looks for the maximum using a 2nd order fitting. The approach is stopped at reaching the maximum.

4.3 PROBE CALIBRATION PROCESS

4.3.1 E-Probe Calibration

Each probe is calibrated according to a dosimetric assessment procedure with an accuracy better than ± 10 %. The spherical isotropy was evaluated with the proper procedure and found to be better than ± 0.25 dB. The sensitivity parameters (NormX, NormY, NormZ), the diode compression parameter (DCP) and the conversion factor (ConvF) of the probe is tested.

The free space E-field from amplified probe outputs is determined in a test chamber. This is performed in a TEM cell for frequencies below 1 GHz, and in a waveguide above 1 GHz for free space. For the free space calibration, the probe is placed in the volumetric center of the cavity and at the proper orientation with the field. The probe is then rotated 360 degrees.

E-field temperature correlation calibration is performed in a flat phantom filled with the appropriate simulated brain tissue. The measured free space E-field in the medium correlates to temperature rise in a dielectric medium. For temperature correlation calibration a RF transparent thermistor-based temperature probe is used in conjunction with the E-field probe.

$$SAR = C \frac{\Delta T}{\Delta t}$$

where:

- Δt = exposure time (30 seconds),
- C = heat capacity of tissue (brain or muscle),
- ΔT = temperature increase due to RF exposure.

SAR is proportional to $\Delta T / \Delta t$, the initial rate of tissue heating, before thermal diffusion takes place. Now it's possible to quantify the electric field in the simulated tissue by equating the thermally derived SAR to the E- field;

$$SAR = \frac{|E|^2 \cdot \sigma}{\rho}$$

where:

- σ = simulated tissue conductivity,
- ρ = Tissue density (1.25 g/cm³ for brain tissue)

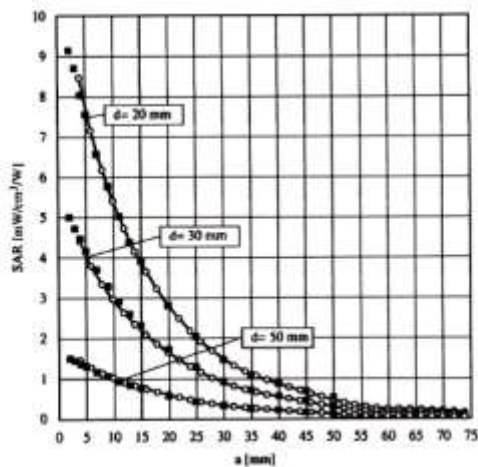

Figure 4.4 E-Field and Temperature measurements at 900 MHz

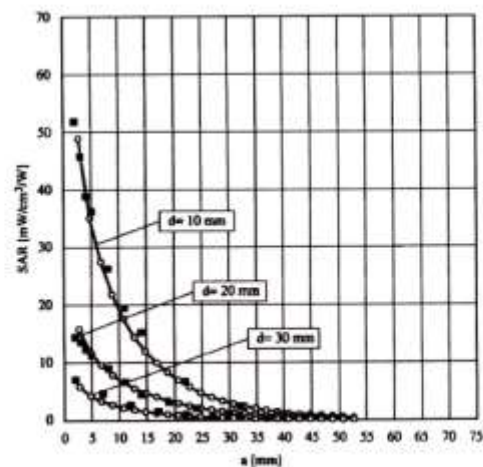

Figure 4.5 E-Field and temperature measurements at 1.8 GHz

4.3.2 Data Extrapolation

The DASY4 software automatically executes the following procedures to calculate the field units from the microvolt readings at the probe connector. The first step of the evaluation is a linearization of the filtered input signal to account for the compression characteristics of the detector diode. The compensation depends on the input signal, the diode type and the DC-transmission factor from the diode to the evaluation electronics. If the exciting field is pulsed, the crest factor of the signal must be known to correctly compensate for peak power. The formula for each channel can be given like below;

$$V_i = U_i + U_i^2 \cdot \frac{cf}{dcp_i}$$

with V_i = compensated signal of channel i (i=x,y,z)
 U_i = input signal of channel i (i=x,y,z)
 cf = crest factor of exciting field (DASY parameter)
 dcp_i = diode compression point (DASY parameter)

From the compensated input signals the primary field data for each channel can be evaluated:

E-field probes:

$$E_i = \sqrt{\frac{V_i}{Norm_i \cdot ConvF}}$$

with V_i = compensated signal of channel i (i = x,y,z)
 $Norm_i$ = sensor sensitivity of channel i (i = x,y,z)
 $\mu V/(V/m)^2$ for E-field probes
 $ConvF$ = sensitivity of enhancement in solution
 E_i = electric field strength of channel i in V/m

The RSS value of the field components gives the total field strength (Hermetian magnitude):

$$E_{tot} = \sqrt{E_x^2 + E_y^2 + E_z^2}$$

The primary field data are used to calculate the derived field units.

$$SAR = E_{tot}^2 \cdot \frac{\sigma}{\rho \cdot 1000}$$

with SAR = local specific absorption rate in W/g
 E_{tot} = total field strength in V/m
 σ = conductivity in [mho/m] or [Siemens/m]
 ρ = equivalent tissue density in g/cm³

The power flow density is calculated assuming the excitation field to be a free space field.

$$P_{pwr} = \frac{E_{tot}^2}{3770}$$

with P_{pwr} = equivalent power density of a plane wave in W/cm²
 E_{tot} = total electric field strength in V/m

4.4 SAM Phantom

The shell corresponds to the specifications of the Specific Anthropomorphic Mannequin (SAM) phantom defined in IEEE 1528 and IEC 62209-1. It enables the dosimetric evaluation of left and right hand phone usage as well as body mounted usage at the flat phantom region. A cover prevents evaporation of the liquid. Reference markings on the phantom allow the complete setup of all predefined phantom positions and measurement grids by teaching three points with the robot.



Figure 3.6 SAM Phantom

| | |
|-----------------|---|
| Shell Thickness | 2.0 mm ± 0.2 mm (6 ± 0.2 mm at ear point) |
| Filling Volume | about 25 L |
| Dimensions | 810 mm x 1 000 mm x 500 mm (H x L x W) |

Triple Modular Phantom consists of three identical modules which can be installed and removed separately without emptying the liquid. It includes three reference points for phantom installation. Covers prevent evaporation of the liquid. Phantom material is resistant to DGBE based tissue simulating liquids. The MFP V5.1 will be delivered including wooden support only (**non**-standard SPEAG support).

Applicable for system performance check from 700 MHz to 6 GHz (MFP V5.1C) or 800 MHz - 6 GHz (MFP V5.1A) as well as dosimetric evaluations for body-worn operation.

| | |
|-----------------|-------------------------|
| Shell Thickness | 2.0 mm ± 0.2 mm |
| Filling Volume | approx. 9.2 L |
| Dimensions | 830 mm x 500 mm (L x W) |



Figure 4.6 MFP V5.1 Triple Modular Phantom

4.5 Device Holder for Transmitters

In combination with the SAM Phantom V 4.0, the Mounting Device (POM) enables the rotation of the mounted transmitter in spherical coordinates whereby the rotation points is the ear opening. The devices can be easily, accurately, and repeatably positioned according to the FCC and CENELEC specifications. The device holder can be locked at different phantom locations (left head, right head, flat phantom).

Note: A simulating human hand is not used due to the complex anatomical and geometrical structure of the hand that may produce infinite number of configurations. To produce the Worst-case condition (the hand absorbs antenna output power), the hand is omitted during the tests.



Figure 4.7 Device Holder

4.6 Brain & Muscle Simulating Mixture Characterization

The brain and muscle mixtures consist of a viscous gel using hydrox-ethyl cellulose (HEC) gelling agent and saline solution (see Table 3.1). Preservation with a bactericide is added and visual inspection is made to make sure air bubbles are not trapped during the mixing process. The mixture is calibrated to obtain proper dielectric constant (permittivity) and conductivity of the desired tissue. The mixture characterizations used for the brain and muscle tissue simulating liquids are according to the data by C. Gabriel and G. Hartsgrove.

| Ingredients (% by weight) | Frequency (MHz) | | | | | | | | | | | |
|------------------------------|-----------------|-------|------|------|-------|------|-------|-------|-------|------|-------|------|
| | 450 | | 750 | | 835 | | 915 | | 1 900 | | 2 450 | |
| Tissue Type | Head | Body | Head | Body | Head | Body | Head | Body | Head | Body | Head | Body |
| Water | 38.56 | 51.16 | 41.2 | 51.7 | 41.45 | 52.4 | 41.05 | 56.0 | 54.9 | 40.4 | 62.7 | 73.2 |
| Salt (NaCl) | 3.95 | 1.49 | 1.4 | 1.0 | 1.45 | 1.4 | 1.35 | 0.76 | 0.18 | 0.5 | 0.5 | 0.04 |
| Sugar | 56.32 | 46.78 | 57 | 47.2 | 56.0 | 45.0 | 56.5 | 41.76 | 0.0 | 58.0 | 0.0 | 0.0 |
| HEC | 0.98 | 0.52 | 0.2 | 0.0 | 1.0 | 1.0 | 1.0 | 1.21 | 0.0 | 1.0 | 0.0 | 0.0 |
| Bactericide | 0.19 | 0.05 | 0.2 | 0.1 | 0.1 | 0.1 | 0.1 | 0.27 | 0.0 | 0.1 | 0.0 | 0.0 |
| Triton X-100 | 0.0 | 0.0 | 0.00 | 0.0 | 0.0 | 0.0 | 0.0 | 0.0 | 0.0 | 0.0 | 36.8 | 0.0 |
| DGBE | 0.0 | 0.0 | 0.00 | 0.0 | 0.0 | 0.0 | 0.0 | 0.0 | 44.92 | 0.0 | 0.0 | 26.7 |

Salt: 99 % Pure Sodium Chloride Sugar: 98 % Pure Sucrose
 Water: De-ionized, 16M resistivity HEC: Hydroxyethyl Cellulose
 DGBE: 99 % Di(ethylene glycol) butyl ether,[2-(2-butoxyethoxy) ethanol]
 Triton X-100(ultra pure): Polyethylene glycol mono[4-(1,1,3,3-tetramethylbutyl)phenyl] ether

Table 3.1 Composition of the Tissue Equivalent Matter

4.7 SAR TEST EQUIPMENT

| Manufacturer | Type / Model | S/N | Calib. Date | Calib.Interval | Calib.Due |
|--------------|-------------------------------|-----------------|---------------|----------------|---------------|
| SPEAG | SAM Phantom | - | N/A | N/A | N/A |
| Staubli | Robot RX90L | F01/5K09A1/A/01 | N/A | N/A | N/A |
| Staubli | Robot ControllerCS7MB | F99/5A82A1/C/01 | N/A | N/A | N/A |
| HP | Pavilion t000_puffer | KRJ51201TV | N/A | N/A | N/A |
| SPEAG | Light Alignment Sensor | 265 | N/A | N/A | N/A |
| Staubli | Teach Pendant (Joystick) | D221340.01 | N/A | N/A | N/A |
| SPEAG | DAE4 | 869 | Sep 18, 2012 | Annual | Sep 18, 2013 |
| SPEAG | E-Field Probe ET3DV6 | 1605 | Apr. 26, 2012 | Annual | Apr. 26, 2013 |
| SPEAG | Validation Dipole D835V2 | 441 | May 16, 2012 | Annual | May 16, 2013 |
| SPEAG | Validation Dipole D1900V2 | 5d032 | July 20, 2012 | Annual | July 20, 2013 |
| Agilent | Power Meter(F) E4419B | MY41291386 | Nov. 04, 2011 | Annual | Nov. 02, 2013 |
| Agilent | Power Sensor(G) 8481 | MY41090870 | Nov. 04, 2011 | Annual | Nov. 02, 2013 |
| HP | Dielectric Probe Kit 85070C | 00721521 | N/A | N/A | N/A |
| HP | Dual Directional Coupler 778D | 16072 | Nov. 02, 2012 | Annual | Nov. 02, 2013 |
| Agilent | Base Station CMU200 | 110740 | July 23, 2012 | Annual | July 23, 2013 |
| HP | Base Station E5515C | GB44400269 | Feb. 10, 2012 | Annual | Feb. 10, 2013 |
| HP | Signal Generator 8664A | 3744A02069 | Nov. 02, 2012 | Annual | Nov. 02, 2013 |
| TESCOM | TC-3000C / BLUETOOTH | 3000C000276 | Jul. 11, 2012 | Annual | Jul. 11, 2013 |

NOTE:

The E-field probe was calibrated by SPEAG, by the waveguide technique procedure. Dipole Validation measurement is performed by HCT Lab. before each test. The brain simulating material is calibrated by HCT using the dielectric probe system and network analyzer to determine the conductivity and permittivity (dielectric constant) of the brain-equivalent material.

5. SAR MEASUREMENT PROCEDURE

The evaluation was performed with the following procedure:

1. The SAR value at a fixed location above the ear point was measured and was used as a reference value for assessing the power drop.
2. The SAR distribution at the exposed side of the head was measured at a distance of 3.9 mm from the inner surface of the shell. The area covered the entire dimension of the head and the horizontal grid spacing was 15 mm x 15 mm. Based on this data, the area of the maximum absorption was determined by spline interpolation.
3. Around this point, a volume of 32 mm x 32 mm x 30 mm was assessed by measuring 5 x 5 x 7 points. On this basis of this data set, the spatial peak SAR value was evaluated with the following procedure:
 - a. The data at the surface were extrapolated, since the center of the dipoles is 2.7 mm away from the tip of the probe and the distance between the surface and the lowest measuring point is 1.2 mm. The extrapolation was based on a least square algorithm. A polynomial of the fourth order was calculated through the points in z-axis. This polynomial was then used to evaluate the points between the surface and the probe tip.
 - b. The maximum interpolated value was searched with a straight-forward algorithm. Around this maximum the SAR values averaged over the spatial volumes (1 g or 10 g) were computed using the 3D-Spline interpolation algorithm. The 3D-spline is composed of three one-dimensional splines with the "Not a knot" condition (in x, y, and z directions. The volume was integrated with the trapezoidal algorithm. One thousand points (10 x 10 x 10) were interpolated to calculate the average.
 - c. All neighboring volumes were evaluated until no neighboring volume with a higher average value was found.
4. The SAR value, at the same location as procedure #1, was re-measured. If the value changed by more than 5 %, the evaluation is repeated.

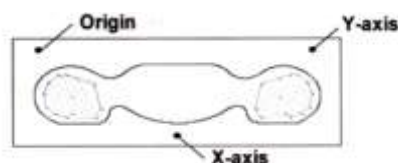

Figure 5.1 SAR Measurement Point in Area Scan

First Area Scan is used to locate the approximate location(s) of the local peak SAR value(s). The measurement grid within an Area Scan is defined by the grid extend, grid step size and grid offset. Next, in order to determine the EM field distribution in a three-dimensional spatial extension, Zoom Scan is required. The Zoom Scan is performed around the highest E-field value to determine the averaged SASR-distribution over 10g.

Area scan and zoom scan resolution setting follow KDB 865664 D01v01 quoted below

| | | ≤ 3 GHz | > 3 GHz |
|--|------------------------------------|--|---|
| Maximum distance from closest measurement point (geometric center of probe sensors) to phantom surface | | 5 ± 1 mm | $\frac{1}{2} \cdot \delta \cdot \ln(2) \pm 0.5$ mm |
| Maximum probe angle from probe axis to phantom surface normal at the measurement location | | $30^\circ \pm 1^\circ$ | $20^\circ \pm 1^\circ$ |
| Maximum area scan spatial resolution: $\Delta x_{Area}, \Delta y_{Area}$ | | ≤ 2 GHz: ≤ 15 mm 2 – 3 GHz: ≤ 12 mm | 3 – 4 GHz: ≤ 12 mm 4 – 6 GHz: ≤ 10 mm |
| | | When the x or y dimension of the test device, in the measurement plane orientation, is smaller than the above, the measurement resolution must be \leq the corresponding x or y dimension of the test device with at least one measurement point on the test device. | |
| Maximum zoom scan spatial resolution: $\Delta x_{Zoom}, \Delta y_{Zoom}$ | | ≤ 2 GHz: ≤ 8 mm 2 – 3 GHz: ≤ 5 mm* | 3 – 4 GHz: ≤ 5 mm* 4 – 6 GHz: ≤ 4 mm* |
| Maximum zoom scan spatial resolution, normal to phantom surface | uniform grid: $\Delta z_{Zoom}(n)$ | ≤ 5 mm | 3 – 4 GHz: ≤ 4 mm 4 – 5 GHz: ≤ 3 mm 5 – 6 GHz: ≤ 2 mm |
| | graded grid | $\Delta z_{Zoom}(1)$: between 1 st two points closest to phantom surface | ≤ 4 mm |
| | | $\Delta z_{Zoom}(n>1)$: between subsequent points | $\leq 1.5 \cdot \Delta z_{Zoom}(n-1)$ |
| Minimum zoom scan volume | x, y, z | ≥ 30 mm | 3 – 4 GHz: ≥ 28 mm 4 – 5 GHz: ≥ 25 mm 5 – 6 GHz: ≥ 22 mm |
| Note: δ is the penetration depth of a plane-wave at normal incidence to the tissue medium; see draft standard IEEE P1528-2011 for details. * When zoom scan is required and the <i>reported</i> SAR from the area scan based <i>1-g SAR estimation</i> procedures of KDB 447498 is ≤ 1.4 W/kg, ≤ 8 mm, ≤ 7 mm and ≤ 5 mm zoom scan resolution may be applied, respectively, for 2 GHz to 3 GHz, 3 GHz to 4 GHz and 4 GHz to 6 GHz. | | | |

6. DESCRIPTION OF TEST POSITION

6.1 HEAD POSITION

The device was placed in a normal operating position with the Point A on the device, as illustrated in following drawing, aligned with the location of the RE(ERP) on the phantom. With the ear-piece pressed against the head, the vertical center line of the body of the handset was aligned with an imaginary plane consisting of the RE, LE and M. While maintaining these alignments, the body of the handset was gradually moved towards the cheek until any point on the mouth-piece or keypad contacted the cheek. This is a cheek/touch position. For ear/tilt position, while maintain the device aligned with the BM and FN lines, the device was pivot against ERP back for 15° or until the device antenna touch the phantom. Please refer to IEEE 1528-2003 illustration below.

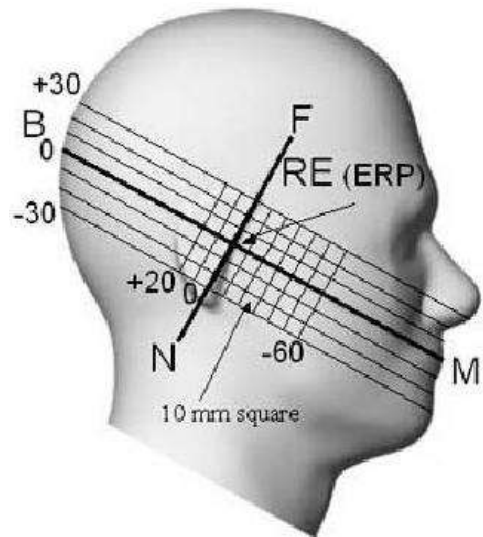

Figure 6.1 Side view of the phantom

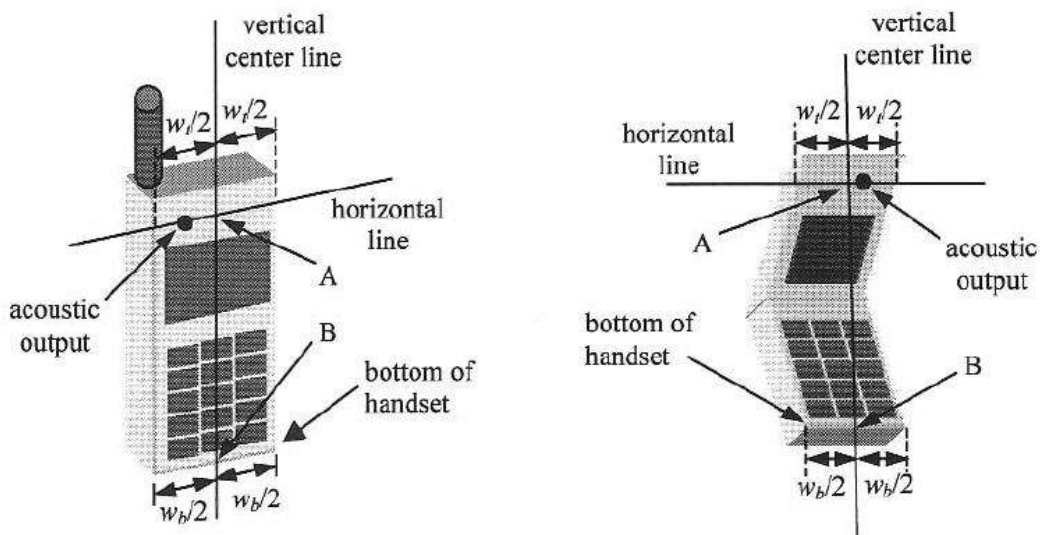

Figure 6.2 Handset vertical and horizontal reference lines

6.2 Body Holster/Belt Clip Configurations

Body-worn operating configurations are tested with the belt-clips and holsters attached to the device and positioned against a flat phantom in a normal use configuration. A device with a headset output is tested with a headset connected to the device. Body dielectric parameters are used.

Accessories for Body-worn operation configurations are divided into two categories: those that do not contain metallic components and those that contain metallic components. When multiple accessories that do not contain metallic components are supplied with the device, the device is tested with only the accessory that dictates the closest spacing to the body. Then multiple accessories that contain metallic components are tested with each accessory. If multiple accessory share an identical metallic component (i.e. the same metallic belt-clip used with different holsters with no other metallic components) only the accessory that dictates the closest spacing to the body is tested.

Body-worn accessories may not always be supplied or available as options for some Devices intended to be authorized for body-worn use. In this case, a test configuration with a separation distance between the back of the device and the flat phantom is used.

Since this EUT does not supply any body worn accessory to the end user a distance of 1.5 cm from the EUT back surface to the liquid interface is configured for the generic test.

"See the Test SET-UP Photo"

Transmitters that are designed to operate in front of a person's face, as in push-to-talk configurations, are tested for SAR compliance with the front of the device positioned to face the flat phantom. For devices that are carried next to the body such as a shoulder, waist or chest-worn transmitters, SAR compliance is tested with the accessory(ies), including headsets and microphones, attached to the device and positioned against a flat phantom in a normal use configuration.

In all cases SAR measurements are performed to investigate the worst-case positioning. Worstcase positioning is then documented and used to perform Body SAR testing.

7. MEASUREMENT UNCERTAINTY

| Error Description | Tol (± %) | Prob. dist. | Div. | c_i | Standard Uncertainty (± %) | v_{eff} |
|-------------------------------------|--------------|----------------|------|-------|----------------------------------|-----------|
| 1. Measurement System | | | | | | |
| Probe Calibration | 6.00 | N | 1 | 1 | 6.00 | ∞ |
| Axial Isotropy | 4.70 | R | 1.73 | 0.7 | 1.90 | ∞ |
| Hemispherical Isotropy | 9.60 | R | 1.73 | 0.7 | 3.88 | ∞ |
| Boundary Effects | 1.00 | R | 1.73 | 1 | 0.58 | ∞ |
| Linearity | 4.70 | R | 1.73 | 1 | 2.71 | ∞ |
| System Detection Limits | 1.00 | R | 1.73 | 1 | 0.58 | ∞ |
| Readout Electronics | 0.30 | N | 1.00 | 1 | 0.30 | ∞ |
| Response Time | 0.8 | R | 1.73 | 1 | 0.46 | ∞ |
| Integration Time | 2.6 | R | 1.73 | 1 | 1.50 | ∞ |
| RF Ambient Conditions | 3.00 | R | 1.73 | 1 | 1.73 | ∞ |
| Probe Positioner | 0.40 | R | 1.73 | 1 | 0.23 | ∞ |
| Probe Positioning | 2.90 | R | 1.73 | 1 | 1.67 | ∞ |
| Max SAR Eval | 1.00 | R | 1.73 | 1 | 0.58 | ∞ |
| 2. Test Sample Related | | | | | | |
| Device Positioning | 2.90 | N | 1.00 | 1 | 2.90 | 145 |
| Device Holder | 3.60 | N | 1.00 | 1 | 3.60 | 5 |
| Power Drift | 5.00 | R | 1.73 | 1 | 2.89 | ∞ |
| 3. Phantom and Setup | | | | | | |
| Phantom Uncertainty | 4.00 | R | 1.73 | 1 | 2.31 | ∞ |
| Liquid Conductivity(target) | 5.00 | R | 1.73 | 0.64 | 1.85 | ∞ |
| Liquid Conductivity(meas.) | 2.07 | N | 1 | 0.64 | 1.32 | 9 |
| Liquid Permittivity(target) | 5.00 | R | 1.73 | 0.6 | 1.73 | ∞ |
| Liquid Permittivity(meas.) | 5.02 | N | 1 | 0.6 | 3.01 | 9 |
| Combine Standard Uncertainty | | | | | 11.13 | |
| Coverage Factor for 95 % | | | | | $k=2$ | |
| Expanded STD Uncertainty | | | | | 22.25 | |

Table 7.1 Uncertainty (800 MHz- 2450 MHz)

8. ANSI/ IEEE C95.1 - 1992 RF EXPOSURE LIMITS

| HUMAN EXPOSURE | UNCONTROLLED ENVIRONMENT General Population (W/kg) or (mW/g) | CONTROLLED ENVIRONMENT Occupational (W/kg) or (mW/g) |
|--|--|--|
| SPATIAL PEAK SAR * (Brain) | 1.60 | 8.00 |
| SPATIAL AVERAGE SAR ** (Whole Body) | 0.08 | 0.40 |
| SPATIAL PEAK SAR *** (Hands / Feet / Ankle / Wrist) | 4.00 | 20.00 |

Table 8.1 Safety Limits for Partial Body Exposure

NOTES:

* The Spatial Peak value of the SAR averaged over any 1 g of tissue (defined as a tissue volume in the shape of a cube) and over the appropriate averaging time.

** The Spatial Average value of the SAR averaged over the whole-body.

*** The Spatial Peak value of the SAR averaged over any 10 g of tissue (defined as a tissue volume in the shape of a cube) and over the appropriate averaging time.

Uncontrolled Environments are defined as locations where there is the exposure of individuals who have no knowledge or control of their exposure.

Controlled Environments are defined as locations where there is exposure that may be incurred by persons who are aware of the potential for exposure, (i.e.as a result of employment or occupation).

9. SYSTEM VERIFICATION

9.1 Tissue Verification

| Freq. [MHz] | Date | Liquid | Liquid Temp. [°C] | Parameters | Target Value | Measured Value | Deviation [%] | Limit [%] |
|-------------|---------------|--------------|-------------------|--------------|--------------|----------------|---------------|-----------|
| 835 | Jan. 14, 2013 | Head | 21.3 | ϵ_r | 41.5 | 40.4 | - 2.65 | ± 5 |
| | | | | σ | 0.90 | 0.918 | + 2.00 | ± 5 |
| Body | | ϵ_r | | 55.2 | 57.1 | + 3.44 | ± 5 | |
| | | σ | | 0.97 | 0.984 | + 1.44 | ± 5 | |
| 1 900 | Jan. 15, 2013 | Head | 21.2 | ϵ_r | 40.0 | 40.9 | + 2.25 | ± 5 |
| | | | | σ | 1.40 | 1.37 | - 2.14 | ± 5 |
| Body | | ϵ_r | | 53.3 | 52 | - 2.44 | ± 5 | |
| | | σ | | 1.52 | 1.55 | + 1.97 | ± 5 | |

The Tissue dielectronic parameters were measured prior to the SAR evaluation using an Agilent 85070C Dielectronic Probe Kit and Agilent Network Analyzer.

9.2 System Validation

Prior to assessment, the system is verified to the $\pm 10\%$ of the specifications at 835 MHz / 1 900 MHz by using the system validation kit. (Graphic Plots Attached)

| Freq. [MHz] | Date | Probe (SN) | Liquid | Amb. Temp. [°C] | Liquid Temp. [°C] | 1 W Target SAR _{1g} (SPEAG) (mW/g) | Measured SAR _{1g} (mW/g) | 1 W Normalized SAR _{1g} (mW/g) | Deviation [%] | Limit [%] |
|-------------|---------------|------------|--------|-----------------|-------------------|---|-----------------------------------|---|---------------|-----------|
| 835 | Jan. 14, 2013 | 1605 | Head | 21.5 | 21.3 | 9.43 | 0.961 | 9.61 | + 1.91 | ± 10 |
| 835 | | | Body | | | 9.50 | 0.957 | 9.57 | + 0.74 | ± 10 |
| 1 900 | Jan. 15, 2013 | | Head | 21.4 | 21.2 | 39.0 | 3.85 | 38.5 | - 1.28 | ± 10 |
| 1 900 | | | Body | | | 39.9 | 3.89 | 38.9 | - 2.51 | ± 10 |

9.3 System Validation Procedure

SAR measurement was prior to assessment, the system is verified to the $\pm 10\%$ of the specifications at each frequency band by using the system validation kit. (Graphic Plots Attached)

- Cabling the system, using the validation kit equipments.
- Generate about 100 mW Input Level from the Signal generator to the Dipole Antenna.
- Dipole Antenna was placed below the Flat phantom.
- The measured one-gram SAR at the surface of the phantom above the dipole feed-point should be within 10 % of the target reference value.
- The results are normalized to 1 W input power.

Note;

SAR Verification was performed according to the FCC KDB 450824.

10. RF CONDUCTED POWER MEASUREMENT

Power measurements were performed using a base station simulator under digital average power. The handset was placed into a simulated call using a base station simulator in a shielded chamber. Such test signals offer a consistent means for testing SAR and are recommended for evaluation SAR. SAR measurements were taken with a fully charged battery. In order to verify that the device was tested and maintained at full power, this was configured with the base station simulator. The SAR measurement Software calculates a reference point at the start and end of the test to check for power drifts. If conducted Power deviations of more than 5 % occurred, the tests were repeated.

10.1 GSM

Conducted output power measurements were performed using a base station simulator under digital average power.



SAR Test for WWAN were performed with a base station simulator Agilent E5515C. Communication between the device and the emulator was established by air link. Set base station emulator to allow DUT to radiate maximum output power during all tests. Please refer to the below worst case SAR operation setup.

- GSM voice: Head SAR
- GPRS Multi-slots : GPRS850/1900 Body SAR with GPRS Multi-slot Class12, 4Tx with CS 1 (GMSK)

Note;

CS1/MCS7 coding scheme was used in GPRS/EDGE output power measurements and SAR Testing, as a condition where GMSK/8PSK modulation was ensured. Investigation has shown that CS1 - CS4/ MCS5 – MCS9 settings do not have any impact on the output levels in the GPRS/EDGE modes.

GSM850

Target Power : 32.5 dBm

Tune-up Tolerance : -1.5 dB/ +0.5 dB

GSM1900

Target Power : 29.0 dBm

Tune-up Tolerance : -1.5 dB/ +0.5 dB

GSM Conducted output powers (Burst-Average)

| Band | Channel | GSM | GPRS(GMSK) Data – CS1 | | | |
|----------|---------|-------------|-----------------------|----------------------|----------------------|----------------------|
| | | Voice (dBm) | GPRS 1 TX Slot (dBm) | GPRS 2 TX Slot (dBm) | GPRS 3 TX Slot (dBm) | GPRS 4 TX Slot (dBm) |
| GSM 850 | 128 | 32.73 | 32.74 | 30.70 | 29.67 | 28.66 |
| | 190 | 32.73 | 32.73 | 30.75 | 29.72 | 28.72 |
| | 251 | 32.71 | 32.71 | 30.71 | 29.69 | 28.69 |
| GSM 1900 | 512 | 29.09 | 29.18 | 27.30 | 26.23 | 25.23 |
| | 661 | 29.12 | 29.16 | 27.17 | 26.13 | 25.12 |
| | 810 | 28.81 | 28.84 | 26.85 | 25.79 | 24.78 |

GSM Conducted output powers (Frame-Average)

| Band | Channel | GSM | GPRS Data | | | |
|----------|---------|-------------|----------------------|----------------------|----------------------|----------------------|
| | | Voice (dBm) | GPRS 1 TX Slot (dBm) | GPRS 2 TX Slot (dBm) | GPRS 3 TX Slot (dBm) | GPRS 4 TX Slot (dBm) |
| GSM 850 | 128 | 23.7 | 23.71 | 24.68 | 25.41 | 25.65 |
| | 190 | 23.7 | 23.7 | 24.73 | 25.46 | 25.71 |
| | 251 | 23.68 | 23.68 | 24.69 | 25.43 | 25.68 |
| GSM 1900 | 512 | 20.06 | 20.15 | 21.28 | 21.97 | 22.22 |
| | 661 | 20.09 | 20.13 | 21.15 | 21.87 | 22.11 |
| | 810 | 19.78 | 19.81 | 20.83 | 21.53 | 21.77 |

Note:

Time slot average factor is as follows:

1 Tx slot = 9.03 dB, Frame-Average output power = Burst-Average output power – 9.03 dB

2 Tx slot = 6.02 dB, Frame-Average output power = Burst-Average output power – 6.02 dB

3 Tx slot = 4.26 dB, Frame-Average output power = Burst-Average output power – 4.26 dB

4 Tx slot = 3.01 dB, Frame-Average output power = Burst-Average output power – 3.01 dB

11. SAR Test configuration & Antenna Information

11.1 Antenna and Device Information

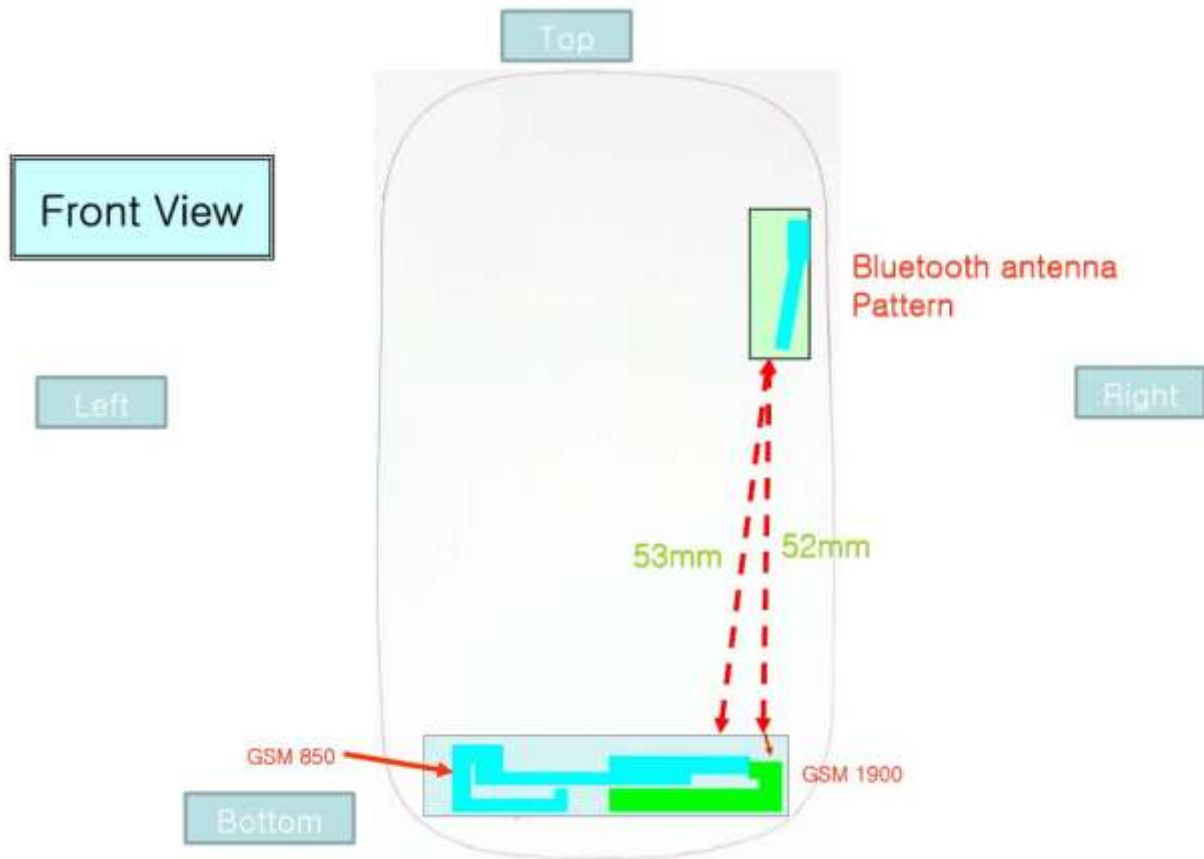

[Front side View]

Note;

Please see the separate Antenna distance document.

12. SAR TEST DATA SUMMARY

12.1 Measurement Results (GSM850 Head SAR)

| Frequency | | Modulation | Conducted Power (dBm) | Power Drift (dB) | Battery | Phantom Position | Measured SAR(mW/g) | Scaled SAR(mW/g) | Plot No |
|---|-----------|------------|-----------------------|------------------|----------|--|--------------------|------------------|---------|
| MHz | Channel | | | | | | | | |
| 836.6 | 190 (Mid) | GSM850 | 32.73 | -0.032 | Standard | Left Ear | 0.484 | 0.515 | 1 |
| | | | 32.73 | -0.110 | Standard | Left Tilt 15° | 0.123 | 0.131 | 2 |
| | | | 32.73 | -0.161 | Standard | Right Ear | 0.420 | 0.447 | 3 |
| | | | 32.73 | 0.06 | Standard | Right Tilt 15° | 0.135 | 0.144 | 4 |
| ANSI/ IEEE C95.1 - 1992– Safety Limit Spatial Peak Uncontrolled Exposure/ General Population | | | | | | Head 1.6 W/kg (mW/g) Averaged over 1 gram | | | |

NOTES:

- 1 The test data reported are the worst-case SAR value with the antenna-head position set in a typical configuration. Test procedures used are according to FCC/OET Bulletin 65, Supplement C [July 2001].
- 2 All modes of operation were investigated and the worst-case are reported.
- 3 Measured Depth of Simulating Tissue is 15.0 cm ± 0.2 cm.
- 4 Tissue parameters and temperatures are listed on the SAR plot.
- 5 Battery Type Standard Extended Slim
Batteries are fully charged for all readings.
- 6 Test Signal Call Mode Manual Test cord Base Station Simulator
- 7 According to KDB 447498, Testing of other required channels within the operating mode of a frequency band is not required when the reported 1-g or 10-g SAR for the mid-band or highest output power channel is ≤ 0.8 W/kg or 2.0 W/kg, for 1-g or 10-g respectively, when the transmission band is ≤ 100 MHz.

12.2 Measurement Results (GSM1900 Head SAR)

| Frequency | | Modulation | Conducted Power (dBm) | Power Drift (dB) | Battery | Phantom Position | Measured SAR(mW/g) | Scaled SAR(mW/g) | Plot No. |
|---|------------|------------|-----------------------|------------------|----------|--|--------------------|------------------|----------|
| MHz | Channel | | | | | | | | |
| 1850.2 | 512 (low) | GSM1900 | 29.09 | -0.042 | Standard | Left Ear | 0.918 | 1.009 | 5 |
| 1 880.0 | 661 (Mid) | GSM1900 | 29.12 | -0.062 | Standard | Left Ear | 0.962 | 1.050 | 6 |
| 1909.8 | 810 (High) | GSM1900 | 28.81 | -0.015 | Standard | Left Ear | 0.894 | 1.048 | 7 |
| 1 880.0 | 661 (Mid) | GSM1900 | 29.12 | -0.157 | Standard | Left Tilt 15° | 0.394 | 0.430 | 8 |
| 1850.2 | 512 (low) | GSM1900 | 29.09 | -0.103 | Standard | Right Ear | 0.940 | 1.033 | 9 |
| 1 880.0 | 661 (Mid) | GSM1900 | 29.12 | -0.152 | Standard | Right Ear | 0.960 | 1.048 | 10 |
| 1909.8 | 810 (High) | GSM1900 | 28.81 | -0.054 | Standard | Right Ear | 0.912 | 1.069 | 11 |
| 1 880.0 | 661 (Mid) | GSM1900 | 29.12 | 0.083 | Standard | Right Tilt 15° | 0.421 | 0.459 | 12 |
| ANSI/ IEEE C95.1 - 1992– Safety Limit Spatial Peak Uncontrolled Exposure/ General Population | | | | | | Head 1.6 W/kg (mW/g) Averaged over 1 gram | | | |

NOTES:

- The test data reported are the worst-case SAR value with the antenna-head position set in a typical configuration. Test procedures used are according to FCC/OET Bulletin 65, Supplement C [July 2001].
- All modes of operation were investigated and the worst-case are reported.
- Measured Depth of Simulating Tissue is 15.0 cm ± 0.2 cm.
- Tissue parameters and temperatures are listed on the SAR plot.
- Battery Type Standard Extended Slim
Batteries are fully charged for all readings.
- Test Signal Call Mode Manual Test cord Base Station Simulator
- According to KDB 447498, Testing of other required channels within the operating mode of a frequency band is not required when the reported 1-g or 10-g SAR for the mid-band or highest output power channel is ≤ 0.8 W/kg or 2.0 W/kg, for 1-g or 10-g respectively, when the transmission band is ≤ 100 MHz.

12.3 Measurement Results (GSM850 Body-Worn SAR)

| Frequency | | Modulation | Conducted Power (dBm) | Power Drift (dB) | Configuration | Separation Distance | Measured SAR(mW/g) | Scaled SAR(mW/g) | Plot No. |
|---|-----------|------------|-----------------------|------------------|---------------|--|--------------------|------------------|----------|
| MHz | Channel | | | | | | | | |
| 836.6 | 190 (Mid) | GSM850 | 32.73 | 0.05 | Rear | 1.5 cm | 0.453 | 0.482 | 13 |
| 836.6 | 190 (Mid) | GSM850 | 32.73 | -0.046 | Front | 1.5 cm | 0.298 | 0.317 | 14 |
| ANSI/ IEEE C95.1 - 1992– Safety Limit Spatial Peak Uncontrolled Exposure/ General Population | | | | | | Body 1.6 W/kg (mW/g) <small>Averaged over 1 gram</small> | | | |

NOTES:

- 1 The test data reported are the worst-case SAR value with the antenna-body position set in a typical configuration. Test procedures used are according to FCC/OET Bulletin 65, Supplement C [July 2001].
- 2 All modes of operation were investigated and the worst-case are reported.
- 3 Measured Depth of Simulating Tissue is 15.0 cm ± 0.2 cm.
- 4 Tissue parameters and temperatures are listed on the SAR plot.
- 5 Battery Type Standard Extended Slim
 Batteries are fully charged for all readings.
- 6 Test Signal Call Mode Manual Test cord Base Station Simulator
- 7 Test Configuration With Holster Without Holster
- 8 Justification for reduced test configurations: per FCC/OET Supplement C (July, 2001), if the SAR measured at the middle channel for each test configuration (Left, right, cheek/touch, tilt/ear, extended and retracted) is at least 3.0 dB lower than the SAR limit, testing at the high and low channels is optional for such test configuration(s).
- 9 Body-Worn accessory testing is typically associated with voice operation. Therefore, GSM voice was evaluated for body-worn SAR.

12.4 Measurement Results (GSM1900 Body-Worn SAR)

| Frequency | | Modulation | Conducted Power (dBm) | Power Drift (dB) | Configuration | Separation Distance | Measured SAR(mW/g) | Scaled SAR(mW/g) | Plot No. |
|---|-----------|------------|-----------------------|------------------|---------------|--|--------------------|------------------|----------|
| MHz | Channel | | | | | | | | |
| 1 880.0 | 661 (Mid) | GSM1900 | 29.12 | 0.178 | Rear | 1.5 cm | 0.451 | 0.492 | 15 |
| 1 880.0 | 661 (Mid) | GSM1900 | 29.12 | 0.07 | Front | 1.5 cm | 0.492 | 0.537 | 16 |
| ANSI/ IEEE C95.1 - 1992– Safety Limit Spatial Peak Uncontrolled Exposure/ General Population | | | | | | Body 1.6 W/kg (mW/g) Averaged over 1 gram | | | |

NOTES:

- 1 The test data reported are the worst-case SAR value with the antenna-body position set in a typical configuration. Test procedures used are according to FCC/OET Bulletin 65, Supplement C [July 2001].
- 2 All modes of operation were investigated and the worst-case are reported.
- 3 Measured Depth of Simulating Tissue is 15.0 cm ± 0.2 cm.
- 4 Tissue parameters and temperatures are listed on the SAR plot.
- 5 Battery Type Standard Extended Slim
Batteries are fully charged for all readings.
- 6 Test Signal Call Mode Manual Test cord Base Station Simulator
- 7 Test Configuration With Holster Without Holster
- 8 Justification for reduced test configurations: per FCC/OET Supplement C (July, 2001), if the SAR measured at the middle channel for each test configuration (Left, right, cheek/touch, tilt/ear, extended and retracted) is at least 3.0 dB lower than the SAR limit, testing at the high and low channels is optional for such test configuration(s).
- 9 Device was tested using a fixed spacing for body-worn accessory testion. A separation distance oh 15mm was considered because the manufacturer has determined that there will be body-worn accessories available in the marketplace for users to support this separation distance.

13. SAR Summation Scenario

| | Position | Applicable Combination |
|---------------------------|-----------|-----------------------------------|
| Simultaneous Transmission | Head | GSM850 Voice + 2.4 GHz Bluetooth |
| | | GSM1900 Voice + 2.4 GHz Bluetooth |
| | Body-worn | GSM850 Voice+ 2.4 GHz Bluetooth |
| | | GSM1900 Voice + 2.4 GHz Bluetooth |

This device contains transmitters that may operate simultaneously. Therefore simultaneous transmission analysis is required. Per FCC KDB 447498 D01v05 IV.C.1iii, simultaneous transmission SAR test exclusion may be applied when the sum of the 1-g SAR for all the simultaneous transmitting antennas in a specific a physical test configuration is $\leq 1.6W/kg$. when standalone SAR is not required to be measured per FCC KDB 447498 D01v05 4.3.22, the following equation must be used to estimate the standalone 1-g SAR for simultaneous transmission assessment involving that transmitter

$$\text{Estimated SAR} = \frac{\sqrt{f(\text{GHz})}}{7.5} * \frac{(\text{Max Power of channel,mW})}{\text{Min.Separation Distance}}$$

| Mode | Frequency | Maximum Allowed Power | Separatuin Distance (Body) | Estimated SAR (Body) |
|-----------------|-----------|-----------------------|----------------------------|----------------------|
| | [MHz] | [mW] | [mm] | [W/kg] |
| Bluetooth(Head) | 2402 | 6.22 | 0 | 0.26 |
| Bluetooth(Body) | 2402 | 6.22 | 10 | 0.13 |

Simultaneous Transmission Summation for Held to Ear

| Simultaneous TX | configuration | GSM850 Scaled SAR(W/kg) | BT SAR (W/kg) | Σ SAR (W/kg) | Simultaneous TX | configuration | GSM1900 Scaled SAR(W/kg) | BT SAR (W/kg) | Σ SAR (W/kg) |
|-----------------|---------------|-------------------------|---------------|---------------------|-----------------|---------------|--------------------------|---------------|---------------------|
| Head SAR | Left Cheek | 0.515 | 0.26 | 0.775 | Head SAR | Left Cheek | 1.05 | 0.26 | 1.310 |
| | Left Tilt | 0.131 | 0.26 | 0.391 | | Left Tilt | 0.43 | 0.26 | 0.690 |
| | Right Cheek | 0.447 | 0.26 | 0.707 | | Right Cheek | 1.069 | 0.26 | 1.329 |
| | Right Tilt | 0.144 | 0.26 | 0.404 | | Right Tilt | 0.459 | 0.26 | 0.719 |

Simultaneous Transmission Summation for Body-Worn (1.5cm)

| Simultaneous TX | configuration | GSM850 Scaled SAR(W/kg) | BT SAR (W/kg) | Σ SAR (W/kg) | Simultaneous TX | configuration | GPRS1900 SAR(W/kg) | BT SAR (W/kg) | Σ SAR (W/kg) |
|-----------------|---------------|-------------------------|---------------|---------------------|-----------------|---------------|--------------------|---------------|---------------------|
| Body SAR | Back | 0.482 | 0.13 | 0.612 | Body SAR | Back | 0.492 | 0.13 | 0.622 |
| | Front | 0.317 | 0.13 | 0.447 | | Front | 0.537 | 0.13 | 0.667 |

Note;

- **Body-Worn SAR** : Although body-worn accessory conditions are typically for voice configurations, the GPRS slot frame averaged output power was more conservative and was included for the body-worn accessory SAR assessment.
- The EUT front body-worn configuration is provided to cover any potential accessory that will position the EUT in this manner.

13.1 Simultaneous Transmission Conclusion

The above numerical summed SAR was below the SAR limit. Therefore, the above analysis is sufficient to determine that simultaneous transmission cases will not exceed the SAR limit. No volumetric SAR summation is required per FCC KDB Publication 648474.

The above tables represent the worst-case simultaneous transmission scenarios possibility with this device.

Per FCC KDB 447498 D01v05, Bluetooth SAR were not required based on the maximum conducted power and the Bluetooth antenna to user separation distance.

$$\frac{\text{Max Power of Channel(mW)}}{\text{Test Separation Dist(mm)}} * \sqrt{\text{Frequency(GHz)}} \leq 3.0$$

| Mode | Frequency | Maximum Allowed Power | Separatuin Distance | ≤ 3.0 |
|-----------------|-----------|-----------------------|---------------------|-------|
| | [MHz] | [mW] | [mm] | |
| Bluetooth(Head) | 2402 | 6.22 | 0 | 1.93 |
| Bluetooth(Body) | 2402 | 6.22 | 10 | 0.96 |

14. SAR Measurement Variability and Uncertainty

In accordance with published RF Exposure KDB procedure 865664 D01 SAR measurement 100 MHz to 6 GHz v01.

These additional measurements are repeated after the completion of all measurements requiring the same head or body tissue-equivalent medium in a frequency band. The test device should be returned to ambient conditions (normal room temperature) with the battery fully charged before it is re-mounted on the device holder for the repeated measurement(s) to minimize any unexpected variations in the repeated results.

- 1) Repeated measurement is not required when the original highest measured SAR is < 0.80 W/kg; steps 2) through 4) do not apply.
- 2) When the original highest measured SAR is ≥ 0.80 W/kg, repeat that measurement once.
- 3) Perform a second repeated measurement only if the ratio of largest to smallest SAR for the original and first repeated measurements is > 1.20 or when the original or repeated measurement is ≥ 1.45 W/kg (~ 10% from the 1-g SAR limit).
- 4) Perform a third repeated measurement only if the original, first or second repeated measurement is ≥ 1.5 W/kg and the ratio of largest to smallest SAR for the original, first and second repeated measurements is > 1.20 .

| Frequency | | Modulation | Battery | Phantom Position | Original SAR(mW/g) | Repeated SAR(mW/g) | Largest to Smallest SAR Ratio | Plot No. |
|-----------|-----------|------------|----------|------------------|--------------------|--------------------|-------------------------------|----------|
| MHz | Channel | | | | | | | |
| 1850.2 | 512 (low) | GSM1900 | Standard | Left Ear | 0.962 | 0.925 | 1.04 | 17 |

Note(s):

1. Second Repeated Measurement is not required since the ratio of the largest to smallest SAR for the original and first repeated measurement is not > 1.20 .
2. Repeated measurement is not required when the original highest measured SAR is < 0.80 W/kg.

15. CONCLUSION

The SAR measurement indicates that the EUT complies with the RF radiation exposure limits of the ANSI/IEEE C95.1 1992.

These measurements are taken to simulate the RF effects exposure under worst-case conditions. Precise laboratory measures were taken to assure repeatability of the tests.

16. REFERENCES

- [1] Federal Communications Commission, OET Bulletin 65 (Edition 97-01), Supplement C (Edition 01-01), Evaluating Compliance with FCC Guidelines for Human Exposure to Radio frequency Electromagnetic Fields, July 2001.
- [2] IEEE Standards Coordinating Committee 34 – IEEE Std. 1528-2003, IEE Recommended Practice or Determining the Peak Spatial-Average Specific Absorption Rate (SAR) in the Human Body from Wireless Communications Devices.
- [3] Federal Communications Commission, ET Docket 93-62, Guidelines for Evaluating the Environmental Effects of Radio frequency Radiation, Aug. 1996.
- [4] ANSI/IEEE C95.1 - 1991, American National Standard safety levels with respect to human exposure to radio frequency electromagnetic fields, 300 kHz to 100 GHz, New York: IEEE, Aug. 1992
- [5] ANSI/IEEE C95.3 - 1991, IEEE Recommended Practice for the Measurement of Potentially Hazardous Electromagnetic Fields - RF and Microwave, New York: IEEE, 1992.
- [6] NCRP, National Council on Radiation Protection and Measurements, Biological Effects and Exposure Criteria for Radio Frequency Electromagnetic Fields, NCRP Report No. 86, 1986. Reprinted Feb. 1995.
- [7] T. Schmid, O. Egger, N. Kuster, Automated E-field scanning system for dosimetric assessments, IEEE Transaction on Microwave Theory and Techniques, vol. 44, Jan. 1996, pp. 105-113.
- [8] K. Pokovic, T. Schmid, N. Kuster, Robust setup for precise calibration of E-field probes in tissue simulating liquids at mobile communications frequencies, ICECOM97, Oct. 1997, pp. 120-124.
- [9] K. Pokovic, T. Schmid, and N. Kuster, E-field Probe with improved isotropy in brain simulating liquids, Proceedings of the ELMAR, Zadar, Croatia, June 23-25, 1996, pp. 172-175.
- [10] Schmid & Partner Engineering AG, Application Note: Data Storage and Evaluation, June 1998, p2.
- [11] V. Hombach, K. Meier, M. Burkhardt, E. Kuhn, N. Kuster, The Dependence of EM Energy Absorption upon Human Head Modeling at 900 MHz, IEEE Transaction on Microwave Theory and Techniques, vol. 44 no. 10, Oct. 1996, pp. 1865-1873.
- [12] N. Kuster and Q. Balzano, Energy absorption mechanism by biological bodies in the near field of dipole antennas above 300 MHz, IEEE Transaction on Vehicular Technology, vol. 41, no. 1, Feb. 1992, pp. 17-23.
- [13] G. Hartsgrove, A. Kraszewski, A. Surowiec, Simulated Biological Materials for Electromagnetic Radiation Absorption Studies, University of Ottawa, Bioelectro magnetics, Canada: 1987, pp. 29-36.
- [14] Q. Balzano, O. Garay, T. Manning Jr., Electromagnetic Energy Exposure of Simulated Users of Portable Cellular Telephones, IEEE Transactions on Vehicular Technology, vol. 44, no.3, Aug. 1995.
- [15] W. Gander, Computer mathematick, Birkhaeuser, Basel, 1992.
- [16] W.H. Press, S.A. Teukolsky, W.T. Vetterling, and B.P. Flannery, Numerical Receptions in C, The Art of Scientific Computing, Second edition, Cambridge University Press, 1992.
- [17] Federal Communications Commission, OET Bulletin 65, Evaluating Compliance with FCC Guidelines for Human Exposure to Radiofrequency Electromagnetic Fields. Supplement C, Dec. 1997.
- [18] N. Kuster, R. Kastle, T. Schmid, Dosimetric evaluation of mobile communications equipment with known precision, IEEE Transaction on Communications, vol. E80-B, no. 5, May 1997, pp. 645-652.
- [19] CENELEC CLC/SC111B, European Prestandard (prENV 50166-2), Human Exposure to Electromagnetic Fields High-frequency: 10 kHz-300 GHz, Jan. 1995.
- [20] Prof. Dr. Niels Kuster, ETH, Eidgenössische Technische Hochschule Zürich, Dosimetric Evaluation of the Cellular Phone.
- [21] SAR Evaluation of Handsets with Multiple Transmitters and Antennas #648474.
- [22] SAR Measurement Procedure for 802.11 a/b/g Transmitters #KDB 248227.

Attachment 1. – SAR Test Plots

Test Laboratory: HCT CO., LTD
EUT Type: 850/1900 GSM/GPRS Phone with Bluetooth v3.0 and EDGE Rx only
Liquid Temperature: 21.3 °C
Ambient Temperature: 21.5 °C
Test Date: Jan. 14, 2013
Plot No.: 1

DUT: GT-S3802; Type: bar; Serial: FK-008-A

Communication System: GSM 850; Frequency: 836.6 MHz; Duty Cycle: 1:8.3
Medium parameters used (interpolated): $f = 836.6$ MHz; $\sigma = 0.92$ mho/m; $\epsilon_r = 40.4$; $\rho = 1000$ kg/m³
Phantom section: Left Section ; Measurement SW: DASY4, V4.7 Build 71; Postprocessing SW: SEMCAD, V1.8 Build 184

DASY4 Configuration:

- Probe: ET3DV6 - SN1605; ConvF(6.64, 6.64, 6.64); Calibrated: 2012-04-26
- Sensor-Surface: 4mm (Mechanical Surface Detection)
- Electronics: DAE4 Sn869; Calibrated: 2012-09-18
- Phantom: SAM 835/900 MHz; Type: SAM

Left Touch 190/Area Scan (61x91x1): Measurement grid: dx=15mm, dy=15mm
Maximum value of SAR (interpolated) = 0.494 mW/g

Left Touch 190/Zoom Scan (5x5x7)/Cube 0: Measurement grid: dx=8mm, dy=8mm, dz=5mm
Reference Value = 6.02 V/m; Power Drift = -0.032 dB
Peak SAR (extrapolated) = 0.744 W/kg
SAR(1 g) = 0.484 mW/g; SAR(10 g) = 0.312 mW/g

Maximum value of SAR (measured) = 0.512 mW/g

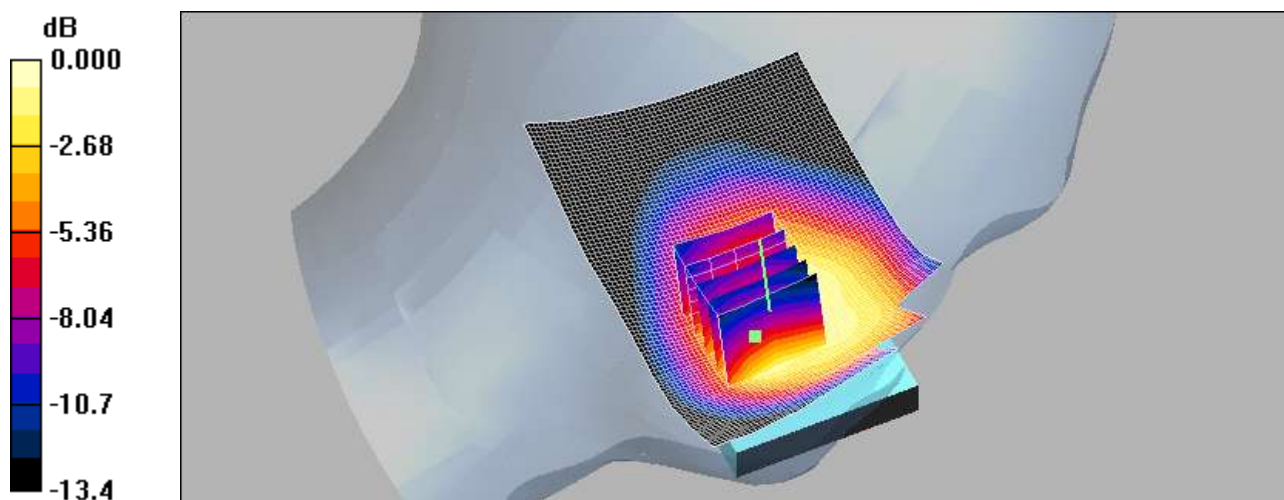

0 dB = 0.512mW/g

Test Laboratory: HCT CO., LTD
EUT Type: 850/1900 GSM/GPRS Phone with Bluetooth v3.0 and EDGE Rx only
Liquid Temperature: 21.3 °C
Ambient Temperature: 21.5 °C
Test Date: Jan. 14, 2013
Plot No.: 2

DUT: GT-S3802; Type: bar; Serial: FK-008-A

Communication System: GSM 850; Frequency: 836.6 MHz; Duty Cycle: 1:8.3
Medium parameters used (interpolated): $f = 836.6$ MHz; $\sigma = 0.92$ mho/m; $\epsilon_r = 40.4$; $\rho = 1000$ kg/m³
Phantom section: Left Section ; Measurement SW: DASY4, V4.7 Build 71; Postprocessing SW: SEMCAD, V1.8 Build 184

DASY4 Configuration:

- Probe: ET3DV6 - SN1605; ConvF(6.64, 6.64, 6.64); Calibrated: 2012-04-26
- Sensor-Surface: 4mm (Mechanical Surface Detection)
- Electronics: DAE4 Sn869; Calibrated: 2012-09-18
- Phantom: SAM 835/900 MHz; Type: SAM

Left Tilt 190/Area Scan (61x91x1): Measurement grid: dx=15mm, dy=15mm
Maximum value of SAR (interpolated) = 0.130 mW/g

Left Tilt 190/Zoom Scan (5x5x7)/Cube 0: Measurement grid: dx=8mm, dy=8mm, dz=5mm
Reference Value = 9.50 V/m; Power Drift = -0.110 dB
Peak SAR (extrapolated) = 0.155 W/kg
SAR(1 g) = 0.123 mW/g; SAR(10 g) = 0.091 mW/g
Maximum value of SAR (measured) = 0.130 mW/g

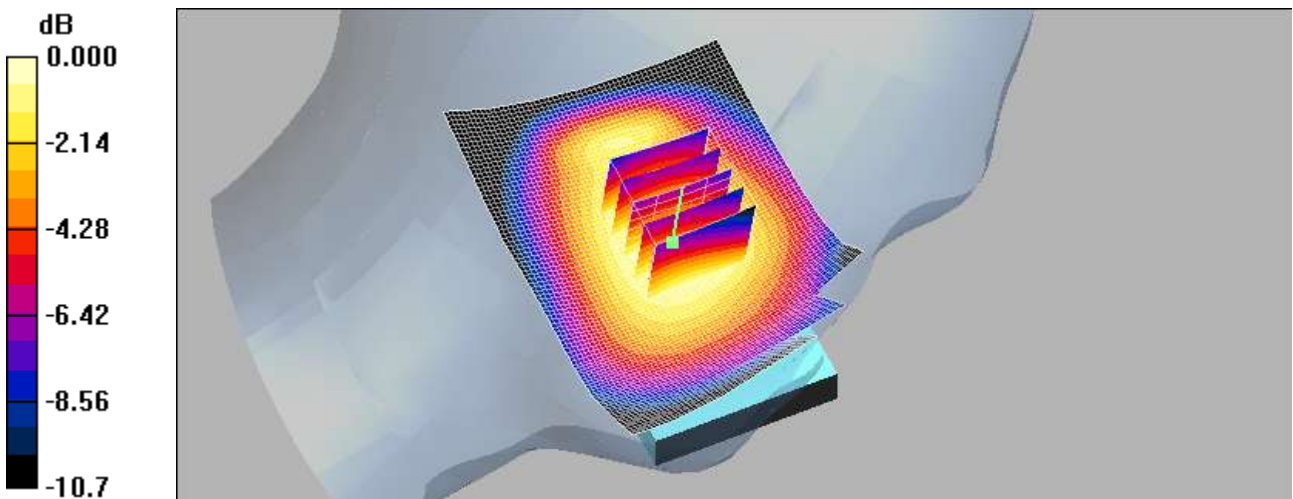

0 dB = 0.130mW/g

Test Laboratory: HCT CO., LTD
EUT Type: 850/1900 GSM/GPRS Phone with Bluetooth v3.0 and EDGE Rx only
Liquid Temperature: 21.3 °C
Ambient Temperature: 21.5 °C
Test Date: Jan. 14, 2013
Plot No.: 3

DUT: GT-S3802; Type: bar; Serial: FK-008-A

Communication System: GSM 850; Frequency: 836.6 MHz; Duty Cycle: 1:8.3
Medium parameters used (interpolated): $f = 836.6$ MHz; $\sigma = 0.92$ mho/m; $\epsilon_r = 40.4$; $\rho = 1000$ kg/m³
Phantom section: Right Section ; Measurement SW: DASY4, V4.7 Build 71; Postprocessing SW: SEMCAD, V1.8 Build 184

DASY4 Configuration:

- Probe: ET3DV6 - SN1605; ConvF(6.64, 6.64, 6.64); Calibrated: 2012-04-26
- Sensor-Surface: 4mm (Mechanical Surface Detection)
- Electronics: DAE4 Sn869; Calibrated: 2012-09-18
- Phantom: SAM 835/900 MHz; Type: SAM

Right Touch 190/Area Scan (61x91x1): Measurement grid: dx=15mm, dy=15mm
Maximum value of SAR (interpolated) = 0.467 mW/g

Right Touch 190/Zoom Scan (5x5x7)/Cube 0: Measurement grid: dx=8mm, dy=8mm, dz=5mm
Reference Value = 5.69 V/m; Power Drift = -0.161 dB
Peak SAR (extrapolated) = 0.948 W/kg
SAR(1 g) = 0.420 mW/g; SAR(10 g) = 0.280 mW/g
Maximum value of SAR (measured) = 0.490 mW/g

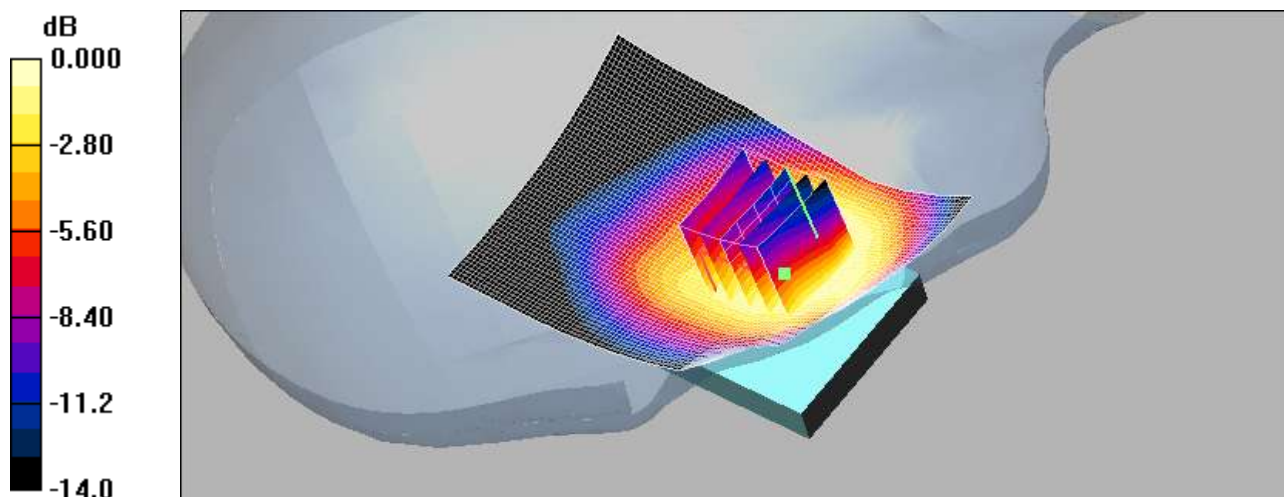

0 dB = 0.490mW/g

Test Laboratory: HCT CO., LTD
EUT Type: 850/1900 GSM/GPRS Phone with Bluetooth v3.0 and EDGE Rx only
Liquid Temperature: 21.3 °C
Ambient Temperature: 21.5 °C
Test Date: Jan. 14, 2013
Plot No.: 4

DUT: GT-S3802; Type: bar; Serial: FK-008-A

Communication System: GSM 850; Frequency: 836.6 MHz; Duty Cycle: 1:8.3
Medium parameters used (interpolated): $f = 836.6$ MHz; $\sigma = 0.92$ mho/m; $\epsilon_r = 40.4$; $\rho = 1000$ kg/m³
Phantom section: Right Section ; Measurement SW: DASY4, V4.7 Build 71; Postprocessing SW: SEMCAD, V1.8 Build 184

DASY4 Configuration:

- Probe: ET3DV6 - SN1605; ConvF(6.64, 6.64, 6.64); Calibrated: 2012-04-26
- Sensor-Surface: 4mm (Mechanical Surface Detection)
- Electronics: DAE4 Sn869; Calibrated: 2012-09-18
- Phantom: SAM 835/900 MHz; Type: SAM

Right Tilt 190/Area Scan (61x91x1): Measurement grid: dx=15mm, dy=15mm
Maximum value of SAR (interpolated) = 0.142 mW/g

Right Tilt 190/Zoom Scan (5x5x7)/Cube 0: Measurement grid: dx=8mm, dy=8mm, dz=5mm
Reference Value = 9.88 V/m; Power Drift = 0.060 dB
Peak SAR (extrapolated) = 0.168 W/kg
SAR(1 g) = 0.135 mW/g; SAR(10 g) = 0.099 mW/g
Maximum value of SAR (measured) = 0.143 mW/g

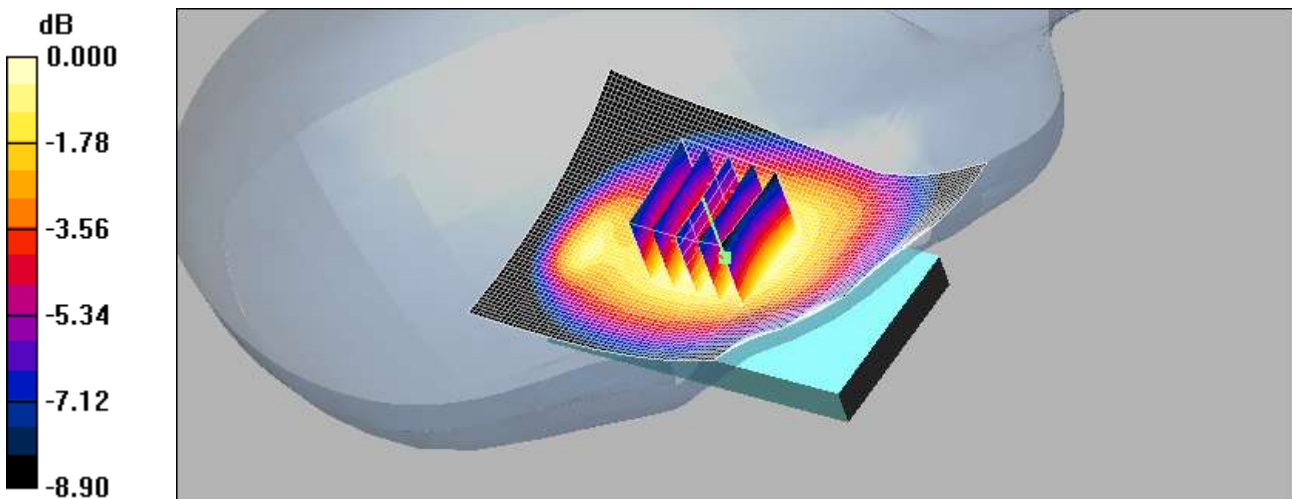

0 dB = 0.143mW/g

Test Laboratory: HCT CO., LTD
EUT Type: 850/1900 GSM/GPRS Phone with Bluetooth v3.0 and EDGE Rx only
Liquid Temperature: 21.2 °C
Ambient Temperature: 21.4 °C
Test Date: Jan. 15, 2013
Plot No.: 5

DUT: GT-S3802; Type: bar; Serial: FK-008-A

Communication System: GSM 1900; Frequency: 1850.2 MHz; Duty Cycle: 1:8.3
Medium parameters used (interpolated): $f = 1850.2 \text{ MHz}$; $\sigma = 1.32 \text{ mho/m}$; $\epsilon_r = 41$; $\rho = 1000 \text{ kg/m}^3$
Phantom section: Left Section ; Measurement SW: DASY4, V4.7 Build 71; Postprocessing SW: SEMCAD, V1.8 Build 184

DASY4 Configuration:

- Probe: ET3DV6 - SN1605; ConvF(5.26, 5.26, 5.26); Calibrated: 2012-04-26
- Sensor-Surface: 4mm (Mechanical Surface Detection)
- Electronics: DAE4 Sn869; Calibrated: 2012-09-18
- Phantom: SAM 1800/1900 MHz; Type: SAM

Left Touch 512/Area Scan (61x91x1): Measurement grid: dx=15mm, dy=15mm

Maximum value of SAR (interpolated) = 1.12 mW/g

Left Touch 512/Zoom Scan (5x5x7)/Cube 0: Measurement grid: dx=8mm, dy=8mm, dz=5mm

Reference Value = 11.3 V/m; Power Drift = -0.042 dB

Peak SAR (extrapolated) = 1.56 W/kg

SAR(1 g) = 0.918 mW/g; SAR(10 g) = 0.504 mW/g

Maximum value of SAR (measured) = 1.03 mW/g

Left Touch 512/Zoom Scan (5x5x7)/Cube 1: Measurement grid: dx=8mm, dy=8mm, dz=5mm

Reference Value = 11.3 V/m; Power Drift = -0.042 dB

Peak SAR (extrapolated) = 1.36 W/kg

SAR(1 g) = 0.768 mW/g; SAR(10 g) = 0.431 mW/g

Maximum value of SAR (measured) = 0.937 mW/g

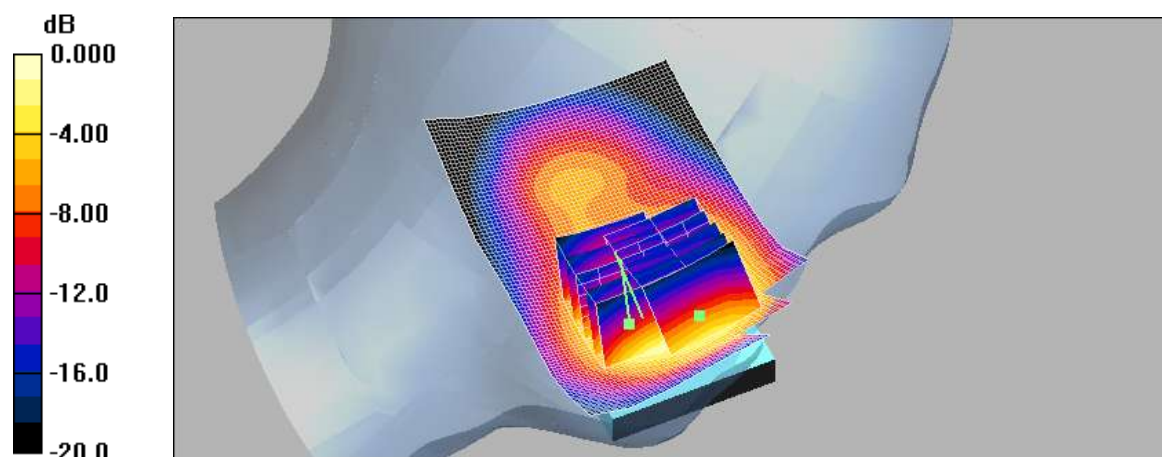

0 dB = 0.937mW/g

Test Laboratory: HCT CO., LTD
EUT Type: 850/1900 GSM/GPRS Phone with Bluetooth v3.0 and EDGE Rx only
Liquid Temperature: 21.2 °C
Ambient Temperature: 21.4 °C
Test Date: Jan. 15, 2013
Plot No.: 6

DUT: GT-S3802; Type: bar; Serial: FK-008-A

Communication System: GSM 1900; Frequency: 1880 MHz; Duty Cycle: 1:8.3
Medium parameters used: $f = 1880$ MHz; $\sigma = 1.35$ mho/m; $\epsilon_r = 40.9$; $\rho = 1000$ kg/m³
Phantom section: Left Section ; Measurement SW: DASY4, V4.7 Build 71; Postprocessing SW: SEMCAD, V1.8 Build 184

DASY4 Configuration:

- Probe: ET3DV6 - SN1605; ConvF(5.26, 5.26, 5.26); Calibrated: 2012-04-26
- Sensor-Surface: 4mm (Mechanical Surface Detection)
- Electronics: DAE4 Sn869; Calibrated: 2012-09-18
- Phantom: SAM 1800/1900 MHz; Type: SAM

Left Touch 661/Area Scan (61x91x1): Measurement grid: dx=15mm, dy=15mm

Maximum value of SAR (interpolated) = 1.17 mW/g

Left Touch 661/Zoom Scan (5x5x7)/Cube 0: Measurement grid: dx=8mm, dy=8mm, dz=5mm

Reference Value = 11.8 V/m; Power Drift = -0.262 dB

Peak SAR (extrapolated) = 1.66 W/kg

SAR(1 g) = 0.962 mW/g; SAR(10 g) = 0.529 mW/g

Maximum value of SAR (measured) = 1.08 mW/g

Left Touch 661/Zoom Scan (5x5x7)/Cube 1: Measurement grid: dx=8mm, dy=8mm, dz=5mm

Reference Value = 11.8 V/m; Power Drift = -0.062 dB

Peak SAR (extrapolated) = 1.46 W/kg

SAR(1 g) = 0.813 mW/g; SAR(10 g) = 0.457 mW/g

Maximum value of SAR (measured) = 0.998 mW/g

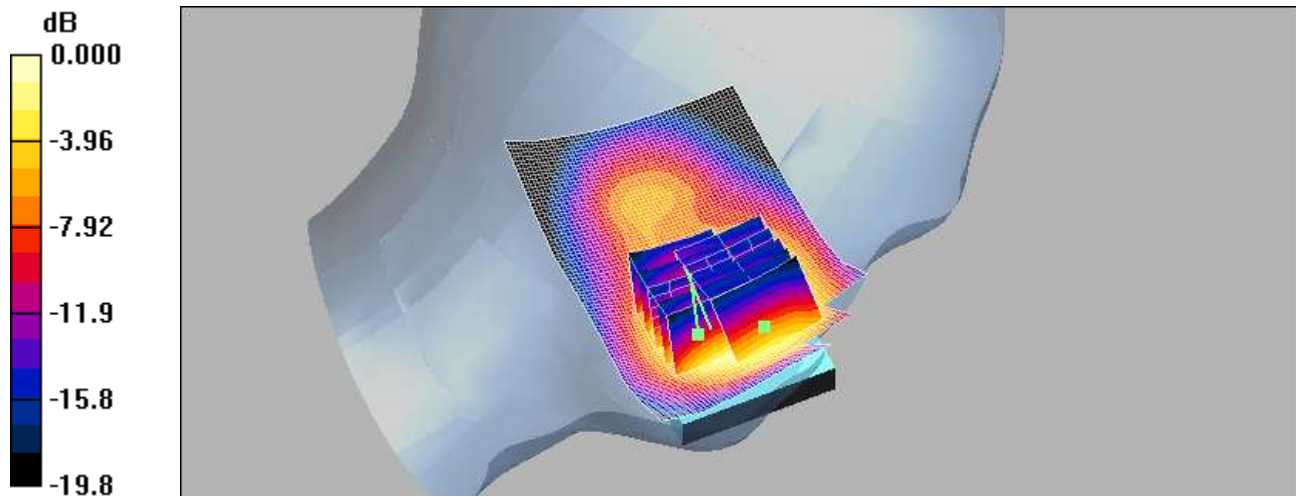

0 dB = 0.998mW/g

Test Laboratory: HCT CO., LTD
EUT Type: 850/1900 GSM/GPRS Phone with Bluetooth v3.0 and EDGE Rx only
Liquid Temperature: 21.2 °C
Ambient Temperature: 21.4 °C
Test Date: Jan. 15, 2013
Plot No.: 7

DUT: GT-S3802; Type: bar; Serial: FK-008-A

Communication System: GSM 1900; Frequency: 1909.8 MHz; Duty Cycle: 1:8.3
Medium parameters used: $f = 1910$ MHz; $\sigma = 1.38$ mho/m; $\epsilon_r = 40.8$; $\rho = 1000$ kg/m³
Phantom section: Left Section ; Measurement SW: DASY4, V4.7 Build 71; Postprocessing SW: SEMCAD, V1.8 Build 184

DASY4 Configuration:

- Probe: ET3DV6 - SN1605; ConvF(5.26, 5.26, 5.26); Calibrated: 2012-04-26
- Sensor-Surface: 4mm (Mechanical Surface Detection)
- Electronics: DAE4 Sn869; Calibrated: 2012-09-18
- Phantom: SAM 1800/1900 MHz; Type: SAM

Left Touch 810/Area Scan (61x91x1): Measurement grid: dx=15mm, dy=15mm
Maximum value of SAR (interpolated) = 1.00 mW/g

Left Touch 810/Zoom Scan (5x5x7)/Cube 0: Measurement grid: dx=8mm, dy=8mm, dz=5mm
Reference Value = 10.9 V/m; Power Drift = -0.015 dB
Peak SAR (extrapolated) = 1.55 W/kg
SAR(1 g) = 0.894 mW/g; SAR(10 g) = 0.487 mW/g
Maximum value of SAR (measured) = 0.965 mW/g

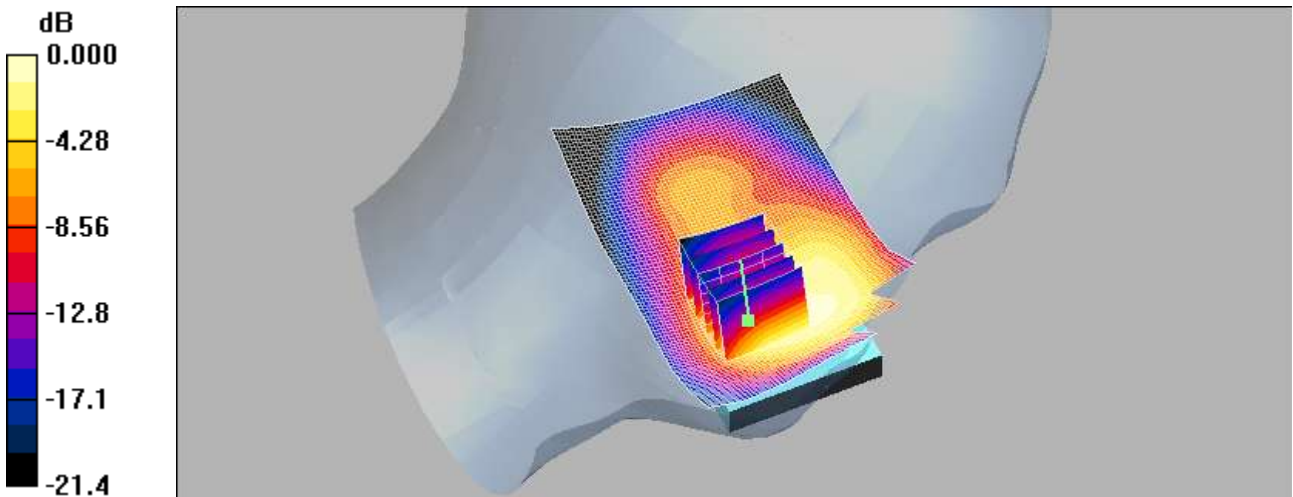

0 dB = 0.965mW/g

Test Laboratory: HCT CO., LTD
EUT Type: 850/1900 GSM/GPRS Phone with Bluetooth v3.0 and EDGE Rx only
Liquid Temperature: 21.2 °C
Ambient Temperature: 21.4 °C
Test Date: Jan. 15, 2013
Plot No.: 8

DUT: GT-S3802; Type: bar; Serial: FK-008-A

Communication System: GSM 1900; Frequency: 1880 MHz; Duty Cycle: 1:8.3
Medium parameters used: $f = 1880 \text{ MHz}$; $\sigma = 1.35 \text{ mho/m}$; $\epsilon_r = 40.9$; $\rho = 1000 \text{ kg/m}^3$
Phantom section: Left Section ; Measurement SW: DASY4, V4.7 Build 71; Postprocessing SW: SEMCAD, V1.8 Build 184

DASY4 Configuration:

- Probe: ET3DV6 - SN1605; ConvF(5.26, 5.26, 5.26); Calibrated: 2012-04-26
- Sensor-Surface: 4mm (Mechanical Surface Detection)
- Electronics: DAE4 Sn869; Calibrated: 2012-09-18
- Phantom: SAM 1800/1900 MHz; Type: SAM

Left Tilt 661/Area Scan (61x91x1): Measurement grid: dx=15mm, dy=15mm
Maximum value of SAR (interpolated) = 0.444 mW/g

Left Tilt 661/Zoom Scan (5x5x7)/Cube 0: Measurement grid: dx=8mm, dy=8mm, dz=5mm
Reference Value = 16.7 V/m; Power Drift = -0.157 dB
Peak SAR (extrapolated) = 0.676 W/kg
SAR(1 g) = 0.394 mW/g; SAR(10 g) = 0.220 mW/g
Maximum value of SAR (measured) = 0.413 mW/g

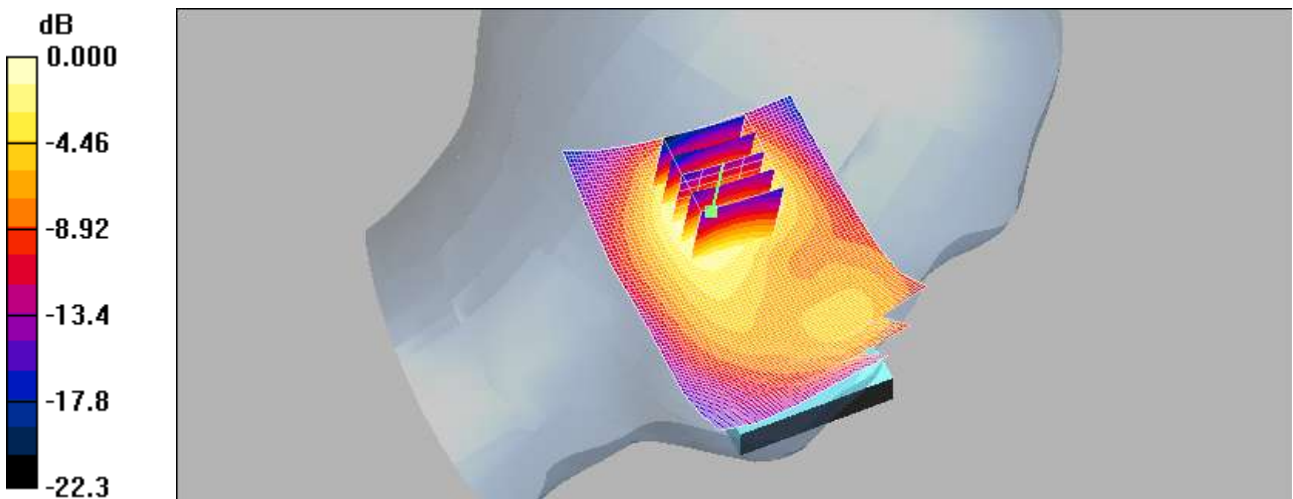

0 dB = 0.413mW/g

Test Laboratory: HCT CO., LTD
EUT Type: 850/1900 GSM/GPRS Phone with Bluetooth v3.0 and EDGE Rx only
Liquid Temperature: 21.2 °C
Ambient Temperature: 21.4 °C
Test Date: Jan. 15, 2013
Plot No.: 9

DUT: GT-S3802; Type: bar; Serial: FK-008-A

Communication System: GSM 1900; Frequency: 1850.2 MHz; Duty Cycle: 1:8.3
Medium parameters used (interpolated): $f = 1850.2 \text{ MHz}$; $\sigma = 1.32 \text{ mho/m}$; $\epsilon_r = 41$; $\rho = 1000 \text{ kg/m}^3$
Phantom section: Right Section ; Measurement SW: DASY4, V4.7 Build 71; Postprocessing SW: SEMCAD, V1.8 Build 184

DASY4 Configuration:

- Probe: ET3DV6 - SN1605; ConvF(5.26, 5.26, 5.26); Calibrated: 2012-04-26
- Sensor-Surface: 4mm (Mechanical Surface Detection)
- Electronics: DAE4 Sn869; Calibrated: 2012-09-18
- Phantom: SAM 1800/1900 MHz; Type: SAM

Right Touch 512/Area Scan (61x91x1): Measurement grid: dx=15mm, dy=15mm
Maximum value of SAR (interpolated) = 1.06 mW/g

Right Touch 512/Zoom Scan (5x5x7)/Cube 0: Measurement grid: dx=8mm, dy=8mm, dz=5mm
Reference Value = 7.91 V/m; Power Drift = -0.103 dB
Peak SAR (extrapolated) = 1.61 W/kg
SAR(1 g) = 0.940 mW/g; SAR(10 g) = 0.514 mW/g
Maximum value of SAR (measured) = 1.01 mW/g

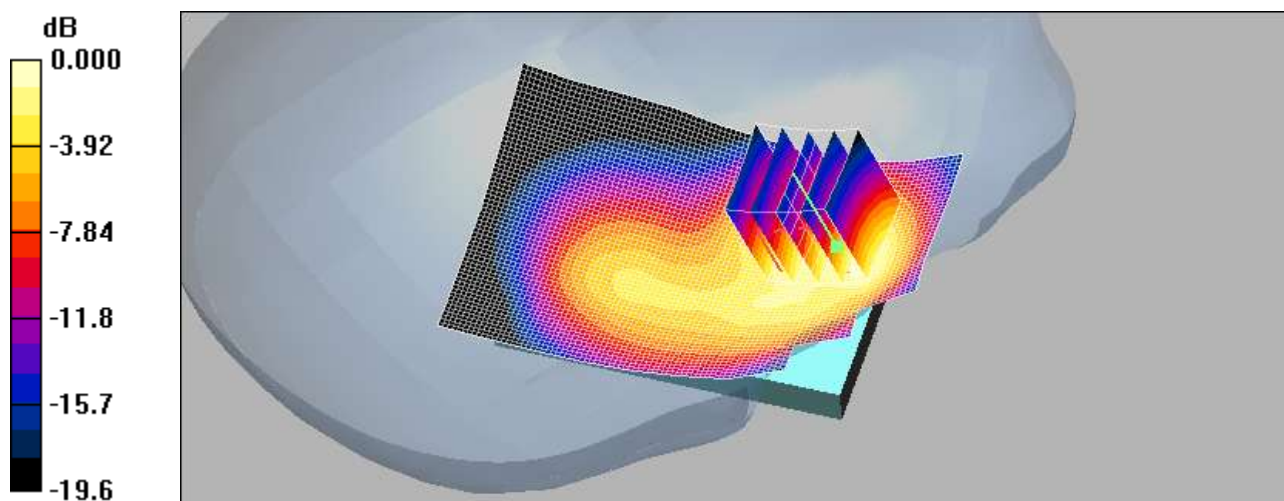

0 dB = 1.01mW/g

Test Laboratory: HCT CO., LTD
EUT Type: 850/1900 GSM/GPRS Phone with Bluetooth v3.0 and EDGE Rx only
Liquid Temperature: 21.2 °C
Ambient Temperature: 21.4 °C
Test Date: Jan. 15, 2013
Plot No.: 10

DUT: GT-S3802; Type: bar; Serial: FK-008-A

Communication System: GSM 1900; Frequency: 1880 MHz; Duty Cycle: 1:8.3
Medium parameters used: $f = 1880$ MHz; $\sigma = 1.35$ mho/m; $\epsilon_r = 40.9$; $\rho = 1000$ kg/m³
Phantom section: Right Section ; Measurement SW: DASY4, V4.7 Build 71; Postprocessing SW: SEMCAD, V1.8 Build 184

DASY4 Configuration:

- Probe: ET3DV6 - SN1605; ConvF(5.26, 5.26, 5.26); Calibrated: 2012-04-26
- Sensor-Surface: 4mm (Mechanical Surface Detection)
- Electronics: DAE4 Sn869; Calibrated: 2012-09-18
- Phantom: SAM 1800/1900 MHz; Type: SAM

Right Touch 661/Area Scan (61x91x1): Measurement grid: dx=15mm, dy=15mm
Maximum value of SAR (interpolated) = 1.08 mW/g

Right Touch 661/Zoom Scan (5x5x7)/Cube 0: Measurement grid: dx=8mm, dy=8mm, dz=5mm
Reference Value = 7.98 V/m; Power Drift = -0.152 dB
Peak SAR (extrapolated) = 1.65 W/kg
SAR(1 g) = 0.960 mW/g; SAR(10 g) = 0.524 mW/g
Maximum value of SAR (measured) = 1.05 mW/g

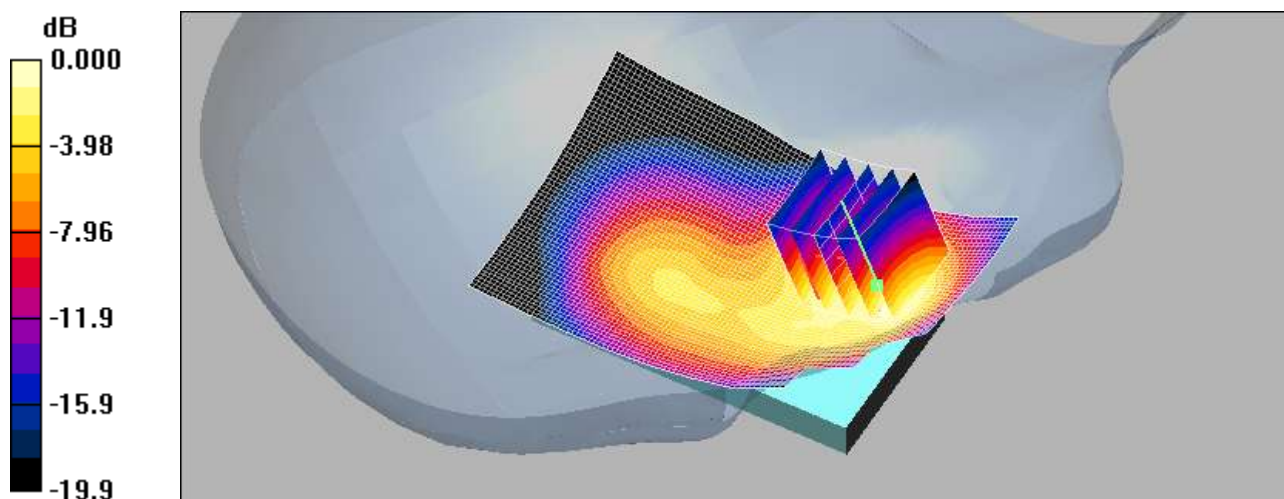

0 dB = 1.05mW/g

Test Laboratory: HCT CO., LTD
EUT Type: 850/1900 GSM/GPRS Phone with Bluetooth v3.0 and EDGE Rx only
Liquid Temperature: 21.2 °C
Ambient Temperature: 21.4 °C
Test Date: Jan. 15, 2013
Plot No.: 11

DUT: GT-S3802; Type: bar; Serial: FK-008-A

Communication System: GSM 1900; Frequency: 1909.8 MHz; Duty Cycle: 1:8.3
Medium parameters used: $f = 1910$ MHz; $\sigma = 1.38$ mho/m; $\epsilon_r = 40.8$; $\rho = 1000$ kg/m³
Phantom section: Right Section ; Measurement SW: DASY4, V4.7 Build 71; Postprocessing SW: SEMCAD, V1.8 Build 184

DASY4 Configuration:

- Probe: ET3DV6 - SN1605; ConvF(5.26, 5.26, 5.26); Calibrated: 2012-04-26
- Sensor-Surface: 4mm (Mechanical Surface Detection)
- Electronics: DAE4 Sn869; Calibrated: 2012-09-18
- Phantom: SAM 1800/1900 MHz; Type: SAM

Right Touch 810/Area Scan (61x91x1): Measurement grid: dx=15mm, dy=15mm
Maximum value of SAR (interpolated) = 1.04 mW/g

Right Touch 810/Zoom Scan (5x5x7)/Cube 0: Measurement grid: dx=8mm, dy=8mm, dz=5mm
Reference Value = 6.85 V/m; Power Drift = -0.054 dB
Peak SAR (extrapolated) = 1.60 W/kg
SAR(1 g) = 0.912 mW/g; SAR(10 g) = 0.492 mW/g
Maximum value of SAR (measured) = 0.987 mW/g

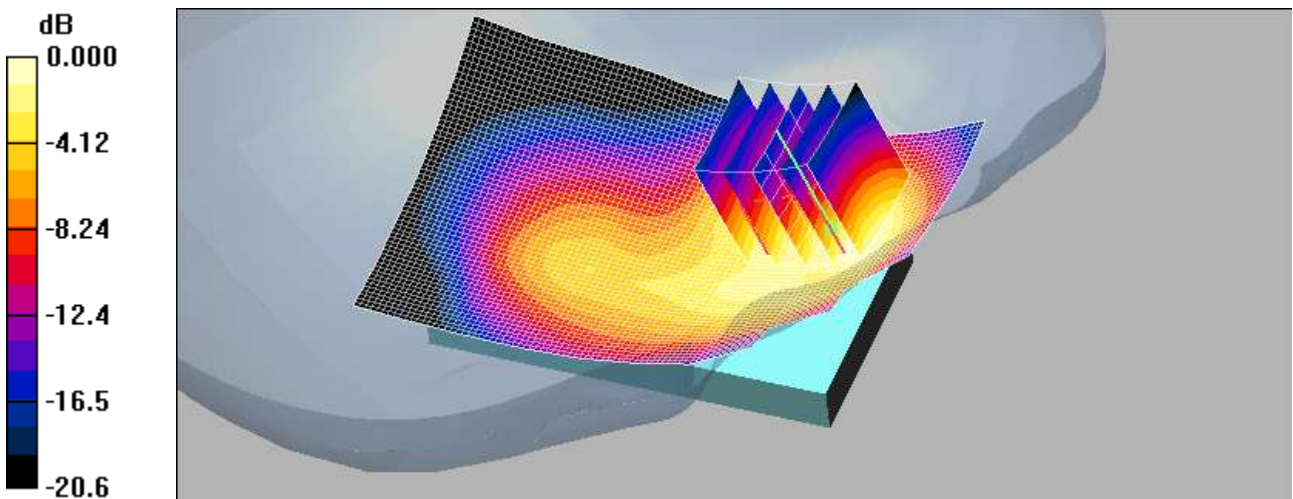

0 dB = 0.987mW/g

Test Laboratory: HCT CO., LTD
EUT Type: 850/1900 GSM/GPRS Phone with Bluetooth v3.0 and EDGE Rx only
Liquid Temperature: 21.2 °C
Ambient Temperature: 21.4 °C
Test Date: Jan. 15, 2013
Plot No.: 12

DUT: GT-S3802; Type: bar; Serial: FK-008-A

Communication System: GSM 1900; Frequency: 1880 MHz; Duty Cycle: 1:8.3
Medium parameters used: $f = 1880 \text{ MHz}$; $\sigma = 1.35 \text{ mho/m}$; $\epsilon_r = 40.9$; $\rho = 1000 \text{ kg/m}^3$
Phantom section: Right Section ; Measurement SW: DASY4, V4.7 Build 71; Postprocessing SW: SEMCAD, V1.8 Build 184

DASY4 Configuration:

- Probe: ET3DV6 - SN1605; ConvF(5.26, 5.26, 5.26); Calibrated: 2012-04-26
- Sensor-Surface: 4mm (Mechanical Surface Detection)
- Electronics: DAE4 Sn869; Calibrated: 2012-09-18
- Phantom: SAM 1800/1900 MHz; Type: SAM

Right Tilt 661/Area Scan (61x91x1): Measurement grid: dx=15mm, dy=15mm
Maximum value of SAR (interpolated) = 0.537 mW/g

Right Tilt 661/Zoom Scan (5x5x7)/Cube 0: Measurement grid: dx=8mm, dy=8mm, dz=5mm
Reference Value = 13.4 V/m; Power Drift = 0.083 dB
Peak SAR (extrapolated) = 0.780 W/kg
SAR(1 g) = 0.421 mW/g; SAR(10 g) = 0.236 mW/g
Maximum value of SAR (measured) = 0.453 mW/g

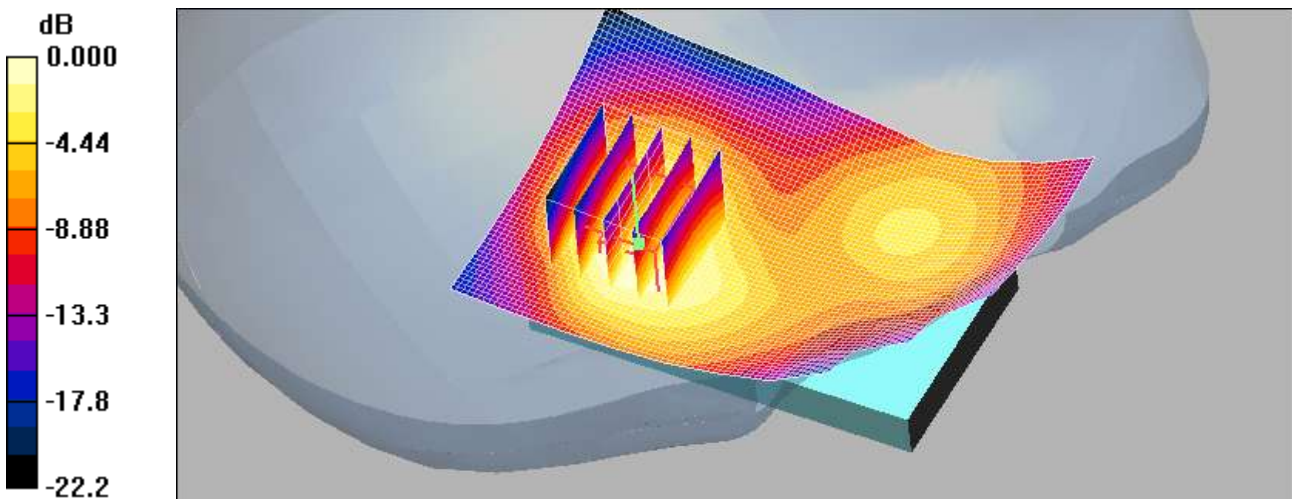

0 dB = 0.453mW/g

Test Laboratory: HCT CO., LTD
EUT Type: 850/1900 GSM/GPRS Phone with Bluetooth v3.0 and EDGE Rx only
Liquid Temperature: 21.3 °C
Ambient Temperature: 21.5 °C
Test Date: Jan. 14, 2013
Plot No.: 13

DUT: GT-S3802; Type: bar; Serial: FK-008-A

Communication System: GSM 850; Frequency: 836.6 MHz; Duty Cycle: 1:8.3
Medium parameters used (interpolated): $f = 836.6$ MHz; $\sigma = 0.986$ mho/m; $\epsilon_r = 57.1$; $\rho = 1000$ kg/m³
Phantom section: Center Section ; Measurement SW: DASY4, V4.7 Build 71; Postprocessing SW: SEMCAD, V1.8 Build 184

DASY4 Configuration:

- Probe: ET3DV6 - SN1605; ConvF(6.52, 6.52, 6.52); Calibrated: 2012-04-26
- Sensor-Surface: 4mm (Mechanical Surface Detection)
- Electronics: DAE4 Sn869; Calibrated: 2012-09-18
- Phantom: Triple Flat Phantom 5.1C; Type: QD 000 P51 CA

Rear 190/Area Scan (61x91x1): Measurement grid: dx=15mm, dy=15mm

Maximum value of SAR (interpolated) = 0.492 mW/g

Rear 190/Zoom Scan (5x5x7)/Cube 0: Measurement grid: dx=8mm, dy=8mm, dz=5mm

Reference Value = 5.87 V/m; Power Drift = -0.05 dB

Peak SAR (extrapolated) = 0.659 W/kg

SAR(1 g) = 0.453 mW/g; SAR(10 g) = 0.300 mW/g

Maximum value of SAR (measured) = 0.486 mW/g

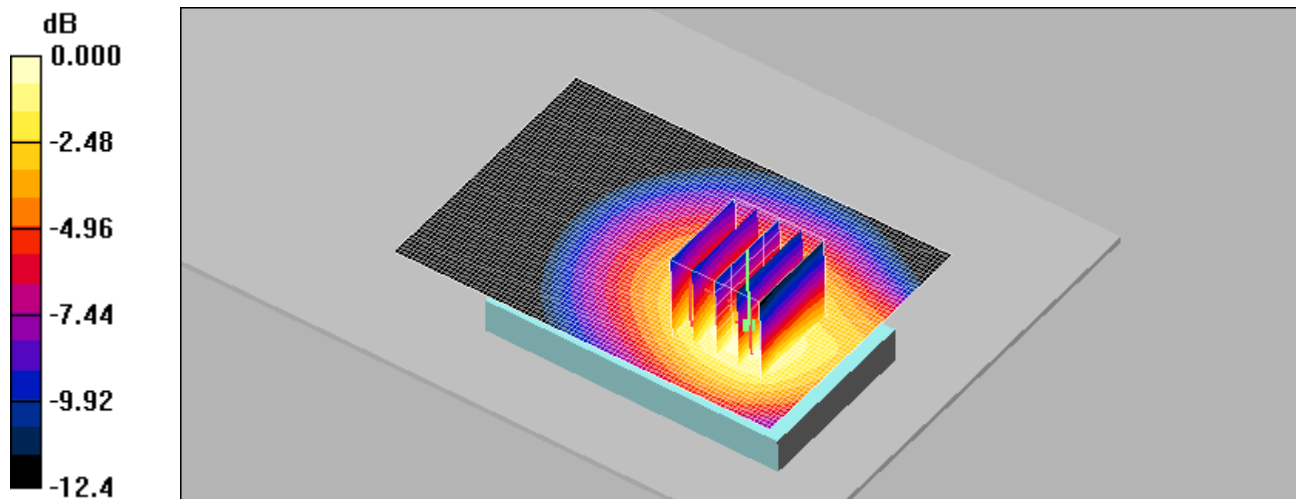

0 dB = 0.486mW/g

Test Laboratory: HCT CO., LTD
EUT Type: 850/1900 GSM/GPRS Phone with Bluetooth v3.0 and EDGE Rx only
Liquid Temperature: 21.3 °C
Ambient Temperature: 21.5 °C
Test Date: Jan. 14, 2013
Plot No.: 14

DUT: GT-S3802; Type: bar; Serial: FK-008-A

Communication System: GSM 850; Frequency: 836.6 MHz; Duty Cycle: 1:8.3
Medium parameters used (interpolated): $f = 836.6$ MHz; $\sigma = 0.986$ mho/m; $\epsilon_r = 57.1$; $\rho = 1000$ kg/m³
Phantom section: Center Section ; Measurement SW: DASY4, V4.7 Build 71; Postprocessing SW: SEMCAD, V1.8 Build 184

DASY4 Configuration:

- Probe: ET3DV6 - SN1605; ConvF(6.52, 6.52, 6.52); Calibrated: 2012-04-26
- Sensor-Surface: 4mm (Mechanical Surface Detection)
- Electronics: DAE4 Sn869; Calibrated: 2012-09-18
- Phantom: Triple Flat Phantom 5.1C; Type: QD 000 P51 CA

Front 190/Area Scan (61x91x1): Measurement grid: dx=15mm, dy=15mm

Maximum value of SAR (interpolated) = 0.323 mW/g

Front 190/Zoom Scan (5x5x7)/Cube 0: Measurement grid: dx=8mm, dy=8mm, dz=5mm

Reference Value = 4.19 V/m; Power Drift = -0.046 dB

Peak SAR (extrapolated) = 0.442 W/kg

SAR(1 g) = 0.298 mW/g; SAR(10 g) = 0.198 mW/g

Maximum value of SAR (measured) = 0.322 mW/g

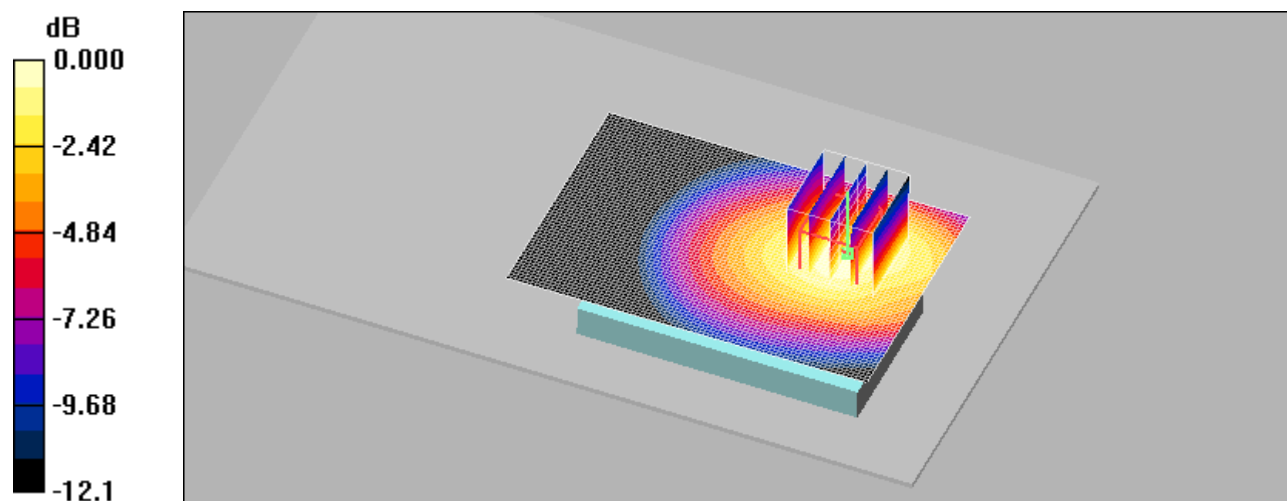

0 dB = 0.322mW/g

Test Laboratory: HCT CO., LTD

EUT Type: 850/1900 GSM/GPRS Phone with Bluetooth v3.0 and EDGE Rx only
Liquid Temperature: 21.2 °C
Ambient Temperature: 21.4 °C
Test Date: Jan. 15, 2013
Plot No.: 15

DUT: GT-S3802; Type: bar; Serial: FK-008-A

Communication System: GSM1900; Frequency: 1880 MHz; Duty Cycle: 1:8.3
Medium parameters used: $f = 1880 \text{ MHz}$; $\sigma = 1.53 \text{ mho/m}$; $\epsilon_r = 52.1$; $\rho = 1000 \text{ kg/m}^3$
Phantom section: Center Section ; Measurement SW: DASY4, V4.7 Build 71; Postprocessing SW: SEMCAD, V1.8 Build 184

DASY4 Configuration:

- Probe: ET3DV6 - SN1605; ConvF(4.64, 4.64, 4.64); Calibrated: 2012-04-26
- Sensor-Surface: 4mm (Mechanical Surface Detection)
- Electronics: DAE4 Sn869; Calibrated: 2012-09-18
- Phantom: Triple Flat Phantom 5.1C; Type: QD 000 P51 CA

Rear 661/Area Scan (61x91x1): Measurement grid: dx=15mm, dy=15mm
Maximum value of SAR (interpolated) = 0.510 mW/g

Rear 661/Zoom Scan (5x5x7)/Cube 0: Measurement grid: dx=8mm, dy=8mm, dz=5mm
Reference Value = 14.1 V/m; Power Drift = -0.082 dB
Peak SAR (extrapolated) = 0.741 W/kg
SAR(1 g) = 0.451 mW/g; SAR(10 g) = 0.267 mW/g
Maximum value of SAR (measured) = 0.487 mW/g

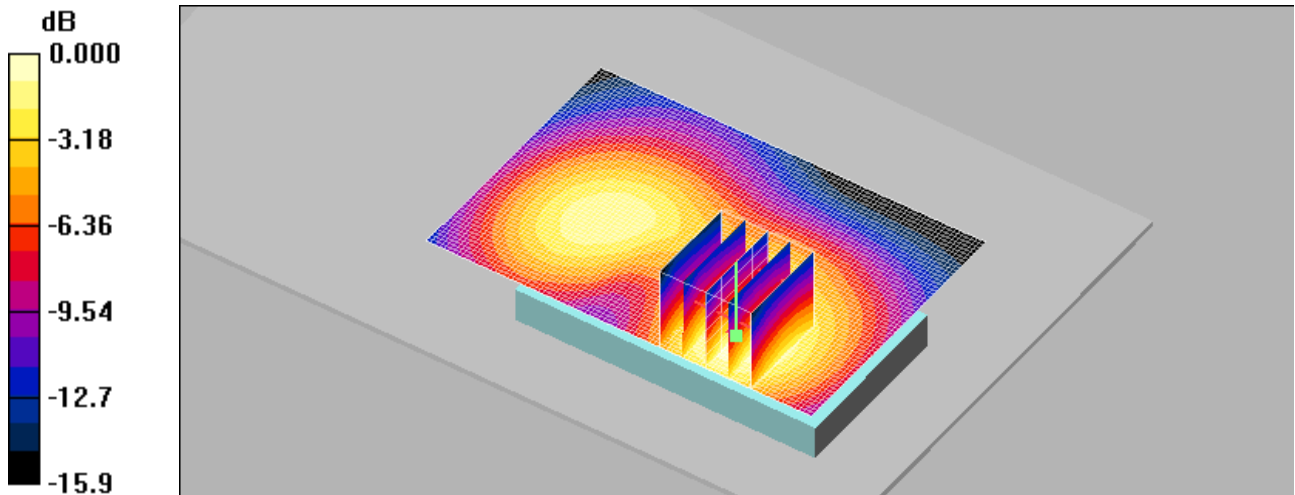

0 dB = 0.487mW/g

Test Laboratory: HCT CO., LTD
EUT Type: 850/1900 GSM/GPRS Phone with Bluetooth v3.0 and EDGE Rx only
Liquid Temperature: 21.2 °C

Ambient Temperature: 21.4 °C
Test Date: Jan. 15, 2013
Plot No.: 16

DUT: GT-S3802; Type: bar; Serial: FK-008-A

Communication System: GSM1900; Frequency: 1880 MHz; Duty Cycle: 1:8.3
Medium parameters used: $f = 1880$ MHz; $\sigma = 1.53$ mho/m; $\epsilon_r = 52.1$; $\rho = 1000$ kg/m³
Phantom section: Center Section ; Measurement SW: DASY4, V4.7 Build 71; Postprocessing SW: SEMCAD, V1.8 Build 184

DASY4 Configuration:

- Probe: ET3DV6 - SN1605; ConvF(4.64, 4.64, 4.64); Calibrated: 2012-04-26
- Sensor-Surface: 4mm (Mechanical Surface Detection)
- Electronics: DAE4 Sn869; Calibrated: 2012-09-18
- Phantom: Triple Flat Phantom 5.1C; Type: QD 000 P51 CA

Front 661/Area Scan (61x91x1): Measurement grid: dx=15mm, dy=15mm
Maximum value of SAR (interpolated) = 0.558 mW/g

Front 661/Zoom Scan (5x5x7)/Cube 0: Measurement grid: dx=8mm, dy=8mm, dz=5mm
Reference Value = 12.3 V/m; Power Drift = 0.07 dB
Peak SAR (extrapolated) = 0.790 W/kg
SAR(1 g) = 0.492 mW/g; SAR(10 g) = 0.296 mW/g
Maximum value of SAR (measured) = 0.532 mW/g

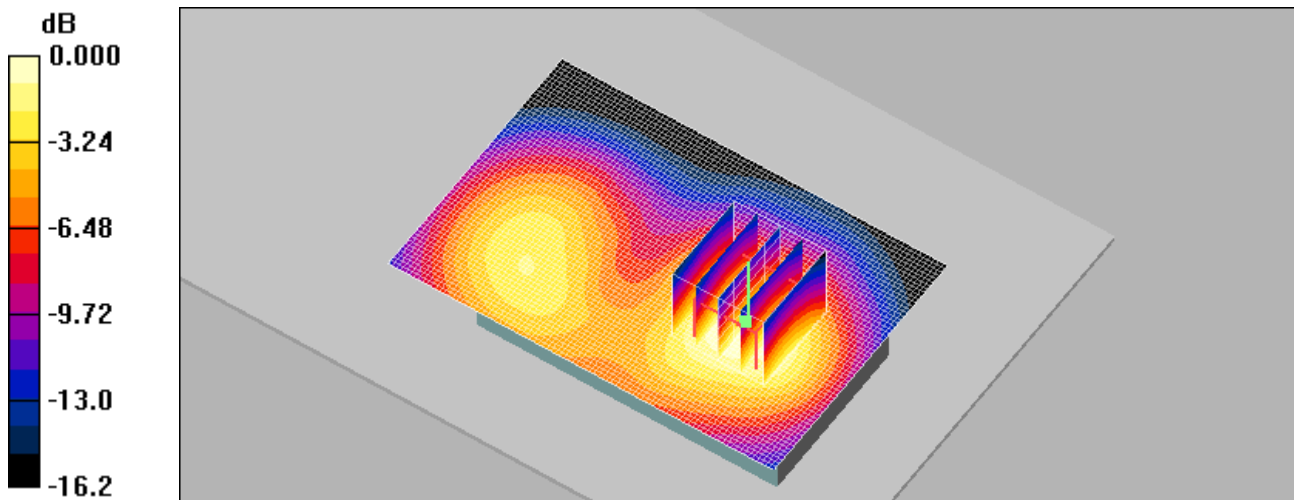

0 dB = 0.532mW/g

Test Laboratory: HCT CO., LTD
EUT Type: 850/1900 GSM/GPRS Phone with Bluetooth v3.0 and EDGE Rx only
Liquid Temperature: 21.2 °C
Ambient Temperature: 21.4 °C
Test Date: Jan. 15, 2013
Plot No.: 17
Repeated SAR

DUT: GT-S3802; Type: bar; Serial: FK-008-A

Communication System: GSM 1900; Frequency: 1880 MHz; Duty Cycle: 1:8.3
Medium parameters used: $f = 1880$ MHz; $\sigma = 1.35$ mho/m; $\epsilon_r = 40.9$; $\rho = 1000$ kg/m³
Phantom section: Left Section ; Measurement SW: DASY4, V4.7 Build 71; Postprocessing SW: SEMCAD, V1.8 Build 184

DASY4 Configuration:

- Probe: ET3DV6 - SN1605; ConvF(5.26, 5.26, 5.26); Calibrated: 2012-04-26
- Sensor-Surface: 4mm (Mechanical Surface Detection)
- Electronics: DAE4 Sn869; Calibrated: 2012-09-18
- Phantom: SAM 1800/1900 MHz; Type: SAM

Left Touch 661/Area Scan (61x91x1): Measurement grid: dx=15mm, dy=15mm

Maximum value of SAR (interpolated) = 1.10 mW/g

Left Touch 661/Zoom Scan (5x5x7)/Cube 0: Measurement grid: dx=8mm, dy=8mm, dz=5mm

Reference Value = 14.4 V/m; Power Drift = -0.999 dB

Peak SAR (extrapolated) = 1.56 W/kg

SAR(1 g) = 0.925 mW/g; SAR(10 g) = 0.516 mW/g

Maximum value of SAR (measured) = 1.03 mW/g

Left Touch 661/Zoom Scan (5x5x7)/Cube 1: Measurement grid: dx=8mm, dy=8mm, dz=5mm

Reference Value = 14.4 V/m; Power Drift = -0.099 dB

Peak SAR (extrapolated) = 1.44 W/kg

SAR(1 g) = 0.827 mW/g; SAR(10 g) = 0.472 mW/g

Maximum value of SAR (measured) = 0.972 mW/g

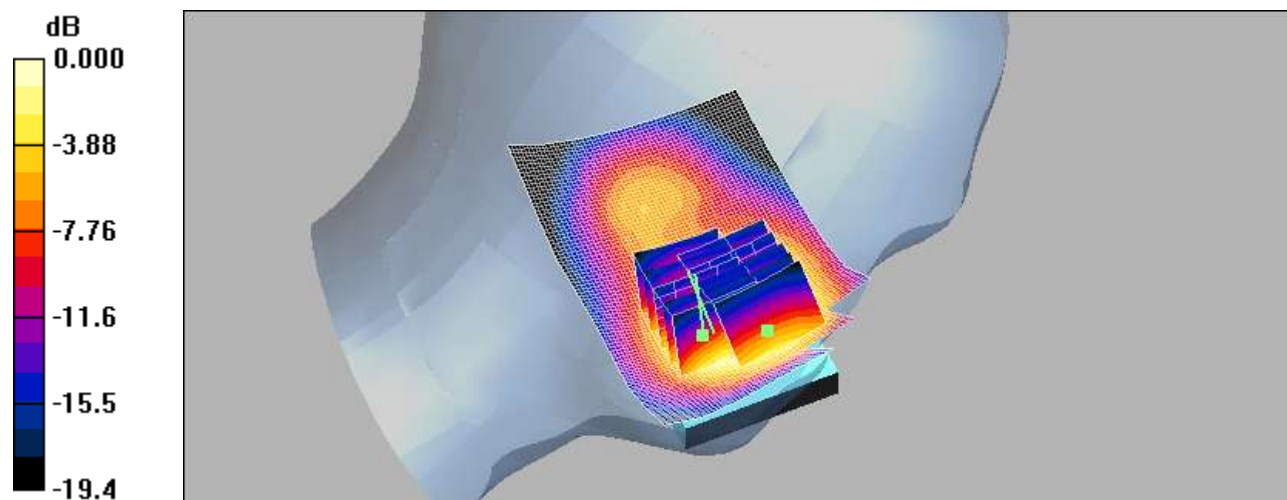

0 dB = 0.972mW/g

Test Laboratory: HCT CO., LTD
EUT Type: 850/1900 GSM/GPRS Phone with Bluetooth v3.0 and EDGE Rx only
Liquid Temperature: 21.3 °C
Ambient Temperature: 21.5 °C
Test Date: Jan. 14, 2013

DUT: GT-S3802; Type: bar; Serial: FK-008-A

Communication System: GSM 850; Frequency: 836.6 MHz; Duty Cycle: 1:8.3
Medium parameters used (interpolated): $f = 836.6$ MHz; $\sigma = 0.92$ mho/m; $\epsilon_r = 40.4$; $\rho = 1000$ kg/m³
Phantom section: Left Section ; Measurement SW: DASY4, V4.7 Build 71; Postprocessing SW: SEMCAD, V1.8 Build 184

DASY4 Configuration:

- Probe: ET3DV6 - SN1605; ConvF(6.64, 6.64, 6.64); Calibrated: 2012-04-26
- Sensor-Surface: 4mm (Mechanical Surface Detection)
- Electronics: DAE4 Sn869; Calibrated: 2012-09-18
- Phantom: SAM 835/900 MHz; Type: SAM

Left Touch 190/Area Scan (61x91x1): Measurement grid: dx=15mm, dy=15mm
Maximum value of SAR (interpolated) = 0.494 mW/g

Left Touch 190/Zoom Scan (5x5x7)/Cube 0: Measurement grid: dx=8mm, dy=8mm, dz=5mm
Reference Value = 6.02 V/m; Power Drift = -0.032 dB
Peak SAR (extrapolated) = 0.744 W/kg
SAR(1 g) = 0.484 mW/g; SAR(10 g) = 0.312 mW/g

Maximum value of SAR (measured) = 0.512 mW/g

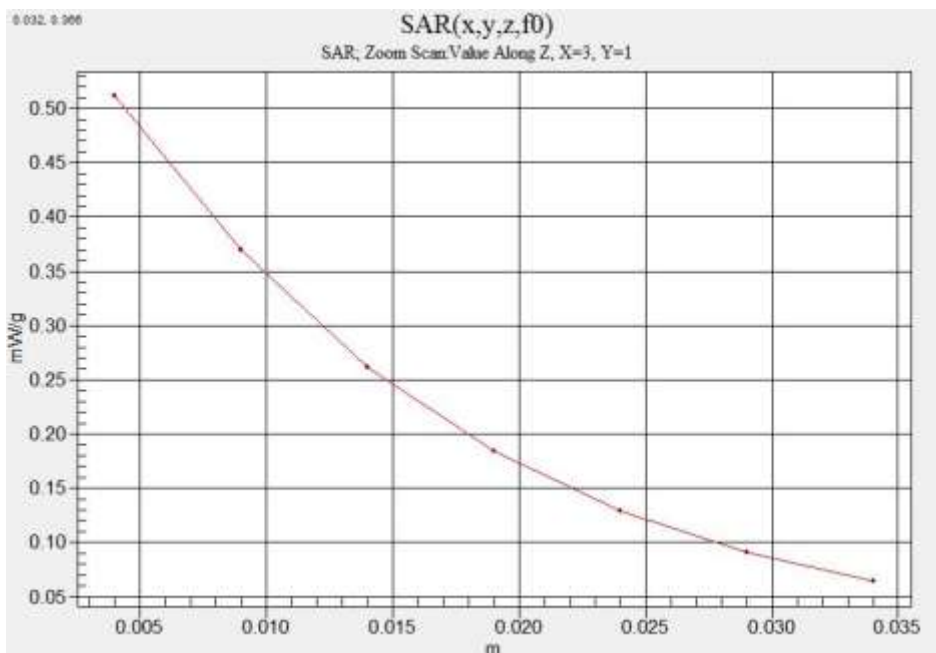

Test Laboratory: HCT CO., LTD
EUT Type: 850/1900 GSM/GPRS Phone with Bluetooth v3.0 and EDGE Rx only
Liquid Temperature: 21.3 °C
Ambient Temperature: 21.5 °C
Test Date: Jan. 14, 2013

DUT: GT-S3802; Type: bar; Serial: FK-008-A

Communication System: GSM 850; Frequency: 836.6 MHz; Duty Cycle: 1:8.3
Medium parameters used (interpolated): $f = 836.6$ MHz; $\sigma = 0.986$ mho/m; $\epsilon_r = 57.1$; $\rho = 1000$ kg/m³
Phantom section: Center Section ; Measurement SW: DASY4, V4.7 Build 71; Postprocessing SW: SEMCAD, V1.8 Build 184

DASY4 Configuration:

- Probe: ET3DV6 - SN1605; ConvF(6.52, 6.52, 6.52); Calibrated: 2012-04-26
- Sensor-Surface: 4mm (Mechanical Surface Detection)
- Electronics: DAE4 Sn869; Calibrated: 2012-09-18
- Phantom: Triple Flat Phantom 5.1C; Type: QD 000 P51 CA

Rear 190/Area Scan (61x91x1): Measurement grid: dx=15mm, dy=15mm

Maximum value of SAR (interpolated) = 0.492 mW/g

Rear 190/Zoom Scan (5x5x7)/Cube 0: Measurement grid: dx=8mm, dy=8mm, dz=5mm

Reference Value = 5.87 V/m; Power Drift = -0.05 dB

Peak SAR (extrapolated) = 0.659 W/kg

SAR(1 g) = 0.453 mW/g; SAR(10 g) = 0.300 mW/g

Maximum value of SAR (measured) = 0.486 mW/g

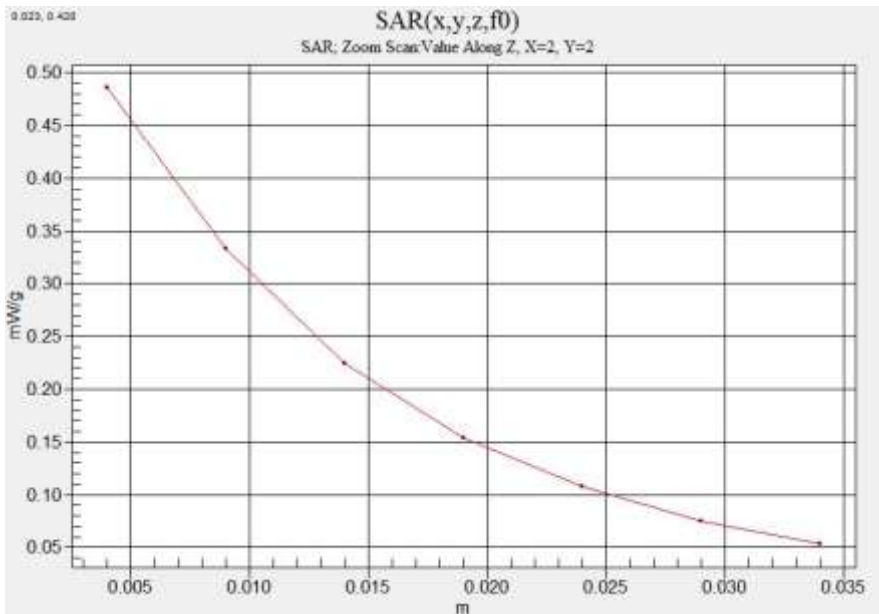

Test Laboratory: HCT CO., LTD
EUT Type: 850/1900 GSM/GPRS Phone with Bluetooth v3.0 and EDGE Rx only
Liquid Temperature: 21.2 °C
Ambient Temperature: 21.4 °C
Test Date: Jan. 15, 2013

DUT: GT-S3802; Type: bar; Serial: FK-008-A

Communication System: GSM 1900; Frequency: 1880 MHz; Duty Cycle: 1:8.3
Medium parameters used: $f = 1880$ MHz; $\sigma = 1.35$ mho/m; $\epsilon_r = 40.9$; $\rho = 1000$ kg/m³
Phantom section: Left Section ; Measurement SW: DASY4, V4.7 Build 71; Postprocessing SW: SEMCAD, V1.8 Build 184

DASY4 Configuration:

- Probe: ET3DV6 - SN1605; ConvF(5.26, 5.26, 5.26); Calibrated: 2012-04-26
- Sensor-Surface: 4mm (Mechanical Surface Detection)
- Electronics: DAE4 Sn869; Calibrated: 2012-09-18
- Phantom: SAM 1800/1900 MHz; Type: SAM

Left Touch 661/Area Scan (61x91x1): Measurement grid: dx=15mm, dy=15mm

Maximum value of SAR (interpolated) = 1.17 mW/g

Left Touch 661/Zoom Scan (5x5x7)/Cube 0: Measurement grid: dx=8mm, dy=8mm, dz=5mm

Reference Value = 11.8 V/m; Power Drift = -0.262 dB

Peak SAR (extrapolated) = 1.66 W/kg

SAR(1 g) = 0.962 mW/g; SAR(10 g) = 0.529 mW/g

Maximum value of SAR (measured) = 1.08 mW/g

Left Touch 661/Zoom Scan (5x5x7)/Cube 1: Measurement grid: dx=8mm, dy=8mm, dz=5mm

Reference Value = 11.8 V/m; Power Drift = -0.062 dB

Peak SAR (extrapolated) = 1.46 W/kg

SAR(1 g) = 0.813 mW/g; SAR(10 g) = 0.457 mW/g

Maximum value of SAR (measured) = 0.998 mW/g

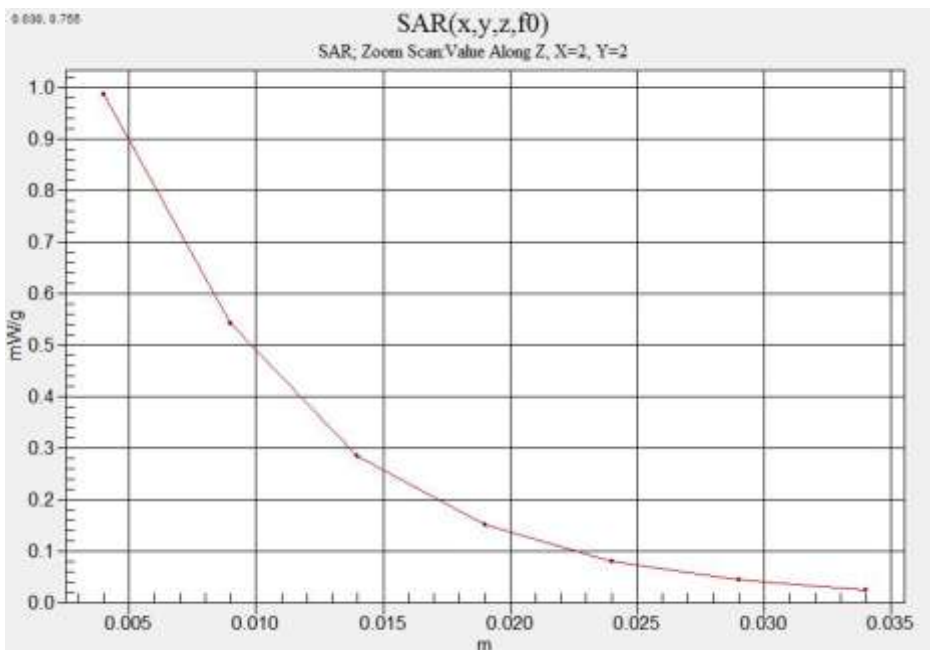

Test Laboratory: HCT CO., LTD
EUT Type: 850/1900 GSM/GPRS Phone with Bluetooth v3.0 and EDGE Rx only
Liquid Temperature: 21.2 °C
Ambient Temperature: 21.4 °C
Test Date: Jan. 15, 2013

DUT: GT-S3802; Type: bar; Serial: FK-008-A

Communication System: GSM1900; Frequency: 1880 MHz; Duty Cycle: 1:8.3
Medium parameters used: $f = 1880$ MHz; $\sigma = 1.53$ mho/m; $\epsilon_r = 52.1$; $\rho = 1000$ kg/m³
Phantom section: Center Section ; Measurement SW: DASY4, V4.7 Build 71; Postprocessing SW: SEMCAD, V1.8 Build 184

DASY4 Configuration:

- Probe: ET3DV6 - SN1605; ConvF(4.64, 4.64, 4.64); Calibrated: 2012-04-26
- Sensor-Surface: 4mm (Mechanical Surface Detection)
- Electronics: DAE4 Sn869; Calibrated: 2012-09-18
- Phantom: Triple Flat Phantom 5.1C; Type: QD 000 P51 CA

Front 661/Area Scan (61x91x1): Measurement grid: dx=15mm, dy=15mm
Maximum value of SAR (interpolated) = 0.558 mW/g

Front 661/Zoom Scan (5x5x7)/Cube 0: Measurement grid: dx=8mm, dy=8mm, dz=5mm
Reference Value = 12.3 V/m; Power Drift = 0.07 dB
Peak SAR (extrapolated) = 0.790 W/kg
SAR(1 g) = 0.492 mW/g; SAR(10 g) = 0.296 mW/g
Maximum value of SAR (measured) = 0.532 mW/g

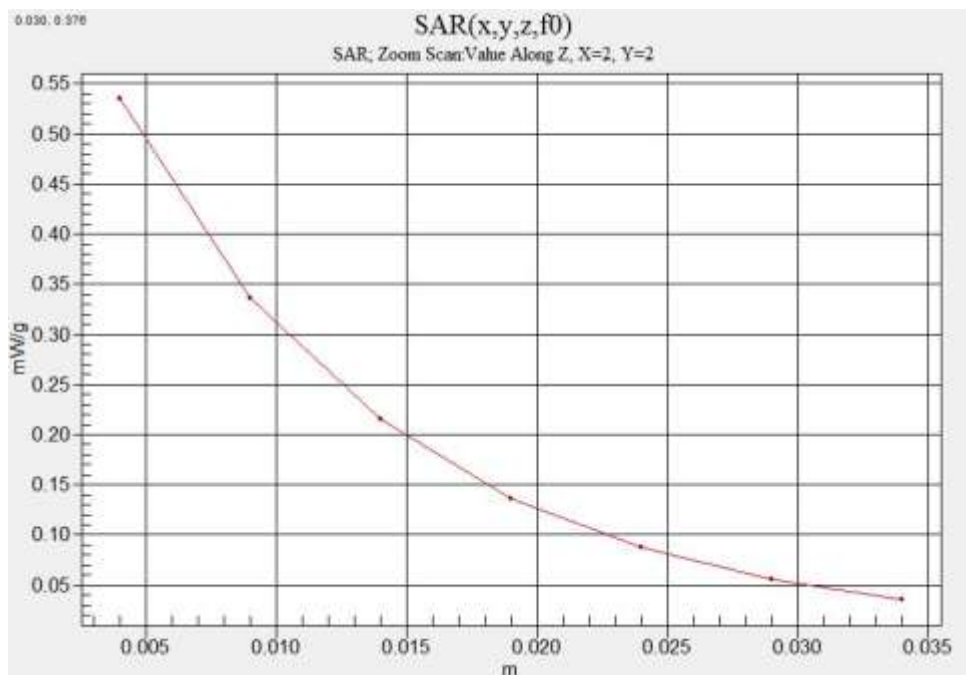

Attachment 2. – Dipole Validation Plots

Validation Data (835 MHz Head)

Test Laboratory: HCT CO., LTD
Input Power: 100 mW (20 dBm)
Liquid Temp: 21.3 °C
Test Date: Jan. 14, 2013

DUT: Dipole 835 MHz; Type: D835V2; Serial: D835V2 – SN:441

Communication System: CW; Frequency: 835 MHz; Duty Cycle: 1:1
Medium parameters used: $f = 835 \text{ MHz}$; $\sigma = 0.918 \text{ mho/m}$; $\epsilon_r = 40.4$; $\rho = 1000 \text{ kg/m}^3$
Phantom section: Flat Section ; Measurement SW: DASY4, V4.7 Build 71; Postprocessing SW: SEMCAD, V1.8 Build 184

DASY4 Configuration:

- Probe: ET3DV6 – SN1605; ConvF(6.64, 6.64, 6.64); Calibrated: 2012-04-26
- Sensor-Surface: 4mm (Mechanical Surface Detection)
- Electronics: DAE4 Sn869; Calibrated: 2012-09-18
- Phantom: SAM 1800/1900 MHz; Type: SAM

Validation 835MHz/Area Scan (61x61x1): Measurement grid: $dx=15\text{mm}$, $dy=15\text{mm}$
Maximum value of SAR (interpolated) = 1.04 mW/g

Validation 835MHz/Zoom Scan (5x5x7)/Cube 0: Measurement grid: $dx=8\text{mm}$, $dy=8\text{mm}$, $dz=5\text{mm}$
Reference Value = 34.7 V/m; Power Drift = -0.002 dB
Peak SAR (extrapolated) = 1.48 W/kg
SAR(1 g) = 0.961 mW/g; SAR(10 g) = 0.613 mW/g
Maximum value of SAR (measured) = 1.05 mW/g

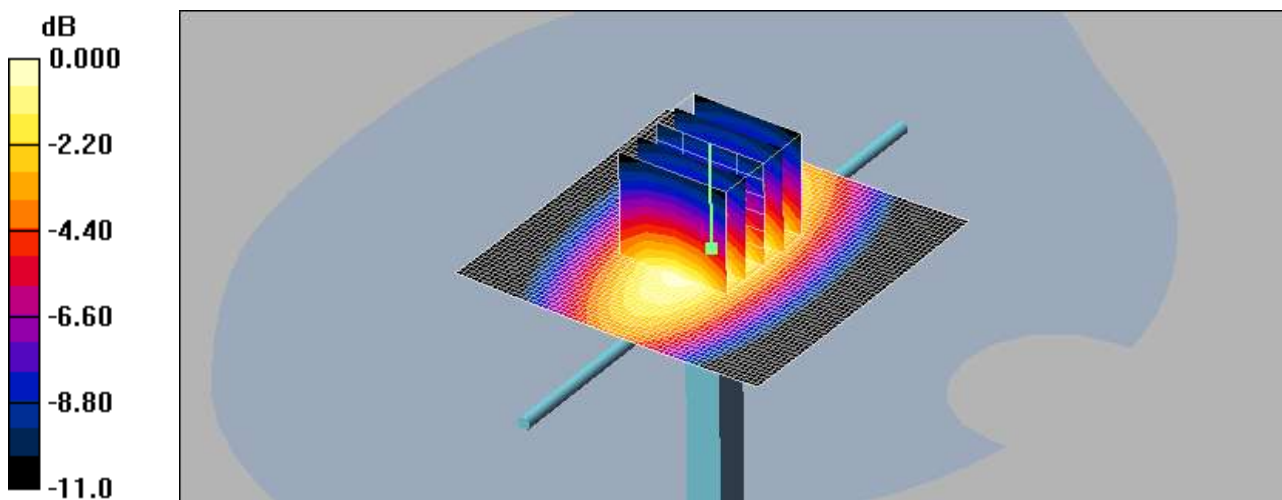

0 dB = 1.05mW/g

Validation Data (835 MHz Body)

Test Laboratory: HCT CO., LTD
Input Power: 100 mW (20 dBm)
Liquid Temp: 21.3 °C
Test Date: Jan. 14, 2013

DUT: Dipole 835 MHz; Type: D835V2; Serial: D835V2- SN:441

Communication System: CW; Frequency: 835 MHz; Duty Cycle: 1:1
Medium parameters used: $f = 835 \text{ MHz}$; $\sigma = 0.984 \text{ mho/m}$; $\epsilon_r = 57.1$; $\rho = 1000 \text{ kg/m}^3$
Phantom section: Center Section ; Measurement SW: DASY4, V4.7 Build 71; Postprocessing SW: SEMCAD, V1.8 Build 184

DASY4 Configuration:

- Probe: ET3DV6 - SN1605; ConvF(6.52, 6.52, 6.52); Calibrated: 2012-04-26
- Sensor-Surface: 4mm (Mechanical Surface Detection)
- Electronics: DAE4 Sn869; Calibrated: 2012-09-18
- Phantom: Triple Flat Phantom 5.1C; Type: QD 000 P51 CA

Validation 835 MHz/Area Scan (111x61x1): Measurement grid: $dx=15\text{mm}$, $dy=15\text{mm}$
Maximum value of SAR (interpolated) = 1.03 mW/g

Validation 835 MHz/Zoom Scan (5x5x7)/Cube 0: Measurement grid: $dx=8\text{mm}$, $dy=8\text{mm}$, $dz=5\text{mm}$
Reference Value = 33.6 V/m; Power Drift = 0.080 dB
Peak SAR (extrapolated) = 1.40 W/kg
SAR(1 g) = 0.957 mW/g; SAR(10 g) = 0.622 mW/g
Maximum value of SAR (measured) = 1.04 mW/g

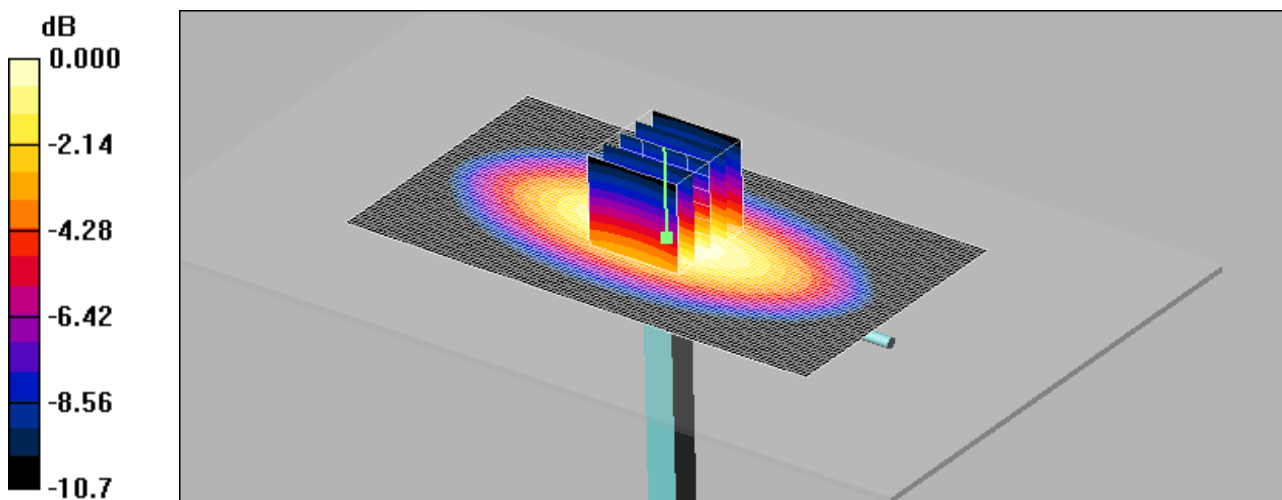

0 dB = 1.04mW/g

Validation Data (1 900 MHz Head)

Test Laboratory: HCT CO., LTD
Input Power: 100 mW (20 dBm)
Liquid Temp: 21.2 °C
Test Date: Jan. 15, 2013

DUT: Dipole 1900 MHz; Type: D1900V2; Serial: D1900V2 – SN:5d032

Communication System: CW; Frequency: 1900 MHz; Duty Cycle: 1:1
Medium parameters used: $f = 1900$ MHz; $\sigma = 1.37$ mho/m; $\epsilon_r = 40.9$; $\rho = 1000$ kg/m³
Phantom section: Flat Section ; Measurement SW: DASY4, V4.7 Build 71; Postprocessing SW: SEMCAD, V1.8 Build 184

DASY4 Configuration:

- Probe: ET3DV6 – SN1605; ConvF(5.26, 5.26, 5.26); Calibrated: 2012-04-26
- Sensor-Surface: 4mm (Mechanical Surface Detection)
- Electronics: DAE4 Sn869; Calibrated: 2012-09-18
- Phantom: SAM 835/900 MHz; Type: SAM

Dipole 1900MHz Validation/Area Scan (61x61x1): Measurement grid: dx=15mm, dy=15mm
Maximum value of SAR (interpolated) = 4.28 mW/g

Dipole 1900MHz Validation/Zoom Scan (5x5x7)/Cube 0: Measurement grid: dx=8mm, dy=8mm, dz=5mm
Reference Value = 58.3 V/m; Power Drift = -0.004 dB
Peak SAR (extrapolated) = 6.54 W/kg
SAR(1 g) = 3.85 mW/g; SAR(10 g) = 2.15 mW/g

Maximum value of SAR (measured) = 4.25 mW/g

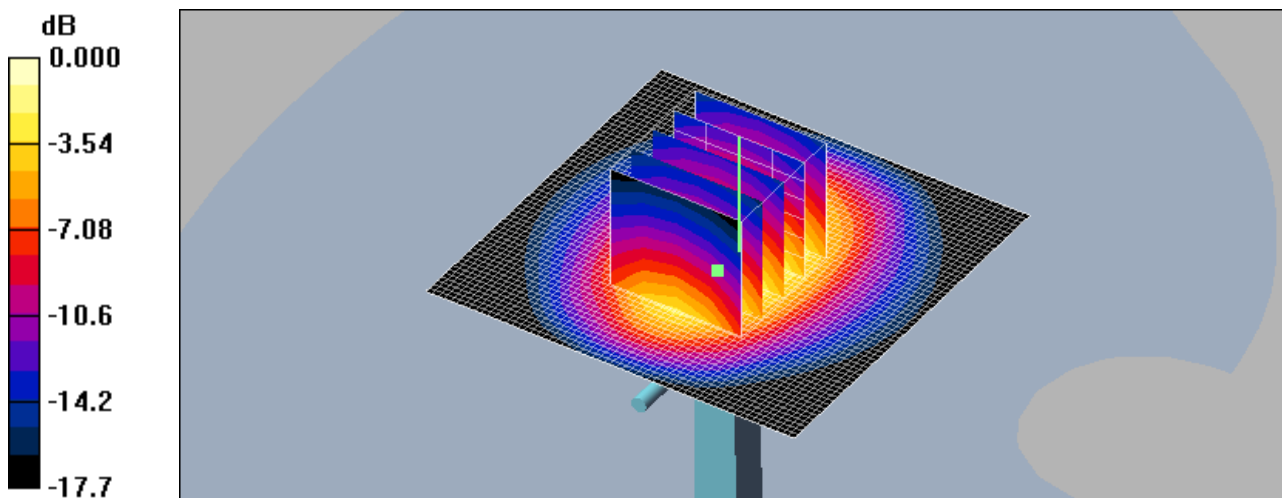

0 dB = 4.25mW/g

Validation Data (1 900 MHz Body)

Test Laboratory: HCT CO., LTD
Input Power: 100 mW (20 dBm)
Liquid Temp: 21.2 °C
Test Date: Jan. 15, 2013

DUT: Dipole 1900 MHz; Type: D1900V2; Serial: D1900V2 – SN:5d032

Communication System: CW; Frequency: 1900 MHz; Duty Cycle: 1:1
Medium parameters used: $f = 1900$ MHz; $\sigma = 1.55$ mho/m; $\epsilon_r = 52$; $\rho = 1000$ kg/m³
Phantom section: Center Section ; Measurement SW: DASY4, V4.7 Build 71; Postprocessing SW: SEMCAD, V1.8 Build 184

DASY4 Configuration:

- Probe: ET3DV6 – SN1605; ConvF(4.64, 4.64, 4.64); Calibrated: 2012-04-26
- Sensor-Surface: 4mm (Mechanical Surface Detection)
- Electronics: DAE4 Sn869; Calibrated: 2012-09-18
- Phantom: Triple Flat Phantom 5.1C_20120905; Type: QD 000 P51 CA

Validation 1900 MHz/Area Scan (61x61x1): Measurement grid: dx=15mm, dy=15mm
Maximum value of SAR (interpolated) = 4.57 mW/g

Validation 1900 MHz/Zoom Scan (5x5x7)/Cube 0: Measurement grid: dx=8mm, dy=8mm, dz=5mm
Reference Value = 56.3 V/m; Power Drift = -0.053 dB
Peak SAR (extrapolated) = 6.55 W/kg
SAR(1 g) = 3.89 mW/g; SAR(10 g) = 2.1 mW/g
Maximum value of SAR (measured) = 4.30 mW/g

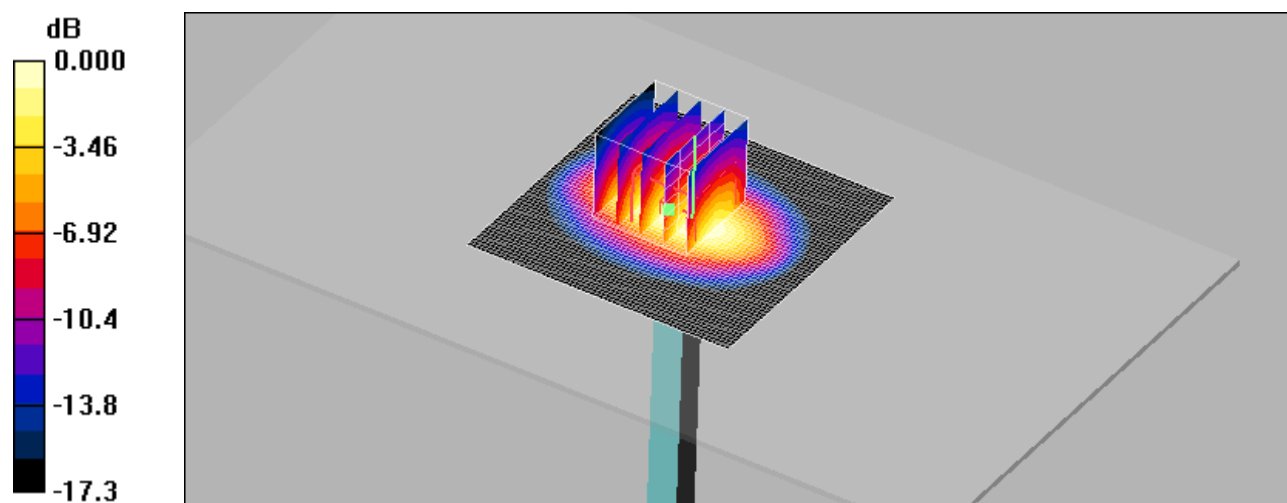

0 dB = 4.30mW/g

■ Dielectric Parameter (835 MHz Head)

Title GT-S3802
 SubTitle 835MHz
 Test Date Jan. 14, 2013

| Frequency | e' | e'' |
|----------------|---------|---------|
| 800000000.0000 | 40.7534 | 19.9096 |
| 805000000.0000 | 40.6662 | 19.8824 |
| 810000000.0000 | 40.6488 | 19.8697 |
| 815000000.0000 | 40.5945 | 19.8775 |
| 820000000.0000 | 40.5531 | 19.8500 |
| 825000000.0000 | 40.5089 | 19.8289 |
| 830000000.0000 | 40.4802 | 19.8038 |
| 835000000.0000 | 40.4433 | 19.7655 |
| 840000000.0000 | 40.3951 | 19.7411 |
| 845000000.0000 | 40.3671 | 19.7115 |
| 850000000.0000 | 40.2846 | 19.7077 |
| 855000000.0000 | 40.2405 | 19.6522 |
| 860000000.0000 | 40.1955 | 19.6284 |
| 865000000.0000 | 40.1176 | 19.5936 |
| 870000000.0000 | 40.1034 | 19.5467 |
| 875000000.0000 | 40.0151 | 19.5413 |
| 880000000.0000 | 39.9407 | 19.5273 |
| 885000000.0000 | 39.8799 | 19.5048 |
| 890000000.0000 | 39.8010 | 19.4679 |
| 895000000.0000 | 39.7709 | 19.4424 |
| 900000000.0000 | 39.7114 | 19.4157 |

■ Dielectric Parameter (835 MHz Body)

Title GT-S3802
SubTitle 835MHz
Test Date Jan. 14, 2013

| Frequency | e' | e'' |
|-----------------------|----------------|----------------|
| 800000000.0000 | 57.4718 | 21.5681 |
| 805000000.0000 | 57.4067 | 21.5412 |
| 810000000.0000 | 57.3752 | 21.4792 |
| 815000000.0000 | 57.3244 | 21.3795 |
| 820000000.0000 | 57.2515 | 21.3684 |
| 825000000.0000 | 57.1953 | 21.2949 |
| 830000000.0000 | 57.1613 | 21.2472 |
| 835000000.0000 | 57.1010 | 21.1878 |
| 840000000.0000 | 57.0724 | 21.1499 |
| 845000000.0000 | 57.0150 | 21.1070 |
| 850000000.0000 | 56.9669 | 21.0994 |
| 855000000.0000 | 56.9000 | 21.1104 |
| 860000000.0000 | 56.8806 | 21.0862 |
| 865000000.0000 | 56.8656 | 21.0983 |
| 870000000.0000 | 56.7973 | 21.1099 |
| 875000000.0000 | 56.7862 | 21.1525 |
| 880000000.0000 | 56.7496 | 21.1297 |
| 885000000.0000 | 56.6901 | 21.1271 |
| 890000000.0000 | 56.6779 | 21.1585 |
| 895000000.0000 | 56.6614 | 21.1383 |
| 900000000.0000 | 56.6365 | 21.1215 |

■ Dielectric Parameter (1 900 MHz Head)

Title GT-S3802
SubTitle 1 900MHz
Test Date Jan. 15, 2013

| Frequency | e' | e'' |
|-----------------|---------|---------|
| 1800000000.0000 | 41.2161 | 12.6665 |
| 1810000000.0000 | 41.1712 | 12.6912 |
| 1820000000.0000 | 41.1305 | 12.7183 |
| 1830000000.0000 | 41.0923 | 12.7492 |
| 1840000000.0000 | 41.0452 | 12.7750 |
| 1850000000.0000 | 41.0209 | 12.8135 |
| 1860000000.0000 | 40.9849 | 12.8499 |
| 1870000000.0000 | 40.9500 | 12.8857 |
| 1880000000.0000 | 40.9076 | 12.9122 |
| 1890000000.0000 | 40.8808 | 12.9468 |
| 1900000000.0000 | 40.8579 | 12.9607 |
| 1910000000.0000 | 40.8047 | 12.9858 |
| 1920000000.0000 | 40.7598 | 13.0146 |
| 1930000000.0000 | 40.7161 | 13.0458 |
| 1940000000.0000 | 40.6950 | 13.0833 |
| 1950000000.0000 | 40.6579 | 13.1148 |
| 1960000000.0000 | 40.6188 | 13.1374 |
| 1970000000.0000 | 40.5867 | 13.1650 |
| 1980000000.0000 | 40.5513 | 13.1909 |
| 1990000000.0000 | 40.5110 | 13.2024 |
| 2000000000.0000 | 40.4643 | 13.2446 |

■ Dielectric Parameter (1 900 MHz Body)

Title GT-S3802
SubTitle 1 900MHz
Test Date Jan. 15, 2013

| Frequency | e' | e'' |
|-----------------|---------|---------|
| 1850000000.0000 | 52.1244 | 14.5562 |
| 1855000000.0000 | 52.1140 | 14.5646 |
| 1860000000.0000 | 52.0923 | 14.5813 |
| 1865000000.0000 | 52.0826 | 14.5894 |
| 1870000000.0000 | 52.0633 | 14.5957 |
| 1875000000.0000 | 52.0606 | 14.6022 |
| 1880000000.0000 | 52.0594 | 14.6148 |
| 1885000000.0000 | 52.0460 | 14.6294 |
| 1890000000.0000 | 52.0421 | 14.6227 |
| 1895000000.0000 | 52.0151 | 14.6298 |
| 1900000000.0000 | 51.9946 | 14.6436 |
| 1905000000.0000 | 51.9863 | 14.6600 |
| 1910000000.0000 | 51.9611 | 14.6616 |
| 1915000000.0000 | 51.9699 | 14.6696 |
| 1920000000.0000 | 51.9323 | 14.6702 |
| 1925000000.0000 | 51.9086 | 14.6987 |
| 1930000000.0000 | 51.8972 | 14.7054 |
| 1935000000.0000 | 51.8849 | 14.7218 |
| 1940000000.0000 | 51.8816 | 14.7331 |
| 1945000000.0000 | 51.8452 | 14.7379 |
| 1950000000.0000 | 51.8464 | 14.7351 |

Attachment 3. – Probe Calibration Data

**Calibration Laboratory of
Schmid & Partner
Engineering AG**
Zeughausstrasse 43, 8004 Zurich, Switzerland



S Schweizerischer Kalibrierdienst
C Service suisse d'étalonnage
S Servizio svizzero di taratura
S Swiss Calibration Service

Accredited by the Swiss Accreditation Service (SAS)
The Swiss Accreditation Service is one of the signatories to the EA
Multilateral Agreement for the recognition of calibration certificates

Accreditation No.: **SCS 108**

Client: **HCT (Dymstec)**

Certificate No: **ET3-1605_Apr12**

CALIBRATION CERTIFICATE

Object: **ET3DV6 - SN:1605**

Calibration procedure(s): **QA CAL-01.v8, QA CAL-23.v4, QA CAL-25.v4
Calibration procedure for dosimetric E-field probes**

Calibration date: **April 26, 2012**

This calibration certificate documents the traceability to national standards, which realize the physical units of measurements (SI).
The measurements and the uncertainties with confidence probability are given on the following pages and are part of the certificate.

All calibrations have been conducted in the closed laboratory facility: environment temperature (22 ± 3)°C and humidity < 70%.

Calibration Equipment used (M&TE critical for calibration)

| Primary Standards | ID | Cal Date (Certificate No.) | Scheduled Calibration |
|----------------------------|-----------------|-----------------------------------|------------------------|
| Power meter E4419B | GB41293874 | 29-Mar-12 (No. 217-01508) | Apr-13 |
| Power sensor E4412A | MY41498087 | 29-Mar-12 (No. 217-01508) | Apr-13 |
| Reference 3 dB Attenuator | SN: 55054 (3c) | 27-Mar-12 (No. 217-01531) | Apr-13 |
| Reference 20 dB Attenuator | SN: 55086 (20b) | 27-Mar-12 (No. 217-01529) | Apr-13 |
| Reference 30 dB Attenuator | SN: 95129 (30m) | 27-Mar-12 (No. 217-01532) | Apr-13 |
| Reference Probe ES3DV2 | SN: 3013 | 29-Dec-11 (No. ES3-3013, Dec11) | Dec-12 |
| DAE4 | SN: 660 | 10-Jan-12 (No. DAE4-660, Jan12) | Jan-13 |
| Secondary Standards | ID | Check Date (in house) | Scheduled Check |
| RF generator HP 8648C | US3642U01700 | 4-Aug-99 (in house check Apr-11) | in house check: Apr-13 |
| Network Analyzer HP 8753E | US37390585 | 18-Oct-01 (in house check Oct-11) | in house check: Oct-12 |

| | Name | Function | Signature |
|----------------|---------------|-----------------------|-----------|
| Calibrated by: | Jeton Kasrafi | Laboratory Technician | |
| Approved by: | Katja Pokovic | Technical Manager | |

Issued: April 26, 2012

This calibration certificate shall not be reproduced except in full without written approval of the laboratory.

**Calibration Laboratory of
Schmid & Partner
Engineering AG**
Zeughausstrasse 43, 8004 Zurich, Switzerland



S Schweizerischer Kalibrierdienst
C Service suisse d'étalonnage
S Servizio svizzero di taratura
Swiss Calibration Service

Accredited by the Swiss Accreditation Service (SAS)
The Swiss Accreditation Service is one of the signatories to the EA
Multilateral Agreement for the recognition of calibration certificates

Accreditation No.: **SCS 108**

Glossary:

| | |
|-----------------------|---|
| TSL | tissue simulating liquid |
| NORM _{x,y,z} | sensitivity in free space |
| ConvF | sensitivity in TSL / NORM _{x,y,z} |
| DCP | diode compression point |
| CF | crest factor (1/duty_cycle) of the RF signal |
| A, B, C | modulation dependent linearization parameters |
| Polarization φ | φ rotation around probe axis |
| Polarization β | β rotation around an axis that is in the plane normal to probe axis (at measurement center), i.e., β = 0 is normal to probe axis |

Calibration is Performed According to the Following Standards:

- a) IEEE Std 1528-2003, "IEEE Recommended Practice for Determining the Peak Spatial-Averaged Specific Absorption Rate (SAR) in the Human Head from Wireless Communications Devices: Measurement Techniques", December 2003
- b) IEC 62209-1, "Procedure to measure the Specific Absorption Rate (SAR) for hand-held devices used in close proximity to the ear (frequency range of 300 MHz to 3 GHz)", February 2005

Methods Applied and Interpretation of Parameters:

- NORM_{x,y,z}: Assessed for E-field polarization β = 0 (f ≤ 900 MHz in TEM-cell; f > 1800 MHz: R22 waveguide). NORM_{x,y,z} are only intermediate values, i.e., the uncertainties of NORM_{x,y,z} does not affect the E²-field uncertainty inside TSL (see below ConvF).
- NORM(f)_{x,y,z} = NORM_{x,y,z} * frequency_response (see Frequency Response Chart). This linearization is implemented in DASY4 software versions later than 4.2. The uncertainty of the frequency response is included in the stated uncertainty of ConvF.
- DCP_{x,y,z}: DCP are numerical linearization parameters assessed based on the data of power sweep with CW signal (no uncertainty required). DCP does not depend on frequency nor media.
- PAR: PAR is the Peak to Average Ratio that is not calibrated but determined based on the signal characteristics
- A_{x,y,z}; B_{x,y,z}; C_{x,y,z}; VR_{x,y,z}: A, B, C are numerical linearization parameters assessed based on the data of power sweep for specific modulation signal. The parameters do not depend on frequency nor media. VR is the maximum calibration range expressed in RMS voltage across the diode.
- ConvF and Boundary Effect Parameters: Assessed in flat phantom using E-field (or Temperature Transfer Standard for f ≤ 800 MHz) and inside waveguide using analytical field distributions based on power measurements for f > 800 MHz. The same setups are used for assessment of the parameters applied for boundary compensation (alpha, depth) of which typical uncertainty values are given. These parameters are used in DASY4 software to improve probe accuracy close to the boundary. The sensitivity in TSL corresponds to NORM_{x,y,z} * ConvF whereby the uncertainty corresponds to that given for ConvF. A frequency dependent ConvF is used in DASY version 4.4 and higher which allows extending the validity from ± 50 MHz to ± 100 MHz.
- Spherical isotropy (3D deviation from isotropy): in a field of low gradients realized using a flat phantom exposed by a patch antenna.
- Sensor Offset: The sensor offset corresponds to the offset of virtual measurement center from the probe tip (on probe axis). No tolerance required.

ET3DV6 – SN:1605

April 26, 2012

Probe ET3DV6

SN:1605

Manufactured: July 27, 2001
Calibrated: April 26, 2012

Calibrated for DASY/EASY Systems
(Note: non-compatible with DASY2 system!)

ET3DV6- SN:1605

April 26, 2012

DASY/EASY - Parameters of Probe: ET3DV6 - SN:1605

Basic Calibration Parameters

| | Sensor X | Sensor Y | Sensor Z | Unc (k=2) |
|---|----------|----------|----------|--------------|
| Norm ($\mu\text{V}/(\text{V}/\text{m})^2$) ^A | 1.60 | 1.96 | 1.67 | $\pm 10.1\%$ |
| DCP (mV) ^B | 98.4 | 97.0 | 98.0 | |

Modulation Calibration Parameters

| UID | Communication System Name | PAR | | A dB | B dB | C dB | VR mV | Unc ^C (k=2) |
|-----|---------------------------|------|---|---------|---------|---------|----------|---------------------------|
| 0 | CW | 0.00 | X | 0.00 | 0.00 | 1.00 | 166.8 | $\pm 3.0\%$ |
| | | | Y | 0.00 | 0.00 | 1.00 | 149.9 | |
| | | | Z | 0.00 | 0.00 | 1.00 | 177.8 | |

The reported uncertainty of measurement is stated as the standard uncertainty of measurement multiplied by the coverage factor k=2, which for a normal distribution corresponds to a coverage probability of approximately 95%.

^A The uncertainties of NormX,Y,Z do not affect the E²-field uncertainty inside TSL (see Pages 5 and 6).

^B Numerical linearization parameter; uncertainty not required.

^C Uncertainty is determined using the max. deviation from linear response applying rectangular distribution and is expressed for the square of the field value.

ET3DV6- SN:1605

April 26, 2012

DASY/EASY - Parameters of Probe: ET3DV6 - SN:1605

Calibration Parameter Determined in Head Tissue Simulating Media

| f (MHz) ^c | Relative Permittivity ^d | Conductivity (S/m) ^e | ConvF X | ConvF Y | ConvF Z | Alpha | Depth (mm) | Unct. (k=2) |
|----------------------|------------------------------------|---------------------------------|---------|---------|---------|-------|------------|-------------|
| 750 | 41.9 | 0.89 | 7.03 | 7.03 | 7.03 | 0.25 | 3.00 | ± 12.0 % |
| 835 | 41.5 | 0.90 | 6.64 | 6.64 | 6.64 | 0.29 | 3.00 | ± 12.0 % |
| 900 | 41.5 | 0.97 | 6.52 | 6.52 | 6.52 | 0.23 | 3.00 | ± 12.0 % |
| 1450 | 40.5 | 1.20 | 5.73 | 5.73 | 5.73 | 0.77 | 2.20 | ± 12.0 % |
| 1750 | 40.1 | 1.37 | 5.51 | 5.51 | 5.51 | 0.80 | 1.76 | ± 12.0 % |
| 1900 | 40.0 | 1.40 | 5.26 | 5.26 | 5.26 | 0.80 | 1.91 | ± 12.0 % |
| 1950 | 40.0 | 1.40 | 5.08 | 5.08 | 5.08 | 0.80 | 1.62 | ± 12.0 % |
| 2450 | 39.2 | 1.80 | 4.59 | 4.59 | 4.59 | 0.80 | 2.02 | ± 12.0 % |

^c Frequency validity of ± 100 MHz only applies for DASY v4.4 and higher (see Page 2), else it is restricted to ± 50 MHz. The uncertainty is the RSS of the ConvF uncertainty at calibration frequency and the uncertainty for the indicated frequency band.

^d At frequencies below 3 GHz, the validity of tissue parameters (ϵ and σ) can be relaxed to ± 10% if liquid compensation formula is applied to measured SAR values. At frequencies above 3 GHz, the validity of tissue parameters (ϵ and σ) is restricted to ± 5%. The uncertainty is the RSS of the ConvF uncertainty for indicated target tissue parameters.

ET3DV6- SN:1605

April 26, 2012

DASY/EASY - Parameters of Probe: ET3DV6 - SN:1605

Calibration Parameter Determined in Body Tissue Simulating Media

| f (MHz) ^c | Relative Permittivity ^f | Conductivity (S/m) ^f | ConvF X | ConvF Y | ConvF Z | Alpha | Depth (mm) | Unct. (k=2) |
|----------------------|------------------------------------|---------------------------------|---------|---------|---------|-------|------------|-------------|
| 750 | 55.5 | 0.96 | 6.61 | 6.61 | 6.61 | 0.22 | 3.00 | ± 12.0 % |
| 835 | 55.2 | 0.97 | 6.52 | 6.52 | 6.52 | 0.28 | 3.00 | ± 12.0 % |
| 1750 | 53.4 | 1.49 | 4.87 | 4.87 | 4.87 | 0.80 | 2.51 | ± 12.0 % |
| 1900 | 53.3 | 1.52 | 4.64 | 4.64 | 4.64 | 0.78 | 2.32 | ± 12.0 % |
| 2450 | 52.7 | 1.95 | 4.07 | 4.07 | 4.07 | 0.78 | 2.18 | ± 12.0 % |

^c Frequency validity of ± 100 MHz only applies for DASY v4.4 and higher (see Page 2), else it is restricted to ± 50 MHz. The uncertainty is the RSS of the ConvF uncertainty at calibration frequency and the uncertainty for the indicated frequency band.

^f At frequencies below 3 GHz, the validity of tissue parameters (ϵ and σ) can be relaxed to ± 10% if liquid compensation formula is applied to measured SAR values. At frequencies above 3 GHz, the validity of tissue parameters (ϵ and σ) is restricted to ± 5%. The uncertainty is the RSS of the ConvF uncertainty for indicated target tissue parameters.

ET3DV6-SN:1605

April 26, 2012

Frequency Response of E-Field (TEM-Cell:ifi110 EXX, Waveguide: R22)

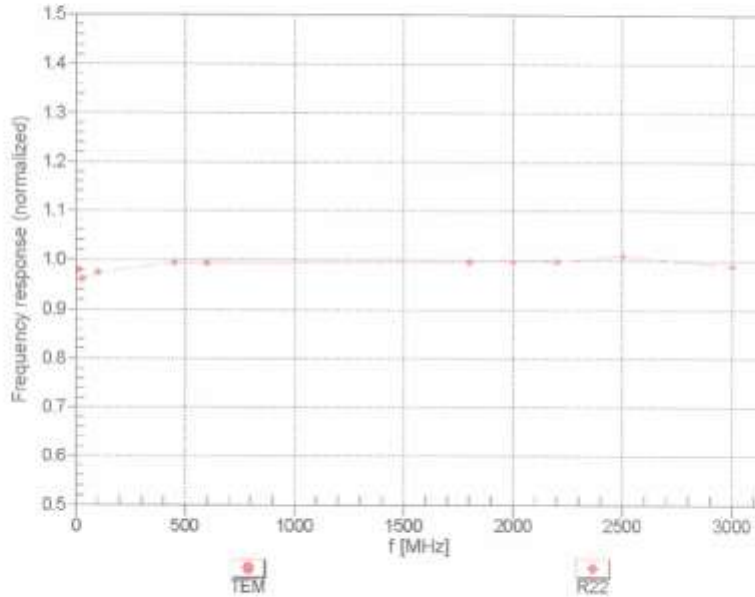

Uncertainty of Frequency Response of E-field: $\pm 6.3\%$ (k=2)

ET3DV6- SN:1605

April 26, 2012

Receiving Pattern (ϕ), $\theta = 0^\circ$

f=600 MHz,TEM

f=1800 MHz,R22

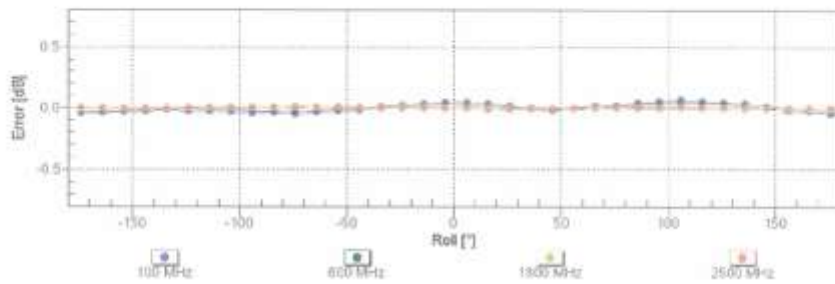
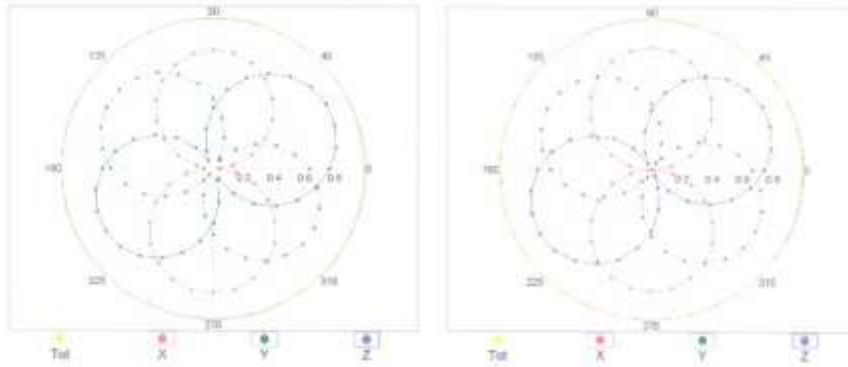

Uncertainty of Axial Isotropy Assessment: $\pm 0.5\%$ (k=2)

ET30V6-SN.1605

April 26, 2012

Dynamic Range f(SAR_{head})
(TEM cell , f = 900 MHz)

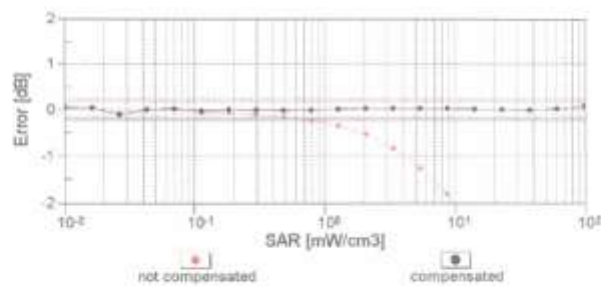
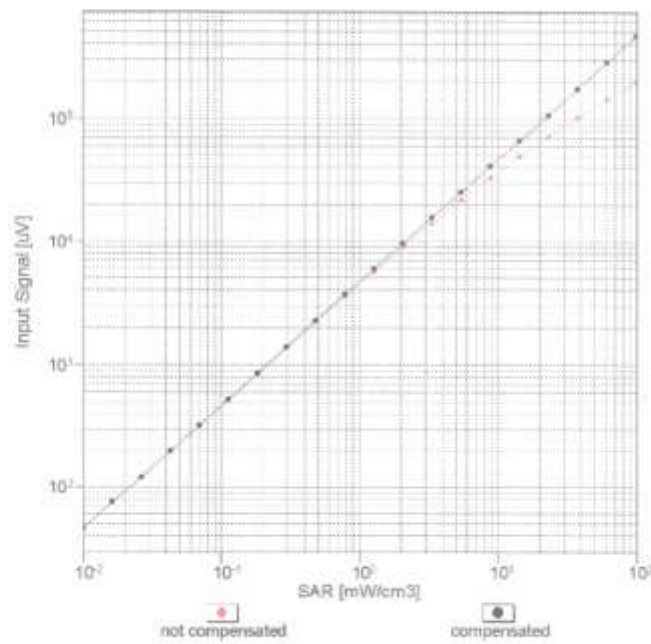

Uncertainty of Linearity Assessment: ± 0.6% (k=2)

ET3DV6- SN:1605

April 26, 2012

Conversion Factor Assessment

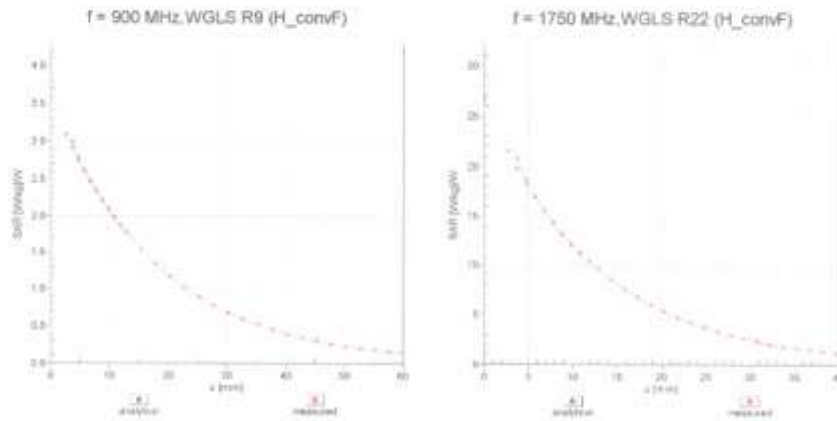

Deviation from Isotropy in Liquid

Error (ϕ , θ), $f = 900$ MHz

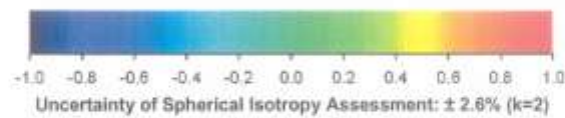
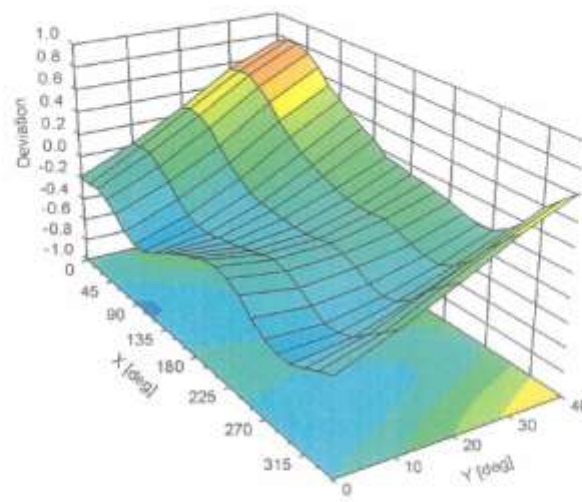

ET3DV6- SN:1605

April 26, 2012

DASY/EASY - Parameters of Probe: ET3DV6 - SN:1605**Other Probe Parameters**

| | |
|---|------------|
| Sensor Arrangement | Triangular |
| Connector Angle (°) | 56 |
| Mechanical Surface Detection Mode | enabled |
| Optical Surface Detection Mode | disabled |
| Probe Overall Length | 337 mm |
| Probe Body Diameter | 10 mm |
| Tip Length | 10 mm |
| Tip Diameter | 6.8 mm |
| Probe Tip to Sensor X Calibration Point | 2.7 mm |
| Probe Tip to Sensor Y Calibration Point | 2.7 mm |
| Probe Tip to Sensor Z Calibration Point | 2.7 mm |
| Recommended Measurement Distance from Surface | 4 mm |

Attachment 4. – Dipole Calibration Data

**Calibration Laboratory of
Schmid & Partner
Engineering AG**
Zeughausstrasse 43, 8004 Zurich, Switzerland



S Schweizerischer Kalibrierdienst
C Service suisse d'étalonnage
S Servizio svizzero di taratura
S Swiss Calibration Service

Accredited by the Swiss Accreditation Service (SAS)
The Swiss Accreditation Service is one of the signatories to the EA
Multilateral Agreement for the recognition of calibration certificates

Accreditation No.: SCS 108

Client **HCT (Dymstec)**

Certificate No: D835V2-441_May12

CALIBRATION CERTIFICATE

Object: **D835V2 - SN: 441**

Calibration procedure(s): **QA CAL-05.v8
Calibration procedure for dipole validation kits above 700 MHz**

Calibration date: **May 16, 2012**

This calibration certificate documents the traceability to national standards, which realize the physical units of measurements (SI).
The measurements and the uncertainties with confidence probability are given on the following pages and are part of the certificate.

All calibrations have been conducted in the closed laboratory facility: environment temperature (22 ± 3)°C and humidity < 70%.

Calibration Equipment used (M&TE critical for calibration)

| Primary Standards | ID # | Cal Date (Certificate No.) | Scheduled Calibration |
|-----------------------------|--------------------|-----------------------------------|------------------------|
| Power meter EPM-442A | GB37480704 | 05-Oct-11 (No. 217-01451) | Oct-12 |
| Power sensor HP 8481A | US37292783 | 05-Oct-11 (No. 217-01451) | Oct-12 |
| Reference 20 dB Attenuator | SN: 5056 (20k) | 27-Mar-12 (No. 217-01530) | Apr-13 |
| Type-N mismatch combination | SN: 5047.2 / 06327 | 27-Mar-12 (No. 217-01533) | Apr-13 |
| Reference Probe ES3DV3 | SN: 3205 | 30-Dec-11 (No. ES3-3205_Dec11) | Dec-12 |
| DAE4 | SN: 601 | 04-Jul-11 (No. DAE4-601_Jul11) | Jul-12 |
| Secondary Standards | ID # | Check Date (in house) | Scheduled Check |
| Power sensor HP 8481A | MY41092317 | 18-Oct-02 (in house check Oct-11) | in house check: Oct-13 |
| RF generator R&S SMT-06 | 100005 | 04-Aug-99 (in house check Oct-11) | in house check: Oct-13 |
| Network Analyzer HP 8753E | US37390586 S4206 | 18-Oct-01 (in house check Oct-11) | in house check: Oct-12 |

| | | | |
|----------------|----------------|-----------------------|-----------|
| | Name | Function | Signature |
| Calibrated by: | Israa El-Naouq | Laboratory Technician | |
| Approved by: | Katja Pokovic | Technical Manager | |

Issued: May 16, 2012

This calibration certificate shall not be reproduced except in full without written approval of the laboratory.

Calibration Laboratory of
Schmid & Partner
Engineering AG
Zeughausstrasse 43, 8004 Zurich, Switzerland



S Schweizerischer Kalibrierdienst
C Service suisse d'étalonnage
S Servizio svizzero di taratura
S Swiss Calibration Service

Accredited by the Swiss Accreditation Service (SAS)
The Swiss Accreditation Service is one of the signatories to the EA
Multilateral Agreement for the recognition of calibration certificates

Accreditation No.: SCS 108

Glossary:

| | |
|-------|---------------------------------|
| TSL | tissue simulating liquid |
| ConvF | sensitivity in TSL / NORM x,y,z |
| N/A | not applicable or not measured |

Calibration is Performed According to the Following Standards:

- IEEE Std 1528-2003, "IEEE Recommended Practice for Determining the Peak Spatial-Averaged Specific Absorption Rate (SAR) in the Human Head from Wireless Communications Devices: Measurement Techniques", December 2003
- IEC 62209-1, "Procedure to measure the Specific Absorption Rate (SAR) for hand-held devices used in close proximity to the ear (frequency range of 300 MHz to 3 GHz)", February 2005
- Federal Communications Commission Office of Engineering & Technology (FCC OET), "Evaluating Compliance with FCC Guidelines for Human Exposure to Radiofrequency Electromagnetic Fields; Additional Information for Evaluating Compliance of Mobile and Portable Devices with FCC Limits for Human Exposure to Radiofrequency Emissions", Supplement C (Edition 01-01) to Bulletin 65

Additional Documentation:

- DASY4/5 System Handbook

Methods Applied and Interpretation of Parameters:

- Measurement Conditions:** Further details are available from the Validation Report at the end of the certificate. All figures stated in the certificate are valid at the frequency indicated.
- Antenna Parameters with TSL:** The dipole is mounted with the spacer to position its feed point exactly below the center marking of the flat phantom section, with the arms oriented parallel to the body axis.
- Feed Point Impedance and Return Loss:** These parameters are measured with the dipole positioned under the liquid filled phantom. The impedance stated is transformed from the measurement at the SMA connector to the feed point. The Return Loss ensures low reflected power. No uncertainty required.
- Electrical Delay:** One-way delay between the SMA connector and the antenna feed point. No uncertainty required.
- SAR measured:** SAR measured at the stated antenna input power.
- SAR normalized:** SAR as measured, normalized to an input power of 1 W at the antenna connector.
- SAR for nominal TSL parameters:** The measured TSL parameters are used to calculate the nominal SAR result.

The reported uncertainty of measurement is stated as the standard uncertainty of measurement multiplied by the coverage factor $k=2$, which for a normal distribution corresponds to a coverage probability of approximately 95%.

Measurement Conditions

DASY system configuration, as far as not given on page 1.

| | | |
|------------------------------|------------------------|-------------|
| DASY Version | DASY5 | V52.8.1 |
| Extrapolation | Advanced Extrapolation | |
| Phantom | Modular Flat Phantom | |
| Distance Dipole Center - TSL | 15 mm | with Spacer |
| Zoom Scan Resolution | dx, dy, dz = 5 mm | |
| Frequency | 835 MHz \pm 1 MHz | |

Head TSL parameters

The following parameters and calculations were applied.

| | Temperature | Permittivity | Conductivity |
|---|---------------------|----------------|----------------------|
| Nominal Head TSL parameters | 22.0 °C | 41.5 | 0.90 mho/m |
| Measured Head TSL parameters | (22.0 \pm 0.2) °C | 40.6 \pm 6 % | 0.89 mho/m \pm 6 % |
| Head TSL temperature change during test | < 0.5 °C | --- | --- |

SAR result with Head TSL

| SAR averaged over 1 cm ³ (1 g) of Head TSL | Condition | |
|---|--------------------|--------------------------------|
| SAR measured | 250 mW input power | 2.35 mW / g |
| SAR for nominal Head TSL parameters | normalized to 1W | 9.43 mW / g \pm 17.0 % (k=2) |

| SAR averaged over 10 cm ³ (10 g) of Head TSL | condition | |
|---|--------------------|--------------------------------|
| SAR measured | 250 mW input power | 1.54 mW / g |
| SAR for nominal Head TSL parameters | normalized to 1W | 6.18 mW / g \pm 16.5 % (k=2) |

Body TSL parameters

The following parameters and calculations were applied.

| | Temperature | Permittivity | Conductivity |
|---|---------------------|----------------|----------------------|
| Nominal Body TSL parameters | 22.0 °C | 55.2 | 0.97 mho/m |
| Measured Body TSL parameters | (22.0 \pm 0.2) °C | 54.3 \pm 6 % | 1.00 mho/m \pm 6 % |
| Body TSL temperature change during test | < 0.5 °C | --- | --- |

SAR result with Body TSL

| SAR averaged over 1 cm ³ (1 g) of Body TSL | Condition | |
|---|--------------------|--------------------------------|
| SAR measured | 250 mW input power | 2.44 mW / g |
| SAR for nominal Body TSL parameters | normalized to 1W | 9.50 mW / g \pm 17.0 % (k=2) |

| SAR averaged over 10 cm ³ (10 g) of Body TSL | condition | |
|---|--------------------|--------------------------------|
| SAR measured | 250 mW input power | 1.60 mW / g |
| SAR for nominal Body TSL parameters | normalized to 1W | 6.27 mW / g \pm 16.5 % (k=2) |

Appendix**Antenna Parameters with Head TSL**

| | |
|--------------------------------------|--------------------------------|
| Impedance, transformed to feed point | 51.1 Ω - 5.8 j Ω |
| Return Loss | - 24.6 dB |

Antenna Parameters with Body TSL

| | |
|--------------------------------------|--------------------------------|
| Impedance, transformed to feed point | 47.0 Ω - 8.1 j Ω |
| Return Loss | - 21.0 dB |

General Antenna Parameters and Design

| | |
|----------------------------------|----------|
| Electrical Delay (one direction) | 1.372 ns |
|----------------------------------|----------|

After long term use with 100W radiated power, only a slight warming of the dipole near the feedpoint can be measured.

The dipole is made of standard semirigid coaxial cable. The center conductor of the feeding line is directly connected to the second arm of the dipole. The antenna is therefore short-circuited for DC-signals. On some of the dipoles, small end caps are added to the dipole arms in order to improve matching when loaded according to the position as explained in the "Measurement Conditions" paragraph. The SAR data are not affected by this change. The overall dipole length is still according to the Standard.

No excessive force must be applied to the dipole arms, because they might bend or the soldered connections near the feedpoint may be damaged.

Additional EUT Data

| | |
|-----------------|----------------|
| Manufactured by | SPEAG |
| Manufactured on | March 09, 2001 |

DASY5 Validation Report for Head TSL

Date: 16.05.2012

Test Laboratory: SPEAG, Zurich, Switzerland

DUT: Dipole 835 MHz; Type: D835V2; Serial: D835V2 - SN: 441

Communication System: CW; Frequency: 835 MHz

Medium parameters used: $f = 835$ MHz; $\sigma = 0.89$ mho/m; $\epsilon_r = 40.6$; $\rho = 1000$ kg/m³

Phantom section: Flat Section

Measurement Standard: DASY5 (IEEE/IEC/ANSI C63.19-2007)

DASY52 Configuration:

- Probe: ES3DV3 - SN3205; ConvF(6.07, 6.07, 6.07); Calibrated: 30.12.2011;
- Sensor-Surface: 3mm (Mechanical Surface Detection)
- Electronics: DAE4 Sn601; Calibrated: 04.07.2011
- Phantom: Flat Phantom 4.9L; Type: QD000P49AA; Serial: 1001
- DASY52 52.8.1(838); SEMCAD X 14.6.5(6469)

Dipole Calibration for Head Tissue/Pin=250 mW, d=15mm 2/Zoom Scan (7x7x7)/Cube 0:

Measurement grid: dx=5mm, dy=5mm, dz=5mm

Reference Value = 57.129 V/m; Power Drift = 0.00 dB

Peak SAR (extrapolated) = 3.474 mW/g

SAR(1 g) = 2.35 mW/g; SAR(10 g) = 1.54 mW/g

Maximum value of SAR (measured) = 2.73 mW/g

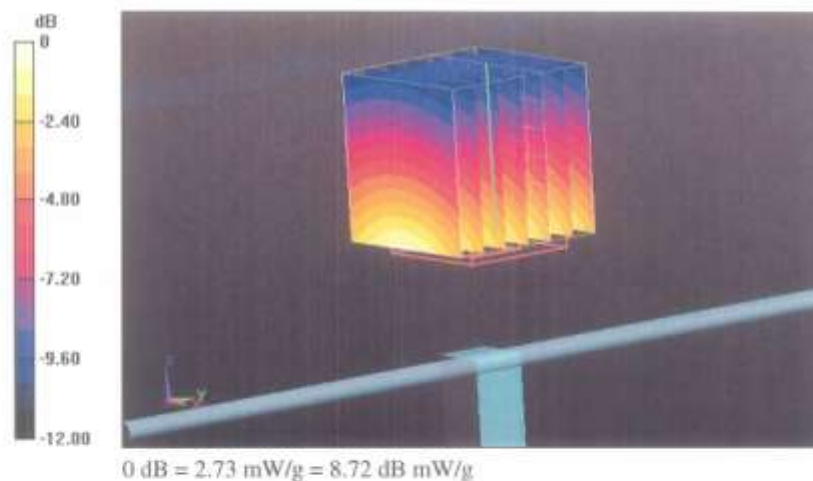

Impedance Measurement Plot for Head TSL

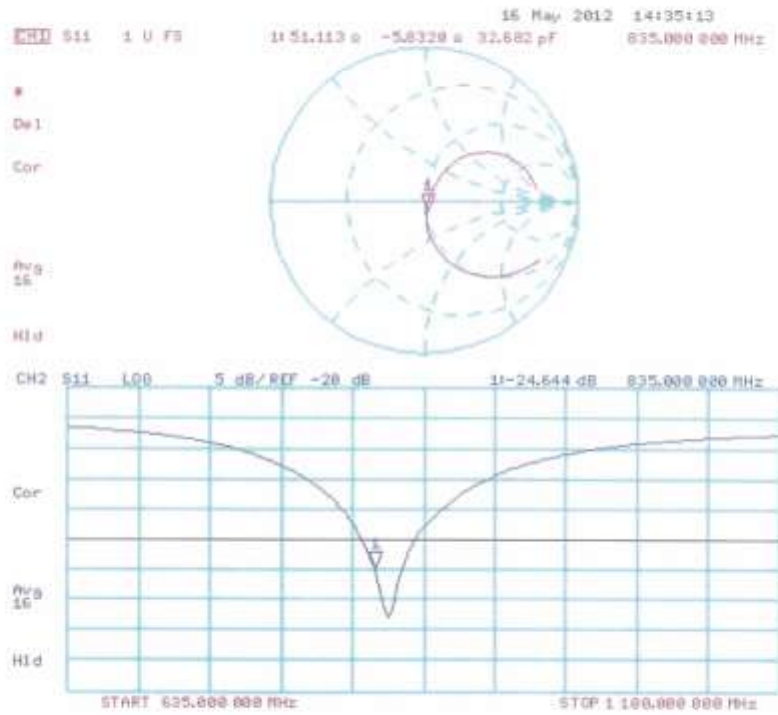

DASY5 Validation Report for Body TSL

Date: 16.05.2012

Test Laboratory: SPEAG, Zurich, Switzerland

DUT: Dipole 835 MHz; Type: D835V2; Serial: D835V2 - SN: 441

Communication System: CW; Frequency: 835 MHz

Medium parameters used: $f = 835$ MHz; $\sigma = 1$ mho/m; $\epsilon_r = 54.3$; $\rho = 1000$ kg/m³

Phantom section: Flat Section

Measurement Standard: DASY5 (IEEE/IEC/ANSI C63.19-2007)

DASY52 Configuration:

- Probe: ES3DV3 - SN3205; ConvF(6.02, 6.02, 6.02); Calibrated: 30.12.2011;
- Sensor-Surface: 3mm (Mechanical Surface Detection)
- Electronics: DAE4 Sn601; Calibrated: 04.07.2011
- Phantom: Flat Phantom 4.9L; Type: QD000P49AA; Serial: 1001
- DASY52 52.8.1(838); SEMCAD X 14.6.5(6469)

Dipole Calibration for Body Tissue/Pin=250 mW, d=15mm/Zoom Scan (7x7x7)/Cube 0:

Measurement grid: dx=5mm, dy=5mm, dz=5mm

Reference Value = 55.054 V/m; Power Drift = 0.03 dB

Peak SAR (extrapolated) = 3.533 mW/g

SAR(1 g) = 2.44 mW/g; SAR(10 g) = 1.6 mW/g

Maximum value of SAR (measured) = 2.82 mW/g

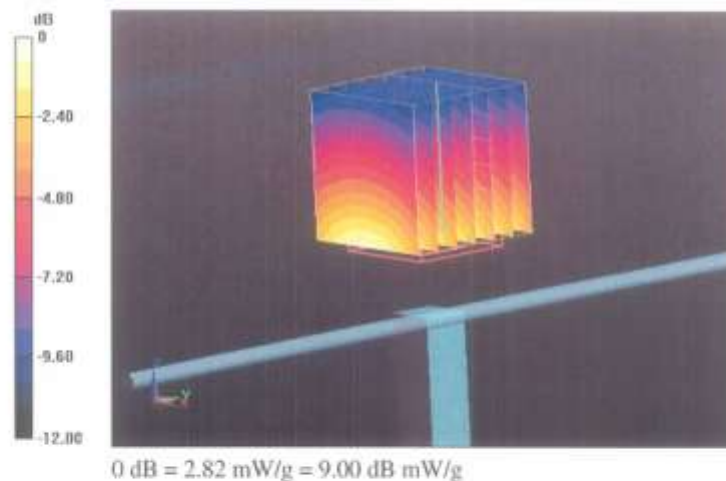

Impedance Measurement Plot for Body TSL

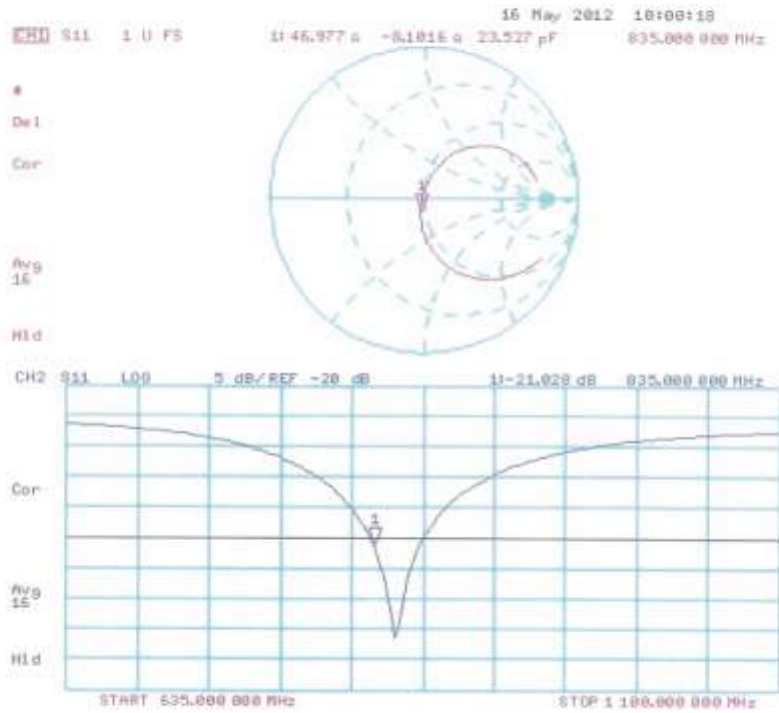

**Calibration Laboratory of
Schmid & Partner
Engineering AG**
Zeughausstrasse 43, 8004 Zurich, Switzerland



S Schweizerischer Kalibrierdienst
C Service suisse d'étalonnage
S Servizio svizzero di taratura
S Swiss Calibration Service

Accredited by the Swiss Accreditation Service (SAS)
The Swiss Accreditation Service is one of the signatories to the EA
Multilateral Agreement for the recognition of calibration certificates

Accreditation No.: **SCS 108**

Client **HCT (Dymstec)**

Certificate No: **D1900V2-5d032_Jul12**

CALIBRATION CERTIFICATE

Object: **D1900V2 - SN: 5d032**

Calibration procedure(s): **QA CAL-05.v8**
Calibration procedure for dipole validation kits above 700 MHz

Calibration date: **July 20, 2012**

This calibration certificate documents the traceability to national standards, which realize the physical units of measurements (SI).
The measurements and the uncertainties with confidence probability are given on the following pages and are part of the certificate.

All calibrations have been conducted in the closed laboratory facility: environment temperature (22 ± 3)°C and humidity < 70%.

Calibration Equipment used (M&TE critical for calibration)

| Primary Standards | ID # | Cal Date (Certificate No.) | Scheduled Calibration |
|-----------------------------|--------------------|-----------------------------------|------------------------|
| Power meter EPM-442A | QE37480704 | 05-Oct-11 (No. 217-01451) | Oct-12 |
| Power sensor HP 8481A | US37292783 | 05-Oct-11 (No. 217-01451) | Oct-12 |
| Reference 20 dB Attenuator | SN: 5058 (20k) | 27-Mar-12 (No. 217-01530) | Apr-13 |
| Type-N mismatch combination | SN: 5047.2 / 06327 | 27-Mar-12 (No. 217-01533) | Apr-13 |
| Reference Probe ES3DV3 | SN: 3205 | 30-Dec-11 (No. ES3-3205_Dec11) | Dec-12 |
| DAE4 | SN: 601 | 27-Jun-12 (No. DAE4-601_Jun12) | Jun-13 |
| Secondary Standards | ID # | Check Date (In house) | Scheduled Check |
| Power sensor HP 8481A | MY41092317 | 18-Oct-02 (in house check Oct-11) | In house check: Oct-13 |
| RF generator R&S SMT-06 | 100005 | 04-Aug-09 (in house check Oct-11) | In house check: Oct-13 |
| Network Analyzer HP 8753E | US37390585 S4206 | 18-Oct-01 (in house check Oct-11) | In house check: Oct-12 |

| | | | |
|----------------|-----------------------|-----------------------------------|---------------|
| Calibrated by: | Name Dimitri Iliev | Function Laboratory Technician | Signature |
| Approved by: | Name Katja Pokovic | Function Technical Manager | Signature |

Issued: July 20, 2012

This calibration certificate shall not be reproduced except in full without written approval of the laboratory.

Calibration Laboratory of
Schmid & Partner
Engineering AG
Zeughausstrasse 43, 8004 Zurich, Switzerland



S Schweizerischer Kalibrierdienst
C Service suisse d'étalonnage
S Servizio svizzero di taratura
S Swiss Calibration Service

Accredited by the Swiss Accreditation Service (SAS)

The Swiss Accreditation Service is one of the signatories to the EA
Multilateral Agreement for the recognition of calibration certificates

Accreditation No.: SCS 108

Glossary:

TSL tissue simulating liquid
ConvF sensitivity in TSL / NORM x,y,z
N/A not applicable or not measured

Calibration is Performed According to the Following Standards:

- IEEE Std 1528-2003, "IEEE Recommended Practice for Determining the Peak Spatial-Averaged Specific Absorption Rate (SAR) in the Human Head from Wireless Communications Devices: Measurement Techniques", December 2003
- IEC 62209-1, "Procedure to measure the Specific Absorption Rate (SAR) for hand-held devices used in close proximity to the ear (frequency range of 300 MHz to 3 GHz)", February 2005
- Federal Communications Commission Office of Engineering & Technology (FCC OET), "Evaluating Compliance with FCC Guidelines for Human Exposure to Radiofrequency Electromagnetic Fields; Additional Information for Evaluating Compliance of Mobile and Portable Devices with FCC Limits for Human Exposure to Radiofrequency Emissions", Supplement C (Edition 01-01) to Bulletin 65

Additional Documentation:

- DASY4/5 System Handbook

Methods Applied and Interpretation of Parameters:

- Measurement Conditions:** Further details are available from the Validation Report at the end of the certificate. All figures stated in the certificate are valid at the frequency indicated.
- Antenna Parameters with TSL:** The dipole is mounted with the spacer to position its feed point exactly below the center marking of the flat phantom section, with the arms oriented parallel to the body axis.
- Feed Point Impedance and Return Loss:** These parameters are measured with the dipole positioned under the liquid filled phantom. The impedance stated is transformed from the measurement at the SMA connector to the feed point. The Return Loss ensures low reflected power. No uncertainty required.
- Electrical Delay:** One-way delay between the SMA connector and the antenna feed point. No uncertainty required.
- SAR measured:** SAR measured at the stated antenna input power.
- SAR normalized:** SAR as measured, normalized to an input power of 1 W at the antenna connector.
- SAR for nominal TSL parameters:** The measured TSL parameters are used to calculate the nominal SAR result.

The reported uncertainty of measurement is stated as the standard uncertainty of measurement multiplied by the coverage factor $k=2$, which for a normal distribution corresponds to a coverage probability of approximately 95%.

Measurement Conditions

DASY system configuration, as far as not given on page 1.

| | | |
|------------------------------|------------------------|-------------|
| DASY Version | DASY5 | V52.8.1 |
| Extrapolation | Advanced Extrapolation | |
| Phantom | Modular Flat Phantom | |
| Distance Dipole Center - TSL | 10 mm | with Spacer |
| Zoom Scan Resolution | dx, dy, dz = 5 mm | |
| Frequency | 1900 MHz ± 1 MHz | |

Head TSL parameters

The following parameters and calculations were applied.

| | Temperature | Permittivity | Conductivity |
|---|-----------------|--------------|------------------|
| Nominal Head TSL parameters | 22.0 °C | 40.0 | 1.40 mho/m |
| Measured Head TSL parameters | (22.0 ± 0.2) °C | 39.9 ± 6 % | 1.38 mho/m ± 6 % |
| Head TSL temperature change during test | < 0.5 °C | --- | --- |

SAR result with Head TSL

| SAR averaged over 1 cm ³ (1 g) of Head TSL | Condition | |
|---|--------------------|----------------------------|
| SAR measured | 250 mW input power | 9.68 mW / g |
| SAR for nominal Head TSL parameters | normalized to 1W | 39.0 mW / g ± 17.0 % (k=2) |

| SAR averaged over 10 cm ³ (10 g) of Head TSL | condition | |
|---|--------------------|----------------------------|
| SAR measured | 250 mW input power | 5.11 mW / g |
| SAR for nominal Head TSL parameters | normalized to 1W | 20.5 mW / g ± 16.5 % (k=2) |

Body TSL parameters

The following parameters and calculations were applied.

| | Temperature | Permittivity | Conductivity |
|---|-----------------|--------------|------------------|
| Nominal Body TSL parameters | 22.0 °C | 53.3 | 1.52 mho/m |
| Measured Body TSL parameters | (22.0 ± 0.2) °C | 52.6 ± 6 % | 1.52 mho/m ± 6 % |
| Body TSL temperature change during test | < 0.5 °C | --- | --- |

SAR result with Body TSL

| SAR averaged over 1 cm ³ (1 g) of Body TSL | Condition | |
|---|--------------------|----------------------------|
| SAR measured | 250 mW input power | 10.0 mW / g |
| SAR for nominal Body TSL parameters | normalized to 1W | 39.9 mW / g ± 17.0 % (k=2) |

| SAR averaged over 10 cm ³ (10 g) of Body TSL | condition | |
|---|--------------------|----------------------------|
| SAR measured | 250 mW input power | 5.30 mW / g |
| SAR for nominal Body TSL parameters | normalized to 1W | 21.2 mW / g ± 16.5 % (k=2) |

Appendix

Antenna Parameters with Head TSL

| | |
|--------------------------------------|-----------------|
| Impedance, transformed to feed point | 50.0 Ω + 3.1 jΩ |
| Return Loss | - 30.1 dB |

Antenna Parameters with Body TSL

| | |
|--------------------------------------|-----------------|
| Impedance, transformed to feed point | 46.2 Ω + 3.7 jΩ |
| Return Loss | - 25.2 dB |

General Antenna Parameters and Design

| | |
|----------------------------------|----------|
| Electrical Delay (one direction) | 1.194 ns |
|----------------------------------|----------|

After long term use with 100W radiated power, only a slight warming of the dipole near the feedpoint can be measured.

The dipole is made of standard semirigid coaxial cable. The center conductor of the feeding line is directly connected to the second arm of the dipole. The antenna is therefore short-circuited for DC-signals. On some of the dipoles, small end caps are added to the dipole arms in order to improve matching when loaded according to the position as explained in the "Measurement Conditions" paragraph. The SAR data are not affected by this change. The overall dipole length is still according to the Standard.

No excessive force must be applied to the dipole arms, because they might bend or the soldered connections near the feedpoint may be damaged.

Additional EUT Data

| | |
|-----------------|----------------|
| Manufactured by | SPEAG |
| Manufactured on | March 17, 2003 |

DASY5 Validation Report for Head TSL

Date: 20.07.2012

Test Laboratory: SPEAG, Zurich, Switzerland

DUT: Dipole 1900 MHz; Type: D1900V2; Serial: D1900V2 - SN: 5d032

Communication System: CW; Frequency: 1900 MHz

Medium parameters used: $f = 1900$ MHz; $\sigma = 1.38$ mho/m; $\epsilon_r = 39.9$; $\rho = 1000$ kg/m³

Phantom section: Flat Section

Measurement Standard: DASY5 (IEEE/IEC/ANSI C63.19-2007)

DASY52 Configuration:

- Probe: ES3DV3 - SN3205; ConvF(5.01, 5.01, 5.01); Calibrated: 30.12.2011;
- Sensor-Surface: 3mm (Mechanical Surface Detection)
- Electronics: DAE4 Sn601; Calibrated: 27.06.2012
- Phantom: Flat Phantom 5.0 (front); Type: QD000P50AA; Serial: 1001
- DASY52 52.8.1(838); SEMCAD X 14.6.5(6469)

Dipole Calibration for Head Tissue/Pin=250 mW, d=10mm/Zoom Scan (7x7x7)/Cube 0:

Measurement grid: dx=5mm, dy=5mm, dz=5mm

Reference Value = 96.864 V/m; Power Drift = 0.03 dB

Peak SAR (extrapolated) = 17.209 mW/g

SAR(1 g) = 9.68 mW/g; SAR(10 g) = 5.11 mW/g

Maximum value of SAR (measured) = 12.1 mW/g

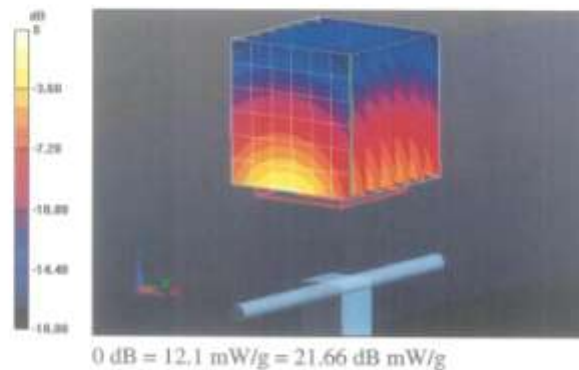

Impedance Measurement Plot for Head TSL

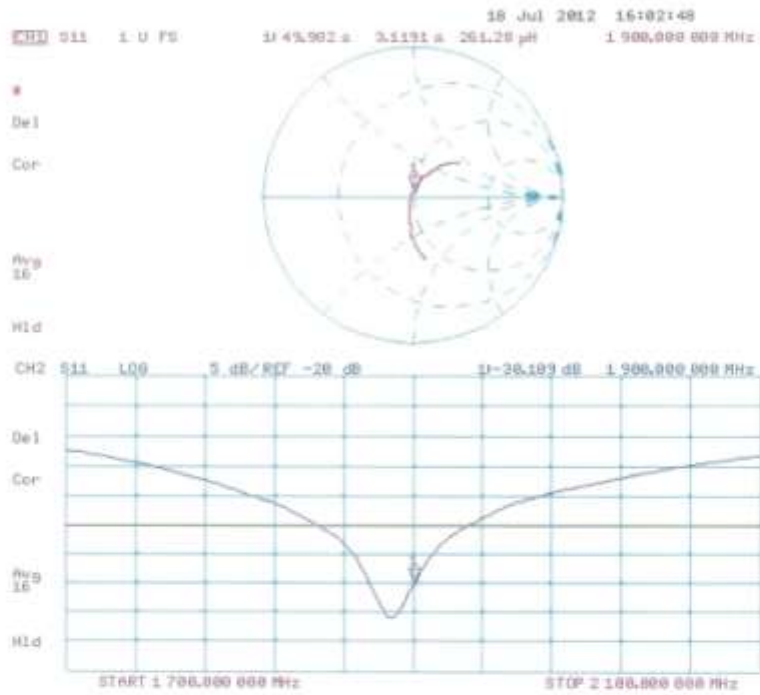

DASY5 Validation Report for Body TSL

Date: 20.07.2012

Test Laboratory: SPEAG, Zurich, Switzerland

DUT: Dipole 1900 MHz; Type: D1900V2; Serial: D1900V2 - SN: 5d032

Communication System: CW; Frequency: 1900 MHz

Medium parameters used: $f = 1900$ MHz; $\sigma = 1.52$ mho/m; $\epsilon_r = 52.6$; $\rho = 1000$ kg/m³

Phantom section: Flat Section

Measurement Standard: DASY5 (IEEE/IEC/ANSI C63.19-2007)

DASY52 Configuration:

- Probe: ES3DV3 - SN3205; ConvF(4.62, 4.62, 4.62); Calibrated: 30.12.2011;
- Sensor-Surface: 3mm (Mechanical Surface Detection)
- Electronics: DAE4 Sn601; Calibrated: 27.06.2012
- Phantom: Flat Phantom 5.0 (back); Type: QD000P50AA; Serial: 1002
- DASY52 52.8.1(838); SEMCAD X 14.6.5(6469)

Dipole Calibration for Body Tissue/Pin=250 mW, d=10mm/Zoom Scan (7x7x7)/Cube 0:Measurement grid: $dx=5$ mm, $dy=5$ mm, $dz=5$ mm

Reference Value = 95.470 V/m; Power Drift = -0.00 dB

Peak SAR (extrapolated) = 17.332 mW/g

SAR(1 g) = 10 mW/g; SAR(10 g) = 5.3 mW/g

Maximum value of SAR (measured) = 12.6 mW/g

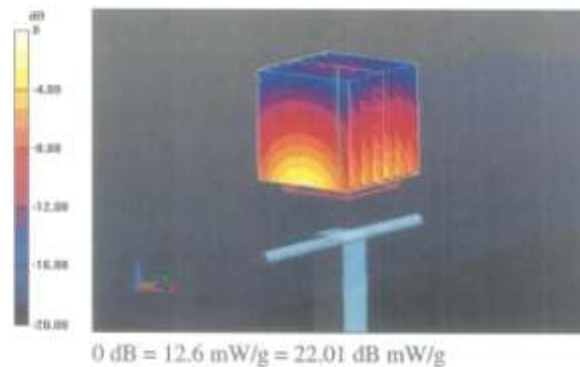

Impedance Measurement Plot for Body TSL

